

AD-A268 182

2

SMC-TR-93-39



AEROSPACE REPORT NO.
TR-93(3530)-1

S DTIC
ELECTE
AUG 16 1993
C **D**

Contamination Detection and Filtering
in a Gaseous Stream

Prepared by

F. BABAN, R. L. VARWIG, D. A. DURRAN, and J. M. HERBELIN
Mechanics and Materials Technology Center
Technology Operations

20 January 1993

Prepared for

SPACE AND MISSILE SYSTEMS CENTER
AIR FORCE MATERIEL COMMAND
2430 E. El Segundo Boulevard
Los Angeles Air Force Base, CA 90245

Programs Group

THE AEROSPACE CORPORATION
El Segundo, California



93 8 11 016

APPROVED FOR PUBLIC RELEASE
DISTRIBUTION UNLIMITED

93-18751



This report was submitted by The Aerospace Corporation, El Segundo, CA 90245-4691, under Contract No. F04701-88-C-0089 with the Space and Missile Systems Center, P. O. Box 92960, Los Angeles, CA 90009-2960. It was reviewed and approved for The Aerospace Corporation by R. W. Fillers, Principal Director, Mechanics and Materials Technology Center. Lt. Col. Benjamin G. Higbie, Jr. was the project officer.

This report has been reviewed by the Public Affairs Office (PAS) and is releasable to the National Technical Information Service (NTIS). At NTIS, it will be available to the general public, including foreign nationals.

This technical report has been reviewed and is approved for publication. Publication of this report does not constitute Air Force approval of the report's findings or conclusions. It is published only for the exchange and stimulation of ideas.

BENJAMIN G. HIGBIE, JR., LT COL, USAF
Director, Systems Engineering
Titan System Program Office

WM KYLE SNEEDON, CAPT, USAF
Industrial & Int'l Division
Plans & Programs Directorate

REPORT DOCUMENTATION PAGEForm Approved
OMB No. 0704-0188

Public reporting burden for this collection of information is estimated to average 1 hour per response, including the time for reviewing instructions, searching existing data sources, gathering and maintaining the data needed, and completing and reviewing the collection of information. Send comments regarding this burden estimate or any other aspect of this collection of information, including suggestions for reducing this burden to Washington Headquarters Services, Directorate for Information Operations and Reports, 1215 Jefferson Davis Highway, Suite 1204, Arlington, VA 22202-4302, and to the Office of Management and Budget, Paperwork Reduction Project (0704-0188), Washington, DC 20503.

1. AGENCY USE ONLY (Leave blank)		2. REPORT DATE 1993 January 20	3. REPORT TYPE AND DATES COVERED	
4. TITLE AND SUBTITLE Contamination Detection and Filtering in a Gaseous Stream			5. FUNDING NUMBERS F04701-88-C-0089	
6. AUTHOR(S) Baban, Farzad; Varwig, Robert L.; Durran, Donald A.; and Herbelin, John M.			8. PERFORMING ORGANIZATION REPORT NUMBER TR-93(3530)-1	
7. PERFORMING ORGANIZATION NAME(S) AND ADDRESS(ES) The Aerospace Corporation Technology Operations El Segundo, CA 90245-4691			10. SPONSORING/MONITORING AGENCY REPORT NUMBER SMC-TR-93-39	
9. SPONSORING/MONITORING AGENCY NAME(S) AND ADDRESS(ES) Space and Missile Systems Center Los Angeles Air Force Base Los Angeles, CA 90009-2960			11. SUPPLEMENTARY NOTES	
12a. DISTRIBUTION/AVAILABILITY STATEMENT Approved for public release; distribution unlimited			12b. DISTRIBUTION CODE	
13. ABSTRACT (Maximum 200 words) <p>At the request of the Chemical Systems Directorate of Space Launch Operations, an experimental investigation was undertaken to evaluate the candidate filter system for removing oil aerosols from pressurized gaseous nitrogen lines. The experiment was geared to simulate the conditions encountered at the Titan IV launch site where gaseous nitrogen supply lines, used to pressurize the propellant tanks and purge electronic components, were found contaminated with oil.</p> <p>A test apparatus was designed and promptly assembled in which a clean GN₂ stream flowed through two filters in series (a 200-80-DX Balston filter followed by a 200-80-BX filter). Provisions were made to have the capabilities of flowing GN₂ at a wide range of flow rates and pressures. An oil-injecting mechanism was designed, fabricated, and tested to provide oil aerosols at a wide range of flow rates. In particular, it was important to inject oil at low flow rates (e.g., less than 1 g/min.). Thus, various oil contamination levels were conveniently achieved by controlling the ratio of oil to GN₂ flow rate. Several diagnostic approaches such as gravimetric techniques, witness window verifications, and wipe inspections were employed to assess the adequacy of the filters in extracting the oil from the GN₂ stream. Due to a launch pad safety requirement, tolerable oil contamination</p>				
14. SUBJECT TERMS Filtering, Contamination, Oil detection			15. NUMBER OF PAGES 25	
			16. PRICE CODE	
17. SECURITY CLASSIFICATION OF REPORT UNCLASSIFIED	18. SECURITY CLASSIFICATION OF THIS PAGE UNCLASSIFIED	19. SECURITY CLASSIFICATION OF ABSTRACT UNCLASSIFIED	20. LIMITATION OF ABSTRACT	

levels were quite stringent (i.e., 5 ppm by weight). Thus, in addition to the above detection techniques, two laser diagnostics approaches were employed to enable us to detect oil contamination at 5 ppm level or less. One method employed a laser sheet to illuminate the flow cross-section. Mie scattering from the oil droplets was detected by a photomultiplier tube focused on the illuminated cross-section. The second approach involved a laser cavity attenuation method in which the loss in cavity was attenuated by the oil aerosol passing through the cavity or coating the mirrors. We demonstrate that the latter technique was so sensitive that oil contamination levels as low as a few ppm could be detected. This, however, can be further optimized, and the technique can be made far more sensitive (orders of magnitude) in detecting any particulate in the GN₂ stream.

The filters were found very effective in extracting the oil droplets from the gaseous nitrogen stream. In fact, in a series of runs where the worst-case scenarios were tested, the combination of the two filters proved to be quite adequate, i.e., no oil was detected downstream of the second filter. The worst-case scenarios were simulated by subjecting the filters to adverse and very harsh conditions such as subjecting the DX-filter to impingement of a slug of oil, saturating the DX-filter with oil, and impinging a slug of oil onto a saturated DX-filter.

The entire program from the initial inception of the experiment to data collection and reduction was accomplished successfully in less than 4 weeks on a tight schedule demanded by the Chemical Systems Directorate of Space Launch Operations. Relevant conclusions and appropriate recommendations were conveyed to the Titan program office in charge. In particular, the suggestion of placing a witness window immediately downstream of the BX-filter has been well received and may be employed at the launch site. Also, the use of a transparent extension to the filter-canister drain has been recommended, which may be incorporated in the design. This will allow early detection of a saturated filter that needs to be replaced.

CONTENTS

1.	INTRODUCTION.....	3
2.	OBJECTIVE.....	5
3.	APPARATUS.....	7
	3.1 OIL INJECTOR.....	8
4.	DIAGNOSTICS.....	11
	4.1 MIE SCATTERING TECHNIQUE.....	11
	4.2 CAVITY ATTENUATION TECHNIQUE.....	13
5.	RESULTS AND DISCUSSION.....	17
	RUN 1.....	17
	RUN 2.....	19
	RUN 3.....	20
	RUNS 4-8.....	20
	RUNS 9-14.....	22
	RUNS 15-18.....	24
6.	CONCLUSIONS AND RECOMMENDATIONS.....	25

DTIC QUALITY INSPECTED 3

Accession For	
NTIS CRA&I	<input checked="" type="checkbox"/>
DTIC TAB	<input type="checkbox"/>
Unannounced Justification	<input type="checkbox"/>
By _____	
Distribution /	
Availability Codes	
Dist	Avail and/or Special
A-1	

FIGURES

1. Schematic of a coalescing filter.....	4
2. Initial experimental setup showing three viewports before, between, and after the filters.....	7
3. Schematic of oil injector.....	9
4. Optical detector for observing Mie scattered light from oil droplets in gas flow.....	12
5. Photograph of apparatus showing optical system and flow tube	13
6. Improved cavity system for employment of cavity attenuation technique.....	15
7. Schematic of test apparatus with three viewports placed, before, between, and after the filters (Run 1).....	17
8. Schematic of test apparatus with two viewports placed between and after the filters (Runs 2, 3, and 4)	19
9. Schematic of test apparatus with one viewport placed downstream of the second filter (Runs 5, 15, and 16)	21
10. Schematic of test apparatus with U-tube for oil impingement tests (Runs 6, 7, 8, 17, and 18).....	22
11. Schematic of test apparatus with no filters to demonstrate sensitivity of laser diagnostic technique (Runs 9-14).....	23

TABLE

1. Reduced Data for All Runs	18
------------------------------------	----

1. INTRODUCTION

In June 1991, oil was detected in the nitrogen supply lines at space launch complex 4-West (SLC-4W) at Vandenberg Air Force Base. These gaseous nitrogen (GN₂) lines are used to pressurize the propellant tanks and purge electronics for Titan IV launch vehicles. The presence of oil in the line and its effect on materials and instrumentation, as well as its solubility in the propellants, could adversely impact the launch schedule and was of great concern to the Titan Program Office. Several investigative teams were assembled at Aerospace to identify the contaminants, their levels, and sources in the GN₂ supply lines. However, in order not to postpone the next scheduled flight, a short-term fix was proposed. The proposed fix was a filter system to extract the contaminating oil from the nitrogen stream. The candidate filter system consisted of a 200-80-DX Balston filter followed by a 200-80-BX type, both of which were housed in Balston 27/80 filter housings. Both filters were graded-porosity coalescing filters consisting of a glass microfiber coalescing element, a plastic retainer, and a glass-fiber drain layer. The glass fibers are vacuum formed into interlocking contact and bound together with an epoxy coating. The epoxy aids oil agglomeration and resists wetting from water vapor, which would weaken the filter tube.

In a coalescing filter, the contaminated gaseous stream passes through the graded porosity element from inside out (Figure 1). Solid particles are captured and held by direct impact, interception, or diffusion, depending on their size. Oil aerosols are also captured but are forced through the filter matrix by the gaseous stream. Filter density lessens toward the outer surface, forcing the captured aerosols to agglomerate into larger and larger droplets. When the droplets emerge on the outside of the element, they are enlarged and conducted to drain sites by the drain layer. Gravity draws the collected oil to the bottom of the filter tube where it drips into the sump and is drained away. The DX-grade filter was reported by the manufacturer to be 99.97% efficient for removing aerosols in the 0.3–0.6 μm range whereas the BX-grade filter is reportedly 99.998% efficient since the pores in the interior layer of the filter element are smaller.

With the above information in mind, a series of tests was needed to confirm the validity of the manufacturer's claim and qualify the proposed filter system. Thus, a full-scale laboratory experiment was proposed to evaluate the effectiveness of the filter system for removing oil aerosols from pressurized GN₂ lines. The specific objective of this experimental program is stated below. A brief description of the apparatus and employed diagnostic techniques is presented along with the results and discussion. The highlights of the results are summarized in the Conclusion and Recommendations section. Recommendations are made leading to two system design modifications.

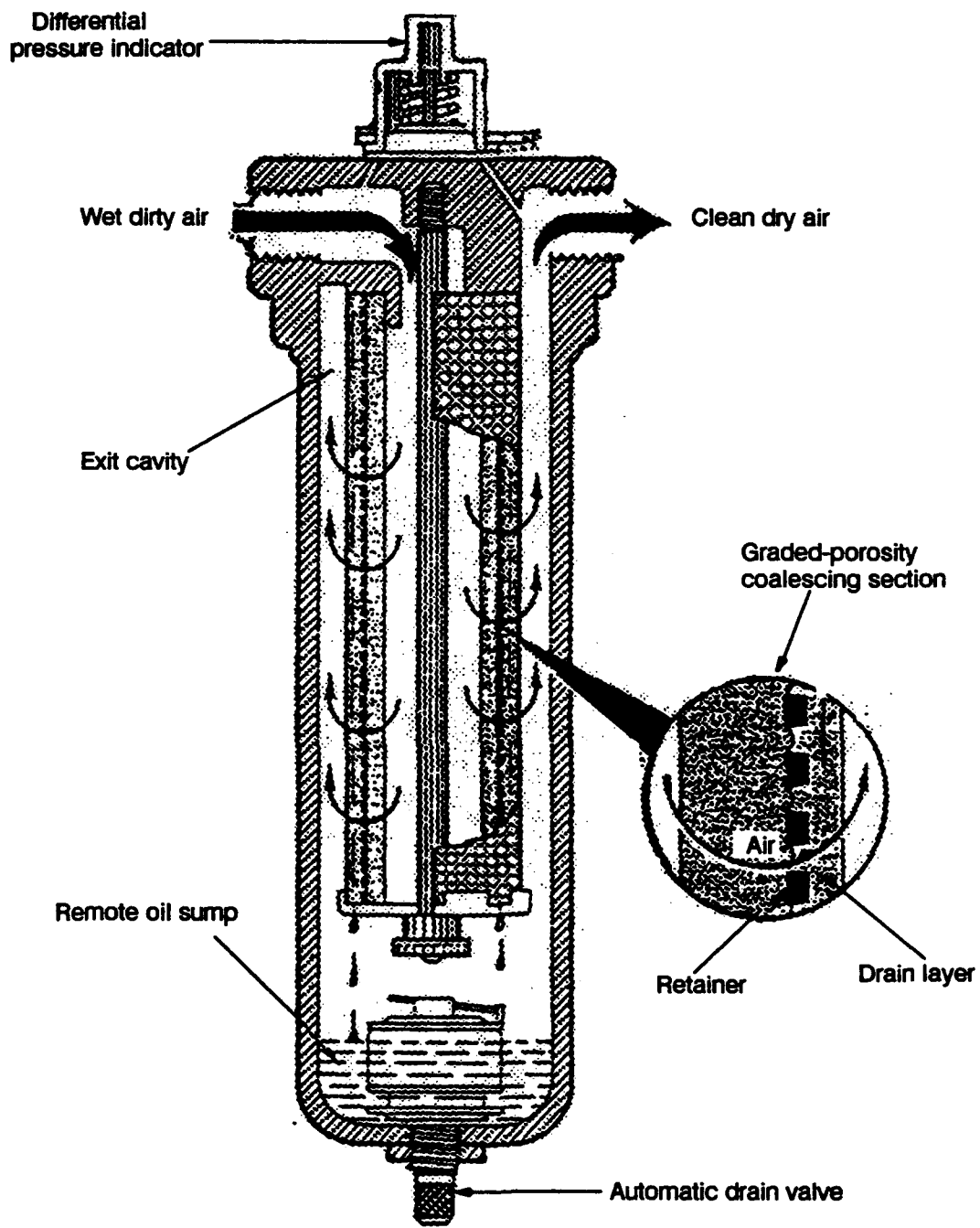

Figure 1. Schematic of a coalescing filter.

2. OBJECTIVE

The objective is to perform a series of laboratory experiments to evaluate the effectiveness of the Balston filter system in removing oil from a nitrogen stream subjected to the following conditions:

1. Various GN₂ flow rates
2. Different contamination levels, in particular, low oil loading (i.e., 5 ppm by weight)
3. Filters subjected to impingement of a slug of oil rather than oil aerosols
4. Upstream filter (DX-grade) saturated with oil
5. Saturated DX-grade filter subjected to impingement of a slug of oil

For the conditions described above, a reliable diagnostic technique needed to be devised capable of detecting oil contamination levels as low as 5 ppm or lower.

3. APPARATUS

A full-scale apparatus simulating the actual conditions encountered in Vandenberg AFB was promptly assembled. To establish unambiguously the contamination level in the GN_2 stream, the in-house nitrogen supply was not used. Instead, 18 A-size nitrogen bottles, rated ultrapure and initially filled to 2600 psig, were connected to a manifold to supply the flow of nitrogen. A pressure regulator was connected to the manifold downstream of which a pressure relief valve was placed for safety reasons. For flow rate measurement purposes, an orifice made of aluminum was placed downstream of the relief valve to serve as sonic throat. The choke condition was verified by measuring the pressure upstream and downstream of the sonic throat. Copper tubing (1.0 in. I.D.) was used to join the orifice plate to a DX-grade Balston filter downstream of which a BX-grade filter was situated. A pressure relief valve, immediately followed by a throttling valve, was then placed in line to control and maintain the desired pressure throughout the nitrogen line and around the filters. The line was then fed to a muffler exhausted to outside the building (Figure 2).

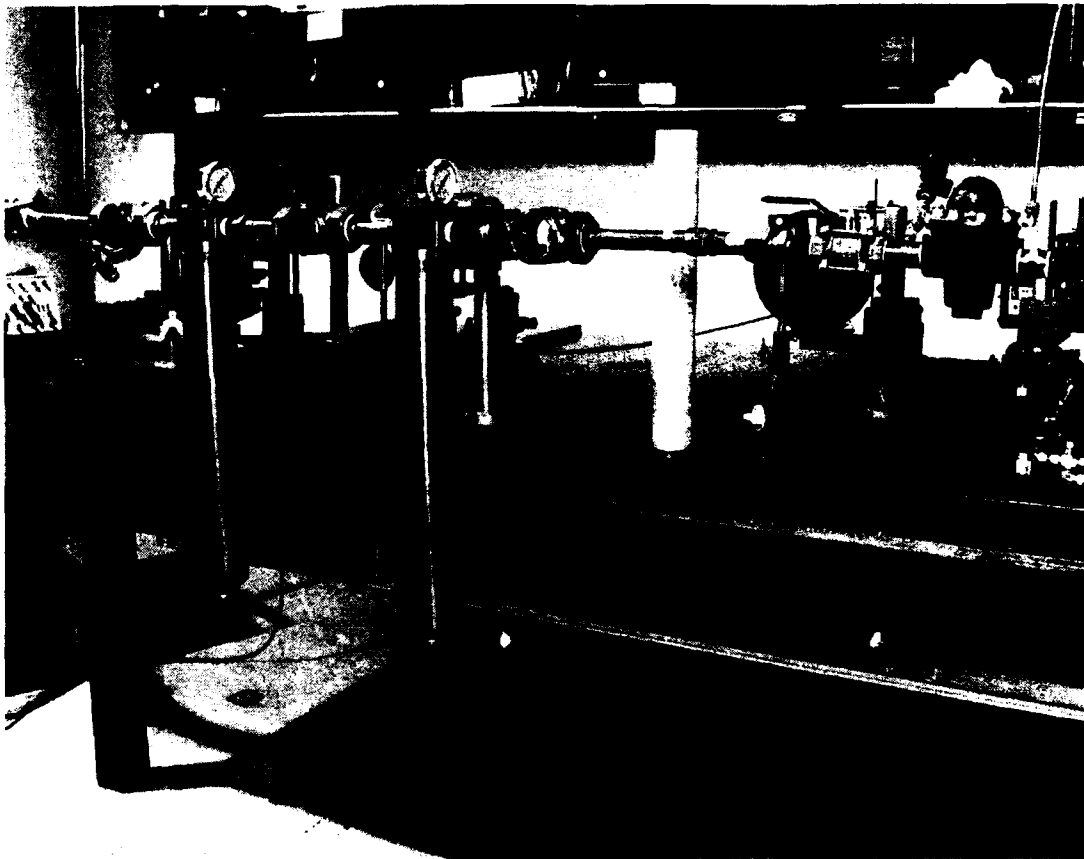

Figure 2. Initial experimental setup showing three viewports before, between, and after the filters.

To have visual access to inside the GN₂ lines, three view ports were placed in line before, between, and after the filters. The view ports were rated for 225 psi pressure and were made of brass with two side-glass windows, 2 in. in diameter. Later, a different set of view ports were designed, fabricated, and installed in which the windows were far removed from the nitrogen stream. This was done to alleviate the problem of oil splashing on the windows and thus inhibiting visual access.

To contaminate the gaseous nitrogen stream with oil to a desired contamination level, an oil-injecting mechanism was designed and fabricated. The injector was designed particularly for a low flow rate of oil (e.g., less than 1 g/min). This was done to enable us to assess the efficiency of the filter system at low contamination levels. Shell Turbo 220 oil was used as a surrogate oil to be injected into the nitrogen stream. The details of the oil injector design will be discussed next.

3.1 Oil Injector

The injector consisted of two separate pieces: a mechanical pump and an injector nozzle. The two were connected by a flexible 1/16 in. stainless-steel tube.

The pump consisted of a screw-driven piston used to positively displace the oil. An adjustable Minarik electric motor geared for 0–20 rpm was attached to a 1/4 in. diameter, 20 thread/inch rod, which drew a cylindrical oil reservoir toward the motor. The rod contacted a 5/8 in. diameter Teflon piston fitted with a 1/16 in. Viton O-ring. Oil displacement resulted by drawing the oil reservoir over the piston. A 1/4 in. ball valve connected the reservoir to the flexible tube that adjoins the injector nozzle.

The reservoir was refilled by closing the 1/4 in. ball valve and withdrawing the threaded rod. A one-pint refill oil reservoir was accessed through a 1/4 in. needle valve. Pressurization of the reservoir resulted in a flow of oil that forced the piston back to the end of the cylindrical reservoir, restoring the required oil level. The needle valve was then closed (Figure 3).

The injection system was designed with two specific objectives in mind: metering the nitrogen flow and atomizing the oil. The oil delivery necked down from the flexible tube into a hypodermic tube of 0.018 in. I.D. The resulting flow of oil was injected through a sonic orifice. The oil/nitrogen flow expanded through a normal shock to enhance atomization before impacting a fine stainless-steel mesh that spread the oil about the cross-sectional area of the 1 in. diameter pipe. Two orifice plates were used to meter the flow for a static back pressure of 300 psig. A choked flow rate of 200 scfm passed through a 0.224 in. diameter nozzle, while a 0.079 in. diameter nozzle restricted the flow to 25 scfm.

A calibration of the motor speed setting vs oil delivery rate was performed to accurately meter oil flow rates between 0.1 g/s to 3.5 g/s.

INJECTOR NOZZLE

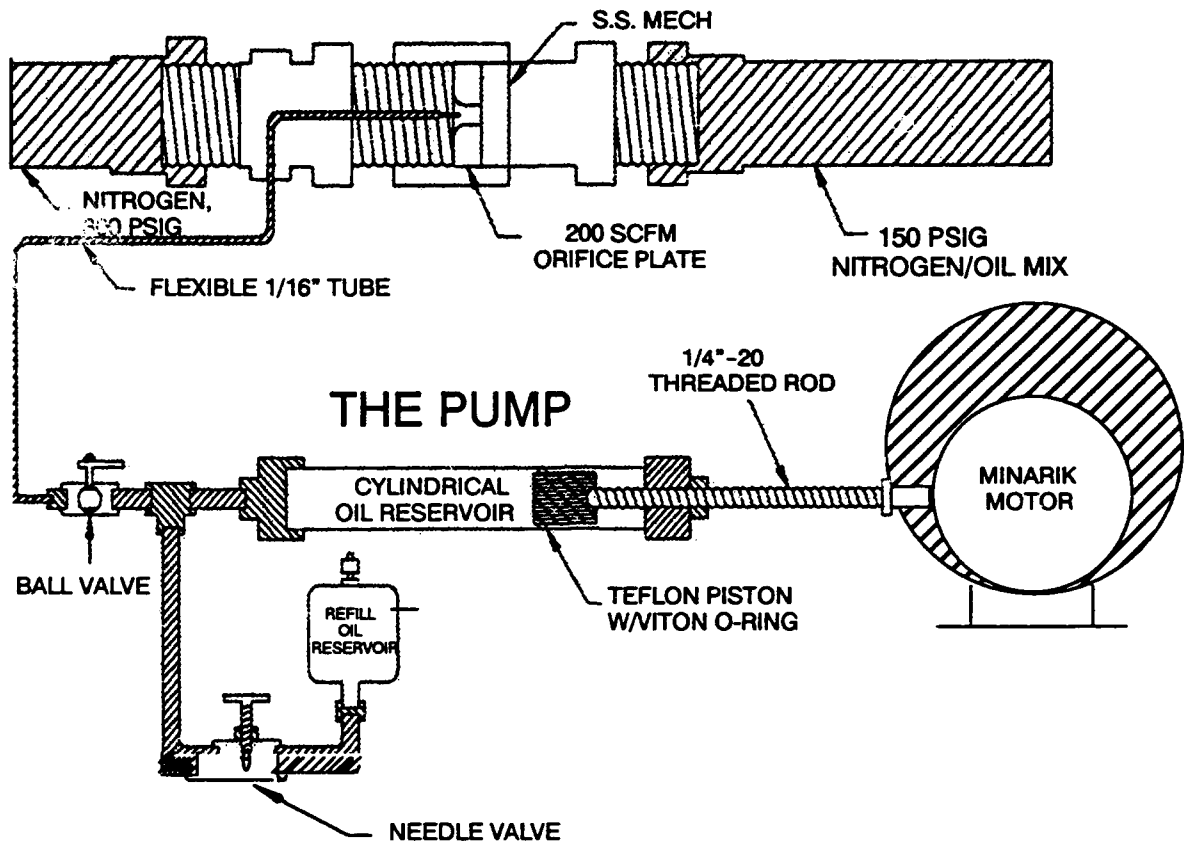

Figure 3. Schematic of oil injector.

4. DIAGNOSTICS

Several diagnostic techniques were used to evaluate the effectiveness of the filter system. Wipe inspection and witness window verification methods were used to qualitatively assess the adequacy of the filters in removing the oil droplets or oil slugs from the nitrogen stream. Gravimetric analysis, on the other hand, proved to be very reliable and a fairly reproducible quantitative measurement technique. The filter elements were accurately weighed and then inserted into the filter canisters prior to each run. They were re-weighed after performing the experiment, and the weight increase was noted and recorded. An electronic scale capable of measuring down to 0.01 gram was used for this purpose. The scale was recalibrated for the appropriate weight range each time a filter was weighed.

In addition to the above methods, two laser diagnostic techniques were utilized for detecting oil contamination at very low levels (e.g., 5 ppm). One of the techniques employed a laser sheet to illuminate the flow cross-section. Mie scattering from the oil droplets was detected by a photomultiplier tube focused on the illuminated cross-section. The second approach was a laser cavity attenuation method in which the loss in cavity was attenuated by the oil aerosol passing through the cavity or coating the mirrors. Details of both techniques are described herein.

4.1 Mie Scattering Technique

An optical detector was employed to detect and measure the oil aerosols escaping the filtering system. The system consisted of an expanded laser beam to provide a light sheet across an oil aerosol containing nitrogen gas flow, and a photomultiplier light detector. A quantitative measure of the oil droplet density was made using the scattered light from the illuminated cross-section as the droplets passed through it. Flow cross-section was illuminated by creating a laser sheet. Forward scattering was employed since Mie scattering from the droplets is most intense in the forward direction.

The optical system employed is shown in Figure 4. An argon ion laser beam was passed through two cylindrical lenses, the first of which expanded the beam into a narrow vertical strip of light of indeterminate height, and the second of which converged it to a finite collimated strip. When light-scattering particles in the flow passed through the vertical light strip, it looked much like an extended light source when viewed at an angle to the flow and the beam.

The light strip was projected across the flow path at several incident angles with respect to the flow direction. Forward-scattered light was observed from the other side of the test section at about the same angles with respect to the flow direction. It was observed that light scattered from the four surfaces of the windows on both sides of the flow facility was so intense as to interfere and perturb the signal (i.e., light scattered by the oil droplets illuminated in the flow). Hence, the light scattered by the windows was prevented from entering the photomultiplier detector. This was accomplished by focusing the scattered beam on a slit of such width as to eliminate the window-scattered light from entering the detector.

A gallium arsenide photomultiplier just aft of the slit served to sense the scattered beam intensity. The laser beam was chopped so that the signal from the photomultiplier could be amplified by use of a lock-in amplifier frequency-locked to the laser beam chopping rate. By this means, the effect of room light and stray light from unknown sources was greatly reduced.

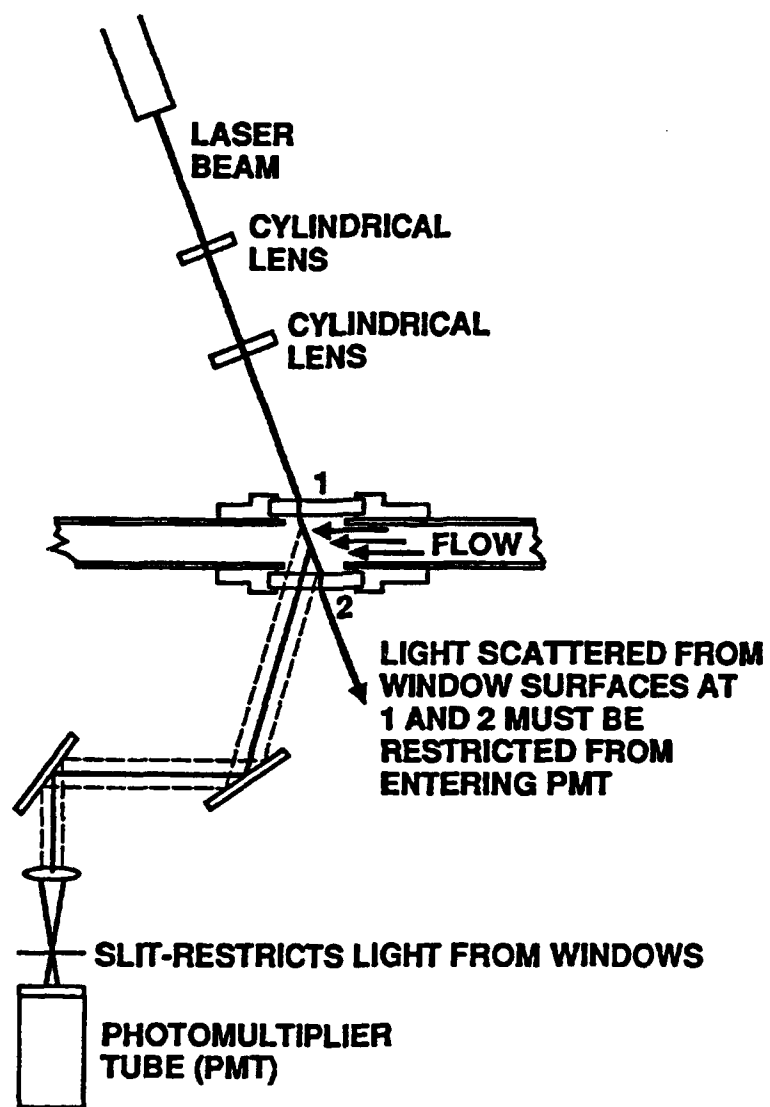

Figure 4. Optical detector for observing Mie scattered light from oil droplets in gas flow.

Photographs of the apparatus, including the input optical system, lenses, and detector as well as a view of the optical table, argon ion laser, and portions of the flow duct are shown in Figure 5.

The system was calibrated by observing the scattered light when a known amount of oil was injected into the flow just upstream of the detector section.

4.2 Cavity Attenuation Technique

The second optical diagnostic technique, employed for measuring oil droplet concentration in the GN_2 stream, is based on Cavity Attenuation Phase Shift (CAPS) method. In the CAPS method, the reflectance of mirrors making up the optical cavity is determined by observing the phase shift of a modulated CW laser beam as it passes through the cavity. The phase shift is related to the number of round trips a photon makes before its energy is reduced to $(1/e)$ of its initial value. The dissipation of photon energy in the cavity resonator is by absorption, scattering, or transmission at the cavity mirror surface or in the medium in between the mirrors. Thus, the CAPS method can be used to measure the scattering of the beam by a solid, liquid, or gaseous medium between the mirrors if the mirror reflectances are known.



Figure 5. Photograph of apparatus showing optical system and flow tube.

^{*}J. M. Herbelin, et al., *Applied Optics*, Vol. 19, No. 1, January 1980, pp. 144-147.

The application of the CAPS method to determining the density of scattering centers introduced by oil droplets in a gaseous medium seemed appropriate. Further, this method for determining beam attenuation by scattering can also be applied to measure the effectiveness of filters designed to remove oil droplets. One needs only to observe the attenuation of the beam in the cavity when a flow is introduced into the cavity before and after filtering.

The sensitivity of the attenuation of the beam to detecting changes in the cavity was determined by measuring the transmittance of the cavity relative to that of a single mirror of the cavity. Mirrors used to establish the cavity were 99.99% reflective. Therefore, when a single mirror was in place, only 0.01% of the laser beam was transmitted. When both mirrors were in place and aligned, establishing the resonator cavity, transmission was reduced by a factor of 17 or 6×10^{-6} times the original beam intensity.

In this experiment, the optical cavity was installed at the exhaust end of a 1-in. diameter gaseous nitrogen line. The flow exhausted across the cavity so that any oil droplets in the flow attenuated the beam due to scattering of light from the beam. The CW laser beam was provided by an argon ion laser, the power of which is variable from 20 to 150 mW. Beam intensity was measured by a P-128 photomultiplier tube, the signal from which was amplified by a Princeton Applied Research Model 124A lock-in amplifier. A chopper was installed in the laser beam, and the chopping frequency was applied to the reference channel of the amplifier to provide the lock-in frequency. The output signal from the amplifier was proportional to the beam intensity striking the photomultiplier tube.

In the test, the flow was first established in the 1-in.-diameter pipe. Since the specifications of the filter evaluation require the flow to be at a pressure of 150 psig, establishing the flow took a while to adjust both the upstream and the downstream valves. After the flow was established, oil was injected into the flow by a solid piston system. The response of the optical system was noted. Then the filters were installed in the flow, and the tests were repeated. The change in the response of the optical system then represented the effect of the filters.

When these experiments began, the optical cavity consisted simply of a pair of mirrors, a filter, and a detector installed just downstream of the exit pipe of the gas flow system. The mirrors themselves were mounted each within 2 in. on each side of the pipe flow. In this configuration, the mirrors became clouded with condensed water vapor from the surrounding air because they were chilled by the expanded, cooled N_2 flow. Therefore, an alternate cavity system was installed (Figure 6) that consisted of a central section through which the flow was channelled with wings on both sides that led to the mirrors. It was hoped that the flow would have a less chilling effect on the mirrors since they were now more remote from the flow. This system worked fairly well. When oil was injected into the flow, the transmitted intensity, as observed by the photomultiplier tube, was reduced. However, condensed water vapor still formed on the mirrors, somewhat compromising the measurements. Probably the best way to perform this experiment is with an arrangement whereby the mirrors are enclosed in the cavity with the flow so that no condensation can form on them from air outside the cavity. Construction of such a cavity in which mirror position control is established using flexible cables connected to the mirrors through sealed ports in the cavity walls is quite practical. However, the evaluation of the filters by means of a gravimetric technique going on in parallel with the optical method has been completed. The need for the more sophisticated optical methods seems to have abated.

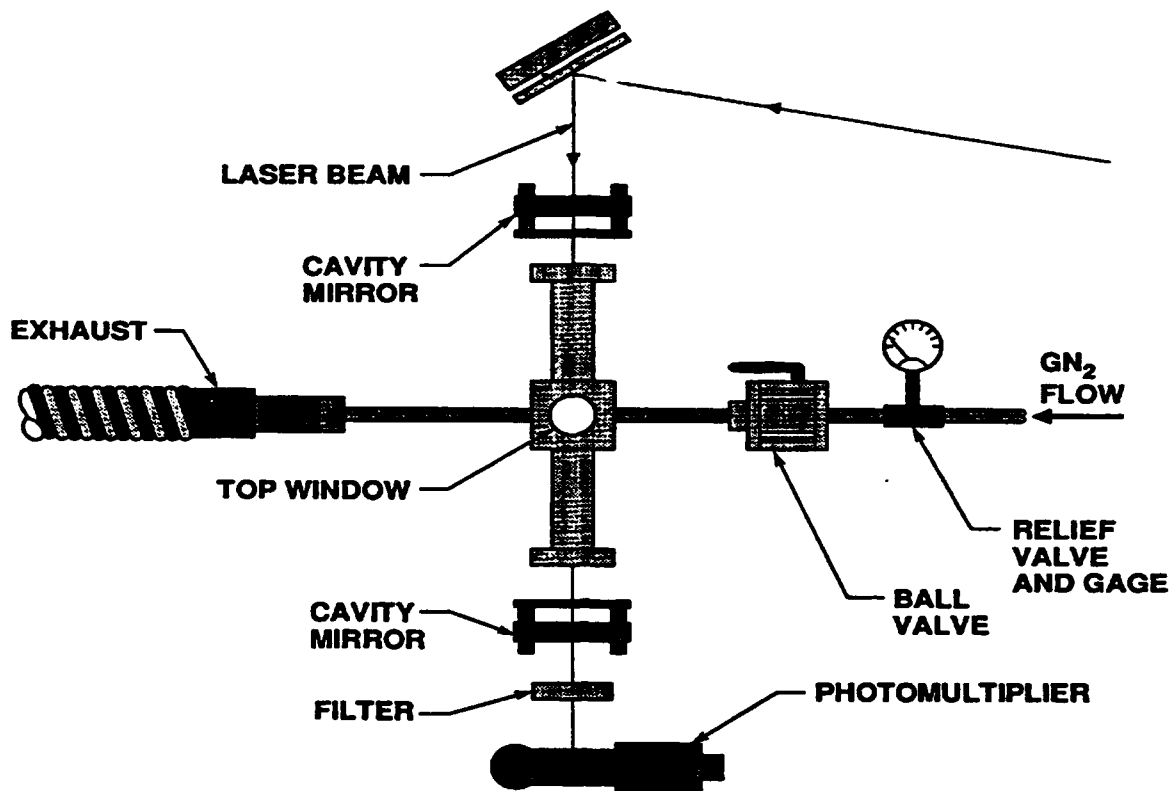

Figure 6. Improved cavity system for employment of activity attenuation technique.

5. RESULTS AND DISCUSSION

With the exception of the last four runs (15–18), the pressure in the test section was maintained at 150 psig, and the pressure upstream of the throat was set at 315 psig to ensure the choke condition throughout all runs. For these pressure conditions, two orifices with appropriate throat diameters were used to provide a moderate GN₂ flow rate of 200 scfm and a low GN₂ flow rate of 25 scfm.

Results for all runs (1–18) are tabulated in Table 1. A description of each run, differences with previous runs, and important observations made during and after the tests will be stated herein.

Run 1:

This was a baseline run for which the apparatus included three viewports placed before, between, and after the two filters (Figure 7). Prior to insertion into their cannisters, the two filters were weighed for gravimetric purposes. The larger orifice was mounted, and a 200 scfm flow rate of GN₂ was established in the line. Oil was injected into the gaseous nitrogen stream at a rate of 0.7 g/min, which corresponded to an oil loading of 104 ppm (by weight) relative to the GN₂. Optical diagnostics were set for the Mie scattering of droplets illuminated by the laser sheet. The test ran for 5 minutes, during which time several important observations were made. The viewports became foggy quickly within 20 seconds into the run. Obviously, the high flow rate of GN₂ through the tube and a tremendous pressure drop across the inlet regulator had chilled the copper tubes and led to condensation of the moisture in the air, causing foggy windows. Another observation was agglomeration of oil droplets on the first viewport. Upon arriving at the first viewport, the majority of oil droplets separated from the GN₂ stream and splashed against the window. This and the fog problem made the employment of the laser diagnostic technique impossible at the first viewport. No oil was detected at

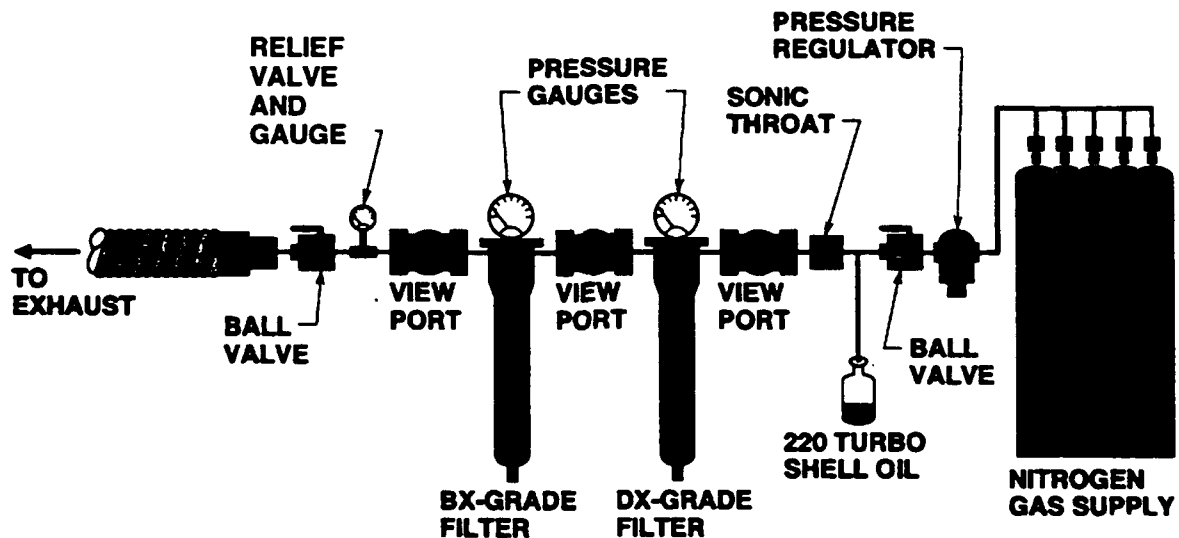

Figure 7. Schematic of test apparatus with three viewports placed before, between, and after the filters (Run 1).

Table 1. Reduced Data for All Runs.

Run No.	Test Duration (min)	Plenum Pressure (psig)	Test Section Pressure (psig)	GN ₂ Flow Rate (SCFM)	Oil Injection Rate (g/min)	Oil Loading Relative to GN ₂ (ppm)	Oil added to Saturate DX Filter (g)	Oil Standing in U-Tube (g)	Filter Mass Addition or Loss (g)	
									DX-Filter	BX-Filter
1	5	315	150	200	0.70	104	Fresh Filter	Straight Tube	0.88	0
2	2	315	150	200	0.70	104	Fresh Filter	Straight Tube	0.32	0
3	4	315	150	200	0.70	104	Fresh Filter	Straight Tube	0.15	0
4	5	315	150	25	0.70	833	Fresh Filter	Straight Tube	0.78	0
5	30	315	150	25	0.35	416	340	Straight Tube	-89.38	0.10
6	0.5	315	150	200	—	—	Fresh Filter	92.50	83.49	0.84
7	0.5	315	150	200	—	—	358	92.50	-95.08	107.90
8	0.5	315	150	200	—	—	Fresh Filter	15.50	10.16	0.37
9	5	315	150	25	0.10	119	No Filter	Straight Tube	No Filter	No Filter
10	5	315	150	25	0.10	119	No Filter	Straight Tube	No Filter	No Filter
11	5	315	150	25	0.35	416	No Filter	Straight Tube	No Filter	No Filter
12	1	315	150	200	0.10	15	No Filter	Straight Tube	No Filter	No Filter
13	1	315	150	200	0.03	5	No Filter	Straight Tube	No Filter	No Filter
14	1	315	150	200	0.03	5	No Filter	Straight Tube	No Filter	No Filter
15	10	105	45	10	—	—	368	Straight Tube	-88.72	0
16	10	45	15	5	—	—	352	Straight Tube	-65.87	0
17	2	105	45	10	—	—	Fresh Filter	91.14	30.09	0
18	2	45	15	5	—	—	Fresh Filter	90.09	10.14	0

the second and third viewports. Windows became foggy, but not as badly as those of the first viewport. More importantly, no increase in the scattered light signal was detected immediately downstream of the second filter (BX-grade). Furthermore, careful wipe inspection immediately downstream of the first filter showed no trace of oil. This was indicative of the fact that for the conditions described for Run 1, the first filter alone was sufficient to extract the oil from the GN₂ stream. The same conclusions were arrived at through gravimetric analysis, where a slight increase (0.88 grams) in the mass of the DX-grade filter was detected, while no change in the mass of the BX-grade filter was observed. Needless to say, the slight increase in the mass of the first filter could not account for total mass of the oil (3.5 grams) injected into the gaseous stream. That is, a substantial amount of oil had been trapped in the first viewport, and a considerable amount of oil had coated the tube walls. In fact, to account for the balance of the oil, the system was partially disassembled, and the first viewport and lines were removed to be wiped. By carefully weighing the wipe paper before and after the wipe, nearly all the mass of the oil was accounted for.

Run 2:

In the previous run, it was demonstrated that a substantial amount of oil was trapped in the first viewport. We were concerned that perhaps the amount of oil reaching the first filter was so little that it made the test trivial. In other words, the filter was not subjected to a severely contaminated flow so we could decisively assess the effectiveness of the filters in extracting oil from the GN₂ stream. Thus, viewport no. 1 was replaced by a straight tube (Figure 8). The laser sheet technique remained the optical diagnostic technique. Gravimetric analysis and wipe inspection were also employed. The test ran for 2 minutes. Two remaining viewports, once again, became foggy within 15 seconds into the run. No increase in the Mie scattered light was observed by the detector. No change in the mass of the second filter was observed, while the first filter showed a slight increase (0.32 grams) in its mass. Once again, the difference between the mass of the injected oil and that absorbed by the DX-filter was

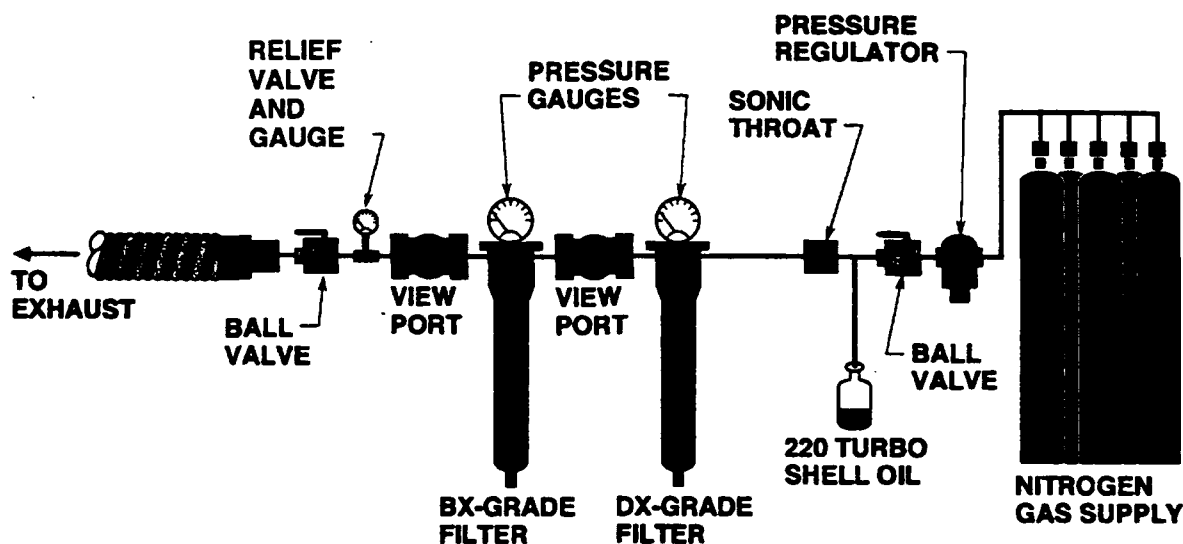

Figure 8. Schematic of test apparatus with two viewports placed between and after the filters (Runs 2, 3, and 4).

accounted for by wiping off the inner walls of the line. Similar to the previous run, the amount of oil absorbed by the filter in this run is considerably less than that collected by wiping the inner wall. In other words, a good portion of the oil injected into the stream went to coat the walls, and only a small fraction of the oil reached the upstream filter. Thus, knowing the mass flow rate of the oil injected into the stream was not sufficient for determining the amount of oil reaching the first filter. One way to circumvent this problem was to coat the walls with oil prior to inserting new filter cartridges. Fresh filter cartridges were then placed in the flow at the start of a new run.

Run 3:

To increase the sensitivity of our diagnostic technique, the cavity attenuation technique was employed at the downstream viewport replacing the laser sheet illumination technique. Prior to injecting oil in the stream, gaseous nitrogen flowed through the lines to set the desired pressure in the test section (Figure 8). During this period, while flow was being established, the GN₂ flow cleaned the surface of the mirrors, creating a higher gain cavity. This was detected by observing the signal from the photomultiplier tube to exhibit an amplification relative to the baseline signal obtained through the calibration. This was testimony to the very high sensitivity of this technique. GN₂ flowed through the system for 1 minute before any oil was injected into the stream. Oil was injected at the same rate as for previous runs (0.7 g/min) for a duration of 3 minutes. No attenuation of signal from the cavity was observed during this period, highlighting the fact that no oil had reached the downstream viewport. Gravimetric data shown in Table 1 are further evidence in support of this claim. Again, no increase in mass was observed in the BX-grade filter whereas a slight mass increase was detected in the DX-grade filter. Moreover, close visual inspection of the viewport located between the two filters and thorough wipe inspection of the line joining the two filters showed no trace of oil whatsoever. This meant that, once again, no oil was able to escape the first filter.

Runs 4-8:

To further expedite our response to the request of the Program Office, it was decided to defer employment of either optical diagnostic technique to later runs and rely solely on the gravimetric technique for quantitative analysis. After all, previous runs had clearly demonstrated that the gravimetric technique was a very reliable and convenient method for evaluating the effectiveness of the filtering system. As a result, we had acquired confidence in employment of this technique.

Hence, for Runs 4-8, no optical diagnostics were employed. Run 4 was conducted to assess the effectiveness of the filters while operating below 20% of rated flow. This was done to ensure the adequacy of the filters at low flow rates (some literature had indicated a loss in filter efficiency at low flow rates). Thus, the small nozzle mounted in the line to provide 25 scfm of GN₂. The same rate of oil loading was maintained, i.e., 0.7 g/min, which corresponds to an oil loading of 833 ppm (by weight). The apparatus remained the same as in the two previous runs (Figure 8). Duration of the run was 5 minutes, after which time a measurable increase in the mass of the DX-filter was noted, while no change in mass for the BX-filter was detected.

Prior to conducting Run 5, a decision was made to replace the viewport positioned between the two filters with a straight tube (Figure 9). This was done to prevent the possibility of oil being trapped in the viewport and, hence, not reaching the downstream filter. Also, the DX-grade filter was thoroughly soaked in an oil bath. Nearly 340 grams of oil were absorbed

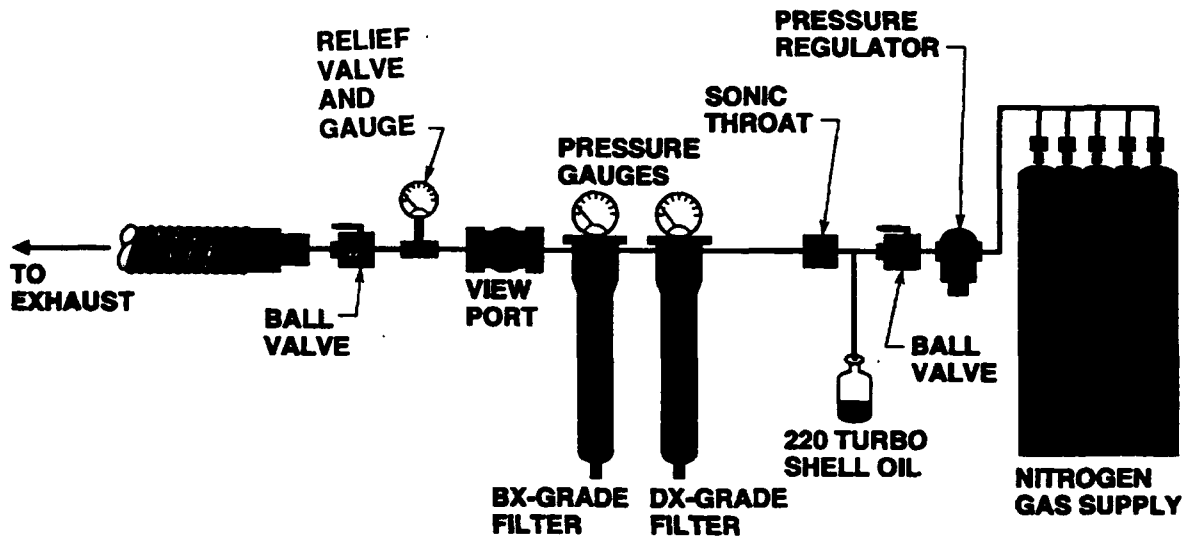

Figure 9. Schematic of test apparatus with one viewport placed downstream of the second filter (Runs 5, 15, and 16).

by the DX-filter, the initial mass of which was measured to be 128 grams. This was done to evaluate the effectiveness of the filter system under the condition where the upstream filter had absorbed so much oil that the filter fibers were saturated. In the field, this condition is unlikely to be encountered since the filter cartridges are to be replaced periodically by new ones long before they are saturated with oil. However, this test was meant to simulate a worst-case scenario. The test was run for a long time (30 minutes) at 25 scfm of GN₂ flow rate. Throughout the run, oil was injected into the stream at 0.35 g/min, which corresponds to 416 ppm oil loading. Gravimetric analysis revealed that the saturated filter (upstream) had lost 90 grams of oil, of which a great portion (85 grams) had dripped down the cartridge into the filter holder cannister. It was interesting to observe that for the first time, through the experiment, the BX-grade filter (downstream) had absorbed a small amount of oil (0.1 gram). Careful wipe inspection of the downstream viewport (the only viewport remaining in the system) assured us that no oil had escaped the BX-filter. So, the combination of two filters placed in series was adequate to prevent oil from escaping the filter system, even though the first filter was saturated with oil.

Run 6 was done to evaluate the adequacy of the filter system under another harsh condition. The filters were subjected to impingement of a "slug" of oil such as might be found at a low point in the line at the launch site. There was a concern that rapid impingement of a slug of oil may overwhelm the filters and allow oil to pass through the filter system. In order to collect a substantial amount of oil standing in line, a U-tube was installed upstream of the filters (Figure 10). 92.5 grams of oil was poured into the U-tube prior to allowing the flow of GN₂. Nitrogen then flowed at 200 scfm for 0.5 min. Post-mortem observations showed that upstream and downstream filters had absorbed 83.5 and 0.84 grams of oil, respectively. No trace of oil was detected downstream of the second filter.

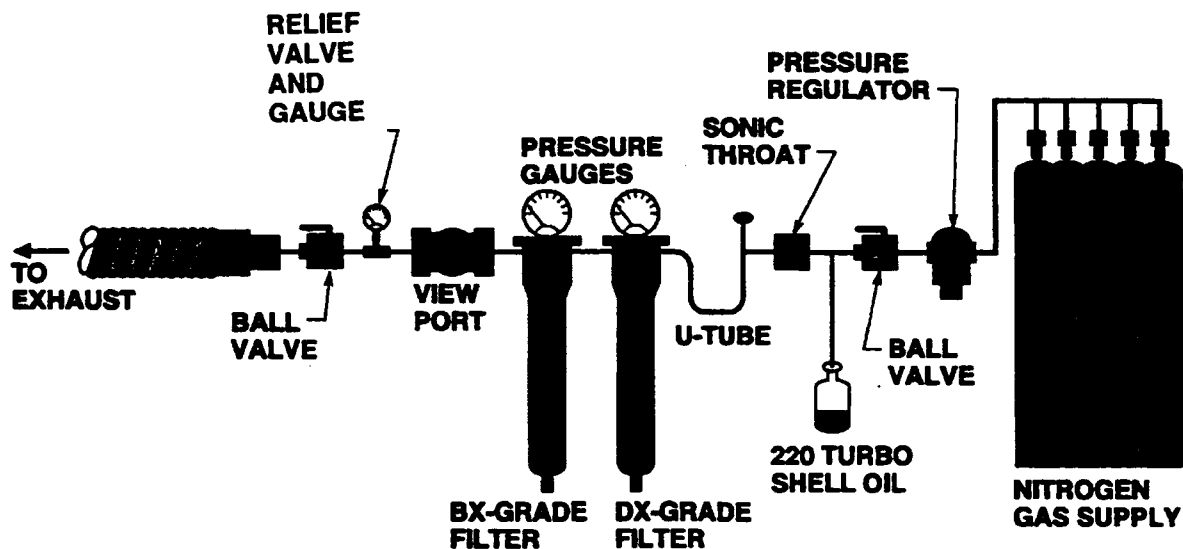

Figure 10. Schematic of test apparatus with U-tube for oil impingement tests (Runs 6, 7, 8, 17, and 18).

Run 7 was the most severe condition to which the filter system was subjected. Essentially, Run 6 was repeated with the difference that upstream filter element was saturated with oil as in Figure 10. Prior to the run, 92.5 grams of oil was poured in the U-tube, and nearly 358 grams of oil was added to a fresh DX-grade cartridge. GN₂ flowed at 200 scfm for 0.5 min. The upstream filter lost 95 grams of oil, while the downstream filter captured 108 grams of oil; however, no oil escaped from the second filter.

Run 8 was intended to determine whether an oil “puddle” would be entrained by the gaseous stream, and whether the filters adequately captured the entrained oil. Thus, 15.5 grams of oil was poured in the U-tube (Figure 10) so that the oil puddle was not obstructing the GN₂ flow (i.e., the gaseous stream could flow over the puddle). After 0.5 min at 200 scfm of GN₂, the upstream and downstream filters had captured 10.15 and 0.37 grams of oil, respectively. Close observation and wipe inspection immediately downstream of the filters revealed no trace of oil.

Runs 9-14:

Previous runs had convinced us that the proposed filter system could effectively remove oil from the GN₂ stream over a wide range of conditions, some of which were extremely harsh. At this point, our observations and findings were relayed to the Program Office with our preliminary endorsement of the proposed filter system. However, to further quantify our findings, and to detect oil contamination levels on the order of 5 ppm or better, we turned our attention back to the laser diagnostic technique; in particular, to the more promising cavity attenuation approach. Runs 9-14 were conducted to establish a ceiling for detection capability. For these runs, both filters were removed (Figure 11), and oil loading was controlled to its minimum injection limit (i.e., motors lowest rpm). The signal from the photomultiplier tube was detected before injection of the oil into the GN₂ stream and compared with the signal after oil injection. Run 9 lasted 5 minutes, during which time GN₂ flowed at 25 scfm, and oil

loading was kept at 0.1 g/min. This corresponds to 120 ppm of oil loading. The signal obtained from the PM tube was immediately attenuated by injection of the oil, highlighting the fact that the employed diagnostic technique can easily detect the arrival of the oil aerosols into the cavity. Run 10 was identical to the previous run to establish the repeatability of the diagnostic technique. Run 11 was conducted to verify that higher oil loading would result in more attenuation of the cavity signal. When oil loading was increased to 416 ppm, the signal indeed was more attenuated compared with that obtained by Runs 9 and 10. For Run 12, GN₂ flowed at 200 scfm for 1 minute, while oil loading was maintained at 0.1 g/min (15 ppm). The signal from the PM tube immediately responded to the oil injection, indicating higher loss in the cavity.

For the purpose of achieving lower oil contamination levels, the oil injecting mechanism was modified. The rod responsible for drawing the oil reservoir toward the motor was replaced by a rod with a finer thread. This, combined with running the motor at an even lower rpm, resulted in oil injection at a rate of 0.03 g/min. Runs 13 and 14 were conducted with the modified injection mechanism. The apparatus, however, remained as shown in Figure 11. GN₂ flowed at 200 scfm for 1 minute. Oil was injected into the stream 10 seconds into the run at a rate of 0.03 g/min, which corresponds to an oil loading slightly less than 5 ppm. The cavity signal was attenuated shortly after oil injection, testifying that our diagnostic technique can conveniently detect contamination levels lower than 5 ppm. What needs to be kept in mind is that the contamination level reported here is the injected level. Undoubtedly, the amount of oil reaching the cavity is far lower than the injected level. In other words, the cavity attenuation technique is even more sensitive than what is reported here. In fact, we believe the technique can be fine tuned and slightly modified to be far more sensitive than 1 ppm; perhaps on the order of parts per billion.

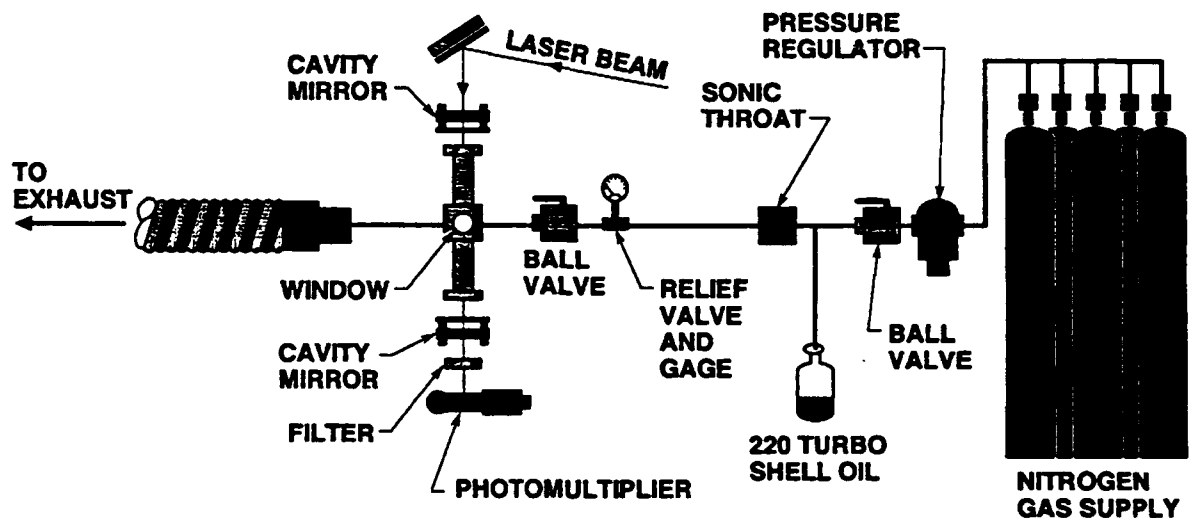

Figure 11. Schematic of test apparatus with no filters to demonstrate sensitivity of laser diagnostic technique (Runs 9-14).

Runs 15-18:

Four runs were conducted to evaluate the effectiveness of the filters under unfavorable conditions at lower flow rates. This was achieved by lowering the operating pressure and not by installing smaller throat nozzles. In so doing, the adequacy of the filter operating at lower pressures could also be tested. For Run 15, the test section was maintained at 45 psig, while the upstream section of the throat was kept at 105 psig (i.e., flow was choked). The apparatus was assembled as shown in Figure 9. GN₂ flowed at 10 scfm for 10 minutes. The upstream filter had been soaked in an oil bath prior to the run. Post mortem analysis showed that the upstream filter lost 89 grams of oil, while the downstream filter showed no increase in mass. Most of the oil was recovered from the pool at the bottom of the first filter cannister.

Comparing the findings of this run with those obtained for Run 5 shows that momentum of the GN₂ stream is important in passing the contaminants through the filter fibers. That is why a small amount of oil reached the downstream filter in Run 5, whereas no oil was able to escape the upstream filter in Run 15.

Run 16 was essentially a repeat of Run 15 (Figure 9), with the difference that GN₂ flow rate was decreased to 5 scfm by lowering the test section pressure to 15 psig. Observations similar to those for Run 15 were made. Comparing the reduced data for these two runs shows that lower momentum GN₂ flow forced less oil through the DX-filter.

In Runs 17 and 18, the upstream filter was subjected to impingement of a slug of oil, while GN₂ flowed at 10 and 5 scfm, respectively. The pressure conditions similar to those described for Runs 15 and 16 were maintained. The apparatus, however, was reassembled as shown in Figure 10. Post-test observations revealed that only a small portion of the oil in the U-tube was pushed toward the filters, and a good portion of the oil was still standing in the U-tube. This was indicative of the fact that GN₂ stream did not possess enough momentum to punch the oil toward the filters. Only the top portion of the standing oil, necessary to maintain the desired flow rate, was pushed through. Both tests were run for 2 minutes throughout which the upstream filter absorbed the on-coming oil and did not let any oil go toward the downstream filter. Table 1 shows that for Run 17, the upstream filter had extracted nearly 30 grams of oil from the GN₂ stream flowing at 10 scfm, while only 10 grams of oil was extracted in Run 18 where GN₂ flowed at 5 scfm. This reiterates the fact that the lower momentum stream had extracted less oil from the U-tube to push toward the filters. Table 1 also indicates no detectable change in the mass of the downstream filter for these tests (Runs 17 and 18), reconfirming that the double filter system is more than adequate for extracting oil from the gaseous nitrogen stream.

6. CONCLUSIONS AND RECOMMENDATIONS

The proposed double-filter combination proved to be an effective system for extracting oil from the GN_2 stream. Subjecting the filters to a series of adverse and harsh tests demonstrated that the combination of the two filters is more than adequate for meeting the stringent launch pad requirements. The severe and harsh conditions were simulated by.

- subjecting the filters to impingement of a slug of oil,
- saturating the upstream filter with oil prior to the test, and
- impinging the oil slug onto a saturated filter.

Under all these conditions, with either high or low GN_2 flow rates operating at nominal or low pressures, the previously described double filter system did not allow any oil to escape. In fact, with the exception of Run 7, in which a saturated upstream filter was subjected to impingement of an oil slug (harsh case tested), the first filter was nearly sufficient in extracting oil from the gaseous nitrogen stream. However, to be quite sure and confident that the entrained oil is thoroughly and completely eradicated from the GN_2 stream, the proposed double-filter system is an extremely reliable combination, which we endorse.

In the course of conducting these experiments, a novel optical diagnostic technique was developed, which was fairly easy to implement. By conducting a series of calibration tests, it was demonstrated that the cavity attenuation technique was capable of providing needed sensitivity to measure contamination levels on the order of a few parts per million. We are convinced, however, that this technique can be slightly modified and fine tuned to provide far better sensitivity for measuring contamination levels, perhaps on the order of parts per billion. The diagnostics may then be packaged in a compact compartment to be carried to the launch site for *in situ* contamination measurements. This technique will detect existence of oil and any other contaminants entrained in the gaseous stream.

The idea of placing a viewport downstream of the second filter was not initially set forth as a means of detection. It was done to allow optical access to the inside of the tube. However, in the course of the experiments, we discovered serendipitously that the viewport can serve as an excellent witness window. Upon reaching the viewport, the lower momentum oil stream separated from the higher momentum GN_2 stream and was splashed against the side windows. It was interesting to observe that even at the lowest rate of oil loading (5 ppm), the viewport's windows became spotty immediately after injection of oil. In other words, even at such low levels of contamination, the viewport can serve as a witness window for detecting oil in the stream. All things considered, we highly recommend the installation of a viewport immediately downstream of the second filter. This perhaps will be the most economical and most convenient method for detection of oil at such low levels and can be easily implemented at the launch site.

In addition to the above recommendations, we recommended installation of a transparent tube below the drain hole of the filter cannisters. The agglomeration of a pool of oil at the bottom of each filter cannister needs to be closely observed so that the filter cartridges can be replaced before they become saturated with oil. A graduated transparent tube can be a convenient way of detecting a filter cartridge in need of replacement.

TECHNOLOGY OPERATIONS

The Aerospace Corporation functions as an "architect-engineer" for national security programs, specializing in advanced military space systems. The Corporation's Technology Operations supports the effective and timely development and operation of national security systems through scientific research and the application of advanced technology. Vital to the success of the Corporation is the technical staff's wide-ranging expertise and its ability to stay abreast of new technological developments and program support issues associated with rapidly evolving space systems. Contributing capabilities are provided by these individual Technology Centers:

Electronics Technology Center: Microelectronics, solid-state device physics, VLSI reliability, compound semiconductors, radiation hardening, data storage technologies, infrared detector devices and testing; electro-optics, quantum electronics, solid-state lasers, optical propagation and communications; cw and pulsed chemical laser development, optical resonators, beam control, atmospheric propagation, and laser effects and countermeasures; atomic frequency standards, applied laser spectroscopy, laser chemistry, laser optoelectronics, phase conjugation and coherent imaging, solar cell physics, battery electrochemistry, battery testing and evaluation.

Mechanics and Materials Technology Center: Evaluation and characterization of new materials: metals, alloys, ceramics, polymers and their composites, and new forms of carbon; development and analysis of thin films and deposition techniques; nondestructive evaluation, component failure analysis and reliability; fracture mechanics and stress corrosion; development and evaluation of hardened components; analysis and evaluation of materials at cryogenic and elevated temperatures; launch vehicle and reentry fluid mechanics, heat transfer and flight dynamics; chemical and electric propulsion; spacecraft structural mechanics, spacecraft survivability and vulnerability assessment; contamination, thermal and structural control; high temperature thermomechanics, gas kinetics and radiation; lubrication and surface phenomena.

Space and Environment Technology Center: Magnetospheric, auroral and cosmic ray physics, wave-particle interactions, magnetospheric plasma waves; atmospheric and ionospheric physics, density and composition of the upper atmosphere, remote sensing using atmospheric radiation; solar physics, infrared astronomy, infrared signature analysis; effects of solar activity, magnetic storms and nuclear explosions on the earth's atmosphere, ionosphere and magnetosphere; effects of electromagnetic and particulate radiations on space systems; space instrumentation; propellant chemistry, chemical dynamics, environmental chemistry, trace detection; atmospheric chemical reactions, atmospheric optics, light scattering, state-specific chemical reactions and radiative signatures of missile plumes, and sensor out-of-field-of-view rejection.