



**US Army Corps
of Engineers**
Waterways Experiment
Station

Technical Report GL-93-17
July 1993

AD-A268 567



Site Investigations with the Site Characterization and Analysis Penetrometer System at Fort Dix, New Jersey

*by Landris T. Lee, Jr., Amy M. Chrestman,
Donald H. Douglas
Geotechnical Laboratory*

*Jeff F. Powell
Instrumentation Services Division*

*Philip G. Malone
Structures Laboratory*

DTIC
S **ELECTE** **D**
AUG 26 1993
B

Approved For Public Release; Distribution Is Unlimited

93 8 25 001

93-19896

Prepared for U.S. Army Environmental Center

DISCLAIMER NOTICE

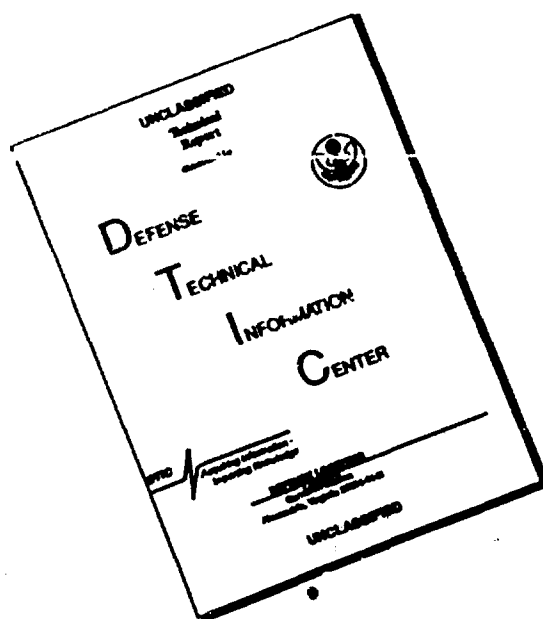

**THIS DOCUMENT IS BEST
QUALITY AVAILABLE. THE COPY
FURNISHED TO DTIC CONTAINED
A SIGNIFICANT NUMBER OF
PAGES WHICH DO NOT
REPRODUCE LEGIBLY.**

The contents of this report are not to be used for advertising, publication, or promotional purposes. Citation of trade names does not constitute an official endorsement or approval of the use of such commercial products.



PRINTED ON RECYCLED PAPER

DISCLAIMER NOTICE

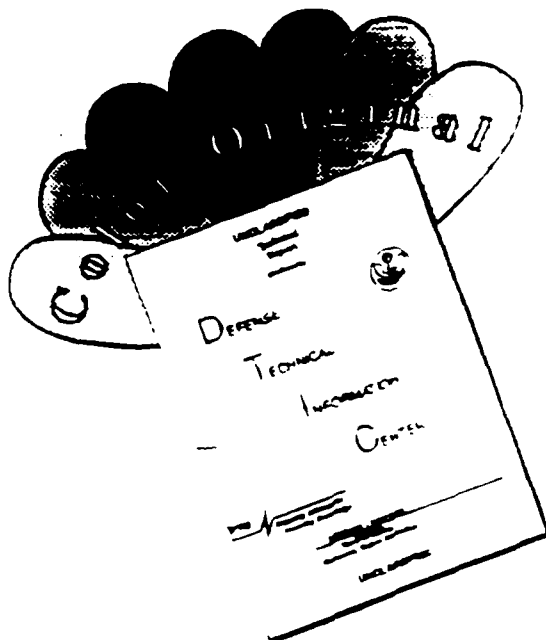

THIS DOCUMENT IS BEST QUALITY AVAILABLE. THE COPY FURNISHED TO DTIC CONTAINED A SIGNIFICANT NUMBER OF COLOR PAGES WHICH DO NOT REPRODUCE LEGIBLY ON BLACK AND WHITE MICROFICHE.

Technical Report GL-93-17
July 1993

Site Investigations with the Site Characterization and Analysis Penetrometer System at Fort Dix, New Jersey

by Landris T. Lee, Jr., Amy M. Chrestman,
Donald H. Douglas
Geotechnical Laboratory

Jeff F. Powell

Instrumentation Services Division

Philip G. Malone

Structures Laboratory

U.S. Army Corps of Engineers
Waterways Experiment Station
3909 Halls Ferry Road
Vicksburg, MS 39180-6199

Final report

Approved for public release; distribution is unlimited

Prepared for **U.S. Army Environmental Center
Aberdeen Proving Ground, MD 21010-5401**



**US Army Corps
of Engineers**
Waterways Experiment
Station

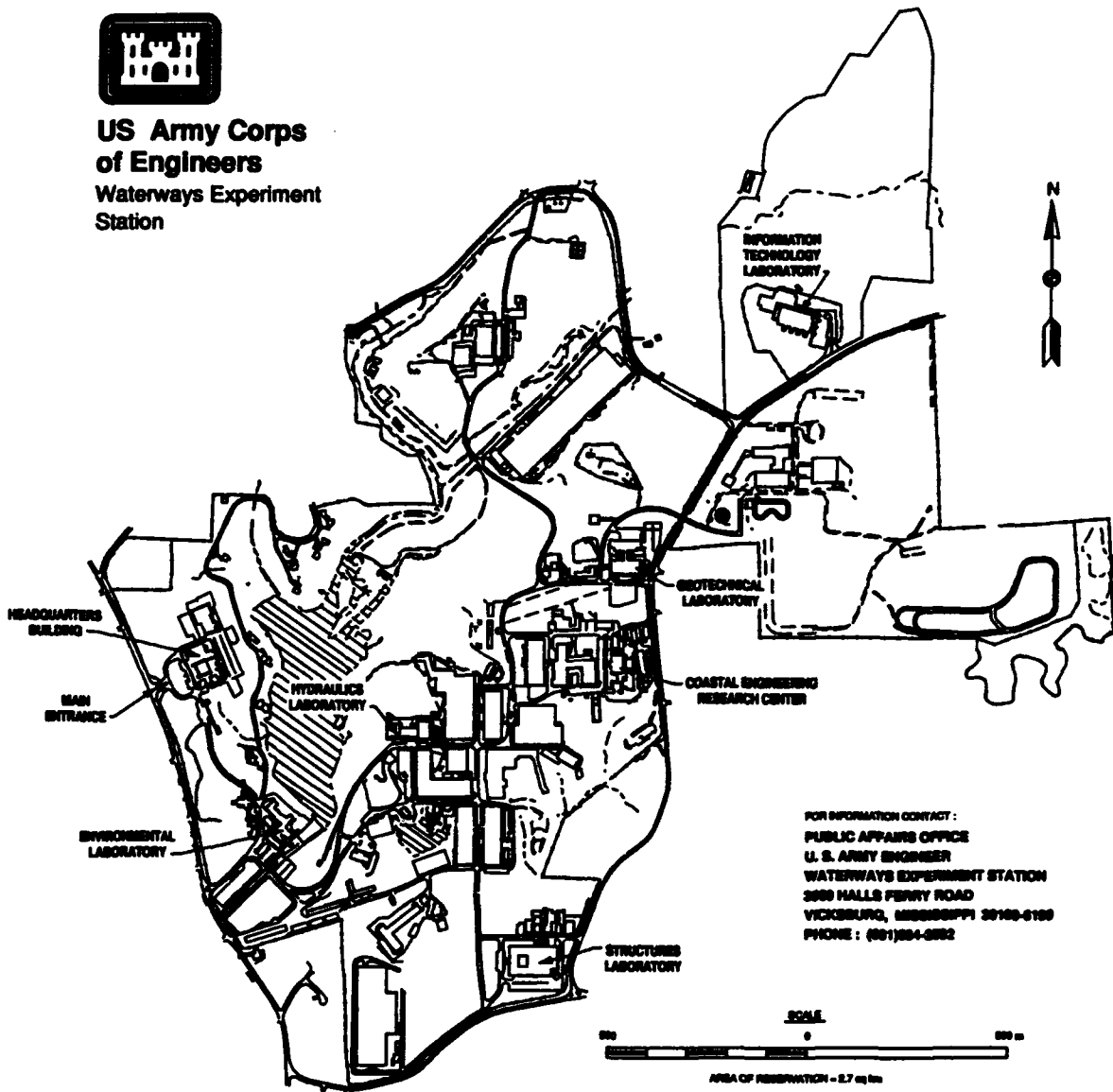

Waterways Experiment Station Cataloging-in-Publication Data

Site investigations with the Site Characterization and Analysis Penetrometer System at Fort Dix, New Jersey / by Landris T. Lee, Jr. ... [et al.]; prepared for U.S. Army Environmental Center.

440 p.: ill.; 28 cm. -- (Technical report; GL-93-17)

Includes bibliographical references.

1. Oil pollution of soils -- New Jersey -- Fort Dix. 2. Soil penetration test. 3. Fluorimeter. 4. Hazardous wastes -- New Jersey -- Fort Dix. I. Lee, Landris T. II. U.S. Army Environmental Center. III. U.S. Army Engineer Waterways Experiment Station. IV. Series: Technical report (U.S. Army Engineer Waterways Experiment Station); GL-93-17.

TA7 W34 no.GL-93-17

5426 Boiler Plant	92
5700 Area Motor Pool	94
5800 Area Motor Pool	96
5881 Boiler Plant and Incinerator	101
5900 Area Motor Pool	104
8100 Area Motor Pool	104
8132 Hazardous Waste Storage Area	107
5—Summary, Conclusions, and Recommendations	110
Summary	110
Fort Dix site investigation/POL screening	110
SCAPS demonstration	111
Conclusions	111
Fort Dix site investigation/POL screening	111
SCAPS demonstration	111
Recommendations	113
Fort Dix site investigation/POL screening	113
SCAPS demonstration	114
Bibliography	116
Appendixes (Data Plots from Penetrometer Pushes)	
Appendix A: Bivouac Area 5 Washrack	A1
Appendix B: Fire Tank Training Area	B1
Appendix C: 4300 Area Motor Pool	C1
Appendix D: 4400 Area Motor Pool	D1
Appendix E: 5252 Boiler Plant	E1
Appendix F: 5326 Boiler Plant Area (Laundry)	F1
Appendix G: 5426 Boiler Plant	G1
Appendix H: 5700 Area Motor Pool	H1
Appendix I: 5800 Area Motor Pool	I1
Appendix J: 5881 Boiler Plant and Incinerator	J1
Appendix K: 5900 Area Motor Pool	K1
Appendix L: 8100 Area Motor Pool	L1
Appendix M: 8132 Hazardous Waste Storage Area	M1

SF 298

List of Figures

Figure 1. Site map showing location of Fort Dix, New Jersey	2
Figure 2. General geologic cross section of New Jersey (from ICF Kaiser 1992)	6

Figure 3.	Geologic map of Fort Dix	7
Figure 4.	Photograph of the penetrometer truck and grouting trailer . .	12
Figure 5.	Sectional view of penetrometer equipped to measure soil strength	16
Figure 6.	Calibration curve for the strain-gauged penetrometer cone and friction sleeve	17
Figure 7.	Chart for soil classification scheme	18
Figure 8.	Schematic of cone penetrometer system	20
Figure 9.	Calibration curves for fluorometer based on fuel oil in local sand	22
Figure 10.	Photograph of a heterogeneously contaminated soil sample .	24
Figure 11.	Map of investigation site locations	33
Figure 12.	Bivouac Area 5 Washrack site map	37
Figure 13.	Fire Tank Training Area site map	39
Figure 14.	Fire Tank Training Area 3-D visualization, view 1	41
Figure 15.	Fire Tank Training Area 3-D visualization, view 2	45
Figure 16.	Fire Tank Training Area 3-D visualization, view 3	49
Figure 17.	Fire Tank Training Area 3-D visualization, view 4	53
Figure 18.	4300 Area Motor Pool site map	59
Figure 19.	4400 Area Motor Pool site map	62
Figure 20.	Fluorescence from spectra of deicing fluid and groundwater	70
Figure 21.	4400 Area Motor Pool 3-D visualization, view 1	73
Figure 22.	4400 Area Motor Pool 3-D visualization, view 2	77
Figure 23.	4400 Area Motor Pool 3-D visualization, view 3	81
Figure 24.	4400 Area Motor Pool 3-D visualization, view 4	85
Figure 25.	5252 Boiler Plant site map	89
Figure 26.	5326 Post Boiler Plant Area (Laundry) site map	90
Figure 27.	5426 Boiler Plant site map	93
Figure 28.	5700 Area Motor Pool site map	95
Figure 29.	5800 Area Motor Pool site map	97
Figure 30.	X-ray diffraction pattern from fluorescent mineral grains . .	99
Figure 31.	Fluorescent spectra	100
Figure 32.	5881 Boiler Plant and Incinerator site map	102
Figure 33.	5900 Area Motor Pool site map	105

Figure 34.	8100 Area Motor Pool site map	106
Figure 35.	8132 Hazardous Waste Storage Area site map	108

List of Tables

Table 1.	Summary of Sites Investigated at Fort Dix	35
Table 2.	Results of Laboratory Analysis for Total Organic Carbon (TOC) and Total Recoverable Petroleum Hydrocarbons (TRPH) for the Bivouac Area 5 Washrack Area Samples . .	38
Table 3.	Results of Laboratory Analysis for Polynuclear Aromatic Hydrocarbons (PAH) Compounds for the Bivouac Area 5 Washrack Area Samples	38
Table 4.	Results of Laboratory Analysis for TOC and TRPH for the Fire Tank Training Area Samples	57
Table 5.	Results of Laboratory Analysis for PAH Compounds for the Fire Tank Training Area Samples	58
Table 6.	Results of Laboratory Analysis for TOC and TRPH for the 4400 Area Motor Pool Samples	63
Table 7.	Results of Laboratory Analysis for PAH Compounds for the 4400 Area Motor Pool Samples	64
Table 8.	Results of Laboratory Analysis for TOC and TRPH for the 5326 Post Boiler Plant Area (Laundry) Samples	91
Table 9.	Results of Laboratory Analysis for PAH Compounds for the 5326 Post Boiler Plant Area (Laundry) Samples	92
Table 10.	Results of Laboratory Analysis for TOC and TRPH for the 5800 Area Motor Pool Samples	98
Table 11.	Results of Laboratory Analysis for PAH Compounds for the 5800 Area Motor Pool Samples	98
Table 12.	Results of Laboratory Analysis for TOC and TRPH for the 5881 Boiler Plant Samples	103
Table 13.	Results of Laboratory Analysis for PAH Compounds for the 5881 Boiler Plant Samples	103

Preface

The United States Army Engineer Waterways Experiment Station (WES) was tasked by the United States Army Environmental Center (AEC) to perform Site Characterization and Analysis Penetrometer System (SCAPS) site investigations at designated locations within the United States Army Fort Dix, New Jersey.

The AEC program called for the WES to conduct SCAPS field investigations using penetrometer-based sensors and samplers as screening-level tools in evaluating the level of contamination at areas within Fort Dix, designated by the AEC. The areas selected for investigation were suspected to contain subsurface contamination from petroleum, oil, and lubricants (POL). The SCAPS field investigations were conducted during the periods of 22 October through 8 December 1992, and 11 January through 13 February 1993. The AEC Project Officer was CPT Ronald N. Light. The Fort Dix Directorate of Public Works (DPW) Environmental and Natural Resources Branch Project Coordinators were Ms. Christine Dietrick and Ms. Ann Hawthorne.

The SCAPS field investigations were conducted by Messrs. Landris T. Lee, Jr., Karl F. Konecny, Donald H. Douglas (Geotechnical Laboratory); Donald Harris (Engineering and Construction Services Division); and Jeff F. Powell and Paul C. Dew (Instrumentation Services Division). Data processing, site mapping, and data visualization support personnel included Ms. Amy M. Chrestman (Geotechnical Laboratory), Mr. Raju Kala and Mr. J. D. Overton (Hilton Systems, Inc.).

Report preparation was done by Mr. Landris T. Lee, Jr., Ms. Amy M. Chrestman, Mr. Jeff F. Powell, Dr. Philip G. Malone (Structures Laboratory), and Mr. Donald H. Douglas. Sample analyses were performed by the Environmental Chemistry Branch, WES. Ms. Ann Strong supervised the analytical effort. The analysts include Mr. Richard Karn and Ms. Allyson Lynch (American Science International Corporation). Mineral x-ray diffraction analysis was accomplished by Mr. Jerry P. Burkes (Structures Laboratory). Mineral petrographic examination was accomplished by Mr. Danny Harrelson (Geotechnical Laboratory).

The project was supervised by Mr. Joseph R. Curro, Jr., Chief, Engineering Geophysics Branch, Mr. Mark Vispi, Chief, In Situ Evaluation Branch, Dr. A. G. Franklin, Chief, Earthquake Engineering and Geosciences Division,

and Dr. W. F. Marcuson III, Director, Geotechnical Laboratory. The project was under the Environmental Laboratory management of Mr. John H. Ballard, Dr. Jerome L. Mahloch (Program Manager), and Dr. John Harrison (Director).

At the time of publication of this report, Director of WES was Dr. Robert W. Whalin. Commander was COL Bruce K. Howard, EN.

Conversion Factors, Non-SI to SI Units of Measurement

Non-SI units of measurement used in this document can be converted to SI units as follows:

Multiply	By	To Obtain
acres	0.40486	hectares
feet	0.3048	meters
gallons	3.7854	liters
inches	2.54	centimeters
miles (US statute)	1.6093	kilometers
pounds (mass)	0.4535	kilograms
tons (2,000 pounds mass)	907.2	kilograms

1 Introduction

Overview

The United States Army Environmental Center (AEC), sponsored the United States Army Engineer Waterways Experiment Station (WES) to perform site characterization and screening activities at designated areas within the United States Army Training Center and Fort Dix (Fort Dix), New Jersey. Fort Dix is located in central New Jersey, within Burlington and Ocean Counties (Figure 1).

The Site Characterization and Analysis Penetrometer System (SCAPS) was deployed at Fort Dix from 22 October to 8 December 1992, and from 11 January to 13 February 1993. The total time on-site was 12 weeks, and 321 subsurface penetrations (285 for sensing and 36 for verification sampling) were made during this time (some to a depth over 50 ft). The investigations were conducted on 13 sites within Fort Dix as directed by the AEC Base Closure Division and the Fort Dix Directorate of Public Works (DPW).

Objective

The first objective of this task was to detect the presence and determine the approximate extent of petroleum, oil, and lubricant (POL) products suspected of contaminating the soil and groundwater under selected areas within select sites at Fort Dix. To accomplish the task, the SCAPS unit was directed to sites with either suspected or known POL contamination based on previous environmental studies conducted for Fort Dix and/or historical records of spills or leaks. The SCAPS data collected during the site investigations will assist ongoing and future planning operations directed toward site remediation efforts.

A second objective was to continue the demonstration phase of the SCAPS research and development effort. Further evaluation of the system capabilities and the identification of needed refinements to the existing SCAPS system were identified as goals in pursuing this field effort.

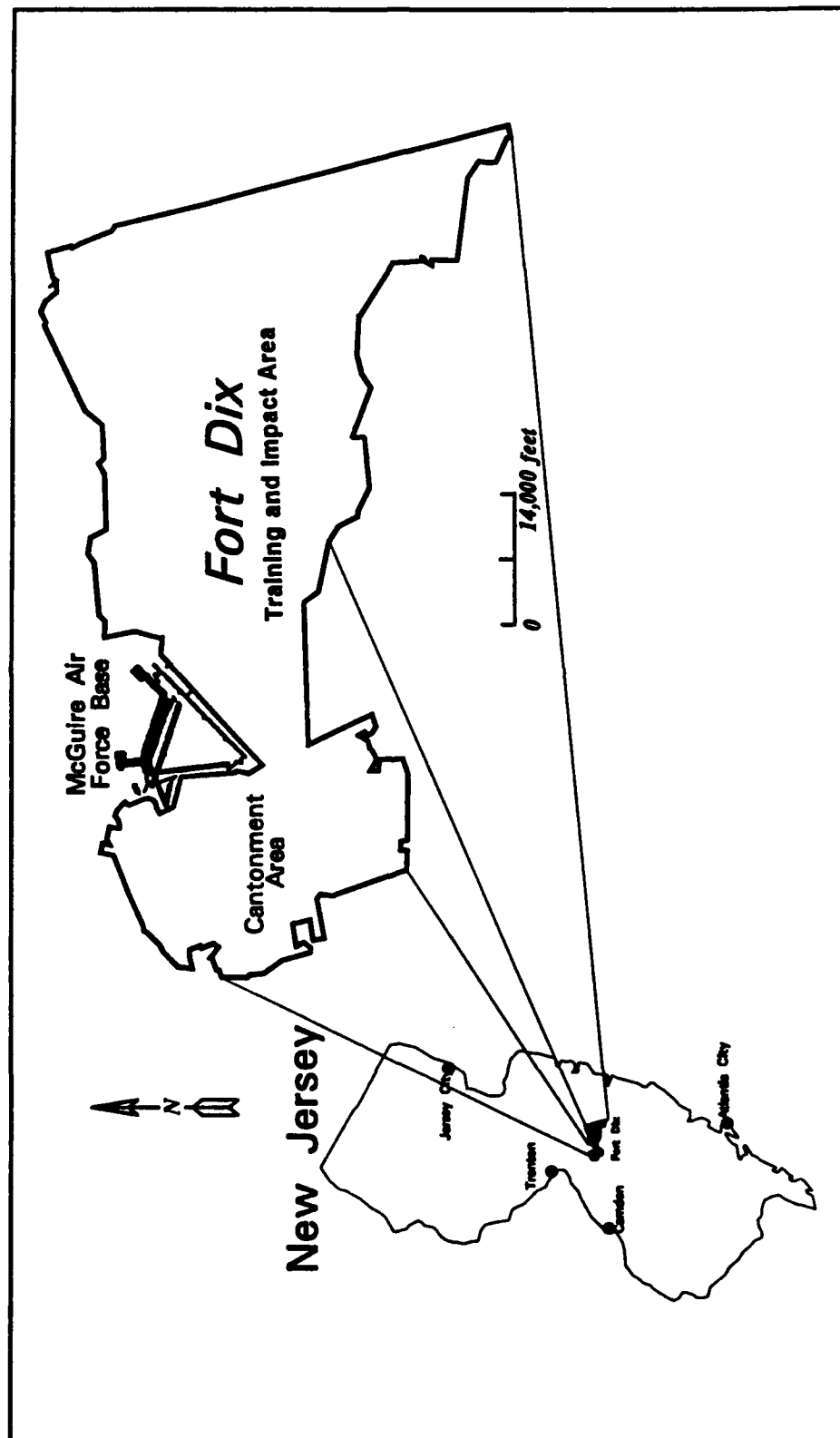

Figure 1. Site map showing location of Fort Dix, New Jersey

2 Site Description

Fort Dix History

The U.S. Army installation at Fort Dix is located in central New Jersey. It is situated on approximately 32,000 acres, 16 mile southeast of Trenton, New Jersey and 32 mile northeast of Philadelphia, Pennsylvania. The installation is bounded on the northeast by McGuire Air Force Base and Wrightstown, New Jersey; on the east by Lakehurst Naval Air Station; on the south by Browns Mills and Pemberton, New Jersey; and on the west by farming country within Burlington County, New Jersey. The installation is located approximately at 40°01' N; 74°52' W. The area is gridded by the Transverse Mercator New Jersey State Plane Coordinate System.

Fort Dix was initially designated as Camp Dix during World War I and served as a cantonment area and training post for troops who fought in that war. The post served as a reception, discharge, and replacement center for the Civilian Conservation Corps from 1933 to 1939. Camp Dix became a permanent Army installation and its name was changed to Fort Dix in 1939. During World War II, it served as a reception and training center. From 1947 to 1956, two divisions occupied Fort Dix: the 9th Division from 1947 to 1954, and the 69th Division from 1954 to 1956. In 1956 Fort Dix was officially named the United States Army Training Center and Fort Dix, and its mission did not change from 1956 until 1991.

Fort Dix began realignment in 1991 from the U.S. Army Training and Doctrine Command (TRADOC) to the U.S. Army Forces Command (FORSCOM). As of October 1992, FORSCOM became the major command at Fort Dix.

Site Investigations

Several studies have been published on the environmental effects of operations at Fort Dix. The significant studies are listed below in chronological order.

- a. Reports on pesticide distribution and monitoring were completed by the U.S. Army Environmental Hygiene Agency (USAEHA) in 1975 and 1985 (USAEHA 1975, 1985).**
- b. Installation Assessment of Fort Dix (BOMARC Site), was completed by the U.S. Army Toxic and Hazardous Materials Agency (USATHAMA) in 1977. This publication describes the results of a records search conducted on Fort Dix to estimate possible contamination by chemical, biological, and radiological material and to assess the possibility of contaminant migration beyond the installation boundary (USATHAMA 1977).**
- c. A report was prepared by Iffland, Kavanaugh, Waterbury, P.C. (IKW) on groundwater testing results at three locations on Fort Dix: the Golf Course Area, Transportation Motor Pool, and the area north of Dogwood Lake (IKW 1985).**
- d. An Environmental Noise Assessment for Fort Dix was completed by USAEHA in 1986 (USAEHA 1986).**
- e. A Remedial Investigation/Feasibility Study was performed for the Fort Dix Sanitary Landfill by Camp, Dresser, and McKee, Inc. (CDM 1986).**
- f. A Preliminary Assessment/Site Investigation of environmental conditions at Fort Dix was conducted by EA Engineering, Science, and Technology, Inc. (EA), under contract to USATHAMA. The report includes results from soil and groundwater investigations at 16 sites and geophysical surveys at four other sites (EA 1989).**
- g. A Remedial Investigation report was done by Dames and Moore, under contract to USATHAMA. The Remedial Investigation Phase I was conducted at 15 sites and Phase II was conducted at 9 sites. The purpose of the Remedial Investigation was to determine the nature and extent of water, soil, and sediment contamination caused by past operations at the studied sites, to evaluate the contaminant migration potential, and to assess risks to public health and the environment posed by contamination (Dames and Moore 1991).**
- h. Roy F. Weston, Inc. prepared an Enhanced Preliminary Assessment in March 1992, under contract to USATHAMA. This study identified 42 areas at Fort Dix requiring environmental evaluation (USATHAMA 1992).**
- i. ICF Kaiser Engineers, Inc. is under contract to AEC to conduct an Environmental Investigation/Alternatives Analysis (EI/AA) for 19 areas identified in the Weston Preliminary Assessment. These sites are classified as Areas Requiring Environmental Evaluation (AREEs), and a draft work plan for conducting the EI/AA has been submitted to AEC (ICF Kaiser 1992).**

The SCAPS field investigation sites coincide with several of the AREE's identified. All thirteen investigation sites (among others) are listed in the USATHAMA (1992) and ICF Kaiser (1992) reports (items *h* and *i*). Information from previous studies conducted by several of the above sources has been incorporated into this report.

Site Features

Physiography and topography

Fort Dix is located within Burlington and Ocean Counties, in southeastern New Jersey, in an area that is largely agricultural and lightly populated. Most of the land immediately west of Fort Dix is farmed, and most of the land to the east is forested. Burlington and Ocean Counties are within the northern Atlantic Coastal Plain physiographic province. The Atlantic Coastal Plain is characterized by flat to gently rolling topography. Elevation above mean sea level (MSL) changes from 170 ft in the northwest area of Fort Dix to 70 ft in the southeast area. The higher areas to the northwest are more arable and drier than the lower areas in the southeast.

Climate

The Fort Dix area has moderate temperatures, precipitation, and wind speeds. Average annual temperature in the area is 54°F, based on weather data from McGuire Air Force Base adjacent to Fort Dix. January, the coldest month, has an average temperature of 31°F. Average annual precipitation in the area is 44 in. and is fairly well distributed throughout the year. Wind speeds in the area average approximately 7 mph, and the prevailing direction is from the south during the summer months and the west/northwest during winter (ICF Kaiser 1992).

Geology

Fort Dix is located approximately 15 miles east of the Fall Line which separates the Piedmont and Coastal Plain physiographic provinces. The Fall Line represents the boundary on the surface where the edge of the wedge of sedimentary strata of the Coastal Plain meets the crystalline rocks of the Piedmont physiographic province. In the subsurface, the thickness of the sediments increases to the east and both the sedimentary strata and the igneous basement rock dip to the southeast (Figure 2). Approximate depth to the crystalline rock under the Fort Dix area is 1,000 ft (ICF Kaiser 1992).

The present penetrometer-based investigation was designed to locate shallow (60 ft or less depth) contamination in the soils and surficial geologic units. A geologic map of a portion of the Fort Dix area is presented in Figure 3. There are small areas underlain by the Quaternary Cape May,

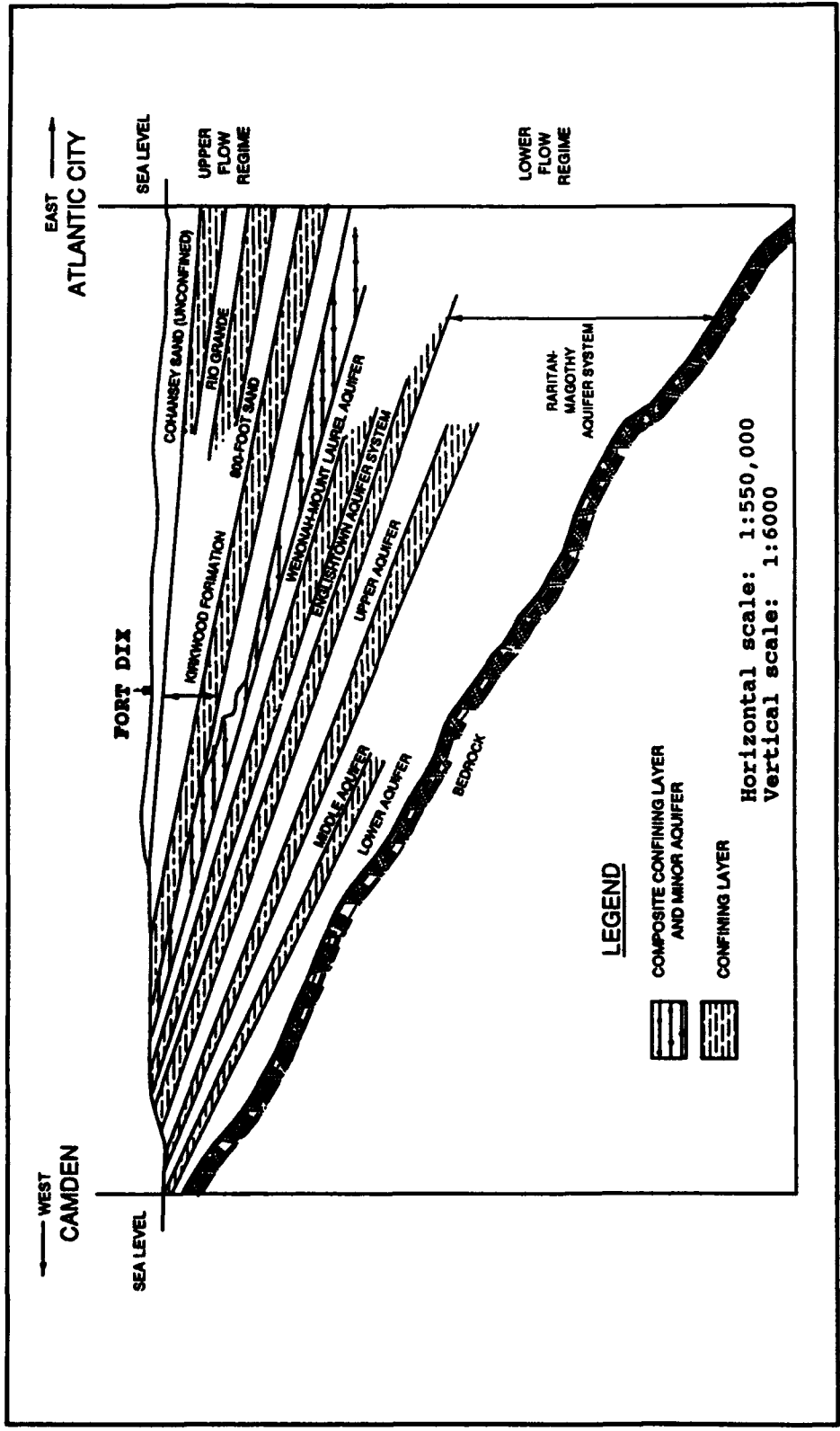

Figure 2. General geologic cross section of New Jersey (from ICF Kaiser 1992)

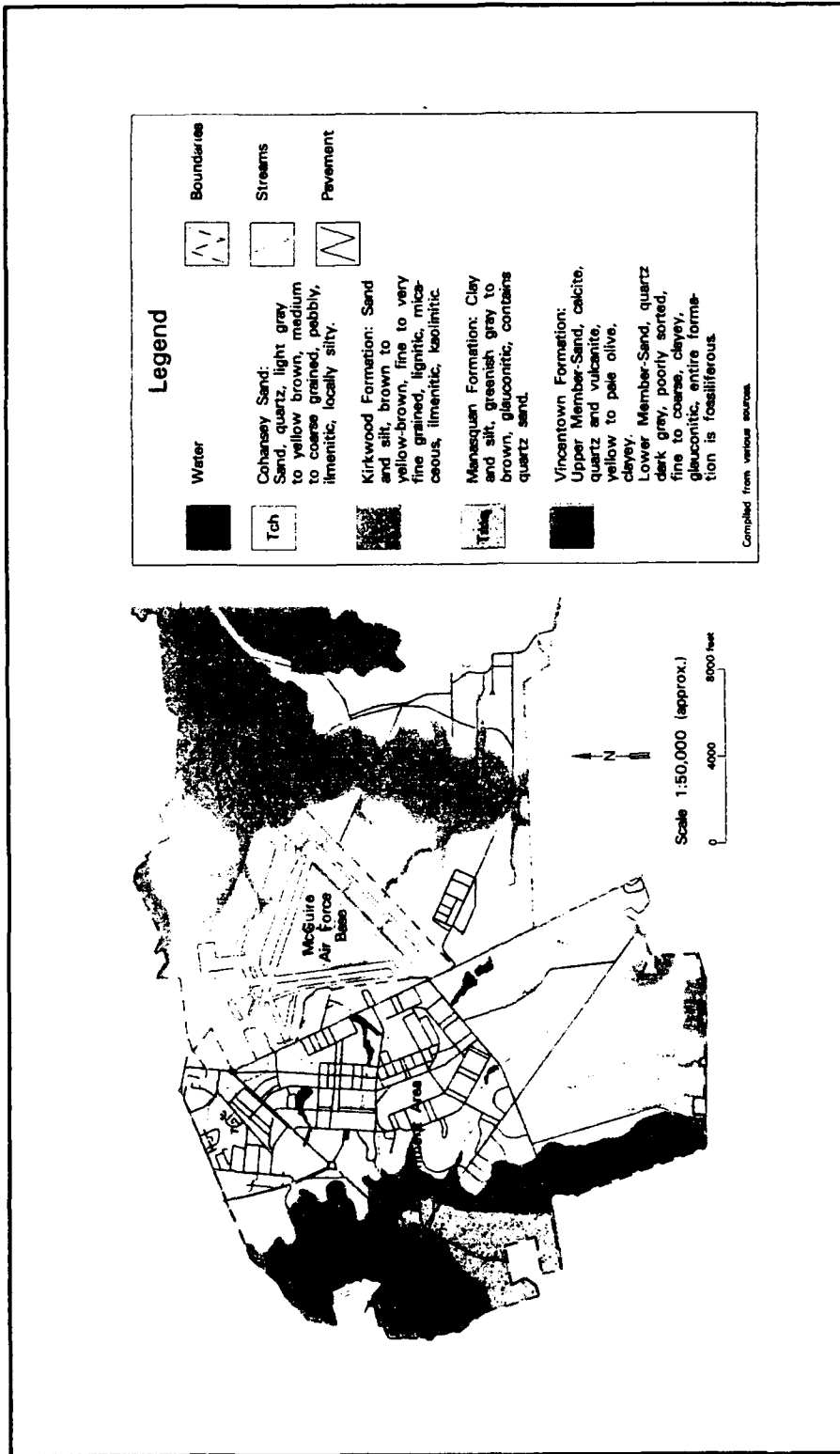

Figure 3. Geologic map of Fort Dix

Pensauken, and Bridgeton Formations (Pleistocene in age). These units are found only as thin patchy deposits capping some hills and stream divides. Most of the Fort Dix area is underlain by the unconsolidated Tertiary units including the Cohansey Sand (Miocene or Pliocene in age) and the Kirkwood Formation (Miocene in age). The Tertiary units generally strike 70° to 80° east and dip to the southeast at 10 to 20 ft/mile. Small areas to the extreme western end of the installation are underlain by the Manasquan Formation (Eocene in age) and the Vincentown Formation (Paleocene in age). A very small area in the center part of the northern boundary is underlain by the Manasquan Formation. Ninety percent of all the area of Fort Dix is underlain by the Cohansey Sand and the Kirkwood Formation. All of the areas studied in this investigation were underlain by the Cohansey Sand.

The Cohansey Sand is a medium-to-coarse grained, pebbly, unconsolidated quartz sand. The unit varies in color from light-grey to yellow-brown. The unit typically contains mica and ilmenite and may become locally clayey. The Cohansey Sand is classed as a deltaic sand deposit with thin, discontinuous sections of laminated clays. It can be up to 40 ft thick in this area and is highly permeable.

The Cohansey Sand is underlain by the Kirkwood Formation, a light grey-to-dark brown, fine-to-very fine-grained quartz sand and silt. The formation contains some mica, clay, and traces of lignitic material. The Kirkwood Formation is divided into two units—an upper unit composed of very light grey to light yellow orange, very fine to fine-grained sand and a lower unit that is a brownish-black, clayey-silt to very fine grained, micaceous quartz sand. The Kirkwood Formation can be from 20 to 100 ft thick in eastern New Jersey.

The Kirkwood Formation is underlain by the Manasquan Formation, a green, glauconitic marl with some quartz sand. The Manasquan Formation is approximately 40 ft (ranging from 10 to 175 ft) thick and overlies the Vincentown Formation a yellow-to-olive quartz, carbonate and glauconite-rich sand at the top and a dark grey, poorly sorted, glauconitic, fossiliferous quartz sand at the bottom. The Vincentown Formation is approximately 40 ft thick and overlies the Hornerstown Sand, a dark green clayey, glauconitic sand. The Hornerstown Sand is the lowest Tertiary unit and rests unconformably on the Cretaceous Redbank and Navasink Formations.

The Cretaceous formations at Fort Dix beginning with the youngest units are the Redbank and Navasink Formations and the Mt. Laurel Sand. These are all poorly sorted clayey sands with some glauconite. Underlying these units are the Wenonah Formation, the Englishtown Sand, the Woodbury Clay, and the Merchantville Clay; clayey-silt, quartz sand, and clay are present in all units. The lowermost Cretaceous unit is the Magothy-Raritan Formation which is a medium to coarse sand with interbedded clay units (Owens and Minard 1960).

Hydrogeology

There are two major aquifer systems under Fort Dix—the Kirkwood-Cohansey Aquifer and the Raritan-Magothy Aquifer. The upper flow regime includes the Cohansey and Kirkwood Formations and extends to approximately 50 ft below ground surface. The Raritan-Magothy Aquifer system is the lower regime of the two aquifer systems and is at least 300 ft below the surface at Fort Dix. The layers separating the upper and lower flow regimes consist of the Manasquan, Vincentown, Hornerstown, Red Bank, and Navesink Formations. These sedimentary units function as confining layers and separate the upper and lower aquifer systems. Only a small percentage of groundwater that infiltrates through the upper flow regime enters the deeper flow regime. Groundwater in the upper regime follows local flow lines from areas of infiltration discharges into local streams.

The Cohansey Sand and the underlying Kirkwood Formation act as one aquifer that is hydrologically continuous. This system functions as the phreatic aquifer at the site. The Cohansey Sand has a thickness that ranges from 18 to 40 ft. The coefficient of permeability of this unit ranges from 1.8×10^{-3} to 6.1×10^{-3} cm/s, and the transmissivity ranges from 1.1×10^{-3} to 7.3×10^{-3} ft²/s. The total thickness of the Kirkwood Formation ranges from 20 to 51 ft at the site, and its coefficient of permeability ranges from 2.76×10^{-4} to 9.91×10^{-4} cm/s. The transmissivity ranges from 1.28×10^{-3} to 5.19×10^{-4} ft²/s (Camp, Dresser, and McKee (CDM) 1986).

The area within Fort Dix is surface-drained by several perennial and intermittent tributaries of Crosswicks Creek and the North Branch of Rancocas Creek. Crosswicks Creek and Rancocas Creek both flow into the Delaware River. Total length of stream channels within the installation is estimated to be 54 miles. Many of the streams are bordered by wetland areas, indicating relatively shallow depths to groundwater. Several ponds and lakes are also present within the installation, ranging in surface area from one acre (General's Pond) to 40 acres (Brindle Lake) (ICF Kaiser 1992).

The Kirkwood-Cohansey Aquifer is an important water resource because while it furnishes only minor domestic well production, it is the source of the groundwater feeding into the local surface drainage. In the lowland areas at Fort Dix, water from the Kirkwood-Cohansey Aquifer feeds into Rancocas Creek and the Mullica and Bass Rivers. Additionally, there is some movement of groundwater through the Manasquan Formation into the coarse sands in the deeper Mt. Laurel and Wenonah Formations due to gradients produced by local water supply pumping. The groundwater under Fort Dix is classified as class I Pinelands, regulated by the New Jersey Pinelands Commission, as defined by the Pinelands Protection Act of 1979. The acceptable level of organic contamination (other than natural) in the groundwater is zero (ICF Kaiser 1992).

3 Investigation Equipment and Procedures

General

The field investigation conducted at Fort Dix used the Site Characterization and Analysis Penetrometer System (SCAPS). The SCAPS system incorporates surface geophysical methods, surveying and mapping methods, special penetrometers with sensors for contaminant detection, and subsurface sampling equipment to map soil characteristics and contaminant distribution.

The core of the SCAPS is a penetrometer unit mounted in a specially engineered 20-ton truck designed with protected work spaces to allow access to toxic and hazardous waste sites while minimizing exposure of the work crew inside (Figure 4). The penetrometer, in addition to providing classical geotechnical engineering information such as soil strength, is equipped with sensors that can measure other physical and chemical characteristics of the soil as the penetrometer tip is forced through the soil.

The SCAPS penetrometer includes discrete sensors that enable determination of soil classification and stratigraphy, soil electrical resistivity, and soil fluorescence spectral characteristics. The on-board data acquisition system permits real-time data collection and near real-time data processing and interpretation of sensor data as site screening proceeds. The database may then be combined with the site survey information for further analysis and interpretation, including three-dimensional visualization of soil characteristics and fluorescence intensity distribution. Discussions of the system capabilities and limitations are listed further in the body of this report.

Field Operations

In general, the following procedure was established for investigating each of the sites the SCAPS unit visited at Fort Dix. Each procedure is discussed in further detail in the body of this report; the following section provides an overview of the general methodology for field operations. The detailed description of the SCAPS components follow the Field Operations section; the

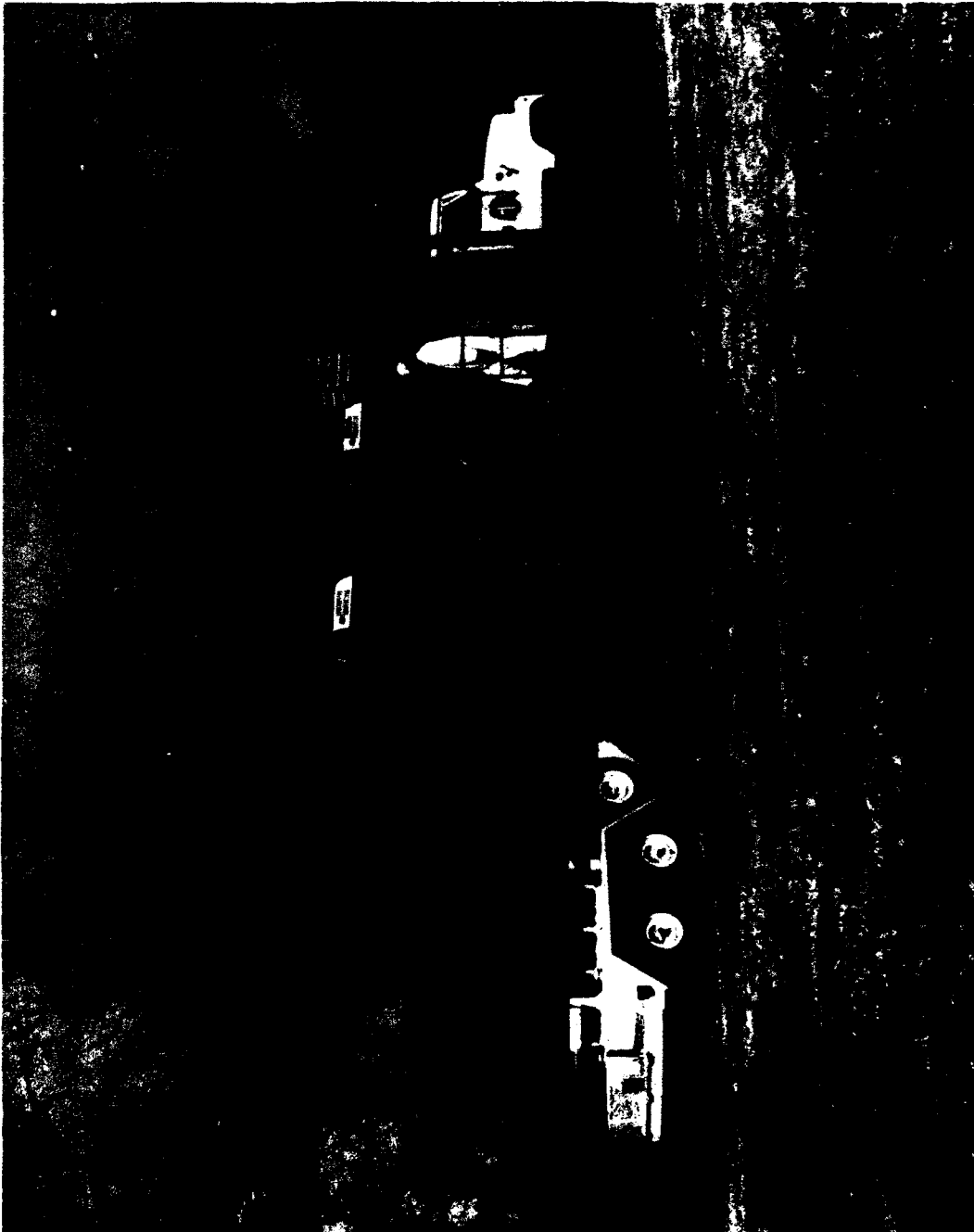

Figure 4. Photograph of the penetrometer truck and grouting trailer

description of the components also includes site-specific (Fort Dix) considerations as necessary.

A visual survey of each site was performed and an approximate location for each planned penetration was determined based on such factors as proximity to suspected POL contaminant sources, anticipated groundwater flow patterns, suspected underground obstacles, cultural features, topography variations, and mobility limitations.

A survey to locate underground utilities and underground obstacles was conducted at each site. This effort was necessary to prevent damage to the penetrometer, ensure crew safety, and to prevent damage to utilities. Many of the sites visited contained a variety of underground utilities such as telephone cables, gas lines, electrical power cables, water pipes, sanitary sewer lines, drainage pipes, and steam lines.

Calibration for the soil strength measurements were typically made when the probe was installed in the truck, prior to field work. Calibration procedures are detailed further in this report. Typically, no further calibration was required for soil strength transducers unless erratic readings were noted.

At the start of a soil penetration, the SCAPS truck was positioned over a push point location, and the laser fluorometry system was referenced to a fluorescence standard prior to penetration (described in a later section of this report). The cone penetrometer was then advanced into the soil at a rate of 2 cm/s. As the penetrometer advanced, the sensors collected soil strength and spectral information as a function of depth. The data acquisition system stored the raw data as the penetrometer advanced, and the data were partially processed and displayed on a computer monitor in real-time. At the required penetration depth, the penetrometer advance was halted, and preparations were begun to retract the penetrometer.

As the penetrometer was retracted, a hot water/steam-cleaning system was used to wash each rod section. Steam cleaning removed possible contamination from the rod. The decontamination cleaning water was collected in a steel drum for off-site disposal. A grout mixture was placed into the hole left by the penetrometer. The grout was used to seal the hole to prevent cross-contamination within the soil layers.

Upon completion of retraction, the laser fluorometry system was again referenced to the fluorescence standard. The Soil Classification Number (SCN) and fluorometry results were then plotted as a function of depth.

The truck was positioned over the next push point location and the above steps were repeated. The details describing the above procedures are detailed in a later section of this report. Decisions for subsequent push point locations were based on the factors mentioned above and on any perceived gradient in the data collected at the site. The contaminant concentration visualization data were later processed and plotted to produce a three-dimensional display of the plume for sites where fluorescence patterns were noted.

Buried Obstacle Detection

Each site contained buried utilities and underground obstacles. Utility maps were provided by the DPW, and limited utility tracing was performed by the Public Utility (Gas) Company, but the requirement to detect, locate, and avoid underground utilities was largely a SCAPS crew responsibility. Two methods of buried utility and obstacle detection were employed at Fort Dix. These methods usually complemented each other. The first method utilized electromagnetic induction with a Geonics EM-31™ Terrain Conductivity Meter (Geonics, Ltd., Mississauga, Ontario), and the second method used electromagnetic detection with a Radiodetection RD400™ Pipe and Cable Locator (Radiodetection Corp., Mahwah, New Jersey).

The Geonics EM-31™ instrument uses the in-phase component of an induced electromagnetic field produced by a transmitter coil energized with an alternating current. A receiver coil senses the generated magnetic field. The instrument is approximately 12 ft long and is most useful in detecting large metallic objects. It can detect a 55-gal metal drum at a depth of approximately 12 ft. The instrument displays a weighted average of the earth's conductivity as a function of depth. The instrument is influenced by above-ground objects such as metal buildings and fences, and overhead power lines. Its use was limited to areas without such above-ground features. The instrument does not have sufficient resolution to accurately locate small buried objects and small utility lines.

The Radiodetection RD400™ instrument consists of two units; a receiver that detects the magnetic field resulting from an electric current flow on a buried cable or pipe, and a transmitter that emits either an 8 or 33kHz radio signal that can be coupled to the cable or pipe. Four different types of current flow (signals) may be located—(a) a power signal radiated from electric power cables; (b) a radio signal originating from distant very low frequency radio transmitters, which penetrates soil and is reradiated by buried lines; (c) an 8kHz signal applied to a buried line by the RD400™ transmitter (a separate unit); (d) a 33kHz signal applied to a buried line by the RD400™ transmitter. The Radiodetection RD400™ was used exclusively to track buried utilities because the major areas of investigation were cluttered with structures, fences and power lines that made the Geonics EM-31™ behave erratically.

Site Mapping Techniques

The location of penetrometer push points is normally accomplished using a total station electronic distance measuring system (EDM) that is designed to be accurate to within 0.05 ft per mile (10 cm per km). The site mapping work at Fort Dix was done with an EDM unit equipped with an electronic notebook to permit data transfer to the microcomputers in the SCAPS truck.

Established survey monuments within Fort Dix served as control points for determining penetrometer push point coordinates and elevations. Closed-traverse surveying ensured point location accuracy. All coordinates given in this report are referenced to the New Jersey State Plane (Transverse Mercator) Coordinate System. Site maps used in this report were generated at the WES by computer digitizing selected Fort Dix site construction blueprints and overlaying cultural features, updated building information, and penetrometer push point coordinates.

Soil Classification

Soil classification methods are discussed in this section. A sectional view of a penetrometer equipped to measure soil strength and fluorescence spectral characteristics is shown in Figure 5. The point load cell is loaded in compression as the cone tip is advanced. The friction sleeve load cell is in the form of a hollow cylinder that is strain gauged on its outer surface, and measures frictional force developed on a freely sliding outer sleeve positioned just behind the conical tip element. The cell surrounds the tip load cell and is also loaded in compression when soil friction acts on the friction sleeve which forms the distal end of the probe. The design employed in this soil strength unit allows the tip penetration resistance and sleeve friction to be measured independently and continuously.

Two calibration procedures were used with the cone employed in this investigation so that separate calibration curves could be developed for the two load cells. The point resistance load cell was calibrated by cycling the load from zero load to approximately 16,000 psi and back to zero load several times. The cell was then loaded to selected load increments and back to zero. The load cell output was read for each load increment applied. The zero load conditions at the beginning and end of each loading increment were noted and care was taken to see that the unit returned to zero. The load increments were increased until the compressive force reached the maximum capacity of the cell. The friction sleeve load cell was calibrated in a similar way. Figure 6 shows typical calibration curves obtained for a strain-gaged penetrometer instrument. Each load cell was calibrated independently, but the output of each cell was measured as the calibration proceeded so that any influence of one cell on the output of the other could be determined. Typically neither cell showed any influence on the other. Calibrations typically have a high degree of repeatability; test responses were generally within 0.5 percent of the previous test responses.

Techniques for using the soil strength measurements (cone tip and sleeve friction) made with the cone penetrometer to determine soil type have been well-documented (Campanella and Robertson 1982, Olsen and Farr 1986, Olsen 1988). The classification scheme used by the SCAPS system was devised by Olsen (1988) to identify the types of soils penetrated. The chart used in the soil classification scheme is shown in Figure 7. The basic premise is that soil types can be identified by the combinations of corrected values of

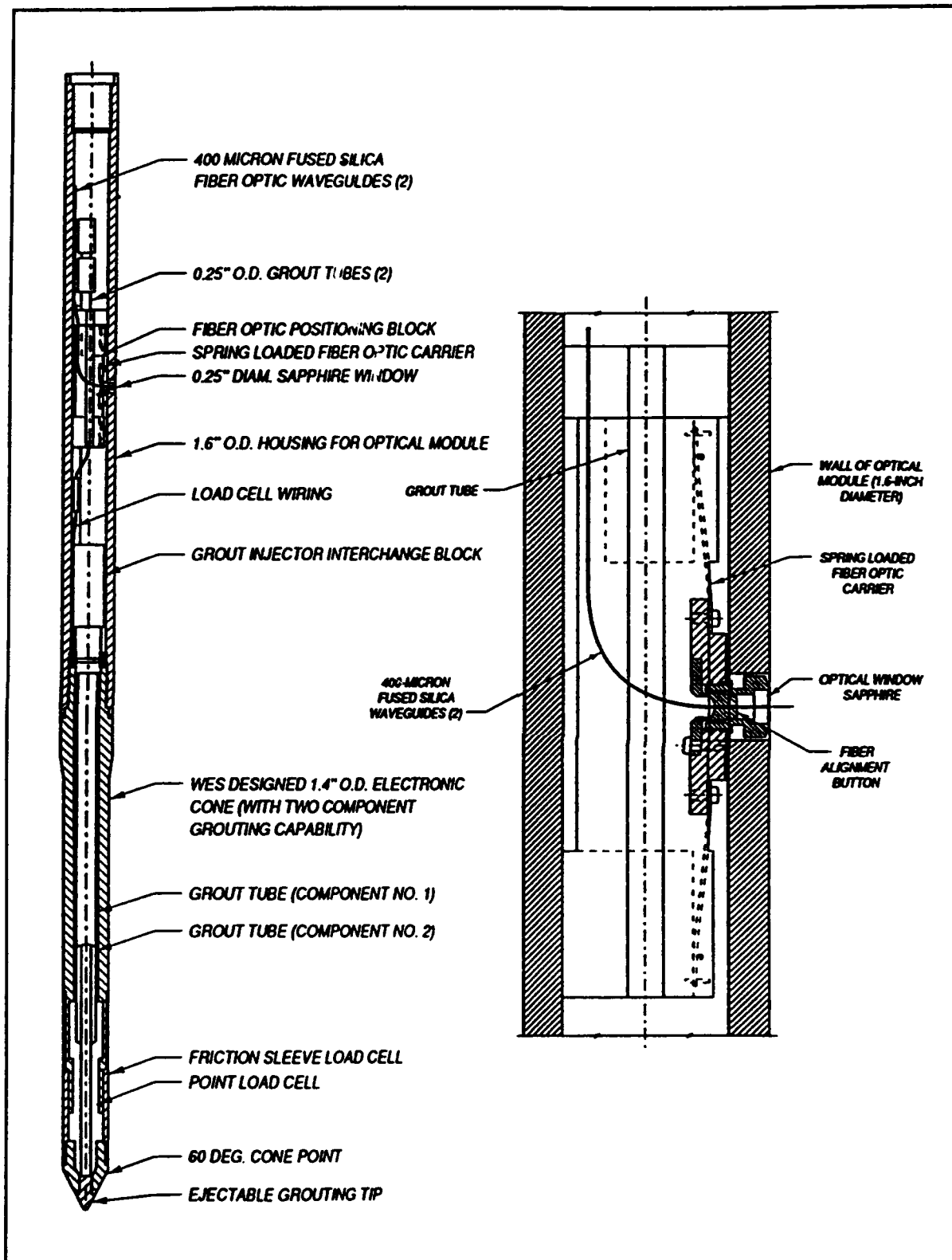

Figure 5. Sectional view of penetrometer equipped to measure soil strength

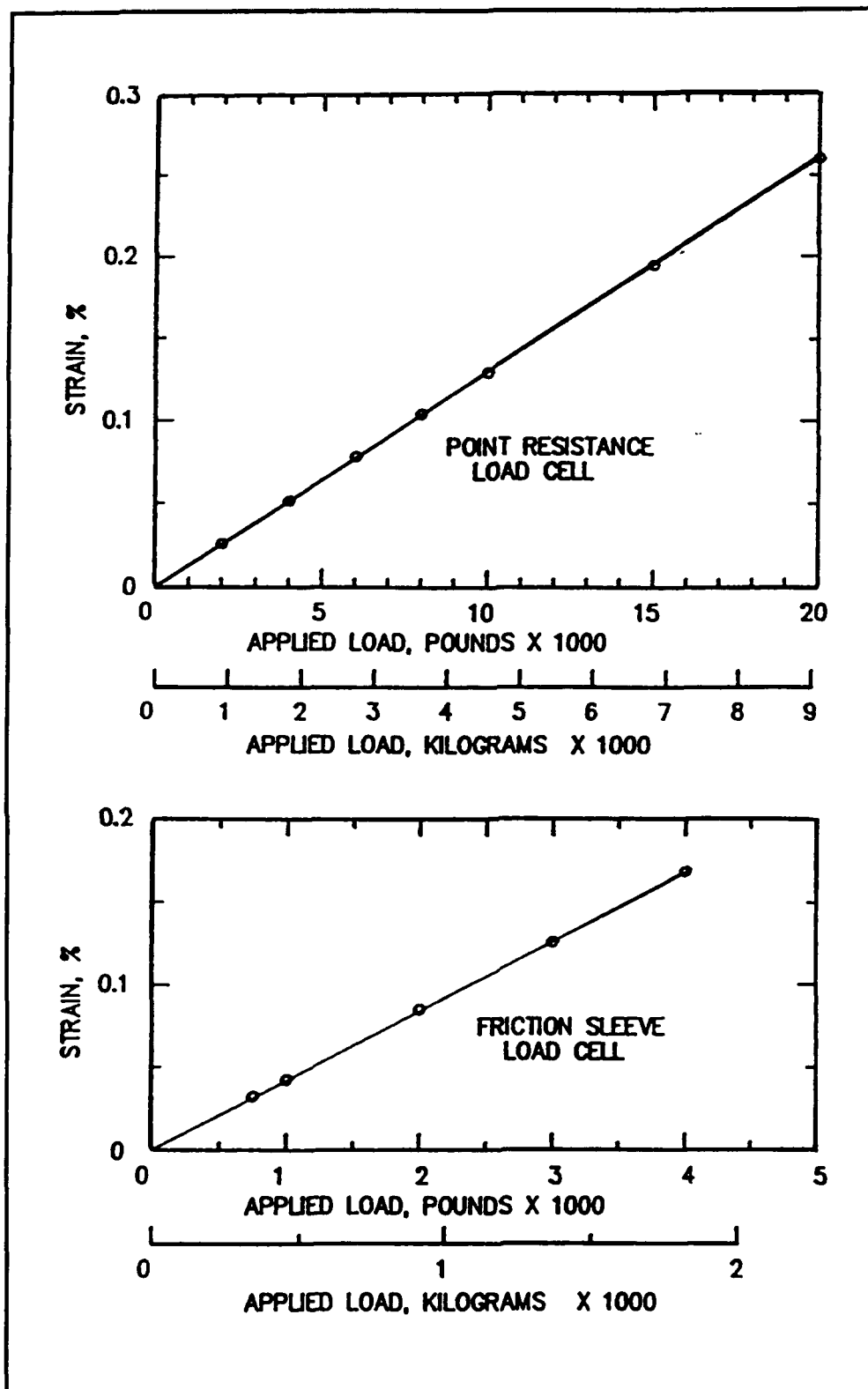

Figure 6. Calibration curve for the strain-gauged penetrometer cone and friction sleeve

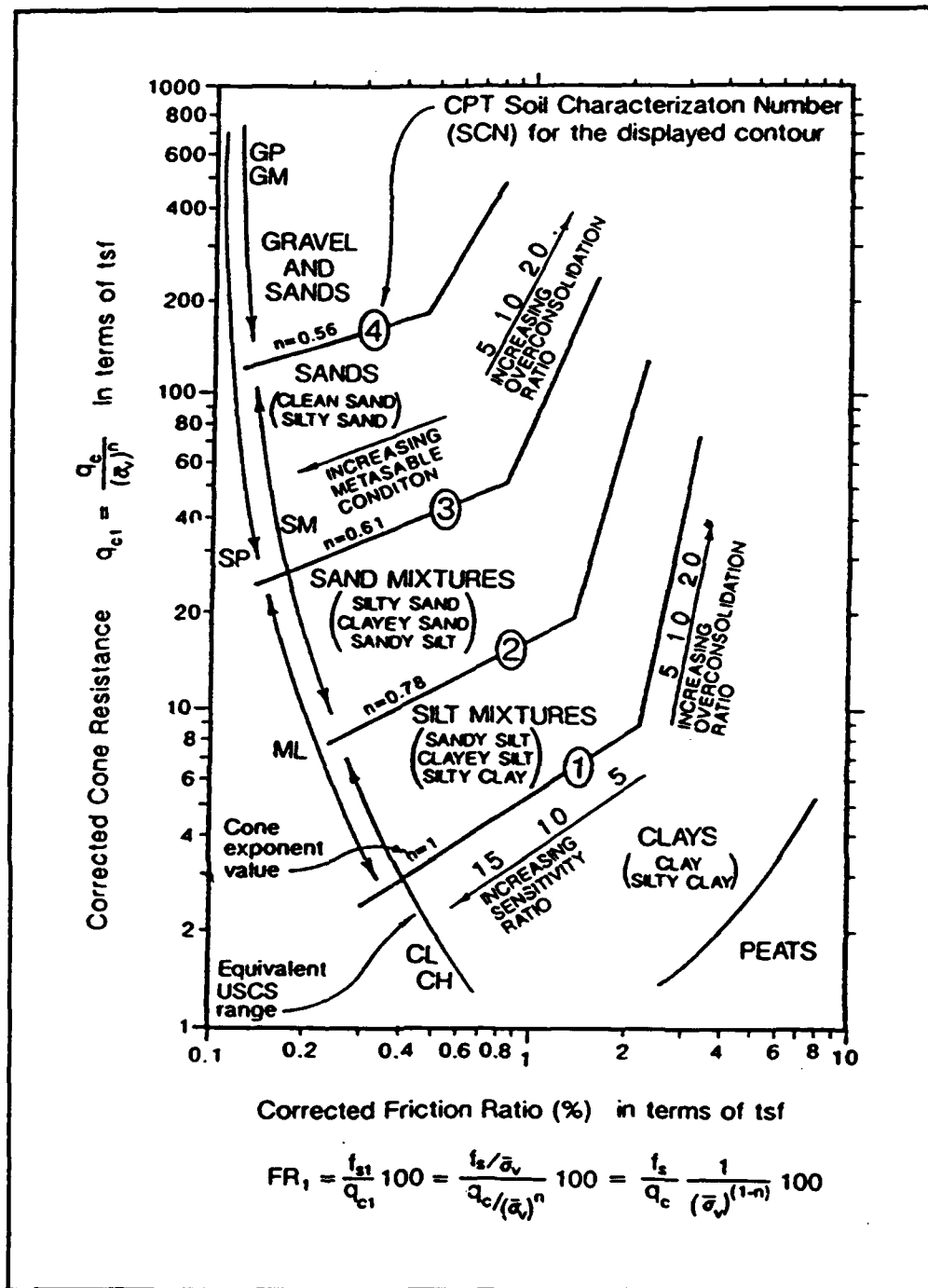

Figure 7. Soil classification chart based on values of cone resistance and sleeve friction (from Olsen 1988)

sleeve friction and point bearing resistance, f_{s1} and q_{c1} . The corrected parameters are the results of adjustments made to the measured values of sleeve friction and cone resistance, f_s and q_c . These adjustments correct the measured values to overburden stress conditions of 1 ton/ft². The output of the computer algorithm for mapping the strength parameters onto the soil classification chart is an SCN which correlates to basic soil types. An SCN of 0.5

corresponds to a typical clay, the range of SCN's from 1 to 2 represents silt mixtures, SCN's for sands range from 2 to 4, and a fine sand has an SCN between 2.5 and 3.5.

Soil Fluorescence Measurements

General procedures

The fluorometer was adapted from a design developed by Lieberman, Inman, and Theriault (1989) for use in measuring POL fluorescence in seawater. A patent was issued to the U.S. Army for an in situ spectral investigation system designed into a cone penetrometer package (U.S. Patent Office 1992). A schematic of the in situ fluorometer cone penetrometer system is presented in Figure 8. To make a measurement, the exciting radiation was produced by firing a pulsed nitrogen laser (emitting at 337-nm wavelength). The laser light was coupled into two fibers: a timing circuit fiber and the downhole irradiation fiber. The light in the timing circuit fiber was used to trigger detection circuitry and assure optimum capture of fluorescence energy. The major part of the laser pulse was directed into a 400-micron optical fiber that passed down the center of the penetrometer rod. The fiber terminated at a 6.35-mm diam sapphire window that passed the light onto the soil surface adjacent to the window. The fluorescence signal was returned by a 400-micron fiber and was carried back up through the penetrometer rod to the polychromator. In the polychromator, the fluorescent energy was dispersed and the energy distribution at the wavelengths of interest was measured using a linear photodiode array. Readout of an entire emission spectrum (1,024 measurements) required only 15 msec. The rapidity of the readout made it practical to "stack" or add successive pulses and increase the sensitivity of the unit.

Each fluorescence spectrum consisted of photon counts measured at 1,024 points (over a wavelength range of 300 to 800 nm) for every 0.2-ft layer of soil investigated. The present data processing system records all spectral intensity measurements and makes corrections for instrument drift during measurement. The corrected data were screened to develop the photon counts for the spectral band of interest and the background.

The response of the fluorometer is usually directly related to the concentration of aromatic (ring) compounds in the soil. Fluorescence of any aromatic compounds with basic or acid functional groups is usually pH dependent. Ionized aromatic compounds will fluoresce at different wavelengths and at different intensities from the same compounds in a nonionized state. Fluorescing compounds adsorbed on solid surfaces will typically fluoresce with greater intensity than the same compounds in solution (Murphy and Hostetler 1989). Decomposition or weathering phenomena also change the fluorescence of hydrocarbons. Generally, the aromatic compounds that fluoresce are concentrated in the weathering process because the lighter hydrocarbons volatilize and the longer straight-chain hydrocarbons are more easily decomposed by microbial activity. The number of interfering variables and uncertainties

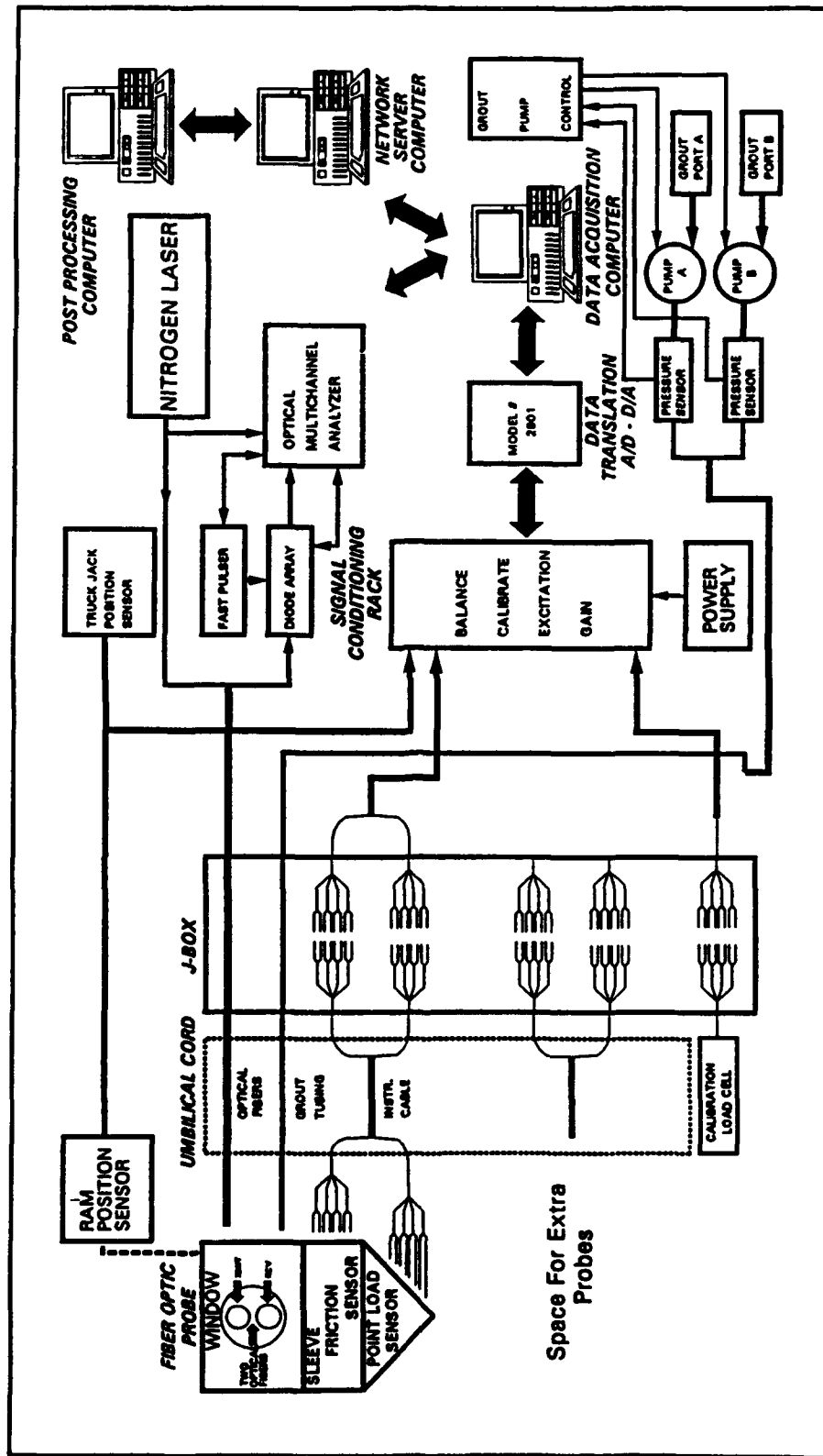

Figure 8. Schematic of cone penetrometer system showing the in situ fluorometer and the soil strength measuring system

concerning the composition of the hydrocarbon residues present restrict the fluorometer measurements to use as a qualitative and semi-quantitative indicator of the presence of hydrocarbons and POL contamination in the soil. Fluorescence from certain minerals and other chemicals (dyes) may interfere with the fluorometer response and potentially mask the presence of hydrocarbon contamination.

Site-specific considerations

The fluorometer built into the cone penetrometer is designed to be a screening tool that will allow the detection of POL products that typically contain fluorescent compounds or fluorophores. The typical fluorophores in petroleum products are multi-ring hydrocarbon compounds (polynuclear aromatic compounds or PAH's) that have delocalized electrons and will interact with UV photons to emit light at a longer wavelength than the wavelength of UV excitation. With the UV-source used in the SCAPS fluorometer system (an N₂ laser) the excitation wavelength (337 nm) can excite fluorescence in some of the modified 2-ring aromatic hydrocarbon compounds (naphthalenes), the 3-ring (anthracenes), 4-ring (naphthalenes), and heavier compounds. Generally, more than one fluorescent hydrocarbon can be expected to be present in weathered petroleum products, such as POL wastes in soil. Pure petroleum products have relatively distinct fluorescence peaks that mixtures of products and weathered products lack. The fluorescent response from mixtures tends to become featureless mound-shaped spectra with poor definition of peaks from individual components. The broad spectra make quantitative interpretation of the data difficult in that the wavelength of the maximum fluorescence can change with minor changes in the composition of the residual hydrocarbons. A further complication arises due to the effects of the soil matrix on the fluorescence. The same hydrocarbon mixture may fluoresce with different intensities in different types of soils (Apitz et al 1992). The most straightforward approach to estimating the amount of hydrocarbon in the soil is to develop standards from clean and POL-contaminated soil obtained from the site being studied. Typical silty sand soil was obtained from an excavation at the Sewage Treatment Plant construction site and was used as a background sample. The sample was analyzed for total recoverable petroleum hydrocarbon (TRPH) using the standard EPA method (SW-846 Third Edition). TRPH concentration was less than 25 ppm (sample 26116).

Contaminated soil from one of the Fort Dix sites (4400 Area Motor Pool) was similarly analyzed and the contaminated soil was mixed thoroughly with the uncontaminated sand to form samples with intermediate levels of contamination. Two contaminated samples (31391 and 31392) were used to form separate calibration curves for comparison. Sample 31391 contained an oil and grease concentration of 460 ppm and 430 ppm TRPH. Sample 31392 contained an oil and grease concentration of 8200 ppm and 7900 ppm TRPH. The maximum fluorescence levels (in counts) averaged for three samples of each mixed soil, were plotted against the calculated TRPH concentration of the samples to form a calibration table. A curve was prepared for each sample by using least squares procedure to fit a line to the data points (Figure 9).

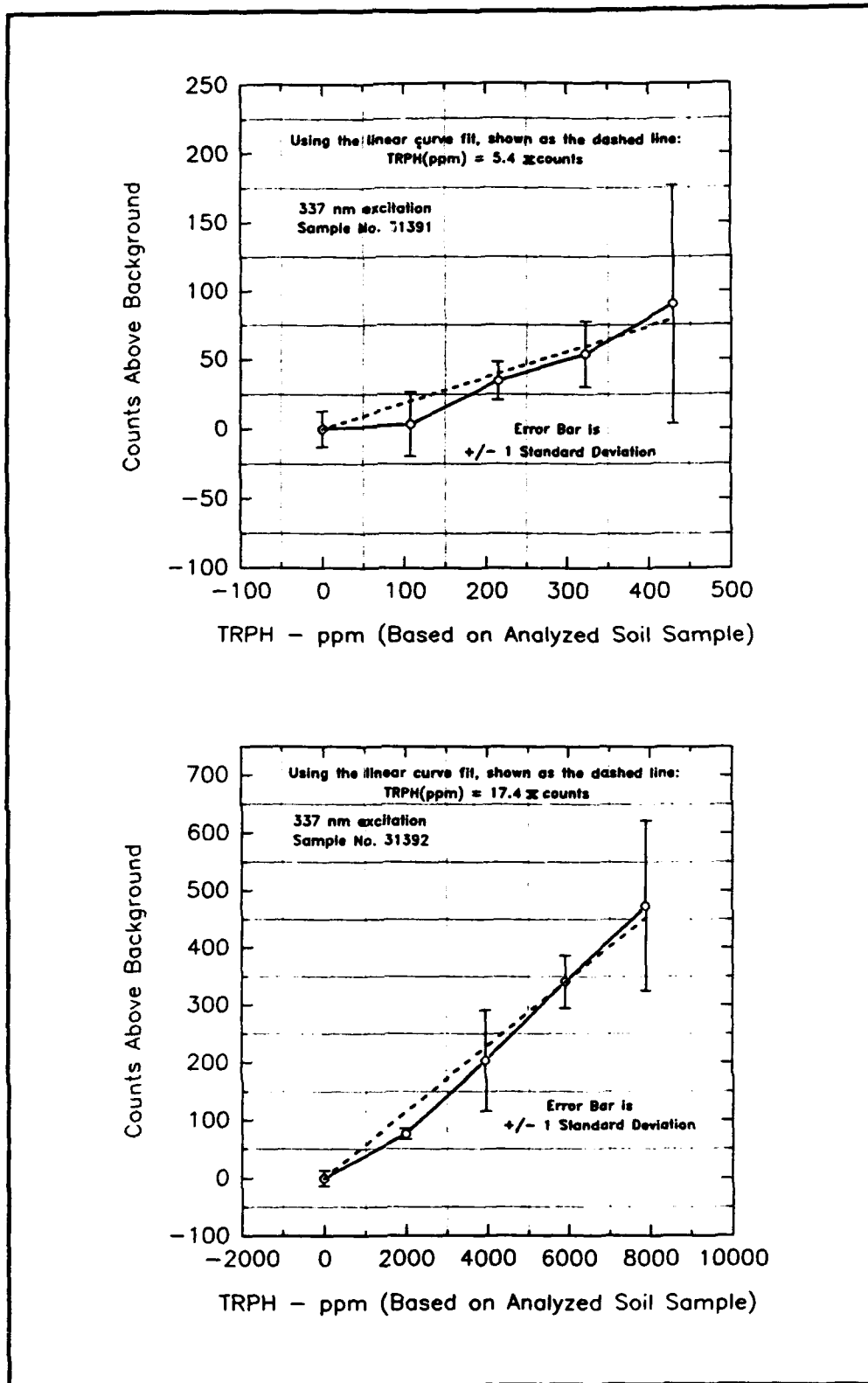

Figure 9. Calibration curves for fluorometer based on fuel oil in local sand

The curve allows a predicted TRPH value to be associated with each maximum fluorescence intensity observed in the soil at this site. While UV-excited fluorescence is the major signal observed in the fluorometer, there is always some light scattering that produces light with a range of frequencies. The background correction for the current investigation was made by measuring the spectrum generated by irradiating the sample of Fort Dix sand that showed a laboratory TRPH level below the detection limit (<25 ppm for soils and 2.2 - 2.7 ppm for water) when analyzed using standard EPA protocols. A sample of this soil was irradiated at the start of each penetrometer push or calibration run to obtain a background correction for the fluorometer. The background measurement also served as an equipment check.

Complications may arise in applying a specific calibration curve because the wavelength of maximum fluorescence may vary with the hydrocarbon contaminant being observed. The usual approach involves picking the maximum fluorescence intensity over a specified interval (or window) in the fluorescence spectrum. If the wavelength of maximum fluorescence moves outside the window the estimated value obtained for a specific number of counts is considered less reliable. If the soil type changes, the same amount of hydrocarbon may also produce a stronger or weaker fluorescence. Soil strength measurements made with the penetrometer provide data on the soil type present and allow the validity of the TRPH estimate to be assessed for each soil layer.

Verification of the in situ fluorometer response was accomplished by retrieving soil and groundwater samples for laboratory analysis. The samples were retrieved utilizing the methodologies described hereinafter. The samples were taken approximately 2 ft horizontally adjacent to the penetrometer holes from which fluorescence data were acquired.

A robust samples retrieval program for detailed verification purposes was not pursued. Initial sampling efforts were designed to provide a means of determining the contaminant concentration at relatively higher in situ fluorescent soil layers instead of for the sole purpose of verifying fluorometer accuracy and resolution. Samples were retrieved from those sites where consistent in situ fluorometer response patterns were observed (the Bivouac Area 5 Washrack, the Fire Tank Training Area, the 4400 Area Motor Pool, the 5426 Boiler Plant, the 5800 Area Motor Pool, and the 5881 Boiler Plant Area). The site-specific sampling analyses with comparisons to in situ fluorometer response are tabulated further in this report. The description of the sampling equipment is also contained further in this report.

The soil samples shown in Figure 10 were recovered from the 4400 Area from a depth of approximately 8 ft (note the light and dark mottling of the soil indicating non-uniform distribution of the waste oil). The samples reflect the conditions in the ground where the fluorometer responds to the fine-detail variation in POL concentration. When a sample is recovered for analysis it will typically be partially mixed and a sample will be extracted for analysis. Any attempt to compare the in situ fluorometer response with the analytical results from the laboratory is subject to the problem that the laboratory



Figure 10. Photograph of a heterogeneously contaminated soil sample

analyses represent an average concentration that may not exist in situ. Further, the sample cannot be taken at the exact location where fluorometer readings are made as it is impossible to obtain the soil samples from an open probe hole with current sampling devices; the soil sampling penetration must be positioned adjacent to the previous hole. When the contamination is as non-uniformly distributed as in the soil at Fort Dix, the calibration curves (no

matter how carefully prepared) can only provide an order-of-magnitude estimate of what values the analytical laboratory might be able to obtain. Such apparent mismatches between in situ soil fluorometer response, retrieved soil sample fluorometer response, and analyzed sample results are a function of the heterogeneous nature of soil contamination patterns observed at Fort Dix. The calibration curves are also affected by this phenomenon. Theoretically, the slopes of the two curves should be identical (a change in counts is directly proportional to the change in TRPH concentration, all other variables being constant). The upper curve (taken from sample 31391) has a slope that is significantly steeper than the bottom curves. A likely reason is due to the heterogeneous nature of the soil, i.e. the two soil samples contain different contaminant concentrations (other than TRPH) eliciting different fluorometer responses. The upper curve (from sample 31391) would have a steeper slope due to higher concentrations of fluorophores.

Fluorometer response may vary as the temperature of the equipment (especially the photodiode array) changes through the working period. In order to track any changes and to make any corrections for instrument drift, fluorescence measurements are made on a standard 10-micromolar solution of rhodamine 6G in ethanol and water. Fluorometer system response (normalized counts) is obtained at the beginning and end of each penetrometer push and any drift that occurred is assumed to have occurred uniformly over the depth of push. The drift correction is calculated as a linear change with depth and is added to or subtracted from the measured intensity.

At most sites where the SCAPS fluorometer sensor was employed, prior investigations or environmental records have indicated POL contamination from fluorometrically detectable materials were present. At Fort Dix many of the sites have been utilized since World War I, and specific POL contamination with known spectral properties had not been identified prior to deploying the fluorometer. The fluorometer was also deployed at problematic areas where a generally unknown POL product might be present. Every soil layer that showed fluorescence, regardless of the signature (intensity pattern and wavelength), was investigated. Fluorescence that is not related to POL contamination may occur, due either to fluorescent dyes and brighteners added to common consumer products or natural mineral fluorescence. For example, septic tank effluent has been shown to fluoresce because optical brighteners are added to laundry detergent and other cleaning products. Fluorescence in some types of minerals is so pronounced that UV-lamps are routinely used in prospecting (Dake 1953). When in situ fluorescence was observed in the present study and some of the retrieved samples showed no cursory visual evidence of POL, the spectral signatures were reviewed and the sample was examined to determine what component of the moist soil (fluid or solid phases) produced the fluorescent signal. The sample was then subjected to a laboratory analytical approach to identify the fluorescent compound or compounds.

Samples that fluoresced significantly but showed no POL (TRPH) contamination (in laboratory analysis) were recovered from the soil at two locations at Fort Dix. Samples of both water and soil from the east side of the 4400 Area

near penetration 1130-05 showed a spectrum with a broad peak centered at 440 nm. Both the water and sediment samples fluoresced. Laboratory analysis for POL showed the POL contamination was below detectable limit (<25 ppm) for the method used but the analysis of the groundwater did show elevated total organic carbon relative to other samples. A sample of an ethylene glycol-based deicing solution used on aircraft and runways at McGuire AFB and the Fort Dix Army Airfield was also obtained. An examination of the deicer showed very strong fluorescence from a dye that is added to the deicer in order to allow the area on the aircraft or pavement that has been treated to be tracked by the personnel operating the deicing sprayer. Thousands of gallons of deicer are applied to the aircraft and pavements during a typical winter. It is suspected that some of the fluorescence observed in the 4400 Area is from deicer solution that has infiltrated the soil. The presence of deicer may account for the relatively high fluorescence observed in some samples that showed low TRPH levels but high TOC levels when analyzed. Discussion of this phenomenon is detailed in the 4400 Area Motor Pool Results and Discussion section. Samples were analyzed for analytes other than TRPH (including PAH, TOC, and oil and grease) for the purpose of determining which analyte was most responsible for the fluorescent signature observed.

A second series of samples that fluoresced but showed no significant POL contamination was obtained from the 5880 Area and 5881 Area. At these sites the fluorometer encountered a layer of gravel that contained fluorescing minerals. Small pebbles and granules of quartzite were recovered in soil samples taken at the fluorescing horizon. The examination of individual granules using the fluorometer indicated the granules themselves were the source of the fluorescence. The samples were subsequently identified as the mineral quartz in quartzite rock. Further details are presented in the discussion of the investigation of 5880 and 5881 Areas.

Data Acquisition and Processing

The SCAPS data acquisition system and the postprocessing system each have a separate control computer. The two computers are linked by a network so that data can be exchanged after the penetration testing. The data acquisition computer controls all systems and stores the data on a hard disk during the penetration test. The major block of spectral data is generated by the soil fluorometer system in the optical multichannel analyzer (OMA) and is written to the hard disk in binary format. The OMA is a separate computer that is controlled by the data acquisition computer through a general purpose interface bus (GPIB). The data acquisition computer is also interfaced directly with the amplifier/filter components for the measurement of strain on the cone tip and sleeve; amplifiers for the electrical resistivity measurements, total ram force, tip temperature; a variable potentiometer that reads out the position of the hydraulic rams (data used to calculate the depth of the penetrometer tip); and the computer network.

Cone tip resistance, sleeve friction, soil classification number, peak counts, and wavelength of peak counts were displayed in "real time" as a function of penetration depth on the data acquisition computer monitor screen. Cone tip temperature and total ram force were also monitored during penetration. All parameters except the optical data were stored on the hard disk in ASCII format. Each ASCII file also contained a header with x, y, and z coordinates and other site-specific information, including operator's notes.

The postprocessing computer was used to merge, calibrate, and format the data. Two-dimensional plots showing cone tip resistance, sleeve friction, soil classification number, fluorescence intensity, calibrated contaminant concentration, and wavelength of peak intensity as a function of elevation were generated after each penetration.

The data were transferred offsite (typically back to WES) and the post-processing procedure was repeated on a Silicon Graphics™ workstation. The procedure was modified to output the data in a format acceptable for three-dimensional interpretation and visualization of the data. The Silicon Graphics™ workstation will eventually replace the postprocessing computer in the SCAPS truck.

Penetrometer fluorometer data were interpreted using three-dimensional visualization software (Geologic Modeling Program, GMP and Interactive Surface Modeling, ISM) developed by Dynamic Graphics, Inc. (Alameda, California). All calculations were performed on a Silicon Graphics Indigo (Silicon Graphics, Inc., Mountain View, California). The GMP software accepts a single scattered data file in ASCII format and calculates a set of regularly spaced values (a grid) from the irregularly spaced data using the minimum curvature method (Briggs 1974). A calculated value in the grid may be very close in value to the corresponding point in the original data set but may not be exact. To accurately represent the data, the GMP software provides two tuning parameters; the vertical influence factor and the grid size. These parameters strongly influence the three-dimensional representation of the data, and proper selection of these parameters is a matter of judgment, and depends on knowledge of both the geology of the site and the spatial distribution of the data. The vertical influence factor is adjusted to enhance the lateral or vertical continuity of the site, and the grid size is chosen to approach as closely as possible the spatial distribution of the data. Lateral and vertical boundaries are also introduced to restrict the interpolations to physical limits of the data. The accuracy of each three-dimensional representation is checked by comparing the standard deviations of the residuals of many trial grids calculated for the site data. The grid that developed data that more closely approached all observed values is used in the visualization.

A completed three-dimensional visualization model was generated for the Fire Tank Training Area and the 4400 Area Motor Pool and is presented as a series of surfaces that represent specific values of the variable under study. The plots generated in this report represent the variable fluorescence intensities. The plot of the surfaces can be presented as a series of drawings of the site or as a computer-generated video tape that shows the soil volume with the

data boundaries presented in different colors. The GMP software can rotate the shape so that the volume of soil contaminated to the level specified can be observed from all sides. Subprograms are available that allow the volume model to be sliced at various points so that the variation of the contaminant concentration can be observed inside the projected volume.

Probe Decontamination Method

The penetrometer push rods pass through potentially contaminated soil layers as they were moved in and out of the soil. The push rods are decontaminated as they are retracted into the truck to prevent possible contamination of the rod handling area and minimize exposure of the operators.

The push rods were decontaminated using a truck-mounted pressure cleaning system. An enclosed housing through which the push rods travel is located under the hydraulic rams, between the truck floor and the ground surface below. Perforated rubber discs form a watertight seal around the push rods at the top and bottom of this housing. Injection ports attached to the housing spray pressurized hot water onto the push rods as they are retracted. The hot water or steam (up to 212° F) is pumped from an on-board kerosene-fired, hot-water pressure washer. The spent wash water is collected in the rod cleaning housing and drawn into a drum for disposal.

Grouting Method

The SCAPS unit is equipped to seal the penetrometer holes with grout either during or after push rod retraction. An on-board ChemGrout™ (LaGrange Park, Illinois) progressive cavity grout pump is used for pumping a grout mixture through either the tip of the push rod system or through a tremie tube; both procedures were used interchangeably at Fort Dix to demonstrate the efficiency and effectiveness of each method. Pumping through the tip was the method used at most sites.

The grout pumping system uses a hydraulic power supply to turn a progressive cavity rotor which can deliver up to 300-psi grouting pressure. An attached 5-gal hopper supplies the grout to the pump. A reducer manifold on the pump allows delivery through either a 1/4-in.-diam grout tube or a 3/8-in.-diam rout tube.

The grout used at Fort Dix consisted of a mixture of water and microfine, blended Portland cement (Lehigh Geocem™, Leeds, Alabama). The grout is a suspension of a uniformly produced cement clinker interground with high quality limestone, to produce a highly pumpable mixture. The grouting mix used at Fort Dix consisted of equal volumes of potable water and cement, mixed thoroughly prior to being pumped in to seal the penetrometer hole. In WES laboratory tests the permeability (hydraulic conductivity) of test

specimens mixed to a 1:1 ratio averaged 1.2×10^{-5} cm/sec. Using the 1:1 ratio mix allowed for adequate hole plugging in soil types ranging from sands to silts. The 1:1 mix produced a grout plug that was less permeable in all cases than the surrounding sand and silts of the Kirkwood-Cohansey Formations which have hydraulic conductivities ranging from 1.8×10^{-3} to 9.9×10^{-4} cm/sec. (CDM 1986).

Sampling Method

Soil and groundwater samplings were performed to allow comparison of field fluorometry results with analytical laboratory results. Soil or groundwater samples or both were collected at the Fire Tank Training Area, the 4400 Motor Pool Area, the Bivouac Area 5, the Post Laundry Building 5326, and the 5800 Area Motor Pool. Soil sampling was done using a Hogentogler™ bayonet-type sampler (Hogentogler Corp., Columbia, Maryland). The closed sampler was pushed to the depth where the top of the sample was to be located. The penetrometer rod was retracted to open the sampler and lock the open tube in position on the penetrometer rod. The rod was then advanced 10 cm into the soil so that a soil sample was forced up into the tube. The sample was recovered by retracting the rod to the surface. The soil sample was removed by opening the end of the sampler and pulling out the sample liner that enclosed the soil sample. The sample was then extruded into a new, precleaned glass sample jar. The samples were shipped under refrigeration (32°F) to the WES analytical laboratory.

Three borings with a hand-held soil sampling auger were accomplished at the 4400 Area Motor Pool site. Soil samples were retrieved from shallow depths (approximately 10 ft or less) using this manually-operated sampler. The augered samples were taken from discrete soil layers observed as having elevated fluorometer responses during adjacent (approximately 2-ft distance) penetrations. The auger sampling method was used in addition to the penetrometer soil sampler in order to obtain larger soil samples having a higher probability of containing the fluorescent material observed during the adjacent penetration. The auger sampler was thoroughly cleaned after each sample was retrieved in order to prevent cross-contamination between samples.

A Hydropunch™ Sampler (QED, Inc., Ann Arbor, Michigan) was used for collecting water samples. The sampler was driven to a predetermined depth below the water table and the sampler was retracted 26 cm to expose a screened opening. The positive groundwater head forced a sample into the sampler reservoir. No pumping or suction was used to obtain a water sample. The Hydropunch™ Sampler must be at least 5 ft below the water table in order to take a sample. While care was taken to try to place the screen within the strata from which a sample was desired, the sample can represent a composite of all of the water above the screen. Normal time to fill the sampler was 2 hr. The volumes collected ranged up to 400 ml. The sampler was retracted to the surface and the water sample was transferred to a new, precleaned glass

sample jar. The water was shipped under refrigeration (32°F) to the analytical laboratory.

Decontamination of the soil and groundwater samplers was performed after each sampling event. Each sampler was taken apart, thoroughly cleaned using a hand-held steam cleaner wand, and reassembled. The Soil Sampler liner tube was replaced with a new one, and the groundwater sampler screen was also replaced.

As previously stated, a robust sampling program was not originally designed for the Fort Dix site investigation. Obtaining soil and groundwater samples was a task pursued as the site investigation progressed and it became evident that relatively low-level fluorescence activity predominated at the initial sites visited. Samples were then taken to determine whether or not the fluorescence activity was due to the presence of hydrocarbon compounds in the soil matrix, and to verify the fluorometer response performance. Samples were taken from soil layers exhibiting consistent in situ fluorometer responses above background levels in order to maximize the probability of retrieving representative samples for laboratory analysis. Further discussion of sampling scheme and circumstances is included in later sections of this report.

4 Results and Discussion

General

Thirteen sites within Fort Dix were chosen as candidates for SCAPS investigations based on previous studies and historical data that indicated probable POL contamination in the soil. The site locations are shown in Figure 11. The thirteen sites selected are listed in Table 1. The general work plan followed at each site investigated produced the following information:

- a.* An initial evaluation of the probable existence and source of contamination and an assessment of its probable direction of movement.
- b.* Data on the level of fluorescence intensity observed in the soil.
- c.* Data on the variation of soil strength and the inferred soil type.
- d.* Quantitative estimates of contaminant concentration based on analytical laboratory verification results.
- e.* Three-dimensional visualizations showing the distribution of the fluorescent soil in cases where adequate data density permitted such.

The plots of data from each penetration are presented in the appendixes. The plots each consist of five panels that display the cone resistance, sleeve friction, and inferred soil type as functions of depth of penetration. Soil fluorescence in normalized counts is presented on the right side of the plot along with the wavelength for the maximum fluorescence observed. All data are corrected for relative sensor positions along the SCAPS probe to read at common depths horizontally across the plot. The depth is displayed as elevation in feet above MSL for a common reference point.

The numbering system for labeling each soil penetration completed by the SCAPS at Fort Dix consists of a six-digit number: the first two digits indicate the month, the second two indicate the day, and the last two indicate the order. For example, penetration 1024-01 indicates the first penetration completed on the 24th day of October (1992). Penetrations during the months of January (01) and February (02) were in the year 1993.

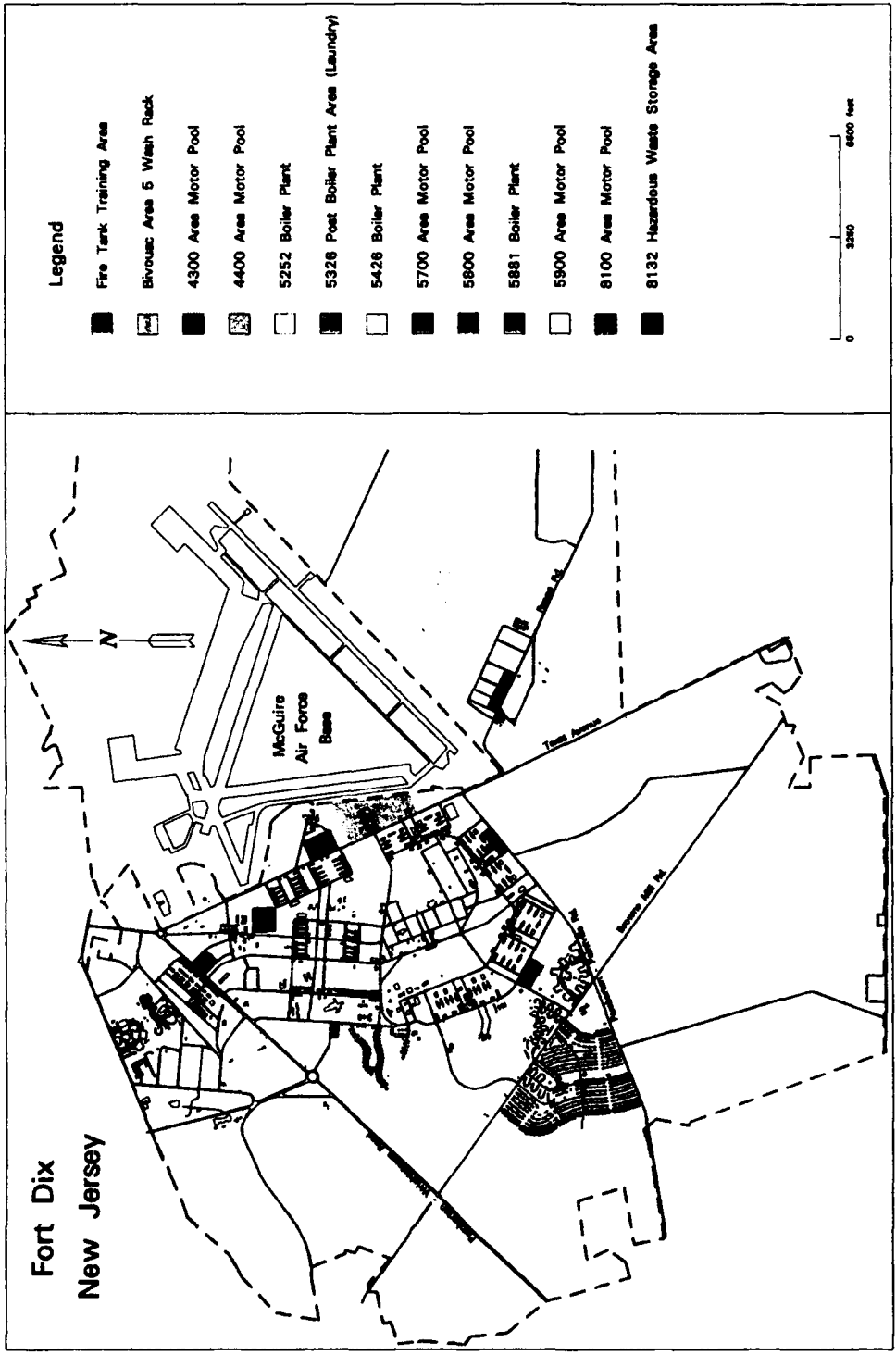

Figure 11. Map of investigation site locations

**Table 1
Summary of Sites Investigated at Fort Dix**

Site/Size	No. of Pushes	No. of Soil/ Groundwater Samples	Max. Depth of Investigation ft	Depth to Groundwater ft	Sampling Remarks	Site Conditions
Bivouac Area 5 Washrack, 6 acres	11	5	36	10	Water and soil (lab) samples show TRPH <25 ppm.	Flat, wooded, sandy.
Fire Tank Training Area, 4 acres	22	7	37	10	Water and soil (lab) samples show TRPH <25 ppm. Soil sample shows 30 ppm oil and grease. Traces of PAH in soil.	Grassed slope to stream.
4300 Area Motor Pool, 14 acres	10	0	33	7		Flat, paved.
4400 Area Motor Pool, 130 acres	130	14	57	6-19	Five soil samples (lab) show TRPH >1000 ppm.	Sloped field, flat grassed, and paved areas.
5252 Boiler Plant, 1 acre	5	0	27	15		Flat, land- scaped, grassed.
5326 Post Boiler Plant (Laundry), 5 acres	8	7	37	8	Water and soil samples (lab) show TRPH <25 ppm.	Flat, land- scaped, grassed.
5426 Boiler Plant, 4 acres	15	0	47	18		Flat, land- scaped, grassed.

(Continued)

TRPH = Total Recoverable Petroleum Hydrocarbons (EPA Method 418.1).

PAH = Polynuclear Aromatic Compounds (EPA Method 8270).

ppm = Parts per million.

Note: Lab samples were verification samples taken on site.

Table 1 (Concluded)

Site/Size	No. of Pushes	No. of Soil/ Groundwater Samples	Max. Depth of Investigation ft	Depth to Groundwater ft	Sampling Remarks	Site Conditions
5700 Area Motor Pool, 7 acres	14	0	30	8		Sloped, landscaped, grassed.
5800 Area Motor Pool, 6 acres	17	2	30	20	Soil samples (lab) show TRPH <25 ppm. Mineral fluorescence noted.	Sloped, landscaped, grassed.
5881 Boiler Plant Area, 7 acres	14	1	36	20	Soil samples (lab) show TRPH <25 ppm. Mineral fluorescence noted.	Sloped, wooded, landscaped frontage.
5900 Area Motor Pool, 20 acres	18	0	24	15		Sloped pavement wooded perimeter.
8100 Area Motor Pool, 21 acres	10	0	33	8		Flat, landscaped, pavement.
8132 Hazardous Waste Building and Storage Area, 1 acre	11	0	30	8		Flat, pavement, wooded perimeter.

TRPH = Total Recoverable Petroleum Hydrocarbons (EPA Method 418.1).

PAH = Polynuclear Aromatic Compounds (EPA Method 8270).

ppm = Parts per million.

Note: Lab samples were verification samples taken on site.

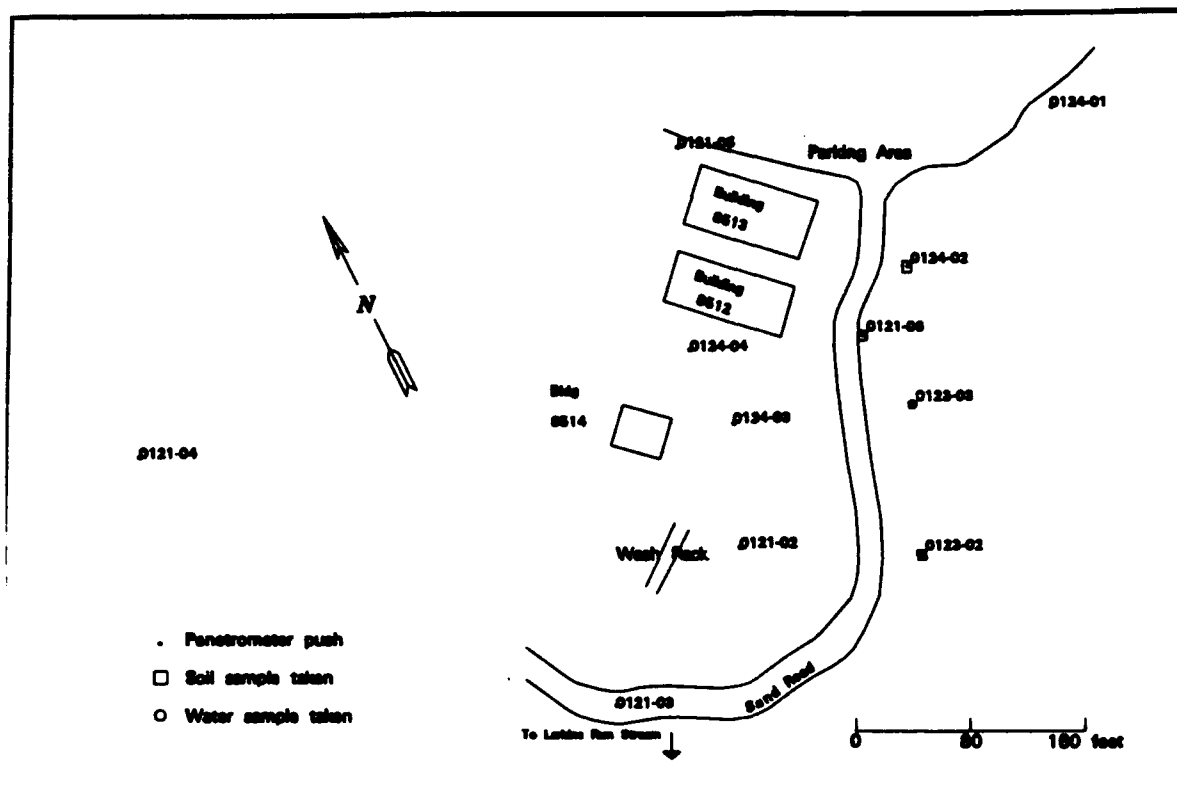

Figure 12. Bivouac Area 5 Washrack site map

silt/clay layer less than 2 ft thick, located at a depth of approximately 18 ft. The fluorescence increased where the silt/clay layer was more clearly defined. Sands/gravels predominated at this site.

Three soil and two water verification samples were taken from the Bivouac Washracks Area. The results of the laboratory analyses are shown in Tables 2 and 3. Detailed sample information is given in Appendix A. None of the samples showed levels of total recoverable petroleum hydrocarbons (TRPH) that were greater than 25 ppm (laboratory analytical limits). Although in situ fluorescence was noted under the parking area north of the washracks, none of the samples taken from this site showed evidence of TRPH contamination in laboratory analysis. Samples of soil and water taken from the fluorescent, silt-rich horizon showed higher levels of TOC than the samples collected where no fluorescence was noted, supporting a linkage between TOC concentration and fluorescence response.

The location of the fluorescence was in the first confining layer near the water table. The fluorescence is more likely due to dispersed hydrocarbon that has been held in the fine-grained soil layer as the water table fluctuated above and below the layer. One possible explanation is that the drainage from the sandy parking area and the uncontrolled washrack water discharge have caused a minor concentration (below laboratory detection limits of 25 ppm) of POL residue to accumulate in the less permeable silt/clay layer at approximately 18 ft below ground surface south and east of the parking area.

Table 2
Results of Laboratory Analysis for TOC and TRPH for the Bivouac Area 5 Washrack Area Samples

Sample No.	Total Organic Carbon ppm	Total Recoverable Petroleum Hydrocarbons ppm	Location/Type of Sample
29292	23	<0.5	Water sample next to 0123-02 10 ft BGS no fluorescence
29280	1613	<25	Soil sample next to 0121-06 2 ft BGS no fluorescence
28542	275.5	<0.5	Water sample 17.5 ft BGS, next to 0123-03
29290	1802	<25	Soil sample 18 ft BGS next to 0123-02 fluorescence noted

BGS = Below Ground Surface (Typical for all Tables).
 Note: All samples are verification samples (Typical for all Tables).
 See Appendices for sample information (Typical for all Tables).

Table 3
Results of Laboratory Analysis for PAH Compounds for the Bivouac Area 5 Washrack Area Samples

Analyte	Concentration, ppm	
	Sample No. 29517 ¹	Sample No. 29527 ²
Naphthalene	<0.71	<0.84
Acenaphthylene	<0.71	<0.84
Acenaphthene	<0.71	<0.84
Fluorene	<0.71	<0.84
Phenanthrene	<0.71	<0.84
Anthracene	<0.71	<0.84
Fluoranthene	<0.71	<0.84
Pyrene	<0.71	<0.84
Chrysene	<0.71	<0.84
Benzo(a) Anthracene	<0.71	<0.84
Benzo(k) Fluoranthene	<0.71	<0.84
Benzo(a) Pyrene	<0.71	<0.84
Indeno (1, 2, 3 - C, D) Pyrene	<0.71	<0.84
Benzo (G, H, I) Perylene	<0.71	<0.84

¹ Taken from 0121-06, 2 ft BGS.

² Taken from 0123-02, 18 ft BGS.

Fire Tank Training Area

The Fire Tank Training Area is located southeast of the Building 5353 Firehouse on Delaware Avenue (Figure 13). This area contained open steel circular tanks used for fire training exercises. It is a grassed area of approximately 2 acres bounded on the north side by a fenced vehicle maintenance facility, on the south side by a pine plantation, and on the east side by a stream. The area was used for fire training exercises from the 1960's until the 1980's, and contains two 30-ft diam soil berms. One of the berms surrounds an open steel tank 15 ft in diameter.

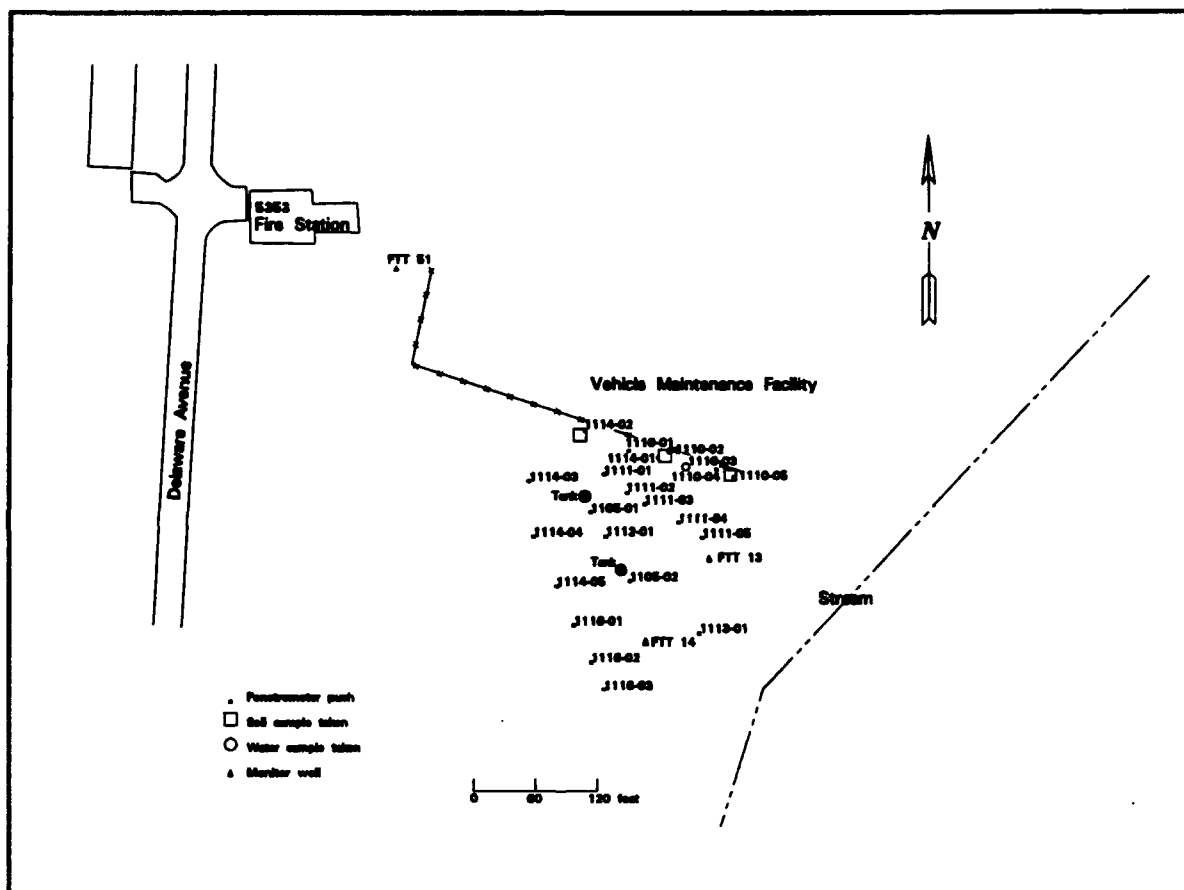

Figure 13. Fire Tank Training Area site map

The ground surface elevation drops approximately 13 ft over a distance of about 400 ft from the firehouse lawn down to the stream. The surface water and groundwater flow directions are toward the stream to the southeast, and the water table is approximately 11 ft below ground surface at the upper end of the site. The stream surface is about 1 ft below the surrounding marshy banks during normal flow. The average linear groundwater flow velocity at the site was estimated to be 10 ft per year. Three monitoring wells (FTT 51, 13, and 14) have been installed at this site and previous investigations have been conducted. Soil and water contamination has been previously detected. (Dames and Moore 1991).

The SCAPS unit was deployed at this site primarily to assist in detection of hydrocarbons in the soil and groundwater. Since the potential source and approximate extent of subsurface contamination was known (based on previous studies), a grid was established to define the extent of any possible hydrocarbon plume. Initial penetrations 1105-01 and 1105-02 were located adjacent to each berm where surface soil samples indicated POL contamination might be present. The remainder of penetrations (1110-01 through 1116-03) was set up on a grid perpendicular to the stream orientation in the expectation that contaminant concentrations would increase in the direction of the stream. A total of 22 penetrations were made at this site. A wide range of soil types was observed, from gravels to clays. The soil stratigraphy variation was among the highest observed at any site visited.

Fluorescence was observed most predominantly in the northern section of the site. The data are presented in Appendix B. Twenty-two pushes provided enough data to prepare a map showing the distribution of fluorescence in the subsurface (Figures 14-17). Each of the four plates shows different three-dimensional orientations of the site. Part "a" shows the lowest fluorescence intensity data, and Part "b" shows the highest intensity data for each orientation. Note that the most intense fluorescence responses (300 to 1,000 counts) were found between the fire training tanks and the vehicle maintenance facility on the northern part of the site.

Water and soil samples were collected and analyzed both from materials that showed fluorescence and those that did not. Tables 4 and 5 highlight the TOC, TRPH, and PAH laboratory results. Details of sampling locations and adjacent in situ fluorescence patterns are presented in Appendix B. The water sample that showed fluorescence contained 0.7 ppm TRPH (Table 4). The water sample that did not fluoresce showed 0.1 ppm. Both of the soil samples show TRPH levels that were below the detection limits for the conventional laboratory analytical methods. The TOC levels ranged from 42 to 11,237 ppm. One soil sample collected from the fluorescent horizon showed 30 ppm of oil and grease although the TRPH was less than the conventional detection limit (25 ppm). The soil samples that fluoresced had a dark color, suggesting discoloration with POL residue. The discolored sample and the consistent in situ fluorescence at the site prompted further analytical work and a screen for polynuclear aromatic hydrocarbons was undertaken on the two soil samples (one assumed to be clean and the second suspected of contamination) from the site. Both of the respective samples showed PAH concentrations of 730 to 940 ppb (Table 5). The soil sample that exhibited detectable fluorescence did show indications of low PAH concentrations, including 190 ppb of the fluorophore perylene.

The fluorometer and laboratory results obtained in this investigation indicate that no high level POL contamination over any large area was observed in the subsurface at the Fire Tank Training Area. Only one penetrometer push (1114-01) showed evidence of a high level of contamination. The maximum fluorescence intensity occurred in a clay/peat lense at elevation 113-ft MSL. None of the penetrometer pushes or sampling conducted nearby indicated any comparable contamination. The detection of a trace of PAH

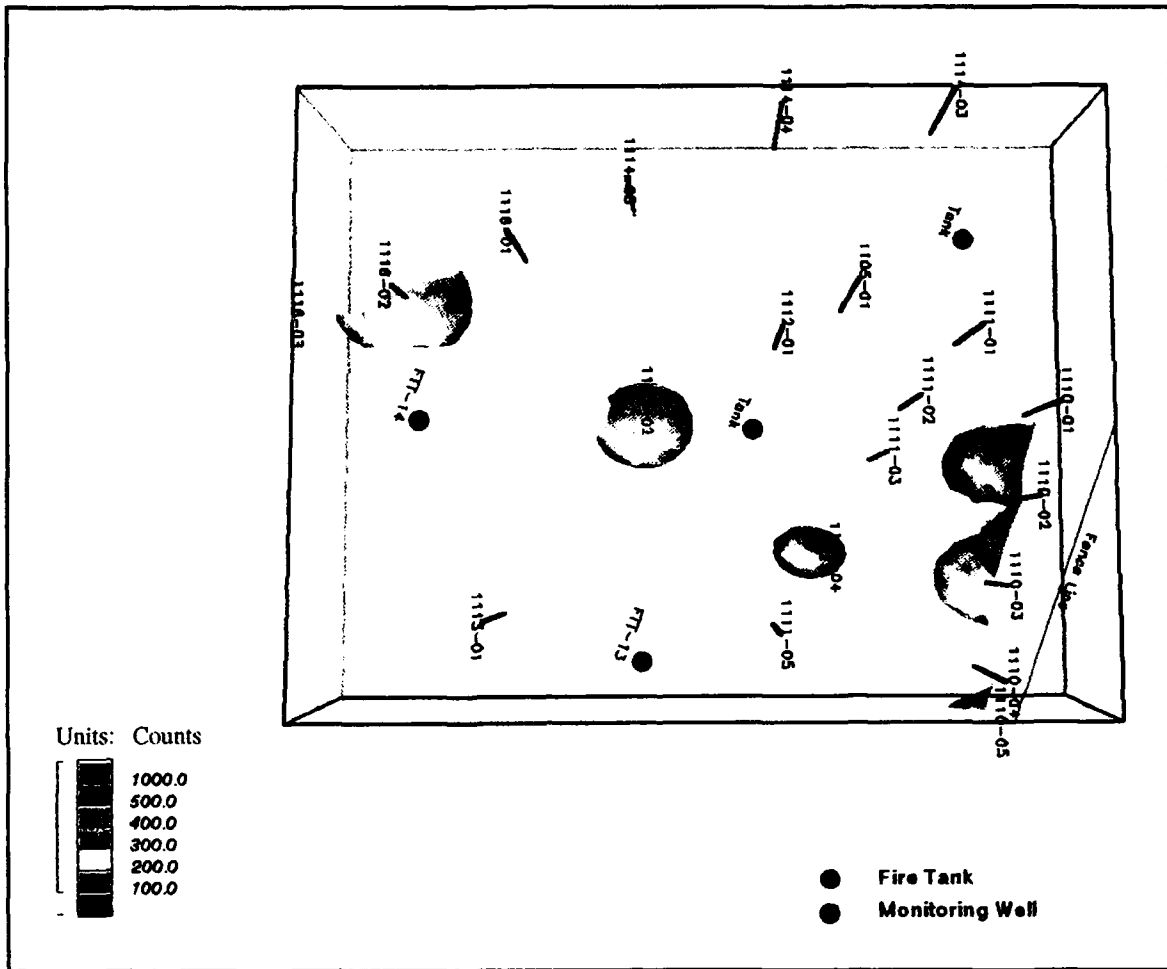

Figure 14a. Fire Tank Training Area 3-D visualization, view 1

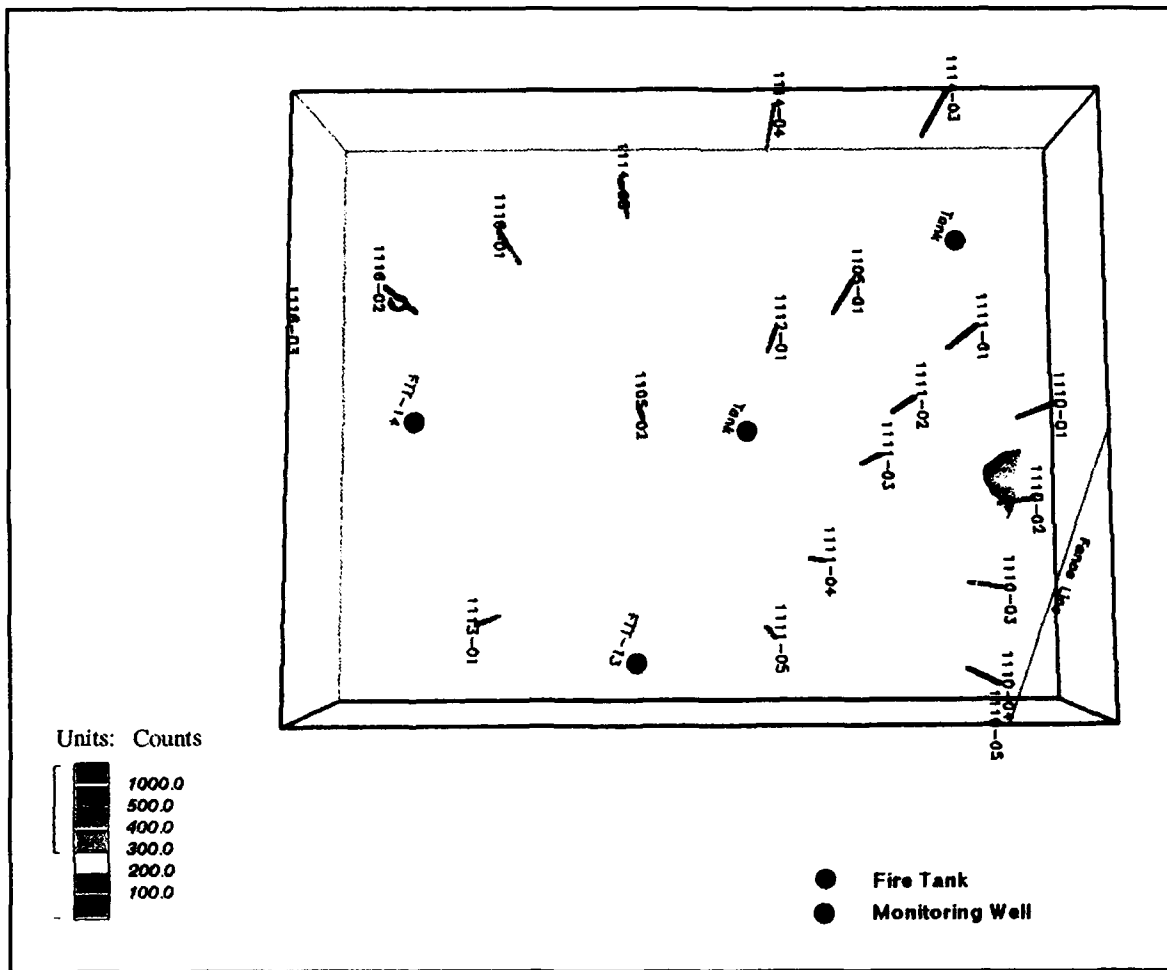

Figure 14b. Fire Tank Training Area 3-D visualization, view 1

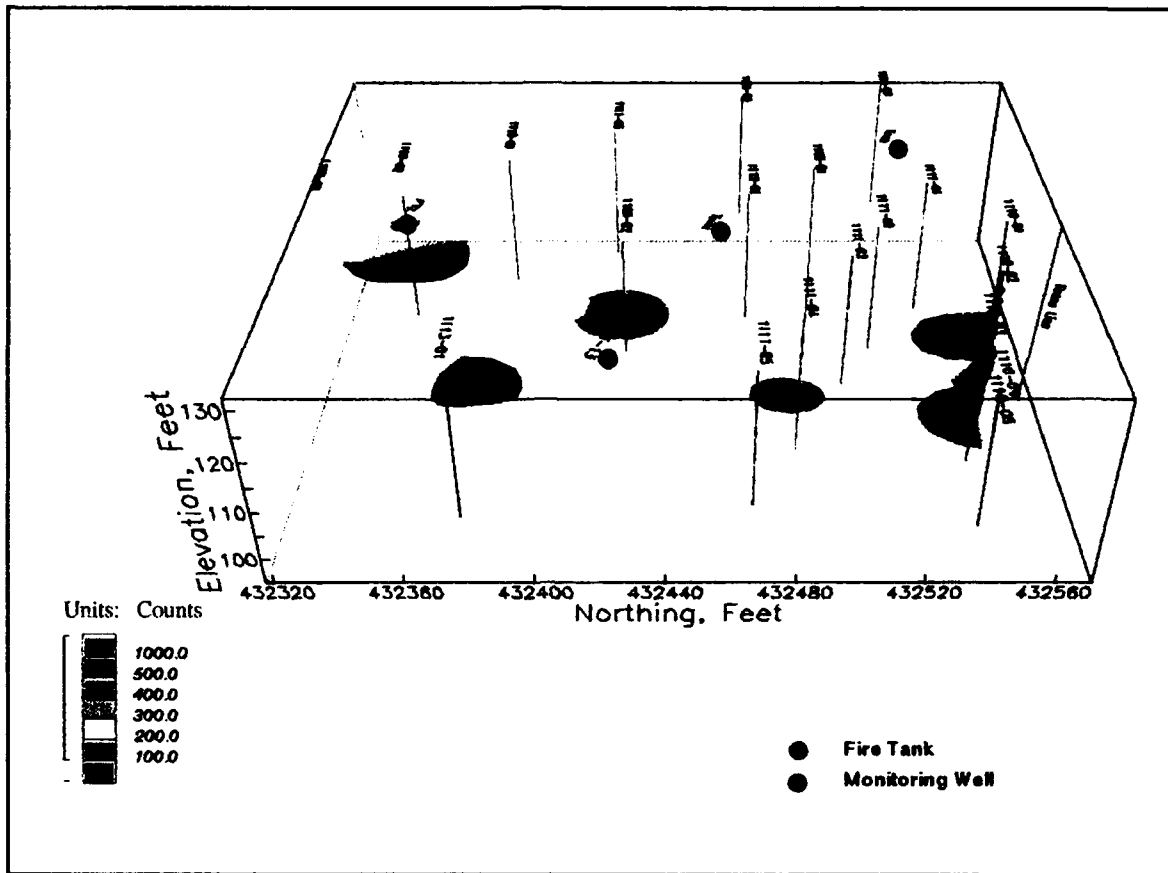

Figure 15a. Fire Tank Training Area 3-D visualization, view 2

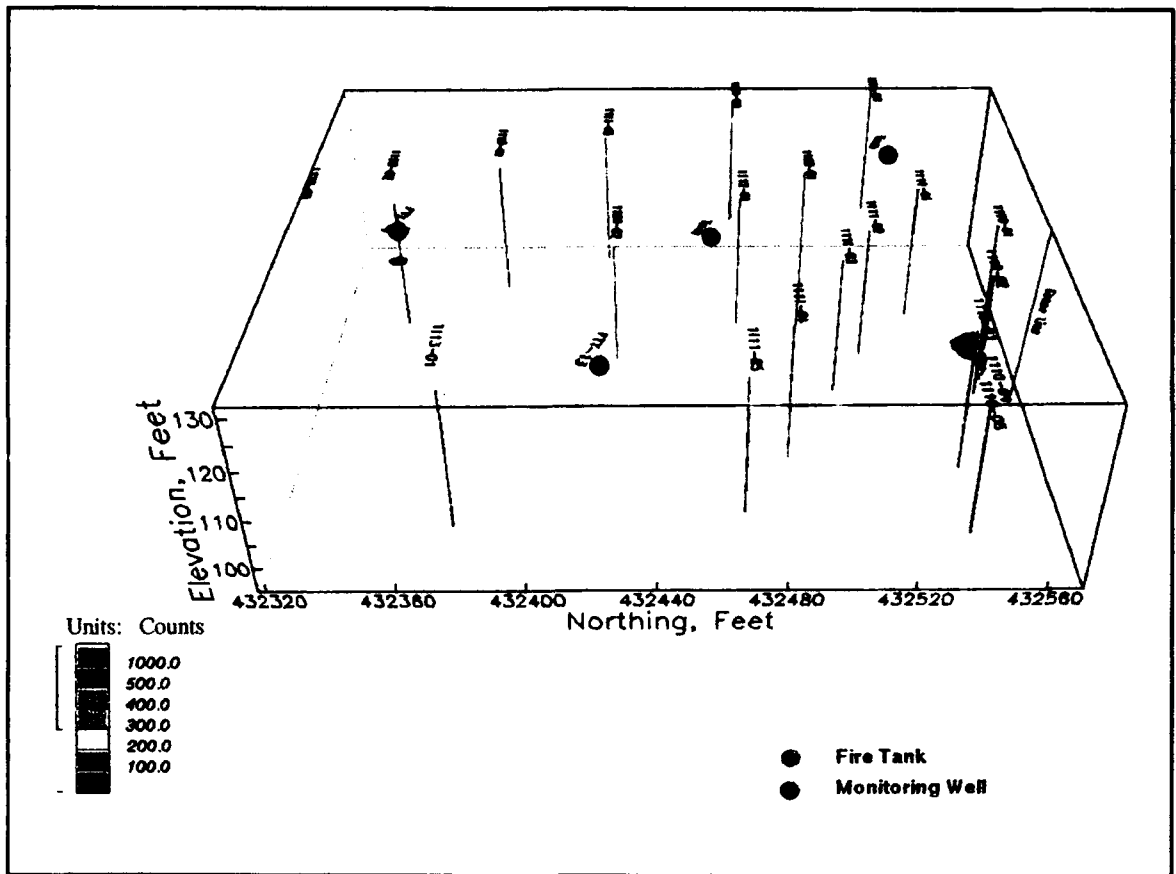

Figure 15b. Fire Tank Training Area 3-D visualization, view 2

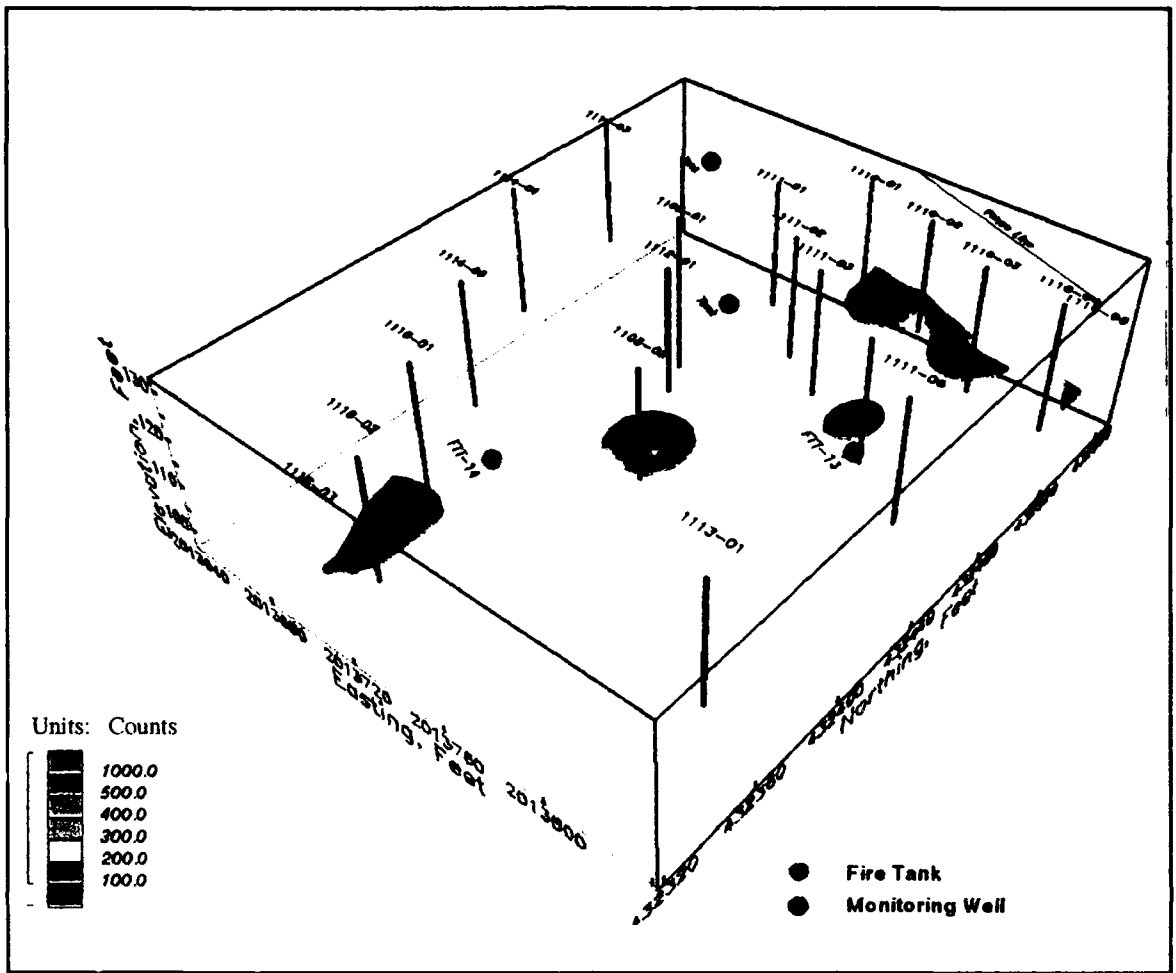

Figure 16a. Fire Tank Training Area 3-D visualization, view 3

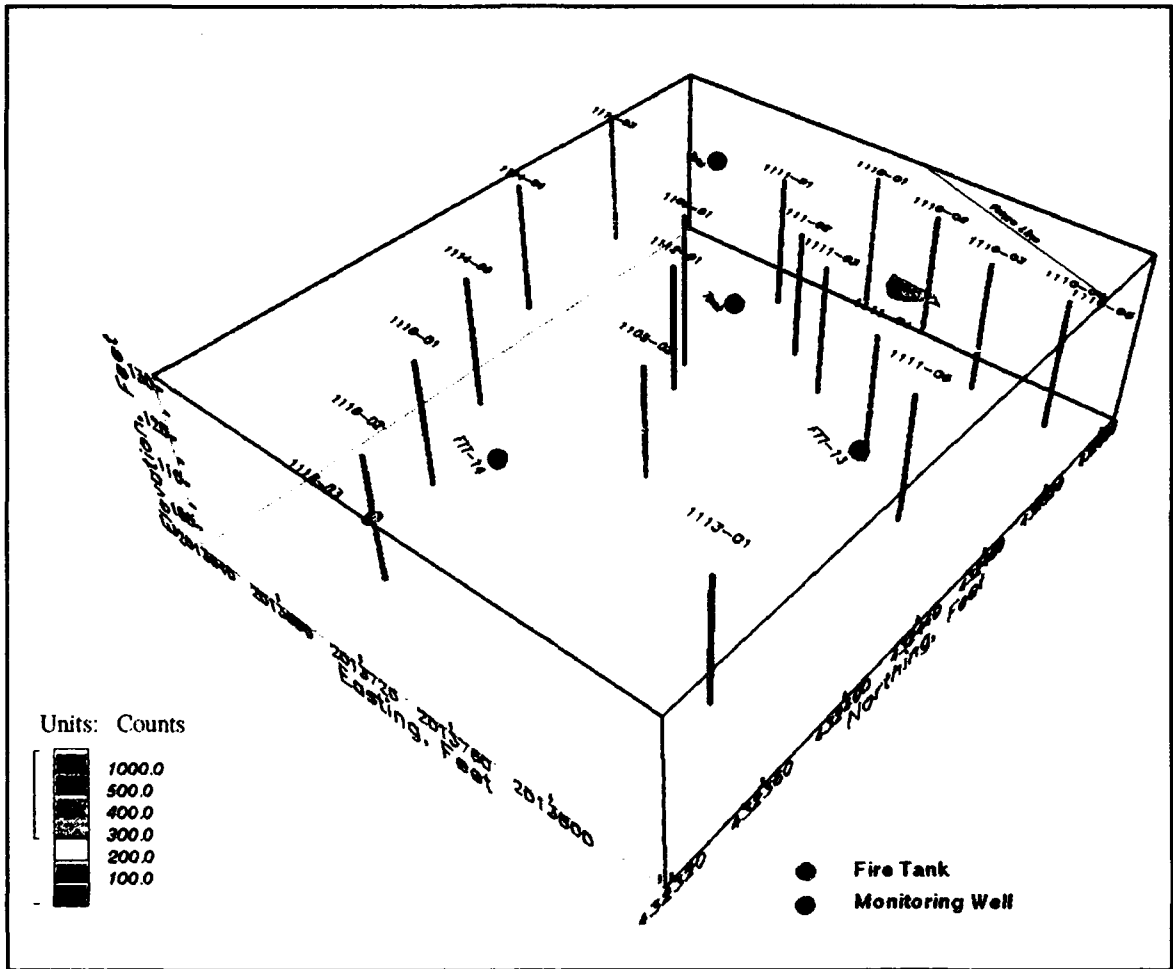

Figure 16b. Fire Tank Training Area 3-D visualization, view 3

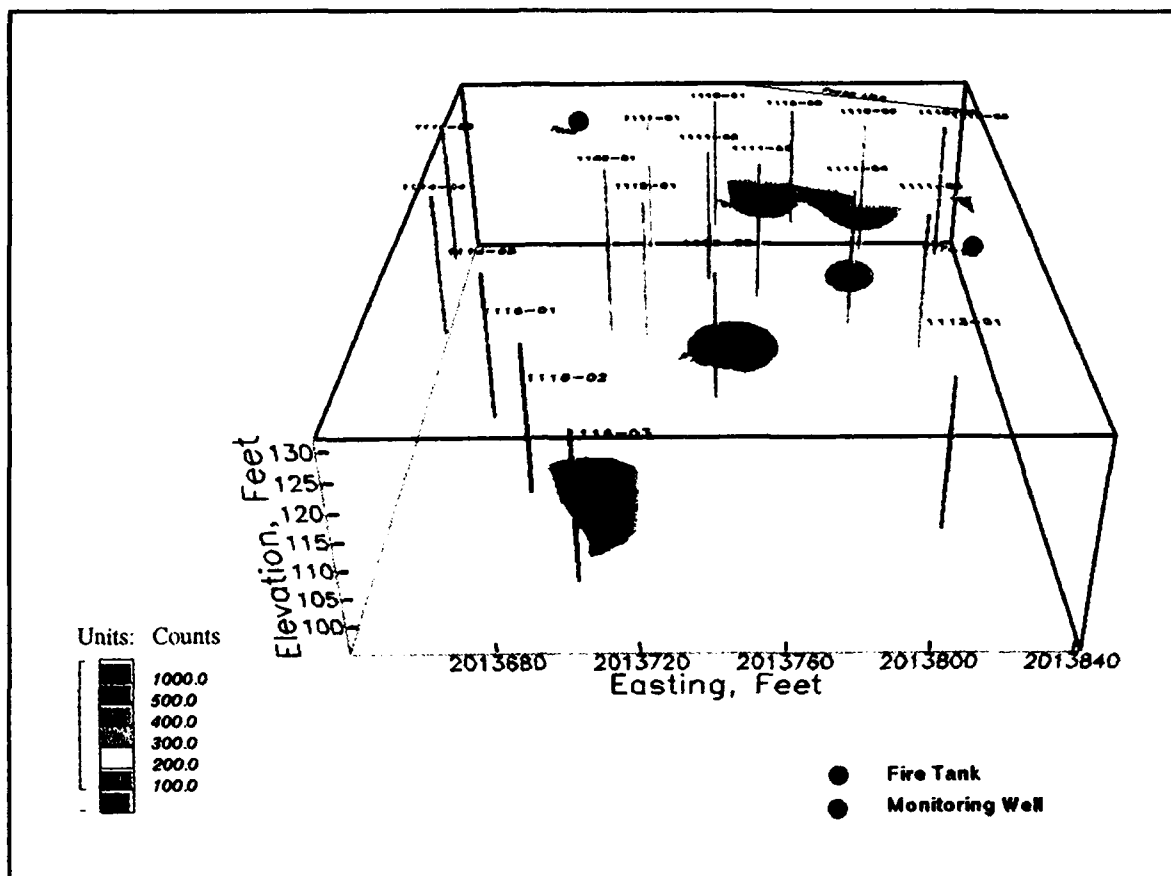

Figure 17a. Fire Tank Training Area 3-D visualization, view 4

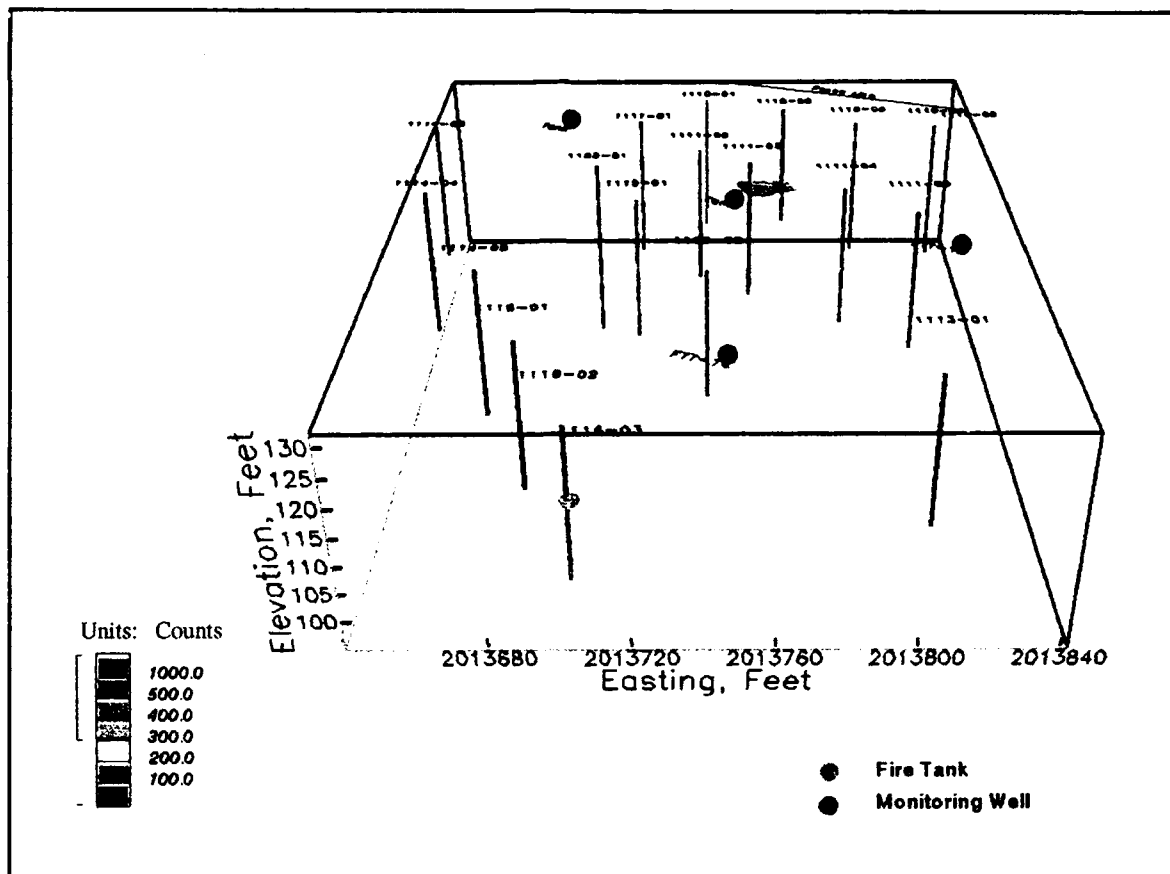

Figure 17b. Fire Tank Training Area 3-D visualization, view 4

**Table 4
Results of Laboratory Analysis for TOC and TRPH for the Fire Tank Training Area Samples**

Sample No.	Total Organic Carbon ppm	Total Recoverable Petroleum Hydrocarbons ppm	Location/Type of Sample/Sample Fluorescence
29291	42	0.7	Water sample taken next to 1110-03, 19 ft BGS, (Non-fluorescing)
29293	34.0	0.1	Water sample taken next to 1110-03, 10 ft BGS, (Non-fluorescing)
29283	2842	<25.0	Soil sample taken next to 1110-02, 1 ft BGS, (Non-fluorescing)
29287	11237	<25.0	Soil sample taken next to 1110-03, 18 ft BGS, (Fluorescing)
26942	Not Analyzed	<25.0 (3 ppm oil and grease)	Soil sample taken from surface near fence, (Fluorescing)
26810	Not Analyzed	<25 (<25 ppm oil and grease)	Soil sample taken next to push 1110-05, 15 ft BGS, (Fluorescing)
26811	Not Analyzed	<25 (30 ppm oil and grease)	Soil sample taken next to push 1114-02, 17 ft BGS, (Fluorescing)

(perylene), a sample containing 30 ppm oil and grease in the fluorescing soil samples taken at the site, and the measurable TRPH in the water sample that fluoresced all indicate presence of POL compounds at this site.

The highest fluorescence activity trend was observed in the area immediately south (downgradient) of the fence line separating the Fire Tank Training Area from the vehicle maintenance facility. Such activity suggests that, other than isolated events in the Fire Tank Training Area, an area of concern for future investigation would be the vehicle maintenance facility on the north side of the fence line. Additional sampling along the fence line area may be warranted.

4300 Area Motor Pool

The 4300 Area Motor Pool (Figure 18) is located between Texas Avenue and the sewage treatment plant. It contains a refueling center (buildings 4303, 4304, 4305, building 4302), and a large paved parking area. The Motor Pool has been part of an ongoing remediation program. Several underground fuel storage tanks have been removed and an underground waste oil storage tank located south of building 4302 has been replaced.

**Table 5
Results of Laboratory Analysis for PAH compounds for the Fire
Tank Training Area Samples**

Analyte	Concentration, ppm	
	Sample No. 29520 ¹	Sample No. 29524 ²
Naphthalene	<0.73	<0.94
Acenaphthylene	<0.73	<0.94
Acenaphthene	<0.73	<0.94
Fluorene	<0.73	<0.94
Phenanthrene	<0.73	<0.94
Anthracene	<0.73	<0.94
Fluoranthene	<0.73	<0.94
Pyrene	<0.73	<0.94
Chrysene	<0.73	<0.94
Benzo(a) Anthracene	<0.73	<0.94
Benzo(k) Fluoranthene	<0.73	<0.94
Benzo(a) Pyrene	<0.73	<0.94
Indeno (1, 2, 3 - C, D) Pyrene	<0.73	<0.94
Benzo (G, H, I) Perylene	<0.73	<0.94
Perylene	ND	0.19

¹ Taken next to 1110-02, 1 ft BGS.
² Taken next to 1110-03, 18 ft BGS.
ND = Not determined.

Several tons of petroleum-contaminated soil were removed from the south side of the Motor Pool area in 1985. Monitoring wells (363-24, 363-25, and 363-26) were installed at that time; no petroleum hydrocarbons or VOCs were discovered in the groundwater (EA 1989). Surface and groundwater flows are to the south; the stream drainage from Willow Pond (across Texas Avenue) is the potential receptor for runoff. Its surface elevation is approximately 10 ft below the 4300 Area pavement elevation.

Ten SCAPS fluorometer probe penetrations were completed within the 4300 Area (Appendix C). The majority of these were sited along the south fence line in the expectation that any groundwater contamination flowing southward would be intercepted. The remainder were sited in the pavement area south of the refueling buildings and adjacent to the underground waste oil tank south of building 4302. The soil stratigraphy consists of sands with interbedded finer-grained material. The soil at penetration 0113-02 contains a clay lense (15 ft thick), and is possibly a backfilled area.

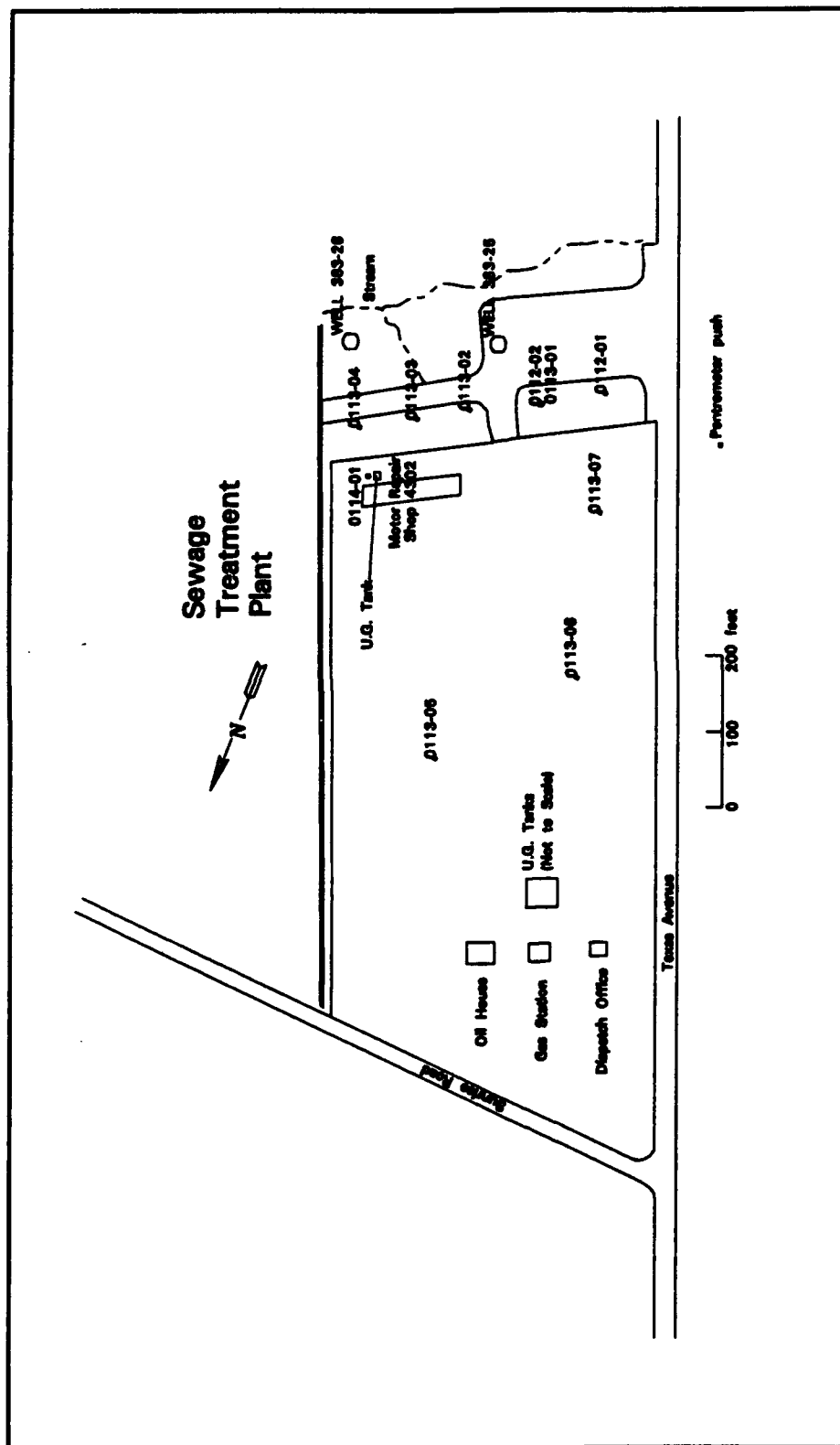

Figure 18. 4300 Area Motor Pool site map

Fluorescence was observed approximately 5 to 15 ft below the ground surface in four penetrations along the south side (0112-01 and 0113-02 through 0113-04). It is assumed that this low-level intensity of fluorescence (less than 100 counts) indicates possible hydrocarbon dispersion from the previously contaminated soil excavation performed in this area. This assumption is further justified by the 3-ft average thickness of the fluorescing soil layers. No other suspected contaminant sources are nearby, and the fluorescent soil interval is above the water table which suggests that lateral transport has not occurred.

Penetrations 0113-05 through 0113-07 were conducted beneath the paved parking area. Fluorescence (less than 200 counts) was observed at a depth of approximately 25 to 30 ft below the pavement surface. At this depth, a finer-grained soil layer is present. The fluorescence increase is similar to the pattern observed in fine-grained soil layers at several other investigation sites (including the Bivouac Washrack site, and the Fire Tank Training Area). It is assumed that the fluorescence observed is possibly related to remnant hydrocarbons from the previously-excavated underground fuel tanks located approximately 200 ft north. This soil layer is located approximately 20 ft below the water table elevation (115 ft MSL) as recorded in 1990 and 1991 at the nearby monitoring wells 363-25 and 363-26.

Penetration 0114-01 was located immediately downgradient of the underground waste oil tank outside building 4302. Fluorescence (less than 100 counts) was observed approximately 12 ft below ground surface. Since an underground tank had been previously removed and replaced at the site, it is reasonable to assume that the fluorescence is a result of dispersed low-level hydrocarbon contamination from the tank removal process. No soil or water samples were collected at this site.

No evidence of a well-defined, continuous, or highly concentrated plume of hydrocarbon presence in the soil or groundwater was observed at this site (based on the fluorometer data). The available monitor well sampling results serve to supplement such a conclusion. Evidence does exist that hydrocarbons have been present in the soil and groundwater, based on ongoing and past remediation efforts and the fluorometer data. Further investigations to establish the locations and pinpoint possible sources of persistent hydrocarbons may be warranted. A likely candidate for future investigation efforts would be in the unpaved area south of the 4300 Area pavement, especially in the gravel parking area near penetrations 0112-01, and 0113-02 through 0113-04. Additional investigation efforts in the vicinity of 0113-05 and 0113-07 may also be warranted, based on in situ fluorometer responses.

4400 Area Motor Pool

The 4400 Area Motor Pool investigation site covers an area of approximately 30 acres, extending from a cemetery (near the intersection of Texas Avenue and Pointville Road) north to the Willow Pond overflow stream. The

entire area lies to the east of Texas Avenue, and includes buildings 4429 through 4434; buildings 4439 and 4440; buildings 4465 through 4471; and the Army Airfield complex. The investigation also included an area east of the Army Airfield fence to the McGuire Air Force Base (AFB) taxiway H (Figure 19).

Several documented underground storage tanks, oil/water separators, and vehicle washracks are located in this area. Prior waste oil spills have occurred near buildings 4429 and 4434 and the contaminated soils were removed. In 1986, four monitoring wells (DIO-09, DIO-10, DIO-11, and DIO-12) were installed around these buildings; no volatile organics or semi-volatile organics were detected in any of these monitoring wells (EA 1989).

The ground surface elevation ranges from 143 ft above MSL in the southern area to 123 ft above MSL near the Army Airfield. The natural surface drainage occurs in a northeasterly direction toward the Army Airfield and McGuire AFB. Open drainage ditches are present east of the 4468 Motor Pool Repair Shop and east of the Army Airfield. Expected groundwater flow direction is also northeasterly. Soil borings taken before construction of the 4468 Motor Pool Repair Shop (May 1965) indicated a water table depth of 16 ft below ground surface. Measured depth to the water table during this site investigation (taken near the Repair Shop) was 13 ft below ground surface (water surface elevation 121 ft above MSL). Measured depth to the water table at the lowest site elevation (near the Army Airfield) was approximately 6 ft below ground surface (water surface elevation 117 ft above MSL). Measured depth to the water table at the highest surface elevation in the investigation area (south, near the cemetery) was 19 ft below ground surface (water surface elevation 126-ft MSL). The groundwater surface elevation dropped approximately 9 ft to the northeast across the 4400 Area Motor Pool site. The soil layering at the site typically consisted of a silt/clay surface (up to 5-ft thickness), a coarse sand layer (up to 10-ft thickness), and a fine sand layer below. Many interbedded layers of different textures were present, especially in the lower fine-sand layer. The water table surface typically was at or near the top of the fine sand layer.

A total of 130 penetrations were completed in the 4400 Area. Twenty-four verification samples were analyzed (Tables 6, 7, and Appendix D). The primary investigation targets were subsurface soil and groundwater near the washracks, oil/water separators, and underground waste oil storage tanks. The initial site of investigation was adjacent to the 4468 Motor Pool Repair Shop washracks and oil/water separator. Low-level (less than 100 count intensity) fluorescence was observed during many of these penetrations, and the investigation site was broadened as it became evident that discrete fluorescence patterns were found not to be associated with specific facilities. The three-dimensional plume modeling of the data supported this observation.

The peak fluorescence intensities (greater than 100 counts) occurred at various depths in each penetration event exhibiting a fluorescence response. The peak intensities (fluorescence with the highest intensity counts) occurred in the finer-grained soil layers, often sandwiched between sand layers. No

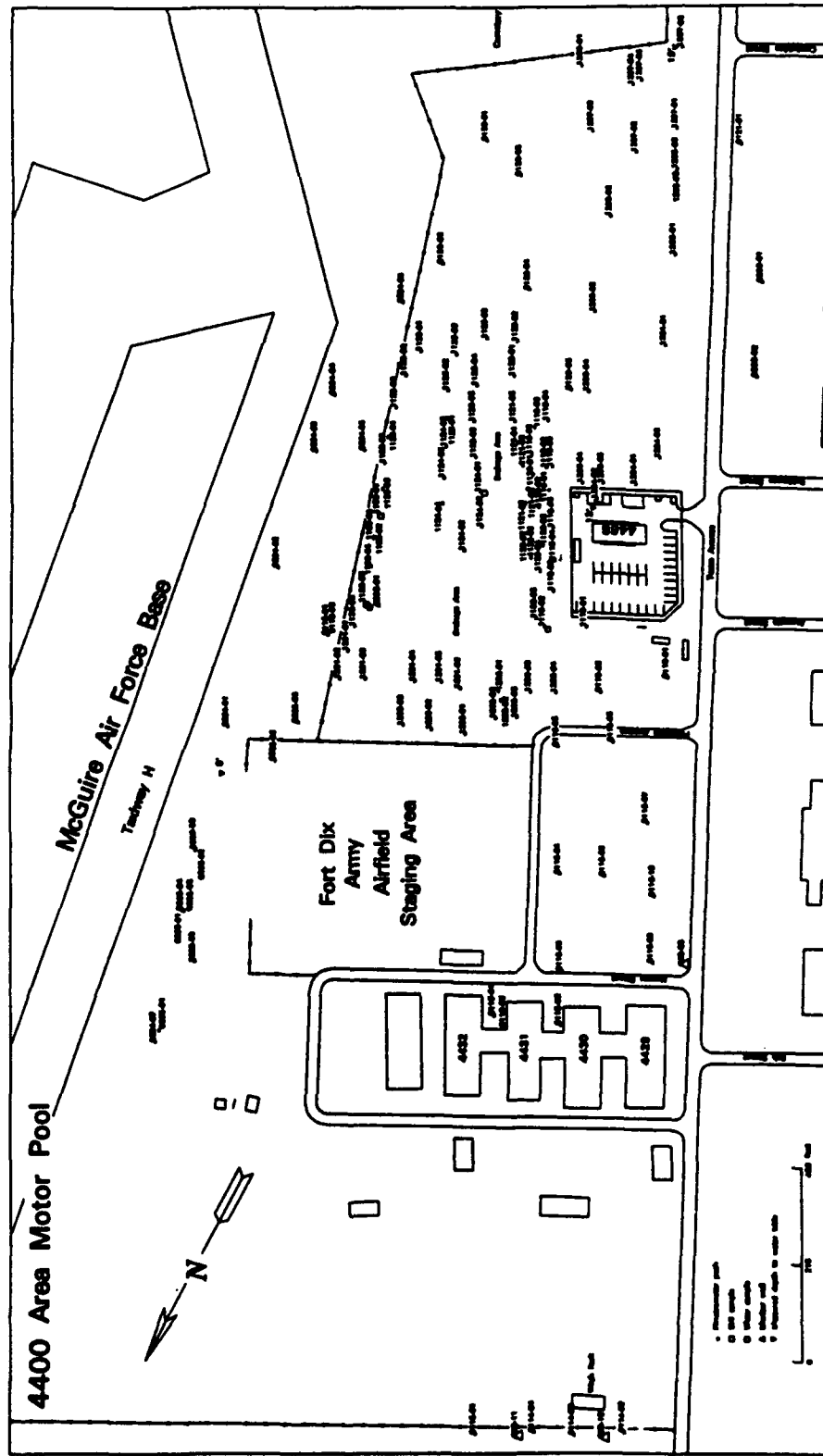

Figure 19. 4400 Area Motor Pool site map

**Table 6
Results of Laboratory Analysis for TOC and TRPH for the 4400
Area Motor Pool Samples**

Sample No./Type	Total Organic Carbon ppm	Oil and Grease ppm	Total Recoverable Petroleum Hydrocarbons ppm	Location
27875 (Water)	4.8	N/A	<0.5	Taken next to 0118-02, 12 ft BGS (Fluoresced)
29294 (Water)	35.0	N/A	0.1	Taken next to 1130-05, 28 ft BGS (Non-fluorescing)
27493 (Concrete)	N/A	N/A	6.0	Taken next to 1205-02, 1 ft BGS (Fluoresced)
27492 (Soil)	N/A	N/A	<25.0	Taken next to 1130-01, 6 ft BGS (Fluoresced)
29289 (Soil)	1578	N/A	<25.0	Taken next to 1130-05, 6 ft BGS (Fluoresced)
29288 (Soil)	1256	N/A	<25.0	Taken next to 1130-05, 11 ft BGS (Fluoresced)
31391 (Soil)	N/A	460	430	Taken next to 0116-02, at a depth of 6.8-7.2 ft BGS (Fluoresced)
31392 (Soil)	N/A	8200	7900	Taken next to 0116-02, at a depth of 7.4-7.8 ft BGS (Fluoresced)
31393 (Soil)	N/A	110	25	Taken next to 1130-01 at a depth of 3 ft BGS (Fluoresced)
31394 (Soil)	N/A	3200	3100	Taken next to 1130-01 at a depth of 4.0-4.5 ft BGS (Fluoresced)
31395 (Soil)	N/A	1900	1800	Taken next to 1130-01 at a depth of 7.5-8.0 ft BGS (Fluoresced)
31396 (Soil)	N/A	2200	2100	Taken next to 1130-01 8.0-8.5 ft BGS (Fluoresced)
31397 (Soil)	N/A	27	7.0	Taken next to 1124-01 2.0-2.5 ft BGS (Non-fluorescing)
31398 (Soil)	N/A	3500	2700	Taken next to 1124-01 at a depth of 14.0-14.5 ft BGS (Fluorescing)

Table 7
Results of Laboratory Analysis for PAH Compounds for the 4400
Area Motor Pool Samples

Analyte	Concentration, ppm	
	Sample No. 29525 ¹	Sample No. 29526 ²
Naphthalene	<0.78	<0.76
Acenaphthylene	<0.78	<0.76
Acenaphthene	<0.78	<0.76
Fluorene	<0.78	<0.76
Phenanthrene	<0.78	<0.76
Anthracene	<0.78	<0.76
Fluoranthene	<0.78	<0.76
Pyrene	<0.78	<0.76
Chrysene	<0.78	<0.76
Benzo(a) Anthracene	<0.78	<0.76
Benzo(k) Fluoranthene	<0.78	<0.76
Benzo(a) Pyrene	<0.78	<0.76
Indeno (1, 2, 3 - C, D) Pyrene	<0.78	<0.76
Benzo (G, H, I) Perylene	<0.78	<0.76

(Sheet 1 of 5)

¹ Taken near 1130-05, 11 ft depth.
² Taken near 1130-05, 6 ft depth.

Table 7 (Continued)

Analyte	Concentration, ppm	
	Sample No. 31391 ¹	Sample No. 39392 ²
Naphthalene	1.9	5.8
Acenaphthylene	0.05	0.11
Acenaphthene	0.07	0.78
Fluorene	0.18	1.7
Phenanthrene	<0.78	0.69
Anthracene	<0.78	<0.75
Fluoranthene	<0.78	0.03
Pyrene	<0.78	0.03
Chrysene	<0.78	<0.75
Benzo(a) Anthracene	<0.78	<0.75
Benzo(b) Fluoranthene	<0.78	<0.78
Benzo(k) Fluoranthene	<0.78	<0.75
Benzo(a) Pyrene	<0.78	<0.75
Indeno (1, 2, 3 - C, D) Pyrene	<0.78	<0.75
Benzo (G, H, I) Perylene	<0.78	<0.75

*(Sheet 2 of 5)*¹ Taken near 0116-01 and 0116-02 at a depth of 6.8-7.2 ft BGS.² Taken near 0116-01 and 0116-02 at a depth of 7.4-7.8 ft BGS.

Table 7 (Continued)		
Analyte	Concentration, ppm	
	Sample No. 31393¹	Sample No. 31394²
Naphthalene	<0.74	0.07
Acenaphthylene	<0.74	<0.72
Acenaphthene	<0.74	<0.72
Fluorene	<0.74	<0.72
Phenanthrene	<0.74	0.06
Anthracene	<0.74	<0.72
Fluoranthene	<0.74	0.18
Pyrene	<0.74	0.29
Chrysene	<0.74	0.09
Benzo(a) Anthracene	<0.74	0.05
Benzo(b) Fluoranthene	<0.74	0.04
Benzo(k) Fluoranthene	<0.74	0.04
Benzo(a) Pyrene	<0.74	0.03
Indeno (1, 2, 3 - C, D) Pyrene	<0.74	<0.72
Benzo (G, H, I) Perylene	<0.74	<0.72

(Sheet 3 of 5)

¹ Taken near 1130-01, 3 ft depth BGS.
² Taken near 1130-01, 4.0-4.5 ft depth BGS.

Table 7 (Continued)		
Analyte	Concentration, ppm	
	Sample No. 31395¹	Sample No. 31396²
Naphthalene	1.1	2.9
Acenaphthylene	0.10	0.10
Acenaphthene	1.1	1.4
Fluorene	1.4	1.7
Phenanthrene	3.0	3.8
Anthracene	0.22	0.28
Fluoranthene	0.10	0.12
Pyrene	0.16	0.21
Chrysene	0.02	0.03
Benzo(a) Anthracene	<0.78	<0.80
Benzo(b) Fluoranthene	<0.78	<0.80
Benzo(k) Fluoranthene	<0.78	<0.80
Benzo(a) Pyrene	<0.78	<0.80
Indeno (1, 2, 3 - C, D) Pyrene	<0.78	<0.80
Benzo (G, H, I) Perylene	<0.78	<0.80
<i>(Sheet 4 of 5)</i>		
¹ Taken near 1130-01, 7.5-8.0 ft depth. ² Taken near 1130-01, 8.0-8.5 ft depth.		

Table 7 (Concluded)		
Analyte	Concentration, ppm	
	Sample No. 31397¹	Sample No. 31398²
Naphthalene	<7.0	<0.78
Acenaphthylene	<7.0	<0.78
Acenaphthene	<7.0	<0.78
Fluorene	<7.0	<0.78
Phenanthrene	<7.0	<0.78
Anthracene	<7.0	<0.78
Fluoranthene	<7.0	<0.78
Pyrene	<7.0	<0.78
Chrysene	<7.0	<0.78
Benzo(a) Anthracene	<7.0	<0.78
Benzo(b) Fluoranthene	<7.0	<0.78
Benzo(k) Fluoranthene	<7.0	<0.78
Benzo(a) Pyrene	<7.0	<0.78
Indeno (1, 2, 3 - C, D) Pyrene	<7.0	<0.78
Benzo (G, H, I) Perylene	<7.0	<0.78
<i>(Sheet 5 of 5)</i>		
¹ Taken near 1124-01, 2.0-2.5 ft. ² Taken near 1124-01, 14.0-14.5 ft.		

occurrence of fluorescence in the coarser sands and gravels was observed, even when peak fluorescence occurred in finer-grained layers above and below these layers. The peak intensities were observed above, at, and below the water table. The highest frequency of fluorescent peak intensity events occurred below the water table, and the fluorescent peak intensities often appeared up to 20 ft below the water table elevation. Tables 6 and 7 summarize the laboratory analytical results obtained from the 4400 Area soil and groundwater samples. Appendix D contains detailed sampling information.

In the southern end of the study area (near the cemetery) fluorescence (up to 500 counts) 1 ft below ground surface was observed during penetrations 1205-02 and 1205-03. A thin concrete surface was located at that depth, and appeared to be part of an old foundation. A sample of the concrete was analyzed for TRPH, and the results indicated contamination of 6.0 parts per million (ppm). Fluorescence observed in nearby penetrations 1207-01, 1207-02, and 1207-03 indicated possible points where surface contamination may have occurred.

Elevated fluorescence levels (greater than 100 counts) were noted in penetrations 1204-01 through 1204-03 just south of building 4468 near the fueling area, the washracks, and a buried waste oil storage tank. A more intense fluorescence response was noted in penetration 1124-01 down gradient from building 4468. In 1124-01 minor fluorescence was noted at a shallow depth and a soil sample taken from a 2.0 to 2.5 ft depth showed 3,500 ppm oil and grease and 2,700 ppm TRPH. A deeper sample taken just above the level where a second fluorescence peak was noted showed only 7.0 ppm TRPH but did show 27 ppm oil and grease. The area south and west of the area around building 4468 shows indication of POL contamination and additional sampling near 1124-01 at a greater depth may produce samples with higher levels of TRPH than noted at 14-ft depth.

On the east side of the 4400 Area (near the fence separating the 4400 Area from McGuire AFB) strong fluorescence was noted in penetration 1130-01 at depths ranging from 3.0 to 9.0 ft. Samples taken from soil near these horizons showed laboratory oil and grease concentrations ranging up to 3,500 ppm and laboratory TRPH concentrations up to 2,700 ppm. The maximum fluorescence was over 1,000 counts in a layer only 0.5 ft thick. A more typically occurring fluorescence is 150 to 200 counts which would correspond to a predicted TRPH of 3,000-4,000 ppm.

In the area near McGuire AFB, Taxiway H (vicinity of 1130-05), there was an elevated fluorescence signal (peaks to 200 counts) and insignificant laboratory evidence of POL contamination. Samples of water taken in the zone with the high count rate show a relatively high level of total organic carbon (35 ppm) but little TRPH (0.1 ppm). A sample of deicing solution used at McGuire AFB was obtained in order to see if a fluorescent dye might be appearing in the groundwater (and soil) due to deicer spraying. No historical records were made available, but indications of possible deicing activity in this area were verbally expressed. A deicing fluid fluorescence spectrum was taken and compared with a groundwater fluorescence spectrum (Figure 20).

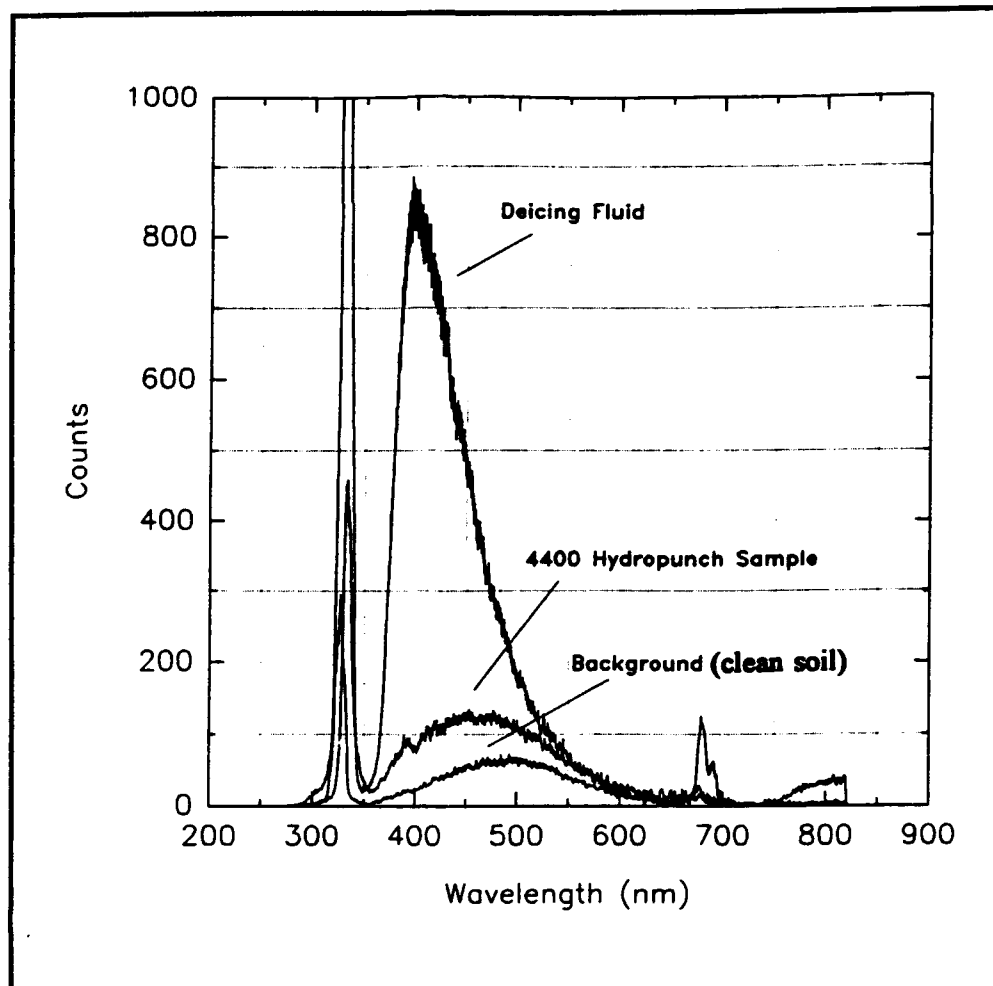

Figure 20. Fluorescence from spectra of deicing fluid and groundwater

The deicing fluid fluoresced significantly. No penetrations on the east side of the fence showed elevated fluorescence levels that substantiated the high levels observed along the west side of the fence line, indicating that the fluorescence activity is limited to the west (Fort Dix) side of the fence.

Elevated fluorescence was noted south of the Fort Dix Army Airfield Staging Area. Penetration 1203-03 shows fluorescence at levels above 200 counts. No other penetration in this area showed comparable levels of contamination. There is no general pattern that can relate the drainage from the Airfield Staging Area with POL contamination in this location.

Strong fluorescence was noted near an oil/water separator between building 4431 and 4432. Penetrations 0116-02 and 0116-03 show elevated counts at depths from 4 ft to 9 ft with the maximum count rate of over 1,000 appearing in 0116-01 and a maximum count of 200 appearing in 0116-02. Soil samples taken from a depth of 6.8 to 7.2 ft near 0116-02 showed 460 ppm oil and grease and 430 ppm TRPH. At a depth of 7.4 to 7.8 ft the concentration of oil and grease rose to 8,200 ppm and the TRPH rose to

7,900 ppm. Samples from these soils were used to develop curves for estimating the POL contamination from fluorescence as previously discussed.

Figures 21 through 24 are the 4400 Area Motor Pool three-dimensional fluorescence intensity modelling visualizations. Each figure represents one of four orientation planes and consists of representations showing both the highest and lowest fluorescence intensity levels for that orientation plane.

Four locations at the 4400 Area are identified as requiring further study. These are:

- a. The area immediately north of the cemetery near penetration 1207-01 and 1207-02. Possible surface contamination is present at this location.
- b. The location south of building 4468 and eastward toward penetration 1124-01.
- c. The location on the east side of 4400 Area near the McGuire AFB fence from penetration 1130-02 to 1203-03.
- d. The location between building 4431 and 4432 near penetrations 0116-01 and 0116-02.

5252 Boiler Plant

The Building 5252 Boiler Plant (Figure 25) is located at the intersection of South Scott Street and Maryland Avenue, near the Walson Army Hospital. This facility was constructed during the late 1960's to provide heating steam to the hospital and a nearby barracks complex. It is fueled by No. 6 fuel oil, stored in underground tanks on the east side of the building. One spill of 100 gal of No. 6 fuel oil was documented in 1990, and was cleaned up immediately.

Expected groundwater flow (based on previous studies and observations) is in a southwesterly direction. Local surface drainage moves in a westerly direction.

Five penetrations (1105-03 through 1106-02) were located near the north, west, and south perimeters of the building site. (Appendix E contains the data plates). No attempt was made to push on the east side due to underground utilities and mobility constraints. The maximum depth reached was 28 ft. Dense sand layers were encountered between 10 and 20 ft below ground surface. Some pushes were halted after 10 ft due to the dense sand. A higher variability in soil layering under this site was observed compared with the majority of the other sites visited.

No fluorescence above normal background intensity was observed at this site. The record for penetration 1106-02 shows a small increase in

fluorescence at approximately 1-ft depth, but this is due to light leaking into the sapphire window. Such leakage occurs at the surface during random pushes when the surface soil does not completely collapse around the push rod. This occurrence is immediately recognizable as being anomalous.

Three pushes at this site extended below the water table. Hydrocarbon contamination from a surface spill should have been distinguishable during these penetrations. No evidence of contamination was observed at this site, based on the laser-induced fluorometer response.

5326 Post Boiler Plant Area (Laundry)

The Post Laundry Boiler Plant (buildings 5324 and 5326) is located near the intersection of Reception Street and Wrightstown Road (Figure 26). It is a relatively modern facility constructed in 1974. The Boiler Plant supplies steam to the adjacent laundry, and the boilers are fueled by No. 4 fuel oil. The underground fuel tanks are located on the east and south sides of the Boiler Plant.

Two reported surface spills at the tank inlets released 30 gal of fuel oil between 1981 and 1987. A nearby surface drainage ditch was the potential receptor; surface water flow is to the east. Measured depth to the water table was 8 ft below ground surface. A 300-gal No. 4 fuel oil tank overflow was reported in 1987; approximately 3 dump truck loads of excavated soil were subsequently removed from the site.

Eight penetrations were completed at this site. Appendix F contains the data plates. The push points were located as closely as possible to the fuel tank inlets and adjacent to the drainage ditch.

Most of the fluorescence observed at the site would be classed as low-level responses (< 100 normalized counts). Only one horizon in 1117-02 showed pronounced fluorescence (600+ counts). The strongest signal was the peak at 7-ft depth. The readings from the cone and sleeve strain gauges and audible response suggest the penetrometer rod passed through an abandoned sewer pipe (not indicated on utility drawings).

Two soil and five groundwater samples were taken at this site. Water and soil samples were collected both from locations that showed fluorescence and those that did not. Table 8 summarizes the results of the analysis for TOC and TRPH. The water and soil samples collected at depths near a fluorescent horizon (depth of 30.8 ft) in penetration 1117-02 showed relatively higher levels of TOC. None of the samples showed elevated levels of TRPH and even the samples that showed fluorescence did not show levels of TRPH that were above the conventional detection limits for TRPH (2.2 - 2.7 ppm for water and 25 ppm for soils).

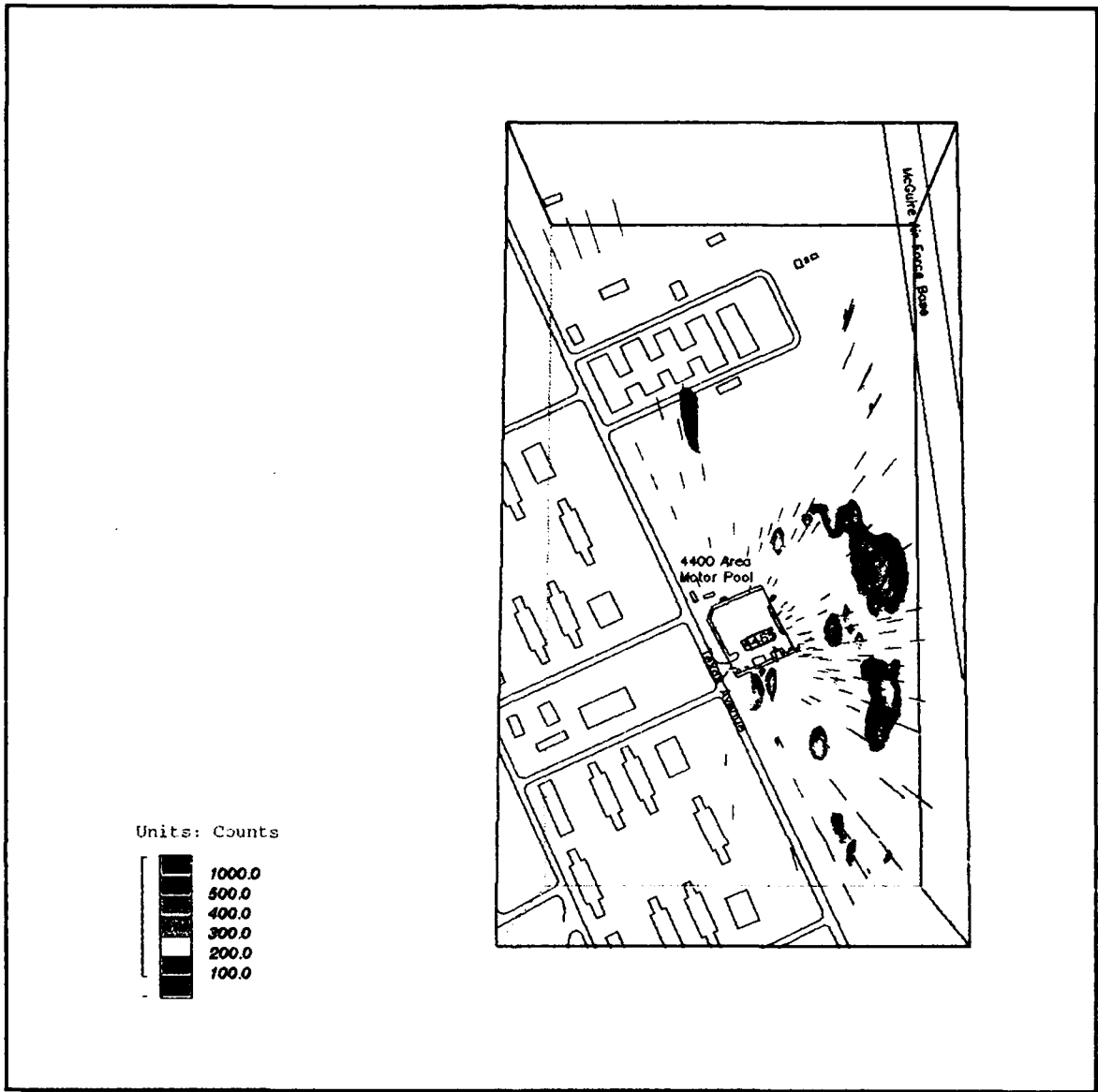

Figure 21a. 4400 Area Motor Pool 3-D visualization, view 1

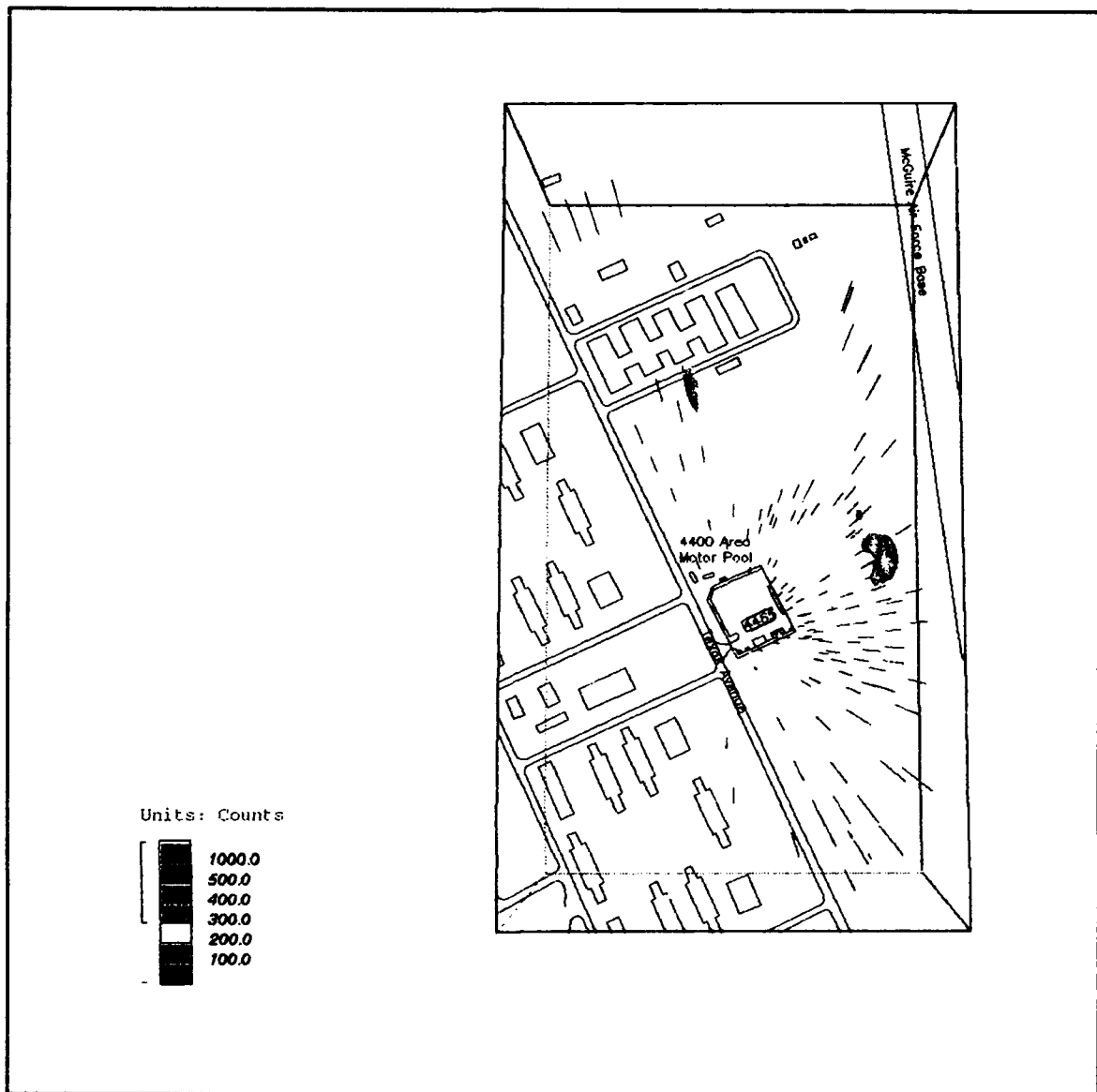

Figure 21b. 4400 Area Motor Pool 3-D visualization, view 1

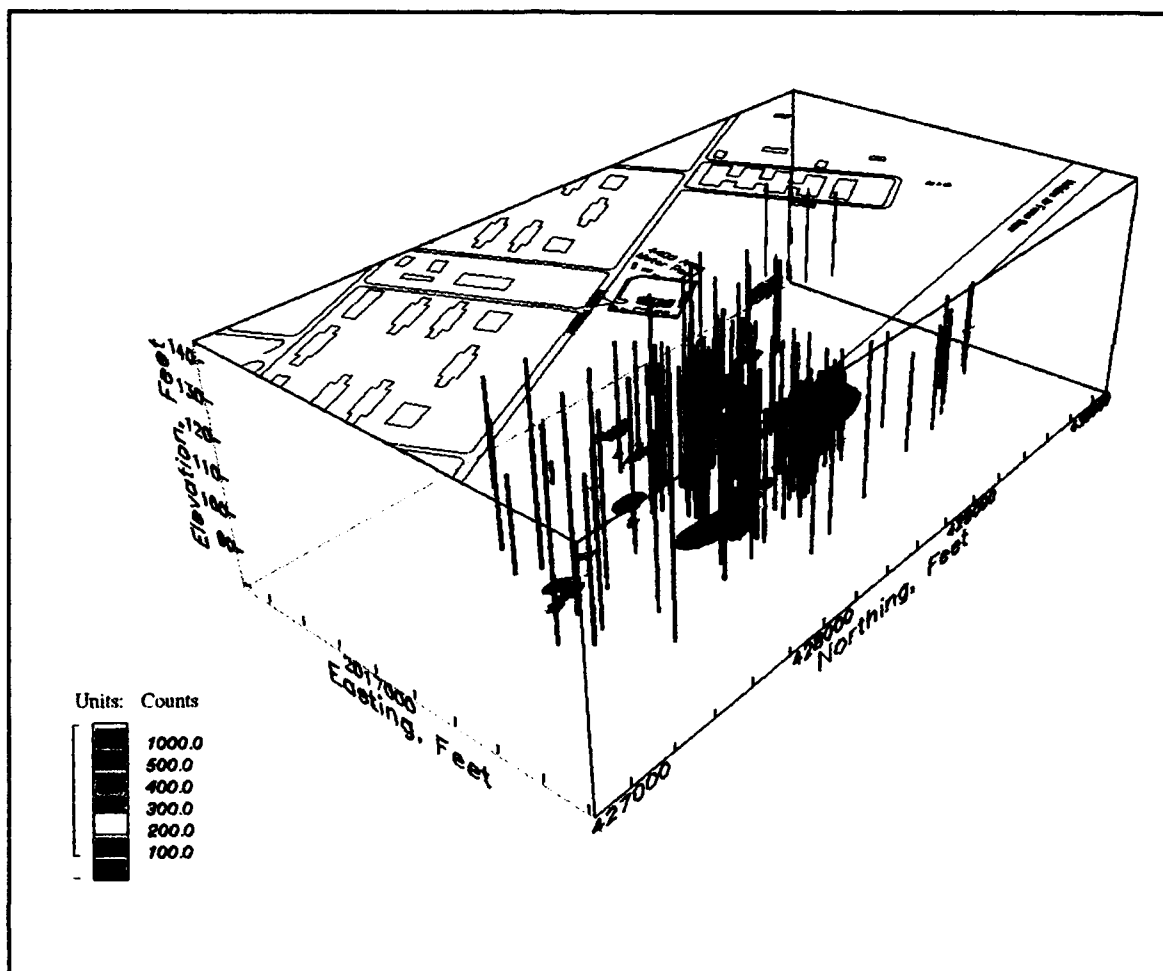

Figure 22a. 4400 Area Motor Pool 3-D visualization, view 2

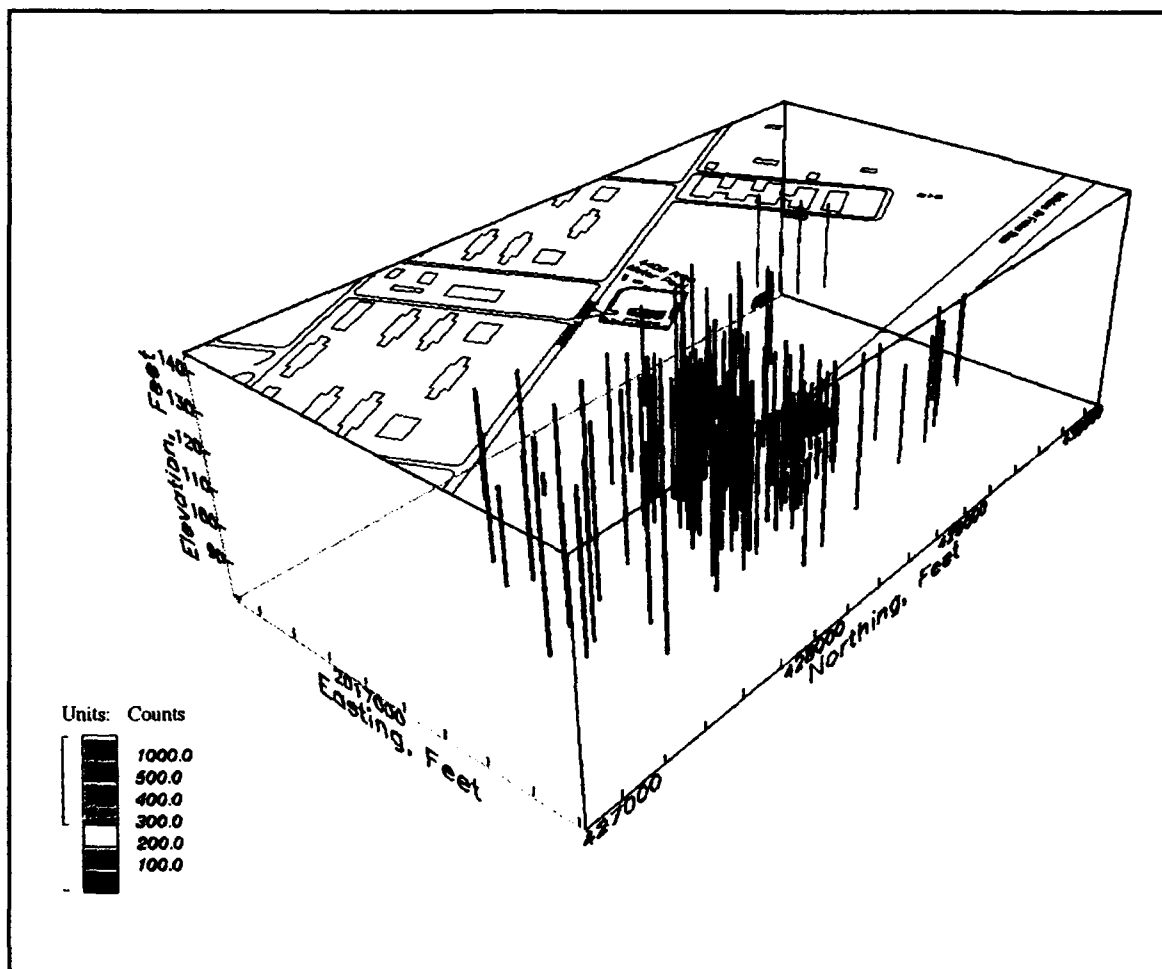

Figure 22b. 4400 Area Motor Pool 3-D visualization, view 2

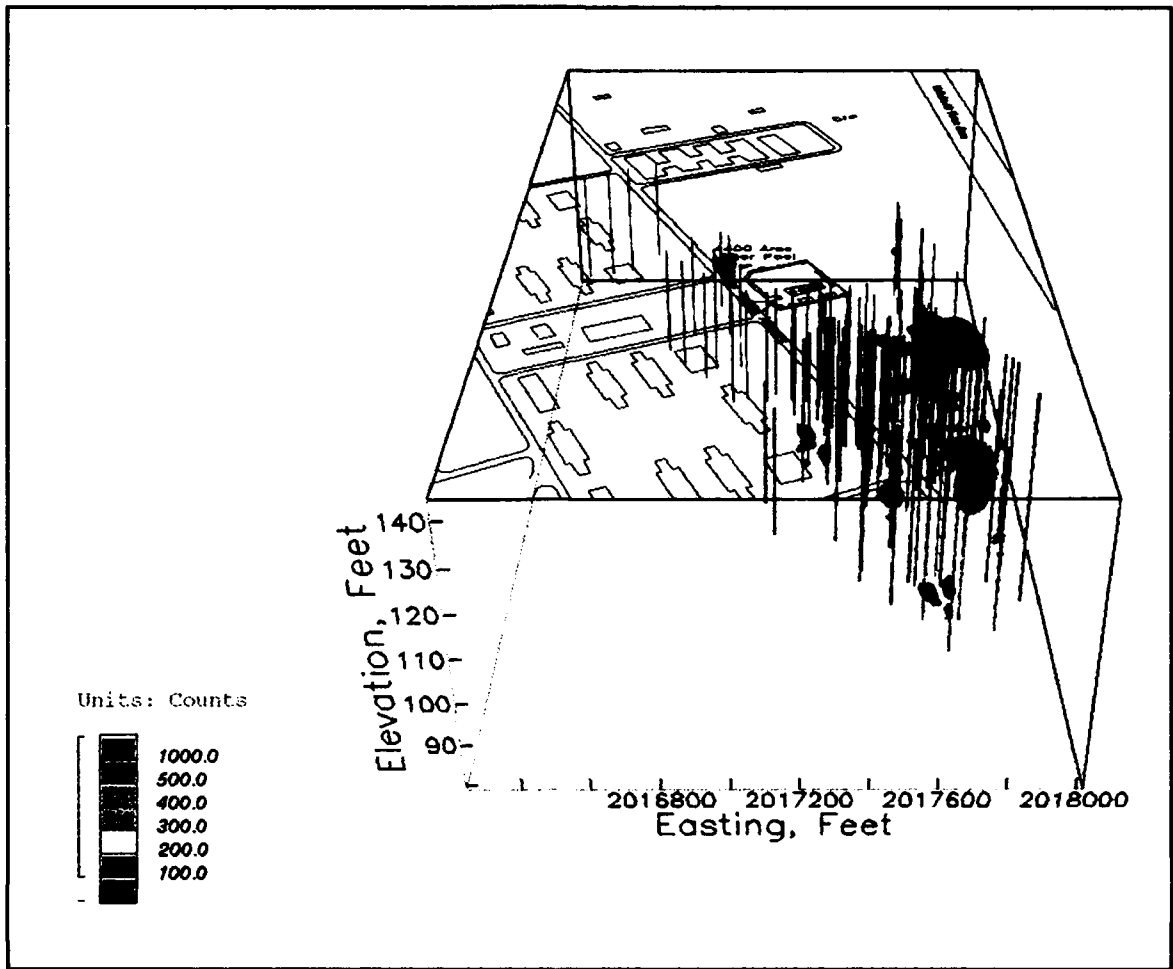

Figure 23a. 4400 Area Motor Pool 3-D visualization, view 3

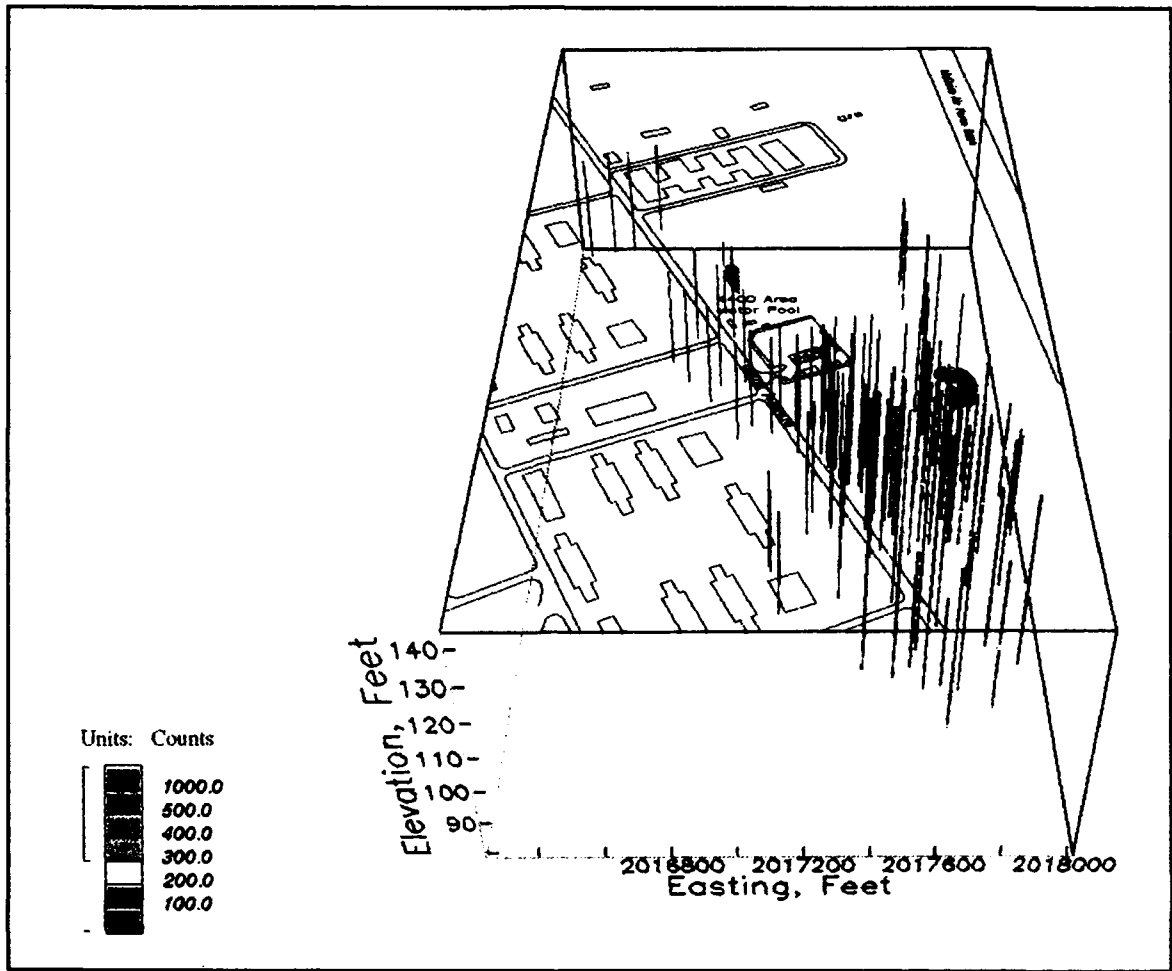

Figure 23b. 4400 Area Motor Pool 3-D visualization, view 3

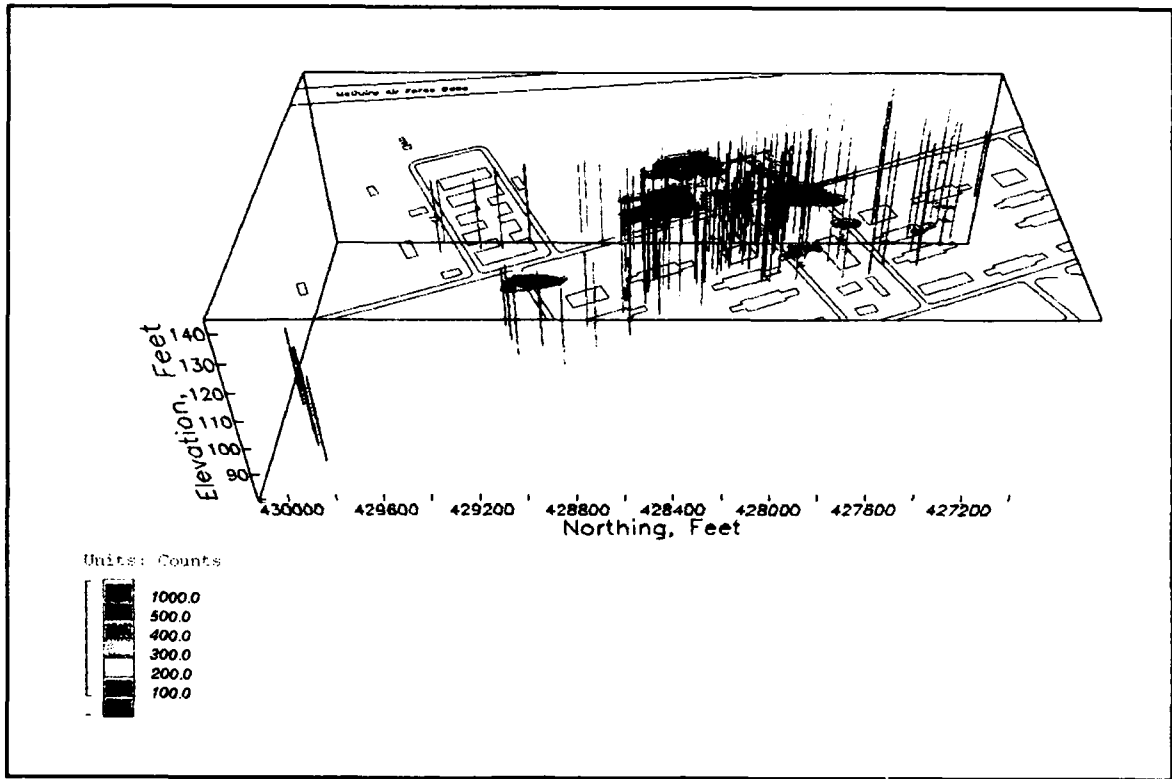

Figure 24a. 4400 Area Motor Pool 3-D visualization, view 4

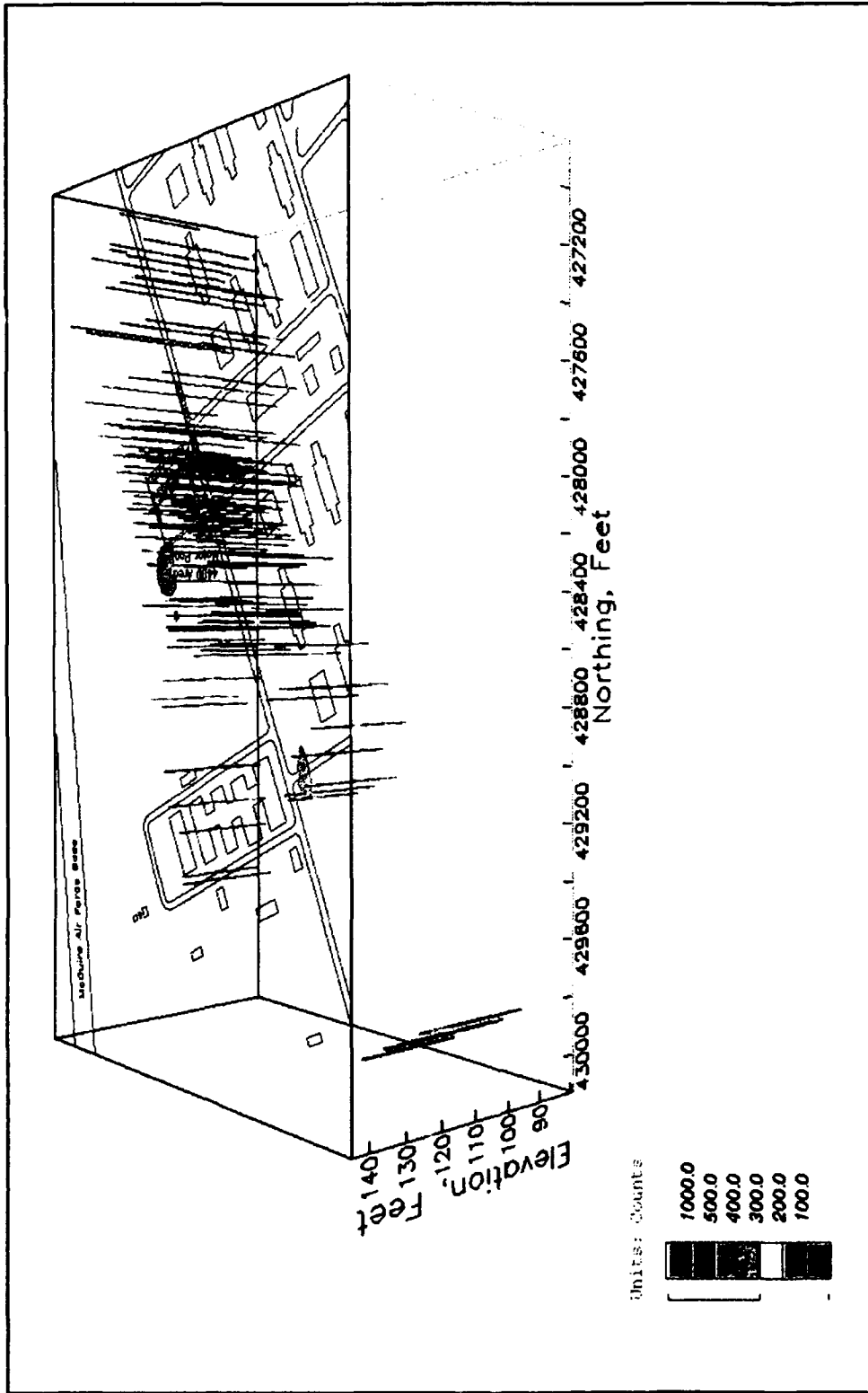

Figure 24b. 4400 Area Motor Pool 3-D visualization, view 4

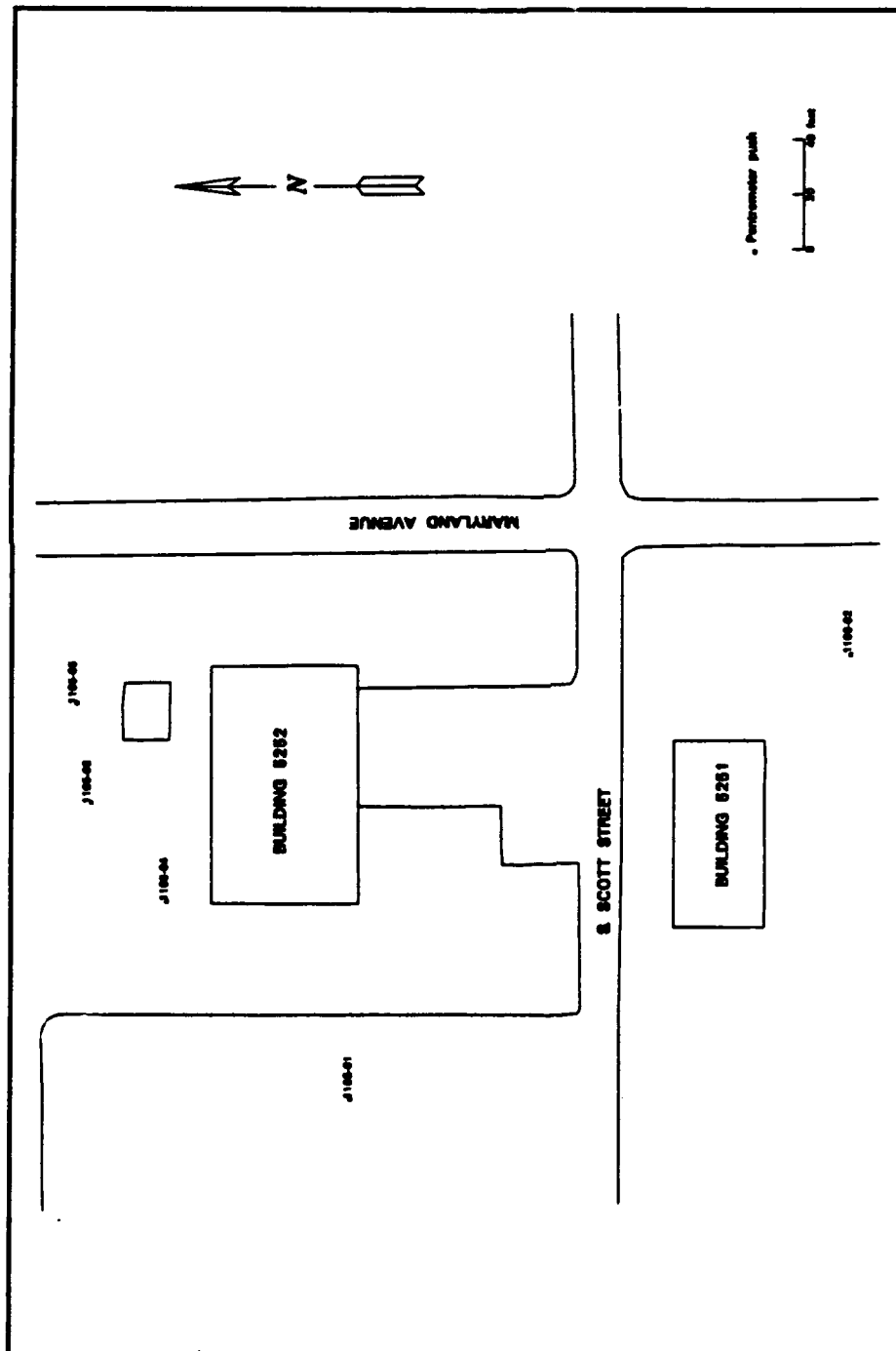

Figure 25. 5252 Boiler Plant site map

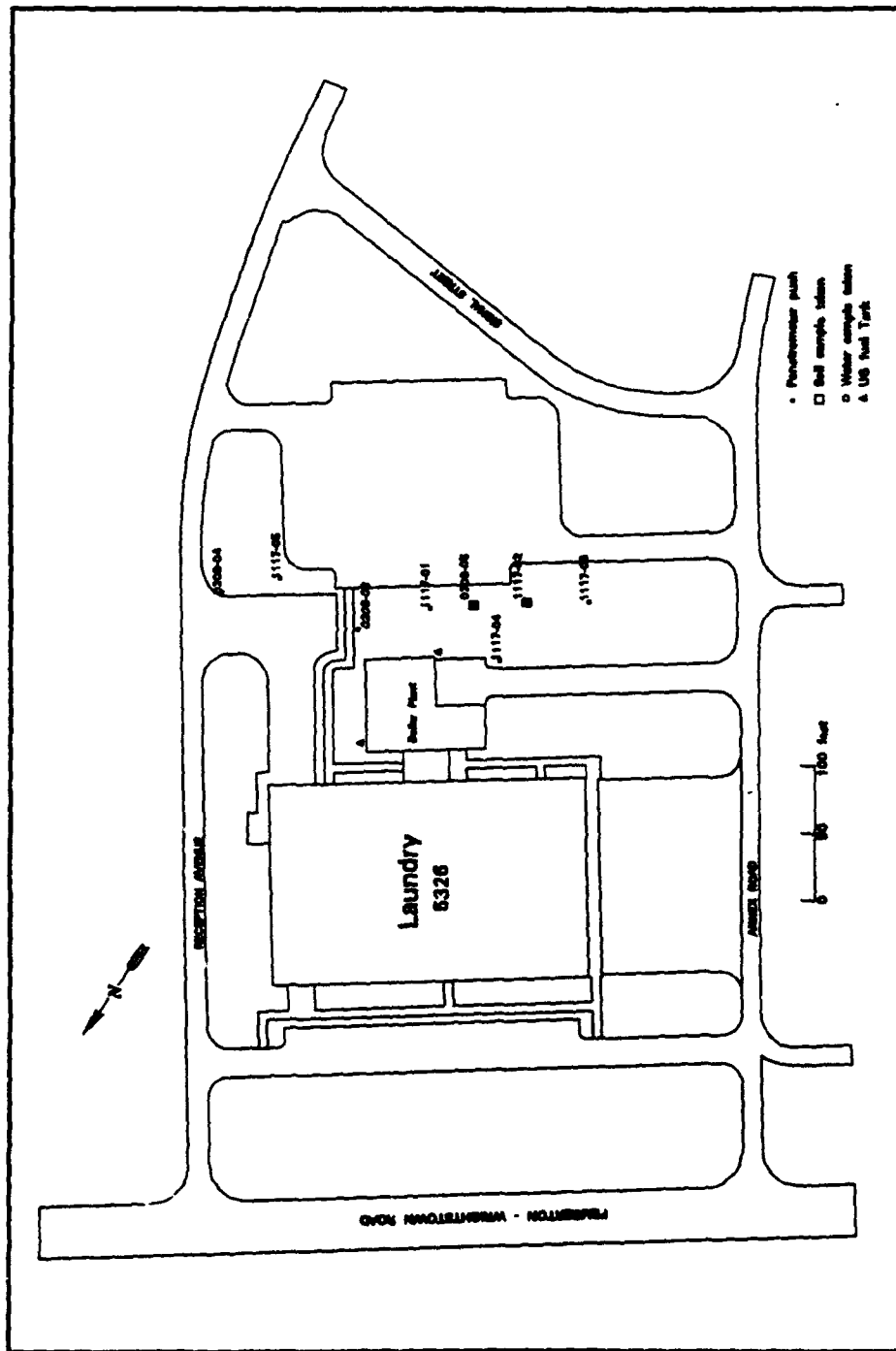

Figure 26. 5326 Post Boiler Plant Area (Laundry) site map

Table 8 Results of Laboratory Analysis for TOC and TRPH for the 5326 Post Boiler Plant Area (Laundry) Samples			
Sample No.	Total Organic Carbon ppm	Total Recoverable Petroleum Hydrocarbons ppm	Location/Type of Sample
29296	27.0	0.7	Taken from horizon showing no fluorescence water sample from near 0208-05, 20 ft BGS
29297	43.0	1.5	Taken from horizon showing no fluorescence water sample from near 0208-05, 20 ft BGS
29298	45.0	<2.4	Taken from horizon showing no fluorescence water sample from near 0208-05, 20 ft BGS
29295	479.5	<2.7	Taken from fluorescent horizon water sample near 1117-02 at depth of 31 ft below the surface
29299	34.0 ¹	<2.2	Taken from fluorescent horizon as second water sample near 1117-02 at depth of 31 ft
29282	1381.0	<25.0	Soil sample collected near 0208-05 at 1.0 ft depth, no fluorescence noted
29281	2778.0	<25.0	Soil sample collected near 1117-02 at 30.8 ft depth, fluorescence noted

¹ Sample was obtained by re-entering hole punched for sample 29295. Dilution of the pore water by drainage from uphole reduced concentration.

The penetration performed at 0208-05 showed no fluorescence peaks above approximately 50 counts. A verification sample of soil (collected at 2-ft depth) and one of groundwater (from 20.5-ft depth) taken near 0208-05 show no TRPH above the conventional limits of detection. Levels of TOC were low and ranged from 27 - 45 ppm.

A laboratory screening analysis for PAH compounds was undertaken and all of the results were below conventional detection limits for the compounds (Table 9). Appendix F contains details of the samples taken.

The fluorescence screening and the laboratory chemical analyses of samples do not indicate a widespread POL contamination. The TOC measurements made on water sample No. 29295 and the corresponding soil sample 29281, and the relatively low fluorescence intensities, indicate that organics, possibly degraded oil products (organic acids), are present on the site in the vicinity of 1117-02. The adjacent penetrometer pushes (1117-03, 1117-04, and 0208-05) show no evidence of fluorescence.

Table 9
Results of Laboratory Analysis for PAH Compounds for the
5326 Post Boiler Plant Area (Laundry) Samples

Analyte	Concentration, ppm	
	Sample No. 29518 ¹	Sample No. 29519 ²
Naphthalene	<0.86	<0.75
Acenaphthylene	<0.86	<0.75
Acenaphthene	<0.86	<0.75
Fluorene	<0.86	<0.75
Phenanthrene	<0.86	<0.75
Anthracene	<0.86	<0.75
Fluoranthene	<0.86	<0.75
Pyrene	<0.86	<0.75
Chrysene	<0.86	<0.75
Benzo(a) Anthracene	<0.86	<0.75
Benzo(k) Fluoranthene	<0.86	<0.75
Benzo(a) Pyrene	<0.86	<0.75
Indeno (1, 2, 3 - C, D) Pyrene	<0.86	<0.75
Benzo (G, H, I) Perylene	<0.86	<0.75

¹ Taken near 1117-02, 30.8-ft depth.
² Taken near 0208-05, 1-ft depth.

5426 Boiler Plant

Building 5426 Boiler Plant (Figure 27) is located at the intersection of Avenue C and South Scott Plaza. It consists of a boiler plant with three boilers fed by No. 6 Fuel Oil stored in outside above-ground tanks. One tank has a 500,000-gal capacity and is surrounded by a berm. The other tank is newer, holds 760,000 gal, and is also bermed. This plant is the largest of the four boiler plants supplying steam for the Cantonment area of Fort Dix, and was converted from a coal-powered plant during the early 1950's.

Eight fuel spills have been documented between 1982 and 1985, totaling 560 gal of fuel oil. Most of the spills were contained within the lined berms. Possible discharge to groundwater could have occurred but has not been verified, based on spill documentation. The site elevation gently dips toward Willows Pond, which is approximately 500 ft to the southeast of the plant. Probable local groundwater flow direction is to the southeast, toward the pond

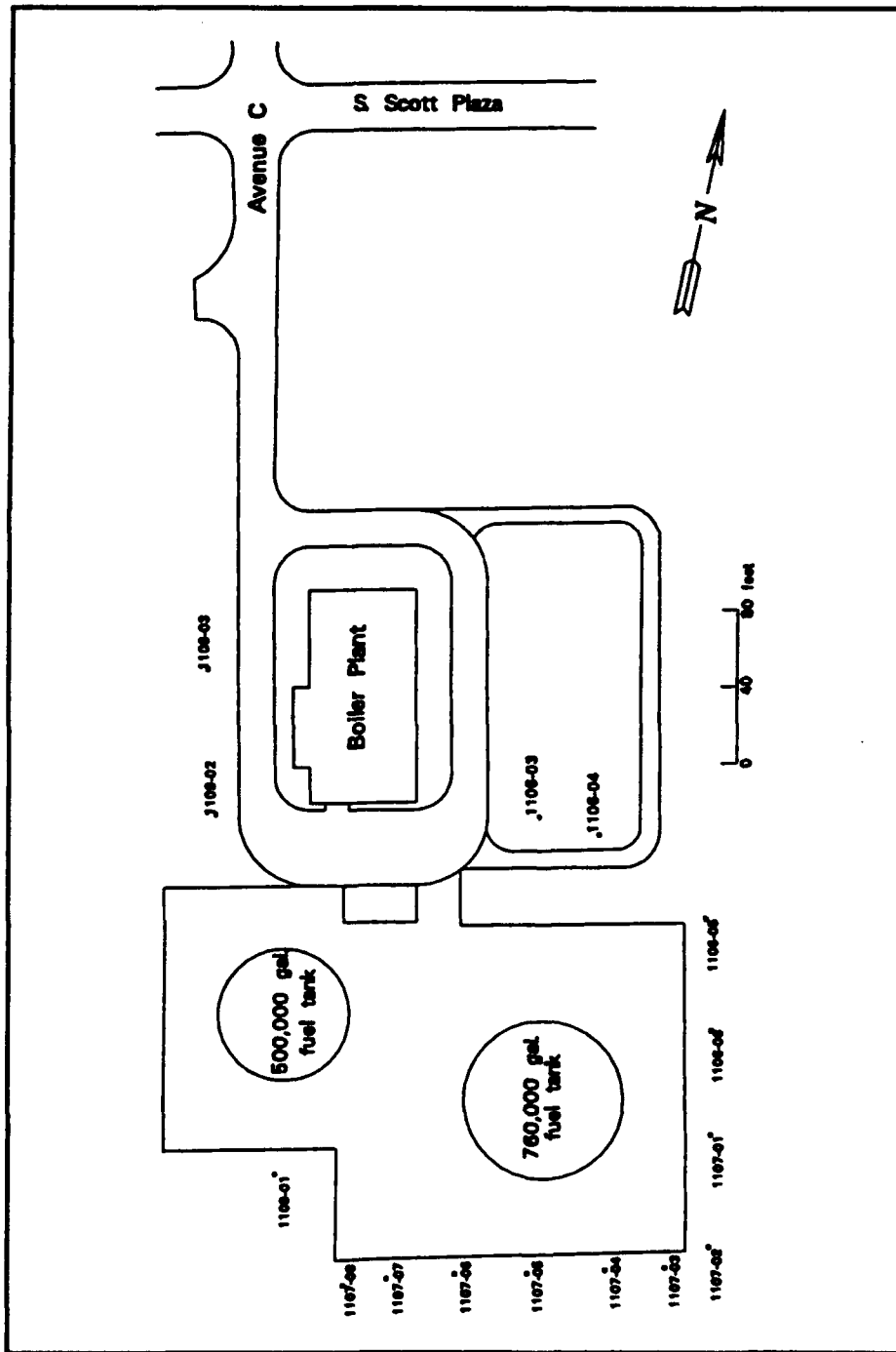

Figure 27. 5426 Boiler Plant site map

depression. Measured water table depth during the SCAPS visit was 18 ft below ground surface.

A total of 15 penetrations (1106-03 through 1109-03) were located around the perimeter of the plant and tank farm (Appendix G). Penetrations 1106-03 and 1106-04 were located adjacent to the fuel loading facility, at spots where the distressed grass cover indicated a possible spill. Typical depth of penetration was 30 ft below ground surface. A dense sand layer was encountered at approximately 7 ft below ground surface on most of the pushes; this layer was not encountered on push 1107-04. It was suspected that the soil at 1107-04 had been backfilled.

An Organic Vapor Analyzer (Century Model 128 Foxboro Co., Foxboro, Massachusetts) was utilized to "sniff" the holes after retraction of the push rods. No readings above a background value were observed.

No fluorescence above normal background levels was observed during any of the penetrations. Neither the soil gas measurements nor the in situ fluorescence showed POL contamination was present.

5700 Area Motor Pool

The 5700 Area Motor Pool (Figure 28) is located at the intersection of Fairfield Street and the Pemberton-Pointville Road. It consists of a fenced complex enclosing paved areas, a maintenance facility, two vehicle wash racks, an elevated vehicle service rack, and a fuel dispensing station with underground storage tanks. It was constructed during the early 1960's, and remains operational. Construction of a security fence a few feet north of the motor pool fence was ongoing at the time of the SCAPS visit. The barracks area north of the 5700 area is being modified as a federal prison.

Soil borings done in 1963 (from construction drawings on file) indicated a depth of 14 ft to the water table. At the time of the SCAPS visit, the water table surface was approximately 8 ft below ground surface. Probable groundwater flow direction is to the southeast.

Fourteen penetrations were completed at this site (Appendix H). Penetrations 1029-01 through 1029-04 were located 19 ft north of the motor pool fence (adjacent to the wash racks and fuel station). These locations were in the path of the future federal prison outer fence line. Penetration 1029-05 was located west of Erie Street on the east side of the motor pool. The first four penetrations went to approximately 20 ft below ground surface; a very dense soil layer was encountered at that depth and pushing beyond this depth was not attempted. No soil fluorescence above normal background was observed during any of these penetrations.

Penetrations 0125-02 through 0126-05 were conducted immediately south and southeast of the Motor Pool area, across Pointville Road and in the grass

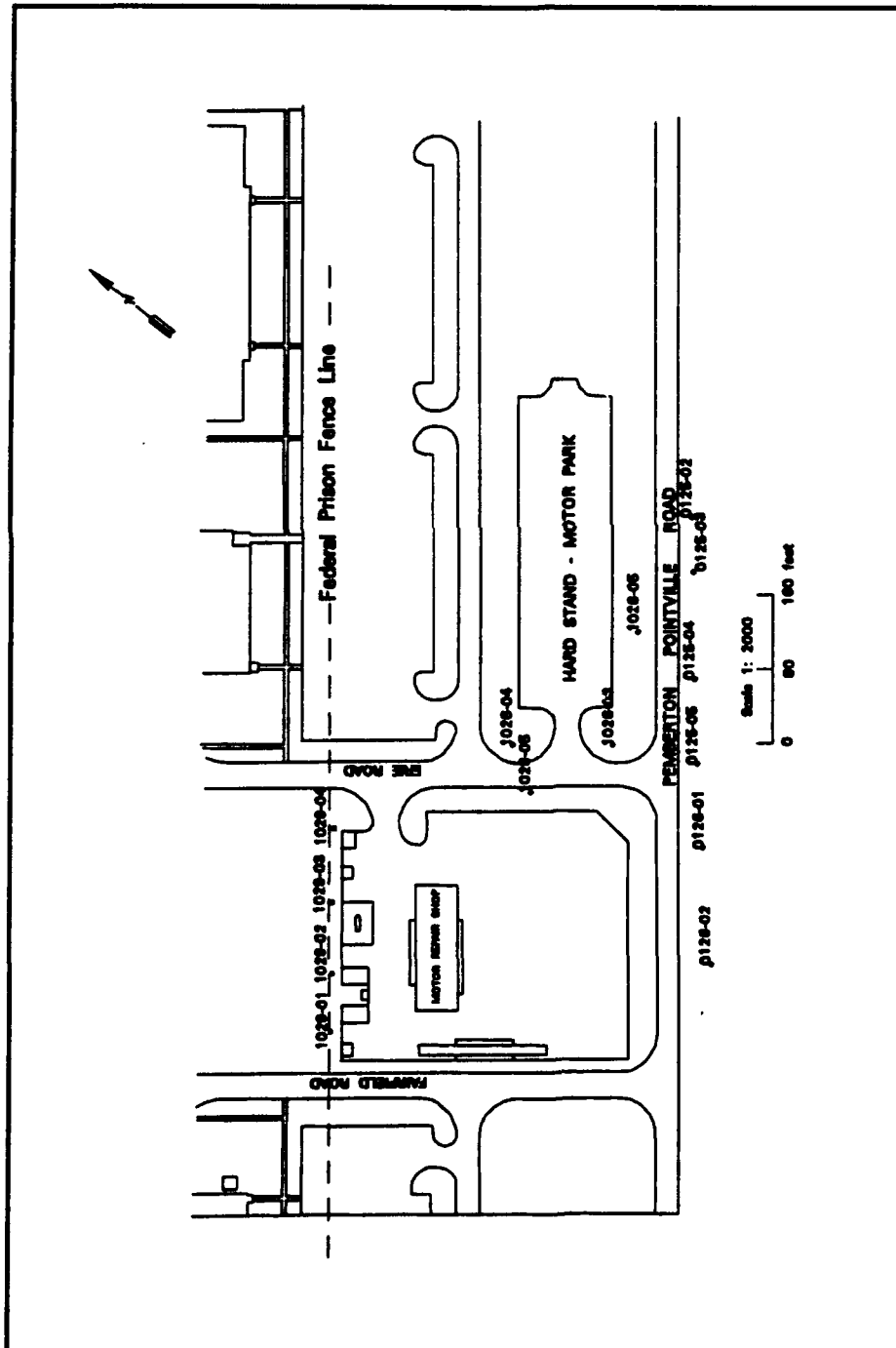

Figure 28. 5700 Area Motor Pool site map

medians. Slightly higher background fluorescence (up to 100 counts) was observed in the soil on the south shoulder of Pointville Road. Such elevated fluorescence response is inferred to be indicative of asphalt pavement construction hydrocarbon residue, including minor equipment fuel leakage spots. No evidence of POL contamination at the 5700 Area Motor Pool was indicated.

5800 Area Motor Pool

The 5800 Area Motor Pool (Figure 29) is located south of the intersection of New Jersey Avenue and West 17th Street, and is south of the 5900 Area. It consists of a maintenance shop, a fuel station, vehicle washracks, an oil/water separator, and an elevated vehicle rack. The facility was built in the 1960's. The surface elevation dips gently toward the south, and the probable groundwater flow is in a southerly direction (toward buildings 5881 and 5891).

A 10-gal diesel fuel spill was reported in 1987, and the contaminated soils were immediately excavated. The Duck Pond south of the Incinerator Building 5891 was the potential receptor of contaminated groundwater that might have occurred from this event (USATHAMA 1992).

Seventeen penetrations were completed around the perimeter fence at the Motor Pool (Appendix I). The majority of the penetrations were to a depth of 30 ft below ground surface or to refusal (penetrations 0128-03 and 0127-05 were aborted due to an unknown underground obstacle).

Fluorescence (< 100 counts) was observed at locations on the west side of the Motor Pool (penetrations 0129-03 through 0129-05). Soil samples were taken adjacent to penetration 0129-05. Relatively high TOC levels were noted in both soil samples from the 5800 Area Motor Pool but no significant TRPH or PAH concentrations were detected in any samples (Tables 10 and 11). Fluorescence in the coarse material (gravel particles) was observed in penetration 0129-05 at a depth of 9 ft at a wavelength of 520 nm. The soil sample taken at that depth did not contain significant TRPH or PAH concentrations. X-ray diffraction was used to establish the mineralogy of the fluorescing granules in the coarse fraction of the soil. Examination with a petrographic microscope was also undertaken to confirm the x-ray results. The granules were quartzite rock. The predominant mineral in the soil particles was determined to be quartz (Figure 30). Trace amounts of sillimanite, hematite, and zircon were also observed. Under ultraviolet light, the lab specimens fluoresced with a visible blue color. Figure 31 shows the spectra obtained from non-fluorescing soil, soil containing the fluorescent mineral granules, and a separate quartzite granule. The maximum fluorescence (325 counts) measured on the single granule centered at 440 nm, while the maximum fluorescence (150) from the mineral mixture in the soil was near 500 nm.

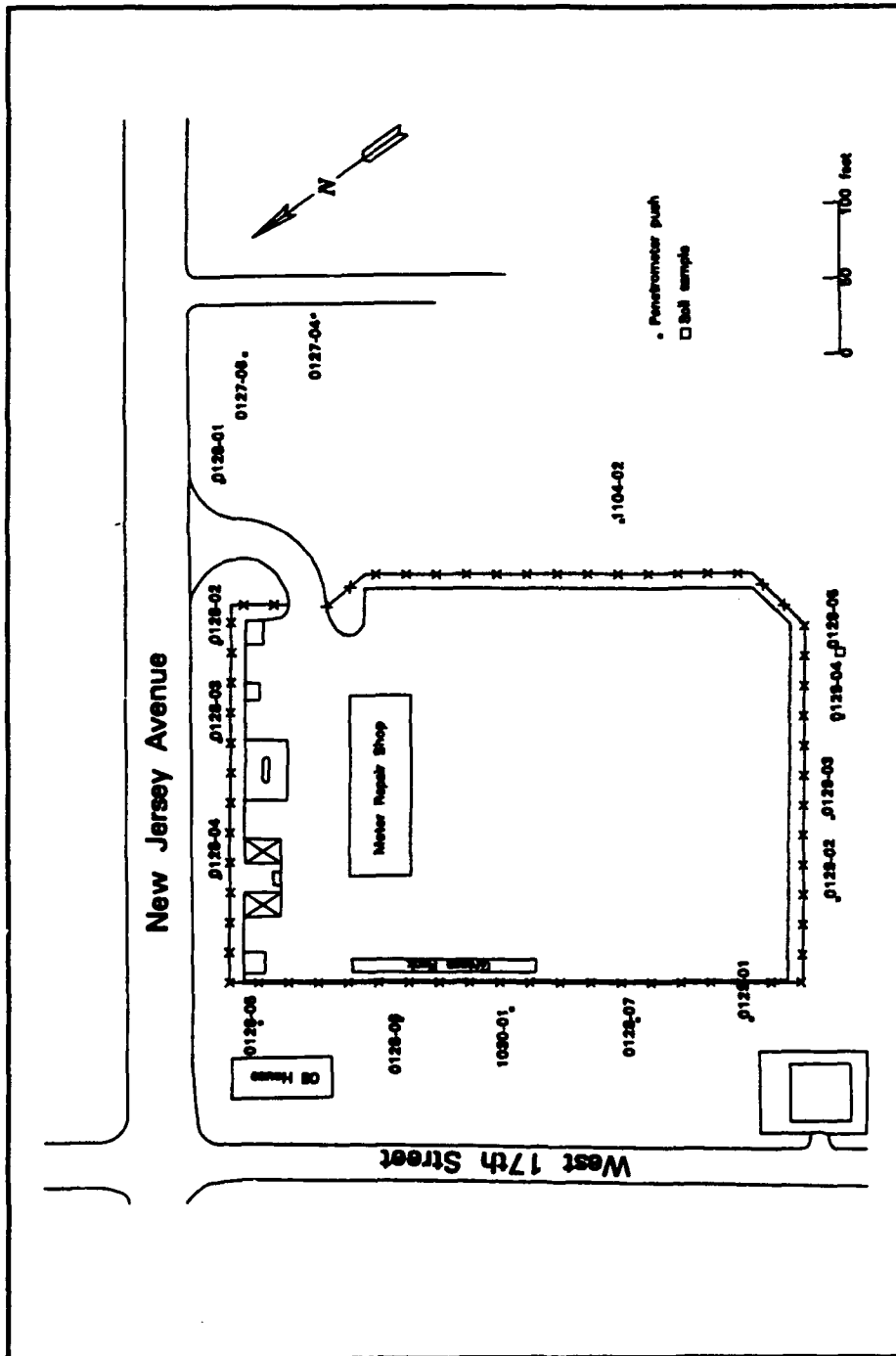

Figure 29. 5800 Area Motor Pool site map

Table 10
Results of Laboratory Analysis for TOC and TRPH for the 5800
Area Motor Pool Samples

Sample No.	Total Organic Carbon ppm	Total Recoverable Petroleum Hydrocarbons ppm	Location
29286 (Soil)	1905	<25.0	Next to 0129-05, 3 ft BGS no fluorescence noted
29284 (Soil)	1347	<25.0	Next to 0129-05, 9 ft BGS soil fluoresces

Table 11
Results of Laboratory Analysis for PAH Compounds for the 5800
Area Motor Pool Samples

Analyte	Concentration, ppm	
	Sample No. 29521 ¹	Sample No. 29523 ²
Naphthalene	<0.69	<0.95
Acenaphthylene	<0.69	<0.95
Acenaphthene	<0.69	<0.95
Fluorene	<0.69	<0.95
Phenanthrene	<0.69	<0.95
Anthracene	<0.69	<0.95
Fluoranthene	<0.69	<0.95
Pyrene	<0.69	<0.95
Chrysene	<0.69	<0.95
Benzo(a) Anthracene	<0.69	<0.95
Benzo(k) Fluoranthene	<0.69	<0.95
Benzo(a) Pyrene	<0.69	<0.95
Indeno (1, 2, 3 - C, D) Pyrene	<0.69	<0.95
Benzo (G, H, I) Perylene	<0.69	<0.95

¹ Taken from sample No. 29284.
² Taken from sample No. 29286.

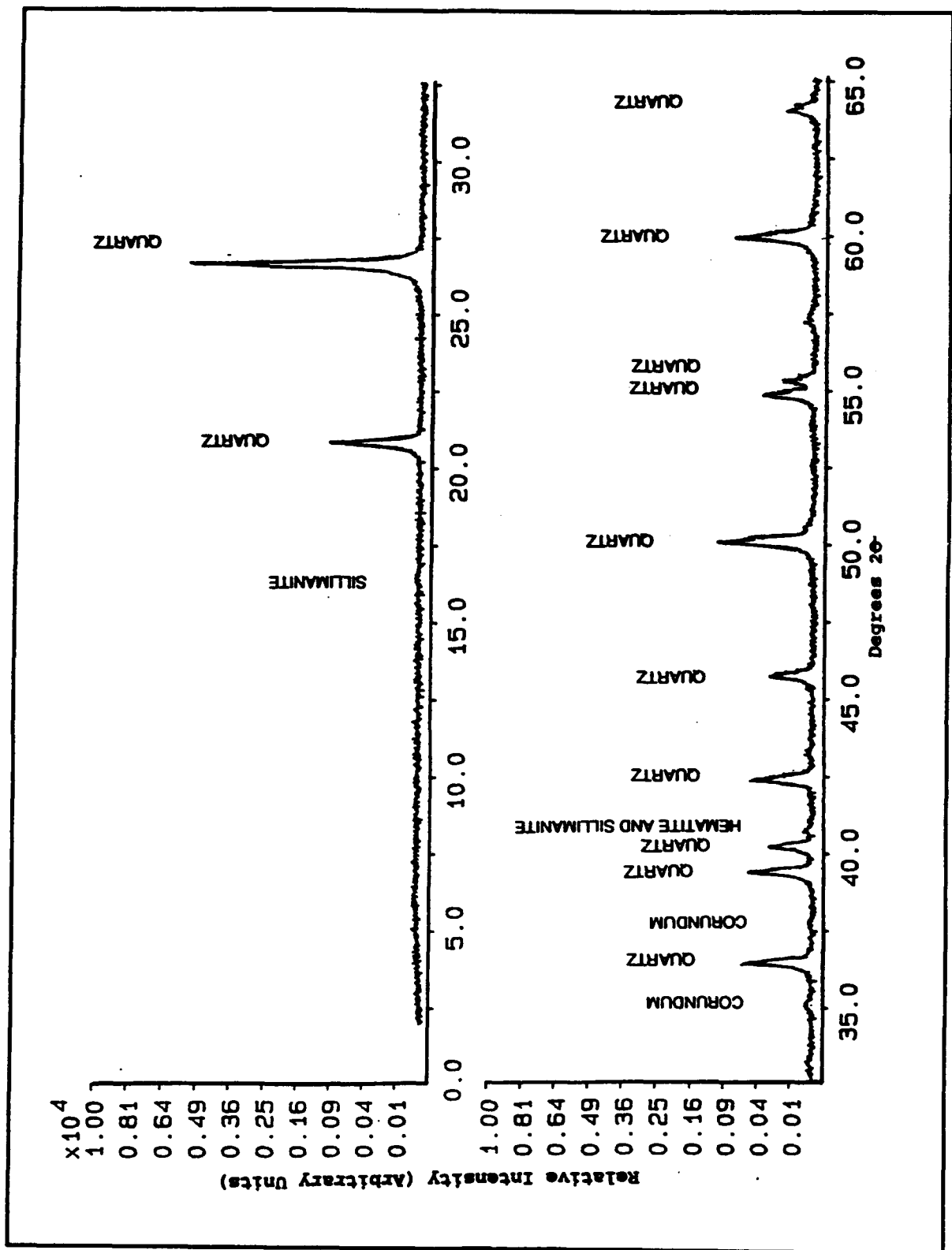

Figure 30. X-ray diffraction pattern from fluorescent mineral grains

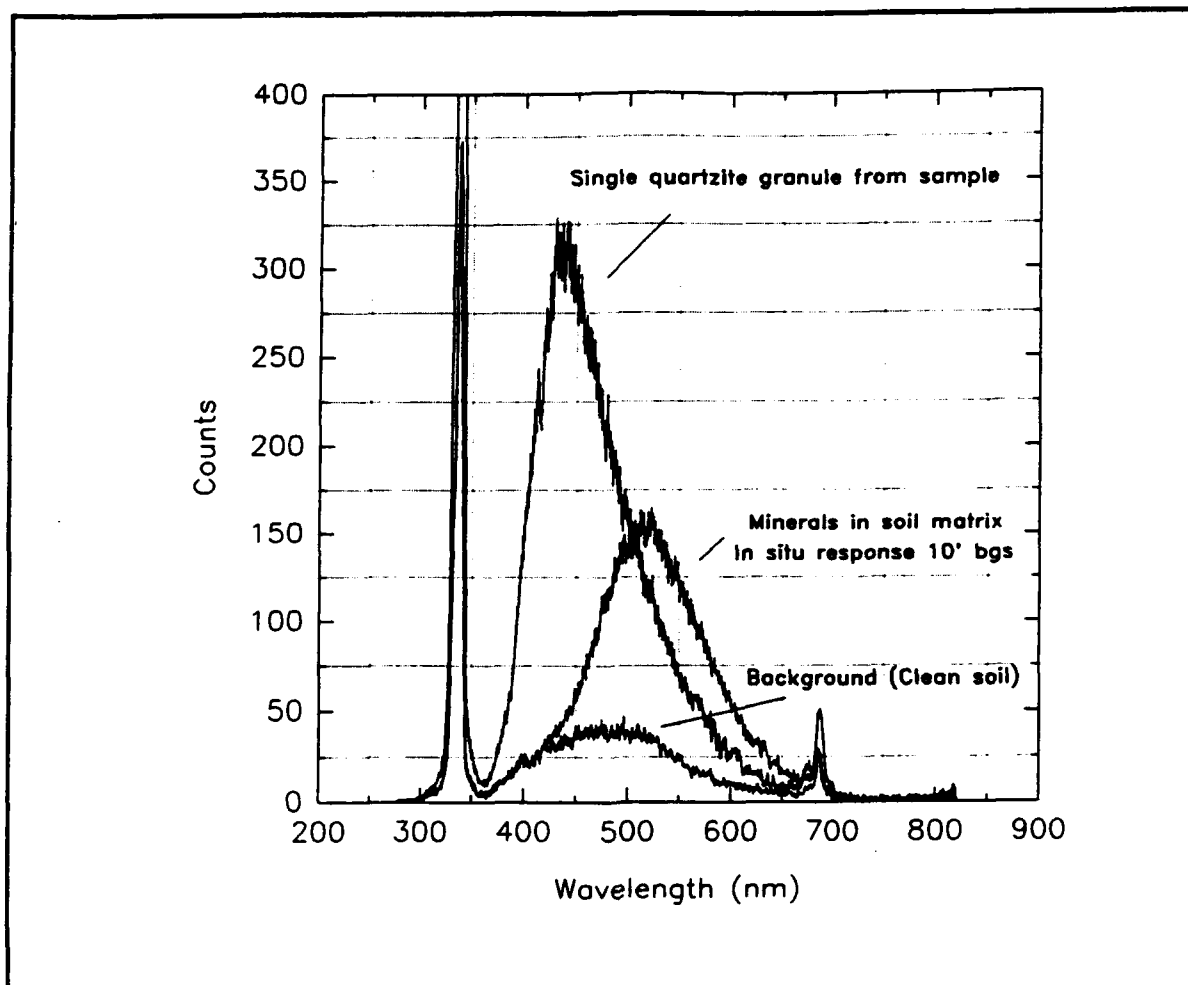

Figure 31. Fluorescent spectra

Pure quartz typically does not fluoresce but varieties containing trace metals can fluoresce from blue-white to purple (Dake 1953). The longer wavelength fluorescence may be caused by other varieties of quartz or other mineral species the fluorometer encountered in this soil layer. The presence of fluorescent minerals in the absence of hydrocarbons and PAH compounds indicate the fluorescence observed is not related to POL contamination.

Penetrations 0127-04 and 0127-06 also indicate fluorescence (less than 100 counts), but at a lower wavelength (<500 nm). Such a signature suggests that hydrocarbon contamination may be present approximately 5 ft below ground surface (in a 1 ft thick soil lens) at these locations. No similar pattern was observed at any other location in this area.

5881 Boiler Plant and Incinerator

The 5881 Boiler Plant (Figure 32) is located immediately south of the 5800 Area Motor Pool. The Incinerator (Resource Recovery Facility 5891) is located approximately 100 ft southeast of the 5881 Boiler Plant. Both facilities share common pavement areas, and the incinerator supplies steam to the boiler plant for supplemental steam during peak heating demands. The boiler plant was constructed in the 1950's and was originally fueled by coal. Number 6 fuel oil is presently used as fuel, and a storage tank has since been added where the coal storage yard used to be located. The Incinerator utilizes municipal and dry industrial wastes as fuel. Underground utilities are numerous at this site.

Fourteen fuel oil spills have been documented as occurring between 1980 and 1984. Minimum estimates indicate the spills released 1,488 gal of fuel oil onto the site. The potential receptor was the Duck Pond located to the south; probable groundwater flow is in a southerly direction (ICF Kaiser 1992).

A hilly wooded area is located to the south and west of the complex. The physiography surrounding this site is unique for the sites visited at Fort Dix; it consists of deeply eroded ravines covered with trees and vegetation similar to a typical eastern hardwood forest. The surface drainage feeding into the Duck Pond follows a relatively narrow streambed between the steep hillsides. Truck access to the alluvial streambed was not possible due to the steep topography.

Fourteen penetrations were completed where accessibility permitted around the perimeter of buildings 5881 and 5891 (Appendix J). Fluorescence (< 100 counts) was noted during penetrations 1104-03 (33-ft depth) and 1104-04 (27-ft depth), which were located between buildings 5881 and 5891. Penetrations 0208-01 and 0208-02 were located as closely as possible to the previous penetrations (1104-03 and 1104-04) to determine if a contaminant pattern had developed; hydraulic ram refusal occurred at 10 ft and 12 ft, respectively. Neither penetration reached the fluorescent horizon seen in 1104-03 and 1104-04. The fluorescence appeared in a soil zone with an average thickness of 1 ft.

Penetrations 0126-06, 0126-07, 0127-01 through 0127-03, and 0127-07 were located in a wooded area approximately 200 ft southeast of the Incinerator Building 5891 and immediately south of a steep ravine. Fluorescence (< 100 counts) was observed during these penetrations, but the reflectance wavelengths were greater than 500 nm (atypical of POL product signatures). The presence of an old landfill or backfilled debris, approximately 6 ft below ground surface, is evidenced by the soil strength response of the cone and sleeve, and from visual clues.

A sample was taken near penetration 0201-03 to examine the spectral character of the fluorescence observed in that penetration. Tables 12 and 13 summarize the analytical results for TOC, TRPH, and PAH values. The TRPH concentration was less than 24 ppm and the PAH concentrations

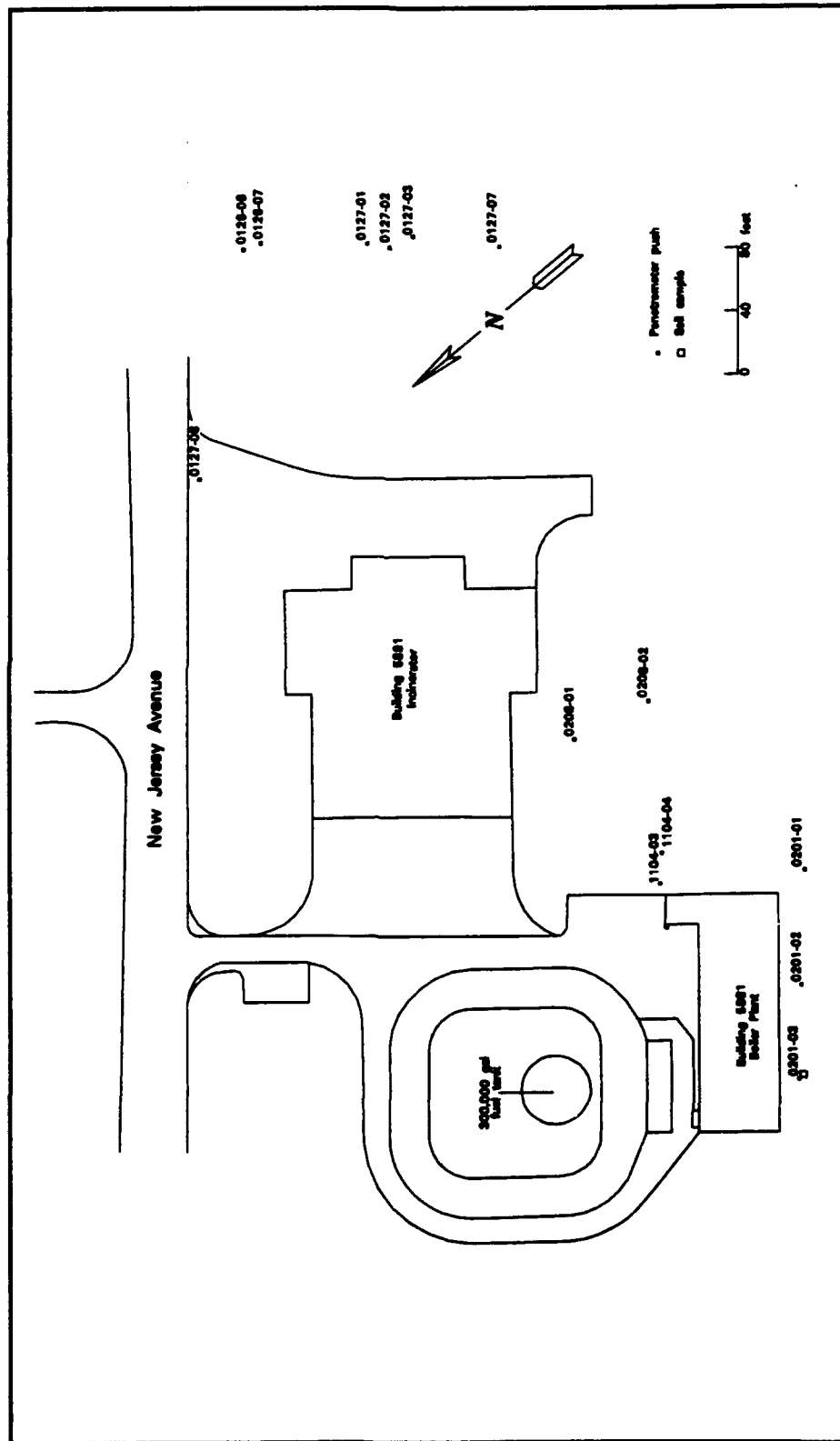

Figure 32. 5881 Boiler Plant and Incinerator site map

Table 12
Results of Laboratory Analysis for TOC and TRPH for the 5881
Boiler Plant Samples

Sample No.	Total Organic Carbon ppm	Total Recoverable Petroleum Hydrocarbons ppm	Location
29285 (Soil)	1720	<25.0	Next to 0201-03, 10 ft BGS Mineral fluorescence noted.

Table 13
Results of Laboratory Analysis for PAH Compounds for the 5881
Boiler Plant Samples

Analyte	Concentration, ppm
	Sample No. 29517 ¹
Naphthalene	<0.71
Acenaphthylene	<0.71
Acenaphthene	<0.71
Fluorene	<0.71
Phenanthrene	<0.71
Anthracene	<0.71
Fluoranthene	<0.71
Pyrene	<0.71
Chrysene	<0.71
Benzo(a) Anthracene	<0.71
Benzo(k) Fluoranthene	<0.71
Benzo(a) Pyrene	<0.71
Indeno (1, 2, 3 - C, D) Pyrene	<0.71
Benzo (G, H, I) Perylene	<0.71

¹ Taken from sample No. 29285.

observed were less than 0.71 ppm. Detailed sample information is given in Appendix J.

The soil samples were examined using x-ray diffraction and petrography in a manner identical to that used with samples taken from the 5800 Area Motor Pool site (located approximately 250 ft northwest). The same mineral fluorescence noted in the soil samples from 5880 site was noted in the sample from 5881 site.

Based on the fluorescence spectral patterns and lab analysis, fluorescence response, observed in penetrations 0126-06 through 0127-02, 0127-07, and 0201-01 through 0208-02, is a function of mineralogical composition.

The two penetrations between buildings 5881 and 5891 (1104-03 and 1104-04) indicate fluorescence responses at wavelengths lower than those observed in the above-listed penetrations. The fluorescence response was exhibited in finer-grained soil layer less than 5 ft thick, and could possibly indicate evidence of contamination. Mineralogical composition interference does not appear in these two penetrations. No evidence of any "plume" pattern was detected, based on the penetrations performed in this area; evidence of hydrocarbon contamination exists at penetrations 1104-03 and 1104-04. Further investigations within this area just off the pavement may be warranted.

5900 Area Motor Pool

The 5900 Area Motor Pool (Figure 33) is located north of the intersection of New Jersey Avenue and West 17th Street. It consists of a large fenced area enclosing maintenance shops, fuel stations, elevated vehicle racks, oil/water separators, and wash racks. The facility was built in the mid-1960's, and total surface area is approximately 10 acres. The area is bounded by woods along the north and west sides, and surface elevation gently dips in a southerly direction. Approximate depth to water table was 15 ft, and the probable groundwater flow direction is to the south. A 30-gal POL release was reported in 1989; remedial cleanup action was immediately taken.

Penetrations 1030-02 through 1104-01 (18 total) were located along the north, west, and south perimeter of the 5900 Area (Appendix K). No penetrations were attempted on the east side due to the presence of underground utilities and lack of accessibility. Typical depth of penetration was 20 ft below ground surface; a very dense sandy soil layer encountered at that approximate depth prevented deeper penetration. Penetration 1102-02 was aborted due to an accidental equipment shut-off; no data was archived for this event.

No fluorescence activity above normal background levels was observed at this site.

8100 Area Motor Pool

The 8100 Area Motor Pool (Figure 34) is located in the training area at the intersection of Range Road and 80th Street, on the north side of Range Road. Building 8132 is approximately 200 ft west, across Range Road. This area includes several full-service motor pools and vehicle service areas. The motor pools contain maintenance areas, solvent recovery systems, vehicle washracks,

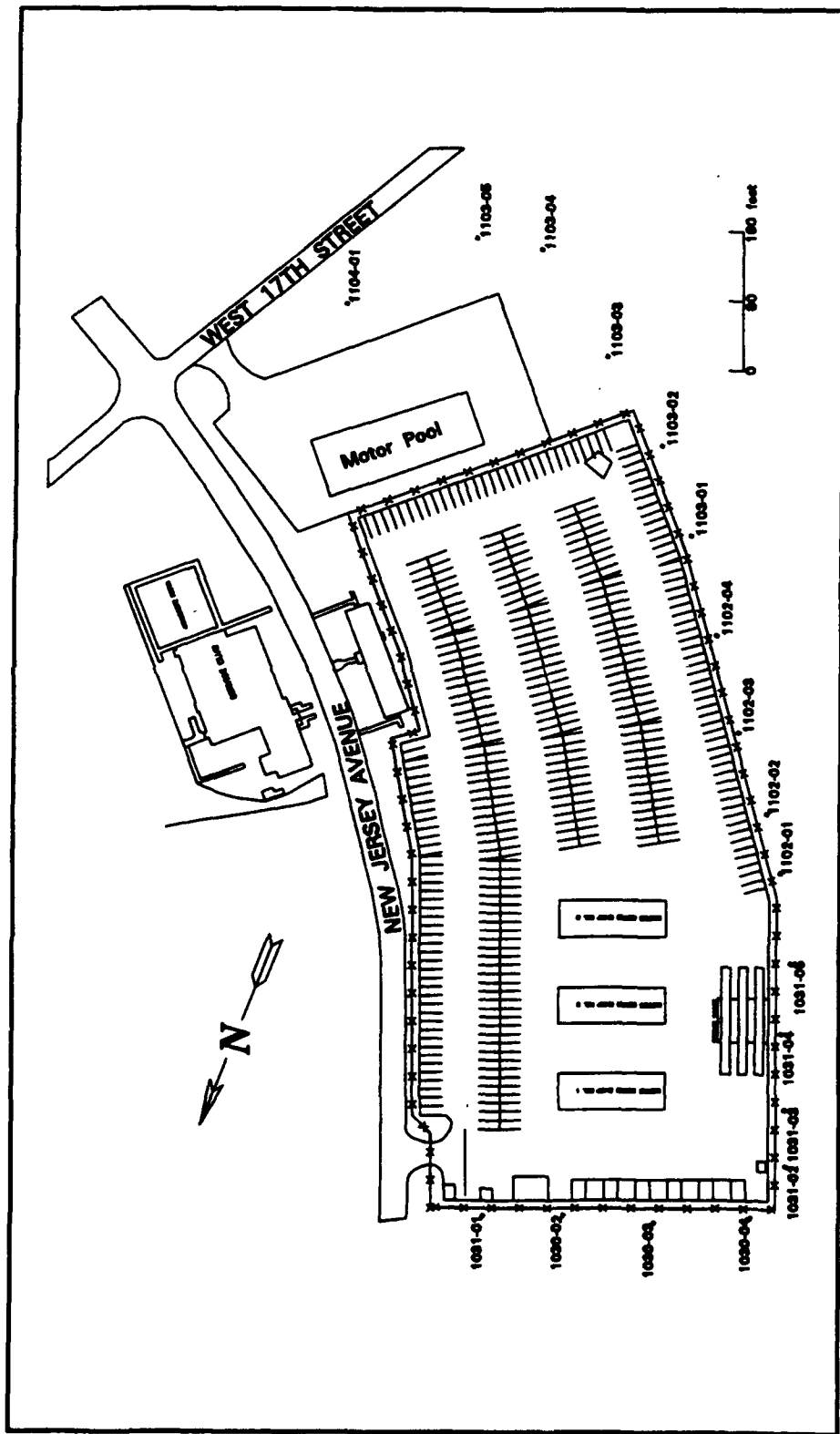

Figure 33. 5900 Area Motor Pool site map

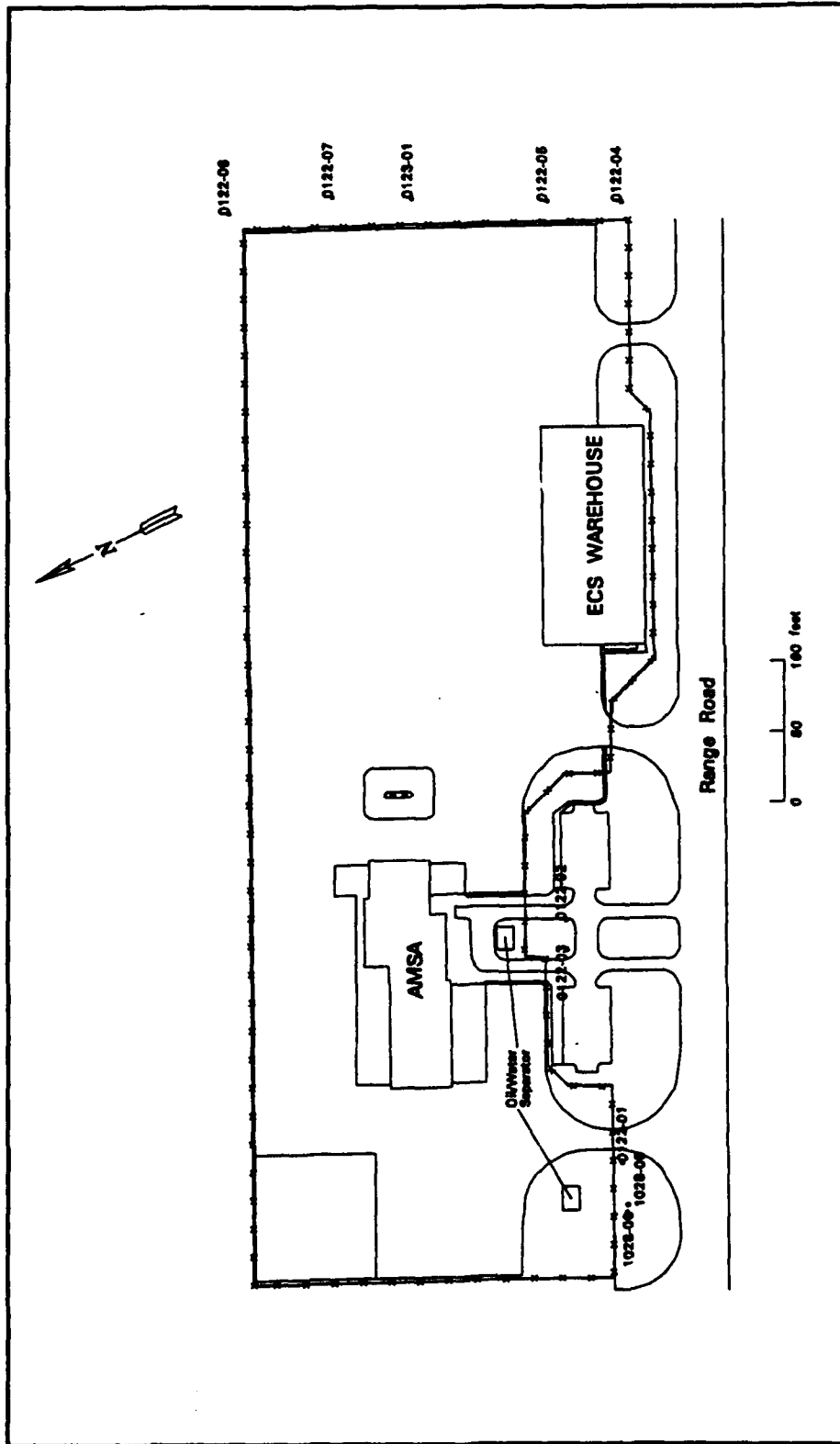

Figure 34. 8100 Area Motor Pool site map

oil/water separators, and underground storage tanks. The fenced complex of the 8100 Motor Pool has been constructed within the last 6 years (1987); it is a relatively new facility. The entire site is relatively flat, and is surrounded by drainage ditches. Catch basins and drainage structures intercept the surface flow from the pavement areas within the fenced complex. Probable groundwater flow direction is to the southeast. No POL releases to soil, surface water, or groundwater have been reported.

The areas of concern for SCAPS investigations were the oil/water separators adjacent to Range Road and the downgradient perimeter (southeast side) between the PBAS 83 Basin and 85th Street (off the right side of the Figure 34 site map). Due to the relatively high water table (approximately 8 ft below ground surface) the penetration depths were less than 30 ft below ground surface.

Ten penetrations were completed at this site (Appendix L). Penetrations 1028-05 and 1028-06 were located 10 ft from the fence, approximately 20 ft south of an oil/water separator. The fluorescence observed in the top 4 ft of penetration 1028-05 was found to be spurious. O-ring lubricant had been liberally placed on the O-rings located below the fluorometer window and the oil had coated the soil in front of the fiber optic window. The O-ring lubricant was changed to a non-fluorescent brand, and the adjacent penetration 1028-06 confirmed that the lubricant had caused the problem. The old O-ring lubricant was confirmed as not affecting data on previous penetrations (conducted at building 8132).

Penetrations 0122-01 through 0123-01 (a total of 8 penetrations) were conducted adjacent to the two oil/water separators on the south side and the grassed area between the east fence and 85th Street. Typical depth was 30 ft below ground surface, and no fluorescence behavior above normal background level was observed. No soil samples were collected.

Based on the absence of observed fluorescence activity from the number of penetrations performed around the 8100 Area Motor Pool, no evidence of hydrocarbon contamination was detected in either the soil or groundwater.

8132 Hazardous Waste Storage Area

The Hazardous Waste Storage Area (Figure 35) is located south of the intersection of Range Road and 80th Street, and consists of a single story brick building surrounded by new asphalt pavement. The 8100 Area Motor Pool is located approximately 200 ft northeast, across Range Road. A chain link fence surrounds the pavement area, and a cleared perimeter between the fence line and tree line surrounds the site on three sides. Waste drums are stored inside the fenced site. Surface water runoff flows to a low point in the pavement on the south side; the pavement is curbed around its perimeter. The ground surface outside the fence is generally flat. The ground surface on the south side of the facility has the lowest elevation and receives the surface

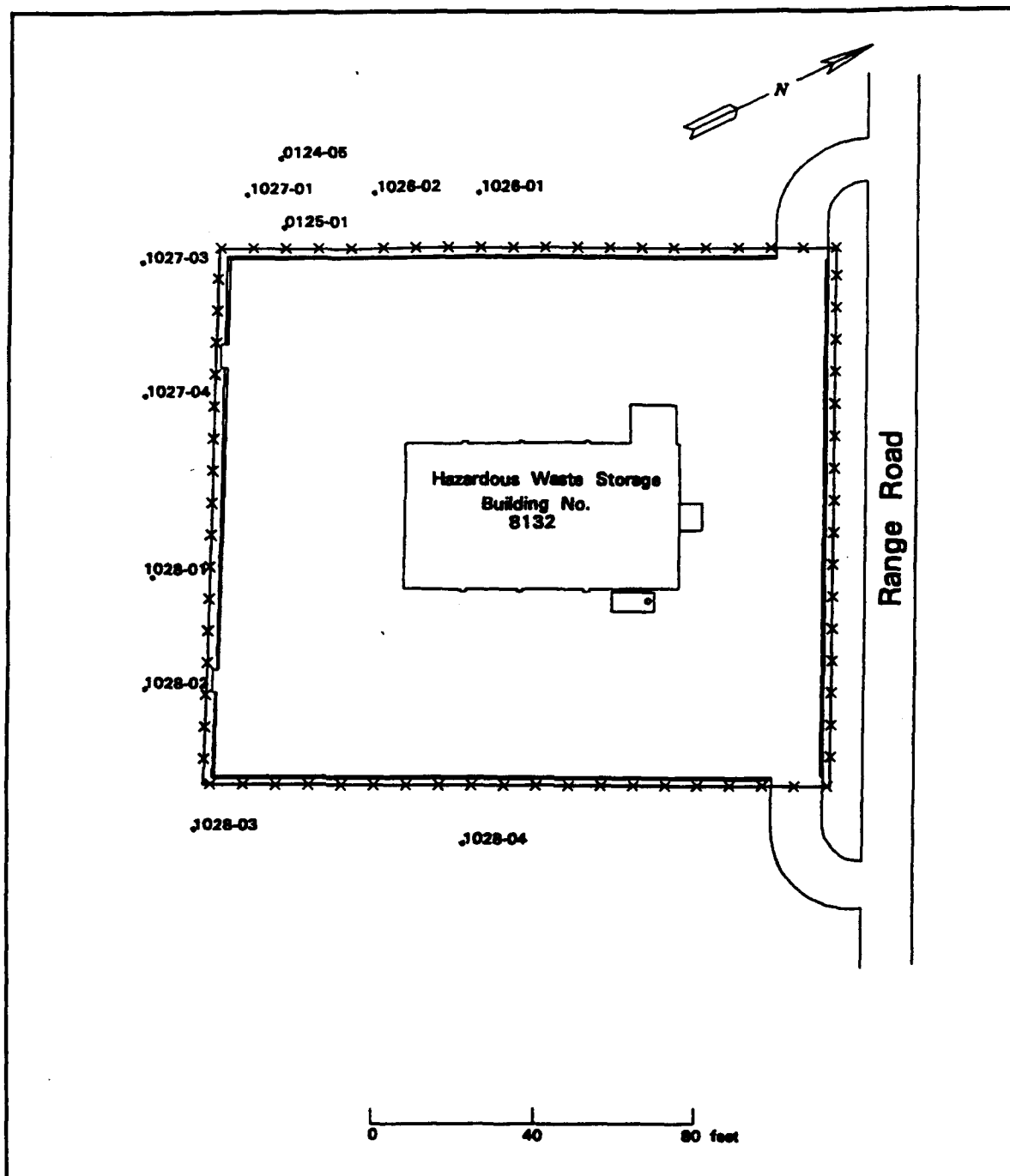

Figure 35. 8132 Hazardous Waste Storage Area site map

runoff. Beyond the cleared perimeter is an established (10 to 15 year old) Eastern Pine plantation that surrounds the facility on three sides.

The Hazardous Waste Storage Area was the first site chosen for the SCAPS operation at Fort Dix. Eleven penetrations were completed at this site, and all were located in the cleared perimeter between the fence line and the tree line (Appendix M). The depth of penetrations averaged

approximately 30 ft below ground surface, and the water table surface was encountered approximately 8 ft below the ground surface.

The fluorescence initially observed during penetrations 1026-01 and 1026-02 is due to ambient light entering the push rod at the ground surface. The soil did not collapse around the rod as the push was initiated. Low-levels of fluorescence (< 100 counts) were observed at a 20-ft depth in many of the penetrations on the site parameter. The lack of any pattern and the depth of the occurrence at 12 ft below the water table suggests the fluorometer response may not be due to POL contamination. Additional soil sampling may be warranted at this site to ascertain the source of fluorescence.

5 Summary, Conclusions, and Recommendations

Summary

Fort Dix site investigation/POL screening

Thirteen separate sites at Fort Dix were investigated using the SCAPS unit during a 12-week period. These sites have been identified as Areas Requiring Environmental Evaluation (AREE), and the AEC tasked the WES to perform SCAPS screening for possible subsurface POL contamination at each site, correlating with the SCAPS technology demonstration efforts. The truck-mounted laser-induced fluorometer (LIF) packaged with the conventional cone penetrometer was utilized for this mission. The unit's soil and groundwater sampling capabilities were also employed. At locations where significant fluorometer response (i.e., possible POL contamination patterns) were exhibited by the LIF, samples were retrieved for subsequent laboratory analysis.

No soil layers showing elevated fluorescence (indicating possible hydrocarbon contamination) were observed at the following sites:

- 5252 Boiler Plant
- 5426 Boiler Plant
- 5700 Area Motor Pool
- 5900 Area Motor Pool
- 8100 Area Motor Pool

LIF signatures indicating possible contamination were detected at the following sites:

- Bivouac Area 5 Washrack
- Fire Tank Training Area
- 4300 Area Motor Pool
- 4400 Area Motor Pool
- 5326 Post Boiler Plant Area (Laundry)
- 5800 Area Motor Pool
- 5881 Boiler Plant and Incinerator
- 8132 Hazardous Waste Storage Area

SCAPS demonstration

The WES SCAPS was successfully demonstrated during the site investigations at Fort Dix. The soil classification sensor (cone and friction sleeve) and the laser-induced fluorometer sensor performed well during each penetration event. The various subsystems (probe decontamination, grouting, verification sampling, and buried obstacle detection) were successfully utilized. Data acquisition, processing, and site mapping techniques ensured successful interpretation, integration, and presentation of the sensor system results.

Conclusions

Fort Dix site investigation/POL screening

Fluorescence intensities and patterns were examined for each of the eight sites that indicate possible POL contamination. Results of laboratory verification analyses on soil and groundwater samples were reviewed in combination with the fluorescence signatures to determine if POL contamination was present. Slightly higher fluorescence intensities were observed at the Bivouac Area 5 Washrack site and the 5326 Post Boiler Plant Area (Laundry). Verification samples taken at these sites indicated TRPH concentrations less than 25 ppm. It is concluded that, although the fluorescence patterns indicate hydrocarbon contamination, the TRPH concentrations are likely too low to warrant further actions solely based on this investigation.

Fluorescence intensities observed at the 4300 Area Motor Pool, the 5800 Area Motor Pool, the 5881 Boiler Plant and Incinerator, and the 8132 Hazardous Waste Storage Facility indicate the likelihood of threshold POL contamination in discrete soil layers under these sites. Verification samples were not taken at these sites.

Fluorescence patterns and verification sampling demonstrate higher-level POL contamination (> 25 ppm) is present under areas of the Fire Tank Training Area and the 4400 Area Motor Pool sites.

SCAPS demonstration

The demonstration of the WES SCAPS at Fort Dix provided additional insight into the capabilities of the system and challenges for improvement. All of the systems (from the laser induced fluorometer system to the grouting system) performed successfully, as has been previously demonstrated at other investigation sites. The major factors in the WES SCAPS Fort Dix demonstration included the following items:

- a. Duration of investigation.* The Fort Dix investigation was performed during a 12-week period (four times the length of previous SCAPS investigations). Winter weather hampered parts of the investigation.

- b. Number of penetrations.* The Fort Dix investigation entailed 321 penetrations (including sampling).
- c. Soil and groundwater sampling.* Verification samples were taken with a greater frequency than had been accomplished during previous investigations. Fifty-four soil and groundwater samples were retrieved with SCAPS samplers and analyzed in WES laboratories.
- d. Nature and extent of contaminant.* The nature and extent of hydrocarbon contamination encountered during previous investigations were more homogeneous and could be more fully characterized than that at Fort Dix, i.e. the use of SCAPS as a screening tool for contaminant detection played a bigger role at Fort Dix. The relatively low-level POL contamination encountered at the Fort Dix sites presented challenges to the design of the field operation including verification sampling frequency and locations. The lack of continuous vertical contaminant distribution caused difficulties in obtaining homogeneous soil and groundwater samples for calibration curve development.
- e. Interferences.* This demonstration of the SCAPS provided additional examples of interferences which can affect the use of the laser-induced fluorometer as a detector of hydrocarbon or POL contamination. Bitumens and aromatic hydrocarbons are extremely strong fluorophores, and fluorescent minerals are rare in alluvial soils, so any prominent fluorescent response in such soils will almost always be associated with hydrocarbon contamination, especially at investigation sites where the probability of hydrocarbon contamination is highest. However, fluorescence responses due to other causes have been found in this, and earlier, demonstrations of the SCAPS system. These include:
- (1) Fluorescent dyes (e.g. fluoresceine, rodamine) used as tracers or in antifreeze fluids.
 - (2) Optical brighteners used in laundry detergents and found in septic system effluents.
 - (3) Fluorescent minerals. At Fort Dix, pebbles of fluorescent quartzite were found in one soil layer. The fluorescence intensity was relatively weak.
 - (4) Sunlight penetrating to the optical window of the probe, in the top few inches of the soil when the soil does not collapse around the probe.
 - (5) Contamination of the apparatus due to use of a fluorescent lubricant on O-rings below the window (since discontinued).

Many other substances, man-made and of biological origin, are known to be fluorescent under ultraviolet illumination. In each case, all available evi-

dence should be considered in identifying what is the most probable source of fluorescence found in soils.

Recommendations

Fort Dix site investigation/POL screening

It is recommended that further verification sampling be conducted at four locations within the 4400 Area Motor Pool where relatively high fluorescence response patterns were observed and/or contaminated soil samples (TRPH > 25 ppm) were recovered. The sites are listed below:

- a. The area immediately north of the cemetery near penetration 1207-01 and 1207-02. Shallow POL contamination is possibly present at this site based on fluorometry.
- b. The location south of building 4468 and eastward toward penetration 1124-01. Higher fluorescence (up to 100 counts) at 1204-01 indicates POL may be present.
- c. The location on the east side of 4400 Area near the McGuire AFB fence near penetrations 1130-02 through 1203-03. Contaminated soil has been recovered at this point after the fluorometer indicated POL was present.
- d. The location between buildings 4431 and 4432 near penetrations 0116-01 and 0116-02. Contaminated soil was observed in samples taken near the oil-water separator.

Additional sampling is also warranted along the northern boundary of the Fire Tank Training Area. Elevated fluorescence levels in penetration 1114-01 and presence of hydrocarbon in soil and water samples indicates possible POL contamination.

Additional sampling and laboratory analysis are recommended near penetrations 0127-04 and 0127-06 (approximately five feet below surface) at the 5800 Area Motor Pool.

Additional sampling and laboratory analysis are recommended near penetrations 1104-03 and 1104-04 (approximately 20 ft below surface) at the 5881 Boiler Plant and Incinerator.

Additional sampling and laboratory analysis are recommended near penetrations 0112-01, 0113-05, 0113-07 and 0113-02 through 0113-04 (approximately 15 ft below surface) at the 4300 Area Motor Pool site.

Additional sampling and laboratory analysis are recommended along the perimeter of the 8132 Hazardous Waste Storage Area based on the persistent low-level fluorescence observed at this site.

SCAPS Demonstration

Recommendations for expanded capabilities at future sites to be investigated (screened) include:

- a. Cold weather operations reduce the efficiency of production and greatly increase safety risks. Consider the impact of cold weather on cost and safety when scheduling SCAPS operations.
- b. Data processing efficiency will be increased if each penetration event is surveyed in real time. A Global Positioning System (GPS) installed on the truck and integrated into the database management system is recommended.
- c. Improved grouting capabilities are required; specifically, improved high pumpability grouts which adequately seal penetration holes in all types of soils are needed. The grout used at Fort Dix will not be suited for sealing clay soils with hydraulic conductivities less than 1×10^{-5} cm/sec. It is recommended that research into other types of grouts be completed prior to a site investigation at a location with predominantly clay soils.
- d. Improved samplers for soil and groundwater are required. It is recommended that enhanced samplers for retrieving saturated soil samples and larger-quantity (> 1 liter) groundwater samples be developed for use with the SCAPS.
- e. It is recommended that standardized verification sampling protocols be established. Verification samples are required to assure sensor calibration and correlation to contaminant concentrations. However, verification sampling substantially increases project costs and must be weighed accordingly. At sites such as Fort Dix where the fluorescence intensities were relatively low-level, verification samples helped confirm the sensitivity of the fluorometer. A more robust sampling program would have limited the number of sites visited within the allotted site investigation timeframe at Fort Dix.
- f. Additional research into the effects of fluorometer response as a function of soil matrix is recommended. Such effects become more critical when soil matrix effects potentially mask low-level contamination fluorometer response.
- g. Additional research into the effects of interferences on the fluorometer response is recommended. The interactions of the soil matrix, mineral compounds that fluoresce, degrading hydrocarbon compounds, and

biological processes must be better understood to ensure that site characterization and screening procedures are accomplished in as cost effective a manner as possible.

- h.* Analysis of the effects of the independent variables on fluorometer response (referenced in items *f* and *g* above) should not be limited to the maximum amplitude and wavelength variables. The entire spectrum of fluorometer response should be analyzed.

Bibliography

- Apitz, S. E., Borbridge, L. M., Theriault, G. A., and Lieberman, S. H. (1992). "Remote In-situ Determination of Fuel Products in Soils." *Field Results and Laboratory Investigations. Analysis*, Vol. 20, 461-474.
- ASTM. (1991). *Annual Book of ASTM standards*. 04.08:439-444. Philadelphia: ASTM.
- Barrows, L. and Rocchio, J. E. (1990). "Magnetic Surveying for Buried Metallic Objects," *Groundwater Monitoring Review*, Vol. 10(3), 204-11.
- Bevan, P. W. (1983). "Electromagnetics for Mapping Buried Earth Features," *Journal of Field Archaeology*, Vol. 10.
- Briggs, I. C. (1974). "Machine Contouring for Minimum Curvature," *Geophysics*, 39:39-48.
- Campanella, R., Robertson, P. (1982). "State of the art in in-situ testing of soils: Developments since 1978." Dept. of Civil Eng. Vancouver: Univ. of British Columbia.
- CDM (Camp, Dresser and McKee, Inc. 1986). "Remedial Investigation/ Feasibility Study Report for the Fort Dix Sanitary Landfill Site." Prepared for U.S. Army Corps of Engineers, Philadelphia District, Philadelphia, PA.
- Comes, G. P., Malone, P. G. and Cooper, S. S. (1991). "Hazardous Waste Site Investigation/Characterization using a Cone Penetrometer System," Presented at the Society of American Military Engineers First Technology Transfer Conference on Environmental Cleanup, Nov. 13-15.
- Cooper, S. S., Malone, P. G., Lurk, P. W. and Lieberman, S. H. (1989). "Development of Innovative Penetrometer Technology for the Detection and Delineation of Contaminated Soils," Technical Report CETHA-TE-TR-90055, Proceedings of the 14th Annual Army Environmental R&D Symposium. U.S. Army Toxic and Hazardous Materials Agency, Aberdeen Proving Ground, MD. 577-88.

- Cooper, S. S., Malone, P. G. and Lieberman, S. H. (1990). "Tracking Simulated Contaminant Plumes Using a Cone Penetrometer," Presented at the 1990 Annual Meeting of the Association of Engineering Geologists.
- Cooper, S. S., Malone, P. G., Olsen, R. S., and Douglas, D. H. (1988). "Development of a Computerized Penetrometer System for Hazardous Waste Site Soils Investigation," Report AMXTH-TR-TE-882452, U.S. Army Toxic and Hazardous Materials Agency, Aberdeen Proving Ground, MD.
- Cooper, S. S. et al. (1988). "Use of an Instrumented Cone Penetrometer in Monitoring Land Disposal Sites," Proceedings of the 5th National Conference on Hazardous Wastes and Hazardous Materials, Hazardous Materials Control Research Institute, Silver Springs, MD, 424-427.
- Dake, H. C. (1953). "The Uranium and Fluorescent Minerals," Mineralogist Publication Co., Portland, OR.
- Dames and Moore. (1991). "Remedial Investigation, Fort Dix, New Jersey." Report prepared for USATHAMA under Contract No. DAAA-15-88-D-008.
- Douglas, B. and R. Olsen. (1981). "Evaluation of the cone penetrometer test for SPT liquefaction Assessment." In G. Norris and R. Holtz (eds.), *Cone Penetration Testing and Experience*. 209-27. New York: ASCE.
- Douglas, G. S., et al. (1992). "The Use of Hydrocarbon Analyses for Environmental Assessment and Remediation," *Journal of Soil Contamination*. Vol 1, 197-212.
- EA (EA Engineering, Science, and Technology, Inc.). (1989). "Final Report, U.S. Army Training Center and Fort Dix Preliminary Assessment/ Site Investigation." Prepared for USATHAMA.
- ICF Kaiser, Inc. (1992). "Fort Dix Environmental Investigation/Alternatives Analysis Work Plan." Prepared for USATHAMA.
- IKW (Iffland, Kavanagh, Waterbury, P.C.). (1985). "Report of Groundwater Contamination at Three Sites, Fort Dix, New Jersey." Prepared for the U.S. Army Corps of Engineers, New York District, New York, NY. 16 October 1985.
- Inman, S. M., Thibado, P. M., Theriault, G. and Lieberman, S. H. (1990). "Laser-Induced, Pulsed Time-Resolved Fluorometry over Fiber Optic Cables: Characterization of Polycyclic Aromatic Hydrocarbons in Seawater." *Anal. Chim. Acta*, 239, pp. 45-51.

- Lieberman, S. H., Inman, S. M. and Stromvall, E. J. (1987). "Fiber Optic-Fluorescence Sensors for Remote Detection of Chemical Species in Seawater." *Proceedings of the Symposium on Chemical Sensors*, Vol. 87, Electrochemical Society, Pennington, N.J., pp. 464-473.
- Lieberman, S. H., Inman, S. M. and Theriault, G. A. (1990). "In-Situ, Remote Measurement of Laser-Induced Fluorescence Emission Spectra of Aromatic Hydrocarbons in Seawater using Fiber Optic Cables." *EOS*, 71, 133.
- Lieberman, S. H., Inman, S. M. and Theriault, G. A. (1989). "Use of Time-Resolved Fluorometry for Improving Specificity of Fiber Optic Based Chemical Sensors," *Chemical, Biochemical and Environmental Fiber Sensors, Proceedings SPIE*, Bellingham, WA, 1172, 94-8.
- Long, J. R., Gregoriou, V. G., and Gemperline, P. J. (1990). "Spectroscopic Calibration and Quantitation using Artificial Neural Networks." *Anal. Chem.*, 62, 1791-97.
- Lurk, P. W., Cooper, S. S., Malone, P. G., and Lieberman, S. H. (1990). "Development of Innovative Penetrometer Systems for the Detection and Delineation of Contaminated Groundwater and Soil." *Superfund 90: Proceedings of the HMCRI 11th Annual National Conference*, Hazardous Materials Control Research Institute, Silver Spring, MD. 297-306.
- McNeil, J. D. (1980). "Electromagnetic Terrain Conductivity Measurements at Low Induction Numbers," Technical Note TN-6, Geonics Limited, Mississauga, Ontario, Canada.
- Murphy, E. M., and Hostetler, D. D. (1989). "Evaluation of Chemical Sensors for In Situ Ground-water monitoring at the Hanford Site," Report PNL-6854, Pacific Northwest Laboratory, Richland, WA.
- Olsen, R. (1988). "Using the CPT for dynamic site response characterization. Specialty Conference II on Earthquake Engineering and Soil Dynamics. Park City, UT: ASCE.
- Olsen, R. S. and Farr, J. V. (1986). "Site Characterization Using the Cone Penetrometer Test," *Proceedings of the ASCE Conference on Use of In-Situ Testing in Geotechnical Engineering*. Amer. Soc. of Civil Eng., New York, NY.
- Owens, J. P. and Minard, J. P. (1960). "The Geology of the North-Central part of the New Jersey Coastal Plains." *Johns Hopkins University Studies in Geology*, No. 18.
- Schlager, Kenneth. (1990). "Fiber Fluorometry (Spectrometry) for On-line Chemical Analysis of Nutrient Solutions," Final Report to National Aeronautics and Space Administration, NASA Contract No. NAS10-11656, 65.

- Seitz, W. R. (1984). "Chemical Sensors Based on Fiber Optics." *Anal. Chem.*, 56, 16A-34A.
- Sharp, M. K. et al. (1992). "Field Evaluation of the Site Characterization and Analysis Penetrometer System at the Philadelphia Naval Shipyard, Philadelphia, Pennsylvania." U.S. Army Engineer Waterways Experiment Station, Vicksburg, MS. December 1992.
- Sharp, M. K. et al. (1992). "Use of the Site Characterization and Analysis Penetrometer System at the Grandville Superfund Site, Grandville, Michigan." U.S. Army Engineer Waterways Experiment Station, Vicksburg, MS. December 1992.
- U.S. Patent Office. (1992). "Device for Measuring Reflectance and Fluorescence of In-situ Soil." Patent No. 5,128,882 issued July 7, 1992.
- USAEHA (U.S. Army Environmental Hygiene Agency). (1984). "Groundwater Contamination by Organic Compounds, Fort Dix, New Jersey, 3 July-10 August 1984." Water Quality Engineering Study No. 32-24-0456-85.
- USAEHA. (1975). "Evaluation of Pesticide Distribution in Selected Components of the Environment at Fort Dix." Pesticide Monitoring Study No. 44-0172-78.
- USAEHA. (1985). "Evaluation of Pesticide Residues at Selected Environmental Sites of Fort Dix, New Jersey, 9-13 September 1985." Pesticide Monitoring Study No. 17-44-0263-87.
- USAEHA. (1986). "Monitoring of the Zone III, Fort Dix, New Jersey, 18-25 November 1986." Environmental Noise Assessment No. 52-34-0464-87.
- USATHAMA (U.S. Army Toxic and Hazardous Materials Agency). (1977). "Installation Assessment of Fort Dix (BOMARC Site)." Report 108. Aberdeen Proving Ground, MD. March 1977.
- USATHAMA. (1988). USATHAMA Property Report- Fort Dix, New Jersey, Aberdeen Proving Ground, MD. 12 April 1988.
- USATHAMA. (1989). "Preliminary Assessment/Site Investigation." Prepared by EA Engineering, Science, and Technology, Inc. for USATHAMA. January 1989.
- USATHAMA. (1992). "Enhanced Preliminary Assessment." Prepared by Roy F. Weston, Inc. for USATHAMA. March 1992.
- U.S. EPA. (1984). "Test Methods for Evaluating Solid Waste Physical/Chemical Methods," SW-846 Third Edition. U.S. Environmental Protection Agency, Washington, DC.

Appendix A

Bivouac Area 5 Washrack

Verification Sample Information Bivouac Washrack				
Sample No.	29517	29527		
Type	Soil	Soil		
Lab Method	8270	8270		
TRPH, ppm	---	---		
Other, ppm	PAH-Table 3	PAH-Table 3		
Easting, ft	2023159	2023187		
Northing, ft	427887	427903		
Elevation Range ft MSL	105-106	89-90		
Sample Fluoresced?	No	Yes		
Maximum Intensity, counts	0	107		
Peak Wavelength, nm	N/A	478		
Nearest Probe	0121-06	0124-02		
Easting, ft	2023158	2023186.8		
Northing, ft	427886.1	427902.6		
Offset from Sample, ft	2	2		
Soil Classification at Sample Elevation	Sand	Sand/Silt		
Intensity Range counts	0	25-175		
Peak Wavelength, nm	N/A	510		
<i>(Continued)</i>				
<p>TRPH = Total Recoverable Petroleum Hydrocarbons. PAH = Polynuclear Aromatic Hydrocarbons. TOC = Total Organic Carbon. OG = Oil and Grease. ppm = parts per million. Lab Method = USEPA SW-846, 1984.</p>				

Verification Sample Information Bivouac Washrack (Concluded)				
Sample No.	29292	29280	28542	29290
Type	Water	Soil	Water	Soil
Lab Method	418.1/415.1	418.1/415.1	418.1/415.1	418.1/415.1
TRPH, ppm	<0.5	<25	<0.5	<25
Other, ppm	23 (TOC)	1613 (TOC)	275.5 (TOC)	1802 (TOC)
Easting, ft	2023141	2023159	2023164	2023141
Northing, ft	427799	427888	427854	427798
Elevation Range ft MSL	96-97	105-106	89-90	88-89
Sample Fluoresced?	No	No	Yes	Yes
Maximum Intensity, counts	0	0	107	48
Peak Wavelength, nm	577	N/A	478	501
Nearest Probe	0123-02	0121-06	0123-03	0123-02
Easting, ft	2023140.5	2023158	2023164	2023140.5
Northing, ft	427798	427886.1	427853	427798
Offset from Sample, ft	2	2	2	2
Soil Classification at Sample Elevation	Sand	Sand	Silt	Sand
Intensity Range counts	0-50	0	25-175	0-50
Peak Wavelength, nm	520	N/A	440	520
<p>TRPH = Total Recoverable Petroleum Hydrocarbons. PAH = Polynuclear Aromatic Hydrocarbons. TOC = Total Organic Carbon. OG = Oil and Grease. ppm = parts per million. Lab Method = USEPA SW-846, 1984.</p>				

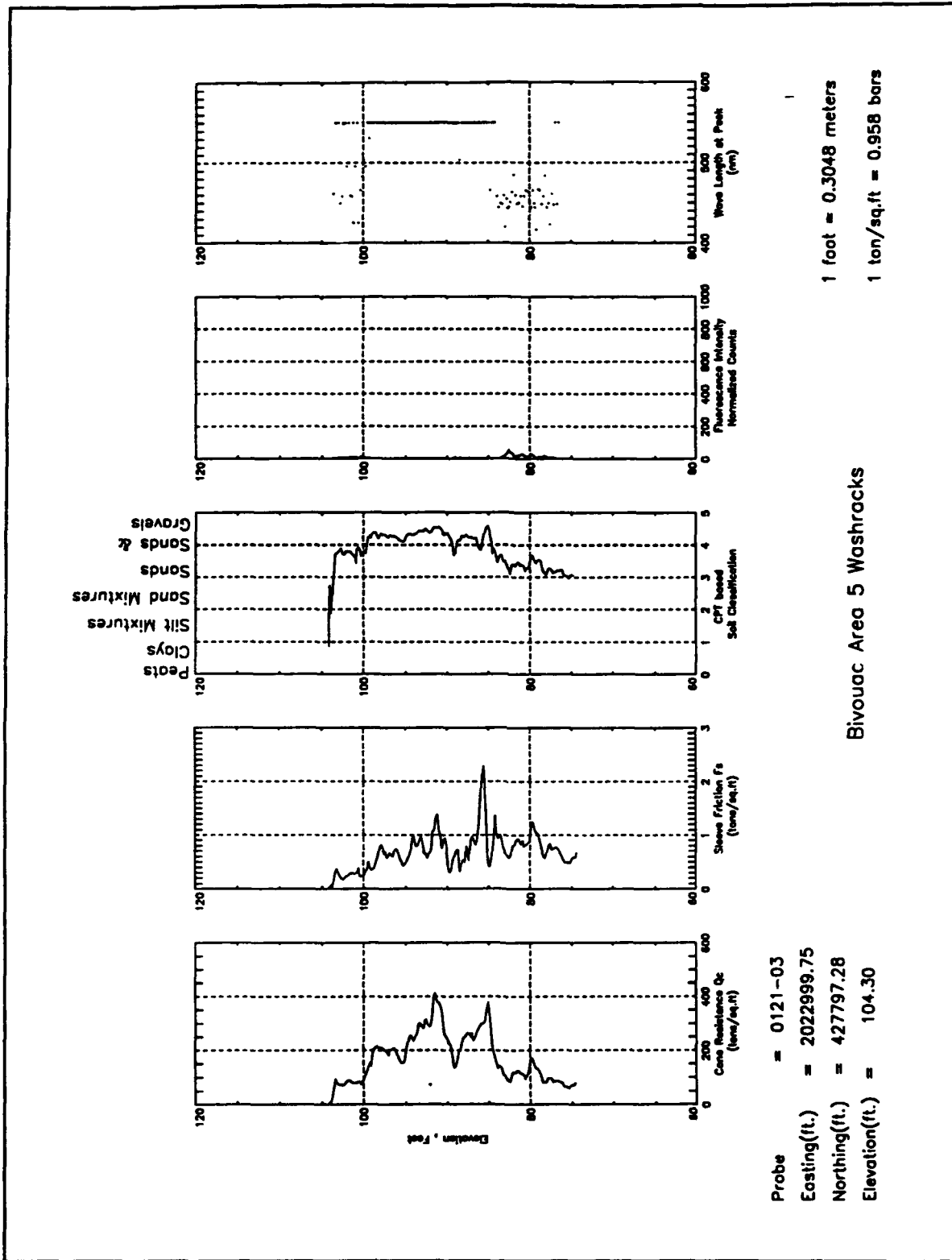

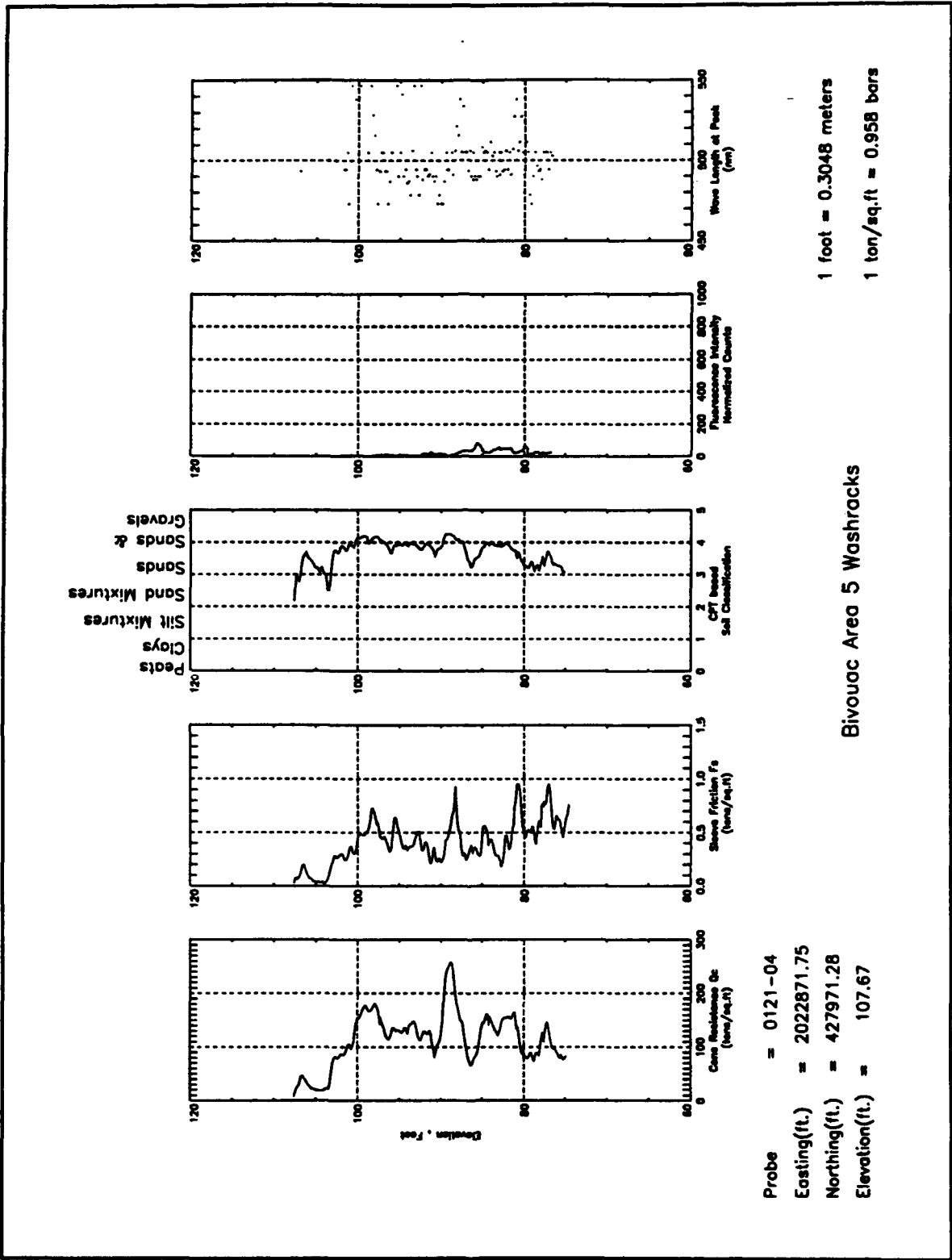

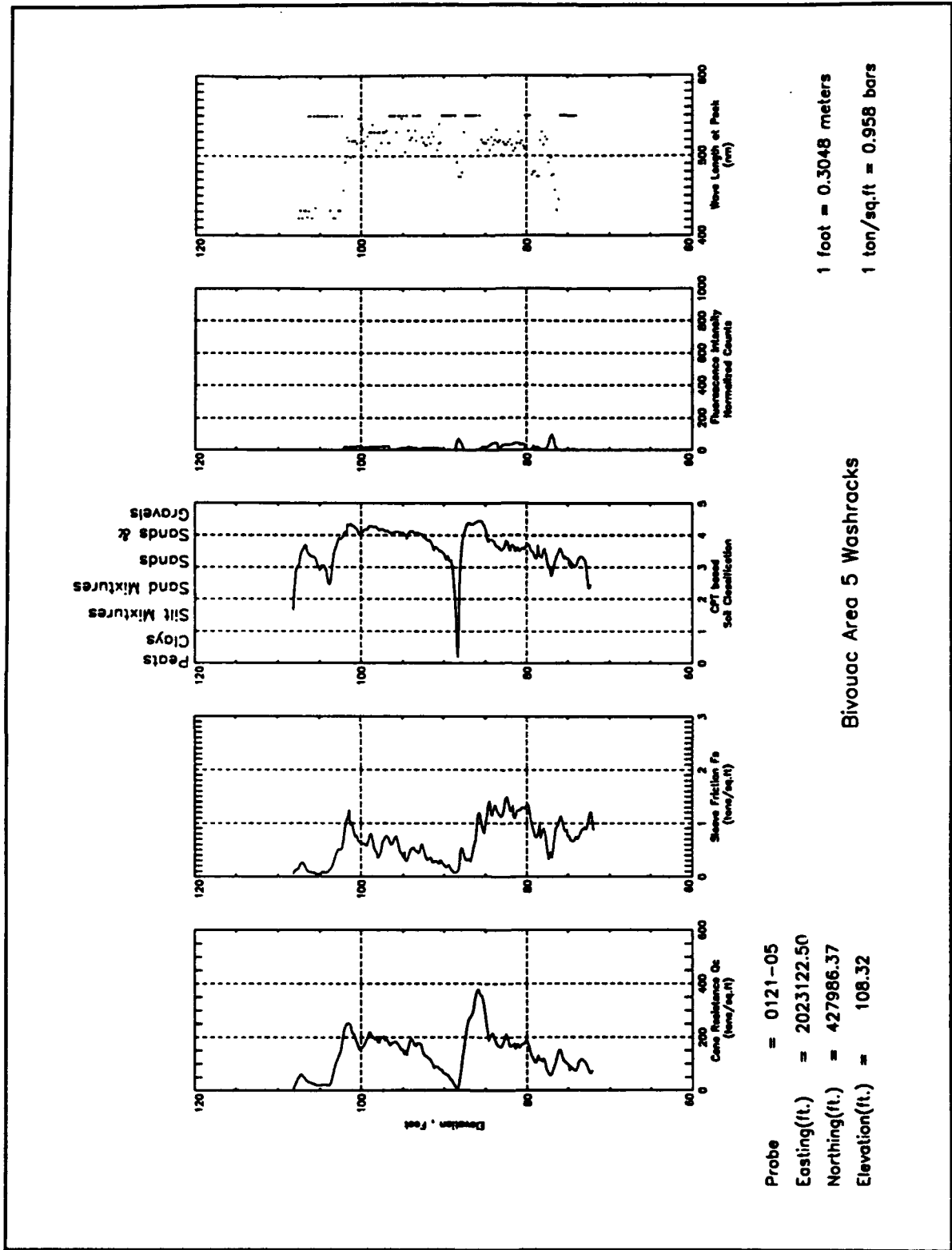

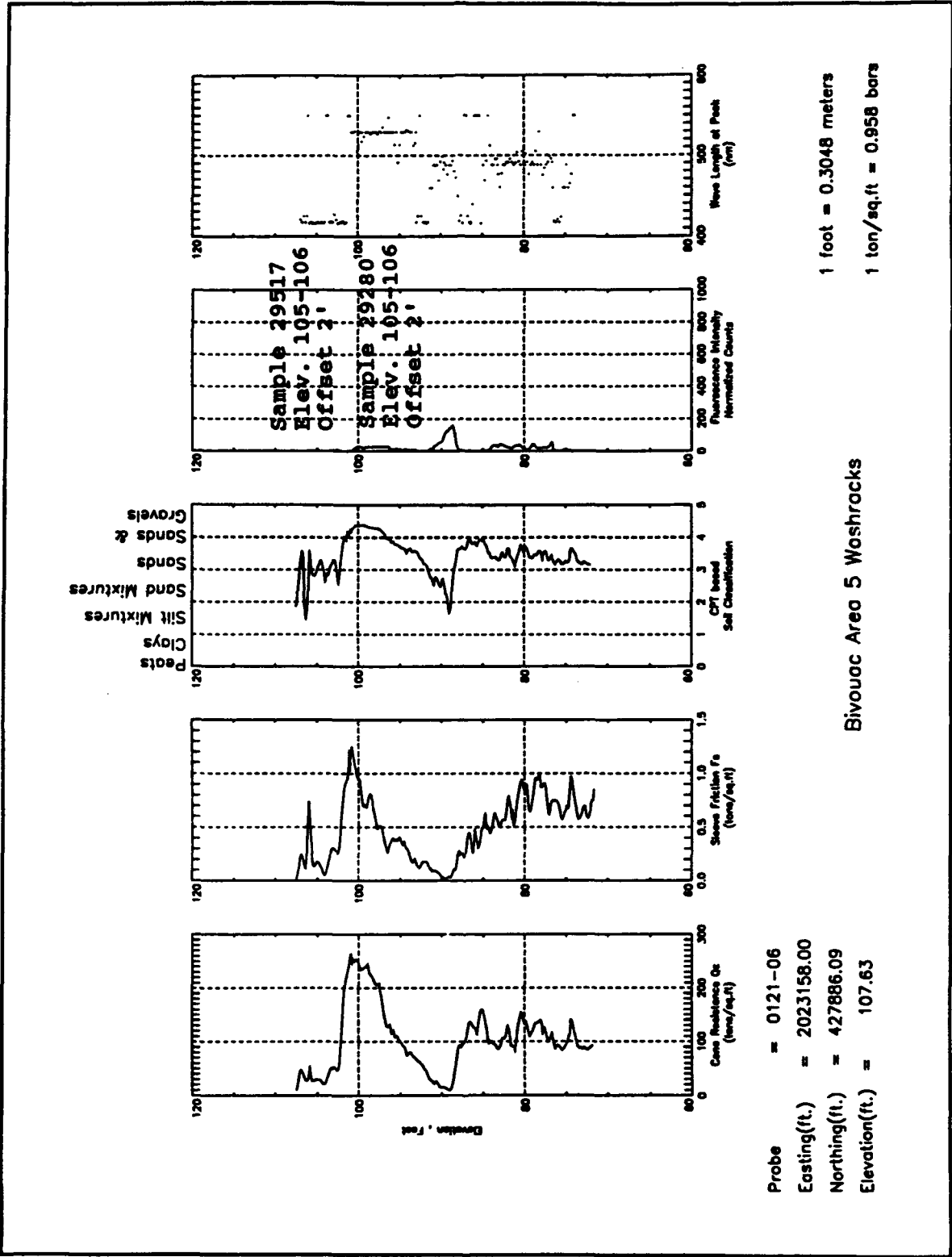

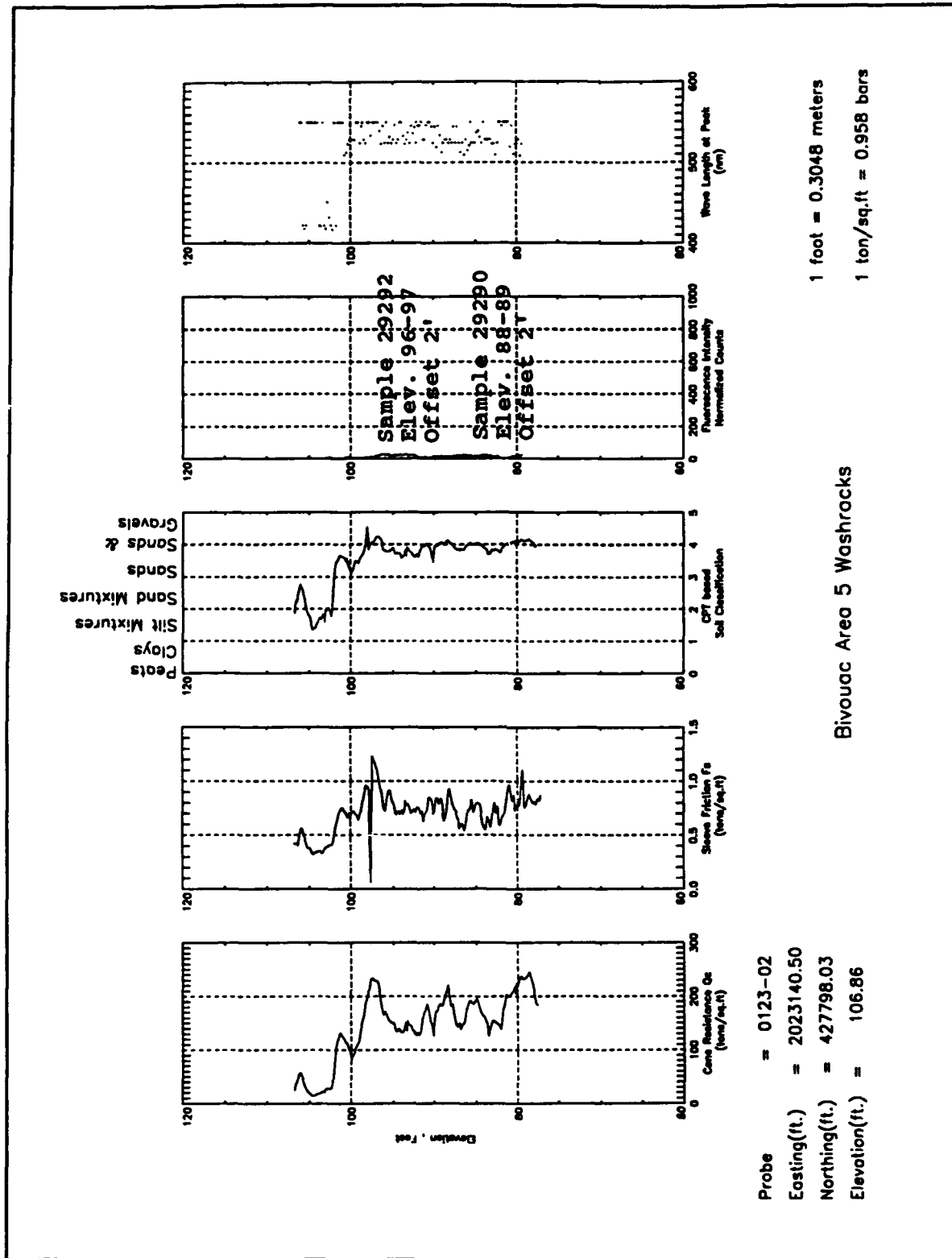

Probe = 0123-02
 Easting(ft.) = 2023140.50
 Northing(ft.) = 427798.03
 Elevation(ft.) = 106.86

Bivouac Area 5 Washracks

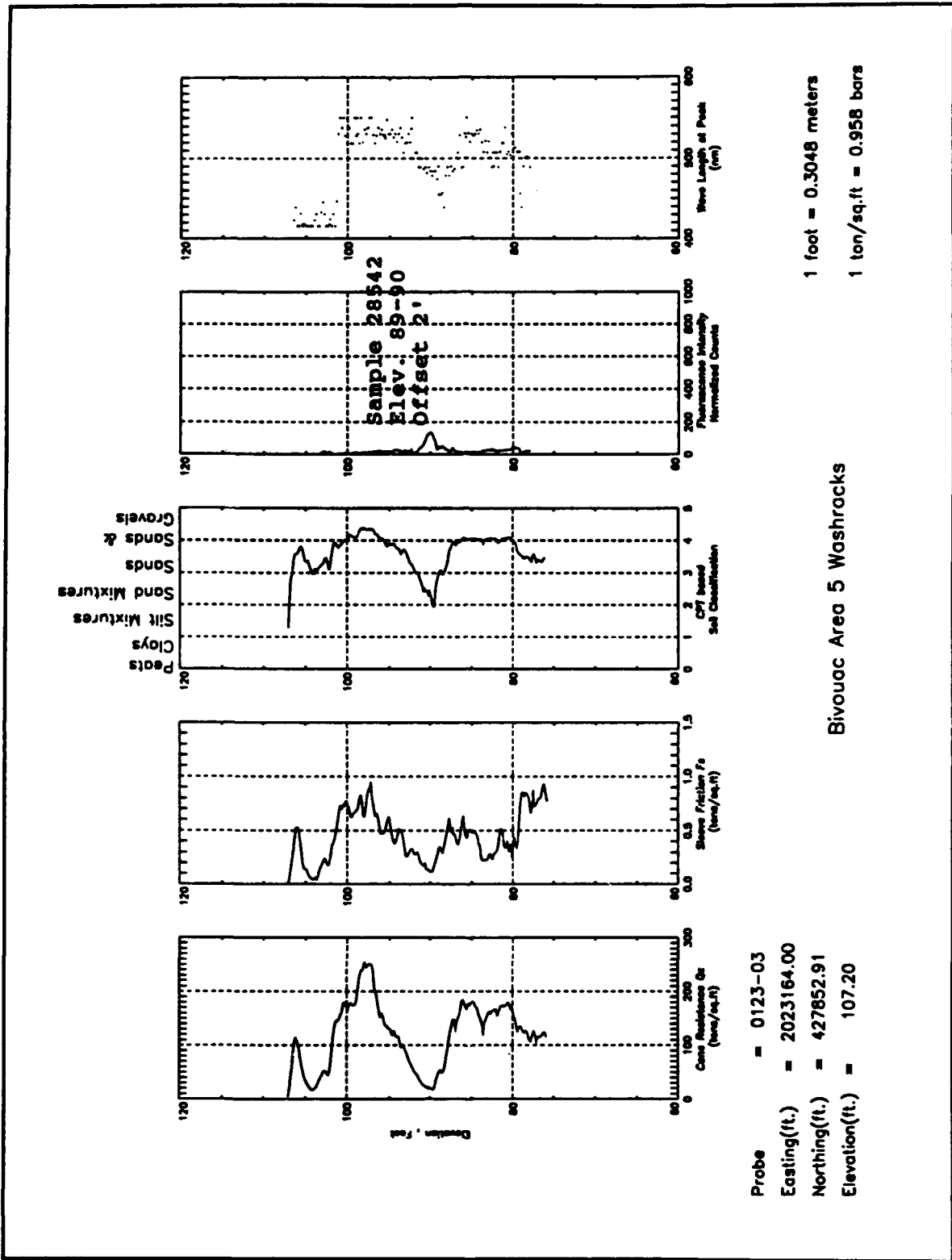

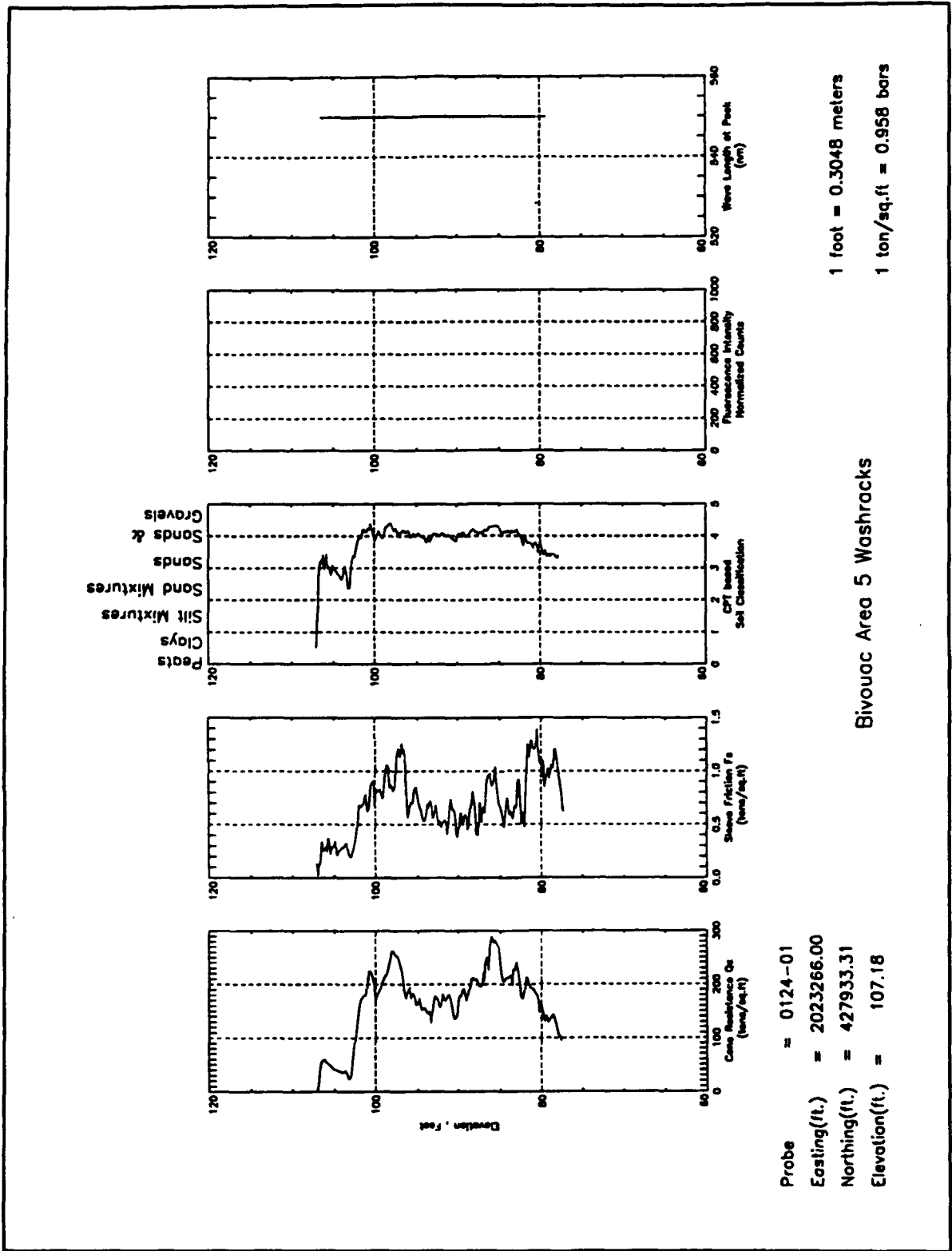

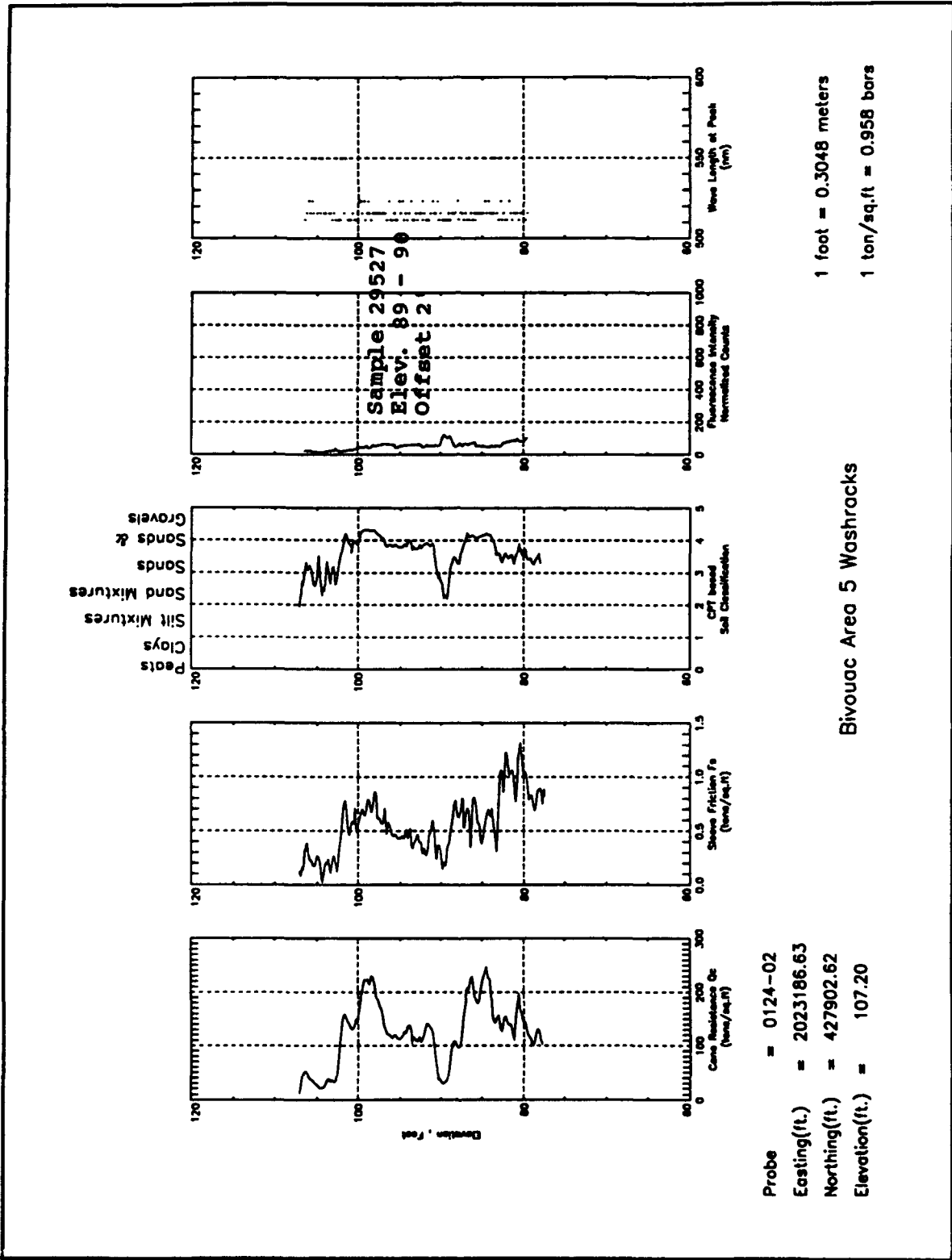

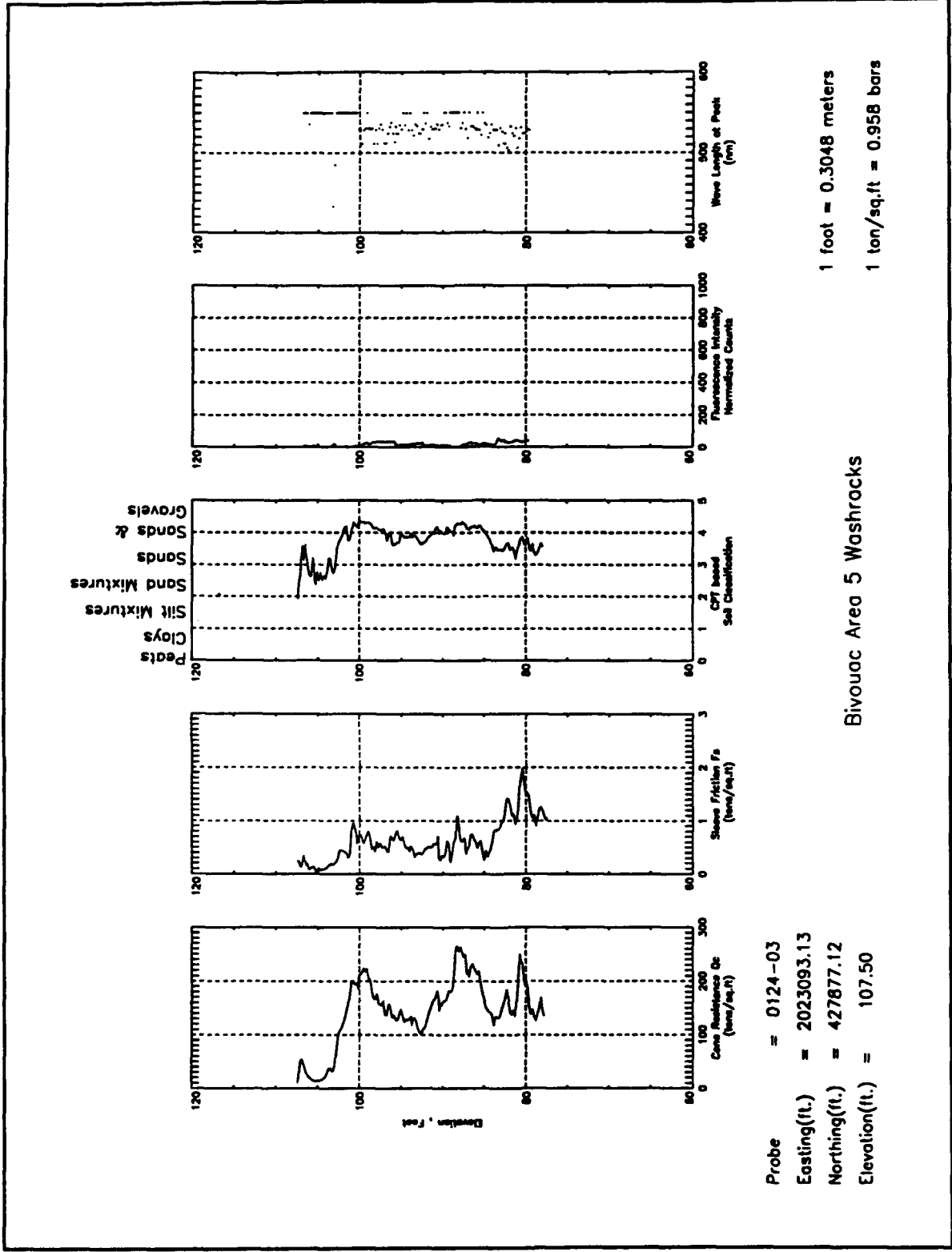

Probe = 0124-03
 Easting(ft.) = 2023093.13
 Northing(ft.) = 427877.12
 Elevation(ft.) = 107.50

1 foot = 0.3048 meters
 1 ton/sq.ft = 0.958 bars

Bivouac Area 5 Washrocks

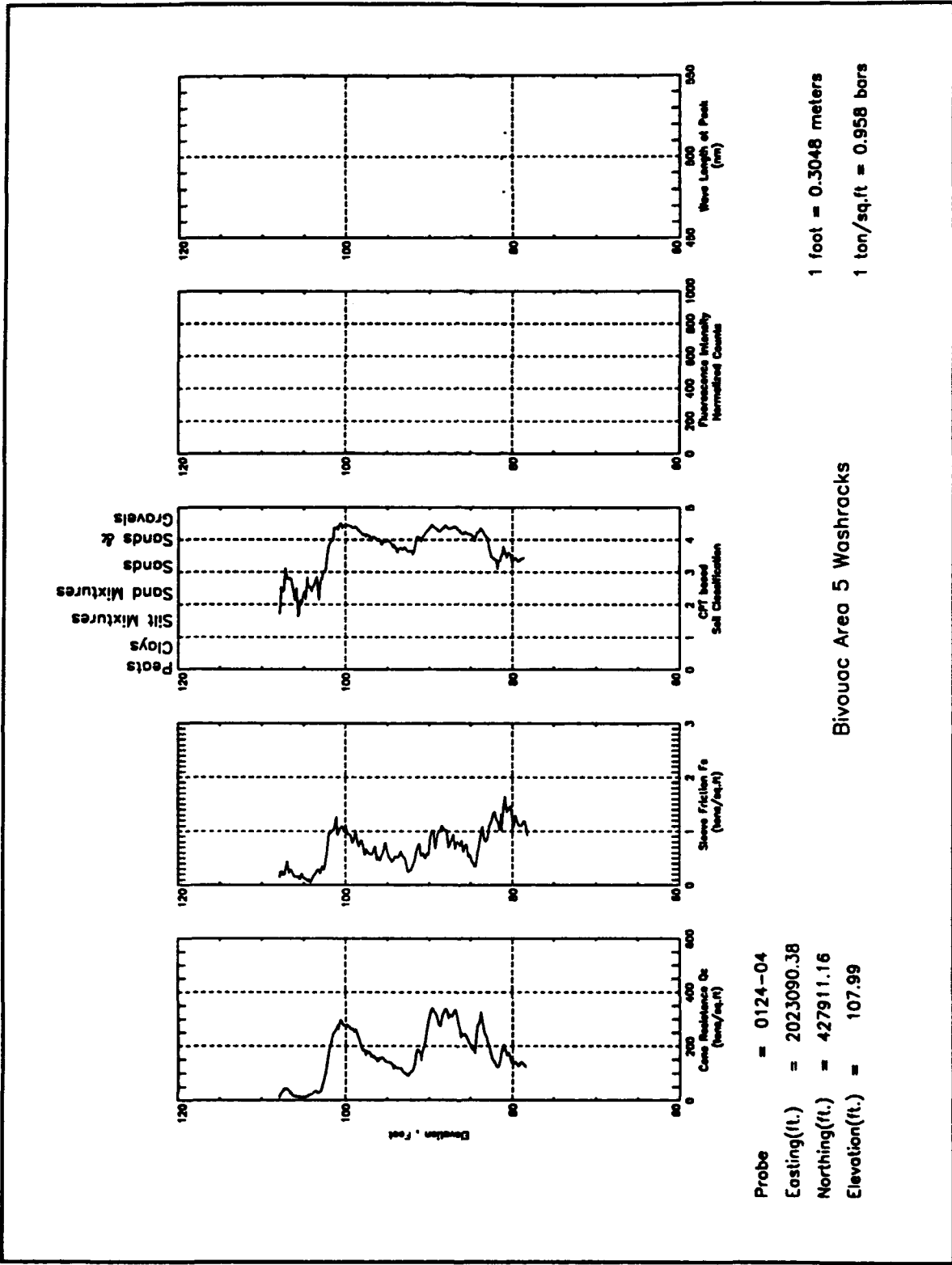

Appendix B Fire Tank Training Area

Verification Sample Information Fire Tank Training Area				
Sample No.	26942	26810	26811	29520
Type	Soil	Soil	Soil	Soil
Lab Method	418.1/413.2	418.1/413.2	418.1/413.2	418.1/413.2
TRPH, ppm	<25	<25	<25	
Other, ppm	3 (OG)	<25 (OG)	30 (OG)	PAH-Table 5
Easting, ft	2013801	2013843	2013693	2013773
Northing, ft	432539	432533	432572	432539
Elevation Range ft MSL	129-130	114-115	116-117	130-131
Sample Fluoresced?	Yes	Yes	Yes	No
Maximum Intensity, counts	11	42	27	0
Peak Wavelength, nm	500	439	500	566
Nearest Probe	1110-03	1110-05	1114-02	1110-02
Easting, ft	2013799.6	2013842.2	2013692.5	2013772.1
Northing, ft	432538.1	432532.6	432571.3	432547.1
Offset from Sample, ft	2	2	2	2
Soil Classification at Sample Elevation	Sand	Silt	Sand	Sand
Intensity Range counts	0	0-200	0	0-10
Peak Wavelength, nm	N/A	490	N/A	550
<p>TRPH = Total Recoverable Petroleum Hydrocarbons. PAH = Polynuclear Aromatic Hydrocarbons. TOC = Total Organic Carbon. OG = Oil and Grease. ppm = parts per million. Lab Method = USEPA SW-846, 1984.</p>				
<i>(Sheet 1 of 3)</i>				

Verification Sample Information Fire Tank Training Area (Continued)				
Sample No.	29291	29293	29283	29287
Type	Water	Water	Soil	Soil
Lab Method	418.1/415.1	418.1/415.1	418.1/415.1	418.1/415.1
TRPH, ppm	0.7	0.1	<25	<25
Other, ppm	42 (TOC)	34 (TOC)	2842 (TOC)	11237 (TOC)
Easting, ft	2013801	2013801	2013773	2013801
Northing, ft	432539	432539	432548	432539
Elevation Range ft MSL	111-112	120-121	130-131	110-111
Sample Fluoresced?	No	No	No	Yes
Maximum Intensity, counts	0	0	0	2
Peak Wavelength, nm	403	585	566	575
Nearest Probe	1110-03	1110-03	1110-02	1110-03
Easting, ft	2013799.6	2013799.6	2013772.1	2013799.6
Northing, ft	432538.1	432538.1	432547.1	432538
Offset from Sample, ft	2	2	2	2
Soil Classification at Sample Elevation	Clay	Sand	Sand	Clay
Intensity Range counts	50-200	0	0-10	50-200
Peak Wavelength, nm	490	N/A	550	490
<p>TRPH = Total Recoverable Petroleum Hydrocarbons. PAH = Polynuclear Aromatic Hydrocarbons. TOC = Total Organic Carbon. OG = Oil and Grease. ppm = parts per million. Lab Method = USEPA SW-846, 1984.</p>				
<i>(Sheet 2 of 3)</i>				

Verification Sample Information Fire Tank Training Area (Concluded)				
Sample No.	29524			
Type	Soil			
Lab Method	8270			
TRPH, ppm				
Other, ppm	PAH-Table 5			
Easting, ft	2013801			
Northing, ft	432539			
Elevation Range ft MSL	110-111			
Sample Fluoresced?	Yes			
Maximum Intensity, counts	2			
Peak Wavelength, nm	575			
Nearest Probe	1110-03			
Easting, ft	2013800			
Northing, ft	432538			
Offset from Sample, ft	2			
Soil Classification at Sample Elevation	Clay			
Intensity Range counts	50-200			
Peak Wavelength, nm	490			
TRPH = Total Recoverable Petroleum Hydrocarbons. PAH = Polynuclear Aromatic Hydrocarbons. TOC = Total Organic Carbon. OG = Oil and Grease. ppm = parts per million. Lab Method = USEPA SW-846, 1984.				
<i>(Sheet 3 of 3)</i>				

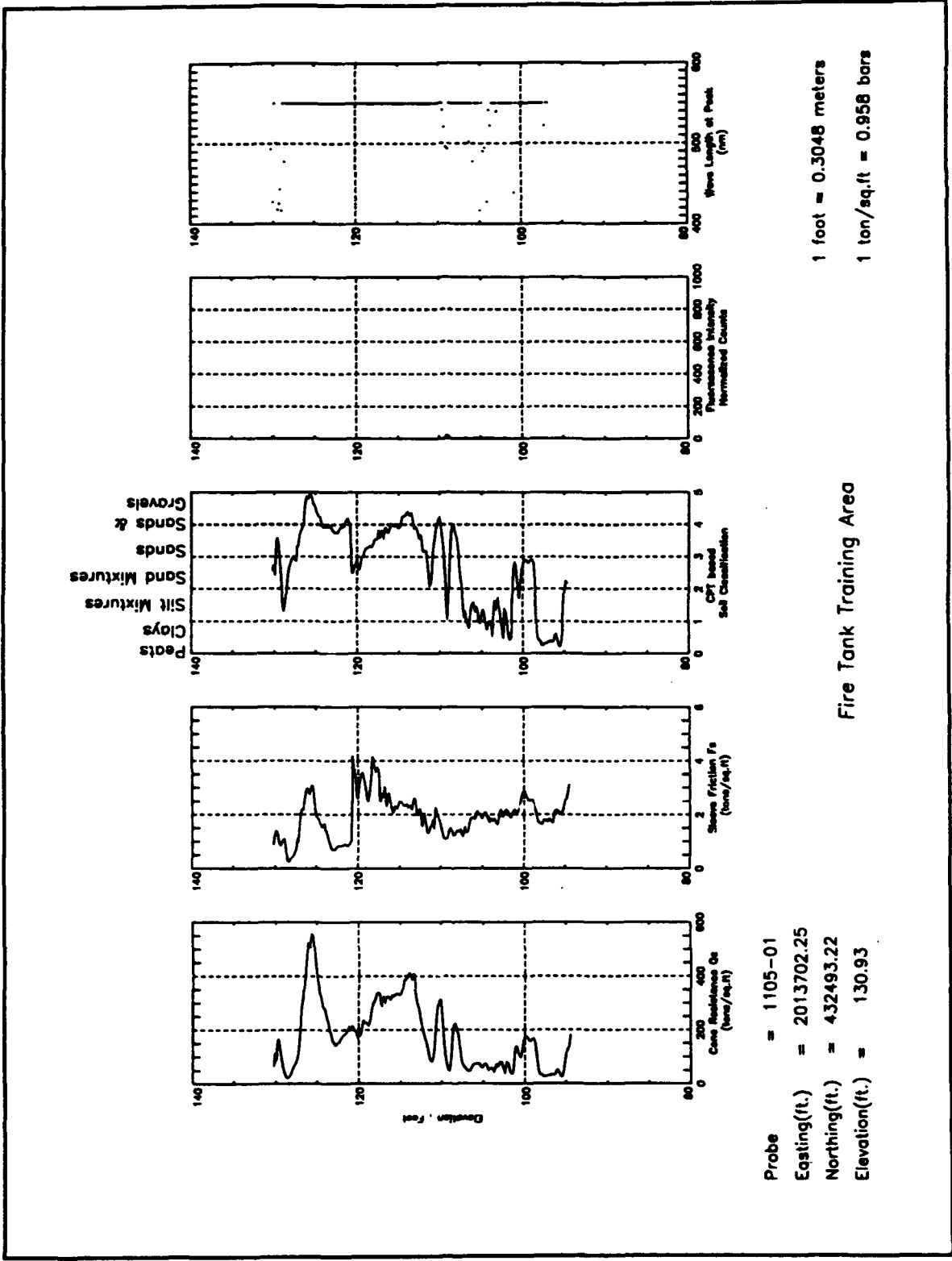

Probe = 1105-01
 Easting(ft.) = 2013702.25
 Northing(ft.) = 432493.22
 Elevation(ft.) = 130.93

1 foot = 0.3048 meters
 1 ton/sq.ft = 0.958 bars

Fire Tank Training Area

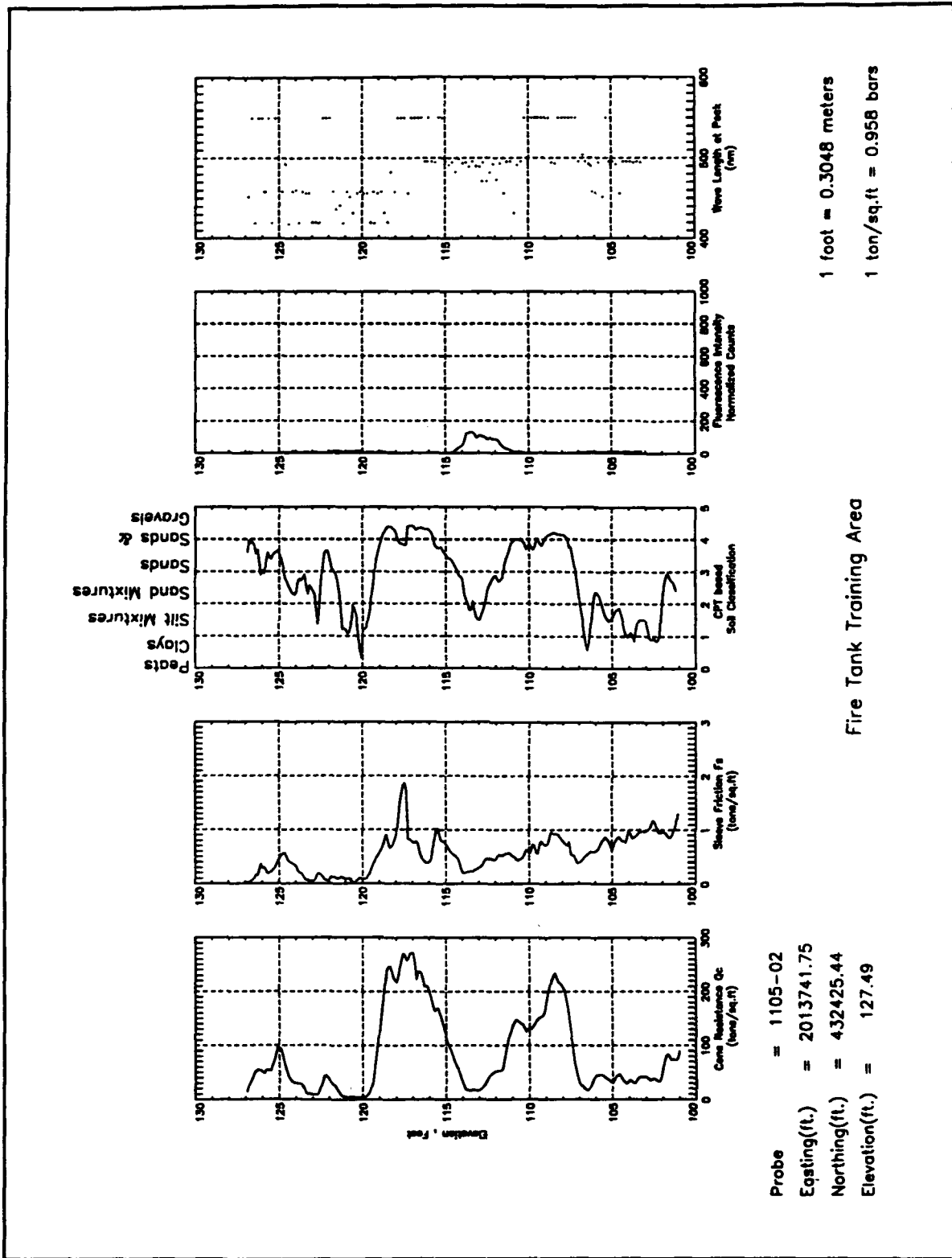

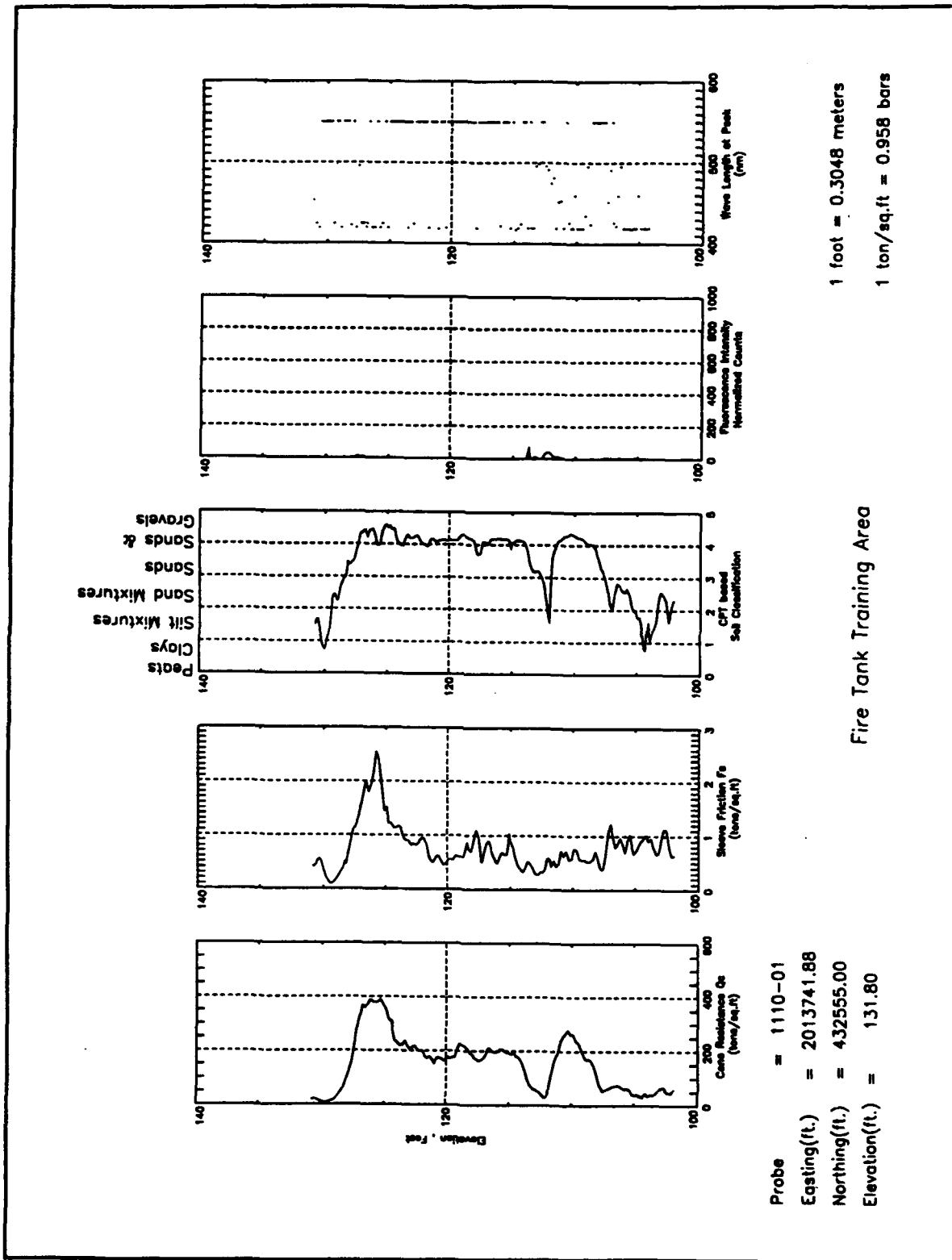

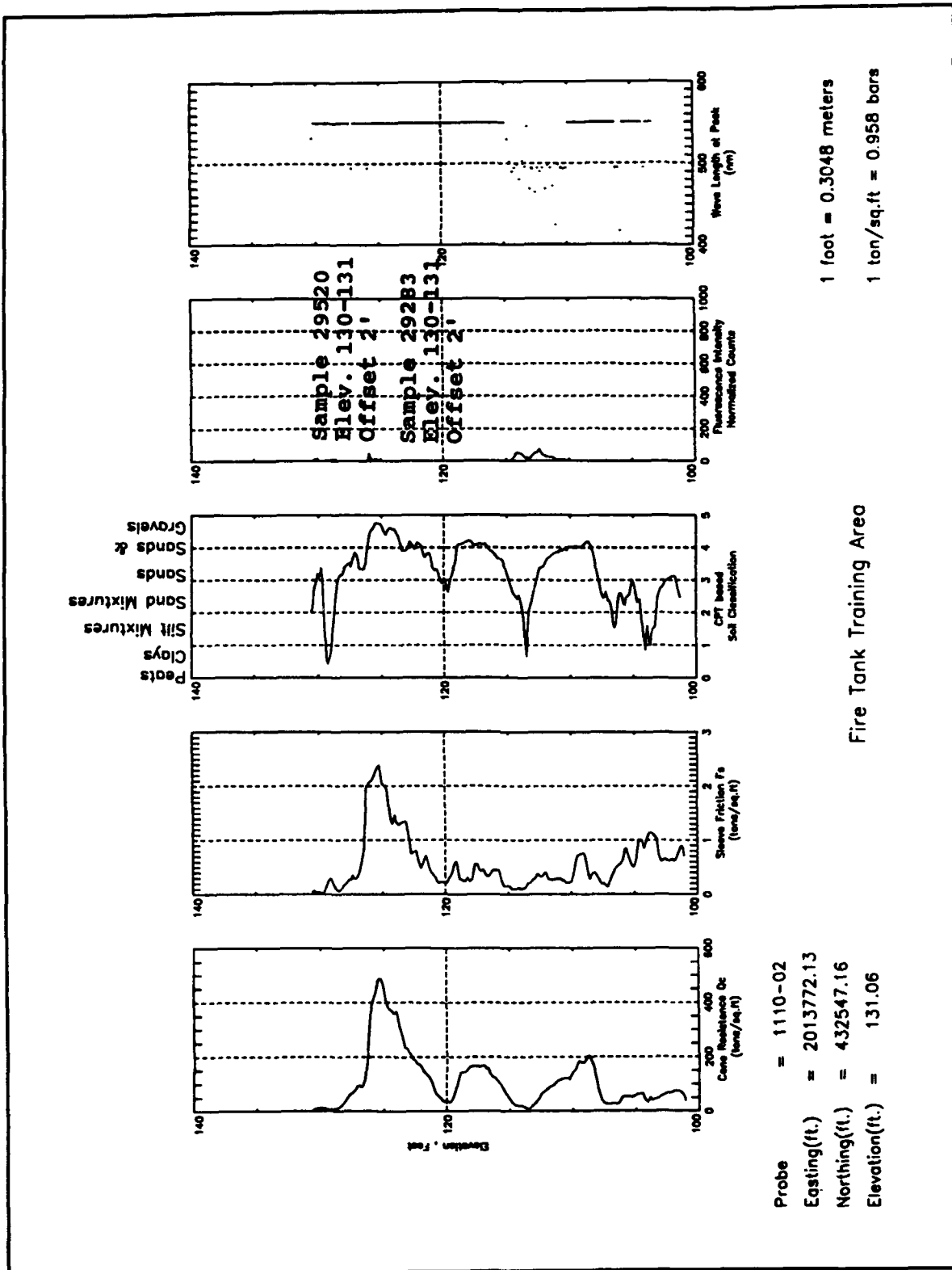

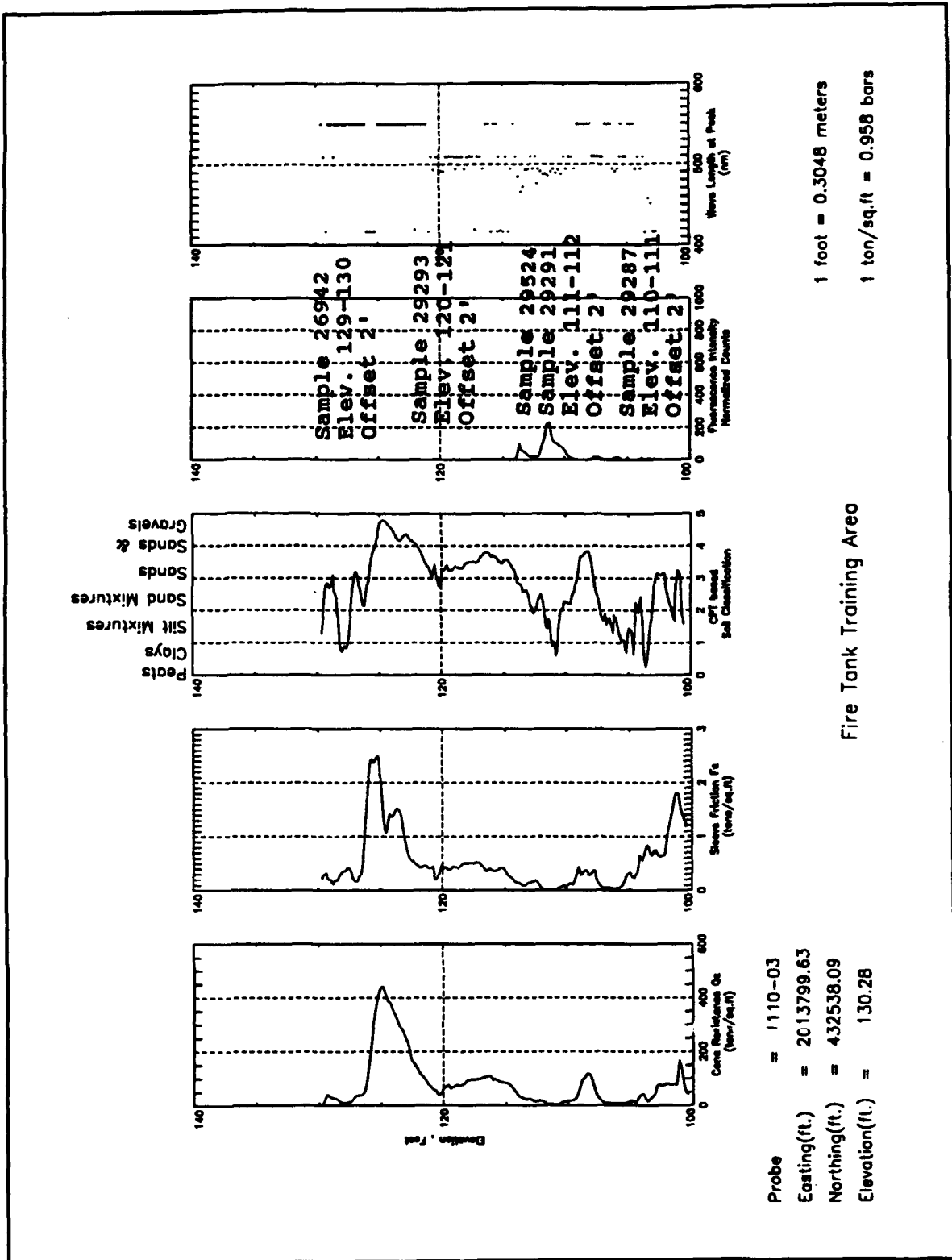

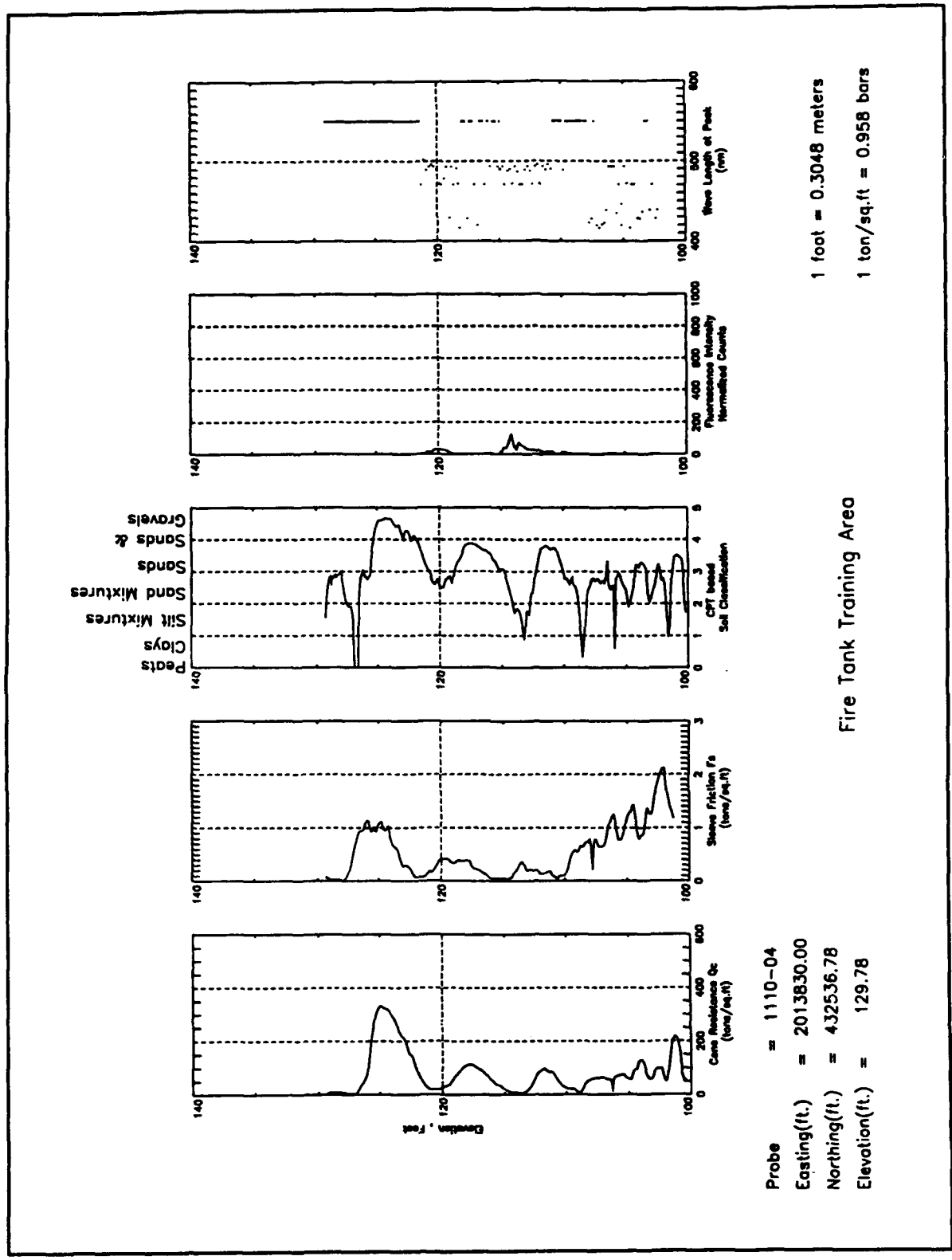

Probe = 1110-04
 Easting(ft.) = 2013830.00
 Northing(ft.) = 432536.78
 Elevation(ft.) = 129.78

Fire Tank Training Area

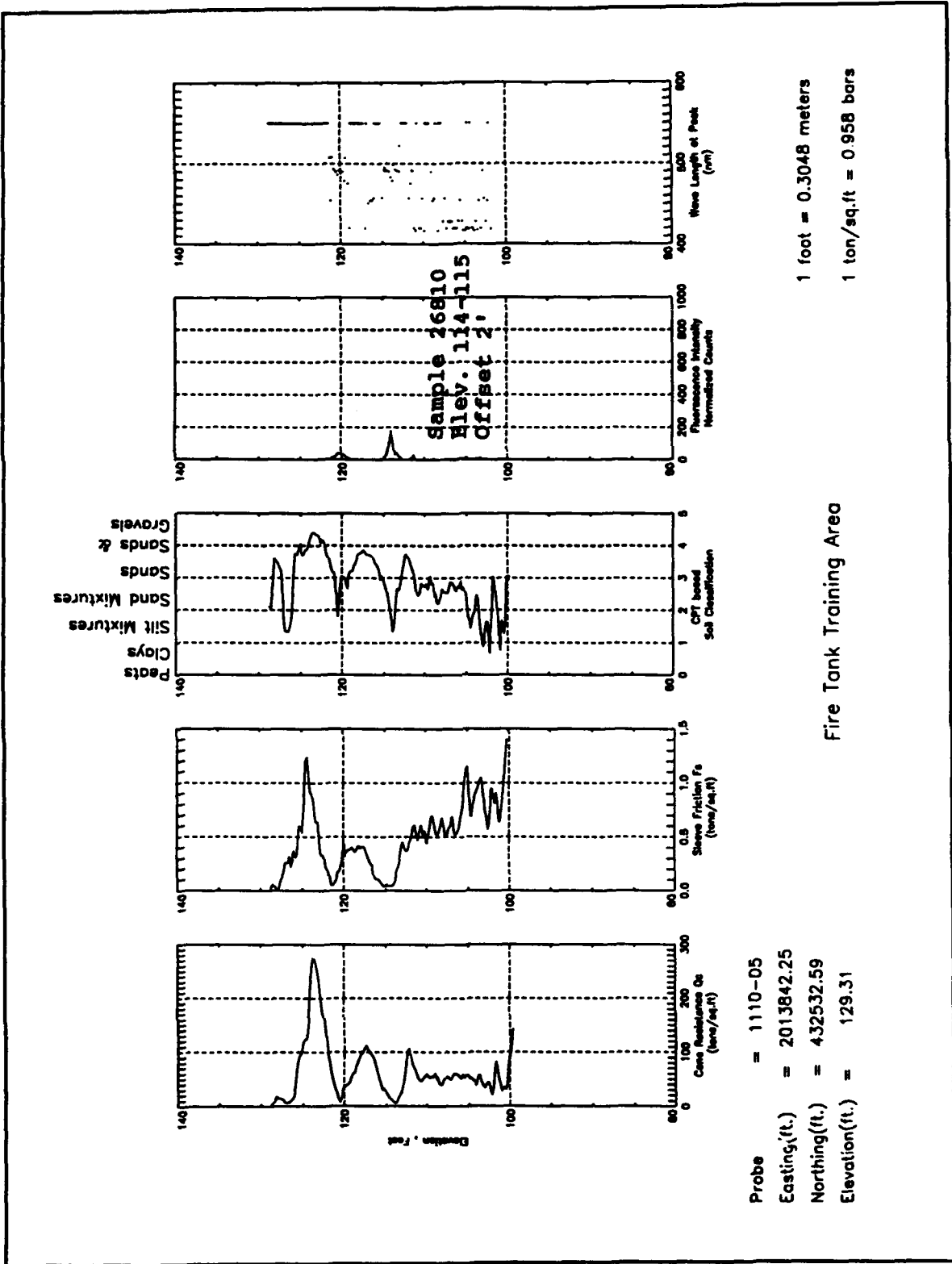

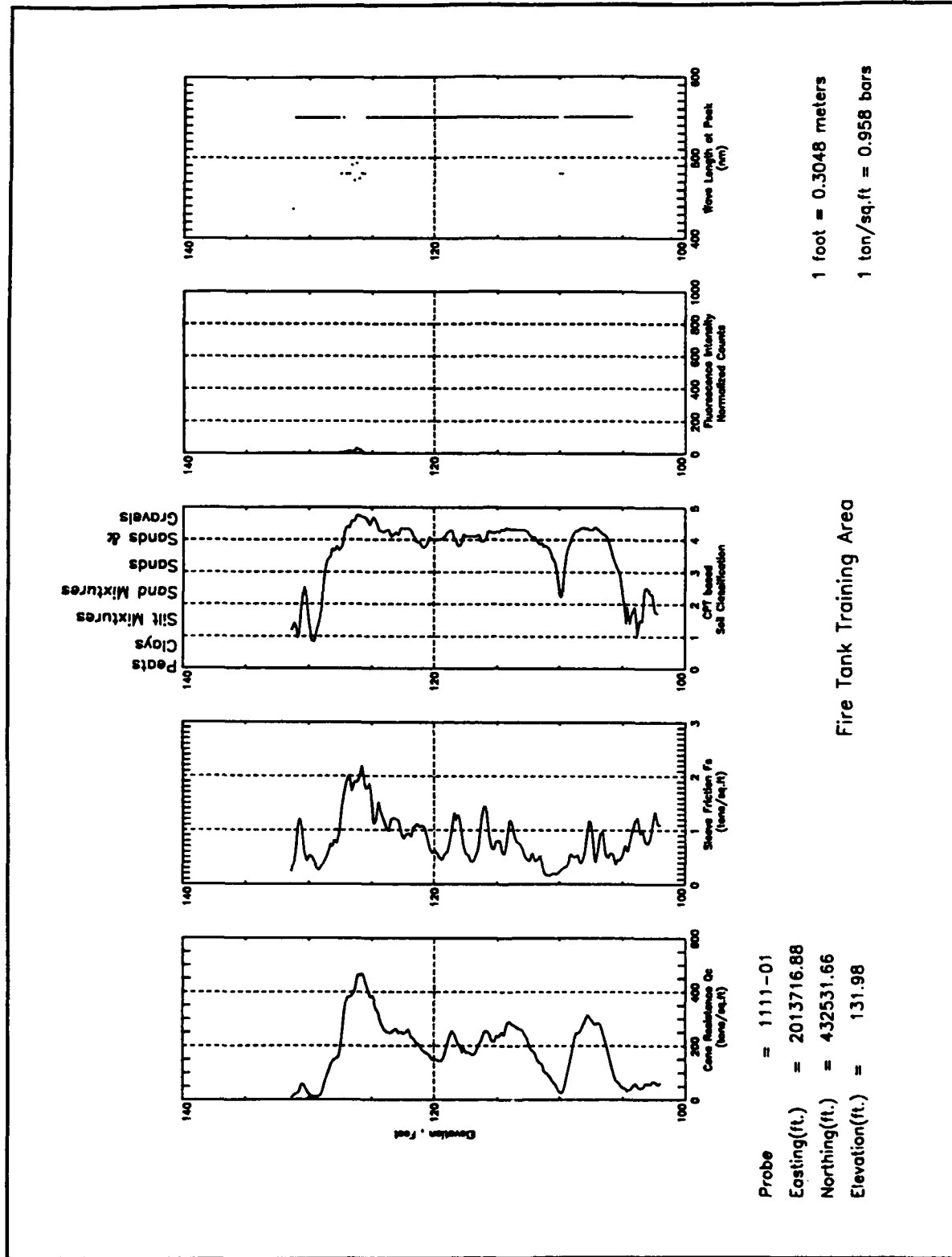

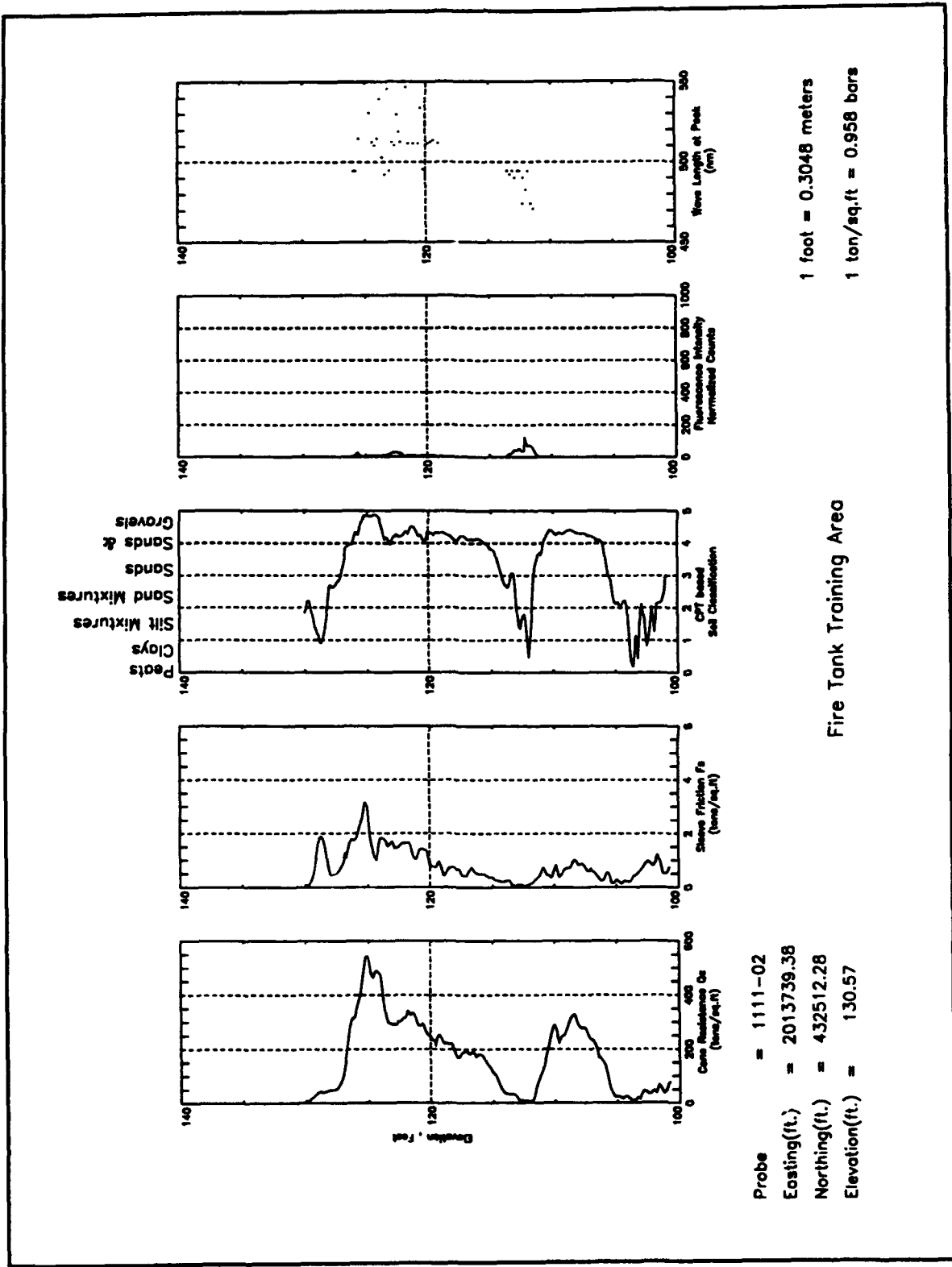

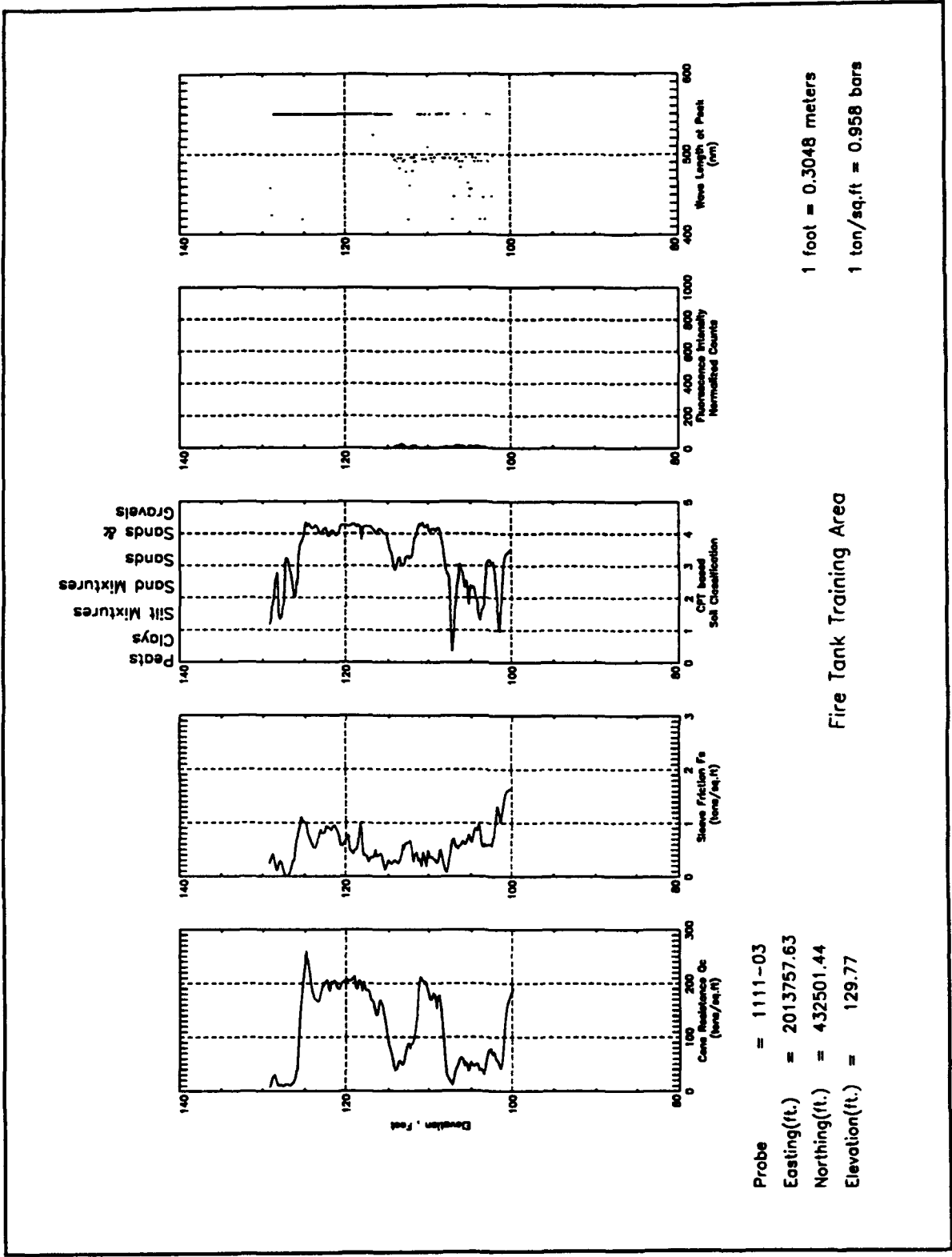

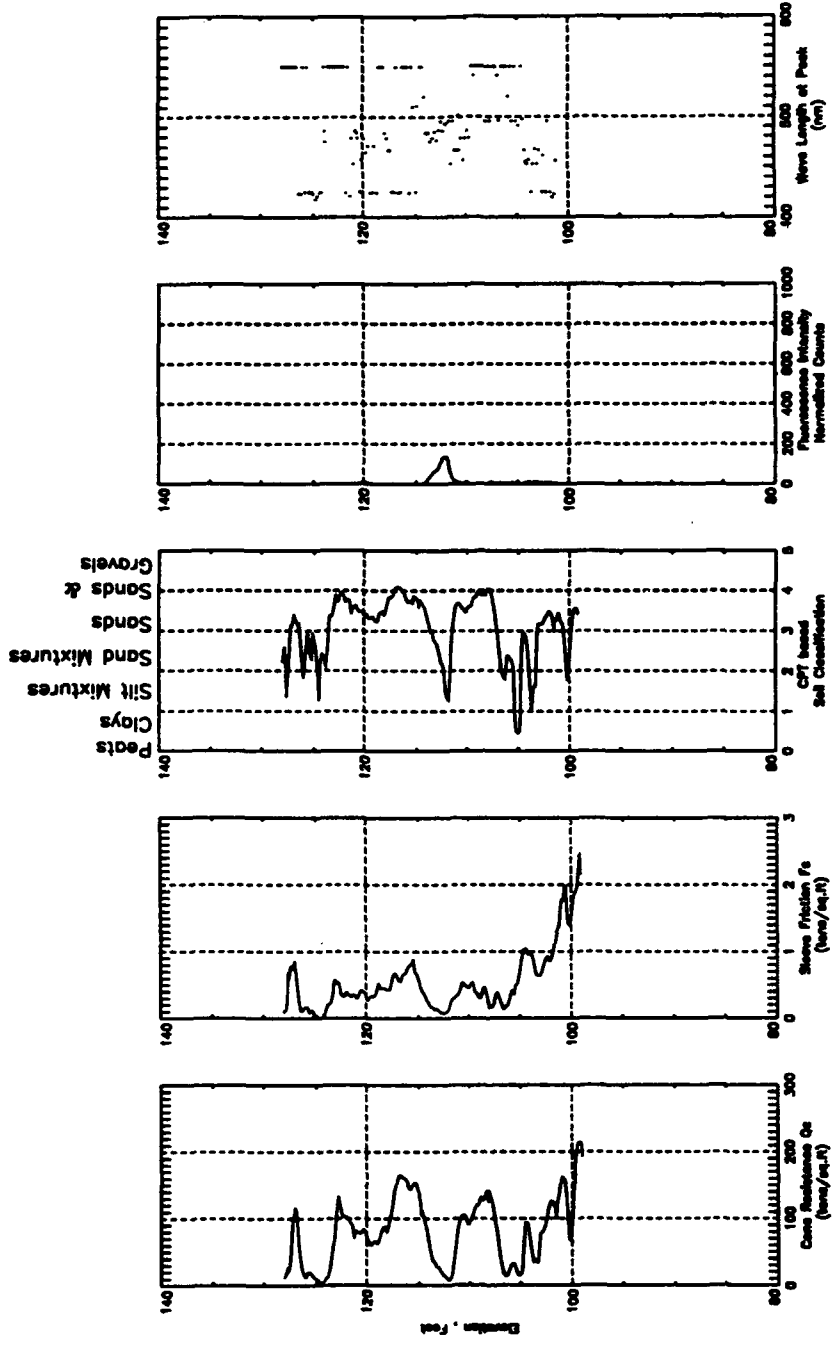

Probe = 1111-04
 Easting(ft.) = 2013791.00
 Northing(ft.) = 432483.16
 Elevation(ft.) = 128.65

1 foot = 0.3048 meters
 1 ton/sq.ft = 0.958 bars

Fire Tank Training Area

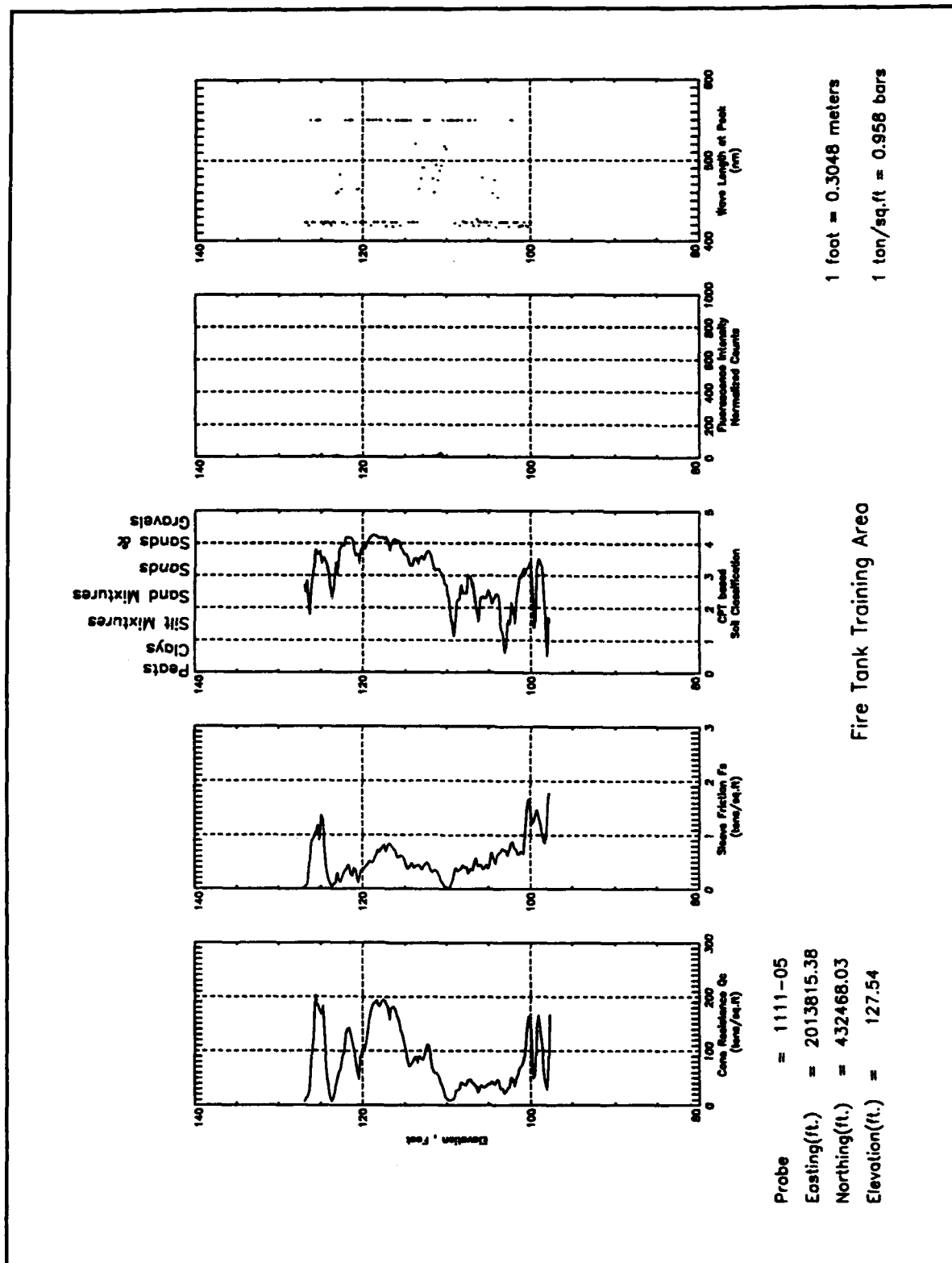

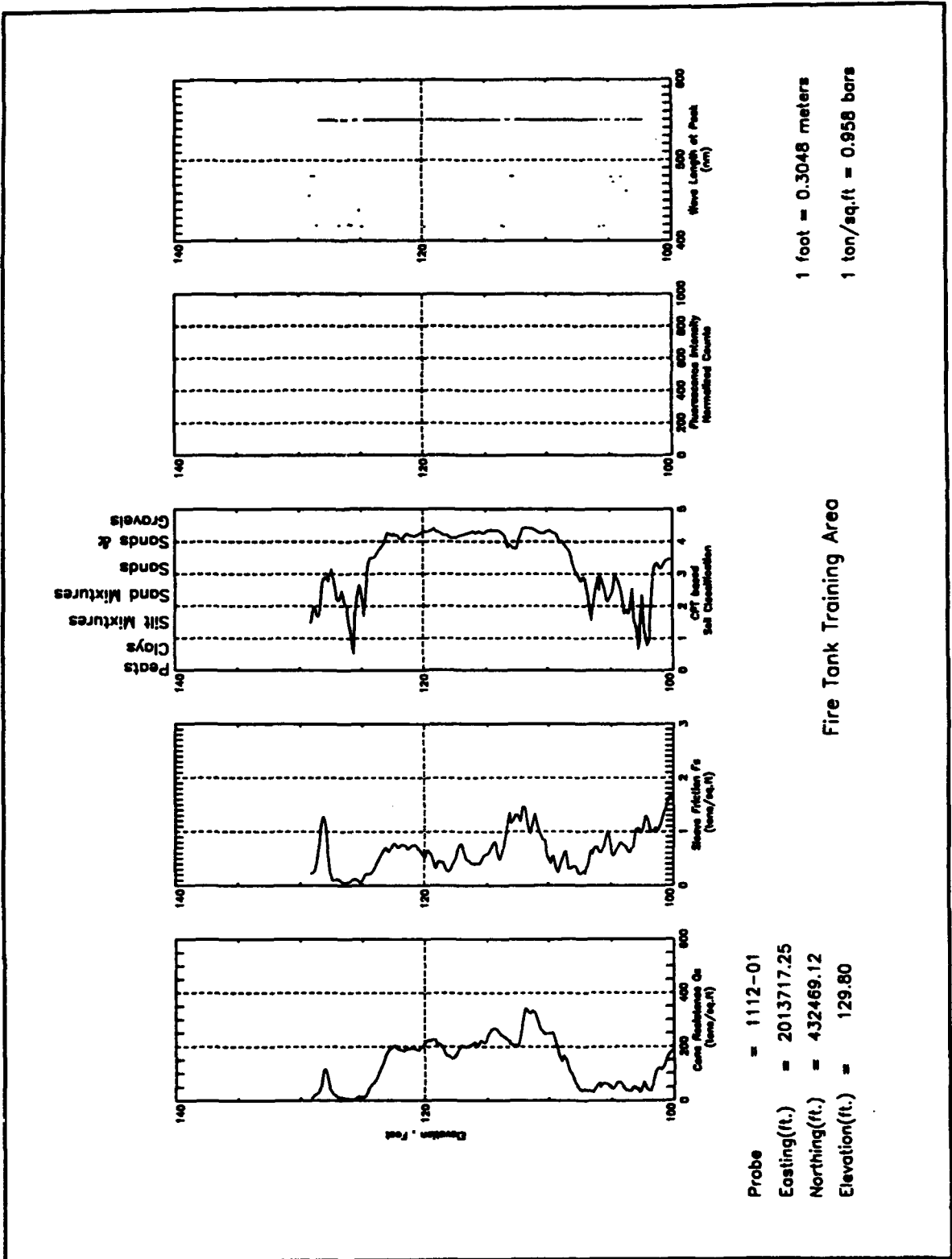

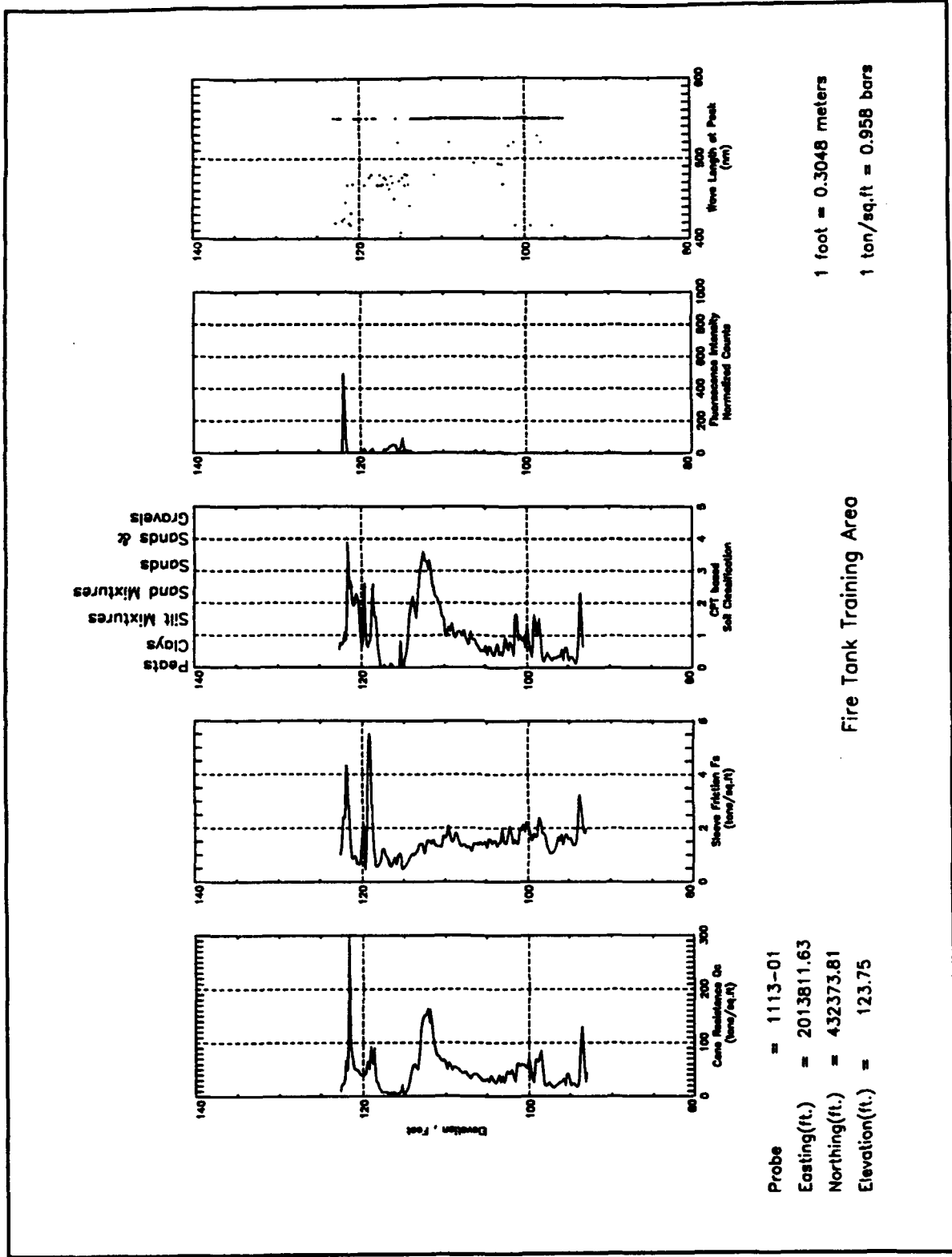

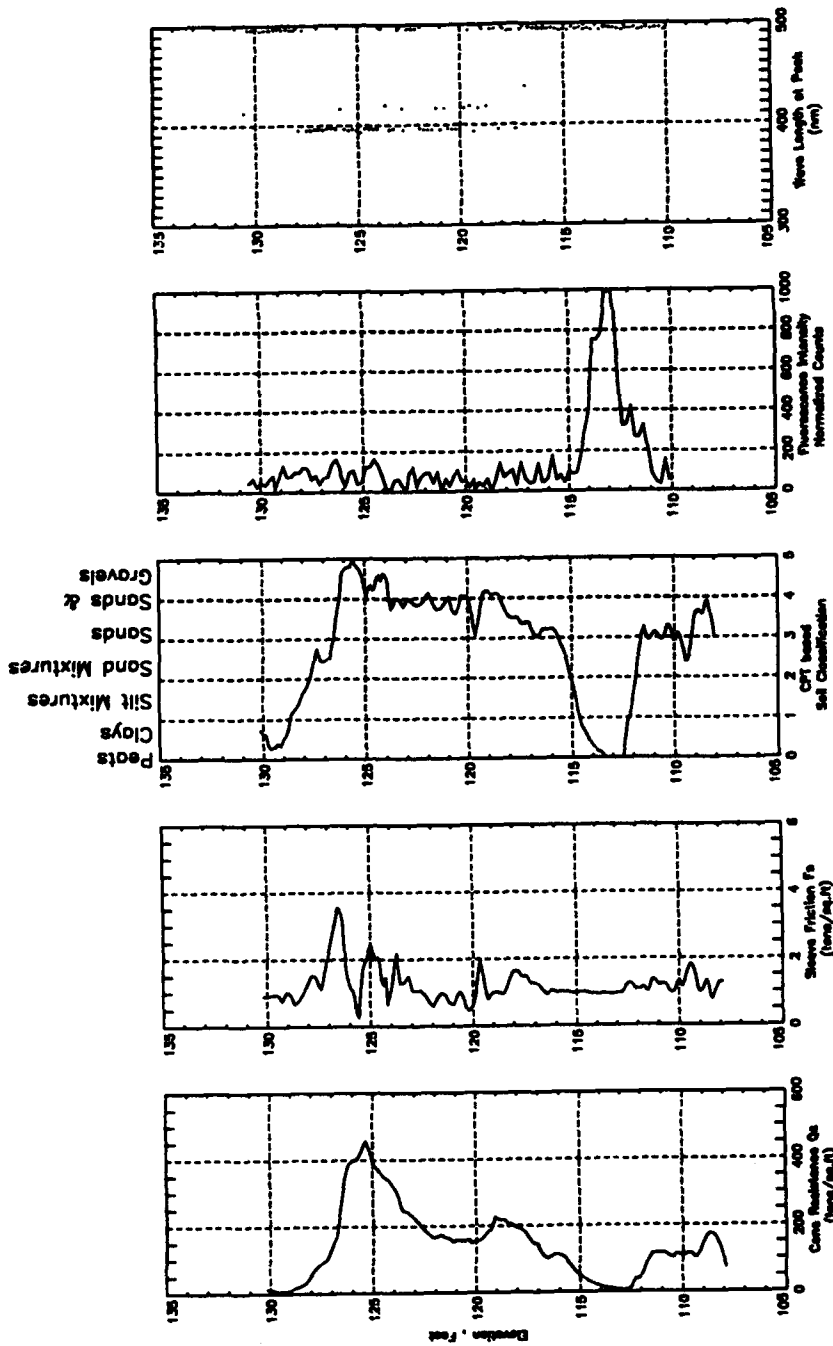

Probe = 1114-01
 Easting(ft.) = 2013771.88
 Northing(ft.) = 432548.09
 Elevation(ft.) = 131.25

Fire Tank Training Area

1 foot = 0.3048 meters
 1 ton/sq.ft = 0.958 bars

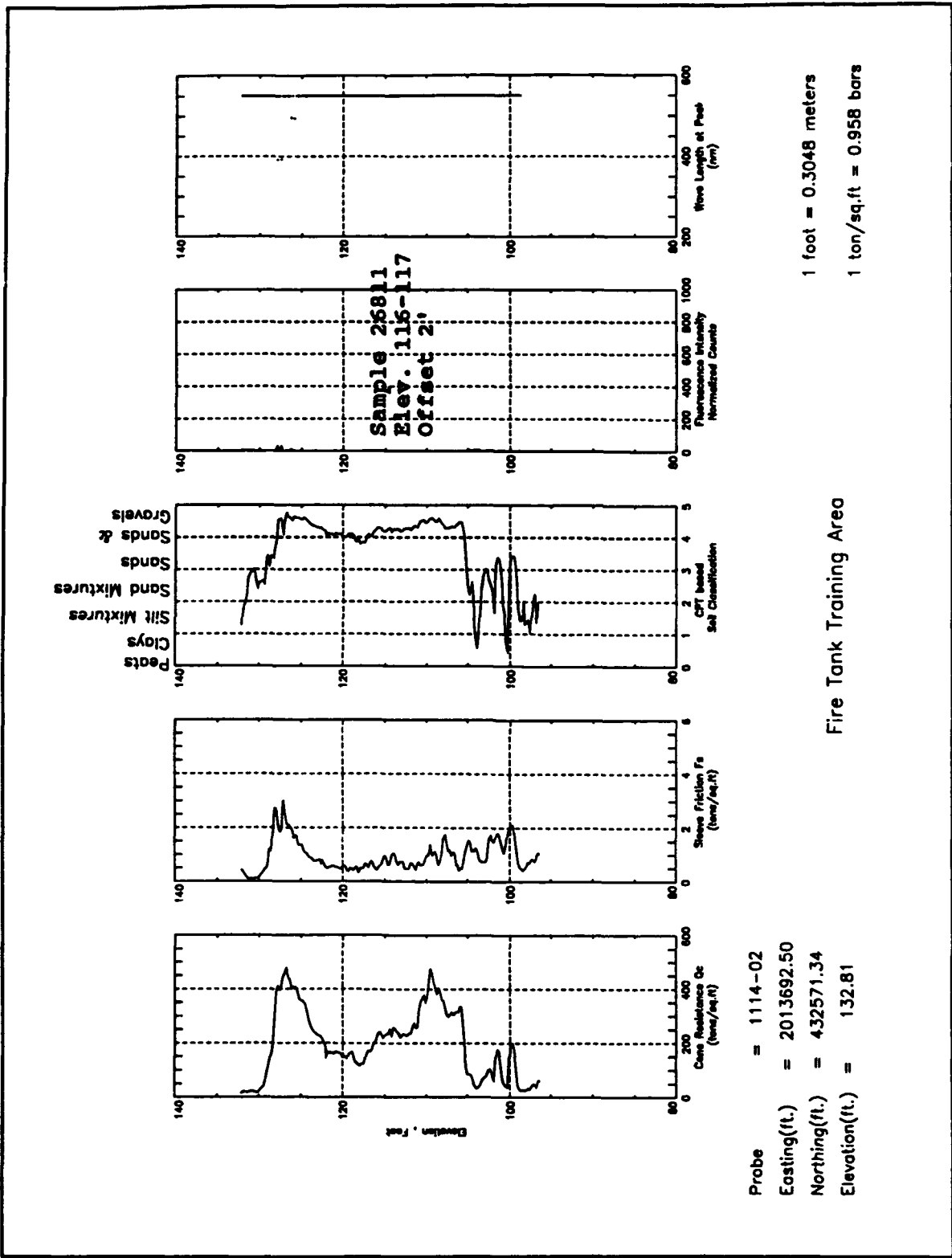

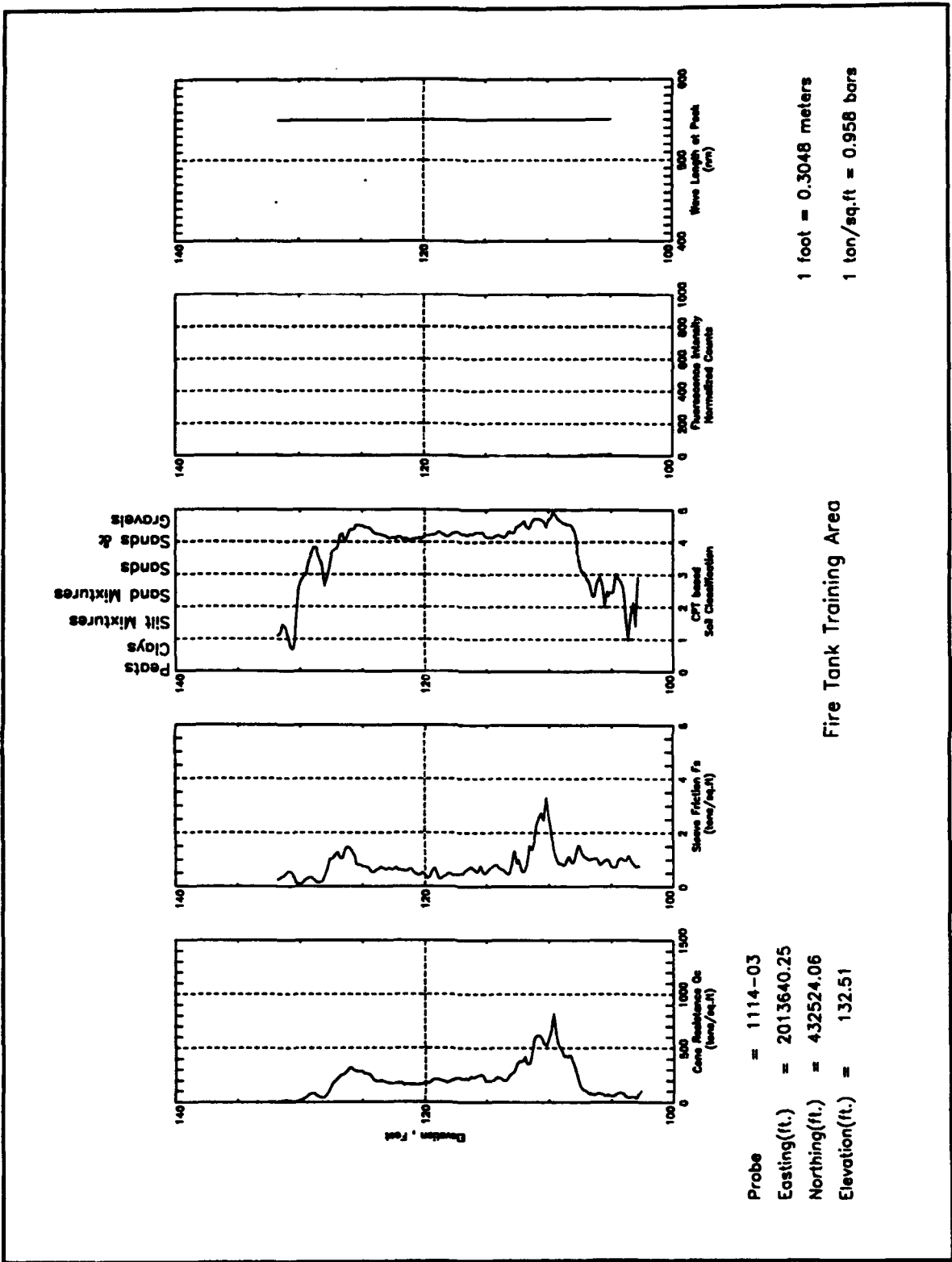

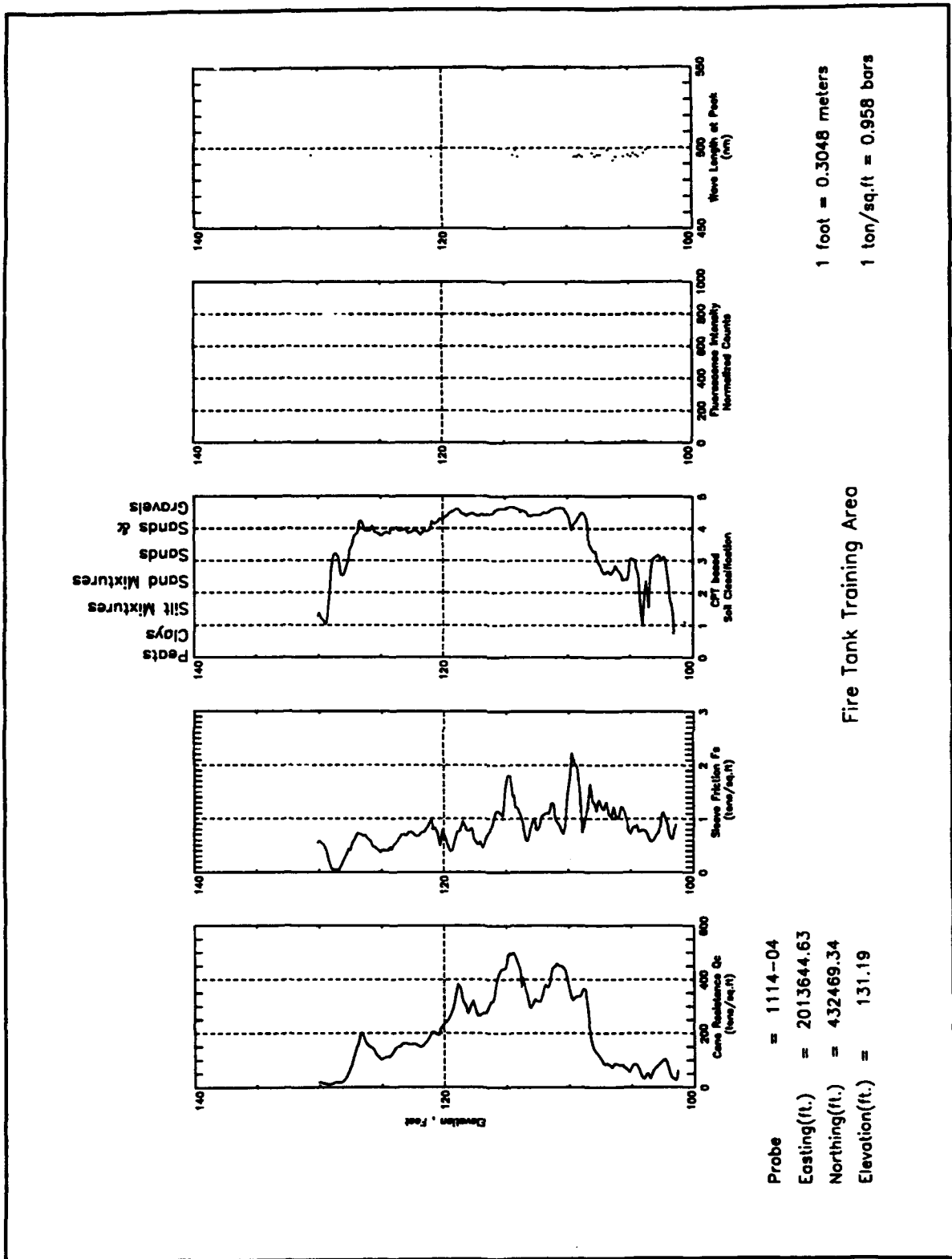

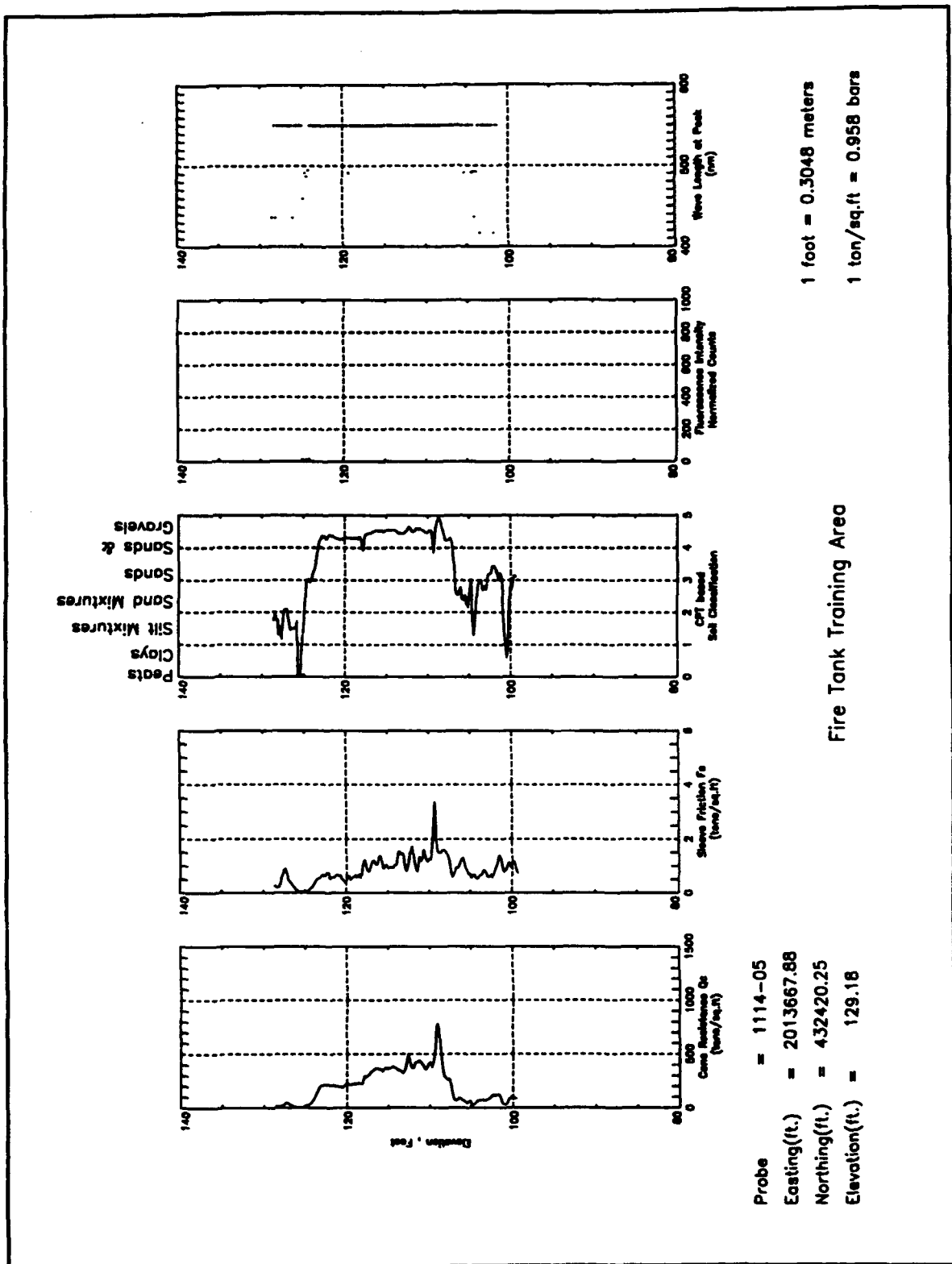

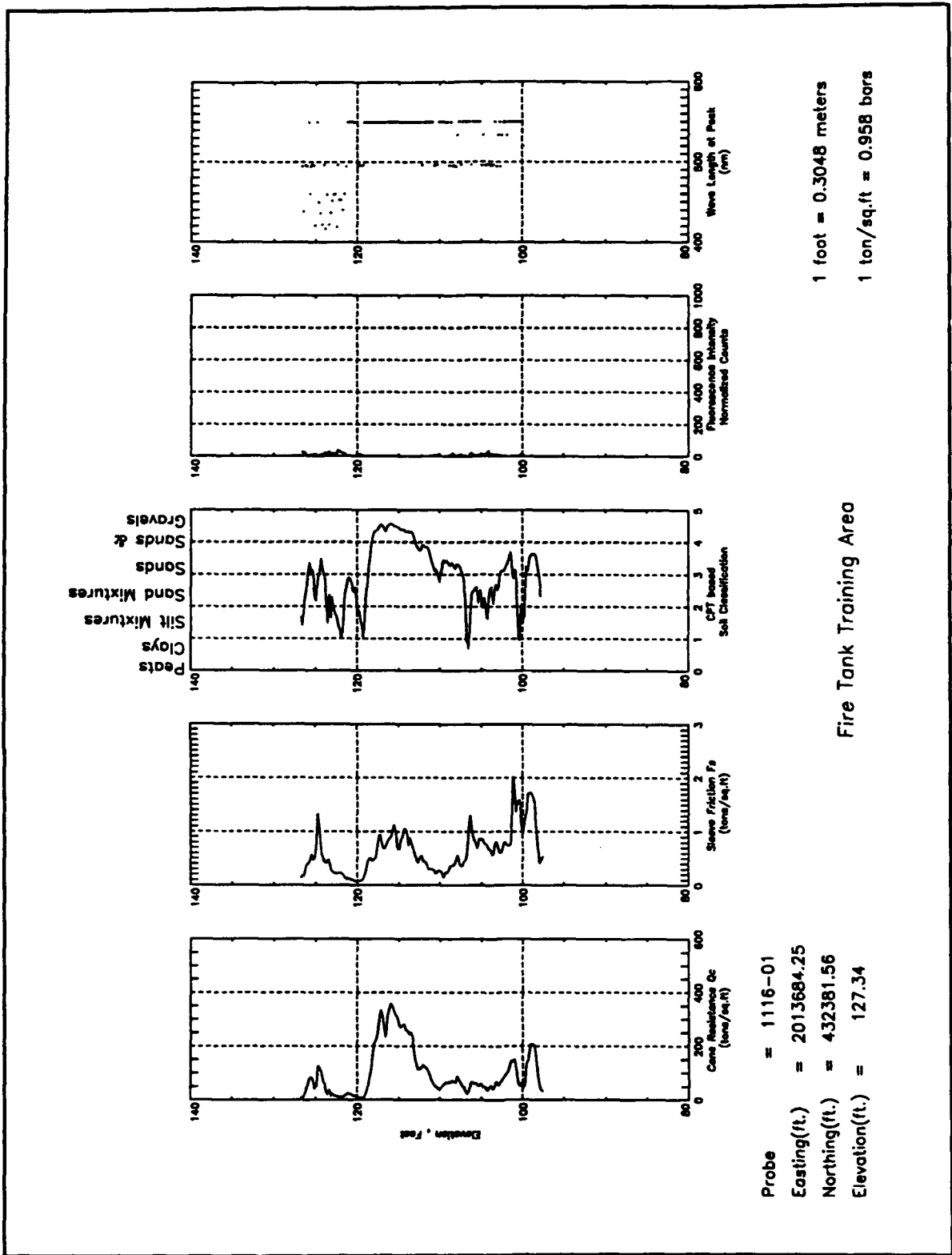

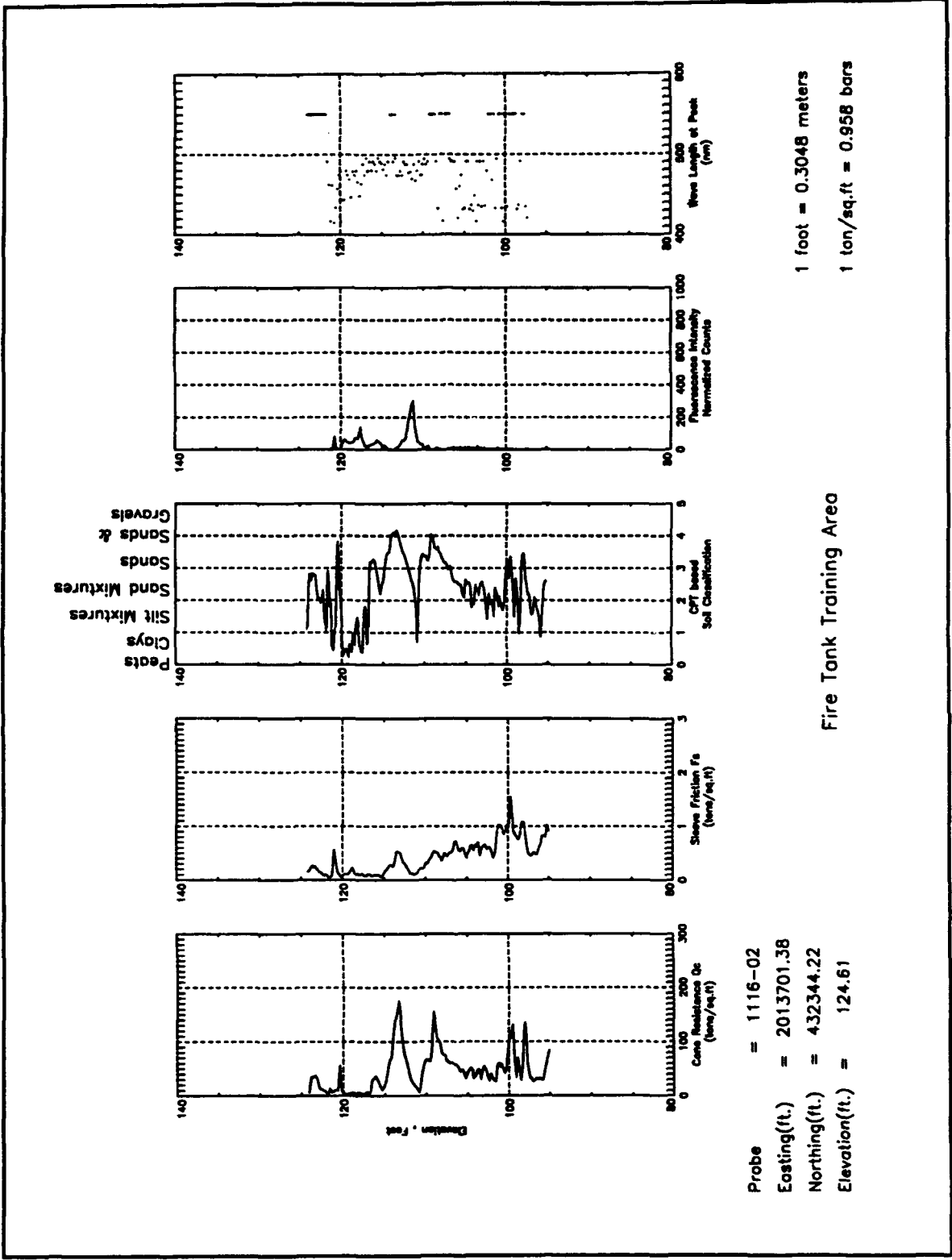

Probe = 1116-02
 Easting(ft.) = 2013701.38
 Northing(ft.) = 432344.22
 Elevation(ft.) = 124.61

1 foot = 0.3048 meters
 1 ton/sq.ft = 0.958 bars

Fire Tank Training Area

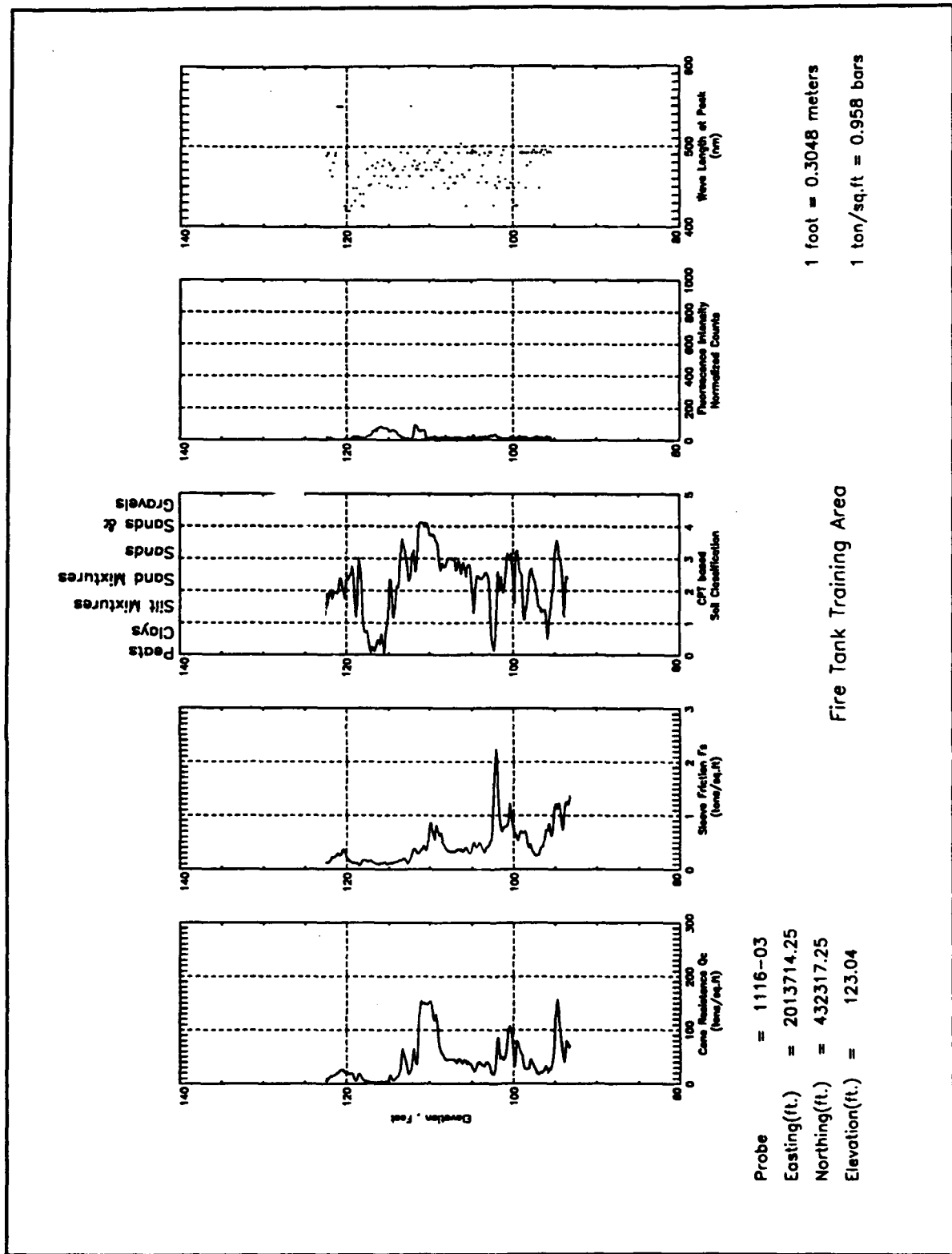

Appendix C

4300 Area Motor Pool

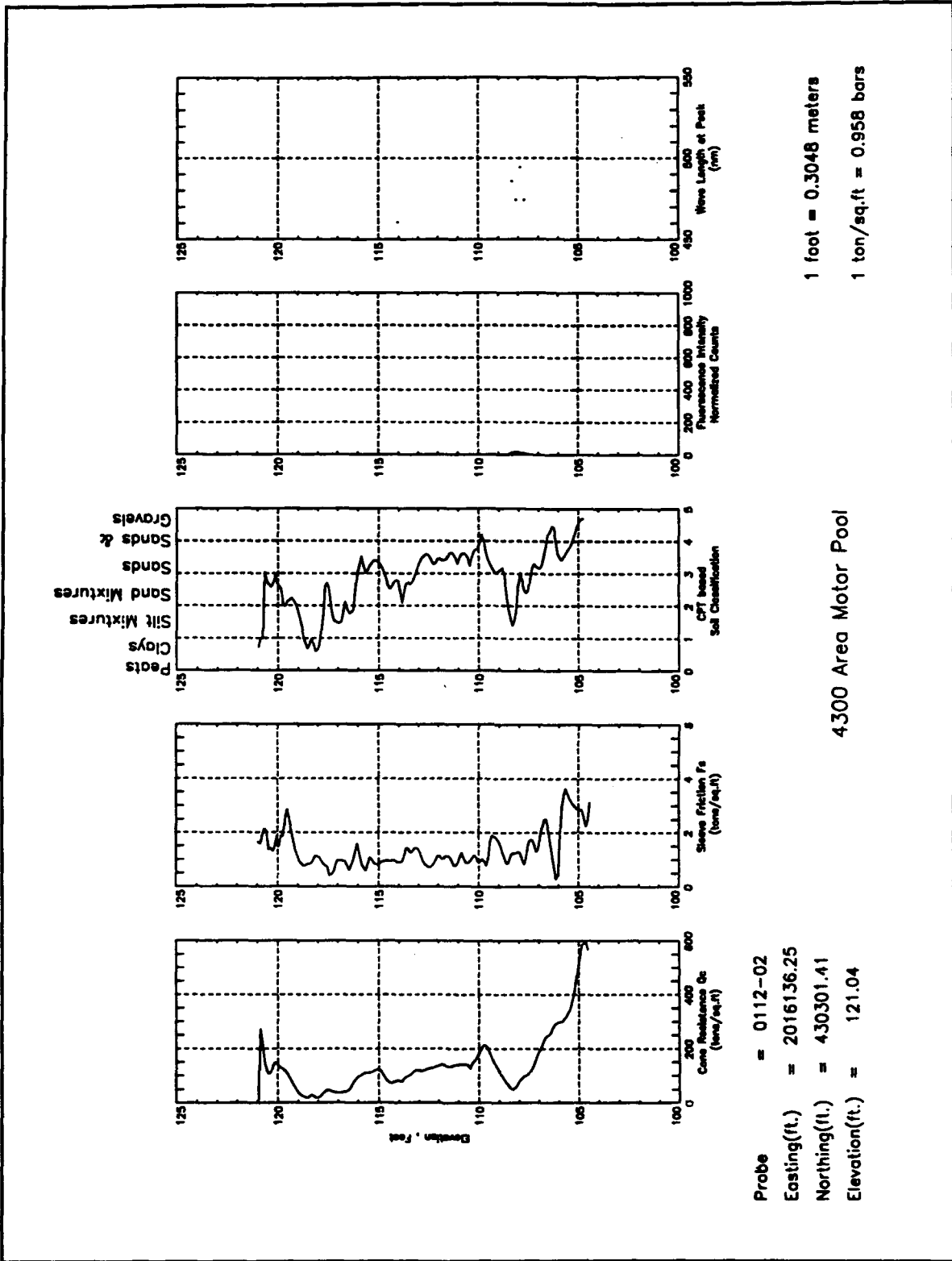

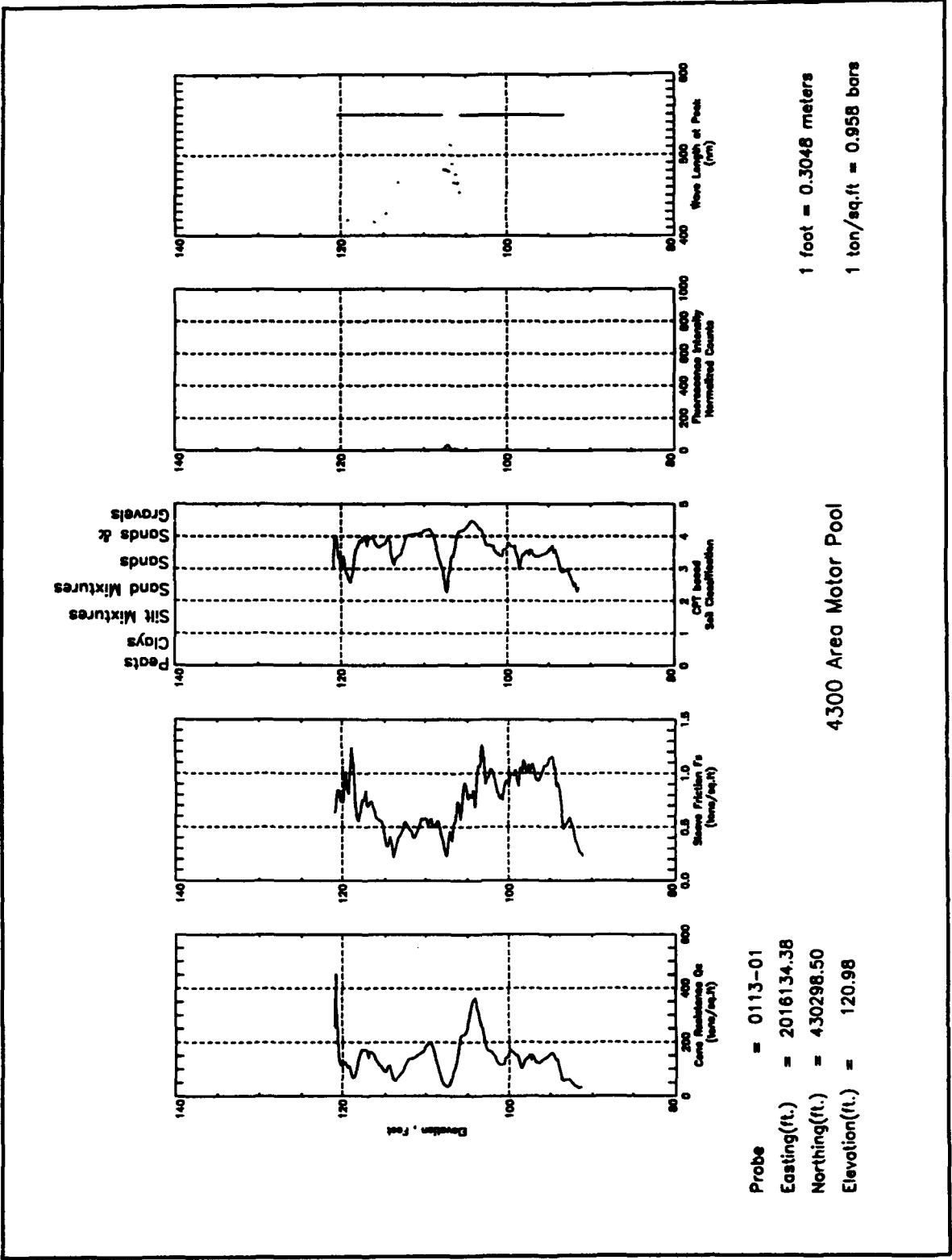

Probe = 0113-01
 Easting(ft.) = 2016134.38
 Northing(ft.) = 430298.50
 Elevation(ft.) = 120.98

1 foot = 0.3048 meters
 1 ton/sq.ft = 0.958 bars

4300 Area Motor Pool

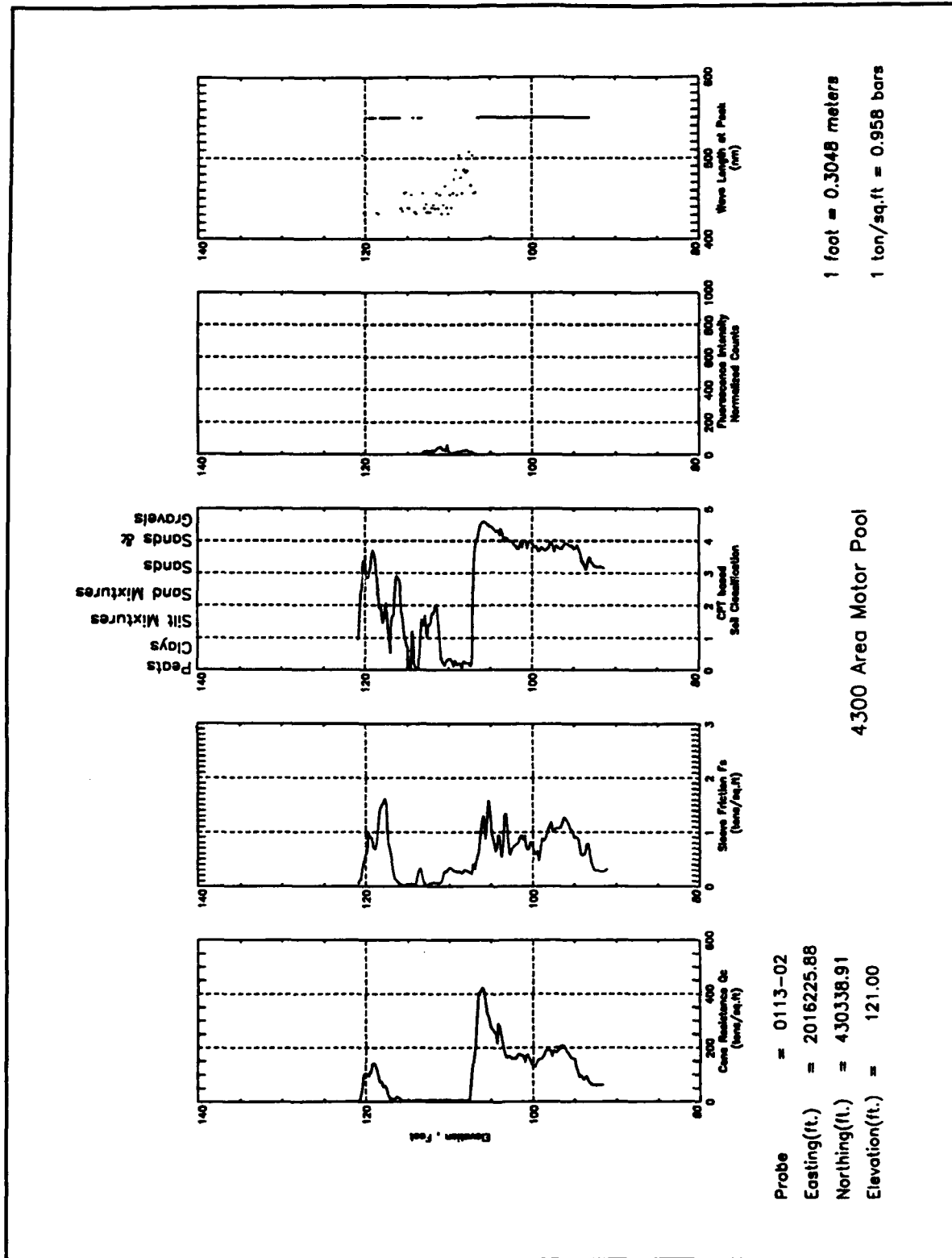

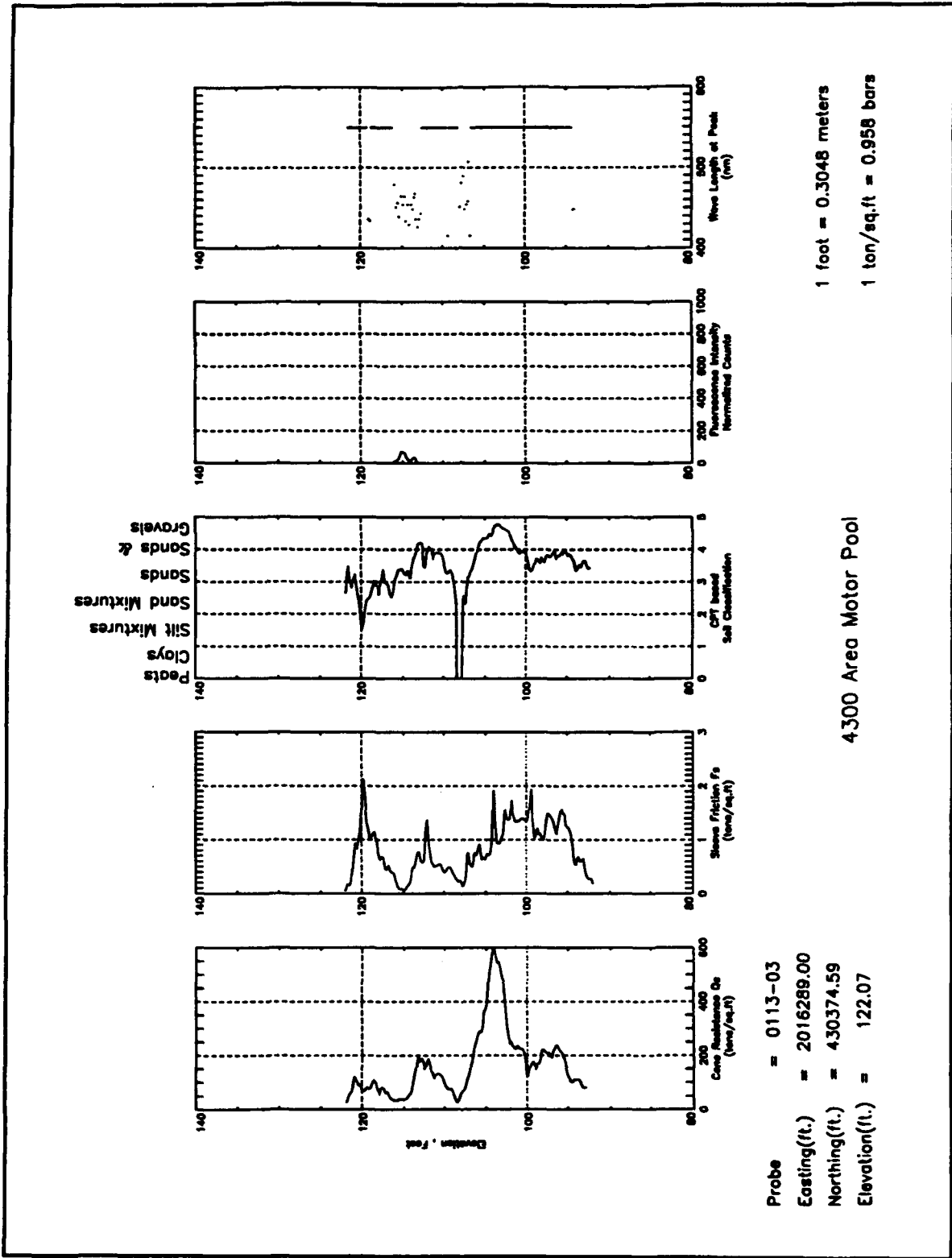

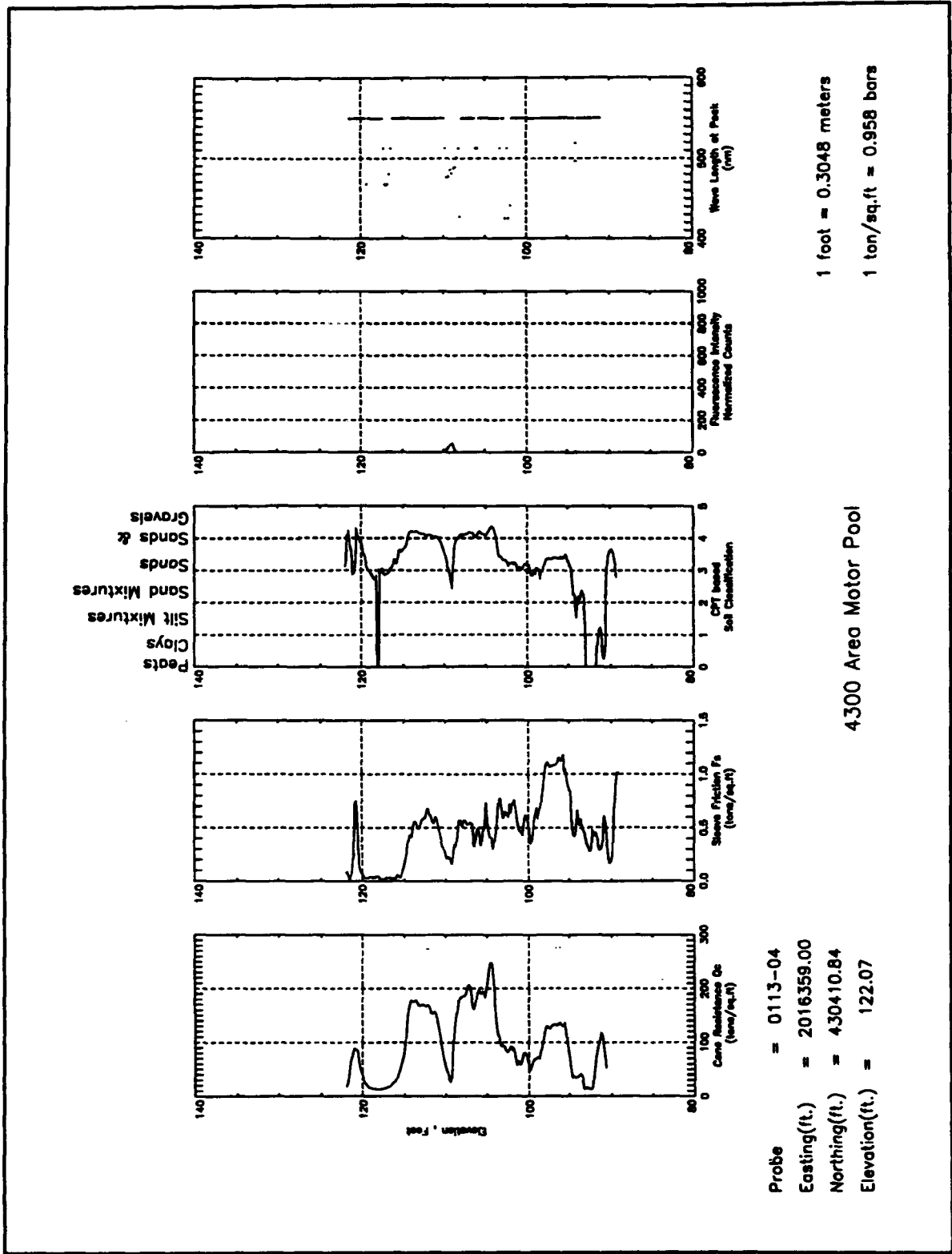

Probe = 0113-04
 Easting(ft.) = 2016359.00
 Northing(ft.) = 430410.84
 Elevation(ft.) = 122.07

4300 Area Motor Pool

1 foot = 0.3048 meters
 1 ton/sq.ft = 0.958 bars

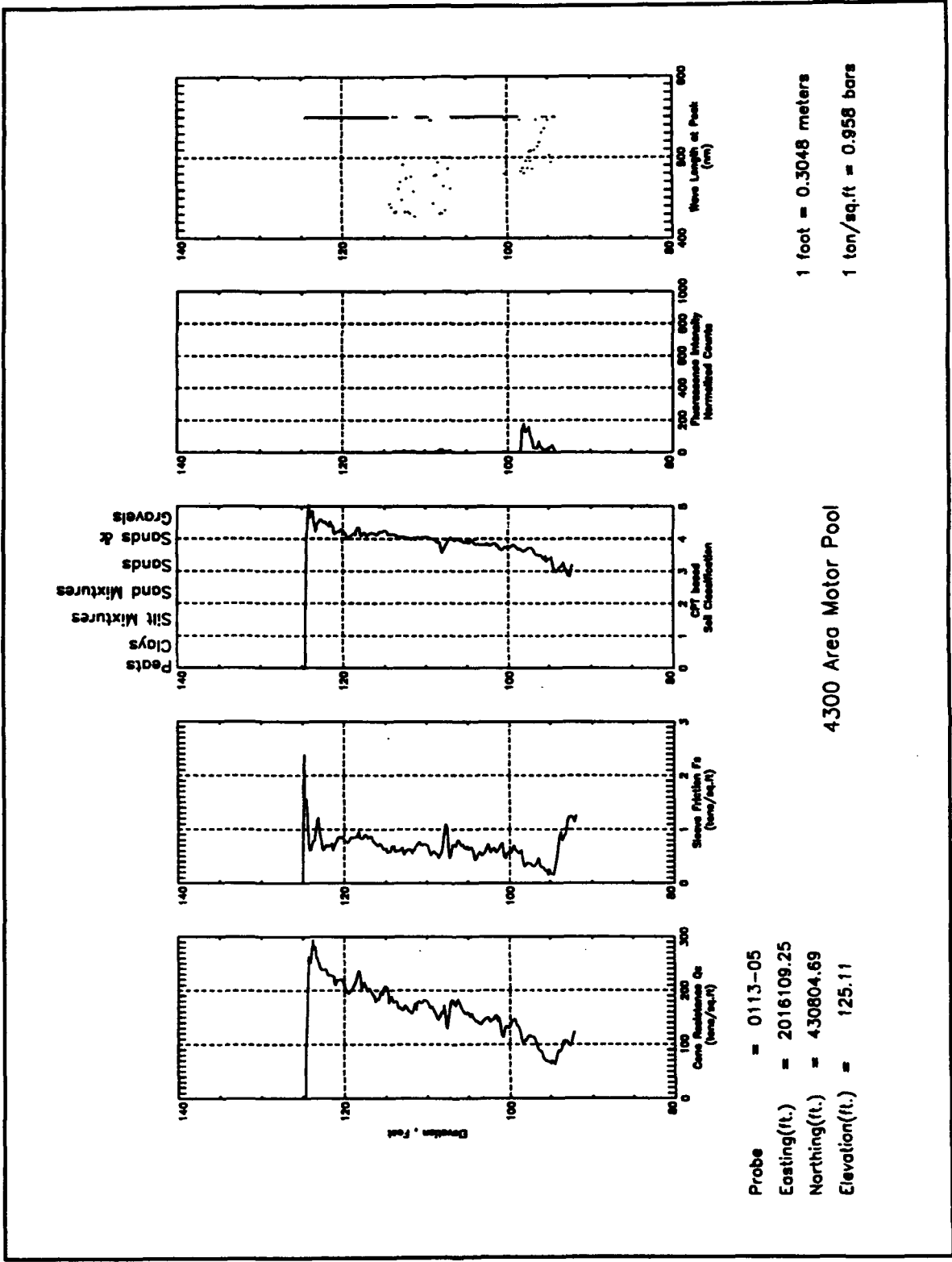

Probe = 0113-05
 Easting(ft.) = 2016109.25
 Northing(ft.) = 430804.69
 Elevation(ft.) = 125.11

4300 Area Motor Pool

1 foot = 0.3048 meters
 1 ton/sq.ft = 0.958 bars

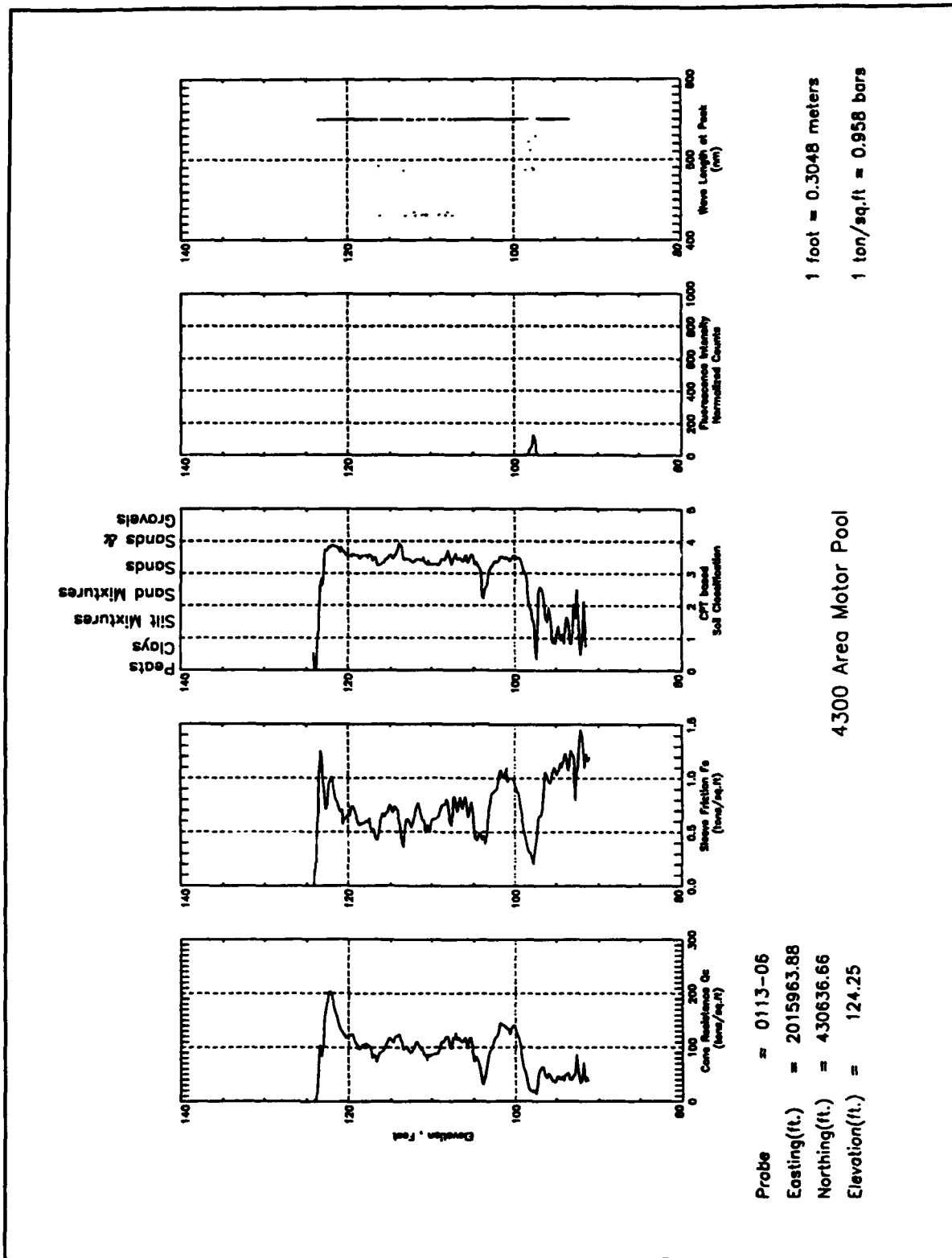

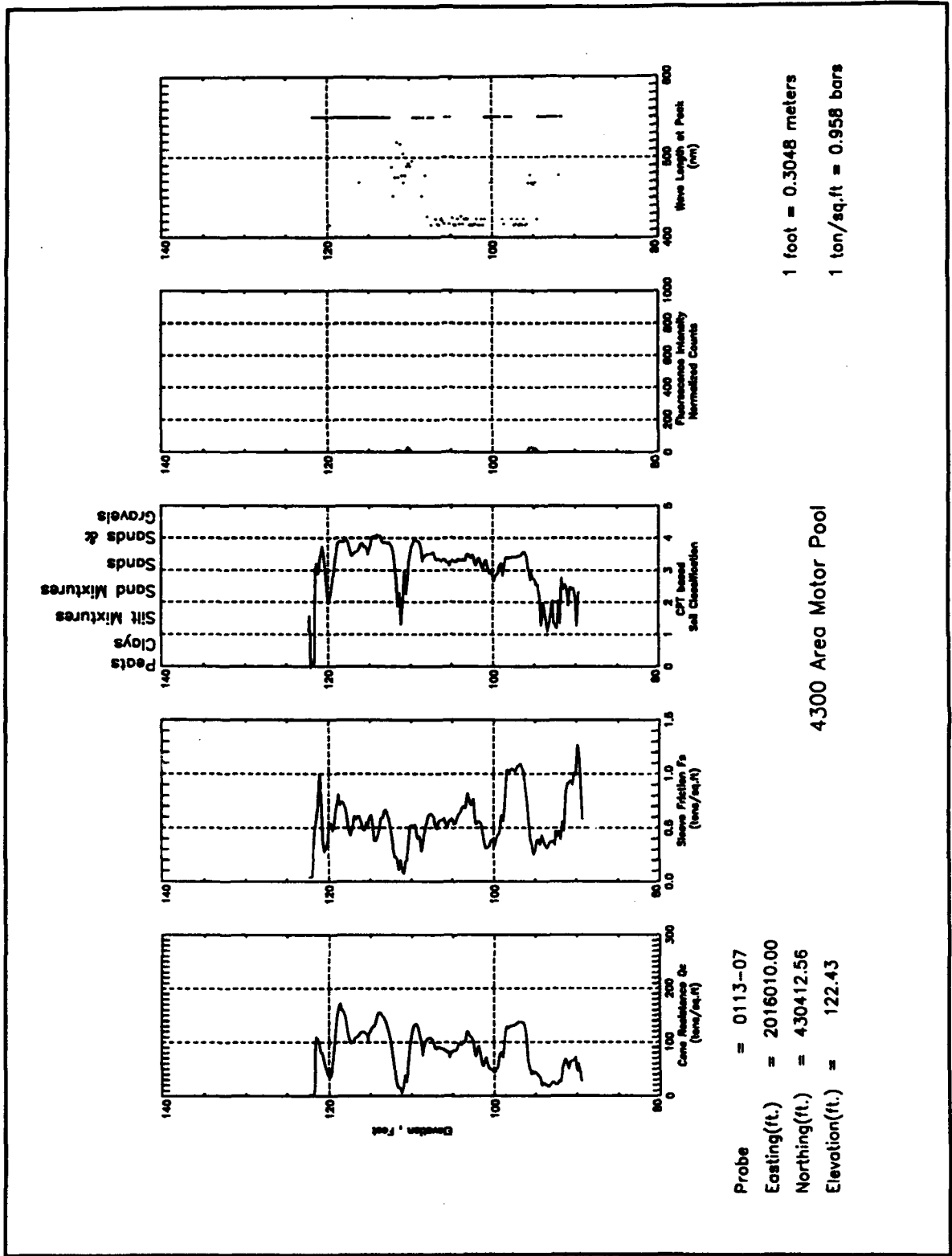

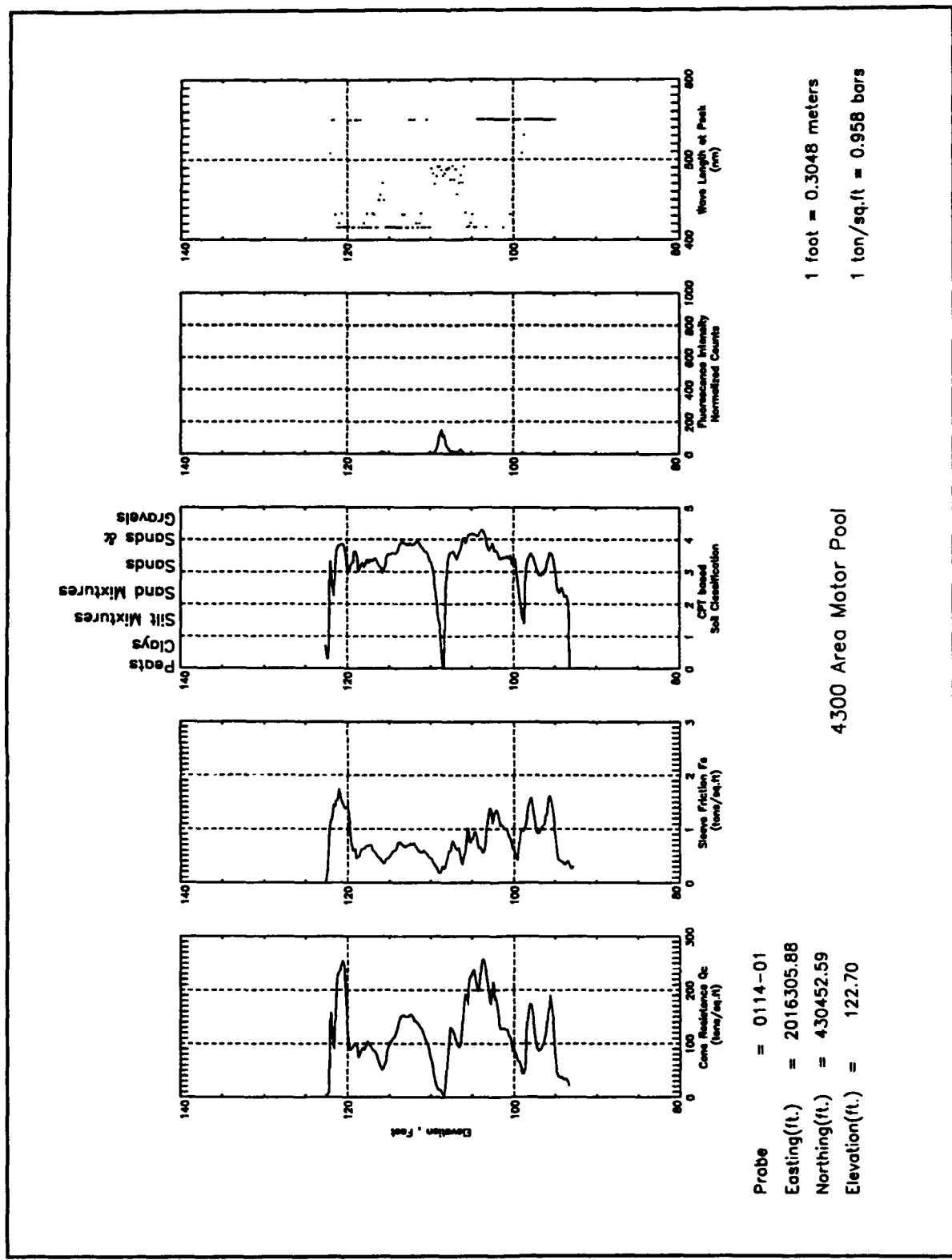

Appendix D

4400 Area Motor Pool

**Verification Sample Information
4400 Area Motor Pool**

Sample No.	27875	29294	27493	27492
Type	Water	Water	Concrete	Soil
Lab Method	418.1/415.1	418.1/415.1	418.1	418.1
TRPH, ppm	<0.5	0.1	6	<25
Other, ppm	4.8 (TOC)	35 (TOC)	—	—
Easting, ft	2017108	2017671	2017479.7	2017733
Northing, ft	428365	428421	427239.9	428229
Elevation Range ft MSL	121-122	98-99	143	124-125
Sample Fluoresced?	YES	NO	YES	YES
Maximum Intensity, counts	14	0	24	13
Peak Wavelength, nm	422	585	407	415
Nearest Probe	0118-02	1130-05	1205-02	1130-01
Easting, ft	2017107	2017670	2017479.7	2017731.6
Northing, ft	428364.1	428420.4	427239.9	428228.2
Offset from Sample, ft	2	2	0	2
Soil Classification at Sample Elevation	Sand/Gravel	Sand	Sand	Sand/Silt
Intensity Range counts	0	0-25	0-450	0-50
Peak Wavelength, nm	N/A	410	490	410
<p>TRPH = Total Recoverable Petroleum Hydrocarbons. PAH = Polynuclear Aromatic Hydrocarbons. TOC = Total Organic Carbon. OG = Oil and Grease. ppm = parts per million. Lab Method = USEPA SW-846, 1984.</p>				
<i>(Sheet 1 of 6)</i>				

**Verification Sample Information
4400 Area Motor Pool (Continued)**

Sample No.	29289	29288	31391	31392
Type	Soil	Soil	Soil	Soil
Lab Method	418.1/415.1	418.1/415.1	418.1/413.2	418.1/413.2
TRPH, ppm	<25	<25	430	7900
Other, ppm	1578(TOC)	1258(TOC)	460(OG)	8200(OG)
Easting, ft	2017671	2017671	2016955	2016955
Northing, ft	428421	428421	429110	429110
Elevation Range ft MSL	120-121	115-116	118.4-118.8	118-118.4
Sample Fluoresced?	YES	YES	YES	YES
Maximum Intensity, counts	27	12	170	517
Peak Wavelength (nanometers)	478	464	429	409
Nearest Probe	1130-05	1130-05	0116-01	0116-01
Easting, ft	2017670	2017670	2016954.6	2016954.6
Northing, ft	428420.4	428420.4	429109.6	429109.6
Offset from Sample, ft	2	2	2	2
Soil Classification at Sample Elevation	Clay	Sand	Sand	Sand
Intensity Range counts	0	0-100	0-200	200-800
Peak Wavelength, nm	N/A	490	410	410

TRPH = Total Recoverable Petroleum Hydrocarbons.
 PAH = Polynuclear Aromatic Hydrocarbons.
 TOC = Total Organic Carbon.
 OG = Oil and Grease.
 ppm = parts per million.
 Lab Method = USEPA SW-846, 1984.

(Sheet 2 of 6)

Verification Sample Information 4400 Area Motor Pool (Continued)				
Sample No.	31391	39392	31393	31394
Type	Soil	Soil	Soil	Soil
Lab Method	8270	8270	8270	8270
TRPH, ppm				
Other, ppm	PAH-Table 7	PAH-Table 7	PAH-Table 7	PAH-Table 7
Easting, ft	2016955	2016955	2017733	2017733
Northing, ft	429110	429110	428229	428229
Elevation Range ft MSL	118.4-118.8	118-118.4	125-126	126-126.5
Sample Fluoresced?	YES	YES	YES	YES
Maximum Intensity, counts	170	517	10	132
Peak Wavelength, nm	429	409	481	444
Nearest Probe	0116-01	0116-01	1130-01	1130-01
Easting, ft	2016954.6	2016954.6	2017731.6	20177331.6
Northing, ft	429109.6	429109.6	428228.2	428228.2
Offset from Sample, ft	2	2	2	2
Soil Classification at Sample Elevation	Sand	Sand	Silt	Silt
Intensity Range counts	0-200	200-800	0-200	0-200
Peak Wavelength, nm	410	410	410	410
<p>TRPH = Total Recoverable Petroleum Hydrocarbons. PAH = Polynuclear Aromatic Hydrocarbons. TOC = Total Organic Carbon. OG = Oil and Grease. ppm = parts per million. Lab Method = USEPA SW-846, 1984.</p>				
<i>(Sheet 3 of 6)</i>				

Verification Sample Information 4400 Area Motor Pool (Continued)				
Sample No.	31393	31394	31395	31396
Type	Soil	Soil	Soil	Soil
Lab Method	418.1/413.2	418.1/413.2	418.1/413.2	418.1/413.2
TRPH, ppm	25	3100	1800	2100
Other, ppm	110(OG)	3200(OG)	1900(OG)	2200(OG)
Easting, ft	2017733	2017733	2017733	2017733
Northing, ft	428229	428229	428229	428229
Elevation Range ft MSL	127-128	126-126.5	122.7-123.2	122-122.5
Sample Fluoresced?	YES	YES	YES	YES
Maximum Intensity, counts	10	132	174	158
Peak Wavelength, nm	481	444	409	413
Nearest probe	1130-01	1130-01	1130-01	1130-01
Easting, ft	2017731.6	2017731.6	2017731.6	2017731.6
Northing, ft	428228.2	428228.2	428228.2	428228.2
Offset from Sample, ft	2	2	2	2
Soil Classification at Sample Elevation	Silt	Silt	Clay	Clay
Intensity Range counts	0-200	0-200	200-210	200-300
Peak Wavelength, nm	410	410	410	410
<p>TRPH = Total Recoverable Petroleum Hydrocarbons. PAH = Polynuclear Aromatic Hydrocarbons. TOC = Total Organic Carbon. OG = Oil and Grease. ppm = parts per million. Lab Method = USEPA SW-846, 1984.</p>				
<i>(Sheet 4 of 6)</i>				

**Verification Sample Information
4400 Area Motor Pool (Continued)**

Sample No.	31395	31394	31397	31398
Type	Soil	Soil	Soil	Soil
Lab Method	8270	8270	8270	8270
TRPH, ppm				
Other, ppm	PAH-Table 7	PAH-Table 7	PAH-Table 7	PAH-Table 7
Easting, ft	2017733	2017733	2017552	2017552
Northing, ft	428229	428229	428081	428081
Elevation Range ft MSL	122.7-123.2	122-122.5	133.3-133.8	121.3-121.8
Sample Fluoresced?	YES	YES	NO	YES
Maximum Intensity, counts	174	132	0	170
Peak Wavelength, nm	409	444	596	429
Nearest Probe	1130-01	1130-01	1124-01	1124-01
Easting, ft	2017731.6	2017731.6	2017550.1	2017550.1
Northing, ft	428228.2	428228.2	428080.6	428080.6
Offset from Sample, ft	2	2	2	2
Soil Classification at Sample Elevation	Clay	Clay	Sand	Sand
Intensity Range counts	200-210	200-300	0-100	0-400
Peak Wavelength, nm	410	410	550	440

TRPH = Total Recoverable Petroleum Hydrocarbons.
 PAH = Polynuclear Aromatic Hydrocarbons.
 TOC = Total Organic Carbon.
 OG = Oil and Grease.
 ppm = parts per million.
 Lab Method = USEPA SW-846, 1984

(Sheet 5 of 6)

**Verification Sample Information
4400 Area Motor Pool (Concluded)**

Sample No.	31397	31398	29525	29526
Type	Soil	Soil	Soil	Soil
Lab Method	418.1/413.2	418.1/413.2	8270	8270
TRPH, ppm	7.0	2700		
Other, ppm	27(OG)	3500(OG)	PAH-Table 7	PAH-Table 7
Easting, ft	2017552	2017552	2017671	2017671
Northing, ft	428081	428081	428421	428421
Elevation Range ft MSL	133.3-133.8	121.3-121.8	116-117	120-121
Sample Fluoresced?	NO	YES	YES	YES
Maximum Intensity, counts	0	170	12	27
Peak Wavelength, nm	596	429	464	478
Nearest probe	1124-01	1124-01	1130-05	1130-05
Easting, ft	2017550.1	2017550.1	2017670	2017670
Northing, ft	428080.6	428080.6	428420.4	428420.4
Offset from Sample, ft	2	2	2	2
Soil Classification at Sample Elevation	Sand	Sand	Sand	Clay
Intensity Range counts	0-100	0-400	0-100	0
Peak Wavelength, nm	550	440	490	N/A

TRPH = Total Recoverable Petroleum Hydrocarbons.
 PAH = Polynuclear Aromatic Hydrocarbons.
 TOC = Total Organic Carbon.
 OG = Oil and Grease.
 ppm = parts per million.
 Lab Method = USEPA SW-846, 1984.

(Sheet 6 of 6)

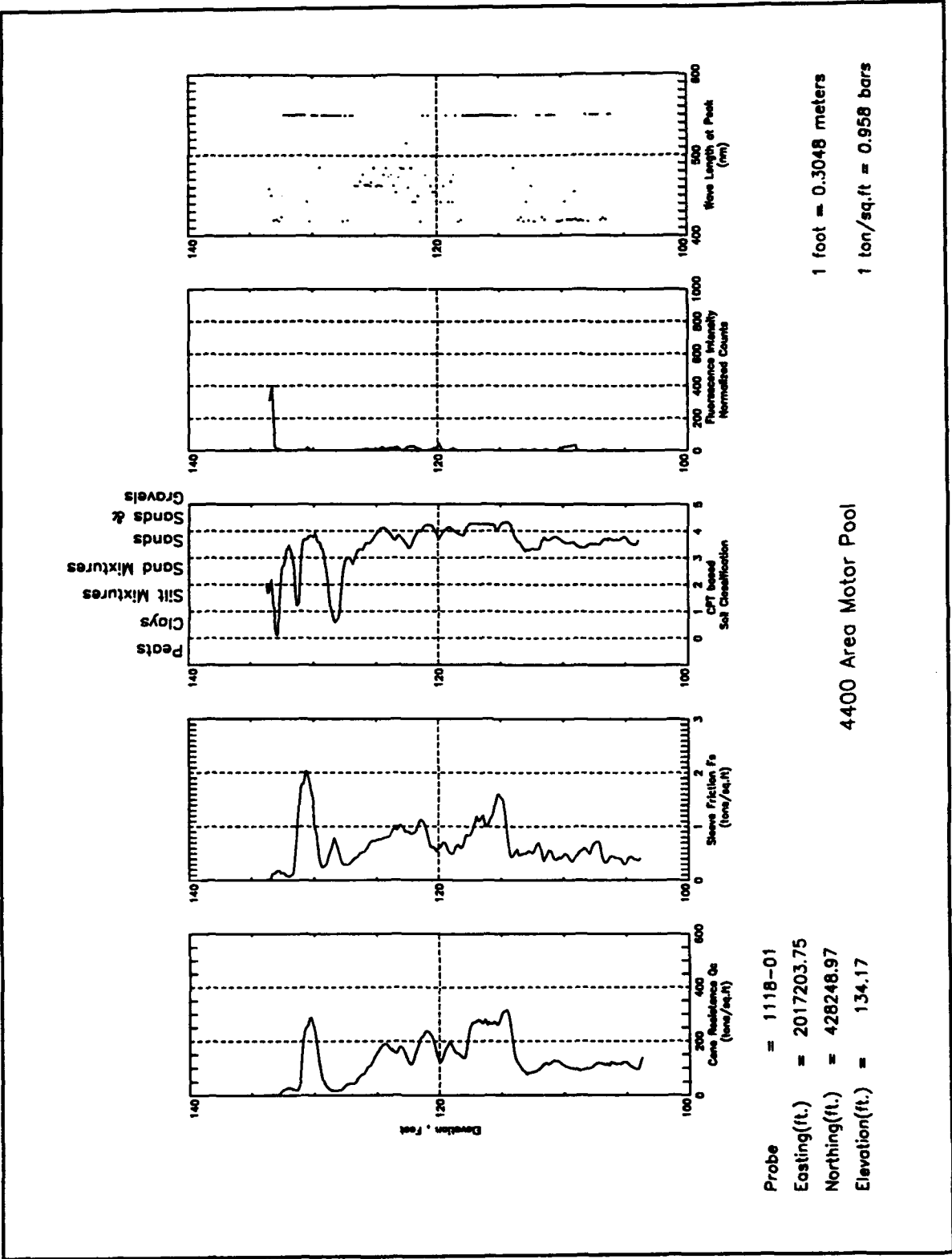

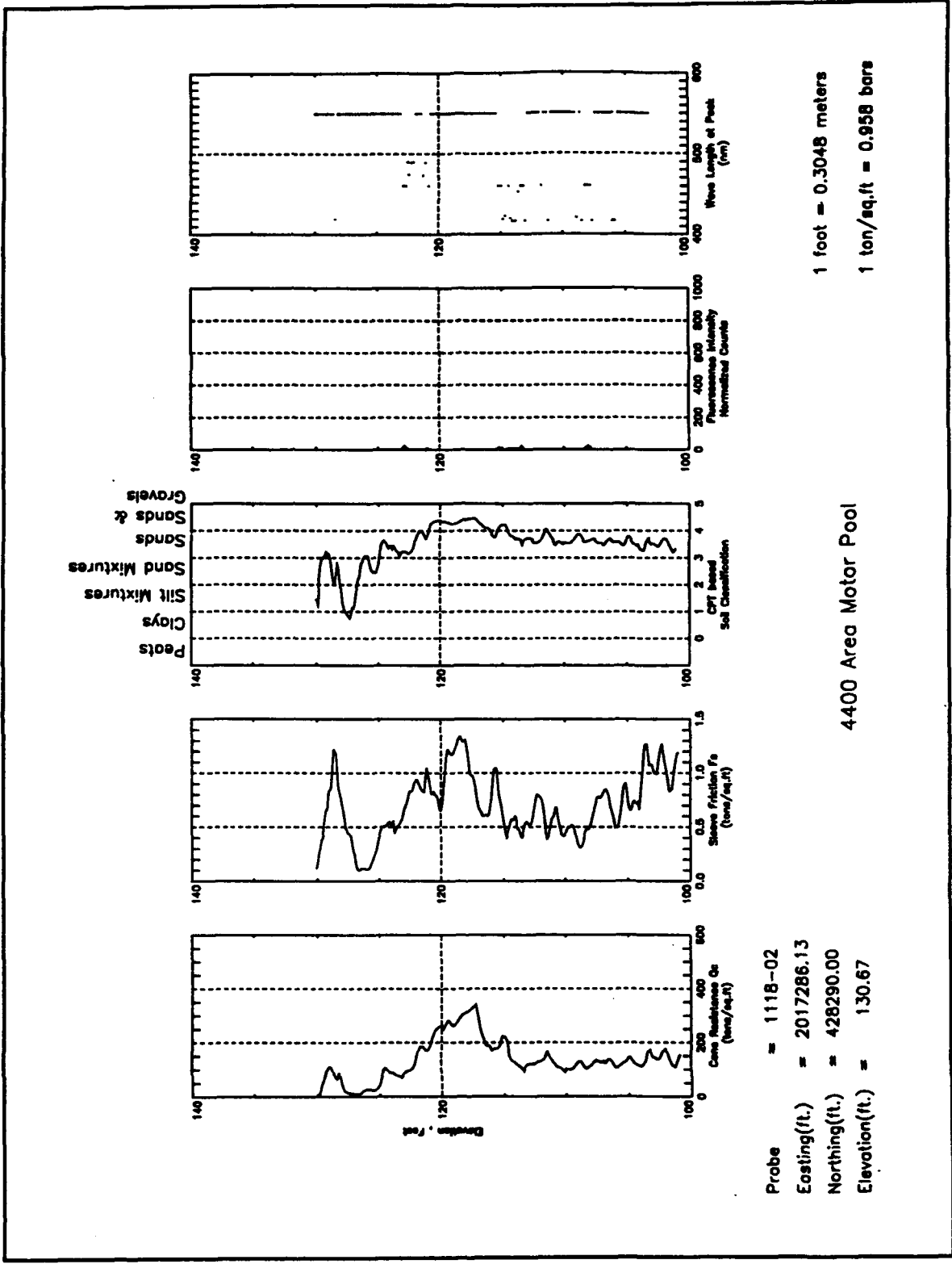

Probe = 1118-02
 Easting(ft.) = 2017286.13
 Northing(ft.) = 428290.00
 Elevation(ft.) = 130.67

1 foot = 0.3048 meters
 1 ton/sq.ft = 0.958 bars

4400 Area Motor Pool

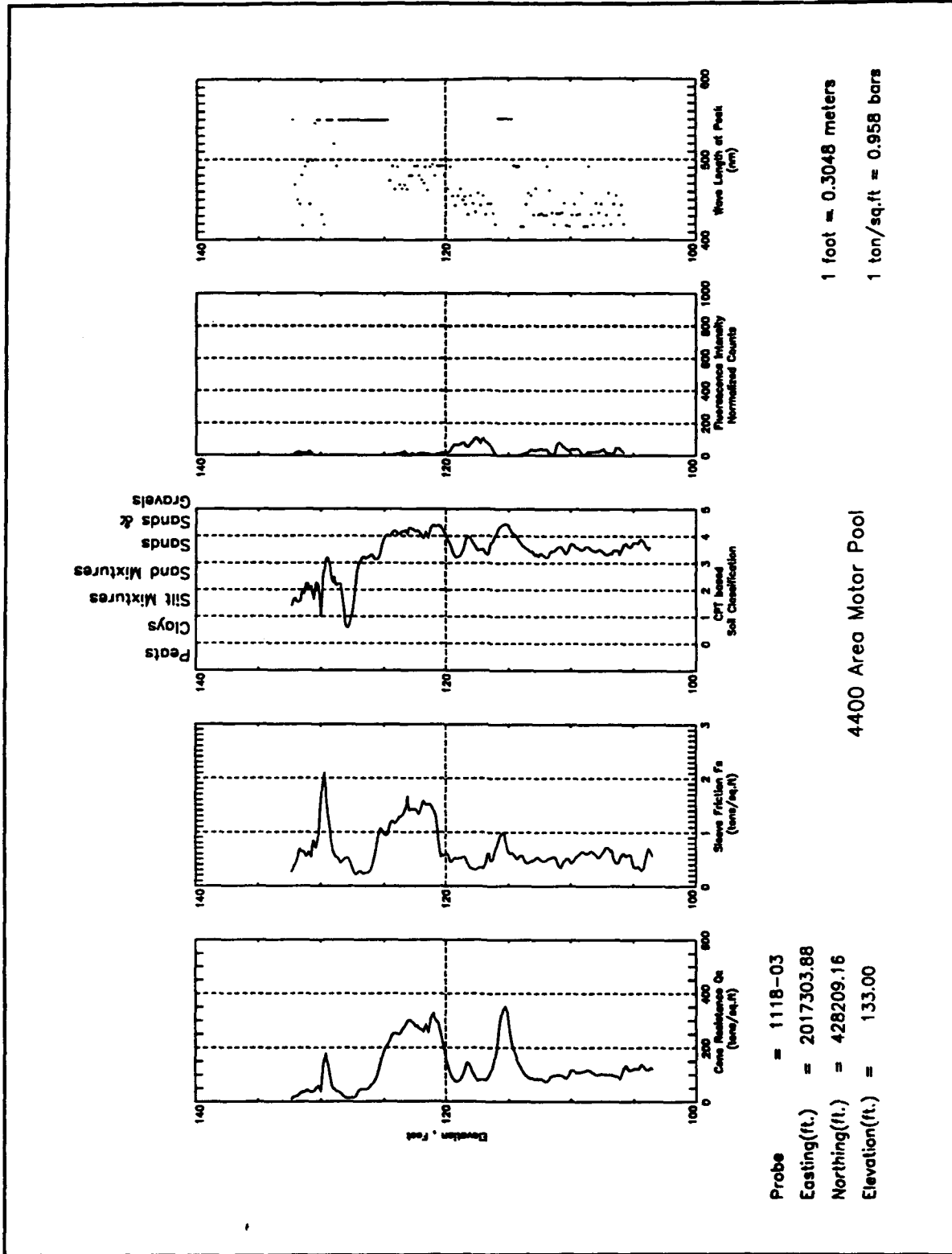

Probe = 1118-03
 Easting(ft.) = 2017303.88
 Northing(ft.) = 428209.16
 Elevation(ft.) = 133.00

1 foot = 0.3048 meters
 1 ton/sq.ft = 0.958 bars
 4400 Area Motor Pool

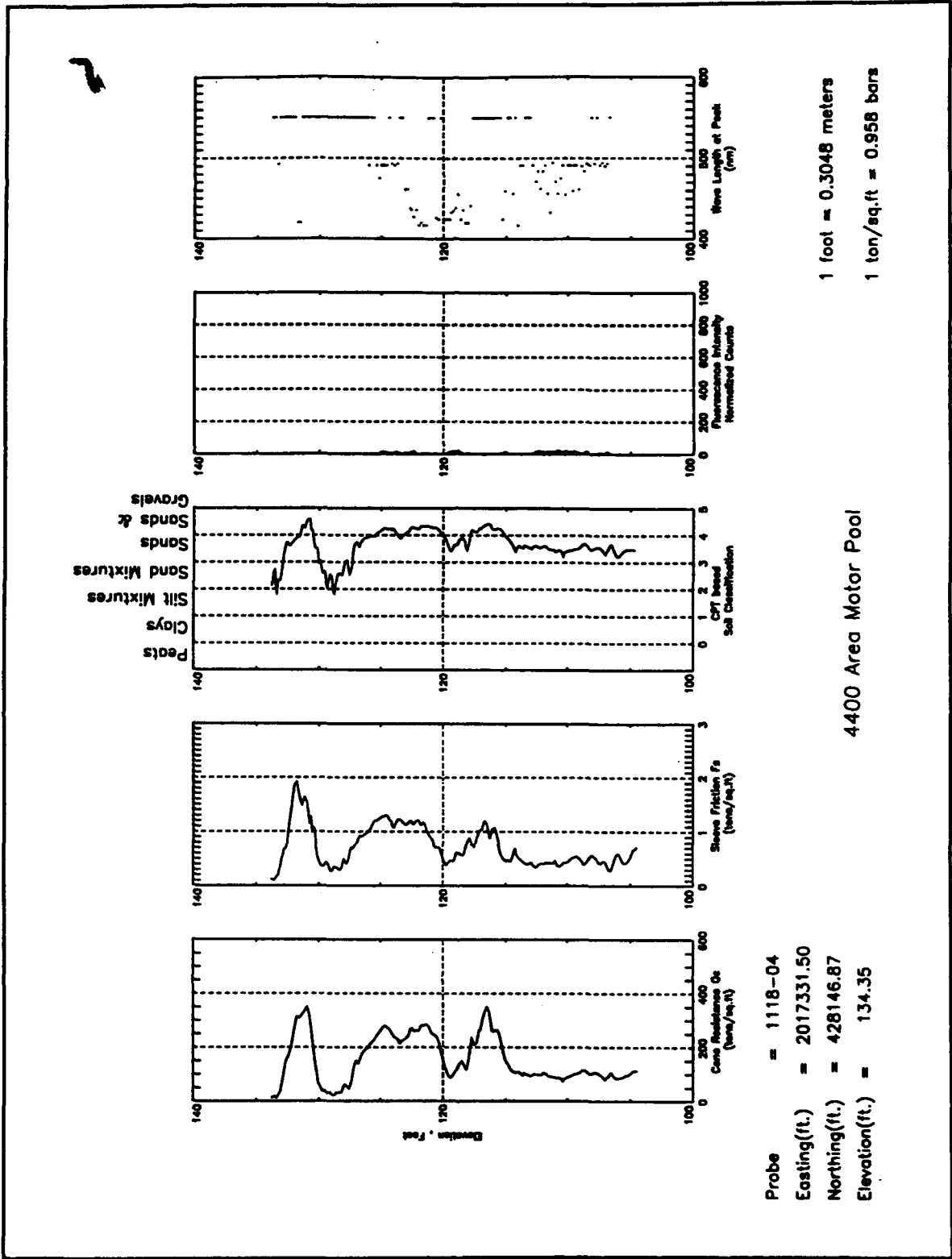

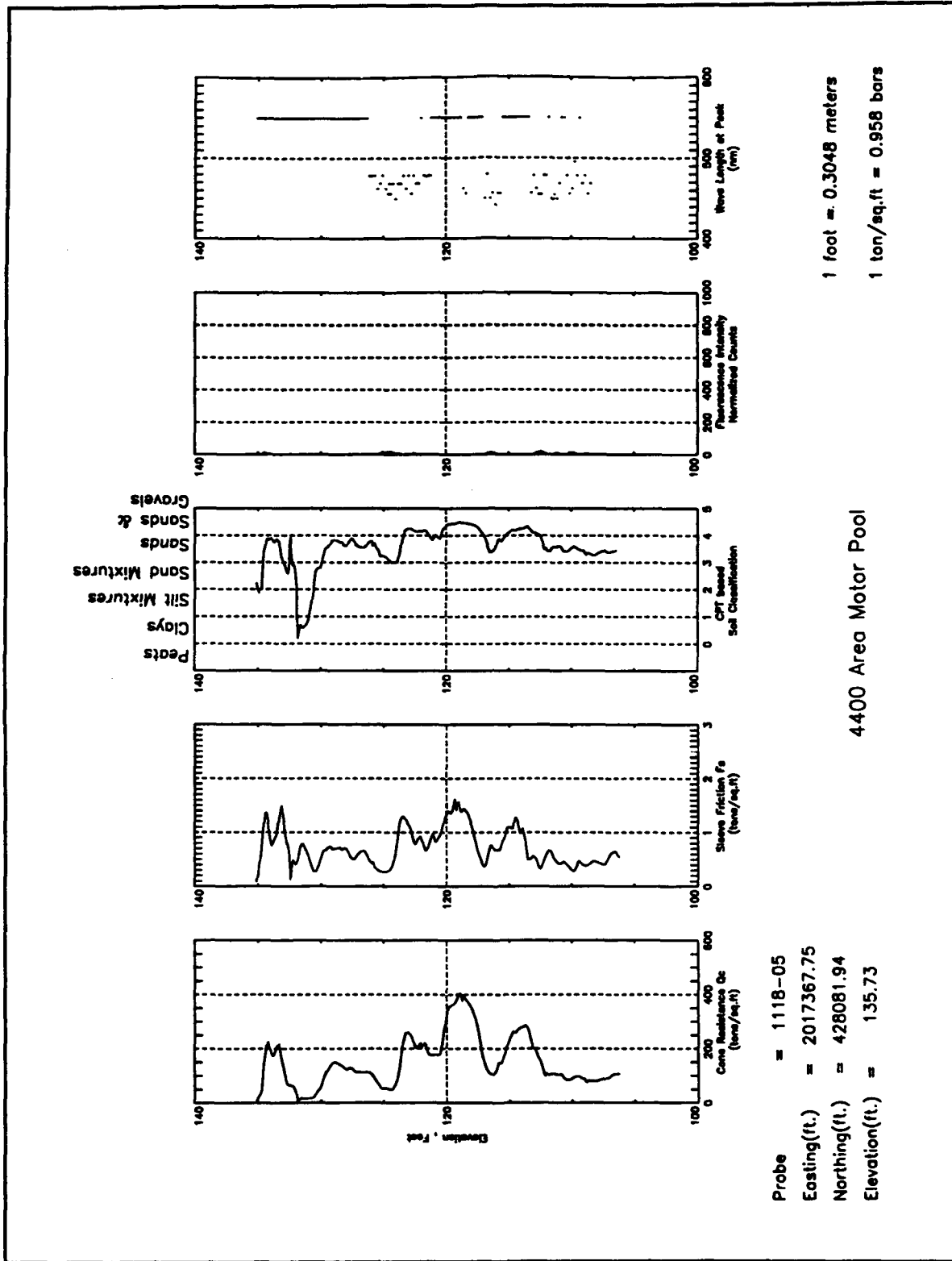

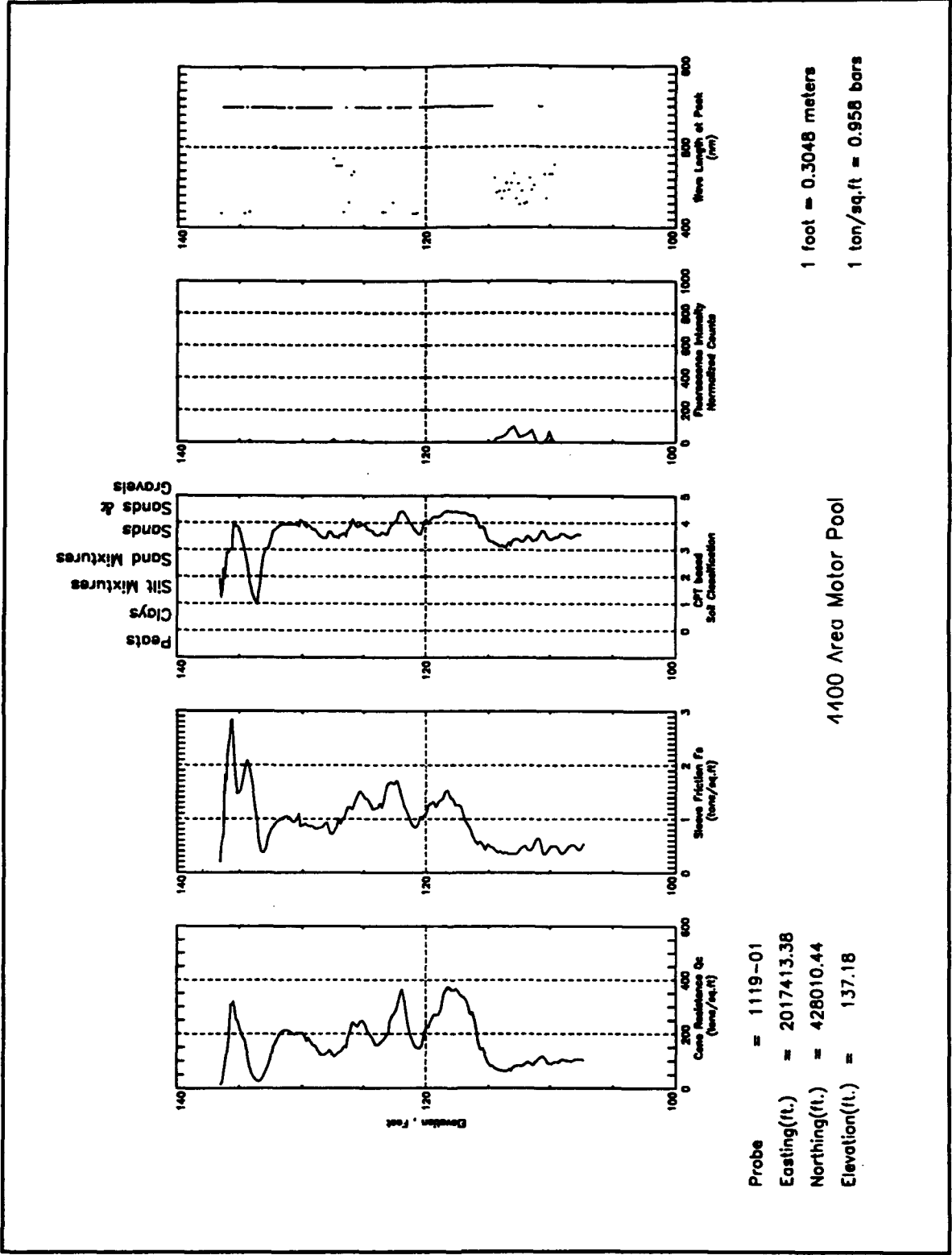

Probe = 1119-01
 Easting(ft.) = 2017413.38
 Northing(ft.) = 428010.44
 Elevation(ft.) = 137.18

1 foot = 0.3048 meters
 1 ton/sq.ft = 0.958 bars

4100 Area Motor Pool

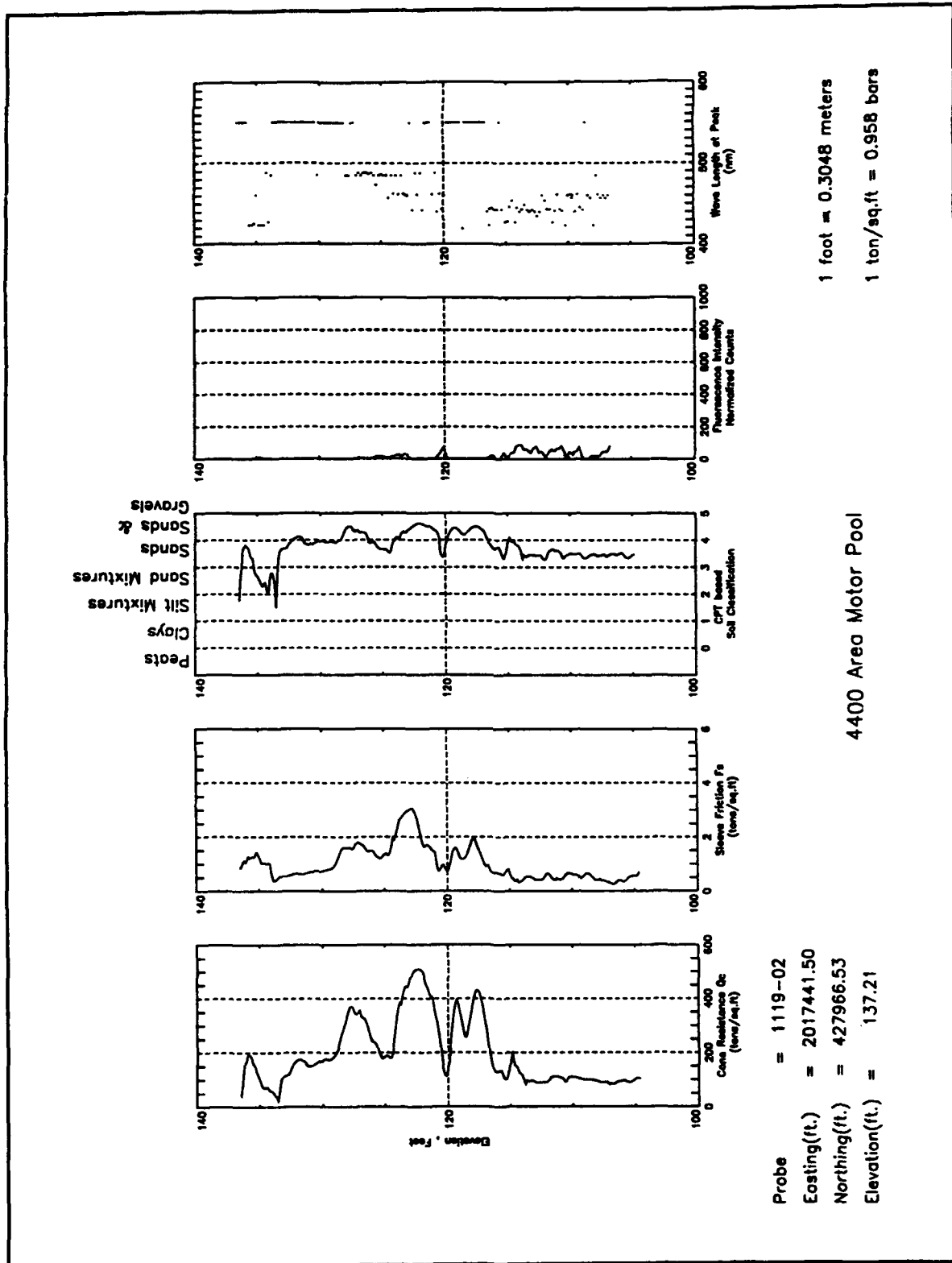

Probe = 1119-02
 Easting(ft.) = 2017441.50
 Northing(ft.) = 427966.53
 Elevation(ft.) = 137.21

4400 Area Motor Pool

1 foot = 0.3048 meters
 1 ton/sq.ft = 0.958 bars

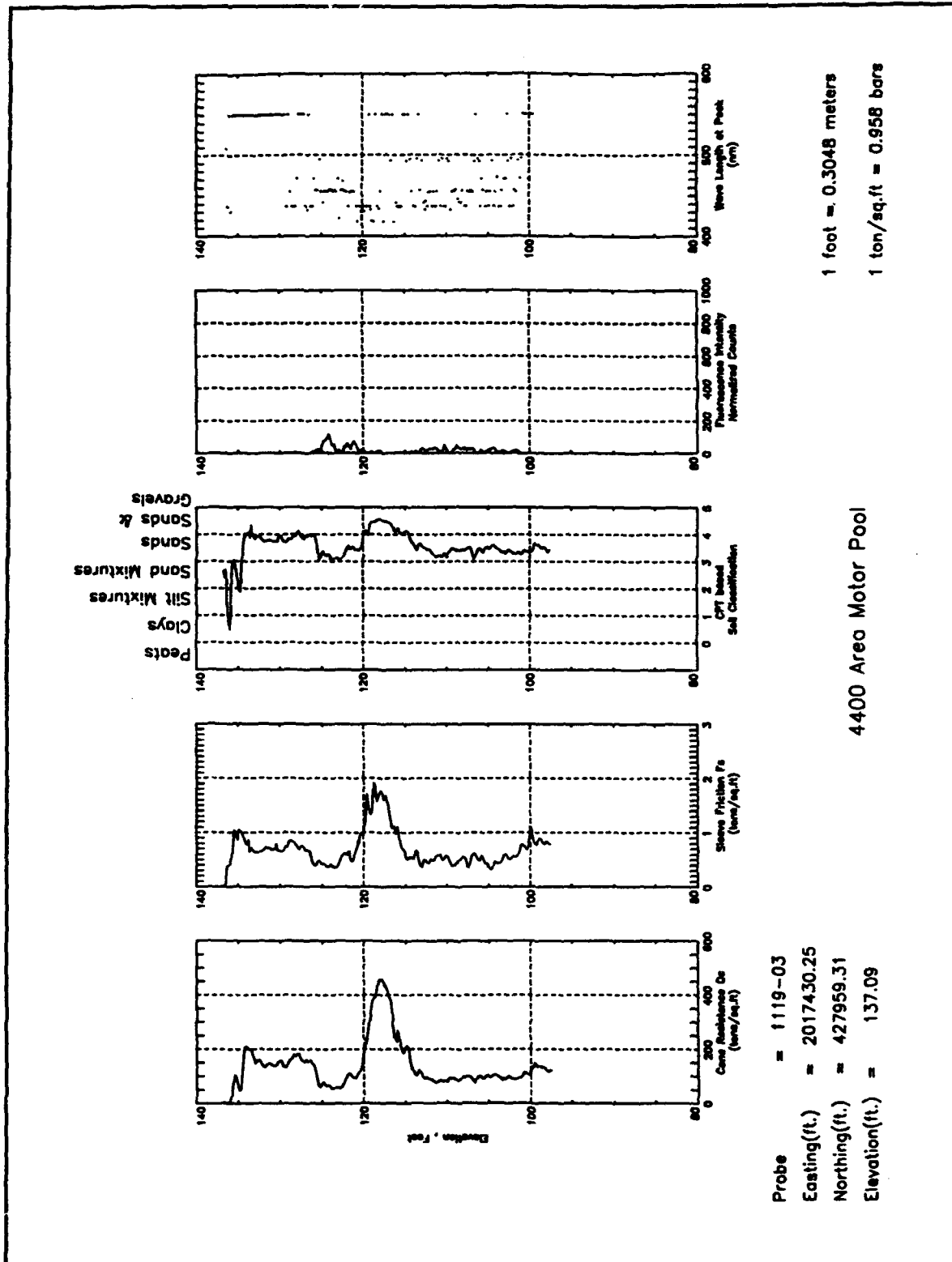

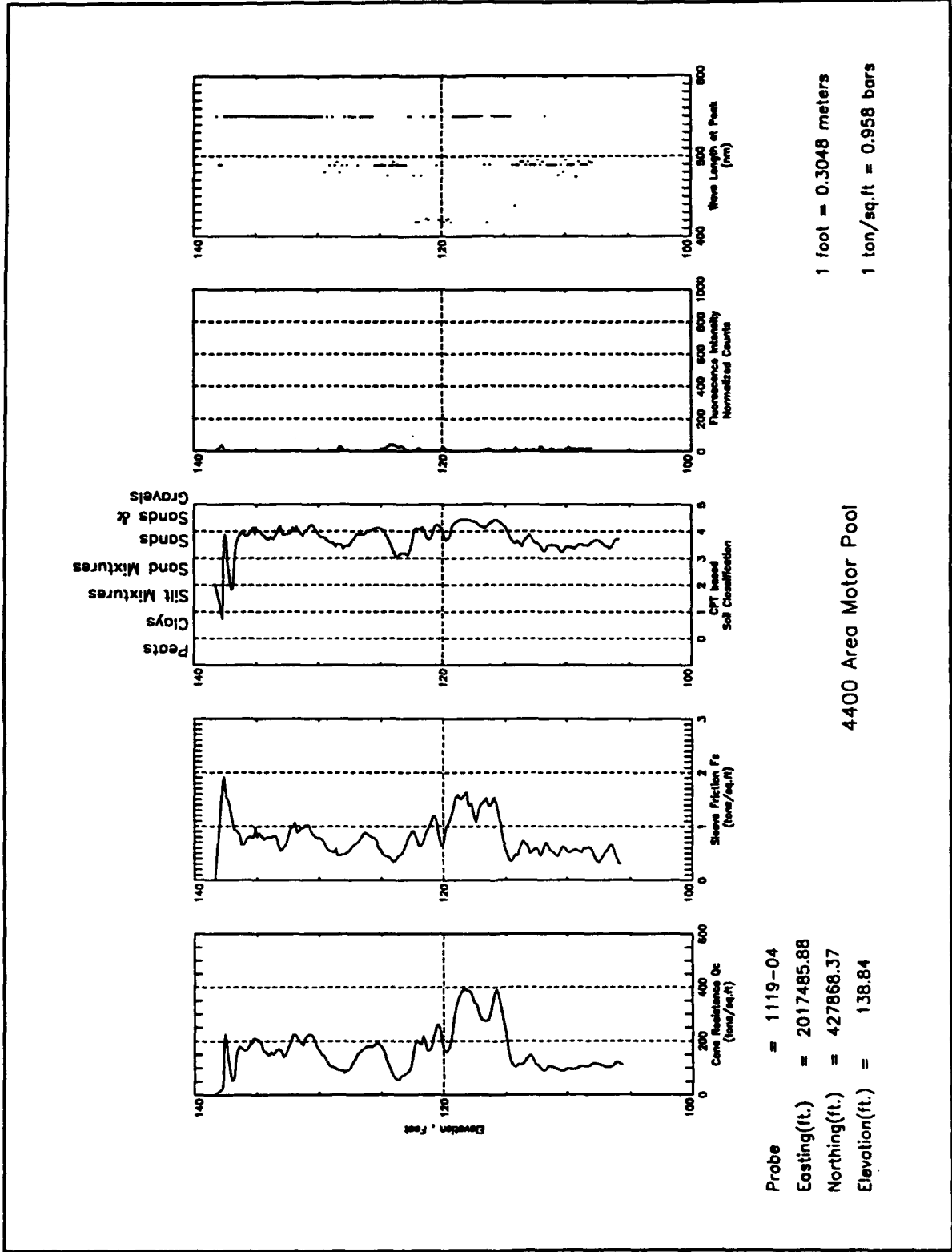

Probe = 1119-04
 Easting(ft.) = 2017485.88
 Northing(ft.) = 427868.37
 Elevation(ft.) = 138.84

4400 Area Motor Pool

1 foot = 0.3048 meters
 1 ton/sq.ft = 0.958 bars

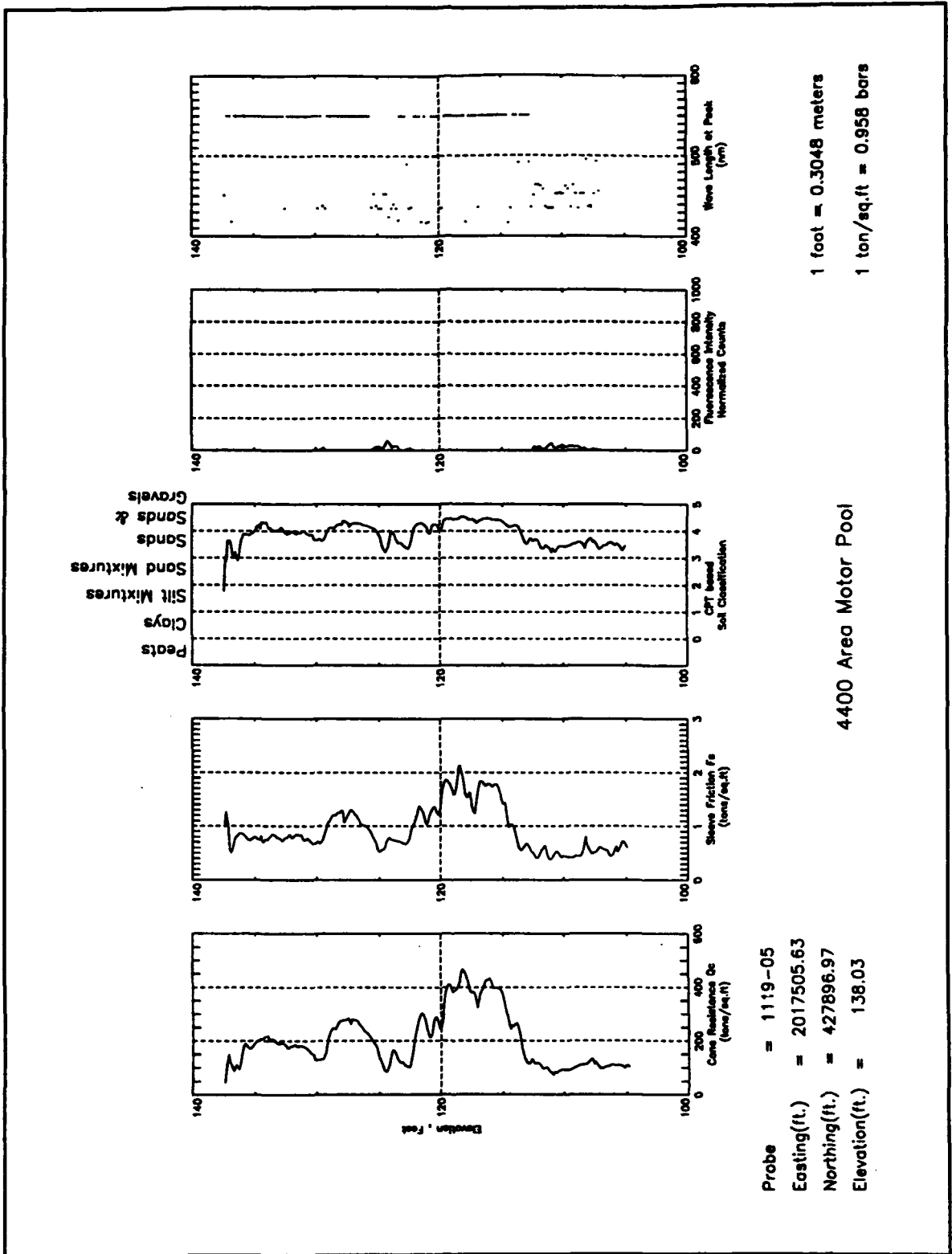

Probe = 1119-05
 Easting(ft.) = 2017505.63
 Northing(ft.) = 427896.97
 Elevation(ft.) = 138.03

1 foot = 0.3048 meters
 1 ton/sq.ft = 0.958 bars

4400 Area Motor Pool

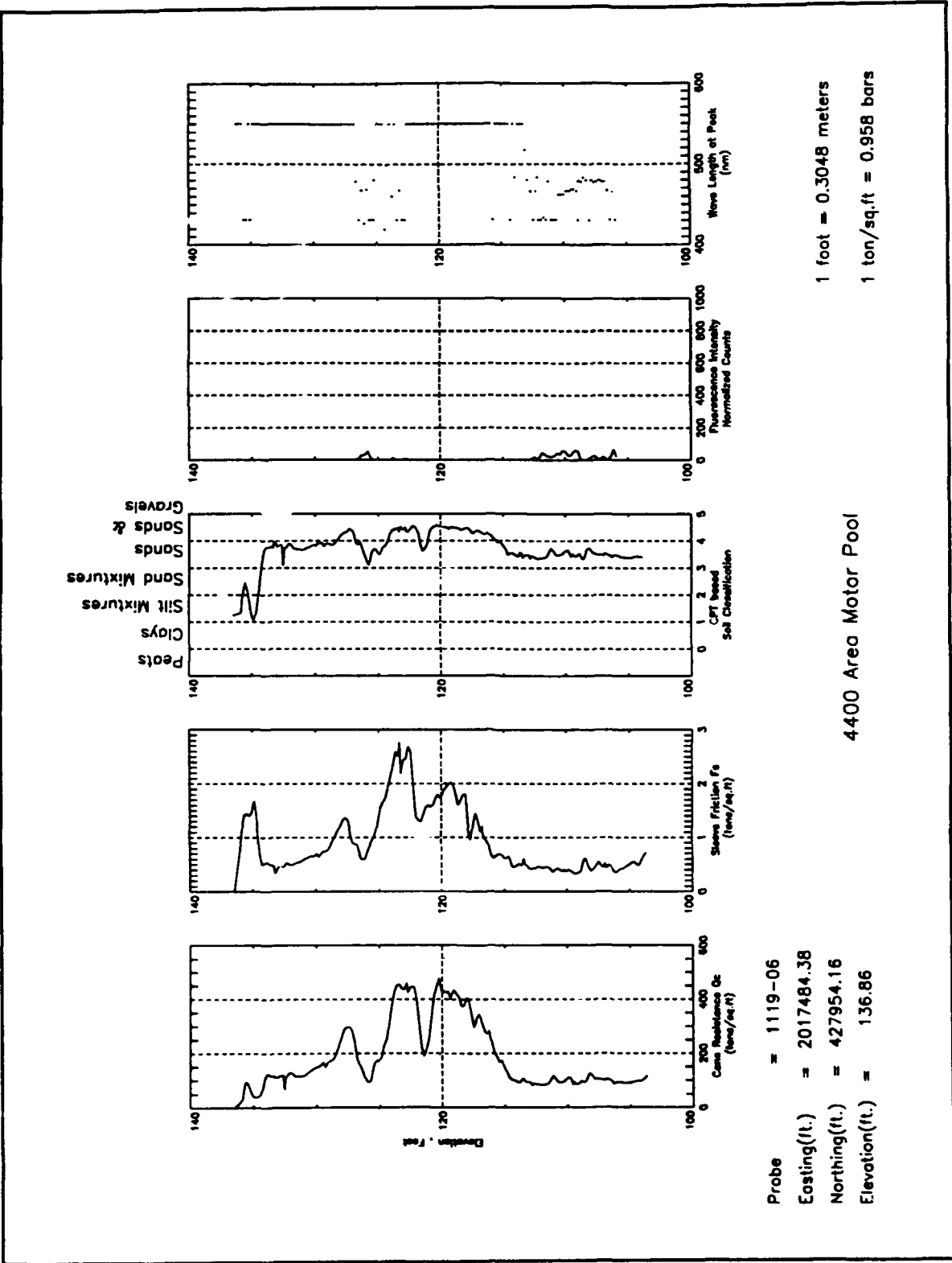

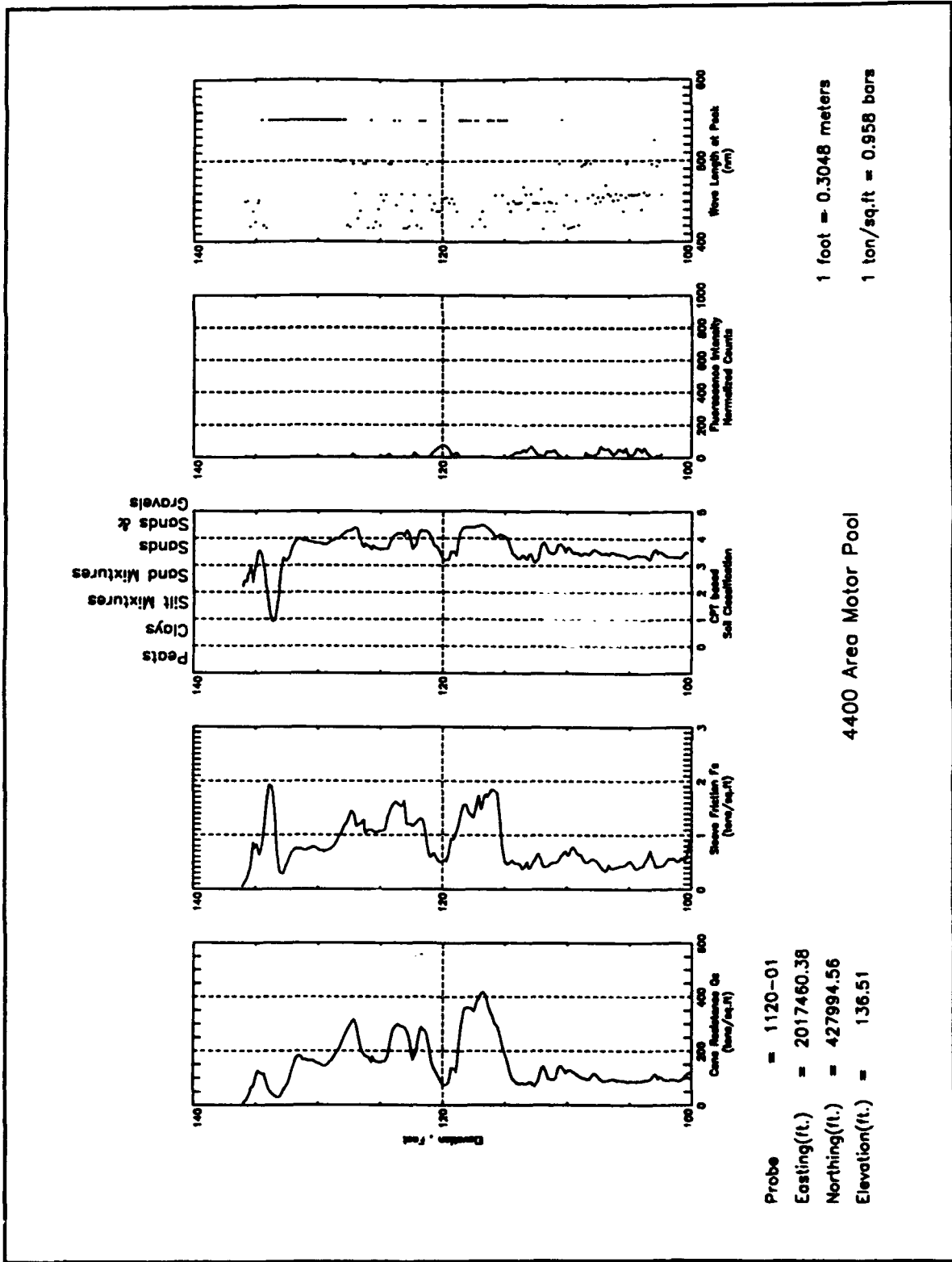

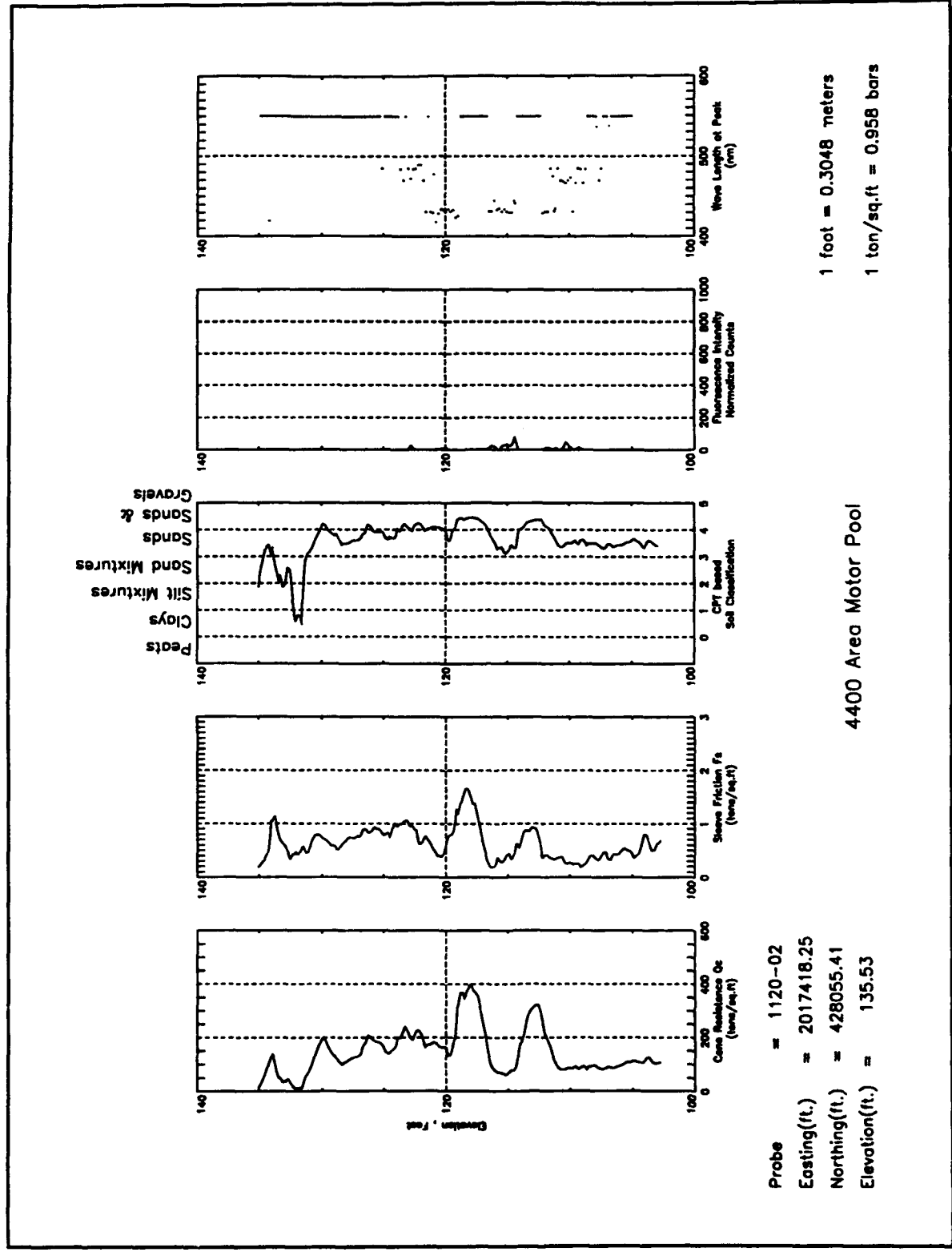

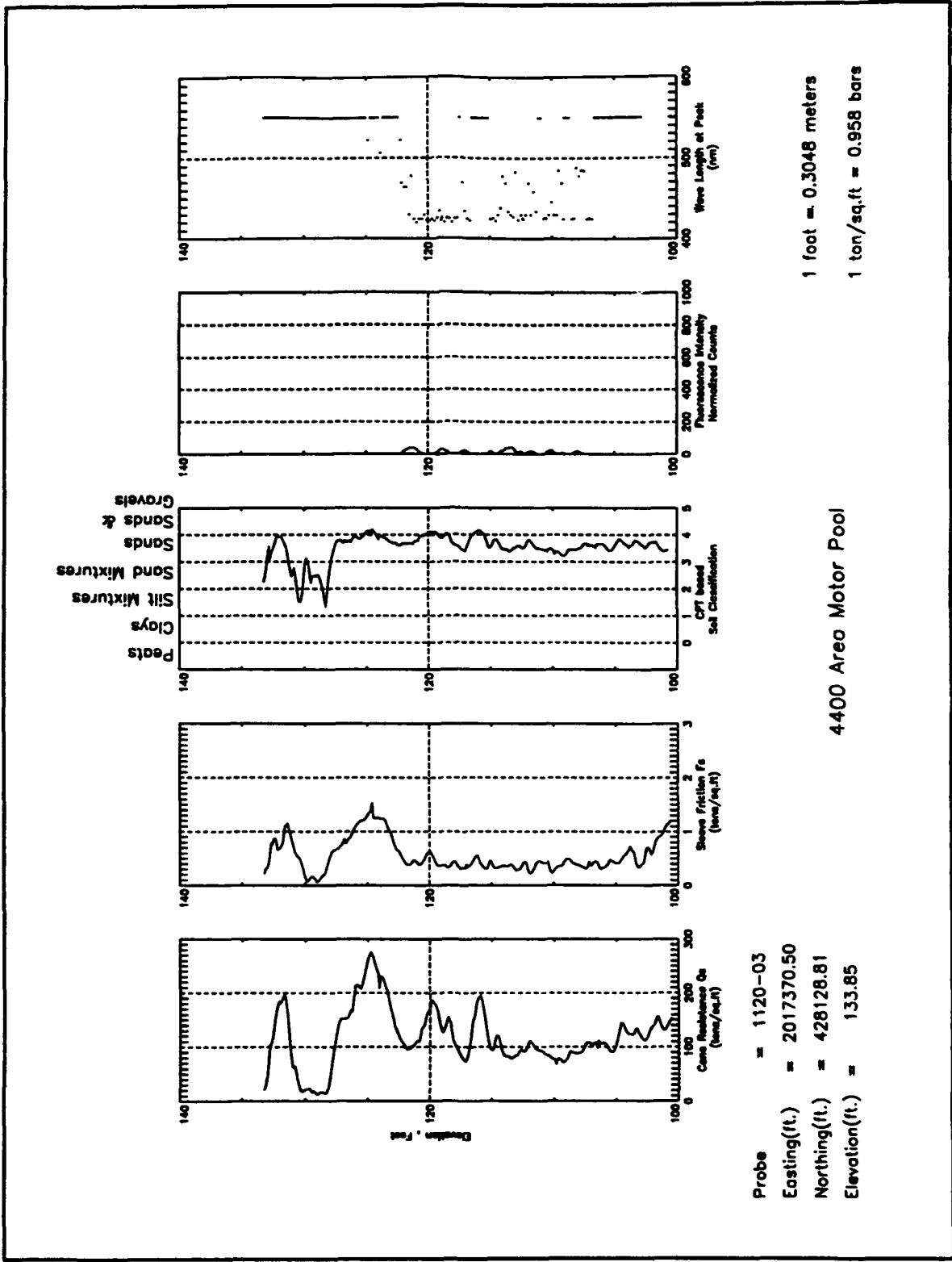

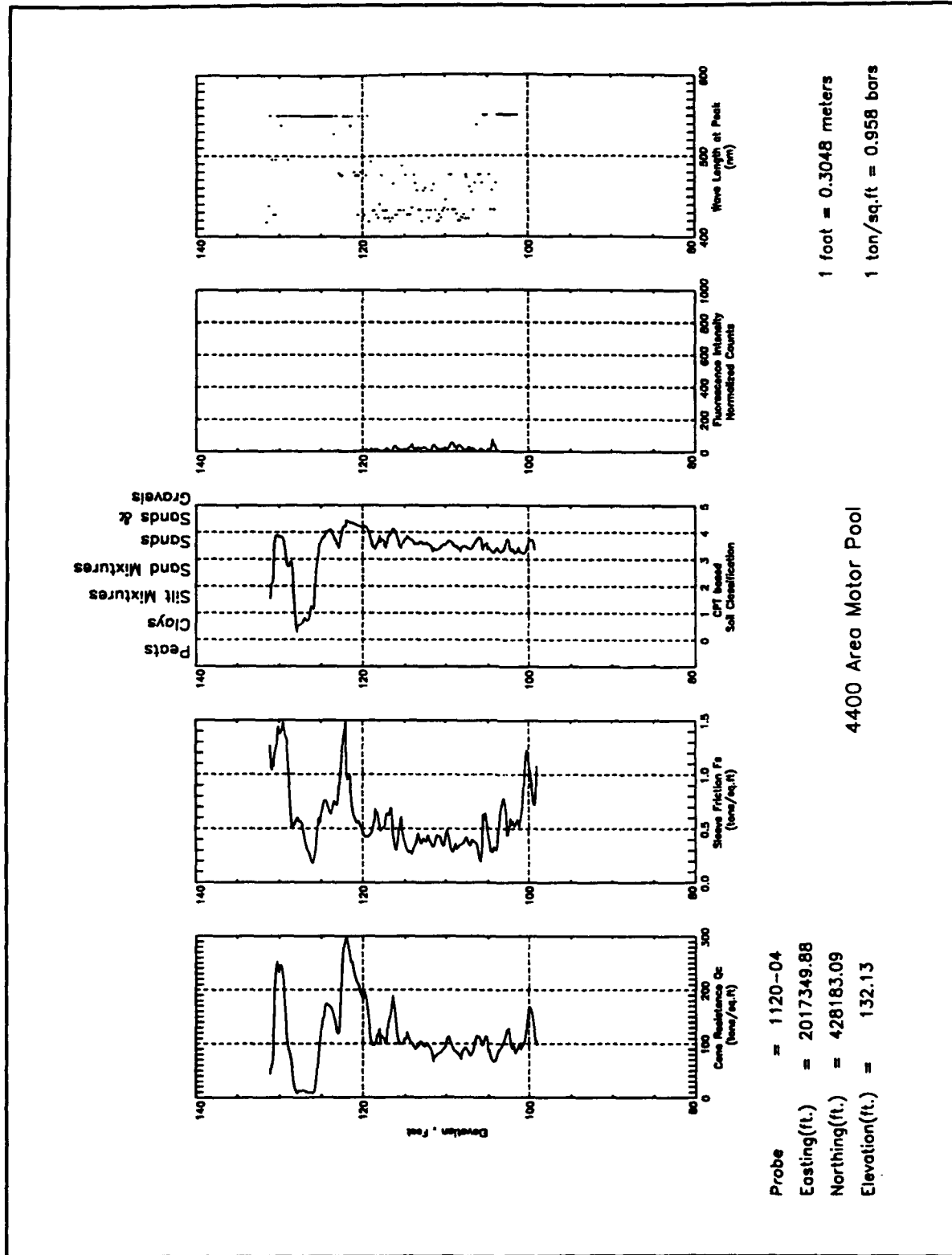

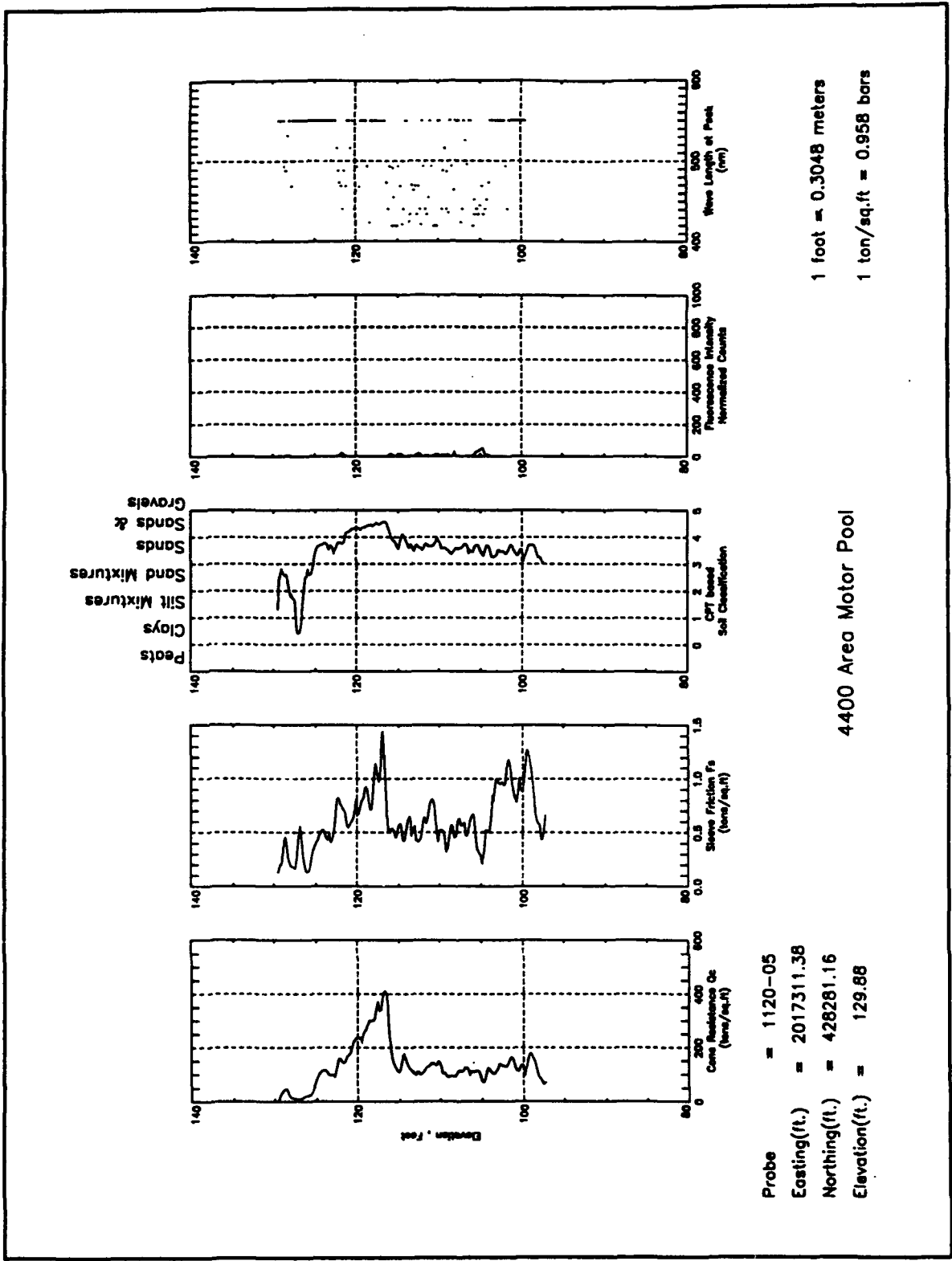

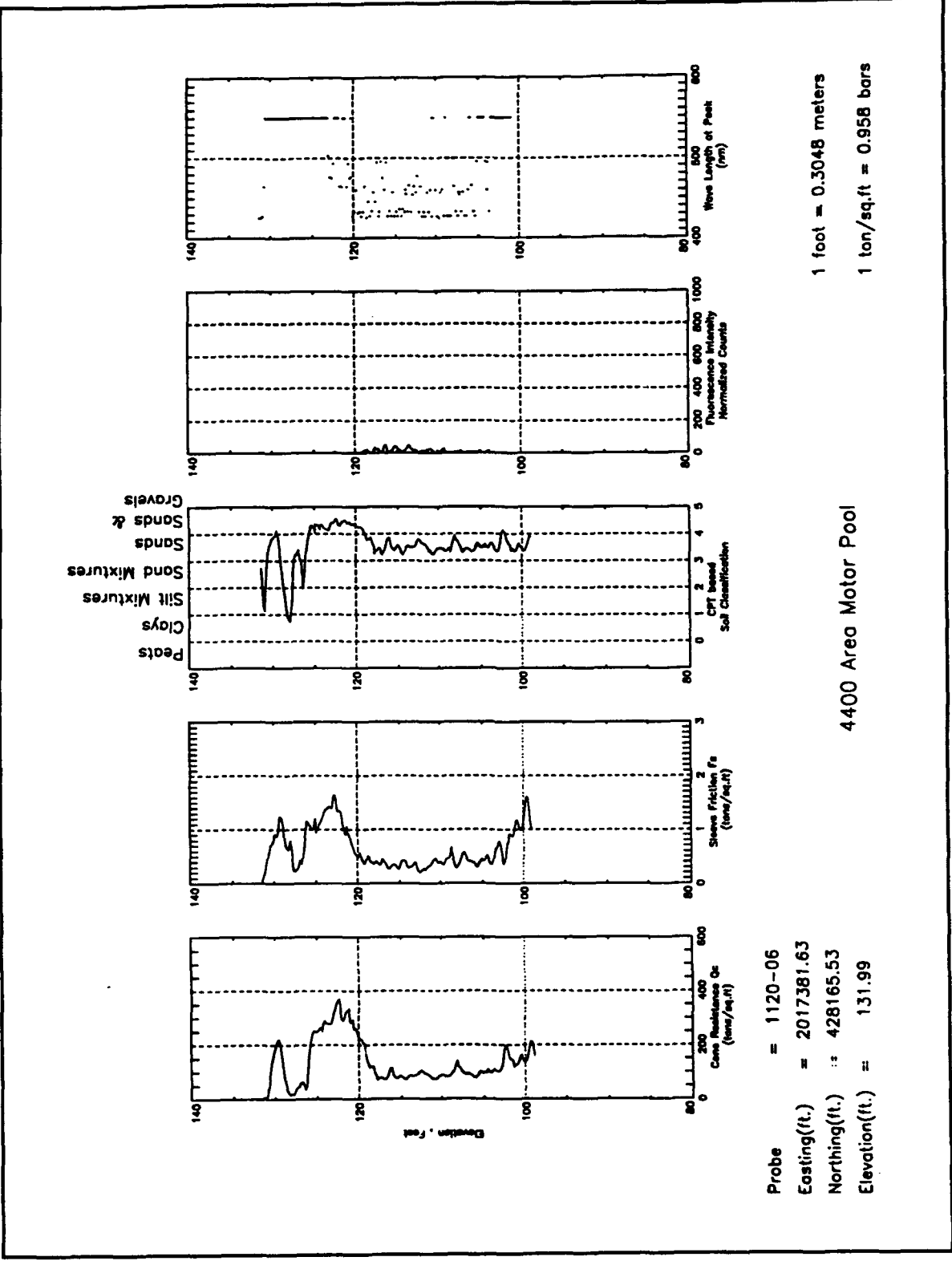

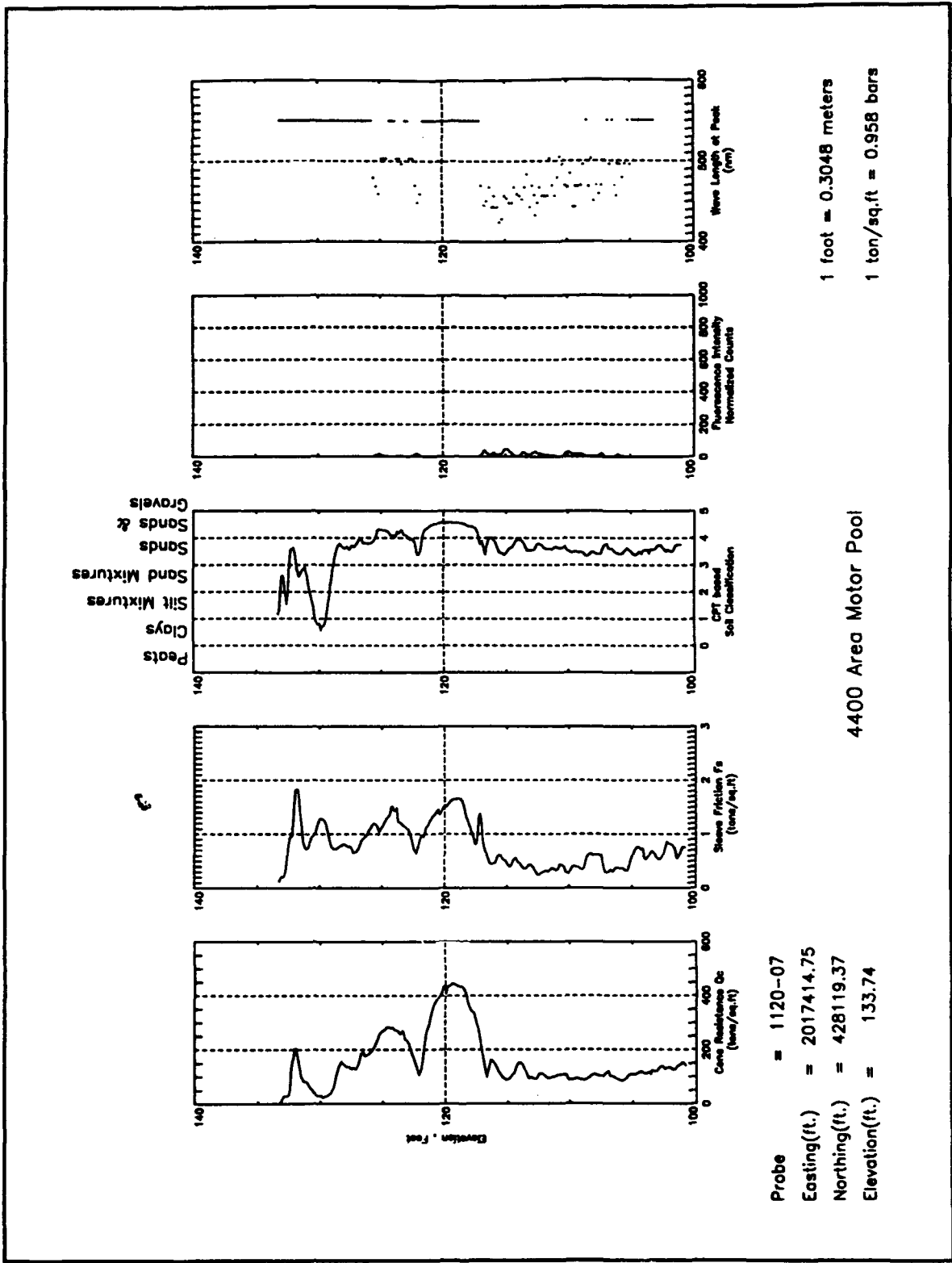

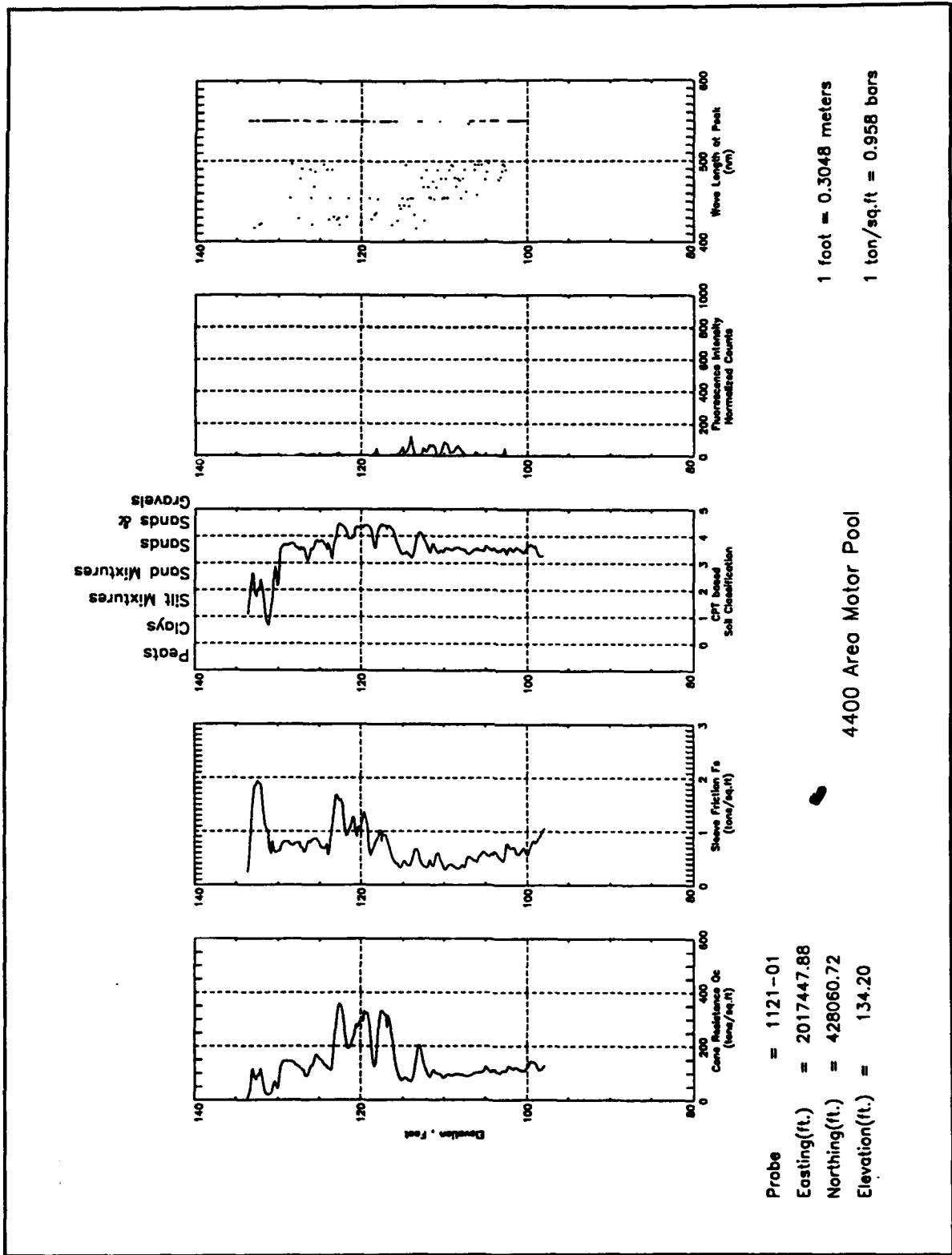

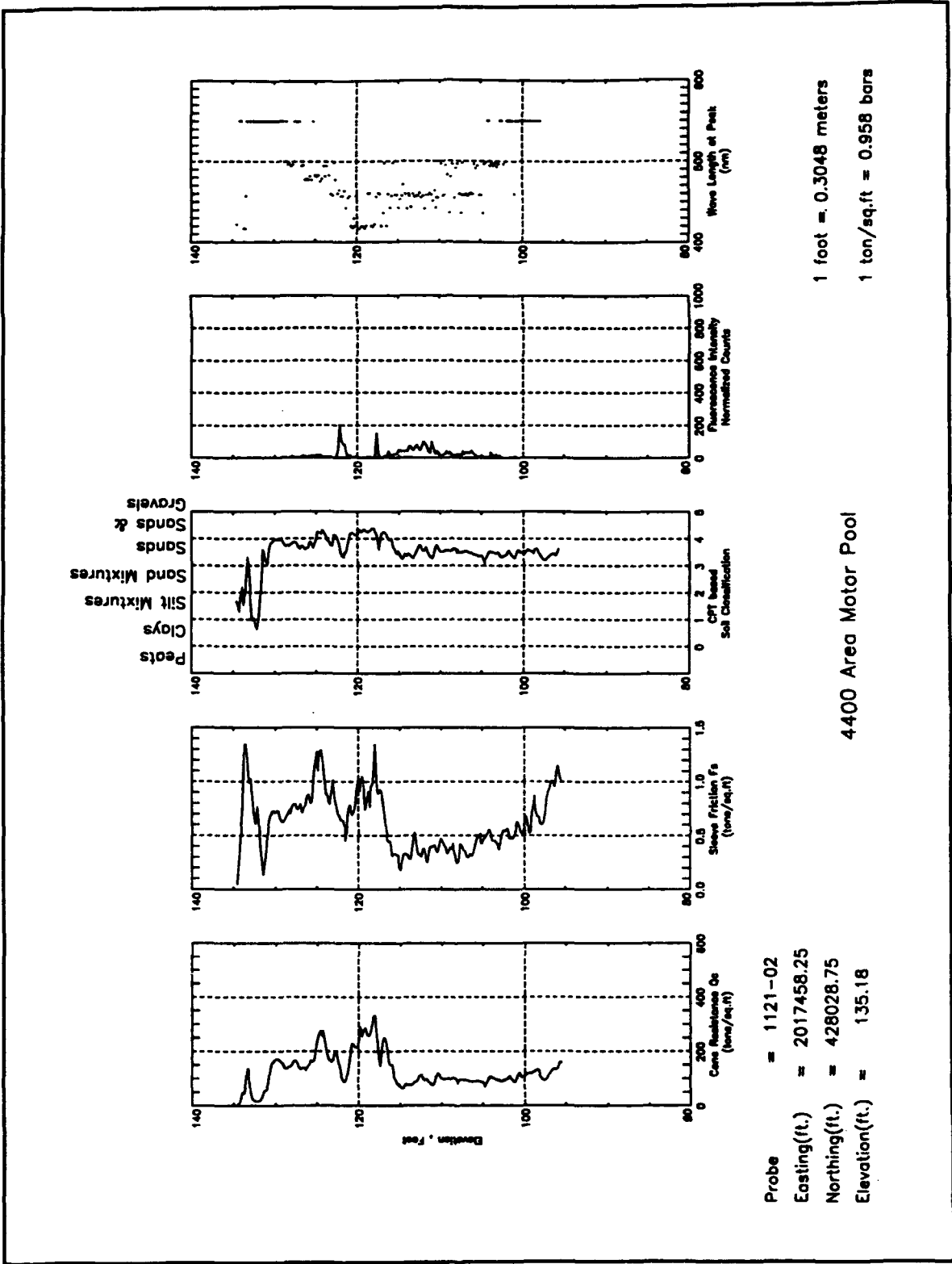

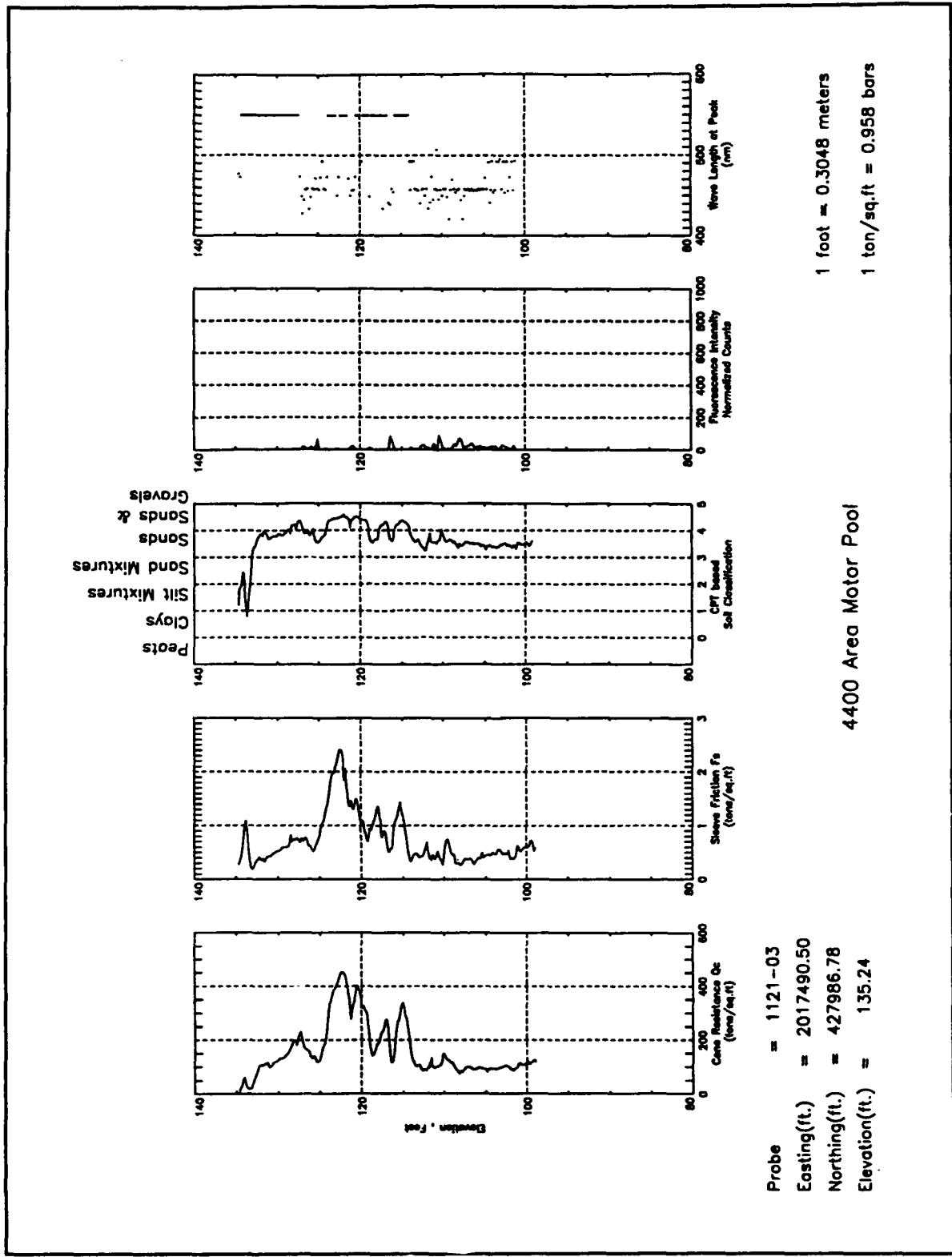

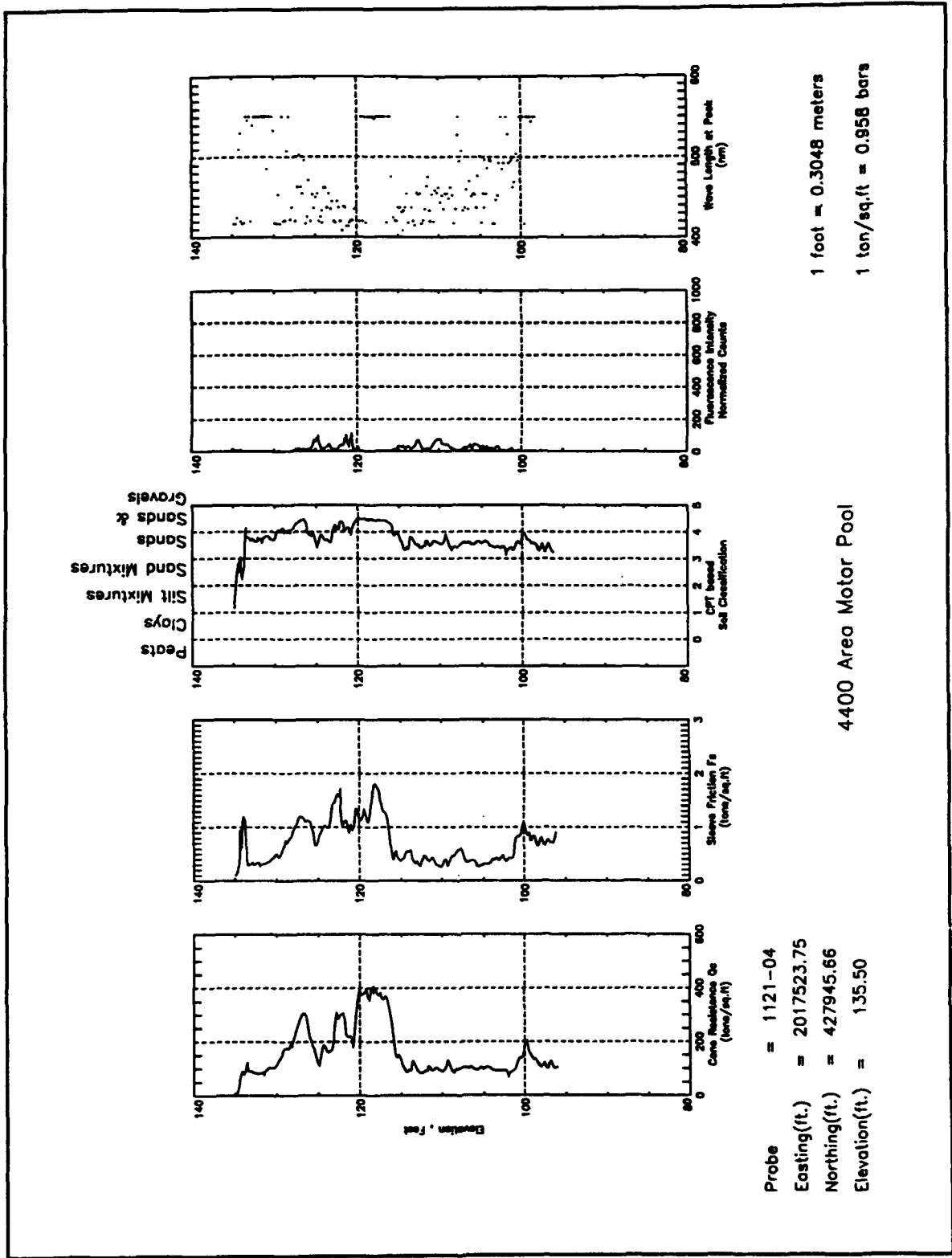

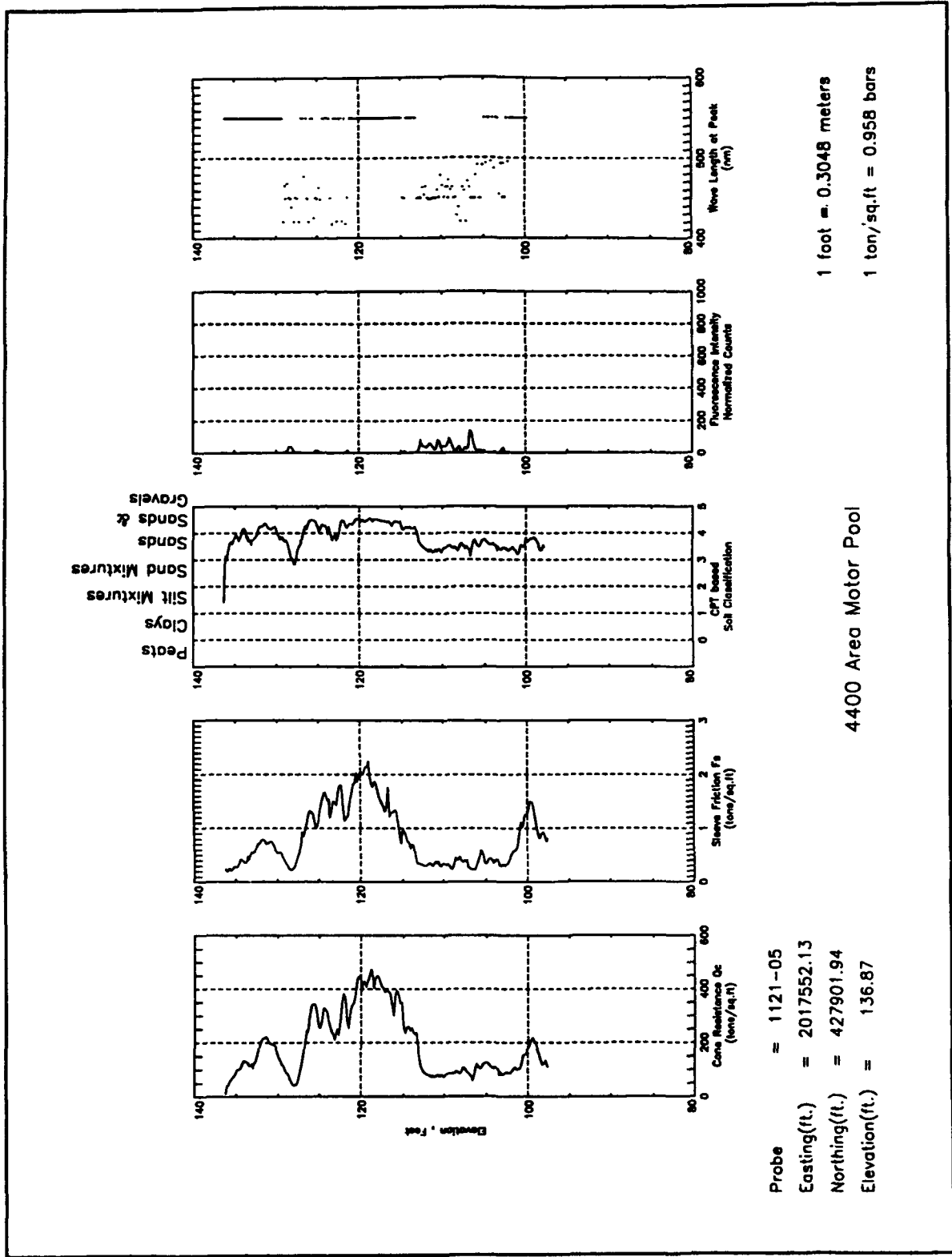

Probe = 1121-05
 Easting(ft.) = 2017552.13
 Northing(ft.) = 427901.94
 Elevation(ft.) = 136.87

4400 Area Motor Pool

1 foot = 0.3048 meters
 1 ton/sq.ft = 0.958 bars

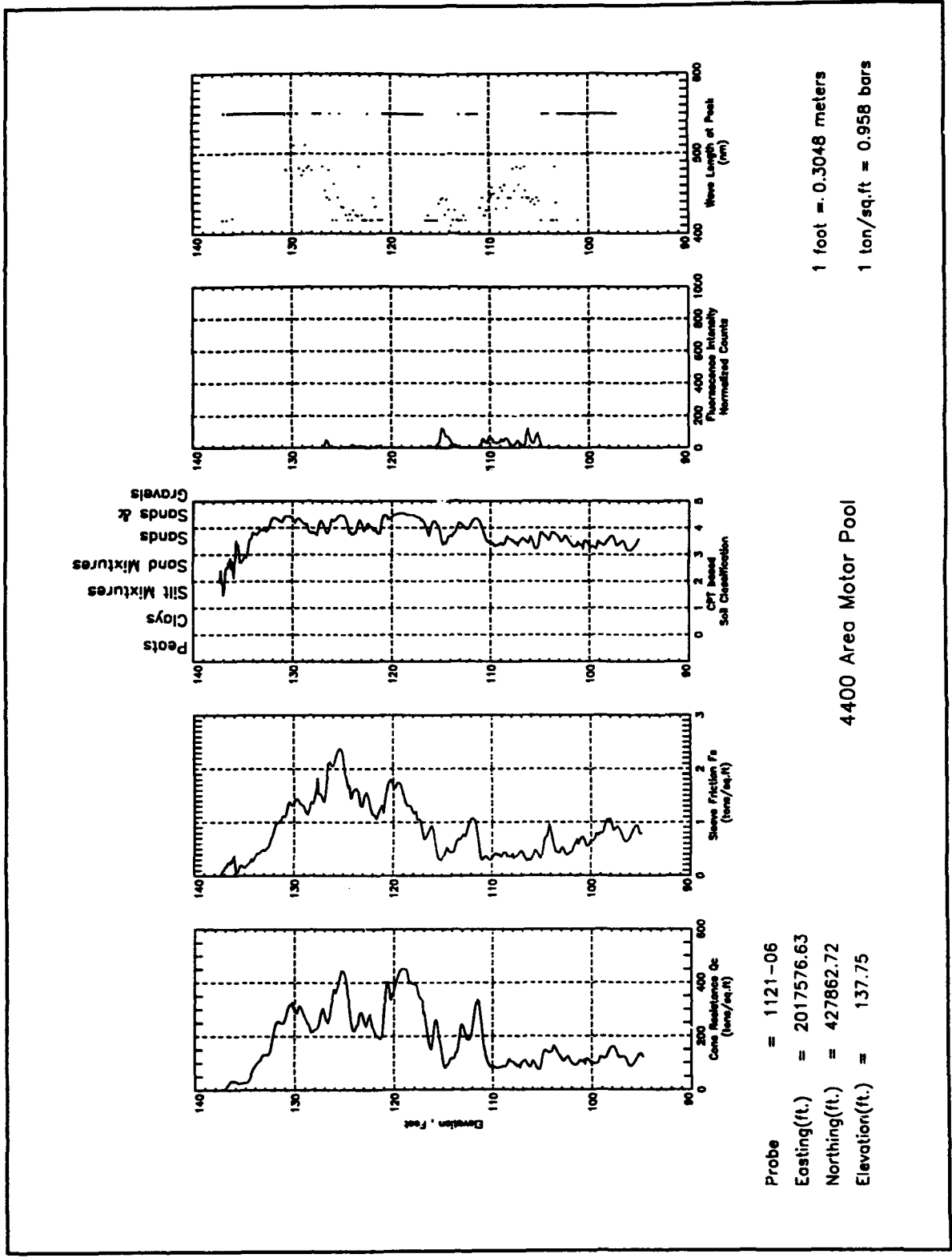

Probe = 1121-06
 Easting(ft.) = 2017576.63
 Northing(ft.) = 427862.72
 Elevation(ft.) = 137.75

1 foot = 0.3048 meters
 1 ton/sq.ft = 0.958 bars

4400 Area Motor Pool

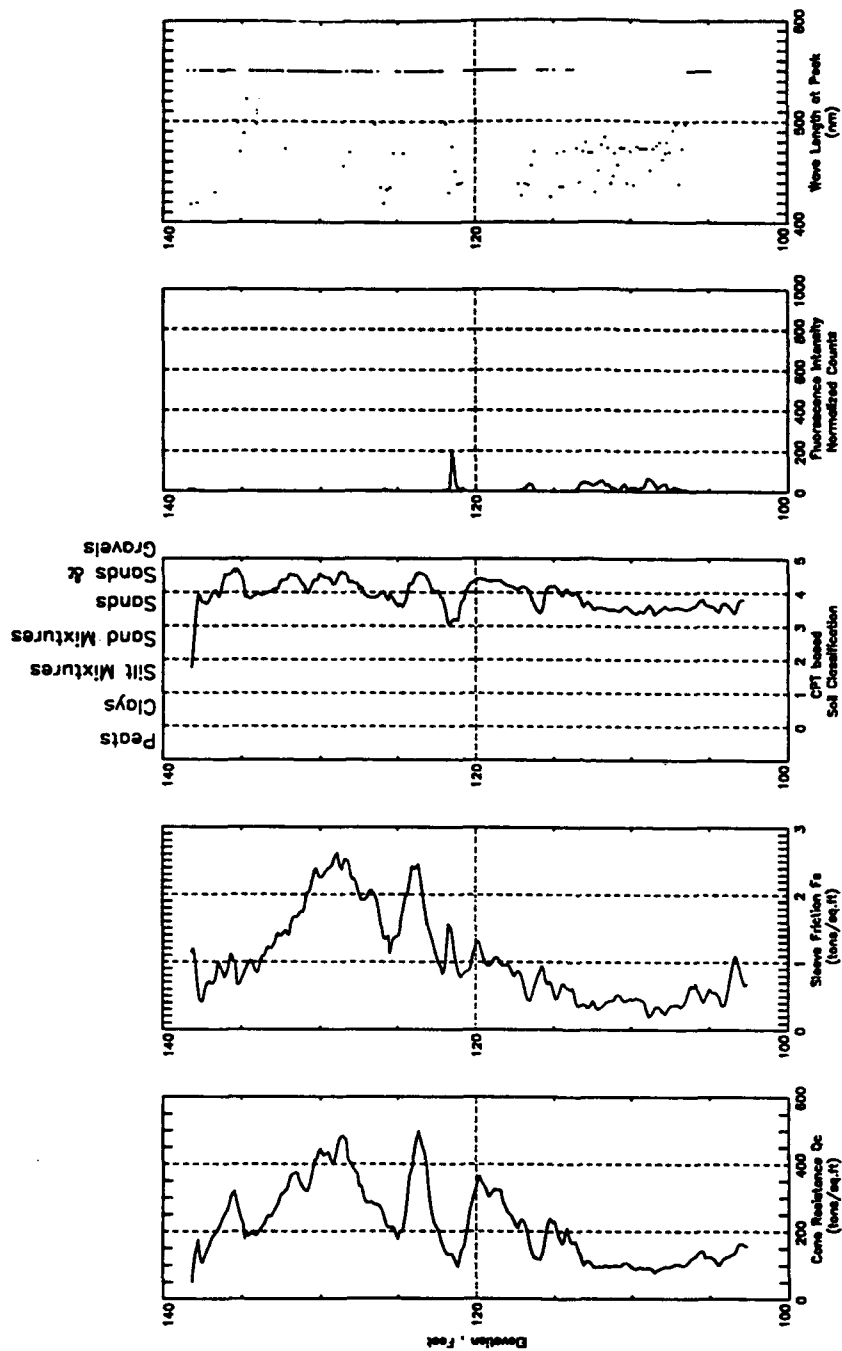

Probe = 1123-01
 Easting(ft.) = 2017598.75
 Northing(ft.) = 427812.06
 Elevation(ft.) = 139.10

1 foot = 0.3048 meters
 1 ton/sq.ft = 0.958 bars

4400 Area Motor Pool

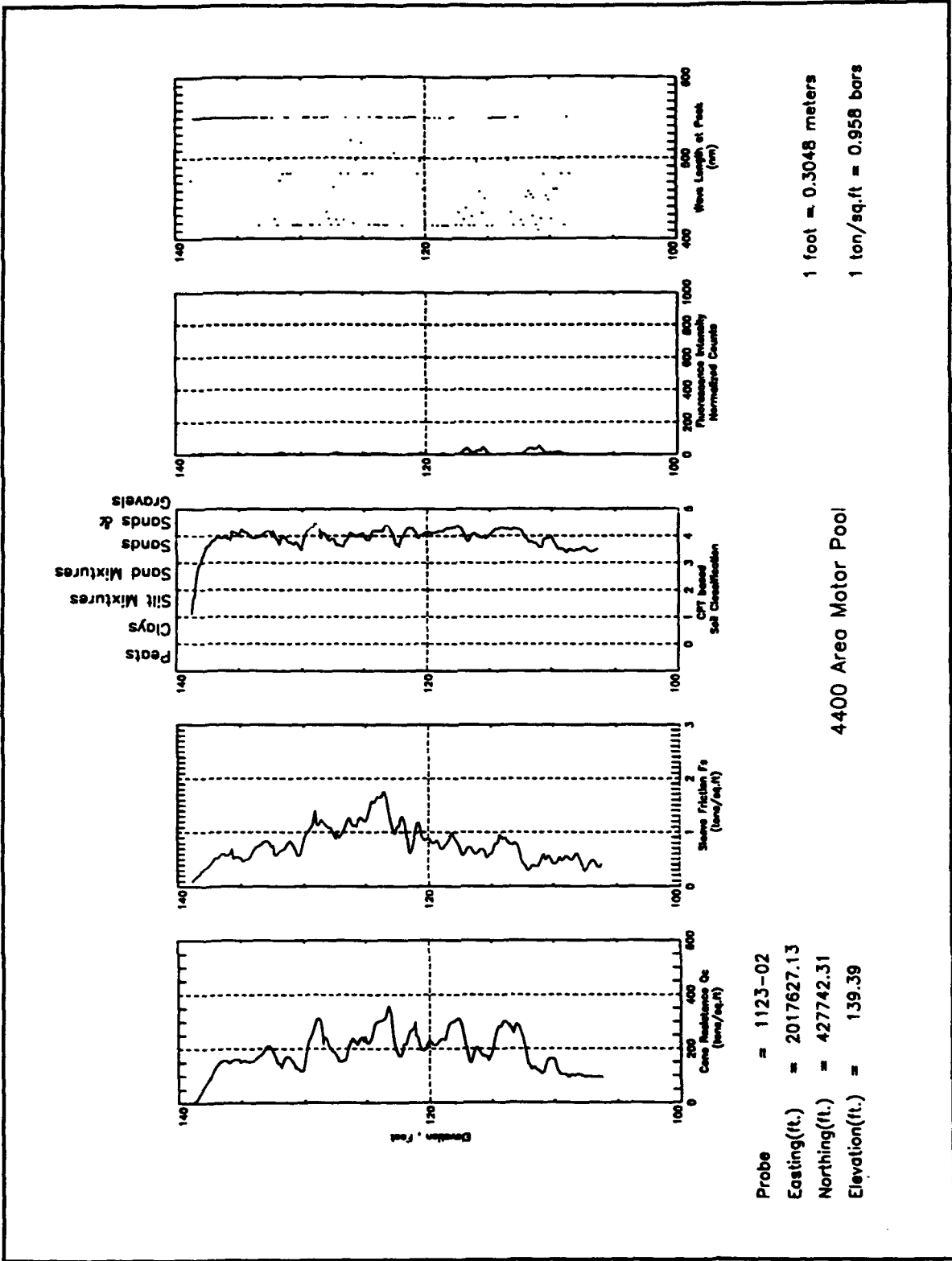

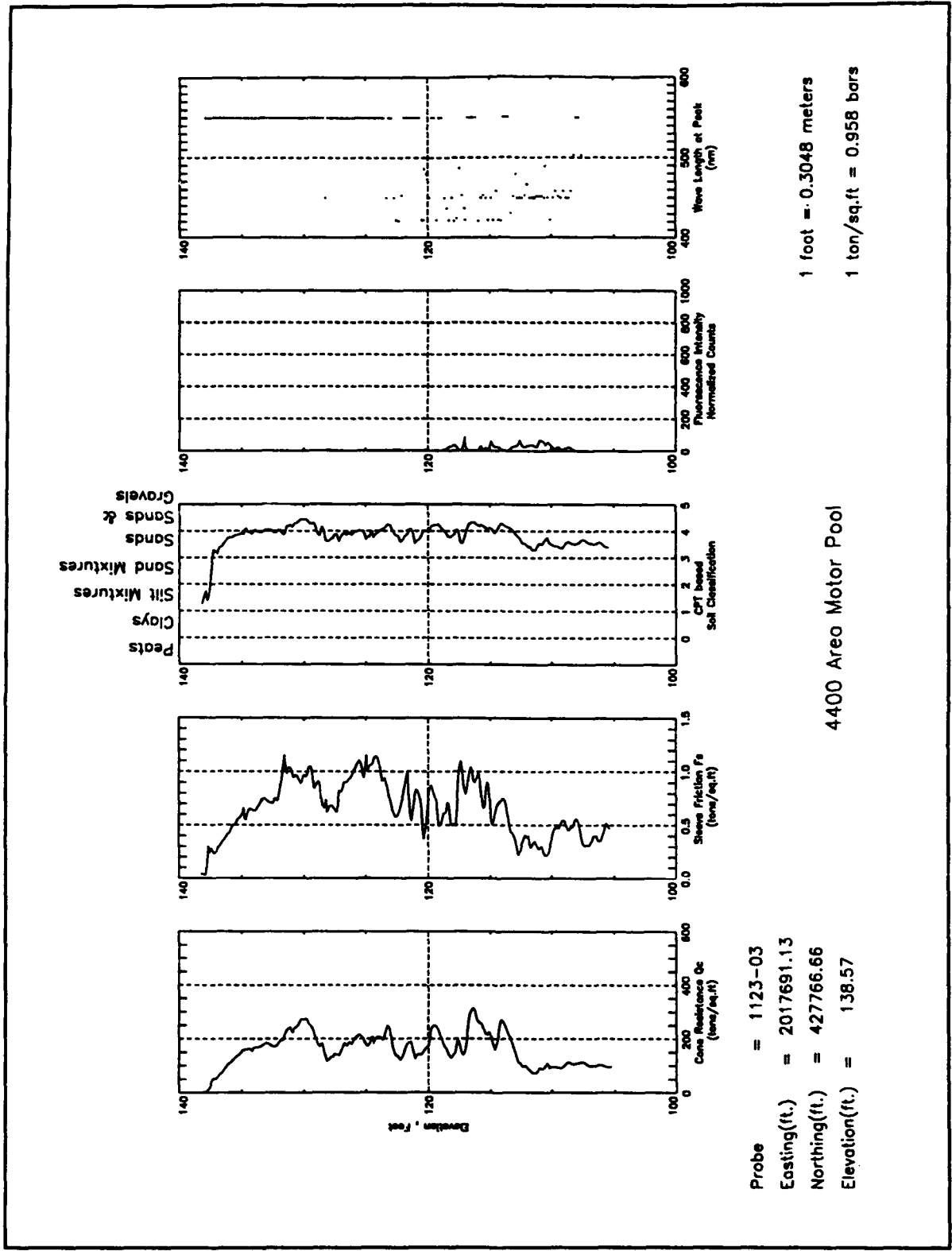

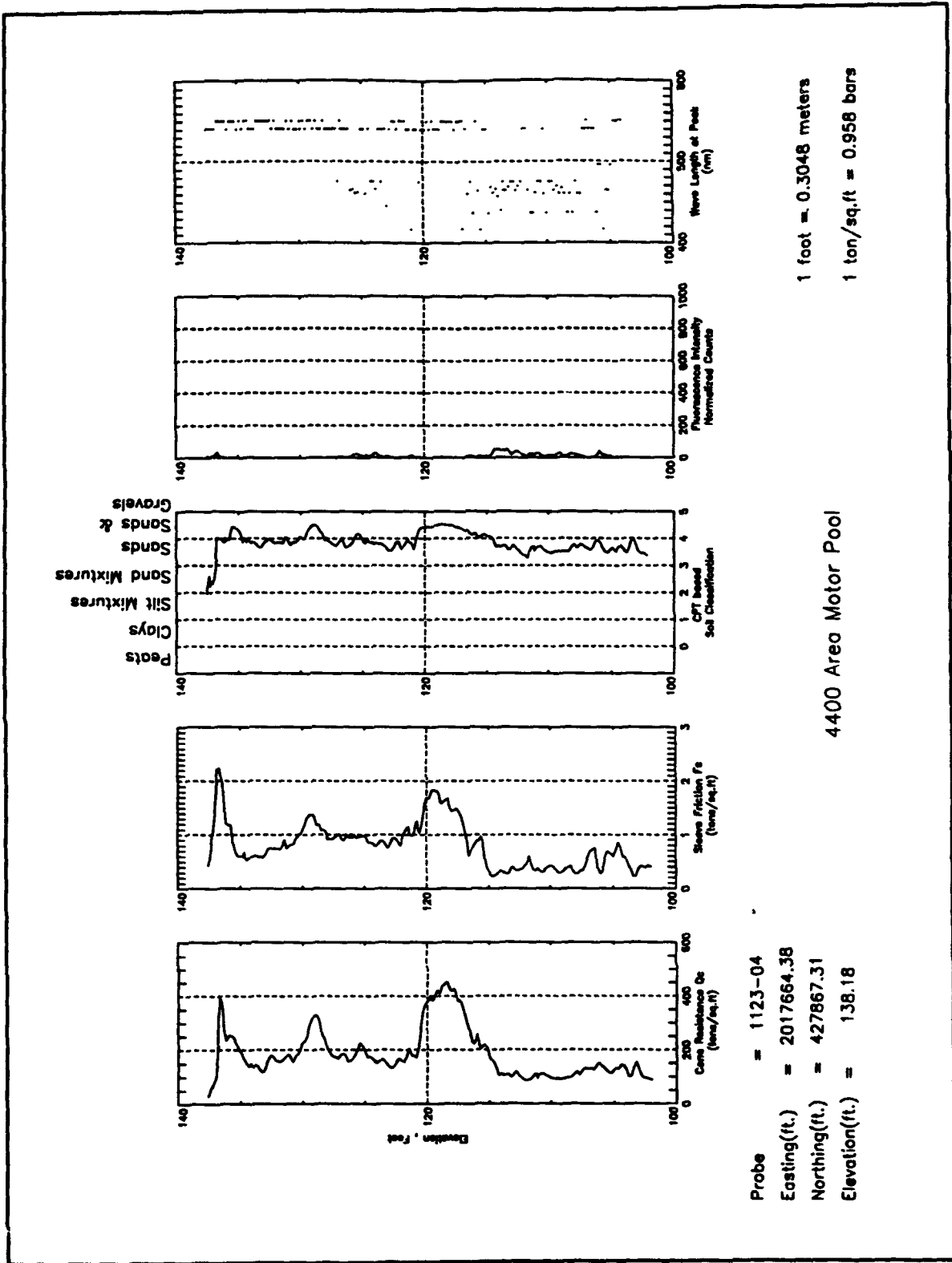

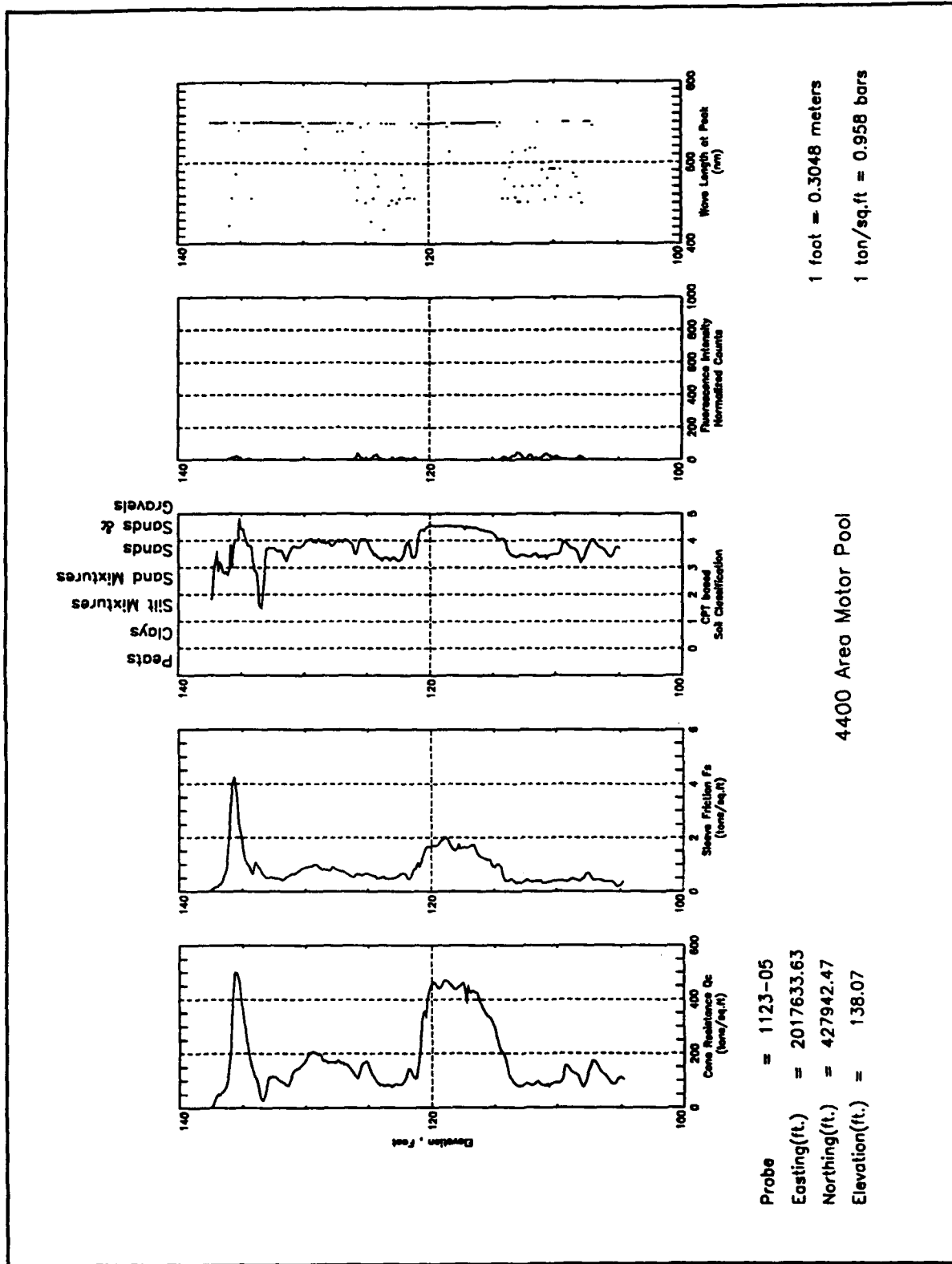

Probe = 1123-05
 Easting(ft.) = 2017633.63
 Northing(ft.) = 427942.47
 Elevation(ft.) = 138.07

4400 Area Motor Pool

1 foot = 0.3048 meters
 1 ton/sq.ft = 0.958 bars

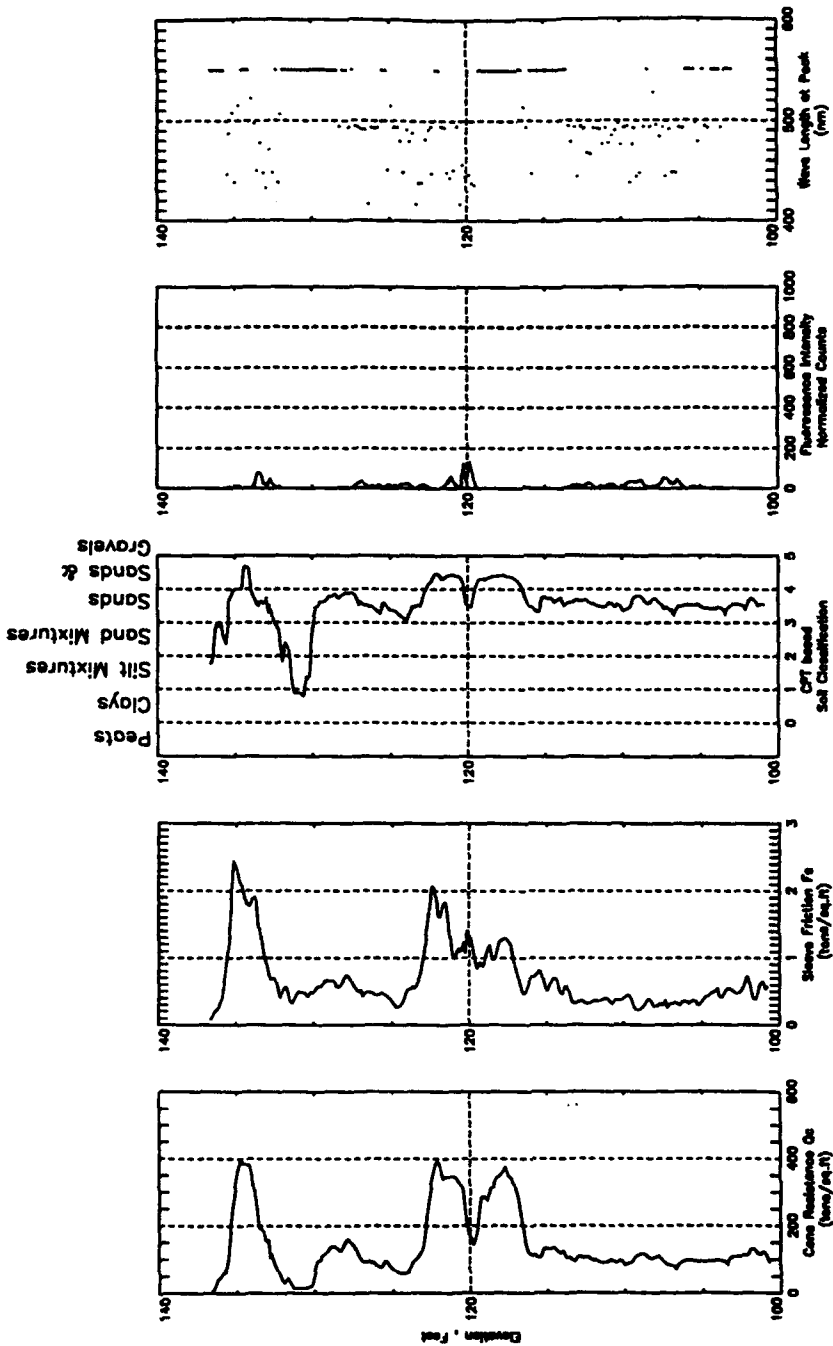

Probe = 1123-06
 Easting(ft.) = 2017593.63
 Northing(ft.) = 428015.62
 Elevation(ft.) = 137.19

4400 Area Motor Pool

1 foot = 0.3048 meters
 1 ton/sq.ft = 0.958 bars

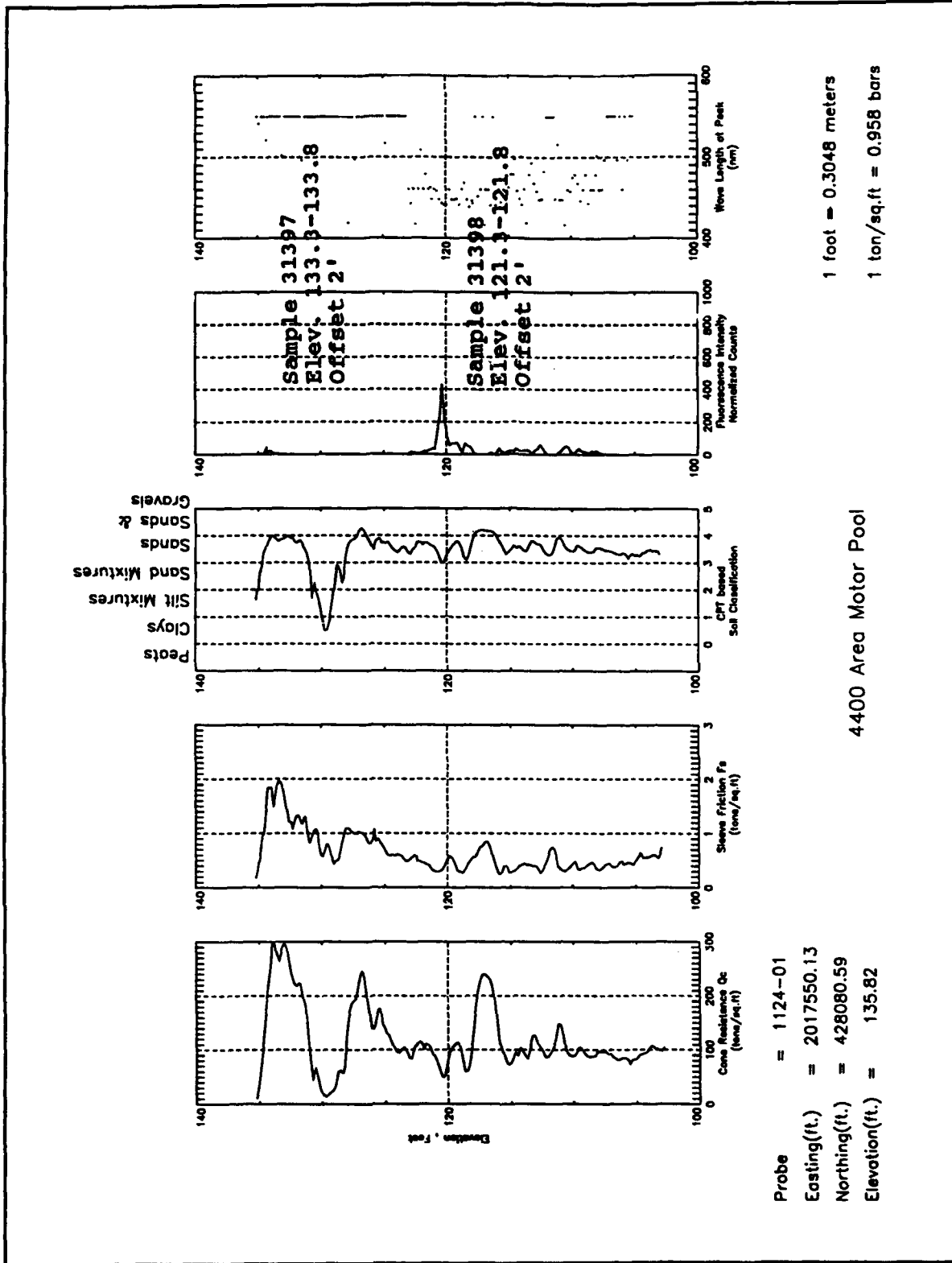

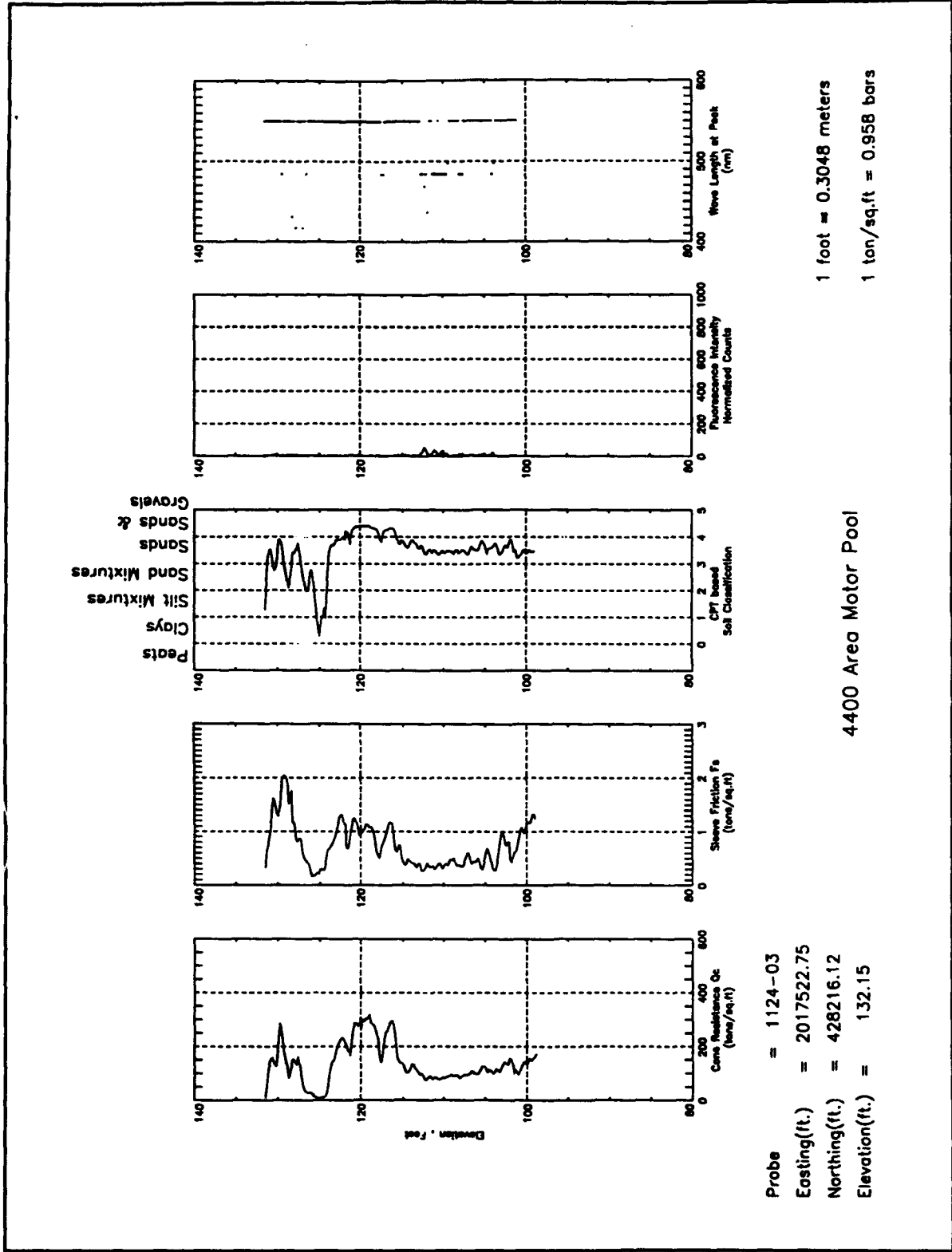

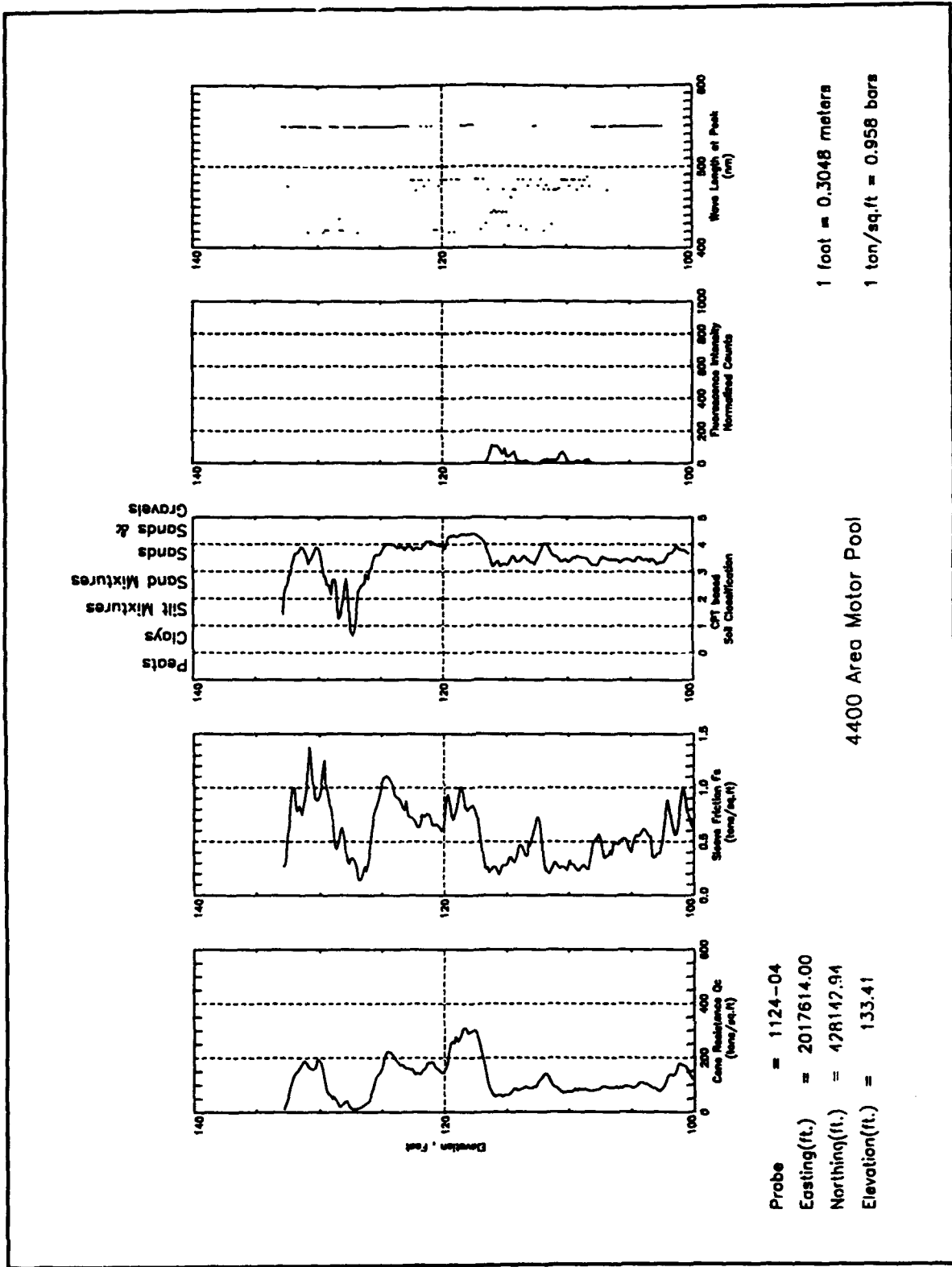

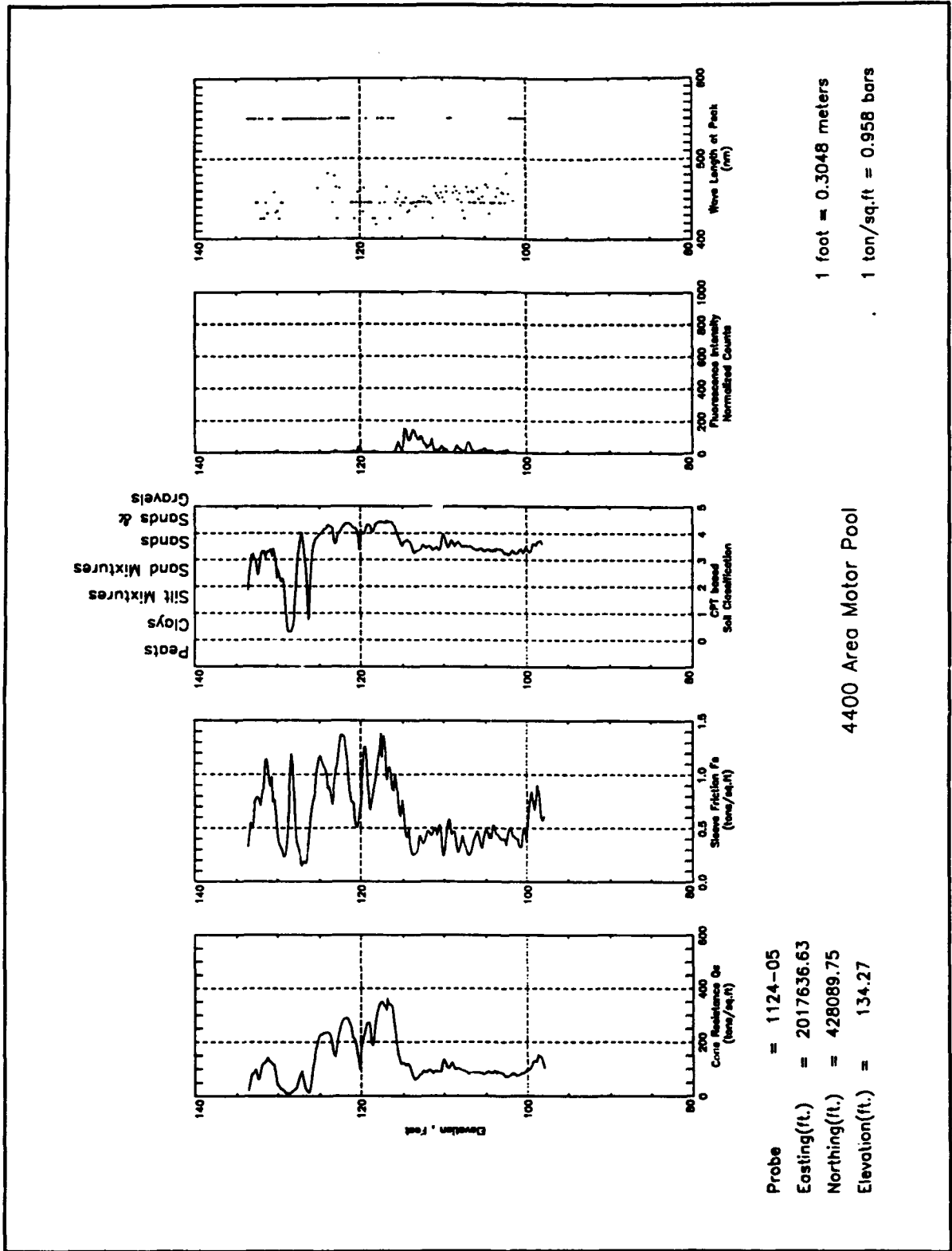

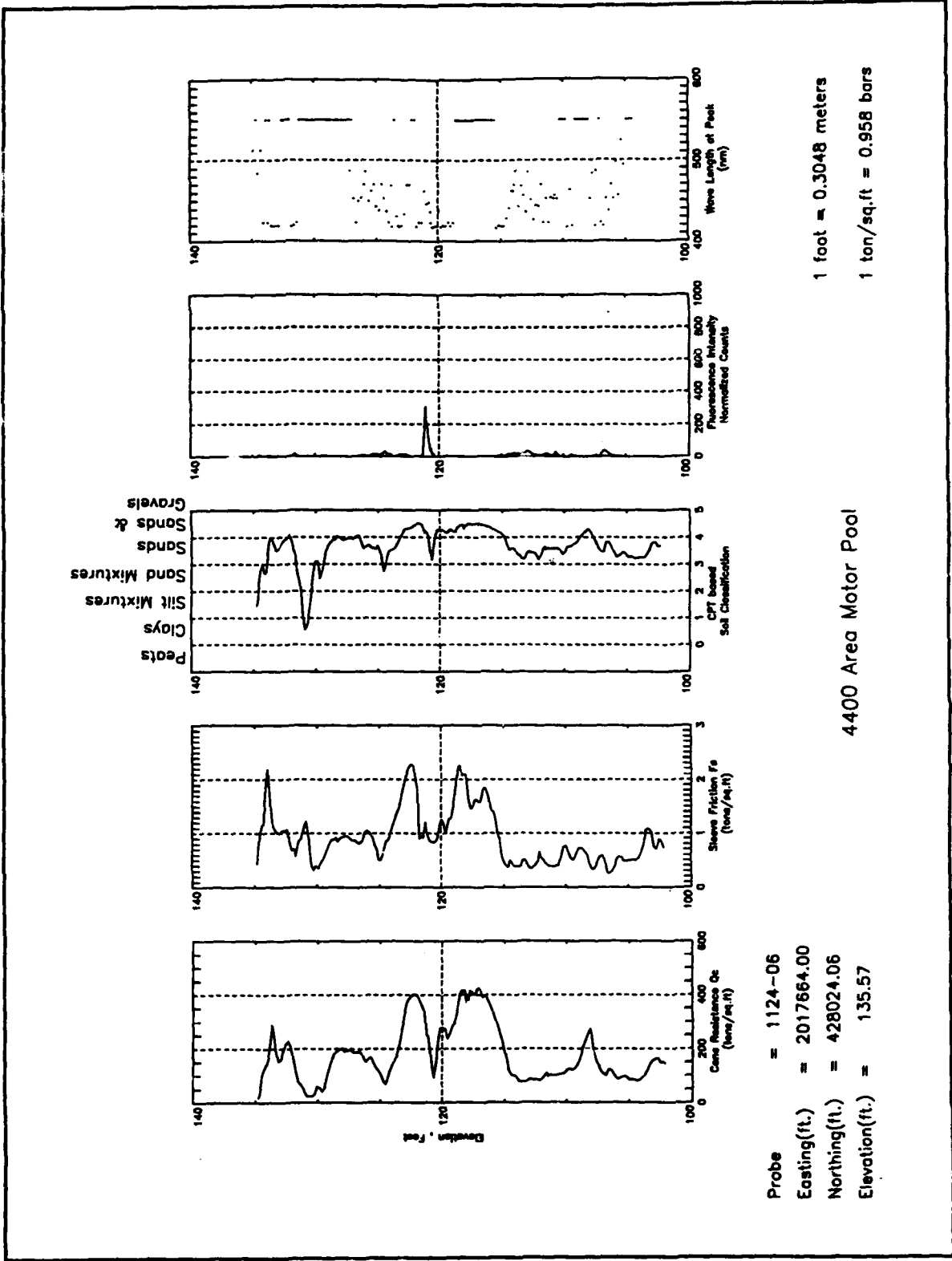

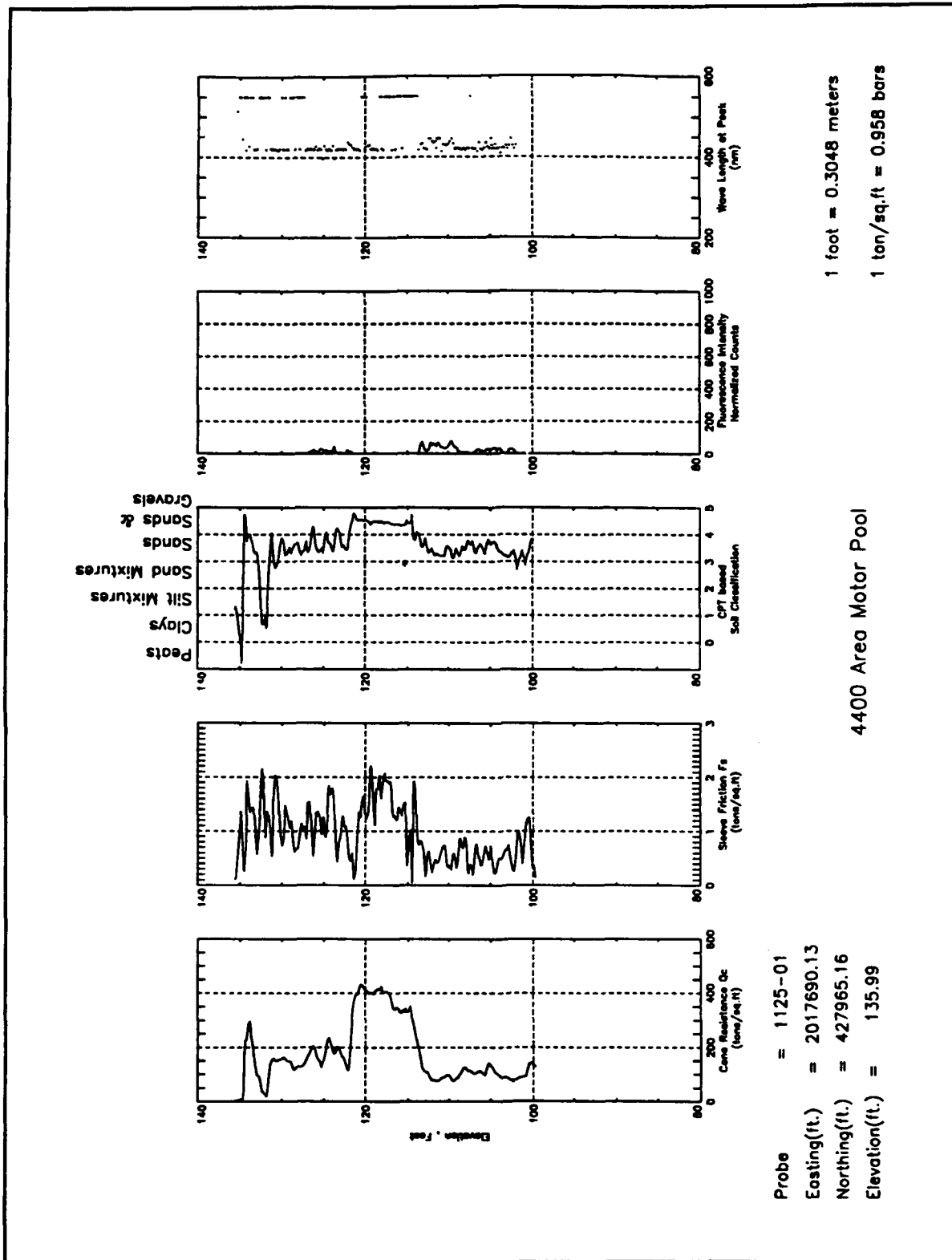

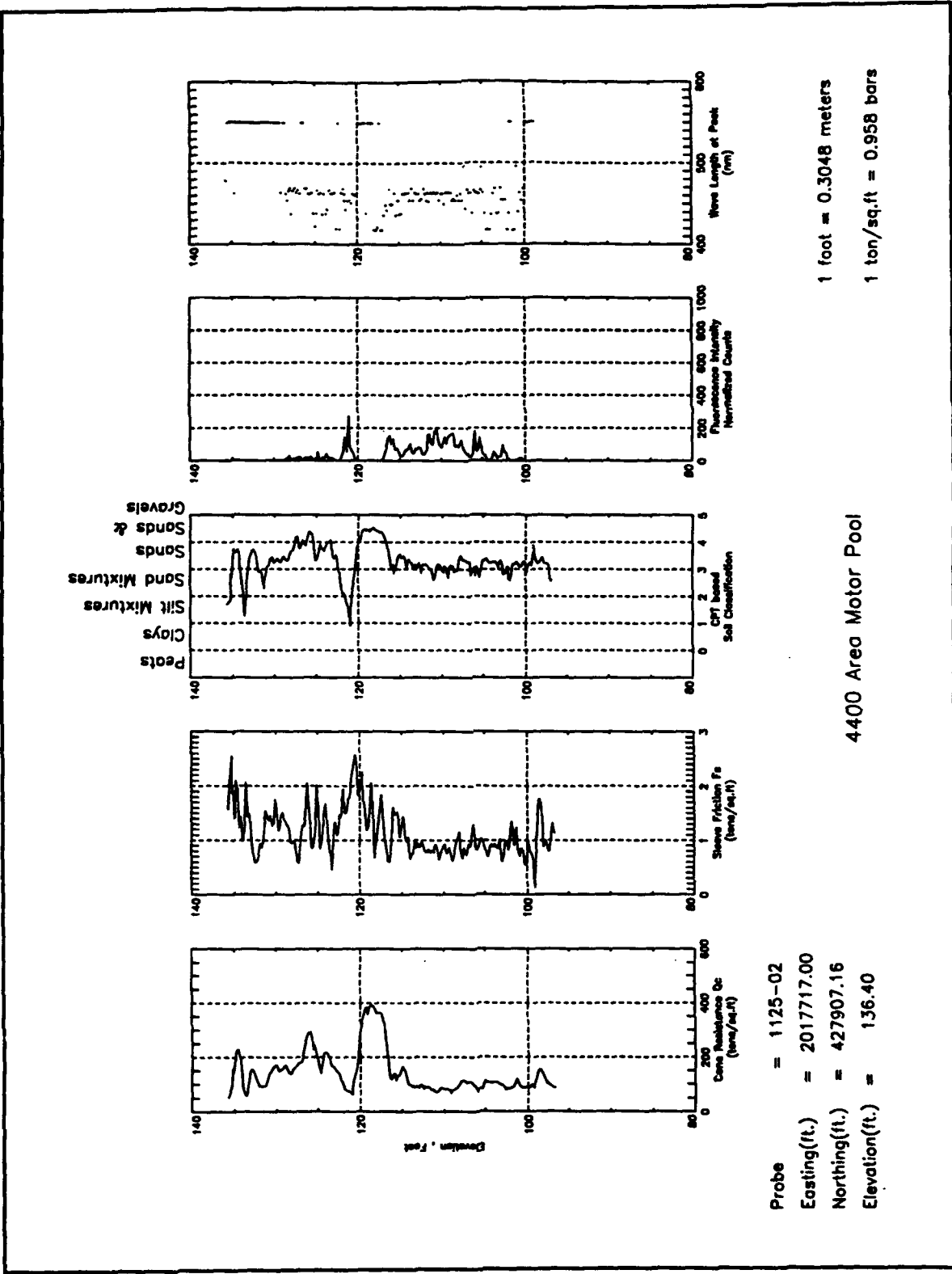

Probe = 1125-02
 Easting(ft.) = 2017717.00
 Northing(ft.) = 427907.16
 Elevation(ft.) = 136.40

4400 Area Motor Pool

1 foot = 0.3048 meters
 1 ton/sq.ft = 0.958 bars

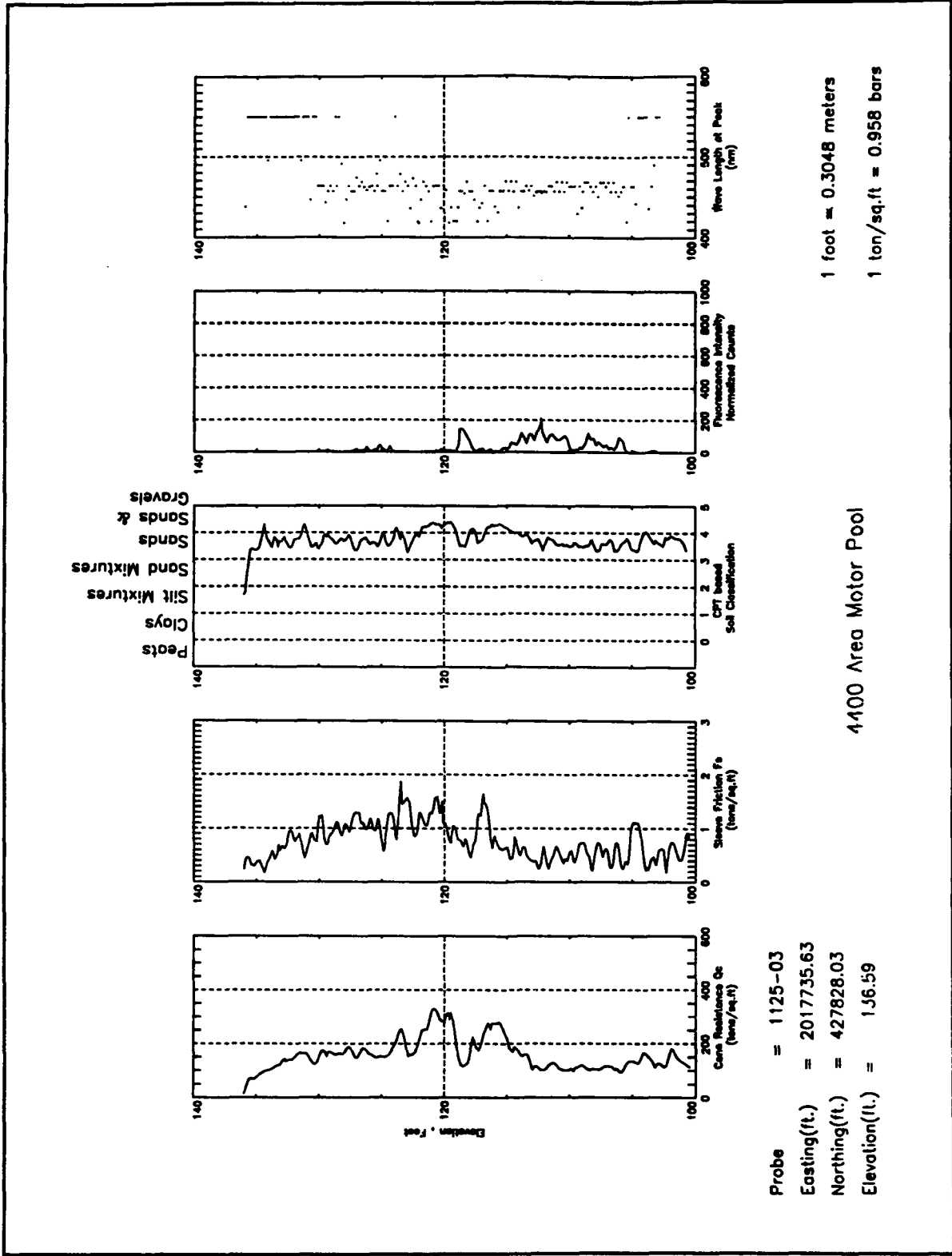

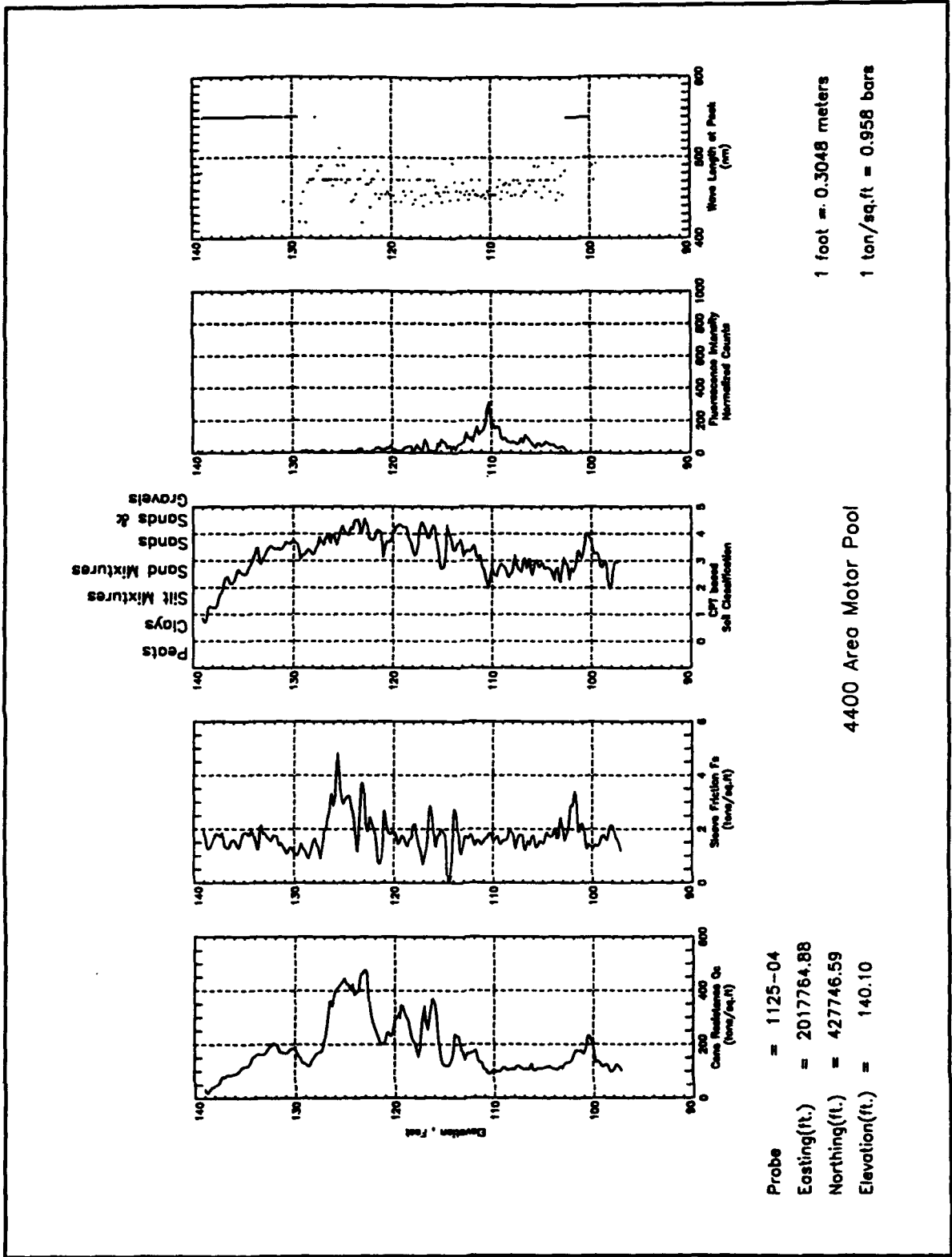

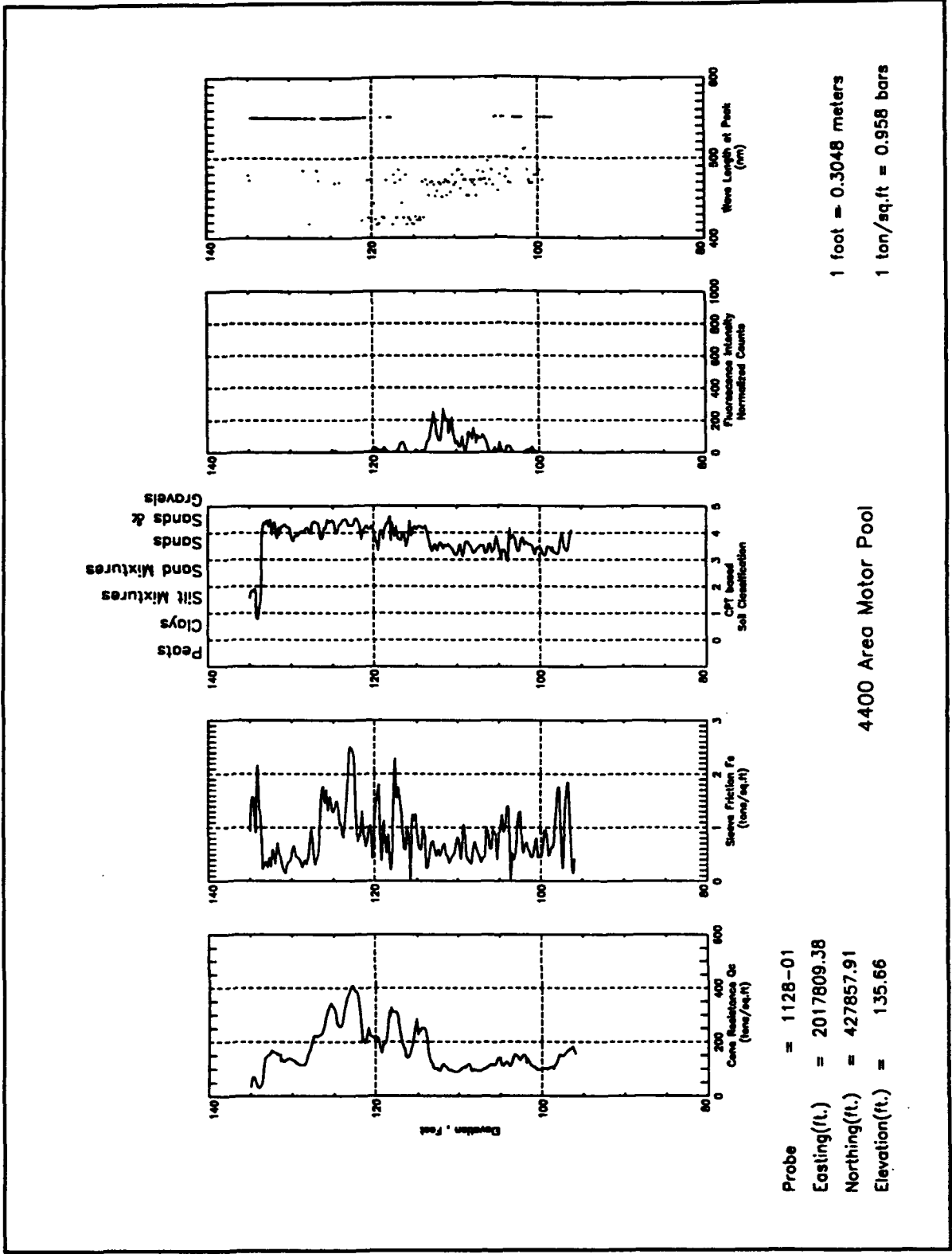

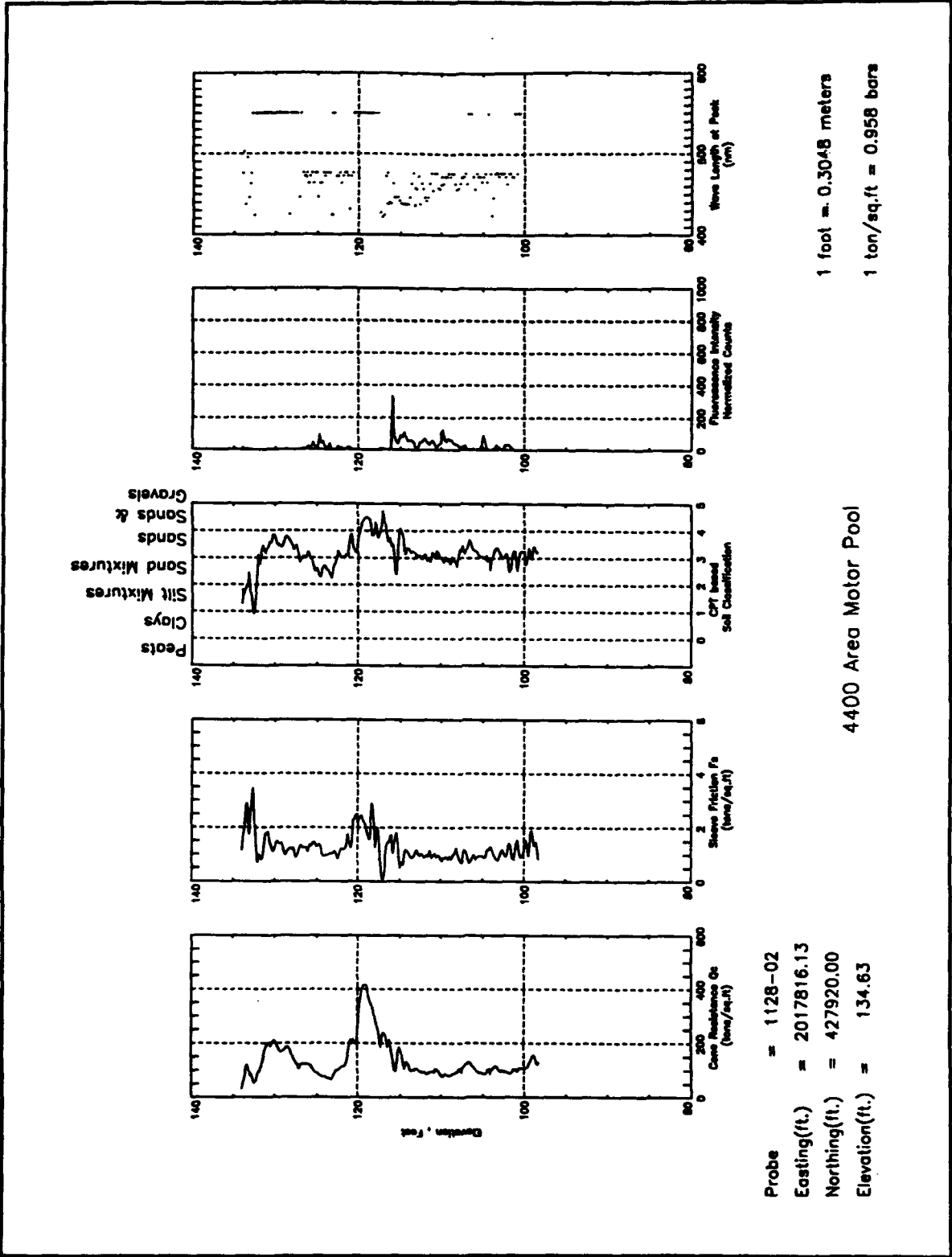

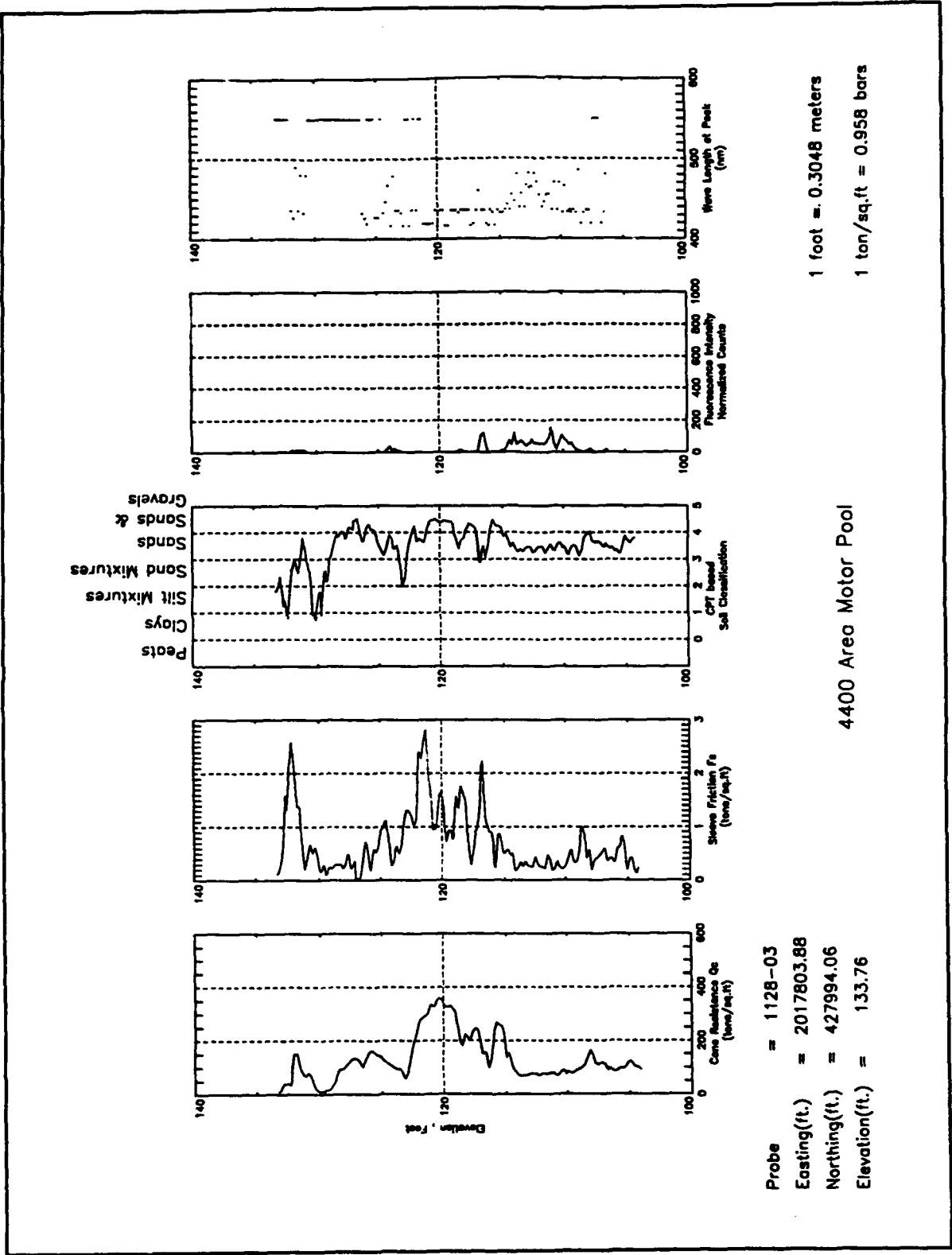

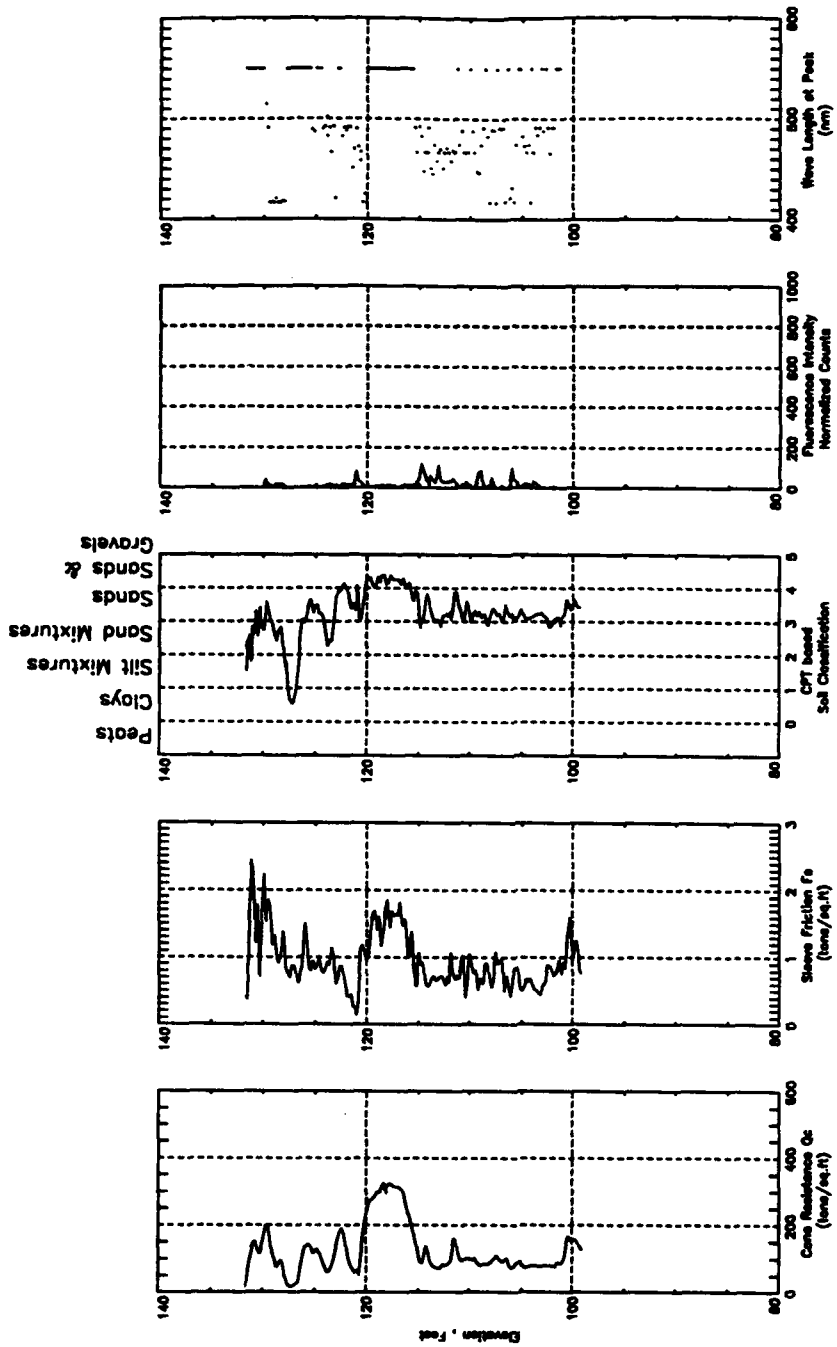

Probe = 1128-04
 Easting(ft.) = 2017789.25
 Northing(ft.) = 428063.44
 Elevation(ft.) = 132.31

4400 Area Motor Pool

1 foot = 0.3048 meters
 1 ton/sq.ft = 0.958 bars

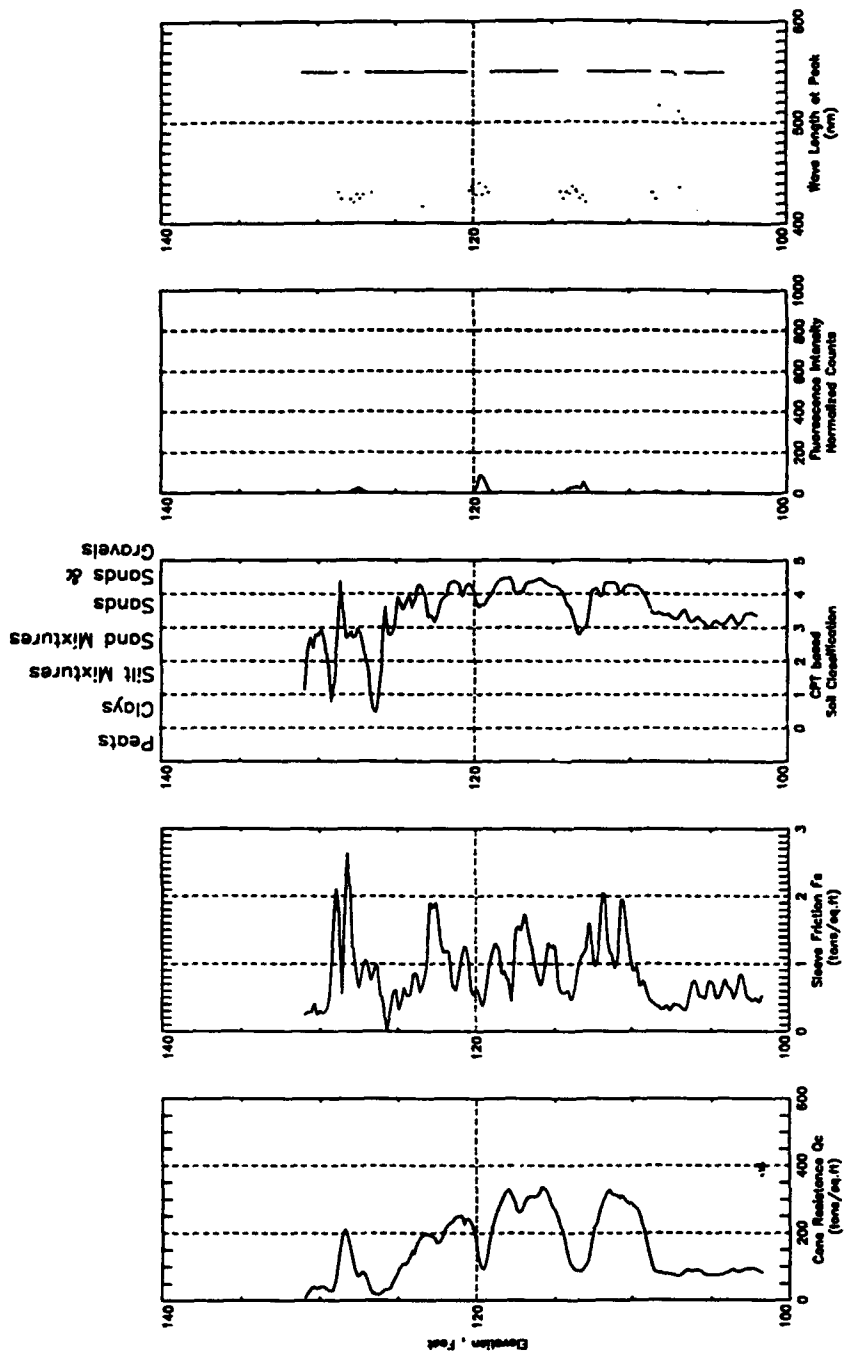

1 foot = 0.3048 meters
 1 ton/sq.ft = 0.958 bars

4400 Area Motor Pool

Probe = 1128-05
 Easting(ft.) = 201770.00
 Northing(ft.) = 428119.81
 Elevation(ft.) = 131.60

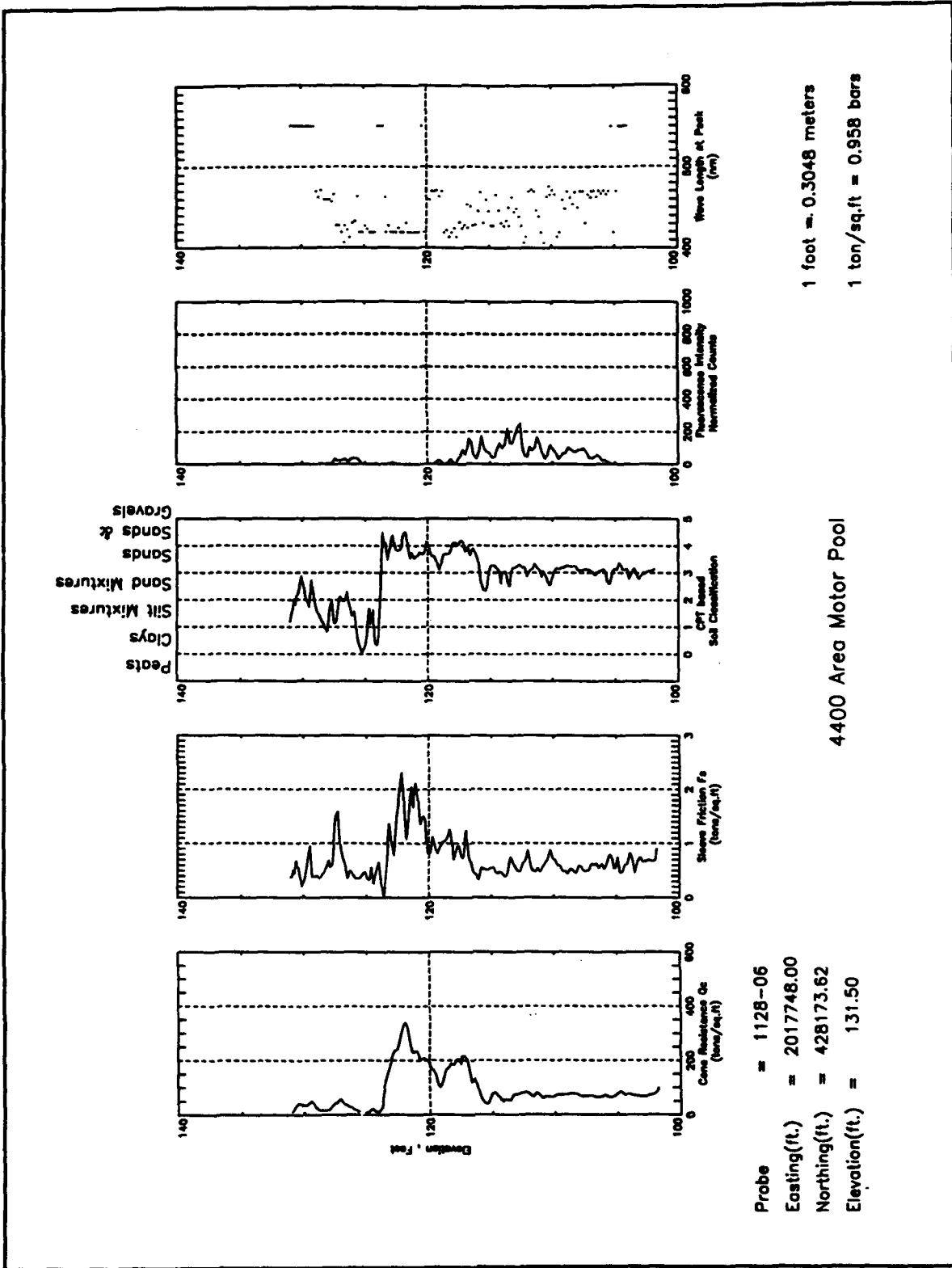

Probe = 1128-06
 Easting(ft.) = 2017748.00
 Northing(ft.) = 428173.62
 Elevation(ft.) = 131.50

4400 Area Motor Pool

1 foot = 0.3048 meters
 1 ton/sq.ft = 0.958 bars

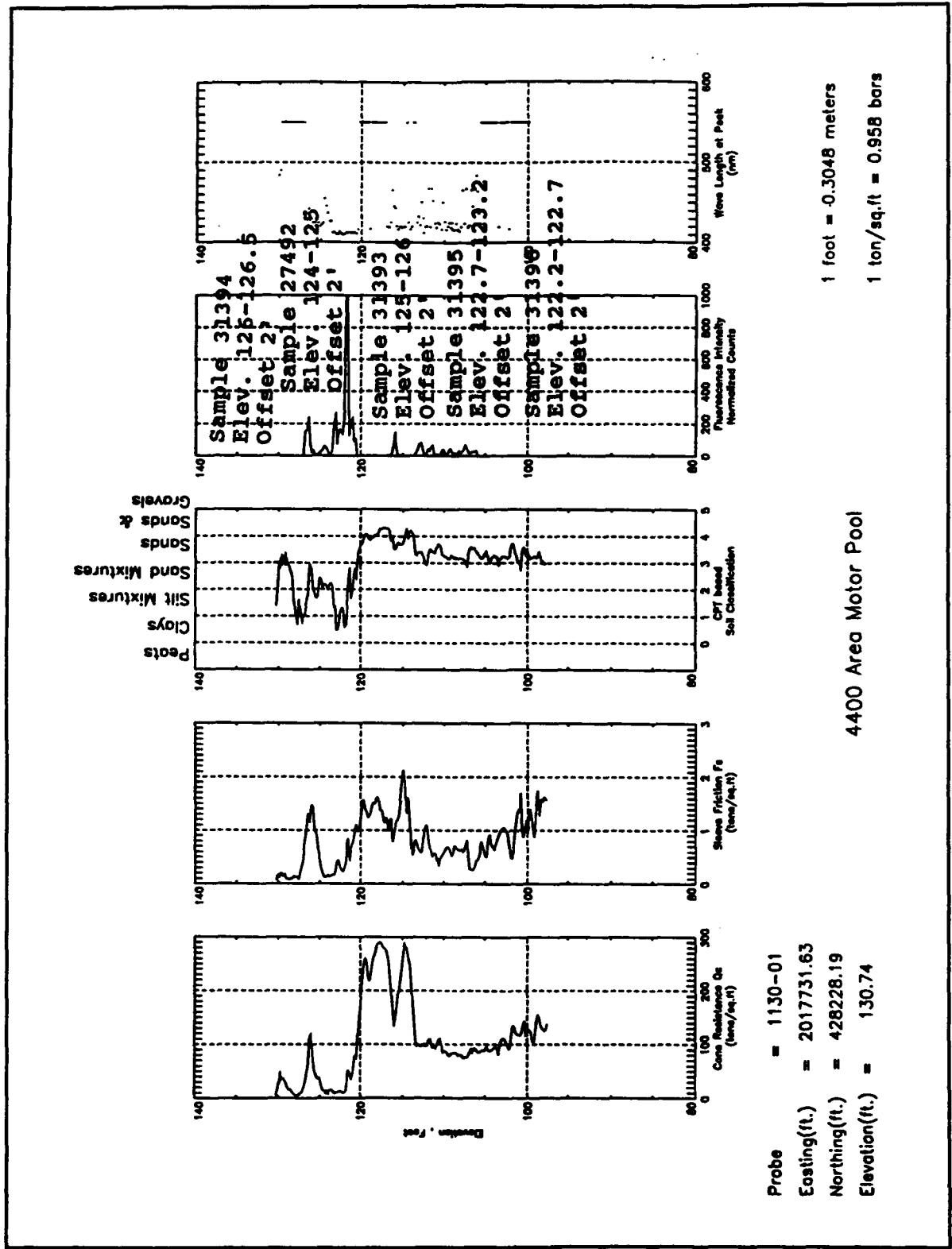

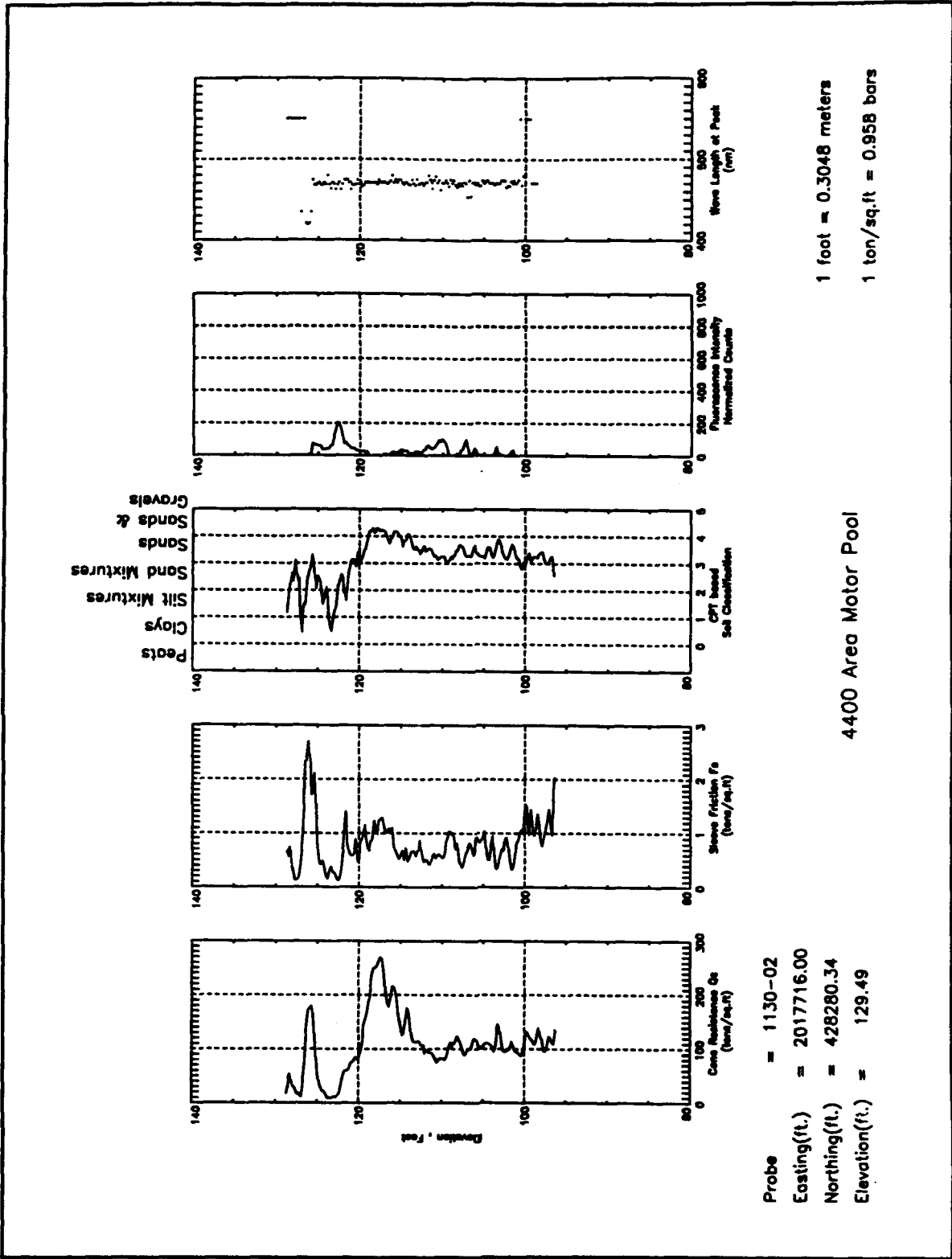

Probe = 1130-02
 Easting(ft.) = 2017716.00
 Northing(ft.) = 428280.34
 Elevation(ft.) = 129.49

1 foot = 0.3048 meters
 1 ton/sq.ft = 0.958 bars

4400 Area Motor Pool

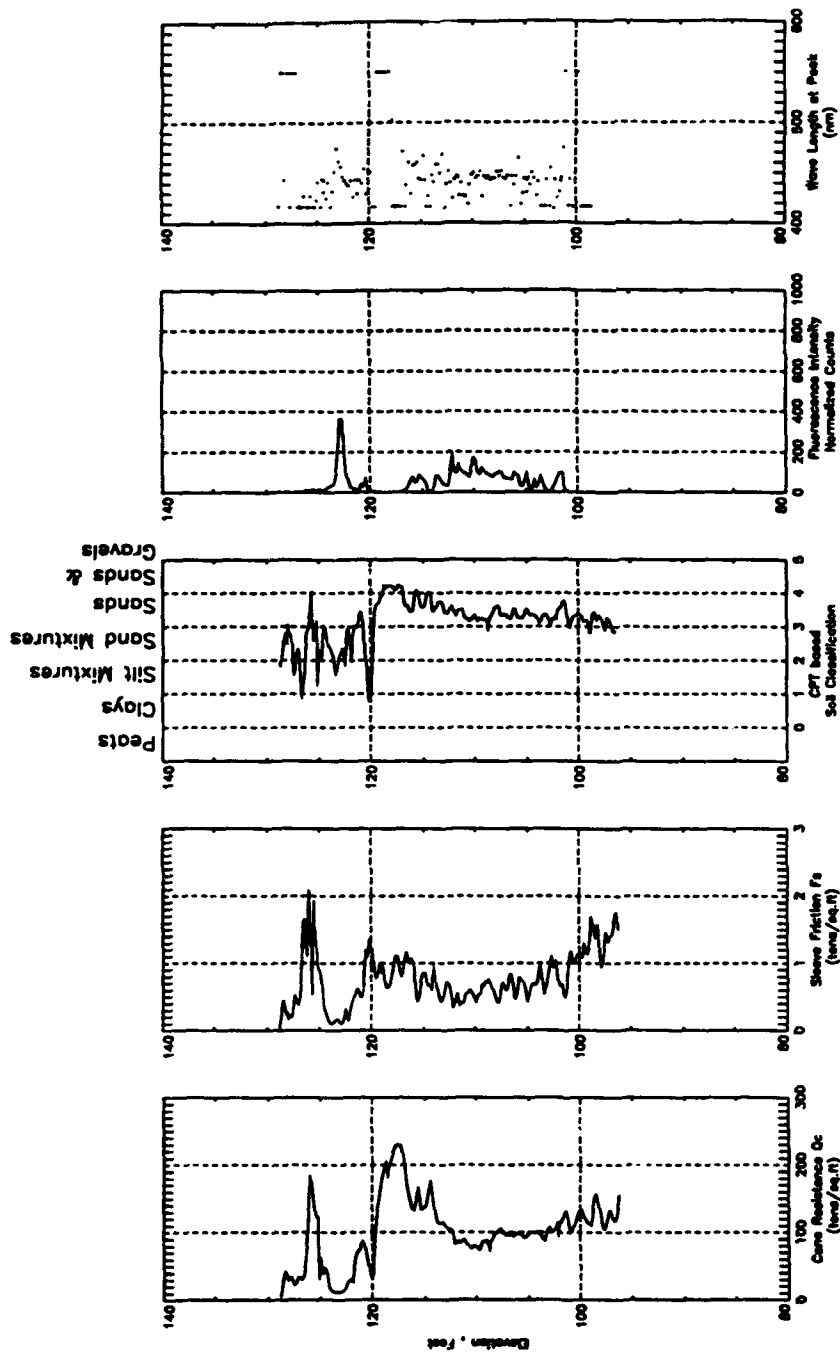

Probe = 1130-03
 Easting(ft.) = 2017715.38
 Northing(ft.) = 428282.81
 Elevation(ft.) = 129.44

1 foot = 0.3048 meters
 1 ton/sq.ft = 0.958 bars

4400 Area Motor Pool

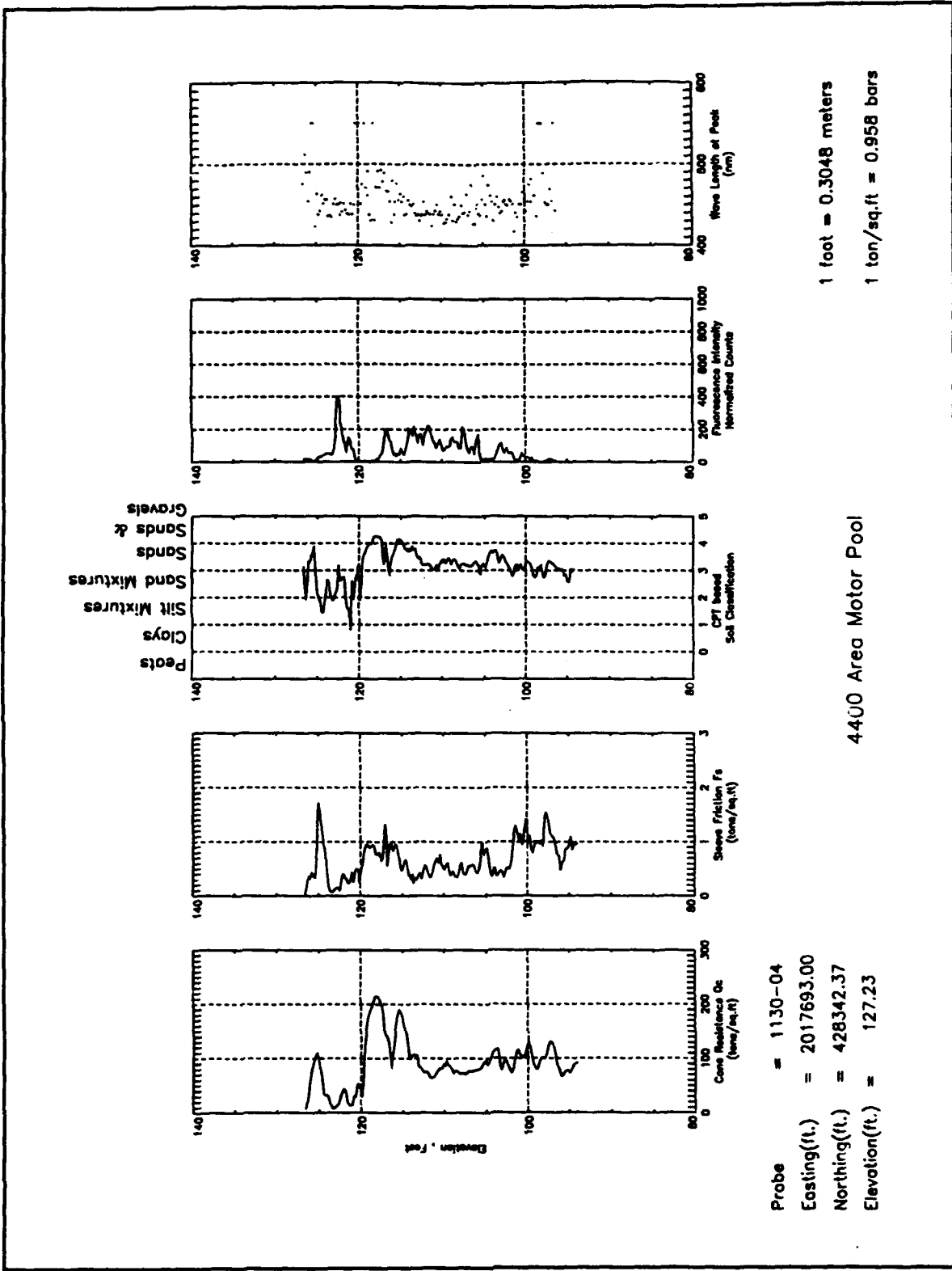

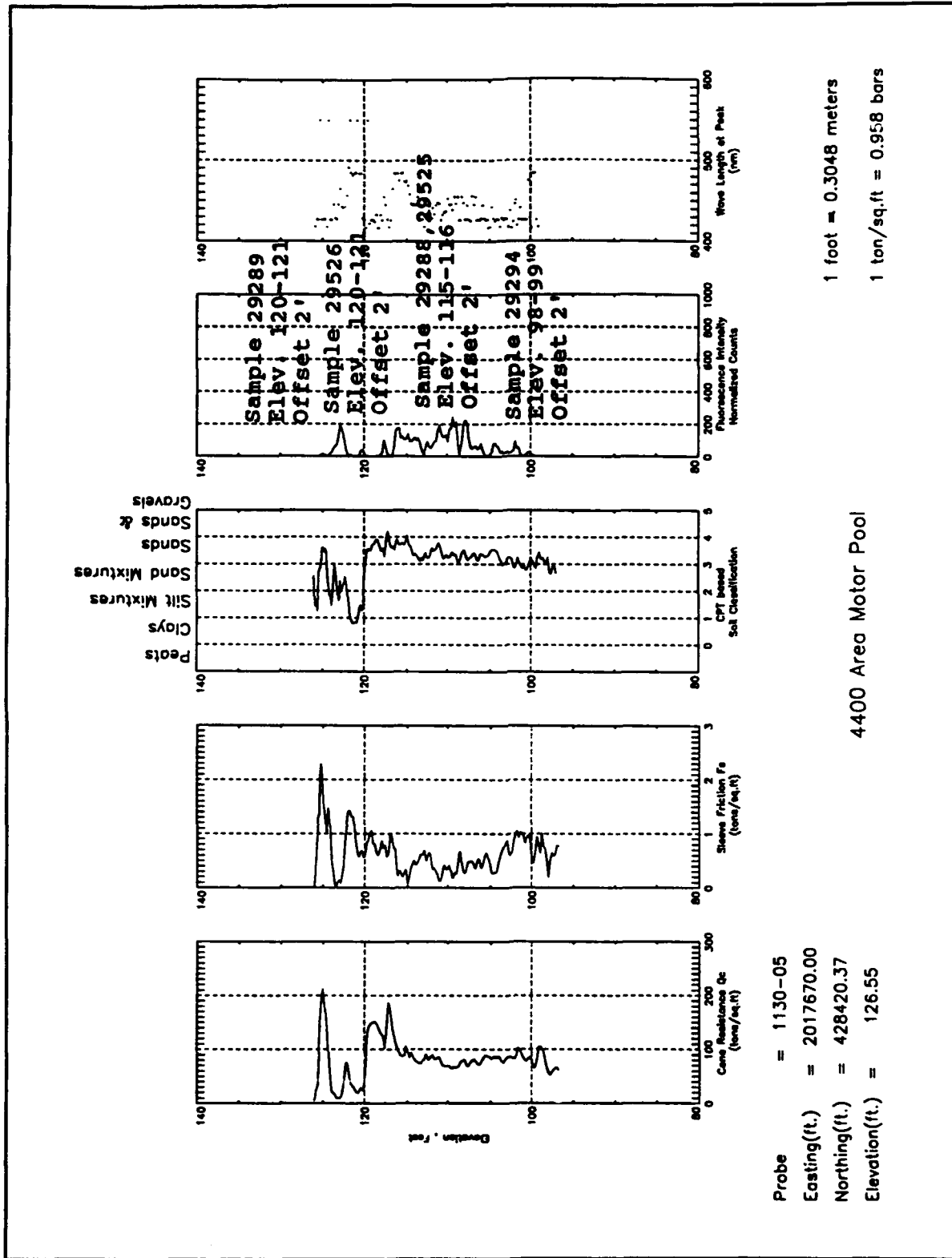

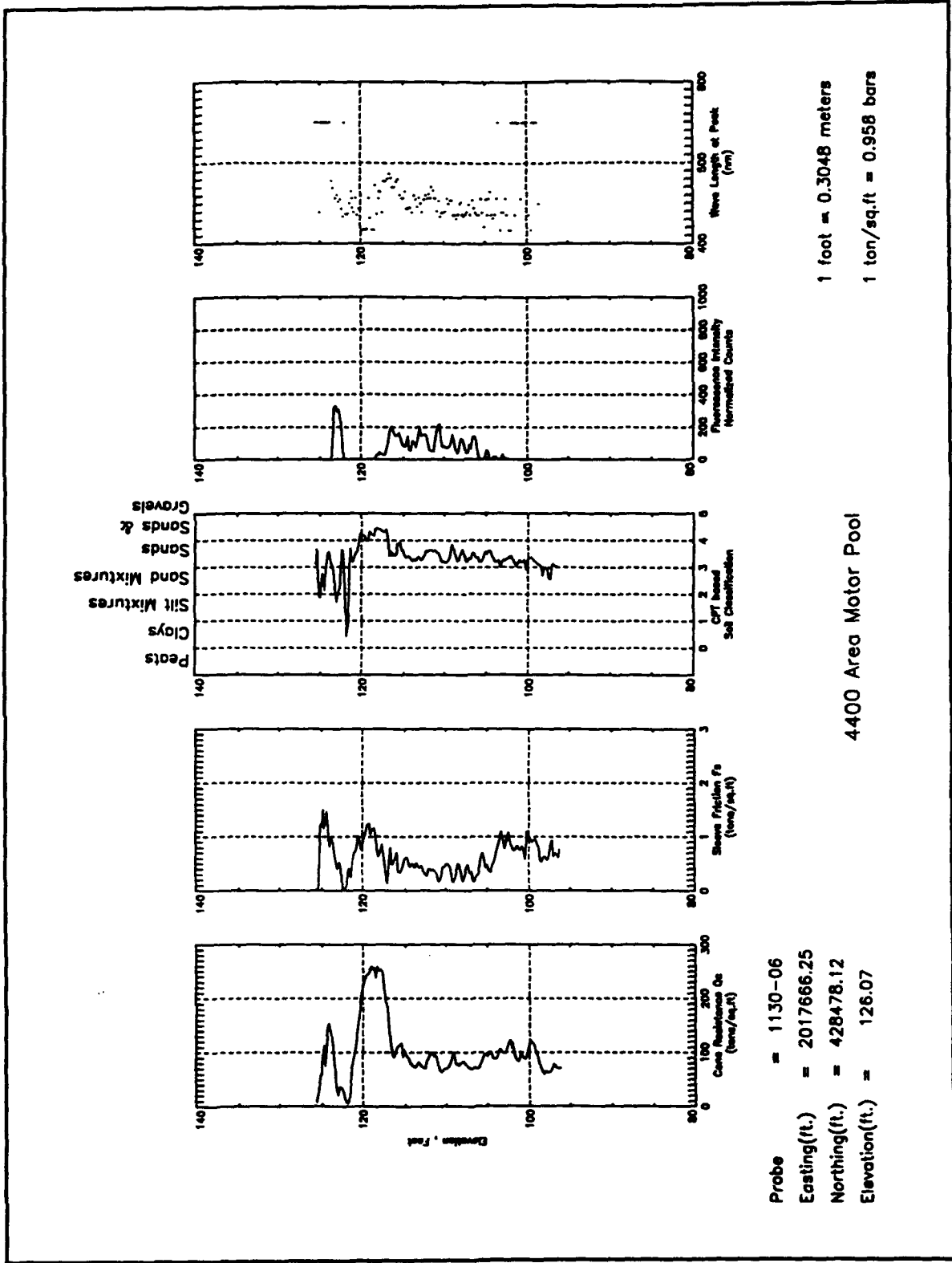

Probe = 1130-06
 Easting(ft.) = 2017666.25
 Northing(ft.) = 428478.12
 Elevation(ft.) = 126.07

4400 Area Motor Pool
 1 foot = 0.3048 meters
 1 ton/sq.ft = 0.958 bars

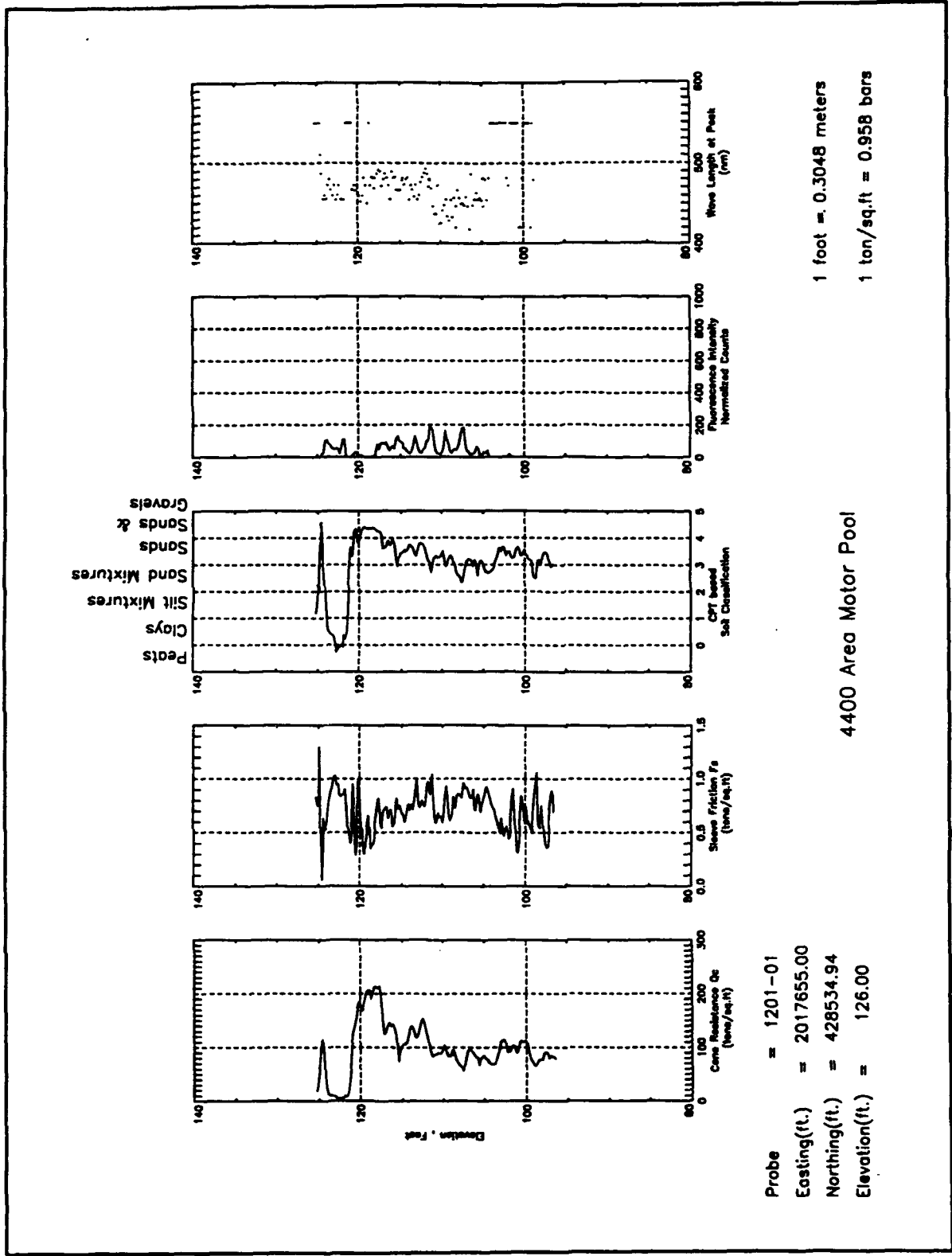

1 foot = 0.3048 meters
 1 ton/sq.ft = 0.958 bars

4400 Area Motor Pool

Probe = 1201-01
 Easting(ft.) = 2017655.00
 Northing(ft.) = 428534.94
 Elevation(ft.) = 126.00

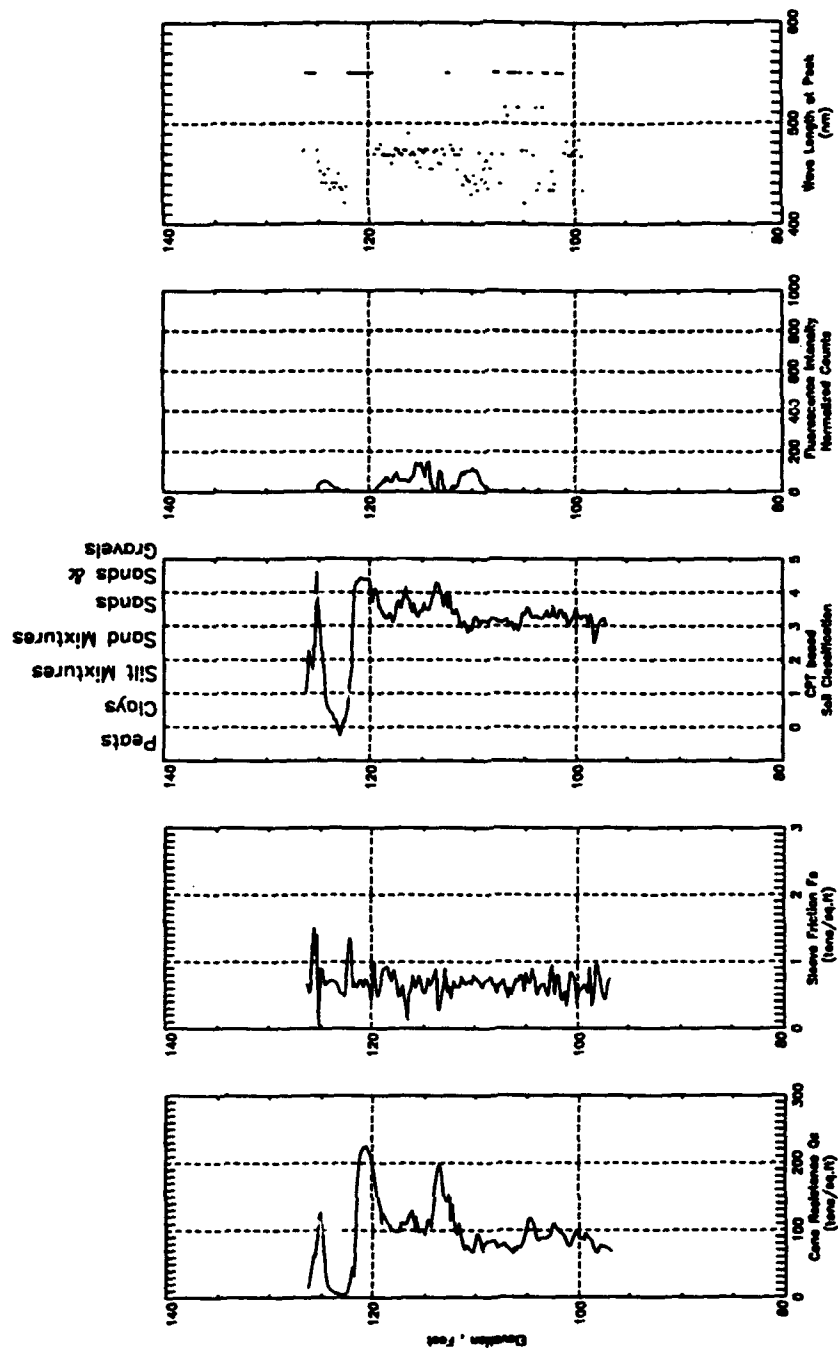

Probe = 1201-02
 Easting(ft.) = 2017643.25
 Northing(ft.) = 428599.12
 Elevation(ft.) = 127.00

1 foot = 0.3048 meters
 1 ton/sq.ft = 0.958 bars

4400 Area Motor Pool

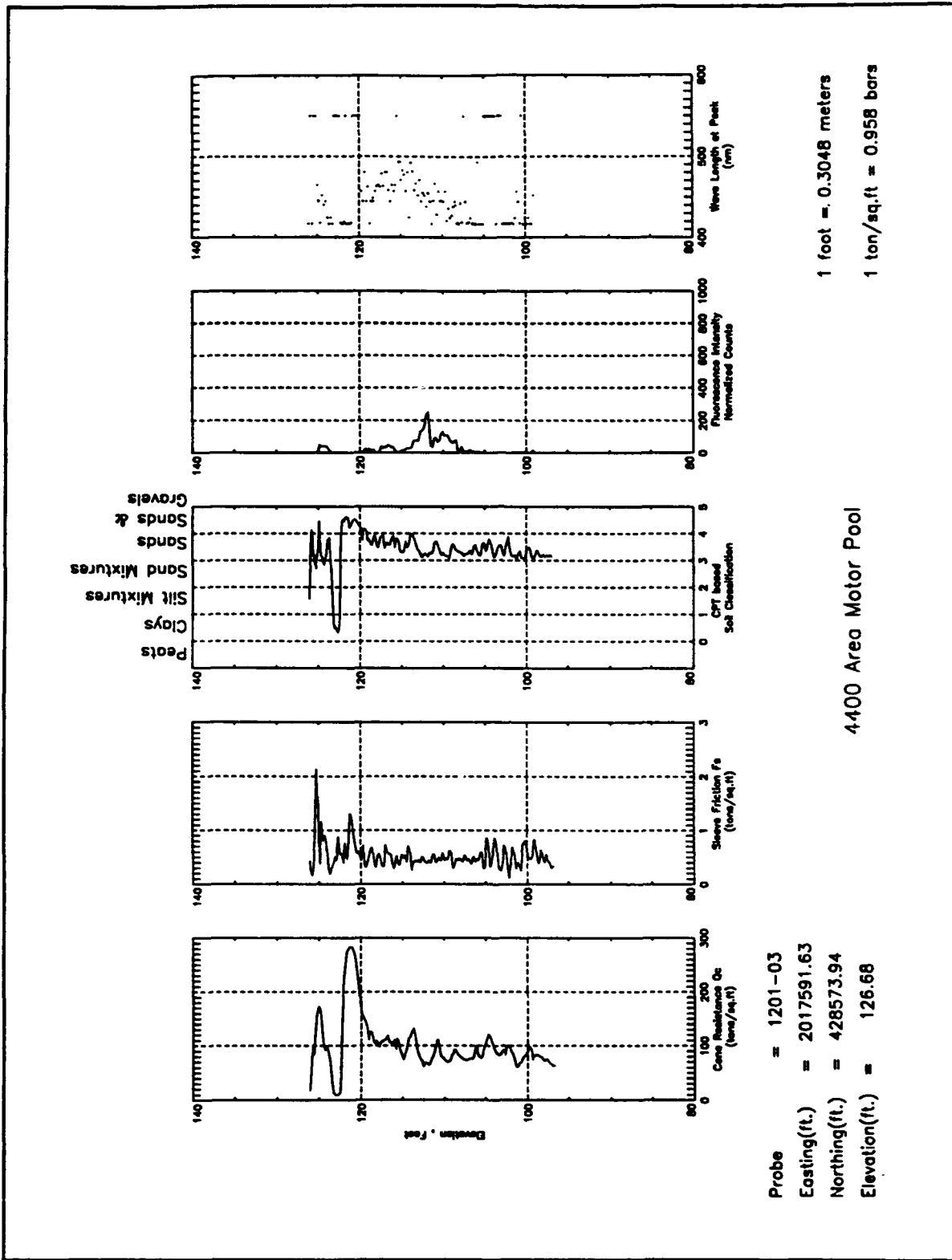

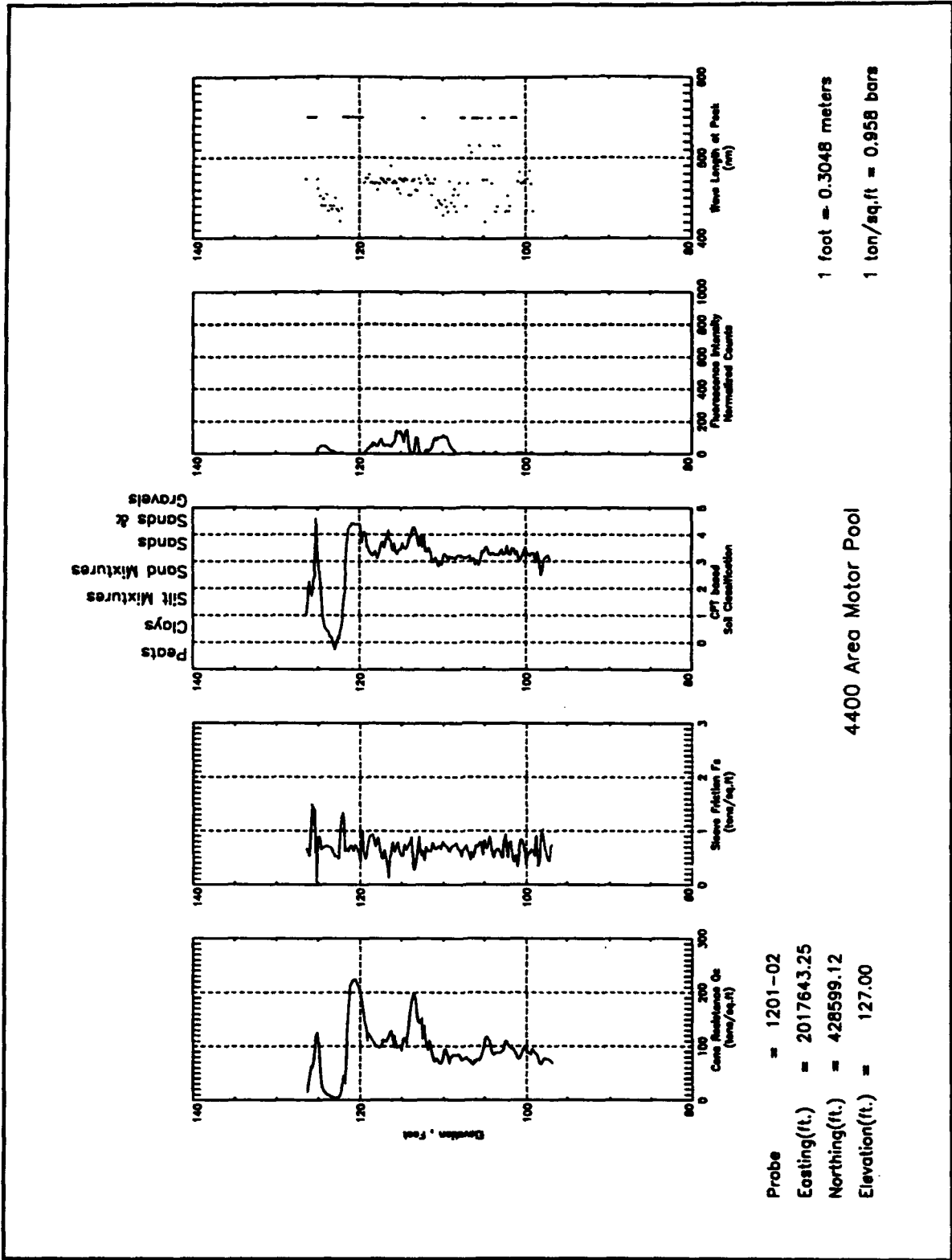

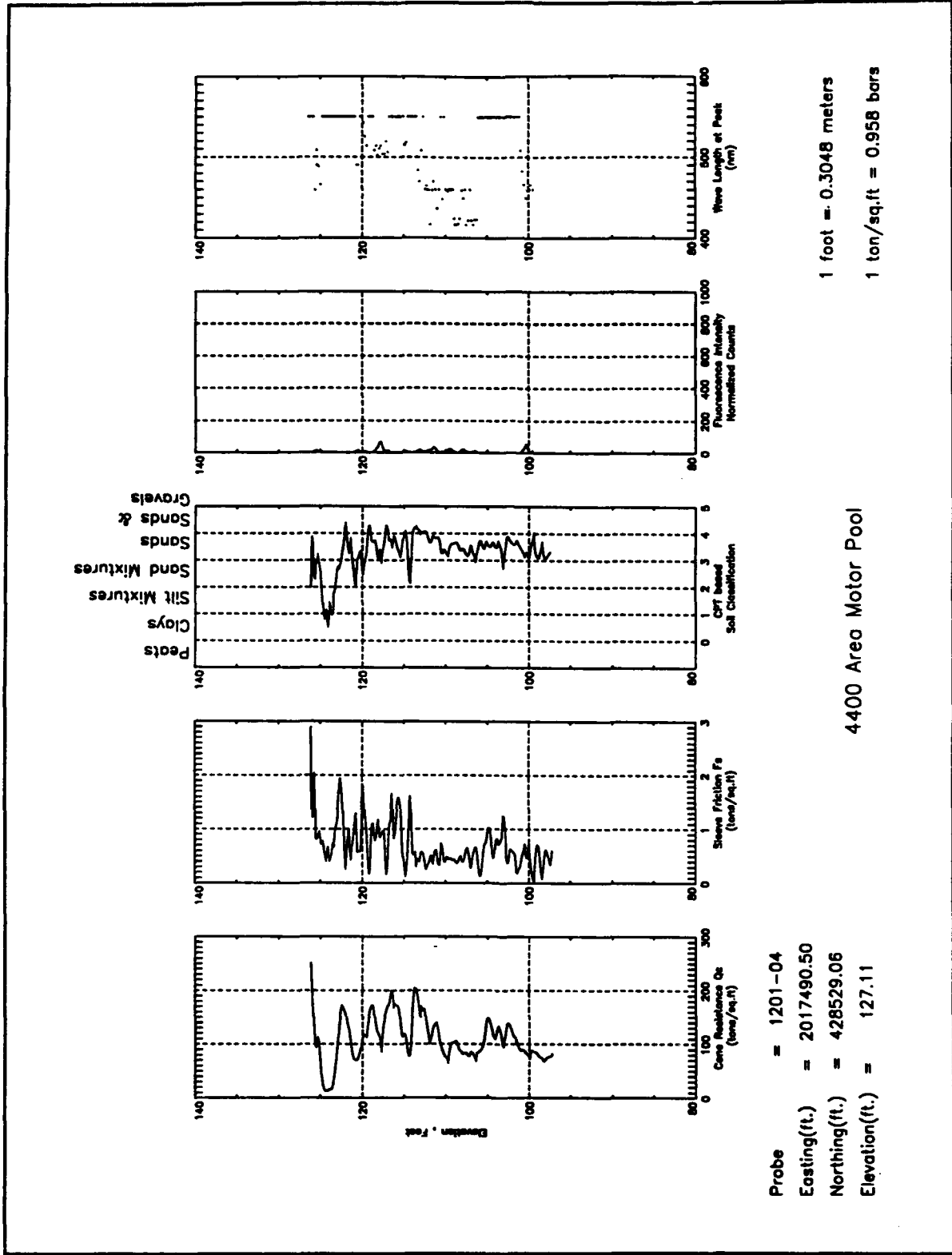

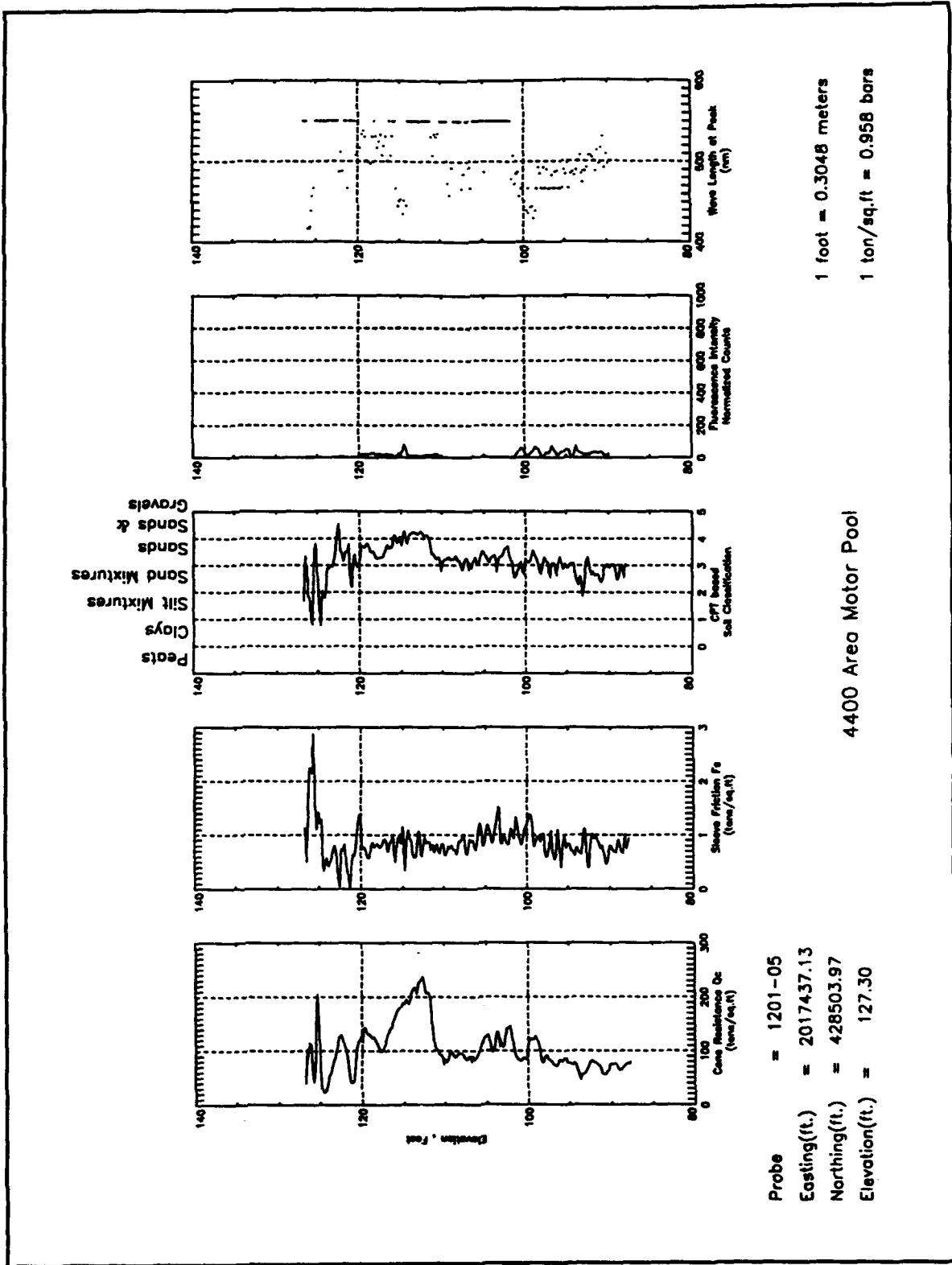

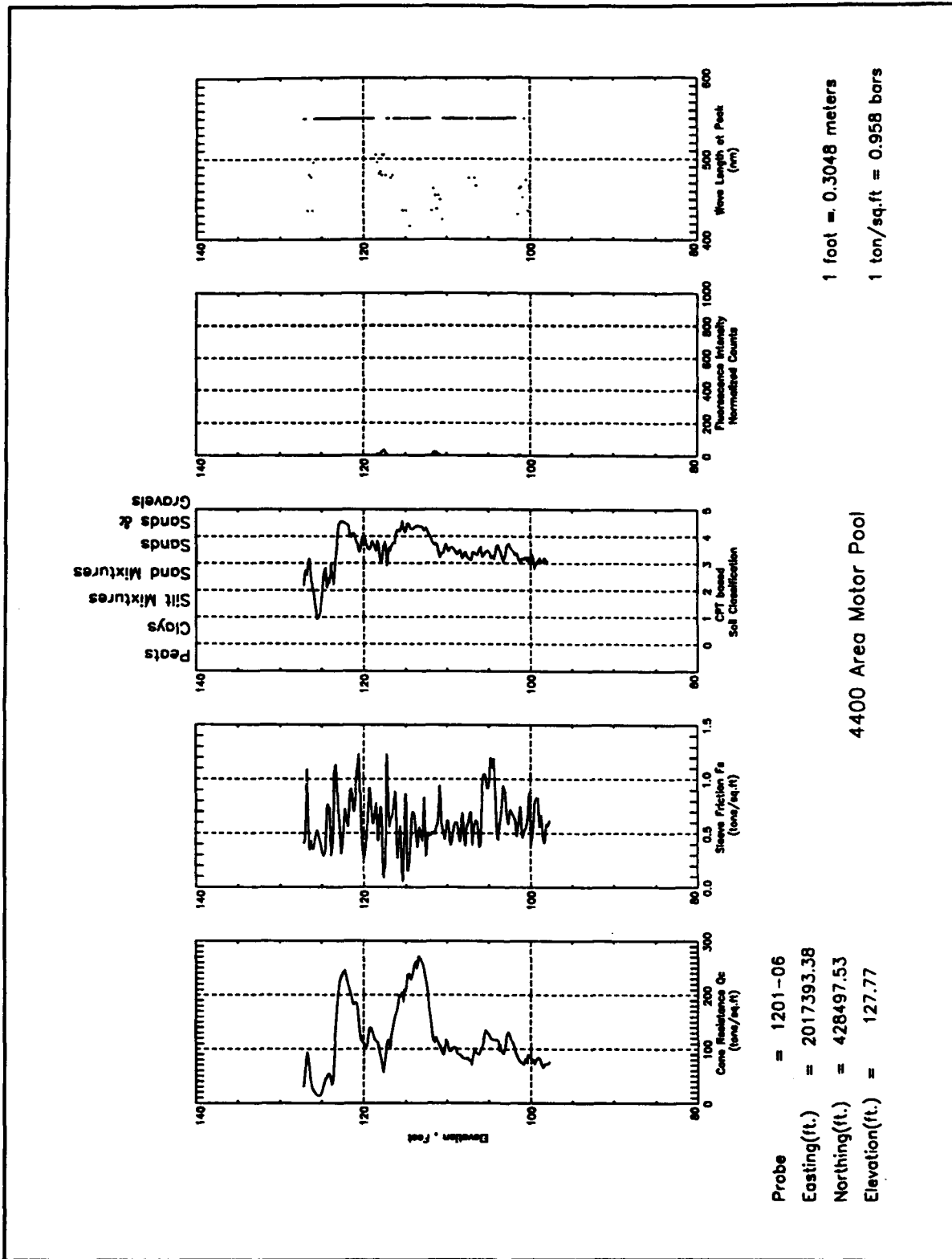

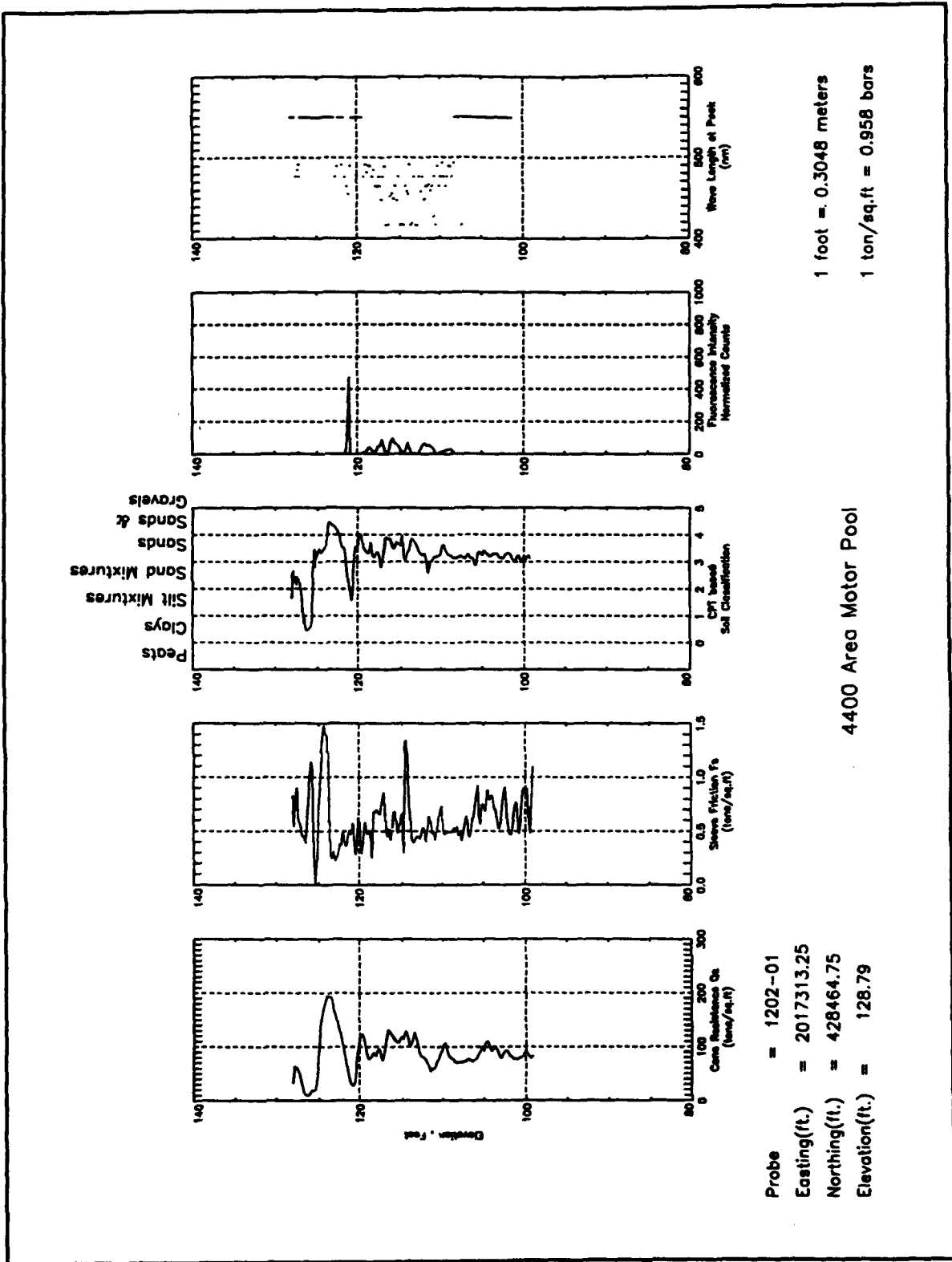

Probe = 1202-01
 Easting(ft.) = 2017313.25
 Northing(ft.) = 428464.75
 Elevation(ft.) = 128.79

1 foot = 0.3048 meters
 1 ton/sq.ft = 0.958 bars

4400 Area Motor Pool

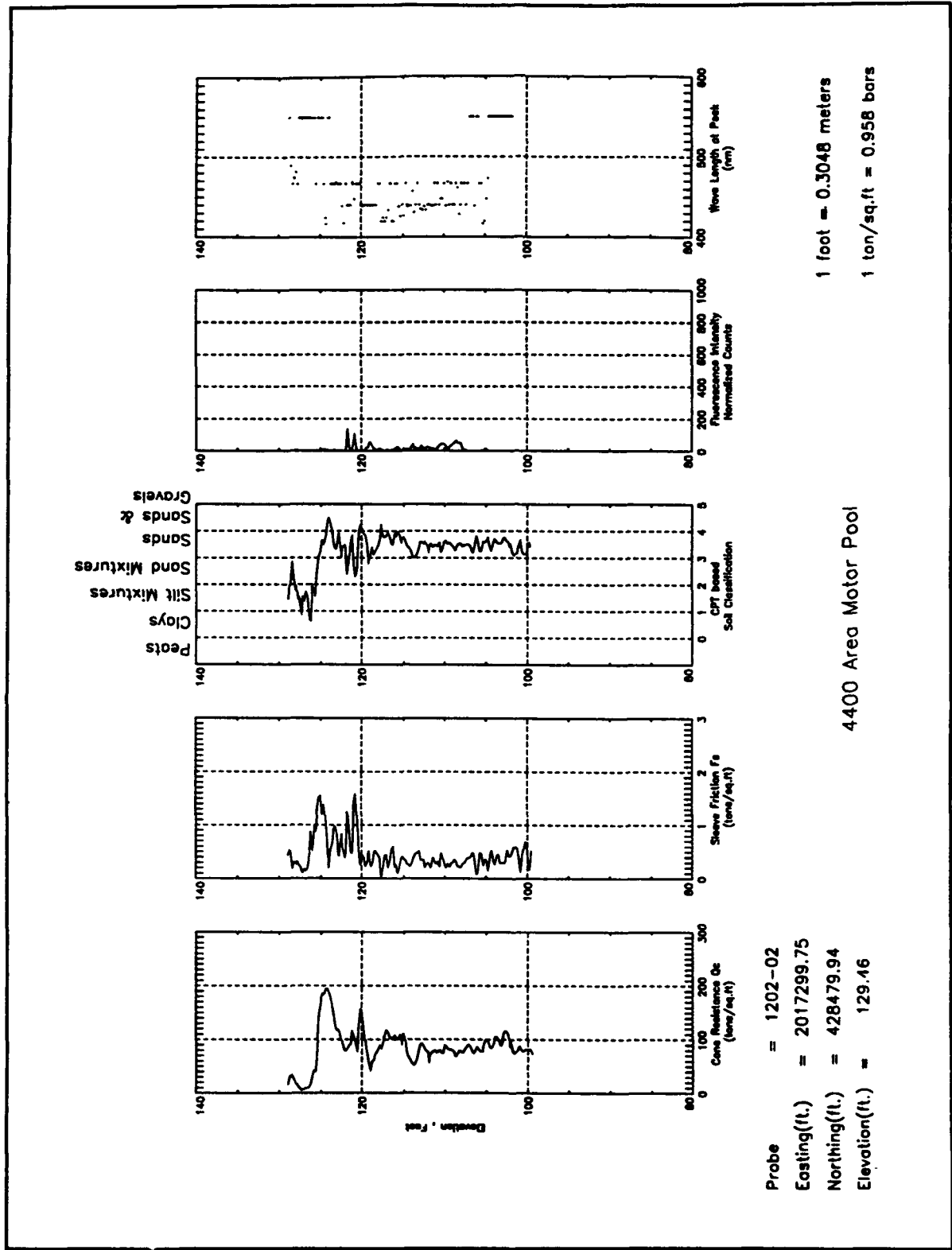

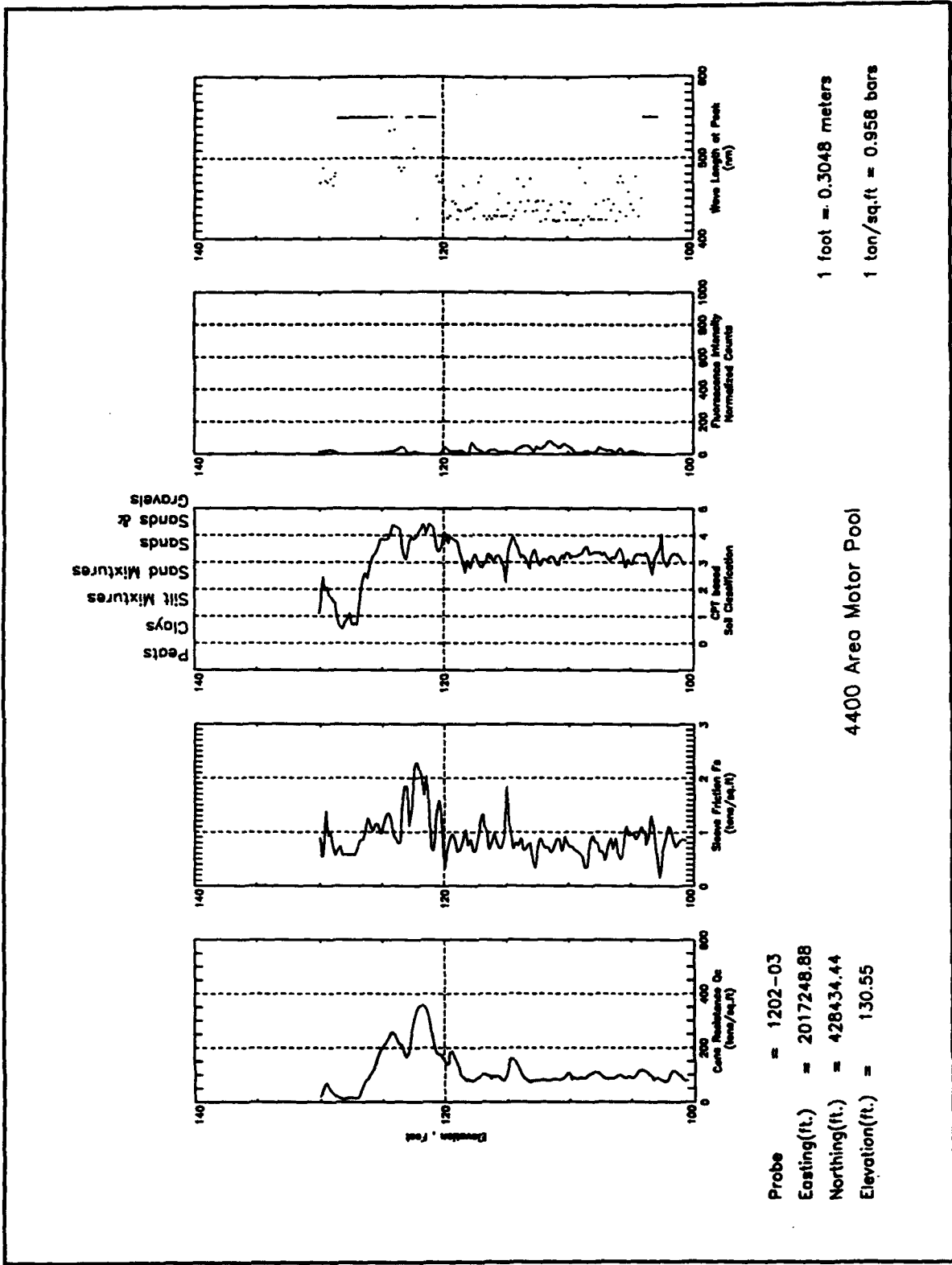

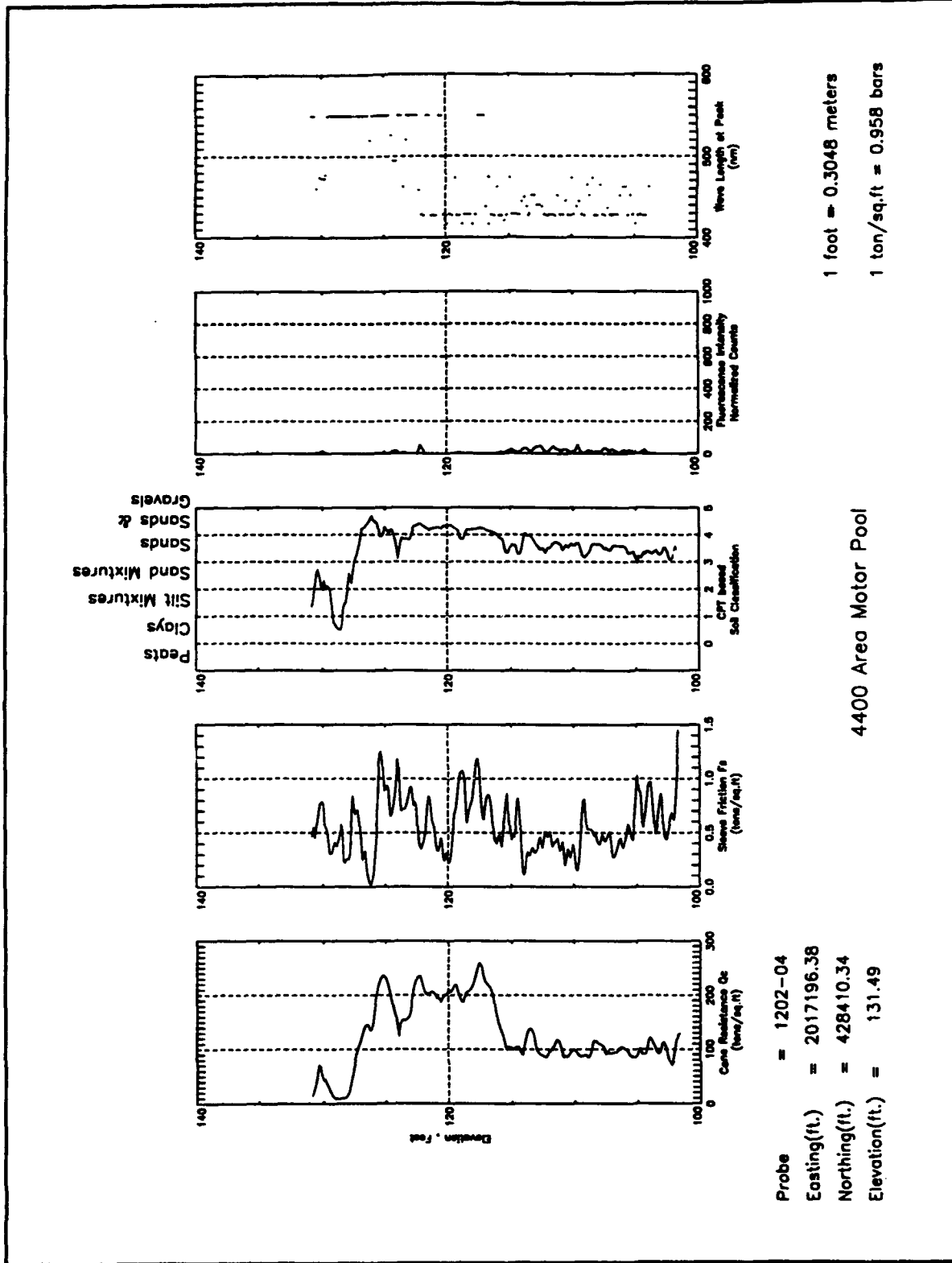

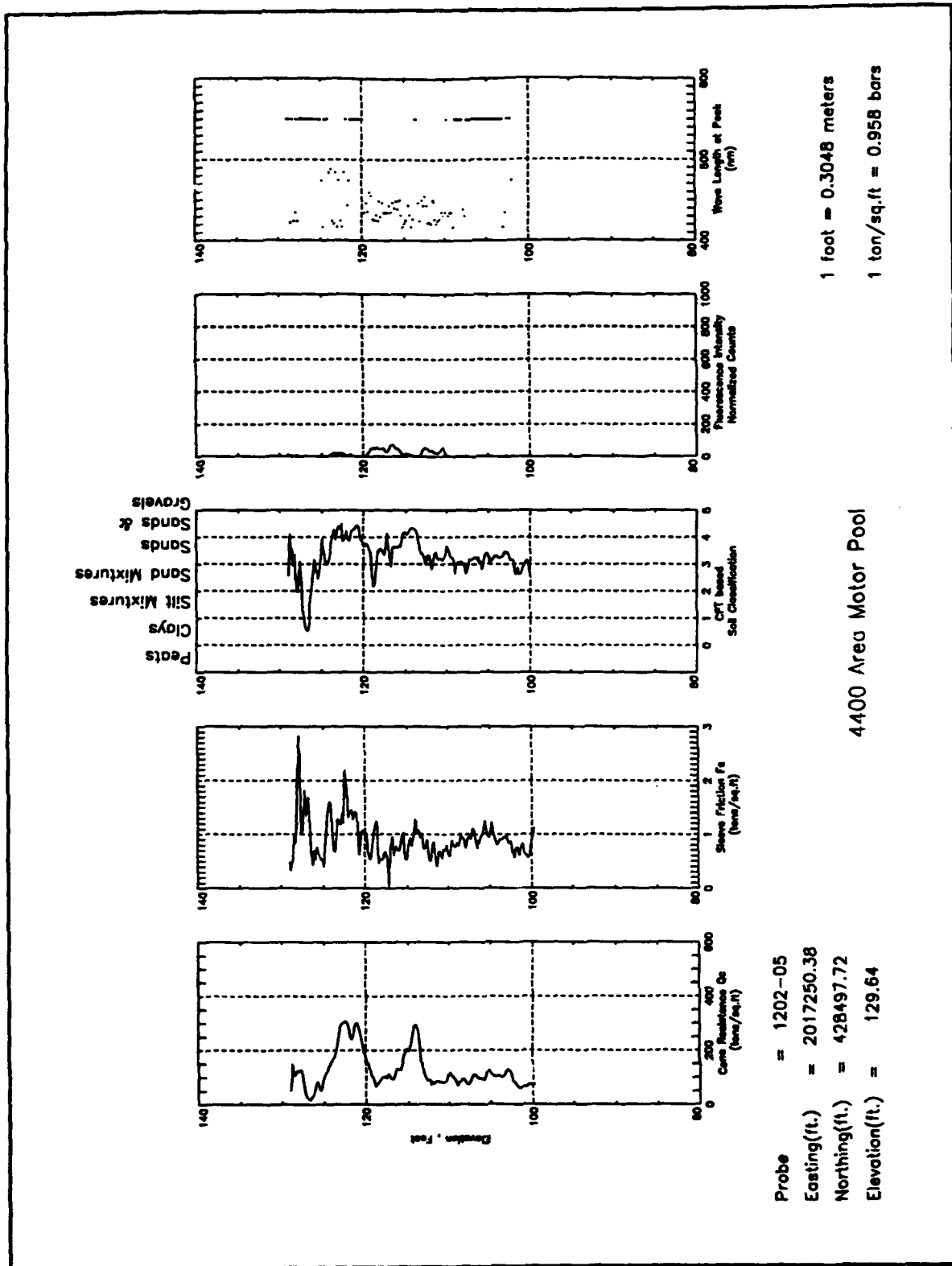

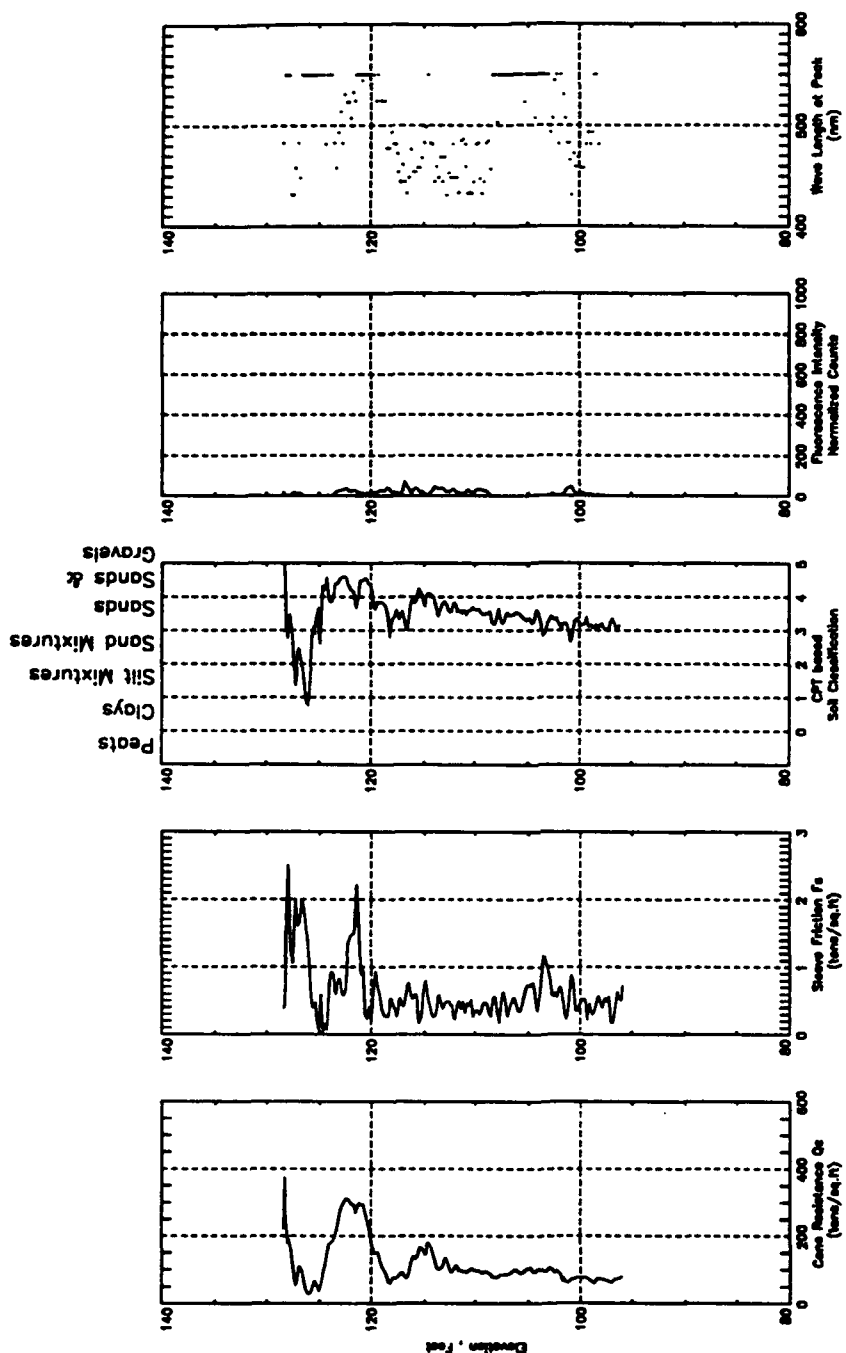

Probe = 1202-06
 Easting(ft.) = 2017292.63
 Northing(ft.) = 428520.91
 Elevation(ft.) = 129.09

4400 Area Motor Pool

1 foot = 0.3048 meters
 1 ton/sq.ft = 0.958 bars

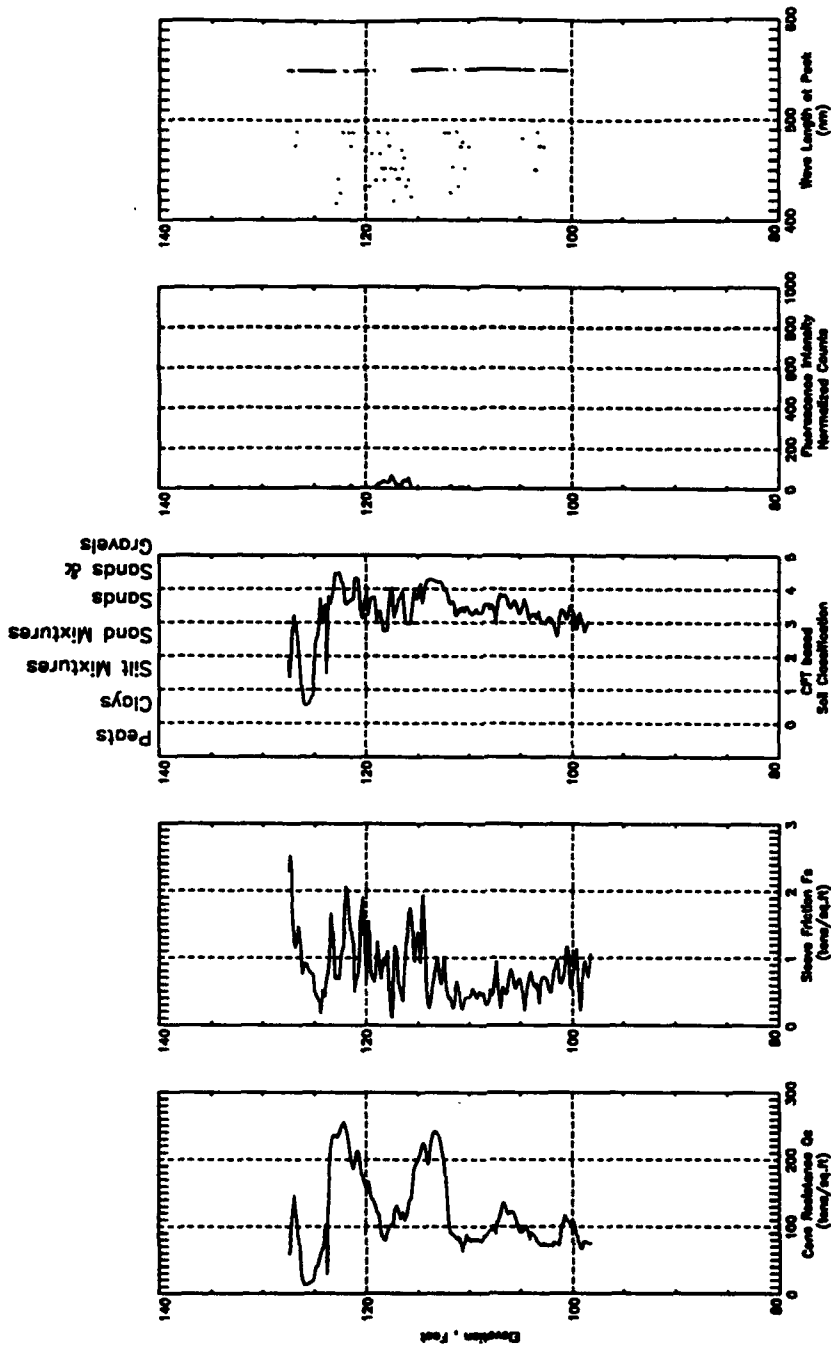

Probe = 1203-01
 Easting(ft.) = 2017336.88
 Northing(ft.) = 428584.34
 Elevation(ft.) = 128.14

1 foot = 0.3048 meters
 1 ton/sq.ft = 0.958 bars

4400 Area Motor Pool

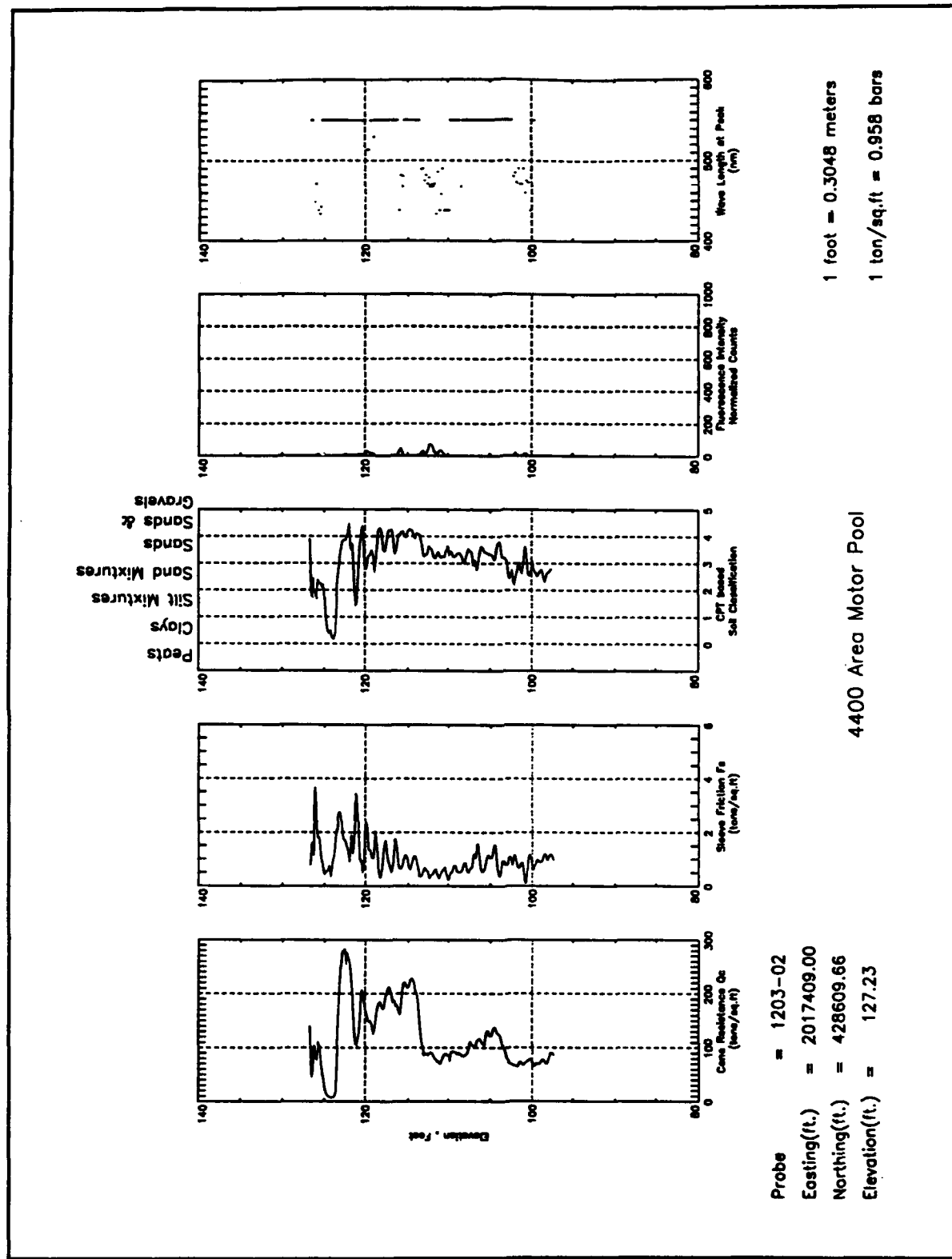

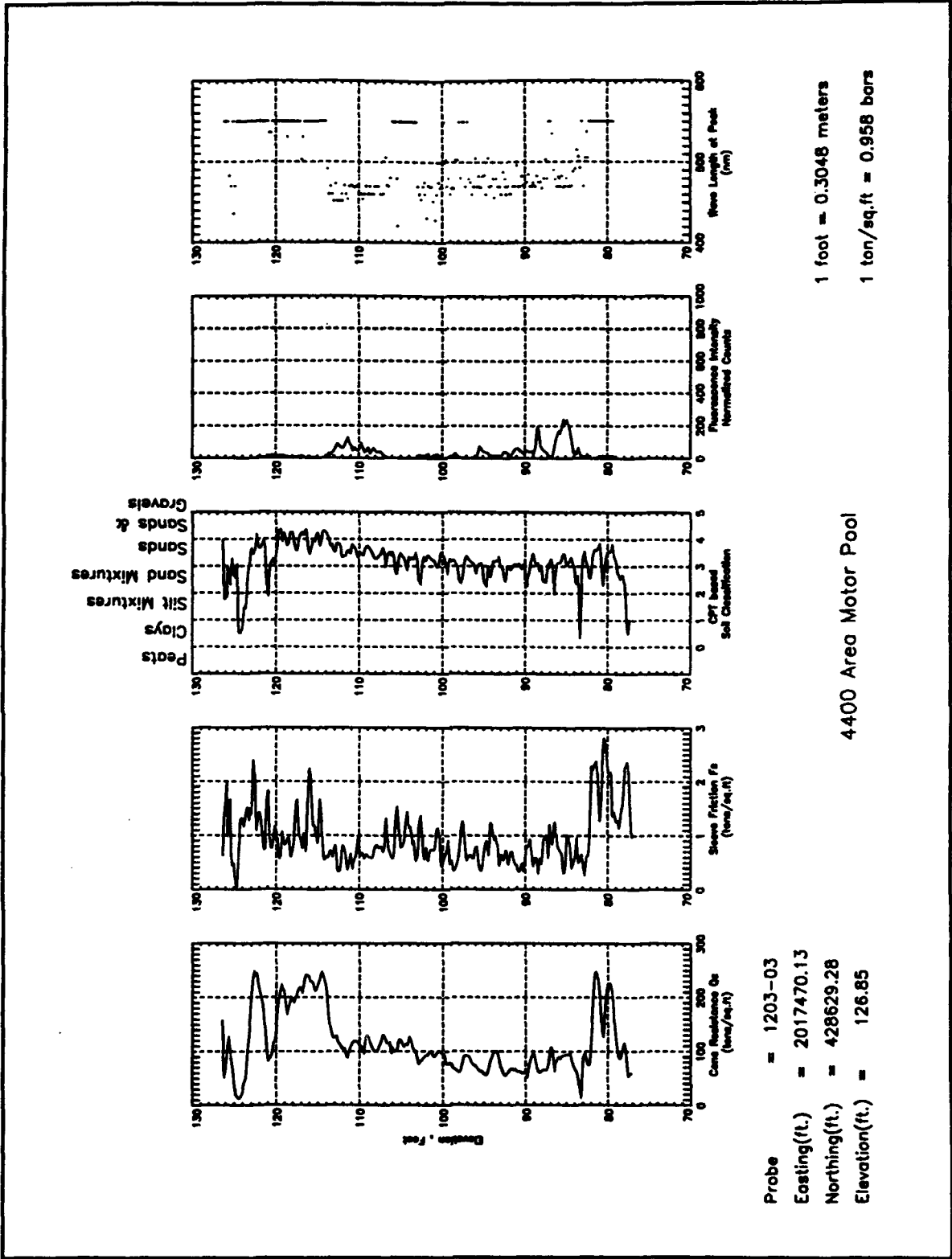

Probe = 1203-03
 Easting(ft.) = 2017470.13
 Northing(ft.) = 428629.28
 Elevation(ft.) = 126.85

1 foot = 0.3048 meters
 1 ton/sq.ft = 0.958 bars

4400 Area Motor Pool

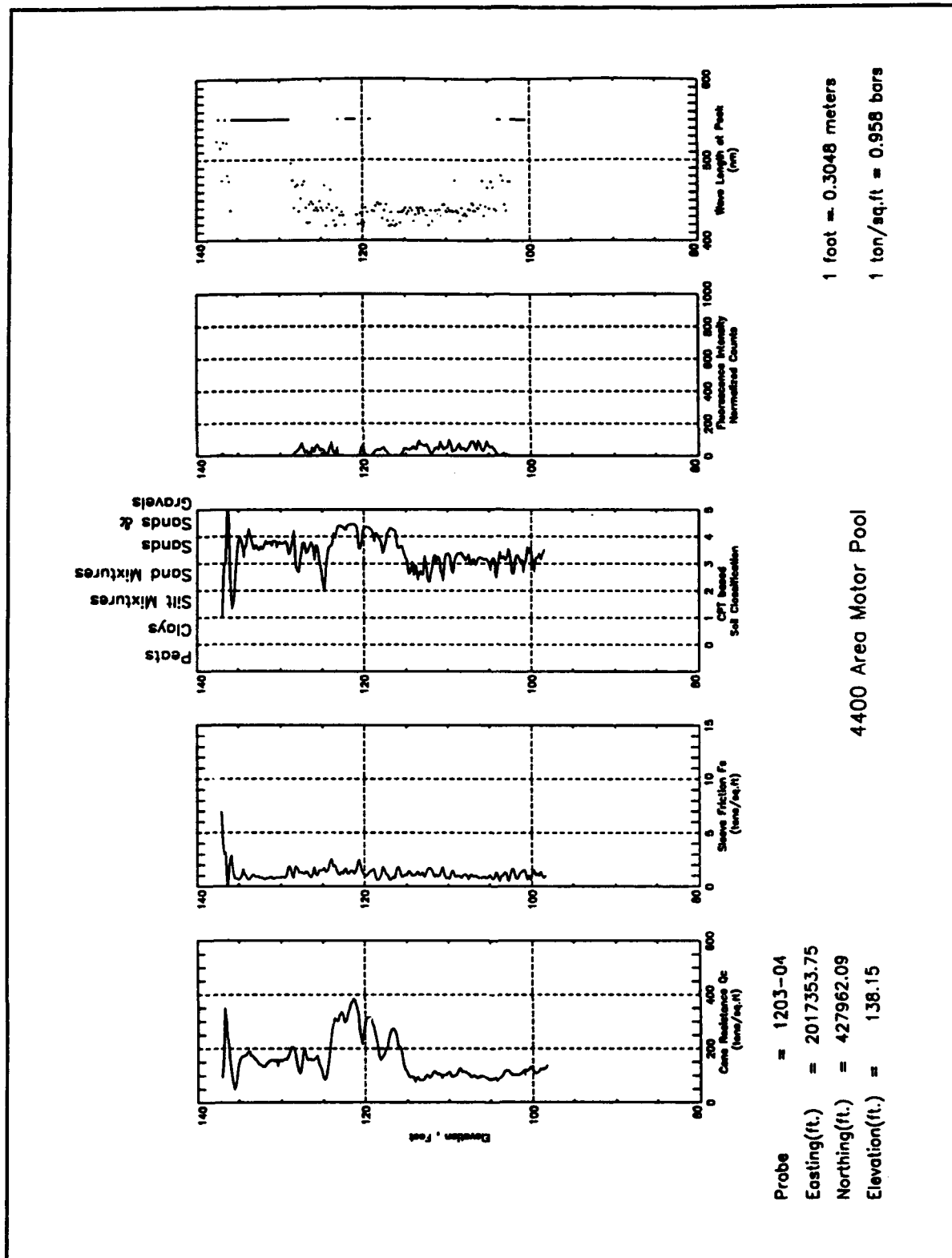

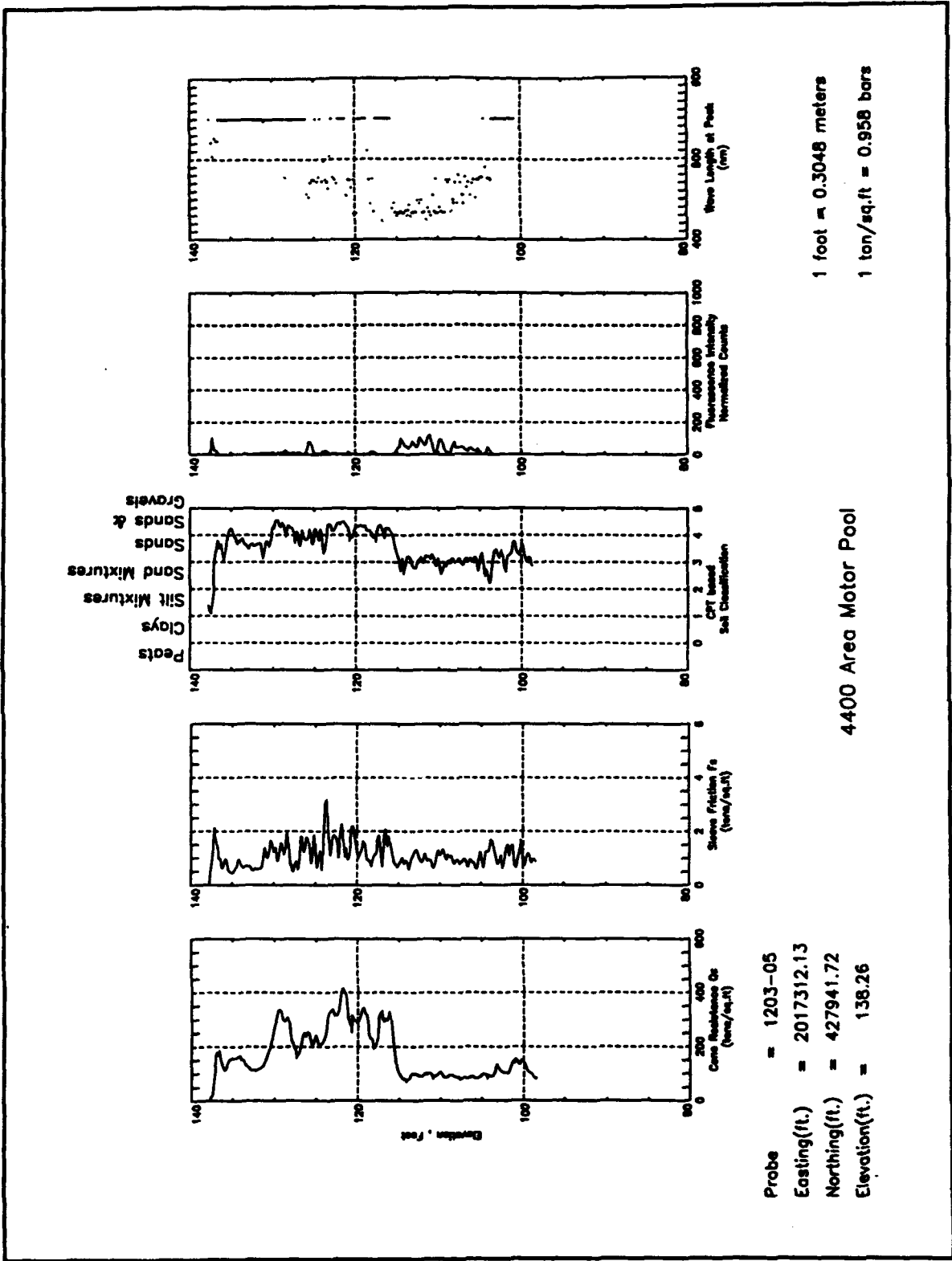

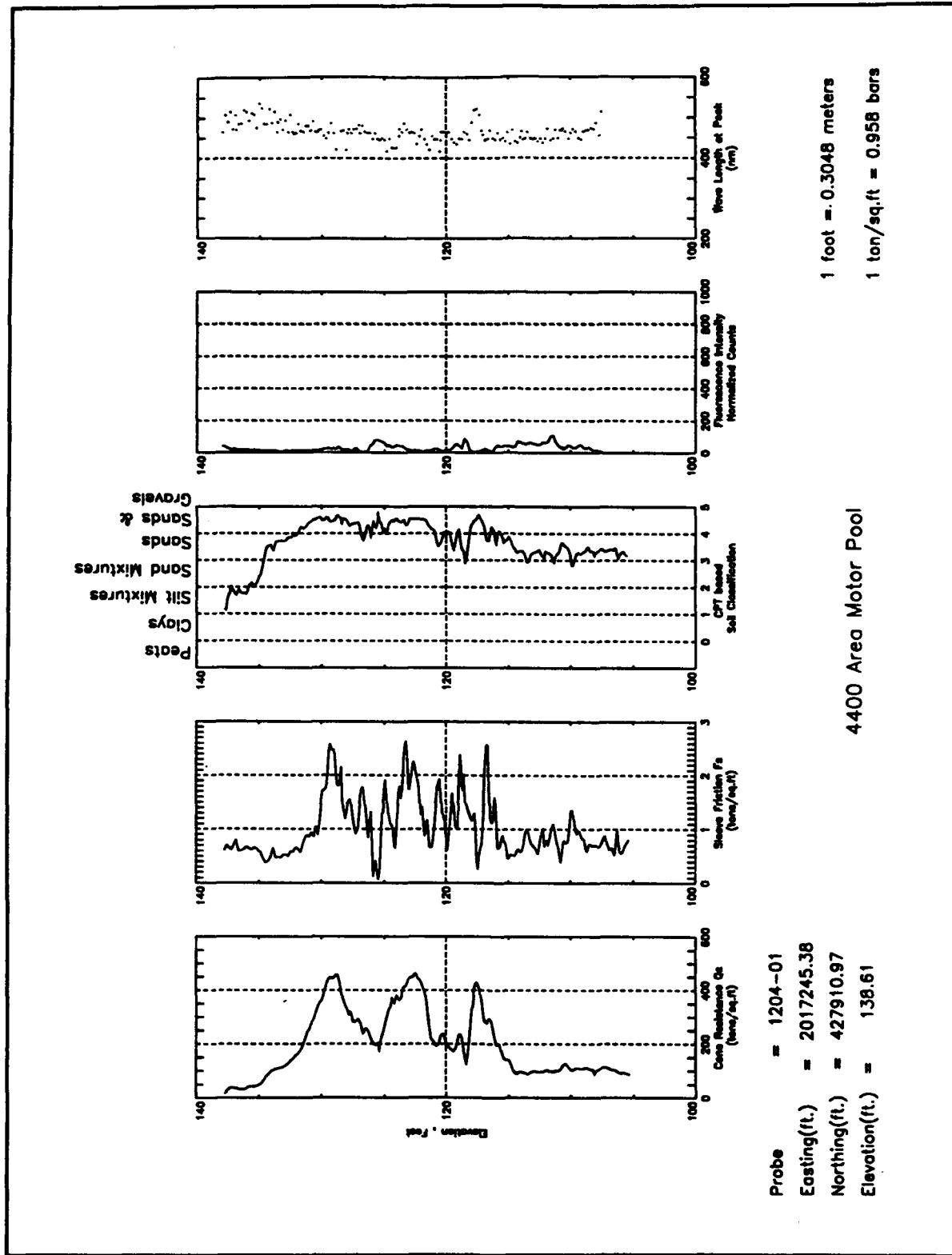

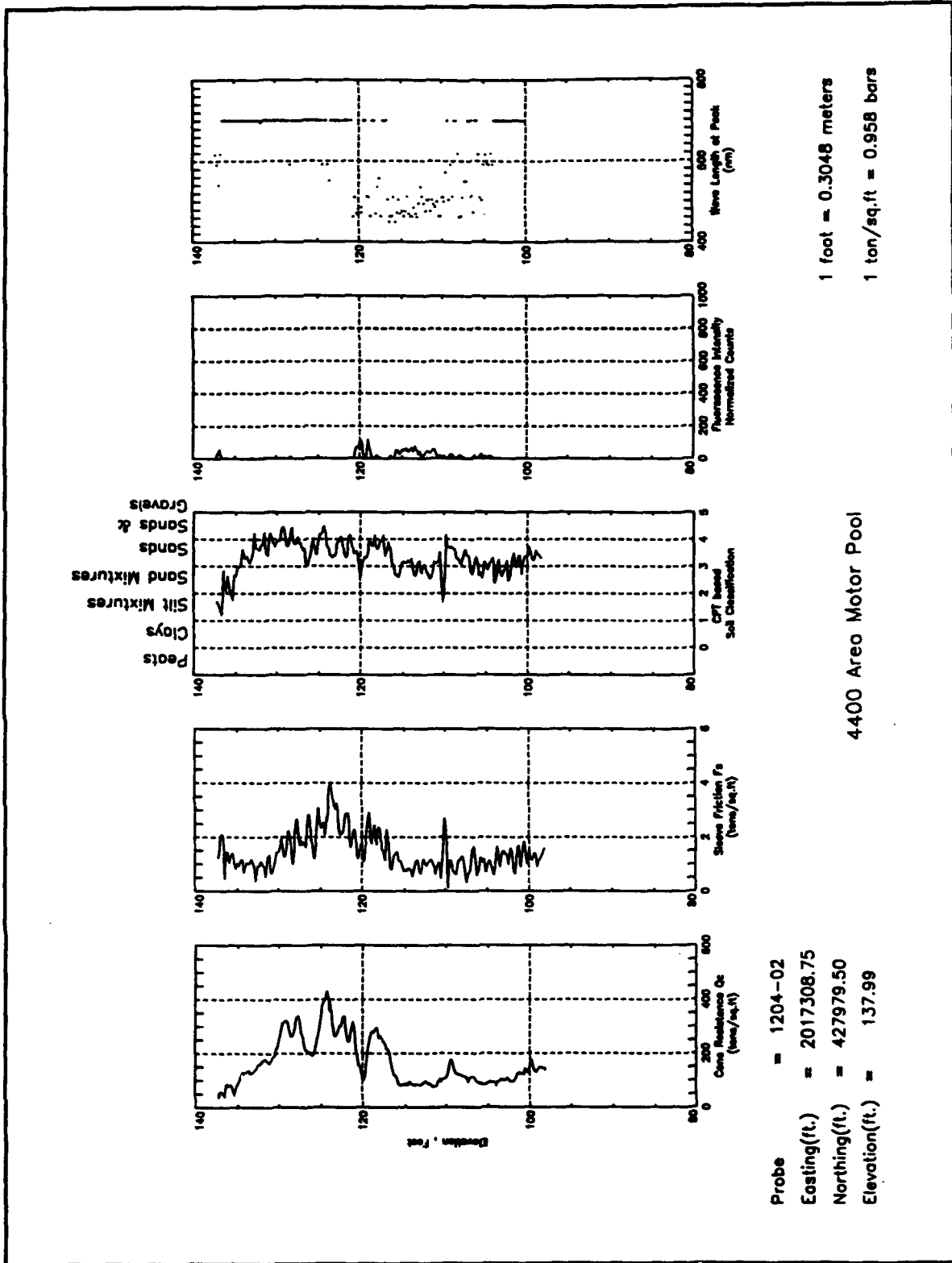

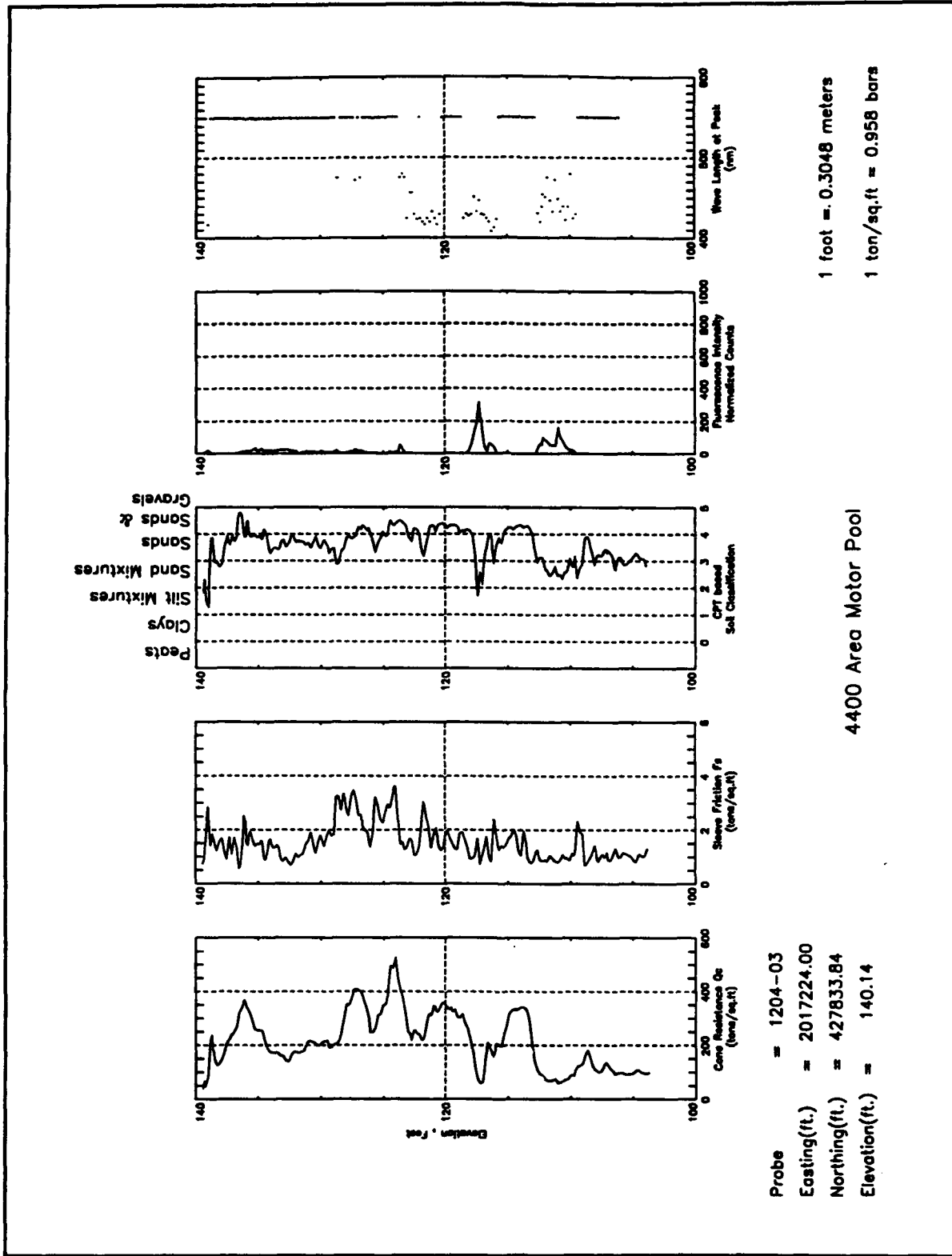

1 foot = 0.3048 meters
 1 ton/sq.ft = 0.958 bars

4400 Area Motor Pool

Probe = 1204-03
 Easting(ft.) = 2017224.00
 Northing(ft.) = 427833.84
 Elevation(ft.) = 140.14

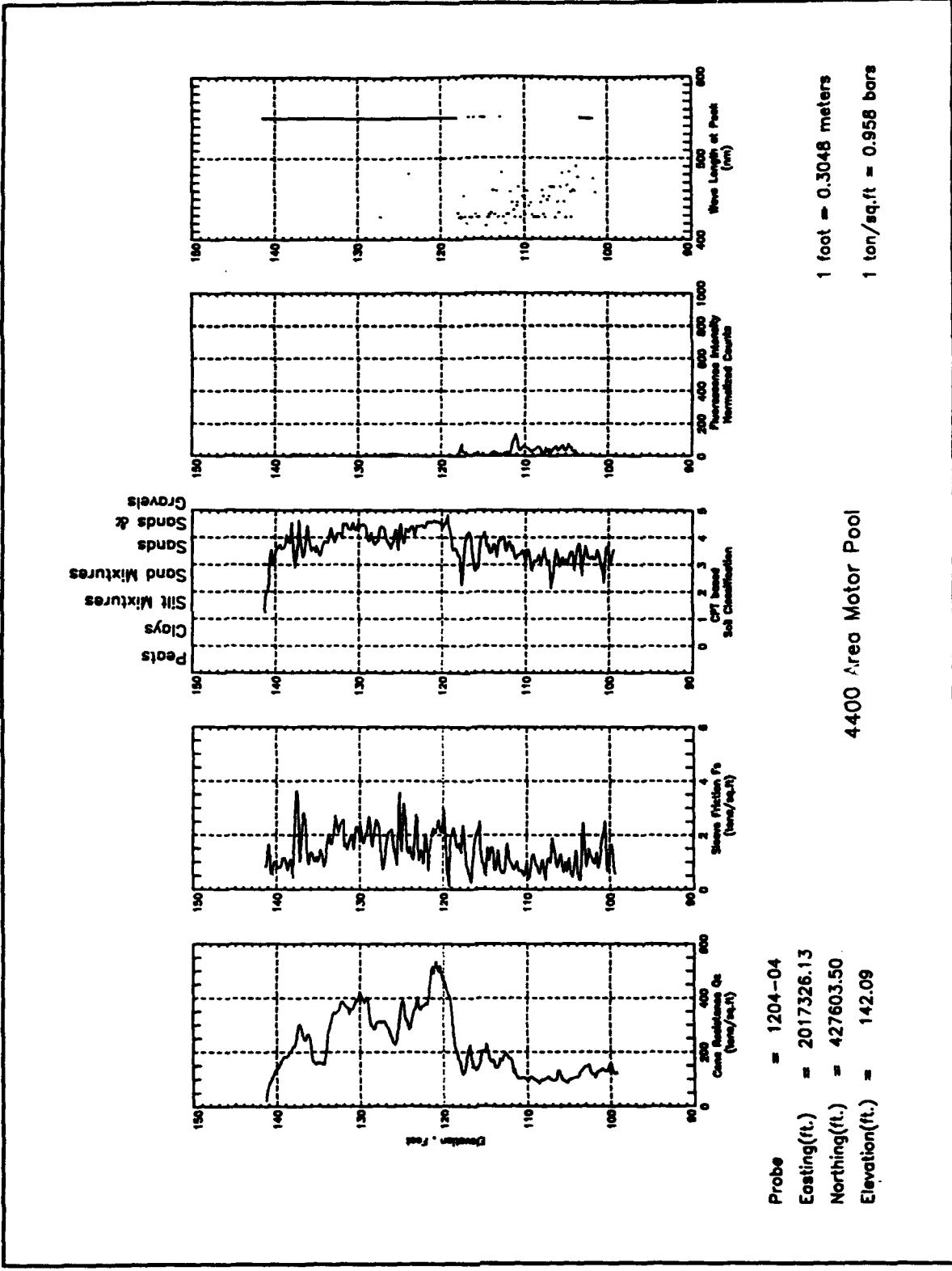

Probe = 1204-04
 Easting(ft.) = 2017326.13
 Northing(ft.) = 427603.50
 Elevation(ft.) = 142.09

1 foot = 0.3048 meters
 1 ton/sq.ft = 0.958 bars

4400 Area Motor Pool

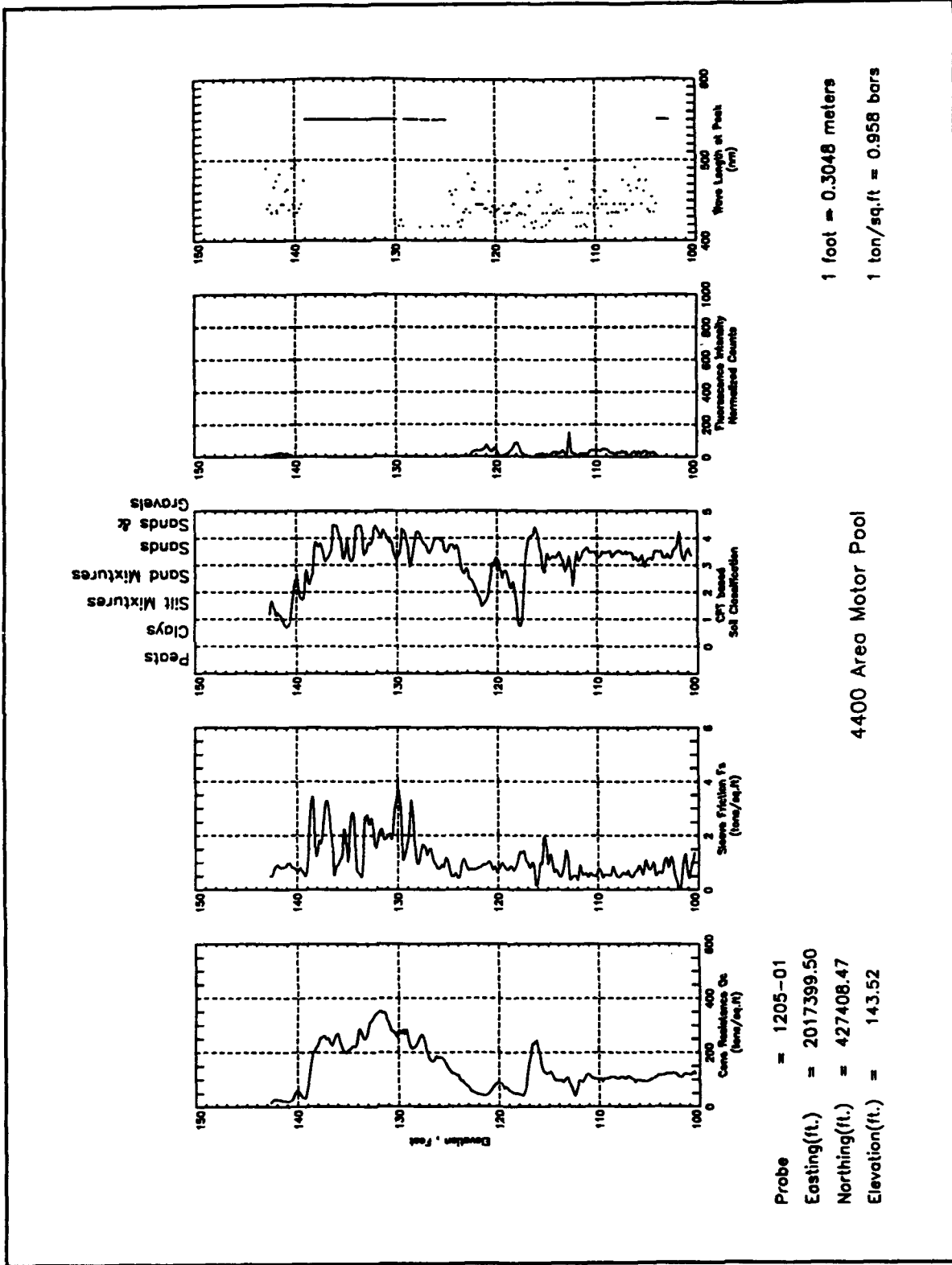

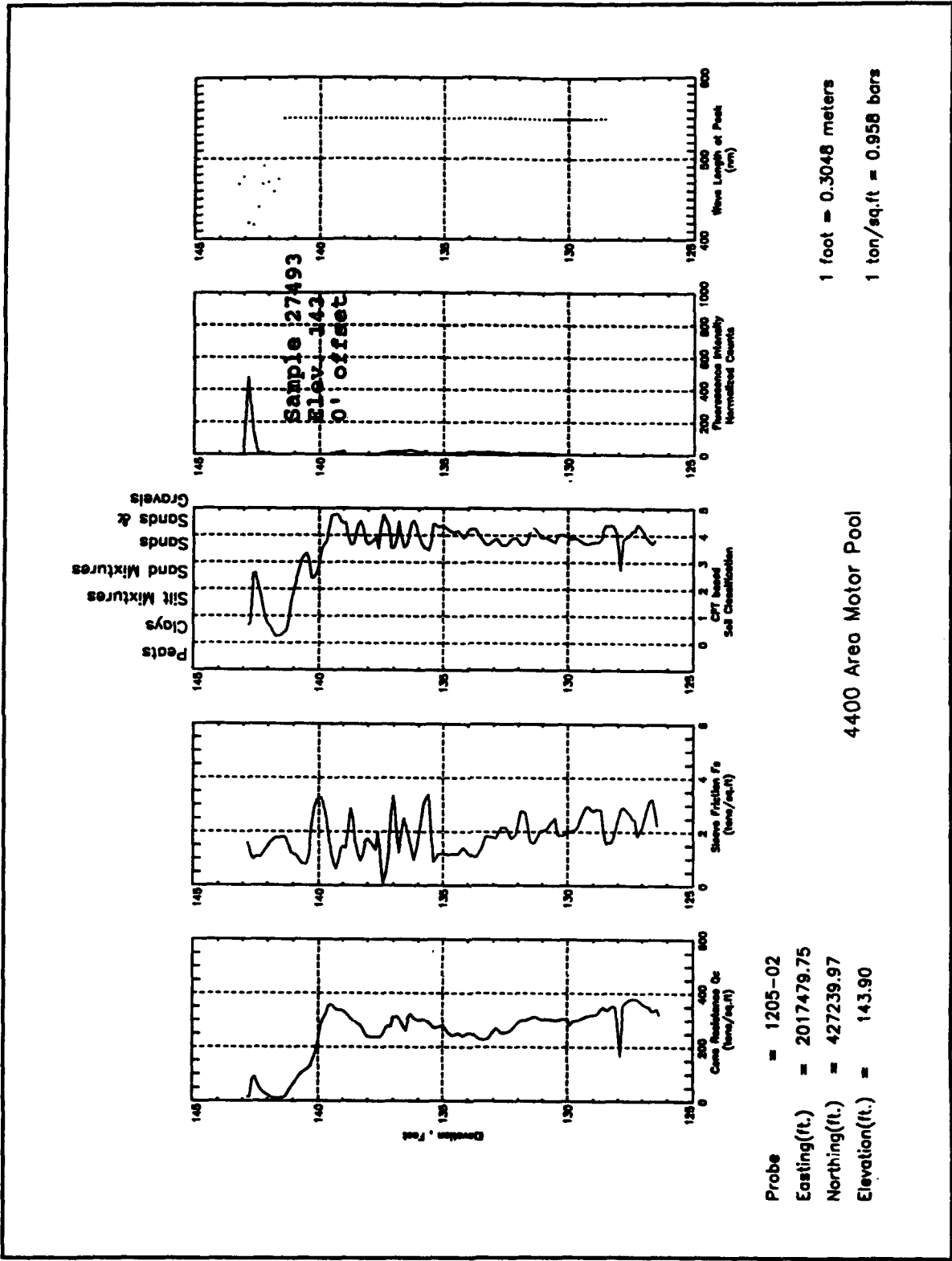

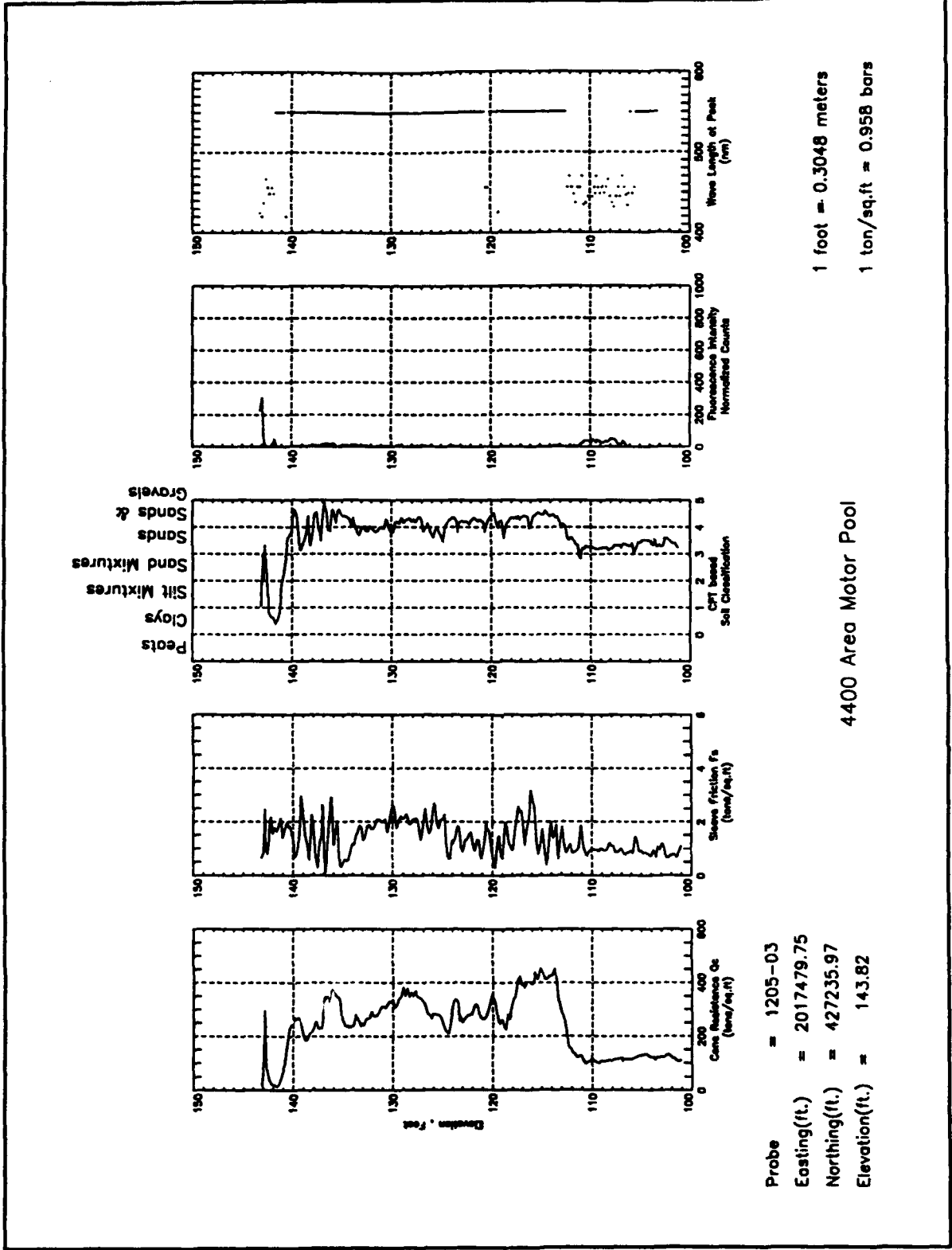

Probe = 1205-03
 Easting(ft.) = 2017479.75
 Northing(ft.) = 427235.97
 Elevation(ft.) = 143.82

4400 Area Motor Pool

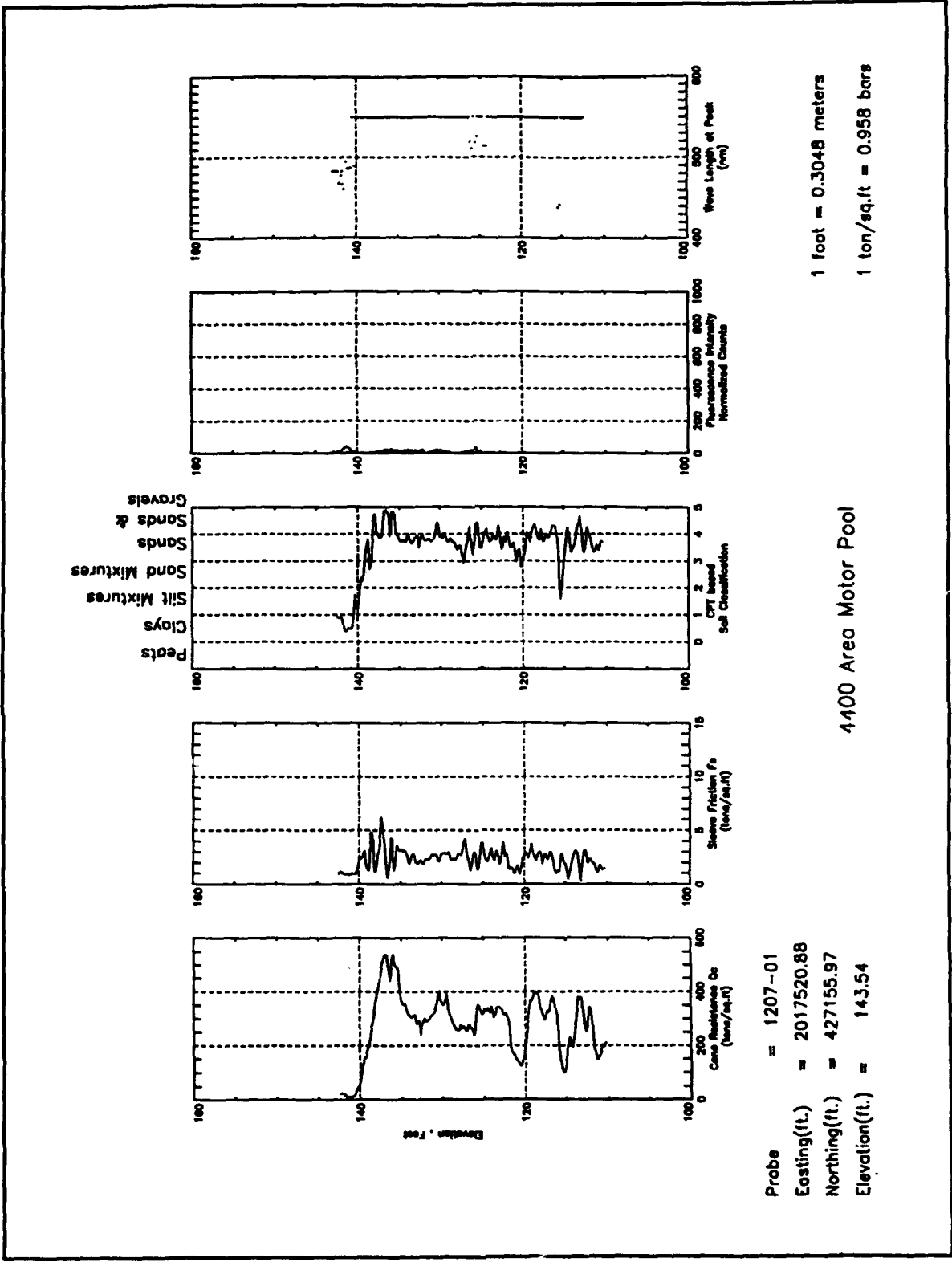

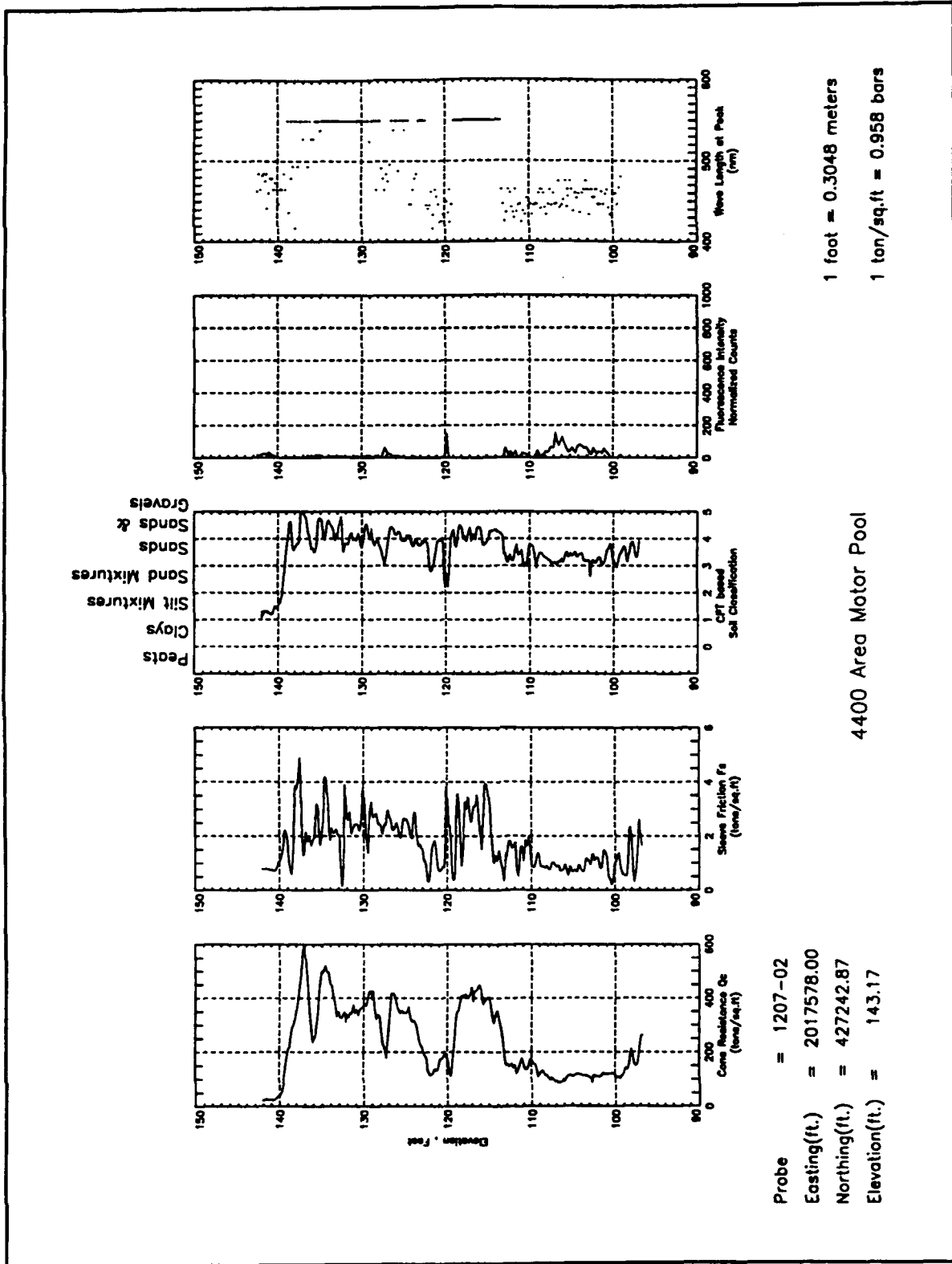

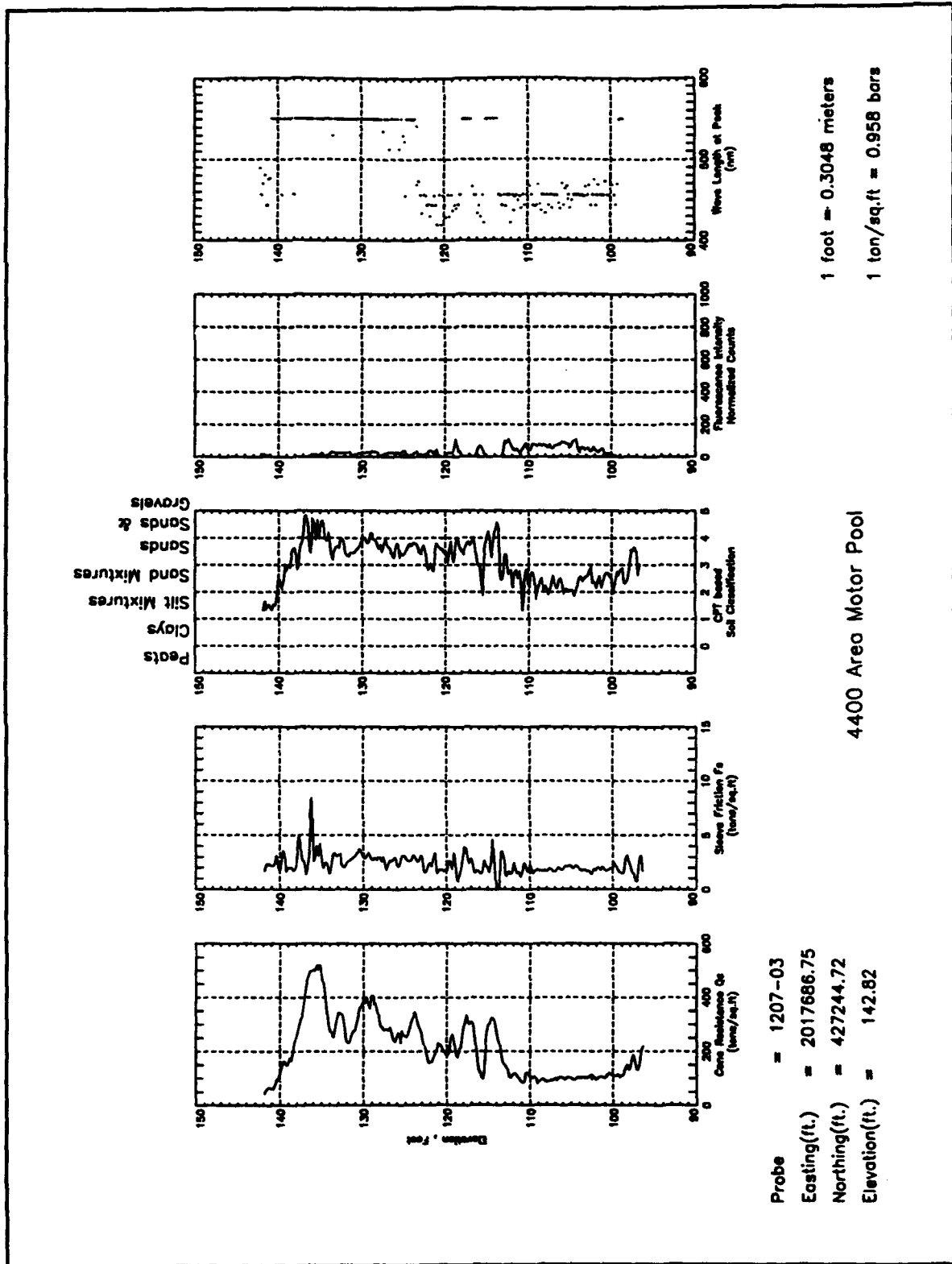

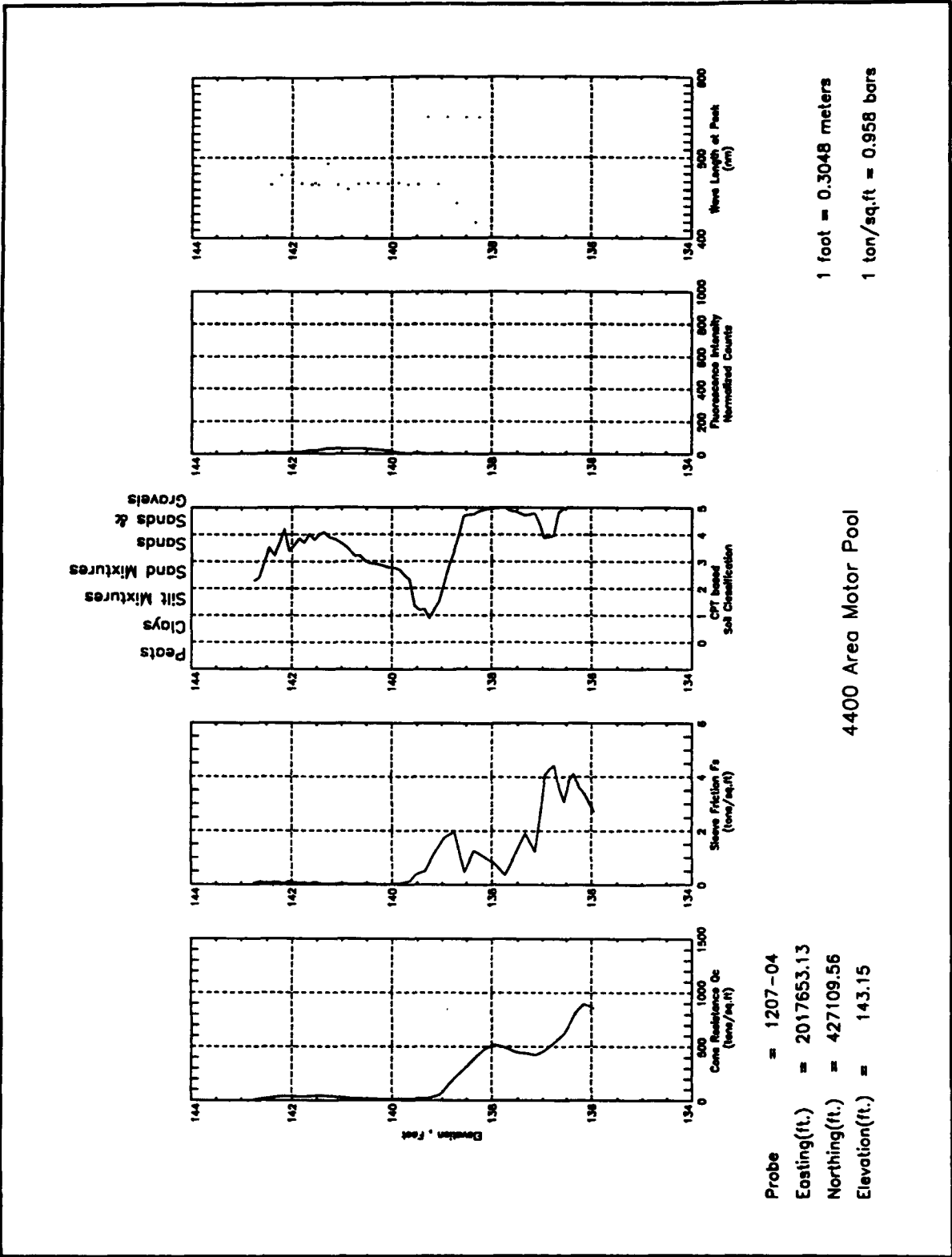

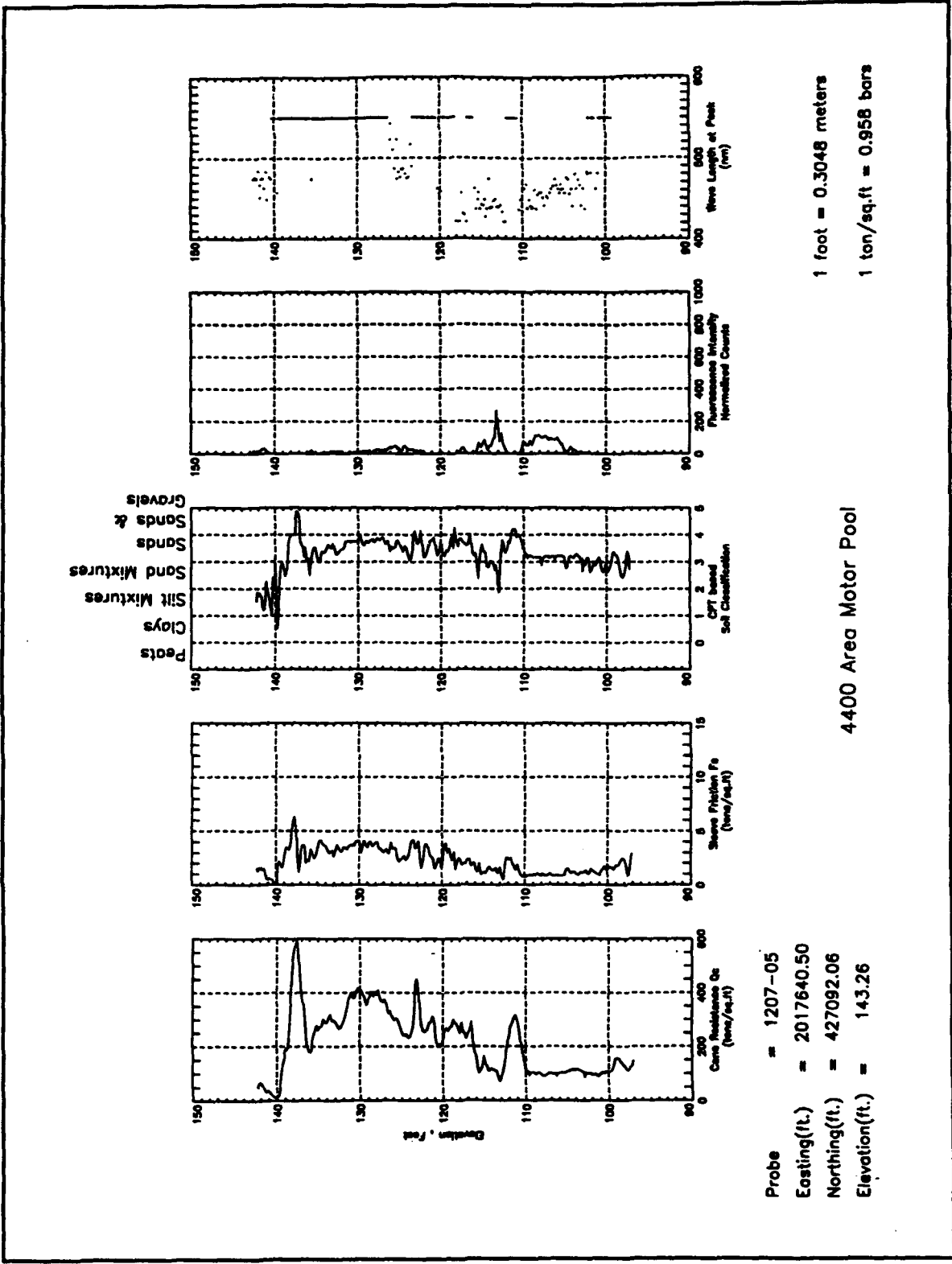

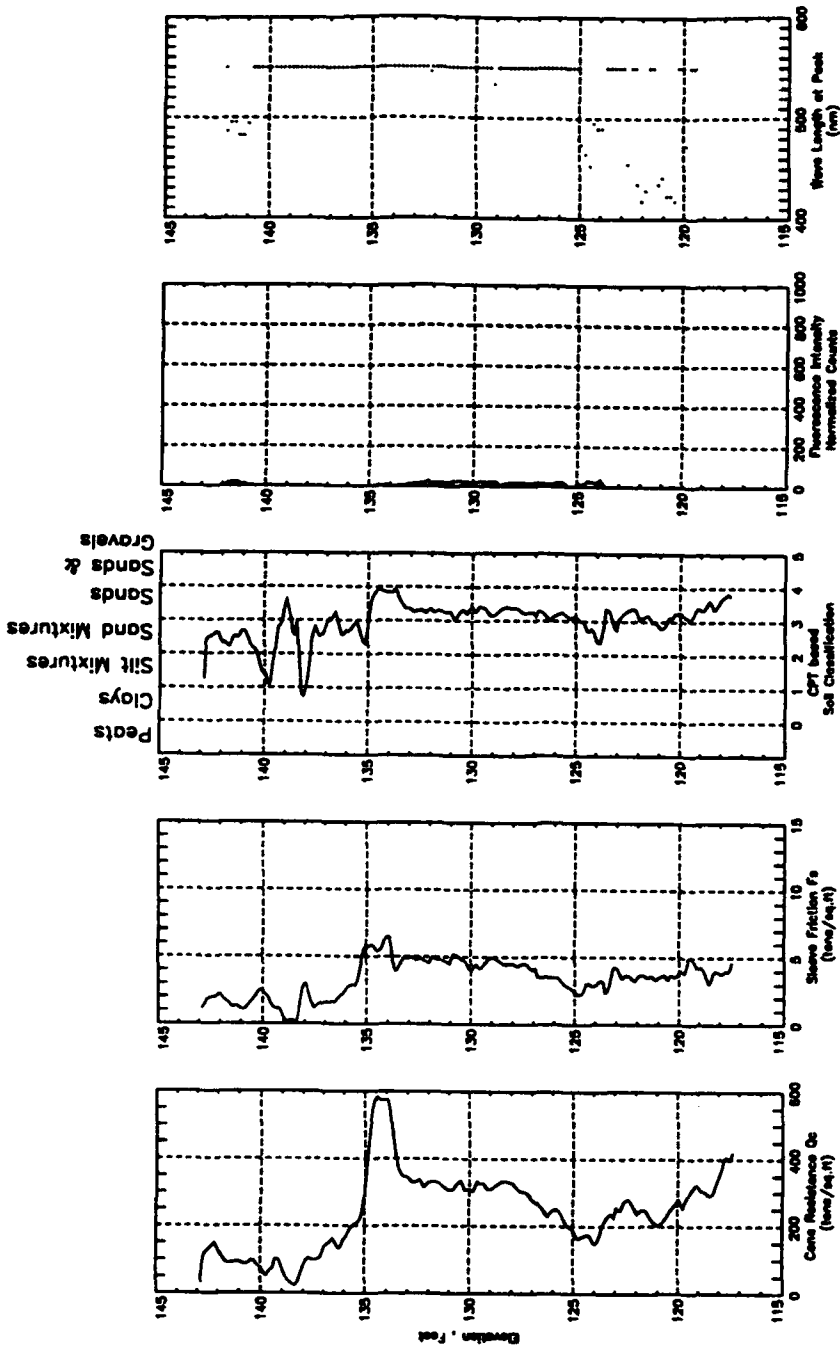

Probe = 1207-06
 Easting(ft.) = 2017591.00
 Northing(ft.) = 426987.22
 Elevation(ft.) = 143.84

4400 Area Motor Pool

1 foot = 0.3048 meters

1 ton/sq.ft = 0.958 bars

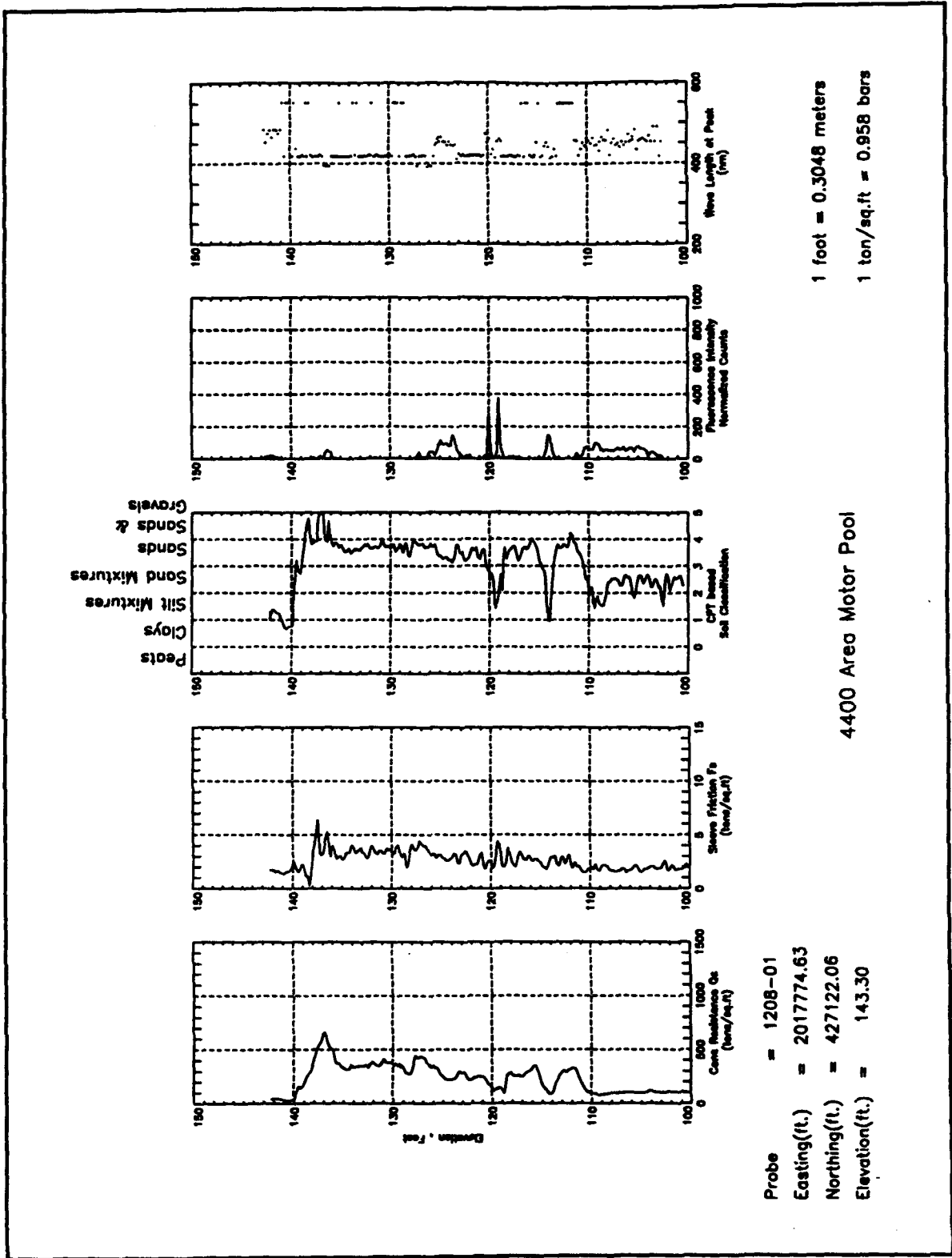

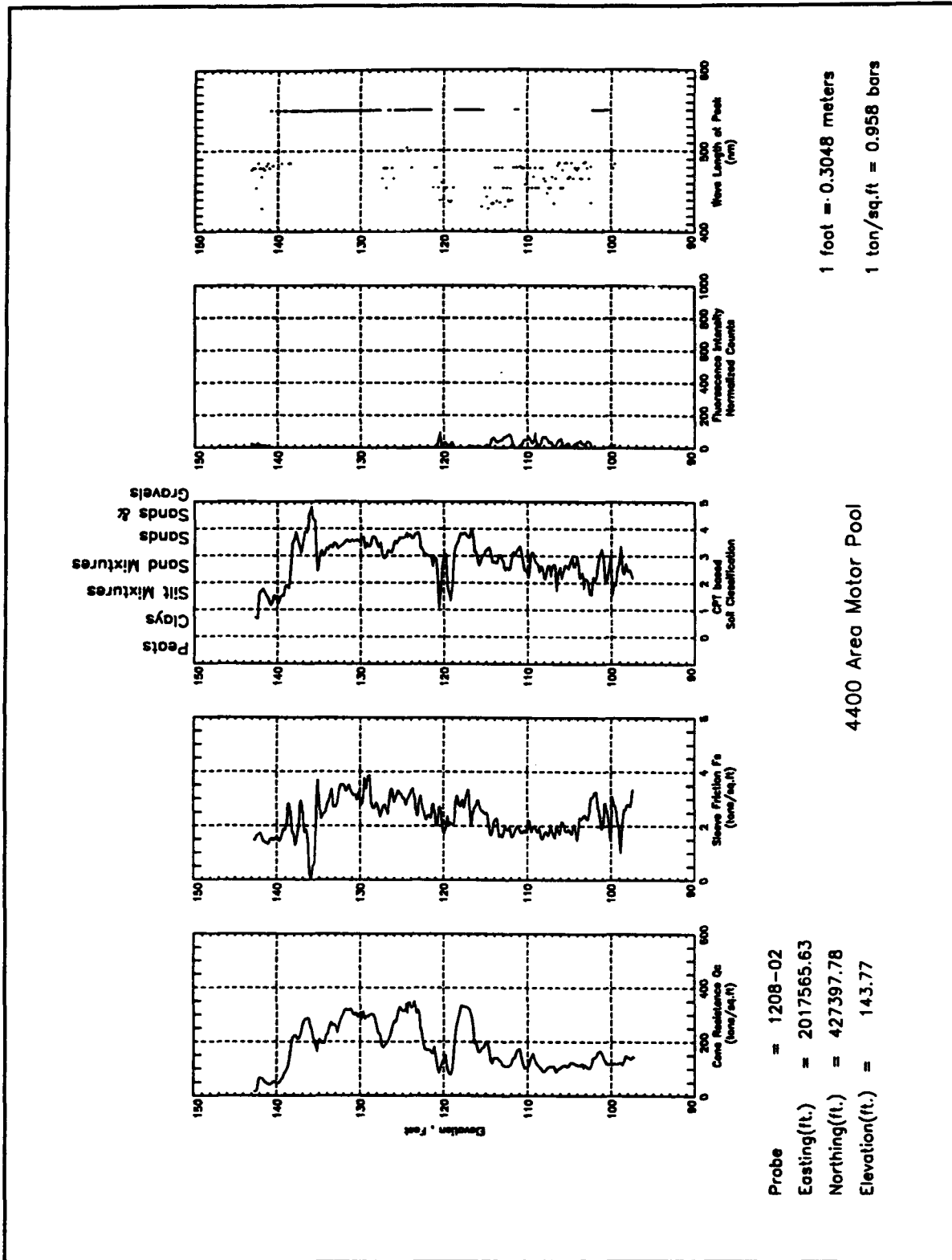

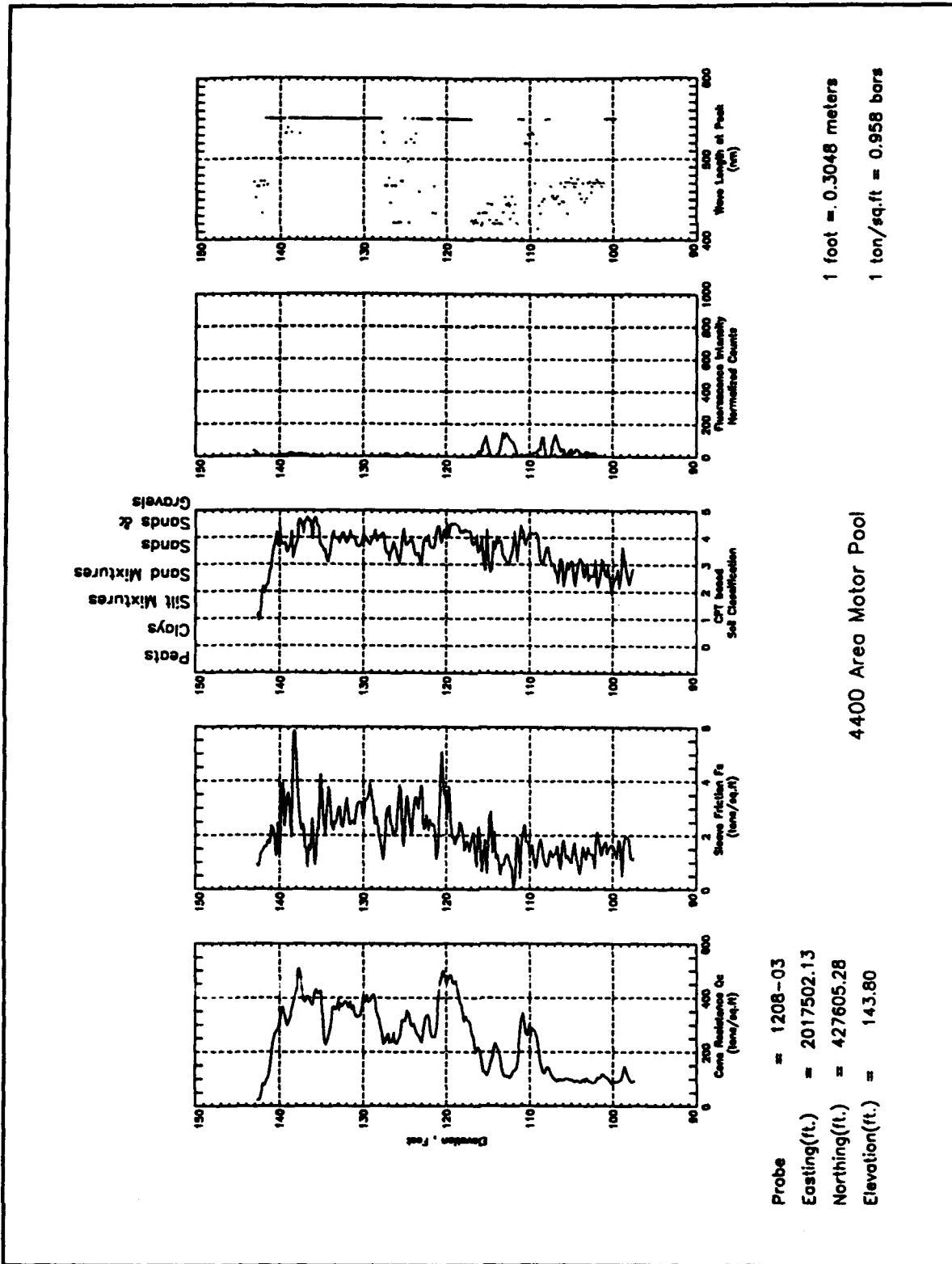

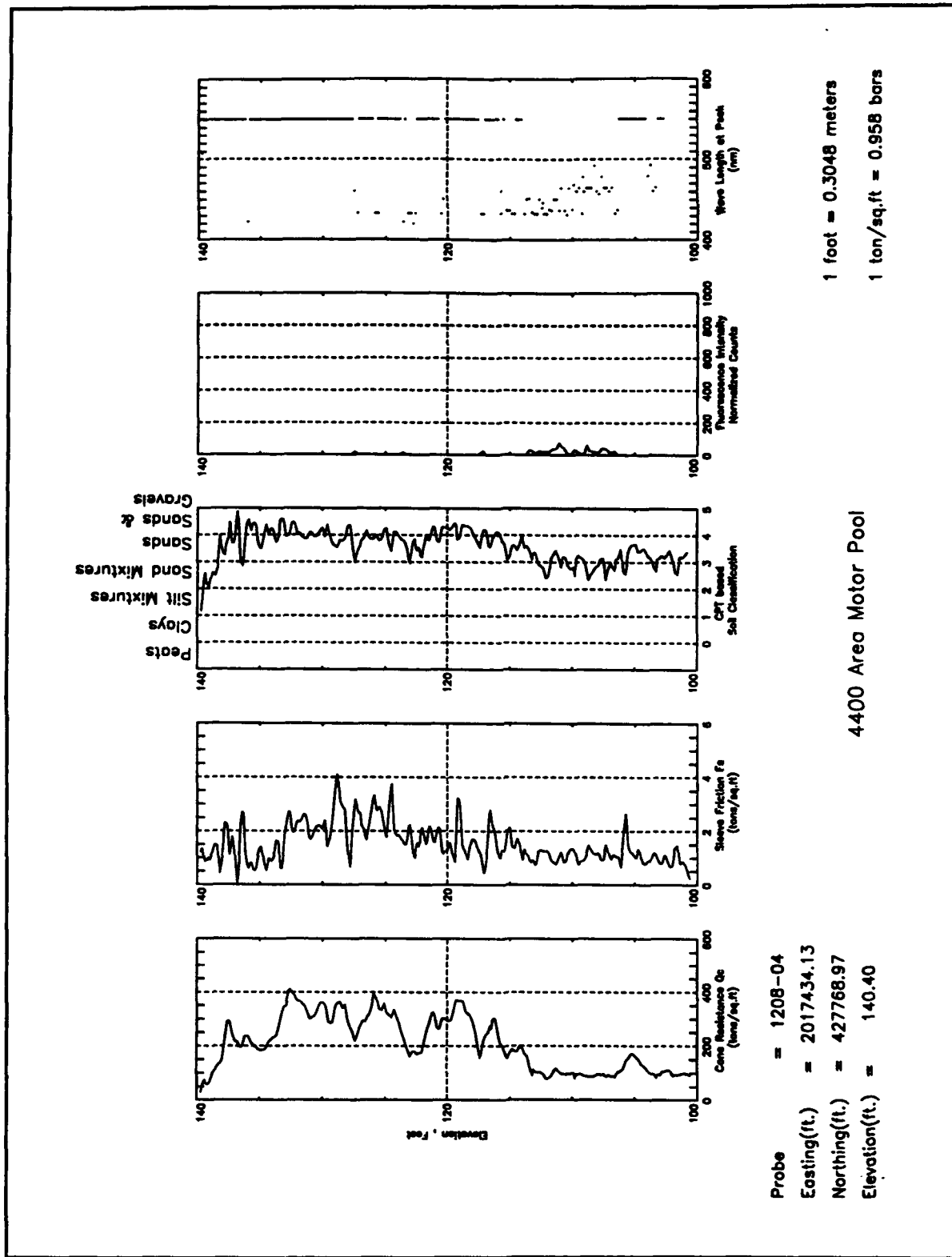

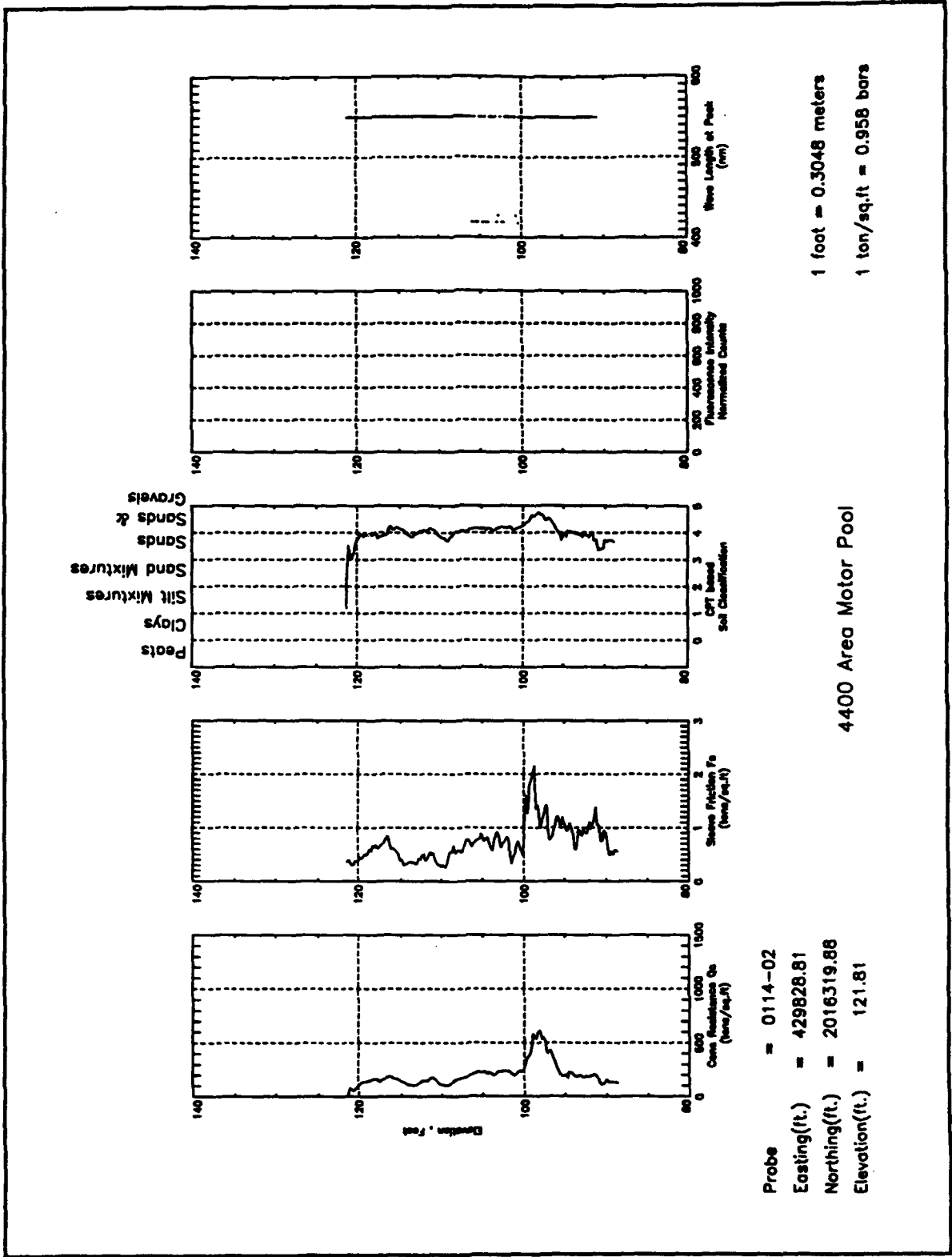

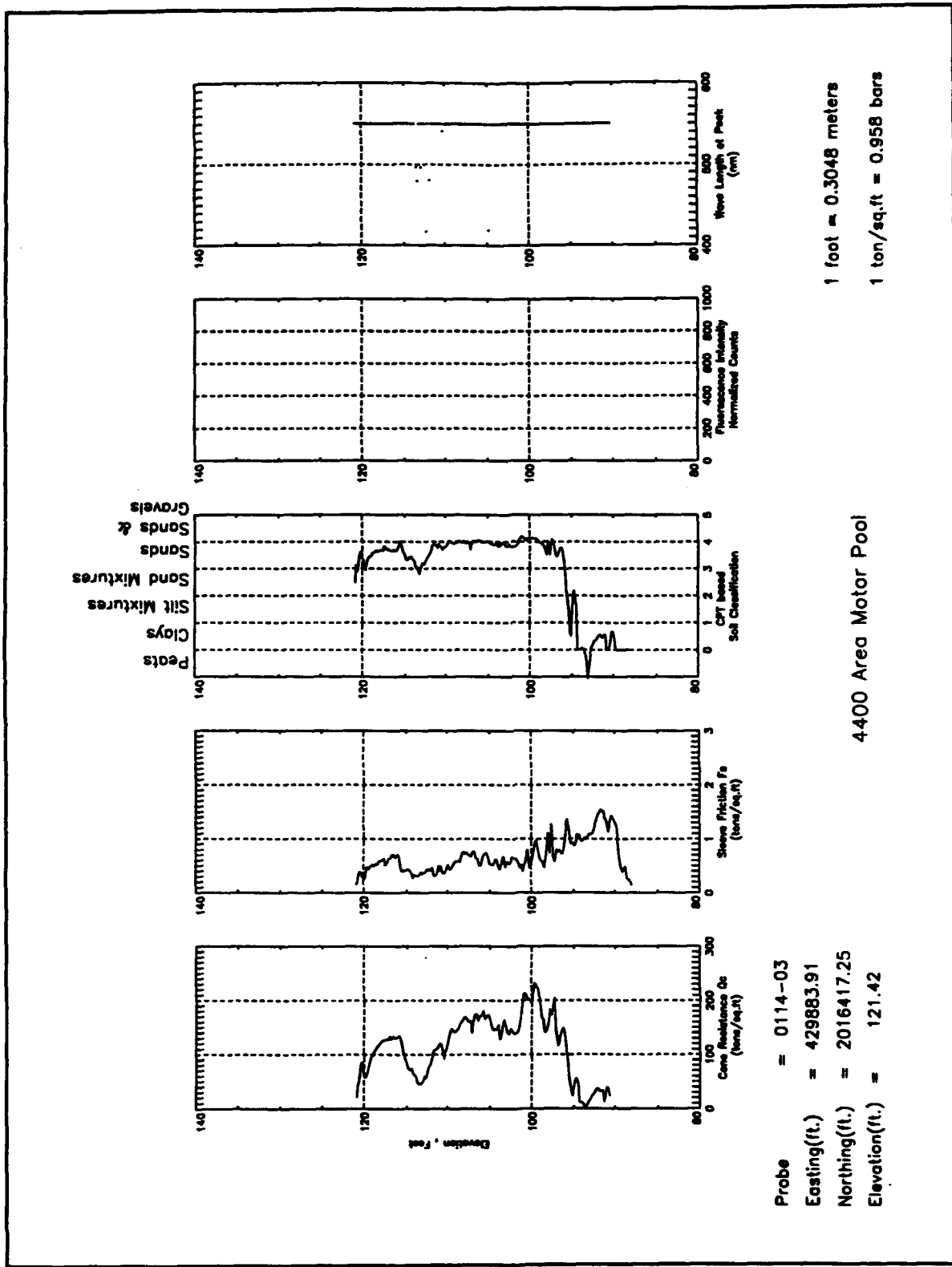

Probe = 0114-03
 Easting(ft.) = 429883.91
 Northing(ft.) = 2016417.25
 Elevation(ft.) = 121.42

1 foot = 0.3048 meters
 1 ton/sq.ft = 0.958 bars
 4400 Area Motor Pool

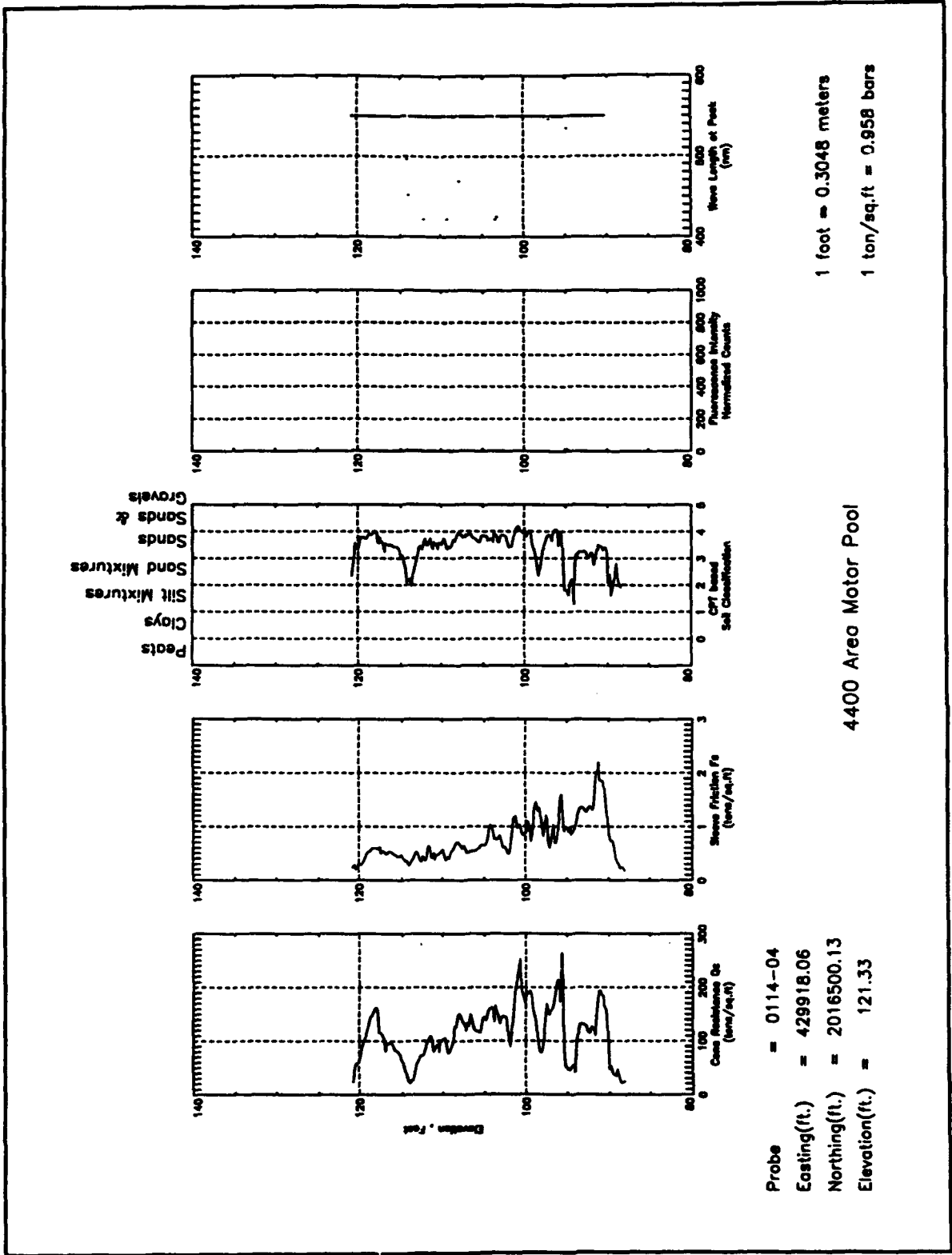

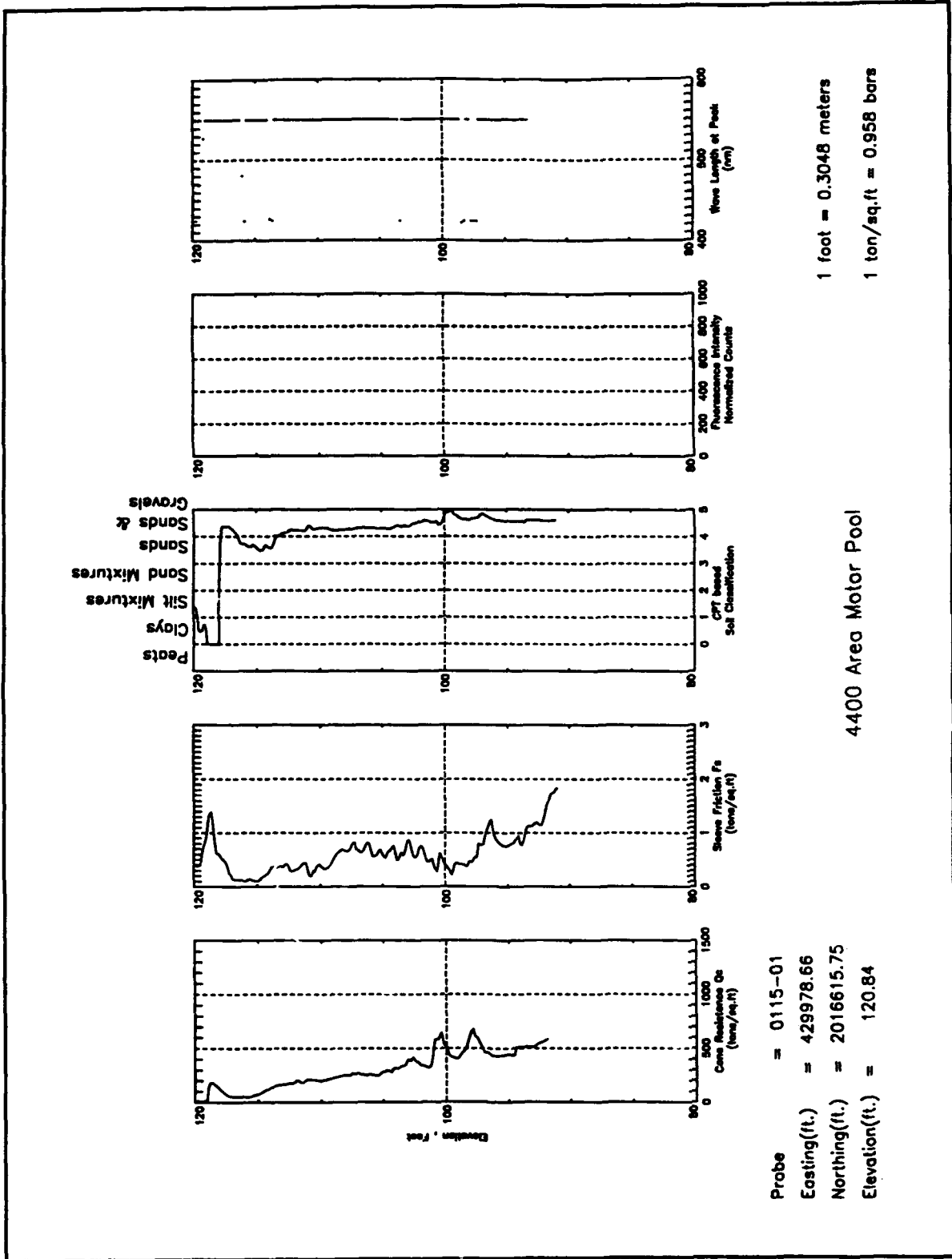

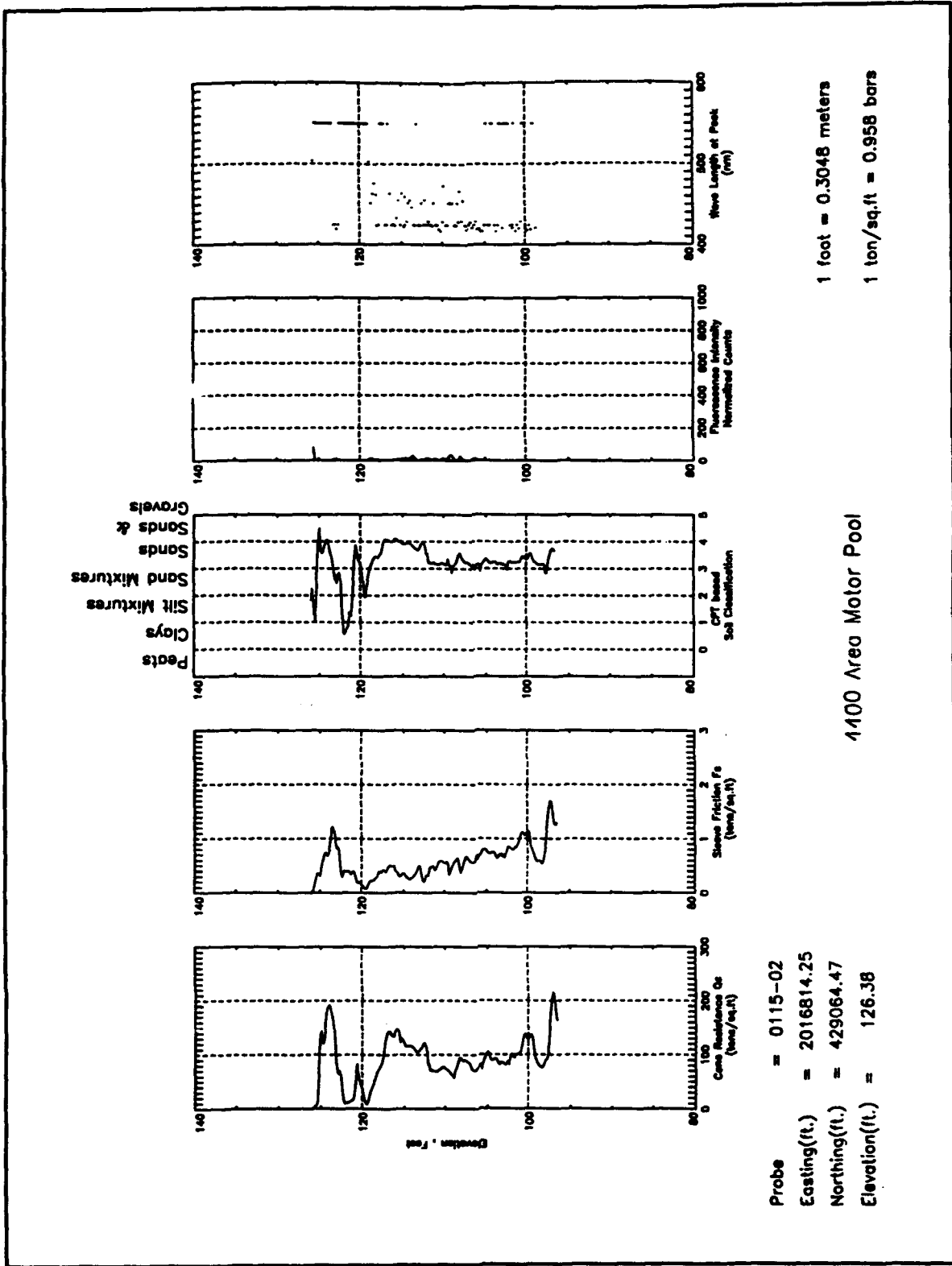

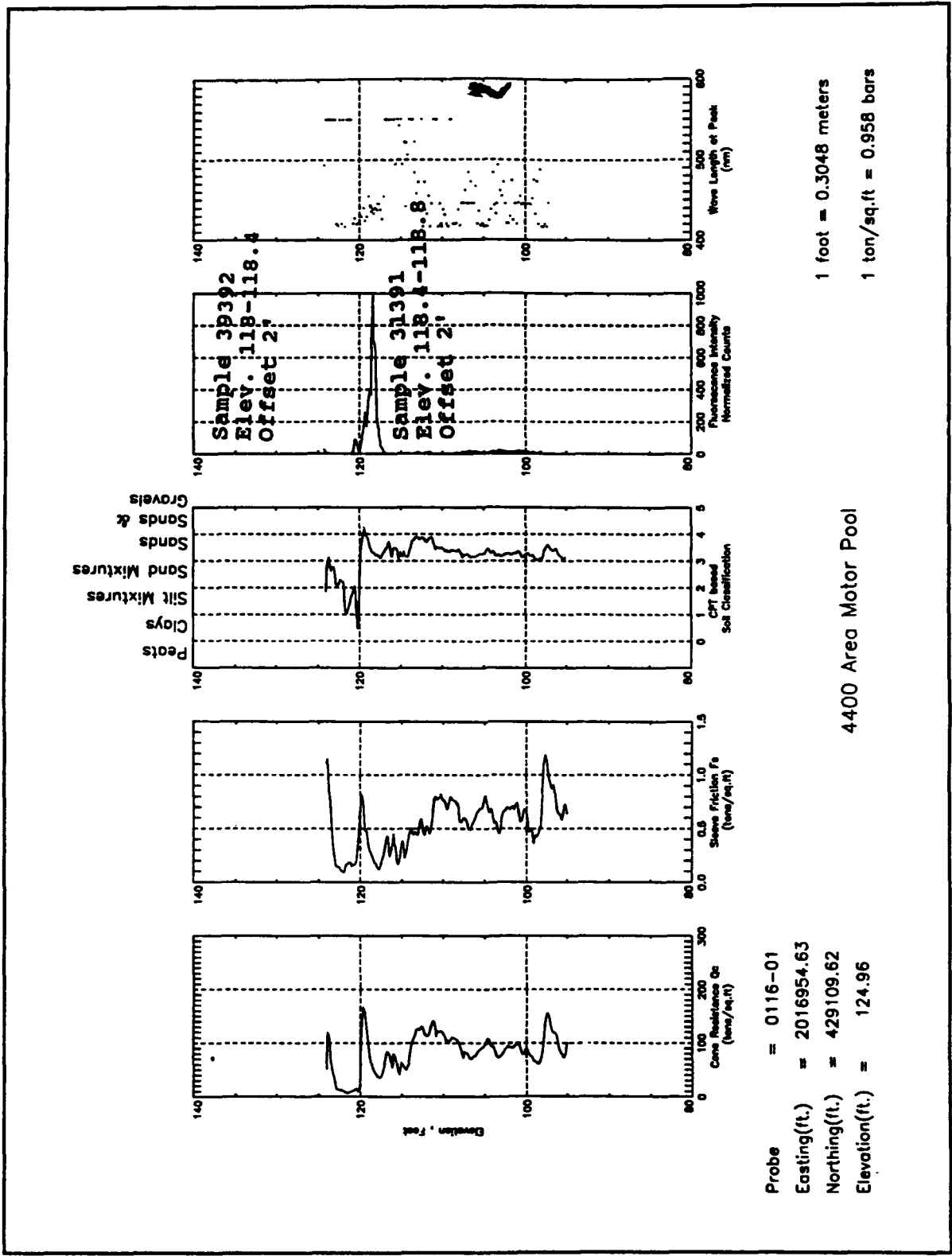

Probe = 0116-01
 Easting(ft.) = 2016954.63
 Northing(ft.) = 429109.62
 Elevation(ft.) = 124.96

1 foot = 0.3048 meters
 1 ton/sq.ft = 0.958 bars

4400 Area Motor Pool

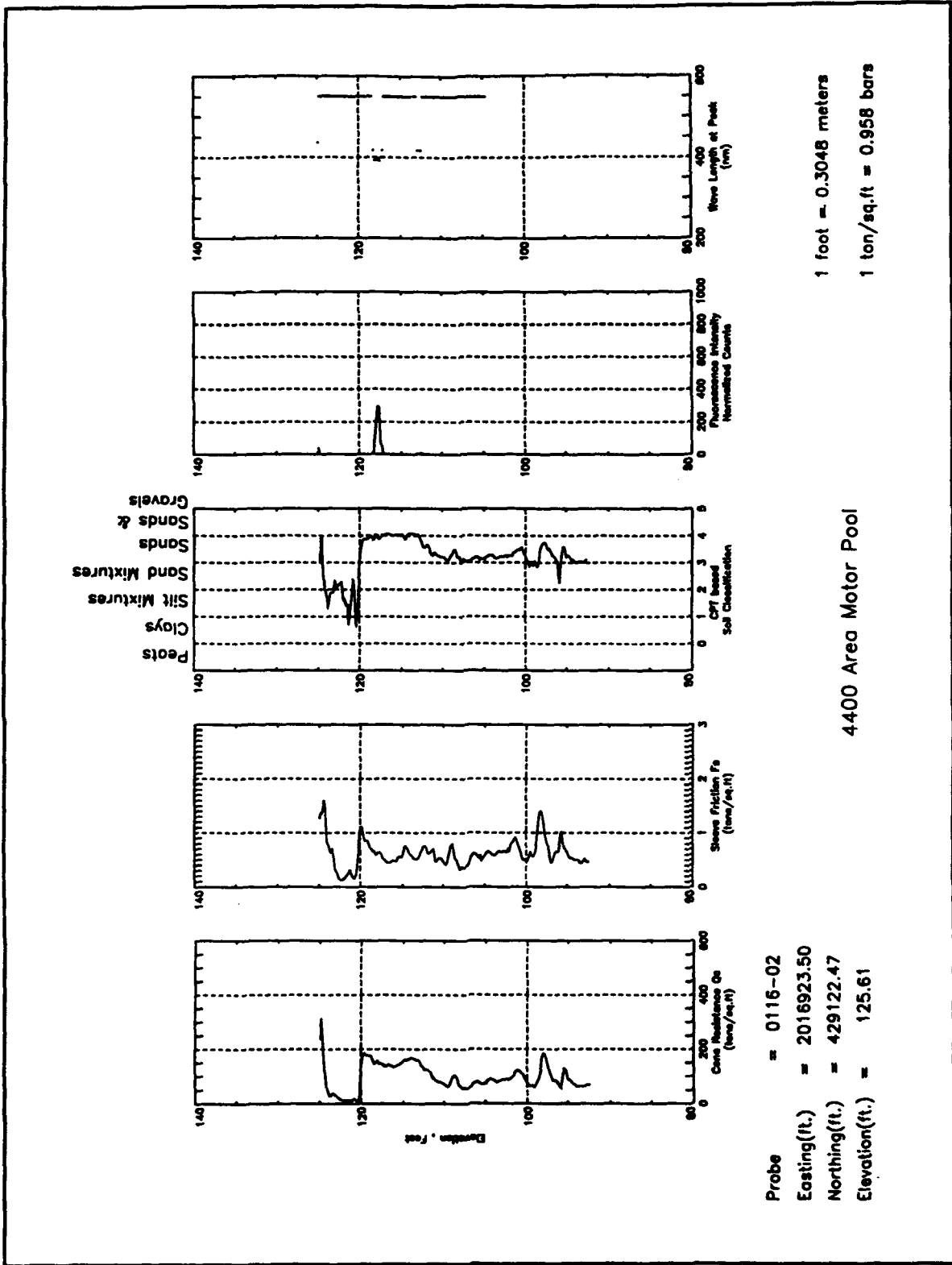

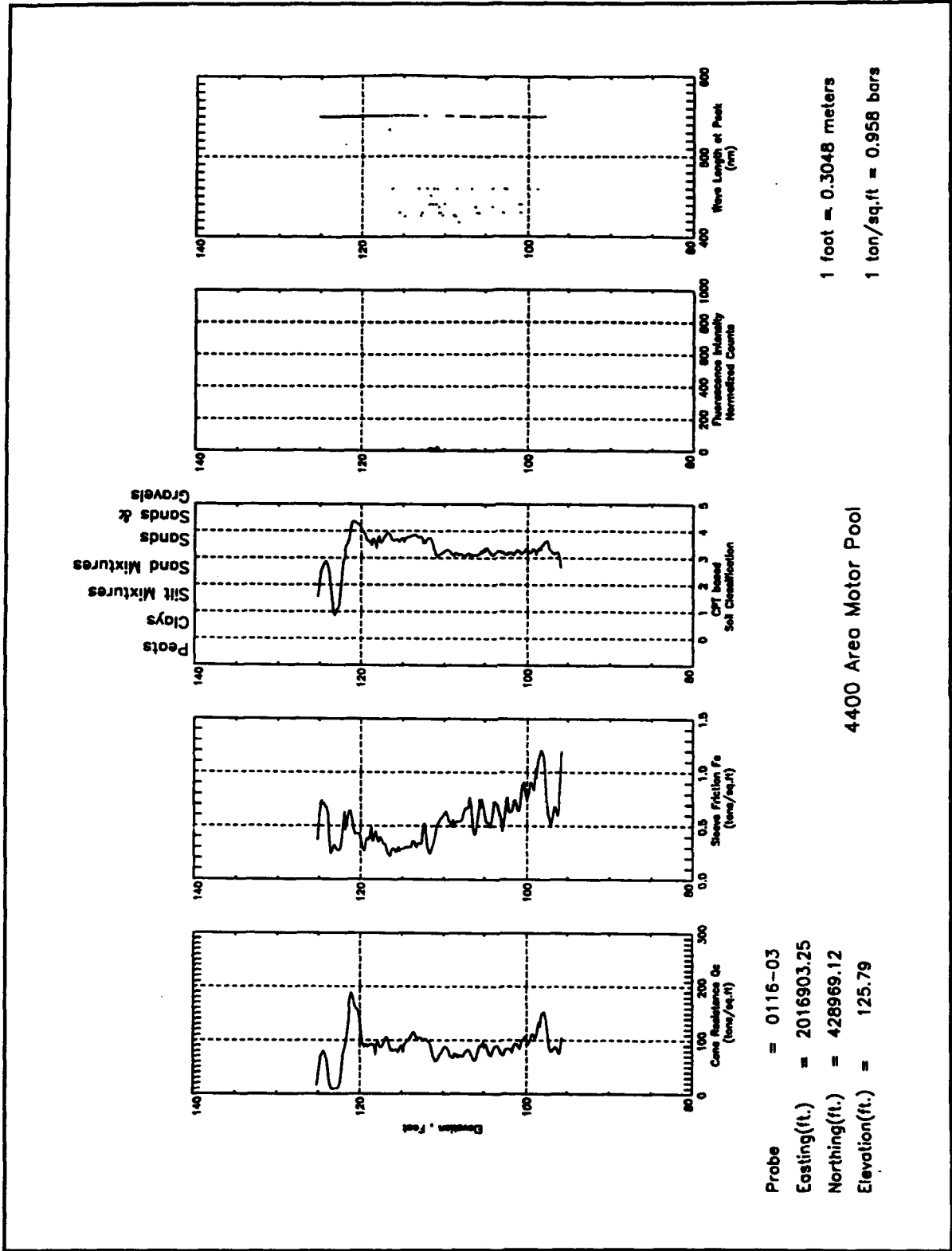

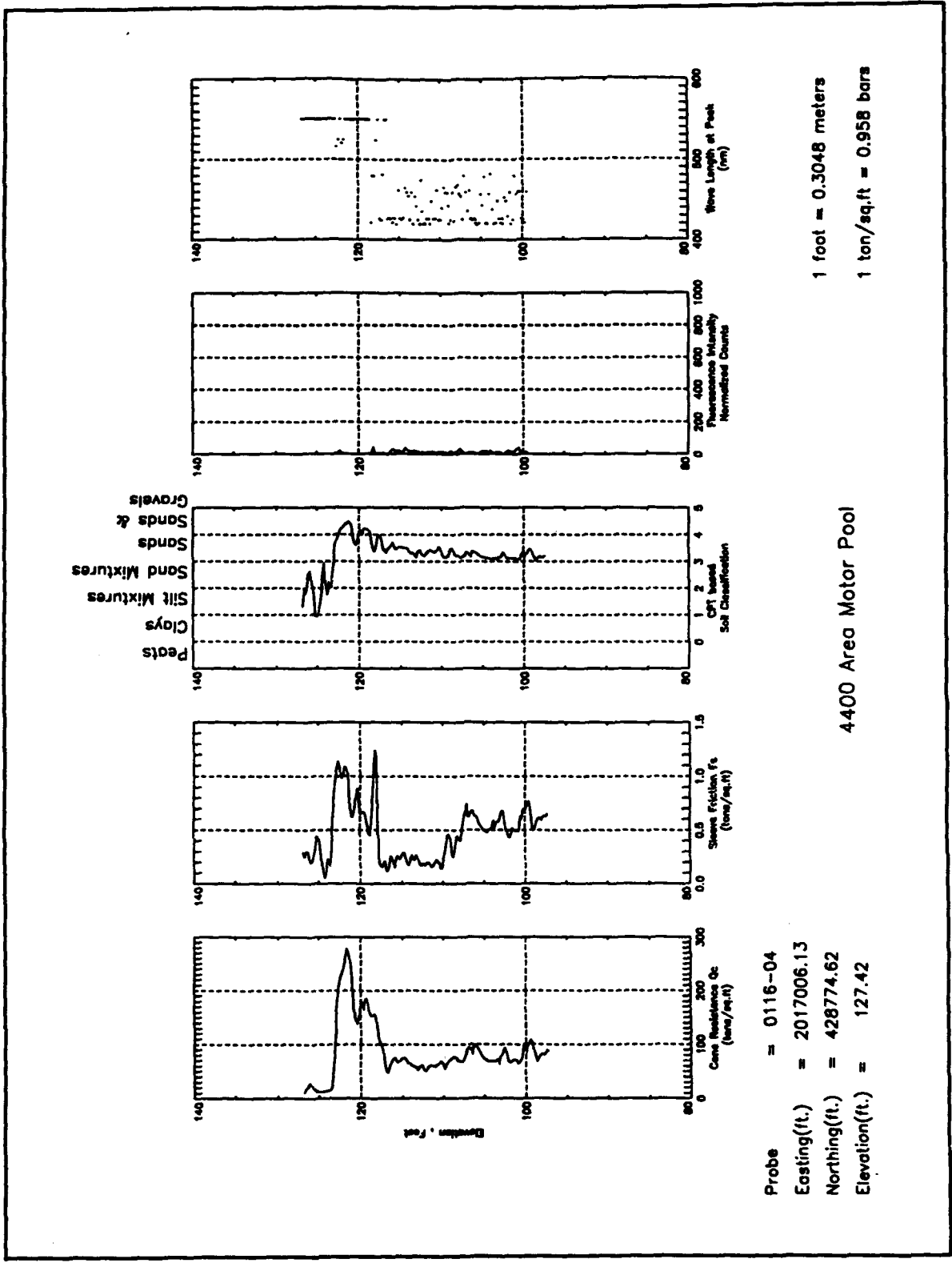

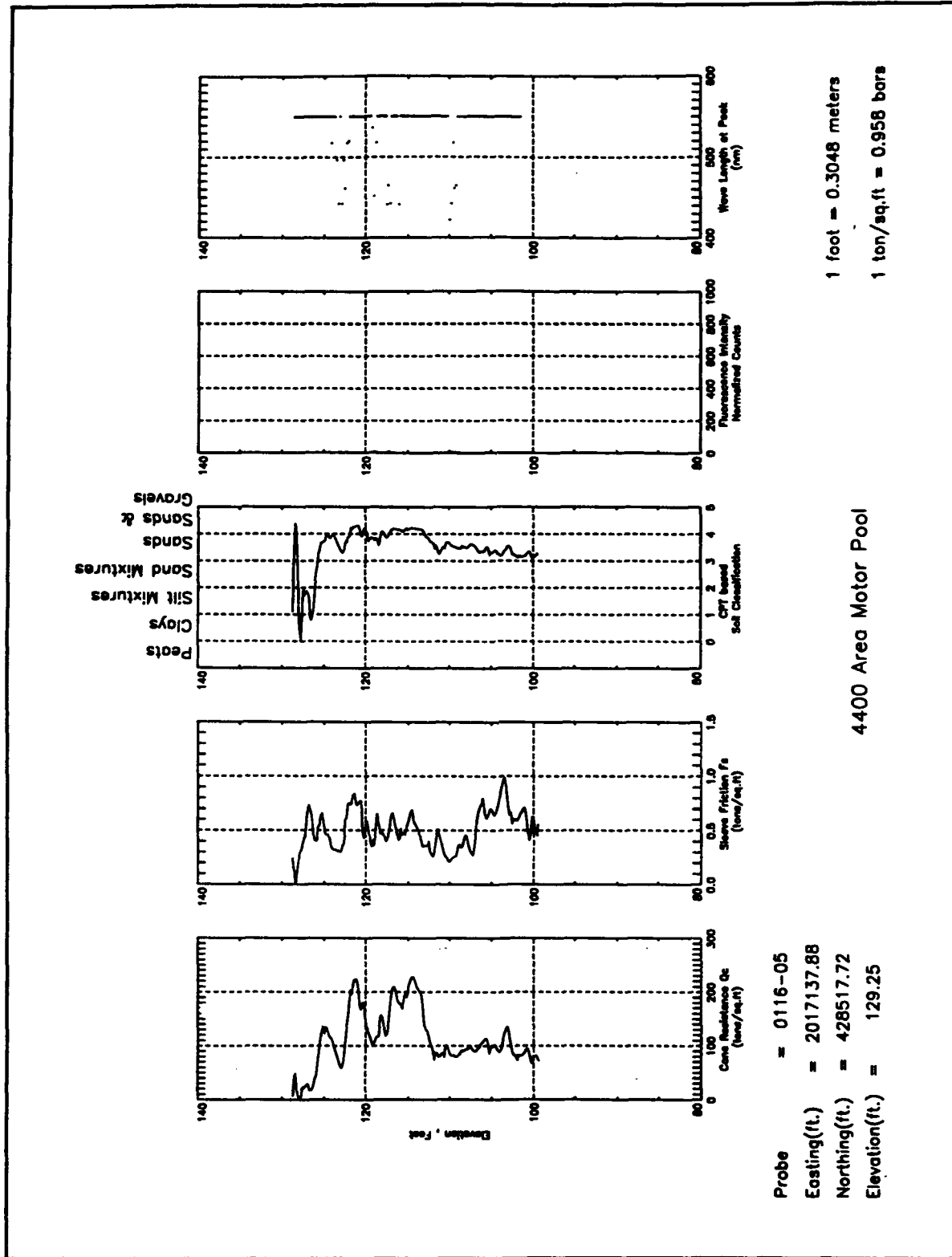

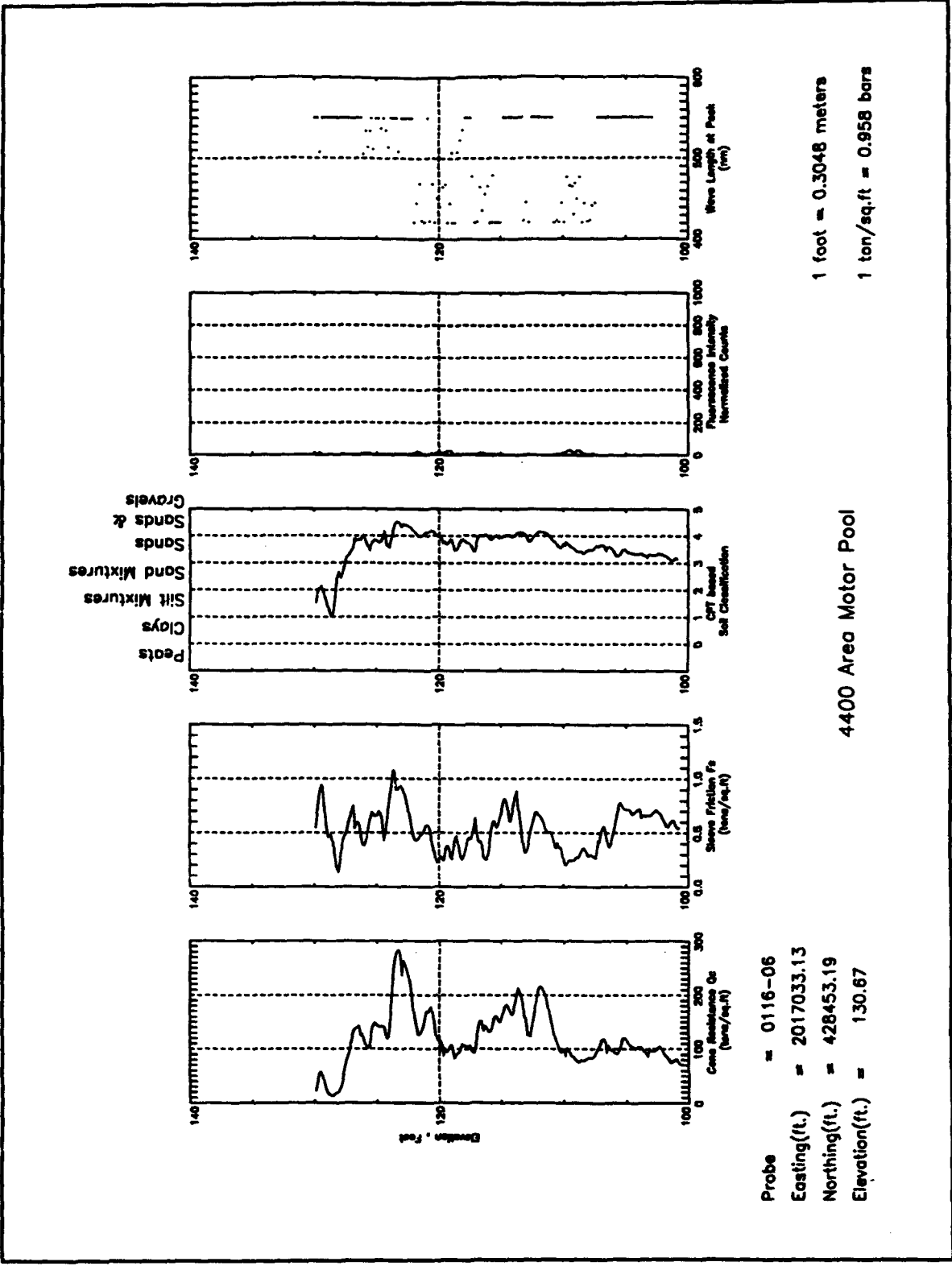

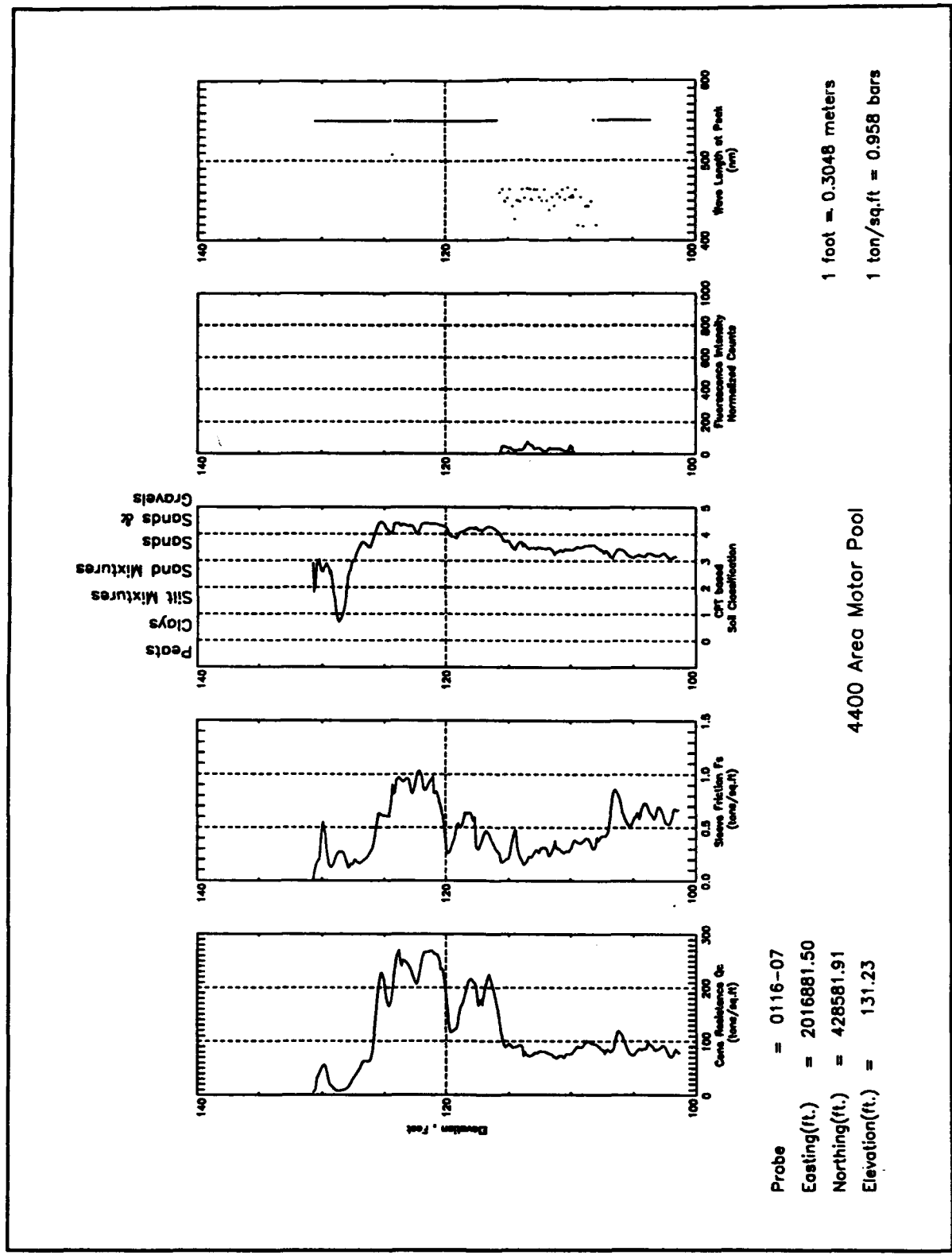

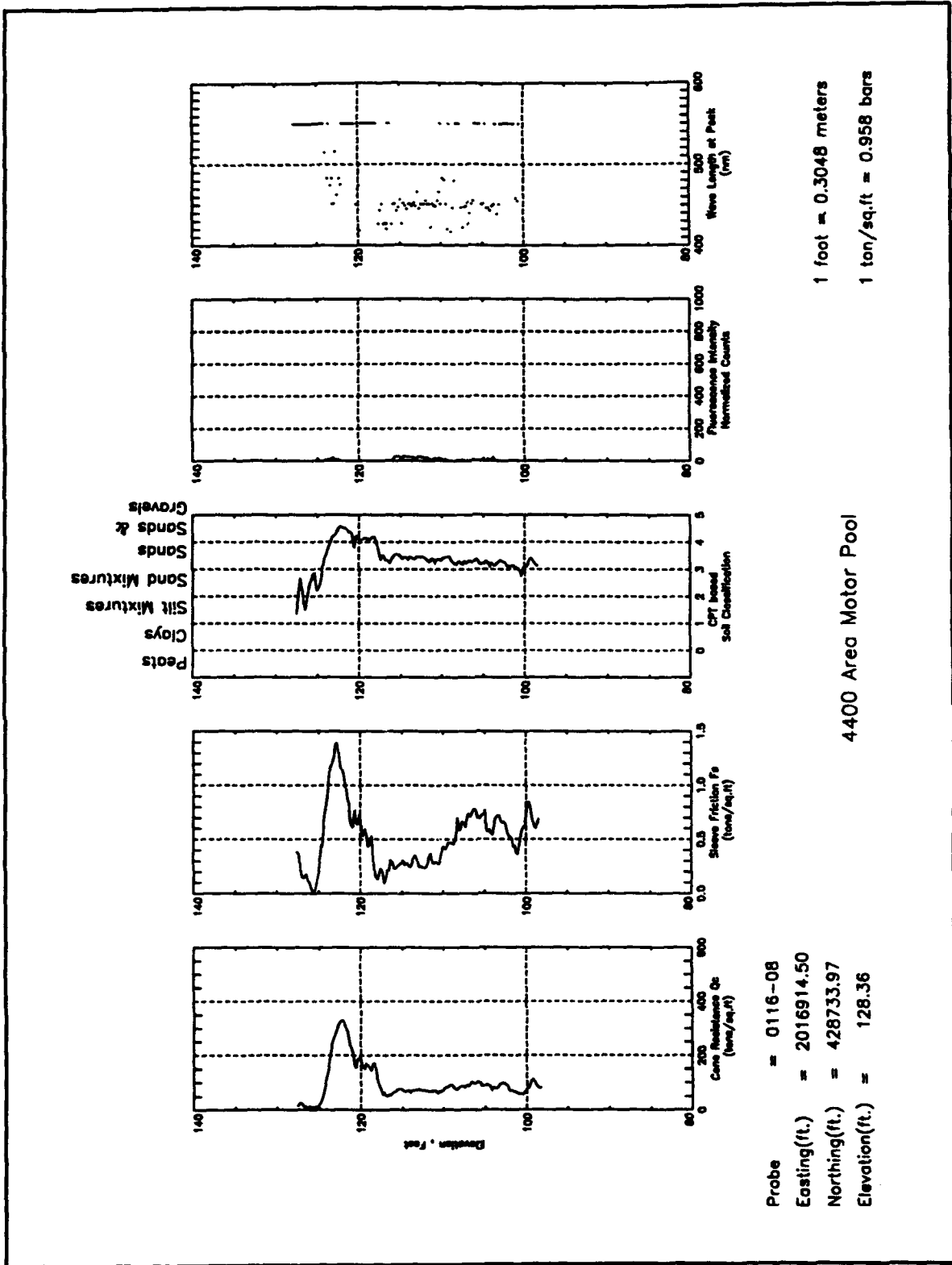

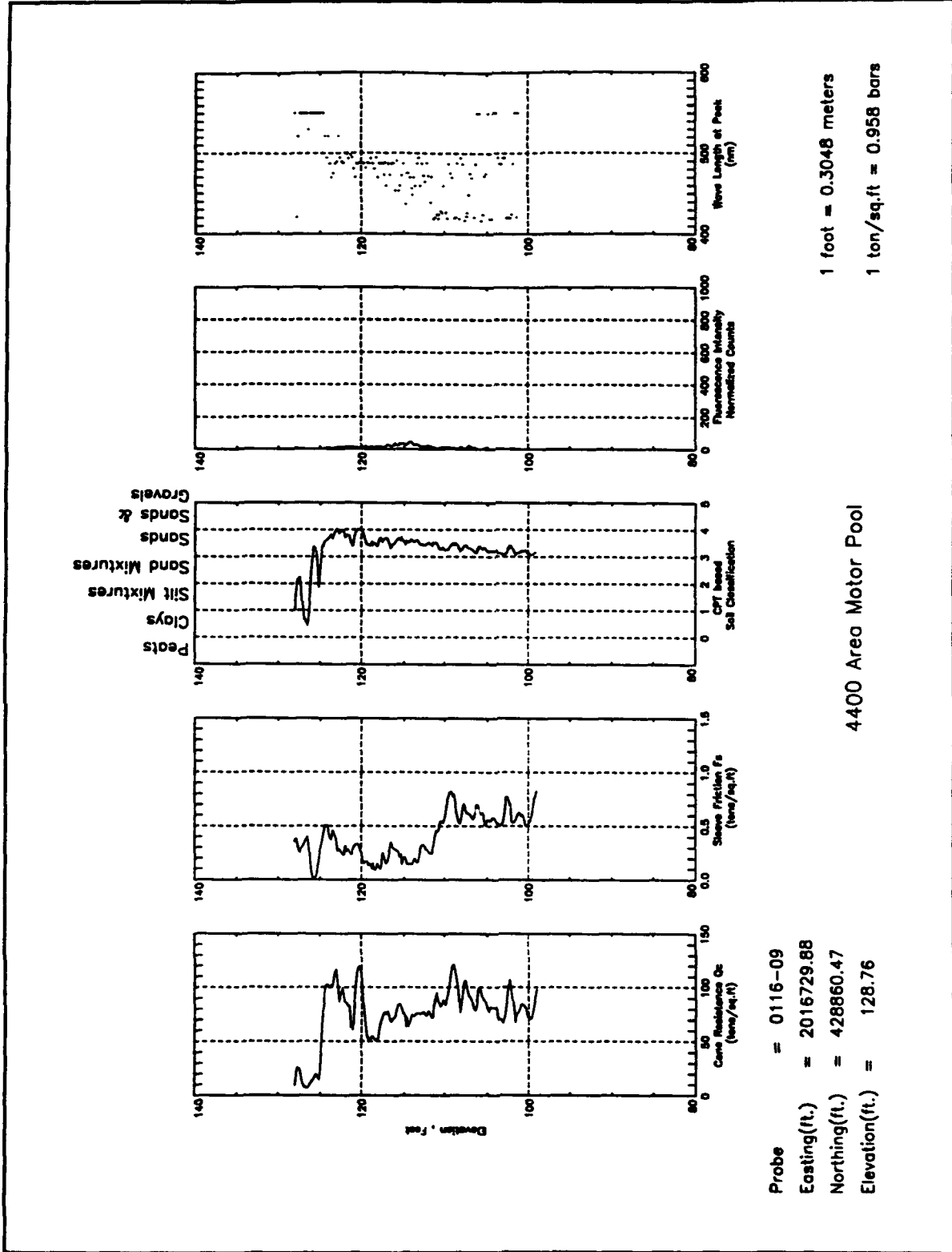

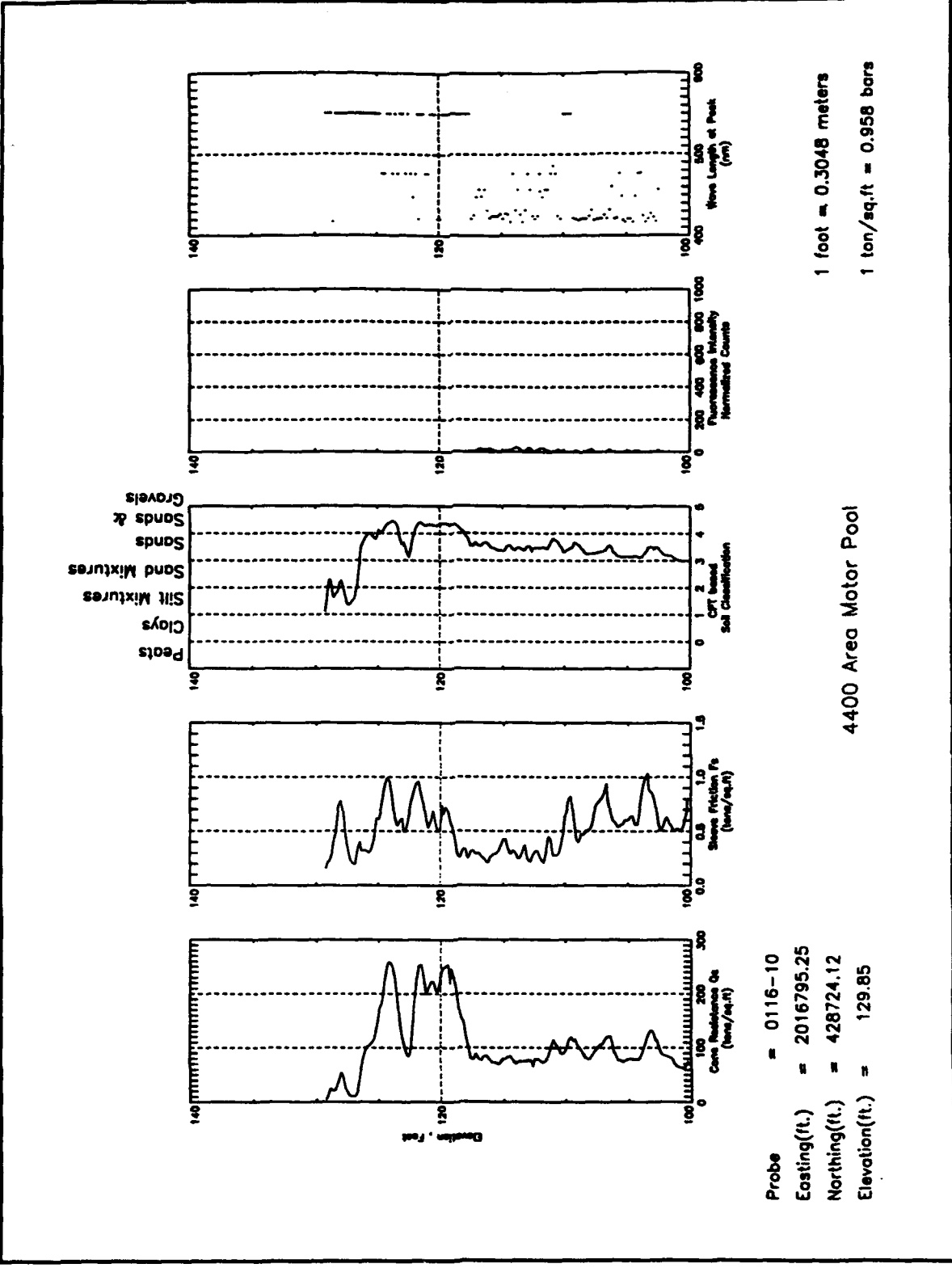

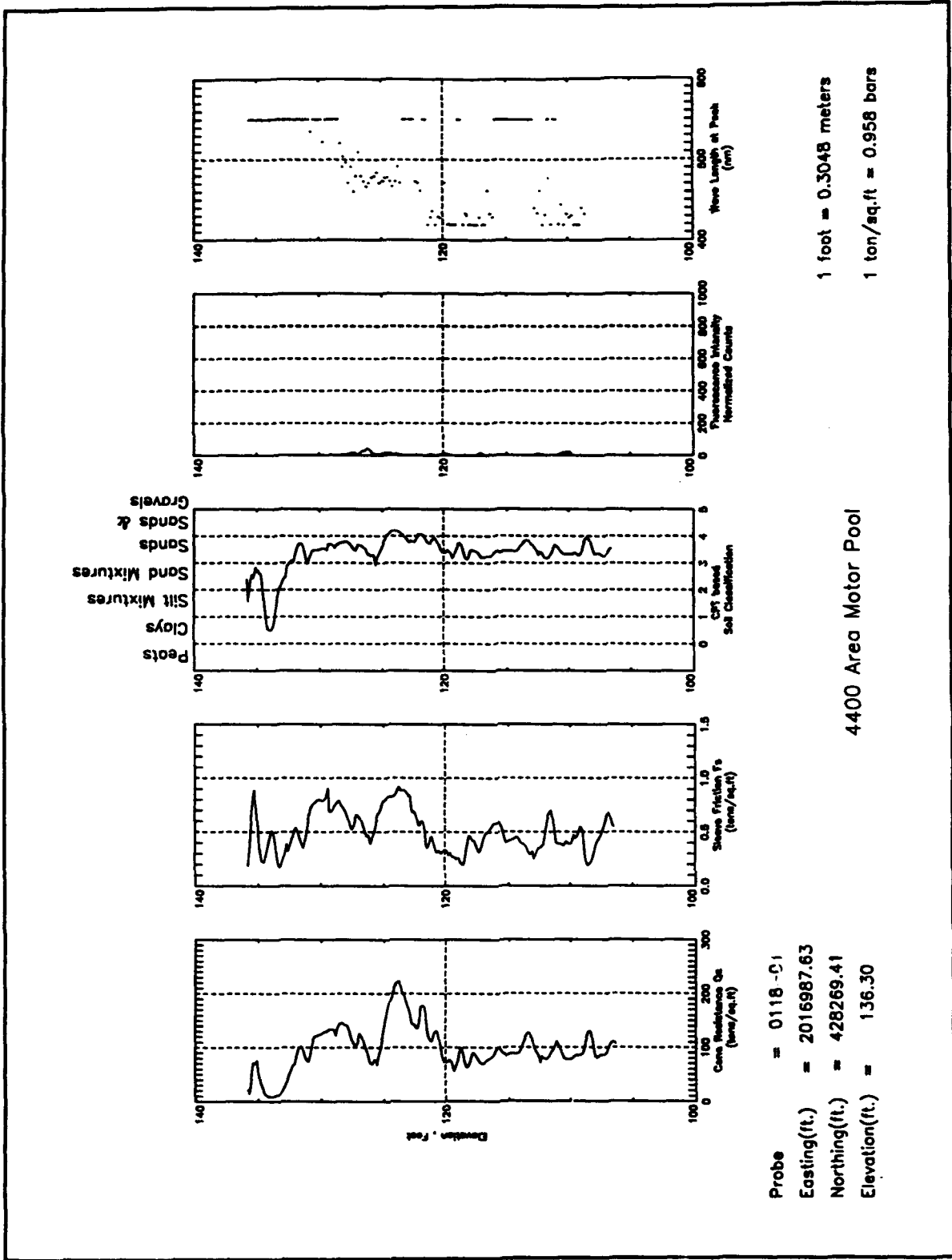

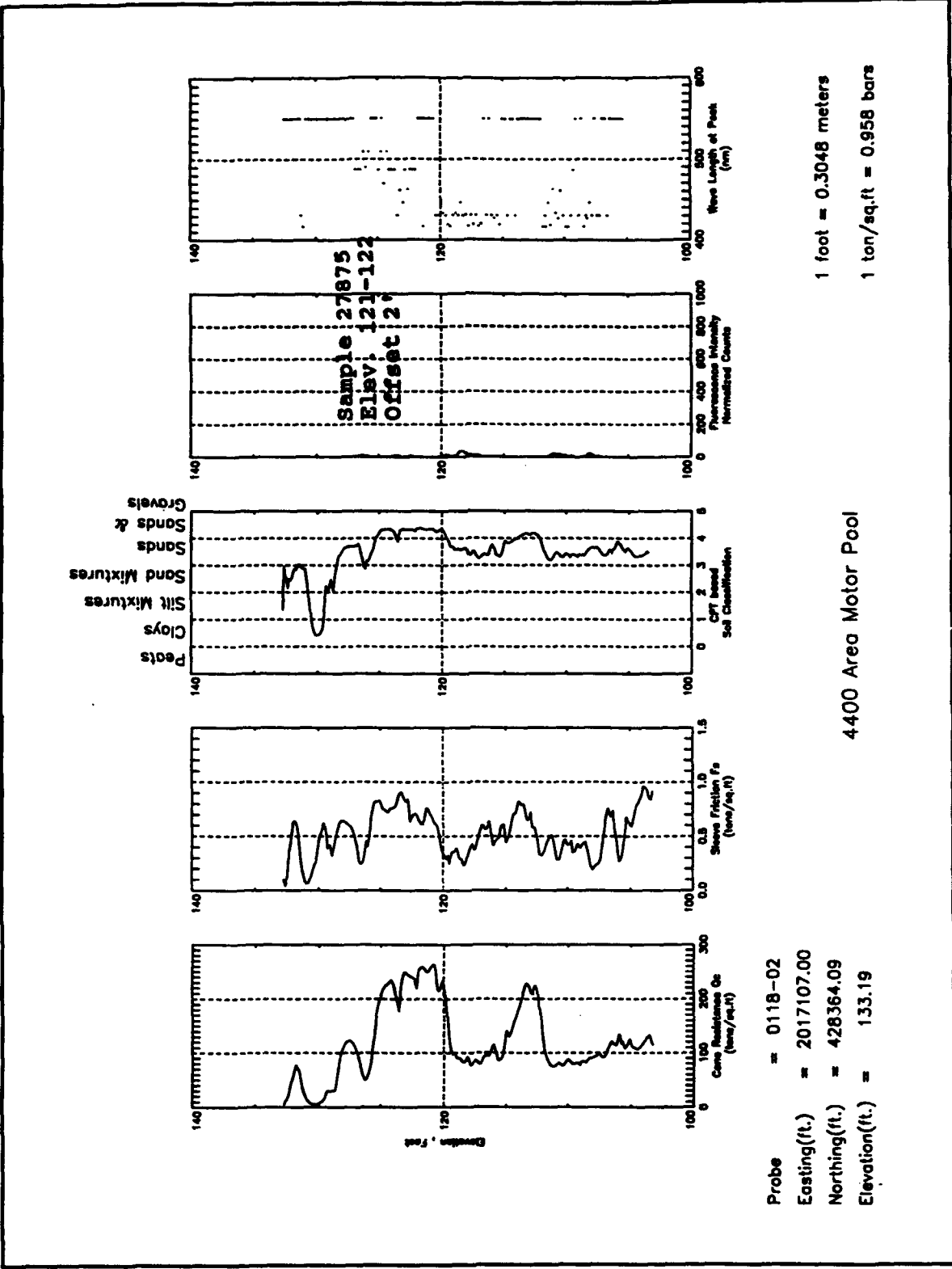

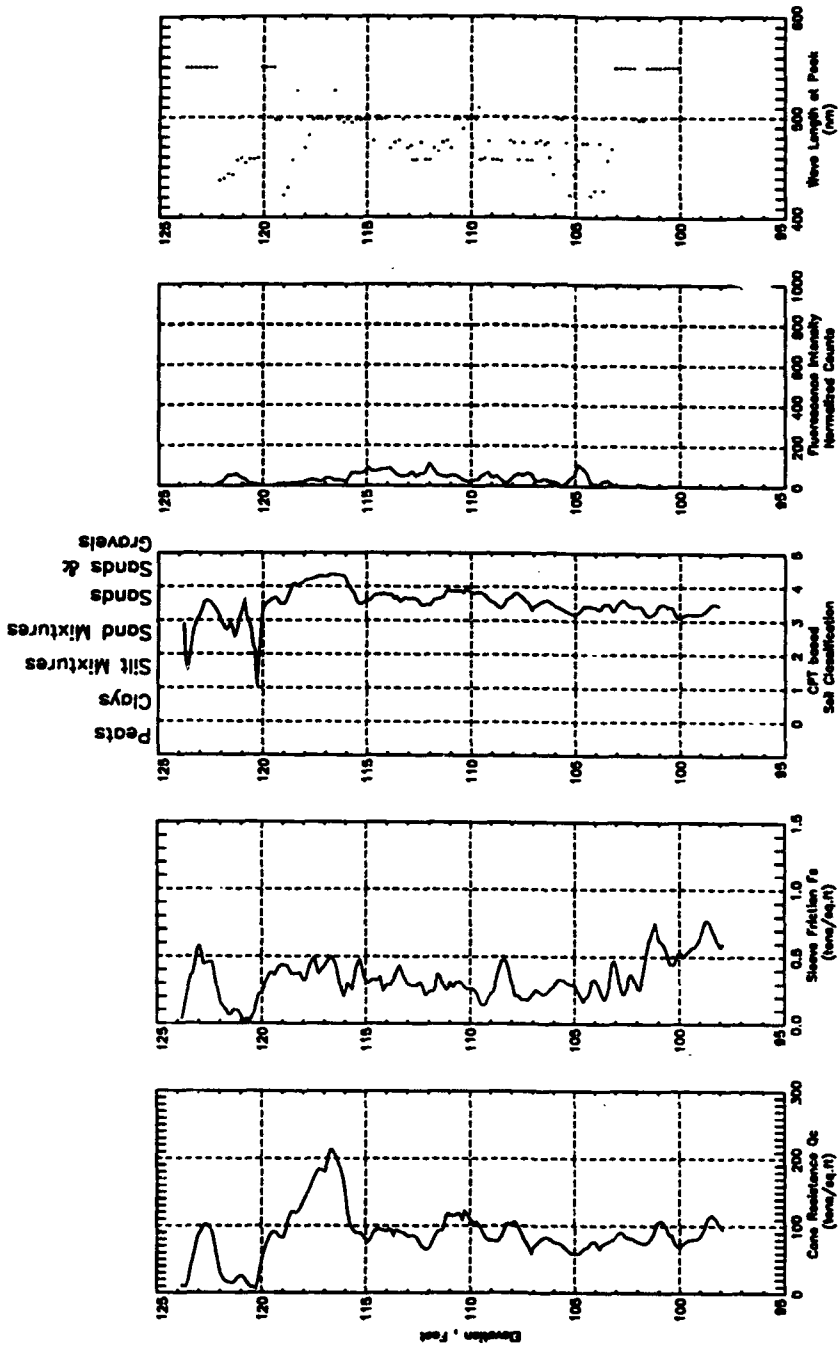

Probe = 0118-03
 Easting(ft.) = 2017711.00
 Northing(ft.) = 428520.97
 Elevation(ft.) = 124.38

1 foot = 0.3048 meters
 1 ton/sq.ft = 0.958 bars

4400 Area Motor Pool

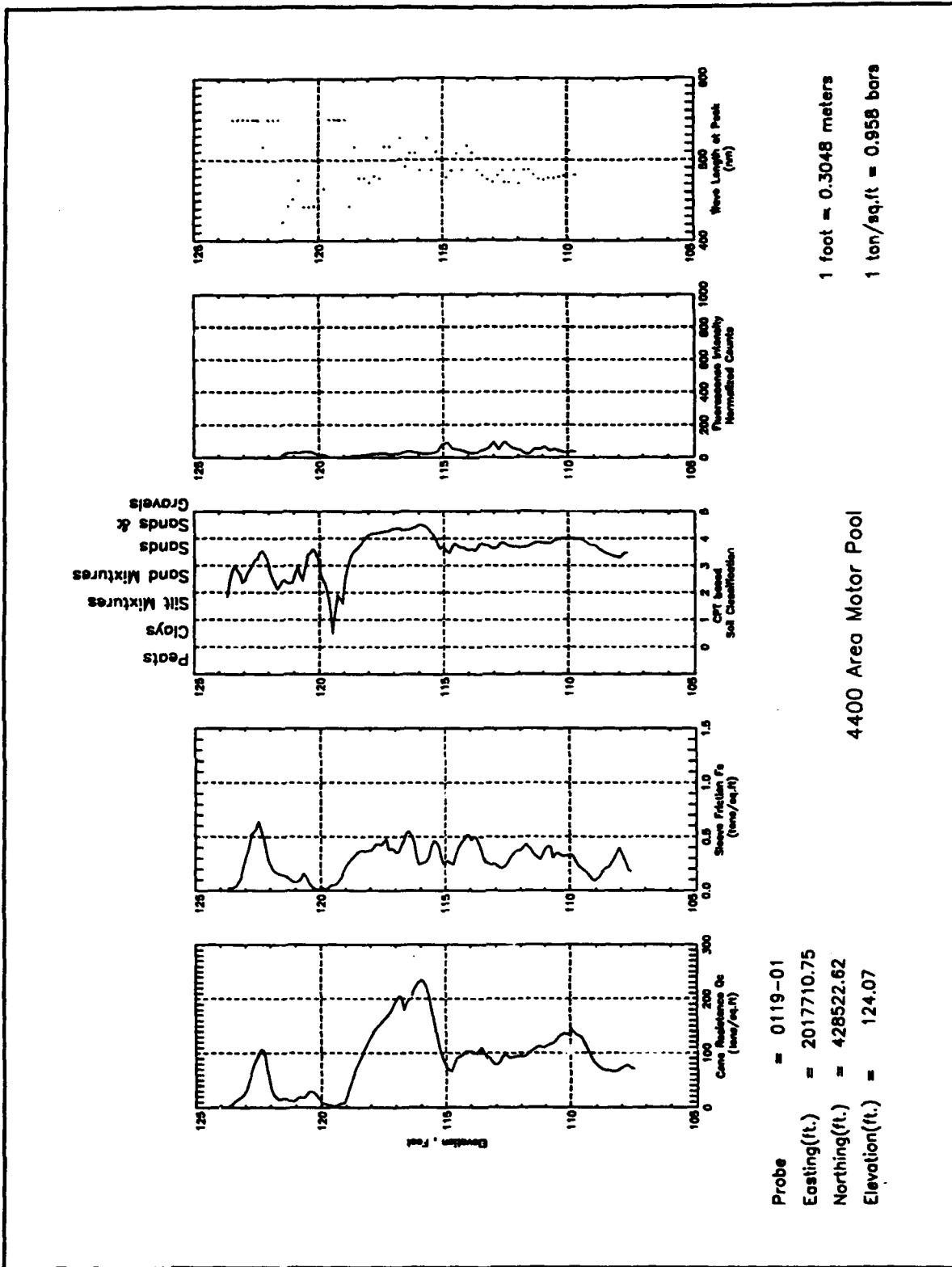

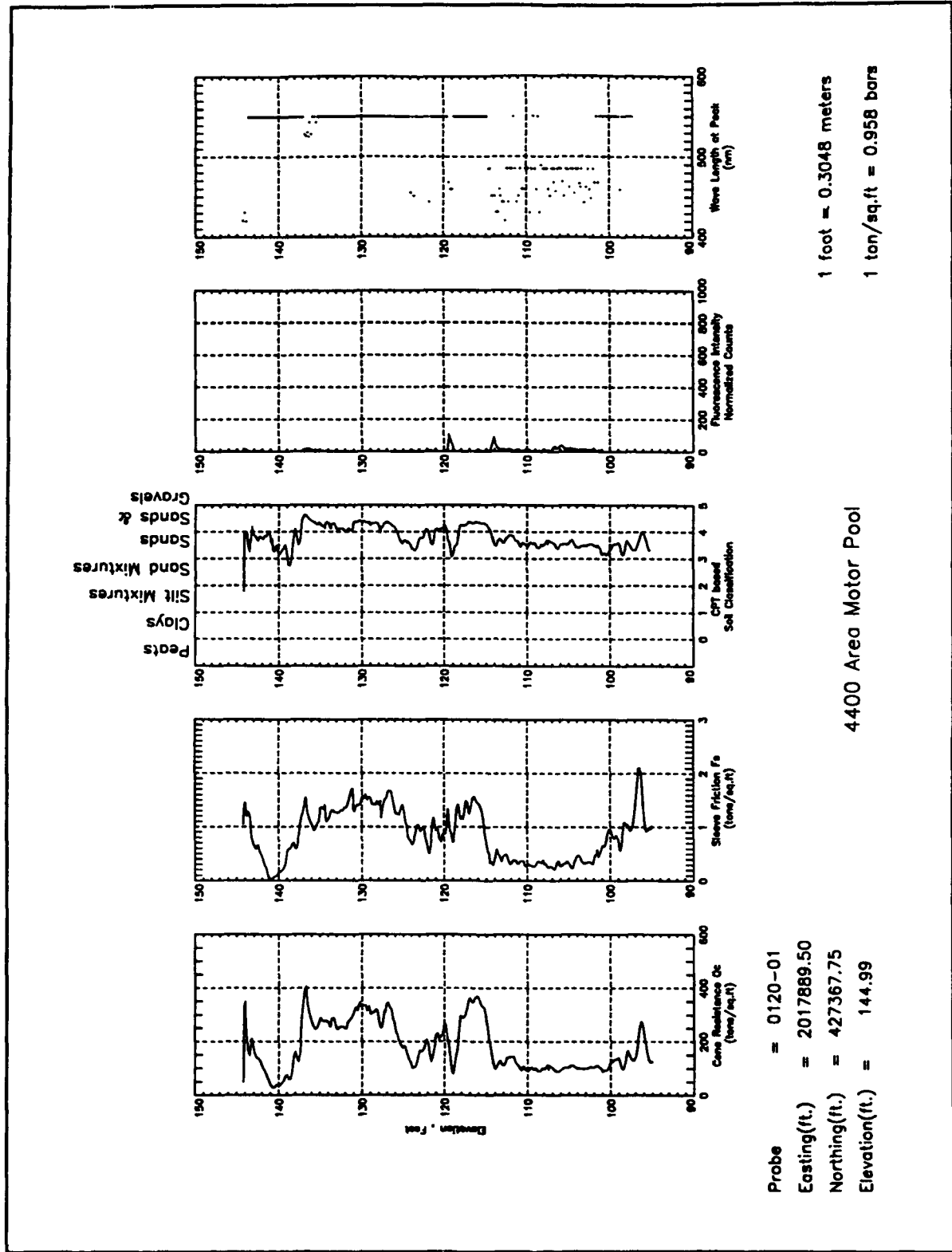

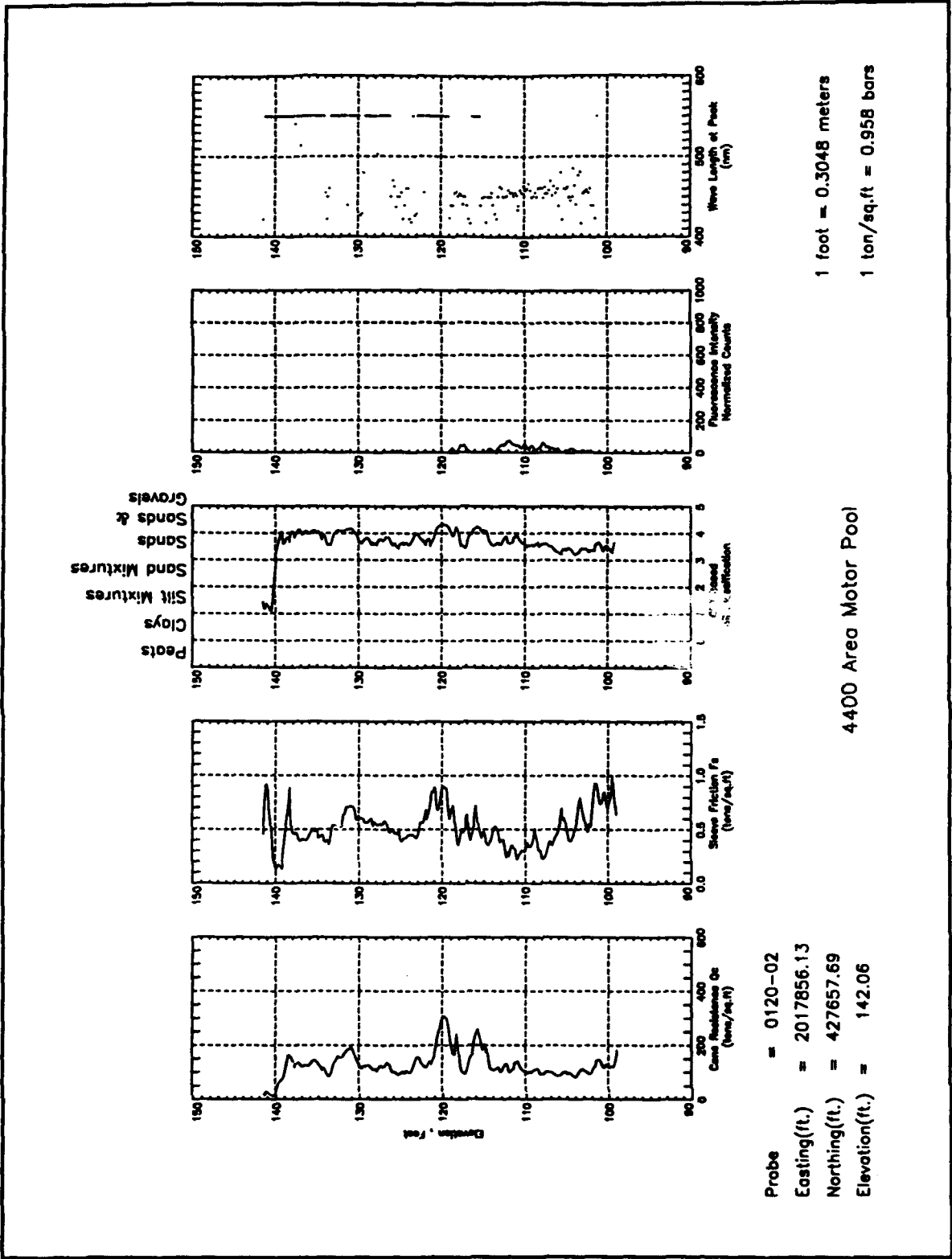

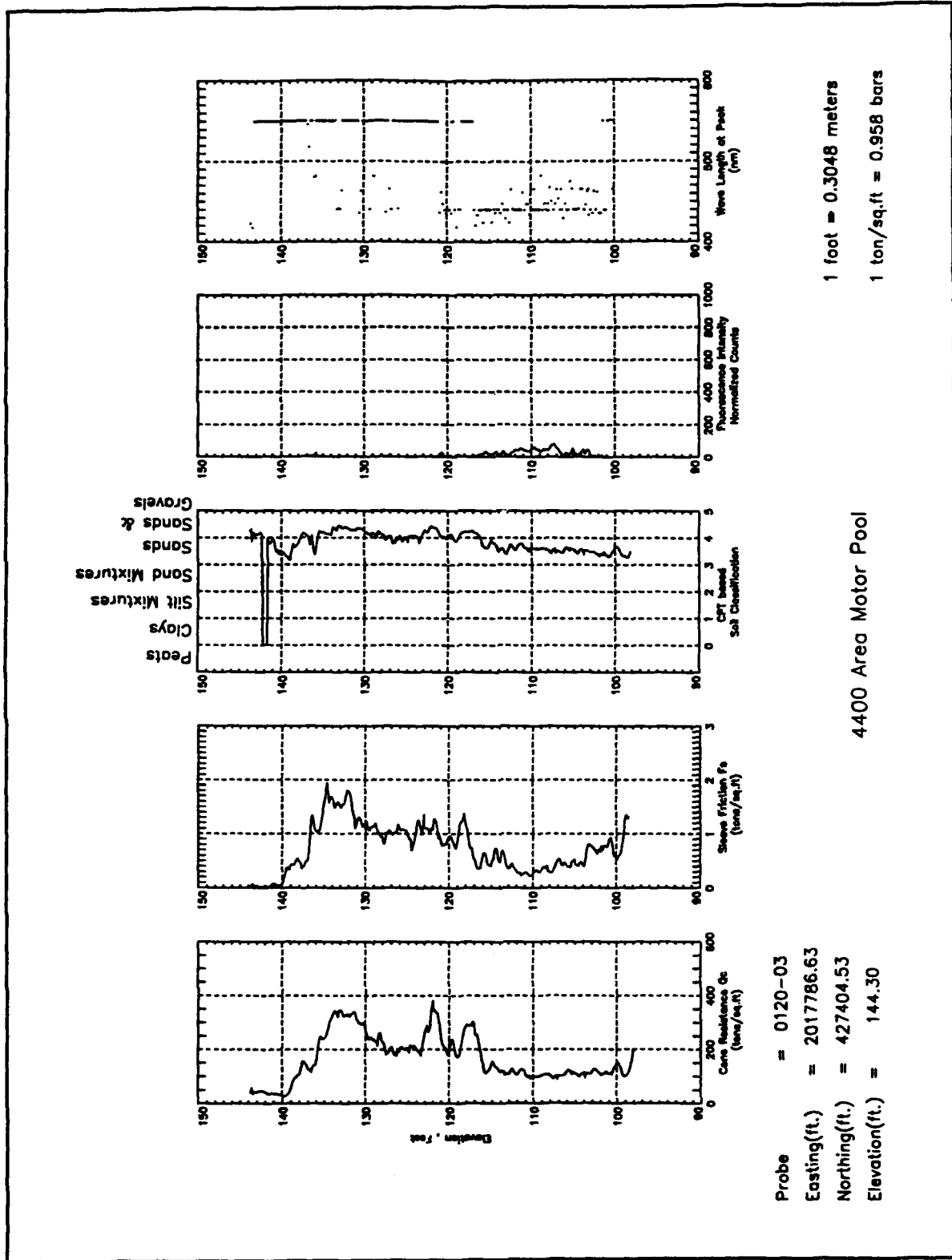

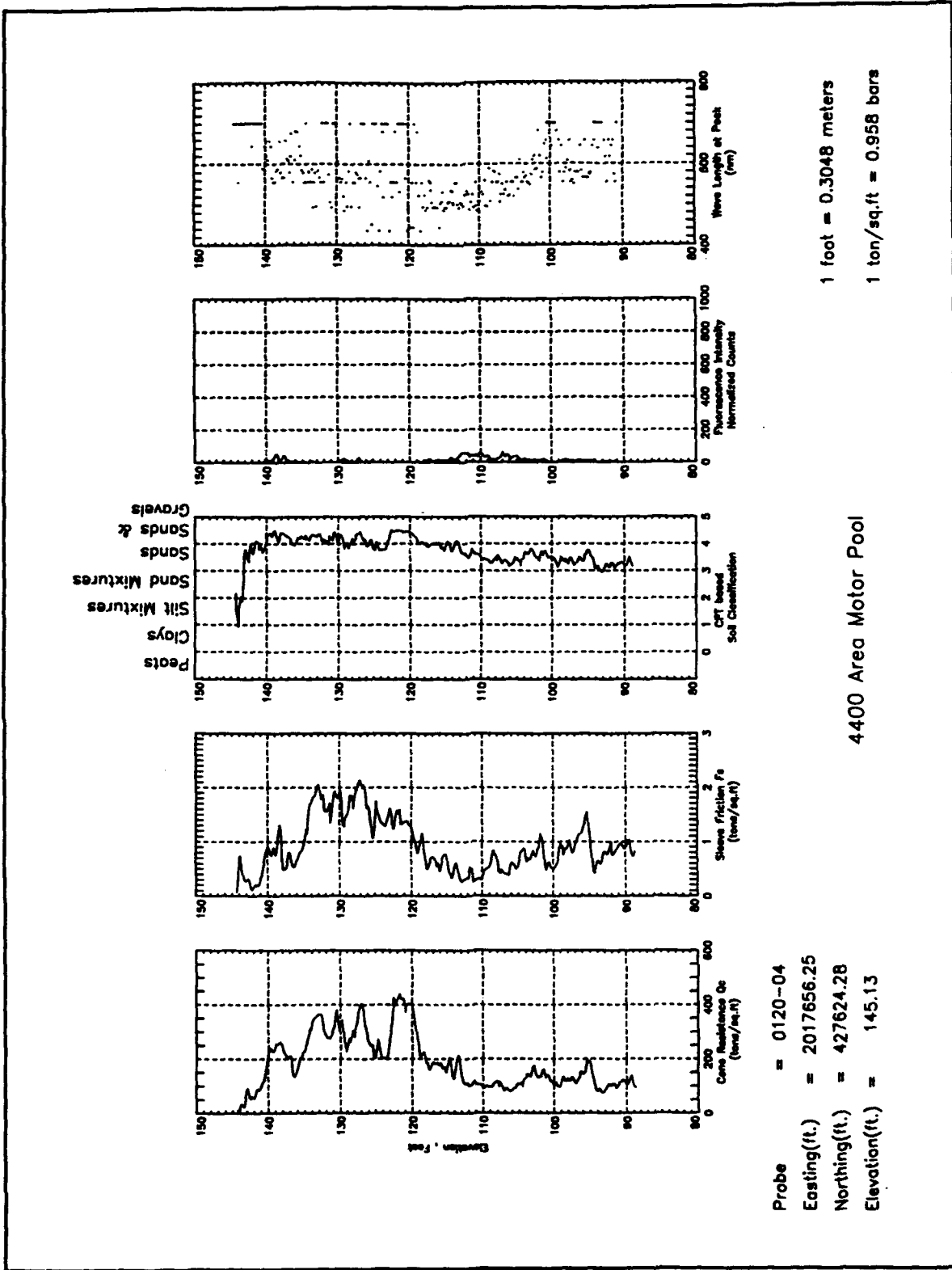

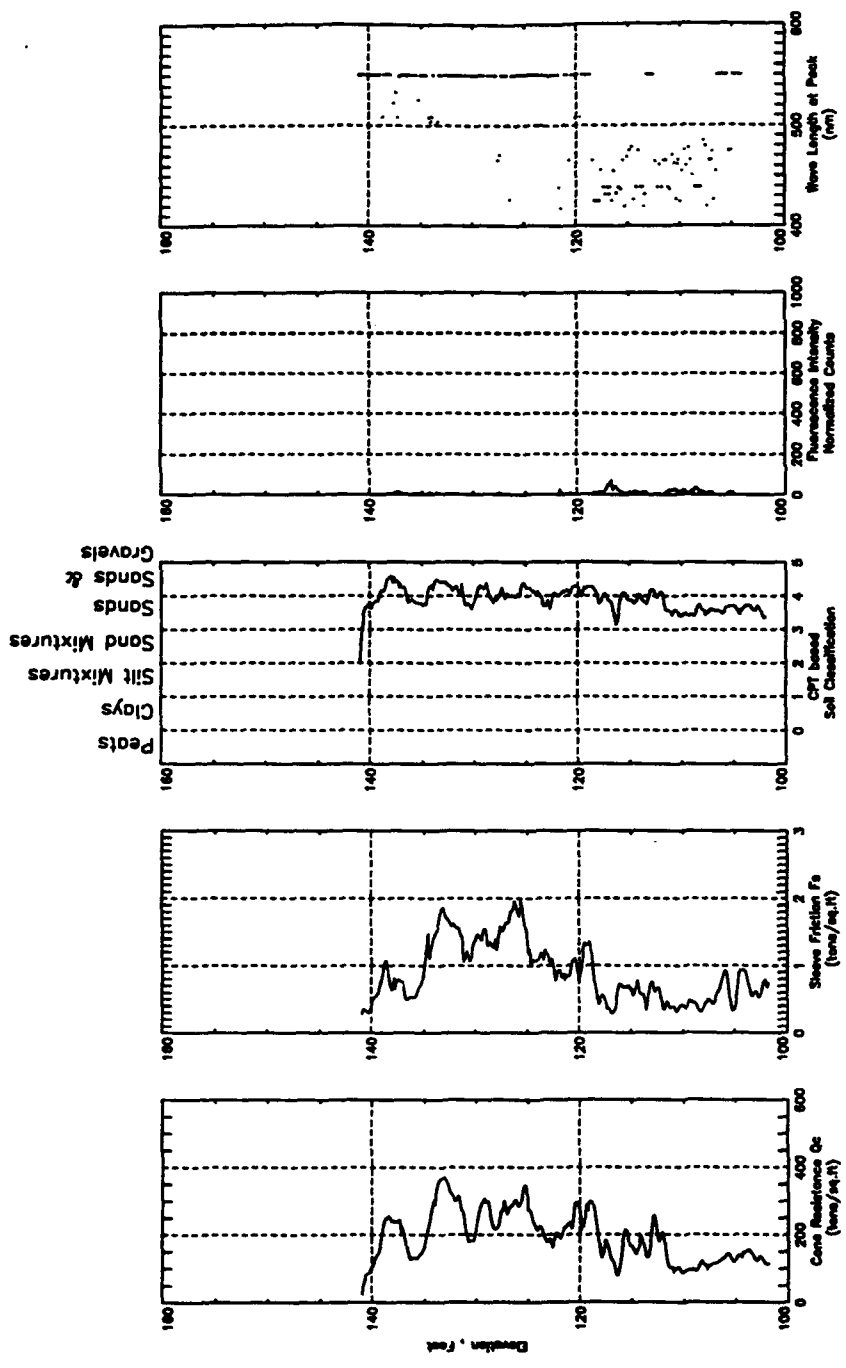

Probe = 0120-05
 Easting(ft.) = 2017470.25
 Northing(ft.) = 427782.84
 Elevation(ft.) = 141.60

4400 Area Motor Pool

1 foot = 0.3048 meters
 1 ton/sq.ft = 0.958 bars

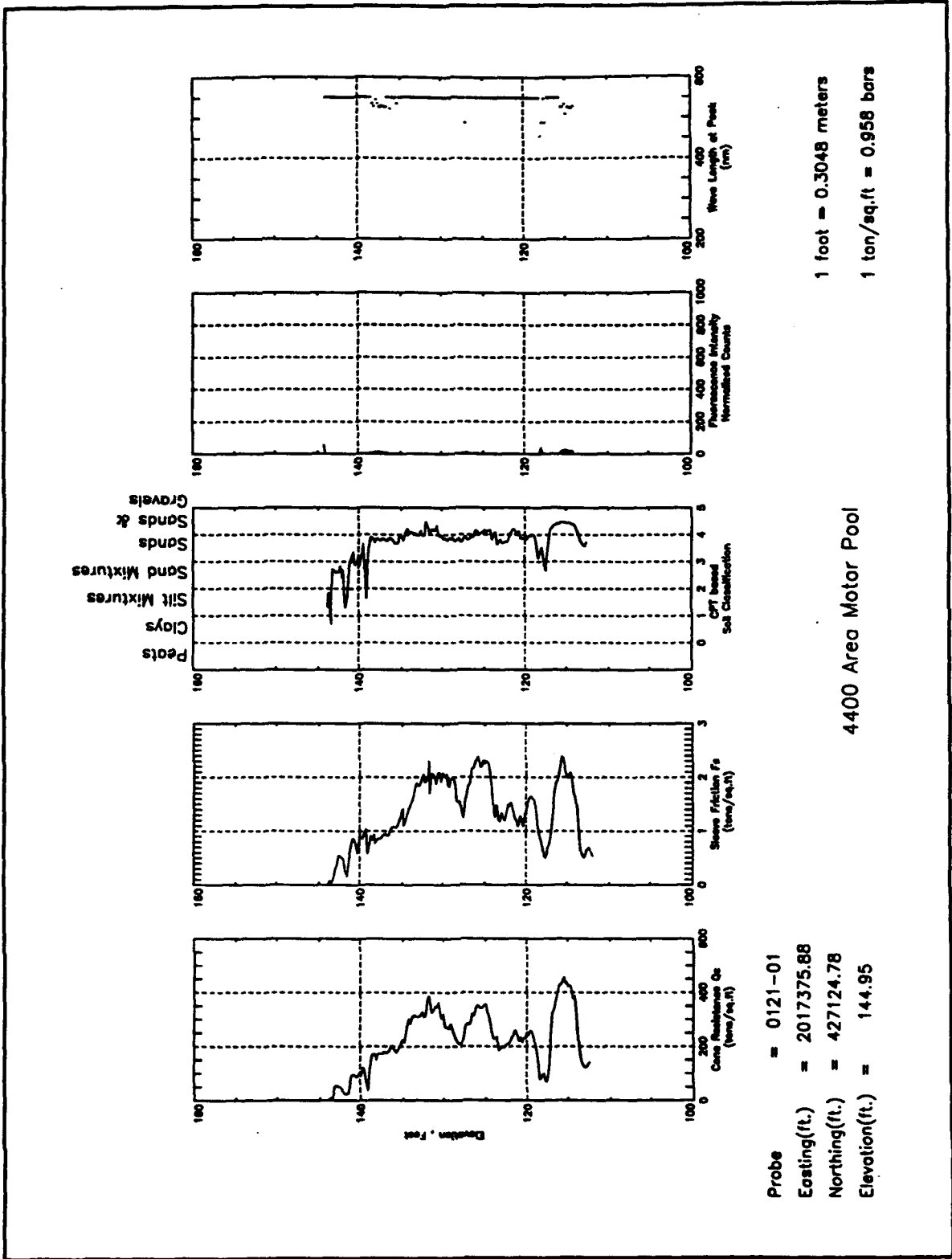

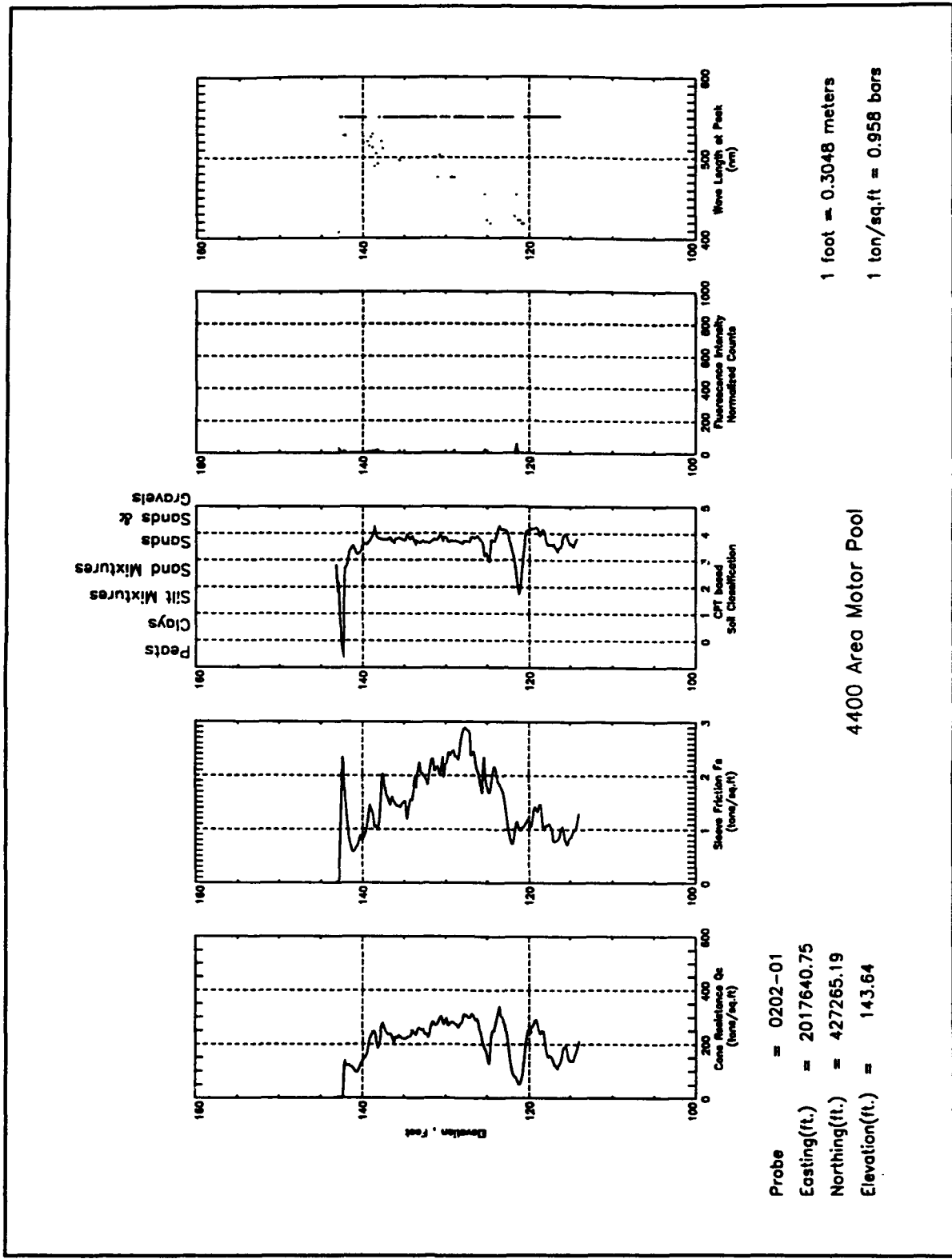

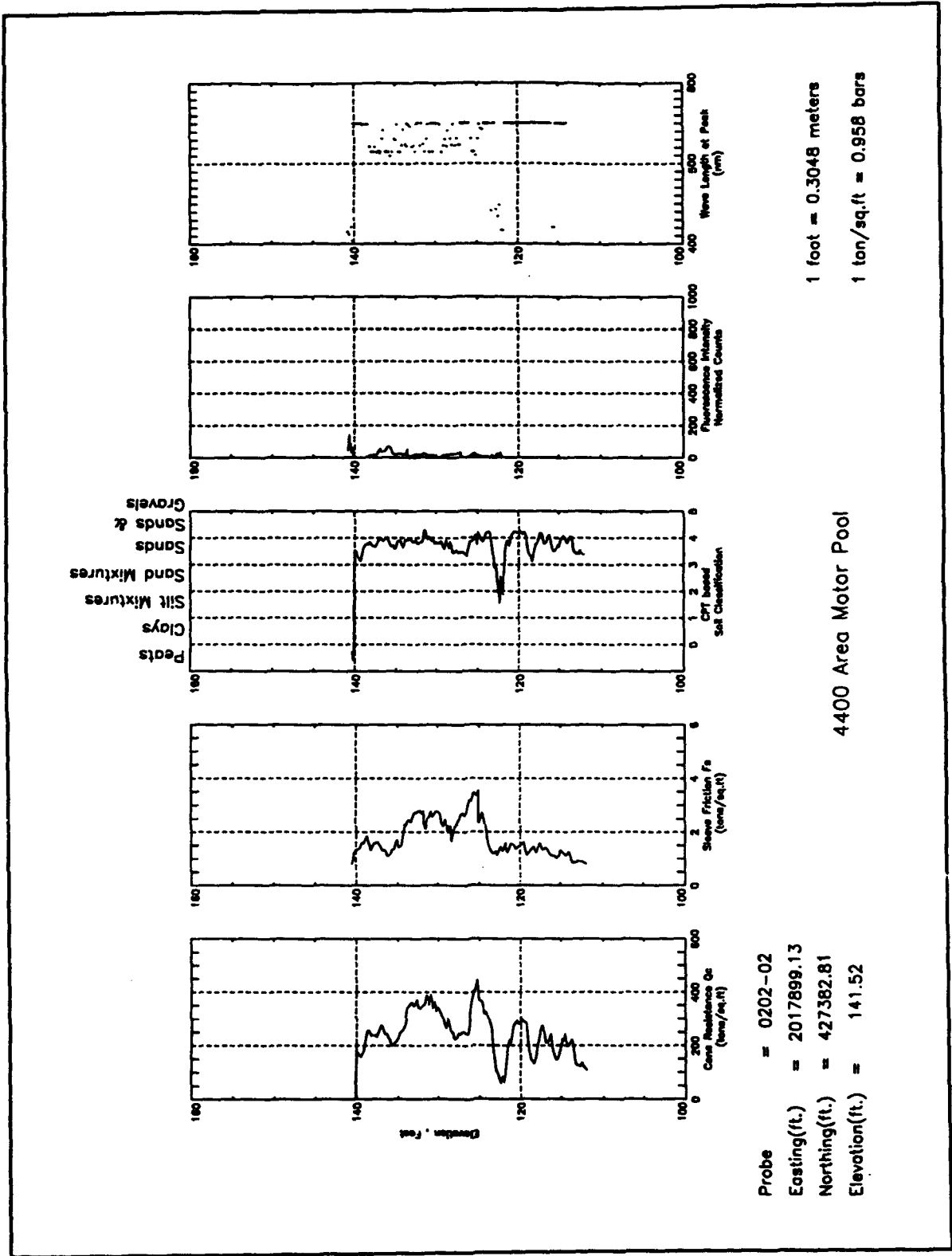

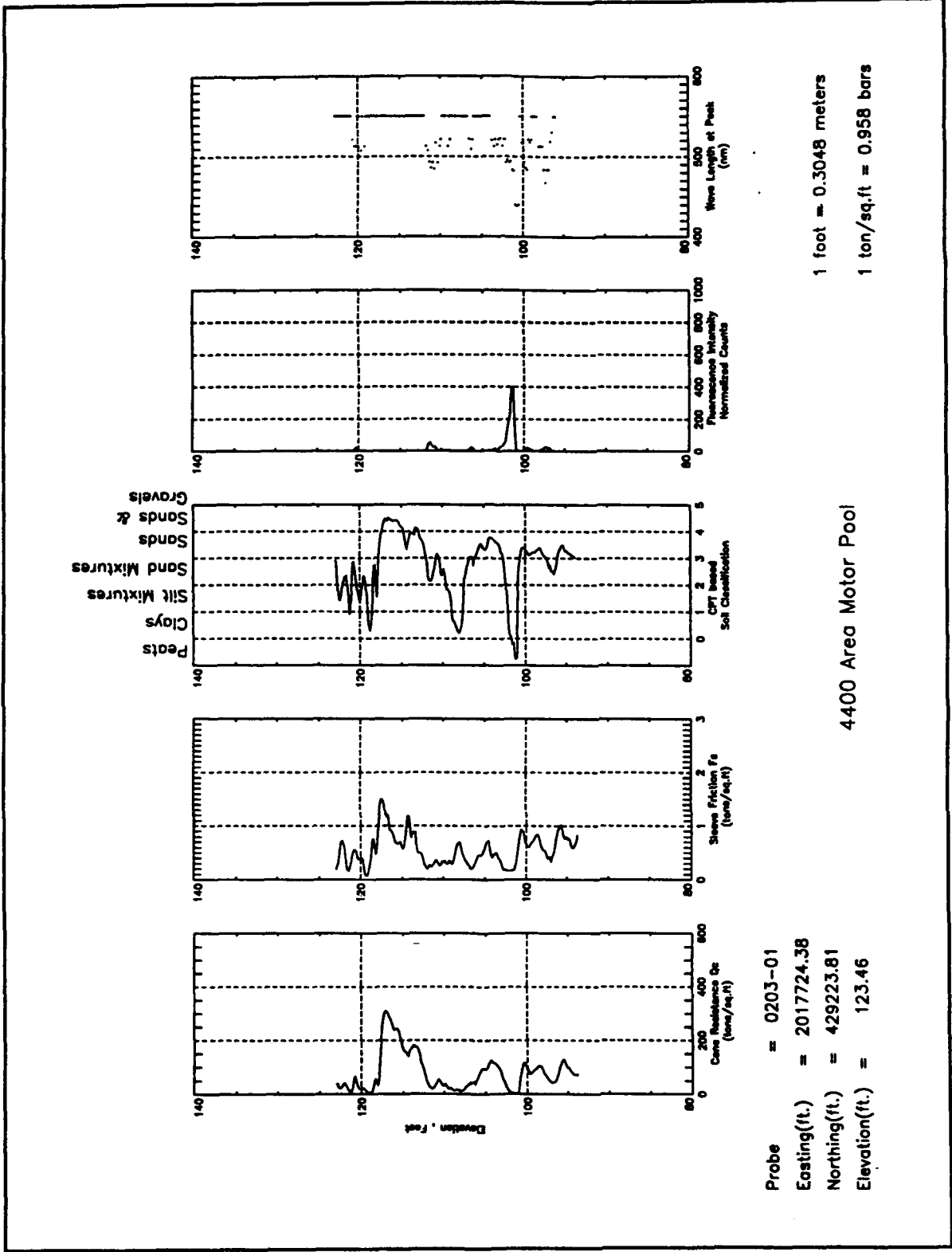

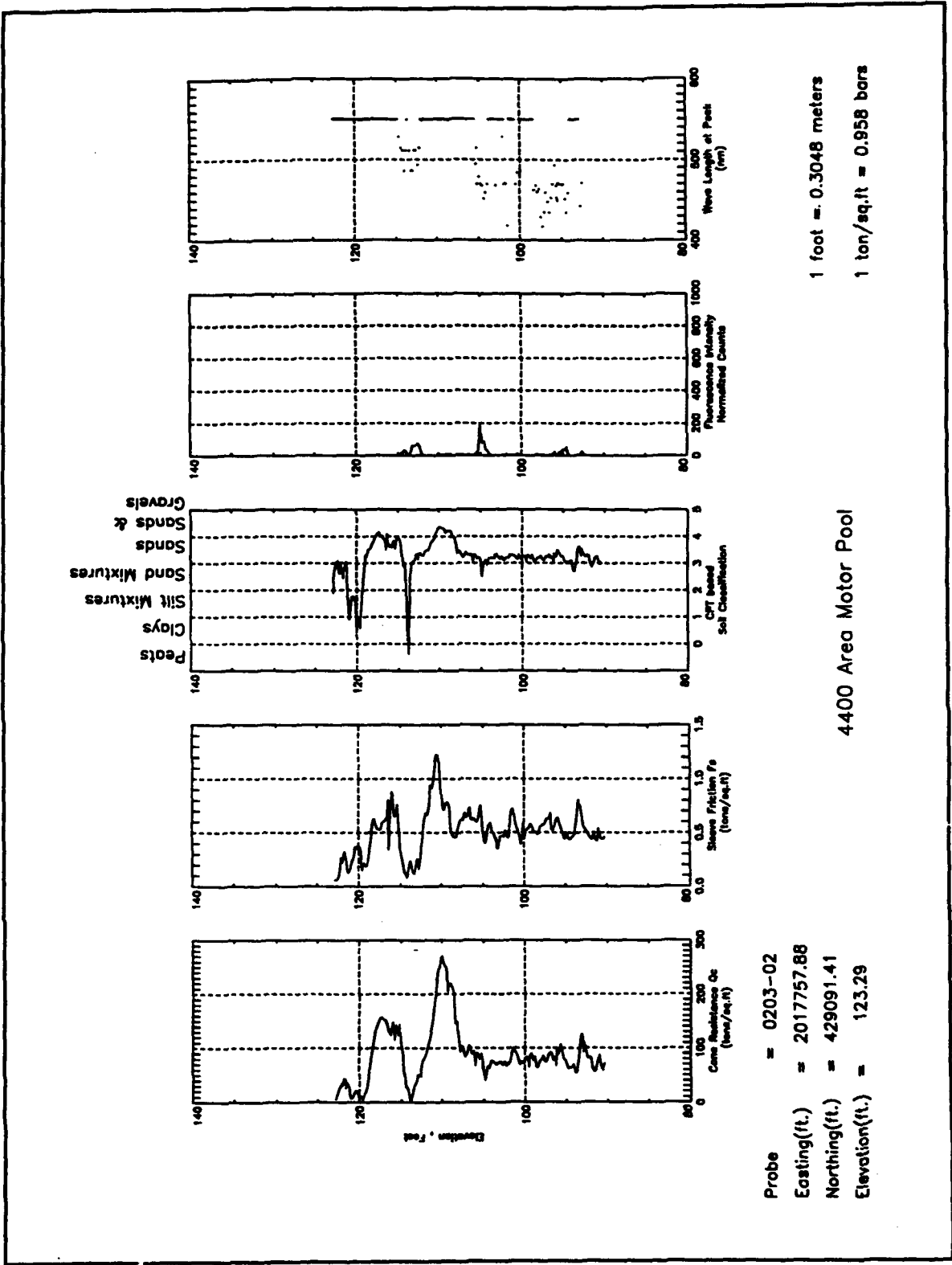

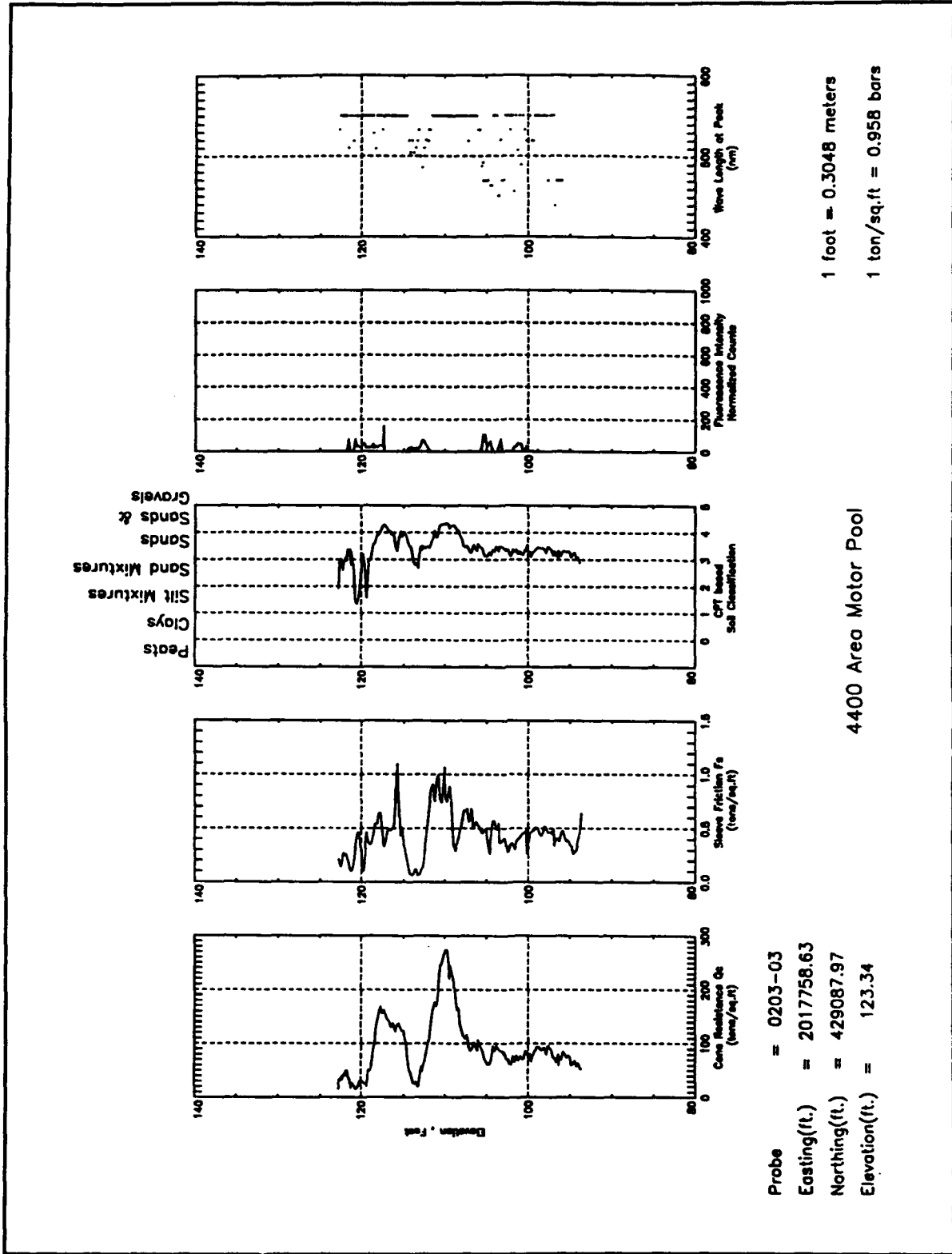

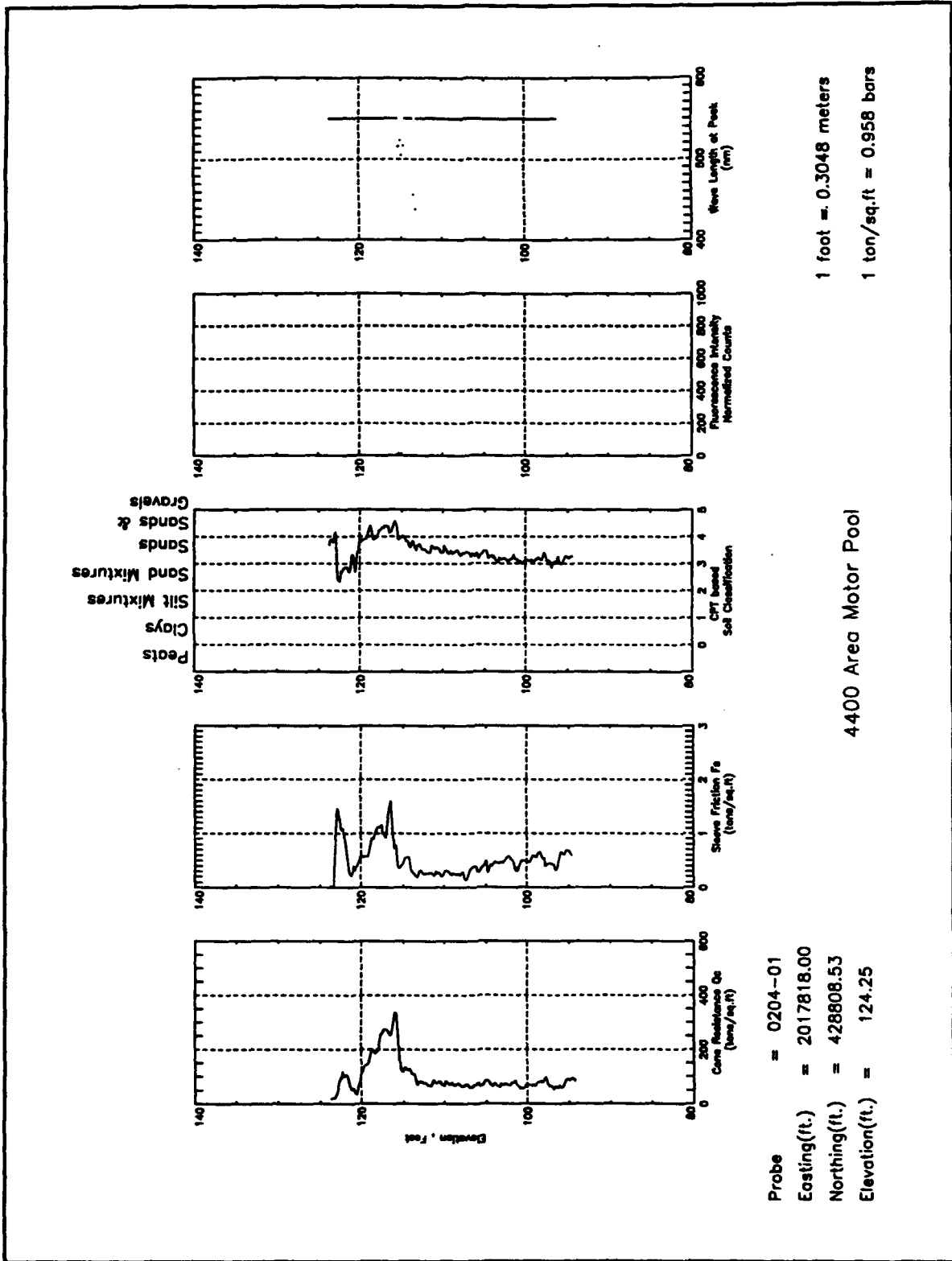

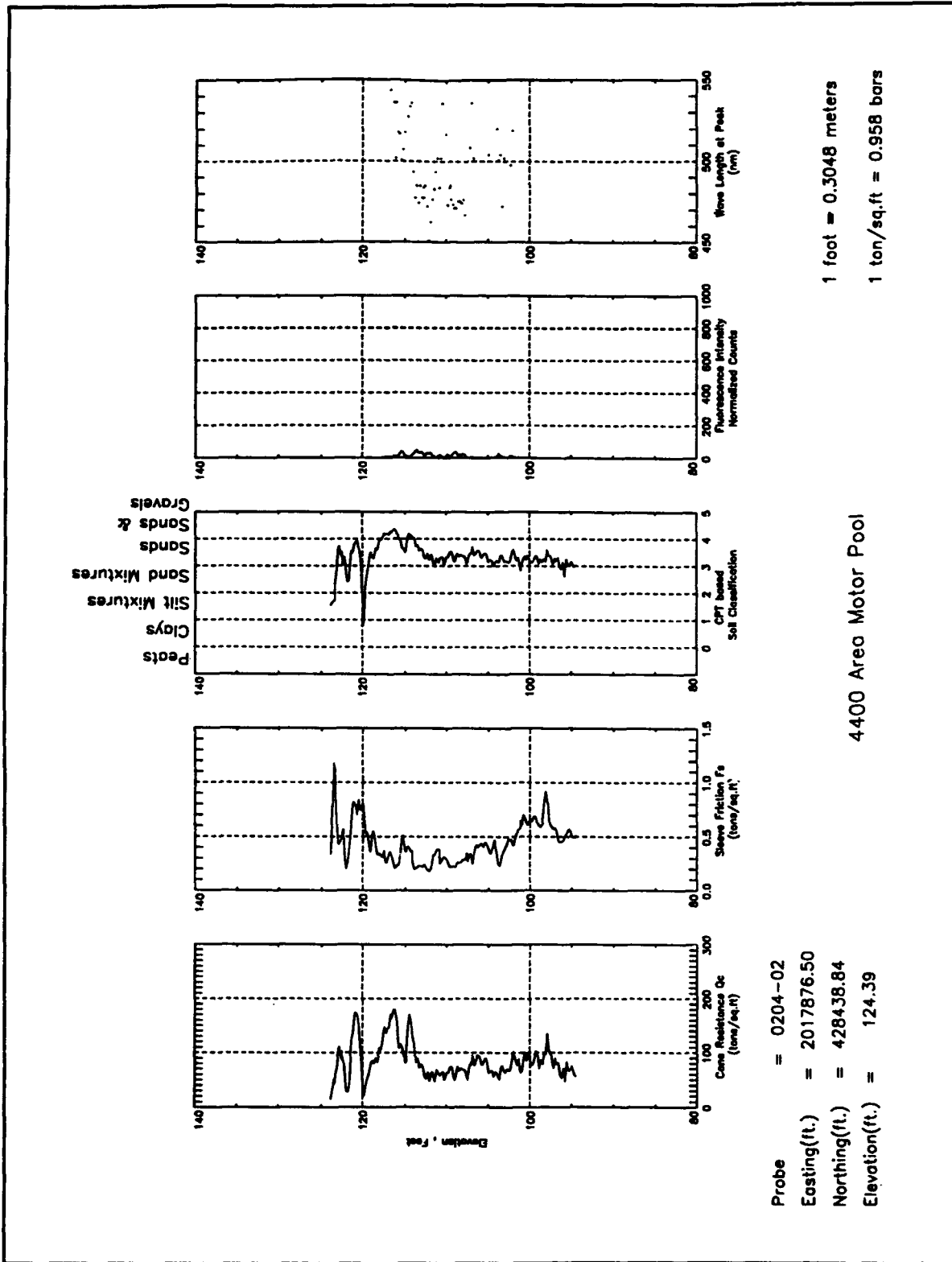

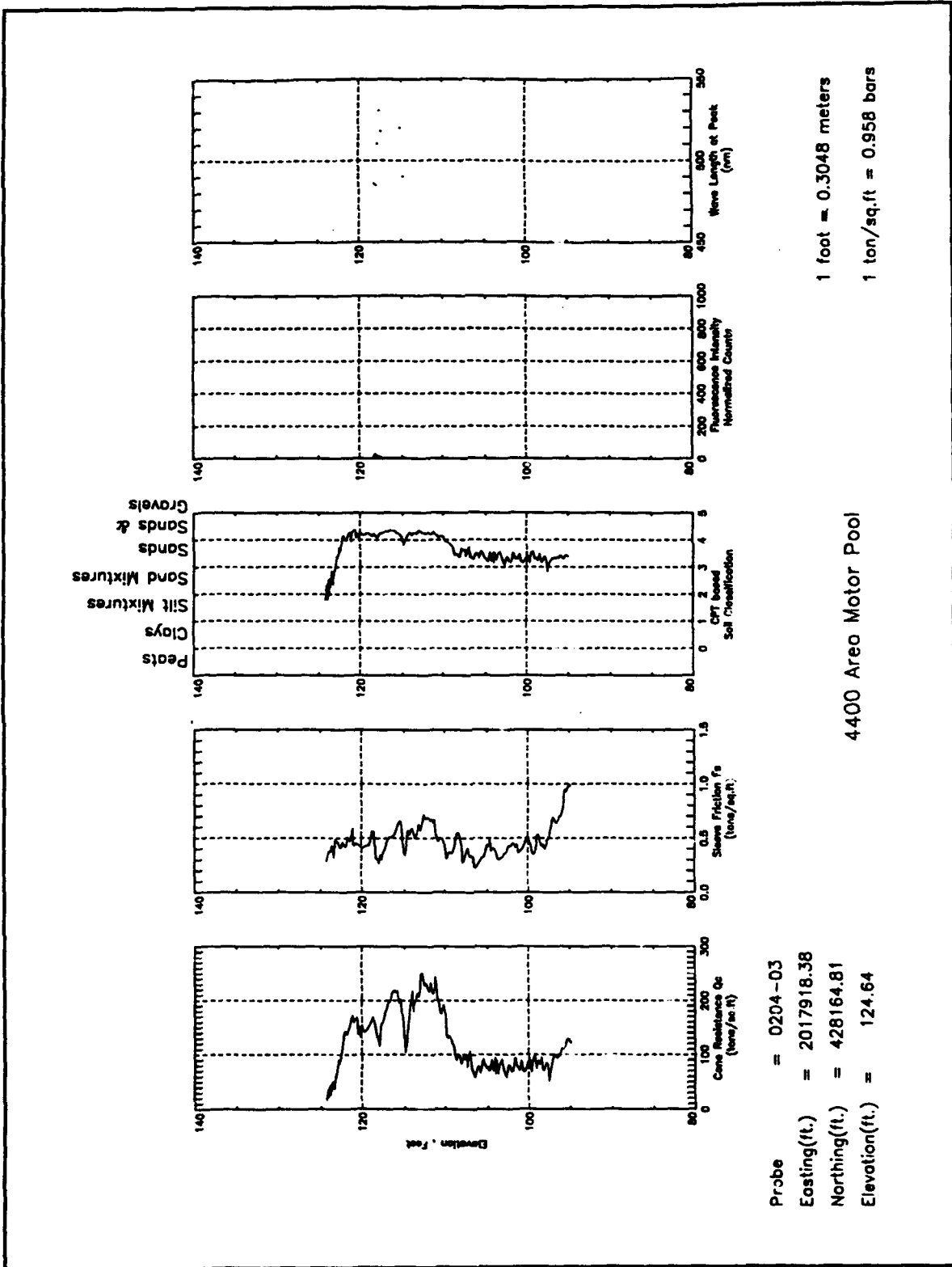

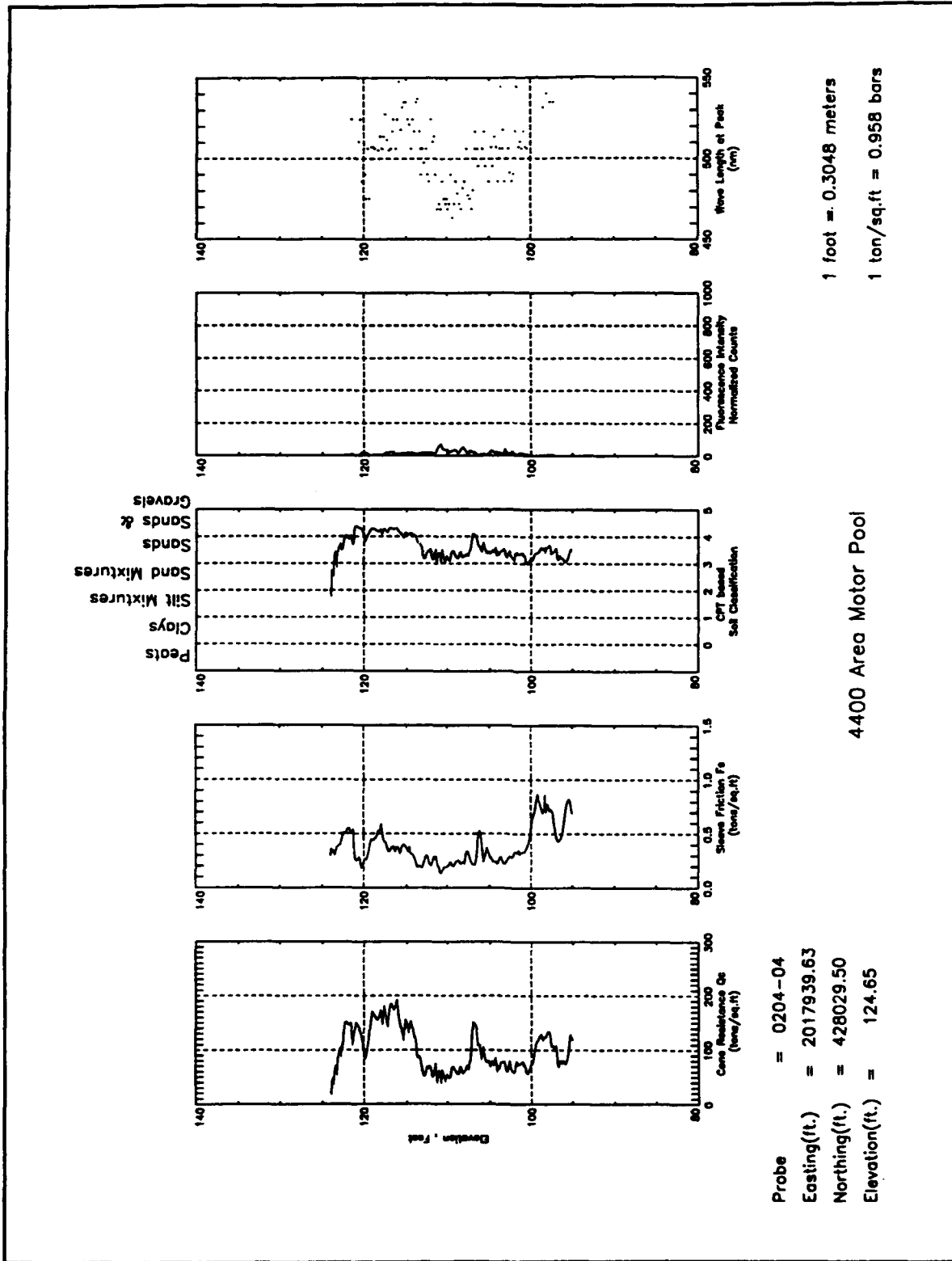

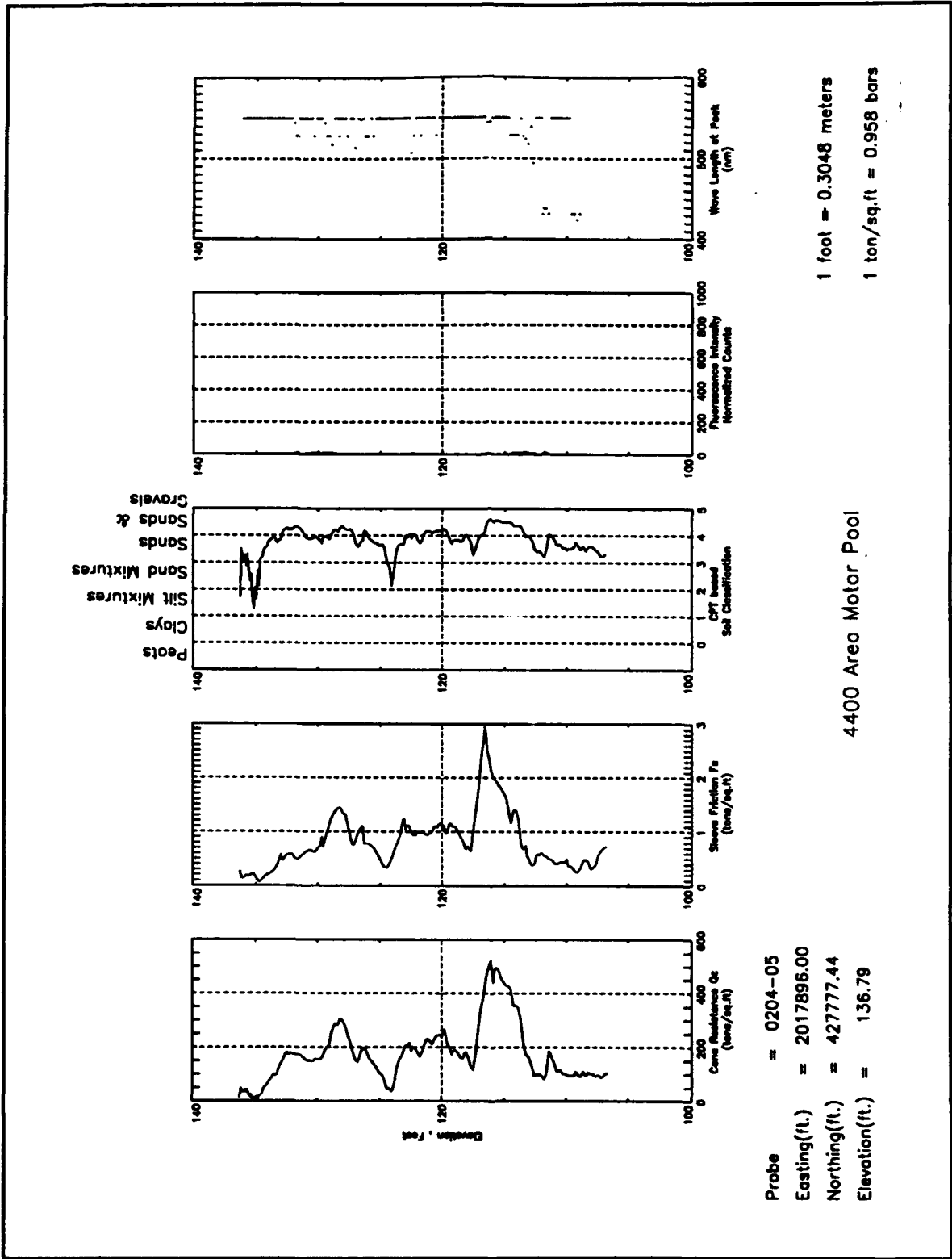

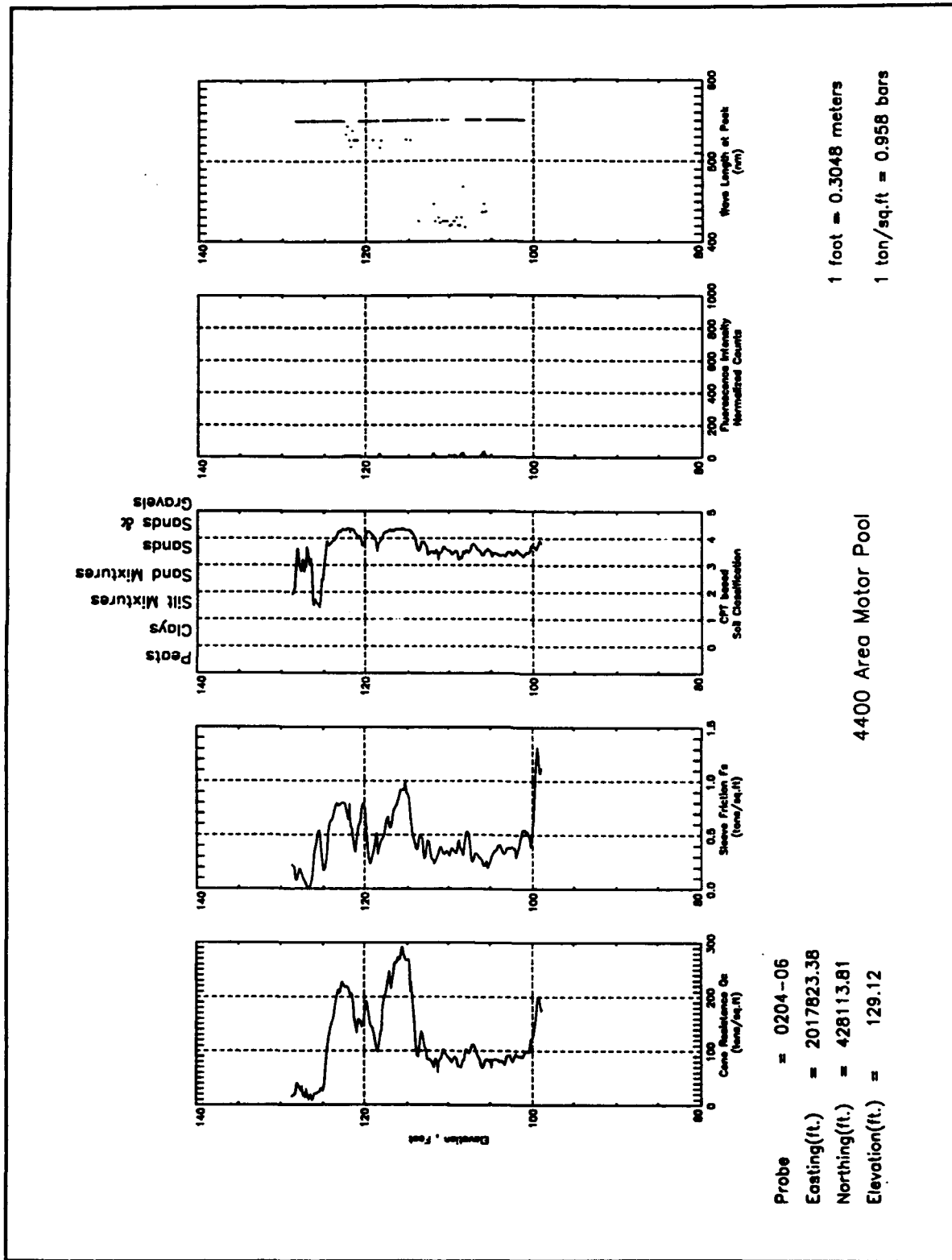

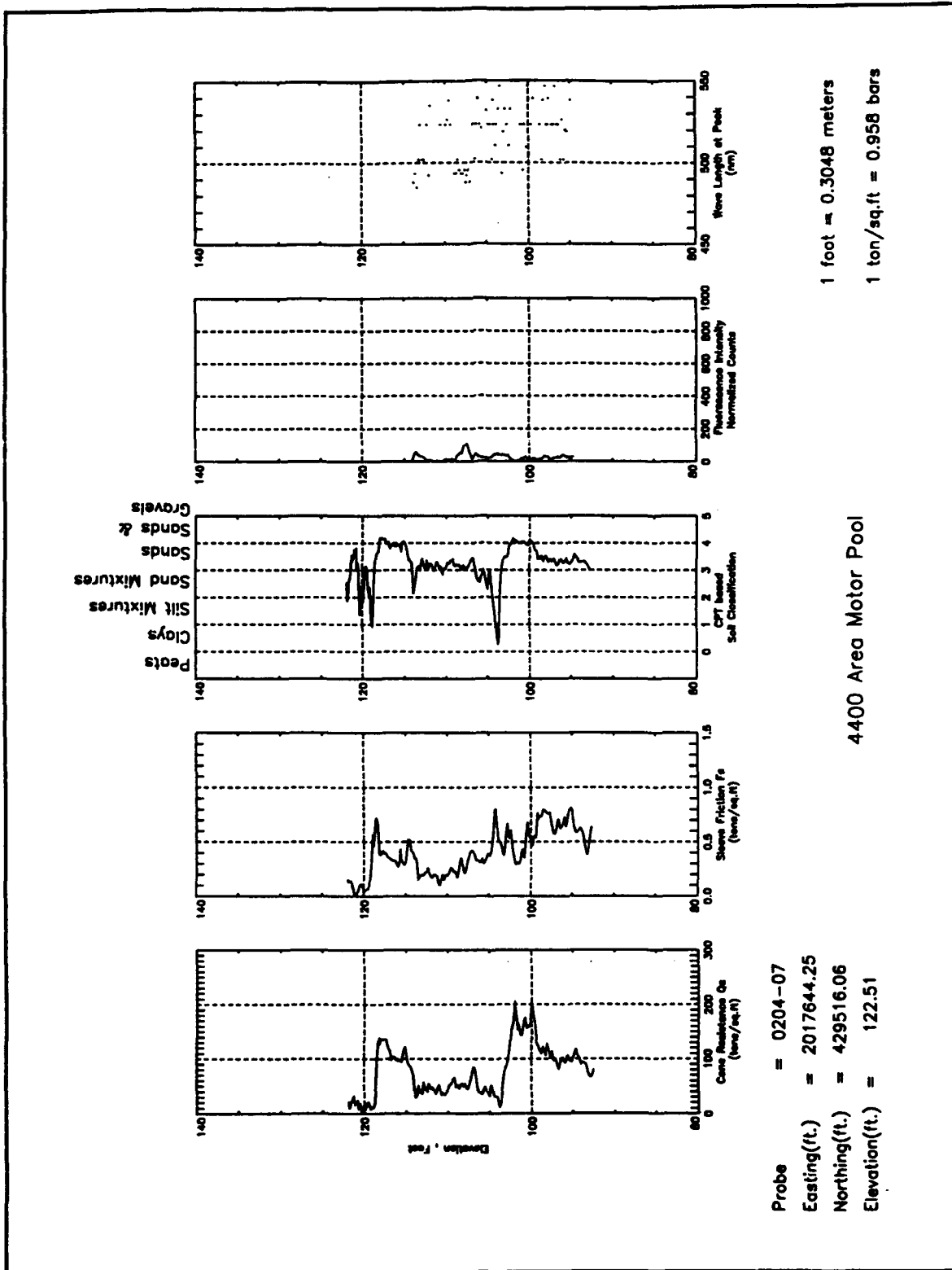

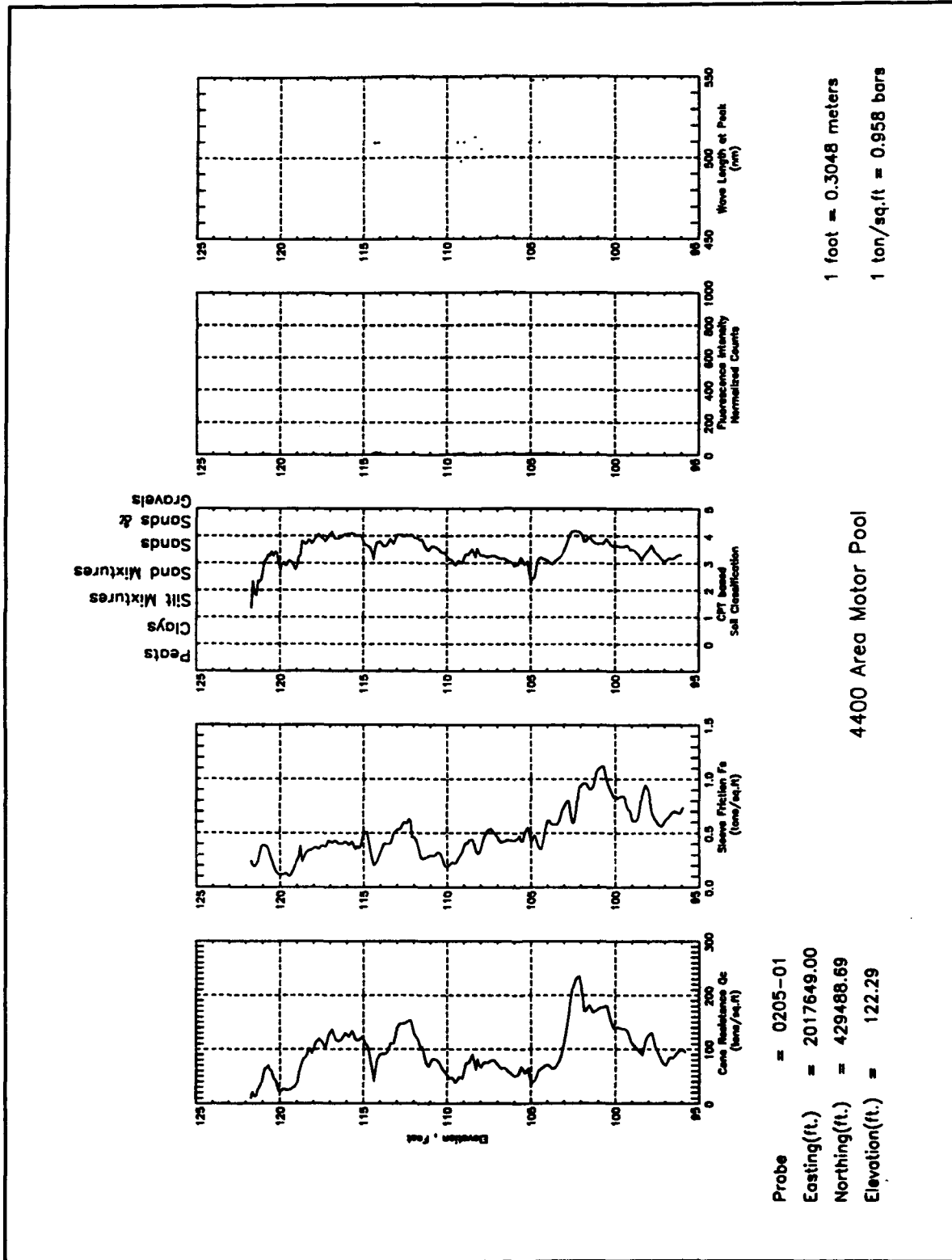

1 foot = 0.3048 meters
 1 ton/sq.ft = 0.958 bars

4400 Area Motor Pool

Probe = 0205-01
 Easting(ft.) = 2017649.00
 Northing(ft.) = 429488.69
 Elevation(ft.) = 122.29

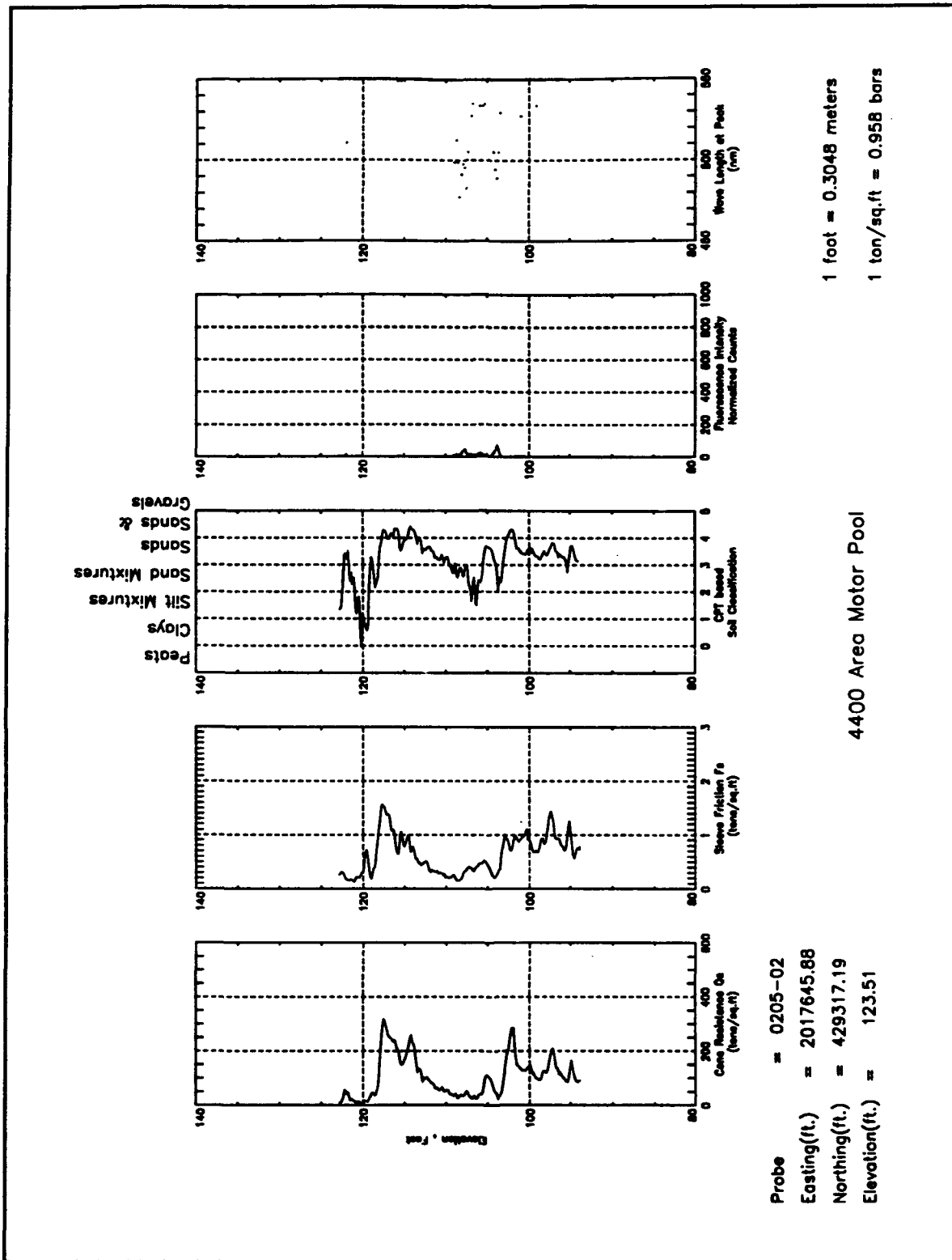

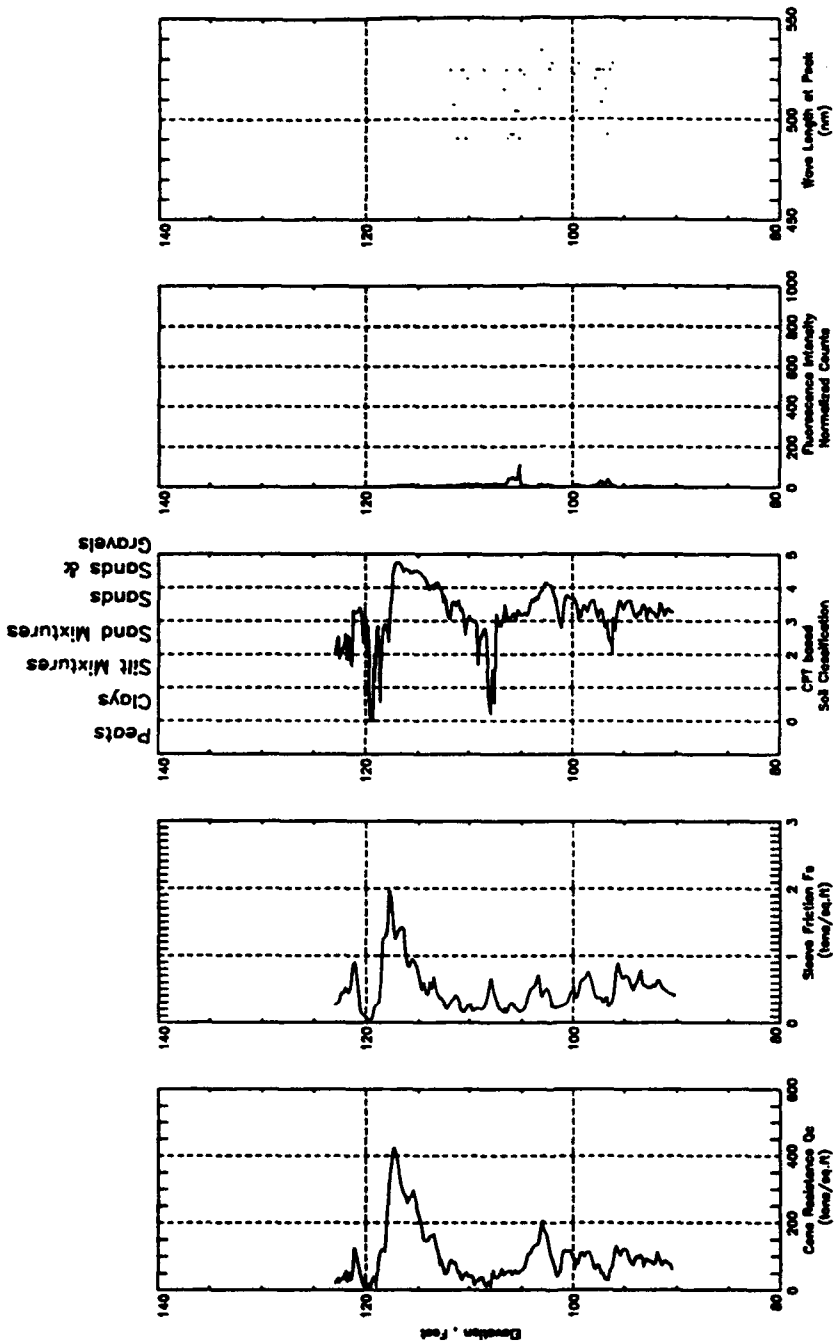

Probe = 0205-03
 Easting(ft.) = 2017719.50
 Northing(ft.) = 429222.66
 Elevation(ft.) = 123.31

4400 Area Motor Pool

1 foot = 0.3048 meters
 1 ton/sq.ft = 0.958 bars

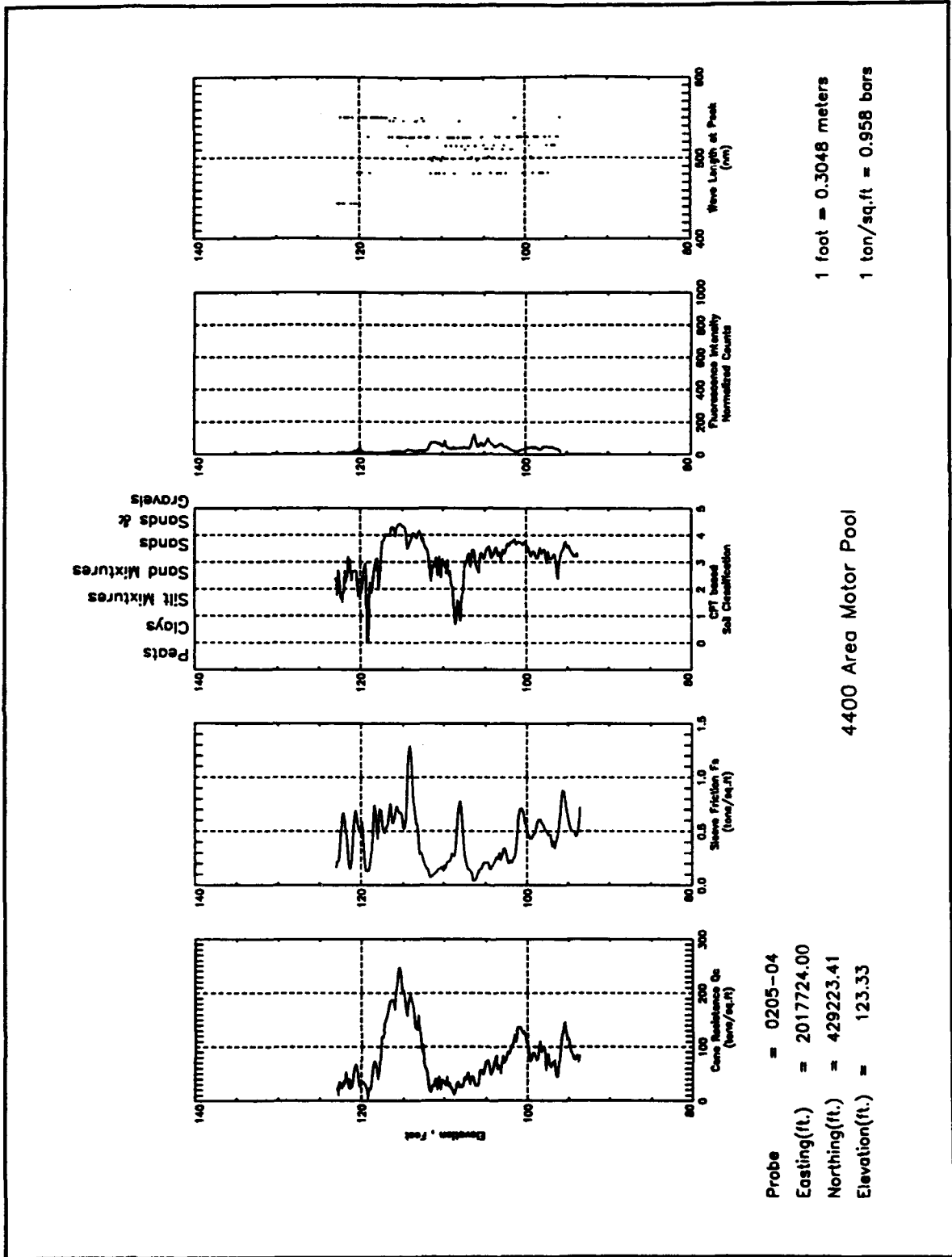

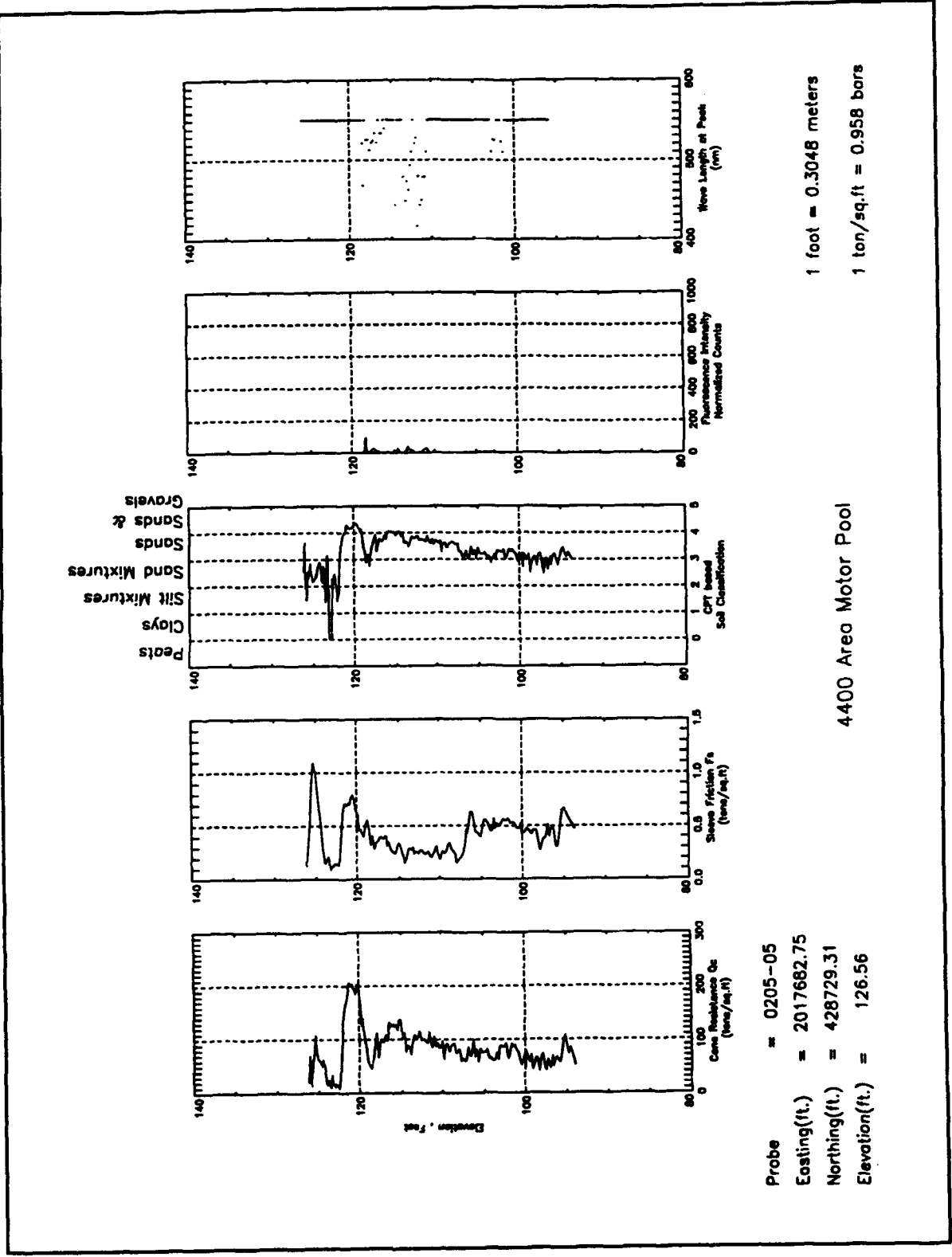

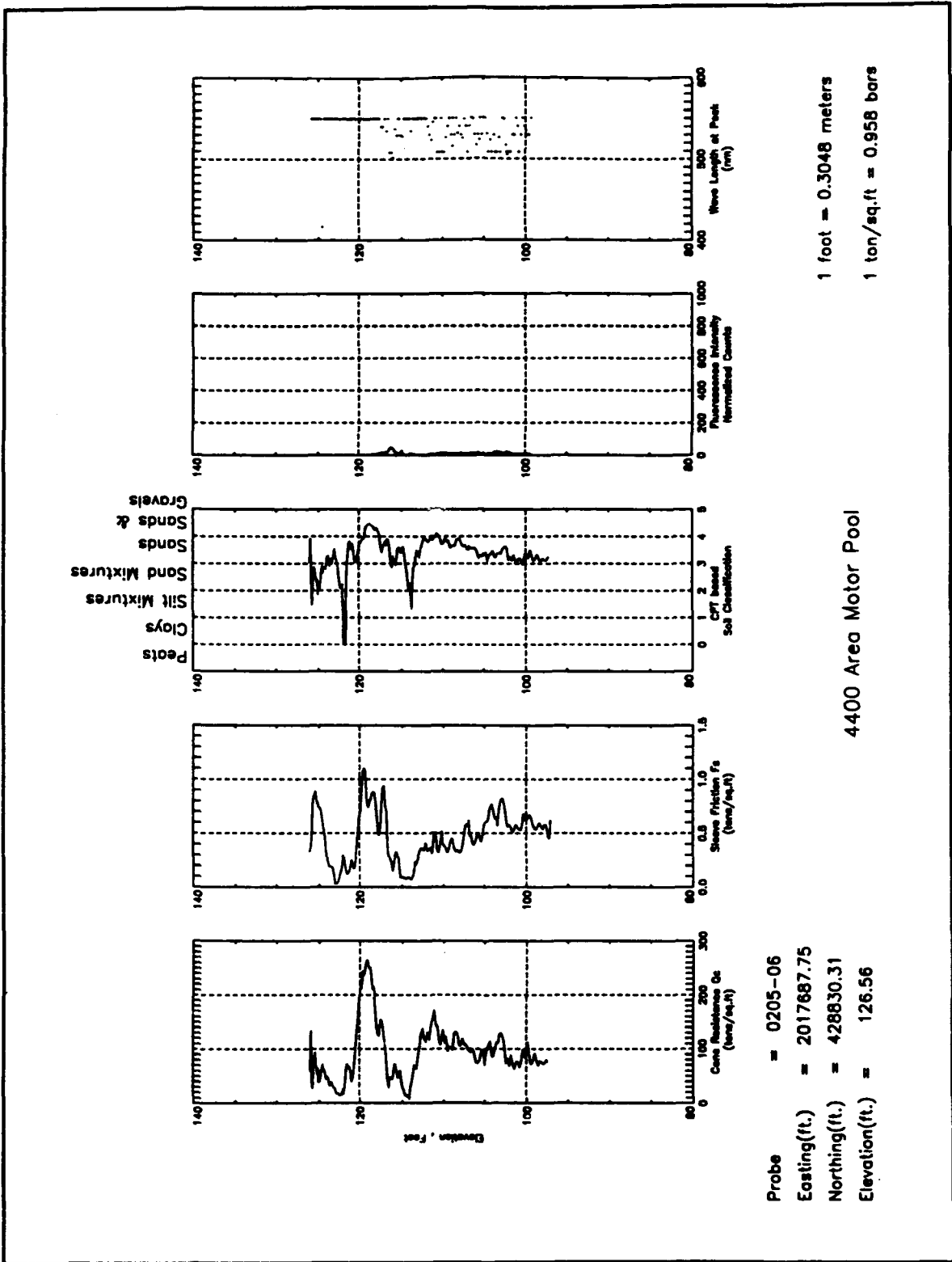

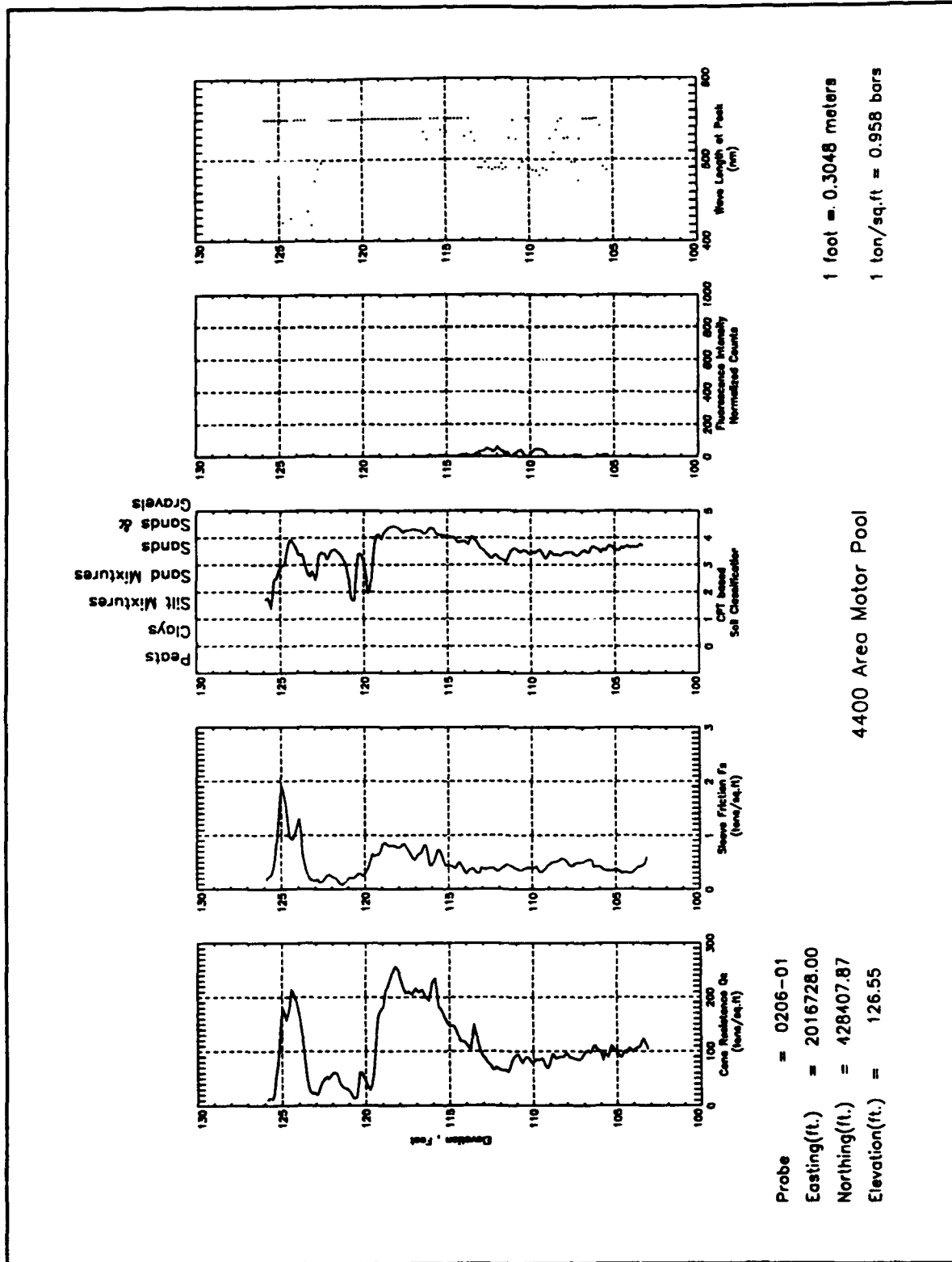

Appendix E

5252 Boiler Plant

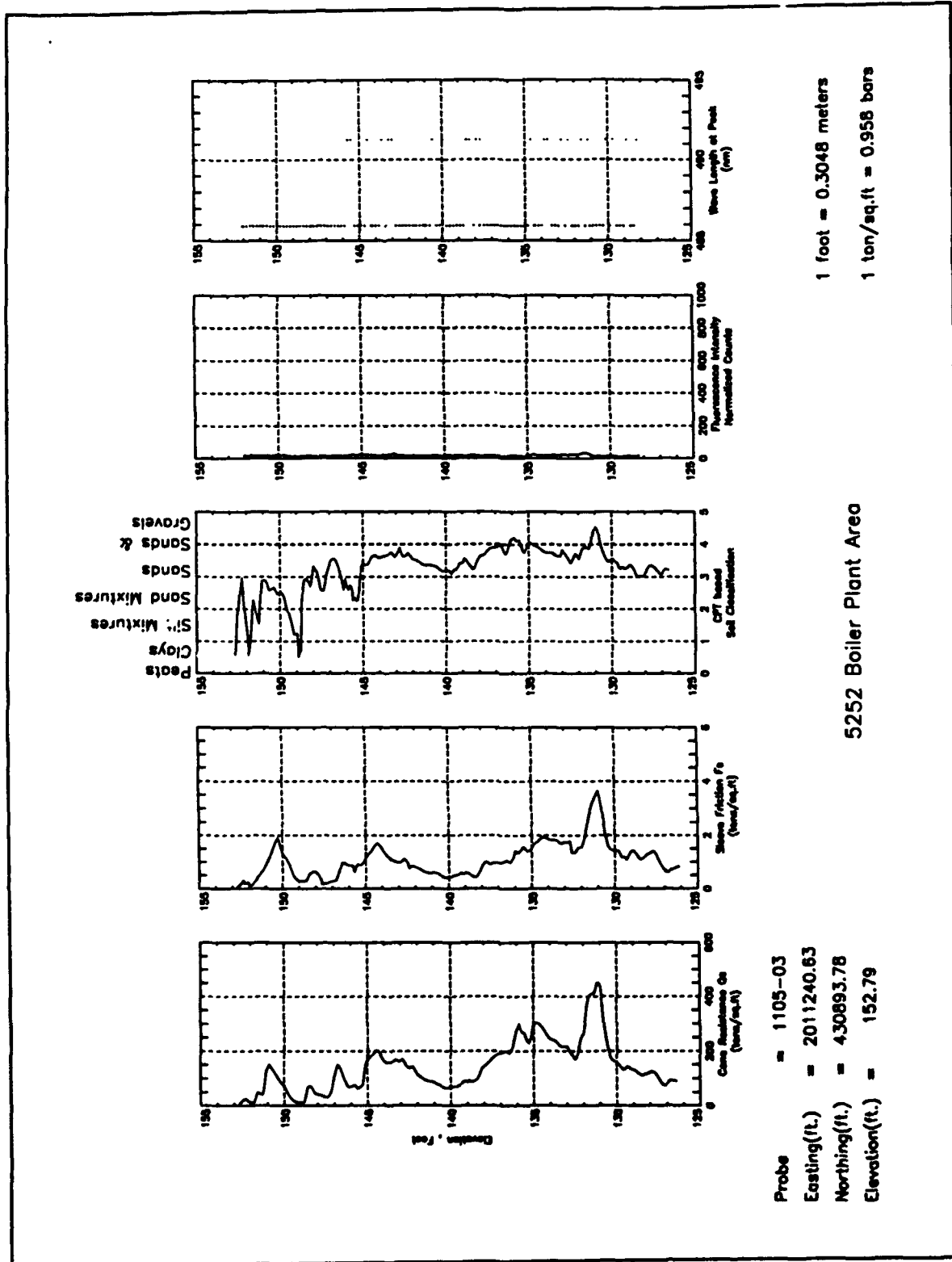

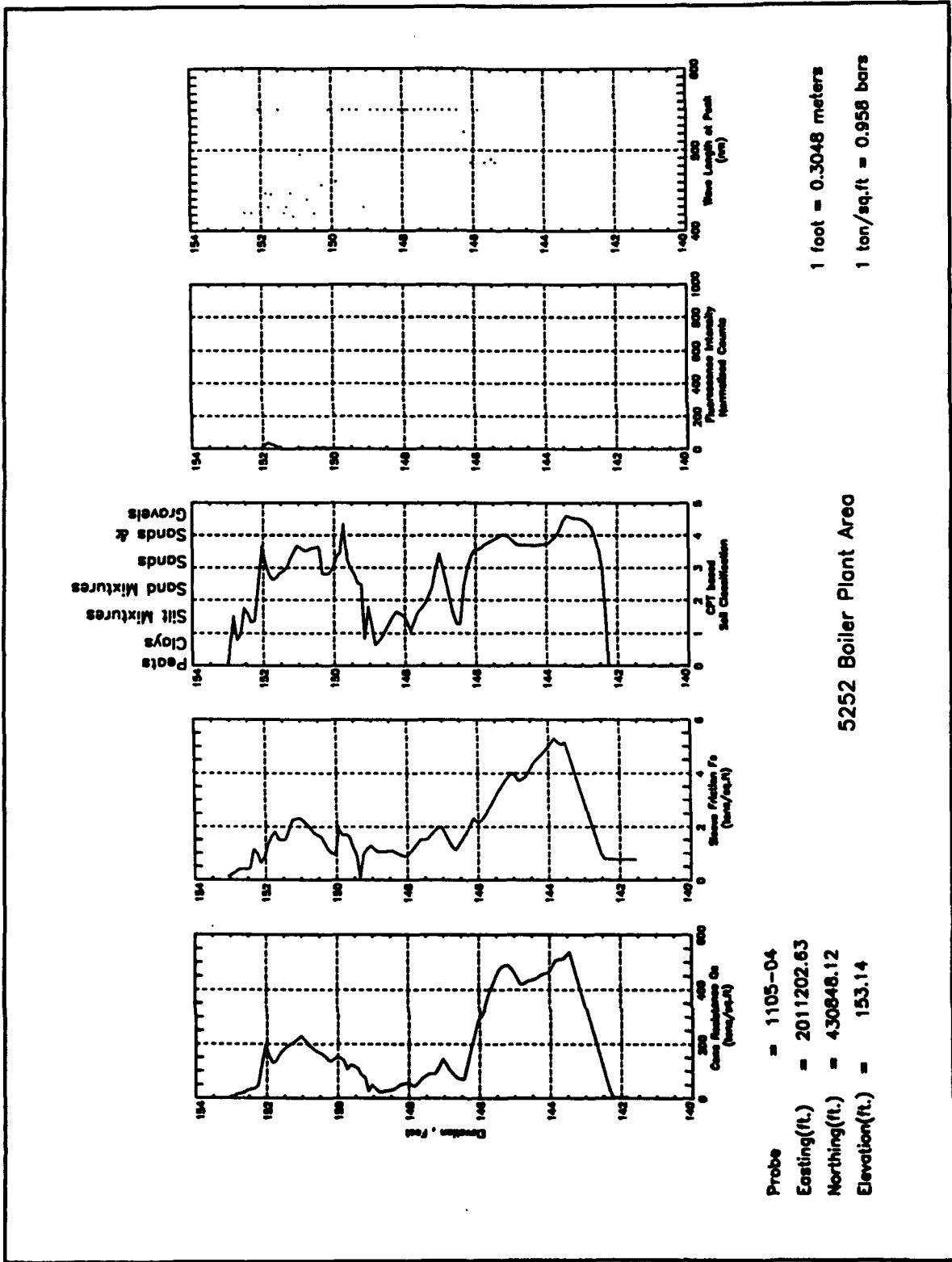

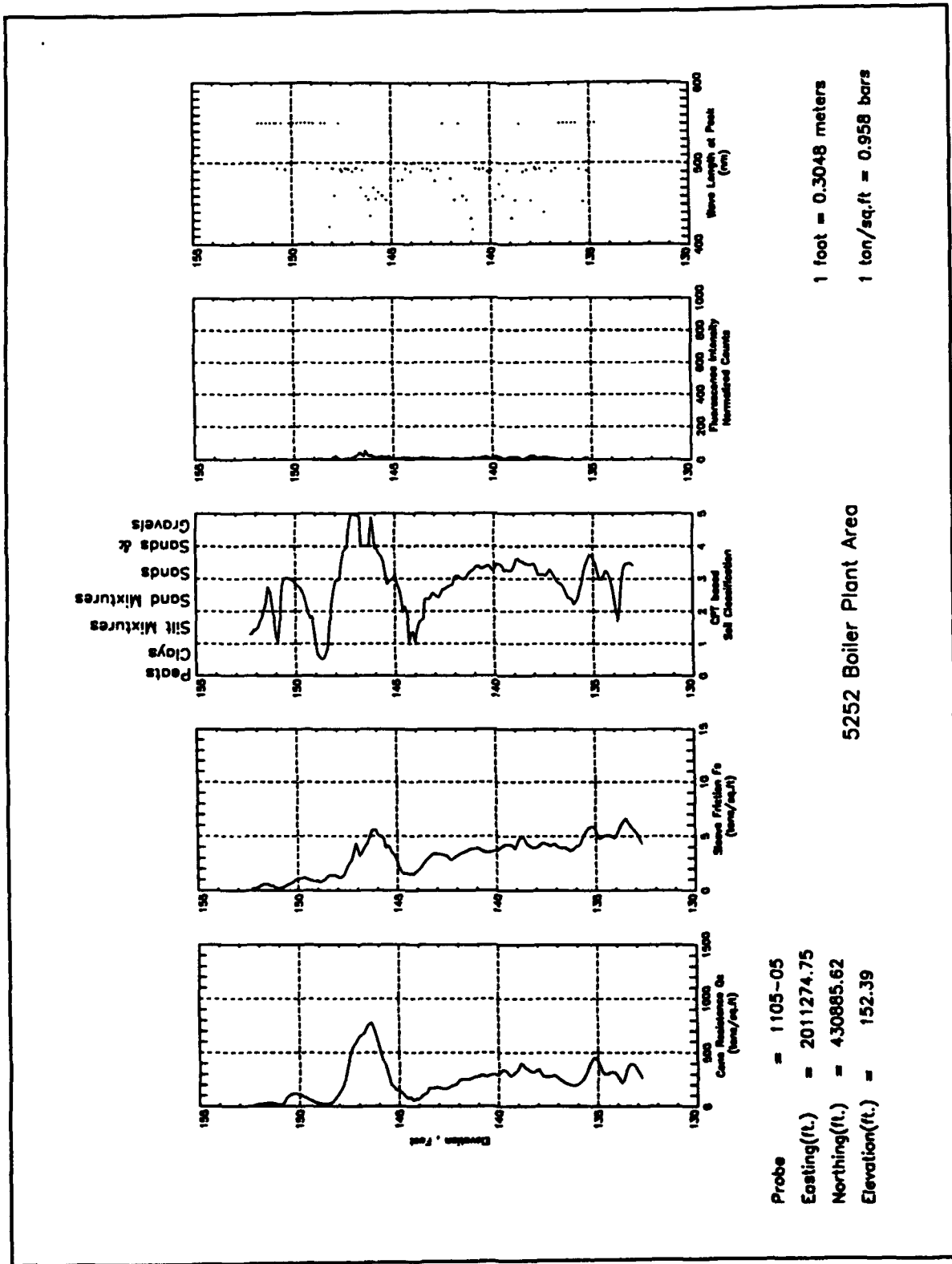

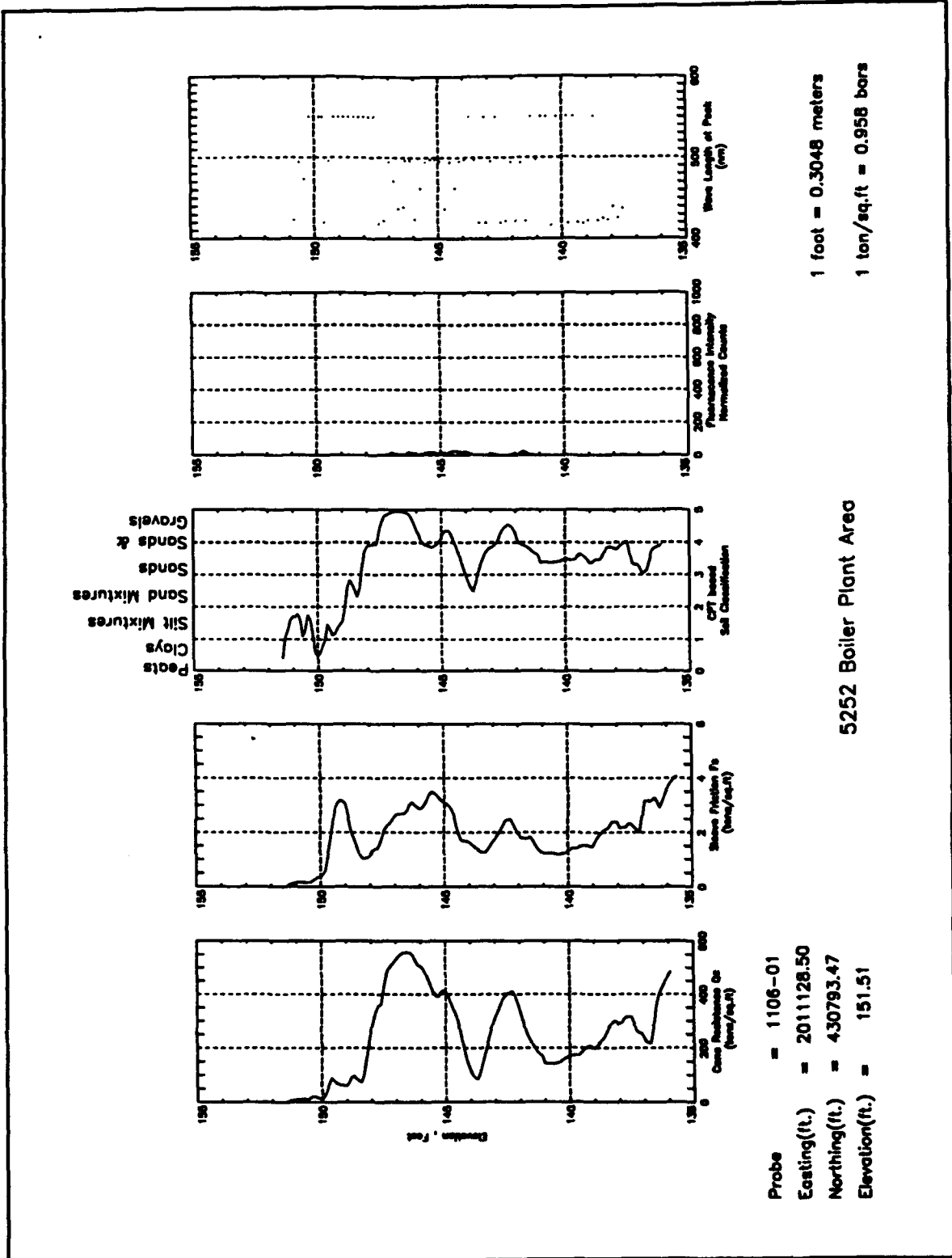

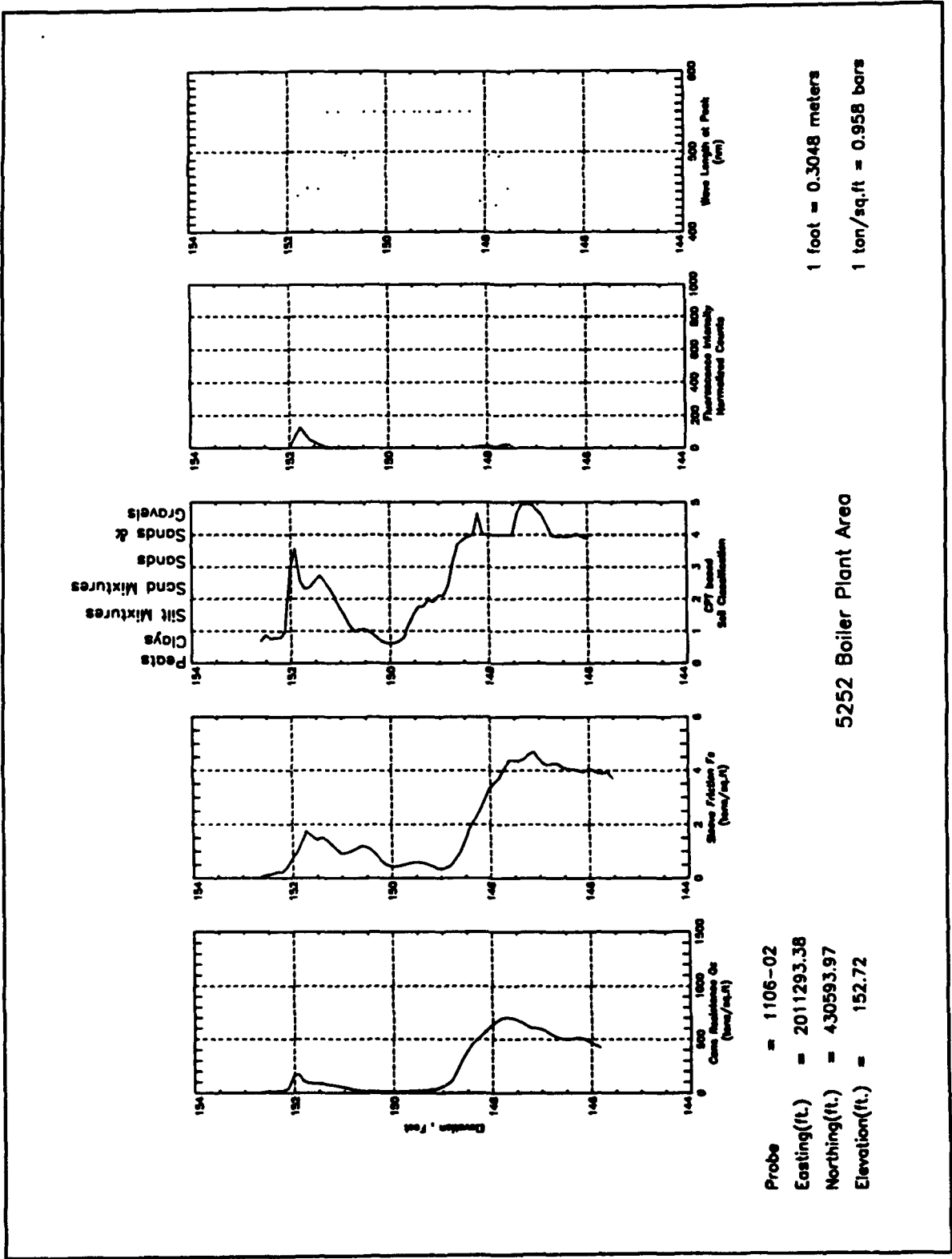

Appendix F
5326 Post Boiler Plant Area
(Laundry)

**Verification Sample Information
5326 Post Boiler Plant Area**

Sample No.	29299	29282	29281	29518
Type	Water	Soil	Soil	Soil
Lab Method	418.1/415.1	418.1/415.10	418.1/415.1	8270
TRPH, ppm	<2.2	<25	<25	
Other ppm	34(TOC)	1381(TOC)	2778(TOC)	PAH-Table 9
Easting, ft	2012524	2012544	2012524	2012524
Northing, ft	434197	434232	434197	434197
Elevation Range ft MSL	109-110	138-139	109.2-110.2	109.2-110.2
Sample Fluoresced?	NO	NO	YES	YES
Maximum Intensity counts	0	0	6	6
Peak Wavelength (nanometers)	585	585	550	550
Nearest Probe	1117-02	0208-05	1117-02	1117-02
Easting, ft	2012522.1	2012542.3	2012522.1	2012522.1
Northing, ft	434195.6	434230.5	434195.6	434195.6
Offset from Sample, ft	2	2	2	2
Soil Classification at Sample Elevation	Clay	Silt	Clay	Clay
Intensity Range counts	10-25	0	0-10	0-10
Peak Wavelength, nm	490	585	550	550

TRPH = Total Recoverable Petroleum Hydrocarbons.
 PAH = Polynuclear Aromatic Hydrocarbons.
 TOC = Total Organic Carbon.
 OG = Oil and Grease.
 ppm = parts per million.
 Lab Method = USEPA SW-846, 1984.

(Sheet 1 of 3)

**Verification Sample Information
5326 Post Boiler Plant Area (Continued)**

Sample No.	29296	29297	29298	29295
Type	Water	Water	Water	Water
Lab Method	418.1/415.1	418.1/415.1	418.1/415.1	418.1/415.1
TRPH, ppm	0.7	1.5	<2.4	<2.7
Other, ppm	27(TOC)	43(TOC)	45(TOC)	479.5(TOC)
Easting, ft	2012544	2012544	2012544	2012524
Northing, ft	434232	434232	434232	434197
Elevation Range ft MSL	119-120	119-120	119-120	109-110
Sample Fluoresced?	YES	YES	YES	NO
Maximum Intensity counts	1	1	1	0
Peak Wavelength, nm	576	576	576	585
Nearest Probe	0208-05	0208-05	0208-05	1117-02
Easting, ft	2012542.8	2012542.8	2012542.8	2012522.1
Northing, ft	434230.5	434230.5	434230.5	434195.6
Offset from Sample, ft	2	2	2	2
Soil Classification at Sample Elevation	Sand	Sand	Sand	Clay
Intensity Range counts	0	0	0	0-10
Peak Wavelength, nm	580	580	580	550

TRPH = Total Recoverable Petroleum Hydrocarbons.
 PAH = Polynuclear Aromatic Hydrocarbons.
 TOC = Total Organic Carbon.
 OG = Oil and Grease.
 ppm = parts per million.
 Lab Method = USEPA SW-846, 1984.

(Sheet 2 of 3)

Verification Sample Information 5326 Post Boiler Plant Area (Concluded)				
Sample No.	29519			
Type	Soil			
Lab Method	8270			
TRPH, ppm				
Other, ppm	PAH-Table 9			
Easting, ft	2012544			
Northing, ft	434232			
Elevation Range ft MSL	138-139			
Sample Fluoresced?	NO			
Maximum Intensity counts	0			
Peak Wavelength, nm	580			
Nearest Probe	0208-05			
Easting, ft	2012542.8			
Northing, ft	434230.5			
Offset from Sample ft	2			
Soil Classification at Sample Elevation	Silt			
Intensity Range counts	0			
Peak Wavelength, nm	580			
TRPH = Total Recoverable Petroleum Hydrocarbons. PAH = Polynuclear Aromatic Hydrocarbons. TOC = Total Organic Carbon. OG = Oil and Grease. ppm = parts per million. Lab Method = USEPA SW-846, 1984.				
<i>(Sheet 3 of 3)</i>				

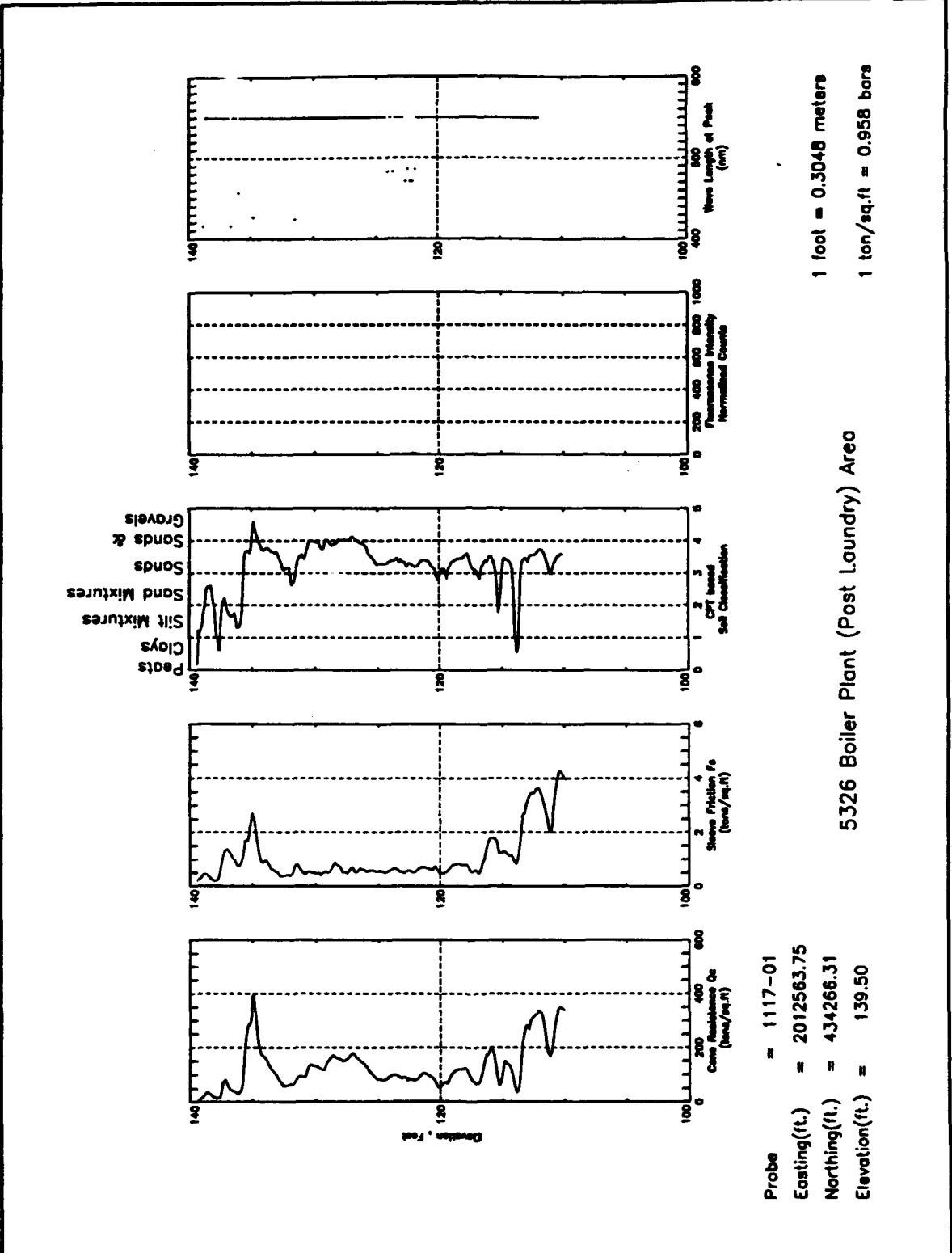

Probe = 1117-01
 Easting(ft.) = 2012563.75
 Northing(ft.) = 434266.31
 Elevation(ft.) = 139.50

5326 Boiler Plant (Post Laundry) Area

1 foot = 0.3048 meters
 1 ton/sq.ft = 0.958 bars

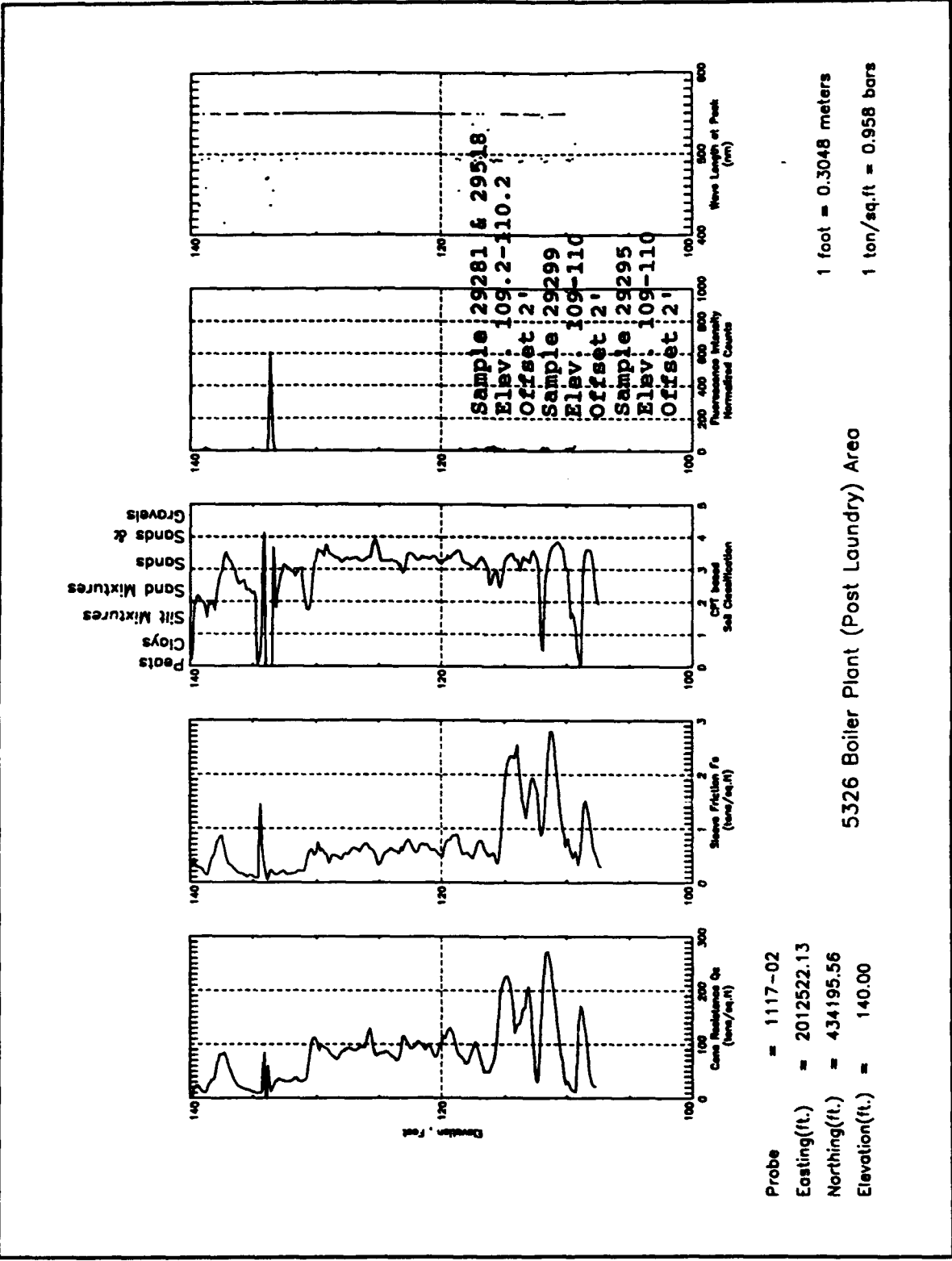

Probe = 1117-02
 Easting(ft.) = 2012522.13
 Northing(ft.) = 434195.56
 Elevation(ft.) = 140.00

5326 Boiler Plant (Post Laundry) Area

1 foot = 0.3048 meters
 1 ton/sq.ft = 0.958 bars

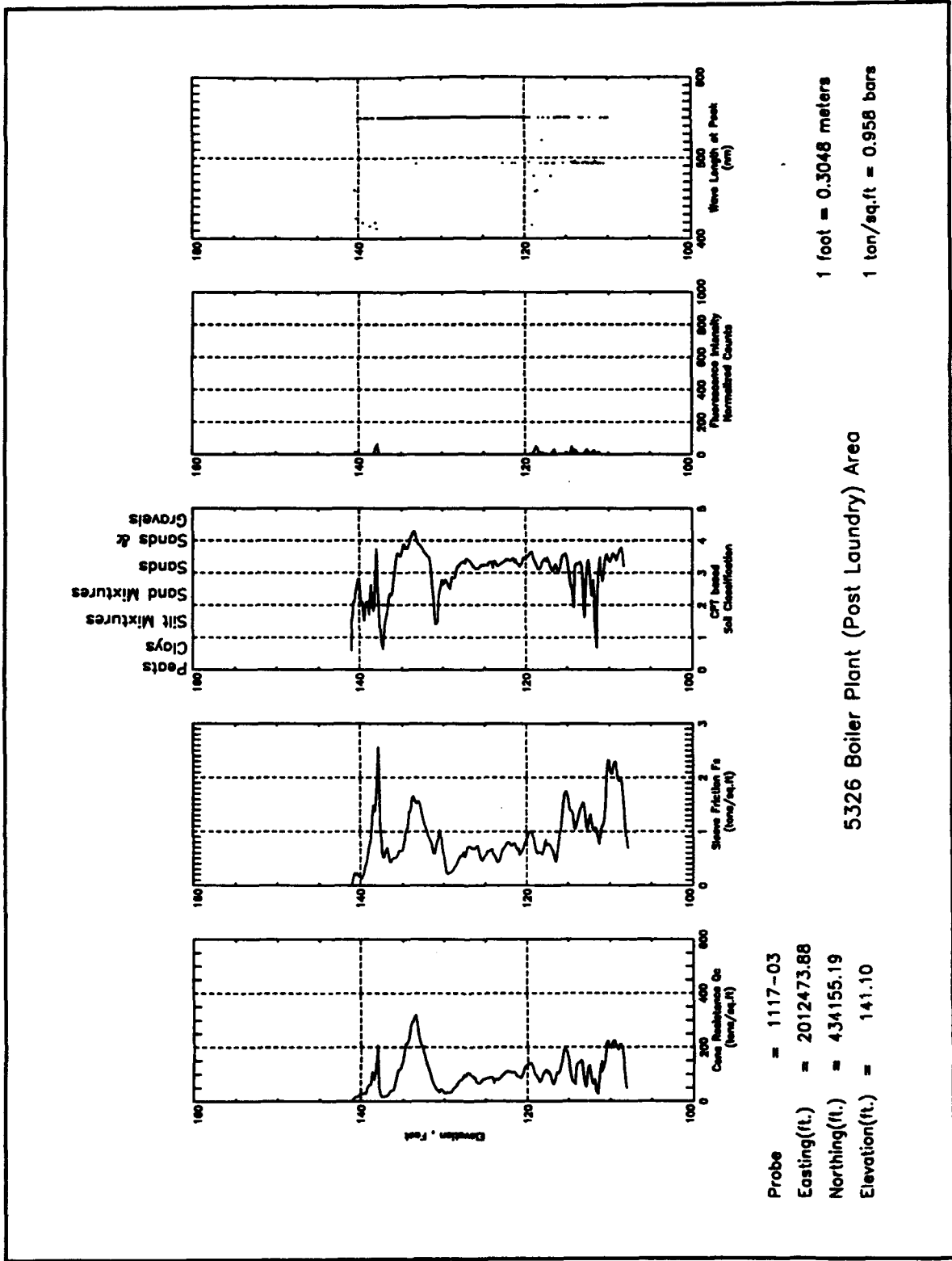

Probe = 1117-03
 Easting(ft.) = 2012473.88
 Northing(ft.) = 434155.19
 Elevation(ft.) = 141.10

1 foot = 0.3048 meters
 1 ton/sq.ft = 0.958 bars

5326 Boiler Plant (Post Laundry) Area

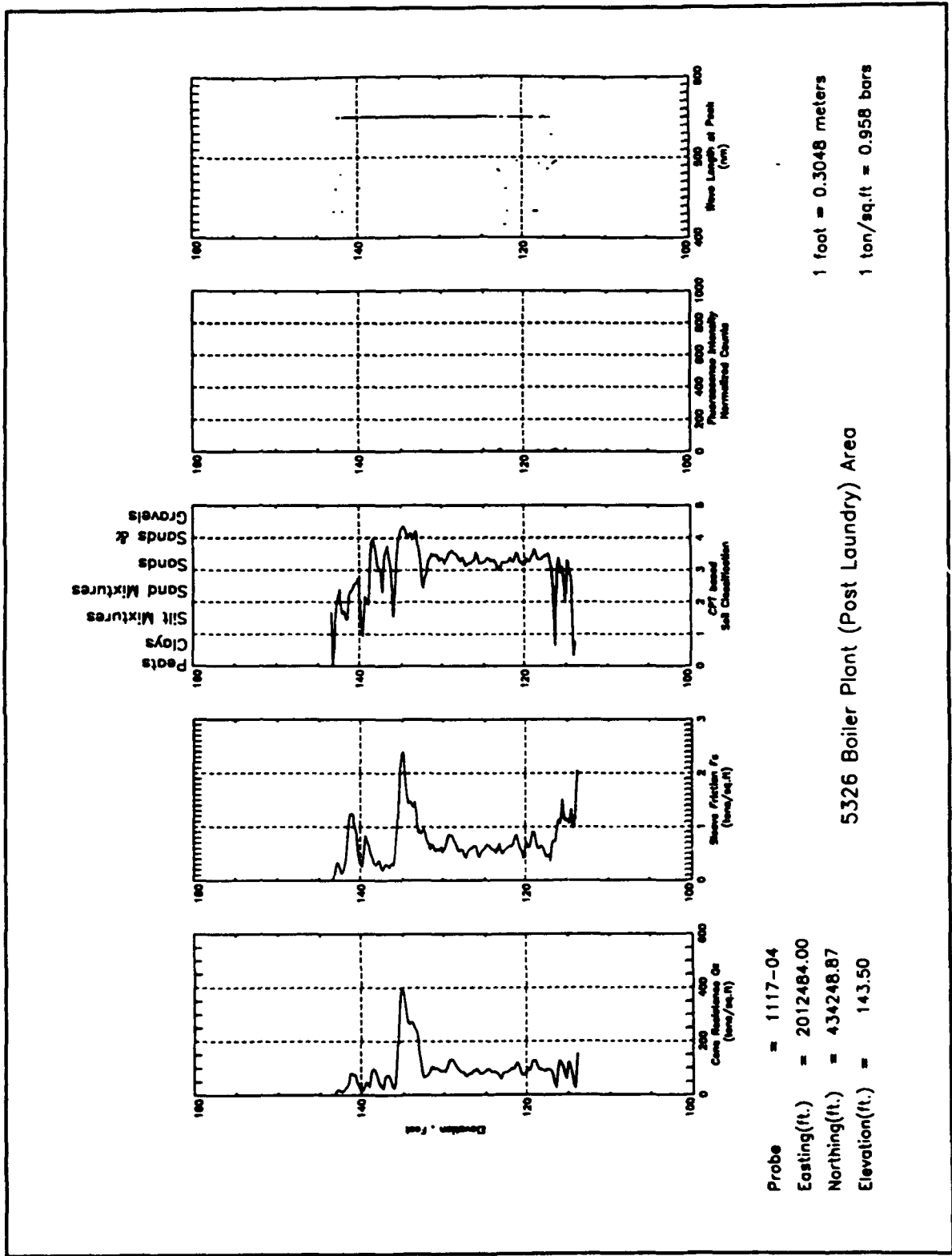

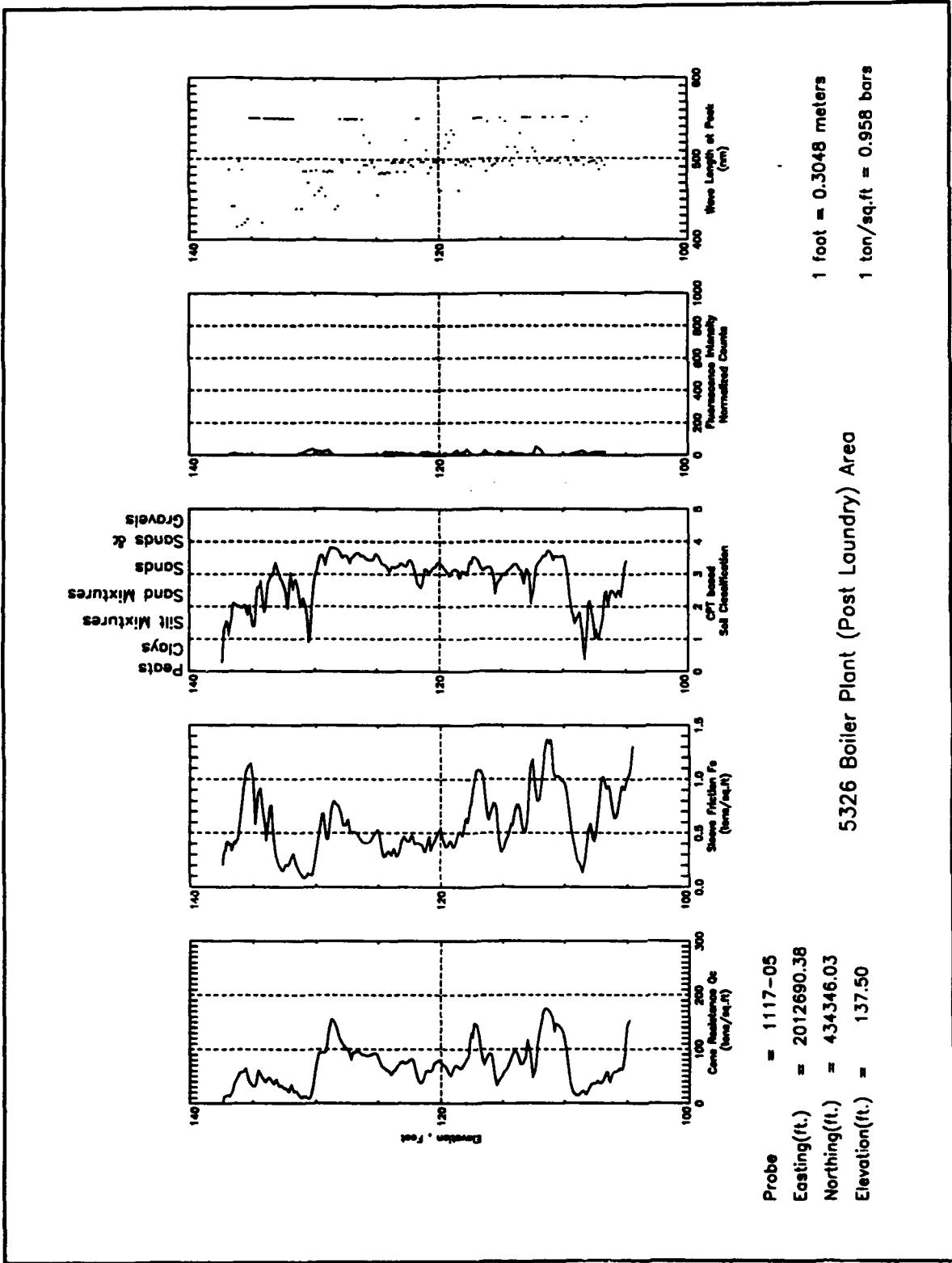

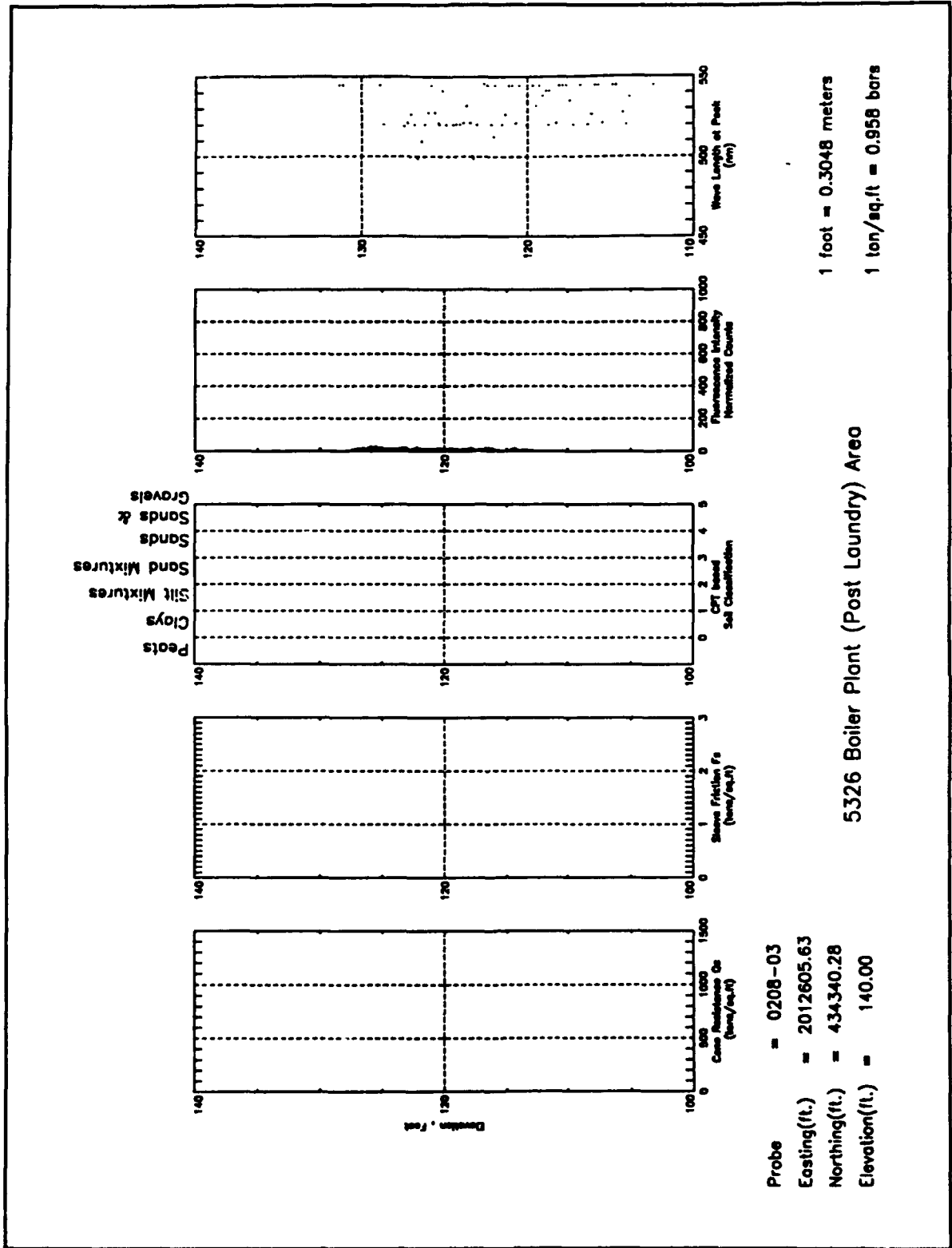

Probe = 0208-03
 Easting(ft.) = 2012605.63
 Northing(ft.) = 434340.28
 Elevation(ft.) = 140.00

5326 Boiler Plant (Post Laundry) Area

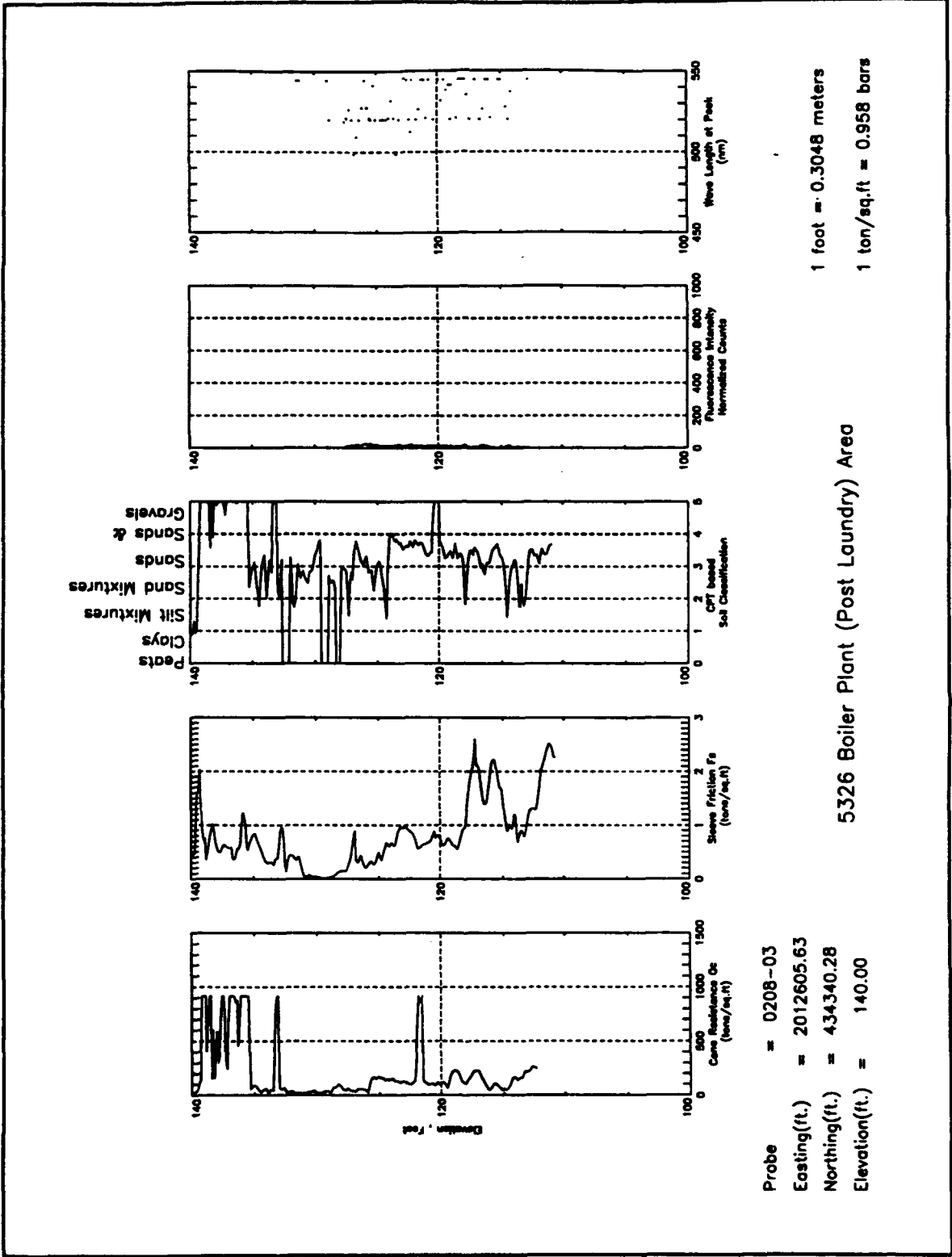

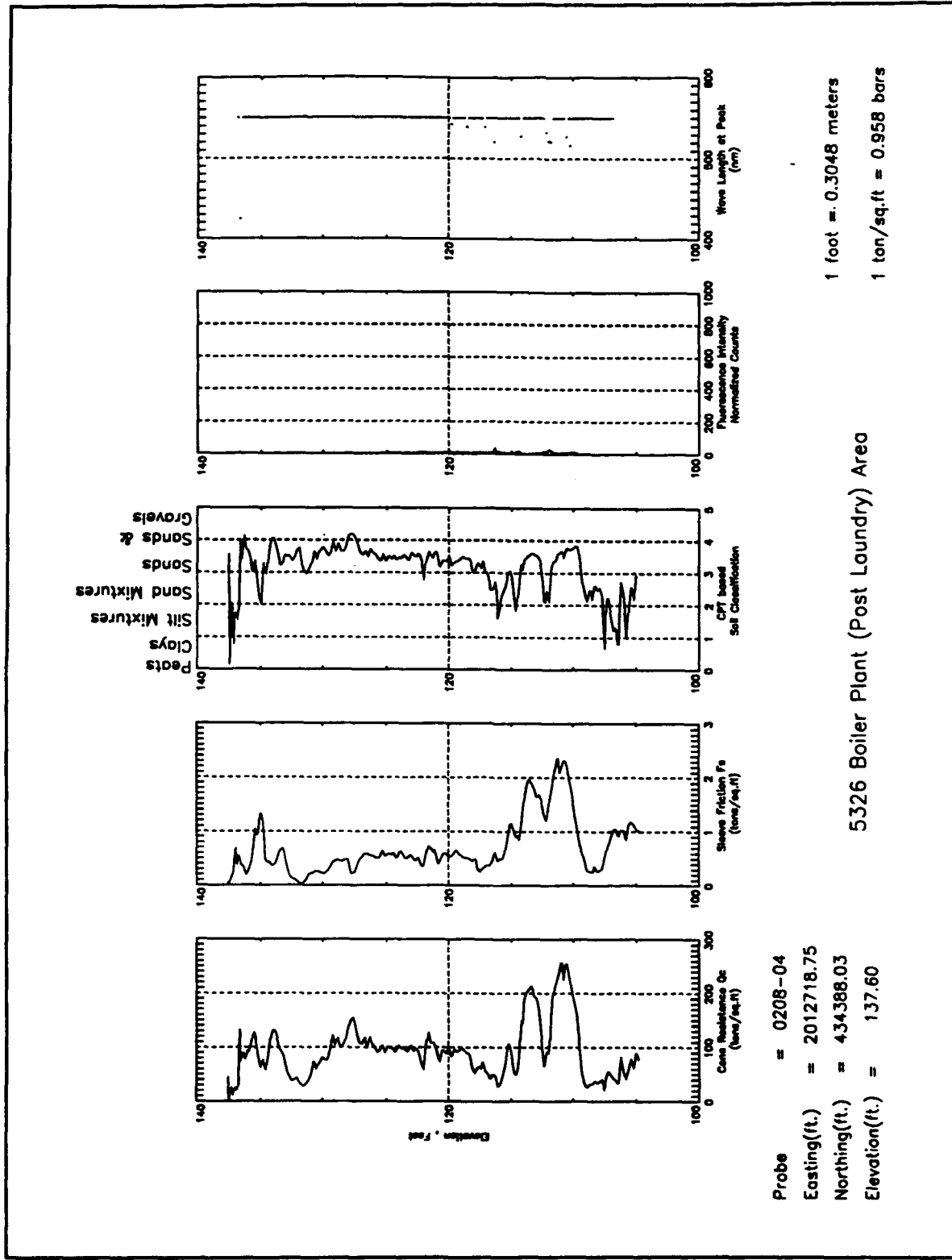

1 foot = 0.3048 meters
 1 ton/sq.ft = 0.958 bars

5326 Boiler Plant (Post Laundry) Area

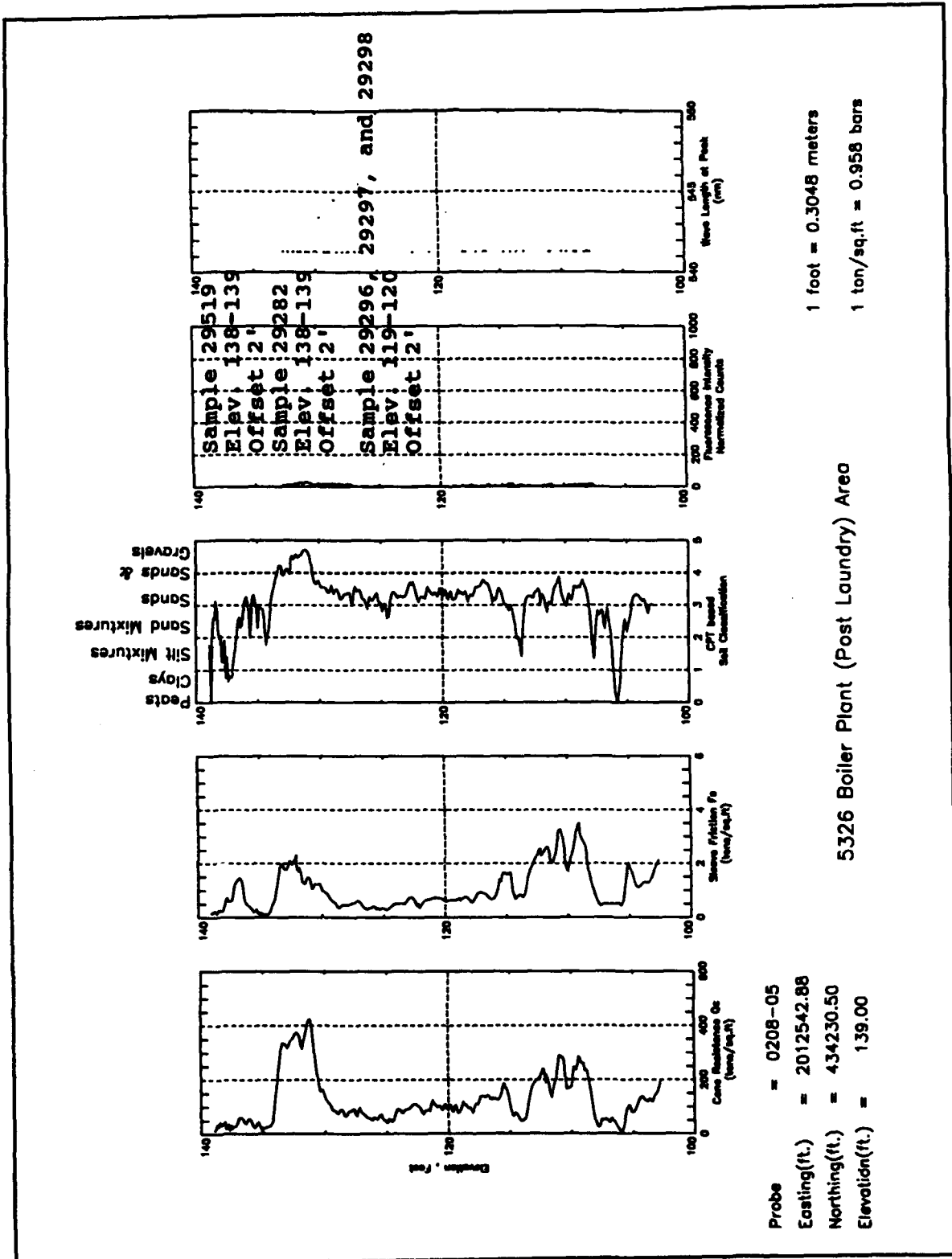

5326 Boiler Plant (Post Laundry) Area

1 foot = 0.3048 meters
 1 ton/sq.ft = 0.958 bars

Appendix G

5426 Boiler Plant

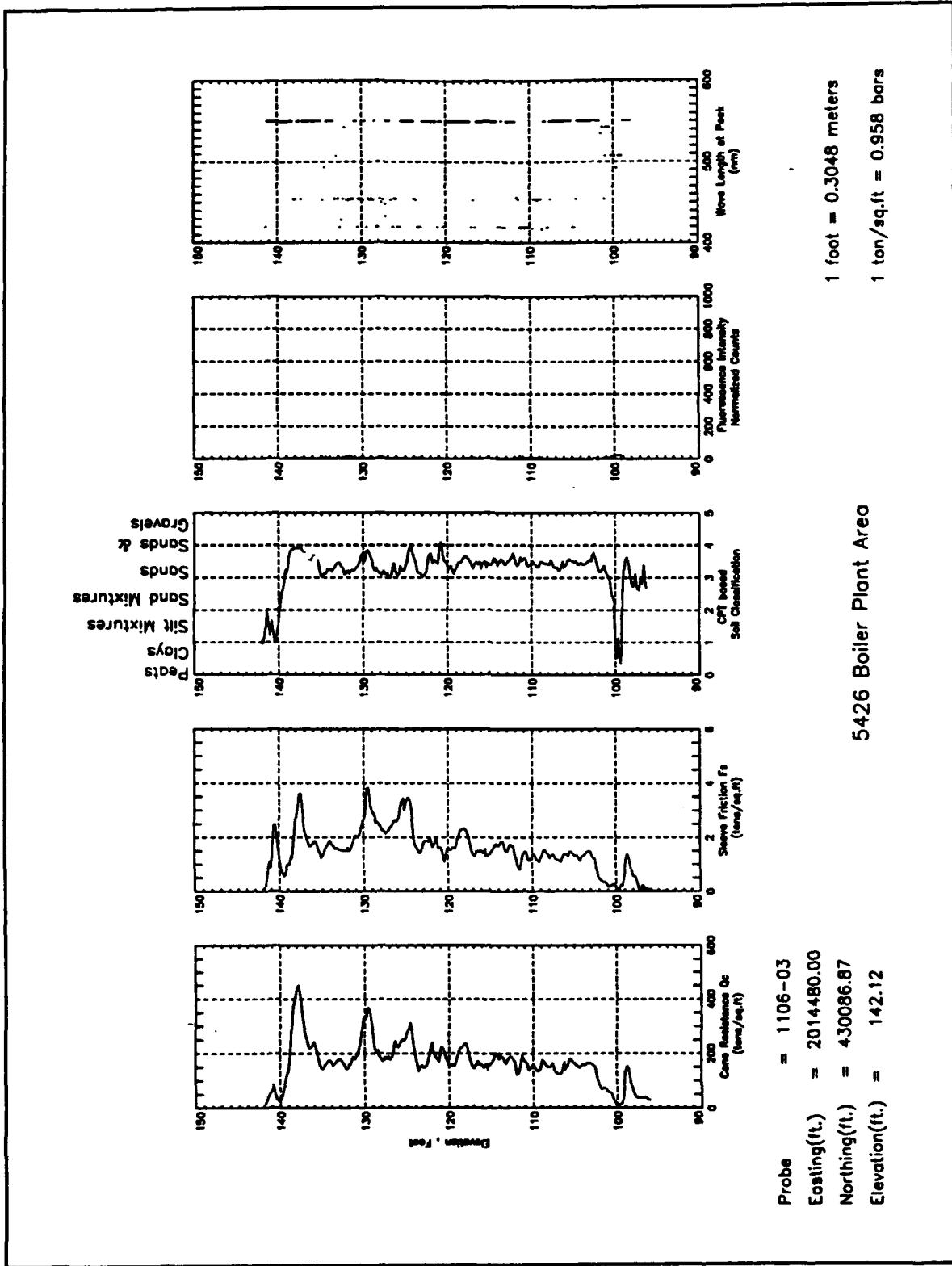

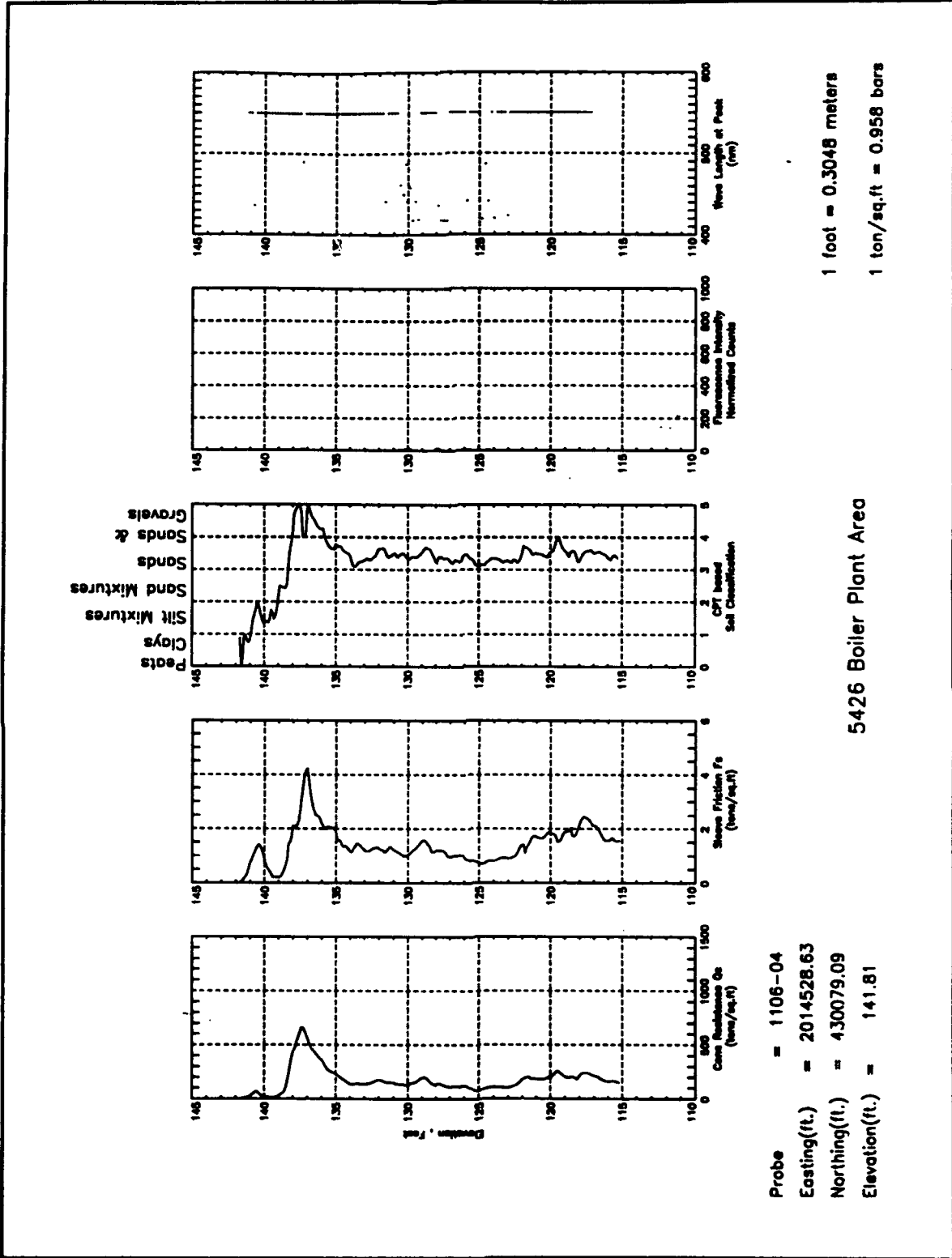

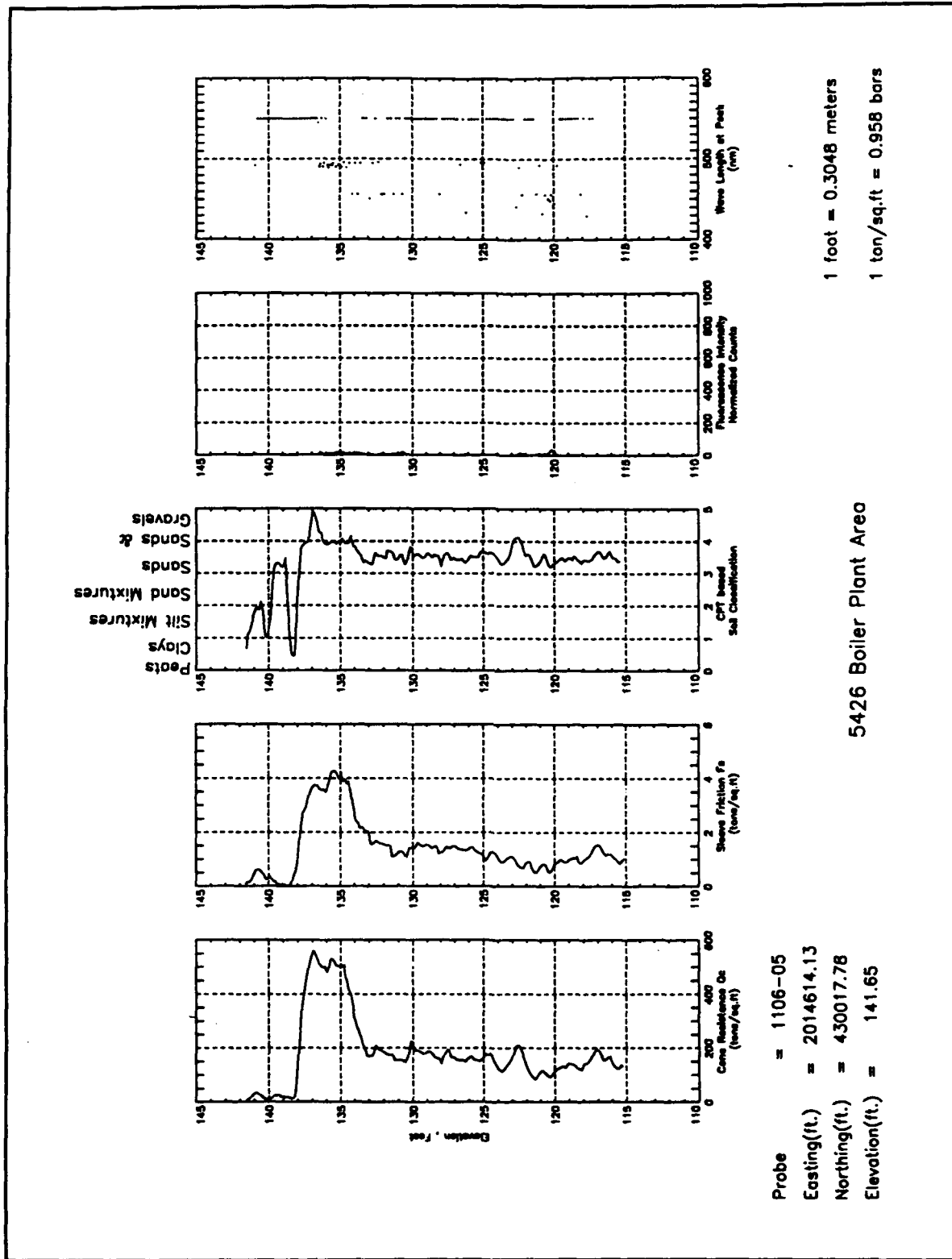

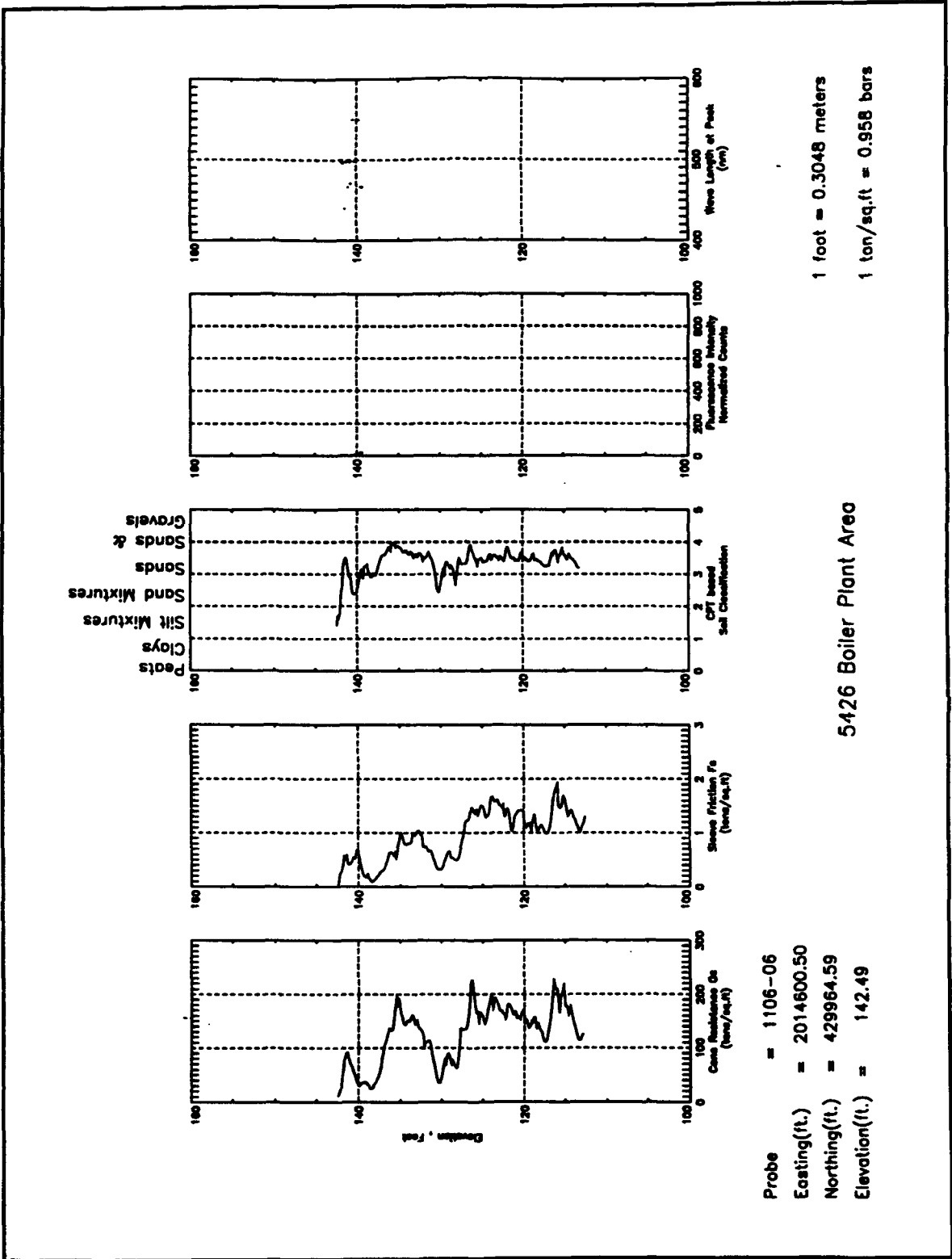

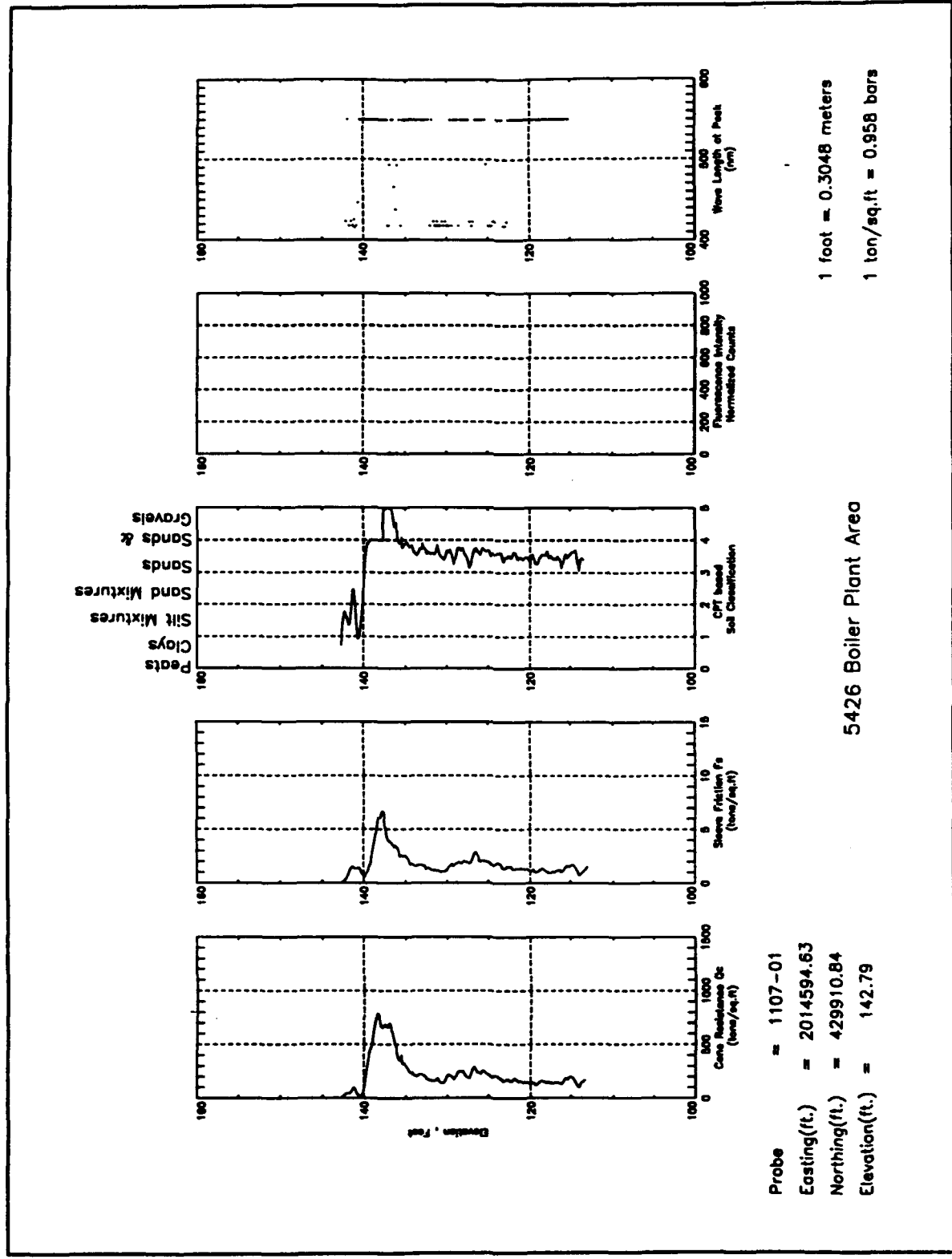

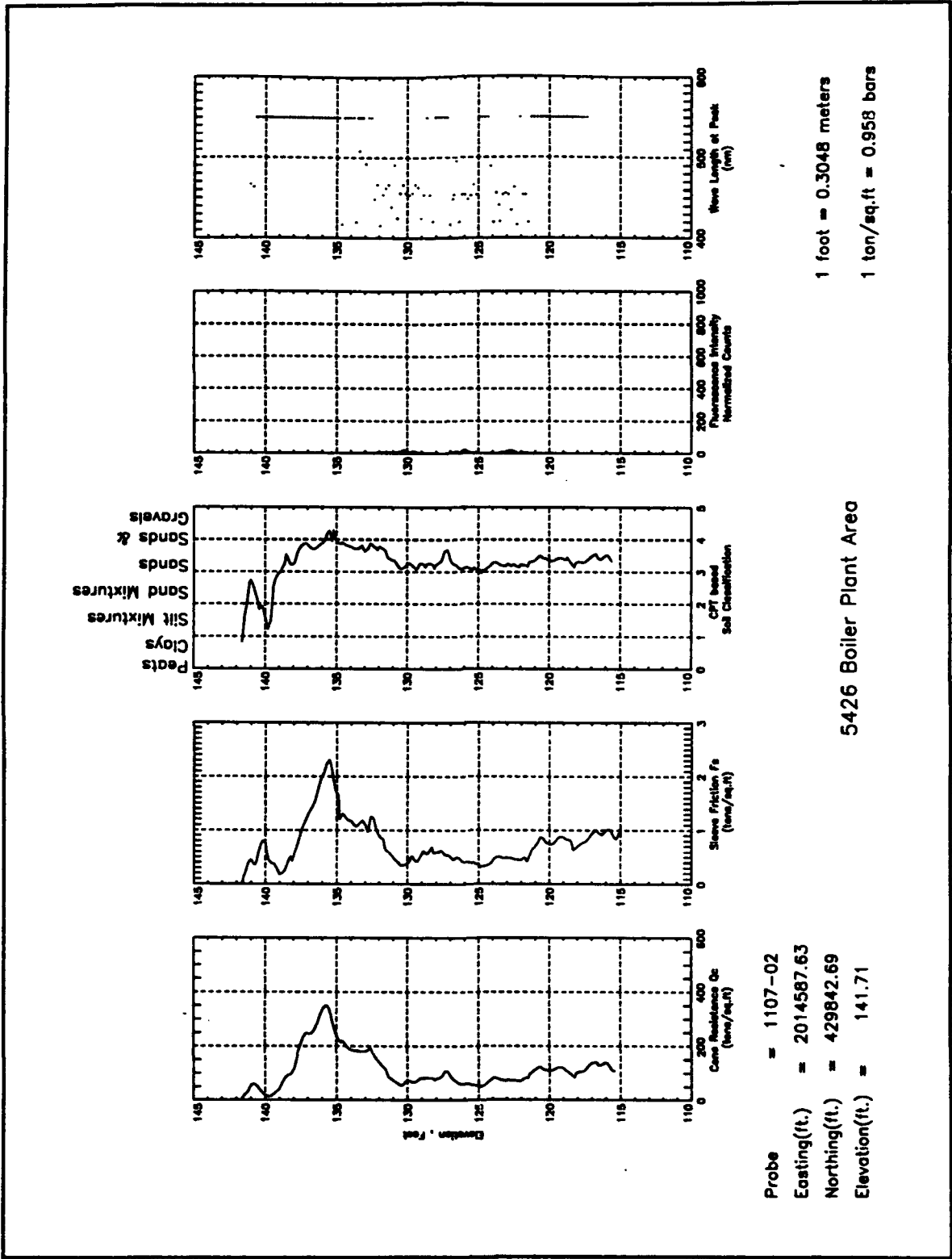

Probe = 1107-02
 Easting(ft.) = 2014567.63
 Northing(ft.) = 429842.69
 Elevation(ft.) = 141.71

1 foot = 0.3048 meters
 1 ton/sq.ft = 0.958 bars

5426 Boiler Plant Area

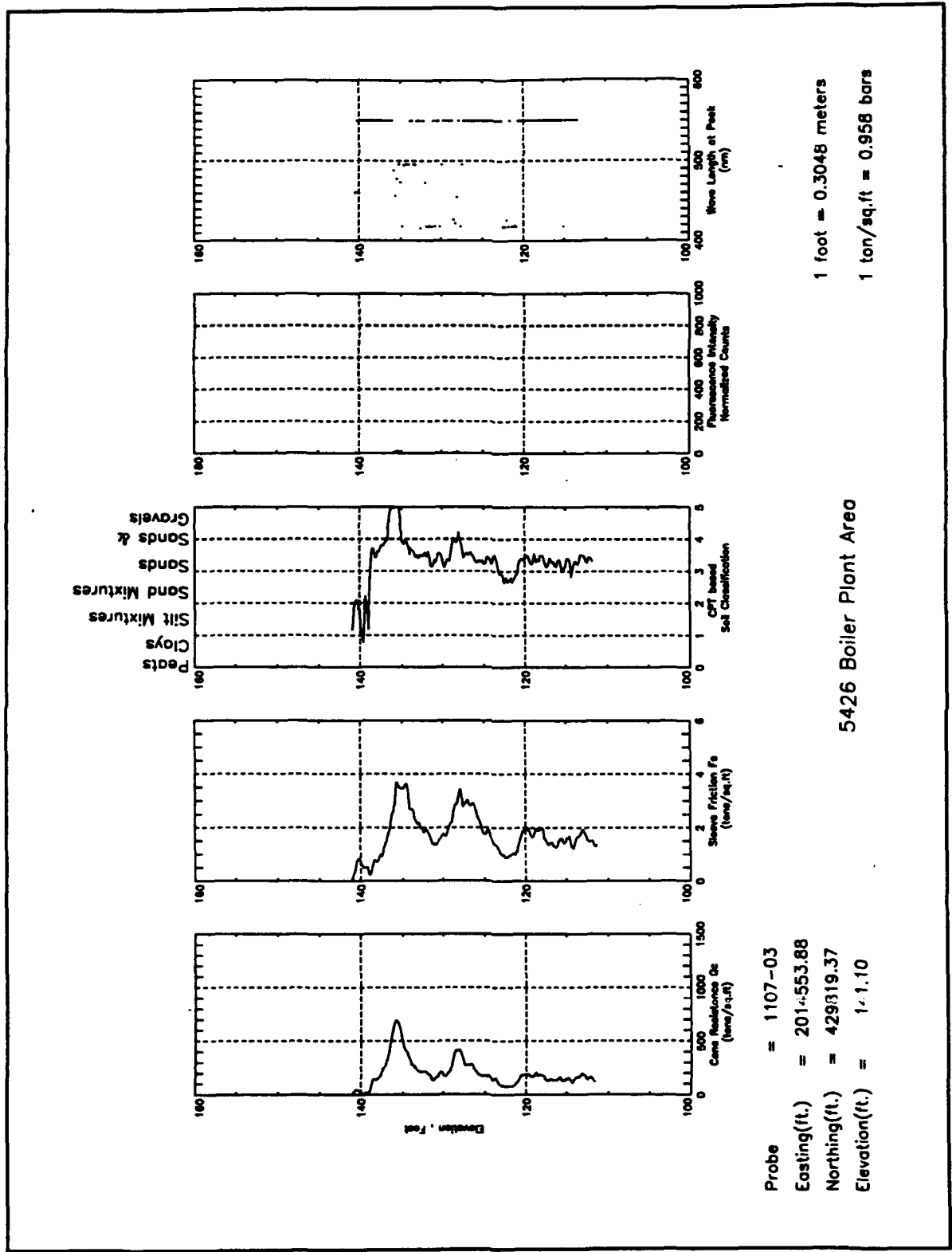

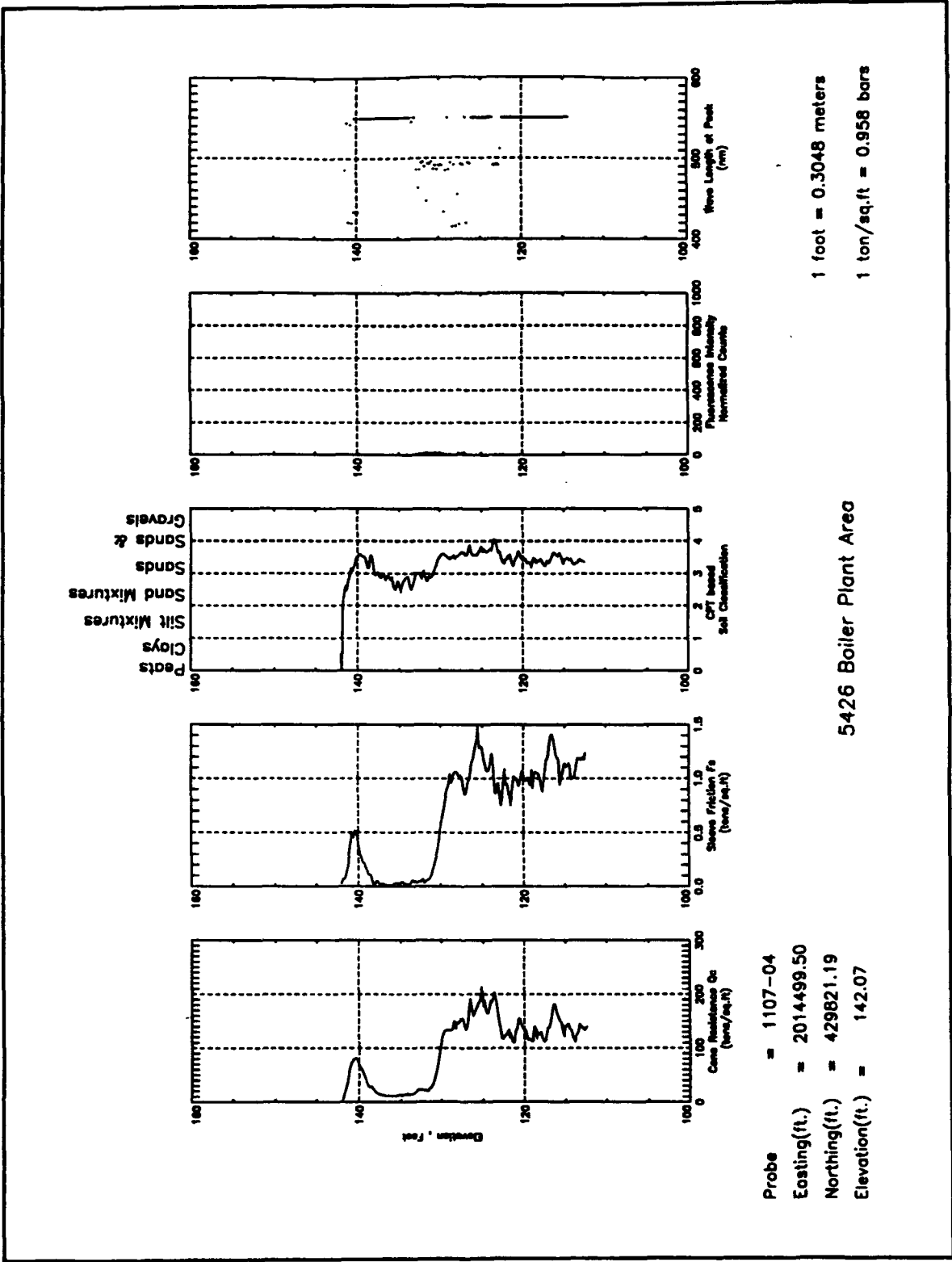

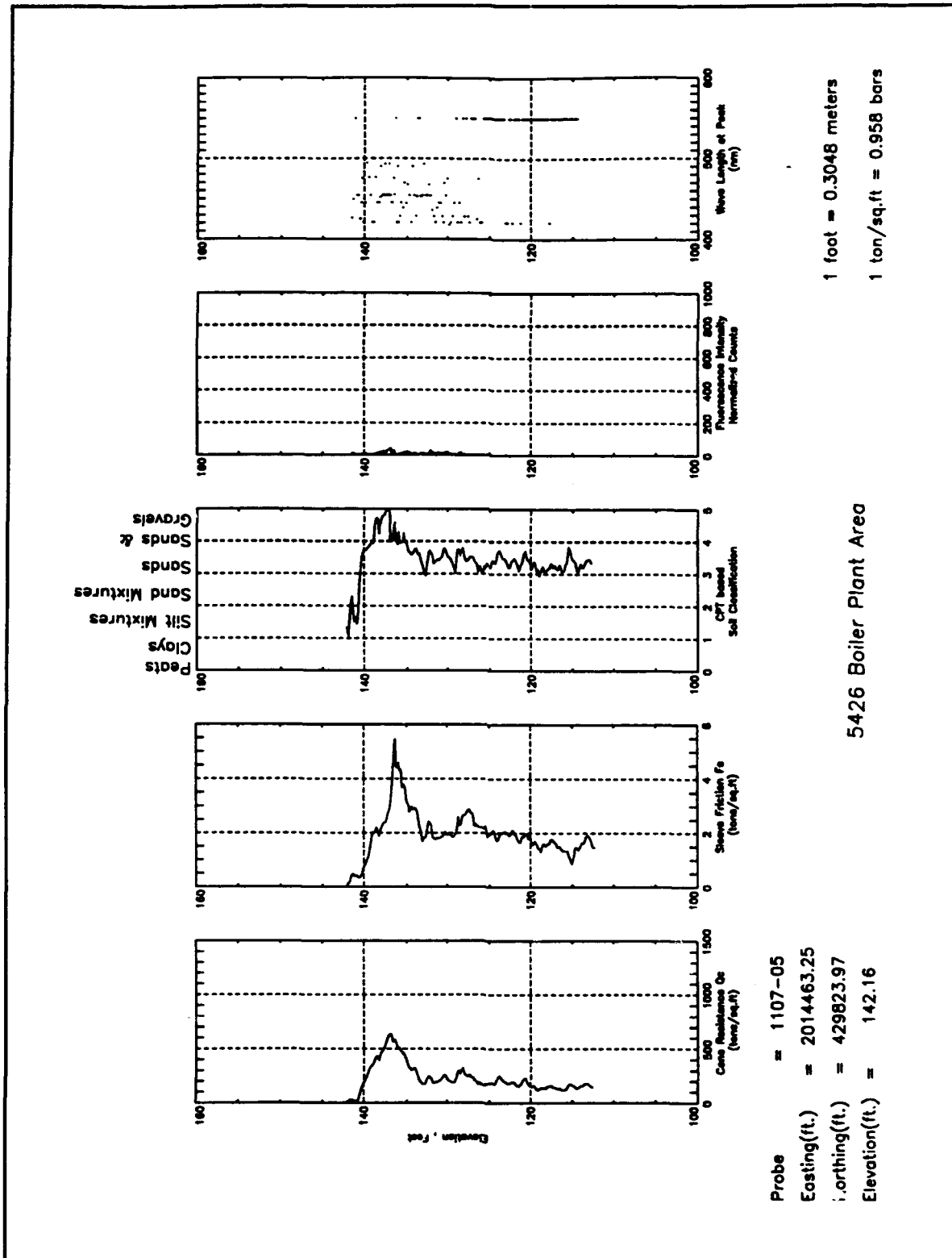

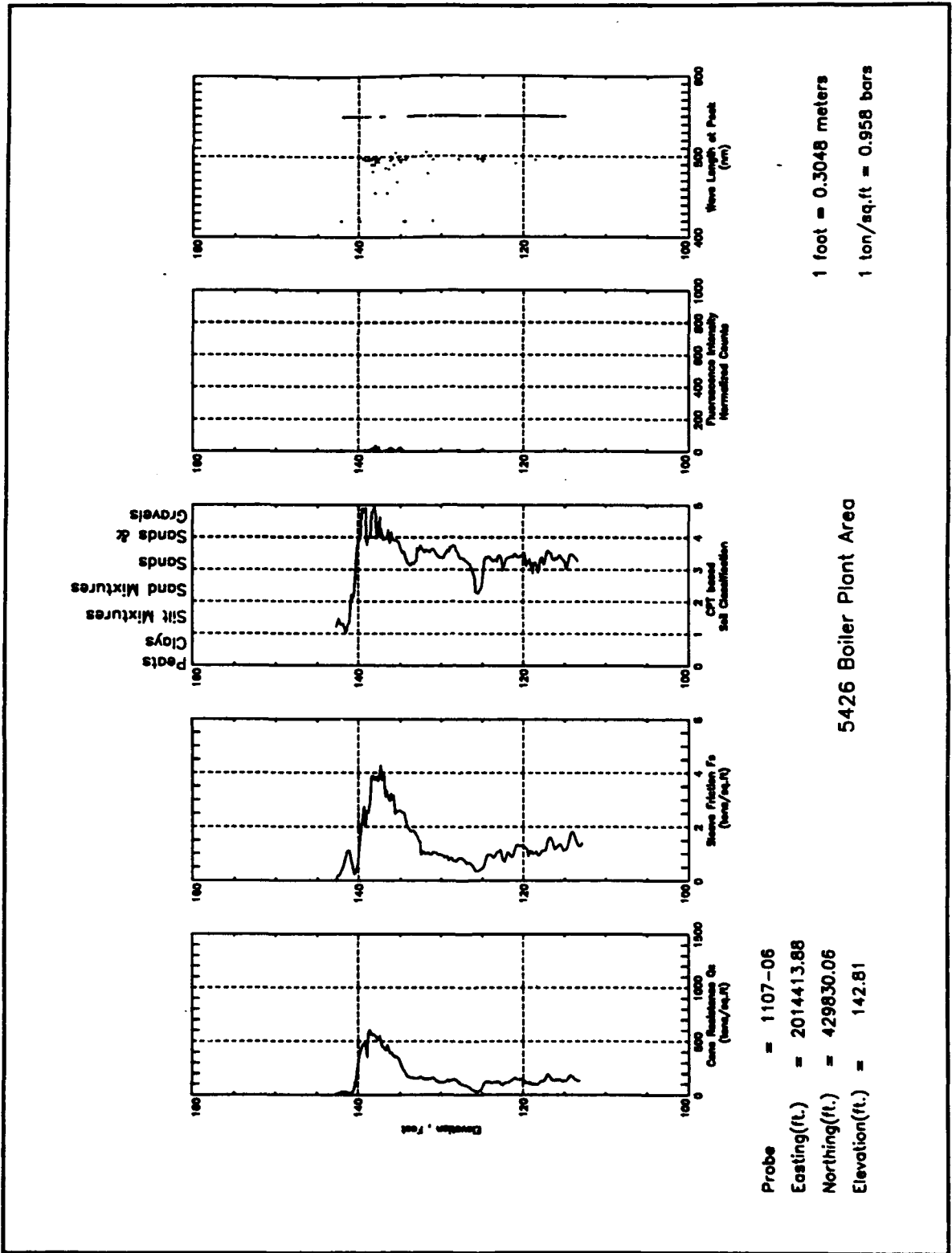

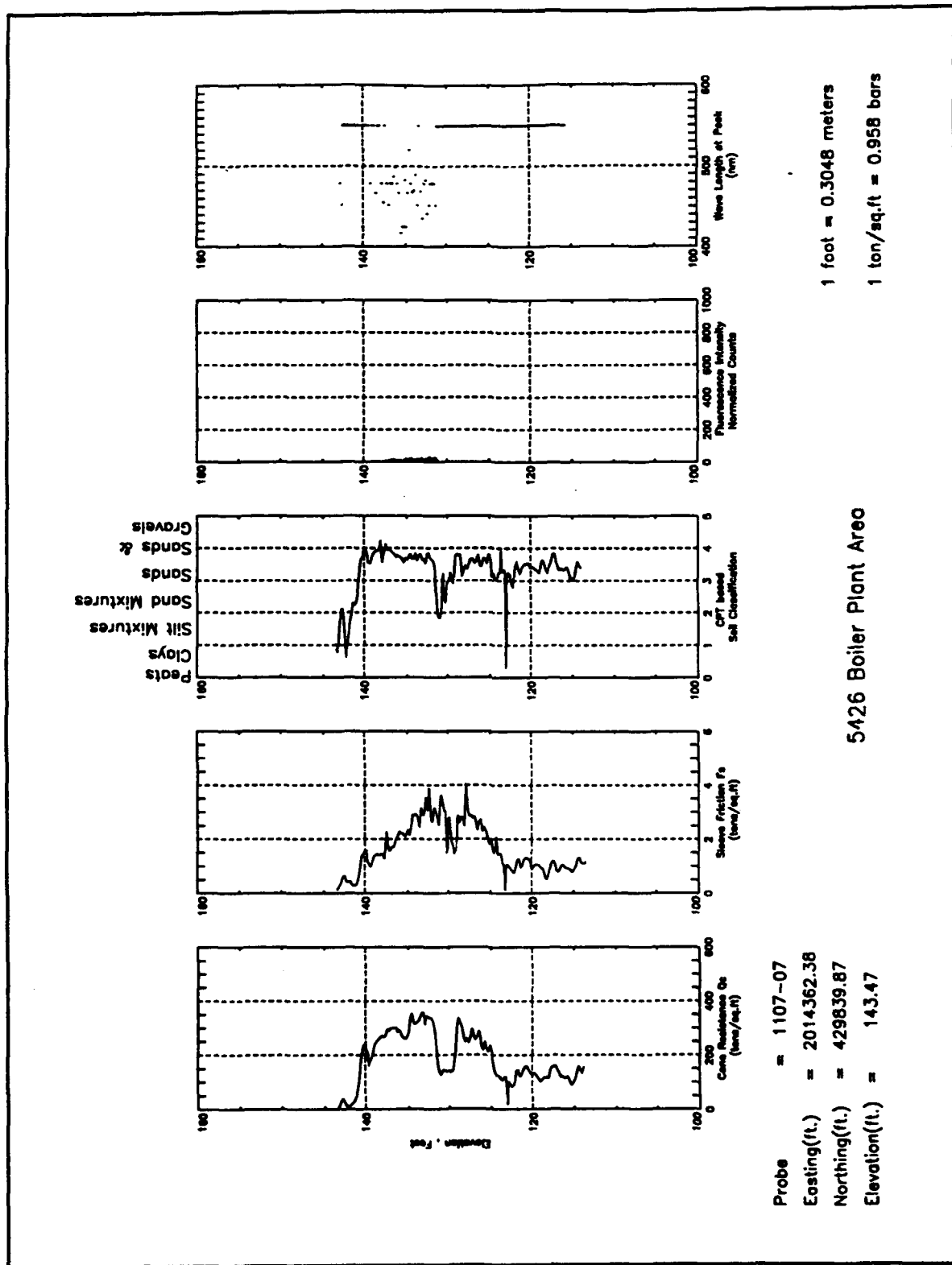

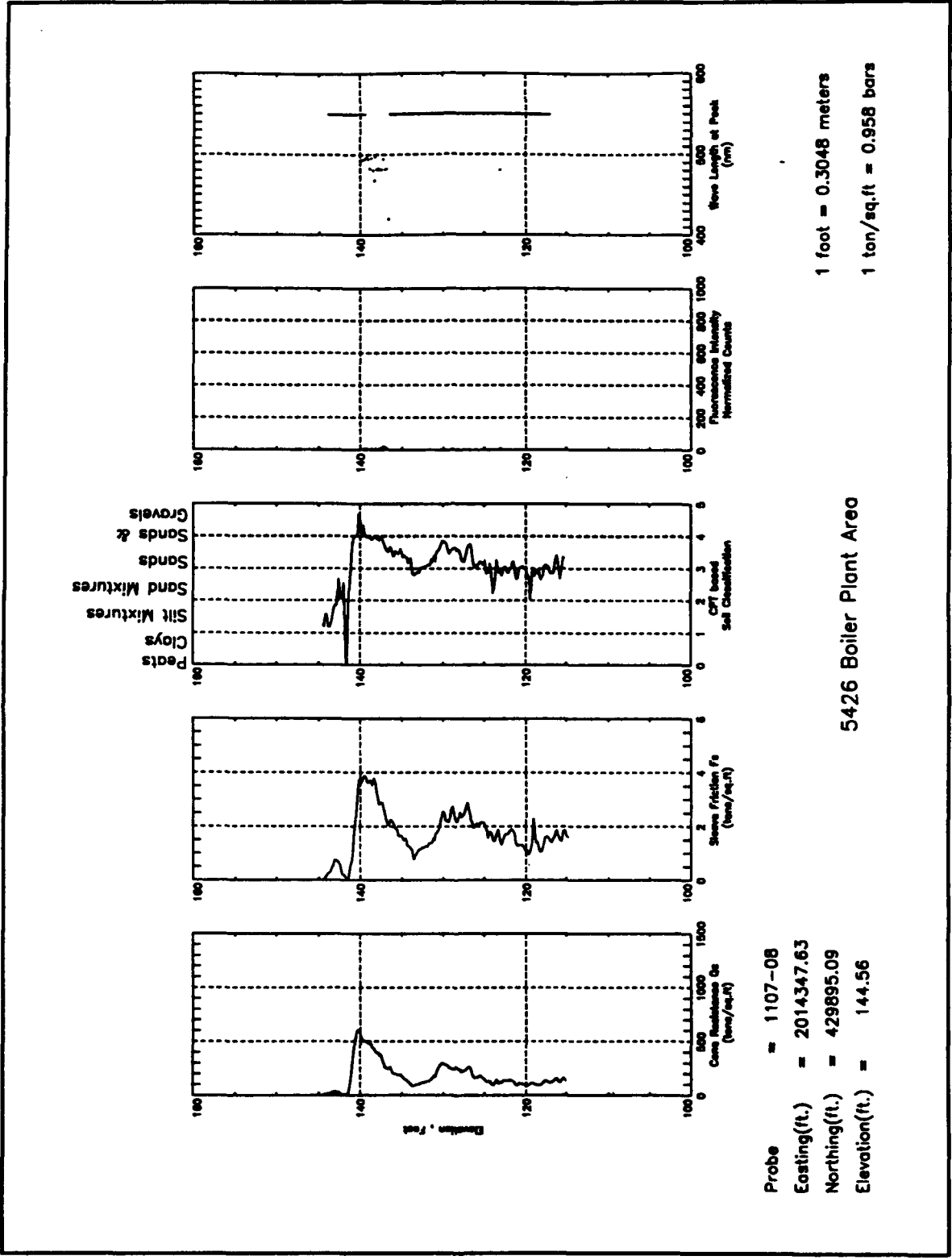

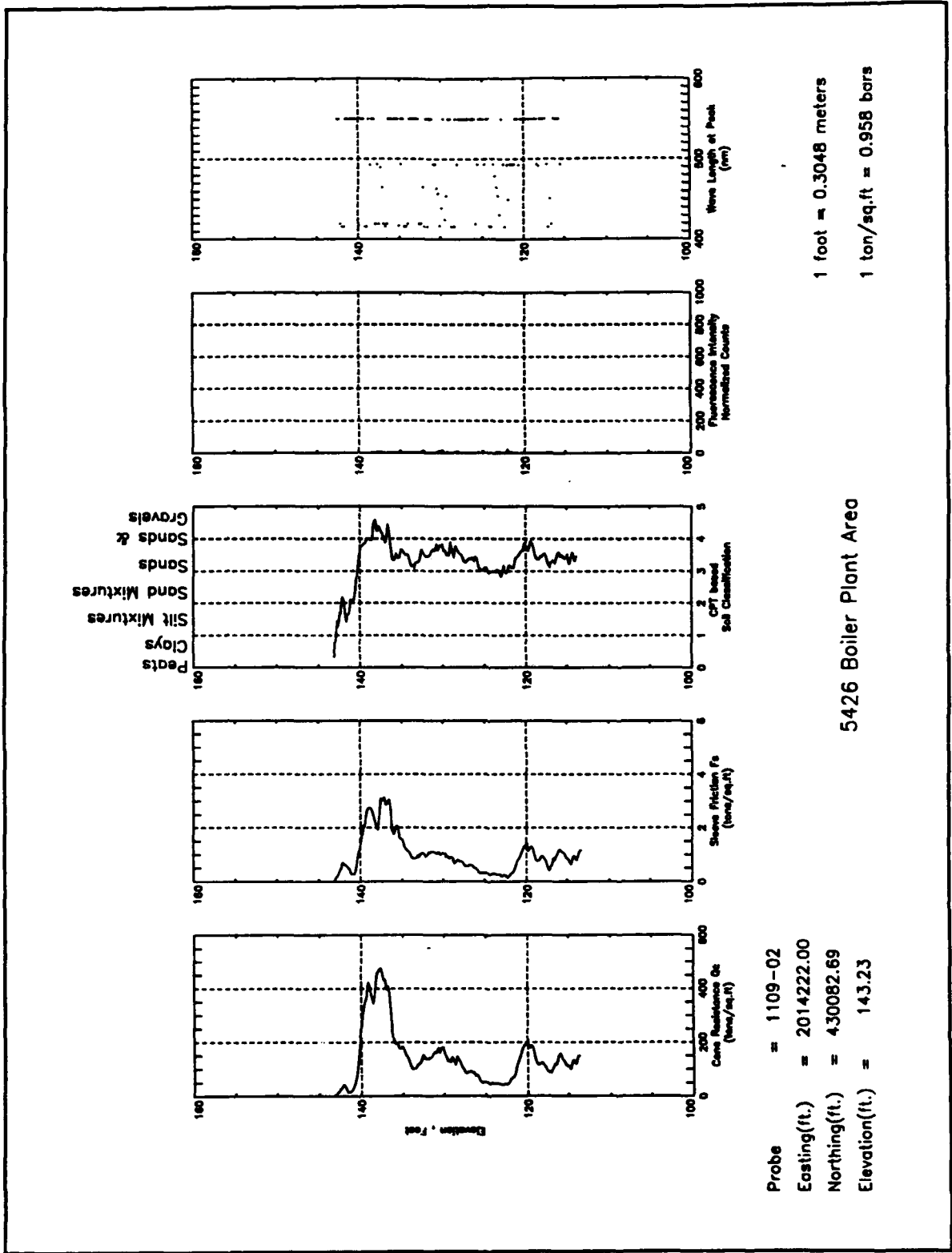

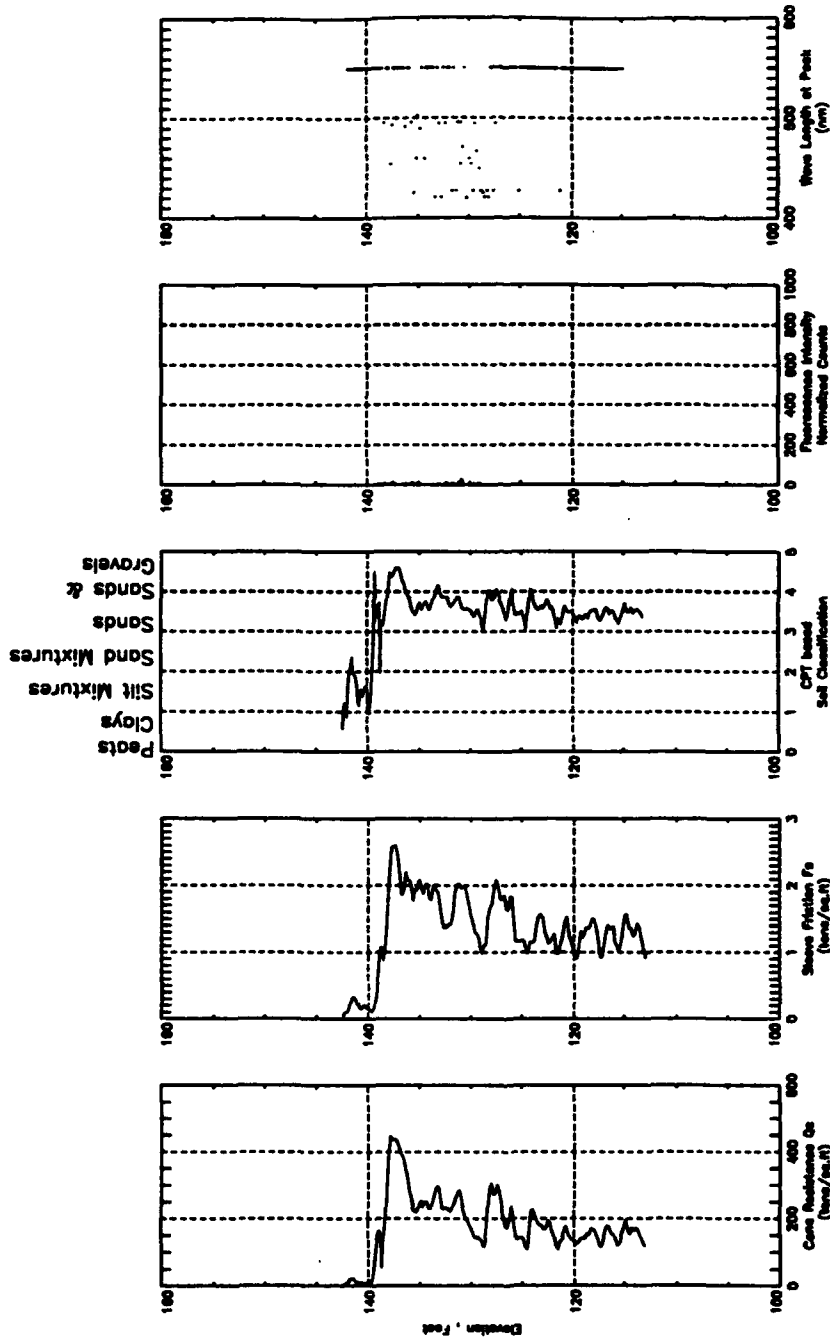

Probe = 1109-03
 Easting(ft.) = 2014223.38
 Northing(ft.) = 430138.81
 Elevation(ft.) = 142.51

1 foot = 0.3048 meters
 1 ton/sq.ft = 0.958 bars

5426 Boiler Plant Area

Appendix H

5700 Area Motor Pool

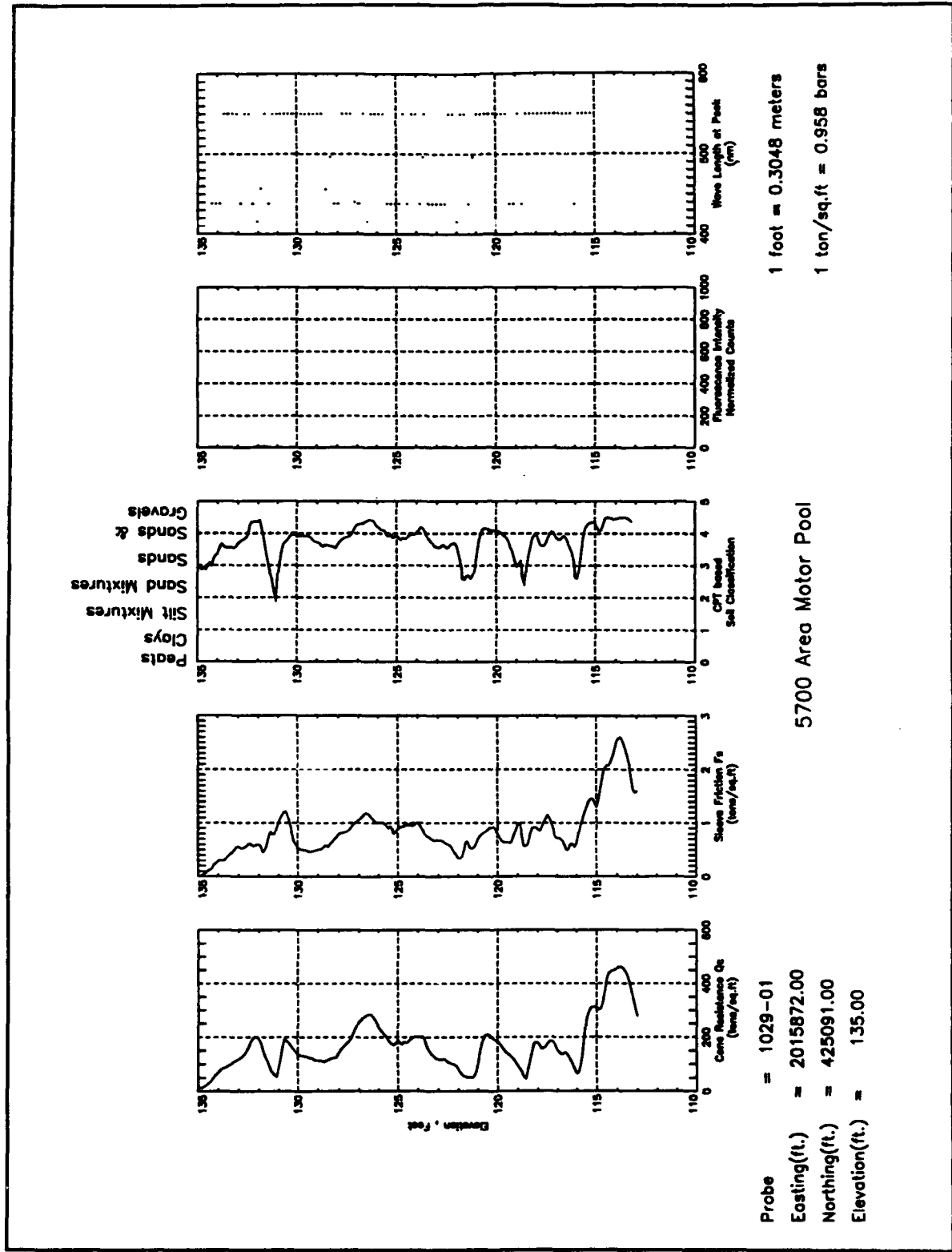

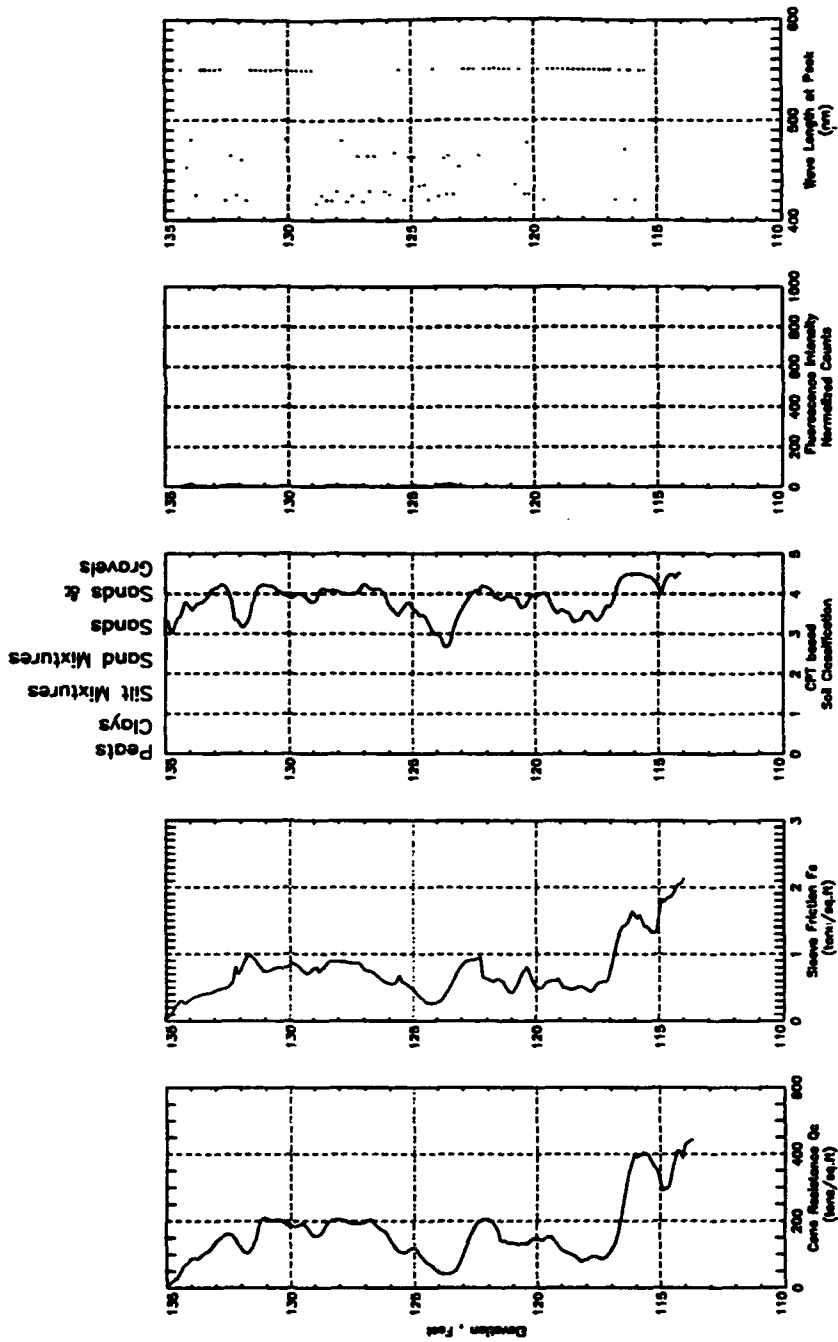

1 foot = 0.3048 meters
 1 ton/sq.ft = 0.958 bars

5700 Area Motor Pool

Probe = 1029-02
 Easting(ft.) = 2015912.00
 Northing(ft.) = 425131.00
 Elevation(ft.) = 135.00

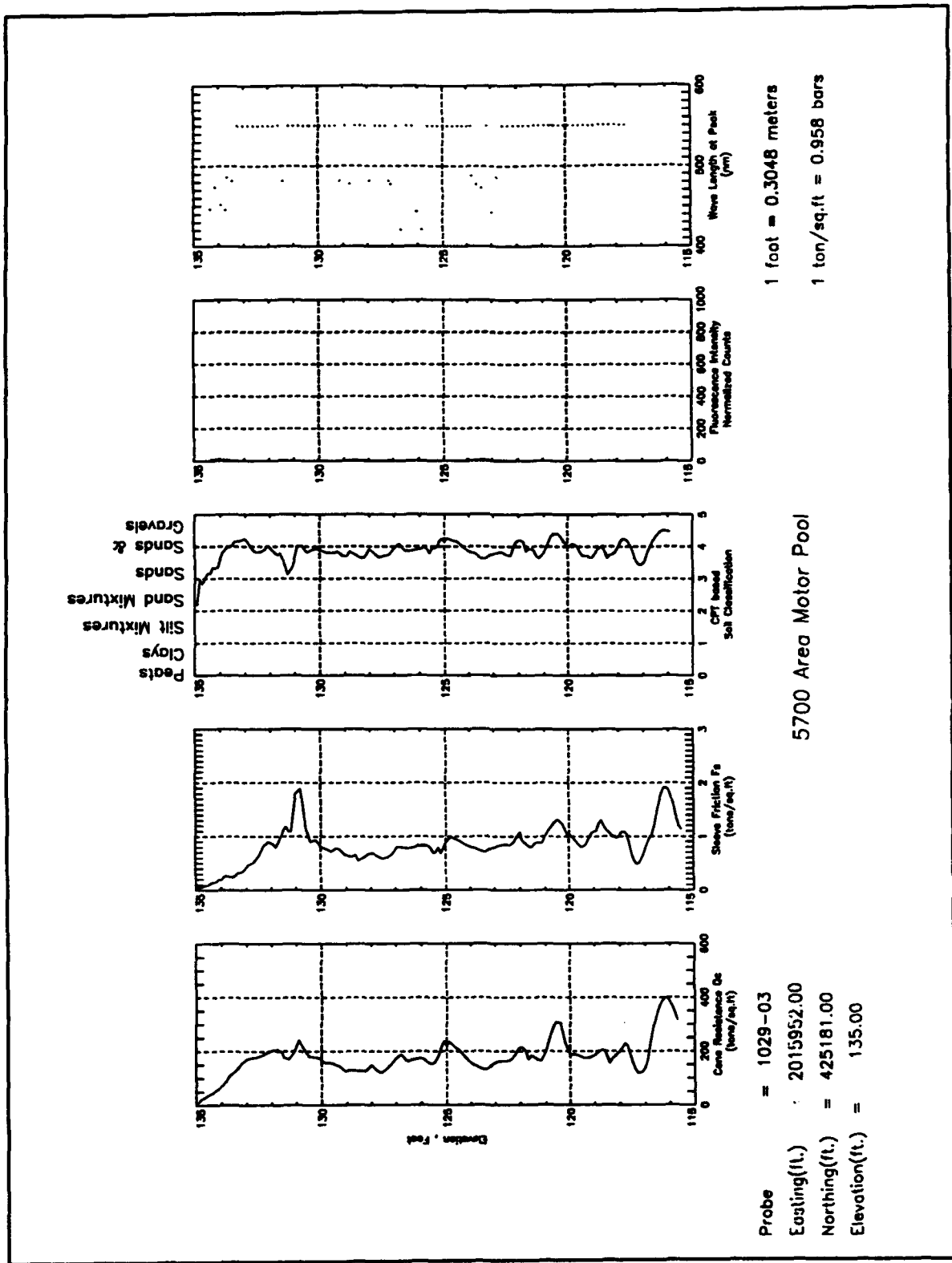

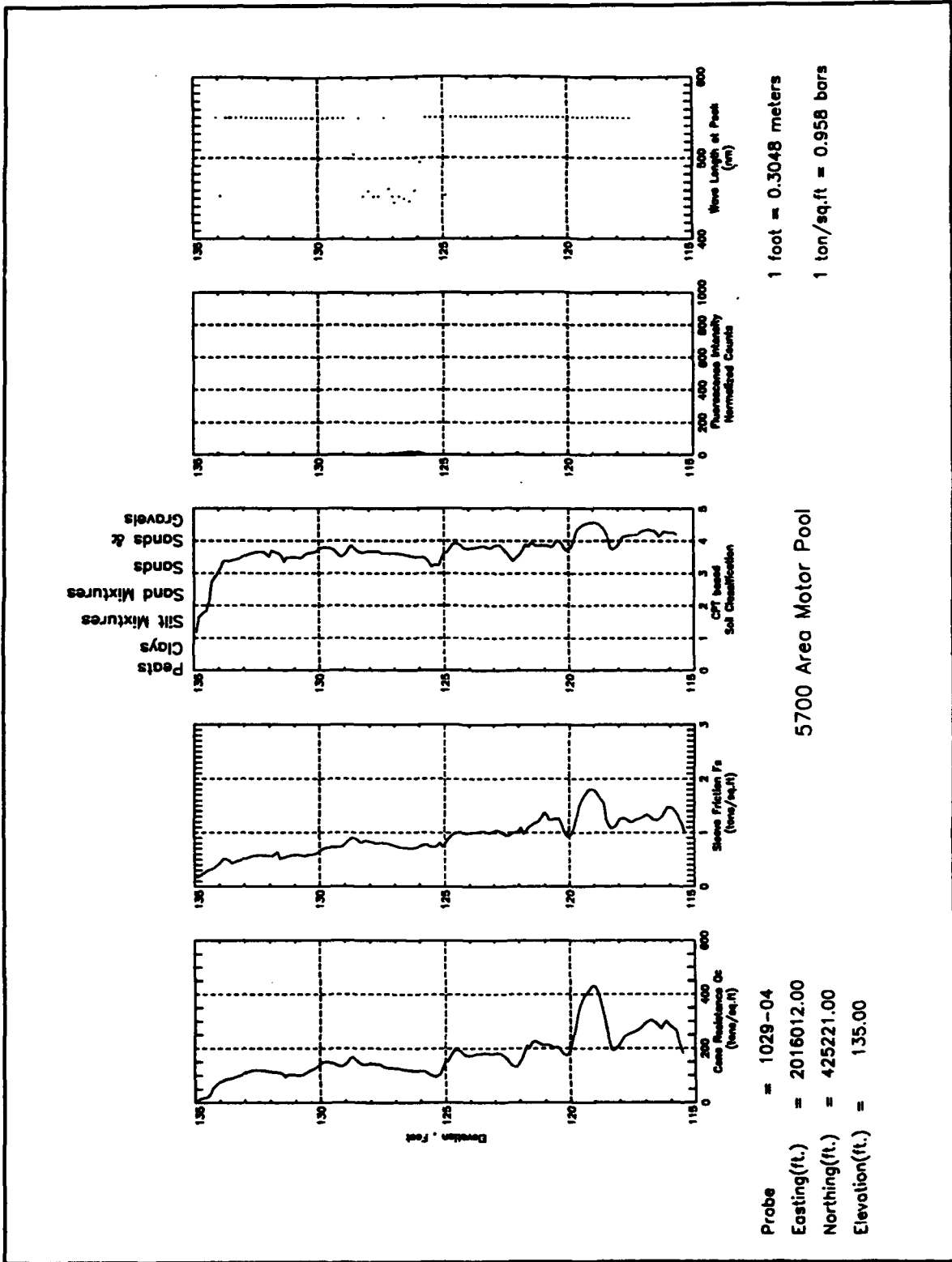

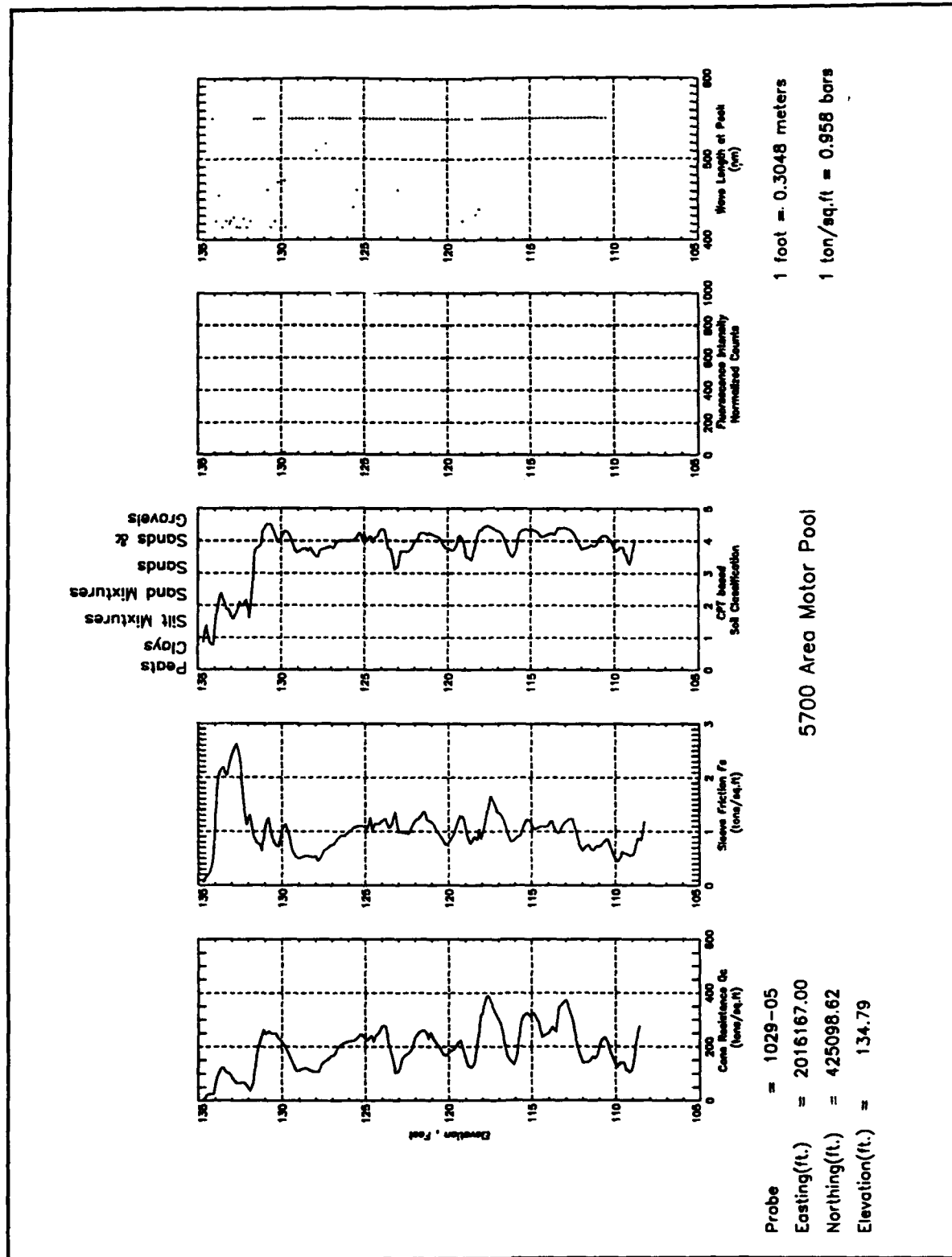

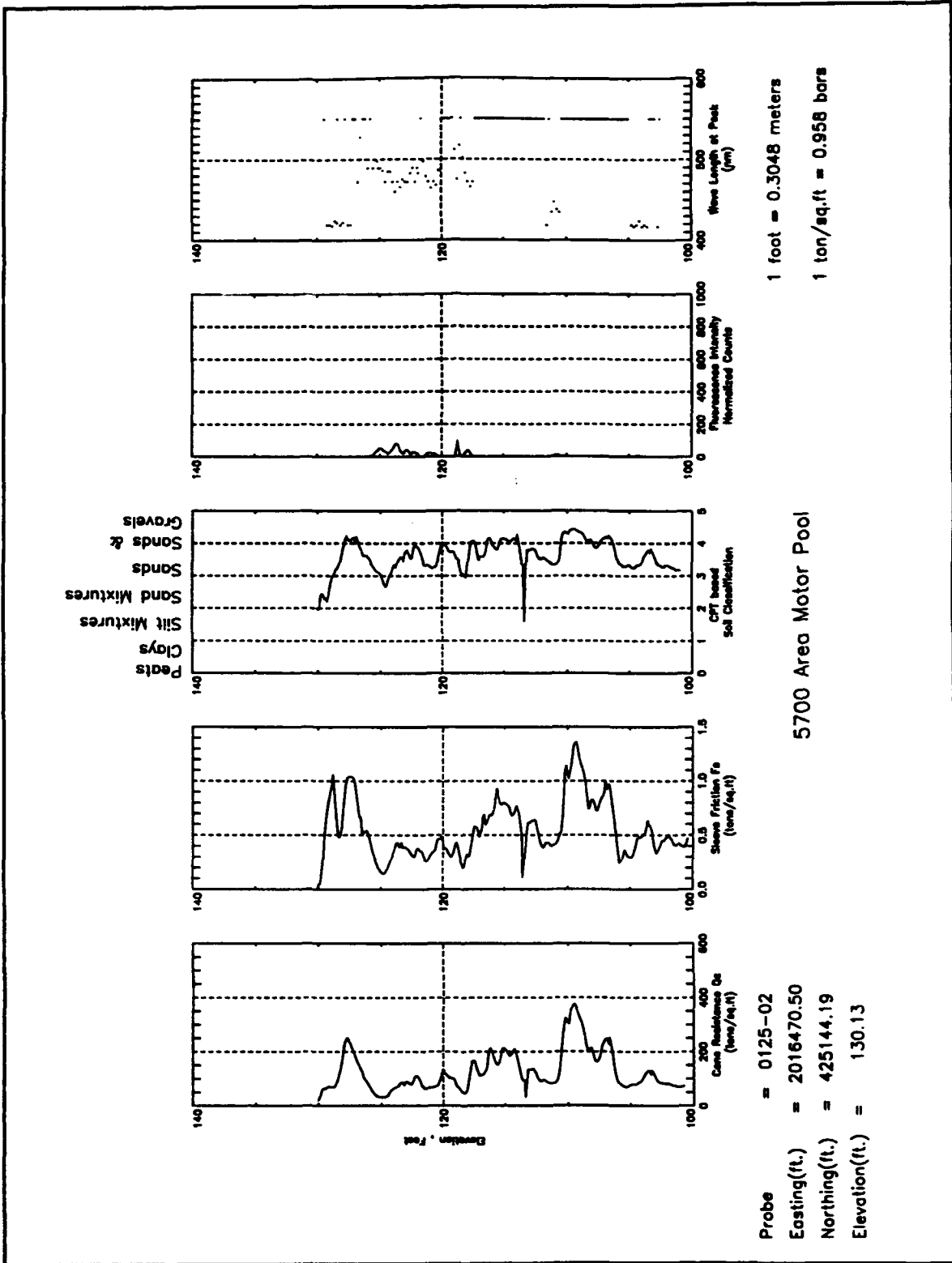

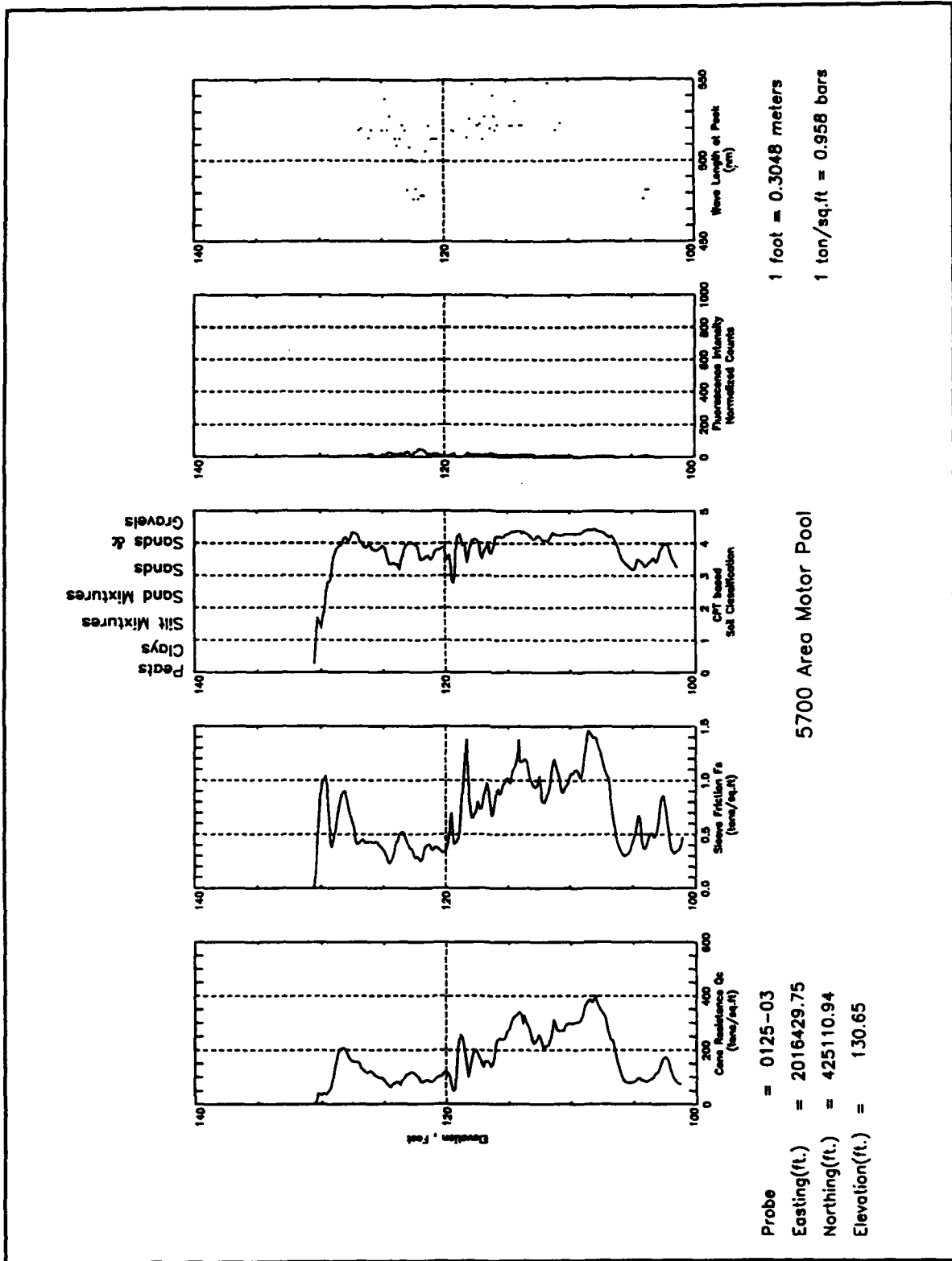

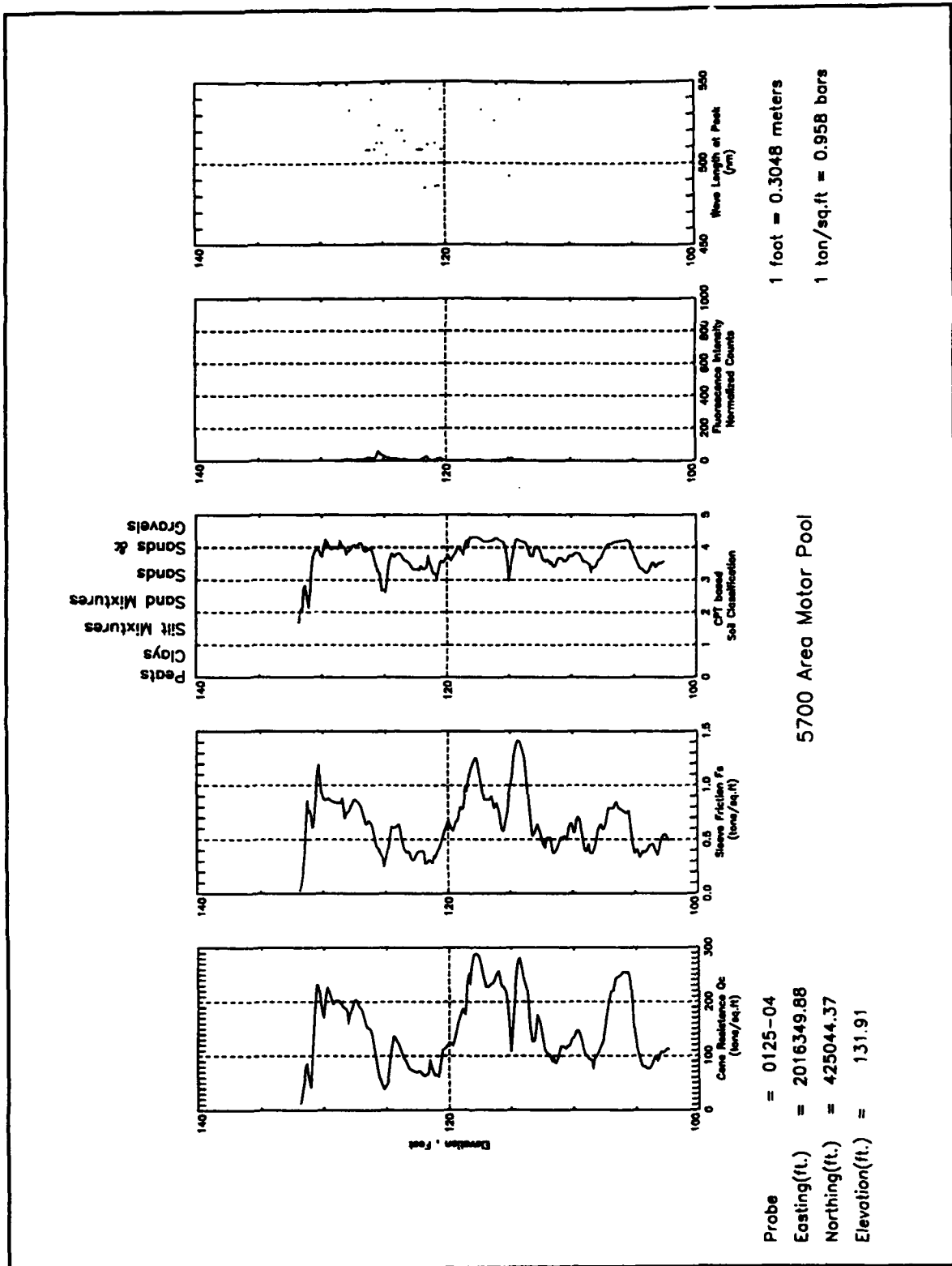

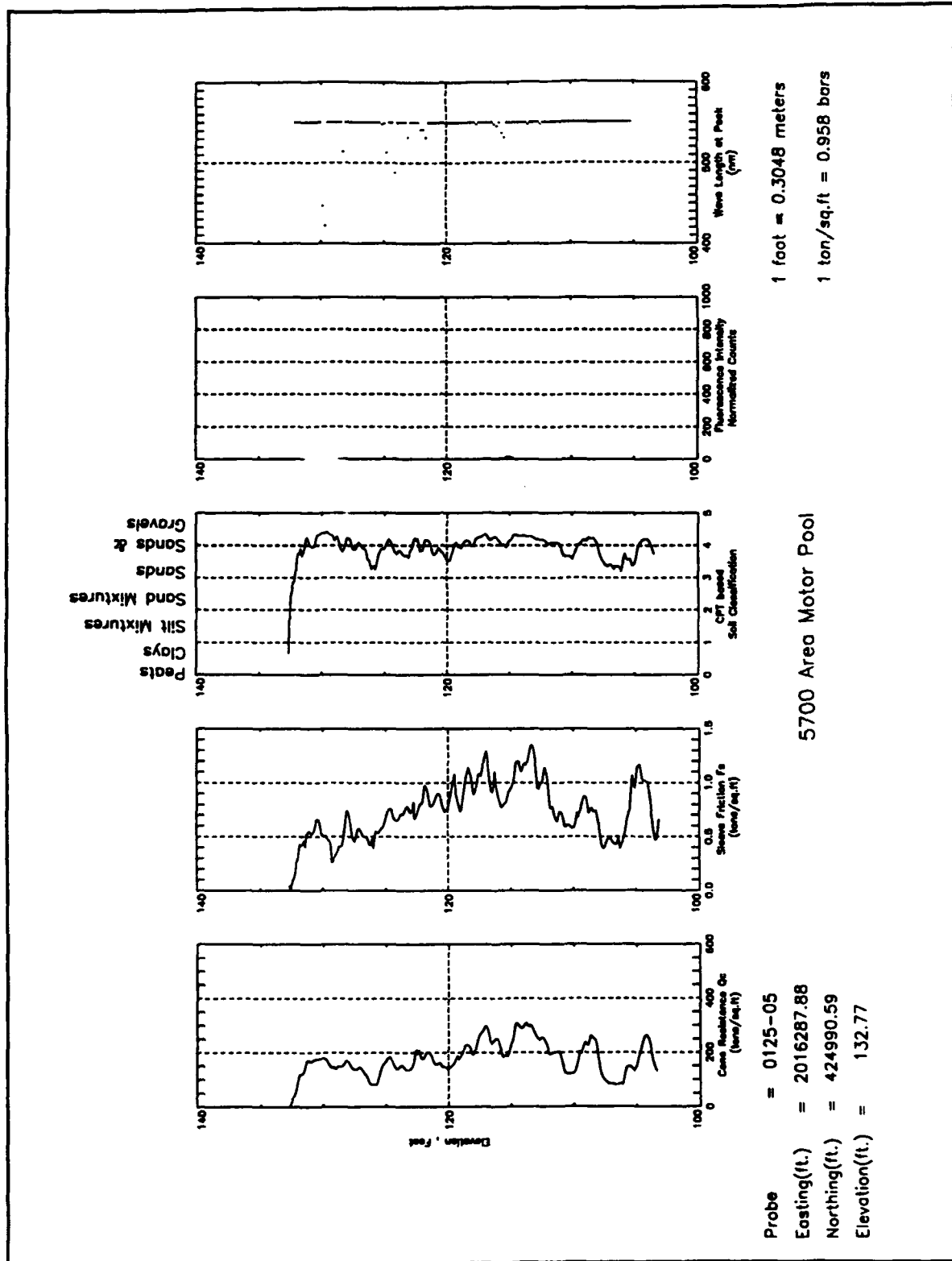

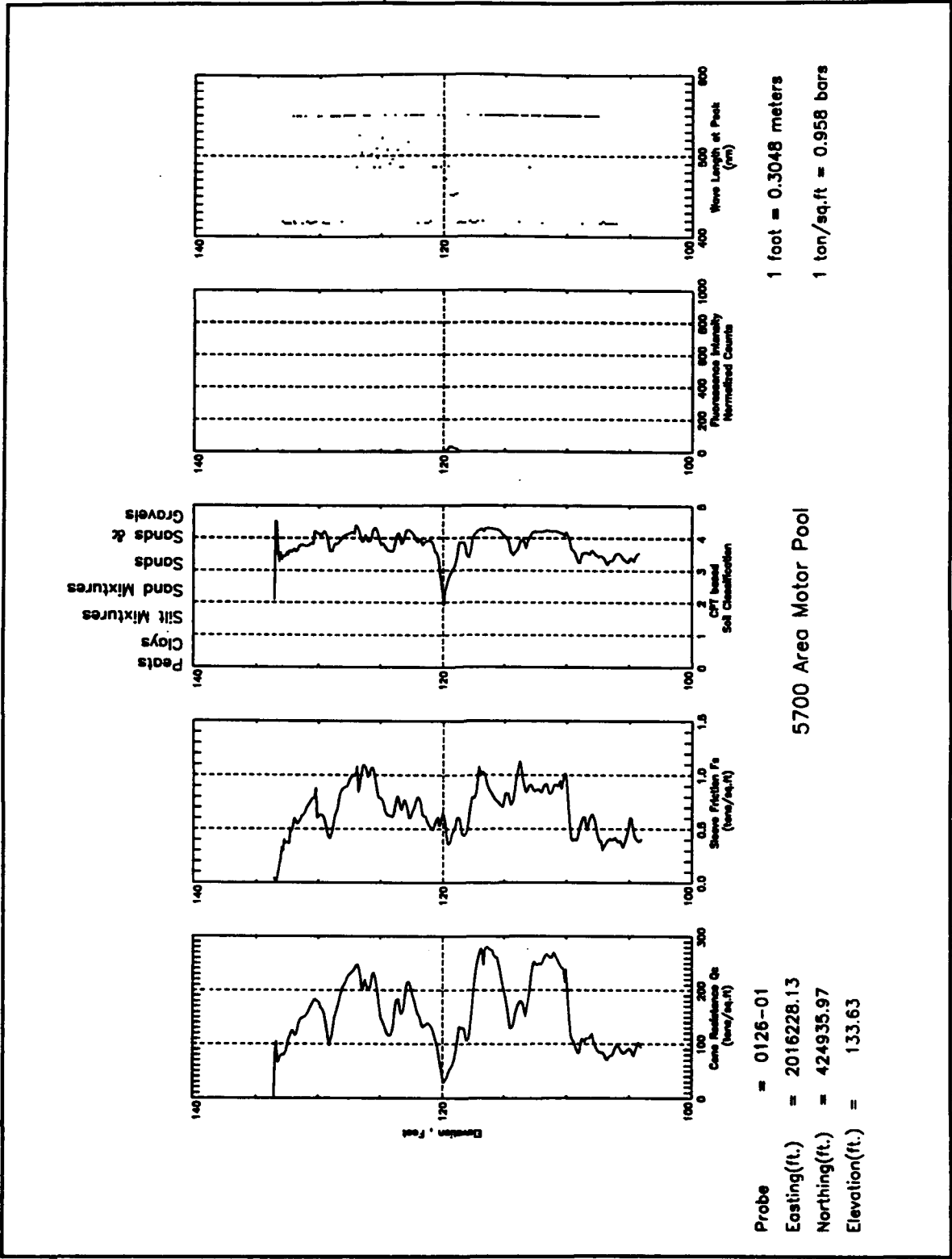

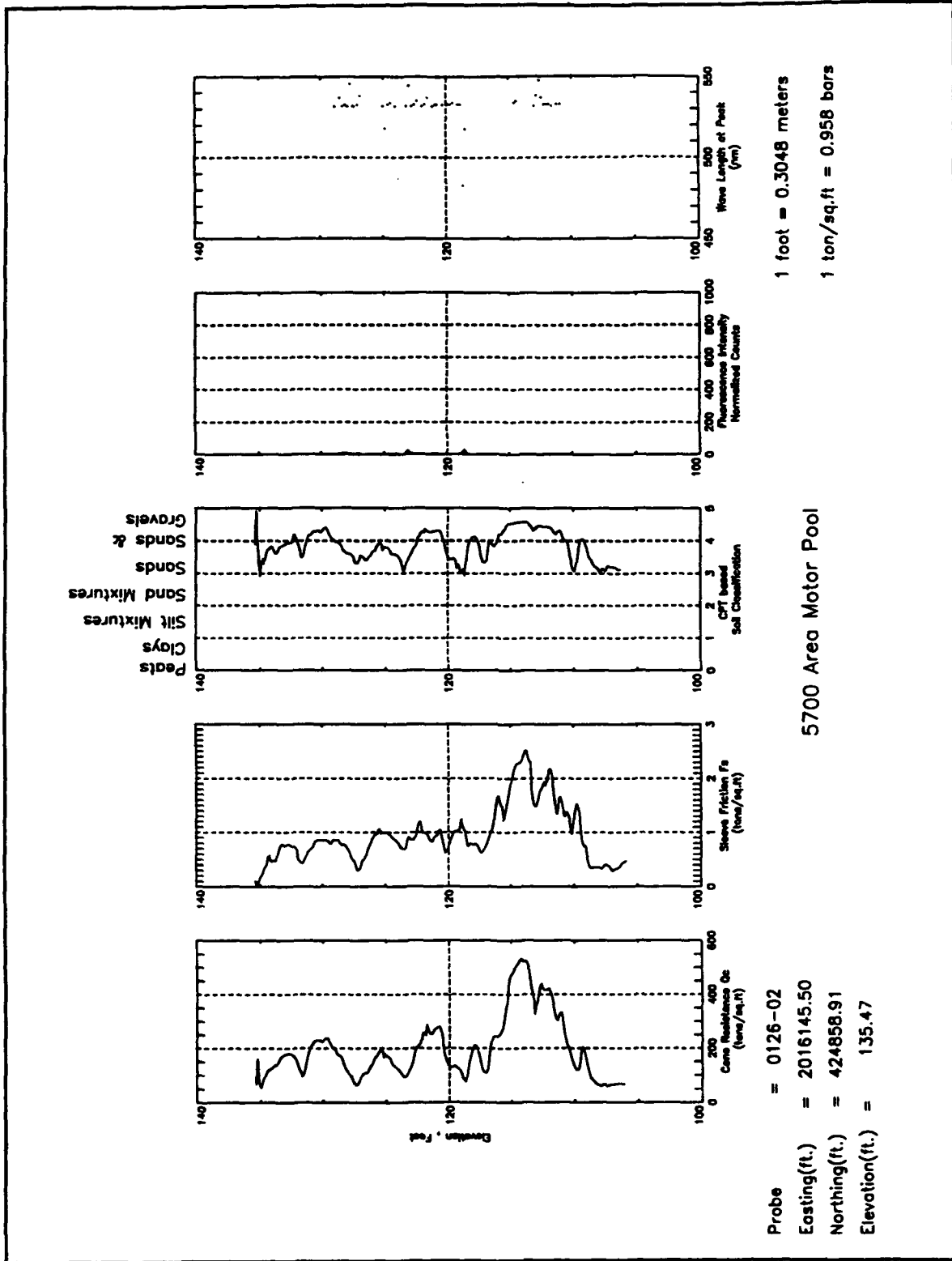

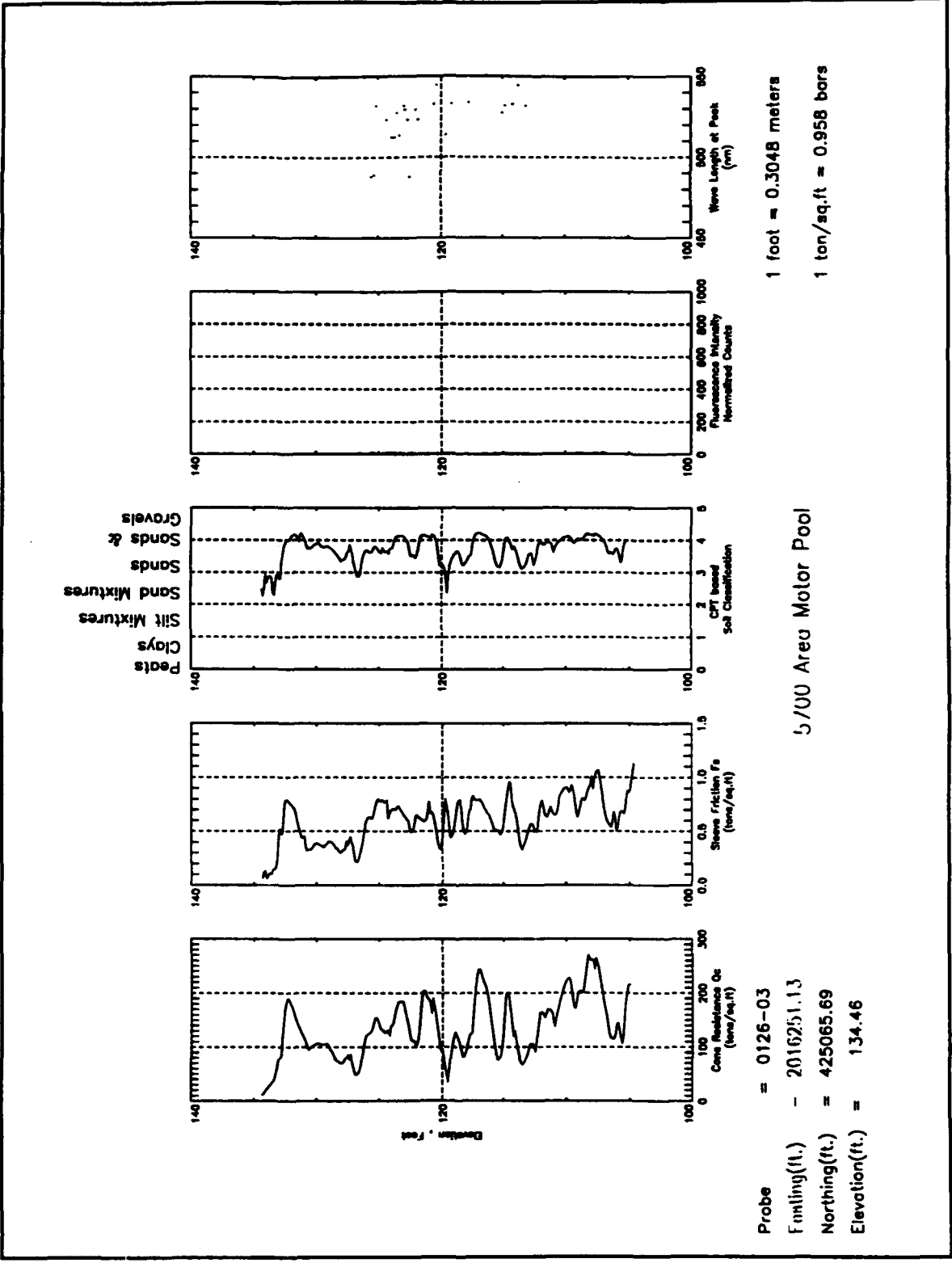

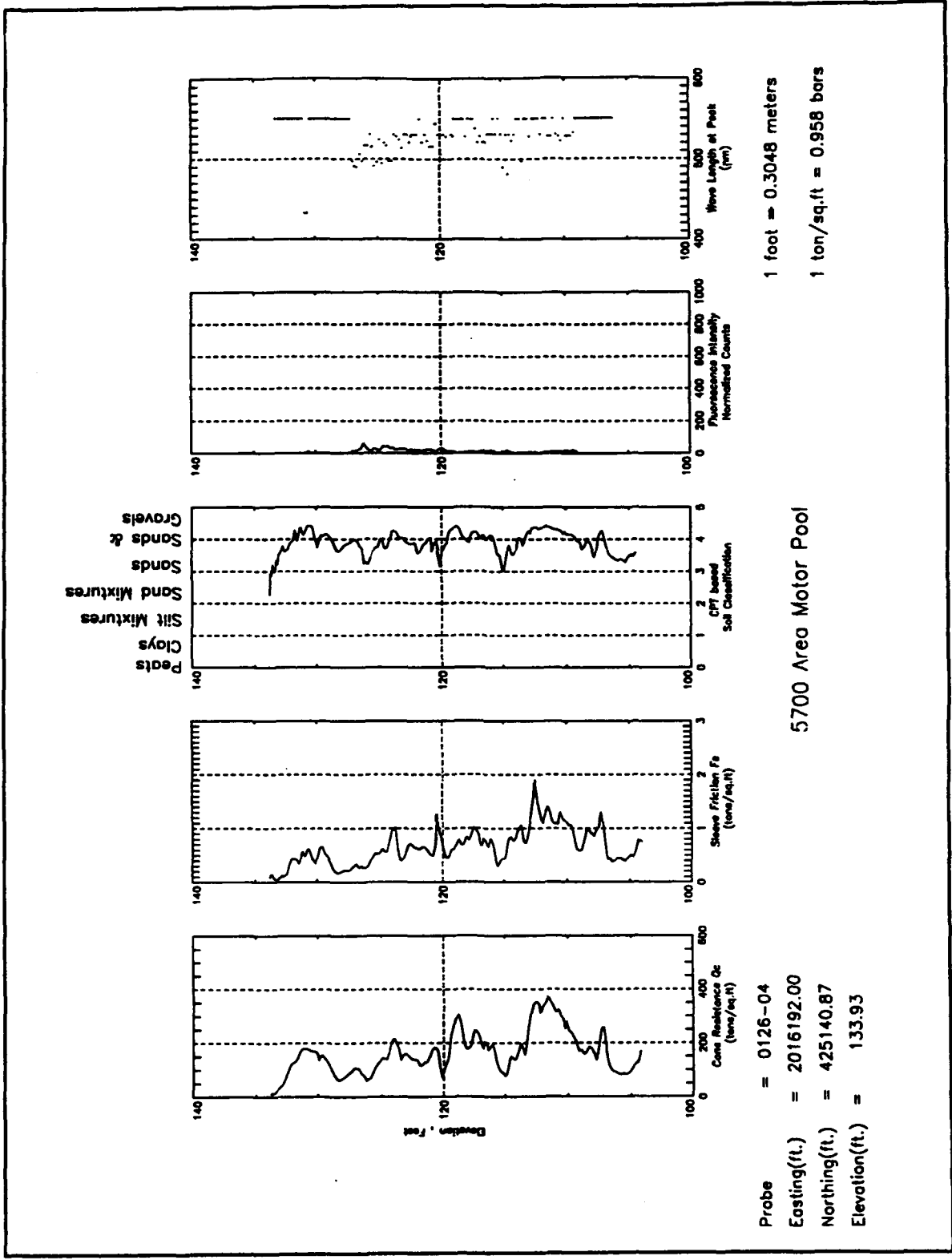

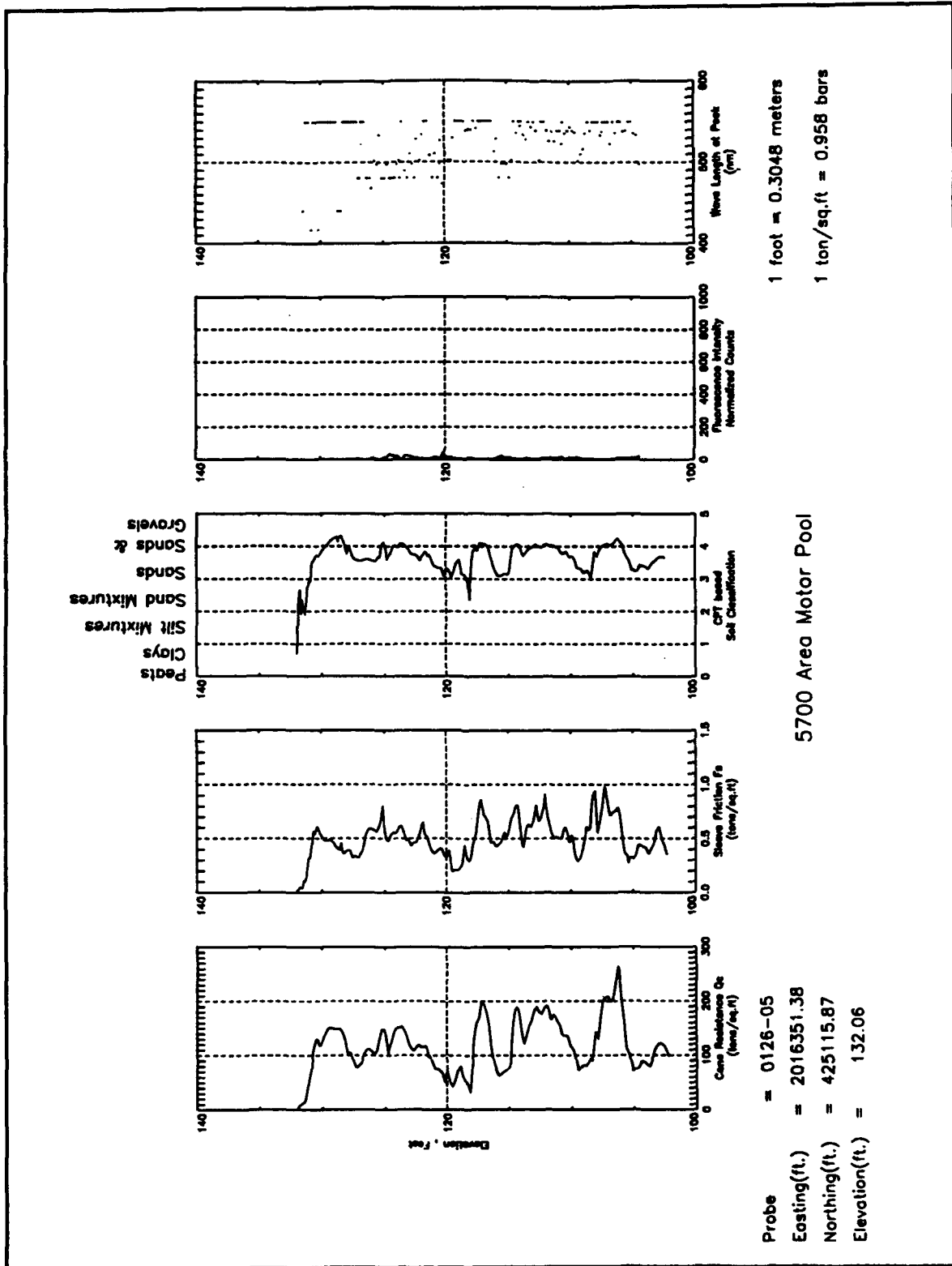

Appendix I

5800 Area Motor Pool

Verification Sample Information 5800 Area Motor Pool				
Sample No.	29286	29284	29521	29523
Type	Soil	Soil	Soil	Soil
Lab Method	418.1/415.1	418.1/415.1	8270	8270
TRPH, ppm	<25	<25		
Other, ppm	1905(TOC)	1347(TOC)	PAH-Table 11	PAH-Table 11
Easting, ft	2011794	2011794	2011794	2011794
Northing, ft	424014	424014	424014	424014
Elevation Range ft MSL	153-154	147-148	147-148	153-154
Sample Fluoresced?	NO	YES	YES	NO
Maximum Intensity counts	0	28	28	0
Peak Wavelength, nm	594	464	464	594
Nearest Probe	0129-05	0129-05	0129-05	0129-05
Easting, ft	2011792.6	2011792.6	2011792.6	2011792.6
Northing, ft	424012.6	424012.6	424012.6	424012.6
Offset from Sample, ft	2	2	2	2
Soil Classification at Sample Elevation	Sand	Sand/Gravel	Sand/Gravel	Sand
Intensity Range counts	0	90-100	90-100	0
Peak Wavelength, nm	590	520	520	590
<p>TRPH = Total Recoverable Petroleum Hydrocarbons. PAH = Polynuclear Aromatic Hydrocarbons. TOC = Total Organic Carbon. OG = Oil and Grease. ppm = parts per million. Lab Method = USEPA SW-846, 1984.</p>				

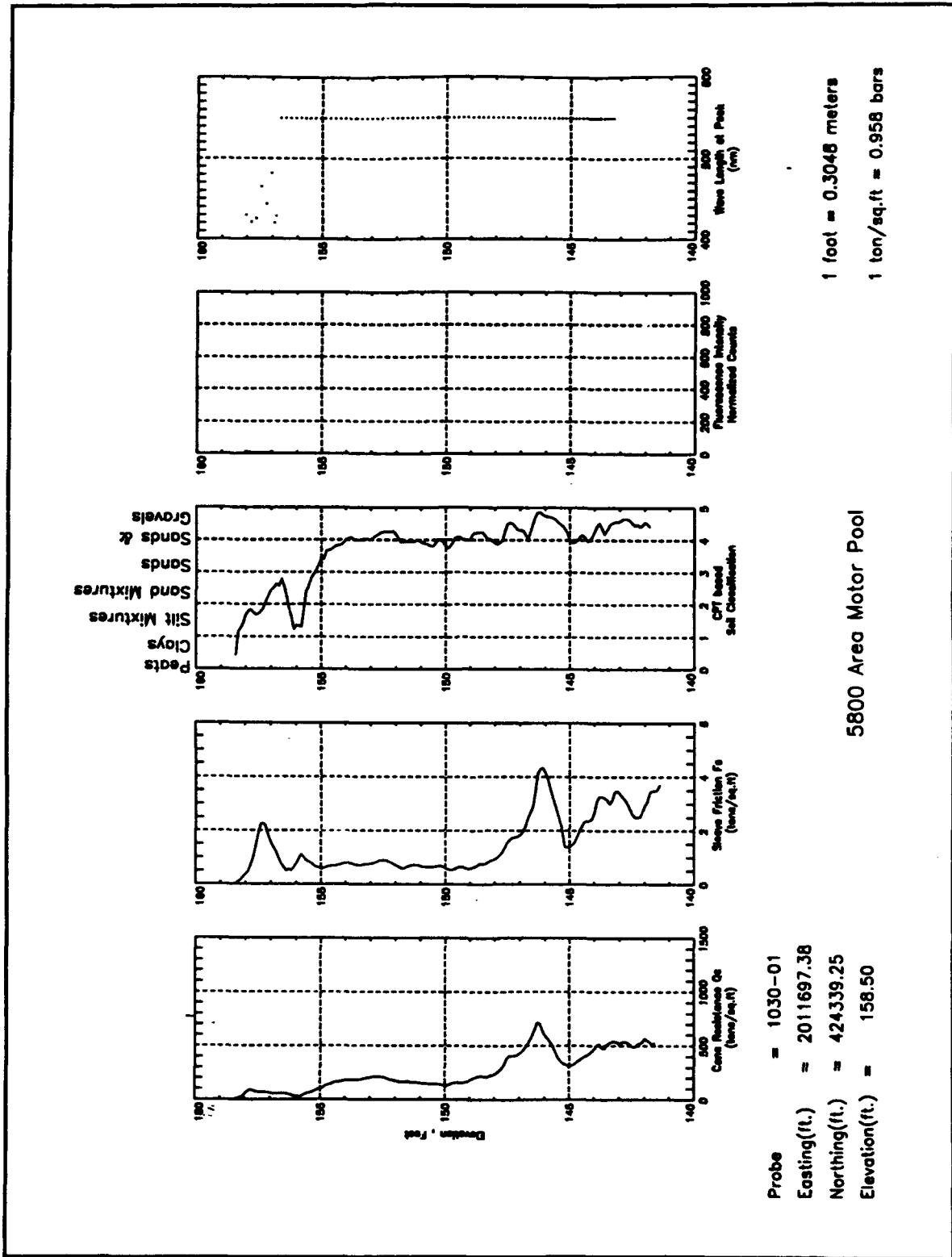

Probe = 1030-01
 Easting(ft.) = 2011697.38
 Northing(ft.) = 424339.25
 Elevation(ft.) = 158.50

5800 Area Motor Pool

1 foot = 0.3048 meters
 1 ton/sq.ft = 0.958 bars

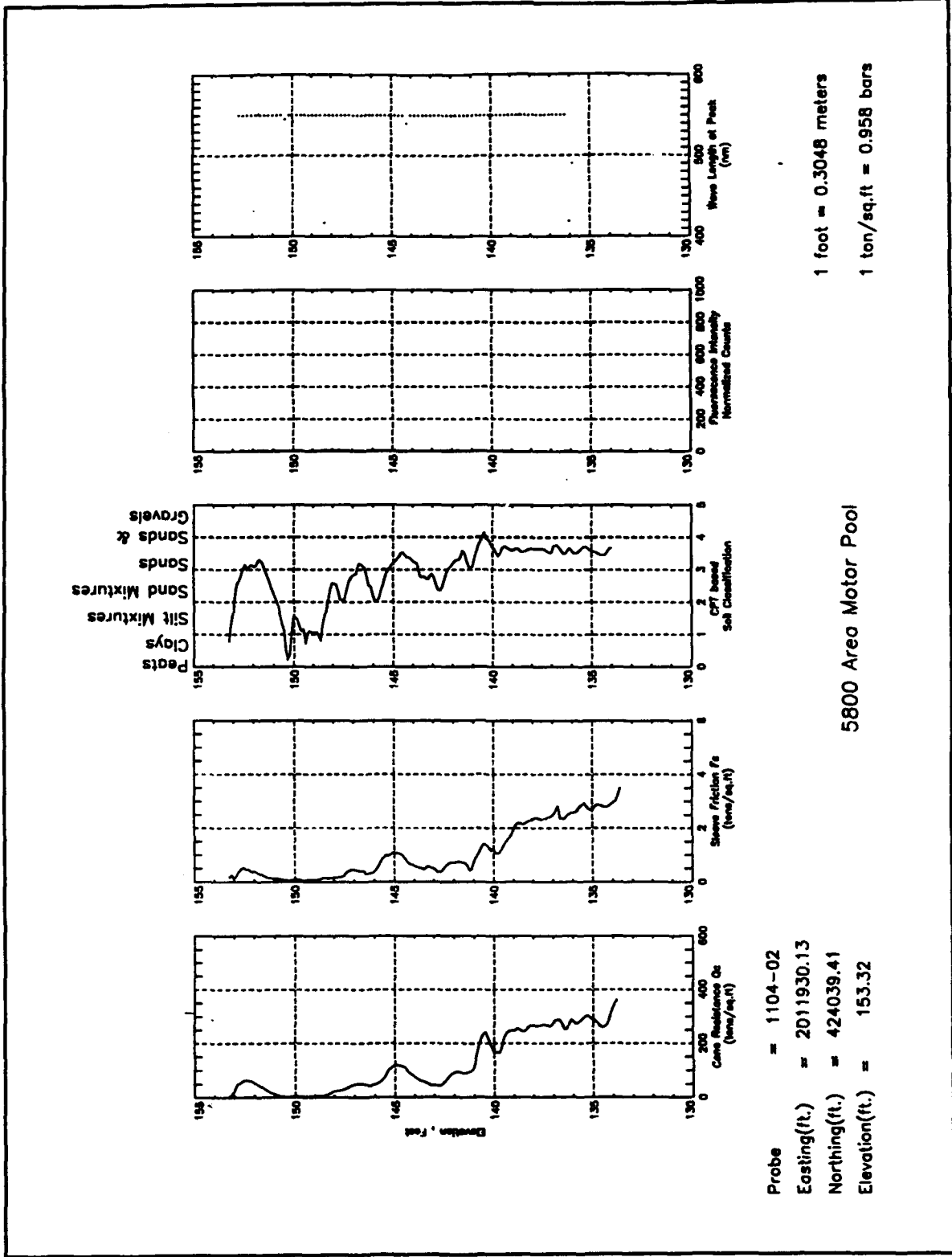

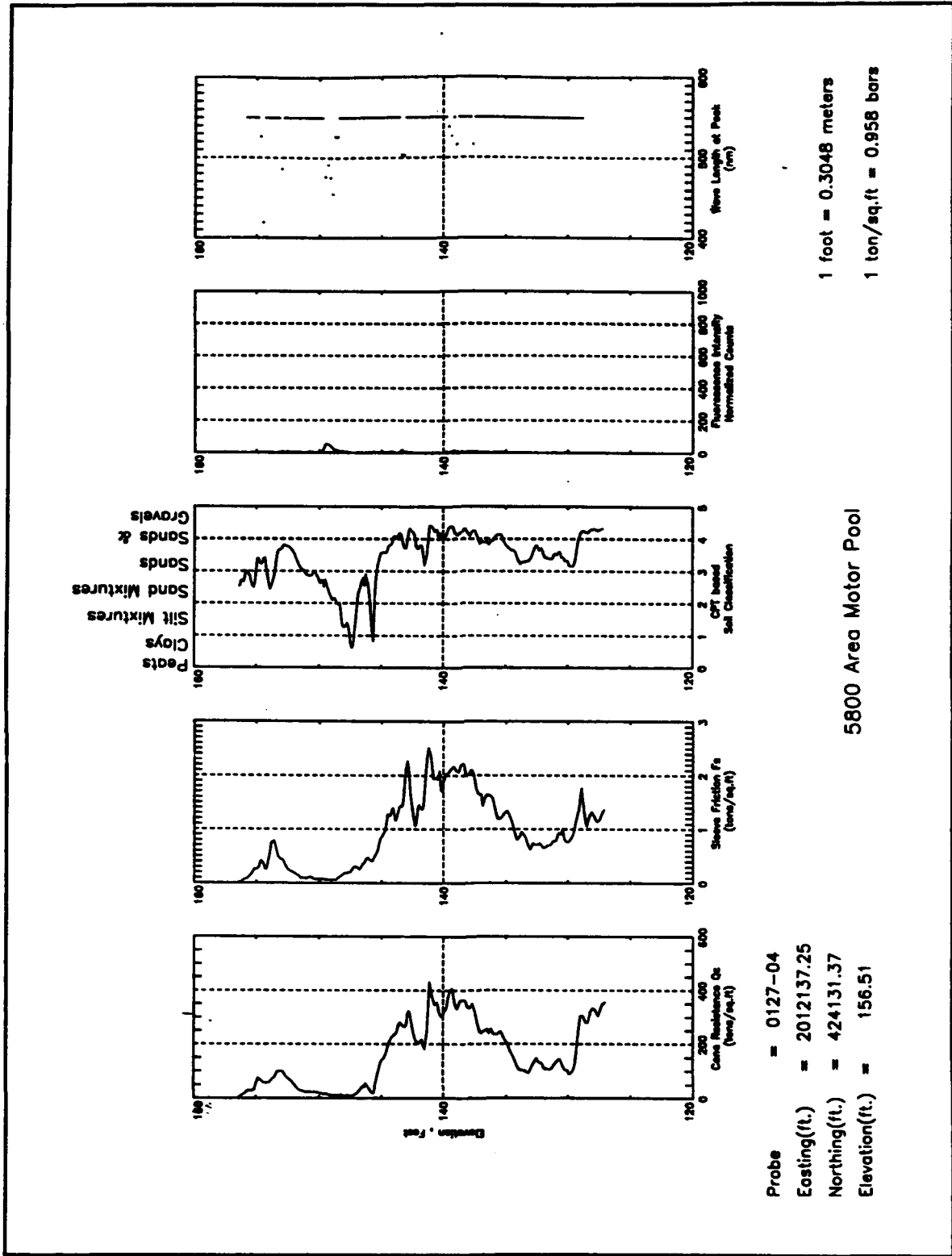

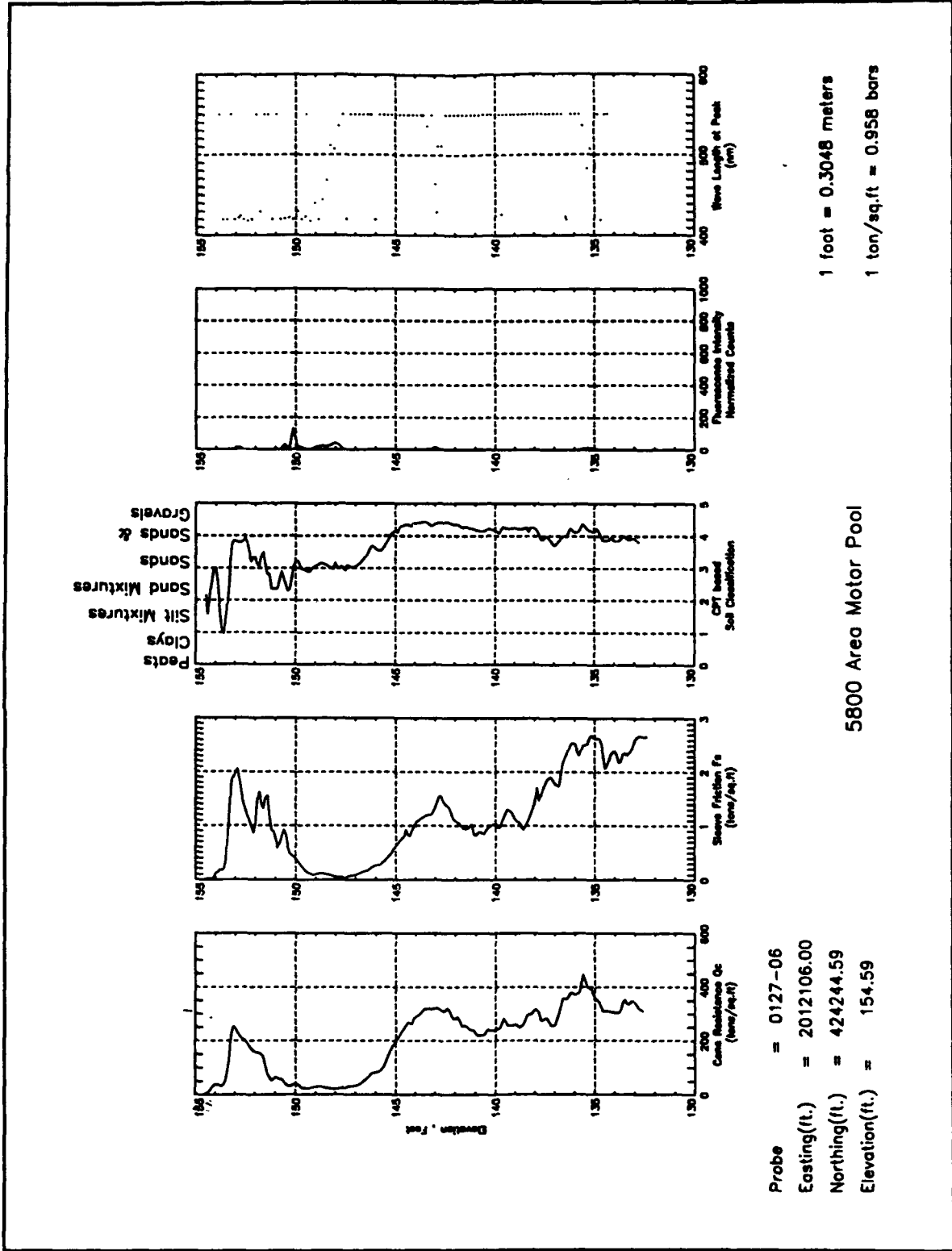

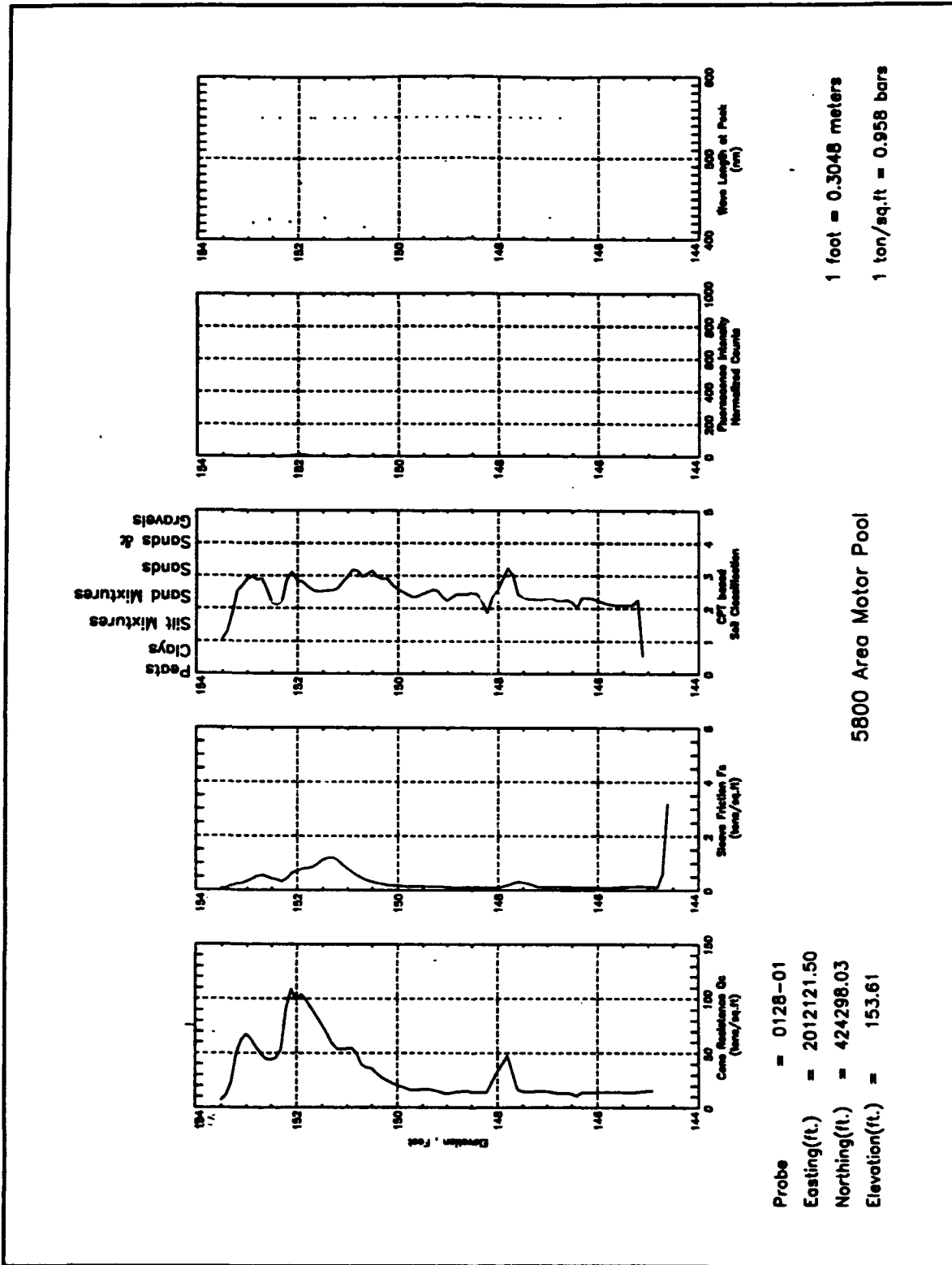

Probe = 0128-01
 Easting(ft.) = 2012121.50
 Northing(ft.) = 424298.03
 Elevation(ft.) = 153.61

1 foot = 0.3048 meters
 1 ton/sq.ft = 0.958 bars

5800 Area Motor Pool

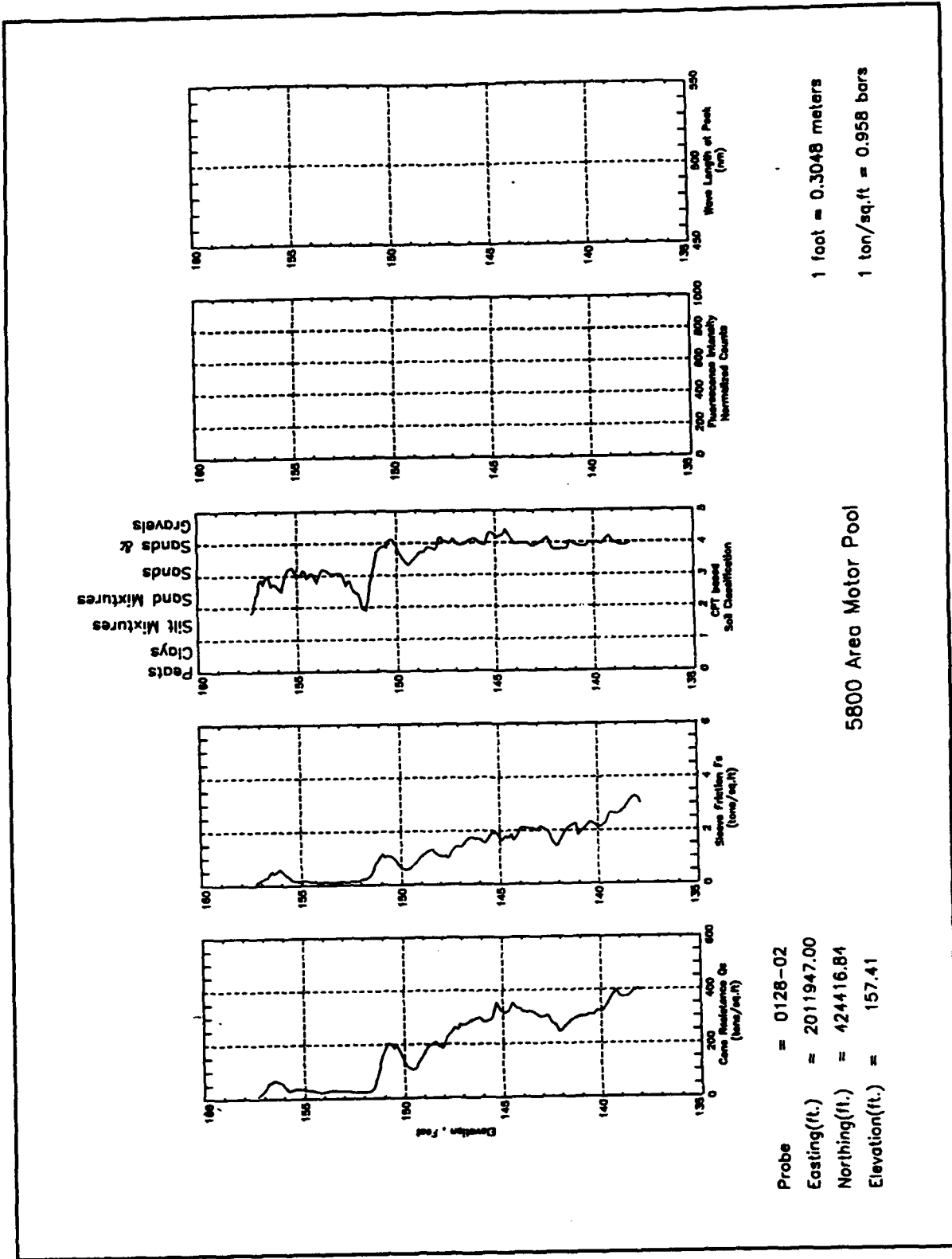

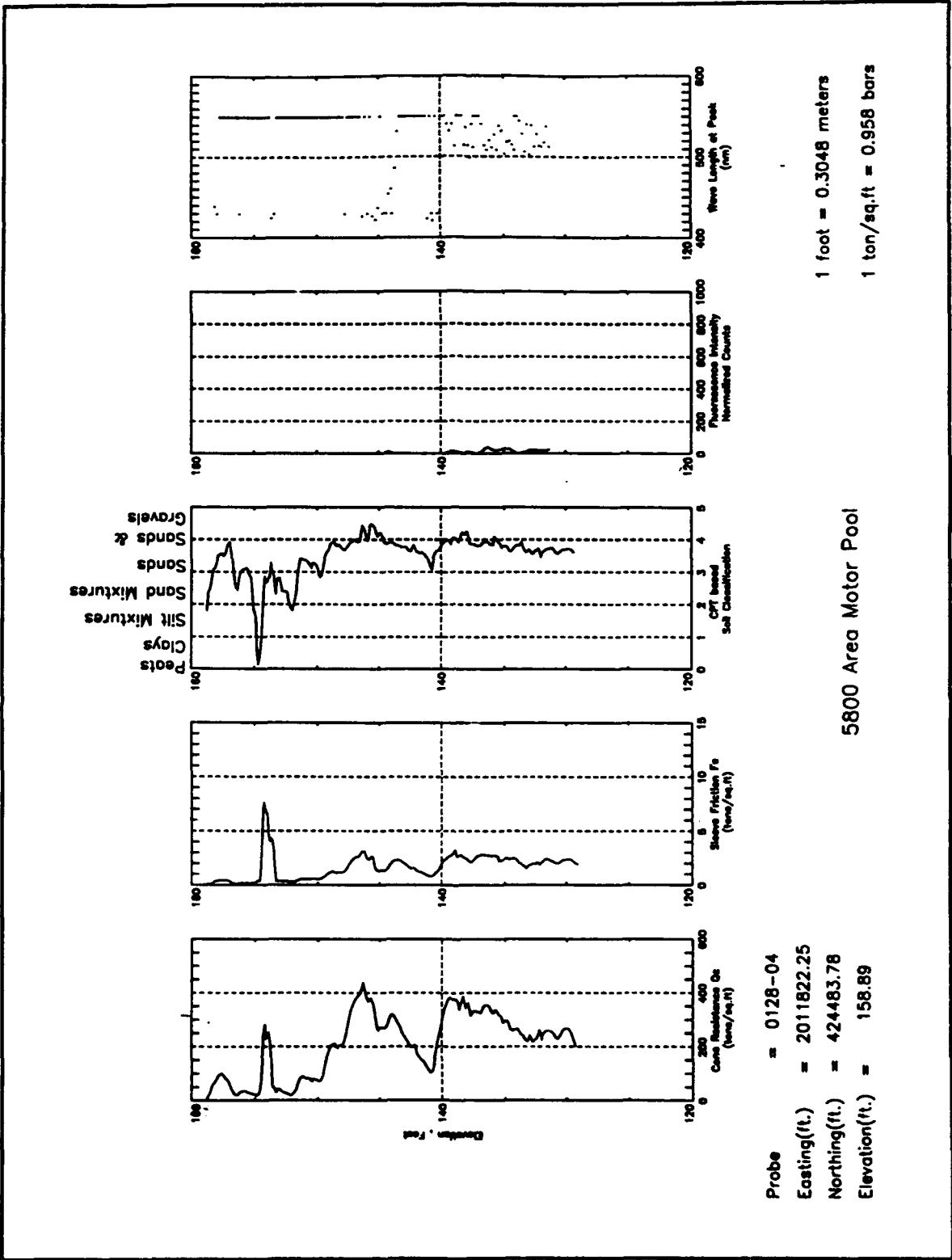

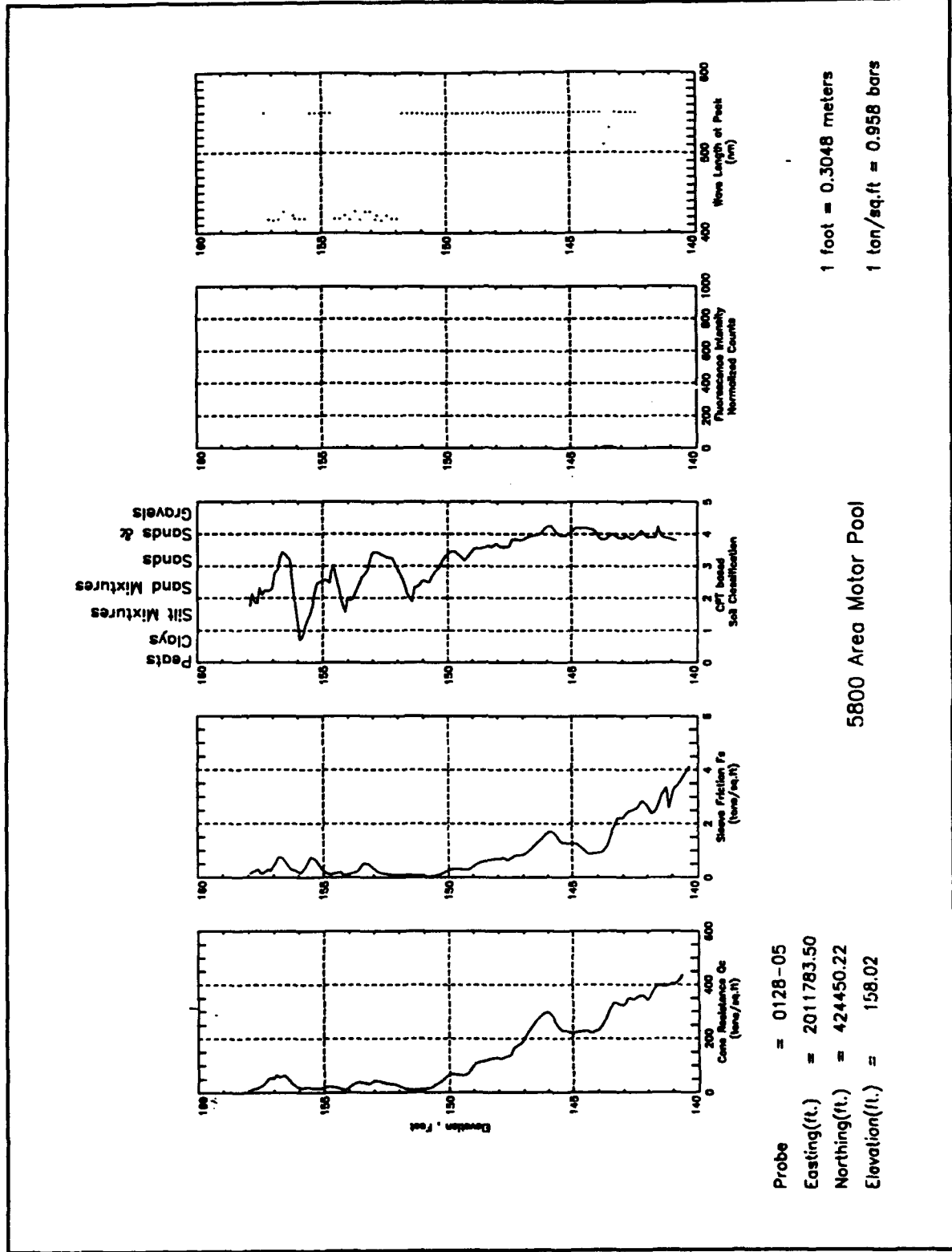

Probe = 0128-05
 Easting(ft.) = 2011783.50
 Northing(ft.) = 424450.22
 Elevation(ft.) = 158.02

1 foot = 0.3048 meters
 1 ton/sq.ft = 0.958 bars

5800 Area Motor Pool

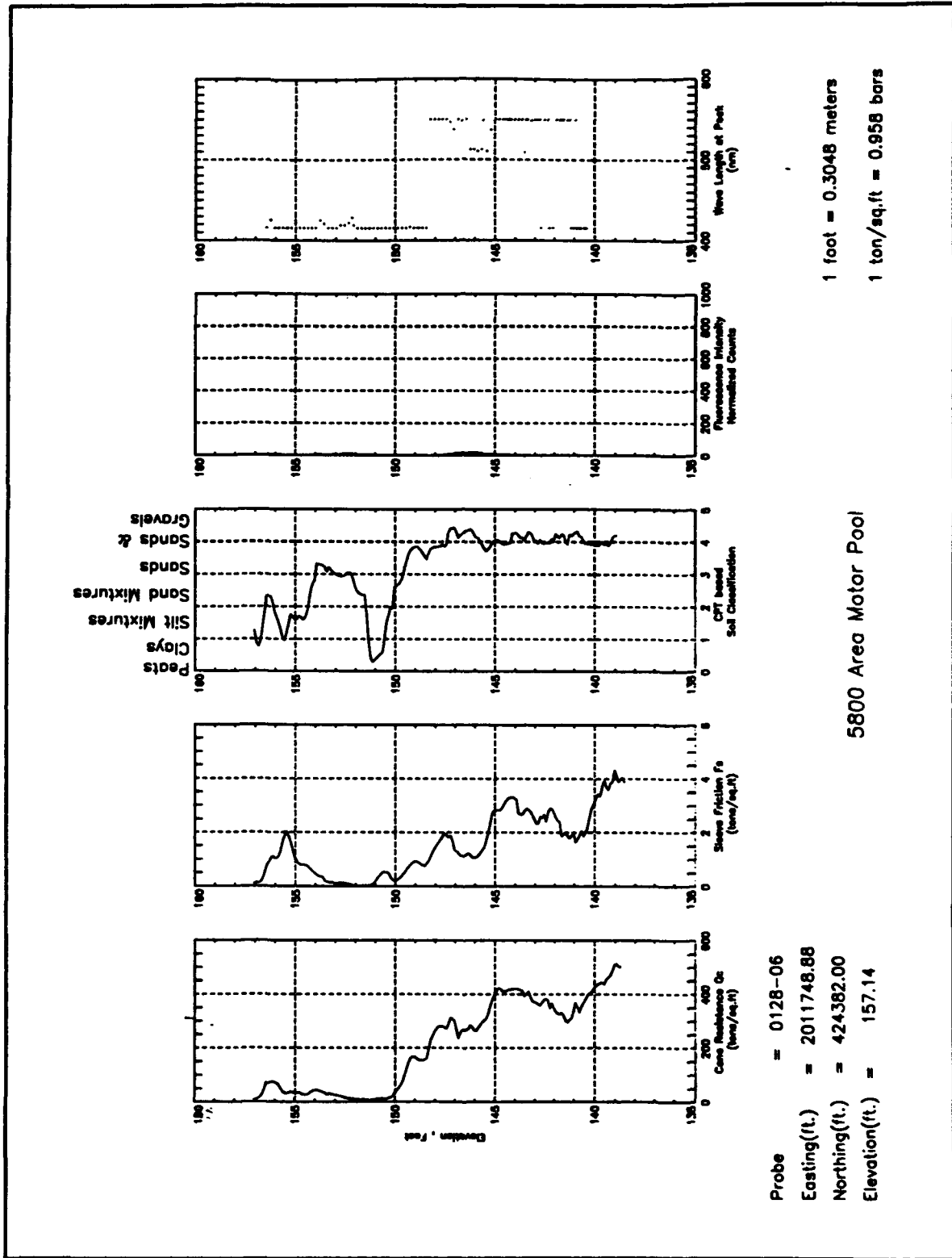

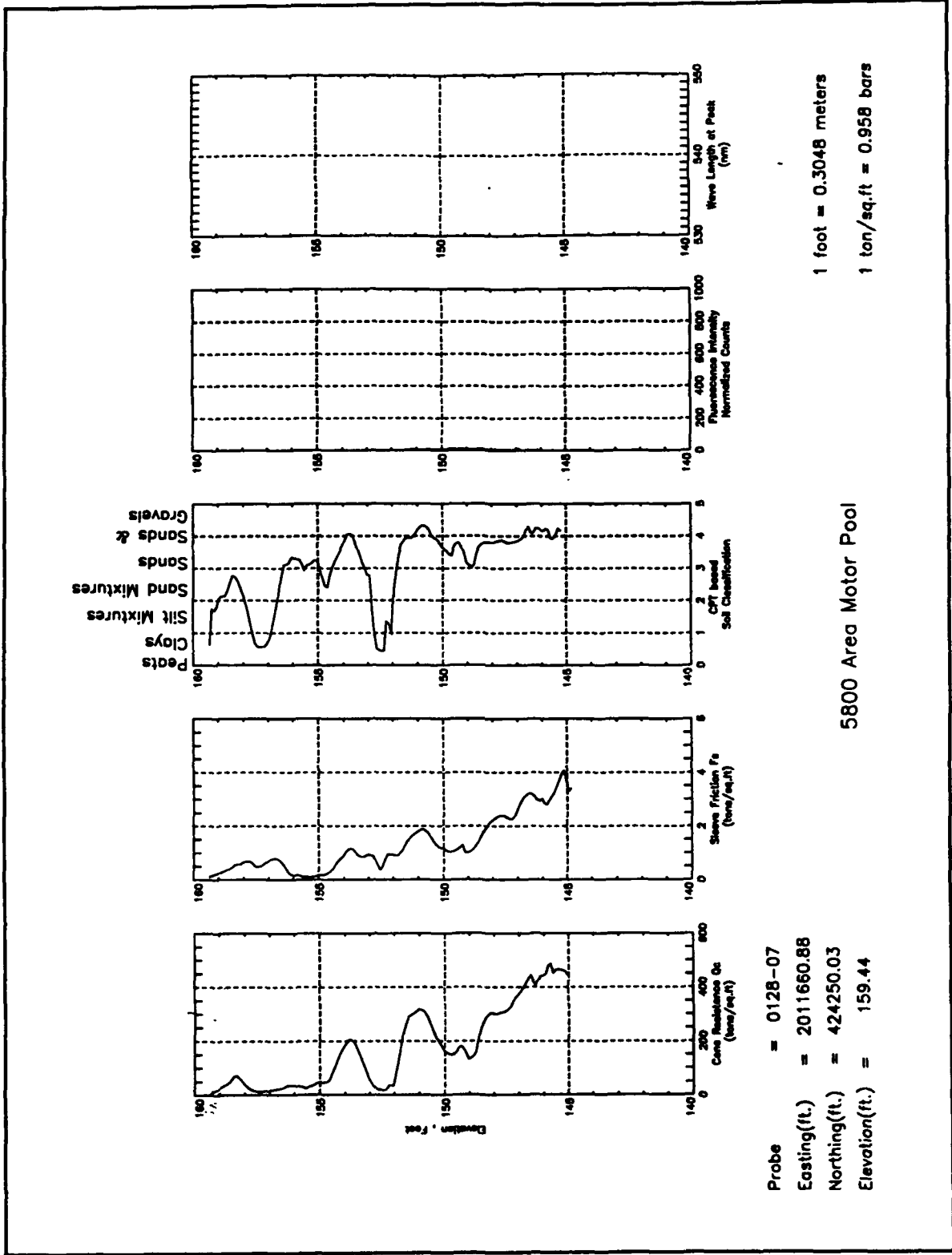

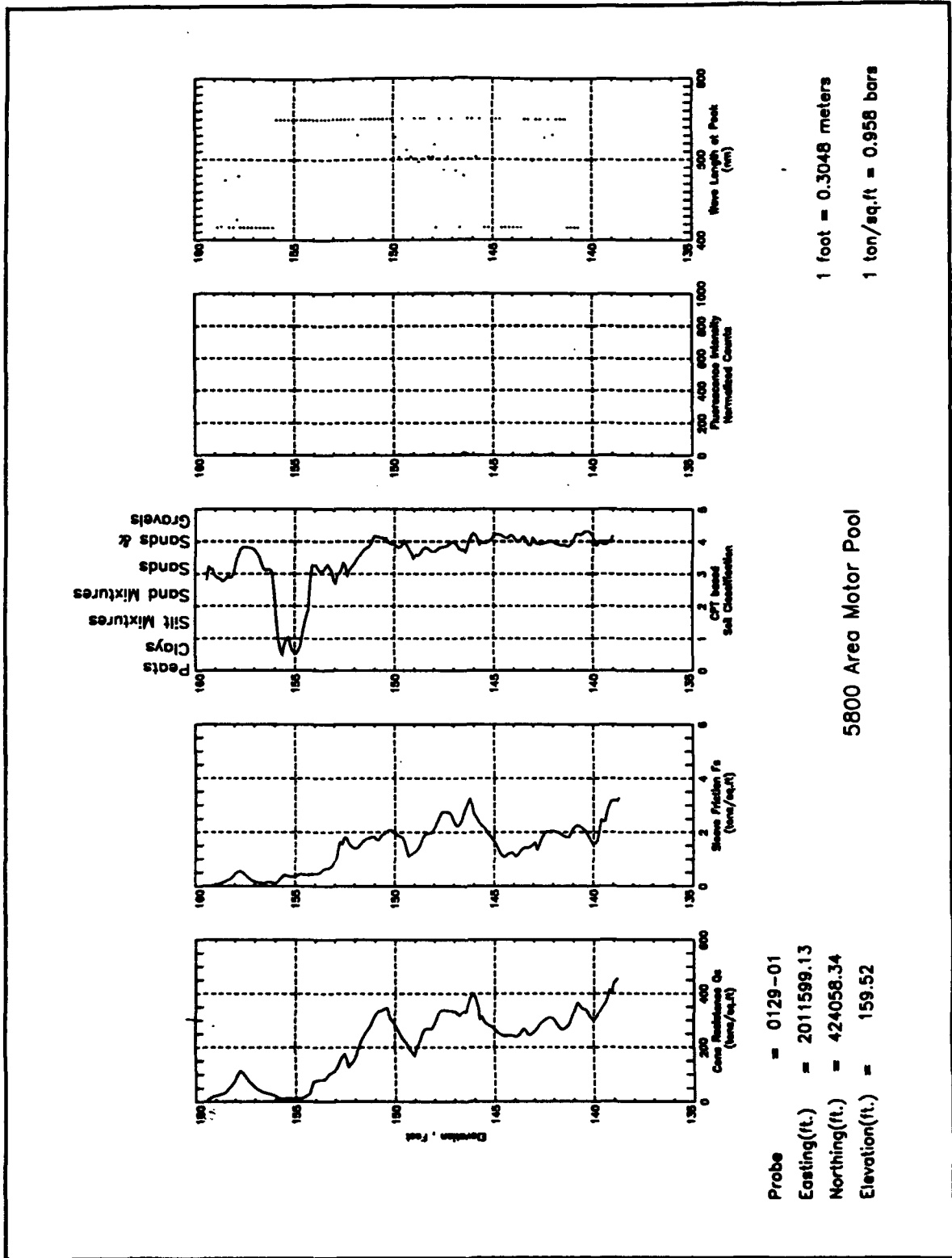

Probe = 0129-01
 Easting(ft.) = 2011599.13
 Northing(ft.) = 424058.34
 Elevation(ft.) = 159.52

1 foot = 0.3048 meters
 1 ton/sq.ft = 0.958 bars

5800 Area Motor Pool

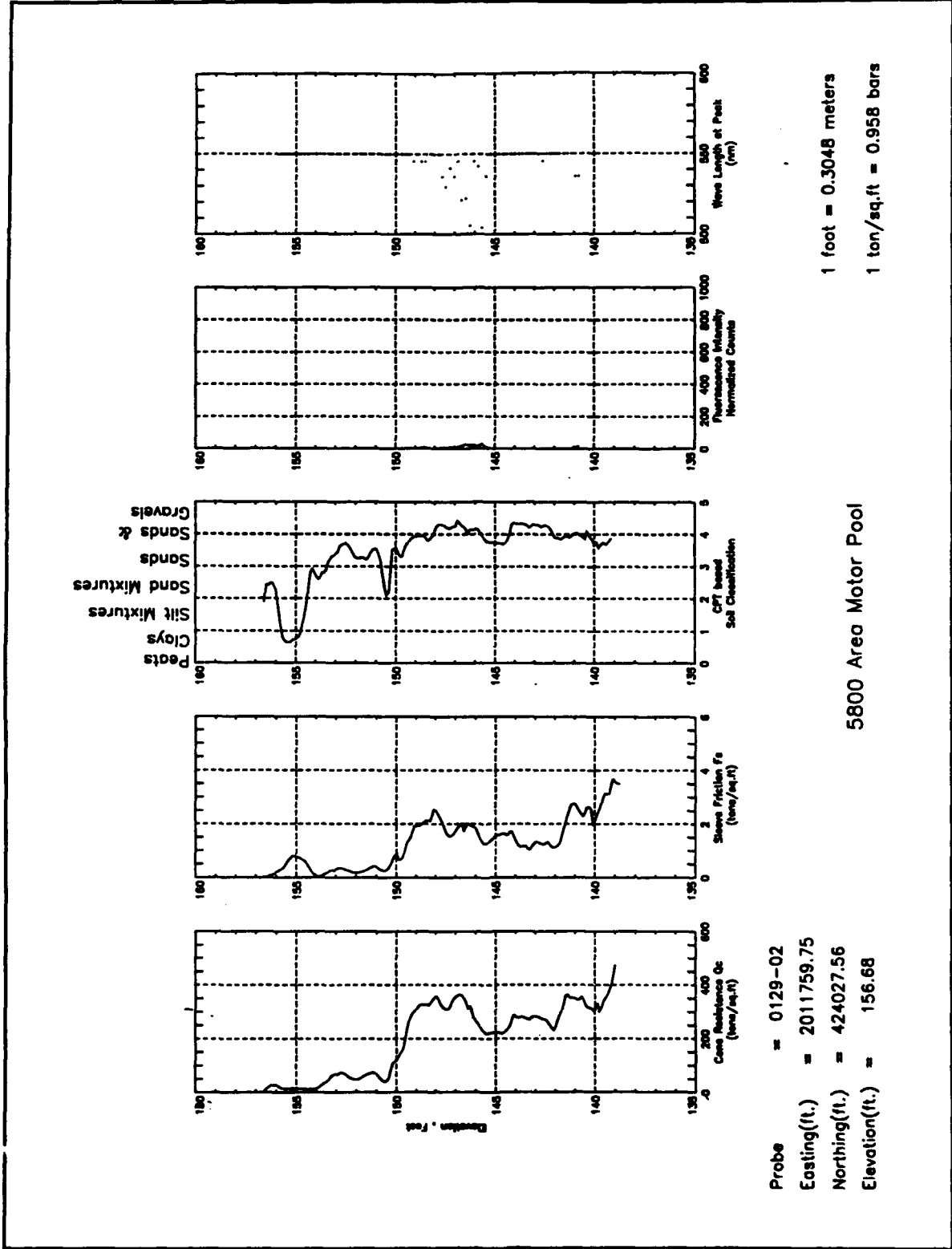

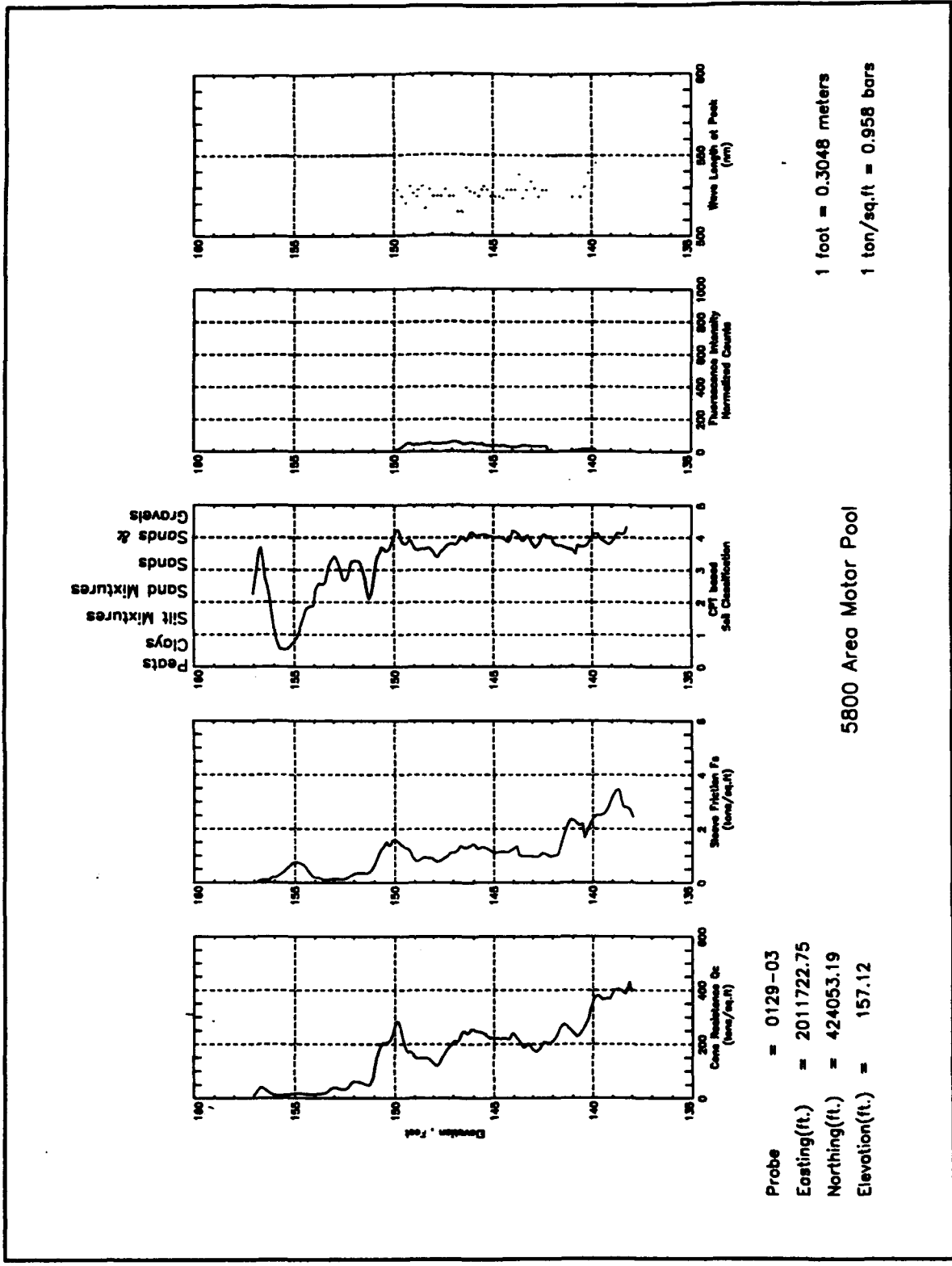

Probe = 0129-03
 Easting(ft.) = 2011722.75
 Northing(ft.) = 424053.19
 Elevation(ft.) = 157.12

5800 Area Motor Pool

1 foot = 0.3048 meters
 1 ton/sq.ft = 0.958 bars

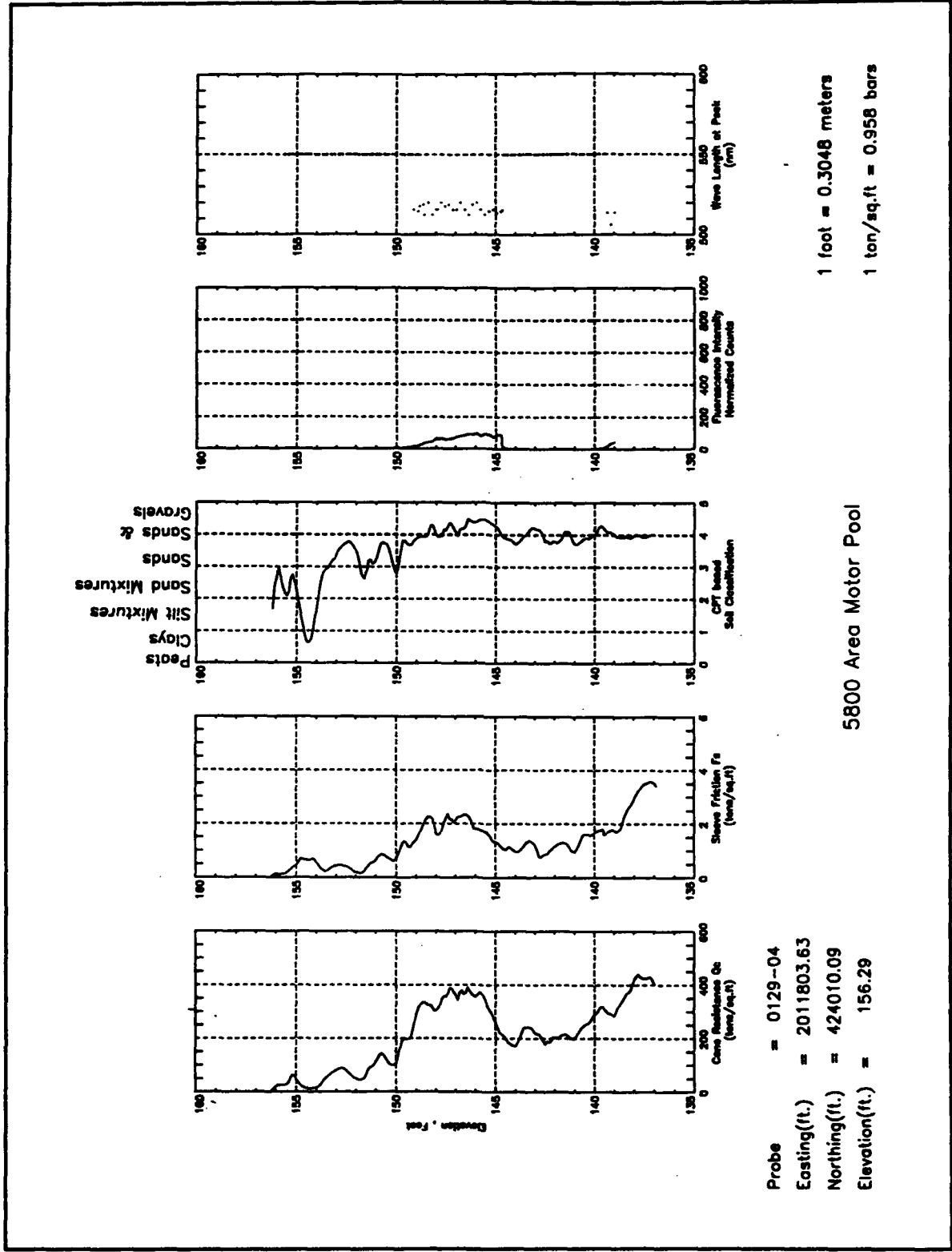

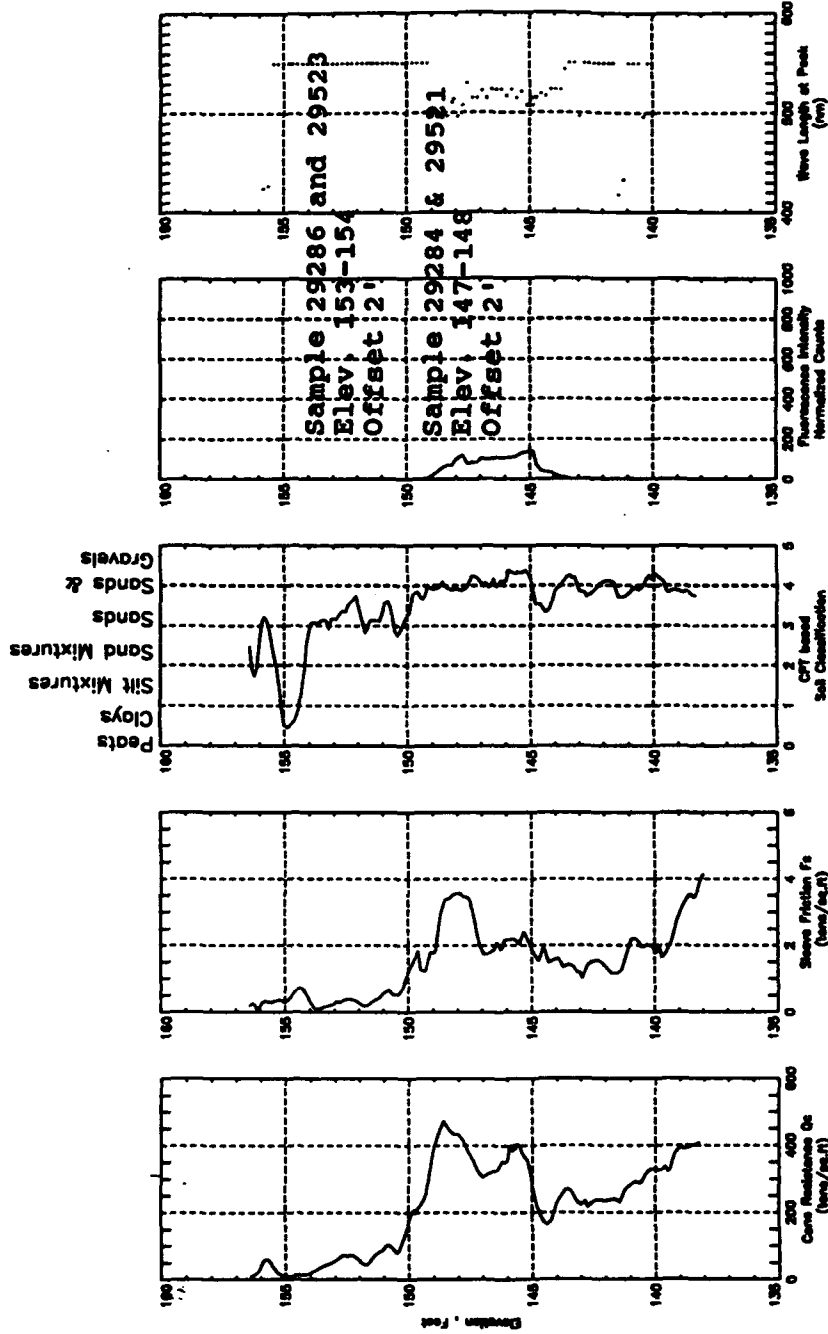

Probe = 0129-05
 Easting(ft.) = 2011792.63
 Northing(ft.) = 424012.56
 Elevation(ft.) = 156.51

1 foot = 0.3048 meters
 1 ton/sq.ft = 0.958 bars

5800 Area Motor Pool

Appendix J

5881 Boiler Plant and Incinerator

Verification Sample Information 5881 Boiler Plant and Incinerator				
Sample No.	29285	29517		
Type	Soil	Soil		
Lab Method	418.1/415.1	8270		
TRPH, ppm	<25			
Other, ppm	1720(TOC)	PAH-Table 13		
Easting, ft	2012061	2012061		
Northing, ft	423919	423919		
Elevation Range ft MSL	143-144	143-144		
Sample Fluoresced?	YES	YES		
Maximum Intensity counts	16	16		
Peak Wavelength, nm	422	422		
Nearest Probe	0201-03	0201-03		
Easting, ft	2012060	2012060		
Northing, ft	423918.1	423918.1		
Offset from Sample, ft	2	2		
Soil Classification at Sample Elevation	Sand/Gravel	Sand/Gravel		
Intensity Range counts	100-150	100-150		
Peak Wavelength, nm	520	520		
<p>TRPH = Total Recoverable Petroleum Hydrocarbons. PAH = Polynuclear Aromatic Hydrocarbons. TOC = Total Organic Carbon. OG = Oil and Grease. ppm = parts per million. Lab Method = USEPA SW-846, 1984.</p>				

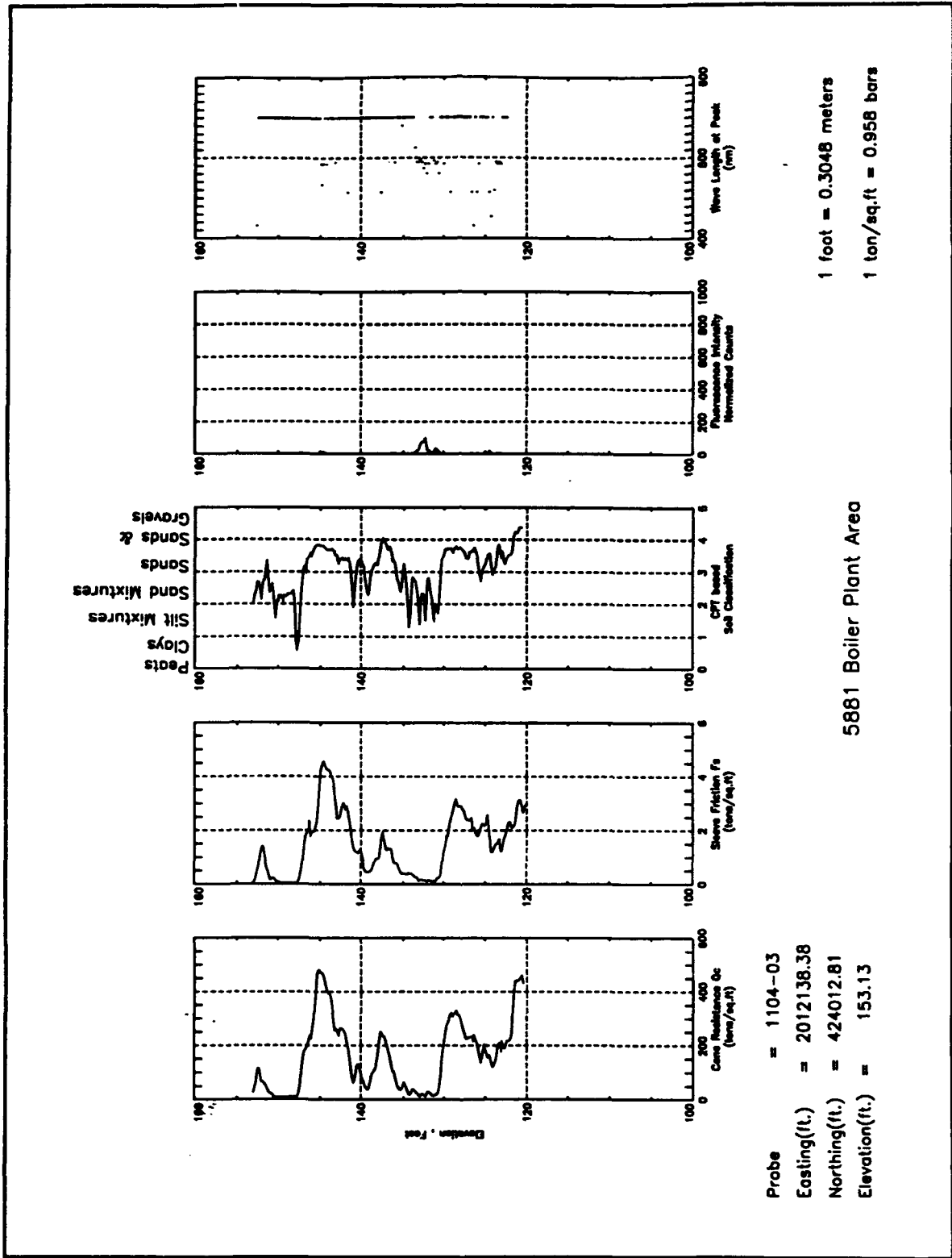

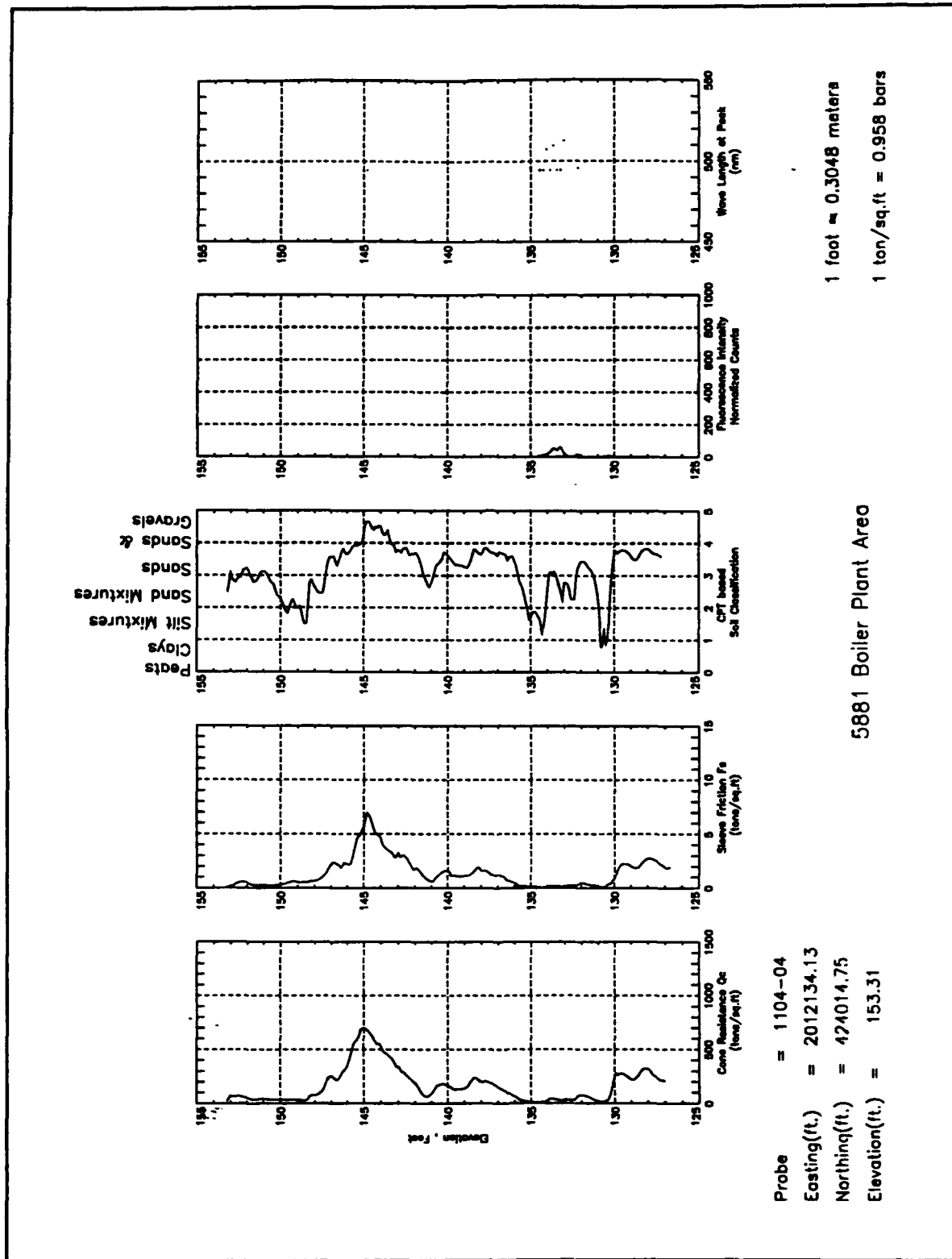

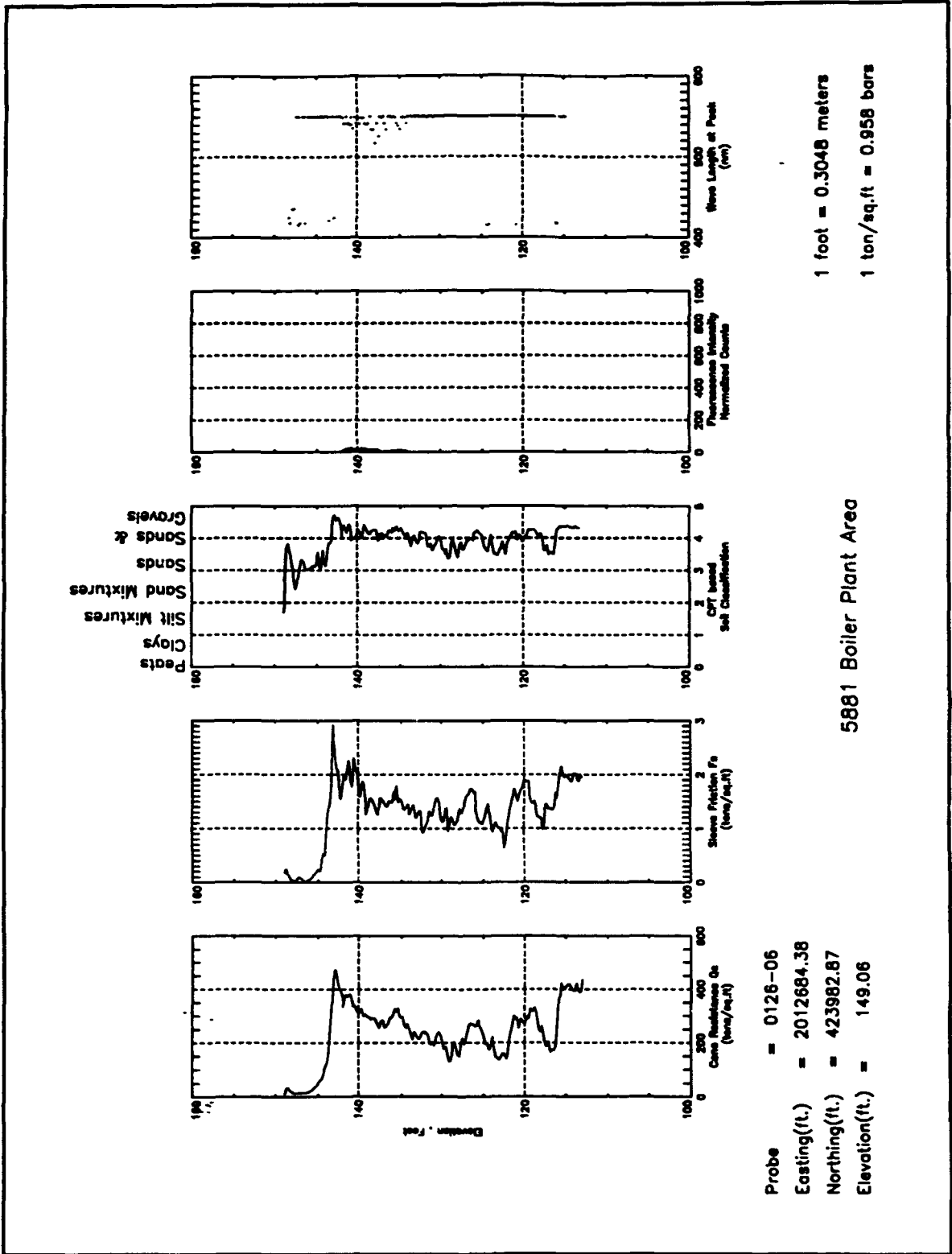

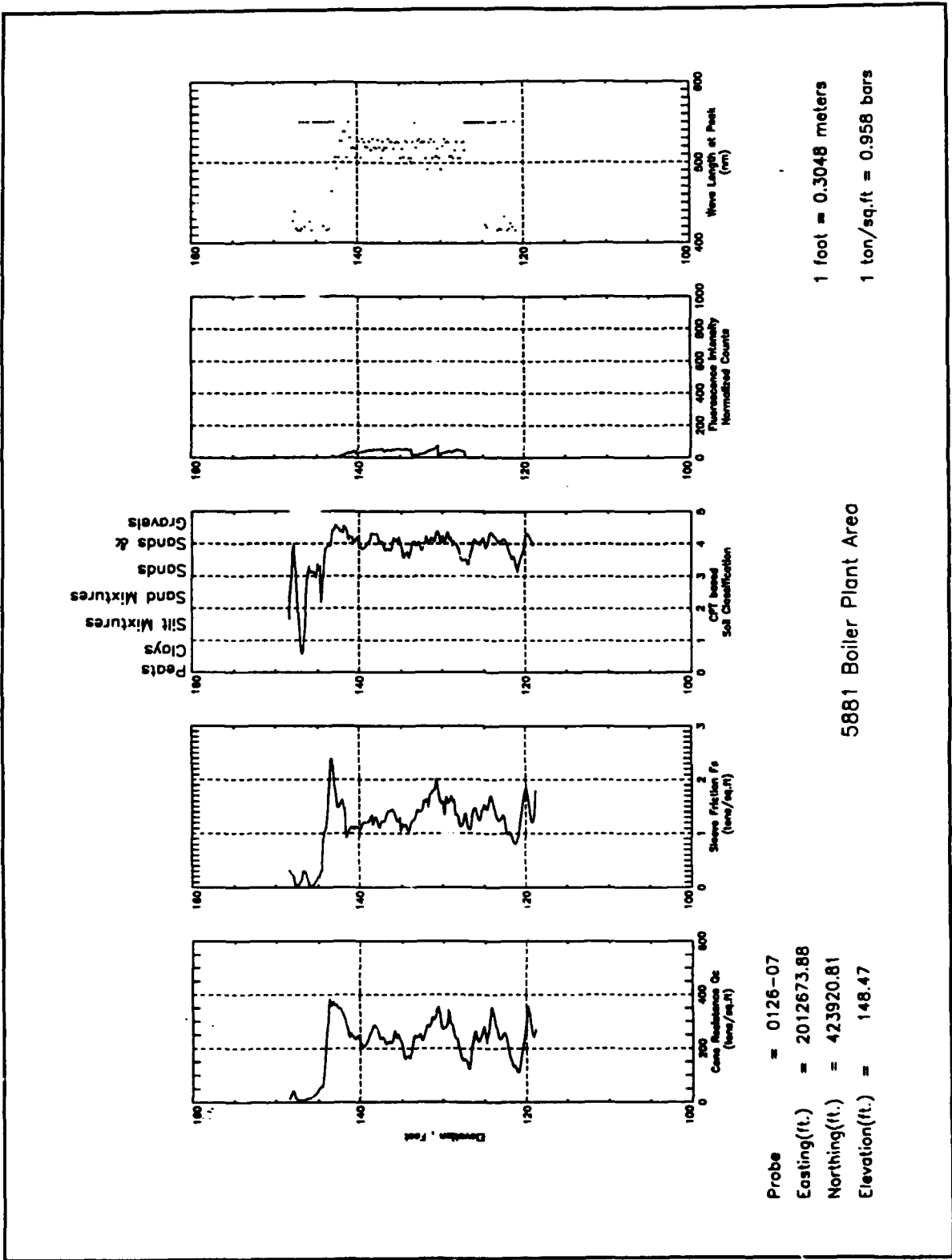

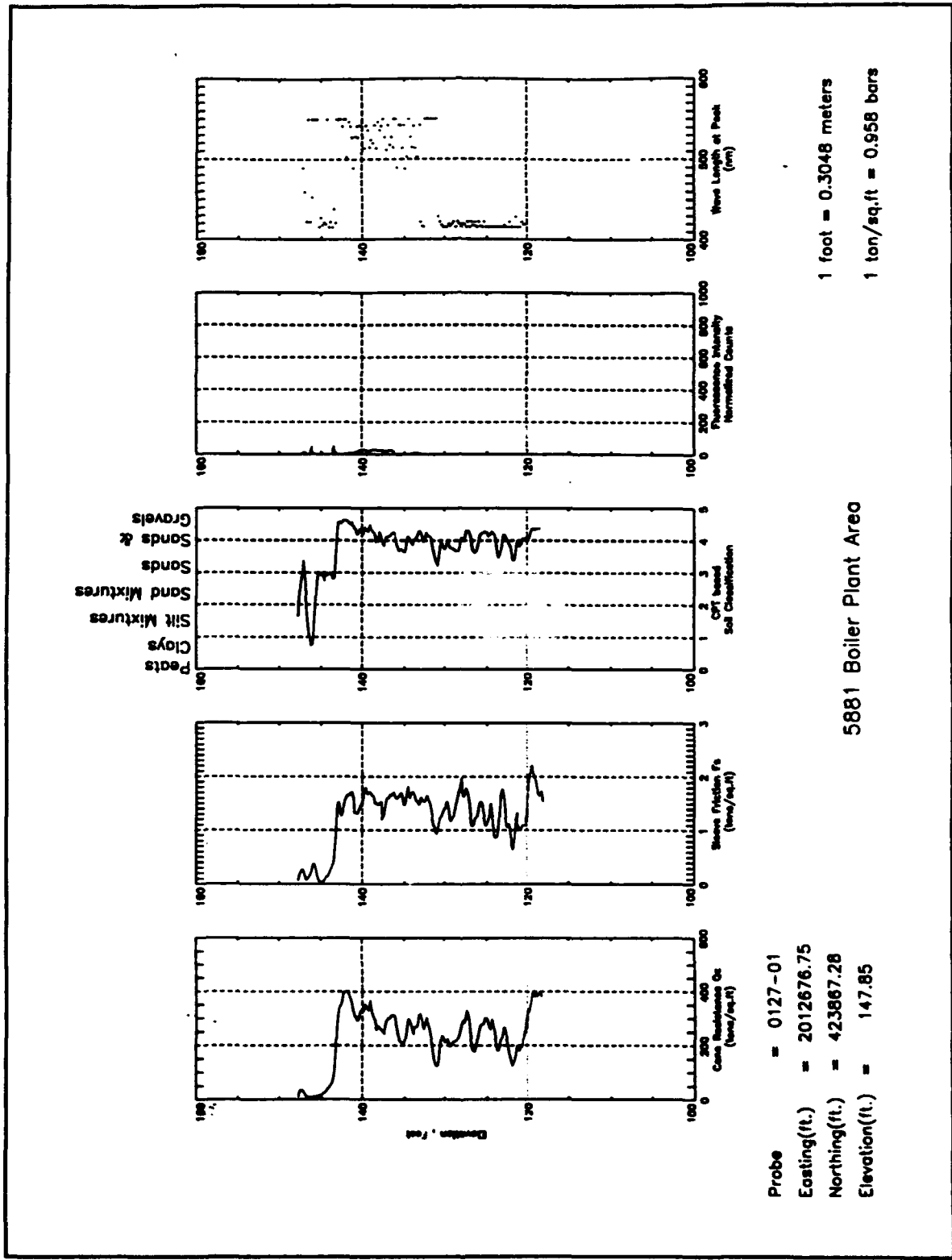

Probe = 0127-01
 Easting(ft.) = 2012676.75
 Northing(ft.) = 423867.28
 Elevation(ft.) = 147.85

5881 Boiler Plant Area

1 foot = 0.3048 meters
 1 ton/sq.ft = 0.958 bars

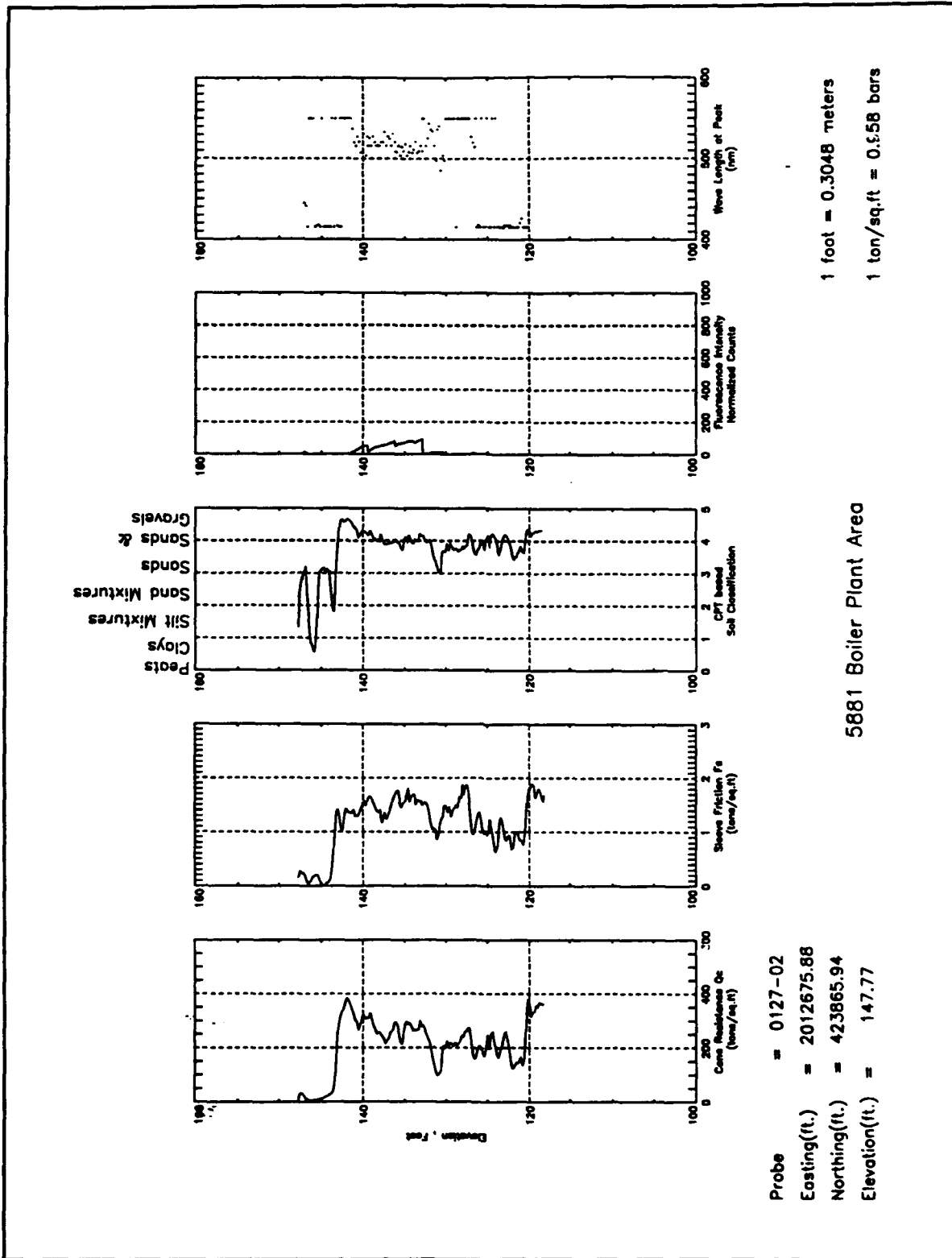

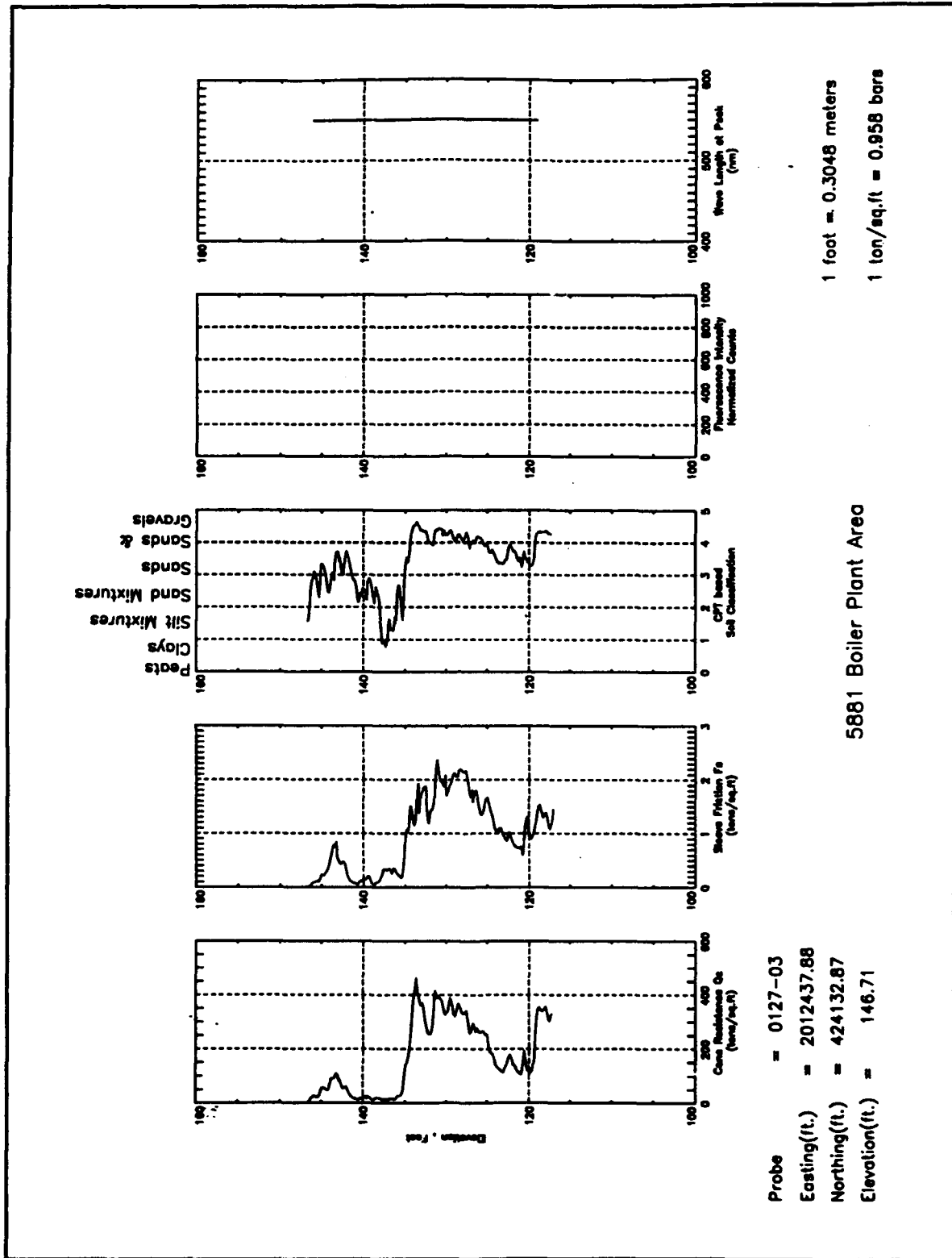

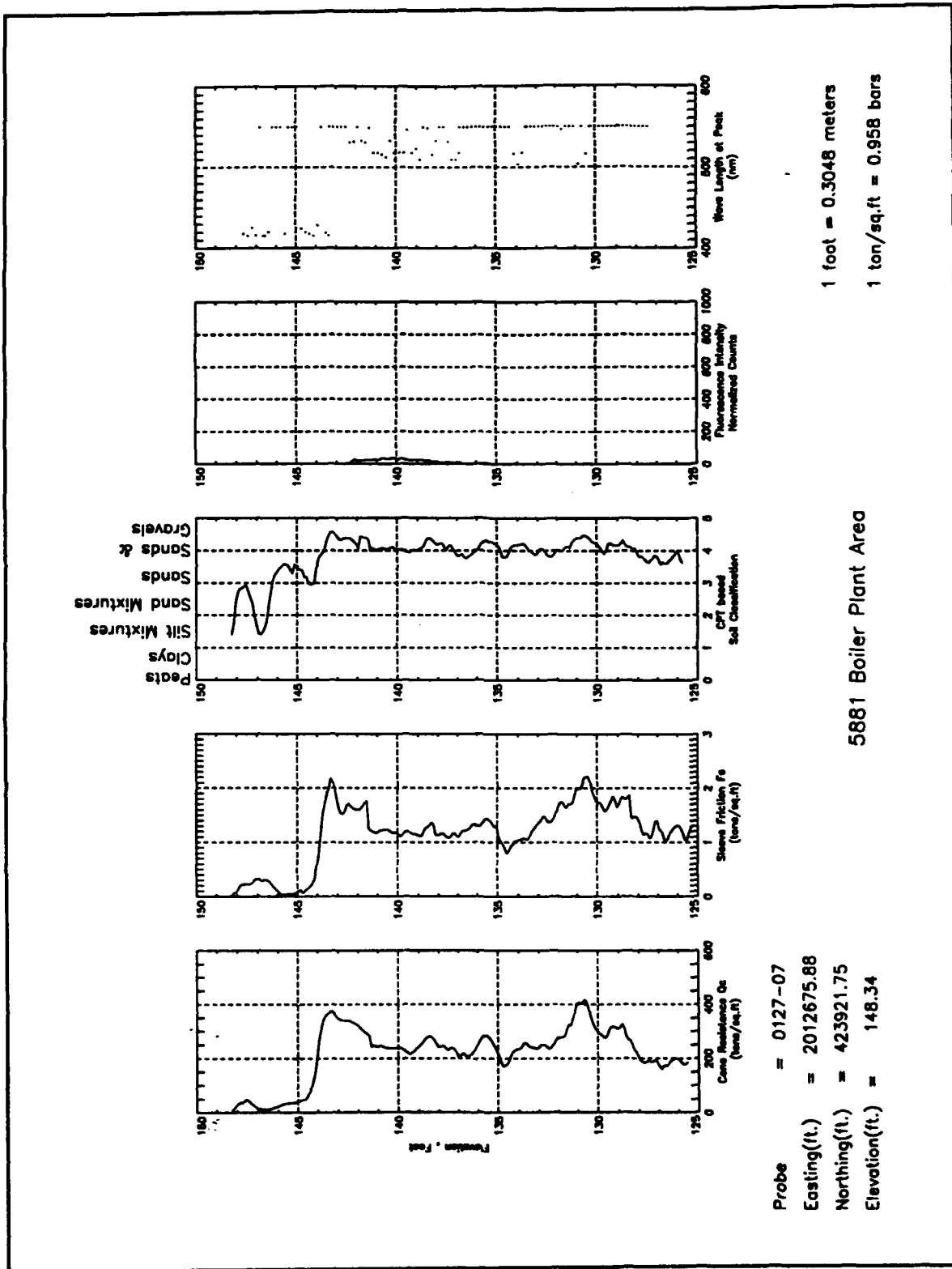

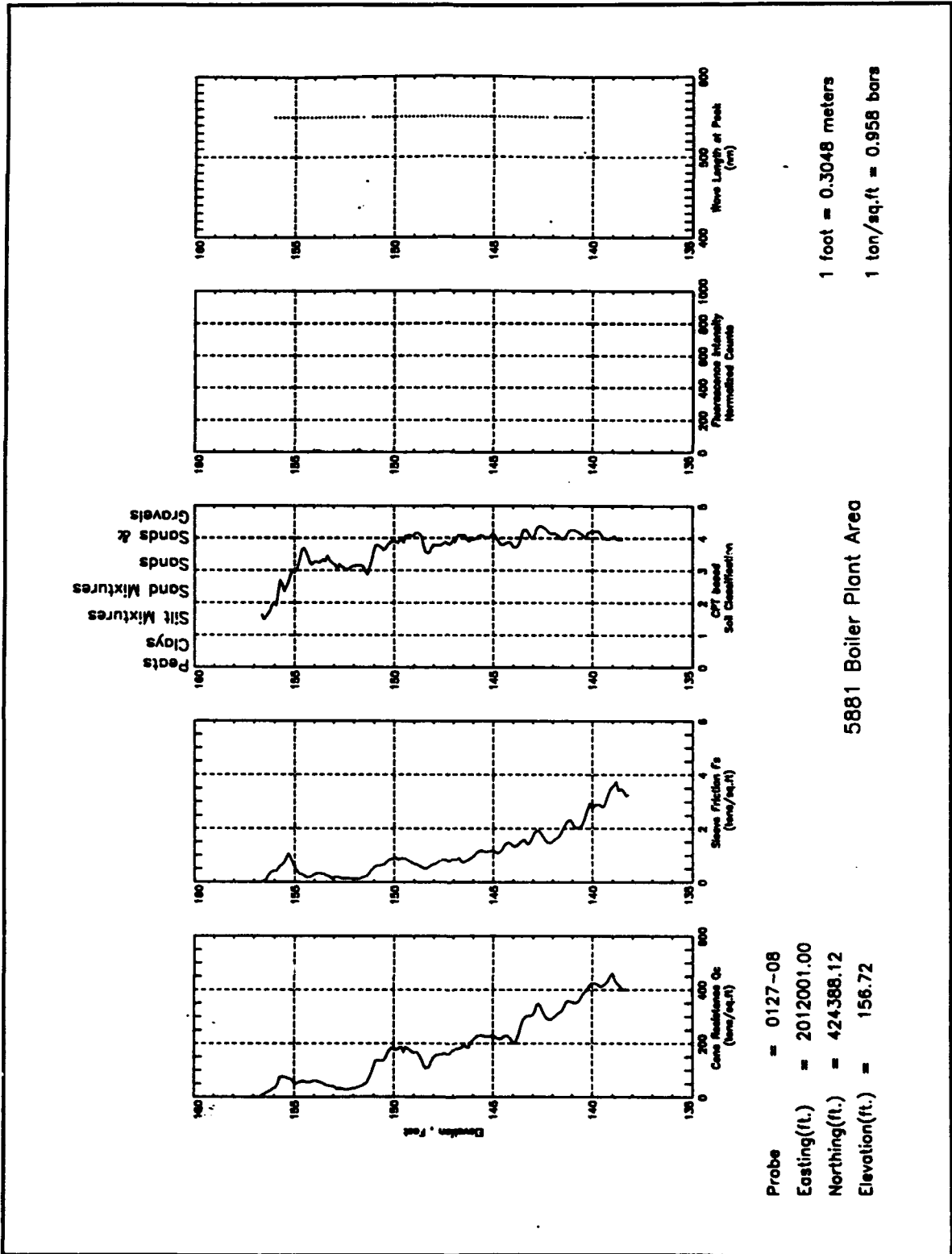

Probe = 0127-08
 Easting(ft.) = 2012001.00
 Northing(ft.) = 424388.12
 Elevation(ft.) = 156.72

5881 Boiler Plant Area

1 foot = 0.3048 meters
 1 ton/sq.ft = 0.958 bars

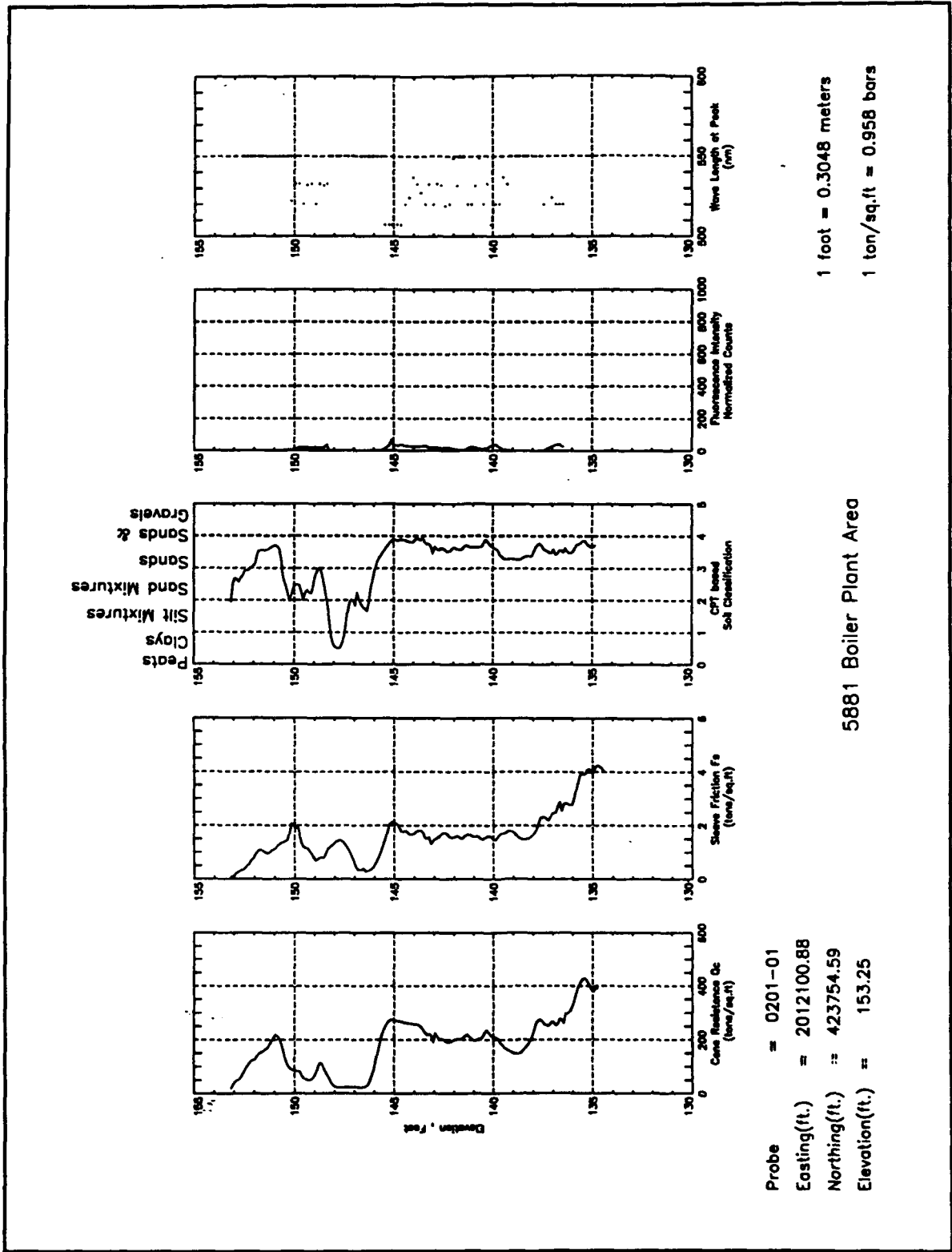

Probe = 0201-01
 Easting(ft.) = 2012100.88
 Northing(ft.) = 423754.59
 Elevation(ft.) = 153.25

1 foot = 0.3048 meters
 1 ton/sq.ft = 0.958 bars

5881 Boiler Plant Area

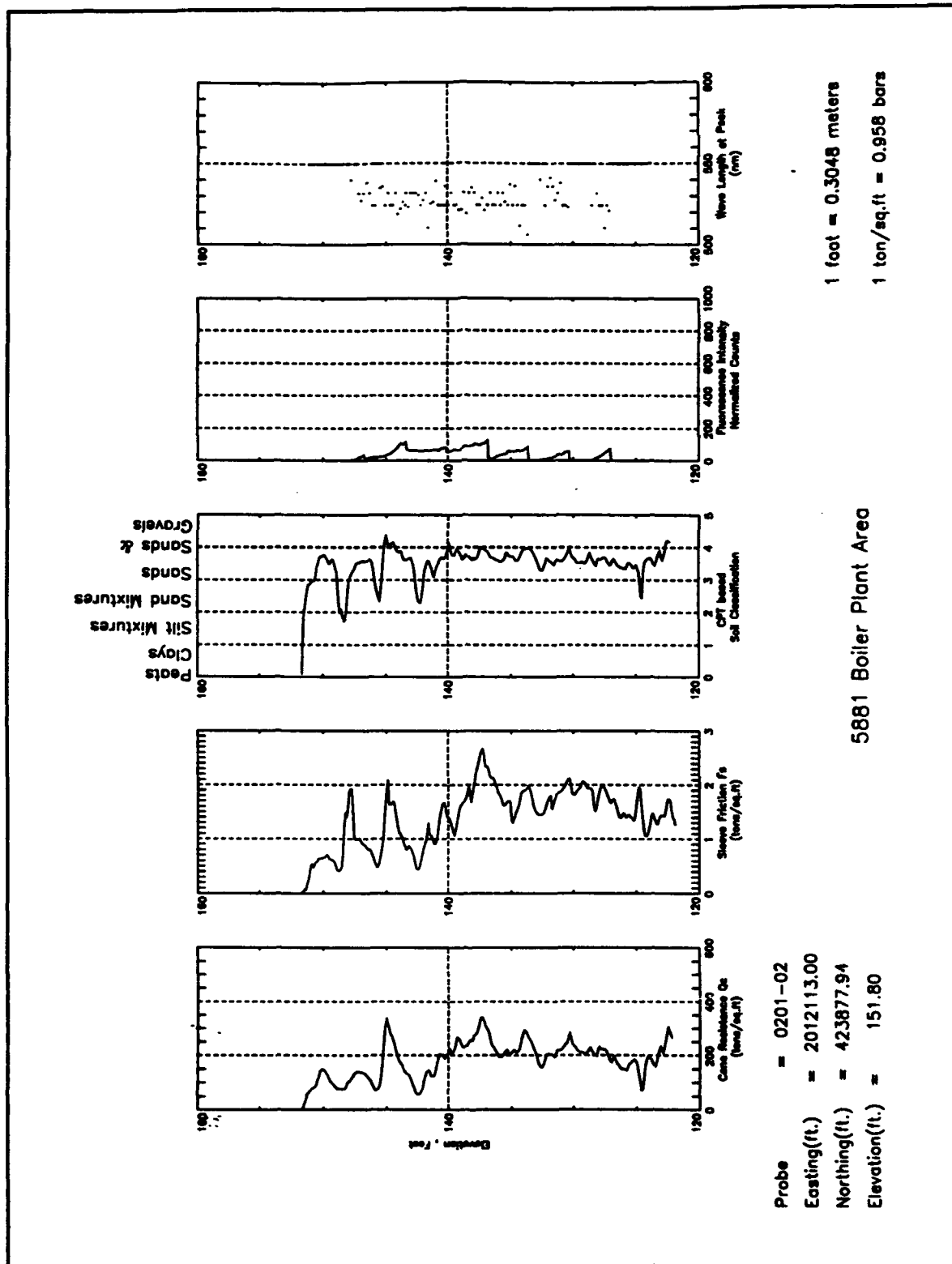

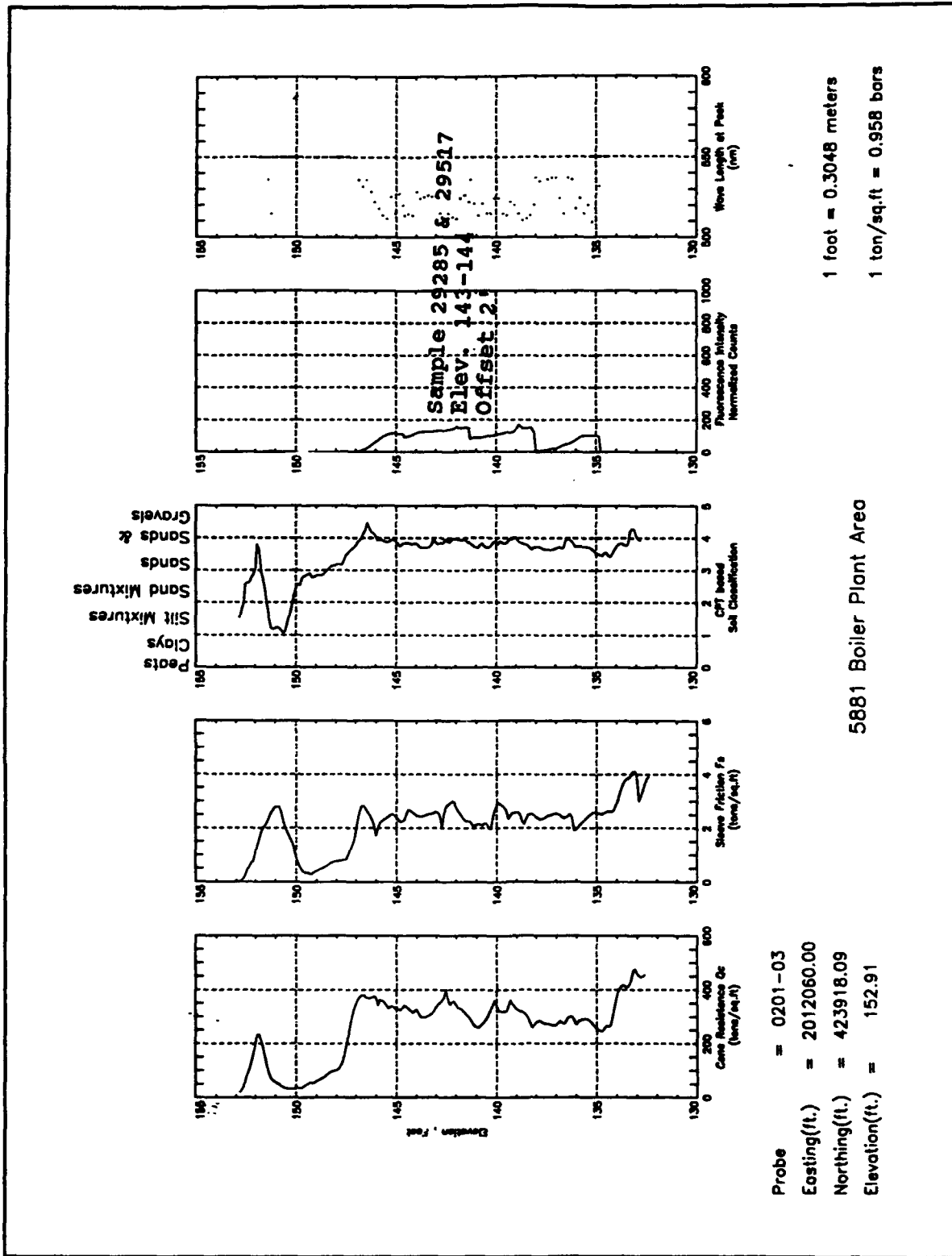

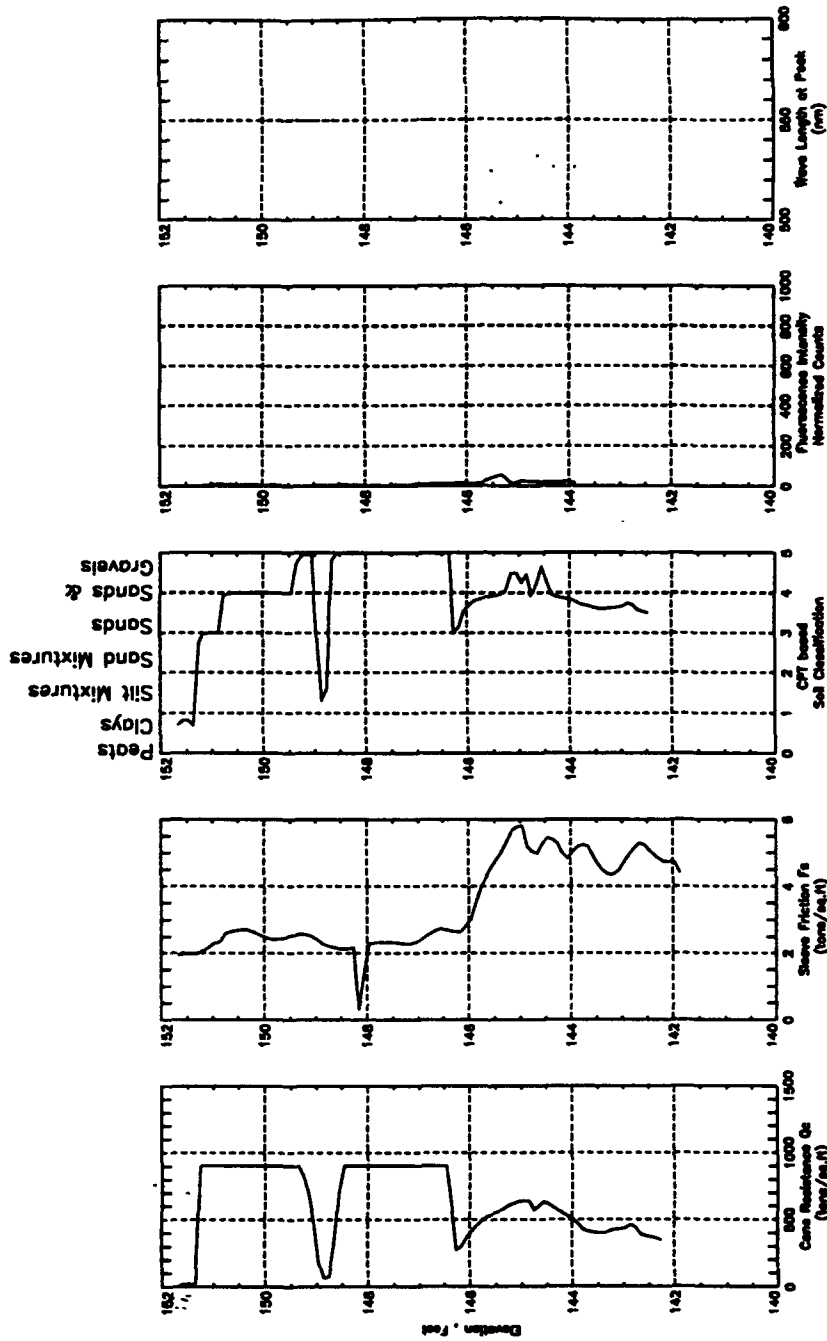

Probe = 0208-01
 Easting(ft.) = 2012186.63
 Northing(ft.) = 423963.22
 Elevation(ft.) = 151.76

1 foot = 0.3048 meters
 1 ton/sq.ft = 0.958 bars

5881 Boiler Plant Area

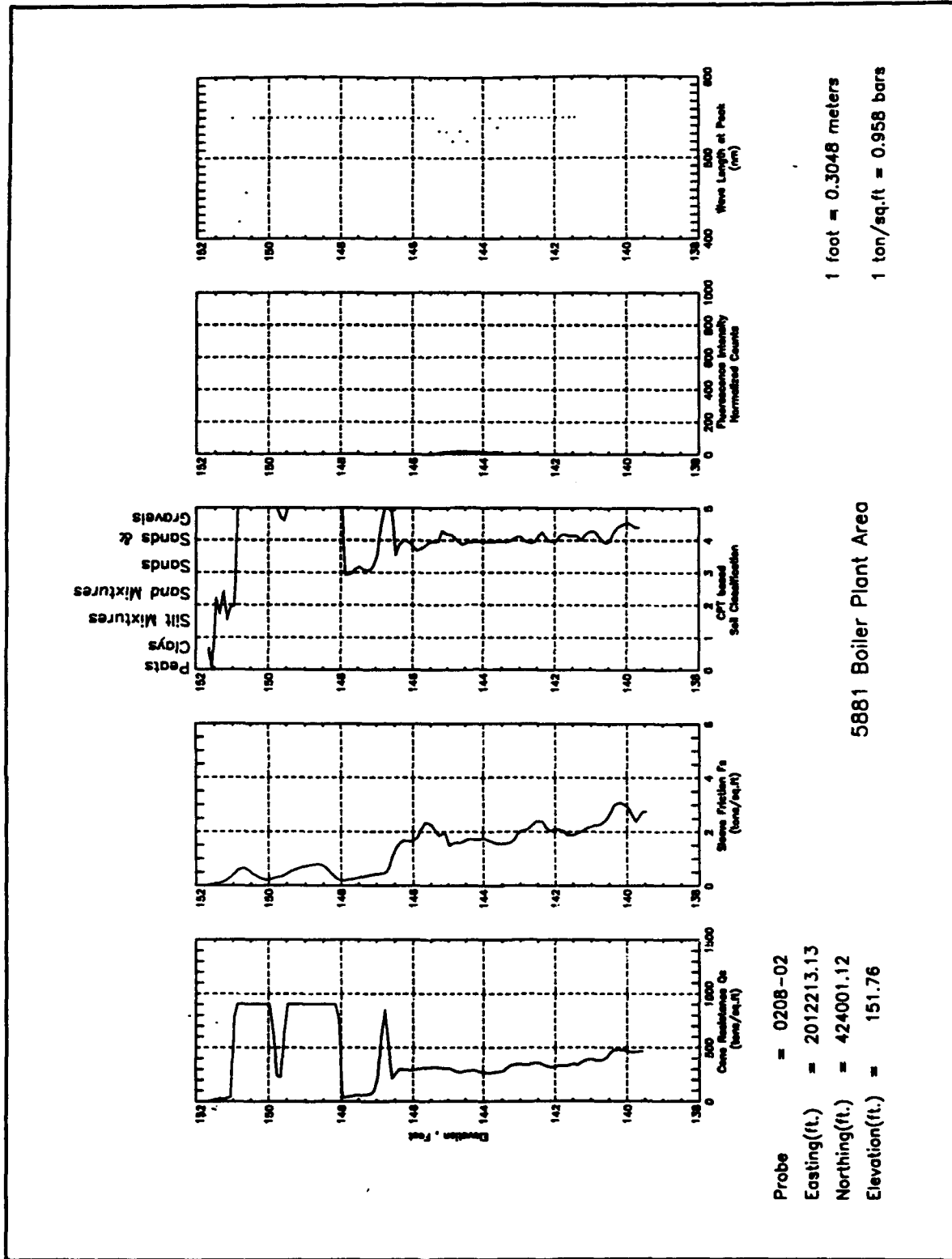

Appendix K

5900 Area Motor Pool

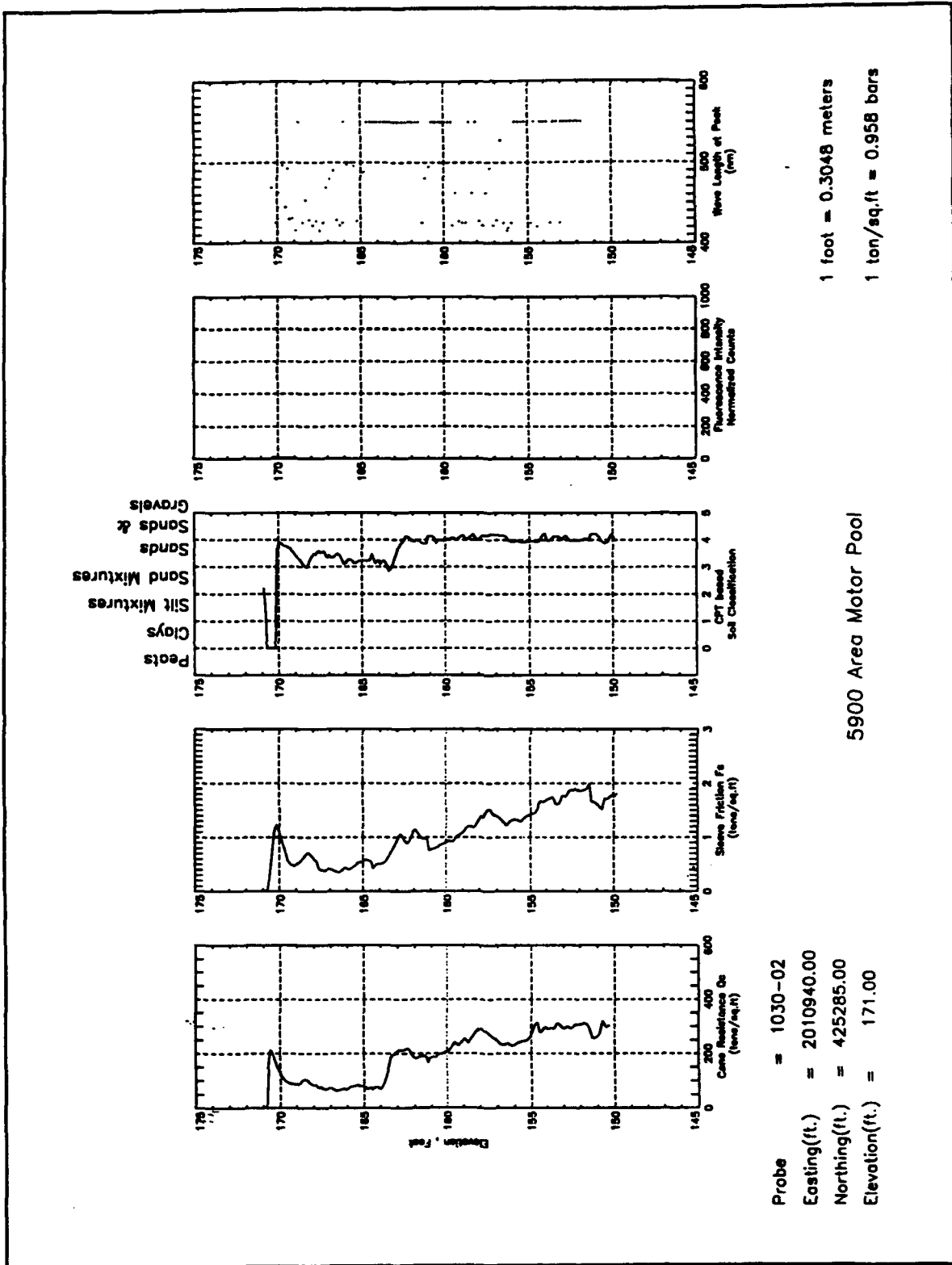

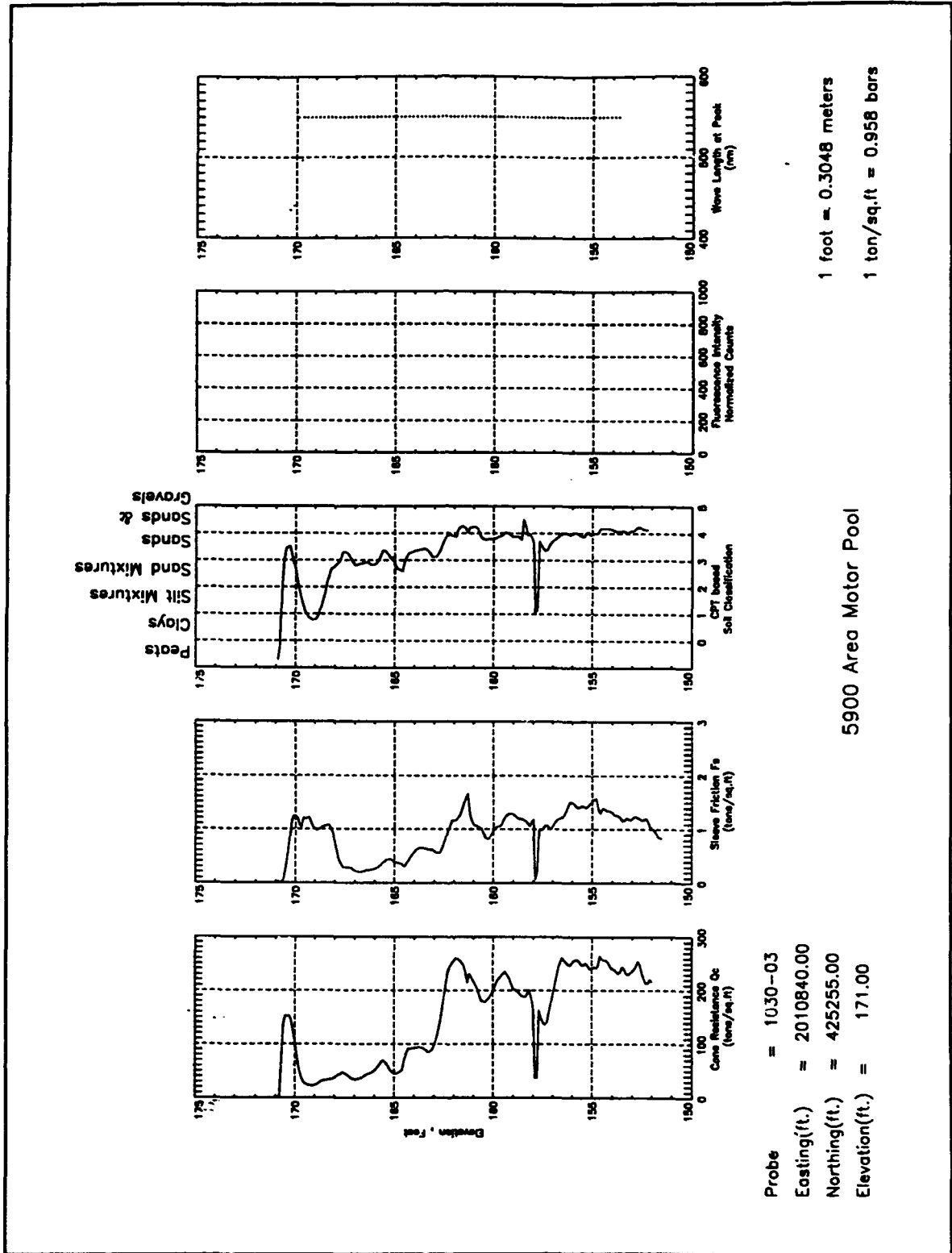

Probe = 1030-03
 Easting(ft.) = 2010840.00
 Northing(ft.) = 425255.00
 Elevation(ft.) = 171.00

1 foot = 0.3048 meters
 1 ton/sq.ft = 0.958 bars

5900 Area Motor Pool

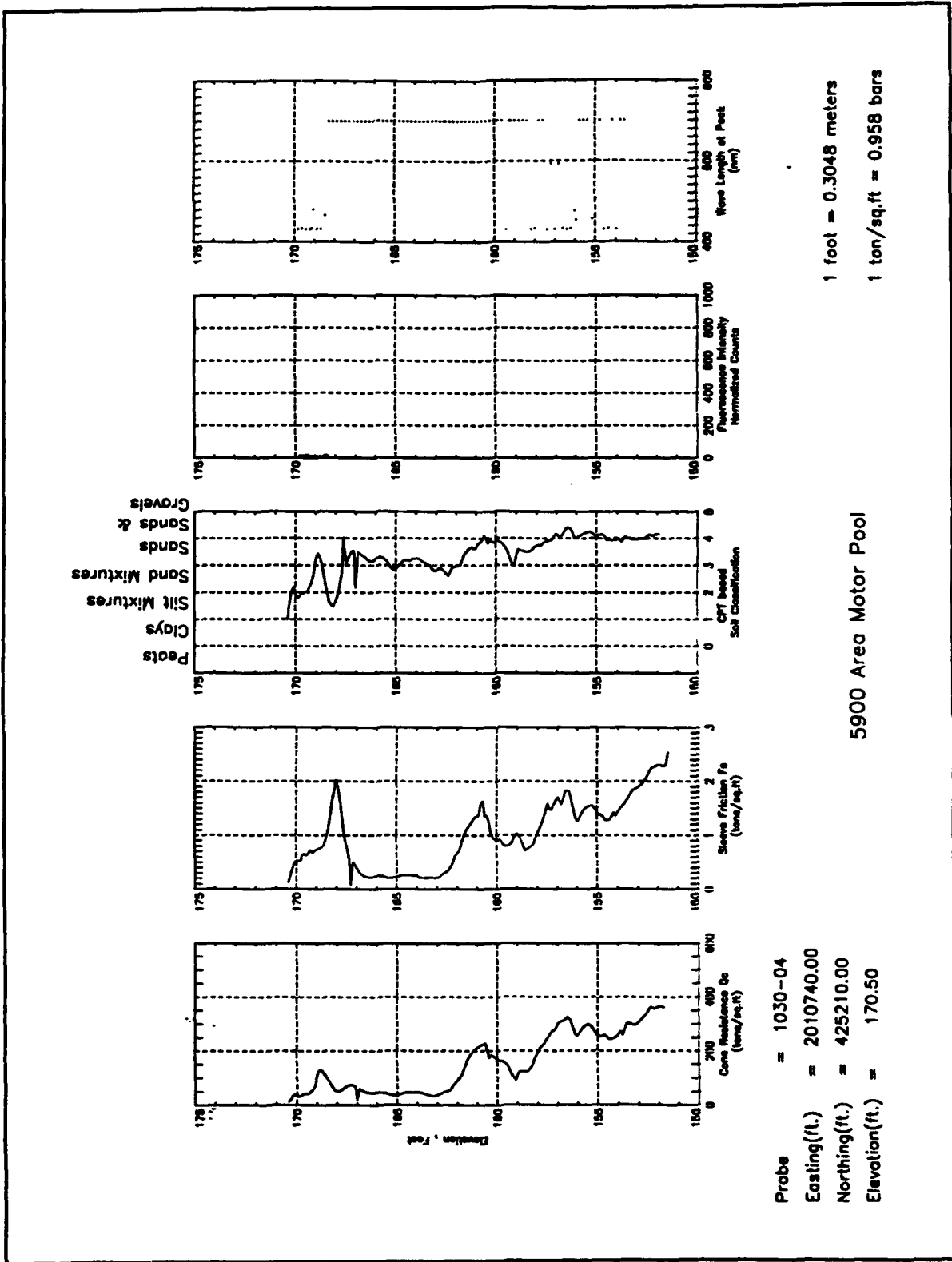

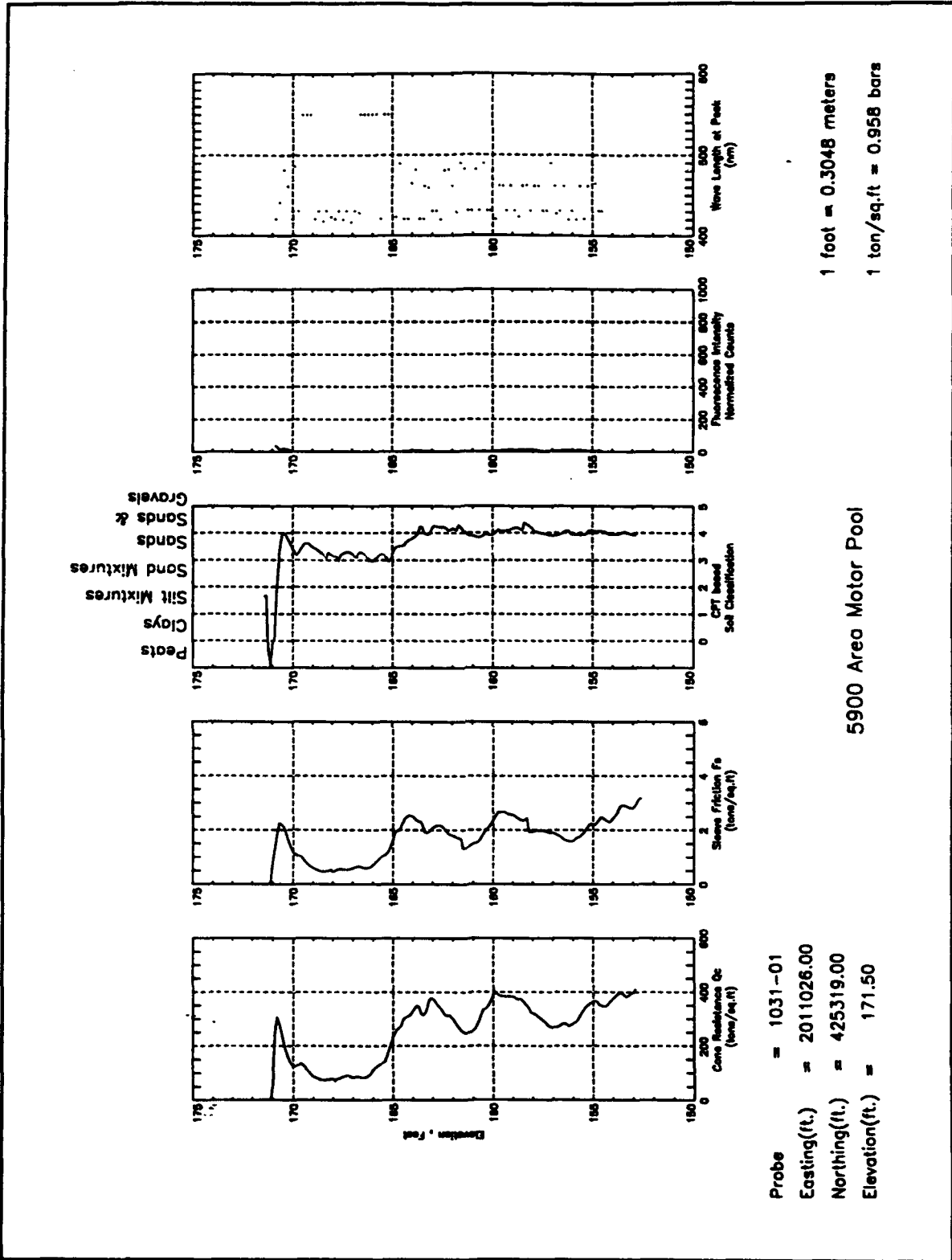

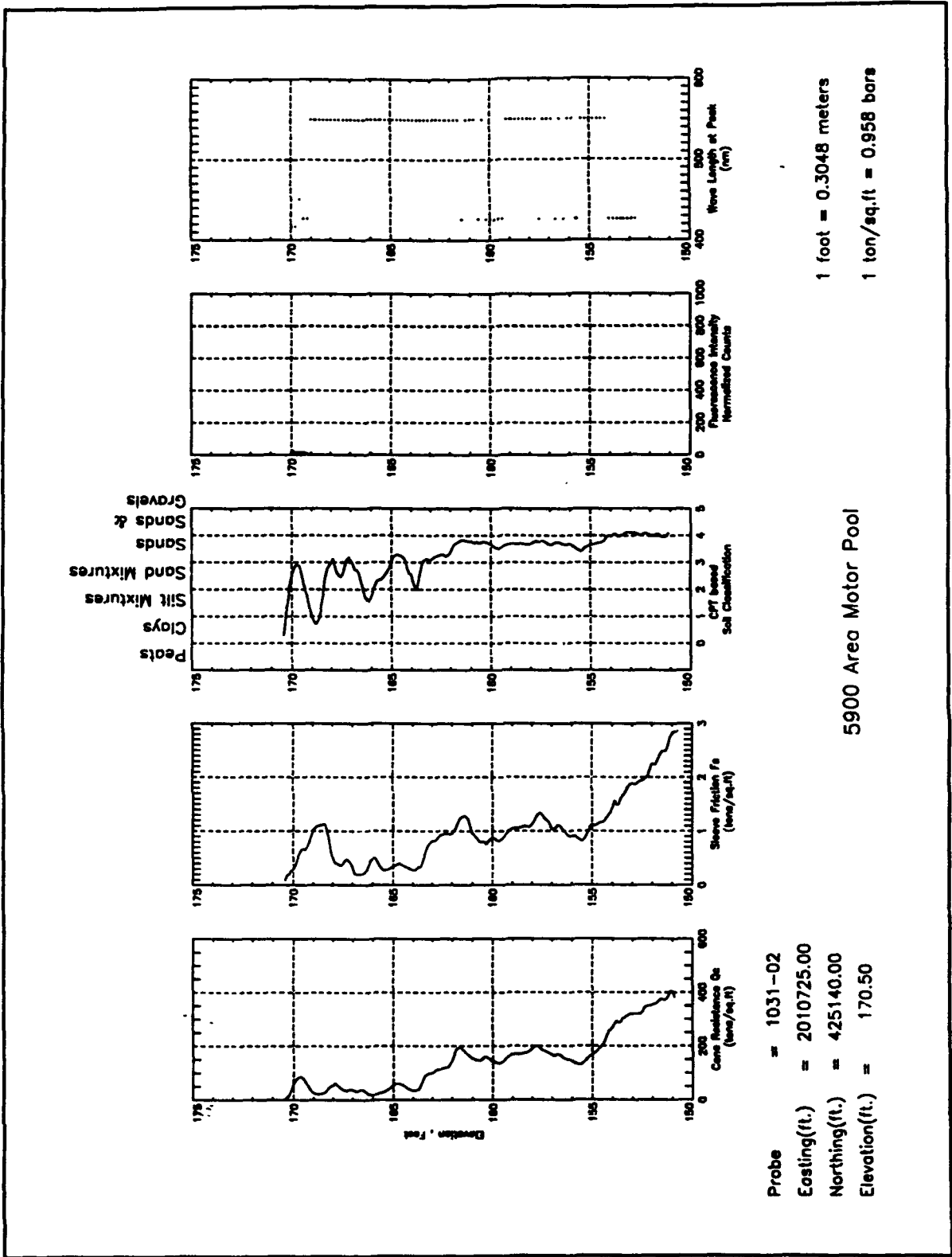

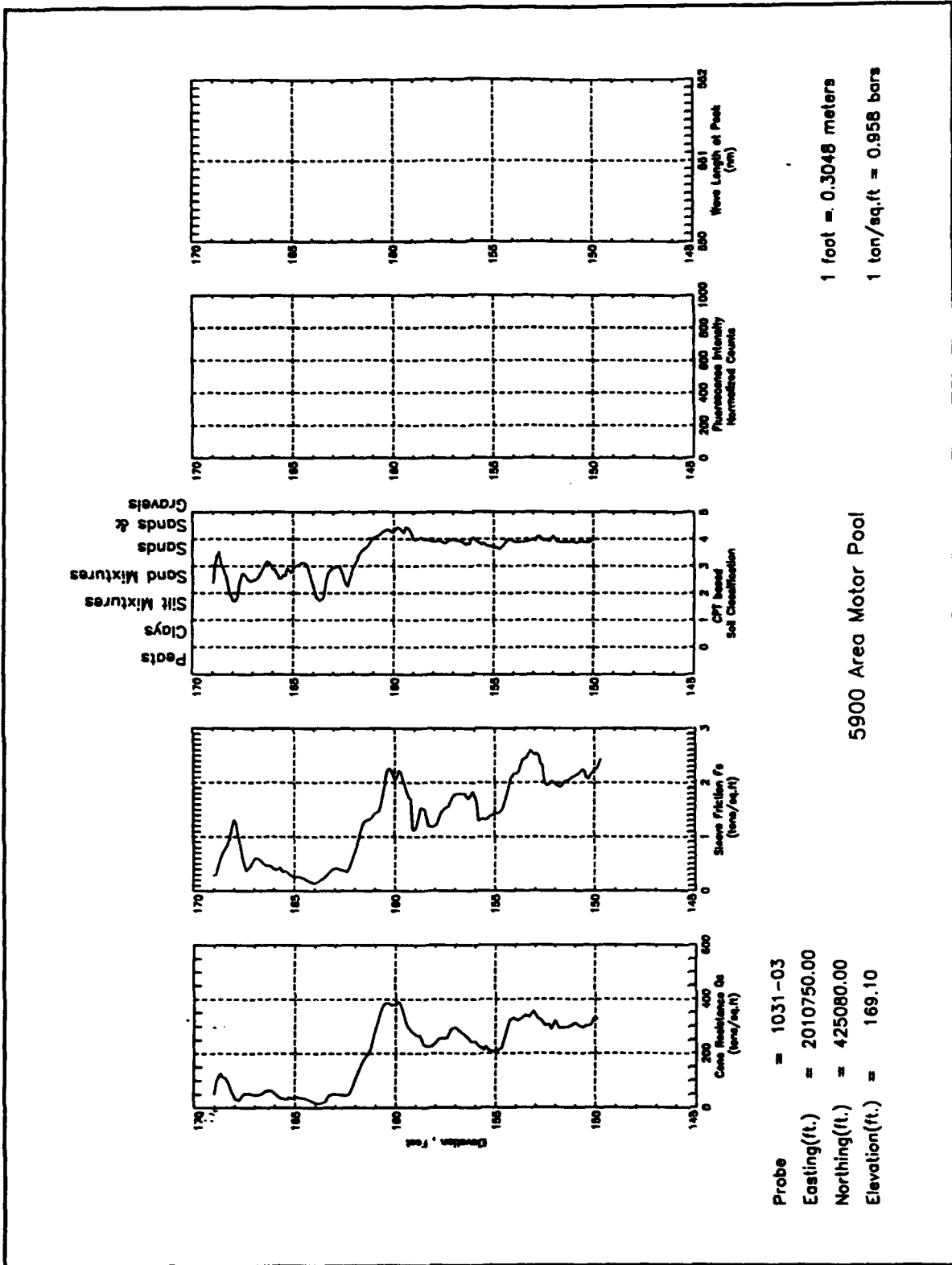

Probe = 1031-03
 Easting(ft.) = 2010750.00
 Northing(ft.) = 425080.00
 Elevation(ft.) = 169.10

5900 Area Motor Pool

1 foot = 0.3048 meters
 1 ton/sq.ft = 0.958 bars

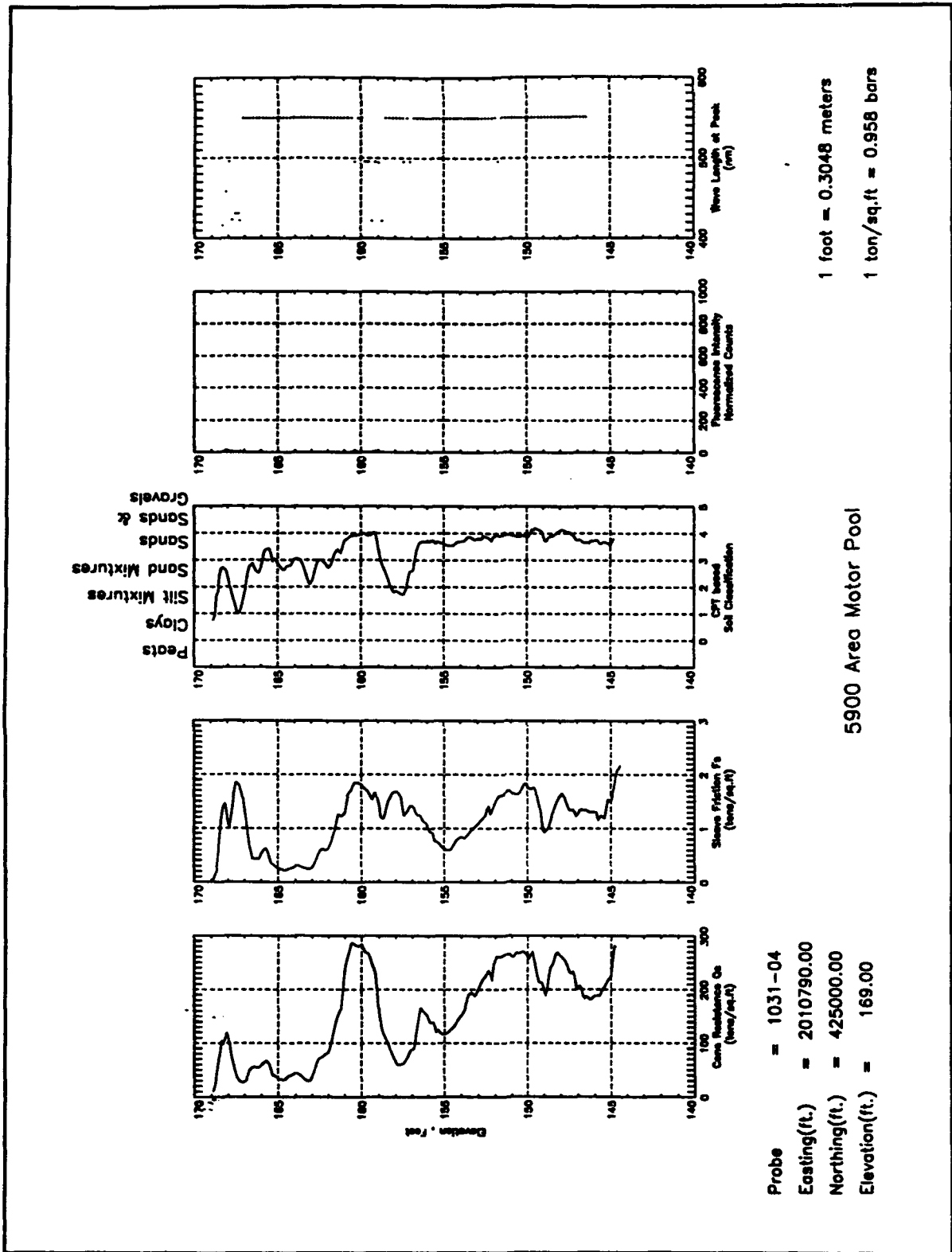

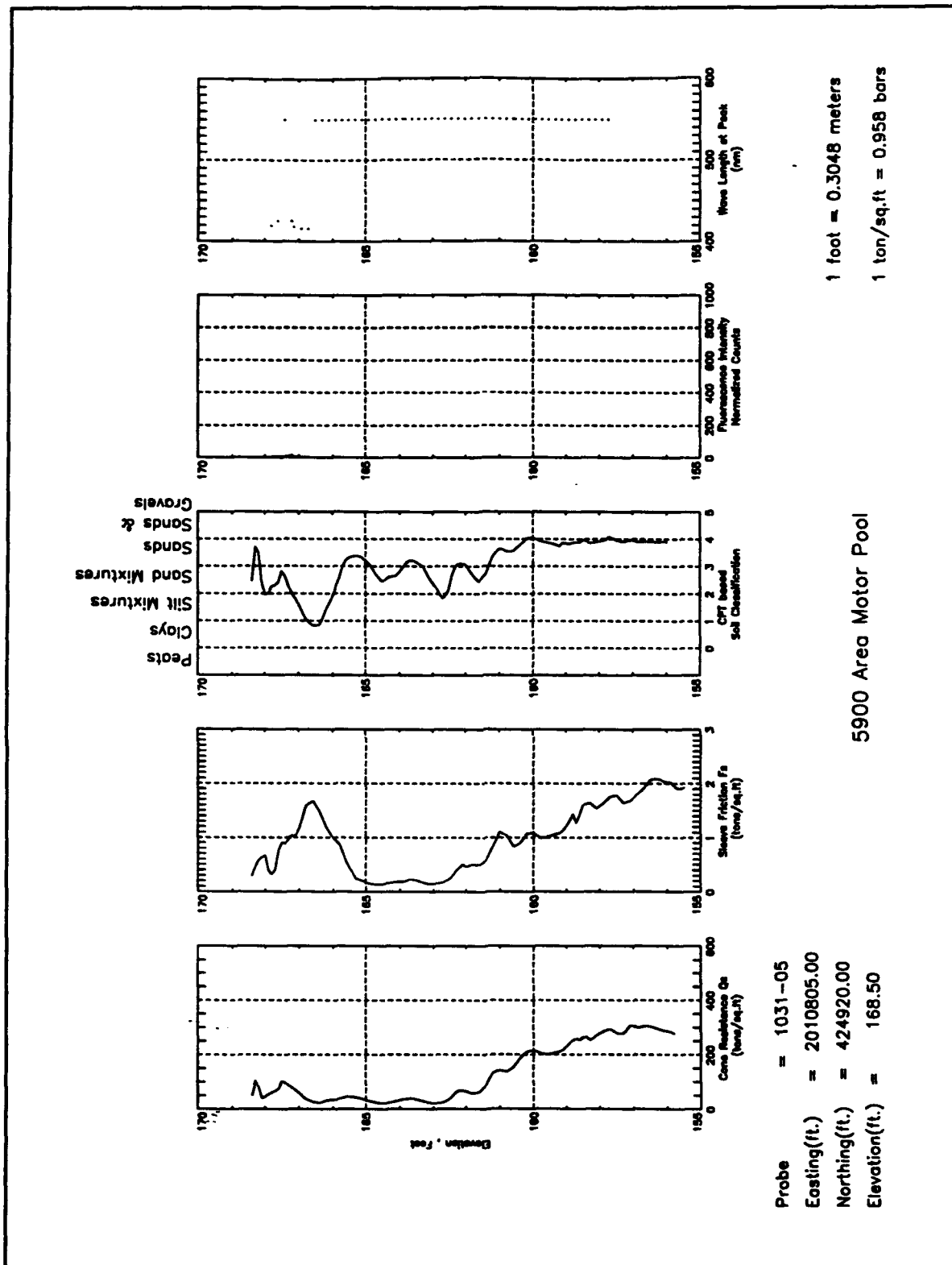

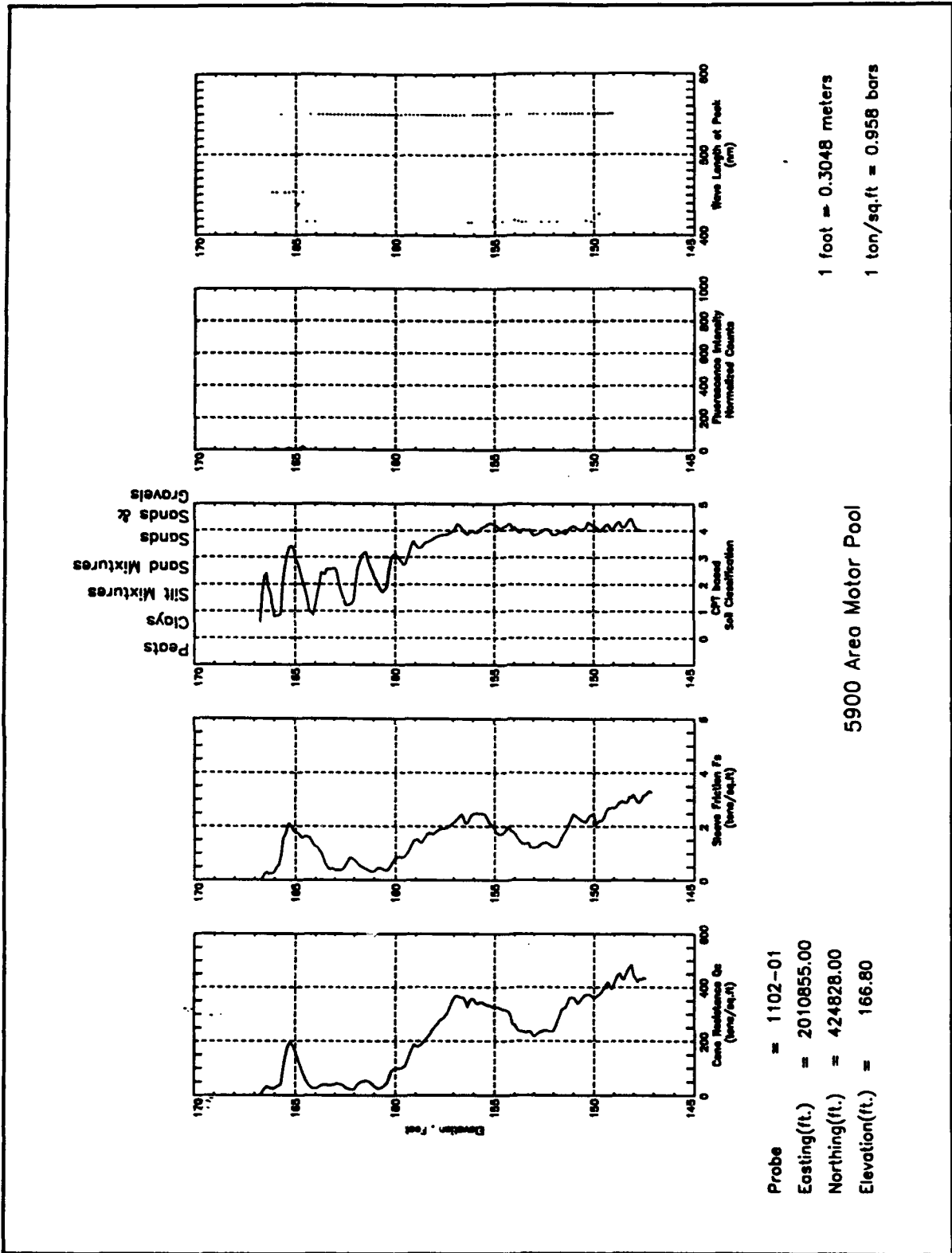

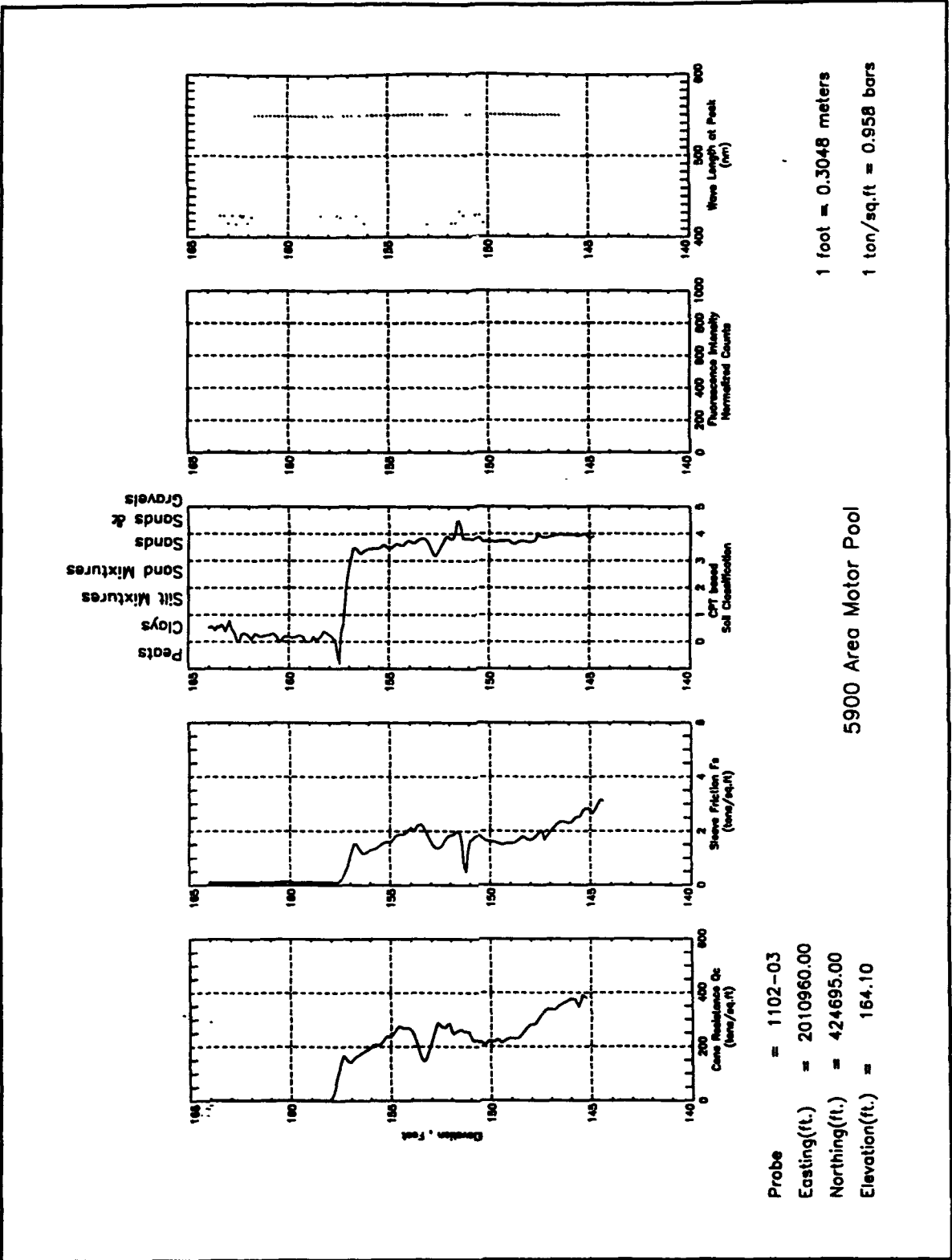

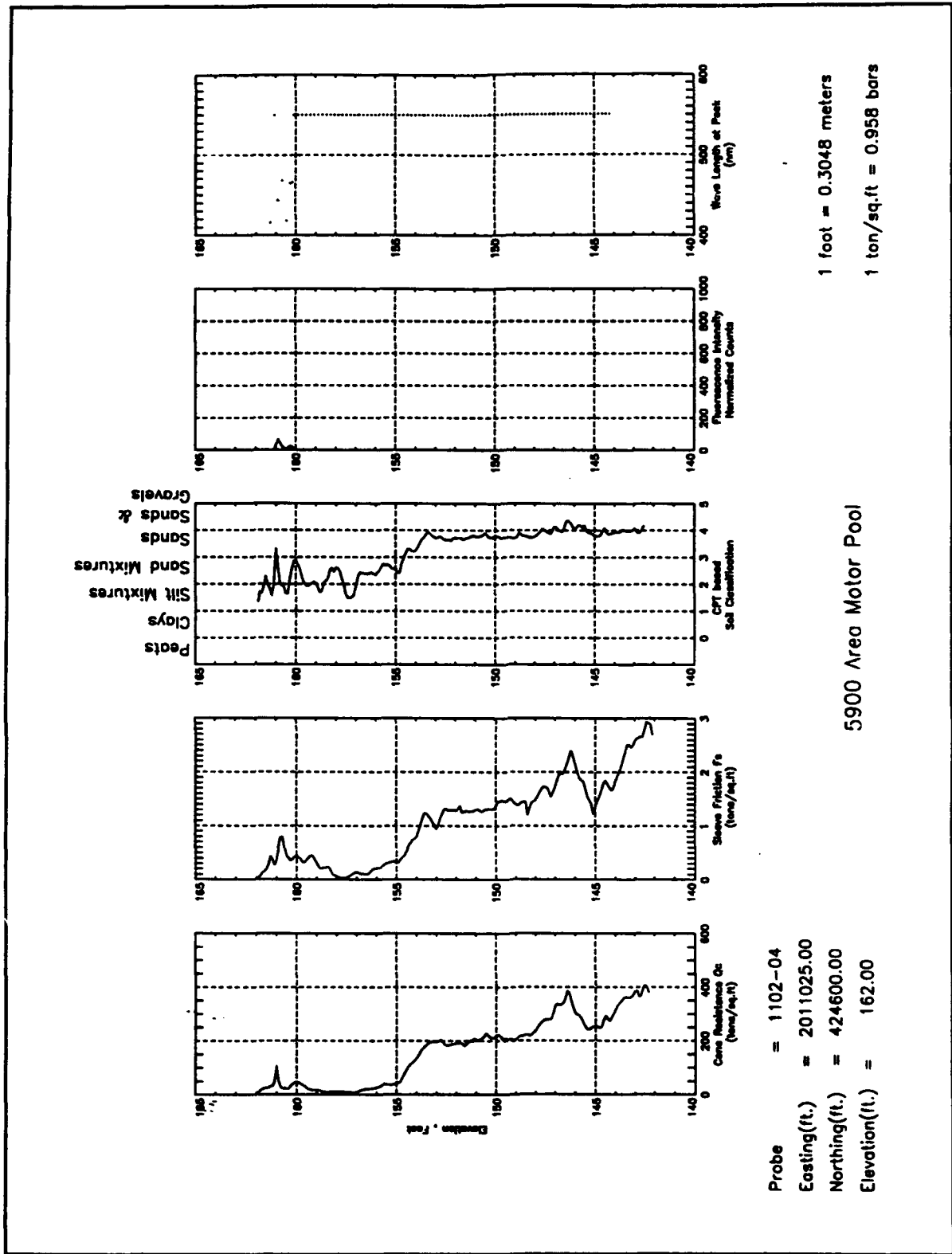

1 foot = 0.3048 meters
 1 ton/sq.ft = 0.958 bars

5900 Area Motor Pool

Probe = 1102-04
 Easting(ft.) = 2011025.00
 Northing(ft.) = 424600.00
 Elevation(ft.) = 162.00

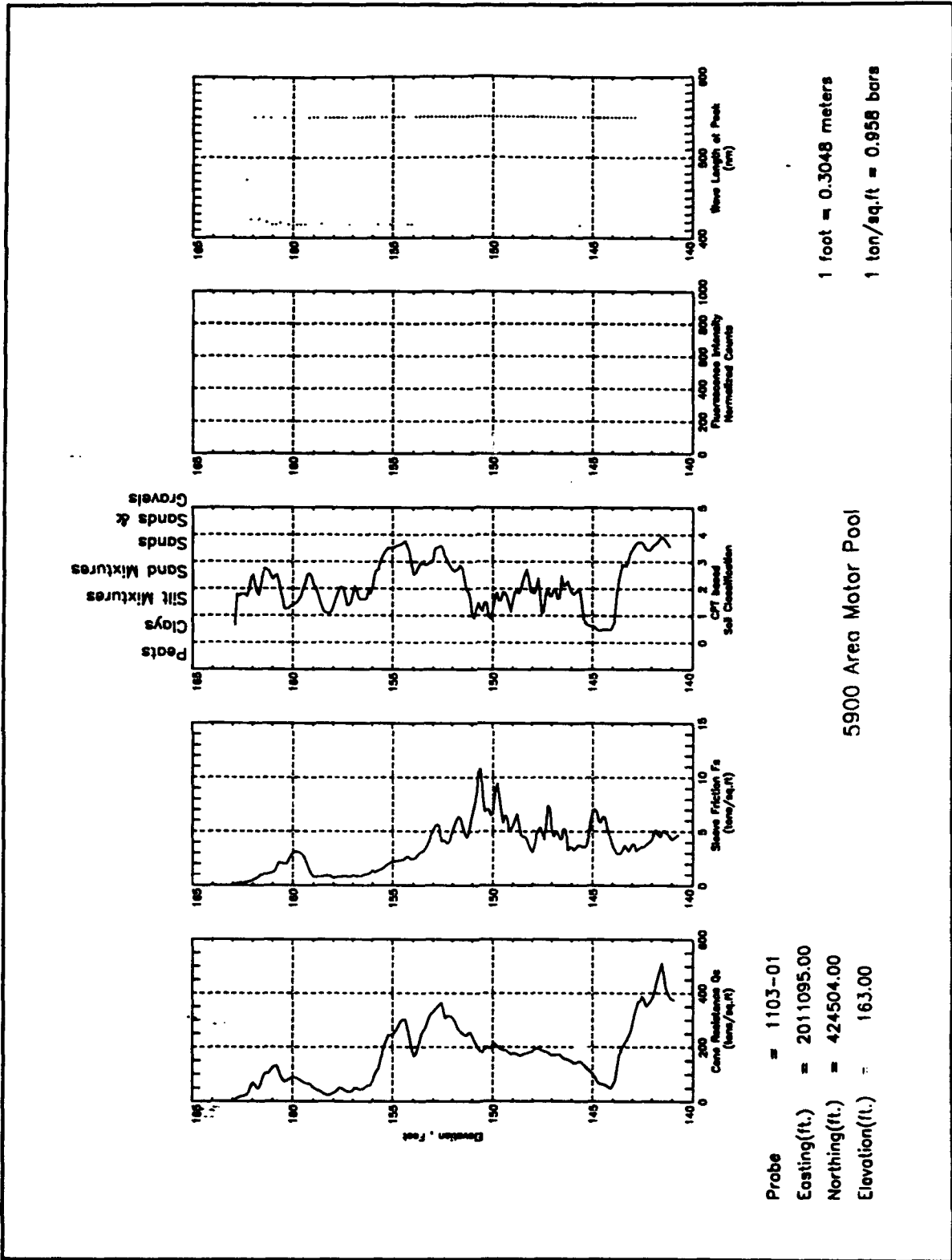

Probe = 1103-01
 Easting(ft.) = 2011095.00
 Northing(ft.) = 424504.00
 Elevation(ft.) = 163.00

1 foot = 0.3048 meters
 1 ton/sq.ft = 0.958 bars

5900 Area Motor Pool

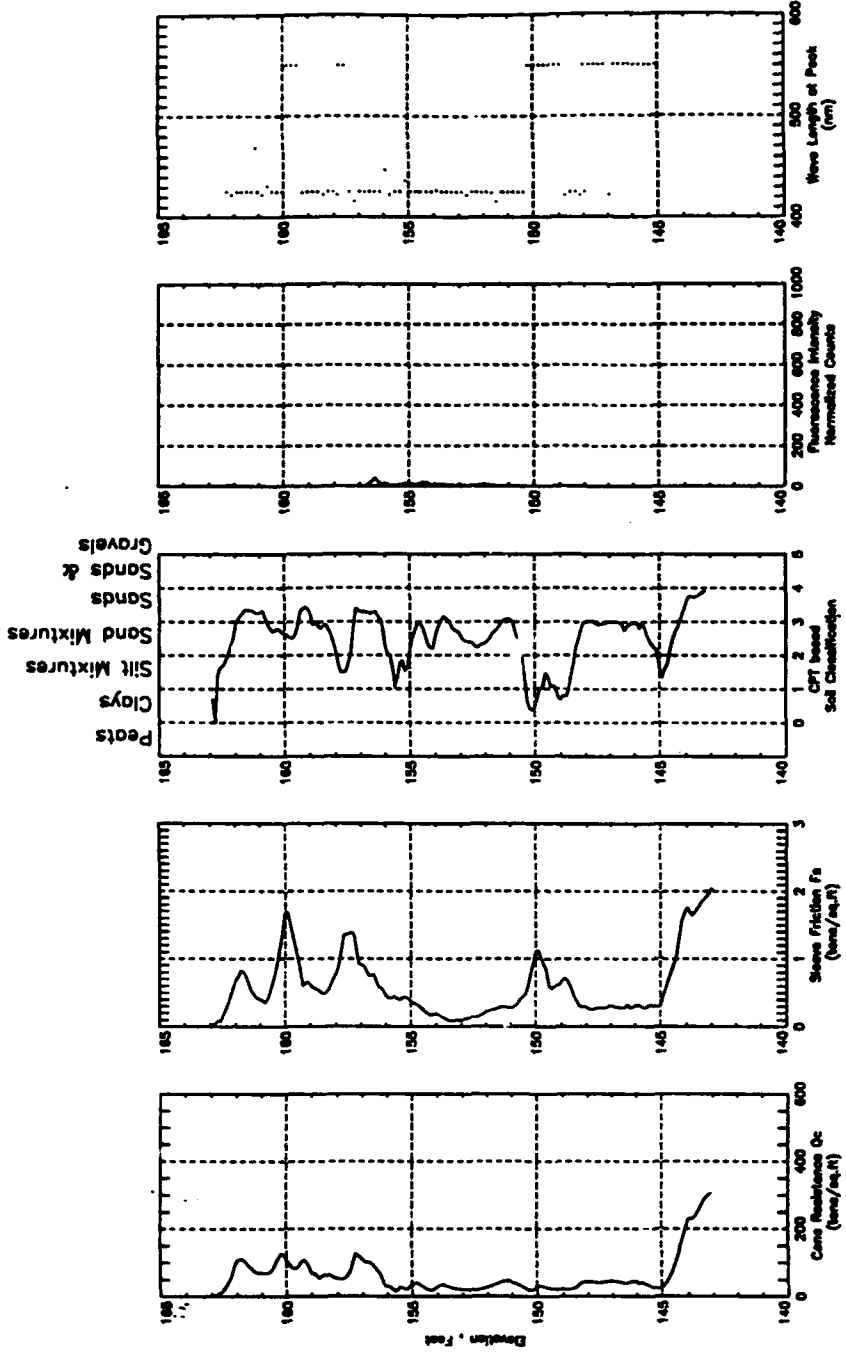

1 foot = 0.3048 meters
 1 ton/sq.ft = 0.958 bars

5900 Area Motor Pool

Probe = 1103-02
 Easting(ft.) = 2011164.00
 Northing(ft.) = 424420.00
 Elevation(ft.) = 163.00

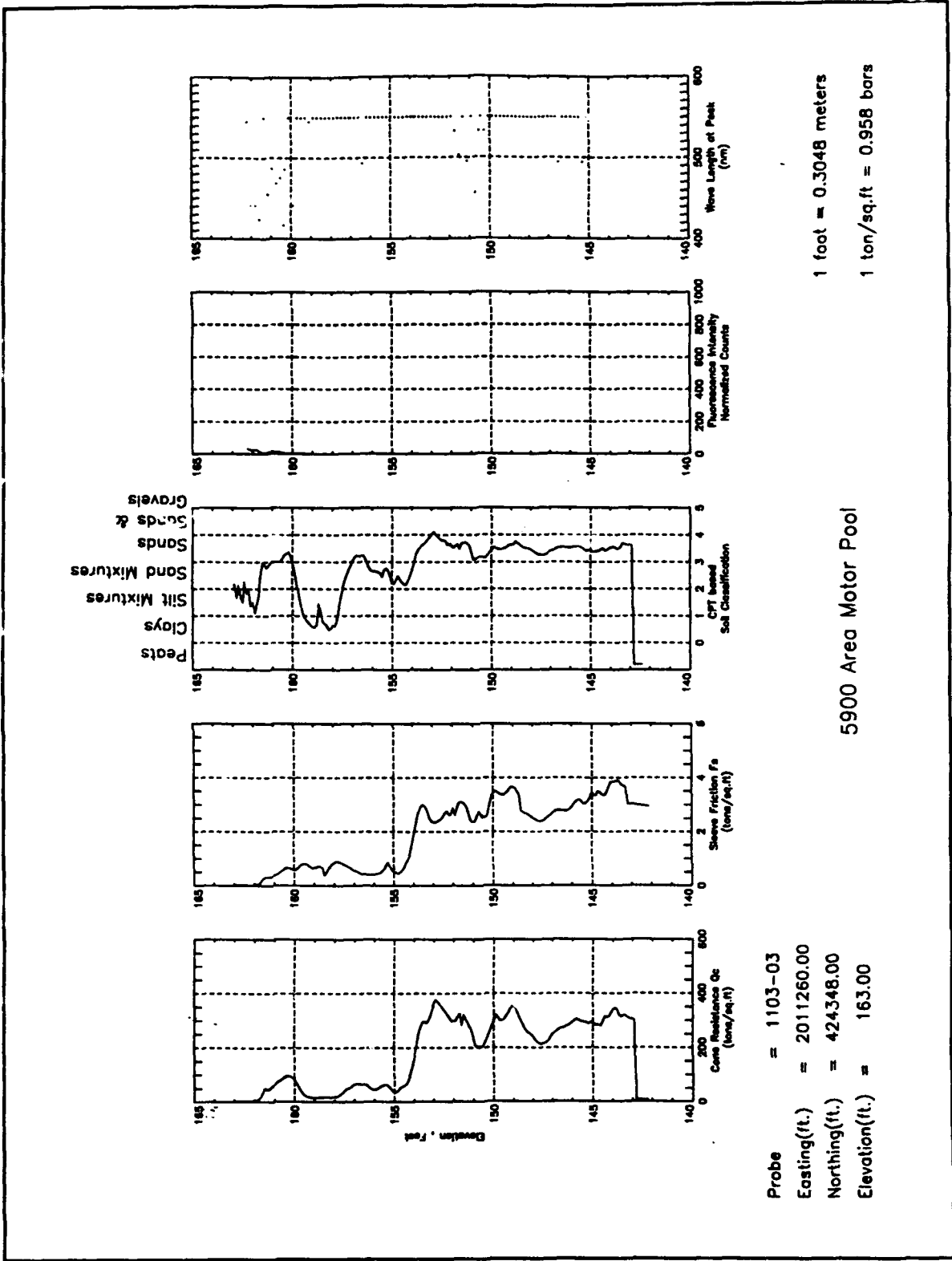

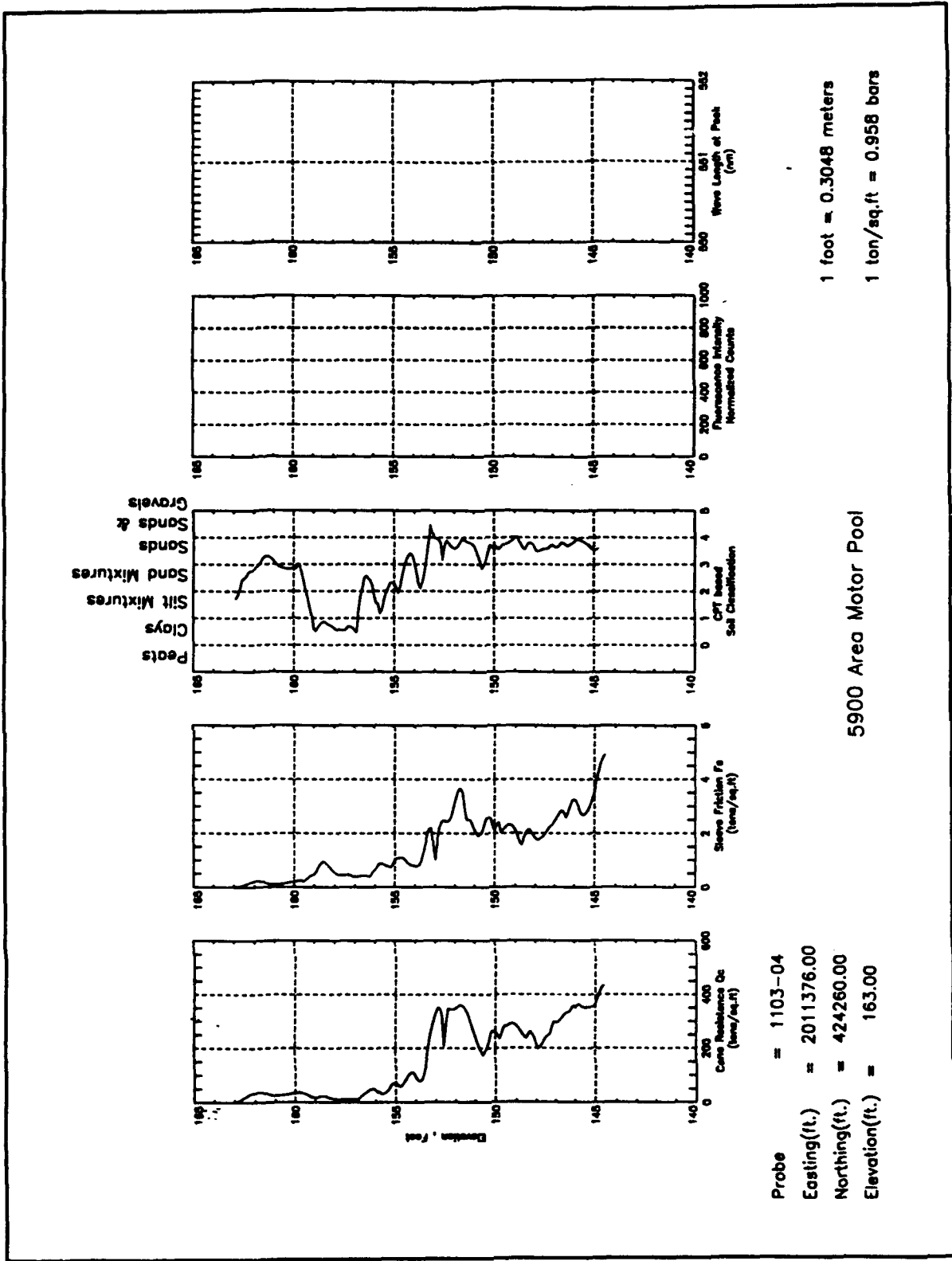

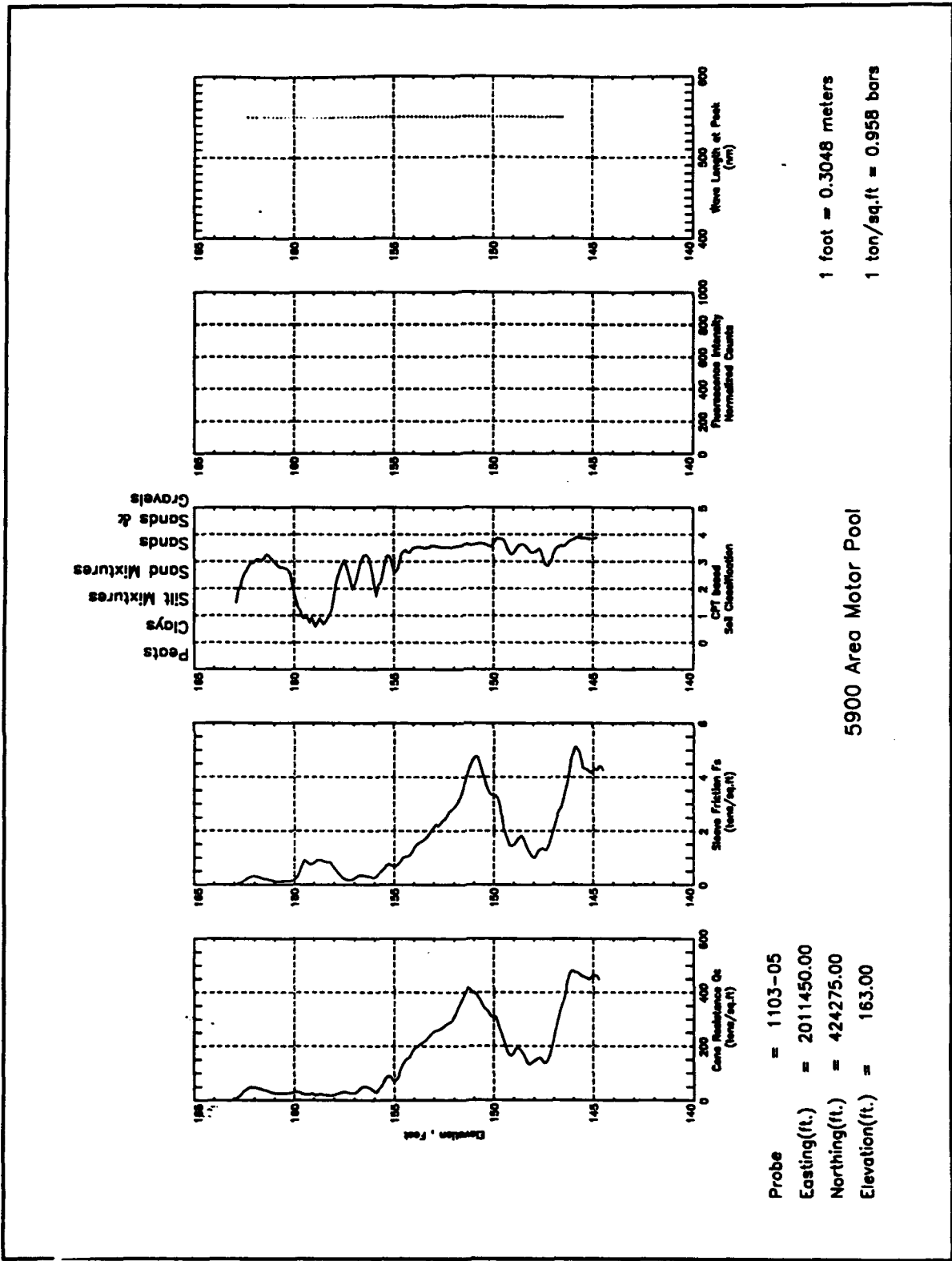

Probe = 1103-05
 Easting(ft.) = 2011450.00
 Northing(ft.) = 424275.00
 Elevation(ft.) = 163.00

5900 Area Motor Pool
 1 foot = 0.3048 meters
 1 ton/sq.ft = 0.958 bars

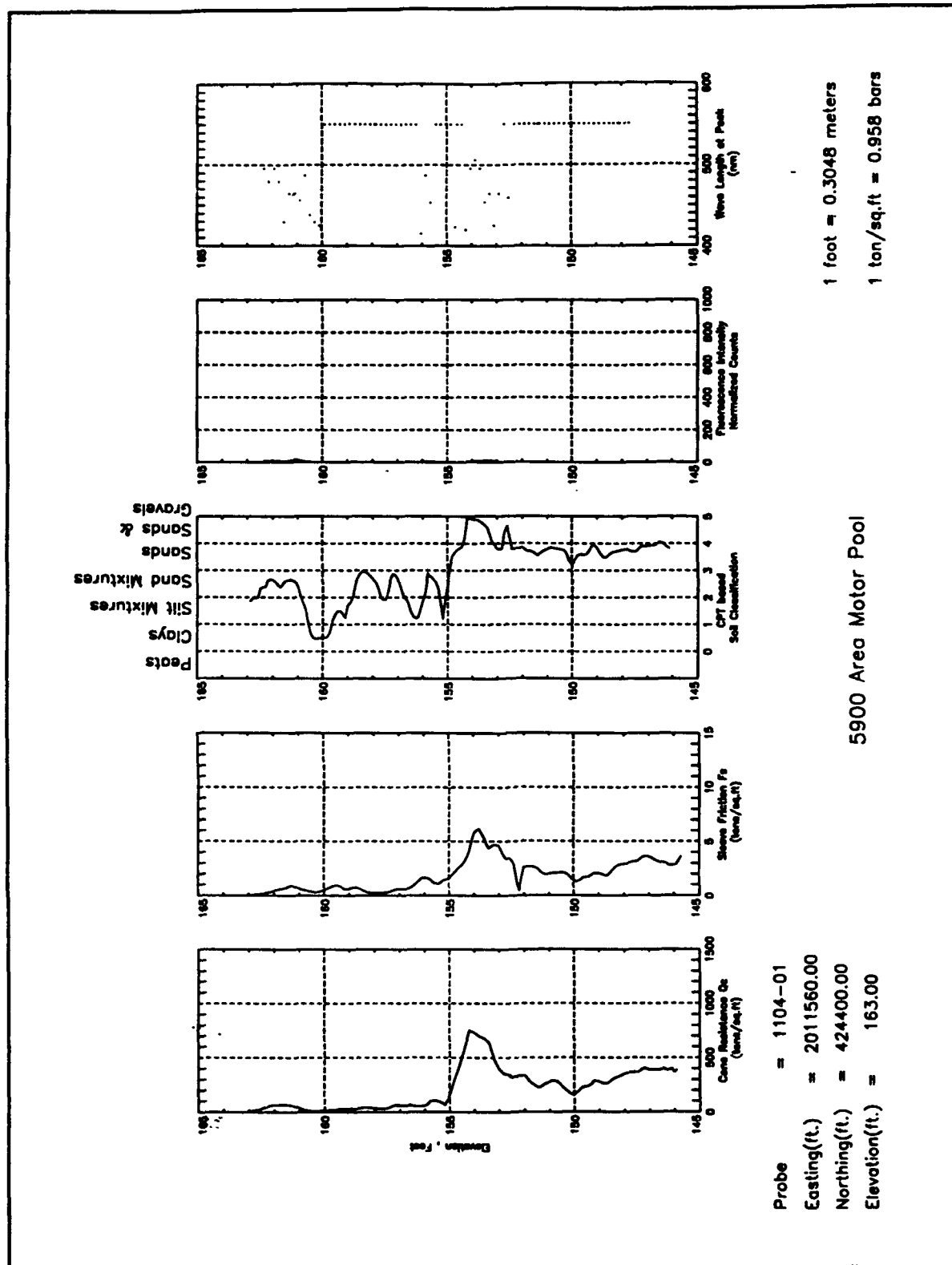

Appendix L

8100 Area Motor Pool

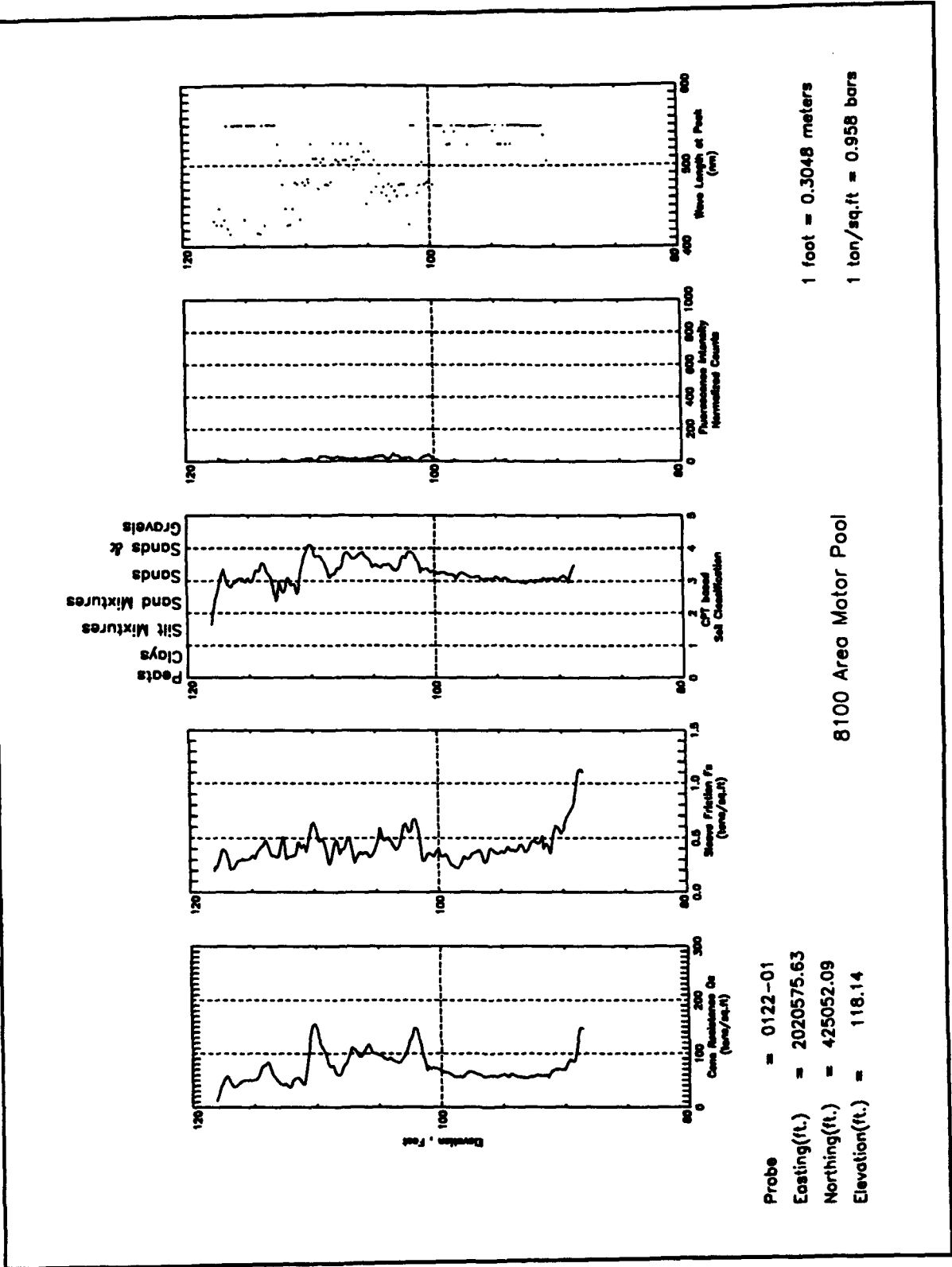

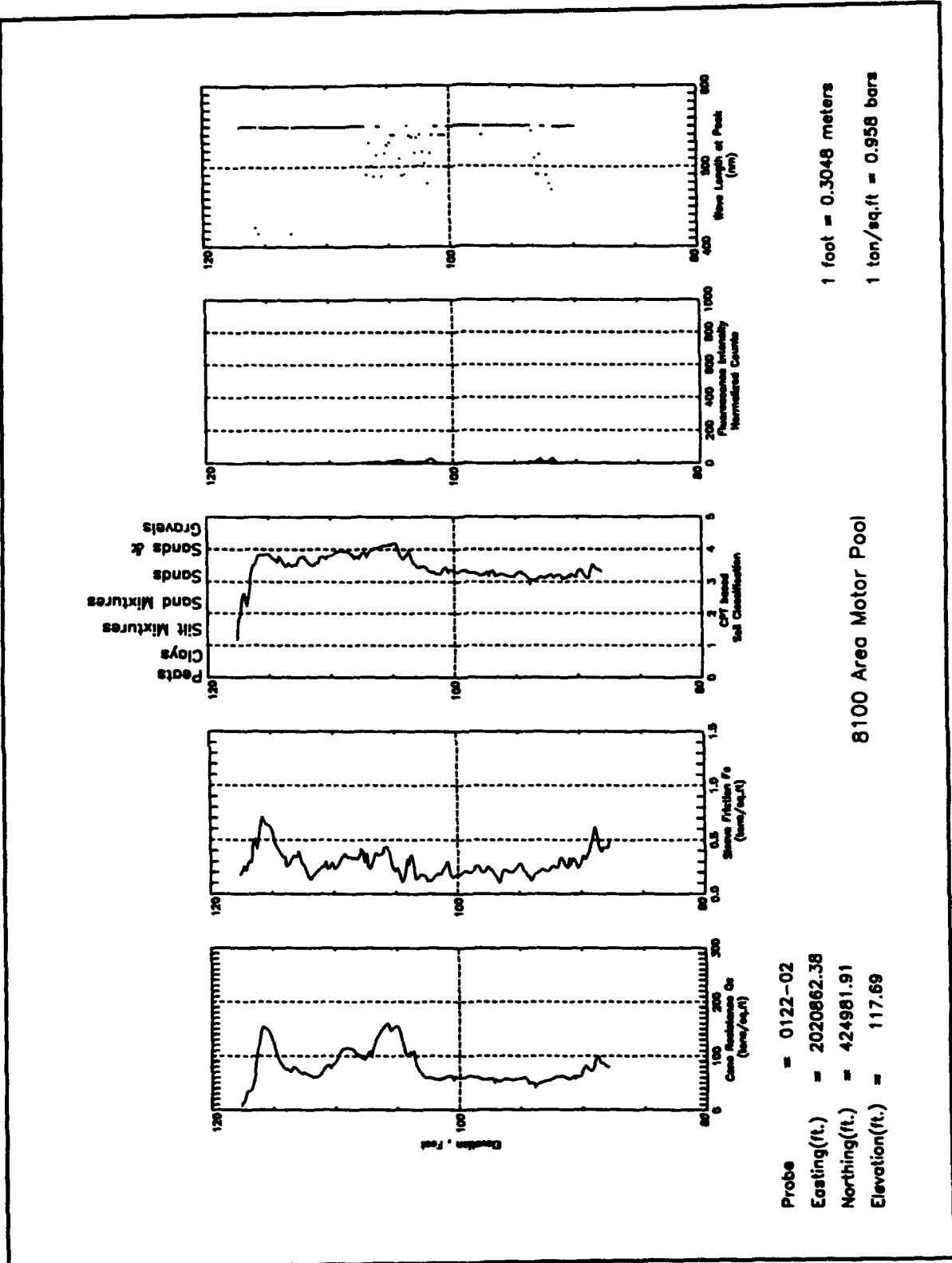

Probe = 0122-02
 Easting(ft.) = 2020862.38
 Northing(ft.) = 424981.91
 Elevation(ft.) = 117.69

1 foot = 0.3048 meters
 1 ton/sq.ft = 0.958 bars

8100 Area Motor Pool

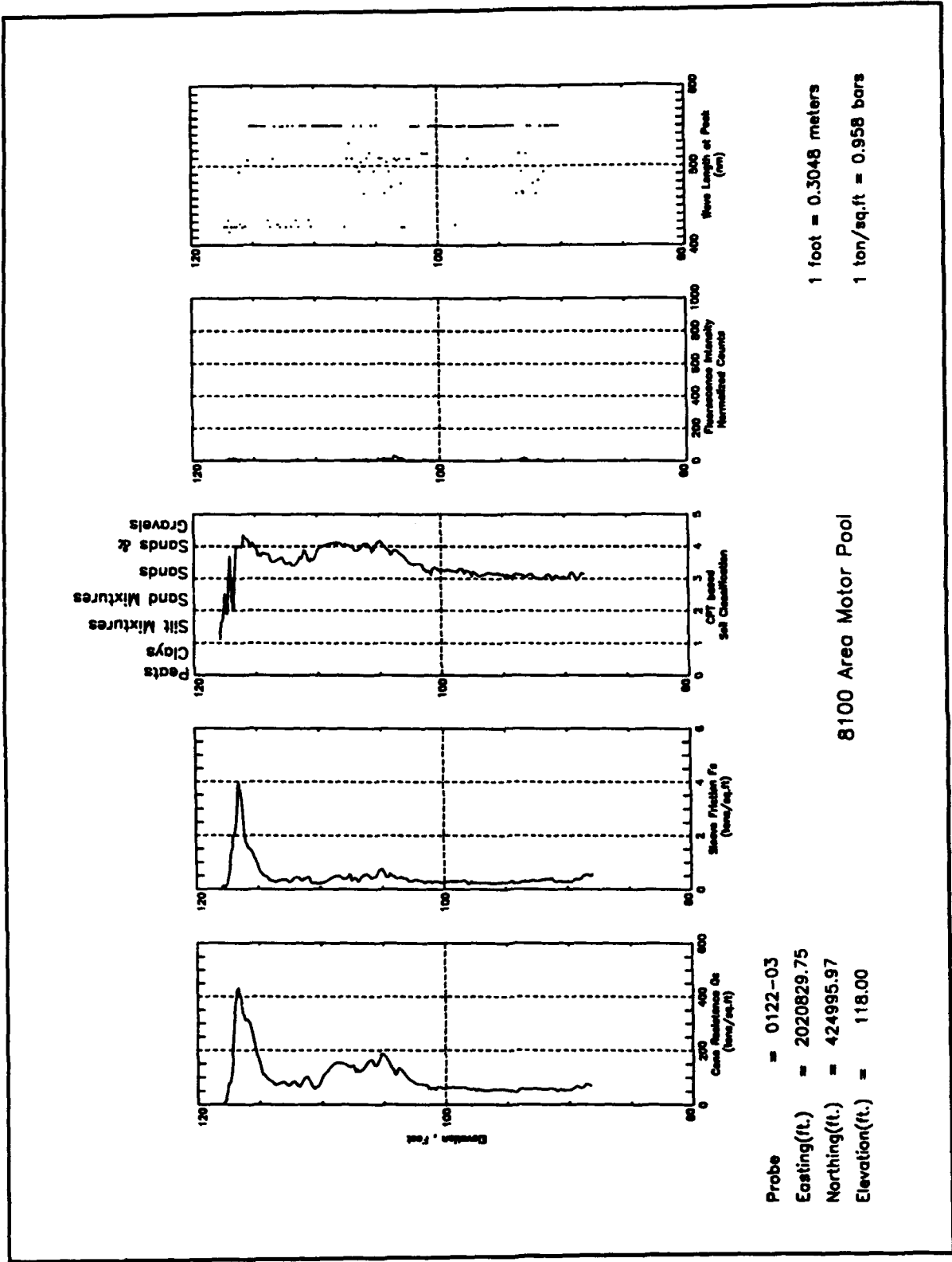

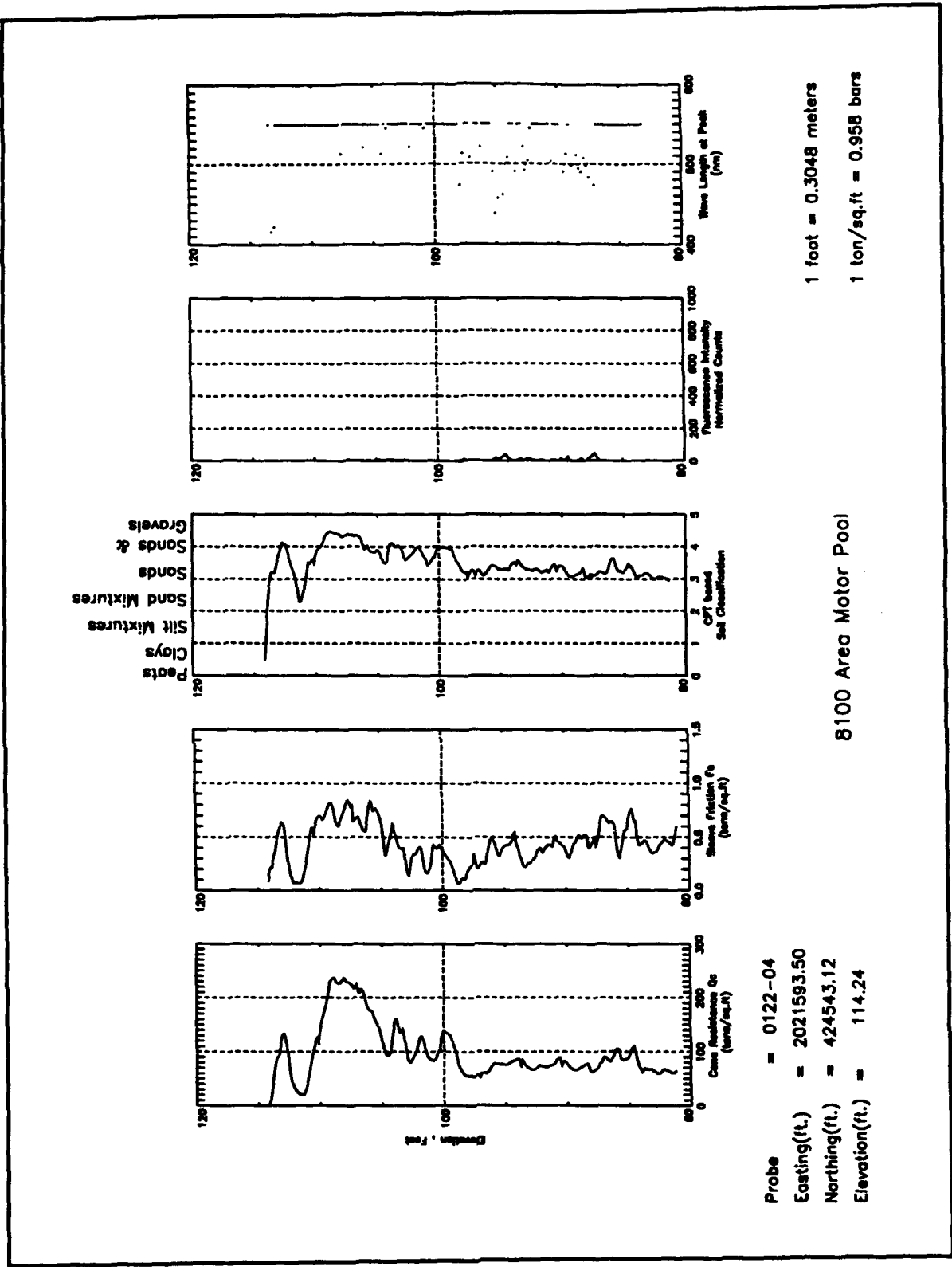

Probe = 0122-04
 Easting(ft.) = 2021593.50
 Northing(ft.) = 424543.12
 Elevation(ft.) = 114.24

8100 Area Motor Pool

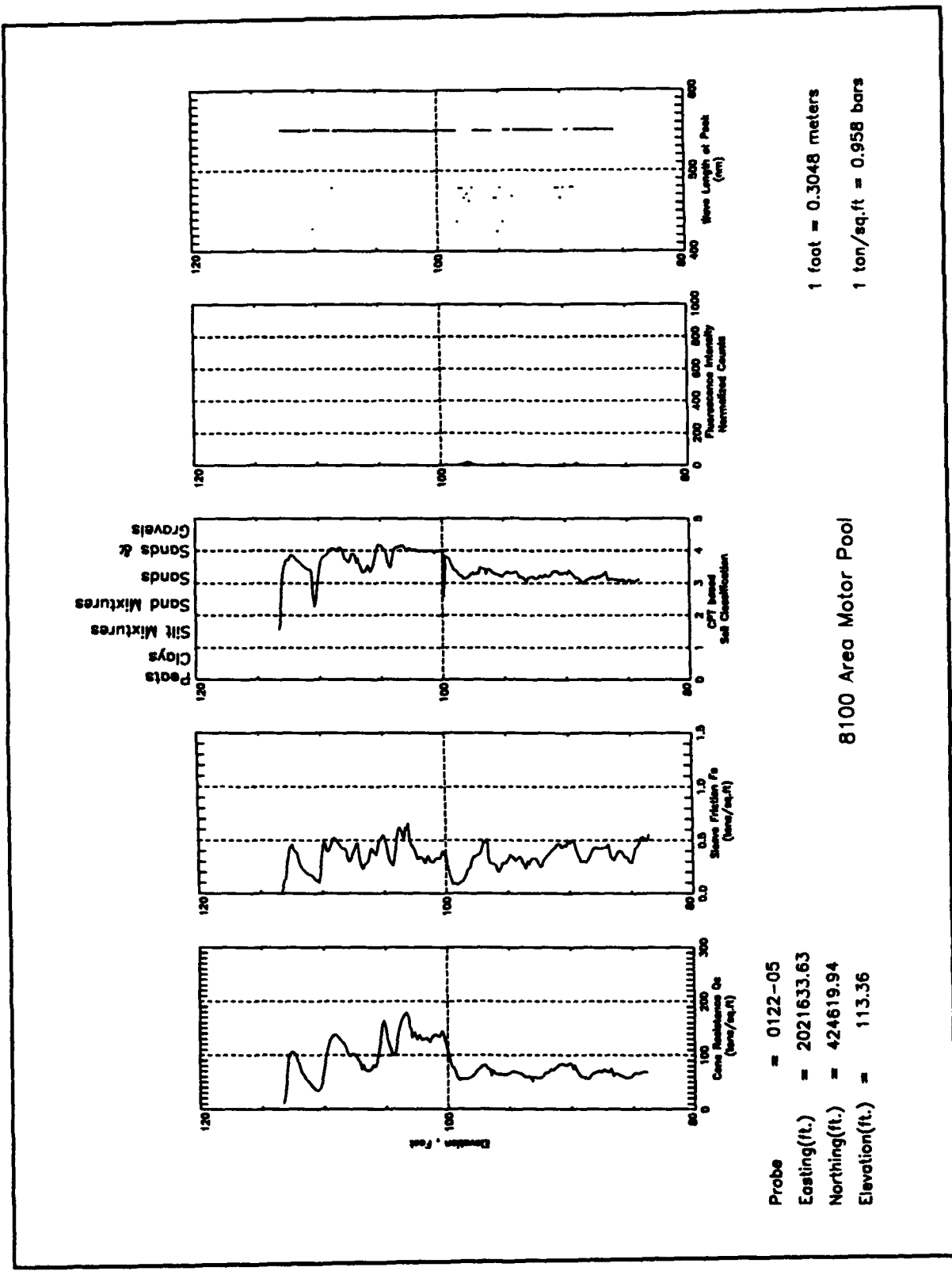

Probe = 0122-05
 Easting(ft.) = 2021633.63
 Northing(ft.) = 424619.94
 Elevation(ft.) = 113.36

8100 Area Motor Pool

1 foot = 0.3048 meters
 1 ton/sq.ft = 0.958 bars

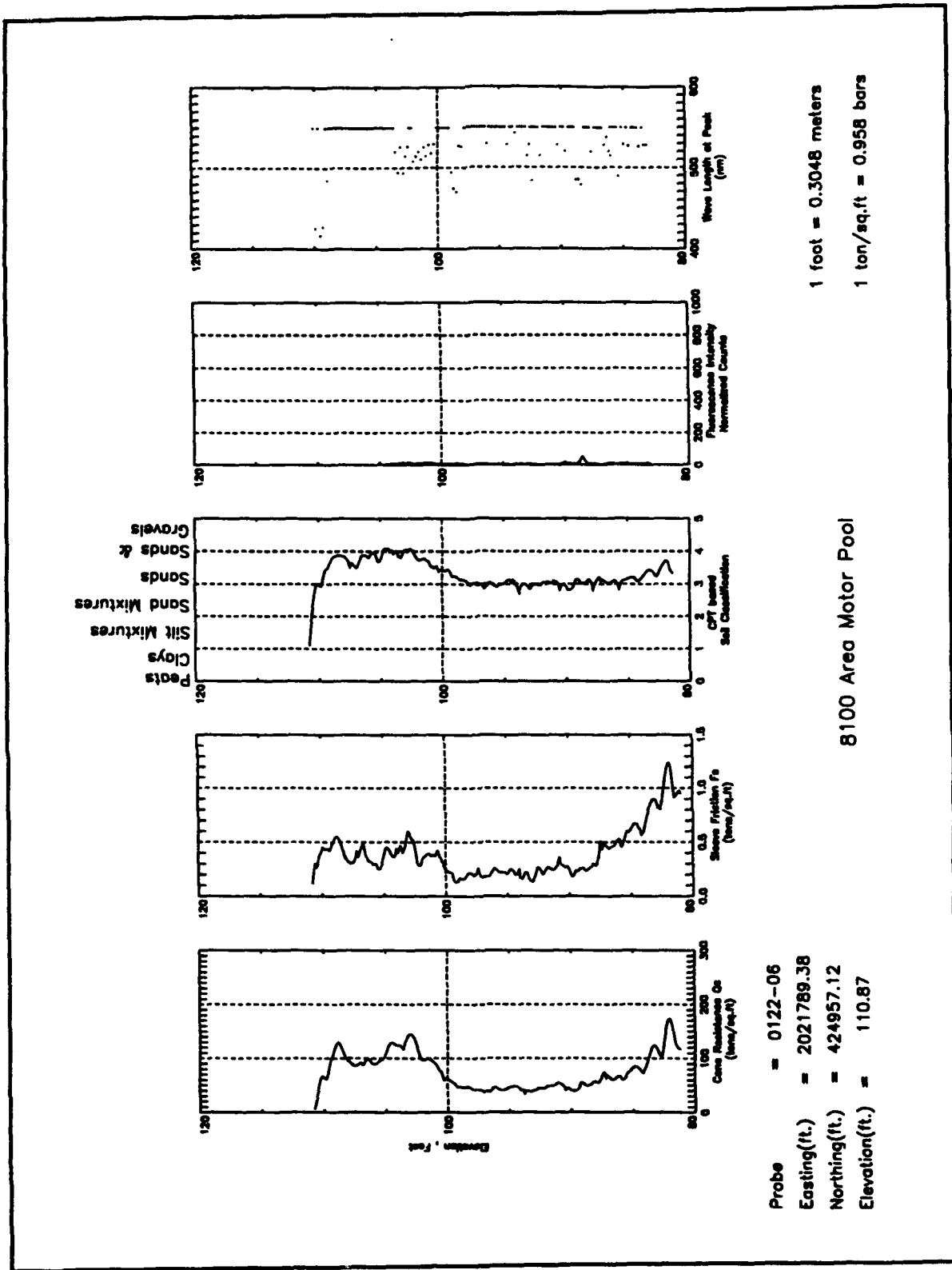

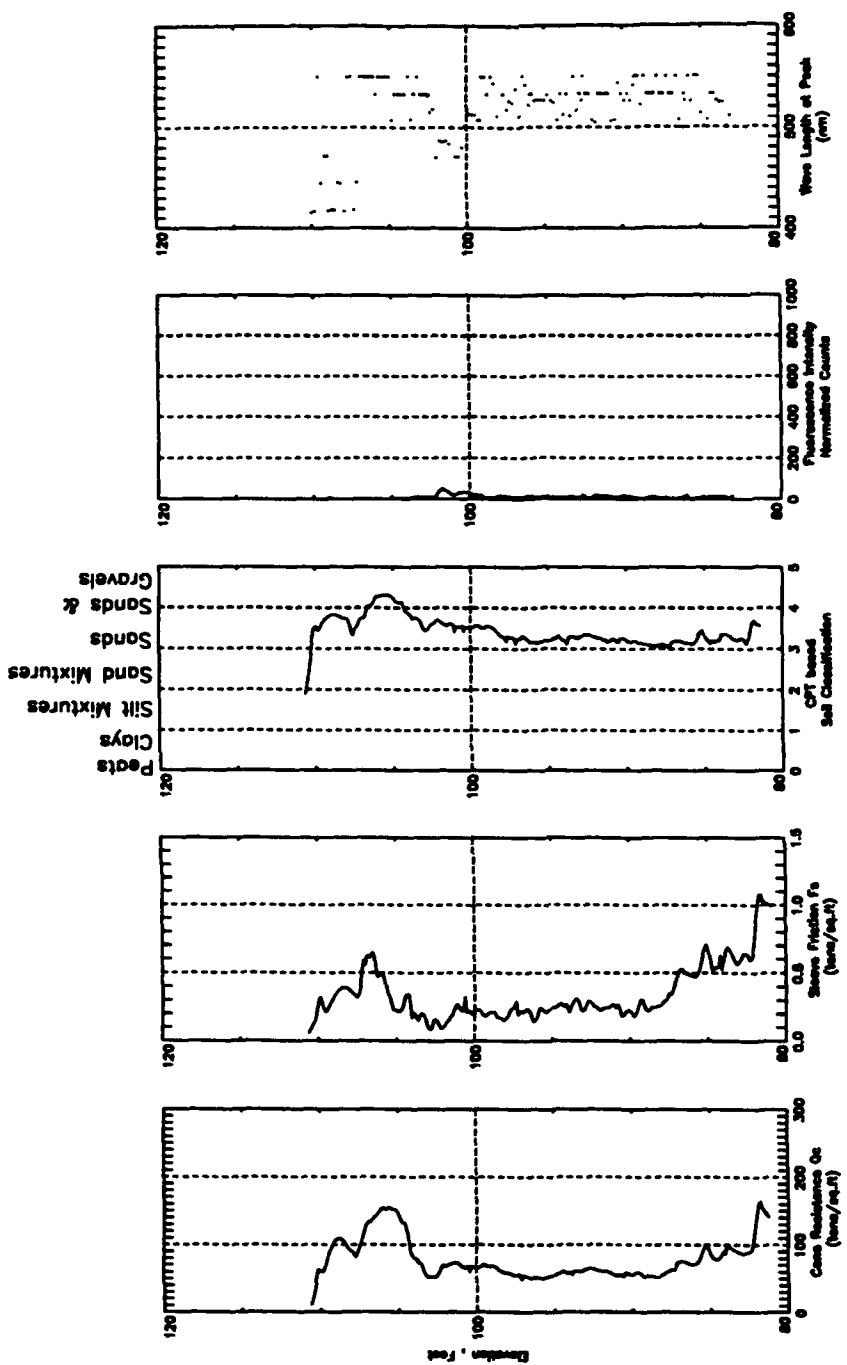

Probe = 0122-07
 Easting(ft.) = 2021752.00
 Northing(ft.) = 424841.91
 Elevation(ft.) = 110.72

1 foot = 0.3048 meters
 1 ton/sq.ft = 0.958 bars

8100 Area Motor Pool

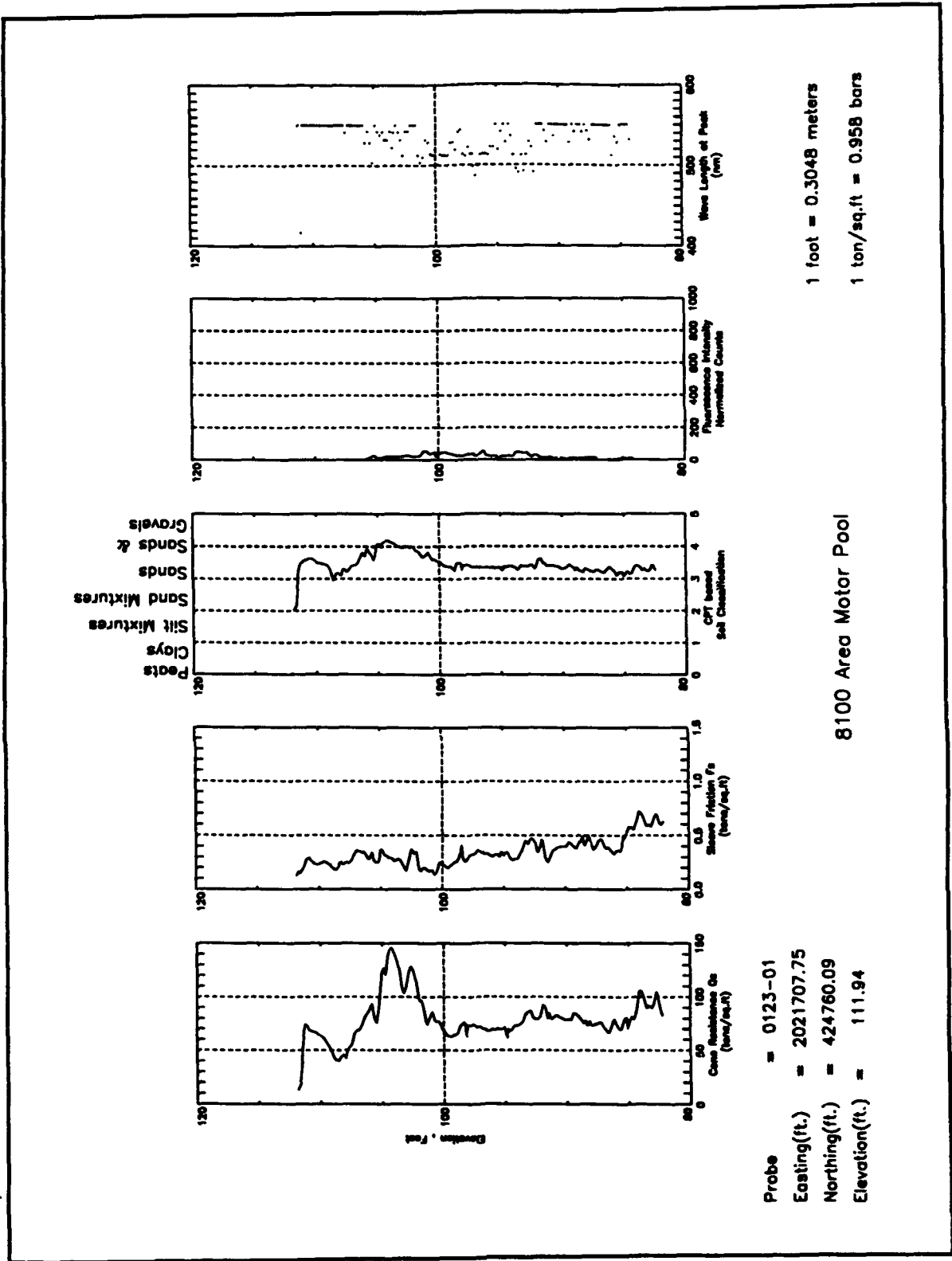

Probe = 0123-01
 Easting(ft.) = 2021707.75
 Northing(ft.) = 424760.09
 Elevation(ft.) = 111.94

1 foot = 0.3048 meters
 1 ton/sq.ft = 0.958 bars

8100 Area Motor Pool

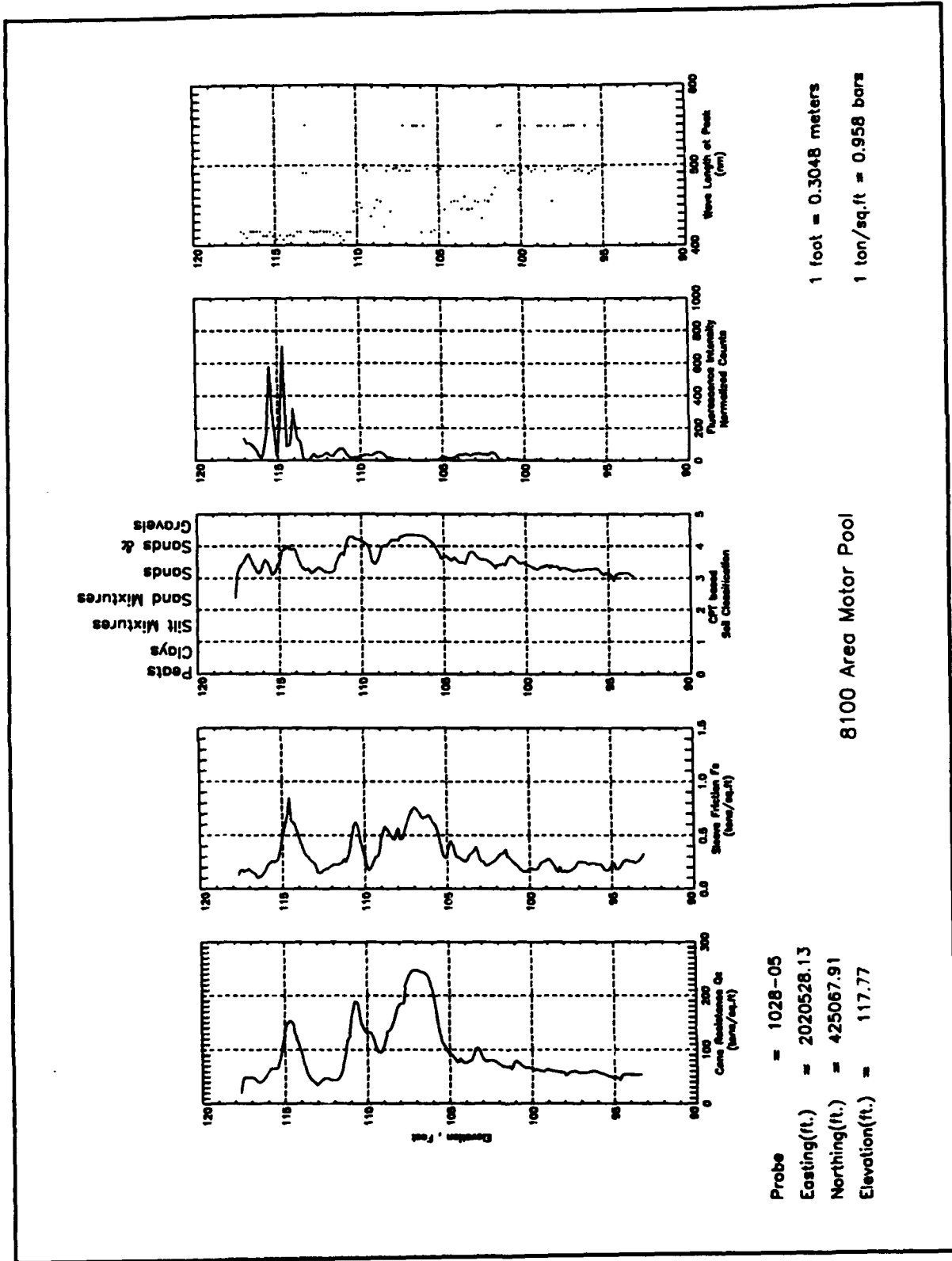

Probe = 1028-05
 Easting(ft.) = 2020528.13
 Northing(ft.) = 425067.91
 Elevation(ft.) = 117.77

8100 Area Motor Pool

1 foot = 0.3048 meters
 1 ton/sq.ft = 0.958 bars

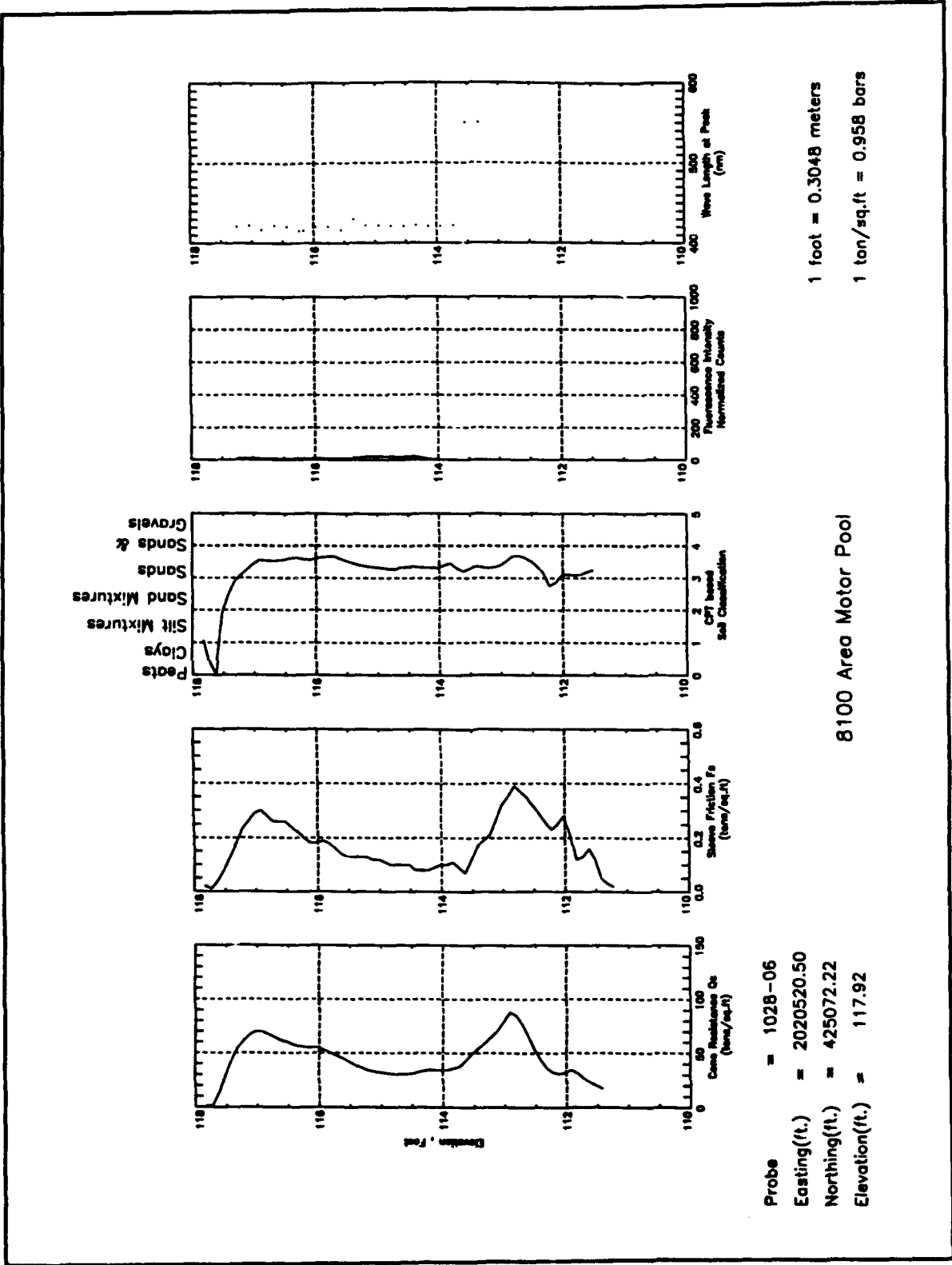

Appendix M

8132 Hazardous Waste Storage Area

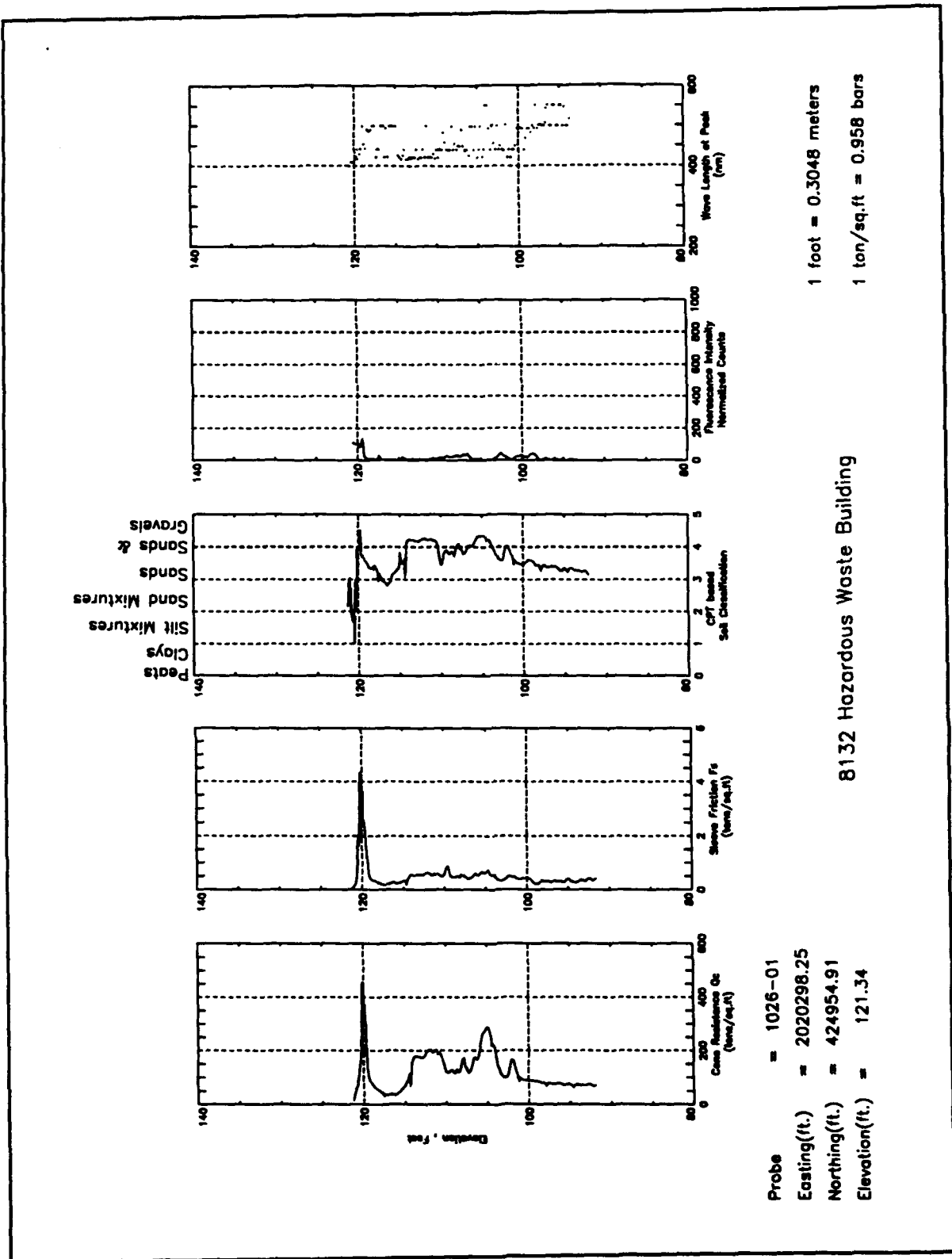

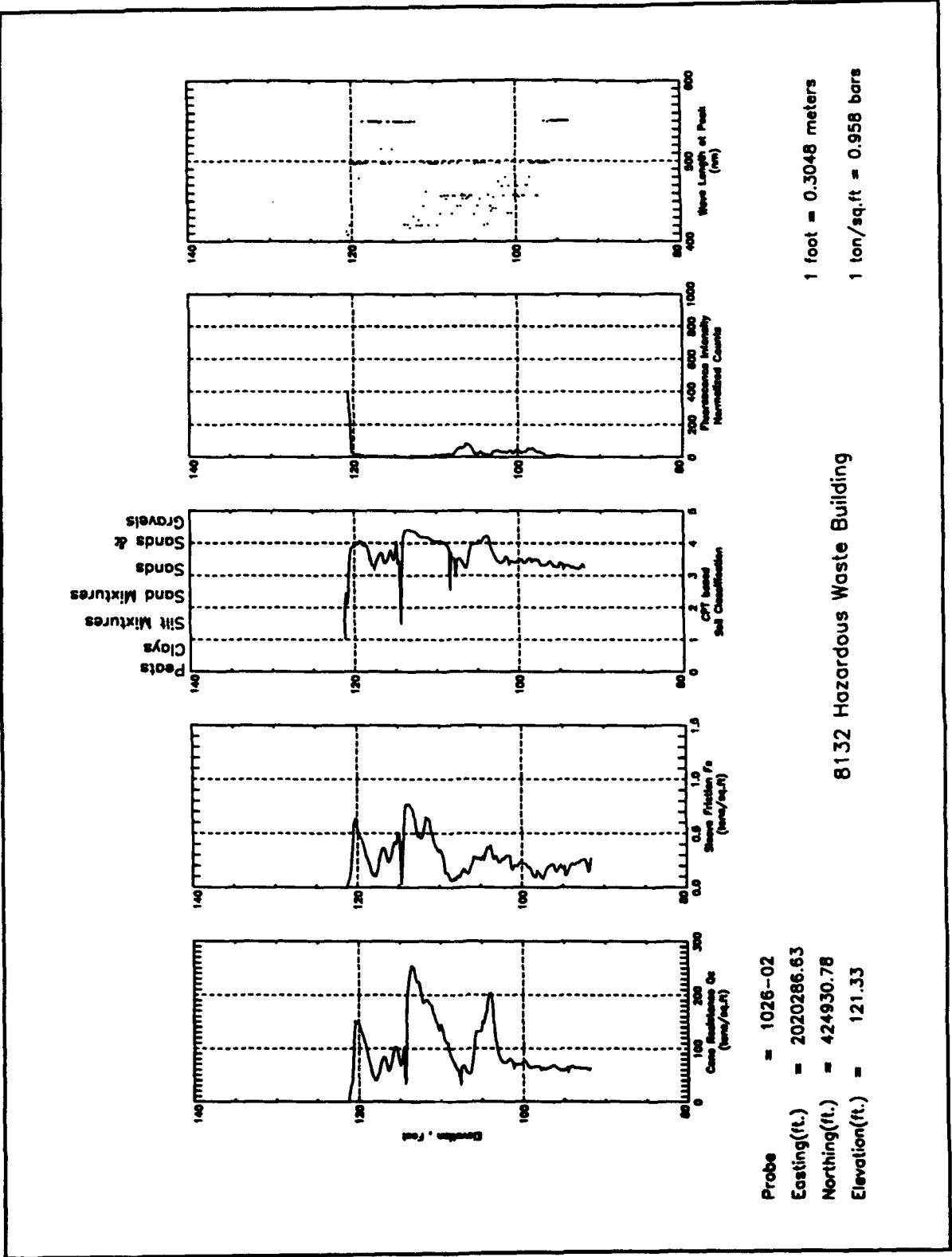

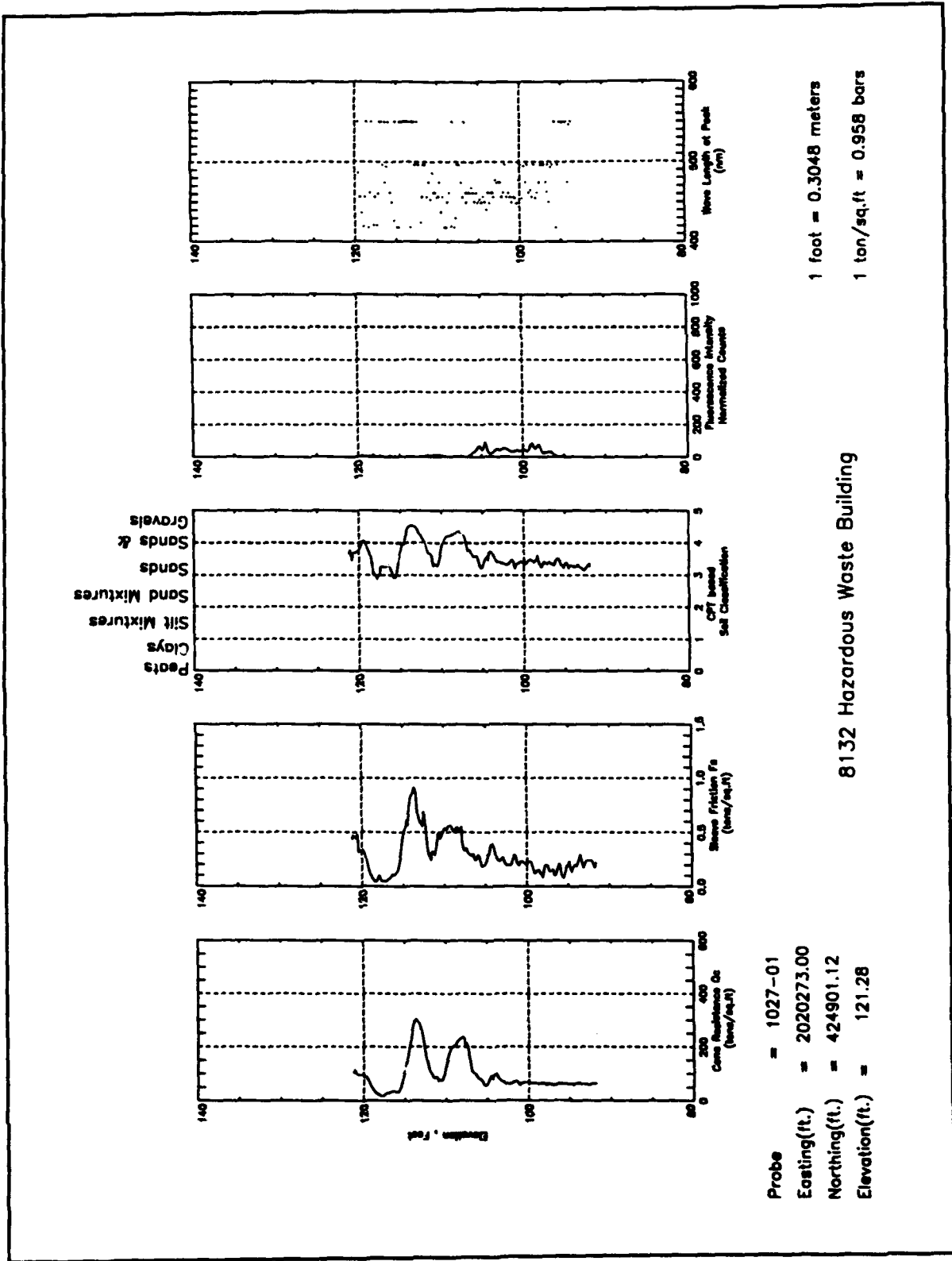

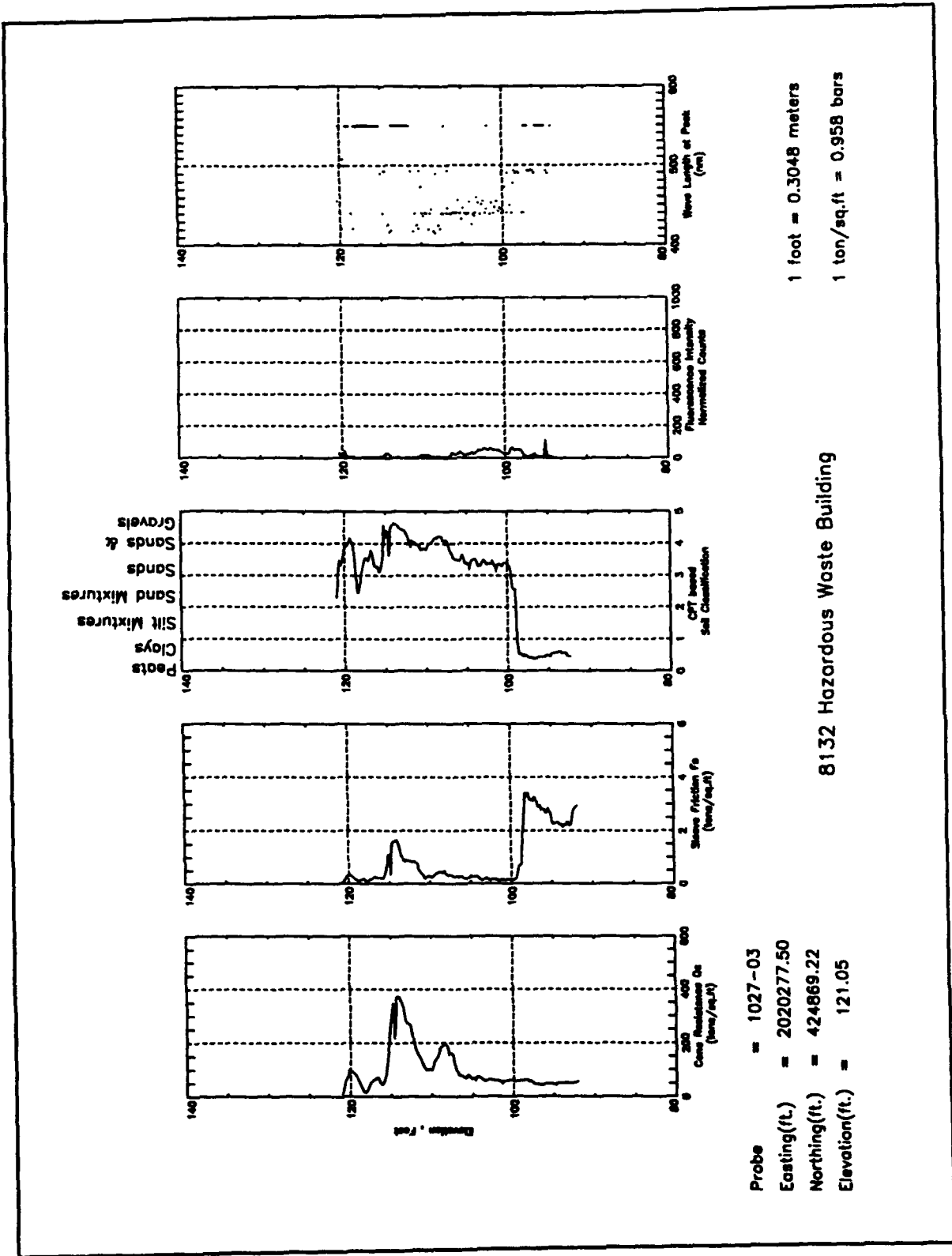

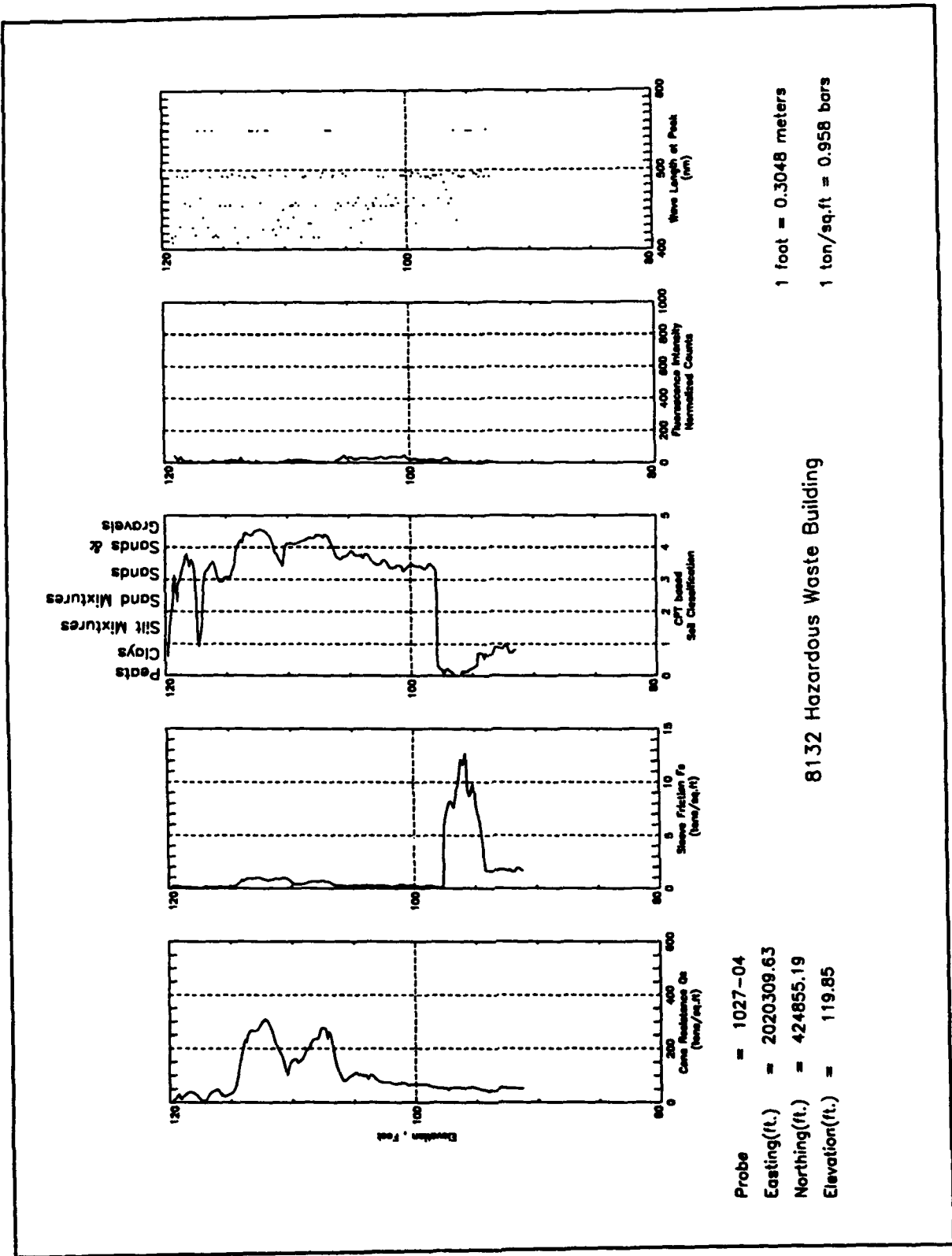

Probe = 1027-04
 Easting(ft.) = 2020309.63
 Northing(ft.) = 424855.19
 Elevation(ft.) = 119.85

8132 Hazardous Waste Building

1 foot = 0.3048 meters
 1 ton/sq.ft = 0.958 bars

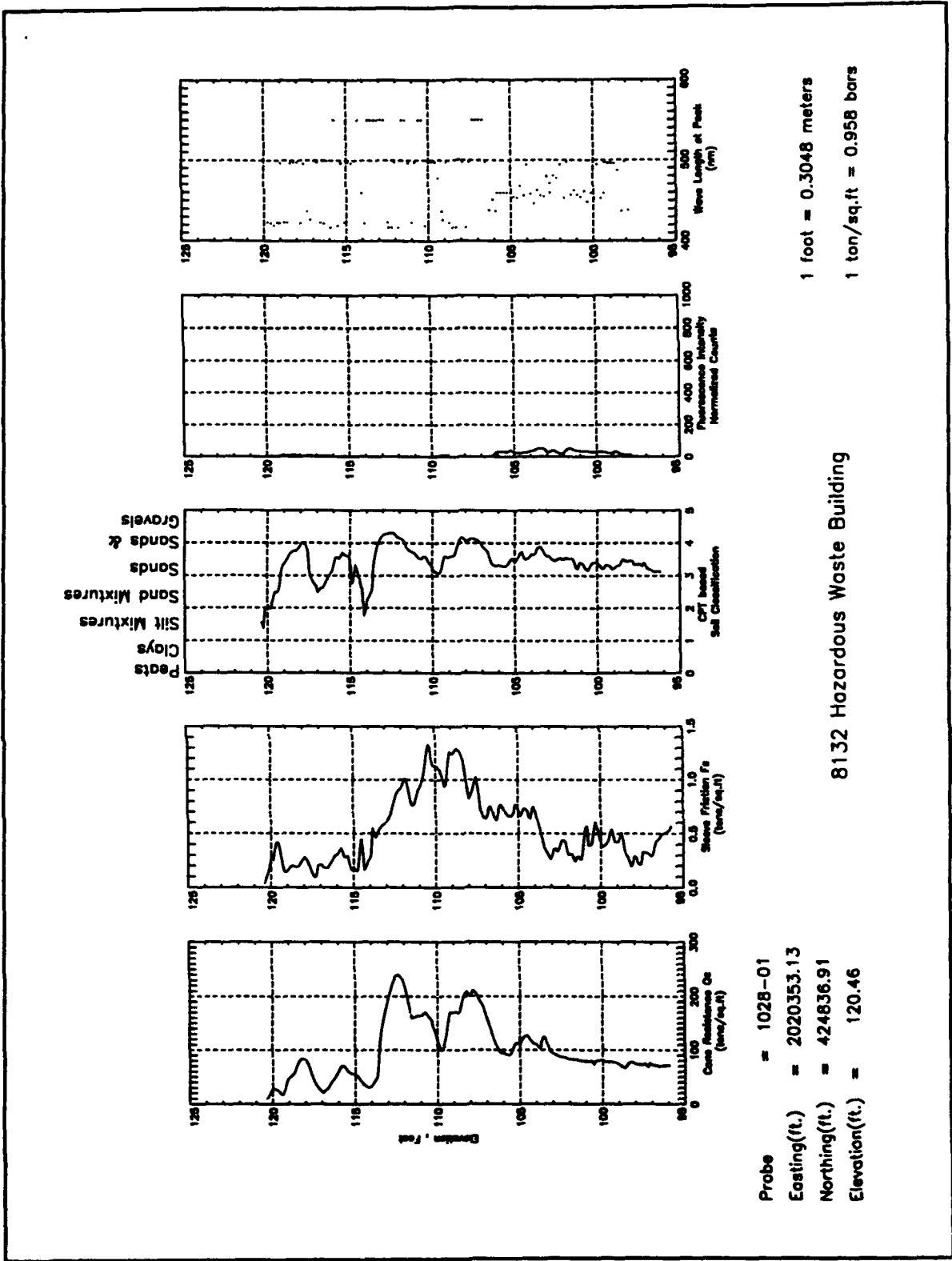

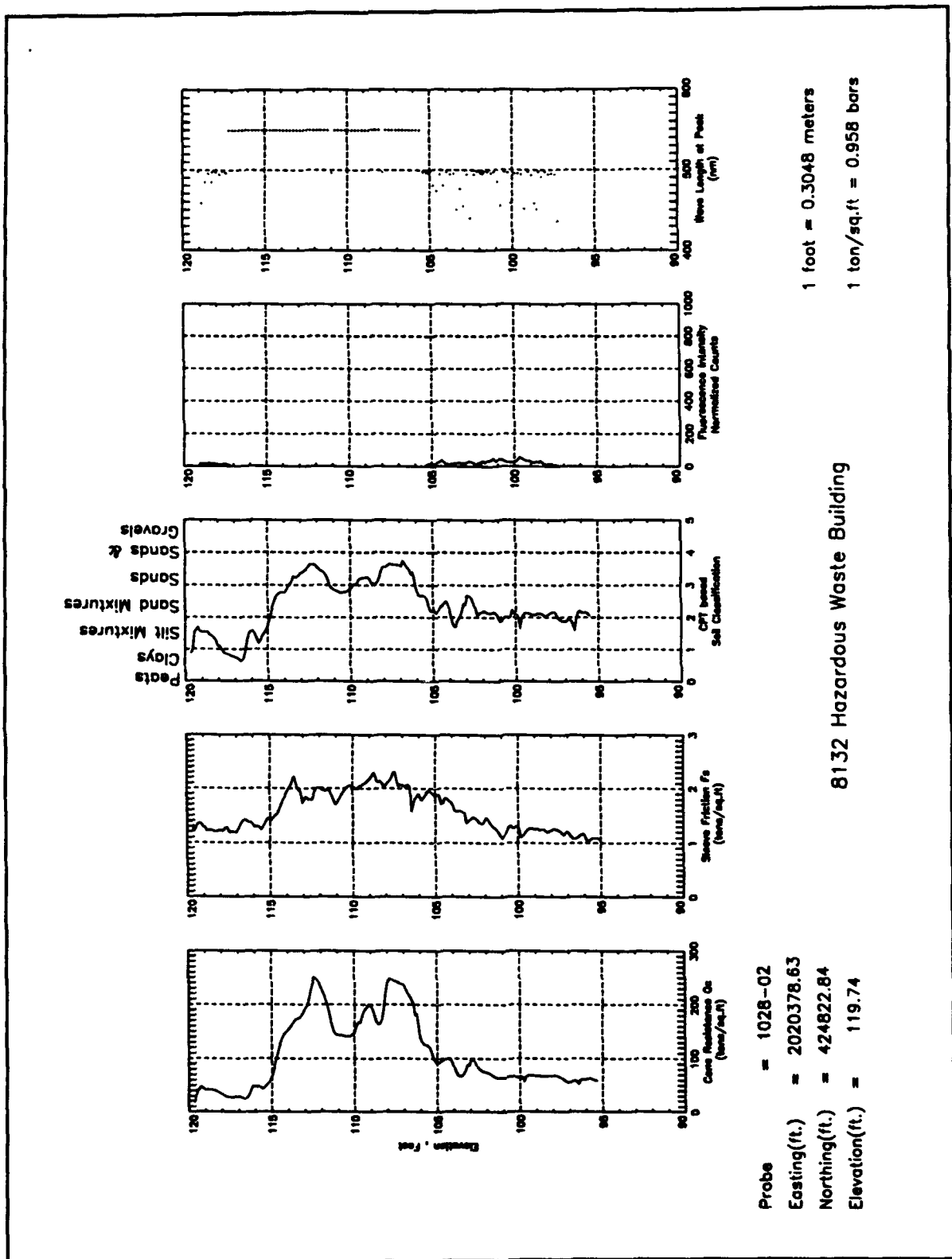

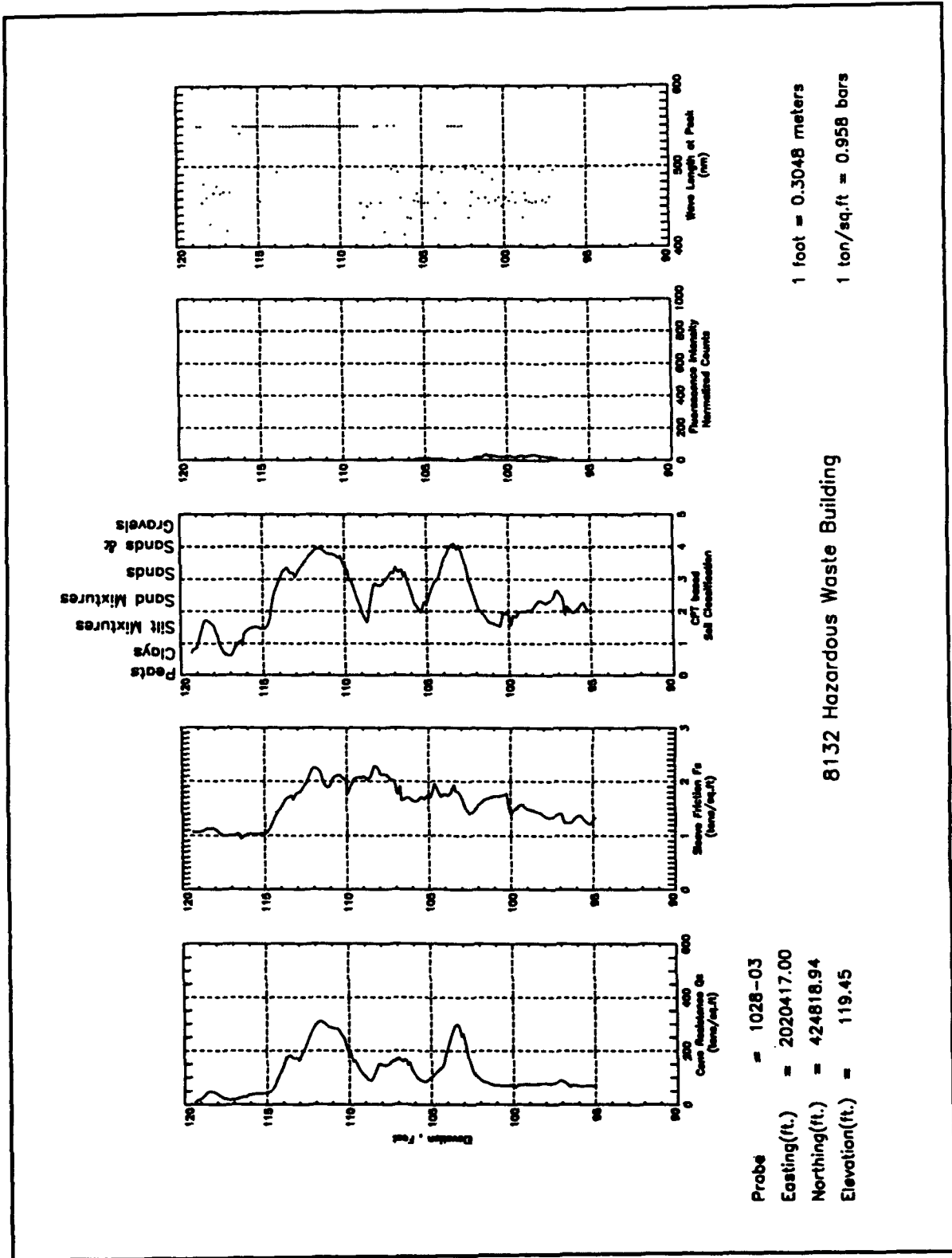

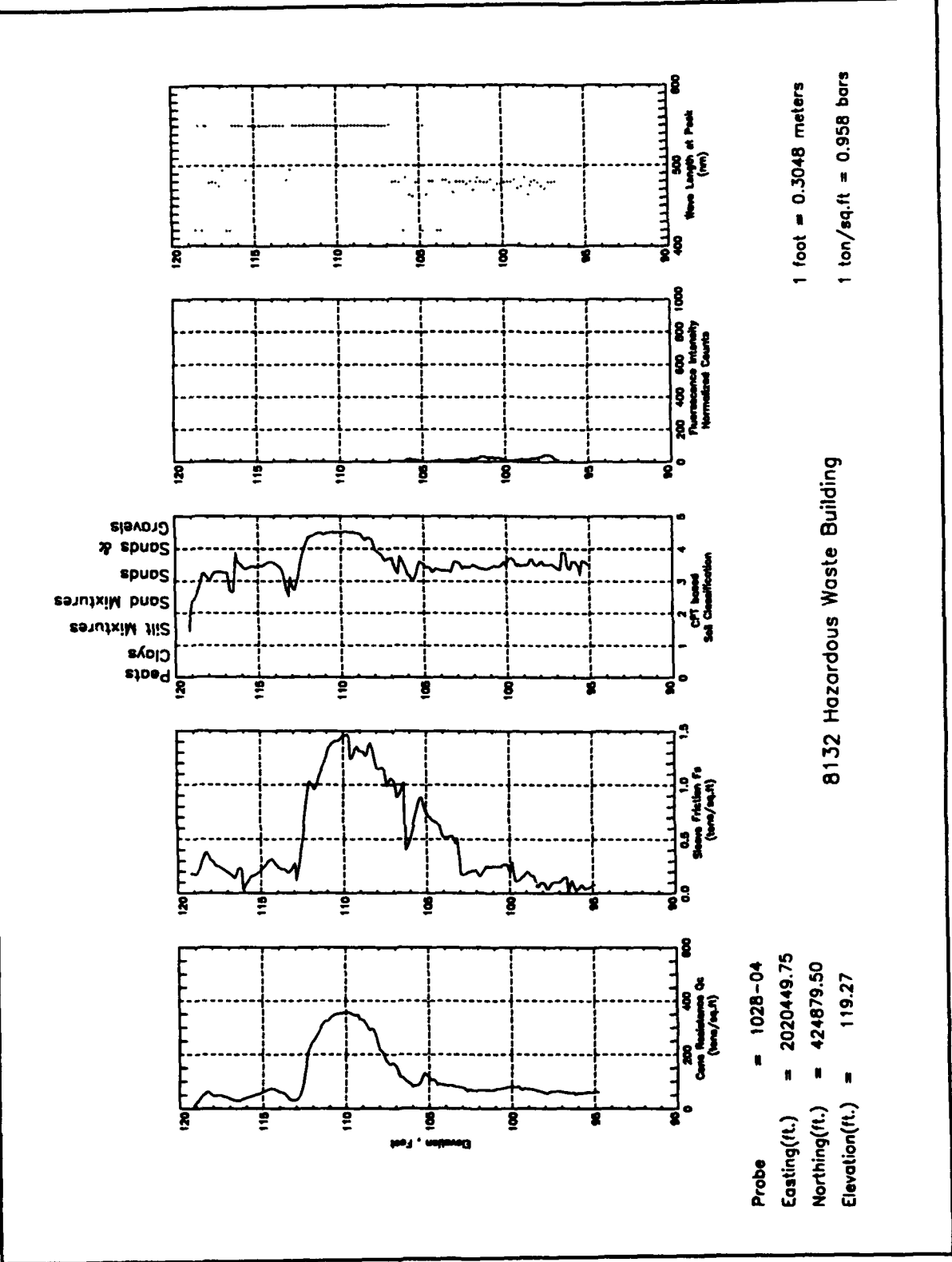

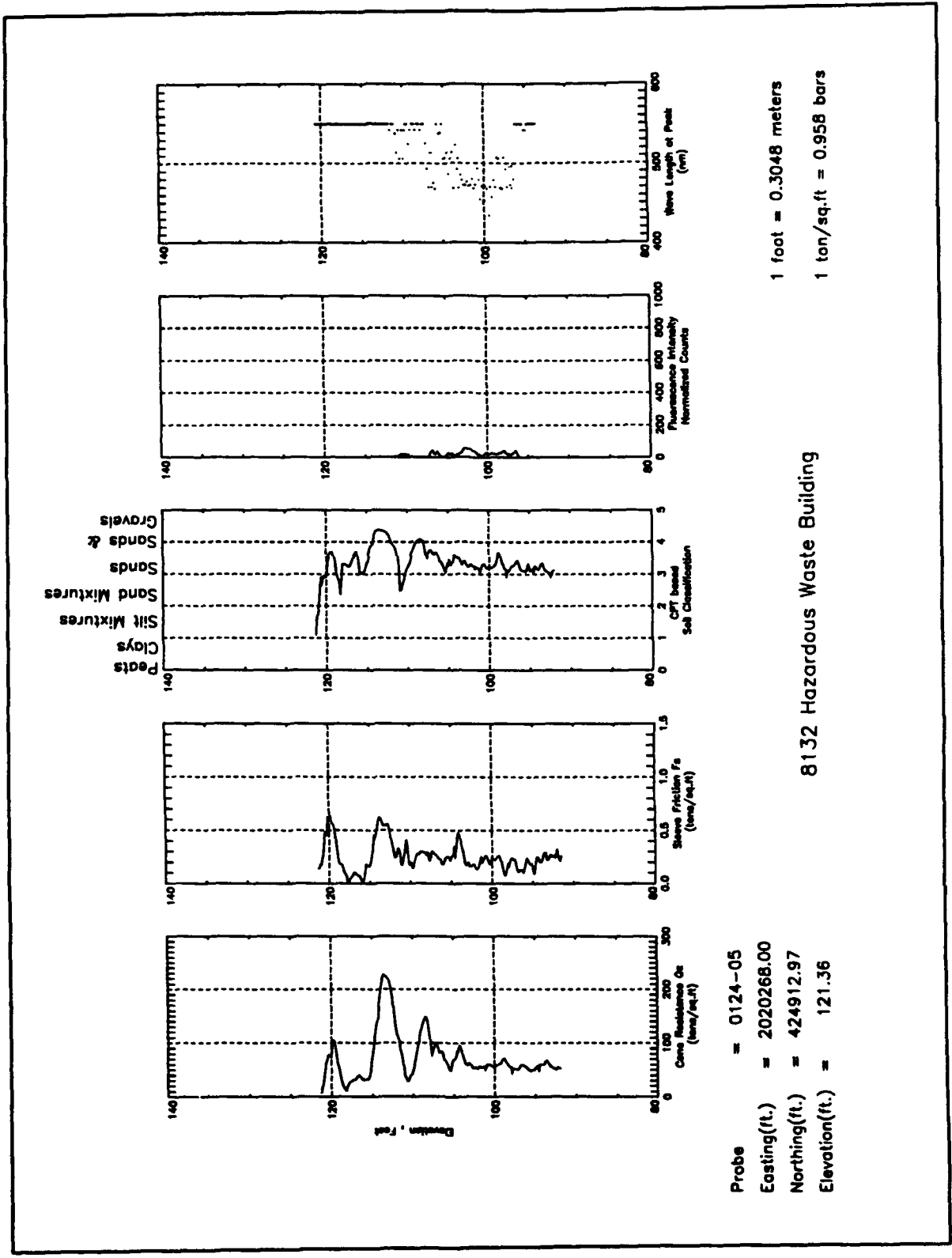

Probe = 0124-05
 Easting(ft.) = 2020268.00
 Northing(ft.) = 424912.97
 Elevation(ft.) = 121.36

8132 Hazardous Waste Building

1 foot = 0.3048 meters
 1 ton/sq.ft = 0.958 bars

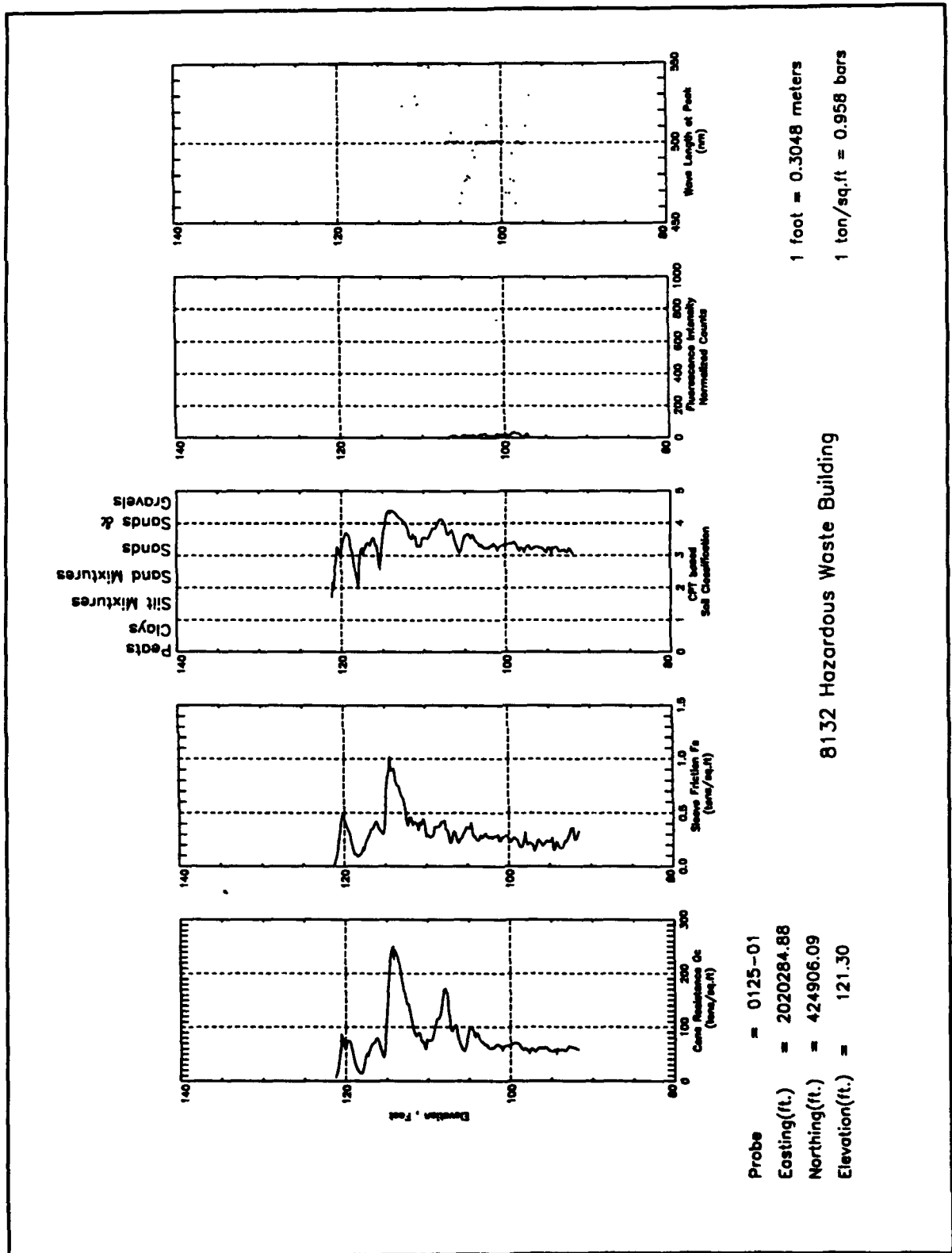

REPORT DOCUMENTATION PAGE

Form Approved
OMB No. 0704-0188

Public reporting burden for this collection of information is estimated to average 1 hour per response, including the time for reviewing instructions, searching existing data sources, gathering and maintaining the data needed, and completing and reviewing the collection of information. Send comments regarding this burden estimate or any other aspect of this collection of information, including suggestions for reducing this burden, to Washington Headquarters Services, Directorate for Information Operations and Reports, 1215 Jefferson Davis Highway, Suite 1204, Arlington, VA 22202-4302, and to the Office of Management and Budget, Paperwork Reduction Project (0704-0188), Washington, DC 20503.

1. AGENCY USE ONLY (Leave blank)	2. REPORT DATE July 1993	3. REPORT TYPE AND DATES COVERED Final report
-----------------------------------------	------------------------------------	---------------------------------------------------------

4. TITLE AND SUBTITLE Site Investigations with the Site Characterization and Analysis Penetrometer System at Fort Dix, New Jersey	5. FUNDING NUMBERS
---------------------------------------------------------------------------------------------------------------------------------------------	---------------------------

6. AUTHOR(S) Landris T. Lee, Jr., Amy M. Chrestman, Donald H. Douglas, Jeff F. Powell, and Philip G. Malone	
-----------------------------------------------------------------------------------------------------------------------	--

7. PERFORMING ORGANIZATION NAME(S) AND ADDRESS(ES) U.S. Army Engineer Waterways Experiment Station, Geotechnical Laboratory, Instrumentation Services Division, Structures Laboratory 3909 Halls Ferry Road, Vicksburg, MS 39180-6199	8. PERFORMING ORGANIZATION REPORT NUMBER Technical Report GL-93-17
----------------------------------------------------------------------------------------------------------------------------------------------------------------------------------------------------------------------------------------------------	---------------------------------------------------------------------------------

9. SPONSORING/MONITORING AGENCY NAME(S) AND ADDRESS(ES) U.S. Army Environmental Center Aberdeen Proving Ground, MD 21010-5401	10. SPONSORING/MONITORING AGENCY REPORT NUMBER
--------------------------------------------------------------------------------------------------------------------------------------------	-------------------------------------------------------

11. SUPPLEMENTARY NOTES This report is available from the National Technical Information Service, 5285 Port Royal Road, Springfield, VA 22161.

12a. DISTRIBUTION/AVAILABILITY STATEMENT Approved for public release; distribution is unlimited	12b. DISTRIBUTION CODE
-----------------------------------------------------------------------------------------------------------	-------------------------------

13. ABSTRACT (Maximum 200 words) Thirteen sites at Fort Dix, New Jersey, were investigated with the WES Site Characterization and Analysis Penetrometer System (SCAPS). The SCAPS performed detection screening for possible subsurface petroleum, oil, and lubricant (POL) contamination at each site. The truck-mounted laser-induced fluorometer packaged with the conventional cone penetrometer was utilized for this mission. Soil and groundwater verification sampling was also conducted. Possible POL contamination was found at 6 of the 13 sites investigated.

14. SUBJECT TERMS Cone penetrometer Laser induced fluorometer POL contamination	15. NUMBER OF PAGES 431
	16. PRICE CODE

17. SECURITY CLASSIFICATION OF REPORT Unclassified	18. SECURITY CLASSIFICATION OF THIS PAGE Unclassified	19. SECURITY CLASSIFICATION OF ABSTRACT	20. LIMITATION OF ABSTRACT
--------------------------------------------------------------	-----------------------------------------------------------------	------------------------------------------------	-----------------------------------