

AD-A268 805



AN ANALYSIS OF CAVITATION ACTIVITY AT
ORIFICES OF THE FFG-7 SEAWATER PIPING
SYSTEM

2

AR-006-260

M. CASTILLO

MRL-TN-637

MARCH 1993

DTIC
ELECTE
AUG 30 1993
S E D

APPROVED
FOR PUBLIC RELEASE

© Commonwealth of Australia

MATERIALS RESEARCH LABORATORY

DSTO

An Analysis of Cavitation Activity at Orifices of the FFG-7 Seawater Piping System

M. Castillo

MRL Technical Note
MRL-TN-637

Abstract

An analytical investigation has been made of cavitation in a number of pairs of orifice plates installed within the seawater cooling pipe lines of FFG-7 guided missile frigates. Four lines, where excessive noise and erosion have been reported, have been analysed; these are, the fire main recirculating line, the gas turbine start and bleed air cooler lines, and the prairie air cooler line. The results show that all circuits operate at exceedingly high levels of cavitation, much higher than the usual acceptable limit. The fire main line may suffer from supercavitation, possibly causing damage down stream from the second orifice. Sample design studies indicate that a simple multiple orifice plate arrangement may eliminate the problem.

93-20047

DEPARTMENT OF DEFENCE
DSTO MATERIALS RESEARCH LABORATORY

93 8 26 07 5

Published by

*DSTO Materials Research Laboratory
Cordite Avenue, Maribyrnong
Victoria, 3032 Australia*

Telephone: (03) 246 8111

Fax: (03) 246 8999

© Commonwealth of Australia 1993

AR No. 008-260

APPROVED FOR PUBLIC RELEASE

Contents

- 1. INTRODUCTION 5
- 2. ORIFICE CAVITATION 6
- 3. PROCEDURE 7
 - 3.1 Cavitation Analysis 7
 - 3.2 Data on FFG-7 Seawater Systems 8
 - 3.3 Simplifications 9
- 4. RESULTS 10
 - 4.1 Revised Flow Rates 10
 - 4.2 Cavitation Activity 10
- 5. DISCUSSION 11
- 6. RECOMMENDATIONS 16
- 7. CONCLUSIONS 17
- 8. LIST OF SYMBOLS 18
- 9. REFERENCES 18
- APPENDIX 1 - Pipe Friction Losses 20
- APPENDIX 2 - Pipe Bend Losses 22
- APPENDIX 3 - Multiple Orifice Plates 24

Accession For	
NTIS CRA&I	<input checked="" type="checkbox"/>
DTIC TAB	<input type="checkbox"/>
Unannounced	<input type="checkbox"/>
Justification	
By	
Distribution /	
Availability Codes	
Dist	Avail and/or Special
A-1	

DTIC QUALITY INSPECTED 3

An Analysis of Cavitation Activity at Orifices of the FFG-7 Seawater Piping System

1. Introduction

Despite over twenty years of service with the US Navy, the FFG-7 guided missile frigate has a number of noise related problems. During its service the U.S.N. have identified a number of sources of excessive noise and in some cases have proposed remedial modifications. The seawater cooling system is one such source of excessive noise. The USN have expressed concern regarding excessive noise emanating from orifice plates in the auxiliary seawater piping of this class of ship [1]. In particular, the orifice plates installed at the following circuits have been identified:

- fire-main recirculating line (RECIRC)
- gas turbine start air cooler line (GT SAC)
- gas turbine bleed air cooler line (GT BLEED)
- prairie air cooler line (PRAIRIE)

These orifice plates are flow control devices designed to give a fixed pressure drop. Each of the circuits contain two orifice plates located in series immediately downstream from the major component [2]. In three of the four cases the major component is a heat exchanger with the line ending downstream of the second orifice at an overboard discharge. The exception is the fire-main recirculating line. Here the line is a pump by pass which feeds into the pump suction line. This line ensures a minimum flow will occur through the pump in the event of a flow obstruction ahead of the pump discharge, necessary to prevent overheating. Figure 1 gives a diagram of the arrangement.

In this report a cavitation analysis is conducted of each of these orifices. The method compares predicted cavitation intensities of the plates with empirically determined cavitation limits.

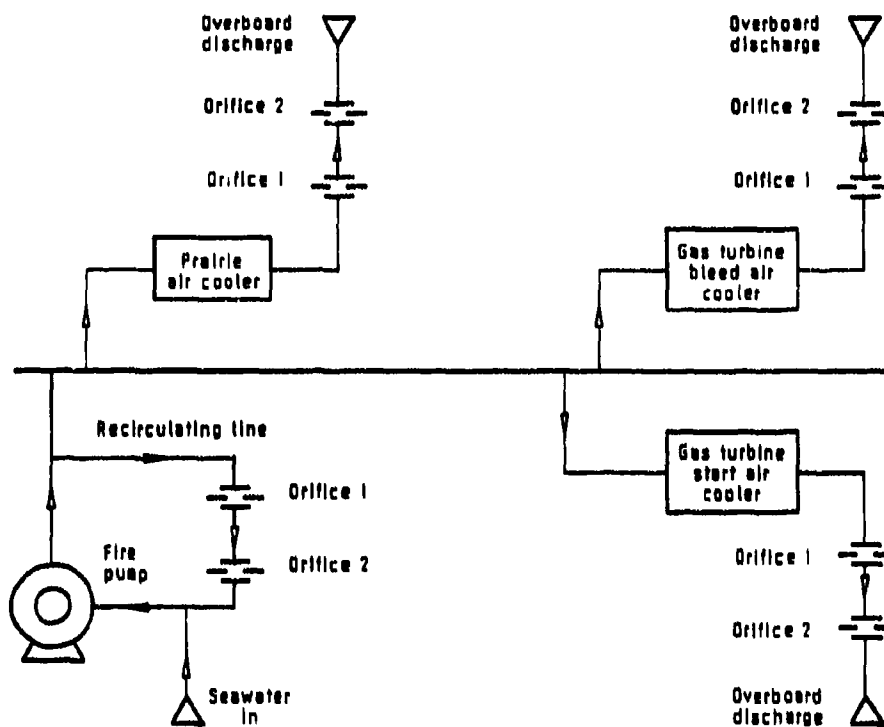

Figure 1: Schematic of relevant circuits.

2. Orifice Cavitation

In order to analytically determine the intensity of cavitation activity within a flow obstruction, such as an orifice, it is necessary to calculate a cavitation index [3]. This index is inversely proportional to the intensity of cavitation activity. That is, a low numerical value describes a high degree of cavitation. The index is defined as:

$$\sigma = (P_d - P_v) / \Delta P \quad (1)$$

where P_d is the fluid pressure downstream from the orifice, P_v is the fluid vapour pressure, and ΔP is the pressure drop across the orifice.

The intensity of cavitation can then be determined by comparing the index with empirically determined cavitation levels. Relevant levels are given below [4]:

- σ_i incipient cavitation
- σ_c critical cavitation
- σ_{id} incipient damage cavitation
- σ_{ch} choking cavitation

The incipient cavitation level is a highly conservative limit giving conditions at which no noise or vibration will be present in the flow [4]. In practice this limit is rarely used for design purposes.

The next level is the critical cavitation level and is usually regarded as the allowable limit of cavitation [4]. At this level noise is low and no damage will result [3,4].

An incipient damage level has been defined as the point at which pitting of soft aluminium specimens placed at the boundary is first detected [4]. While soft aluminium is perhaps not highly representative of the material used for the seawater piping (nickel copper alloy), the level can nevertheless be used as an approximate guide to the commencement of damage.

The choked condition is sometimes referred to as supercavitation. This condition occurs when the pressure downstream of the orifice drops to vapour pressure. Under this condition, damage may not occur at the orifice, however at some point downstream severe damage can occur [4]. Near the onset of choking, erosion damage, noise and vibration reach maxima [4].

3. Procedure

3.1 Cavitation Analysis

In order to find the cavitation index (equation 1) of a particular orifice, the pressure drop across that orifice and the pressure immediately downstream from it are required.

The pressure drop across the orifice was determined from a resistance factor, K . A plot of this resistance factor against the orifice-to-pipe diameter ratio was used to determine K [3]. The pressure drop was then determined via:

$$\Delta P = \frac{1}{2} \rho V^2 K \quad (2)$$

where V and ρ are the fluid velocity and density in the pipe respectively.

The pressure downstream from the orifice was then found by subtracting this pressure drop from the supply pressure. For the second orifice of the circuit, the pressure drop across both orifices was subtracted.

The cavitation levels reported in the literature were determined experimentally. These are plotted against the orifice discharge coefficient, C_d [4]. The discharge coefficient is a flow parameter used to correct for losses through an obstruction. It is related to the resistance factor by:

$$K = (1 - C_d^2) / C_d^2 \quad (3)$$

The discharge coefficient is fixed by the orifice-to-pipe diameter ratio. Existing charts can be used to find the discharge coefficient for a particular diameter ratio [4].

The plots of cavitation levels described above refer to specific reference conditions [4]. These values must generally be scaled to suit particular pipe sizes and pressures. The incipient and critical cavitation levels are not sensitive to

variations in pressure level, however they exhibit significant changes with pipe size. The incipient damage level shows no dependence on the pipe size, yet it exhibits significant variation with pipe pressure. Size or pressure scaling corrections were made via the empirical equations given [4]. The choking level of cavitation is fixed for a particular orifice-to-pipe diameter ratio, regardless of pipe size or pipe pressure. Therefore, in the case of choking, the value found from the plot was used directly.

There is a rapid method of determining the critical cavitation level for an orifice [3]. Here a plot is given of the critical cavitation level against the orifice-to-pipe diameter ratio for various pipe diameters. This method was used for comparison with the results from the previous method. The accuracy of this latter method is highly dependent on the ability to precisely pick values from plots and so should generally be regarded as less accurate.

3.2 Data on FFG-7 Seawater Systems

Information about the orifice plates, including flow rates, pipe internal diameter, water temperature and the orifice diameter is given in Table 1 [2].

Table 1: Orifice, Pipe and Flow Data [2]

Circuit	Flow Rate lpm (gpm)#	Pipe ID mm (in)	Temp °C (°F)	Orifice Diameter	
				First* mm (in)	Second*
RECIRC	189 (50)	38.5 (1.516)	ambient	14.29 (9/16)	14.29 (9/16)
GT SAC	300 (132)	56.2 (2.213)	37.8 (100)	21.03 (53/64)	26.59 (1-3/64)
GT BLEED	681 (180)	68.8 (2.709)	37.8 (100)	24.61 (31/32)	31.75 (1-1/4)
PRAIRIE	681 (180)	68.8 (2.709)	32.6 (90.7)	25.00 (63/64)	31.35 (1-15/64)

* First and second orifice refer to downstream position from the major assembly

Gallons (US) per minute

There are six pumps present that can service the seawater piping. One or two pumps is sufficient to provide the cooling requirements. It is anticipated that more than two pumps would only come into operation during emergencies, to meet fire-fighting requirements, when noise and vibration would not be primary considerations.

Each pump is designed to supply approximately 862 kPa (125 psi) gauge pressure at 3785 litres (1000 US gallons) per minute [8]. A pump performance curve is shown in Figure 2. If two pumps operate simultaneously, the flow requirement of each individual pump will halve from 3785 litres per minute (1000 gpm) to 1893 litres per minute (500 gpm). Figure 2 shows that this will lead to an increased supply pressure of approximately 1034 kPa gauge (150 psig).

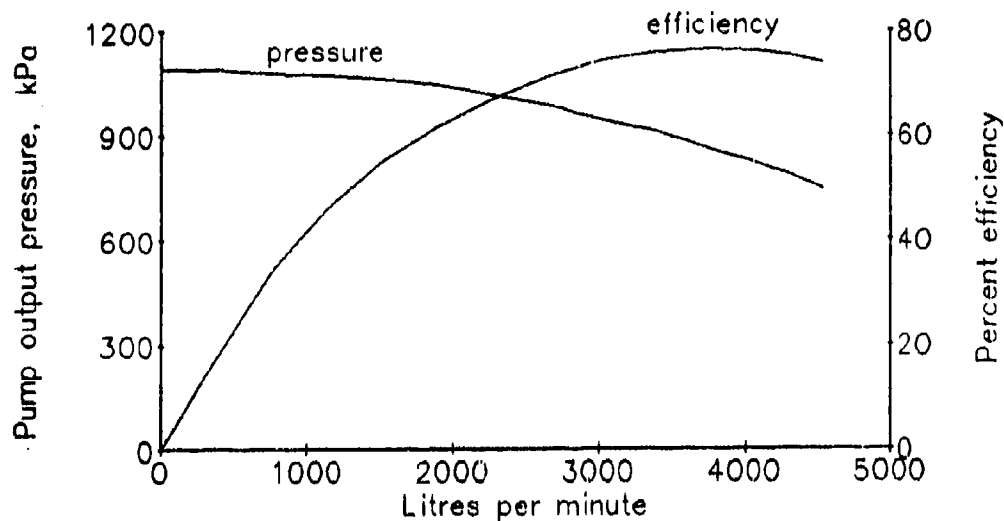

Figure 2: Pump performance curve [8].

3.3 Simplifications

The pressure at the first orifice of each circuit is equal to the pump supply pressure minus losses along the line. These losses include pipe friction losses, bend losses and losses at major assemblies (such as the heat exchangers).

Calculations have shown (refer to Appendix 1) that the normal head loss along the pipes is very small. The firemain recirculating line has the highest loss rate, yet this is only approximately 1.8 kPa per meter of pipe (0.079 psi per foot).

Physical observation of the sea water pipework on HMAS Melbourne under construction at Amecon, Williamstown, has revealed few bends. On most circuits there are no bends between the two orifices. Additionally, conservative estimates have shown, (refer to Appendix 2) that the pressure loss, even at a sharp bend, is less than 7 kPa (one psi).

Details of the relevant heat exchangers were not available. Drawings of two exchangers were obtained with similar geometry and flow characteristics to those in question. These exhibited pressure drops of only 9.0 kPa (1.3 psi) and 20.7 kPa (3.0 psi).

As a simplifying assumption the analysis assumed that the total pressure drop in each circuit occurs purely at the orifices. This means that the pressure immediately upstream of the first orifice is equal to the pump supply pressure, P_{sup} (gauge). The analysis was conducted at a range of pressure values. This also allowed investigation of the case where two or more pumps were operating at once.

4. Results

4.1 Revised Flow Rates

The flow rate through each circuit, and therefore through each orifice pair is highly dependent on the supply pressure. A higher supply pressure will allow a greater flow rate and correspondingly a larger pressure drop across each orifice (equation 2). This will in turn affect the orifice cavitation index (equation 1). The flow rates quoted in Table 1 are nominal values. These values were revised for the purpose of calculating the cavitation index at various supply pressures. The revised values are plotted in Figure 3, and are based on the resistance factors given in Table 2.

Table 2: Orifice resistance factors, K [3]

Circuit	Orifice 1	Orifice 2
RECIRC	134	134
GT SAC	125	40
GT BLEED	160	46
PRAIRIE	150	50

Figure 3 shows that the rate of flow through each circuit, for single pump operation, is approximately 20 litres per minute (about five U.S. gallons per minute) lower than that quoted at Table 1. This is disregarding losses occurring other than at the orifices. For two pump operation ($P_{SUP} = 1034$ kPa) the result is an increase of about 30 litres (8 gallons) per minute from the quoted rate. Concurrent operation of extra pumps will be associated with only limited increases in the circuit flow rates, as the pump supply pressure will rapidly approach its maximum (Figure 2).

4.2 Cavitation Activity

The cavitation characteristics of each orifice are presented graphically in Figure 4. The cavitation index is compared with the cavitation levels [4] described in section 2 of this report. The critical cavitation level found via the orifice rapid design technique [3], was found to be approximately 10 percent lower than that given in Figure 4.

Apart from the fire-main recirculating line, the plots are very similar for each of the first, and also each of the second orifices. This reflects the similarity of the arrangement both in terms of orifice geometry and flow conditions for each of the circuits.

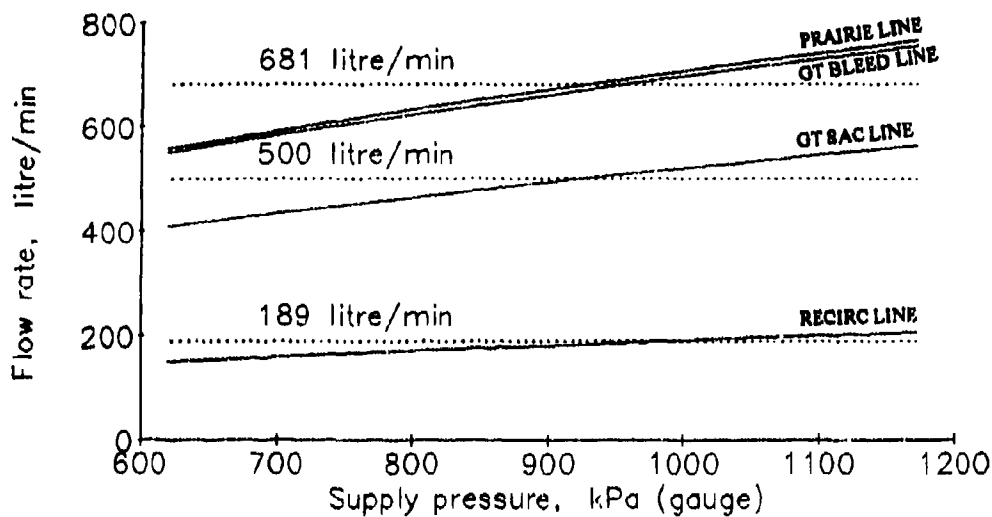

Figure 3: Flow rates through the circuits at various supply pressures.* (* ignoring line losses).

5. Discussion

It is apparent from Figure 4 that in all circuits cavitation is a problem. This is true irrespective of whether a single pump (862 kPa gauge pressure) or several pumps are considered to be operating (over 1034 kPa pump supply pressure). It applies for a 70 kPa line loss (considered excessive following the points raised in section 3.3) prior to the first orifice. The problem is in fact so severe that no realistic drop in the supply pressure will provide a satisfactory solution.

The orifices at the fire-main recirculating line reveal two extremes. The first orifice is operating at an exceptionally low level of cavitation, with a cavitation index well above the incipient cavitation level. On the other hand, the second orifice in this circuit is the worst offender of all the orifices investigated. This is operating with an index within the choking level.

This characteristic is attributed to the fact that this circuit is the only circuit with both orifices of identical size (see Table 1). This results in an identical pressure drop at both orifices. The first orifice can sustain a relatively large drop, since it is operating at a pressure very much higher than the vapour pressure. However, the second orifice is operating at a much lower pressure, and so an equivalent pressure drop will result in a large reduction of the cavitation index.

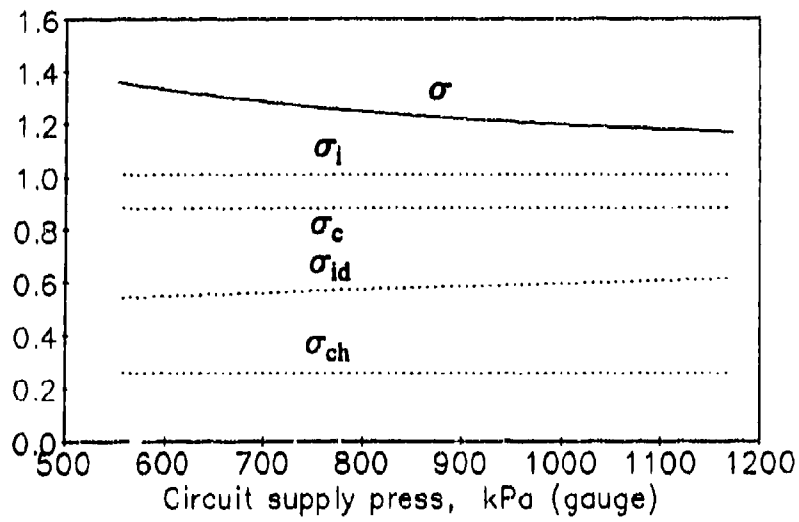

(a) Fire-main recirculating line. First orifice.

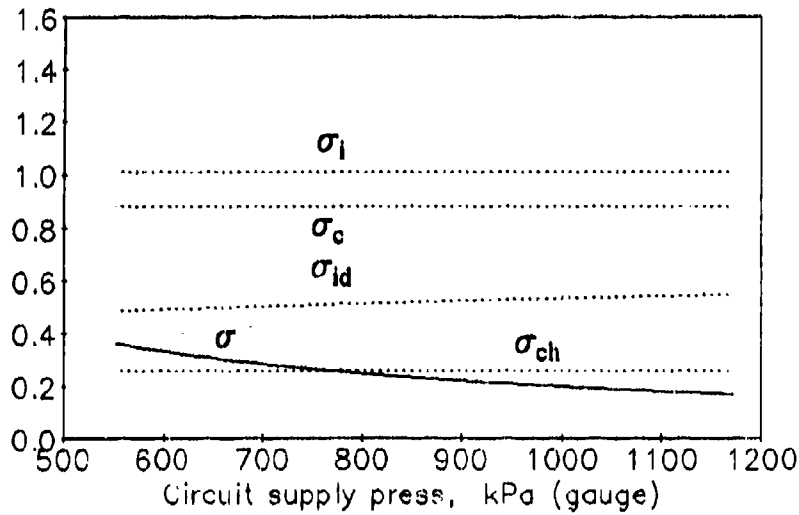

(b) Fire-main recirculating line. Second orifice.

Figure 4: Cavitation index and levels for each circuit at various supply pressures.

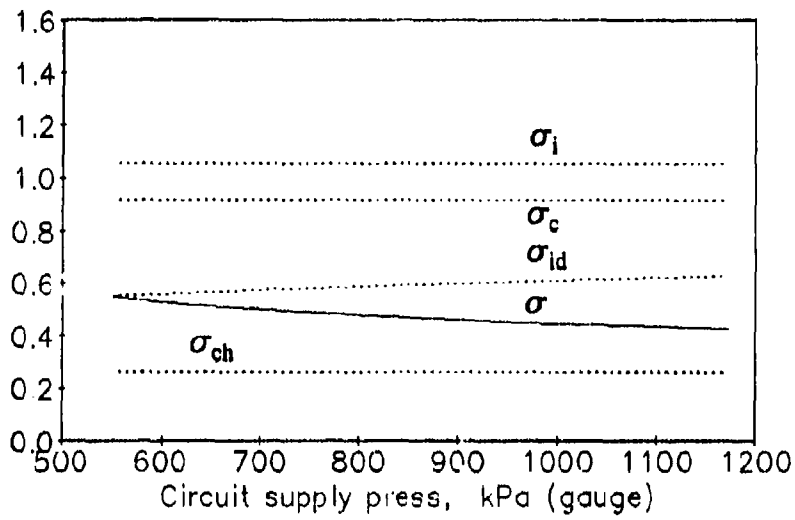

(c) Gas turbine start air cooler line. First orifice.

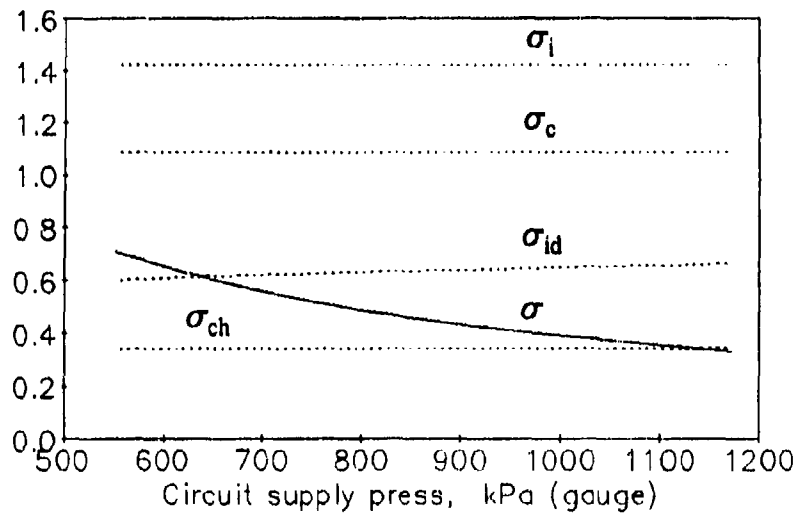

(d) Gas turbine start air cooler line. Second orifice.

Figure 4 (Contd): Cavitation index and levels for each circuit at various supply pressures.

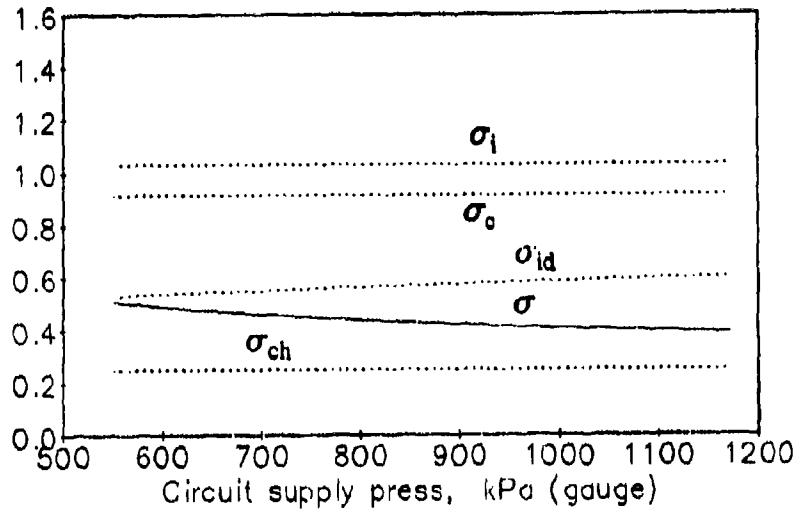

(e) Gas turbine bleed air cooler line. First orifice.

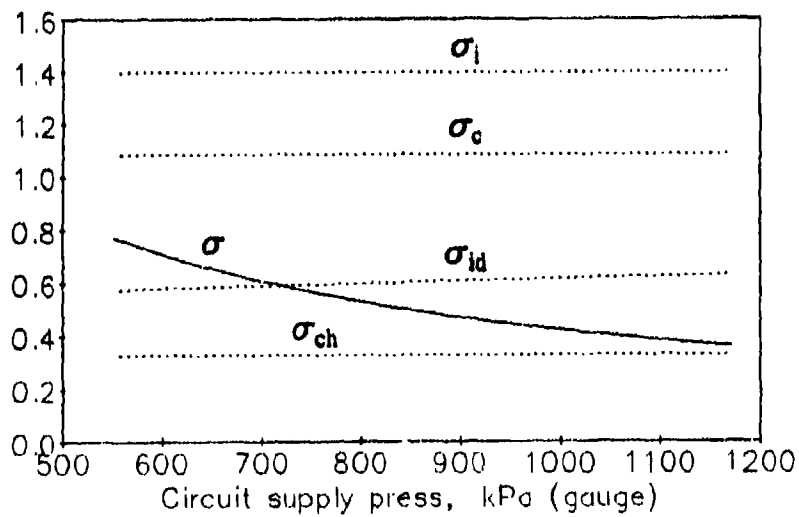

(f) Gas turbine bleed air cooler line. Second orifice.

Figure 4 (Contd): Cavitation index and levels for each circuit at various supply pressures.

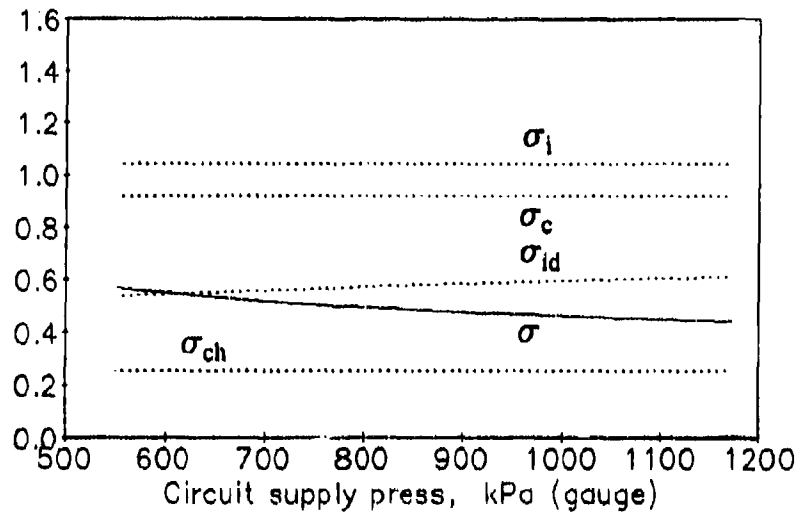

(g) Prairie air cooler line. First orifice.

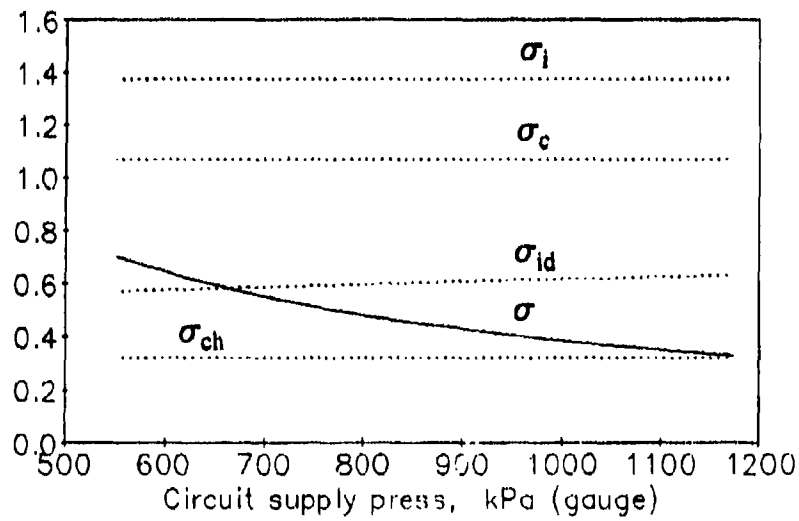

(h) Prairie air cooler line. Second orifice.

Figure 4 (Contd): Cavitation index and levels for each circuit at various supply pressures.

The conditions at the second orifice of the fire-main recirculating line are of prime concern for two reasons. Firstly, as mentioned in section 2 of this report, the onset of choking is associated with the most severe levels of damage, noise, and vibration. This means that reducing the supply pressure by some amount could conceivably aggravate the problem. As such, for this orifice, it is not immediately apparent whether or not single pump operation will be preferable to multiple pump operation.

The second cause for concern, potentially more serious, is the risk of damage to the pump. Section 2 states that under the condition of supercavitation damage may not occur at the orifice but may lead to severe damage at some distance downstream. This line feeds into the pump suction line.

All other circuits have orifices sized to give larger pressure drops at the first orifice. As such the cavitation index of the first orifice is of a similar magnitude to that of the second. Nevertheless these orifices are operating with an associated cavitation index within the damage level.

6. Recommendations

The most important recommendation to be made is that the cavitation intensity at the second orifice of the fire-main recirculating line (pump by-pass) be reduced. This could be achieved by increasing the pressure drop at the first orifice while reducing the drop at the second. This will make conditions at this line similar to those at the other circuits analysed. While this is far from ideal, it will mean the second orifice will no longer be choked, thus reducing noise and vibration levels, and eliminating the risk of severe damage occurring at the pump.

While no other orifice has a cavitation intensity as high as that of the second orifice in the pump bypass, all orifices studied are operating at unacceptable levels of cavitation. A solution could be provided by the use of multiple orifice plates [3]. By having a number of smaller pressure drops in series, the same overall pressure drop can be achieved without dropping the cavitation index below the critical level (usual design criteria) at any of the orifices. Appendix 2 gives some examples for the prairie air cooler circuit.

Another possible solution could be provided by the implementation of cascade orificial restrictive devices (CORD's) [9]. These too involve a number of plates in series. However, each plate in a CORD has many holes, rather than a single orifice. Multiple hole plates produce less noise and vibration and can be spaced close together [4]. In the case of multiple orifice plates the spacing has to allow the flow to fully develop between plates (see appendix 2). This can potentially lead to impractical lengths. Reference 9 gives design charts for the sizing of CORDS for various pressure drops, flow rates and pipe diameters. Figure 5 is an example of a CORD.

The author believes that the results of this analysis are severe enough that the simplifications made do not reduce the strength of the recommendations. The most important idealisation was that of ignoring line losses, a conservative simplification resulting in a higher pressure at the first orifice as well as an increased pressure drop across the orifice pair. This is equivalent to an increased pump supply pressure. However, the results have been presented as a function of supply pressure, and it is clear from these that the cavitation characteristics are not appreciably improved with realistic reductions of pressure.

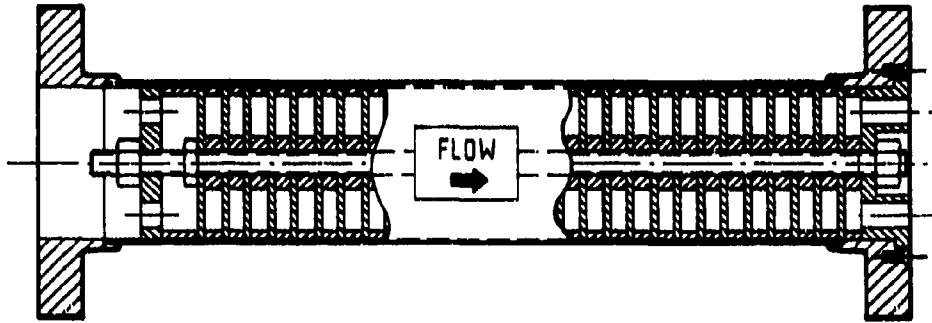

Figure 5: Example of cascade orifice restrictive device (CORD) [9].

7. Conclusions

The results of this analysis indicate that all circuits investigated suffer serious cavitation problems. At each of the orifice pairs, one or both of the orifice plates has a cavitation index which is numerically much lower than the critical level, that is, a cavitation intensity exceeding the usual design limit.

The orifice configuration at the fire-main recirculating line is of particular concern. Here the first orifice (downstream from the pump) operates free from cavitation, however the second orifice may be supercavitating (choked). This will cause damage downstream from the orifice and the pump may well be at risk.

It seems likely that a multiple orifice plate arrangement can provide a satisfactory solution.

8. List of Symbols

C_d	orifice discharge coefficient
d	pipe inside diameter
d_0	orifice diameter
f	pipe friction coefficient
g	acceleration of gravity
h_f	friction loss of head in pipe-line
K	resistance factor, loss coefficient
L	pipe length
P_d	down-stream pressure
P_{sup}	pump supply pressure
P_u	up-stream pressure
P_v	vapour pressure of water
Q	water flow rate
R	pipe bend radius
Re	flow Reynolds number
R_p	pipe inside radius
T	water temperature
V	water flow mean velocity
x	down-stream distance from orifice for complete flow pressure recovery
β	ratio of orifice to pipe inside diameter
z	height of pipe surface irregularities
θ	pipe bend angle
μ	water coefficient of viscosity
ρ	water density
σ	flow cavitation index
σ_c	critical cavitation level
σ_{ch}	choking cavitation level
σ_i	incipient cavitation level
σ_{id}	incipient damage cavitation level
ΔP	pressure drop

9. References

1. McNally, G.H.C. (Australian Frigate Project Director). Minute AFP 1674/E/90, N800/72/3 of 6 December 1990.
2. FFG-7 Seawater cooling system drawings. Dwg Nos. PF109-256-A010156 and PF109-5212-K09. US Naval Sea Systems Command.
3. Tung, P.C., Mikasinovic, M. (1983). Eliminating cavitation from pressure-reducing orifices. *Chemical Engineering*, 90 (25), pp. 69-71.

4. Tullis, J.P. (1989). *Hydraulics of pipelines*, pp. 119-174. New York: John Wiley & Sons.
5. Blevins, R.D. (1984). *Applied fluid dynamics handbook*, pp. 38-83. New York: Van Nostrand Reinhold.
6. *Mechanical engineer's reference book* (1973). (Ed.) A. Parrish. London: Butterworths.
7. *Handbook of chemistry and physics* (1990). (Ed.) D.R. Lide. Boston: CRC Press.
8. *Fire pump, centrifugal* (1985). NAVSEA 56225-RN-MMO-010/88032. New Jersey: Naval Ship Systems Command.
9. Cord drawings. Dwg. No. 5196808. US Naval Sea Systems Command.

Appendix 1

Pipe Friction Losses

The loss of head, h_f , in a pipe is estimated by the well known D'Arcy equation [6]:

$$h_f = \frac{4fLV^2}{2gd} \quad (4)$$

where f is the friction coefficient, L the length of pipe, V the fluid velocity, g the acceleration of gravity, and d is the pipe diameter. The actual pressure loss, per unit length of pipe, follows thus:

$$\Delta P = \rho gh_f = 2f\rho V^2 / d \quad (5)$$

where ρ is the fluid density.

The friction coefficient depends on the flow Reynolds number and the pipe relative roughness. The Reynolds number is given by $Re = \rho Vd / \mu$, where μ is the fluid viscosity. The relative roughness, ϵ/d , is the ratio of height of the surface irregularities to the pipe diameter.

Using the pipe and flow data at Table 2, the Reynolds number can be determined.

firemain recirc line:

$$\begin{aligned} Q &= 189 \text{ litre/min} \\ d &= 38.5 \text{ mm} \\ T &= \text{ambient sea water temp.} \end{aligned}$$

$$\begin{aligned} V &= 4Q / \pi d^2 = 4(189 \times 10^{-3} / 60) / \pi (38.5 \times 10^{-3})^2 \\ &= 2.71 \text{ m/s} \end{aligned}$$

$$\begin{aligned} \rho &= 999.1 \text{ kg/m}^3 \\ \mu &= 1.308 \times 10^{-3} \text{ kg/m.s} \end{aligned}$$

$$Re = 7.96 \times 10^4$$

gas turbine start air cooler line:

$$\begin{aligned} Q &= 500 \text{ litre/min} \\ d &= 56.2 \text{ mm} \\ T &= 37.8^\circ\text{C} \end{aligned}$$

$$\begin{aligned} V &= 3.35 \text{ m/s} \\ \rho &= 994.1 \text{ kg/m}^3 \\ \mu &= 0.723 \times 10^{-3} \text{ kg/m.s} \end{aligned}$$

$$Re = 2.75 \times 10^5$$

gas turbine bleed air cooler line:

$$\begin{aligned} Q &= 681 \text{ litre/min} \\ d &= 68.8 \text{ mm} \\ T &= 37.8^\circ\text{C} \\ \\ V &= 3.05 \text{ m/s} \\ \rho &= 994.1 \text{ kg/m}^3 \\ \mu &= 0.723 \times 10^{-3} \text{ kg/m.s} \\ \\ Re &= 3.05 \times 10^5 \end{aligned}$$

prairie air cooler line:

$$\begin{aligned} Q &= 681 \text{ litre/min} \\ d &= 68.8 \text{ mm} \\ T &= 32.6^\circ\text{C} \\ \\ V &= 3.05 \text{ m/s} \\ \rho &= 995.7 \text{ kg/m}^3 \\ \mu &= 1.595 \times 10^{-3} \text{ kg/m.s} \\ \\ Re &= 2.73 \times 10^5 \end{aligned}$$

Charts exist which give curves of the friction coefficient against the Reynolds number for various values of relative roughness. Such a chart [6] was used to determine the friction values shown on Table 3. The value for the height of the surface irregularities was taken as $\epsilon = 0.0015$ mm. This value is quoted for drawn pipe [6]. Table 3 also gives the relevant rates of pressure loss per metre length of pipe (from equation 5).

Table 3: Pipe Friction Pressure Losses

Circuit	$(10^5) Re$	$(10^{-5}) \epsilon/d^\#$	f^*	ΔP Loss per Metre of Pipe (kPa/m)
RECIRC	0.796	3.9	0.0047	1.79
GT SAC	2.75	2.7	0.0037	1.47
GT BLEED	3.05	2.2	0.0036	0.973
PRAIRIE	2.73	2.2	0.0037	0.995

From existing chart [6].

* $\epsilon = 0.0015$ mm for drawn pipe [6].

Appendix 2

Pipe Bend Losses

The loss in pressure due to fluid passing through a pipe bend can be given by a loss coefficient, K (similar to the resistance factor for orifices), as such:

$$\Delta P = K \cdot \frac{1}{2} \rho V^2 \quad (6)$$

where ρ is the fluid density and V the fluid velocity.

The value of K depends on the flow Reynolds number, $Re = \rho V d / \mu$ (where μ is the fluid viscosity and d the pipe diameter), the severity of the bend, R/d (where R is the bend radius), and the bend angle, θ [5]. Figure 6 show the parameters involved.

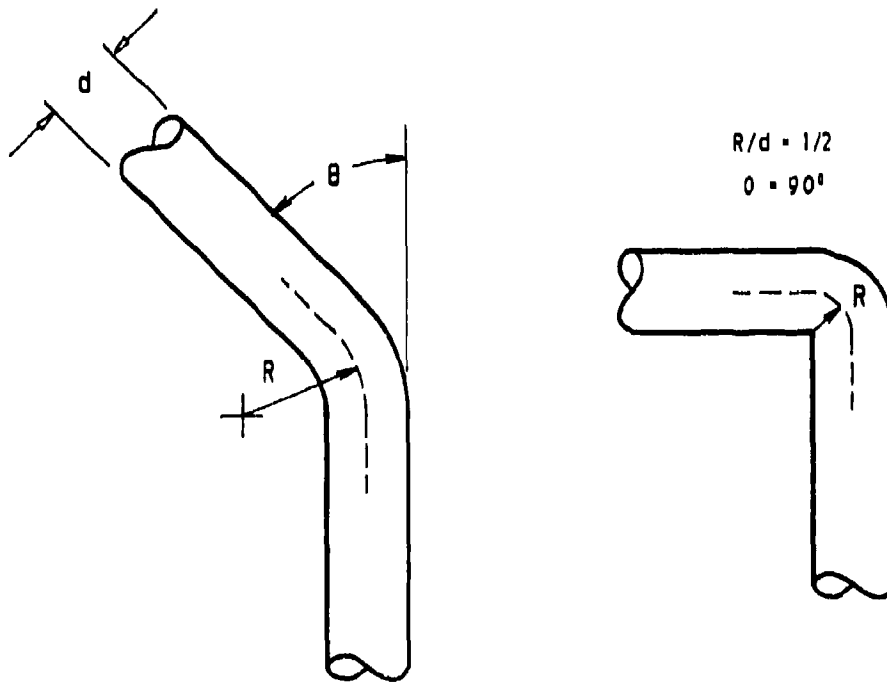

Figure 6: Pipe bend parameters.

A conservative estimate can be made by limiting the analysis to the case of sharp, right angled bends (see Fig. 6). This will give us $\theta = 90^\circ$ and $R/d = 1/2$. The loss coefficient for Reynolds numbers less than 5×10^5 can be found from [5].

$$K_{Re} = (K_{Re \geq 5 \times 10^5}) (5 \times 10^5 / Re)^{0.17} \quad (7)$$

where $K_{Re \geq 5 \times 10^5}$ is the loss coefficient for $Re \geq 5 \times 10^5$. For $\theta = 90^\circ$ and $R/d = 1/2$, we have [6]:

$$K_{Re \geq 5 \times 10^5} = 1.1$$

The Reynolds number and other flow parameters have been determined at Appendix 1 for each circuit. These values can be inserted into equations 6 and 7 to give the losses shown in Table 4.

Table 4: Pipe Bend Losses

Circuit	$(10^5) Re$	K^*	$1/2 \rho V^2$ (kPa)	ΔP Loss Per Pipe Bend* (kPa)
RECIRC	0.796	1.37	3.68	5.05
GTRB START	2.75	1.22	5.58	6.81
BLEED	3.05	1.20	4.61	5.54
PRAIRIE	2.73	1.22	4.62	5.63

* Conservatively bends are assumed to have $\theta = 90^\circ$ and $R/d = 1/2$.

Appendix 3

Multiple Orifice Plates

1. Design to Critical Cavitation Level

A number of orifice plates in series (Fig. 7) can provide a gradual pressure drop to avoid cavitation. In this appendix, the two orifice plates in the prairie air cooler circuit are replaced by a multiple plate system. Each orifice plate is sized to provide the maximum pressure drop without actually exceeding the design cavitation level (in this case the critical level, σ_c). It is important to maximise the pressure drop at each orifice, as this will reduce the total number of plates necessary.

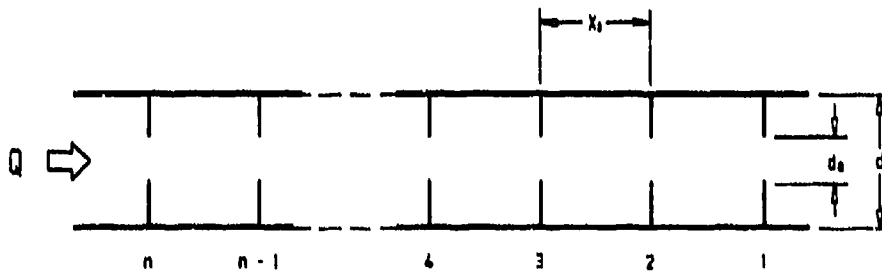

Figure 7: Multiple orifice plate system with "n" plates.

From Table 2 and Appendix 1 we have the following data for the prairie air cooler circuit:

- Q = 681 litre/min
- d = 68.8 mm ,pipe internal diameter.
- ρ = 994.1 kg/m³ ,fluid density.
- P_v = -96.4 kPa gauge ,fluid vapour pressure [7].

Also assume:

- P_u = 827 kPa gauge, pressure immediately upstream of multiple orifice.
- ΔP = 827 kPa gauge, total required pressure drop.

The procedure is based on that of reference [3]. Each orifice is sized successively, commencing at the downstream end (i.e. orifice 1). The method requires a first guess at the orifice to pipe diameter ratio, $\beta = d_0/d$. This is used to determine the resistance factor, K , which then gives the orifice pressure drop (equation 2). Equation 1 is then used to determine the cavitation index for the orifice, σ , which can be compared to the critical level, σ_c . If $\sigma < \sigma_c$ then a new smaller value of β

has to be used. This is continued until a satisfactory cavitation index is achieved. The whole procedure is repeated for each orifice.

Orifice 1:

$$P_{d1} = 0$$

try $\beta_1 = 0.4, d_o = 27.52 \text{ mm}$
hence $K_1 = 97, [3]$
 $\Delta P_1 = 450 \text{ kPa (65.3 psi), equation 2}$
 $\sigma_1 = 0.214, \text{ equation 1}$
 $\sigma_{c1} = 0.9, [3]$

$$\sigma < \sigma_c \text{ unsatisfactory}$$

try $\beta_1 = 0.6, d_o = 41.3 \text{ mm}$
 $K_1 = 12$
 $\Delta P_1 = 55.7 \text{ kPa}$
 $\sigma_1 = 1.73$
 $\sigma_{c3} = 1.6$

$$\sigma > \sigma_c \text{ OK}$$

Orifice 2:

$$P_{d2} = P_{d1} + \Delta P_1$$
$$= 55.7 \text{ kPa}$$

try $\beta_2 = 0.5, d_o = 34.4 \text{ mm}$
 $K_1 = 30$
 $\Delta P_2 = 139 \text{ kPa}$
 $\sigma_2 = 1.09$
 $\sigma_{c2} = 1.15$

$$\sigma < \sigma_c \text{ unsatisfactory}$$

try $\beta_2 = 0.55, d_o = 37.8 \text{ mm}$
 $K_2 = 17.5$
 $\Delta P_2 = 811 \text{ kPa}$
 $\sigma_2 = 1.87$
 $\sigma_{c2} = 1.35$

$$\sigma > \sigma_c \text{ however try getting closer}$$

try $\beta_2 = 0.51, d_o = 35.1 \text{ mm}$
 $K_2 = 27$
 $\Delta P_2 = 125 \text{ kPa}$
 $\sigma_2 = 1.21$
 $\sigma_{c2} = 1.1$

$$\sigma > \sigma_c \text{ OK}$$

Orifice 3: try $\beta_3 = 0.45, d_o = 31.0 \text{ mm}$
 $P_{d3} = P_{d2} + \Delta P_3$
 $= 181 \text{ kPa}$
 $K_3 = 52$
 $\Delta P_3 = 241 \text{ kPa}$
 $\sigma_3 = 1.15$
 $\sigma_{c3} = 1.1$

$\sigma > \sigma_c$ OK

Orifice 4: try $\beta_4 = 0.4, d_o = 27.5 \text{ mm}$
 $P_{d4} = P_{d3} + \Delta P_4$
 $= 422 \text{ kPa}$
 $K_4 = 97$
 $\Delta P_4 = 450 \text{ kPa}$
gives $P_{d4} + \Delta P_4 = 873 \text{ kPa}$
however we need $P_{d4} + \Delta P_4 = 827 \text{ kPa}$, system upstream pressure

hence $\Delta P_4 = 405 \text{ kPa}$
from equation 2 $K_4 = \Delta P_4 / (1/2 \rho V^2) = 87$
gives $\beta_4 = 0.41, d_o = 28.2 \text{ mm}$
 $\sigma = 1.28$
 $\sigma_{c4} = 0.93$

$\sigma > \sigma_c$ OK

The above fixes the number of orifices required and the orifice diameter in each case. The next important design parameter is the plate spacing. For proper cavitation free operation the orifice plates must be spaced a certain axial distance from each other. This spacing is the axial distance, x downstream from each orifice necessary for complete pressure recovery [3]. An existing chart of β against the ratio x/R_p (where R_p is the pipe radius), can be used for this purpose [3]. This chart suggests:

$$x/R_p = 10.75 (1 - \beta)$$

$$x = 5.38 d (1 - \beta) \quad (8)$$

The final details of the multi orifice system are given in Table 5.

Table 5: Multi orifice system for Prairie air cooler circuit. Design to σ_c , "tolerable noise limit" [4]

Orifice No.	β	ΔP (kPa)	x (mm)	d_o (mm)
1	0.60	55.7	-	41.3
2	0.51	125	180	35.1
3	0.45	241	203	31.4
4	0.41	405	218	28.2
Total pressure drop		827 kPa		
Total length			601 mm	

2. Design to Incipient Cavitation Level

In this section of Appendix 3 a similar procedure is followed to that of section 1 of the Appendix. This time, however, a multiple orifice plate system is sized to the incipient level of cavitation, σ_i (no noise limit). As discussed in the main body of this paper σ_i is a highly conservative limit rarely used for design purposes. The purpose here is to investigate the practicality of such a system.

The terminology and plate numbering scheme is identical to that previously used. Once again the prairie air cooler circuit is used as an example. The flow and pipe data is as for the previous example. This time the method of reference [4] is used to determine σ_i . This is somewhat more involved than the determination of σ_c via reference [3], requiring adjustment for size scale effects. It may be more convenient to first determine σ_i for a range of β values, thus constructing a chart. For more extensive computation, the method of reference [4] lends itself well to automation on computer.

Orifice 1:
 $P_{d1} = 0$

try $\beta_1 = 0.65, d_o = 44.7 \text{ mm}$
hence $C_{d1} = 0.358, [4]$
 $K_1 = 6.8, \text{ equation 3}$
 $\Delta P_1 = 31.6 \text{ kPa}, \text{ equation 2}$
 $\sigma_1 = 3.05, \text{ equation 1}$
 $\sigma_{i1} = 3.13, [4]$

$\sigma < \sigma_i$ try again

try $\beta_1 = 0.66, d_o = 45.4 \text{ mm}$
 $C_{d1} = 0.374$
 $K_1 = 6.2$
 $\Delta P_1 = 28.6 \text{ kPa}$
 $\sigma_1 = 3.36$
 $\sigma_{i1} = 3.29$

$\sigma > \sigma_i$ OK

Orifice 2:
 $P_{d2} = P_{d1} + \Delta P_1$
 $= 28.6 \text{ kPa}$

try $\beta_2 = 0.6, d_o = 41.3 \text{ mm}$
 $C_{d2} = 0.287$
 $K_2 = 11.1$
 $\Delta P_2 = 51.6 \text{ kPa}$
 $\sigma_2 = 2.42$
 $\sigma_{i2} = 2.46$

$\sigma < \sigma_i$ try again

try $\beta_2 = 0.62, d_o = 42.7 \text{ mm}$
 $C_{d2} = 0.314$
 $K_2 = 9.1$
 $\Delta P_2 = 42.4 \text{ kPa}$
 $\sigma_2 = 2.95$
 $\sigma_{i2} = 2.71$

$\sigma > \sigma_i$ however try getting closer

try $\beta_2 = 0.61, d_o = 42.0 \text{ mm}$
 $C_{d2} = 0.301$
 $K_2 = 10.1$
 $\Delta P_2 = 46.8 \text{ kPa}$
 $\sigma_2 = 2.67$
 $\sigma_{i2} = 2.58$

$\sigma > \sigma_i$ OK

Orifice 3:

$$P_{d3} = P_{d2} + \Delta P_2$$

$$= 75.4 \text{ kPa}$$

try $\beta_3 = 0.55, d_o = 37.8 \text{ mm}$
 $C_{d3} = 0.228$
 $K_3 = 18.3$
 $\Delta P_3 = 84.8 \text{ kPa}$
 $\sigma_3 = 2.02$
 $\sigma_{i3} = 1.97$

$\sigma > \sigma_i$ OK

Orifice 4:

$$P_{d4} = P_{d3} + \Delta P_3$$

$$= 160 \text{ kPa}$$

try $\beta_4 = 0.40, d_o = 27.5 \text{ mm}$
 $C_{d4} = 0.106$
 $K_4 = 88.0$
 $\Delta P_4 = 408 \text{ kPa}$
 $\sigma_4 = 0.63$
 $\sigma_{i4} = 1.16$

$\sigma < \sigma_i$ unsatisfactory

try $\beta_4 = 0.50, d_o = 34.4 \text{ mm}$
 $C_{d4} = 0.179$
 $K_4 = 30.2$
 $\Delta P_4 = 140 \text{ kPa}$
 $\sigma_4 = 1.83$
 $\sigma_{i4} = 1.63$

$\sigma > \sigma_i$ however try getting closer

try $\beta_4 = 0.48, d_o = 33.0 \text{ mm}$
 $C_{d4} = 0.161$
 $K_4 = 37.6$
 $\Delta P_4 = 174.4 \text{ kPa}$
 $\sigma_4 = 1.47$
 $\sigma_{14} = 1.50$

$\sigma < \sigma_1$ unsatisfactory

try $\beta_4 = 0.49, d_o = 33.7 \text{ mm}$
 $C_{d4} = 0.170$
 $K_4 = 33.6$
 $\Delta P_4 = 155.8 \text{ kPa}$
 $\sigma_4 = 1.64$
 $\sigma_{14} = 1.57$

$\sigma > \sigma_1$ OK

Orifice 5:
 $P_{d5} = P_{d4} + \Delta P_4$
 $= 316 \text{ kPa}$

try $\beta_5 = 0.45, d_o = 31.0 \text{ mm}$
 $C_{d5} = 0.138$
 $K_5 = 51.3$
 $\Delta P_5 = 238 \text{ kPa}$
 $\sigma_5 = 1.67$
 $\sigma_{15} = 1.35$

$\sigma > \sigma_1$ however try getting closer

try $\beta_5 = 0.43, d_o = 29.6 \text{ mm}$
 $C_{d5} = 0.125$
 $K_5 = 63.5$
 $\Delta P_5 = 294 \text{ kPa}$
 $\sigma_5 = 1.35$
 $\sigma_{15} = 1.26$

$\sigma > \sigma_1$ OK

Orifice 6:
 $P_{d6} = P_{d5} + \Delta P_5$
 $= 611 \text{ kPa}$

try $\beta_6 = 0.38, d_o = 26.1 \text{ mm}$
 $C_{d6} = 0.095$
 $K_6 = 109$
 $\Delta P_6 = 506 \text{ kPa}$

gives $P_{d6} + \Delta P_6 = 1117 \text{ kPa}$

however we need $P_{d6} + \Delta P_6 = 827 \text{ kPa}$, system upstream pressure

hence we need $\Delta P_6 = 216 \text{ kPa}$

This is a smaller pressure drop than that at orifice 5, as such it must be a much smaller pressure drop than the maximum allowed by the cavitation criteria. Thus, the pressure drop at orifice 5 can be reduced, increasing the cavitation index there, σ_5 .

Revised Orifices 5 and 6:

These two orifices must provide a total pressure drop of:

$$\begin{aligned} \Delta P_5 + \Delta P_6 &= P_{\text{total}} - P_{d5} \\ &= 827 - 316 \text{ kPa} \\ &= 511 \text{ kPa} \end{aligned}$$

If we allow an equal pressure drop at each orifice:

$$\begin{aligned} \Delta P_5 + \Delta P_6 &= 511/2 = 256 \text{ kPa} \\ \text{from equation 2 } K_5 = K_6 &= \Delta P_5 / (1/2 \rho V^2) = 55.1 \\ \text{gives [3] } \beta_5 = \beta_6 &= 0.45, d_o = 31.0 \text{ mm} \end{aligned}$$

The number of orifices and the orifice diameters have been specified. It is now necessary to determine the plate spacings. This will be given by equation 8. The final details of the system are listed at Table 6.

Table 6: Multi orifice system for Prairie air cooler circuit. Design to σ_1 , "no noise limit" [4]

Orifice No.	β	ΔP (kPa)	x (mm)	d_o
1	0.66	28.6	-	45.4
2	0.61	46.8	145	42.0
3	0.55	84.8	168	37.8
4	0.49	156	188	33.7
5	0.45	256	203	31.0
6	0.45	256	203	31.0
total pressure drop		828 kPa		
total length			907 mm	

REPORT NO.
MRL-TN-637AR NO.
AR-008-260REPORT SECURITY CLASSIFICATION
Unclassified

TITLE

An analysis of cavitation activity at orifices of the FFG-7 seawater piping system

AUTHOR(S)
M. CastilloCORPORATE AUTHOR
DSTO Materials Research Laboratory
PO Box 50
Ascot Vale Victoria 3032REPORT DATE
March, 1993TASK NO.
NAV 89/037SPONSOR
RANFILE NO.
G6/4/8-4188REFERENCES
9PAGES
31

CLASSIFICATION/LIMITATION REVIEW DATE

CLASSIFICATION/RELEASE AUTHORITY
Chief, Ship Structures and Materials Division

SECONDARY DISTRIBUTION

Approved for public release

ANNOUNCEMENT

Announcement of this report is unlimited

KEYWORDS

Flow rates
Orifice plates
Orifice cavitationPressure
Pipe erosionCavitation
Ship noise

ABSTRACT

An analytical investigation has been made of cavitation in a number of pairs of orifice plates installed within the seawater cooling pipe lines of FFG-7 guided missile frigates. Four lines, where excessive noise and erosion have been reported, have been analysed; these are, the fire main recirculating line, the gas turbine start and bleed air cooler lines, and the prairie air cooler line. The results show that all circuits operate at exceedingly high levels of cavitation, much higher than the usual acceptable limit. The fire main line may suffer from supercavitation, possibly causing damage down stream from the second orifice. Sample design studies indicate that a simple multiple orifice plate arrangement may eliminate the problem.

An Analysis of Cavitation Activity at Orifices of the FFG-7 Seawater Piping System

M. Castillo

(MRL-TN-637)

DISTRIBUTION LIST

Director, MRL

Chief, Ship Structures and Materials Division

Dr J.C. Ritter

Mr M. Castillo

MRL Information Service

Chief Defence Scientist (for CDS, FASSP, ASSCM) (1 copy only)

Director, Surveillance Research Laboratory

Director (for Library), Aeronautical Research Laboratory

Director, Electronics Research Laboratory

Head, Information Centre, Defence Intelligence Organisation

OIC Technical Reports Centre, Defence Central Library

Officer in Charge, Document Exchange Centre (8 copies)

Army Scientific Adviser, Russell Offices

Air Force Scientific Adviser, Russell Offices

Navy Scientific Adviser, Russell Offices

Scientific Adviser, Defence Central

Director-General Force Development (Land)

Senior Librarian, Main Library DSTOS

Librarian, MRL Sydney - data sheet only

Librarian, H Block

UK/USA/CAN ABCA Armies Standardisation Rep. c/- DGAT (8 copies)

Librarian, Australian Defence Force Academy

Counsellor, Defence Science, Embassy of Australia - data sheet only

Counsellor, Defence Science, Australian High Commission - data sheet only

Scientific Adviser to DSTC, C/- Defence Adviser - data sheet only

Scientific Adviser to MRDC, C/- Defence Attache - data sheet only

Head of Staff, British Defence Research and Supply Staff (Australia)

NASA Senior Scientific Representative in Australia

INSPEC: Acquisitions Section Institution of Electrical Engineers

Head Librarian, Australian Nuclear Science and Technology Organisation

Senior Librarian, Hargrave Library, Monash University

Library - Exchange Desk, National Institute of Standards and Technology, US

Exchange Section, British Library Document Supply Centre

Periodicals Recording Section, Science Reference and Information Service, UK

Library, Chemical Abstracts Reference Service

Engineering Societies Library, US

Documents Librarian, The Center for Research Libraries, US

DGNER

DGNES

ANZAC PD

Aust. Frigate PD

Naval Support Command, Manager in Service Design, Naval Supply Command

PO Box 706, Darlinghurst NSW 2010

DNA, Campbell Park Offices CP1-5-05, Department of Defence, Canberra

DNN, Russell Offices A-3-21, Department of Defence, Canberra

AFPD, Campbell Park Offices CP2-1-16, Department of Defence, Canberra

FFG/DDG MOD PD, Campbell Park Offices, CP2-2-04A, Department of Defence, Canberra