



AASERT EVALUATION REPORT

Grant F49620-92-J-0358

Parent Award: AFOSR-91-0445

Parent award funding for 12-month period prior to AASERT award was \$298,866. The number of full-time graduate students supported by the agreement during this period was two.

Amount of funding for the parent award agreement for the 12-month period after the AASERT award was 294,089. The number of full-time equivalent graduate students during this period has been two.

The AASERT agreement provides \$137,315 for the three-year period of the award for the support of one graduate student, Kenji Matsuoka, who is named in the original proposal.

Mr. Matsuoka, a United States citizen and second year graduate student, was supported as a research assistant by the AASERT grant during all 12 months following the award. During this year he considerably advanced his knowledge of the field of single-electronics and made several important contributions to the project, especially in the development of dedicated software for characterization of single-electron systems. He will be a co-author of a publication which is in preparation and will be submitted to the Journal of Applied Physics by the end of Summer 1993. He also took part in the Santa Fe Institute Complex Systems Summer School.

His grades during this period were satisfactory (average A-minus).

DTIC
ELECTE
SEP 01 1993

This document has been approved
for public release and sale; its
distribution is unlimited.

REPORT DOCUMENTATION PAGE

OMB No. 0704-0188

Public reporting burden for this collection of information is estimated to average 1 hour per response, including the time for reviewing instructions, searching existing data sources, gathering and maintaining the data needed, and completing and reviewing the collection of information. Send comments regarding this burden estimate or any other aspect of this collection of information, including suggestions for reducing this burden, to Washington Headquarters Services, Directorate for Information Operations and Reports, 1215 Jefferson Davis Highway, Suite 1204, Arlington, VA 22202-4302, and to the Office of Management and Budget, Paperwork Reduction Project (0704-0188), Washington, DC 20503.

| | | | |
|--|--|--|--|
| 1. AGENCY USE ONLY (Leave blank) | | 2. REPORT DATE July 1993 | 3. REPORT TYPE AND DATES COVERED Annual Technical Report 7/1/92 - 6/30/93 |
| 4. TITLE AND SUBTITLE Tunneling Spectroscopy of Ultrasmall Clusters and Grains | | 5. FUNDING NUMBERS AFOSR F49620-92-J-0358 | |
| 6. AUTHOR(S) Dr. K. Likharev, Project Director | | | |
| 7. PERFORMING ORGANIZATION NAME(S) AND ADDRESS(ES) Research Foundation State University of New York Stony Brook, NY 11794-1001 | | 8. PERFORMING ORGANIZATION REPORT NUMBER | |
| 9. SPONSORING / MONITORING AGENCY NAME(S) AND ADDRESS(ES) Air Force Office of Scientific Research Electronic and Material Bolling AFB, DC 20332-6448 | | 10. SPONSORING / MONITORING AGENCY REPORT NUMBER 3484/S3 | |
| 11. SUPPLEMENTARY NOTES | | | |
| 12a. DISTRIBUTION / AVAILABILITY STATEMENT unlimited | | 12b. DISTRIBUTION CODE | |
| 13. ABSTRACT (Maximum 200 words) This report describes major results obtained during the first year of the three-year research project "Tunneling Spectroscopy of Ultrasmall Clusters and Grains." Topic covered: 1) New STM/S Concept, 2) Testing the Room Temperature Prototype, 3) Low-Temperature STM/S. | | | |
| 14. SUBJECT TERMS Scanning Tunneling Microscopy and Spectroscopy, Correlated Tunneling, Low Temperatures, Clusters, Grains, HOPG, Au C₆₀ | | 15. NUMBER OF PAGES 7 | |
| 17. SECURITY CLASSIFICATION OF REPORT unclassified | | 16. PRICE CODE | |
| 18. SECURITY CLASSIFICATION OF THIS PAGE unclassified | | 19. SECURITY CLASSIFICATION OF ABSTRACT | |
| 20. LIMITATION OF ABSTRACT | | | |

93-20318



81 03 8

(FY91 AASERT)

TUNNELING SPECTROSCOPY OF ULTRASMALL CLUSTERS AND GRAINS

AFOSR Grant # F49620-92-J-0358

Principal Investigator: Professor K. Likharev
Department of Physics
State University of New York
Stony Brook, NY 11794-3800

Project Period: July 1, 1992 - June 30, 1995

Report Period: July 1, 1992 - June 30, 1993

Research Objective:

To implement spectroscopy of ultrasmall conducting particles (metallic grains and clusters) with high spatial and energy resolution, using a dedicated scanning tunneling microscope/spectroscope (STM/S).

Report Period Objectives:

To create a reliable room-temperature scanning tunneling microscope/spectroscope with a new type of piezo-electric actuator, which could be readily redesigned for operation at low temperatures.

Collaboration:

Brookhaven National Laboratory
(Dr. M. Strongin, Dr. Z. Rong)

| | |
|--------------------|-------------------------------------|
| Accession For | |
| NTIS CRA&I | <input checked="" type="checkbox"/> |
| DTIC TAB | <input type="checkbox"/> |
| Unannounced | <input type="checkbox"/> |
| Justification | |
| By | |
| Distribution / | |
| Availability Codes | |
| Dist | Avail and/or Special |
| A-1 | |

DTIC SOURCE REPORT 1

MAJOR RESULTS

1. New STM/S Concept

Despite a broad proliferation of the scanning tunneling microscopy and spectroscopy, commercially available instruments do not allow convenient operation at low temperatures (which are necessary to achieve high energy resolution). The major problem is that virtually all these instruments use some sort of mechanical system for coarse adjustment of the scanning tip position ("coarse approach"), which is unacceptable for operation at very low temperatures (especially below ~ 1K). The major goal of this project is creation of the STM/S which would not require such a mechanical system, but have an electrical remote control.

As the first step, we have designed and fabricated a room temperature prototype of our planned instrument, which should be used to test its following features:

- 1) a new electrical remote control scheme of the coarse approach;
- 2) low vibration noise;
- 3) a compact body;
- 4) easy change of the tip and sample.

Figure 1 shows schematically our STM/S head which is 1.5 inches long with an outer diameter of 0.75 inches. The piezo-tube-scanner is glued onto a quartz rod which sits on four shear-motion piezo plates ("legs"). These plates are glued inside a 60 degree cutoff of the Macor body. The quartz rod is clamped from the top by a spring (BeCu) wire in a Teflon tubing. A substrate with a sample can be slid right from the front into its proper position under the two tungsten wire springs.

When voltage on all "legs" changes simultaneously, the scanner follows them, and it jumps back slightly when voltages on individual "legs" ramp back. The main point is that the forward movement exceeds backward jumps. Thus when a proper voltage sequence is applied to the piezo plates, the quartz rod can carry the STM/S scanner and tip to move along the cutoff to bring the tip to the tunneling distance with the sample.

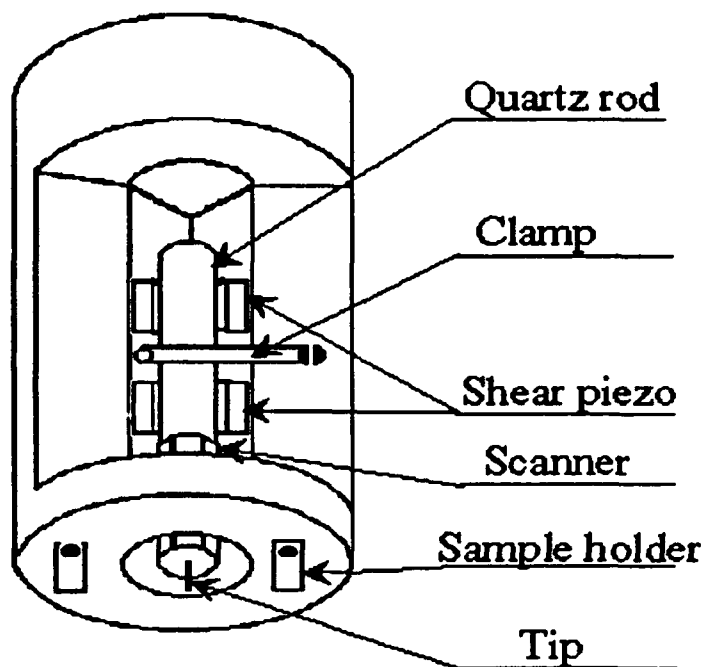

Figure 1.

The STM/S electronics (Fig. 2a) was purchased from RHK (Model STM/S 100). An additional high voltage board was added to provide up to eight high voltage outputs for the coarse adjustment. A Keithley current amplifier (Model 428 Revision G) was used for spectroscopy.

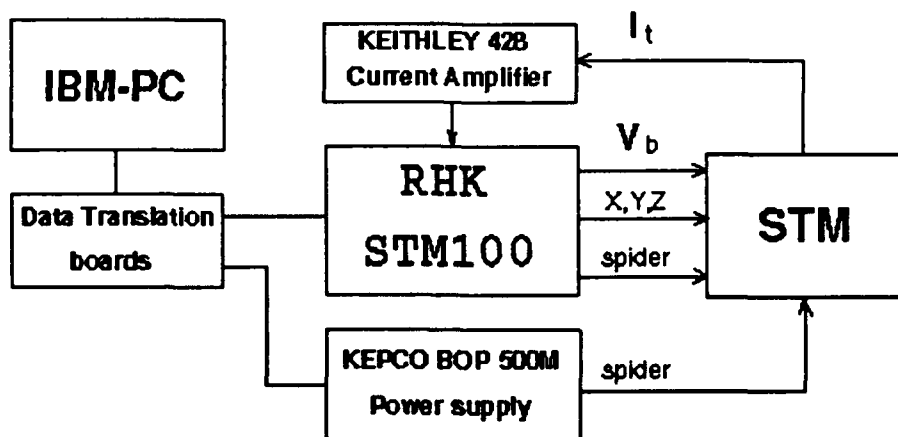

Figure 2.

2. Testing the Room Temperature Prototype

1) HOPG

We have found that our room temperature prototype allows us to obtain atomic spatial resolution on HOPG graphite samples without any vibration isolation. Figure 3 shows the hexagonal superstructure on graphite, with a period of 65.8Å, obtained in this way. Direct measurement of the angle between lattice-vectors has confirmed that the superstructure is a moiré pattern caused by a 2.1 degree rotation of the topmost (0001) plane with respect to the bulk. The STM/S corrugation of 2.6Å is not due to physical bulking, but to differences in electronic structure between AA-stacked, normal AB-stacked and rhombohedral ABC-stacked graphite. The high tunneling current of AA-stacked regions is in agreement with the high density of states at the Fermi level calculated for AA-graphite. The moiré pattern changes, both in the amplitude and shape, with the dc bias voltage. This observation provides a ground for a comparative study of surface electronic structures with different subsurface layer configuration, which is a vital test for our understanding of STM/S operation.

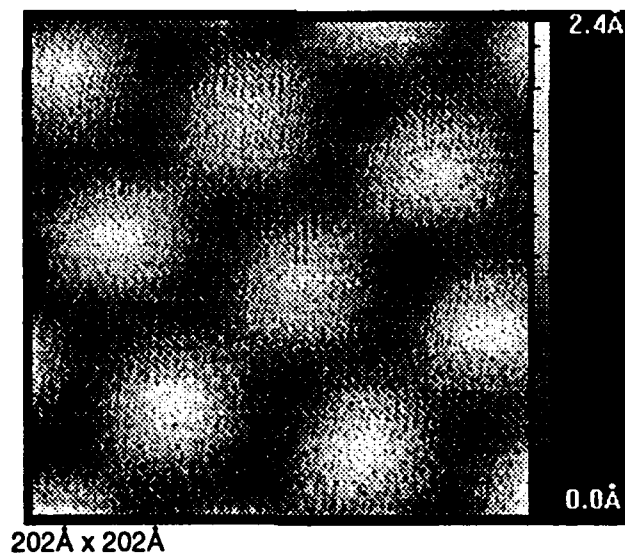

Figure 3.

Several other samples were explored as the potential candidates of substrate for supporting metal clusters.

2) Au(111)

Gold films were deposited on green mica substrate which were baked at 440° C for 18 hours at pressure $3 \cdot 10^{-7}$ torr. 1500Å of gold was evaporated with the speed 1.5Å/s in a vacuum better than $8 \cdot 10^{-7}$ torr at the sample temperature 440° C. After annealing at the same temperature for 1 hour, samples were slowly cooled down to the room temperature (it took 2 hours).

Our experiments have shown that these films have atomically flat regions ~0.1 μm wide. Figure 4 shows an unfiltered STM image of such a region. One can see a hexagonal lattice of 2.9Å in periodicity and 0.1Å z-corrugation. The measured value for the interatomic spacing together and the absence of corrugation lines has allowed us to conclude that what we see is a metastable, unreconstructed Au(111) surface.

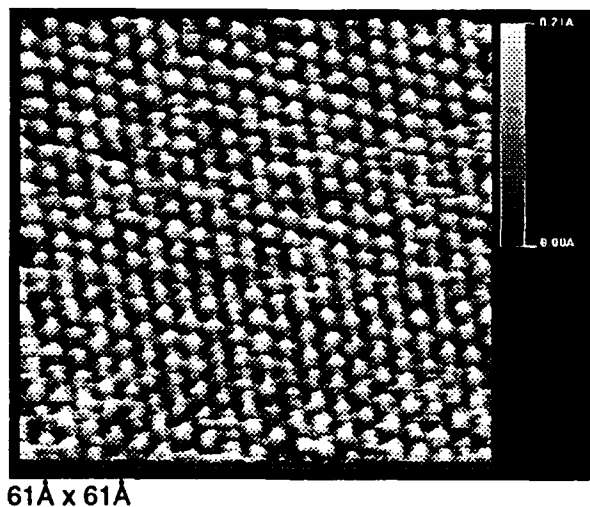
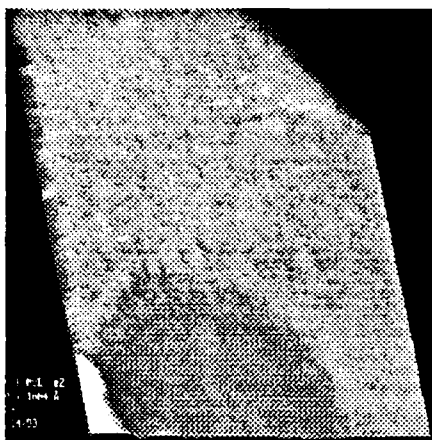

Figure 4.

3) C₆₀

On the top of some of Au films described above, 1.7 M.L. of C₆₀ was added by evaporating C₆₀ powder (90%C₆₀/10%C₇₀) at 500°C with a speed between 0.1 and 0.6Å/s.



1000Å x 1000Å

Figure 5.

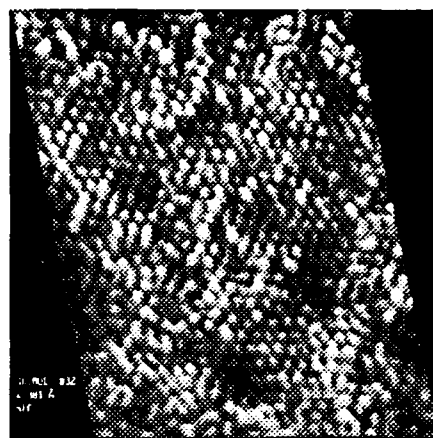

300Å x 300Å

Figure 6.

Figure 5 shows an STM image of C_{60} on Au(111) substrate. The circular hole has a depth of 8\AA which matches the expected value for a (111) step on bulk FCC C_{60} . We were able to identify the higher flat region as the second atomic layer of C_{60} , and the region inside the hole as the first layer which contacts the Au(111) substrate directly. The relative area is consistent with the 1.7 M.L. coverage. On both layers, we were able to observe hexagonal arrays of intermolecular spacing of 10\AA with tip biasing well below HOMO-LUMO gap voltage. Figure 6 is an example of $300\text{\AA} \times 300\text{\AA}$ scan on the first layer at 124mV tip biasing. The brighter spots are speculated to be C_{70} .

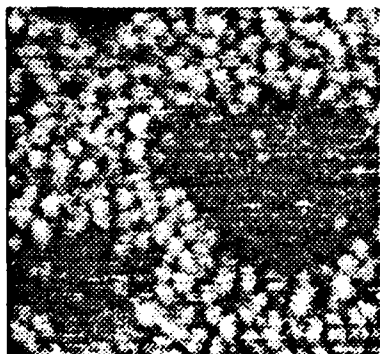

1500Å x 1500Å

Figure 7.

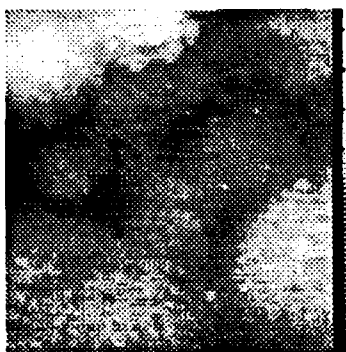

300Å x 300Å

Figure 8.

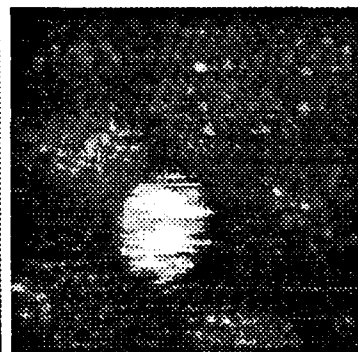

300Å x 300Å

Figure 9.

It was interesting and important for us to explore overlayer growth of a metal on such a C_{60} film, that may reveal the nature of the metal-fullerene interface (Au clustering on top of the C_{60} bulk has been observed earlier by photoelectron spectroscopy). We vapor deposited 2\AA of Au on the C_{60} film with an evaporation speed of $0.1\text{\AA}/s$.

To our surprise, the morphology of the film changed enormously (Fig. 7) after adding the Au overlayer. Comparing this image with one shown in Fig. 5, we can see that the first C_{60} layer remains flat, while the second C_{60} layer becomes a granular structure with an average grain size of 80\AA in a quasi-close-packed array. A closer look (Fig. 8) shows that these are C_{60} grains with an average corrugation of 3\AA . Au clusters could also be seen to sit both on top of the regular C_{60} structure (Fig. 9), and on top of the C_{60} grains. In fact, the roughening of the initial C_{60} surface could be expected due to the strong interaction between Au- C_{60} (chemisorption), but details of such a change, to the best of our knowledge, were revealed for the first time in our study.

3. Low Temperature STM/S

We have started to redesign our scanning head for low-temperature operation. In order to compensate the drop of piezoelectric response at low temperatures, we have replaced the single shear piezo plates with 3-layer shear piezo stacks. Three KEPCO bipolar 500V power supplies (Kepco BOP 500M) were used to drive these stacks. The low temperature STM/S head was suspended on four cotton strings inside a copper can (1.5 inch in O.D.) with Indium O-ring seal, which could be inserted directly into the neck of a standard helium storage Dewar. Preliminary vacuuming was performed through a $3/4$ inch I.D. stainless steel tubing pumping line. Temperature is controlled by an Omega controller (Model CYC91), with a Si-diode sensor and a resistive heater mounted on the STM/S head.

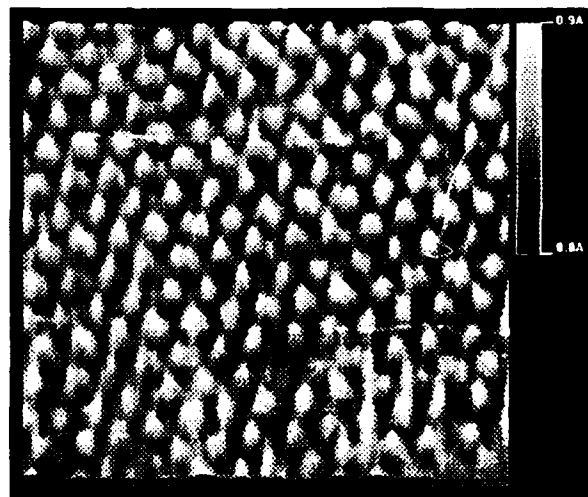

31Å x 31Å

Figure 10.

We have successfully operated the low temperature STM/S at both -77 K and -4 K . For example, Figure 9 is an atomic-resolution image of graphite at 5.1 K . However, more work on this design should be carried out to make operation the low temperature STM/S completely reliable. This work is in currently in progress.