

AD-A268 918



NAWCWPNS TP 8062

2  
HJ

# DESCRIPTION OF THE FIVE STEEL CUBE LAUNCHER USED IN THE MULTIPLE FRAGMENT IMPACT TEST

**S** DTIC  
ELECTE  
SEP 01 1993  
**A** **D**

by

Frank E. Norris

*Ordnance Systems Department*

JUNE 1993

NAVAL AIR WARFARE CENTER WEAPONS DIVISION  
CHINA LAKE, CA 93555-6001



Approved for Public Release; Distribution is  
Unlimited.

03 8 31 109

93-20389



# Naval Air Warfare Center Weapons Division

## FOREWORD

This report summarizes the work undertaken to transition the MIL-STD-2105A Multiple Fragment Impact test from 25 cube fragments to 5 cube fragments. The work and tests to achieve this transition were conducted by the Naval Weapons Center (NWC) (now known as the Naval Air Warfare Center Weapons Division (NAWCWPNS), China Lake) between 1989 and 1991. The work was executed within the Ordnance Systems Department (C27) while the author was a member of the Department. This effort was funded through the NAWCWPNS Insensitive Munitions Office (Code C27B) by the Naval Air Systems Command (AIR-540TF) under AIRTASK A932932K/008C/W0592000.

This report was reviewed for technical accuracy by Martha Wagenhals.

Approved by  
D. A. GOSS, *Head*  
*Ordnance Systems Department*  
30 June 1993

Under authority of  
W. E. NEWMAN  
RAdm., U.S. Navy  
*Commander*

Released for publication by  
S. HAALAND  
*Deputy Commander for Research & Development*

## NAWCWPNS Technical Publication 8062

Published by ..... Technical Information Department  
Collation ..... Cover, 23 leaves  
First printing ..... 325 copies

# REPORT DOCUMENTATION PAGE

Form Approved  
OMB No. 0704-0188

Public reporting burden for this collection of information is estimated to average 1 hour per response, including the time for reviewing instructions, searching existing data sources, gathering and maintaining the data needed, and completing and reviewing the collection of information. Send comments regarding the burden estimate or any other aspect of this collection of information, including suggestions for reducing this burden, to Washington Headquarters Services, Directorate for Information Operations and Reports, 1215 Jefferson Davis Highway, Suite 1204, Arlington, VA 22202-4302, and to the Office of Management and Budget, Paperwork Reduction Project (704-0188), Washington, DC 20503.

1. AGENCY USE ONLY (Leave blank)		2. REPORT DATE June 1993	3. REPORT TYPE AND DATES COVERED Summary	
4. TITLE AND SUBTITLE DESCRIPTION OF THE FIVE STEEL CUBE LAUNCHER USED IN THE MULTIPLE FRAGMENT IMPACT TEST			5. FUNDING NUMBERS Air Task A932932K/008C/W0592000	
6. AUTHOR(S) Frank E. Norris				
7. PERFORMING ORGANIZATION NAME(S) AND ADDRESS(ES) Naval Air Warfare Center Weapons Division China Lake, CA 93555-6001			8. PERFORMING ORGANIZATION REPORT NUMBER NAWCWPNS-TP 8062	
8. SPONSORING/MONITORING AGENCY NAME(S) AND ADDRESS(ES) Naval Air Systems Command Washington, D.C. 20361			10. SPONSORING/MONITORING AGENCY REPORT NUMBER	
11. SUPPLEMENTARY NOTES				
12a. DISTRIBUTION/AVAILABILITY STATEMENT A statement; distribution is unlimited.			12b. DISTRIBUTION CODE	
13. ABSTRACT (Maximum 200 words)  MIL-STD-2105A provides a framework for the development of a consolidated explosives safety and IM assessment test program for non-nuclear munitions. The test recommended by these directives to simulate fragment impact is derived from the Explosives Advanced Development (EAD) Program's multiple fragment impact test. The EAD test uses single-point initiated Composition B explosive (~200 pounds) to launch 25 1/2-inch mild steel cubes, having an initial velocity of 8300 ft/s, at a target placed 17 feet from the projector charge. At least three of these fragments are required to impact an 8-inch-diameter generic warhead.  When this procedure was used during testing at the Naval Air Warfare Center Weapons Division (formerly Naval Weapons Center), China Lake, difficulties were encountered in reliably hitting smaller targets (more representative of air-to-air missiles). This was because of the relatively large spread of the fragments at the 17-foot standoff location of the targets. A series of tests was conducted to determine the important variables in the fragment impact test in hope of more accurately controlling fragment velocity, aimability, pattern dispersal, and test-to-test repeatability. The report summarizes the results of those tests and describes the development and implementation of a 5-cube fragment projector.				
14. SUBJECT TERMS Multiple Fragment Impact, Fragment Launcher, FRAGMAT, 25-Cube Projector, 9-Cube Projector, 5-Cube Projector, Composition B, Fragment Impact, Insensitive Munitions Testing, Test Setup, Instrumentation			15. NUMBER OF PAGES 44	
			16. PRICE CODE	
17. SECURITY CLASSIFICATION OF REPORT UNCLASSIFIED	18. SECURITY CLASSIFICATION OF THIS PAGE UNCLASSIFIED	19. SECURITY CLASSIFICATION OF ABSTRACT UNCLASSIFIED	20. LIMITATION OF ABSTRACT SAR	

**UNCLASSIFIED**

**SECURITY CLASSIFICATION OF THIS PAGE (When Data Entered)**

[Empty rectangular box for security classification data]

CONTENTS

Introduction..... 3

Background ..... 3

Approach..... 5

Multiple Fragment Impact Test..... 10

    Test Item..... 10

    Fragment Projector Fabrication..... 10

    Explosive Projector Fabrication ..... 10

    FRAGMAT and Explosive Projector Assembly ..... 11

    Fragment Velocity..... 11

    Instrumentation..... 11

    Test Setup ..... 13

    Pretest Data Requirements..... 14

    Post-Test Data Requirements..... 14

Velocity Calculation..... 20

    High Speed Film Method..... 20

    Velocity Screen Method..... 20

References..... 21

Nomenclature ..... 22

Appendixes:

    A. Explosive Projector Manufacturing Procedures..... 23

        Fabrication Materials ..... 23

        Explosive Mold Construction..... 24

        Explosive Preparation ..... 26

        Casting and Cool-Down Procedures ..... 27

    B. Assembly of Multiple Fragment Projectors (Modified for Five Cubes Only)..... 29

        Fragment Confinement Frame ..... 29

        Assembly of Fragment Projector End Pieces..... 33

        Selecting Charge Size, Weight..... 36

        Explosive Charge Remote Cutting ..... 37

        Explosive Projector Charge Assembly..... 39

<input checked="" type="checkbox"/>
<input type="checkbox"/>
<input type="checkbox"/>

DTIC QUALITY INSPECTED 1

Availability Codes	
Dist	Avail and/or Special
A-1	

NAWCWPNS TP 8062

Figures:

1. Typical Multiple Fragment Impact Test Setup.....	4
2. Twenty-Five-Cube Fragment Impact Pattern.....	5
3. Nine-Cube Fragment Confinement Frame.....	6
4. Nine-Cube Fragment Impact Pattern.....	7
5. Five-Cube Fragment Confinement Frame.....	8
6. Five-Cube Fragment Impact Pattern.....	9
7. Test Site Instrumentation Setup.....	12
8. Side View of Test Setup.....	13
9. Pretest Data Recording Forms.....	15
10. Post-Test Data Recording Forms.....	17
11. Polar Debris Map.....	19
B-1. Confinement Frame Side Pieces.....	30
B-2. Assembled Confinement Frame.....	31
B-3. Five-Cube Fragment Configuration.....	32
B-4. Assembled Fragment Projector Forward End Piece.....	34
B-5. Fragment Projector Aft End Piece.....	35
B-6. Explosive Projector Charge Box.....	38
B-7. Assembled Projector Charge Box.....	40
B-8. Photograph of Assembled Projector Charge Box Showing Composition 4 Booster and RP-83 Detonators in Position for Firing.....	41

Tables:

B-1. Fragment Velocity Versus Explosive Charge Length (Approximate).....	36
--	----

ACKNOWLEDGMENTS

This task would not have been accomplished without the positive efforts of the personnel in a lot of areas. The Explosive Processing Branch was responsible for casting the Composition B explosive, and producing quality charges when needed. The Area "R" personnel made every effort to assist in suggesting ways to enhance the success of the overall test, and providing data needed to document the validity of the changes to the test. They made every effort possible to keep the schedule on time. John Fontenot allowed wide latitude in setting a schedule for the completion of this task and documentation, at the same time identifying problem areas and suggesting possible corrections. To all who participated, the author expresses his sincere thanks.

## INTRODUCTION

This report summarizes the effort to define and improve the Multiple Fragment Impact test as described in References 1 and 2. In December 1988, J. L. Stotser (Ordnance Systems Department) at the Naval Air Warfare Center Weapons Division (NAWCWPNS) (formerly Naval Weapons Center (NWC)), China Lake, California, published NWC TM 6411 (Reference 3). This document set the standards at NAWCWPNS for conducting the Multiple Fragment Impact test. From July 1989 to June 1991, an extensive effort was conducted to define and test methods to improve the aim point accuracy and dispersion of the 1/2-inch steel cubes, decrease the number of the 1/2-inch steel cubes from 25 to some lesser number, and, possibly, find an alternate explosive to replace the Composition B used as the fragment propelling charge. This effort was concluded with the adoption of a five-cube fragment projector, which is very accurate, yet controls the number of fragment impacts on a test item to allow a better appraisal of the test item reaction to the multiple fragment impact stimuli. Procedures for preparing the explosive charge and assembling the fragment projector are presented in Appendixes A and B, respectively.

The effort to replace the Composition B was not pursued due to the cost of a replacement explosive and the apparent characteristic of Composition B which permits the cube fragments to lead the detonation products cloud and, thus, enables a photograph record to be made and used for cube velocity determination. The conduct of the Multiple Fragment Impact test was very well defined in NWC TM 6411, and no effort was made to make changes to the setup or general layout of the test.

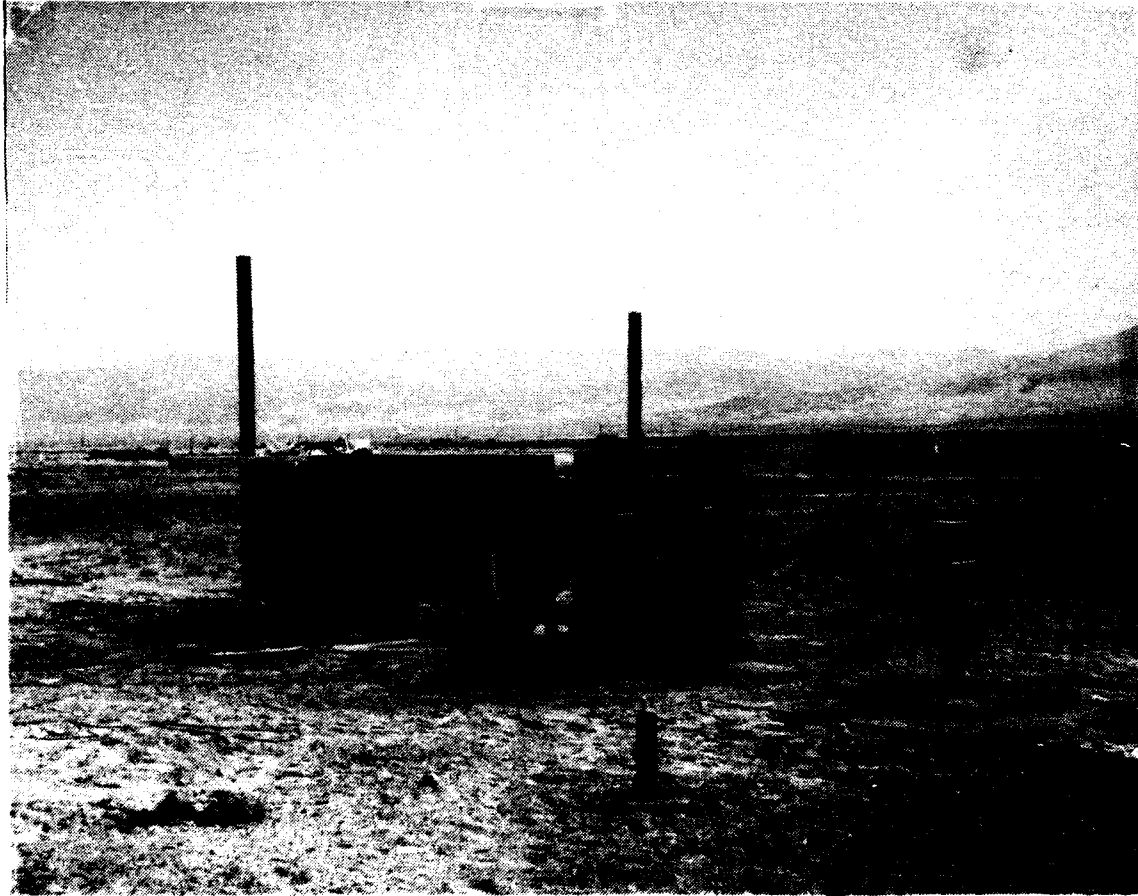
## BACKGROUND

The Multiple Fragment Impact test is one of the required hazard assessment tests for non-nuclear munitions defined in MIL-STD-2105A (Reference 4). MIL-STD-2105A establishes the general requirements for the conduct of the test and pass/fail criteria, but does not describe the specifics on constructing a fragment launcher. This document describes specifics involved in conducting such a test, including detailed directions for fabricating the fragment projector and all associated hardware and instrumentation, test site setup, and munition configuration. Figure 1 provides a photographic overview of a typical Multiple Fragment Impact test site.

The primary objective of the Multiple Fragment Impact test is to determine the reaction of a test item containing an energetic material when impacted by multiple 250-grain, 1/2 × 1/2-inch mild steel cubes at a required velocity of 8300 ft/s ± 300 ft/s. During tests using twenty-five 250-grain mild steel cubes, the impact pattern at 17 feet is generally 14 × 14 inches, as depicted in Figure 2. This means that the test item is hit with up to 25 mild steel cubes, depending upon the diameter of the test item. With this extreme amount of energy transfer to the test item/energetic material, the reaction of the test item/energetic material was difficult to assess accurately. The test, as originally developed under the Explosives Advanced Development Program, was intended to achieve an impact of 2 to 5 cubes on an 8-inch-diameter cylinder at the 17-foot standoff distance, but this was never specified in a document. Subsequent refinements of the test and fragment projector resulted in a significant increase in the number of fragments impacting the

NAWCWPNS TP 8062

test item. An analysis of the fragment impact test (Reference 5) presented the difference in response of a test item when impacted by 2 to 5 fragments and when impacted by 10 or more fragments. This paper was presented to the Insensitive Munitions community and resulted in the incorporation of the 2 to 5 fragment impact requirement in the revision of MIL-STD-2105A, (NAVY) dated 8 March 1991 (Reference 4).



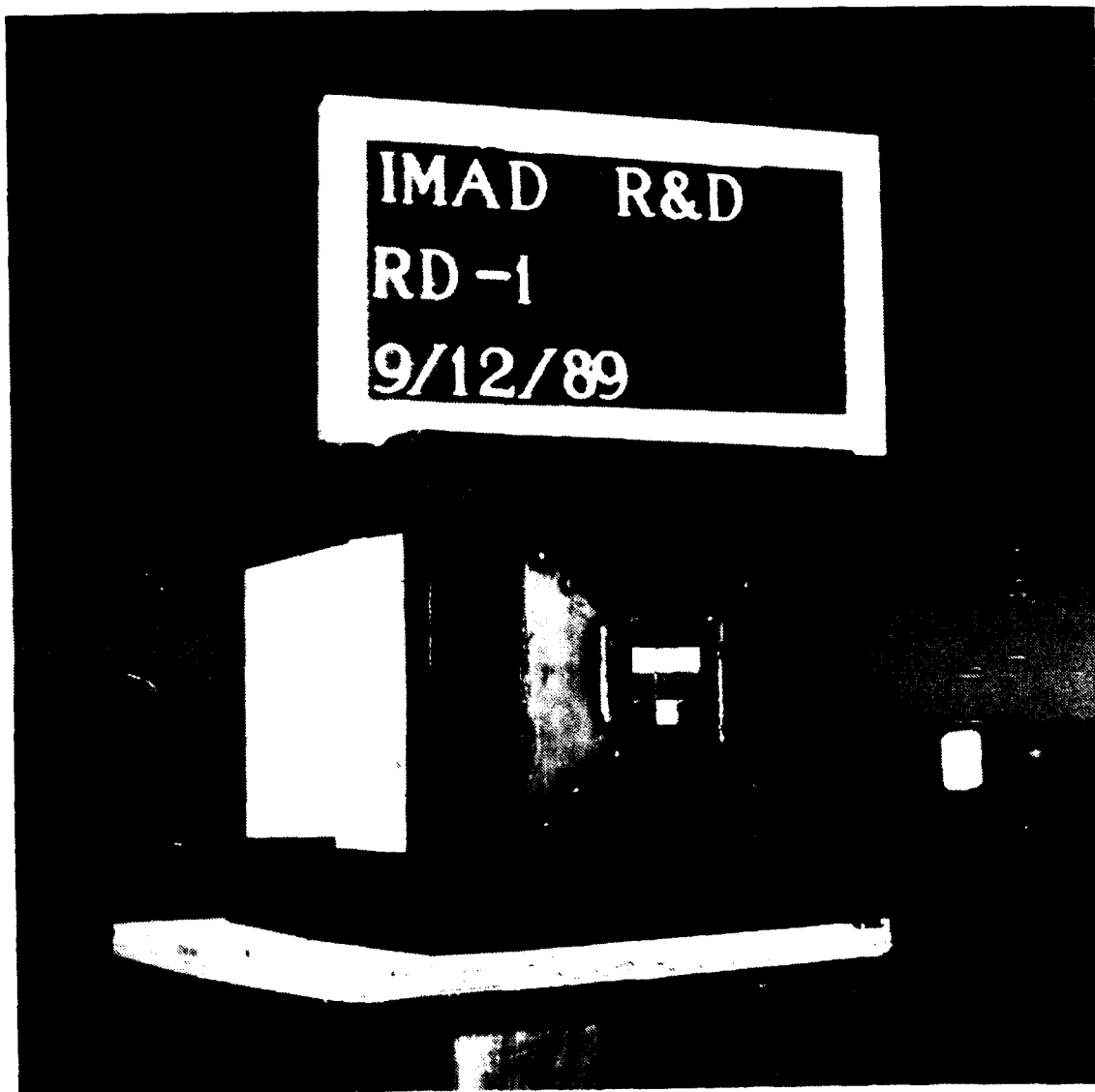
**FIGURE 1. Typical Multiple Fragment Impact Test Setup.**



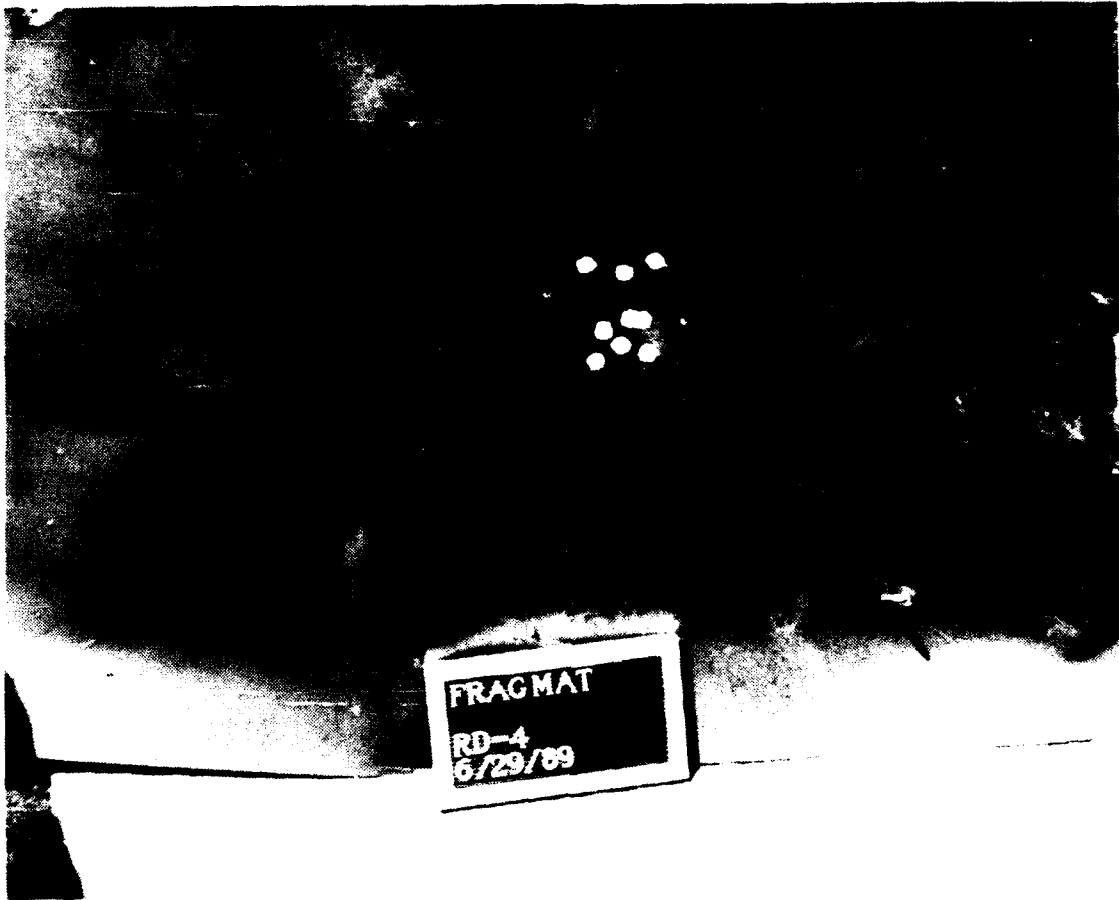
**FIGURE 2. Twenty-Five-Cube Fragment Impact Pattern.**

### **APPROACH**

The first task was to find a way to ensure the test item was impacted with fewer steel cubes, yet yield a response that would closely emulate a real world scenario. This led to the use of 9 mild steel cubes (Figure 3) in a modified steel fragment projector. Ten tests were conducted with this configuration. The impact pattern was measured at 6 x 6 inches (Figure 4). All parameters remained controlled and repeatable. However, the average number of fragment impacts for larger diameter test items (8 inches and greater) was 9, still considered an excessive amount of energy imparted to the test item.

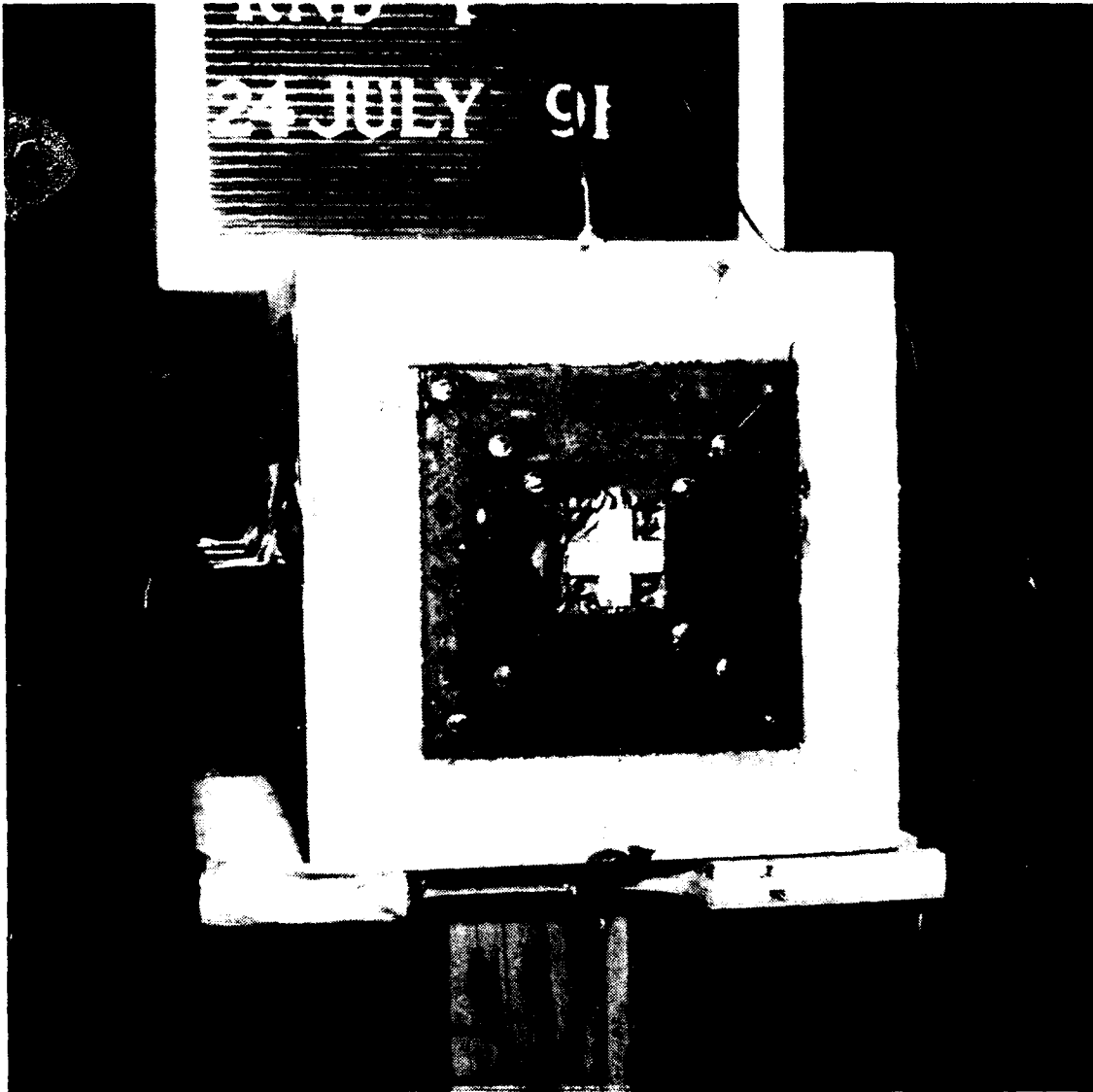


**FIGURE 3. Nine-Cube Fragment Confinement Frame.**



**FIGURE 4. Nine-Cube Fragment Impact Pattern.**

Therefore, a 5-cube array was tested. Five mild steel cubes were installed in a modified frame in a cross pattern (Figure 5), and three tests were conducted. The results met expectations, with the impact pattern being spread in a cross pattern on the vertical witness plate with a side-to-side measurement of 6 inches (three cubes evenly spaced horizontally) and with a top-to-bottom measurement of 6 inches (three cubes evenly spaced vertically), as shown in Figure 6. At present, this is the only fragment projector used at NAWCWPNS for the Multiple Fragment Impact test.



**FIGURE 5. Five-Cube Fragment Confinement Frame.**



**FIGURE 6. Five-Cube Fragment Impact Pattern.**

## MULTIPLE FRAGMENT IMPACT TEST

### TEST ITEM

The test item used in the Multiple Fragment Impact test should represent as closely as possible the configuration of the munition that will be released for production/Fleet issue. The test item should be fully assembled with all energetic components and subcomponents (i.e., igniter, safe/arm device, fuze, etc.). All components of the test item should be identified by Mk, Mod, S/N, etc., with a listing of energetic material and explosive weight for future reference.

### FRAGMENT PROJECTOR FABRICATION

The fragment projector (FRAGMAT) will be of the closed or non-spaced type and should not contain any type of gas check, as shown in Figure 5. The FRAGMAT is made from mild steel with the dimensions as shown in Appendix B. The FRAGMAT will contain only five 1/2-inch, 250-grain mild steel cubes. The dimensions of the FRAGMAT frame have been changed to allow the use of only five 1/2-inch steel cubes instead of the original number of twenty-five 1/2-inch steel cubes. The five-degree angle has been retained, as this has proven to be the most effective method for deflecting the frame side plates away from the test item at the 17-foot standoff distance used for this test.

The five-degree angle of the FRAGMAT, which results in the concave shape, is incorporated to cause the FRAGMAT frame pieces to diverge from the boresight line during flight. As the detonation wave travels through the projector explosive, the angle of incidence on the frame pieces sets up the off-axis vector, while retaining an on-axis vector for the flight of the cube fragments, since they lie in a plane normal to the detonation wave. The stripper plate/blast barrier intercepts the diverging frame fragments, preventing them from impacting the test item. The fragment cubes pass through the opening in the stripper plate/blast barrier. The stripper plate/blast barrier also prevents the detonation products and blast wave from the projector charge from interacting with the test item, allowing the response of the test item to be a function of the fragment impact alone.

### EXPLOSIVE PROJECTOR FABRICATION

The explosive projector can be assembled as shown in Appendix A. The material used to make the projector box is 0.750-inch-thick (3/4 inch) plywood or pressboard. At present, the NAWCWPNS explosive projectors are being made with 3/4-inch-thick pressboard. When the explosive containers have been fabricated and are ready for casting of the Composition B, the containers must be insulated as described in Appendix A, and all steps should be followed to ensure the best results from the Composition B (i.e., to prevent excessive cracking or separation within the cast explosive).

## FRAGMAT AND EXPLOSIVE PROJECTOR ASSEMBLY

When assembling the FRAGMAT to the explosive projector, follow the procedures in Appendix B. There are no special concerns or needs other than to follow all safety rules concerning explosives. The epoxy resin used is a 5-minute type, which sets in a very short time and can be used at the firing site, if preferred. Five predrilled holes will be in the rear of the explosive projector for the five RP-83 detonators and the Composition 4 or N-5 pellet boosters to be inserted at the test site during final preparations for firing.

## FRAGMENT VELOCITY

The required velocity of the fragment cubes for this test is 8300 ft/s  $\pm$ 300 ft/s. A practical method for verifying that the desired velocity is achieved is to conduct at least one calibration test using just a witness plate, two velocity screens, and a high speed camera. See Figure 7 for a diagram of the instrumentation setup. The recommended explosive projector dimensions of 8 x 8 inches, with a length of 10.5 inches, has consistently yielded a nominal velocity of 8200-8500 ft/s. The velocity screens have occasionally been triggered by small particles and are, consequently, less reliable than the high speed cameras in determining fragment velocity. The camera used for this test is a 1/4 frame at 16,000 frames/s. Also shown in Figure 7 is an optional rear oblique high speed camera to aid in determining fragment velocity by viewing the fragment cubes exiting the rear of the witness plate.

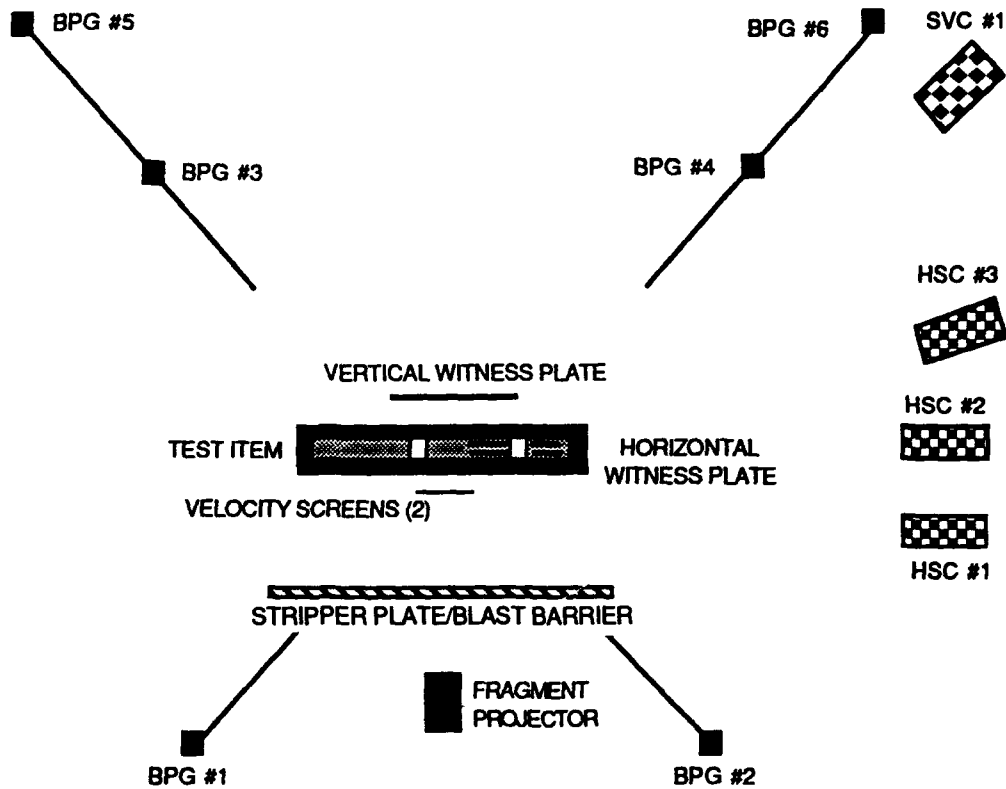
## INSTRUMENTATION

### Cameras and Pressure Gages

The instrumentation required for the Multiple Fragment Impact test consists of three high speed cameras (8000, 16,000, and 32,000 frames/s), and at least one video camera for overall viewing, with the option of a shuttered video camera for an overall side view. The video camera used is a standard color video camera mounted at a high point overlooking the test area to give an overall view of the test. As an option, a shuttered video camera is used and mounted on either the right or left side of the test behind a camera blast shield; this camera also yields an overall view of the test. Another option shown in Figure 7 is an overpressure gage array.

### Velocity Screens

NAWCWPNS uses commonly available commercial manufacture velocity screens. The screens are made of a copper grid inlaid on a medium weight paper. The grid is laid in such a way that each side is separated by a 1/16-inch open area. When the impacting cubes hit the copper grid, an electric circuit is completed, allowing a signal to trigger an electrical recording device (i.e., oscilloscope, electronic tracing machine, etc.). The screens do not appear to be susceptible to false activation, and have been used with a high degree of confidence.



ITEM	INSTRUMENTATION TYPE/PURPOSE	SPECIAL REMARKS
<b>Required Instrumentation &amp; FOV</b>		
HSC #1	High speed camera (32,000 fps)-velocity	1-ft. behind impact point to 1-ft. behind fragment projector (~20 ft.)
HSC #2	High speed camera (8,000 fps)-impact/exit point	36 in. forward & behind test item (~80 in.)
HSC #3	High speed camera (16,000 fps)-exit point/velocity	2-ft. behind vertical witness plate to 2-ft. behind fragment projector (~24 ft.)
SVC #1	Video camera-overall test site	>50 ft radius of test site
<b>Optional Instrumentation</b>		
BPG #1	Overpressure gage-blast pressure	45-degree, left & front of test item (24 feet)
BPG #2	Overpressure gage-blast pressure	45-degree, right & front of test item (24 feet)
BPG #3	Overpressure gage-blast pressure	45-degree, left & back of test item (40 feet)
BPG #4	Overpressure gage-blast pressure	45-degree, right & back of test item (40 feet)
BPG #5	Overpressure gage-blast pressure	45-degree, left & back of test item (60 feet)
BPG #6	Overpressure gage-blast pressure	45-degree, right & back of test item (60 feet)

FIGURE 7. Test Site Instrumentation Setup.

## TEST SETUP

It is recommended that the test engineer or his representative be present during the test setup. This will enable the test facility personnel to respond to the standard test requirements or any special test requirements in a timely manner. Figure 8 shows a side view schematic of the test setup.

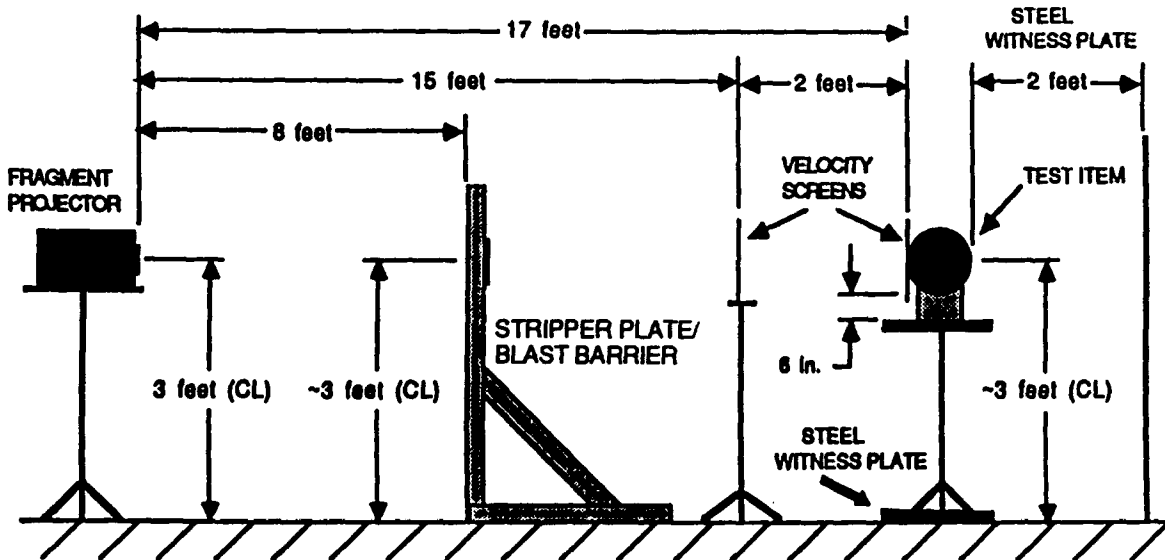


FIGURE 8. Side View of Test Setup.

An assembled explosive fragment projector box, fabricated per Appendixes A and B, is placed on a wooden stand with the centerline of the charge 36 inches above ground level and the face of the fragment projector 17 feet from the test item. In the interests of safety, it may be necessary to restrain the test item to prevent it from endangering any nearby personnel or structures in the event it becomes propulsive. The method of restraint should approximate as closely as possible the method used to attach the test item to an aircraft or launcher/bomb rack.

A steel witness plate 1/2 inch thick and slightly larger than the test item is placed on the ground directly under the test item to aid in the test item reaction assessment. Directly behind, at a 2-foot distance from the test item, a vertical steel witness plate (4 feet  $\times$  8 feet  $\times$  1/16 inch in thickness) is set. This vertical witness plate will help to determine the number of 1/2-inch cube impacts the test item sustained and will possibly show any test item fragments.

The early Multiple Fragment Impact tests used a 22-gauge steel witness plate (with a 10-inch opening cut in the center) in front of the test item. There was no attempt to stop the side plates of the fragment confinement frame, or to try and deflect the blast debris cloud from obscuring the test item. A major refinement to the fragment impact test was to place the witness plate behind the test item, and place a stripper plate/blast barrier in front of the test item. The witness plate was a 4-  $\times$  8-foot piece of 16-gauge steel suspended so that the center of the plate was 36 inches above ground level, on the same centerline as

the multiple fragment projector and test item. This allowed a method for better recording the fragments hit/miss ratio, and to see the fragmentation of the test item.

The stripper plate/blast barrier is manufactured using 3-inch-thick armor plate, and large mild steel I-beams to reinforce the upright plate. The vertical face of the stripper plate/blast barrier is 8- × 8-ft<sup>2</sup> welded to a base plate 8 feet wide × 6 feet long. This is further reinforced with 12-inch I-beams welded to form a triangular structure between the base plate and the vertical armor plate. Two 6-inch I-beams per side can be used in place of the single 12-inch I-beams. Figure 1 shows the stripper plate/blast barrier constructed using 12-inch I-beam bracing.

For alignment purposes, a section of 1-inch angle iron, 17 feet in length, is used for the setup. The section of angle iron is placed between the test item and the FRAGMAT, on three wooden stands, and leveled using a carpenter's level. Once the angle iron is level, ensure that the end toward the test item is just touching the test item at the chosen point of impact. At the fragment projector end, ensure that the angle iron is just touching the center fragment cube. By sighting down the length of the explosive charge, in line with the angle iron, the point of impact of the fragment cubes can be determined or adjusted to assure that the fragments impact the test item at the chosen point of impact. Optionally, the fragment projector assembly can be equipped with an optical or laser sighting device.

Once the alignment is satisfactory, the angle iron is removed, and the velocity screens are put in place. The start velocity screen is placed 2 feet in front of the test item, and the stop velocity screen is taped to the test item at the point of impact. Installed distance between the velocity screens must be accurately measured, as every 1/10 inch introduces a velocity error of about 35 ft/s at these velocities. Once the velocity screens are in place, an overall check of the test site should be made to ensure everything is ready for the test to proceed.

## **PRETEST DATA REQUIREMENTS**

To ensure the test site has been prepared per the test request procedure, a final inspection of the area is recommended. This inspection should be conducted by the firing officer and the requesting test engineer or his representative. During this inspection, the location of the test hardware, the high speed cameras, video cameras, and the blast pressure gauges are verified. All pretest photographs of the test item and overall test setup should be taken at this time. The following atmospheric conditions should be recorded: air temperature, wind velocity and direction, humidity, and barometric pressure, as required. The forms used at NAWCWPNS are represented in Figures 9 and 10.

## **POST-TEST DATA REQUIREMENTS**

As a minimum, the following data are recommended: (1) blast pressure data, if available, will be plotted on 8.5- × 11-inch paper in engineering units; (2) post-test color, 8- × 10-inch (one set minimum) photographs of the test site, close-up views of individual and grouped test items, and individual and grouped test item debris, with a ruler placed adjacent to the debris to show relative size of the object; and (3) black and white, 5- × 7-inch photographs (screened) for reproduction uses and color 8- × 10-inch transparencies (viewgraphs, viewfoils) produced from the color negatives. The original video film will be given to the test engineer, along with the original high speed film. Post-test data of the debris should be recorded on a polar debris map such as the one shown in Figure 11, with the location, weight, and distance from the test site of all significant test item debris.

**MULTIPLE FRAGMENT IMPACT  
DATA SHEET**

**I. PRETEST**

TO BE COMPLETED BY TEST FACILITY ENGINEER

Test No. \_\_\_\_\_ Date/Time: \_\_\_\_\_

Test Facility Engineer: \_\_\_\_\_

Technicians: \_\_\_\_\_

Firing Officer: \_\_\_\_\_

Photographer: \_\_\_\_\_ Camera Operator: \_\_\_\_\_

Fragment Projector S/N: \_\_\_\_\_

Explosive Charge Type: \_\_\_\_\_

Explosive Charge Box Length (L): \_\_\_\_\_ in.

Charge Box Weight (Wt): \_\_\_\_\_ lbs. Explosive Weight (We): \_\_\_\_\_ lbs

Booster Charge Type: \_\_\_\_\_

Explosive Charge Detonators: \_\_\_\_\_

Air Temperature: \_\_\_\_\_ °F Barometric Pressure: \_\_\_\_\_

Wind Velocity: \_\_\_\_\_ Wind Direction: \_\_\_\_\_

Humidity: \_\_\_\_\_

Camera No.: \_\_\_\_\_ Camera Type: \_\_\_\_\_ Film Speed: \_\_\_\_\_

Distance & Location from Test Item: \_\_\_\_\_

Camera No.: \_\_\_\_\_ Camera Type: \_\_\_\_\_ Film Speed: \_\_\_\_\_

Distance & Location from Test Item: \_\_\_\_\_

Camera No.: \_\_\_\_\_ Camera Type: \_\_\_\_\_ Film Speed: \_\_\_\_\_

Distance & Location from Test Item: \_\_\_\_\_

Camera No.: \_\_\_\_\_ Camera Type: \_\_\_\_\_ Film Speed: \_\_\_\_\_

Distance & Location from Test Item: \_\_\_\_\_

**FIGURE 9. Pretest Data Recording Forms.**

**MULTIPLE FRAGMENT IMPACT  
DATA SHEET**

**I. PRETEST (continued)**

TO BE COMPLETED BY REQUESTING CODE ENGINEER

Requesting Code Test Engineer: \_\_\_\_\_

Requesting Code Engr. Technician(s): \_\_\_\_\_  
\_\_\_\_\_

Energetic Components/Subcomponents: \_\_\_\_\_  
\_\_\_\_\_  
\_\_\_\_\_

Test Item S/N: \_\_\_\_\_

Distance (FRAGMAT to "Stripper" Barrier): \_\_\_\_\_ ft.

Distance (FRAGMAT to Test Item): \_\_\_\_\_ ft.

Distance (Test Item to Horizontal Metal Witness Plate): \_\_\_\_\_ in.

Distance (Test Item to Vertical Metal Witness Plate): \_\_\_\_\_ in.

Distance (FRAGMAT to Start Velocity Screen): \_\_\_\_\_ in.

Distance (FRAGMAT to Stop Velocity Screen): \_\_\_\_\_ in.

Peak Air Blast Overpressure Gages: (YES / NO) circle one

Deviations from the test plan: \_\_\_\_\_  
\_\_\_\_\_  
\_\_\_\_\_  
\_\_\_\_\_

Deviations Approved by: \_\_\_\_\_ Date: \_\_\_\_\_

**FIGURE 9. Continued.**

**MULTIPLE FRAGMENT IMPACT  
DATA SHEET**

**II. POST TEST**

TO BE COMPLETED BY TEST FACILITY ENGINEER

Significant Test Events: \_\_\_\_\_

\_\_\_\_\_  
\_\_\_\_\_  
\_\_\_\_\_

Test Site Inspection: \_\_\_\_\_

\_\_\_\_\_  
\_\_\_\_\_  
\_\_\_\_\_

Condition of the Horizontal Witness Plate: \_\_\_\_\_

\_\_\_\_\_  
\_\_\_\_\_

No. of Known Fragment Cube Impacts (Vertical Witness Plate): \_\_\_\_\_

No. of Known Fragment Cube Impacts (Test Item): \_\_\_\_\_

How was fragment count determined? \_\_\_\_\_

\_\_\_\_\_

Total Weight of Test Item Fragments: \_\_\_\_\_ lbs.

General Condition of the Test Site: \_\_\_\_\_

\_\_\_\_\_  
\_\_\_\_\_  
\_\_\_\_\_

**FIGURE 10. Post-Test Data Recording Forms.**

**MULTIPLE FRAGMENT IMPACT  
DATA SHEET**

**III. DATA ANALYSIS**

TO BE COMPLETED BY TEST FACILITY ENGINEER

Peak Air Blast Overpressure (OPTIONAL):

Gage No.:	_____	Measured Value:	_____ psi
Gage No.:	_____	Measured Value:	_____ psi
Gage No.:	_____	Measured Value:	_____ psi
Gage No.:	_____	Measured Value:	_____ psi
Gage No.:	_____	Measured Value:	_____ psi
Gage No.:	_____	Measured Value:	_____ psi

TO BE COMPLETED BY THE CAMERA OPERATOR

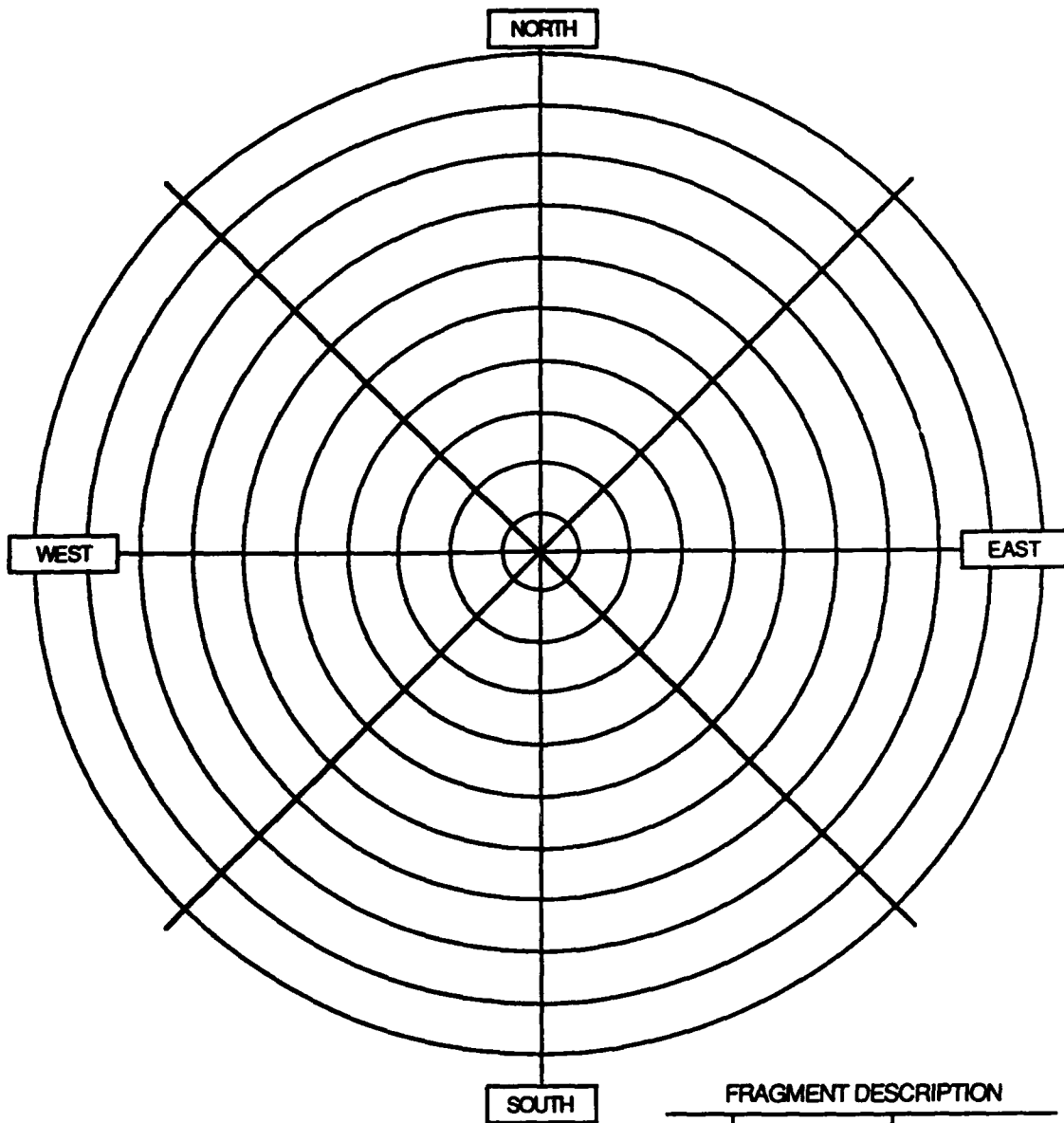
High Speed Film Documentation:

Camera No.:	_____	Film Speed Obtained:	_____
Camera No.:	_____	Film Speed Obtained:	_____
Camera No.:	_____	Film Speed Obtained:	_____

Average Velocity Calculated: \_\_\_\_\_ fps

Method Used to Calculate Average Velocity: \_\_\_\_\_

**FIGURE 10. Continued.**



NOTE: Circles represent 25 foot increments unless otherwise noted.

FRAGMENT DESCRIPTION		
No.	Size	Weight
1		
2		
3		
4		
5		
6		
7		
8		
9		

FIGURE 11. Polar Debris Map.

## VELOCITY CALCULATION

### HIGH SPEED FILM METHOD

The actual film speed from the high speed cameras must be determined by counting the number of frames between two "timing marks" (red dots) at the same location on the film. The "stop" point frame (impact of the test item by the fragment cubes) is determined by visual observation of the high speed film. Initiation of the firing line is taken to be the "raw start" time or time zero. The total number of frames between test initiation (zero time) and the "stop" point frame is then determined. The "raw" flight time is calculated by dividing the total number of frames by the actual film speed (frames divided by frames per second). The actual flight time is determined by subtracting the time for the detonators to function and for the detonation wave to transit the explosive charge (approximately 34 microseconds for a 10.5-inch-long explosive charge) from the "raw" flight time. With the flight distance (17 feet) and the actual flight time of the fragment cubes known, the average velocity can be determined (distance divided by actual time).

### VELOCITY SCREEN METHOD

The time recorded on the electronic timer for the fragment cubes to travel the distance between the two velocity screens has, in past tests, resulted in slightly lower calculated velocities than noted using the high speed film method. The error results from "unidentified" lightweight material outrunning the fragment cubes and causing early activation of the "start screen."

In addition to measuring the time for the fragments to travel the 2-foot separation distance between the velocity screens, the time for the fragments to reach the start screen (15 feet) and the time for the fragments to reach the stop screen (17 feet) can be measured.

The average velocity over 2 feet, over 15 feet, and over 17 feet will be calculated by the following methods, unless the high speed film reveals that early activation of the start screen by unidentified materials has occurred. If early activation has occurred, then only the average velocity calculated over the 17 feet should be considered valid.

$$\bar{V}_{15'} = \frac{15 \text{ feet}}{(T_{15'} - \text{Initiation time})} \quad \bar{V}_{17'} = \frac{17 \text{ feet}}{(T_{17'} - \text{Initiation time})}$$

$$\bar{V}_{2'} = \frac{2 \text{ feet}}{(T_{17'} - T_{15'})}$$

Where:

$\bar{V}_{17'}$  = average velocity over 17 feet

$\bar{V}_{15'}$  = average velocity over 15 feet

$\bar{V}_2$  = average velocity over 2 feet

$T_{17}$  = time for fragments to travel 17 feet

$T_{15}$  = time for fragments to travel 15 feet

Initiation time = time for the explosive charge detonators to function and the detonation wave to transit the length of a 10-inch explosive charge (34 microseconds).

### REFERENCES

1. Naval Surface Weapons Center. *Explosives Advanced Development Program -- Large-Scale Safety, Vulnerability, and Performance Test Procedures*, by W. D. Smith and W. D. Houchins. Dahlgren, VA, NSWC, May 1983. (NSWC TR 83-53, publication UNCLASSIFIED.)
2. Naval Weapons Center. *Preliminary Investigation of the Multiple Fragment Impact Test* by J. W. Farmer and L. M. Davis. China Lake, CA, NWC, February 1988. (NWC TM 6129, publication UNCLASSIFIED.)
3. Naval Weapons Center. *Standard Procedures for Conducting the Multiple Fragment Impact (FRAGMAT) Test ("For Score")*, by J. L. Stotser. China Lake, CA, NWC, December 1988. (NWC TM 6411, publication UNCLASSIFIED.)
4. Department of Defense. "Hazard Assessment Tests for Non-Nuclear Munitions," 8 March 1991, MIL-STD-2105A (NAVY).
5. John S. Fontenot. "Analysis of U.S. Navy Fragment Impact Test," presented at the 1990 Tri-Service Symposium on Explosives Testing, 21-22 March 1990.

**NOMENCLATURE**

BPG	Blast Pressure Gage
C-4	Composition 4 Explosive
CL	Centerline
FRAGMAT	Fragment Projector
HSC	High Speed Camera
MIL-STD	Military Standard
Mk	Mark Number
Mod	Modification Number
N-5	PBXN-5 booster explosive in pellet form
NAWCWPNS	Naval Air Warfare Center Weapons Division (formerly NWC), China Lake
No.	Number
NSWC	Naval Surface Warfare Center (formerly Naval Surface Weapons Center)
NWC	Naval Weapons Center, China Lake
S/N	Serial Number
SVC	Site Video Camera
TM	Technical Memorandum, a NAWCWPNS type of publication
TR	Technical Report, a NSWC official publication
We	Weight of Explosive
Wt	Weight, Weight of charge box
deg	degrees
°F	degrees Fahrenheit
ft/s	feet per second
frames/s	frames per second
ft	feet
in	inch, inches
L	Length
lb/in	pound per inch
lbs	pounds
psi	pounds per square inch

**Appendix A**  
**EXPLOSIVE PROJECTOR MANUFACTURING PROCEDURES**

**FABRICATION MATERIALS**

The following materials are required to fabricate the explosive projector:

- a. 0.75-inch-thick exterior plywood or pressboard
- b. RTV silicone rubber adhesive sealant, MIL-A-46106A, Type 1, white (suitable substitute may be used)
- c. Fast-curing epoxy binder (two-part mix)
- d. Silicone grease (suitable gasket sealer)
- e. Chempak sheet insulation (suitable substitute may be used)
- f. Small nails (1.5 inches long)
- g. Carriage bolts with nuts (long enough to bolt riser to top of 36-inch box for casting)
- h. Water jacketed riser (300- to 350-in<sup>3</sup> volume)
- i. Jacketed, anchor bladed stirrer melt kettle (or similar type)
- j. Grade A (nominal 5-second viscosity) Composition B, 145 pounds (Grade B Composition B may be used).

## **EXPLOSIVE MOLD CONSTRUCTION**

### **Side Pieces**

1. Using 0.75-inch-thick plywood or pressboard, cut two pieces 9.5 inches wide × 36 inches long and two pieces 8 inches wide × 36 inches long.
2. Apply an ample amount of silicone rubber sealer to the side edges of the two 8-inch-wide plywood/pressboard pieces.
3. Secure the two 9.5-inch-wide plywood/pressboard pieces to the 8-inch-wide pieces with nails. The internal dimensions of the plywood/pressboard mold should be 8 inches square.
4. Apply silicone rubber sealant, as necessary, to any cracks in the plywood/pressboard mold to prevent leakage. The TNT in the molten Composition B explosive is very fluid, and tends to find even the smallest cracks in the box.
5. Determine the weight of the plywood/pressboard mold. This measurement provides weight per unit length of the box mold (lb/in).

### **End Pieces**

1. Cut a 9.5-inch-square piece of plywood/pressboard to be used as a mold top.
2. Drill a hole through the center of the mold top the same diameter as the inside diameter of the riser.
3. Place riser on the mold top over the drilled hole, mark and drill holes through the mold top corresponding to the holes in the riser base flange.
4. Apply an ample amount of silicone rubber sealer to the top side of the mold top, surrounding the riser hole.
5. Place the riser on the mold over the silicone rubber sealer.
6. Apply silicone grease to the bottom of the riser base flange. Secure the riser to the mold top with carriage bolts. When bolting the riser to the mold top, bolts must protrude out the top of the mold. The nuts should rest on the riser base flange.
7. Wrap tape around the nuts and protruding bolts to reduce the possibility of being coated with melted explosive during the casting operation.
8. Cut a 9.5-inch-square piece of plywood/pressboard to be used as the mold bottom.
9. Apply ample amount of silicone rubber sealer to the edges of one end of the plywood/pressboard box mold. Position the bottom mold piece in place and secure to the mold box with nails.
10. Apply ample amount of silicone rubber sealer to the open end of the mold box. Position the top mold piece in place and secure to mold with nails.
11. Cut three pieces of Chempak (sheet insulation may be used), 12 inches wide by 40 inches long, to insulate the top of the mold box and the bottom of the riser. Starting at the top of the mold box, wrap one piece of insulation around the circumference of the mold and secure the insulation to the mold with staples or tape. Apply the second piece of insulation to the mold in the same manner as described above, but start 6 inches below the top of the mold box. This will result in a 6-inch overlap of the bottom portion of the first piece of insulation. Apply the third piece of insulation in the same manner, but abutting the top of the second piece of insulation. The third piece of insulation overlaps the top half of the first piece, and covers the top of the mold and the lower section of the riser. Ensure that the insulation is wrapped around the top of the mold box and the water jacket riser. Also ensure that the bottom 18 inches of the mold box are not insulated.

### EXPLOSIVE PREPARATION

1. Grade A (nominal 5-second viscosity) Composition B explosive is recommended. Grade B is an acceptable substitution for the Grade A, but is noticeably more viscous.
2. Place the Composition B in a suitable jacketed anchor bladed stirrer melt kettle and heat the explosive at a temperature of 185 to 195°F until completely melted.

**Observe all pertinent explosive operating procedures.**

3. After the Composition B explosive has completely melted, apply 25 inches Hg vacuum to the kettle for a period of 10 minutes, and continue agitation.
4. The Composition B is now ready for casting.

### NOTE

Since Composition B shrinks as it cools, it is necessary to manage the cool-down period to prevent shrinkage cracking and separation within the charge mass. The technique recommended to manage the cool-down period in the mold requires using heated risers and layers of insulation. The method behind managing the cool-down period is to cool the mold from the bottom-up.

### CASTING AND COOL-DOWN PROCEDURES

1. A water temperature of 195°F is recommended for circulation through the riser.
2. Fill the box mold and riser with molten Composition B.
3. The level in the riser will drop as the mold cools. As the level of molten Composition B drops in the riser, refill the riser with additional molten Composition B. It is extremely important to keep an ample amount of molten explosive in the riser to fill the voids created by the shrinkage as the explosive cools in the box mold. To avoid having to constantly top off the riser, the riser should have a capacity of 13 to 15% of the mold volume (300- to 350-in<sup>3</sup> volume).
4. After 2 to 3 hours, remove the bottom layer of insulation. Top off the riser with molten explosive and allow to cool overnight, approximately 16 hours.
5. When the initial cool-down period has been completed (approximately 16 hours), turn off the hot water to the riser and remove the remaining two layers of insulation. Ensure that a small amount of molten explosive remains in the riser, since the level of the mold will drop as the top of the mold cools to ambient temperature.
6. After the riser has cooled, remove the tape from the protruding nuts and bolts. Inspect the threads of the bolts for any evidence of explosive material, and remove all explosive material in an approved manner, before removing the nuts from the protruding bolts.
7. Upon completion of riser removal, identify the explosive loaded mold boxes with appropriate S/N, casting date, and type of explosive.
8. The use of X-ray on the explosive loaded mold boxes is an option that can show voids or other problems within the explosive mass. The X-rays can be used to select the cutting lines to ensure the quality of the projector charges.

**Appendix B**  
**ASSEMBLY OF MULTIPLE FRAGMENT PROJECTORS**  
**(MODIFIED FOR FIVE CUBES ONLY)**

**FRAGMENT CONFINEMENT FRAME**

The original fragment confinement frame was produced following the procedures contained in NSWC TR 83-53 (Reference 1 of main report), and are included in this document for practical purposes. This confinement frame, as used at China Lake, did not contain a gas check, and one is not recommended. The dimensions of the frame have been changed so only five 1/2-inch-square, 250-grain fragment cubes can be used.

**Required Materials**

- a. 0.5 × 0.5 × 0.5 inch mild steel cubes (5 per frame)
- b. 0.5-inch-thick mild steel plate
- c. Fast-curing epoxy binder (two-part mix)
- d. Adhesive Cyanoacrylate (super glue) MIL-A-46050C, Type II, Class 2.

**Confinement Frame Fabrication**

1. Fabricate the confinement frame side plates from 1/2-inch-thick mild steel stock as per Figure B-1.
2. Assemble the confinement frame by spot welding the frame side plates (4 each required) together, as shown in Figure B-2.
3. Clean confinement frame and steel cubes with acetone or suitable cleaner to remove residue.
4. Assemble the five steel cubes in the required configuration (Figure B-3) applying the adhesive Cyanoacrylate to the mating surfaces of each cube. The bottom face of the cube matrix must be flush against a flat underlying surface.
5. Place the confinement frame on a flat nonporous surface. The confinement frame should be positioned with the concave surface facing upward.
6. Place the five assembled fragment cubes in the opening in the confinement frame. The bottom face of the cube matrix should be flush against the underlying nonporous surface.
7. Prepare the fast-curing epoxy binder in accordance with the manufacture's instructions. Spread the epoxy mixture over the exposed surface of the steel cube matrix and the edges of the confinement frame. Ensure the corner holes are filled to the surface evenly. Allow the epoxy binder to cure completely before moving the assembled fragment confinement frame.

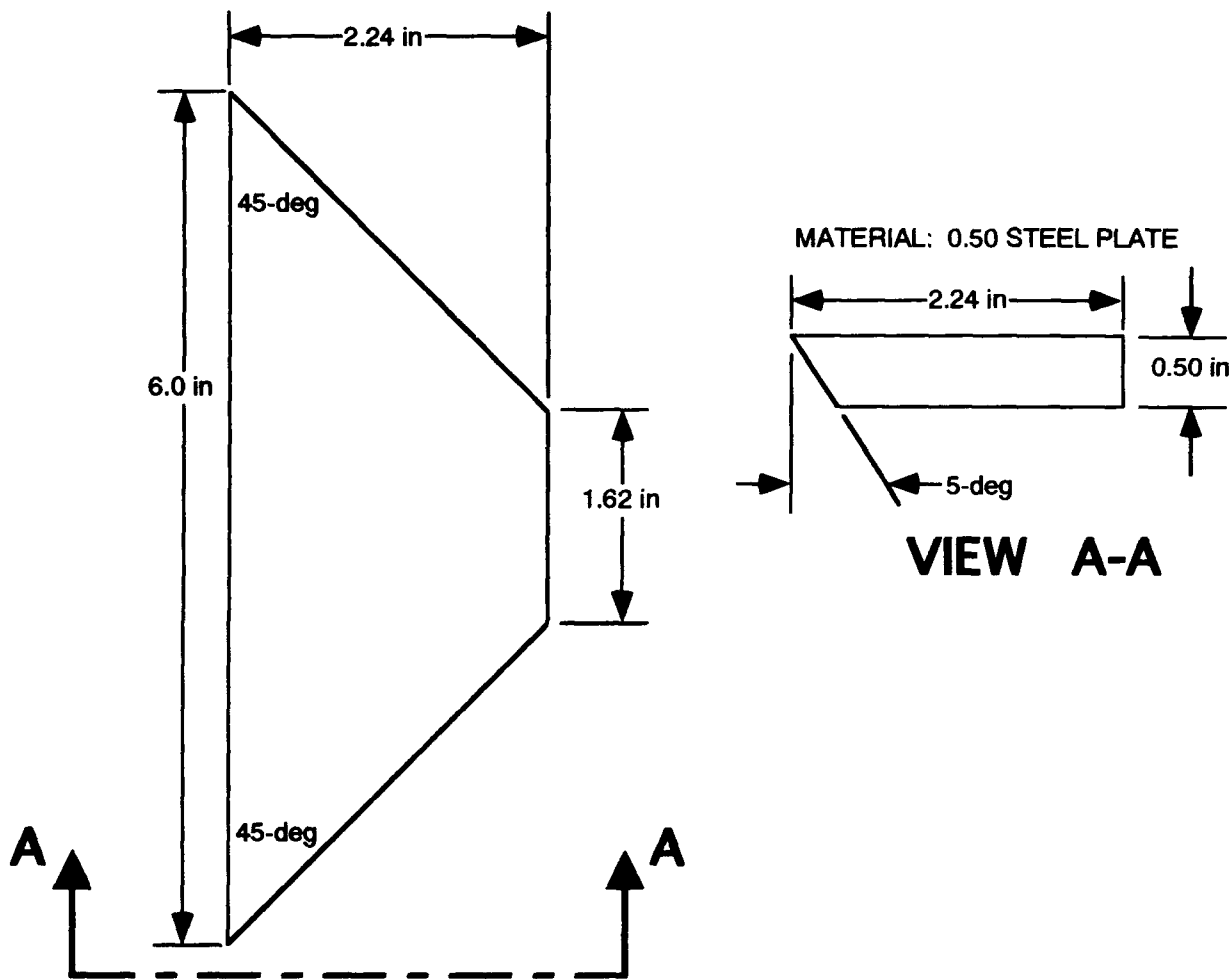


FIGURE B-1. Confinement Frame Side Pieces.

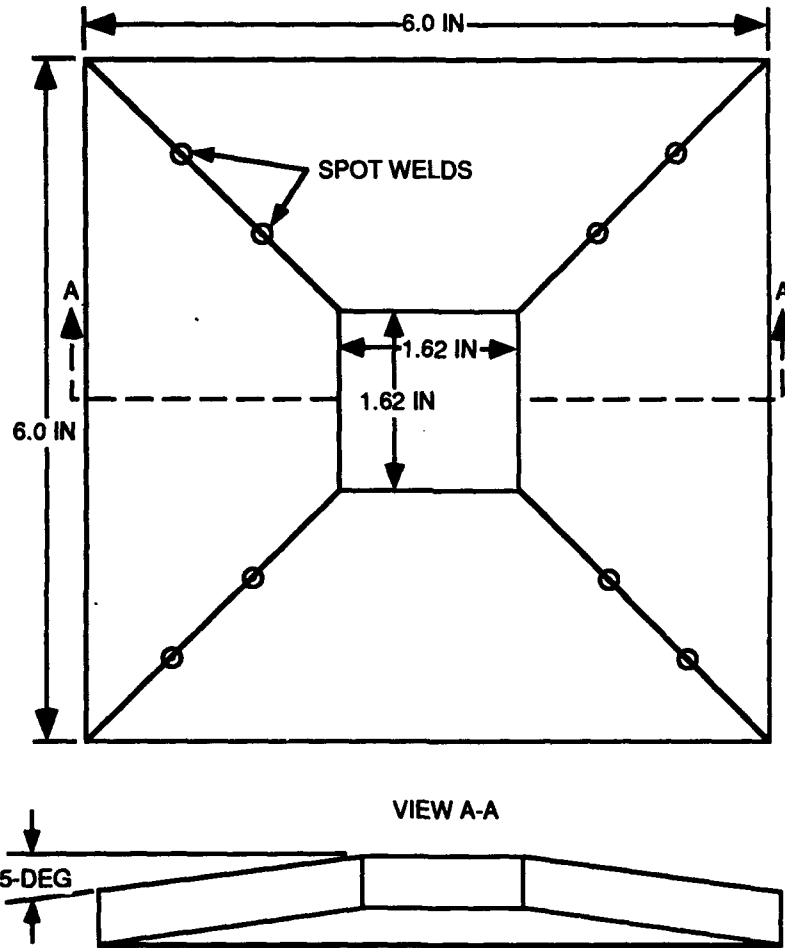


FIGURE B-2. Assembled Confinement Frame.

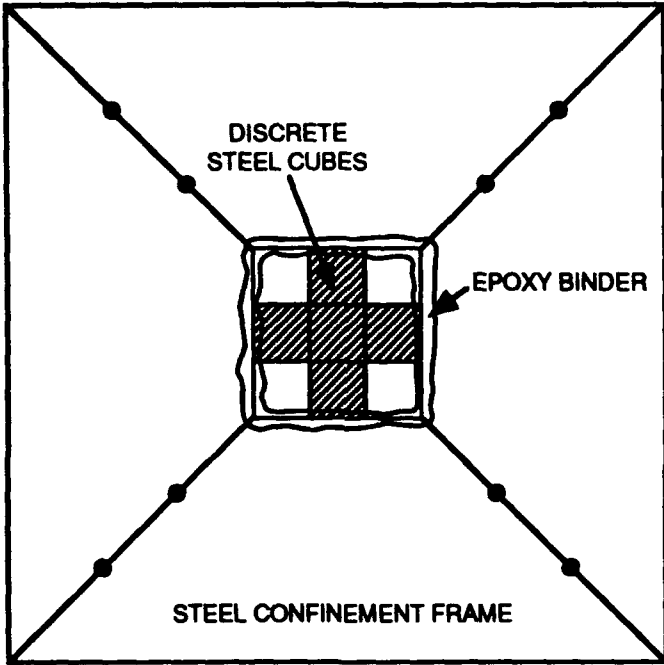
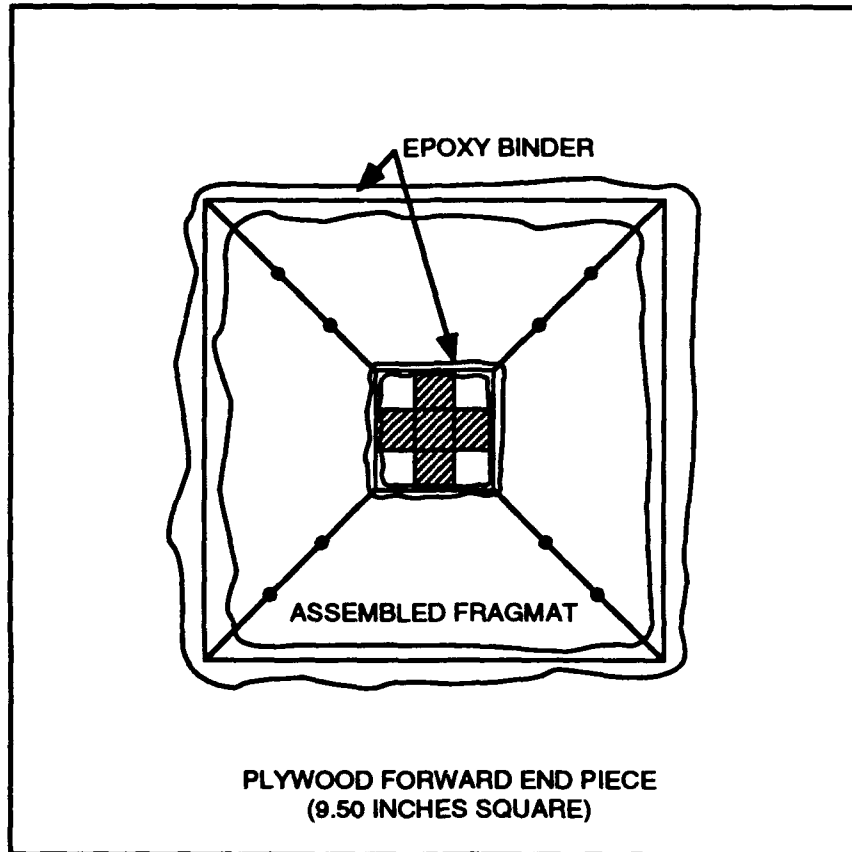


FIGURE B-3. Five-Cube Fragment Configuration.

**ASSEMBLY OF FRAGMENT PROJECTOR END PIECES**

1. Cut a 6.9-inch-square hole in the center of a 0.75-inch-thick  $\times$  9.5-inch-square plywood end piece (forward end piece).
2. Place the forward end piece on a flat surface, and position an assembled confinement frame (concave face down) into the square hole of the end piece.
3. Prepare the fast-curing epoxy binder in accordance with the manufacturer's instructions.
4. Spread the fast curing epoxy binder over the confinement frame and the adjacent edges of the plywood end piece, as shown in Figure B-4. Allow the epoxy binder to cure completely before handling the forward end piece.
5. Drill five 0.75-inch-diameter holes through a 0.75-inch-thick  $\times$  9.5-inch-square plywood board (aft end piece) at the locations shown in Figure B-5.
6. The forward and aft end closures are now ready to attach to the explosive projector charge.



**FIGURE B-4. Assembled Fragment Projector Forward End Piece.**

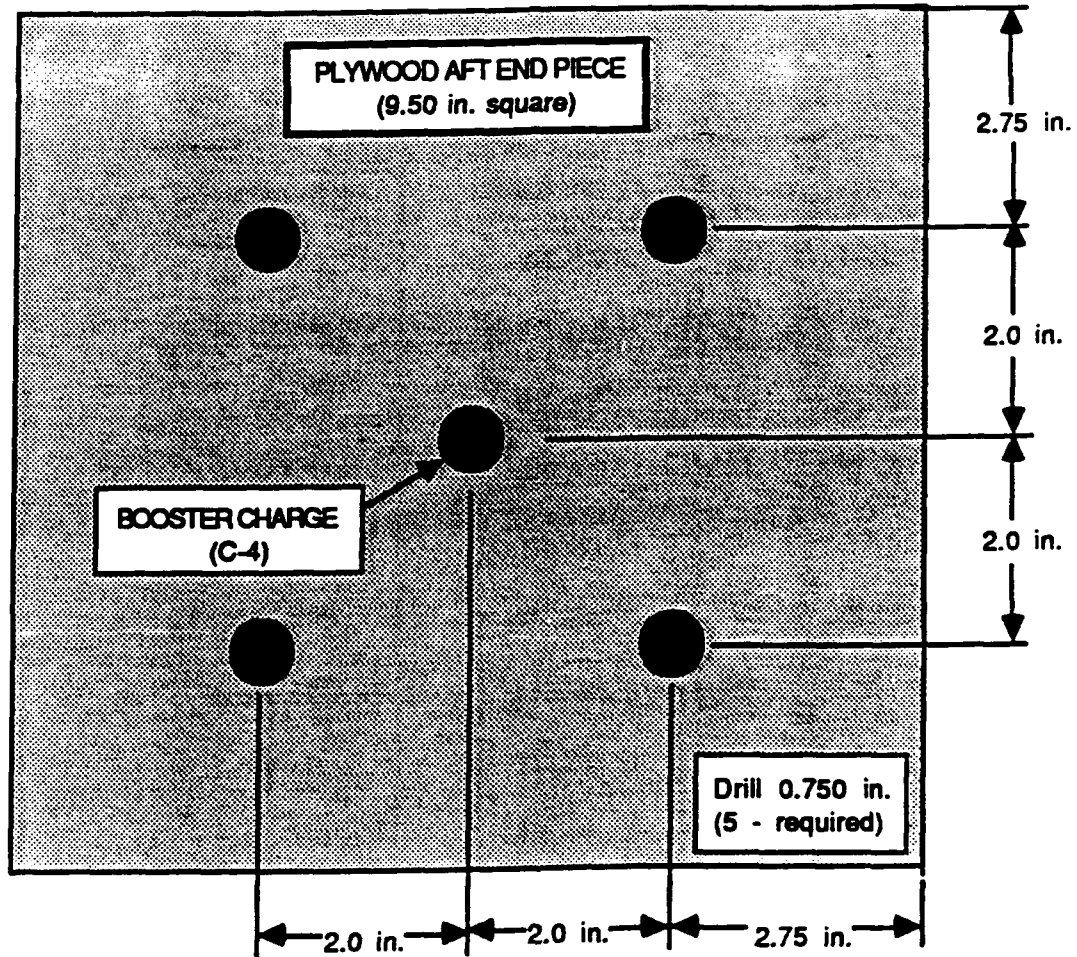


FIGURE B-5. Fragment Projector Aft End Piece.

**SELECTING CHARGE SIZE, WEIGHT**

Table B-1 is provided as a guide to selecting the explosive length required to achieve the desired velocity. The explosive charge weight is based on Composition B explosive having a density of 0.05961 lb/in<sup>3</sup>. The width and height dimensions of the explosive charge are 8 inches × 8 inches, respectively.

The information contained in Table B-1 was extrapolated from test data (closed cubes, no gas check) and presented in NWC TM 6411 (Reference 3 of main report).

**TABLE B-1. Fragment Velocity Versus Explosive Charge Length (Approximate).**

Explosive Length (L), in (approximate)	Explosive Charge Weight, lbs (approximate)	Desired Velocity, ft/s
9.02	34.43	6,000
9.36	35.69	6,500
9.69	36.96	7,000
10.02	38.24	7,500
10.35	39.50	8,000
10.55	40.26	8,300
10.68	40.77	8,500
11.02	42.04	9,000
11.35	43.31	9,500
11.68	44.58	10,000

Through actual test use, Table B-1 has been found to be skewed in some areas with regard to weight versus velocity, and it is recommended that, before any actual live tests are performed, a calibration test be conducted to verify the chosen projector box length for the intended batch of Composition B to achieve the required velocity.

## **EXPLOSIVE CHARGE REMOTE CUTTING**

**This procedure must be performed remotely.** The plywood mold is not removed prior to cutting the Composition B explosive. The plywood box is cut along with the Composition B filler. There are two precautions to be taken when cutting the mold and Composition B together. First, use plenty of coolant such as fresh, clean water when cutting. Second, be extremely careful not to turn the charge right side up without holding the bottom of the charge, or the explosive filler may fall out of the mold box.

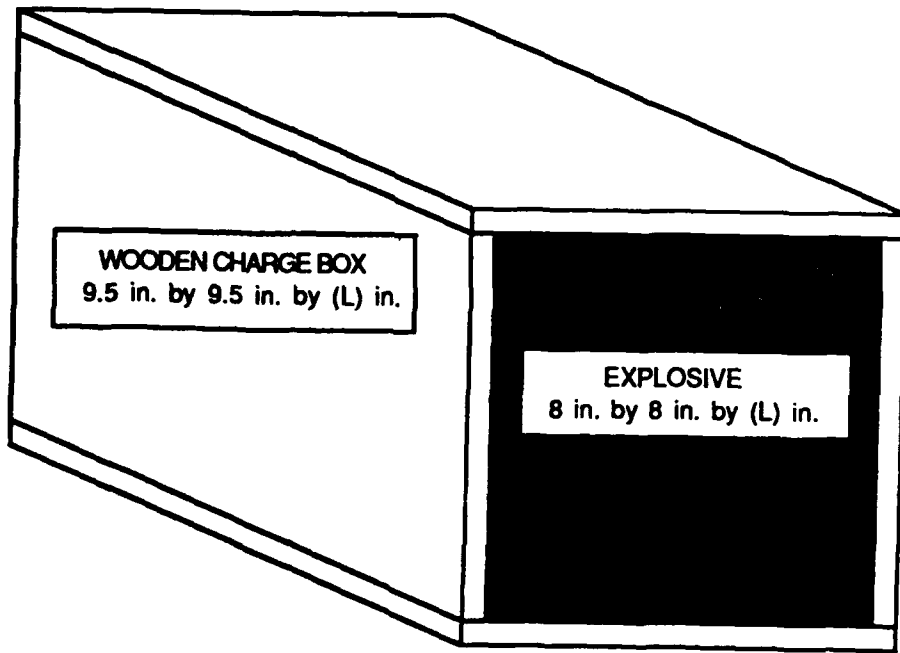
1. Remove approximately 1.25 inches off the bottom of the cast explosive box. The section that is removed will consist of the bottom mold end piece and 0.5 inch of explosive material. Visually inspect the exposed explosive for any defects caused by the cutting operation, or any defects that occurred during the melt cast such as cracks or voids. If the boxes were sent to X-ray, any anomalies should have been apparent when viewing the X-ray film.

2. Measure from the exposed explosive end and cut the explosive projector charge to the predetermined size. Visually inspect all charges as they are cut to ensure no defects that would cause loss of velocity or problems during use are present in any of the charges. The ends of the explosive should be flush with the ends of the mold boxes.

3. Determine the total weight of the charge box; compute and record the weight of the explosive contained within the mold box. The weight per unit length of the plywood mold box is determined in Appendix A. An explosive projector charge box is shown in Figure B-6.

4. Cover the exposed surfaces of the Composition B explosive with the 9.5-inch-square sheets of grease-proof cardboard and tape in place. Identify the explosive projector box with an appropriate serial number and weight.

5. The cut projector charge boxes can be stored until final assembly takes place. Final assembly procedures are described in the following section.



**FIGURE B-6. Explosive Projector Charge Box.**

## EXPLOSIVE PROJECTOR CHARGE ASSEMBLY

An assembled explosive projector charge is shown in Figure B-7. The required materials are:

- a. Fabricated explosive charge box.
- b. Booster explosive (Composition 4 or N-5 pellets).
- c. Forward and aft assembled end pieces.
- d. Fast-curing epoxy binder (two-part mix).

The explosive charge projector will be assembled in the following manner.

**Observe all Safety Precautions When Handling Energetic Materials.**

1. Remove the grease-proof cardboard cover from the ends of the precut explosive charge box. Ensure that Composition B is flush at both ends of the plywood box.
2. Prepare an adequate amount of epoxy binder in accordance with the manufacturer's directions to cover one end of the plywood box.
3. Epoxy the forward end, concave face down or in, to one end of the explosive charge box. Tape is commonly used as an additional method to ensure the end piece does not move while the epoxy is curing. It should be noted that due to the 5-degree beveling of the steel confinement frame, there is a small clearance between the forward surface of the explosive charge and the aft surface of the fragment cubes. There is no direct contact between the fragment cubes and the Composition B explosive. The confinement frame sides do make contact at the outside edges of the frame.
4. Prepare an additional amount of epoxy binder in accordance with the manufacturer's directions.
5. Epoxy the aft end piece to the opposite end of the explosive charge box. Tape the end piece in place to ensure it does not move while the epoxy is curing.
6. A booster explosive is required due to the difficulty of initiating the Composition B explosive. A commonly used booster explosive is Composition 4, with an alternate being N-5 pellets.
7. If Composition 4 is used as a booster explosive, the Composition 4 explosive will be potted directly against the face of the Composition B explosive in the 0.75-inch-diameter holes (5 holes required) that were drilled per Figure B-5. The explosive charge detonators are then fitted into the Composition 4 booster explosive in holes made using a piece of wood having the same diameter as that of the charge detonators.
8. If N-5 pellets are used as the booster explosive, 0.75-inch-diameter  $\times$  0.75-inch-long pellets are inserted in the five holes in the plywood aft end, so that the pellets butt against the aft face of the Composition B explosive.

9. To ensure the explosive charge detonators stay in contact with the N-5 pellets, another piece of plywood, 0.75 inch thick  $\times$  9.5 inches square, must be cut as an end piece. The five holes are drilled in the same pattern as indicated in Figure B-5, with the exception that the hole diameter is matched to the explosive charge detonator diameter. This modified end piece is then taped or epoxied over the existing end piece (with the N-5 pellets in place), and the explosive charge detonators are inserted to butt against the N-5 pellets.

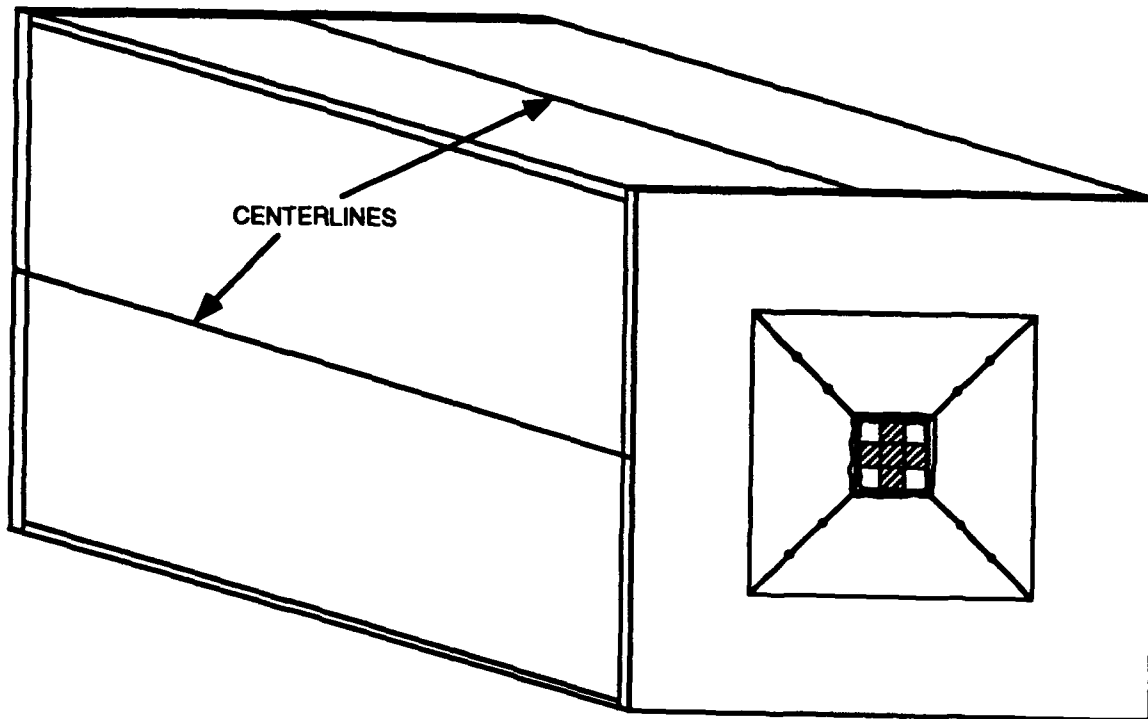
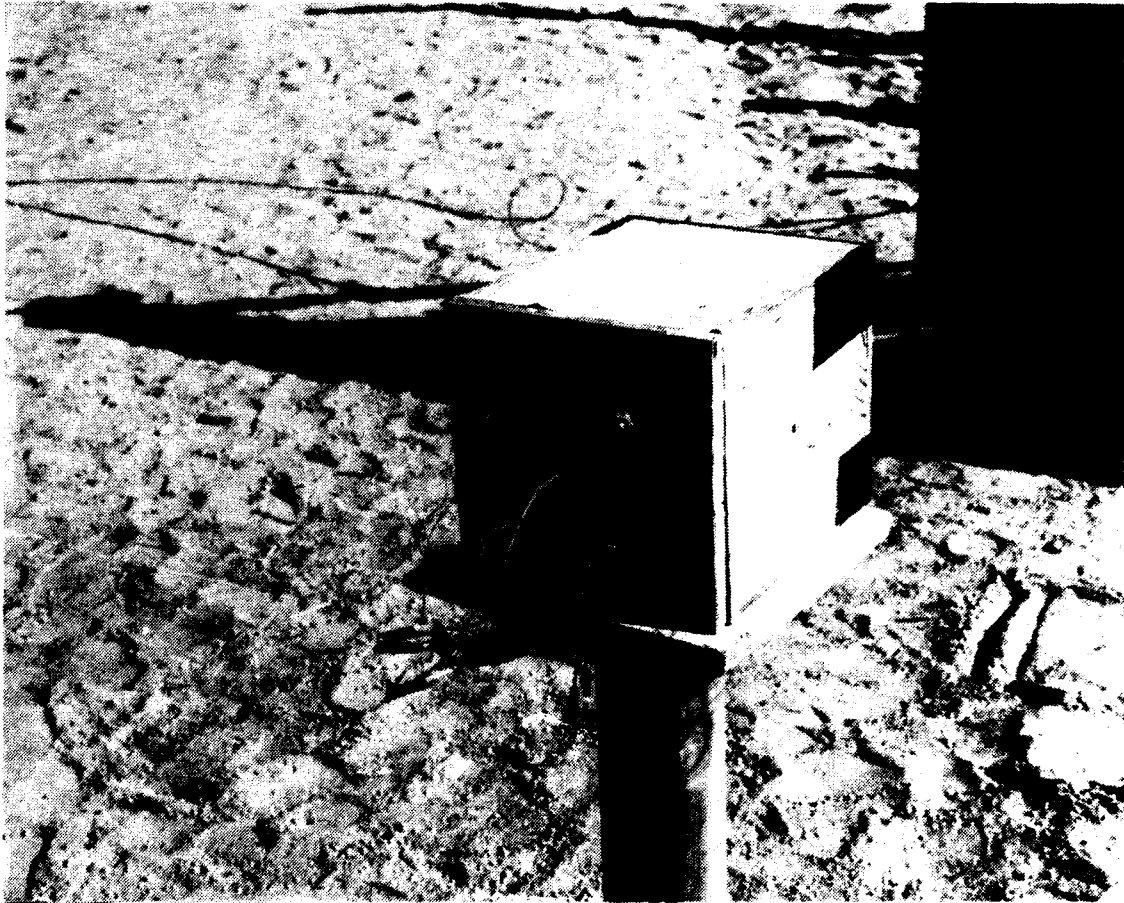


FIGURE B-7. Assembled Projector Charge Box.

Figure B-8 shows a fully assembled 5-cube FRAGMAT projector box. The photograph shows the five Composition 4 boosters in the holes in the aft end piece. In this instance, plastic pipe fittings have been used to form the receptacle for the Composition 4 explosive. Centered in the boosters are the RP-83 detonators. The projector shown is wired for firing.



**FIGURE B-8. Photograph of Assembled Projector Charge Box Showing Composition 4 Boosters and RP-83 Detonators in Position for Firing.**



NAWCWPNS TP 8062

- 4 Naval Surface Warfare Center Division, Indian Head, MD
  - Code 04, M. Hudson (1)
  - Code 20 (1)
  - Code 340, L. Miller (1)
  - Code 8420G, Standardization Branch (1)
- 17 Naval Surface Warfare Center Division, White Oak Detachment, Silver Spring, MD
  - Code G08
    - E. P. Johnson (1)
    - R. Kavetsky (1)
  - Code G40
    - J. Bagnall (1)
    - D. Grenier (1)
  - Code G411, A. Munach (1)
  - Code G81, O. Parrent (1)
  - Code R04, Dickinson (1)
  - Code R10B, Haiss (1)
  - Code R10H, Swisdak (1)
  - Code R101, Roslund (1)
  - Code R12, Spahn (1)
  - Code R13, P. Miller (1)
  - Code R16
    - Baudler (1)
    - Mensi (1)
  - Code R35, Dr. B. Smith (1)
  - Code U32, O. Parrent (1)
  - Technical Library (1)
- 2 Naval Undersea Warfare Center Division, Keyport, WA
  - Code 04, K. Scott (1)
  - C. Webb (1)
- 4 Naval Weapons Station Earle, Colts Neck, NJ
  - Packing, Handling, Storage and Transportability Center
    - Code 5011, Bender (1)
    - Code 5014, Sova (1)
    - Code 5021, Lee (1)
    - Code WH-805 (1)
- 1 Office of Naval Technology, Arlington, VA
- 1 Army Armament, Munitions and Chemical Command, Picatinny Arsenal, NJ (AMCPM-AL, W. Liska)
- 1 Army Armament, Munitions and Chemical Command, Rock Island, IL (AMSMC-DSM-D, M. Johnson)
- 3 Army Materiel Command, Alexandria, VA
  - AMCAM-LG, R. Fahy (1)
  - AMCDNR-IP (1)
  - AMCSF-S (1)
- 1 Army Materiel Command, Field Safety Activity, Charlestown, IN (AMXOS-SE, P. Yutmeyer)
- 11 Army Missile Command, Redstone Arsenal, AL
  - AMSMI-RD (1)
  - AMSMI-RD-PR (1)
  - AMSMI-RD-PR-E, D. Dreitzler (1)
  - AMSMI-RD-PR-T
    - J. Murfree, Jr. (1)
    - L. B. Thorn (1)
  - AMSMI-RD-SE (1)
  - AMSMI-RD-SF (1)
  - AMSMI-RD-ST (1)
  - AMSMI-RD-TE (1)
  - AMSMI-RD-TE-F, J. Porter (1)
  - AMSMI-RD-TE-S, J. Knorr (1)
- 3 Army Test and Evaluation Command, Aberdeen Proving Ground, MD
  - AMSTE-TA (1)
  - AMSTE-TC-D, H. Egbert (1)
  - AMSTE-TC-M, R. Hayes (1)
- 3 Office of the Secretary of the Army, Washington, DC
  - DACS-SF, R. Fatz (1)
  - DALO-SMA (1)
  - JDPSS-SAF (1)
- 22 Army Armament Research Development and Engineering Center, Picatinny Arsenal, NJ
  - AMCPM-FZ (1)
  - AMSMC-QA(D) (1)
  - AMSMC-QAR(D) (1)
  - AMSMC-QAU(D) (1)
  - AMSMC-QAW(D) (1)
  - SLCHE-AR (1)
  - SMCAR-AEC-TE, E. Stewart (1)
  - SMCAR-AEE, M. Mezger (1)
  - SMCAR-AEE-B (1)
  - SMCAR-AEE-W (1)
  - SMCAR-AEF-C (1)
  - SMCAR-AEM, P. Serao (1)
  - SMCAR-AEP (1)
  - SMCAR-AES (1)
  - SMCAR-BAC-S (1)
  - SMCAR-CC (1)
  - SMCAR-ESW-F(R) (1)
  - SMCAR-FMS-S, Saks (1)
  - SMCAR-FS (1)
  - SMCAR-FSM (1)
  - SMCAR-SF, A. Larson (1)
  - P. Lu (1)
- 3 Army Ballistic Research Laboratory, Aberdeen Proving Ground, MD
  - SLCBBR-TB-B (1)
  - SLCBBR-TB-BB (1)
  - SLCBBR-TB-EE (1)

NAWCWPNS TP 8062

- 2 Army Combat Systems Test Agency, Aberdeen Proving Ground, MD
  - STECs-SOM
  - R. Gil (1)
  - R. Shipe (1)
- 4 Army Defense Ammunition Center and School, Savanna, IL
  - SMCAC-ES, G. Abrisz (1)
  - SMCAC-ESP
  - S. Blunk (1)
  - J. Byrd (1)
  - SMCAC-ESS, Dr. S. Kwak (1)
- 2 Army Engineer Waterways Experiment Station, Vicksburg, MS
  - CEWES-SE, L. K. Davis (1)
  - CEWES-SS, S. Woodson (1)
- 1 Army Ordnance Missile and Munitions Center and School, Fort McClellan, AL (ATSK-CMT-Z)
- 1 Army Safety Center, Fort Rucker, AL (CSSC-PR)
- 1 Army Technical Center for Explosive Safety, Savanna, IL (SMCAA-ES)
- 1 Army Toxic and Hazardous Materials Agency, Aberdeen Proving Ground, MD (DRXTH-TE)
- 1 Dugway Proving Ground, Dugway, UT (MT-TM-A)
- 2 White Sands Missile Range, New Mexico
  - STEWs-TE-N (1)
  - STEWs-TE-NP (1)
- 3 Air Force Phillips Laboratory, Edwards Air Force Base, CA
  - C. Merrill (1)
  - F. Roberto (1)
  - R. Weiss (1)
- 1 Air Force Safety Agency, Kirtland Air Force Base, NM (AFSA/SEW, Chief Master Sergeant T. Betts)
- 1 Air Force Weapons Laboratory, Kirtland Air Force Base, NM (AFWL/NTE)
- 11 Air Force Wright Laboratories, Armament Directorate, Eglin Air Force Base, FL
  - ASC/YMEA (2)
  - Crockett (PMA-268) (1)
  - ASC/SES, West (1)
  - ASC/YQY, Jenus (1)
  - MSD/ENS (1)
  - WL/MNME
  - Corley (1)
  - Glenn (1)
  - Dr. R. McKenney, Jr. (1)
  - Parsons (1)
  - WL/MNMW, Foster (1)
- 2 Air Force Wright Laboratories, Dynamic Directorate, Wright-Patterson Air Force Base, OH
  - WL/GFW, W. Rieder (1)
  - A. Kurtz (1)
- 3 Air Logistics Center, Hill Air Force Base, UT
  - ALC/MMW (1)
  - ALC/MMWE (1)
  - TIRRPN, 6501 Range Squadron (1)
- 1 Defense Logistics Agency, Marietta, GA (K. Siler, Jr.)
- 1 Defense Nuclear Agency, Alexandria, VA (Code LEEE)
- 1 Defense Nuclear Agency, New Mexico Test Operations, Kirtland Air Force Base, NM (Code TDNM-S)
- 1 Defense Nuclear Agency, Washington, DC (Code TDTR)
- 2 Defense Technical Information Center, Alexandria, VA (FDAC)
- 3 Department of Defense Explosives Safety Board, Alexandria, VA
  - DDESB-IK (1)
  - DDESB-KT (1)
  - Dr. J. Ward (1)
- 1 Deputy Assistant Secretary of Defense, Washington, DC (DASD/FSE&S)
- 1 Executive Director for Explosives Safety, Alexandria, VA (AMCDNR)
- 1 Military Traffic Management Command, Falls Church, VA (MT-SS)
- 1 Office of the Assistant Secretary of Defense, Washington, DC (FM&P/SE&S)
- 4 Office of the Secretary of Defense, Washington, DC
  - ADDR&E/T&E(SP), R. Ledsma (1)
  - ADDR&E/T&E(TFR), D. French (1)
  - OUSDRE(OM) (1)
  - USD(A)/DDRE(R&AT/ET), R. Menz (1)

- 1 Department of Transportation, Washington, DC (DHM-21, C. Shultz)
- 2 Lawrence Livermore National Laboratory, Livermore, CA
  - L-38, Military Applications (1)
  - Technical Library (1)
- 3 Los Alamos National Laboratory, Los Alamos, NM
  - Group M7, McAfee (1)
  - Group M8, Asay (1)
  - Technical Library (1)
- 1 National Security Agency, Fort George G. Meade, MD (Code G74(TA))
- 2 Sandia National Laboratories, Albuquerque, NM
  - Code 7553, M. Morris (1)
  - Code 9122, R. Braash (1)
- 1 Advanced Technology, Incorporated, Arlington, VA
- 2 Aerojet Propulsion Division, Sacramento, CA
  - Tactical Propulsion and Munitions, H. Whitfield (1)
  - Tactical Systems, D. Snyder (1)
- 1 Aerojet Solid Propulsion, Sacramento, CA (G. Manser)
- 2 Alliant Techsystems, Incorporated, Brooklyn Park, MN
  - Dr. K. Christianson (1)
  - K. Emerson (1)
- 1 Alliant Techsystems, Incorporated, Ridgecrest, CA
- 1 Applied Ordnance Technology, Arlington, VA
- 2 Atlantic Research Corporation, Gainesville, VA
  - K. Graham (1)
  - Dr. R. Snyder (1)
- 1 Atlantic Research Corporation, Ridgecrest, CA (R. Miller)
- 1 BEI Defense Systems Company, Fort Worth, TX (W. S. Marks)
- 1 Bobby G. Craig, Consultant, Energetic Materials, Niceville, FL
- 1 Boeing Aerospace and Electronics, Ridgecrest, CA (G. Ebling)
- 2 Chamberlain Manufacturing Corporation, Waterloo, IA (J. Stotser)
- 1 COMARCO, Incorporated, Weapons Support Division, Ridgecrest, CA (R. Dettling)
- 1 Denver Research Institute, Denver CO (Technical Library)
- 1 Fiest Engineering, Incorporated, Ridgecrest, CA
- 1 Hercules, Incorporated, McGregor, TX
- 1 IIT Research Institute, Chicago, IL (Technical Library)
- 1 Institute of Makers of Explosives, Washington, DC
- 1 Kilkeary, Scott & Associates, Incorporated, Arlington, VA
- 1 Lockheed Missiles & Space Company, Incorporated, Santa Cruz, CA (J. Farmer)
- 1 Lockheed Missiles & Space Company, Incorporated, Sunnyvale, CA
- 1 Martin Marietta Energy Systems, Incorporated, Oak Ridge, TN (D. Welch)
- 1 Martin Marietta Missile Systems, Orlando, FL
- 1 Mason and Hanger, Amarillo, TX (A. G. Papp)
- 1 McDonnell Douglas Missile Systems Company, St. Louis, MO (Dept. E261, Mail Code 1063663)
- 1 Motorola, Incorporated, Scottsdale, AZ
- 1 Napadensky Engineers, Incorporated, Evanston, IL
- 2 New Mexico Institute of Mining and Technology, Socorro, NM
  - CETR, P. A. Persson (1)
  - TERA, P. McLain (1)
- 1 Olin Ordnance, Washington, DC
- 1 Olin Ordnance, St. Petersburg, FL
- 1 Raytheon Company, Missile Systems Division, Bedford, MA
- 4 Southwest Research Institute, San Antonio, TX
  - P. Bowles (1)
  - W. Herrera (1)
  - Technical Library (1)
  - P. Zabel (1)
- 2 Tactical Product Engineering Propulsion Division, Sacramento, CA
  - R. Brogan (1)
  - J. W. Jones (1)
- 1 The Johns Hopkins University, Applied Physics Laboratory, Chemical Propulsion Information Agency, Laurel, MD
- 1 Thiokol, Incorporated, Huntsville, AL (W. Thomas)
- 2 Thiokol, Incorporated, Brigham City, UT
  - Tactical Division (1)
  - Wasatch Operations, P. Nance (1)

- 1 Victor Technology, Ridgecrest, CA
- 1 VITRO, Washington, DC
- 1 Wyle Laboratories, El Segundo, CA (P. Turkheimer)
- 1 AWE Foulness Island, Southend-on-Sea, United Kingdom
- 1 CINO/DDEWS, Ministry of Defence, United Kingdom
- 2 Defence Research Establishment Valcartier, Canada
  - C. Belanger (1)
  - J. F. Drolet (1)
- 1 DRIC, Kentigern House, United Kingdom (S. Smith)
- 1 DSTO/Materials Research Laboratory, Explosives Division, Australia (M. C. Chick)
- 1 DSTO/Weapons Systems Research Laboratory, Ordnance Systems Division, Australia (L. Barrington)
- 1 IETA, DGA/DCN Lorient, France (O. Saliou)
- 1 IJWA Boss van Charante, the Netherlands
- 1 NATO Insensitive Munitions Information Center, Belgium
- 1 RARDE/NP1, United Kingdom
- 1 RARDE S/NP1 Division, United Kingdom
- 1 Royal Ordnance Place, United Kingdom (Dr. P. R. Lee)
- 1 Royal Ordnance Rocket Motors Division, United Kingdom