

UNCLASSIFIED

AD-A268 954

2

SECURITY CLASSIFICATION OF THIS PAGE

REPC



Form Approved OMB No. 0704-0188

1a. REPORT SECURITY CLASSIFICATION UNCLASSIFIED		1b. RESTRICTIVE MARKINGS	
2a. SECURITY CLASSIFICATION AUTHORITY		3. DISTRIBUTION / AVAILABILITY OF REPORT Approved for public release; distribution unlimited	
2b. DECLASSIFICATION / DOWNGRADING SCHEDULE		4. PERFORMING ORGANIZATION REPORT NUMBER(S) Test Operations Procedure (TOP) 4-2-025	
5. MONITORING ORGANIZATION REPORT NUMBER(S) Same as item 4		6a. NAME OF PERFORMING ORGANIZATION U.S. Army Combat Systems Test Activity	
6b. OFFICE SYMBOL (if applicable) STECS-DA-ID		7a. NAME OF MONITORING ORGANIZATION U.S. Army Test and Evaluation Command	
6c. ADDRESS (City, State, and ZIP Code) Aberdeen Proving Ground, MD 21005-5059		7b. ADDRESS (City, State, and ZIP Code) Aberdeen Proving Ground, MD 21005-5055	
8a. NAME OF FUNDING / SPONSORING ORGANIZATION Same as Item 7a		8b. OFFICE SYMBOL (if applicable) AMSTE-CT-T	
9. PROCUREMENT INSTRUMENT IDENTIFICATION NUMBER		8c. ADDRESS (City, State, and ZIP Code) Same as Item 7b	
10. SOURCE OF FUNDING NUMBERS		11. TITLE (Include Security Classification) "Insensitive Munitions (IM) Tests" (U)	
PROGRAM ELEMENT NO.	PROJECT NO.	TASK N. DTIC ELECTE SEP 01 1993 S E D	WORK UNIT ACCESSION NO.
12. PERSONAL AUTHOR(S)		13a. TYPE OF REPORT Final	
13b. TIME COVERED FROM _____ TO _____		14. DATE OF REPORT (Year, Month, Day) 2 June 1993	
15. PAGE COUNT 45		16. SUPPLEMENTARY NOTATION	
17. COSATI CODES		18. SUBJECT TERMS (Continue on reverse if necessary and identify by block number)	
FIELD	GROUP	SUB-GROUP	Insensitive munitions
			Fragment impact
			Spall impact
			Cook-off Tests
			Witness plate
			Shaped charge
			Impact munition
			Sympathetic detonation
19. ABSTRACT (Continue on reverse if necessary and identify by block number) This TOP provides test methods to determine explosive safety and insensitive munitions (IM) characteristics for all non-nuclear munitions, munition subsystems and explosive devices to be fielded by the U.S. Army, and to synthesize all hazard-assessment tests recommended by MIL-STD-2105A and the guidance of the U.S. Army supplement to MIL-STD-2105A (Navy) into a single TOP for IM testing.			
20. DISTRIBUTION / AVAILABILITY OF ABSTRACT <input type="checkbox"/> UNCLASSIFIED/UNLIMITED <input type="checkbox"/> SAME AS RPT. <input type="checkbox"/> DTIC USERS		21. ABSTRACT SECURITY CLASSIFICATION UNCLASSIFIED	
22a. NAME OF RESPONSIBLE INDIVIDUAL		22b. TELEPHONE (include Area Code)	
		22c. OFFICE SYMBOL	

93 8 24 02 6

93-19690



4088

U.S. ARMY TEST AND EVALUATION COMMAND  
TEST OPERATIONS PROCEDURE

AMSTE-RP-702-103

Test Operations Procedure (TOP) 4-2-025

AD No.

2 June 1993

INSENSITIVE MUNITIONS (IM) TESTS

		<u>Page</u>
Paragraph 1.	SCOPE . . . . .	1
2.	FACILITIES AND INSTRUMENTATION . . . . .	2
3.	REQUIRED TEST CONDITIONS . . . . .	4
4.	TEST PROCEDURES . . . . .	6
4.1	Basic Safety Tests. . . . .	6
4.1.1	28-Day Temperature and Humidity Test. . . . .	6
4.1.2	Vibration Test . . . . .	9
4.1.3	4-Day Temperature and Humidity Test . . . . .	9
4.1.4	12-Meter (40-Ft) Drop Test . . . . .	9
4.2	Fast Cook-off Test . . . . .	11
4.3	Slow Cook-off Test . . . . .	14
4.4	Bullet-Impact Test . . . . .	18
4.5	Fragment-Impact Test . . . . .	21
4.6	Sympathetic Detonation Test . . . . .	25
4.7	Shaped-Charge-Jet Impact Test . . . . .	30
4.8	Spall-Impact Test . . . . .	32
5.	PRESENTATION OF DATA . . . . .	35
Appendix A	HISTORICAL INFORMATION ON IM TESTING. . . . .	A-1
B	DETERMINING THE TYPE OF REACTION . . . . .	B-1
C	COMPLETING THE POST-TEST REMAINS MAP AND TABULATION CHART . . . . .	C-1
D	REFERENCES . . . . .	D-1

1. SCOPE. This TOP provides test methods to:

a. Determine explosive safety and insensitive munitions (IM) characteristics for all non-nuclear munitions, munition subsystems and explosive devices to be fielded by the U.S. Army. Historical information on the IM testing is contained in Appendix A.

b. Synthesize all hazard-assessment tests recommended by MIL-STD-2105A<sup>1\*</sup> and the guidance of the U.S. Army Supplement to MIL-STD-2105A (Navy)<sup>2</sup> into a single TOP for IM testing.

Unannounced Justification <input checked="" type="checkbox"/>	
By _____	
Distribution / _____	
Availability Codes	
Dist	Avail and/or Special
<b>A-1</b>	

\*Superscript numbers/letters correspond to those in Appendix D.

Approved for public release; distribution unlimited.

**Reproduced From  
Best Available Copy**

DTC QUALITY INSPECTED 1

TOP 4-2-025  
2 June 1993

2. FACILITIES AND INSTRUMENTATION.

2.1 Facilities.

<u>Item</u>	<u>Requirement</u>
Temperature chamber	Capable of conditioning test items to temperatures ranging from 71 °C to -51 °C, $\pm 2$ °C and relative humidities from 5% to 95%.
Industrial X-ray facility	To perform radiographic inspection for conformance to applicable specifications.
Vibration test facility	To produce rectilinear, simple, harmonic motion with capabilities for measurement of force, weight of load, and vibration-frequency range.
Drop test facility	To perform unimpeded, 12-meter (40-ft) drops. The facility consists of a tower, guidance system, and support assembly.
Remote-handling equipment	To remove unexploded ordnance.
Fast cook-off facility	To provide a controlled flame which completely engulfs the test item at the specified temperature for the cook-off test duration.
Slow cook-off facility	To provide an oven-like heat source and a vessel for the containment of exudant and other bi-products of the slow cook-off test.
Impact test facility	To provide a test area for the performance of bullet-impact, shaped-charge-jet impact, spall-impact, and fragment-impact tests. The test area shall be large enough to accommodate the maximum effective range of each impact device. The test facility shall provide fixtures to support and restrain the test item.

<u>Item</u>	<u>Requirement</u>
Sympathetic detonation facility	To provide the packaging conditions and stowage arrangements which pose the greatest threat of sympathetic detonation based on the threat-hazard assessment (THA).
Still-photography equipment	To record the condition of the test item and test setup before and after testing.
High-speed framing camera	To record the striking velocity of an impacting projectile, or the reaction of a test item.
Video or motion-picture sound photography	To record the striking velocity of an impacting projectile, or the reaction of a test item.

## 2.2 Instrumentation.

<u>Devices for Measuring:</u>	<u>Permissible Error of Measuring Device:</u>
Relative humidity at the control sensor	$\pm 5\%$ of reading
Vibration sweep time	$\pm 3\%$ of reading
Vibration frequency	$\pm 0.5$ Hz from 5-52 Hz; $\pm 2$ Hz from 53-500 Hz
Drop height	$\pm 5\%$ of reading
Impact angle for the drop test	$\pm 10$ degrees
Suspension height for cook-off test	$\pm 5\%$ of reading
Projectile velocity (guidance in ITOP 4-2-805 <sup>3</sup> )	$\pm 0.1\%$ of reading or $\pm 0.5$ m/s (whichever is higher)
Weight	$\pm 1\%$ of reading
Airblast overpressure	Minimum frequency response of 20 kHz.

2 June 1993

3. REQUIRED TEST CONDITIONS

3.1 Test Planning

a. As a minimum, the following test schedule is required in accordance with MIL-STD 2105A:

(1) Three rounds each undergo the following basic safety tests in succession:

(a) 28-day temperature-and-humidity test.

(b) Vibration test.

(c) 4-day temperature-and-humidity test.

(d) 12-meter (40-ft) drop test.

(2) Two rounds each undergo a fast cook-off test.

(3) Two rounds each undergo a slow cook-off test.

(4) Two rounds each undergo a bullet-impact test.

(5) Two rounds each undergo a fragment-impact test.

(6) Five rounds undergo one or more sympathetic detonation tests. The placement of the rounds, and the individual designation for each round (donor or acceptor), shall be based on the threat-hazard assessment (THA).

(7) Two rounds each undergo shaped-charge-jet impact tests if the item contains propellant, a propelling charge, or a rocket motor.

(8) Two rounds each undergo spall-impact tests.

b. A test plan will be prepared to list all tests which apply to the particular test item. If the test plan does not contain the minimum test schedule outlined in MIL-STD-2105A, or the test plan contains additional tests for the evaluation of munition sensitivity, an explanation should be provided. All test plans will be reviewed and approved by the appropriate service-review organization.

c. MIL-STD-2105A recommends that at least 20 test items are required to complete the minimum test schedule. The number of rounds per subtest (especially in the fast cook-off, slow cook-off, bullet-impact, fragment-impact, shaped-charge impact and spall-impact tests which have a sample size of only two) should be increased to obtain test repeatability and confidence if the rounds are available for these tests.

d. Depleted uranium (DU) projectiles in ammunition containing DU shall be replaced with slug or steel projectiles prior to all testing for safety and environmental reasons.

### 3.2 Test Items.

a. The test item shall be either production hardware or its design equivalent. All packaging and accessory items customarily used to store and transport the test item shall also be supplied.

b. Upon receipt of the test items, each item shall be identified with a unique number to be used throughout testing. This number should be traceable to a corresponding manufacturer's serial number. If the test item is to be segregated into individual components, these components shall also be numbered in a similar manner. The following should be recorded for each test item or component:

- (1) Lot number and manufacturer.
- (2) Type, model, and caliber (if applicable).
- (3) Weight.
- (4) Dimensions (as measured according to TOP 1-2-504<sup>a</sup>).
- (5) Metallurgical defects (according to TOP 3-2-807<sup>b</sup>).
- (6) Propellant type, composition, web size, and propellant weight.
- (7) Date of manufacture.

c. The test item configuration shall duplicate the configuration of the item in the life-cycle phase simulated by the test. For any test, all electronic components and all other components not containing explosives which are not being employed shall be mechanically, geometrically, and thermally simulated.

d. Test items shall be mounted so the mounting mechanisms do not affect the munition response to the test stimulus.

e. With exception of the sympathetic detonation, vibration, and 12-meter (40-ft) drop tests, which require an all-up round (AUR), the munition may be tested on the major subsystem level, where the major subsystem is an element of an explosive system that contains explosive material and that, in itself, may constitute a system. Examples of explosive subsystems include warheads, fuzes, propulsion units, safe-and-arm devices, pyrotechnic devices and chemical payloads.

f. For the fast cook-off test, the test item may be tested in a simulated AUR configuration with the warhead and propulsion sections tested separately.

g. For the bullet-impact test, if the item caliber is less than or equal to 40 mm, the single item should be replaced by the fully loaded logistical package.

### 3.3 Pre- and Post-Test Requirements

a. Before each test, the test item shall undergo visual and radiographic inspection in accordance with MIL-STD-453<sup>6</sup>, to assure that no unusual conditions exist that may invalidate the tests. Still photography of the munition before the test is required for all tests except the sympathetic detonation test, and still photography of the test setup is required for the 28-day temperature-and-humidity test, vibration test, 4-day temperature-and-humidity test, 12-meter (40-ft) drop test, fast cook-off test, and slow cook-off test. Each photograph shall include identification information in the field of view which identifies the test item and test type.

b. After each test, all significant post-test remains will be photographed and recorded on a data sheet according to location (distance and radial angle from the pretest test item location), weight, size, and type (fin, electronics, casing, etc.). A preliminary determination of the reaction level (if any) based on the guidelines of MIL-STD-2105A and Appendix B shall be made and recorded along with the basis for the determination. If it is appropriate and safe, after each test (including each of the four portions of the basic safety tests) the test item shall undergo visual and radiographic inspection to determine its structural integrity. The data gathered from the inspections shall be compared with the pretest inspections to determine the amount of test item deterioration.

## 4. TEST PROCEDURES

### 4.1 Basic Safety Tests.

Four basic safety tests are performed in accordance with MIL-STD-2105A. These tests are applied in sequence to at least three test items beginning with a 28-day temperature-and-humidity test, followed by a vibration test, a 4-day temperature-and-humidity test, and finally a 12-meter (40-ft) drop test. All four basic safety tests shall be based on credible life-cycle threats in the environmental profile for the test item.

#### 4.1.1 28-Day Temperature-and-Humidity Test.

This test is designed to determine the response of a test item subjected to a high environmental stress state which may occur during the system's life cycle. The temperature-and-humidity test recommended by MIL-STD-2105A consists of alternating high and low temperatures every 24 hours at a fixed relative-humidity level for 28 days. The environmental-stress conditions, such as the values of relative humidity, high and low temperatures, will be selected with guidance from all applicable documents related to selecting environmental profiles and the THA. These conditions will be approved by the appropriate review organization before the initiation of testing. This test may be performed on the major subsystem level.

4.1.1.1 Test facilities. Test facilities, chambers, and apparatus used in conducting the tests shall comply with ITOP 4-2-820<sup>7</sup>.

4.1.1.2 Method.

- a. Conduct a radiographic inspection of each round.
- b. Conduct a visual inspection of each round and record the following information:
  - (1) Visible pretest damage or anomalous conditions.
  - (2) All applicable lot and serial numbers.
  - (3) Name of the manufacturer.
- c. Take still photographs of the test item and the test setup.
- d. Place the test items inside the climatic chamber in a position which allows free air to flow around all portions of each item. Set the temperature inside the chamber to 49° C with no humidity control for 24 hours. (This ensures that the test item(s) is dry before the test begins.)
- e. Select the relative-humidity level and chamber temperature derived from the environmental profile for the first 24-hour period. (The first period can be either one of the two temperature extremes.) The time to reach the selected temperature-and-humidity level shall not exceed 30 minutes.
- f. Monitor the temperature-and-humidity levels for 24 hours.
- g. Inspect the test item for exudation or evidence of deterioration. If exudation is noticed, exudate shall be collected for chemical analysis.
- h. Keeping the relative-humidity level constant, change the temperature level to the opposite extreme. The time to reach the selected temperature shall not exceed 30 minutes.
- i. Repeat steps e, f, and g until all test periods (total of 28 days at the two temperature extremes) have been conducted. Note: If the test is interrupted for any reason and operations are required to be suspended, the test item shall be maintained at the last test environment for the entire period of the interruption.
- j. Return internal chamber conditions to standard ambient conditions of 25° C  $\pm$ 10°, and 20% to 80% relative humidity.
- k. Conduct a visual inspection of the test item and record any evidence of deterioration. Take still photographs of the test item and test setup.
- l. Conduct a radiographic inspection of the test item.

2 June 1993

4.1.1.3 Data required.

a. Before performing the test, the following data are required:

- (1) Nomenclature; lot, serial numbers, etc.
- (2) Name of the manufacturer.
- (3) Evidence of pretest damage to the munition.
- (4) Radiographs of each round.

b. During the test, the following data are required:

(1) Temperature measured by all chamber sensors, monitored continuously, recorded at least every 10 minutes during periods of constant temperature, and recorded at least every two minutes during transitional periods.

(2) Relative humidity of the climatic chamber measured by all chamber humidity sensors, monitored continuously, and recorded at least every 10 minutes.

(3) At the end of each transition period from low to high temperature, or vice versa, the item will be inspected for damage and exudation. Any damage or exudation will be recorded. If exudation exists, the test will continue and the exudate will be chemically analyzed.

(4) If munition reaction occurs, the following information should be recorded:

(a) Date and time of first reaction along with a description of the reaction events.

(b) Fragment sizes and descriptions (if any).

(c) Climatic chamber temperature and relative humidity.

c. Data required after the full 28 days include:

- (1) Evidence of post-test damage in excess of the pretest levels.
- (2) Radiographs of the munition.

(3) A full set of temperature and humidity measurements gathered throughout the test.

#### 4.1.2 Vibration Test.

This test is conducted to expose the test item to the most severe vibration environment the item is expected to encounter during the logistic cycle. This vibration environment shall be obtained from the THA. If the anticipated environment includes consideration of temperature effects, the testing should include temperatures other than the ambient conditions. Temperature recordings are required for all vibration tests. If the most severe vibration environment occurs when the test item is located in a container, the vibration test shall be conducted with the test item in the container. All rounds undergoing the basic safety tests shall be tested. Perform the test in accordance with ITOP 1-2-601<sup>8</sup>, or TOP 5-2-507<sup>9</sup>. The data from the radiographic inspection required after the 28-day temperature-and-humidity test may be used instead of conducting another radiographic inspection before the performance of the vibration test.

#### 4.1.3 4-Day Temperature-and-Humidity Test.

Same as paragraph 4.1.1 except test duration is 4 days rather than 28 days. If a radiographic inspection is conducted after performing the vibration test, these data may be substituted for the required radiographic inspection before the 4-day temperature-and-humidity test.

#### 4.1.4 12-Meter (40-ft) Drop Test.

This test simulates the test item's bare configuration stress-state during accidental free fall onto a hard impact surface. The 12-meter drop test mandated by MIL-STD-2105A is slightly different than the drop tests described in ITOP 4-2-601<sup>10</sup>, MIL-STD-331B<sup>11</sup>, and ITOP 5-2-619<sup>12</sup>. Approval must be given by the appropriate review organization if it is desirable to use the test procedures contained in either of these three documents, or to deviate from the following method provided in this TOP.

4.1.4.1 Test site. The drop-test facility shall include a tower, quick-release mechanism, an optional guidance system, and an impact surface. Additional requirements are as follows:

a. The striking plate shall be:

(1) Reasonably flat, smooth steel with a minimum thickness of 75 mm and a Brinell hardness of not less than 200.

(2) A length and width of at least one and one-half times the maximum dimension of the unit being tested to support the possible rebound of the test item.

(3) Solidly supported over its horizontal plane and bearing surface by a concrete or crushed-stone foundation with a minimum thickness of 60 cm.

(4) Horizontal to within 2 degrees, and not deformed from previous impacts to the point that it affects the impact angles, or causes some separation from the foundation material.

b. Guidance devices may be used to assure that a proper striking angle is achieved. These devices shall neither decrease the striking velocity by more than 1.5 m/sec (5 ft/sec) from the prescribed striking velocity of 15.2 m/sec (50 ft/sec), nor impede the rebound of the munition after initial impact.

4.1.4.2 Required and suggested instrumentation. If guidance devices are used, the striking velocity shall be measured to ensure the requirement for the striking velocity is met. High-speed framing cameras (400 frames per second, minimum), break screens, or any other viable method for measuring the striking velocity may be used. Closed-circuit video is suggested for recording the test event and the resulting impact damage. Mirrors or closed-circuit video cameras which capture the entire field of view around the drop tower are suggested for indirect view from the bombproof.

4.1.4.3 Method. For this test, use fully-live ammunition dropped in its bare-round configuration.

a. Inspect all elements of the drop-test system to ensure mechanical integrity.

b. Before any test items are dropped, drop a dummy weight to ensure mechanisms are working correctly.

c. Remove each test item from the temperature chamber one at a time, and perform the drop in a minimum time to avoid excessive temperature change. The temperature chamber should be located as close to the drop site as safety regulations permit.

d. Photograph the test item.

e. Insert the lifting plugs, or arrange a harness to suspend the munition from the quick-release mechanism. If used, the harness should adequately support the test item without interfering with the impact stimulus.

f. Attach the harness or lifting plug to the quick-release mechanism in the following orientations for the rounds allocated to the basic safety tests:

- One-third: Longitudinal axis horizontal
- One-third: Longitudinal axis vertical, top up
- One-third: Longitudinal axis vertical, top down.

g. Allow the round to hang just above the impact surface to ensure that impact occurs on the intended position on the striking plate.

h. Ensure that all velocity measurement equipment, and closed-circuit video (if used) is operational. If used, mirrors should be positioned to be viewed from the bombproof.

i. Evacuate all personnel from the immediate test area to approved shelters.

j. Raise the test item with the lifting plug or harness so the lowest point of the item is 12 meters (40 ft),  $\pm 5\%$ , above the impact surface.

k. Release the test item using the quick-release mechanism.

l. Observe a suitable waiting period before inspecting the test item, in accordance with pertinent safety regulations.

m. Take still photographs of the test item or remains.

n. Inspect the test item, and record the following:

(1) Damage to test item.

(2) Signs of release of explosive, propellant, or particles of projectiles.

(3) Indications of burning or detonation.

o. Remove the test item using Explosive Ordnance Disposal (EOD) personnel with remote-handling equipment, and destroy the item by standard means.

4.1.4.4 Data required. For each drop, record the following:

a. Damage to the test item.

b. Chamber temperature upon removal of the test item.

c. Description of the drop surface.

d. Orientation of the item at 12 meters (40 ft) before each drop.

e. Striking velocity.

4.2 Fast Cook-Off Test.

The purpose of the fast cook-off test is to record the test item response due to a rapid increase in temperature. An aircraft fuel fire with an average steady-state temperature of at least 870 °C (1600 °F) is used as the test stimulus. Any other alternate fuel is permitted, provided the 870 °C flame temperature is achieved.

2 June 1993

#### 4.2.1 Test Site.

The test site shall include an appropriate size fuel basin to accommodate a sufficient amount of hydrocarbon fuel to engulf the item in fire. To ensure complete engulfment, the dimensions of the basin should each be at least 3 meters greater than the corresponding test item dimensions. Some type of support structure shall be placed above the basin to suspend the item 91 cm (36 in.) above the fuel level and to keep the test item from falling into and being quenched by the fuel. Nevertheless, this support structure shall neither greatly affect the temperature distribution around the test item, nor alter the violence of the reaction. If the item contains a rocket motor, the item shall be restrained with fixtures to avoid launching due to a propulsive reaction. A reliable and safe method of igniting the fuel shall be selected. Protection shall be available for all operational personnel and is suggested for the photographic equipment.

#### 4.2.2 Required and Suggested Instrumentation.

Thermocouples with time constants of 2.0 seconds or less which are capable of withstanding flame temperatures of at least 870 °C are required to measure the temperature distribution around the test item. Temperature measurements as a function of time are required. The test activity should consider measuring the internal test item temperatures for useful data. If internal test item temperatures are measured, the thermocouples should be selected to withstand the same temperature profile as the thermocouples used to measure the flame temperature. At least one type of the following photographic evidence is required to record the response of the test item: motion-picture sound photography or video. The field of view shall be large enough to allow full view of the reaction, and the resolution shall be enough to discern which type of reaction (if any) occurs.

#### 4.2.3 Method.

a. By consulting engineering design drawings of the test item, determine the largest dimensions of the test item. Design a fuel pan at least 3 meters larger than the corresponding maximum dimensions of the test item. The depth of the fuel pan should be designed to hold a sufficient amount of hydrocarbon fuel to engulf the test item in flame until a reaction occurs. The flame duration is directly related to the depth of fuel in the pan. Initial small scale experiments should be carried out, or historical information consulted to determine the depth which produces an appropriate flame duration.

b. Determine the correct configuration of the test item in the logistical life-cycle phase being duplicated by the test. If the test item contains a rocket motor or propulsive device, design an appropriate restraining device or stopping structure to contain the test item if a propulsive reaction occurs during the fast cook-off test. If internal temperatures are to be recorded, insert the required thermocouples into the test item minimizing any changes to the test item or configuration.

c. Design an appropriate catch pan under the item to keep components of the test item from falling into and being quenched by the fuel fire. An open mesh is suggested for construction of the catch pan to minimize changes in the temperature distribution around the test item.

d. Select a suitable test area, as level as possible for the placement of the fuel pan. The test site should include an appropriate danger zone to accommodate a detonation reaction. The test site shall also include an area designated as the test control area. The test control area shall function as the safe area for personnel to view the reaction of the test item.

e. Position the fuel pan on the test site. To mitigate wind effects, it may be necessary to excavate a pit for placement of the fuel pan. Insert the test item support structure and the catch pan in the center of the fuel pan.

f. Position at least four thermocouples 10 to 20 cm from the outside of the ordnance skin on a horizontal plane passing through the centerline of the munition. One of the four thermocouples should be placed 10 to 20 cm in front of the nose of the munition, one thermocouple should be placed 10 to 20 cm away from the base of the munition, and the remaining two thermocouples should be placed 10 to 20 cm away from the sides of the munition. Connect the thermocouples to a central recording facility, and ensure that all thermocouples are reading accurately.

g. Position video or motion-picture sound photographic equipment to record evidence of the reaction. The field of view of at least one of the cameras should be large enough with sufficient resolution to allow a determination of the reaction severity. The photographic equipment should be shielded from the fragment and blast hazard. A video monitor tied into the photography equipment shall be placed in the test control area to view the test item reaction.

h. Photograph and visually inspect the test item.

i. Mount the test item on the support structure in the configuration being duplicated by the test with the centerline of the test item 91 cm above the intended surface of the fuel. Insulate the test item from the support structure to alleviate any undesirable heat paths through the support structure to the test item.

j. Activate and reset all instrumentation, including photographic and temperature measurement equipment.

k. Pour the hydrocarbon fuel (JP-4, JP-5, or an equivalent type which will furnish an adequate flame temperature) into the fuel pan.

l. Photograph the test site.

m. Evacuate all personnel not involved in placing the ignition mechanism to an approved safe position.

n. Set the ignition mechanism and evacuate all personnel to the test control area.

o. Remotely trigger the ignition mechanism and begin recording temperature measurements from the test control area. While the test is conducted, record each thermocouple measurement once every second.

p. After the test item reaction, observe a waiting period as determined in the appropriate Standing Operating Procedure (SOP) before inspecting the test site.

q. Inspect and photograph the test item remains. Make a preliminary estimate of the reaction severity, document the location of the test item components, and if appropriate and safe, collect all significant post-test remains for measurement of fragment size and weight.

r. Repeat steps h through q when the fuel pan and surrounding area has cooled to ambient conditions.

#### 4.2.4 Data Required.

a. Lot number and stock number of each test item.

b. A description of the test setup (including type of fuel) and a narrative of test events.

c. Weather conditions including prevailing wind speed.

d. Type of reaction (if any) based on criteria in Appendix B, and the associated fragment sizes and spatial distribution as specified in Appendix C.

e. Time to reach 538 °C (1000 °F) for each of the thermocouples.

f. Video or photographic record of the test item reaction.

g. Still photographs of the test item and test site before and after (if applicable) the cook-off event.

#### 4.2 Slow Cook-off Test.

The purpose of the slow cook-off test is to record the test item response due to a gradually increasing change (3.3 °C per hour) in temperature. A controlled, uniform, thermal environment is created by enclosing the test item in an oven-like chamber.

#### 4.3.1 Test Site.

The test site shall include an appropriate size conditioning chamber to accommodate the test item and at least 20 cm of air between the largest dimensions of the test item and the inner wall of the conditioning chamber. Design of the chamber shall minimize deviations from a uniform temperature distribution within the conditioning chamber, and shall ensure that secondary reactions (such as those associated with exudation contacting the heat source) do not occur. The conditioning chamber shall also provide for relief of the increased internal air pressure within it due to heating. The materials selected for the conditioning chamber design shall confine the test item and air within it, but should minimize confinement of the test item reaction. It may also be desirable to install viewing portals in the walls of the conditioning chamber to record reaction events and to provide for remote view of the test item. Some type of support structure shall be placed inside the conditioning chamber to suspend the item in the center of the chamber, and to keep the test item from contacting the heat source. However, this support structure shall neither greatly affect the temperature distribution around the test item, nor alter the violence of the reaction. If the test item contains a rocket motor, the item shall be restrained with fixtures to avoid launching due to a propulsive reaction. A witness plate shall be positioned beneath the test item to provide evidence of a test item reaction. Night lighting and rain protection is recommended due to the expected duration of the slow cook-off test.

#### 4.3.2 Required and Suggested Instrumentation.

A minimum of four thermocouples shall be installed along a horizontal plane passing through the center of the test item inside the conditioning chamber to measure air temperature (see fig. 1). The thermocouples (1, 2, 3, and 4 shown in fig. 1) shall be installed on the plane at 90-degree intervals at 10 cm from each conditioning chamber wall. Either thermocouple 1 or 2 shall be used as the thermocouple for oven control. Two additional thermocouples are suggested for installation above and below the center of the test item, 10 cm from the inside wall of the top and bottom of the conditioning chamber. To measure the test item skin temperature up to the time of reaction, at least two thermocouples (5 and 6 shown in fig. 1) shall be secured to the test item surface. Permanent-record temperature-recording devices shall be used to record the temperature measured by each thermocouple at least once per minute. Video or motion-picture sound photography shall be used to record the reaction of the test item.

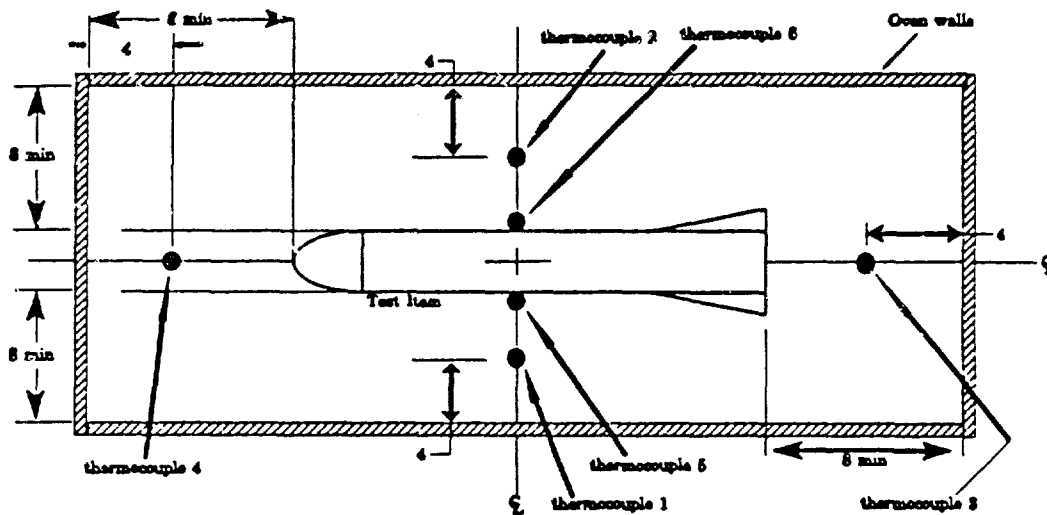

Figure 1. Exterior thermocouple placement for the slow cook-off test

#### 4.3.3 Method.

a. By consulting engineering design drawings of the test item, determine the largest dimensions of the test item. Design and build a conditioning chamber at least 20 cm larger than the corresponding maximum dimensions of the test item.

b. Determine the correct configuration of the test item in the logistical life-cycle phase being duplicated by the test. Design a support structure to hold the test item in the center of the conditioning chamber. If the test item contains a rocket motor or propulsive device, design and build an appropriate restraining device or stopping structure to contain the test item or the entire oven structure if a propulsive reaction occurs during the slow cook-off test.

c. Design and build a catch basin to prevent exudate from contacting the heat source.

d. Attach at least two thermocouples to the external surface of the test item. If temperatures are to be recorded inside the test item, insert the required thermocouples into the test item, minimizing any changes to the test item or configuration.

e. Select a suitable test area, as level as possible for the placement of the conditioning chamber. The test site should include an appropriate danger zone to accommodate a detonation reaction. The test site shall also include an area designated as the test control area. The test control area shall function as the safe area for personnel to view the reaction of the test item.

f. If deemed necessary to decrease the overall duration of the cook-off test, the test item may be preconditioned for eight hours before the start of the test in a temperature chamber to the maximum operating temperature expected to be encountered during the life cycle of the test item.

g. Position the test item support structure on the test site so as to position the test item at least 20 cm from any inside wall of the conditioning chamber. Place a witness plate directly beneath the test item support structure to record the reaction of the test item. Place the catch basin under the intended position of the test item.

h. Position at least four thermocouples 10 cm from the outside of the ordnance skin with one thermocouple on each end and side of the intended position of the test item in a horizontal plane passing through the item's centerline. Connect the thermocouples to a central recording facility, and ensure that all thermocouples are reading accurately.

i. Photograph and visually inspect the test item.

j. Mount the test item on the support structure in the configuration being duplicated by the test. Insulate the test item from the support structure to alleviate any undesirable heat paths through the support structure to the test item.

k. Place the test item and support structure inside the conditioning chamber. All thermocouple wires should exit the conditioning chamber in such a way as to minimize any possible heat loss.

l. Position video or motion-picture sound photographic equipment to record evidence of test item reaction. The field of view of at least one of the cameras should be large enough to view the entire test site for a possible determination of the reaction severity. The photographic equipment should be shielded from the fragment and blast hazard. Video coverage of the interior of the conditioning chamber is suggested during the slow cook-off test. Video monitors tied into the photographic equipment shall be placed in the test control area to view the reaction of the test item.

m. Activate and reset all instrumentation, including photographic and temperature measurement equipment.

2 June 1993

n. Assure that the conditioning chamber controls are properly set.

o. Photograph the test site.

p. Activate the conditioning chamber and begin recording temperature measurements from the test control area. The conditioning chamber may be quickly heated to the test item's maximum operating temperature. While the test is conducted, record each thermocouple measurement at least once every minute until the test is completed. Using the video system, record the reaction of the test item.

q. After the test item reaction, observe a waiting period as determined in the appropriate SOP before inspecting the test site.

r. Inspect and photograph the test item remains. Make a preliminary estimate of the reaction severity, document the location of the test item components, and if appropriate and safe, collect all significant post-test remains for measurement of fragment size and weight.

s. Repeat steps d through r for the second test item.

#### 4.3.4 Data Required.

a. Lot number and stock number of each test item.

b. A description of the test setup and a narrative of test events.

c. Type of reaction (if any) based on criteria in Appendix B, and the associated fragment sizes and spatial distribution as specified in Appendix C.

d. Chamber and test item time-temperature data to reaction measured by each temperature sensor.

e. Still photographs of witness plate damage.

f. Video or photographic record of the test item reaction.

g. Still photographs of the test item and test site before and after the cook-off event.

#### 4.4 Bullet-Impact Test.

The purpose of the bullet-impact test is to determine the reaction of the test item when impacted by three bullets. Unless specified otherwise, the three bullets used will be .50 caliber (U.S. type M2) armor-piercing (AP) bullets at a velocity of  $853 \pm 61$  m/sec ( $2800 \pm 200$  ft/sec). The three bullets shall be fired sequentially at  $50 \pm 10$  millisecond (ms) intervals. If one weapon is used to fire the three bullets, the use of the weapon service rate of 100 ms is acceptable. For items of caliber 40 mm and less, the single item should be replaced with a fully loaded logistical package for the two tests.

#### 4.4.1 Test Site.

The test site shall include the appropriate caliber gun and mounting fixture. Steel witness plates shall be positioned beneath the test item to serve as evidence of reaction. Appropriate fixtures to restrain the test item must be provided to ensure that if a reaction occurs, the fixtures reduce the hazards from the reaction to a minimum with respect to adjacent facilities and populated areas without altering the violence of the reaction. Protection should be made available for all operational personnel and is suggested for the guns and mounting fixtures.

#### 4.4.2 Required and Suggested Instrumentation.

At least one type of the following photographic evidence is required to record the test item response: high-speed motion-picture photography, motion-picture sound photography, or video. The field of view shall be large enough to allow full view of the reaction, and the resolution shall be clear enough to discern which type of reaction (if any) occurs. To further aid in the determination of reaction type, airblast overpressure gages may be used. The gages shall be calibrated to record the peak pressure expected from the detonation of the test item. Frequency response of the gages should be such that if the test item detonates, the entire pressure history may be followed. The bullet-impact velocity shall be measured using any appropriate method accurate to within 15 m/sec.

#### 4.4.3 Method.

a. By consulting engineering design drawings of the test item, determine the locations of largest explosive content, and highest sensitivity. The test item configuration shall duplicate the configuration as it would be encountered in the life cycle phase being duplicated by the test.

b. Select the appropriate impact munition in accordance with the THA. By default, this impact threat will be .50-caliber (type M2) armor-piercing (AP) bullets at a velocity of  $853 \pm 61$  m/sec.

c. Select a suitable test area, as level as possible and without obstructions, with room for an adequate safety zone behind the target for the maximum range of the impact threat.

d. Place photographic equipment in position to record evidence of reaction of the test item. The field of view of at least one of the cameras should be large enough and with sufficient resolution to allow a determination of the reaction severity. Regular-speed video is suggested to obtain an overall view of the test area while testing is conducted.

e. Position a fragment shield in front of the weapon position to protect the weapon from any fragment hazard if the test item should detonate.

f. Set up, calibrate, and position the velocity measurement devices that have been selected to record the impact velocities.

g. Secure the correct caliber weapon(s) in the mounting fixture(s), and align and synchronize the weapon(s) to be fired during testing.

h. Activate and reset all instrumentation, including photographic and velocity measurement equipment.

i. Fire three rounds at firing intervals of  $50 \pm 10$  milliseconds to ascertain whether the instrumentation is functional and the impact velocities are within the required range. If the velocities are not within the required range, the setup must be altered and steps f through i repeated until the velocities are within the prescribed limits. It may be useful to use an inert target round during these preliminary firings to determine if the accuracy is being maintained.

j. Photograph and visually inspect the test item.

k. Position witness plates below the test item to furnish evidence of reaction of the test item.

l. Secure the test item to a fixture.

m. If the test item configuration includes a launch tube, or shipping container, it may be desirable to simulate the container using flat target plate of the same material and thickness. Paint or place a circle and crossbar target on each target plate, or on the outside surface of the test item for weapon aiming purposes.

n. Reset all instrumentation (including velocity measurement, photographic, and blast overpressure (if used)) and perform an operational check on all instrumentation.

o. Fire three rounds at a firing interval of  $50 \pm 10$  milliseconds at the location of the test item's largest explosive content.

p. After the 3-round burst, observe a waiting period as determined in the appropriate SOP before inspecting the test item.

q. If applicable, inspect the test item, mark the point of impact, and take still photographs of the test item. If the test item has reacted, make a preliminary estimate of the reaction severity, document the location of the test item components, and if appropriate and safe, collect all significant post-test remains for measurement of fragment size and weight.

r. Repeat steps j through q for the most sensitive location on the second test item.

#### 4.4.4 Data Required.

- a. Lot number and stock number of each test item.
- b. Type, lot number, and stock number of the impact munition.
- c. A description of the test setup (including the location of all airblast overpressure gages), and a narrative of test events.
- d. Bullet velocity at the point of impact.
- e. Type of reaction (if any) based on criteria in Appendix B, and the associated fragment sizes and spatial distribution as specified in Appendix C.
- f. The airblast overpressure data collected (including the peak pressure, and time-to-peak pressure of the test item if it detonates).
- g. Still photographs, location, and written description of the damage to witness plates.
- h. Video or photographic record of the reaction of the test item.
- i. Still photographs of the test item before and after impact.

#### 4.5 Fragment-Impact Test.

Two standard fragment-impact tests have been developed to assess the reaction of a munition when impacted by a fragment. For items fielded only by the U.S. Army, the first test (endorsed by the U.S. Army Insensitive Munitions Office in the U.S. Army Supplement to MIL-STD-2105A) launches a single conical-shaped, mild-steel, 250-grain 12.7-mm (0.5-in.) diameter fragment (see fig. 2) at 1829 m/s (6000 ft/s) at the munition. For test items fielded both by the U.S. Army and U.S. Marine Corps or U.S. Navy, the second fragment impact test (specified by MIL-STD-2105A) launches at least two but no more than five 12.7-mm cubic, 250 grain, mild-steel fragments with a striking velocity of  $2530 \pm 91$  m/sec ( $8300 \pm 300$  ft/sec). For the test items used for either fragment-impact test, fragments shall impact at least one in the most shock-sensitive location, and at least one in the portion of the test item containing the largest amount of explosive material.

##### 4.5.1 Test Site.

The test site shall include the appropriate fragment projection mechanism and test item mounting fixture. Steel witness plates shall be positioned beneath the test item to serve as evidence of reaction. To record the number of fragments impacting the test item, it may be necessary to place witness plates behind the test item. Appropriate fixtures to restrain the test item must be provided to ensure that if a reaction occurs, the fixtures reduce the hazards from the reaction to a minimum with respect to adjacent facilities and populated areas without altering the violence of the reaction. Protection should be made available for all operational personnel and is suggested for instrumentation.

# THE IM FRAGMENT TEST CONICAL FRAGMENT

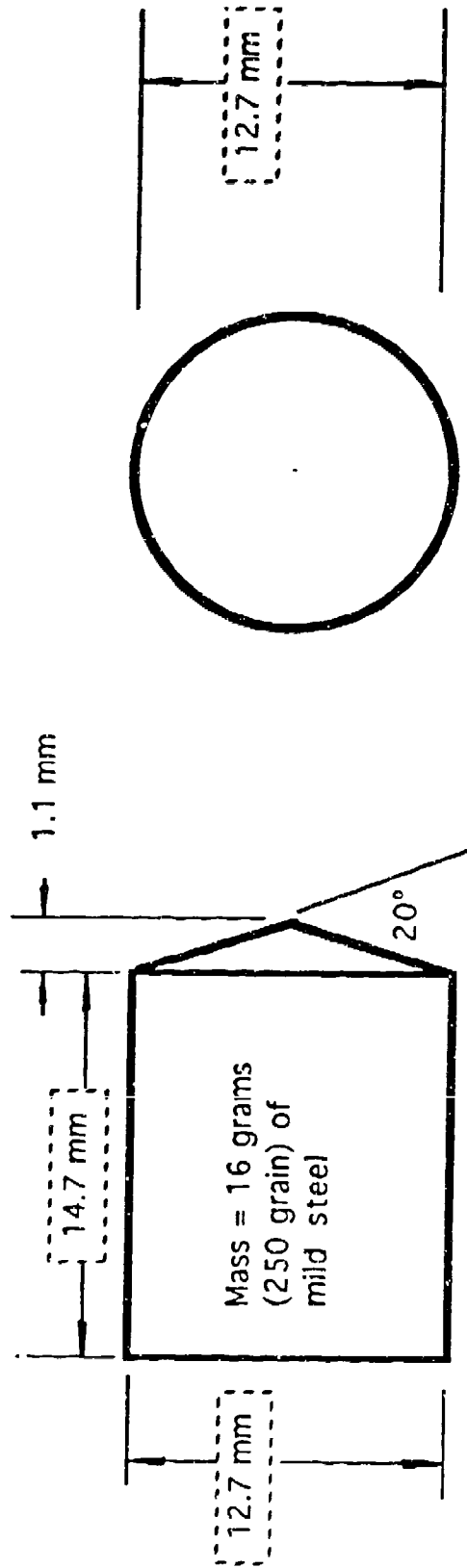

Figure 2.

#### 4.5.2 Required and Suggested Instrumentation.

At least one type of the following photographic evidence is required to record the test item response: high-speed motion-picture photography, motion-picture sound photography, or video. The field of view shall be large enough to allow full view of the reaction, and the resolution shall be clear enough to discern which type of reaction (if any) occurs. To further aid in the determination of reaction type, airblast overpressure gages may be used. The gages shall be calibrated to record the peak pressure expected from the detonation of the test item. Frequency response of the gages should be such that if the test item detonates, the entire pressure history may be followed. The fragment-impact velocity shall be measured using any appropriate method accurate to within 15 m/sec.

#### 4.5.3 Method.

a. By consulting engineering design drawings of the test item, determine the locations of largest explosive content, and highest sensitivity. The test item configuration shall duplicate the configuration as it would be encountered in the item's life cycle phase.

b. Obtain test item simulators of the same presented area and general shape as the test item. These simulators will be placed in the same location along the fragment line-of-fire as the test item will assume during the test.

c. Select a suitable test area, as level as possible and without obstructions, with room for an adequate safety zone behind the target for the maximum range of the projected fragment(s).

d. Position a test item simulator in the proposed test item location. Position a thin witness plate behind the test item simulator to record the striking pattern of the steel fragment(s).

e. Align the fragment projecting mechanism to impact the proposed impact location of the test item simulator. Prepare an appropriate velocity measurement system to record the impact velocity of the fragment(s). Evacuate all personnel not involved in activating the fragment projecting mechanism to appropriate safety areas.

f. Prepare the fragment projecting mechanism, activate the velocity measurement system and evacuate all personnel to an appropriate safety area.

g. Activate the fragment projecting mechanism.

h. Inspect and photograph the test item simulator, mark and record the number of points of impact, and record the impact velocity of the fragment(s). From these data determine the adequacy of the test simulation in terms of number of impacts and fragment velocity requirements.

i. Repeat steps d through h until sufficient information is available to ensure that the correct number of fragments will impact the test item, and the velocity requirement will be met when the test item is substituted for the simulators.

j. Position a witness plate directly beneath the proposed test item location to provide evidence of test item reaction. A witness plate may also be positioned directly behind the proposed test item position to record the number of fragment impacts.

k. Place photographic equipment in position to record evidence of reaction of the test item. The field of view of at least one of the cameras should be large enough and with sufficient resolution to allow a determination of the reaction severity. Regular-speed video is suggested to obtain an overall view of the test area while testing is conducted.

l. Photograph and visually inspect the test item.

m. Secure the test item to a fixture.

n. Reset all instrumentation (including photographic, and blast over-pressure (if used)) and perform an operational check on all instrumentation.

o. Align the fragment projecting mechanism to impact the largest quantity of explosives. Prepare an appropriate velocity measurement system to record the impact velocity of the fragments. Evacuate all personnel not involved in activating the fragment projecting mechanism to appropriate safety areas.

p. Prepare the fragment projecting mechanism, activate the velocity measurement system and evacuate all personnel to an appropriate safety area.

q. Activate the fragment projecting mechanism.

r. If applicable, inspect and photograph the test item, mark the points of impact, and record the velocity of the impacting fragment(s). If the test item has reacted, make a preliminary estimate of the reaction severity, document the location of the test item components, and if appropriate and safe, collect all significant post-test remains for measurement of fragment size and weight.

s. Repeat steps j through r for the most shock-sensitive location on the second test item.

#### 4.5.4 Data Required.

- a. Lot number and stock number of each test item.
- b. Fragment size, weight, and material type.
- c. A description of the test setup (including the location of all airblast overpressure gages), and a narrative of test events.
- d. Fragment velocity at the point of impact.
- e. Type of reaction (if any) based on criteria in Appendix B, and the associated fragment sizes and spatial distribution as specified in Appendix C.
- f. If airblast overpressure gages are used, the airblast overpressure data collected (including the peak pressure, and time-to-peak pressure of the test item if it detonates).
- g. Still photographs, location, and written description of the damage to witness plates.
- h. Video or photographic record of the reaction of the test item.
- i. Still photographs of the test item before and after (if applicable) impact.

#### 4.6 Sympathetic Detonation Test.

The purpose of the sympathetic detonation test is to determine the reaction of the test item to the detonation of an adjacent donor item of the same type in the life-cycle storage configuration replicated by the test. Another objective of this test is to determine the likelihood that the detonation of one item in a storage stack will propagate to the other items in the stack.

##### 4.6.1 Test Site.

The test site shall include an appropriate range area large enough to safely accommodate the detonation of all test items. The correct number of acceptor munitions, inert simulator munitions (if used), and the donor munition should be available along with the packing materials employed in the storage configuration being simulated in the test. A witness plate may be placed below the test items to record any reaction of the acceptor munitions. Additional witness plates may be placed around the test items as long as they do not modify the fragmentation or blast effects of the donor munition. If a witness plate is not used, high-speed motion-picture cameras (minimum of 32,000 frames per second) shall be mandatory to record the reaction of the test item. To ensure that the reaction is recorded, both witness plates and high-speed motion picture cameras are suggested. The placement of the high-speed motion-picture cameras shall be selected to minimize the

obscuration of the acceptor munition(s) by the expanding gas cloud of the donor munition. An external stimulus may be required to initiate the donor munition. If possible, this stimulus shall simulate the threat most likely to occur in the storage configuration of the test item. By default, the stimulus will be the impact of a 81-mm shaped-charge jet.

#### 4.6.2 Required and Suggested Instrumentation.

Blast overpressure shall be measured. The pressure gages shall be capable of measuring overpressure as a function of time with a minimum frequency response of 20 kHz. At least two groups of four gages shall be used to record overpressure. The two groups shall be placed mutually perpendicular to each other as described in Figure 3. The gages shall be mounted against the ground surface or on elevated fixtures with sensing face parallel to the expected direction of the blast wave. The elevated fixtures should minimize flow disturbance. If high-speed motion-picture cameras are used, the exposure shall be selected to minimize the possibility of washout due to the intense light of the donor detonation. The field of view shall be large enough to allow full view of the reaction, and the resolution shall be enough to discern which type of reaction (if any) occurs.

#### 4.6.3 Method.

a. By consulting the THA for the test item, determine the storage or transport configuration(s) which represent the greatest theoretical threat of sympathetic detonation. If enough test items are available, consider conducting multiple configurations or replications of a single configuration. Taking packaging symmetry into account, determine which items in the selected configuration can be simulated by dummy rounds, and which items in the packaging configuration will represent the donor and the acceptors.

b. Obtain the correct number of dummy rounds for the selected storage configuration(s).

c. Modify each donor munition for static detonation. Minimize any changes to the test item, and attempt to use the test item's intended explosive train.

d. If the test item contains a rocket motor or propulsive device, design an appropriate restraining device or stopping structure to contain the test items or the entire packaging configuration if a propulsive reaction occurs during the sympathetic detonation test.

e. Select a suitable test area. The test site should include an appropriate danger zone to accommodate the detonation of the donor and all acceptor munitions involved in the test.

f. If historical data are unavailable for distances of peak airblast overpressures measured from the test item or an explosive equivalent, conduct a calibration experiment to determine the approximate magnitude of the air shock produced by a test item or the explosive equivalent of the test item. The following sequence shall be followed:

(1) Position pressure gages to measure the air shock produced by the test item or its explosive equivalent. At least eight transducers shall be used. The placement of the transducers shall be in accordance with Figure 3. Mount each transducer flush with the ground surface or elevated above the ground with the sensing face of the transducer parallel to the direction of anticipated air flow from the detonation. If the transducers are elevated, design the transducer mounting fixtures to minimize the amount of air flow disturbance.

(2) Modify one test item or an item of the same explosive equivalence for static detonation.

(3) Place the modified item in the same position as the test items will assume during the actual sympathetic detonation test.

(4) If the test item contains a rocket motor or propulsive device, install the restraining device or stopping structure selected in step d.

(5) Perform an operational test on all transducers and the associated instrumentation.

(6) Evacuate all personnel not involved in enabling the detonation mechanism to a safe position.

(7) Enable the detonation mechanism and evacuate all personnel to a safe position.

(8) Detonate the item. Record all pressure data from the transducers.

(9) From the pressure data, determine the distance from the test item at which the peak airblast overpressure reaches 276, 69, 28, and 7 kPa (40, 10, 4, and 1 psig) if all the test items detonate.

g. Place a witness plate below the intended position of the test items. Place witness plates to the sides and on top of the packaging configuration if desired.

h. Position pressure gages to measure the air shock produced by the test items. The placement of the gages shall be in accordance with Figure 3, using the distances determined in step f. Mount each transducer flush with the ground surface or elevated above the ground with the sensing face of the transducer parallel to the direction of anticipated air flow from the detonation.

i. Position high-speed motion-picture photographic equipment capable of photographing a minimum of 32,000 frames per second to record evidence of reaction of the test item. The field of view of the cameras should be large enough to view the entire test site for a possible determination of the reaction severity. Select the film type and exposure to assure that washout or overexposure of the film does not occur due to the possibility of intense light emitted by the detonation of the test item. Video coverage of the entire test site tied into monitors in the test control area is suggested.

j. Photograph and visually inspect each test item.

k. Place the test items in accordance with the configuration selected in step a.

l. Photograph the assembled configuration.

m. If the test item contains a rocket motor or propulsive device, install the restraining device or stopping structure selected in step d.

n. Perform an operational test on all transducers and the associated instrumentation. Activate all pressure measurement and photography equipment.

o. Evacuate all personnel not involved in enabling the detonation mechanism to a safe position.

p. Enable the detonation mechanism and evacuate all personnel to a safe position.

q. Detonate the item. Record all pressure data from the transducers.

r. After the reaction of the test item, observe a waiting period as determined in the appropriate SOP before inspecting the test site.

s. Inspect and photograph the test item remains and the witness plates. Make a preliminary estimate of the reaction severity, document the location of the test item components, and if appropriate and safe, collect all significant post-test remains for measurement of fragment size and fragment weight.

t. If more than one configuration or a replication of the original configuration is required, repeat steps g through s.

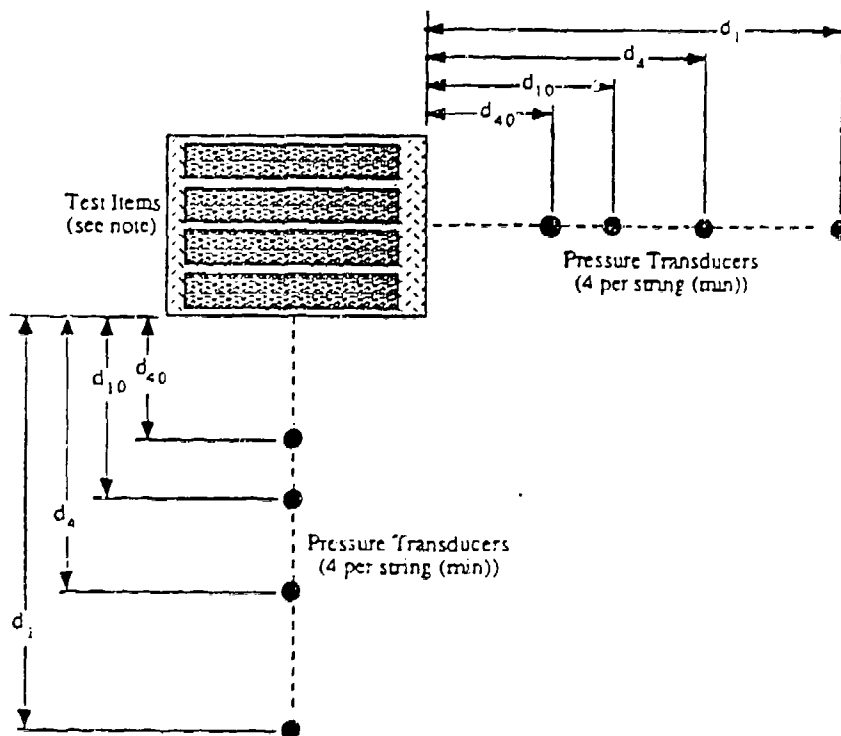

- $d_{40}$  = Distance at which peak airblast overpressure is expected to be approximately 40 pounds per square inch gage (psig) if all test items detonate.
- $d_{10}$  = Distance at which peak airblast overpressure is expected to be approximately 10 psig if all test items detonate.
- $d_4$  = Distance at which peak airblast overpressure is expected to be approximately 4 psig if all test items detonate.
- $d_1$  = Distance at which peak airblast overpressure is expected to be approximately 1 psig if all test items detonate.

NOTE: For illustrative purposes only; packaging, arrangement of test items, and number and placement of acceptors shall be determined based upon the threat hazard assessment.

Figure 3. Transducer placement for the sympathetic detonation test.

#### 4.6.4 Data Required.

a. Lot number, test item type (donor or acceptor), and stock number of each test item.

b. A description of the test setup (including the location of all airblast overpressure gages), and a narrative of test events.

c. Type of acceptor reaction(s) (if any) based on criteria in Appendix B, and the associated fragment sizes and spatial distribution as specified in Appendix C.

d. If airblast overpressure gages are used, the airblast overpressure data collected (including the peak pressure, and time-to-peak pressure of the test item if it detonates).

e. Still photographs, location, and written description of the damage to witness plates.

f. Video or photographic record of the reaction of the test item.

g. Still photographs of the test items before and after (if applicable) detonation of the donor munition.

#### 4.7 Shaped-Charge-Jet Impact Test.

The purpose of the shaped-charge-jet impact test is to determine the test item response to the impact of a credible shaped charge threat.

##### 4.7.1 Test Site.

The test site shall include the appropriate shaped charge threat and test item fixture. Steel witness plates shall be positioned beneath and on either side of the test item to serve as evidence of reaction. Appropriate fixtures to restrain the test item must be provided to ensure that if a weapons system reaction occurs, the fixtures reduce the hazards from the reaction to a minimum with respect to adjacent facilities and populated areas without altering the violence of the reaction. Protection should be made available for all operational personnel and is suggested for the instrumentation.

##### 4.7.2 Required and Suggested Instrumentation.

At least one type of the following photographic evidence is required to record the test item response: high-speed motion-picture photography, motion-picture sound photography, or video. The field of view shall be large enough to allow full view of the reaction, and the resolution shall be clear enough to discern which type of reaction (if any) occurs. To further aid in the determination of reaction type, airblast overpressure gages may be used. The gages shall be calibrated to record the peak pressure expected from the detonation of the test item. Frequency response of the gages should be such that if the test item detonates, the entire pressure history may be followed.

4.7.3 Method.

a. By consulting engineering design drawings of the test item, determine if any cavities in the energetic material exist. If there are cavities, choose the impact location such that the shaped charge passes through the largest cavity. Otherwise, determine the impact location such that the shaped charge passes through the greatest amount of explosive material. The test item configuration shall duplicate the configuration as it would be encountered in the life cycle phase being duplicated by the test.

b. Select the appropriate impact munition in accordance with the THA. By default, for U.S. Army munitions, this impact threat will be the 50 mm Rocket top-attack, shaped charge.

c. Select a suitable test area, as level as possible and without obstructions, with room for an adequate safety zone behind the target for the maximum range of the impact threat.

d. Place photographic equipment in position to record evidence of reaction of the test item. The field of view of at least one of the cameras should be large enough and with sufficient resolution to allow a determination of the reaction severity. Regular-speed video is suggested to obtain an overall view of the test area while testing is conducted.

e. Photograph and visually inspect the test item.

f. Position witness plates below and to each side of the test item to furnish evidence of reaction of the test item.

g. Secure the test item to a fixture.

h. Reset all instrumentation (including photographic, and blast over-pressure (if used)) and perform an operational check on all instrumentation.

i. Align the shaped charge to impact the test item in the location selected in step a, at the correct standoff (if required). Evacuate all personnel not involved in activating the detonation mechanism to appropriate safety areas.

j. Connect the detonation mechanism for the shaped charge and evacuate all personnel to an appropriate safety area.

k. Activate the detonation mechanism. After detonation of the shaped charge, observe a waiting period as determined in the appropriate SOP before inspecting the test item.

1. If applicable, inspect the test item, mark the point of impact, and take still photographs of the test item. If the test item has reacted, make a preliminary estimate of the reaction severity, document the location of the test item components, and if appropriate and safe, collect all significant post-test remains for measurement of fragment size and weight.

m. Repeat steps e through l for the second test item.

#### 4.7.4 Data Required.

a. Lot number and stock number of each test item.

b. Shape charge type, lot number, and stock number of the impact munition.

c. A description of the test setup (including the location of all airblast overpressure gages), and a narrative of test events.

d. Type of reaction (if any) based on criteria in Appendix B, and the associated fragment sizes and spatial distribution as specified in Appendix C.

e. The airblast overpressure data collected (including the peak pressure, and time-to-peak pressure of the test item if it detonates).

f. Still photographs, location, and written description, of the damage to witness plates.

g. Video or photographic record of the reaction of the test item.

#### 4.8 Spall-Impact Test.

The purpose of the spall-impact test is to determine the bare test item response to the impact of hot spall fragments. The hot spall fragments simulate the attack on enclosures surrounding the test item by various penetrating threats. The spall fragments produced for this test are created by penetrating a 25-mm rolled-homogeneous armor (RHA) plate with a shaped charge jet of an 81-mm precision shaped charge at a standoff distance of 14.7 cm. The shaped charge shall be positioned so only spall fragments shall impact the test item.

##### 4.8.1 Test Site.

The test site shall include the appropriate fixtures to support the RHA and witness plates, shaped charge, and test item. Appropriate fixtures to restrain the test item must be provided to ensure that if a reaction occurs, the fixtures reduce the hazards from the reaction to a minimum with respect to adjacent facilities and populated areas without altering the violence of the reaction. To limit the impacting fragments to only those from the RHA plate, a shielding plate may be necessary to stop 81-mm precision shaped charge shell body fragments from impacting the test item. The placement of the test item behind the RHA and shielding plates should be selected so the shaped charge

jet does not impact any portion of the test item, and is impacted by a minimum of four spall fragments/64.5 cm<sup>2</sup> (10 in.<sup>2</sup>) of the test item's presented area. Protection should be made available for all operational personnel and is suggested for the instrumentation.

#### 4.8.2 Required and Suggested Instrumentation.

At least one type of the following photographic evidence is required to record the test item response: high-speed motion-picture photography, motion-picture sound photography, or video. The field of view shall be large enough to allow full view of the reaction, and the resolution shall be clear enough to discern which type of reaction (if any) occurs.

#### 4.8.3 Method.

- a. Calculate the amount of area presented by the test item's bare configuration to the spall.
- b. Obtain test item simulators of the same presented area and general shape as the test item. These simulators will be placed at various locations behind the spall producing plate to calibrate the test setup for the required fragment areal-hit-density of four spall impacts/64.5 cm<sup>2</sup> of test item presented-area.
- c. Select a suitable test area, as level as possible and without obstructions, with room for an adequate safety zone behind the target for the maximum range of the 81-mm precision shaped charge.
- d. Position the 25-mm RHA spall producing plate along with the shielding plate vertically at 14.7 cm from the intended fixture position for the shaped charge and perpendicular to the shaped charge line-of-fire. Position the test item simulators at various distances away from the spall producing plate, and various distances from the shaped charge line-of-fire. Record each simulator's distances to the shaped charge line-of-fire and to the back side of the shielding plate.
- e. Align the shaped charge to impact the center of the spall producing plate at a standoff of 14.7 cm from the surface of the spall producing plate. Evacuate all personnel not involved in activating the detonation mechanism to appropriate safety areas.
- f. Connect the detonation mechanism for the shaped charge and evacuate all personnel to an appropriate safety area.
- g. Activate the detonation mechanism. After detonation of the shaped charge, observe a waiting period as determined in the appropriate SOP before inspecting the test item.

h. Inspect the test item simulators, mark and record the number of points of impact on each simulator, and photograph each simulator. From these data determine the areal-hit-density of each simulator.

i. Repeat steps d through h until sufficient information is available to ensure that a spall areal-hit-density of four spall fragments/64.5 cm<sup>2</sup> (10 in.<sup>2</sup>) will be obtained when the test item is substituted for the simulators.

j. Position the 25-mm RHA spall producing plate along with the shielding plate vertically at 14.7 cm from the intended shaped charge fixture position and perpendicular to the shaped charge line-of-fire. Position the test item at the distance from the back side of the shielding plate and the distance from the shaped charge line of fire selected in step i which provides the correct spall areal-hit-density.

k. Place photographic equipment in position to record evidence of reaction of the test item. The field of view of at least one of the cameras should be large enough and with sufficient resolution to allow a determination of the reaction severity. Regular-speed video is suggested to obtain an overall view of the test area while testing is conducted.

l. Photograph and visually inspect the test item.

m. Secure the test item to a fixture.

n. Reset all instrumentation (including photographic and blast over-pressure (if used)) and perform an operational check on all instrumentation.

o. Align the shaped charge to impact the center of the spall producing plate at a standoff of 14.7 cm from the surface of the spall producing plates. Evacuate all personnel not involved in activating the detonation mechanism to appropriate safety areas.

p. Connect the detonation mechanism for the shaped charge and evacuate all personnel to an appropriate safety area.

q. Activate the detonation mechanism. After detonation of the shaped charge, observe a waiting period as determined in the appropriate SOP before inspecting the test item.

r. If applicable, inspect the test item, mark the points of impact, and take still photographs of the test item. If the test item has reacted, make a preliminary estimate of the reaction severity, document the location of the test item components, and if appropriate and safe, collect all significant post-test remains for measurement of fragment size and weight.

s. Repeat steps j through r for the remaining test item(s).

#### 4.8.4 Data Required.

The results of the calibration test(s) for the correct spall areal-hit-density shall be provided. Additionally, for each spall-impact test, record the following:

- a. Lot number and stock number of each test item.
- b. Shape charge type, lot number, and stock number of the impact munition.
- c. A description of the test setup, and a narrative of all test events.
- d. Type of reaction (if any) based on criteria in Appendix B, and the associated fragment sizes and spatial distribution as specified in Appendix C.
- e. If the test item can be approached safely, record the number of perceptible spall impacts.

#### 5. PRESENTATION OF DATA.

a. Assemble and tabulate all results and safety related information generated during the tests conducted in accordance with this TOP. Assign a preliminary explosive-reaction level for each item involved in each test. Classify each reaction as to whether it would occur during storage, transportation, handling, maintenance, use, or some combination thereof. Develop a narrative of all hazards identified and recommended actions required to eliminate or avoid each potential hazard.

b. Derive counts of actual hazardous events, along with related test events/cycles and/or times when no safety related problems occurred. This will allow calculation of hazard rates and probabilities using statistical methods. The Test Design Plan and the Independent Assessment/Evaluation Plan should provide guidance on the appropriate statistical methods.

c. Justify any actions taken which deviate from the instructions of this TOP or MIL-STD-2105A. Cite actions taken by the appropriate review organizations to reinforce decisions to deviate from this TOP.

TOP 4-2-025

2 June 1993

d. Include photographs, video coverage, and high-speed film with the test report to support the classification of reaction levels.

Recommended changes of this publication should be forwarded to Commander, U.S. Army Test and Evaluation Command, ATTN: AMSTE-CT-T, Aberdeen Proving Ground, MD 21005-5055. Technical information can be obtained from the preparing activity; Commander, U.S. Army Combat Systems Test Activity, ATTN: STECS-DA-ID, Aberdeen Proving Ground, MD 21005-5059. Additional copies are available from the Defense Technical Information Center, Cameron Station, Alexandria, VA 22304-6145. This document is identified by the accession number (AD No.) printed on the first page.

## APPENDIX A

### HISTORICAL INFORMATION ON INSENSITIVE MUNITIONS (IM) TESTING

The idea behind designing ordnance items has always been to place a highly volatile material in the presence of a designated threat to render the threat inoperable. Most materials (high explosive fills, propellants, primers, actuators, etc.) require only a small stimulus in the intended position to trigger a violent reaction capable of destroying anything from the human body to concrete bunkers. Storing and transporting explosives in a safe manner has always been one of the most challenging tasks for the armed services. One method to combat this challenge is to design better forms of storage and safer forms of transportation. The emphasis of the IM program is to approach the problem from its source by designing weapon systems to react only when intended.

The IM program is a direct result of various accidents involving munitions. The largest of these accidents in the post-World War II era have been related to shipboard fuel fires on aircraft carriers. One accident on the USS Forrestal in 1967 resulted in 134 dead and 161 injured (ref a, app D). Not only did this accident point out the losses in human life, but substantial functional, monetary and materiel losses were also incurred. The U.S. Navy first started testing ordnance items for sensitivity to fast cook-offs due to these types of accidents. The fast cook-off test was one of the elements provided in U.S. Navy document WR-50, which in 1982 evolved into the first version of MIL-STD-2105.

In the early 1980s, the Department of Defense explored the possibility of adding the Insensitive Munitions program to the life cycle testing of munition systems. MIL-STD-2105 was used as a baseline for the types of tests and evaluation criteria. MIL-STD-2105 contained provisions for the 28- and 4-day temperature-and-humidity tests, vibration test, slow and fast cook-off tests, and the bullet-impact test. Since 1982 four core tests have been added to conform with the DOD policy on Insensitive Munitions. All non-nuclear munitions which will be produced after 1993 are required to undergo all 11 of the core tests. A discussion of the historical significance of each of the tests follows.

a. The four basic safety tests (28-day temperature-and-humidity, vibration, 4-day temperature-and-humidity, and 12-meter (40-ft) drop test) are typically performed on weapon systems, but usually after the test item undergoes one of these tests, it is functionally tested or destroyed. The radiographic and visual inspections performed between these tests are critical in assessing the damage produced by each of the environmental stimuli.

b. The fast cook-off test simulates a fuel fire similar to the one on the USS Forrestal. Typically the fuel is ignited by pouring approximately 19 liters (5 gal.) of gasoline, and remotely initiating thermite grenades in the four corners of the fuel pan. As a general rule of thumb, 5 cm of JP-5 fuel burns for about 5 minutes. Due to the need for oxygen for burning the fuel, this test should never be conducted on a day when the breeze is completely still if no equipment is used to feed oxygen to the fire.

c. The slow cook-off test simulates a slowly increasing temperature environment such as that experienced in storage. Some test centers have used oven structures, or an intervening medium between the test item and the heat source (ref b, app D). Generally, commercially available heater bands are used for the heat source, tied into a controller mechanism which monitors the internal oven temperatures. Previous testing methodologies allowed the test item to be preconditioned to a temperature 56 °C (100 °F) less than the expected cook-off temperature. This is no longer a valid practice.

d. The bullet-impact test is very dependent on the selection of the impact threats of the THA. Previously, the projectile with the highest energy impact in the THA was selected as the bullet for impact. Results by Milton and Thorn (ref c, app D) suggest that higher velocity, lower caliber projectiles may present the maximum threat of bullet impact sensitivity. The selection of the most shock-sensitive location also requires forethought. A typical bullet-impact test set-up is shown in Figure A-1.

e. Two methodologies exist for projecting fragments in the fragment-impact test. The first involves detonating a block of high explosive behind a scored block of mild steel. The second method is to fire the fragments from a gun barrel and encasing the steel fragment in a sabot. Difficulties can arise in both methods. The large amount of explosive used in the first method is usually required to be poured into a mold. If the correct velocities are not obtained, the explosive must be machined into a smaller size or repoured. The current version of MIL-STD-2105A requires between two and five fragments to impact the test item at the same time. In the second method, at least two gun barrels would have to be used, firing synchronously and projecting the fragments at the same velocity.

f. The results of the sympathetic detonation test are dependent on the selection of the location of the donor and acceptor munitions. Ideally, all the items in the packaging configuration should be live rounds. The number of rounds required can be reduced by taking symmetrical packing into consideration. Do not assume that the most violent reactions will occur in the rounds closest to the donor item.

2 June 1993

g. The shaped-charge-jet impact test is the IM test with probably the highest energy transfer to the munition under test, and is one of the most severe threat environments to a munition in a forward storage area or within a vehicle. Almost all current high explosives will detonate when exposed to this threat. The shaped charge's capability to penetrate packaging and continue through shell bodies, and starting fires in flammable materials make it an extremely challenging hazard to mitigate. The U.S. Army Supplement to MIL-STD-2105A recommends that the shaped-charge-jet impact test only be required for impacting propellants and propulsion systems.

h. The spall impact test is very similar to the shaped-charge-jet impact test, but the threat to the munition is the very hot spall fragments produced by the impact of a shaped-charge on vehicle armor or protective plates in a ammunition supply vehicle. It is conceivable that a shaped charge can enter and exit a vehicle without impacting an ammunition item, and yet the spall fragments produced from the impact ignite or detonate the ammunition contained within the vehicle.

Many other environmental hazard tests are available to assess the sensitivity of a given test item to the realistic hazards which will occur during the item's life cycle. A number of additional tests are listed in MIL-STD-2105A. These tests may need to be taken into account for full and realistic hazards testing.

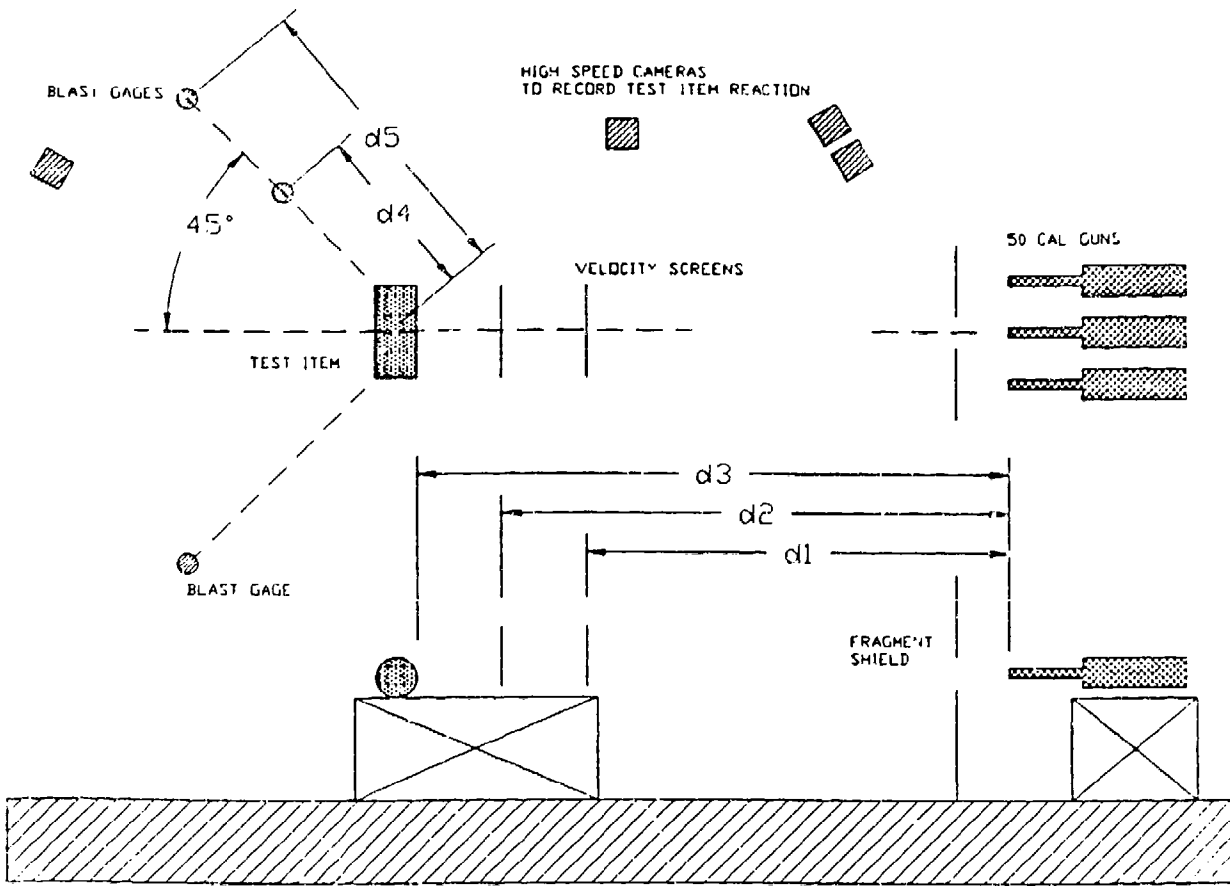

NOTES

- $d_1$  = DISTANCE TO FIRST VELOCITY SCREEN
- $d_2$  = DISTANCE TO SECOND VELOCITY SCREEN
- $d_3$  = DISTANCE TO TEST ITEM
- $d_4$  = DISTANCE TO FIRST BLAST GAGE
- $d_5$  = DISTANCE TO SECOND BLAST GAGE(S)

Figure A-1. Typical Bullet-Impact Test setup.

## APPENDIX B

### DETERMINING THE TYPE OF REACTION

Identifying the type of reaction is based on the definitions provided in MIL-STD-2105A. These definitions are listed below, and ranked in order from most to least violent. It may be difficult to determine a preliminary estimate of the reaction to a specific test due to similarity between some of these definitions. For instance, there is potentially little difference between the partial detonation, explosion, and deflagration reactions. Figure B-1 can be used as a guide to selecting the appropriate reaction type. The ultimate decision will be made by the appropriate review organization. Therefore, it is very important to justify the determination of the reaction severity with as much evidence as can be made available to the review organization.

Detonation Reaction (Type I). The most violent type of explosive event. A supersonic decomposition reaction propagates through the energetic material to produce an intense shock in the surrounding medium. This is accompanied by a very rapid plastic deformation of metallic cases, followed by extensive fragmentation. All energetic material will be consumed during the reaction. The effects will include large ground craters for munitions on or close to the ground, holing or fragmentation of adjacent metal plates, and blast overpressure damage to nearby structures.

Partial Detonation Reaction (Type II). This reaction is similar to the detonation reaction, but only some of the energetic material reacts during the detonation. Effects and damage to surrounding structures will be similar to the detonation reaction, but will depend on the portion of material that detonates. A partial detonation can also produce large case fragments as in a violent pressure rupture.

Explosion Reaction (Type III). Ignition and rapid burning of the confined energetic material builds up high local pressures leading to violent pressure rupturing of the confining structure. Metal cases are fragmented into large pieces that are often thrown long distances. Unreacted and/or burning energetic material is also thrown about. Fire and smoke hazards will exist. Air shocks are produced. The blast and high velocity fragments can cause minor ground craters and damage to adjacent metal plates. Blast pressures will be lower than for a detonation.

Deflagration Reaction (Type IV). Ignition and burning of the confined energetic materials leads to nonviolent pressure release as a result of a low strength case or venting through case closures. The case might rupture but does not fragment. Closure covers might be expelled, and unburned or burning energetic material may be thrown about and spread the fire. Pressure venting can propel an unsecured test item. No blast is noticed. Only damage due to smoke and heat to the surroundings is noticed.

Burning Reaction (Type V). The energetic material ignites and burns, nonpropulsively. The case may open, melt, or weaken sufficiently to rupture nonviolently, allowing mild release of combustion gases. Debris stays mainly within the area of the fire. This debris is not expected to cause fatal wounds to personnel or be a hazardous fragment beyond 15 meters.

Propulsive Reaction (Type VI). A reaction whereby adequate force is produced to impart flight to the test item in its least-restrained configuration as determined by the life-cycle analysis.

No Reaction (Type VII). No propulsive, burning, pressure release, or detonation results due to the test stimulus. Damage may be noticed due to impact, vibration, or heat and smoke.

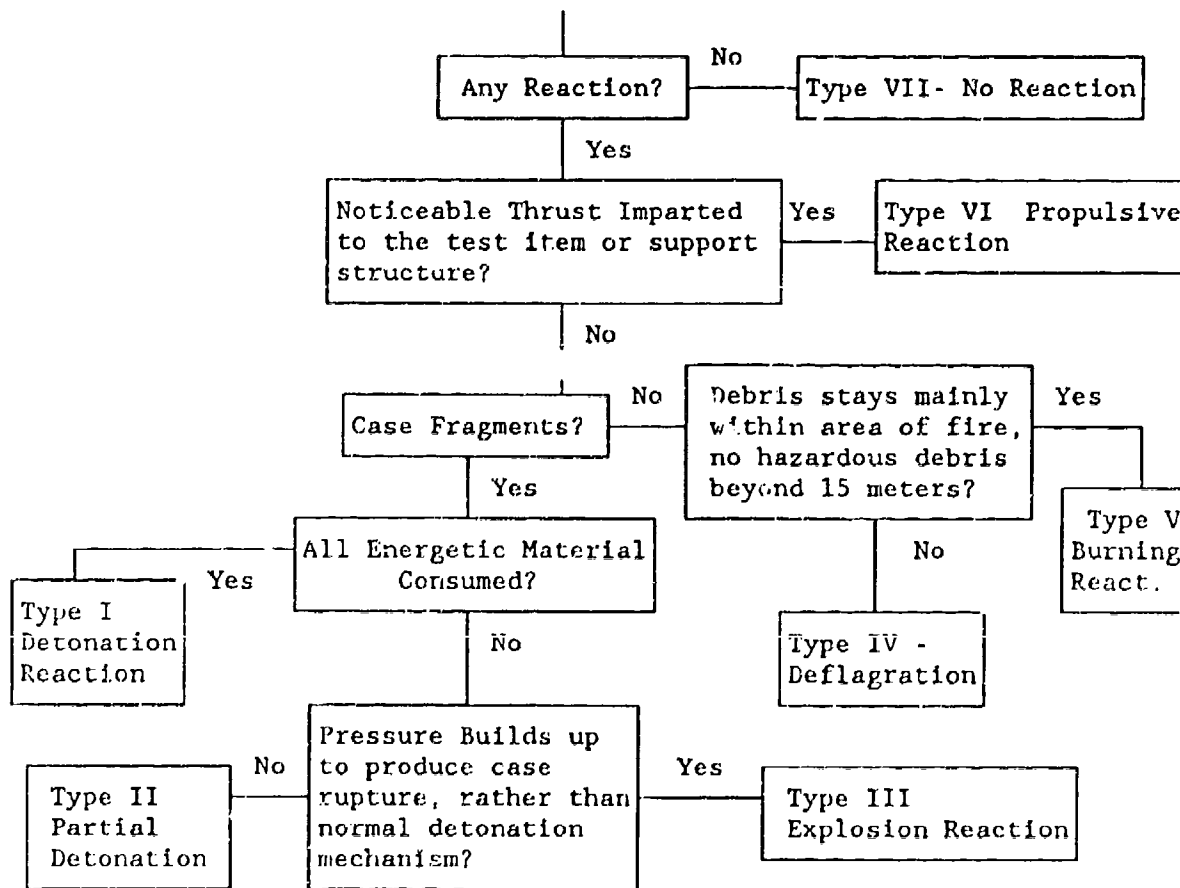

Figure B-1. Decision tree for reaction types.

APPENDIX C

COMPLETING THE POST-TEST REMAINS MAP AND TABULATION CHART

Completing the post-test remains map and tabulation chart is a method to quickly and easily document the results of any of the insensitive munitions tests. It also lends evidence in determining the type of reaction after any of the tests.

As fragments are collected immediately after the reaction has occurred, number each fragment. Record the distance from the original test item position, the fragment weight, the polar angle from the longitudinal axis of the test item, and a description of the fragment on the tabulation chart. Each numbered fragment should then be placed on the appropriate area on the post-test remains map using the distance and angle from the original test item position. Figures C-1 and C-2 represent a sample post-test tabulation chart and post-test remains map respectively.

Post-Test Remains Tabulation Chart				
Test Type _____		Test Item # _____		Test Date _____
Fragment Number	Distance From Item	Weight	Angle	Description

Figure C-1. Post-Test Remains Tabulation Chart.

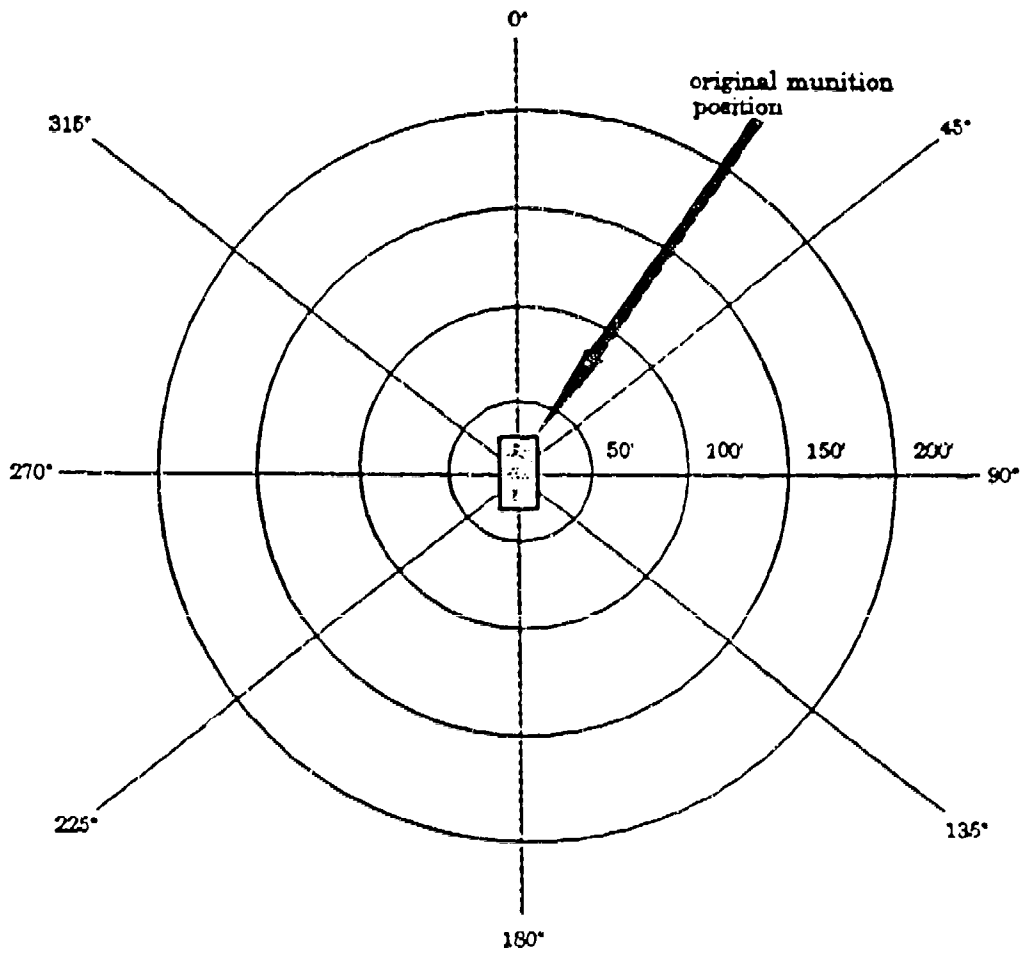

Figure C-2. Post-Test Remains Map.

APPENDIX D

REQUIRED REFERENCES

1. MIL-STD-2105A, Hazard Assessment Tests for Non-nuclear Munitions, 8 March 1991.
2. U.S. Army Supplement to MIL-STD-2105A (Navy), August 1992.
3. FR/GE/UK/US ITOP 4-2-805, Projectile Velocity and Time of Flight Measurements, 29 November 1991.
4. US TOP 1-2-504, Physical Characteristics, 31 October 1972.
5. US TOP 3-2-807, Non-destructive Testing of Materials, 5 December 1985.
6. MIL-STD-453, Inspection, Radiographic, 9 September 1988.
7. GE/US ITOP 4-2-820, Humidity Tests of Ammunition, 31 January 1984.
8. FR/GE/UK/US ITOP 1-2-601, Laboratory Vibration Schedules, 19 October 1992.
9. US TOP 5-2-507, Vibration Test, 10 April 1967.
10. GE/US ITOP 4-2-601, Drop Tower Tests for Munitions, 10 December 1984, CH1, 29 July 1986, CH2, 22 September 1987.
11. MIL-STD-331B, Fuze and Fuze Components, Environmental and Performance Tests For, 1 December 1989.
12. GE/US ITOP 5-2-619, Safety Testing of Missile Rocket, and Guided Projectile Employing Manned Launch Stations, 15 January 1986.

REFERENCES FOR INFORMATION ONLY

- a. 1991 JANNAF Propulsion Systems Hazards Subcommittee Meeting, Chemical Propulsion Information Agency, Publication 562, Johns Hopkins University, Columbia, MD, March 1991.
- b. Pakulak, Jack M., Jr., and Coraggio, Harpoon Insensitive Munitions Program Warhead Fast Cook-off and Slow Cook-off Study, NWC TP 6907, Naval Weapons Center, China Lake, CA, July 1988.
- c. Milton, R.W. and Thorn, L.B., Propellant Reactions and Damage Caused by Multiple Bullet Impact, 1991 JANNAF Propulsion Systems Hazards Subcommittee Meeting, Albuquerque, NM.