

Naval Research Laboratory

Stennis Space Center, MS 39529-5004



R.L.



AD-A269 015

NRL/FR/7183--92-9401



A Range-Dependent Transmission Loss Database Application: Countermeasures Assessment Simulation at NRaD

ROBERT E. DELGADO
BRUCE W. NORTHRIDGE

*Acoustic Simulations and Tactics Branch
Center for Environmental Acoustics*

L. SIMONE LADNER

*Planning Systems, Inc.
Slidell, LA*

S DTIC
ELECTE
SEP 07 1993
A **D**

July 1993

•Original contains color
plates: All DTIC reproduct-
ions will be in black and
white•

93-20546



Approved for public release; distribution unlimited.

93 0 02 021

REPORT DOCUMENTATION PAGE

Form Approved
OBM No. 0704-0188

Public reporting burden for this collection of information is estimated to average 1 hour per response, including the time for reviewing instructions, searching existing data sources, gathering and maintaining the data needed, and completing and reviewing the collection of information. Send comments regarding this burden or any other aspect of this collection of information, including suggestions for reducing this burden, to Washington Headquarters Services, Directorate for Information Operations and Reports, 1215 Jefferson Davis Highway, Suite 1204, Arlington, VA 22202-4302, and to the Office of Management and Budget, Paperwork Reduction Project (0704-0188), Washington, DC 20503.

1. AGENCY USE ONLY (Leave blank)	2. REPORT DATE July 1993	3. REPORT TYPE AND DATES COVERED Final
---	------------------------------------	--

4. TITLE AND SUBTITLE A Range-Dependent Transmission Loss Database Application: Countermeasures Assessment Simulation at NRaD	5. FUNDING NUMBERS <i>Job Order No.</i> 5715123B3 <i>Program Element No.</i> 0604270N <i>Project No.</i> <i>Task No.</i> <i>Accession No.</i> DN258092
--	--

6. AUTHOR(S) Robert E. Delgado, Bruce W. Northridge, and L. Simone Ladner*	
--	--

7. PERFORMING ORGANIZATION NAME(S) AND ADDRESS(ES) Naval Research Laboratory Center for Environmental Acoustics Stennis Space Center, MS 39529-5004	8. PERFORMING ORGANIZATION REPORT NUMBER NRL/FR/7183--92-9401
---	---

9. SPONSORING/MONITORING AGENCY NAME(S) AND ADDRESS(ES) Naval Command, Control and Ocean Surveillance Center R. L. Brandenburg, Code 773 San Diego, CA 92152-5000	10. SPONSORING/MONITORING AGENCY REPORT NUMBER
---	---

11. SUPPLEMENTARY NOTES *Planning Systems, Inc. Slidell, LA
--

12a. DISTRIBUTION/AVAILABILITY STATEMENT Approved for public release; distribution unlimited.	12b. DISTRIBUTION CODE
---	-------------------------------

13. ABSTRACT (Maximum 200 words) This report documents the effort to build a range-dependent transmission loss database, which would be used to support countermeasures assessment simulation at the Naval Command, Control and Ocean Surveillance Center, San Diego, CA. This "new" methodology supplants previous approaches based on the use of range-independent acoustic models (i.e., those that assume a single-profile, flat-bottom environmental input). The secondary purpose of this report is to introduce this capability to the wider community of simulation modelers. The presumption has been that, for the ASW engagement, it is beneficial to precompute as many of the terms in the sonar equation as possible. It follows that a database of modeled values of transmission loss (TL), a critical term in the sonar equation, would find widespread application in the ASW engagement segments of these analysis/training tools. The goal for this project was to produce a TL database by running the complex physics models, and then properly cataloging and storing the output for immediate retrieval and use. This procedure would then allow a modeled engagement to proceed in a timely manner through effective use of these "look-up tables." Although conventional thinking might have said that it is not feasible to model propagation loss for every 10° look direction for many combinations of source depth/receiver depth/frequency for scenarios in all of the world's oceans, this project has demonstrated that such a massive computational effort can be done, and is being done, given plenty of forethought, good science, and an abundance of automation. At the current rate of production, the resolution of the TL database averages one set of range-dependent TL model runs (i.e., one "node") every 1.5° x 1.5° square.
--

14. SUBJECT TERMS ocean environments, performance prediction, antisubmarine warfare	15. NUMBER OF PAGES 41
	16. PRICE CODE

17. SECURITY CLASSIFICATION OF REPORT Unclassified	18. SECURITY CLASSIFICATION OF THIS PAGE Unclassified	19. SECURITY CLASSIFICATION OF ABSTRACT Unclassified	20. LIMITATION OF ABSTRACT Same as report
--	---	--	---

CONTENTS

1.0 OVERVIEW	1
2.0 BACKGROUND	2
2.1 Early Beginnings—A Related Project	2
2.2 Countermeasures Assessment System (CMAS)	3
2.3 A Range-Independent TL Database for CMAS	3
2.4 The First Range-Dependent TL Database for CMAS	3
3.0 DISCUSSION	5
3.1 Province Methodologies	5
3.2 The Topography Analogy	5
3.3 The Essence of a Range-Dependent TL Database	7
4.0 DATABASE DESIGN	8
4.1 Definition	8
4.2 Contents of the CMAS TL Database	9
4.3 Using Multiple Radials	11
4.4 Mapping and Charting Support	12
4.5 Node Nomenclature	12
5.0 HARDWARE/SOFTWARE EFFICIENCIES	20
6.0 PROCEDURES	20
6.1 Planning Charts	20
6.2 Extracting Environment Databases	26
6.3 Batch/Software Jobstream Processing	26
6.4 Quality Analysis/Control	28
7.0 SOFTWARE OVERVIEW	30
8.0 RETRIEVAL SOFTWARE	33
8.1 Node Locator (FINDER) Software	33
9.0 ACKNOWLEDGMENTS	33
10.0 REFERENCES	34
APPENDIX — Description of the Application of Reciprocity	35

A RANGE-DEPENDENT TRANSMISSION LOSS DATABASE APPLICATION:

Countermeasures Assessment Simulation at NRaD

1.0 OVERVIEW

Simulation models are widely used throughout the U.S. Navy. Modeled Antisubmarine Warfare (ASW) engagements often involve multiple targets and receivers with dynamically changing geometries. It follows that the speed at which computations can be performed is an important aspect and a desired feature of any simulation scenario. A realistic goal is 1:1 real time. This goal suggests that, for the ASW engagement, it is beneficial to precompute as many of the terms in the sonar equation as possible. It follows that a database of modeled values of transmission loss (TL), a critical term in the sonar equation (and one which is difficult to compute within the timeframe desired) would find widespread application in ASW simulations.

Our goal for this project was to produce a TL database by running the complex physics models, and then properly cataloging and storing the output for immediate retrieval and use. This would then allow a modeled engagement to proceed in a timely manner through effective use of these "look-up tables."

Originally we were tasked to provide TL tables in ASCII form, formatted in a table for delivery on a 9-track tape in a format compatible with the DEC* VAX computer. The Naval Research Laboratory (NRL) VAX computer was used extensively for generating the initial set of TL tables for the Naval Command, Control and Ocean Surveillance Center (NRaD). Our early approach was based on the use of range-independent acoustic models (i.e., those that assume a single-profile, flat-bottom environmental input).

Subsequently, NRL oceanographers presented arguments concerning the increased fidelity inherent in using range-dependent acoustic models. In addition, NRaD's requirement for increased geographic coverage (eventually, global) was identified. The revised tasking pointed to rising computer and storage costs on the VAX mainframe. This, in turn, suggested that software be developed to run on desktop personal computers (PC). Computer storage problems were overcome with the purchase of relatively inexpensive mass storage devices for PCs. Use of the VAX mainframe was limited to the following:

(1) Input—environmental database extractions were made on the VAX; subsets of the global databases on the VAX were transported via Ethernet onto Bernoulli cartridges and staged for providing inputs to the acoustic model on the PC.

(2) Output—output files were passed to the VAX to be formatted for delivery.

*Digital Equipment Corporation

DTIC QUALITY INSPECTED 1

Accession For		
NTIS	CRA&I	<input checked="" type="checkbox"/>
DTIC	TAB	<input type="checkbox"/>
U	unannounced	<input type="checkbox"/>
Justification		
By		
Distribution/		
Availability Codes		
Dist	Avail. and/or Special	
A-1		

Efforts were made to stay abreast of new PC hardware developments:

- (1) Memory boards and math coprocessors for effective use of RAM were upgraded, and increased computing power was increased.
- (2) Ethernet was installed for communication with the mainframe; and
- (3) Optical storage technology.

Several specialized software developments were undertaken to support this project. Software used to conduct quality control on the output using screen colorgraphic displays was especially innovative. Also, a batch file scheme developed in-house significantly automated the process of running tens of thousands of model runs. Retrieval software was developed to run on both the VAX mainframe (for NRaD's use) and the desktop PC.

A simplified description of the process starts with the overall planning of the project and layout of the acoustic provinces. We perform environmental database extractions using INGRES software on the VAX mainframe computer. The files are transferred to the PC utilizing EATS software modules. Then the acoustic model processing used the range-dependent Navy-standard model ASTRAL (ASEPS* transmission loss) under control of the in-house developed batch file scheme. The final product is then properly cataloged and archived on the PC and transferred to the VAX for delivery.

Although conventional thinking might have said that it is not feasible to model propagation loss for every 10° look direction for many combinations of source depth/receiver depth/frequency for scenarios in all of the world's oceans, this project has demonstrated that such a massive computational effort can be done, and is being done, given plenty of forethought, good science, and an abundance of automation. At the current rate of production, the resolution of the TL database averages one set of range-dependent TL model runs (i.e., one "node") every 1.5° × 1.5° square.

2.0 BACKGROUND

The Naval Command, Control and Ocean Surveillance Center (NRaD), San Diego, CA, has been substantially involved in the development and use of the wargaming and simulation models that are widely used throughout the Navy. The database documented in this report is the result of the environmental acoustic (EVA) support provided by NRL for the latest in NRaD's simulation modeling efforts.

2.1 Early Beginnings—A Related Project

NRaD modelers were developing the Warfare Environment Simulator (WES) in 1981–82 when they turned to the Fleet Numerical Oceanography Center (FNOC) in Monterey, CA, for EVA support. The FNOC special projects team generated a database comprised of thousands of the Fast Asymptotic Coherent Transmission (FACT) model TL tables and hundreds of ship helicopter acoustic range prediction system (SHARPS) model active sonar range predictions. These modeled data were used in WES and subsequently became the "ocean model" for the Interim Battle Group Tactical Trainer (IBGTT) and the Research and Evaluation for Systems Analysis (RESA) model/tool. When last encountered (1989, at the Naval Postgraduate School), the RESA was still using this database of modeled ocean-acoustic parameters.

*Automated signal excess prediction system

2.2 Countermeasures Assessment System (CMAS)

NRaD recently developed this multiwarfare area simulation model. The purpose of CMAS is to support the Chief of Naval Operations' research requirements. For EVA support, NRaD turned to NRL.

2.3 A Range-Independent TL Database for CMAS

The first test for the NRL modelers was to update the data in the "ocean model," which was developed at FNOC for WES. [Note: Both NRL coauthors/modelers were previously stationed at FNOC.] These TL values were modeled using the new Navy-standard range-independent TL model (RAYMODE) and were provided for a limited number of ASW Prediction Areas (i.e., in the FNOC format). We used the NRL-developed VAX/VMS ASW Model Processing Network (VAMPNET) for our environmental databases and acoustic models (Rapp 1987) to automate the labor-intensive tasks of building acoustic model input decks. Since this processing allowed for only one frequency, source depth, and receiver depth geometry for each range-independent model execution, extensive use of VAMPNET was necessary to produce the numerous model executions efficiently.

2.4 The First Range-Dependent TL Database for CMAS

Once it was clear that the NRL modelers could mass-produce modeled acoustic products in a timely and cost-efficient manner (and in a compatible format), the task turned toward increasing the fidelity of the inputs to the CMAS simulation. The NRL modelers proposed that we reject the idea of limiting CMAS to an approach based on range-independent calculations. We proposed that we, as a community, "graduate" to the next level of sophistication: range-dependent modeling (Northridge 1990). The difference is an order-of-magnitude increase in the complexity of the EVA descriptions. Range-dependent descriptions of the ocean environment involve multiple radials of great circle path sections (known as "tracks" in the VAMPNET system) vice the single environment (point) processing implied by range-independence. The important technical issue at this point in the process was **efficiency**. Could such a large database be built in a timely, reproducible, quality-controlled, cost-efficient manner?

For demonstration purposes, NRL developed a procedure in which a range-dependent section of the ocean could be represented by laterally homogeneous assumptions. That is to say, the range-varying oceanographic and bathymetric inputs were extracted in one direction (in this case, a south-north section; see Fig. 1a) and not allowed to vary laterally (west-to-east). The areas represented covered 100 nmi \times 100 nmi. Eleven nodal positions were selected (Fig. 1b). The environmental description as it was extracted had the correct start-point and end-point for the first node only. The data were "rearranged" appropriately for the model runs at the other nodes. Figure 1c illustrates this sampling for the middle node. At each node, range-dependent model runs were made for a number of radials (Fig. 1d). Radial TL information from a (source) node was converted from spherical to rectangular coordinates to build a TL grid table with a TL value at each x, y point on a grid having 1-nmi resolution (i.e., these were 101 \times 101 matrices). This was done for each of the 11 node locations. The grid tables were then consolidated into a single file called a database. One of these databases existed for each source depth/receiver depth/frequency combination and for each new environment (e.g., different seasons). Because of the lateral homogeneity, the TL field for the same position on the y-axis but for different positions along the x-axis are just translations of the TL grid calculated for that (first-column) node. Although this calculation was handled by the software (Soileau 1988) that extracted TL values from the TL database (as opposed

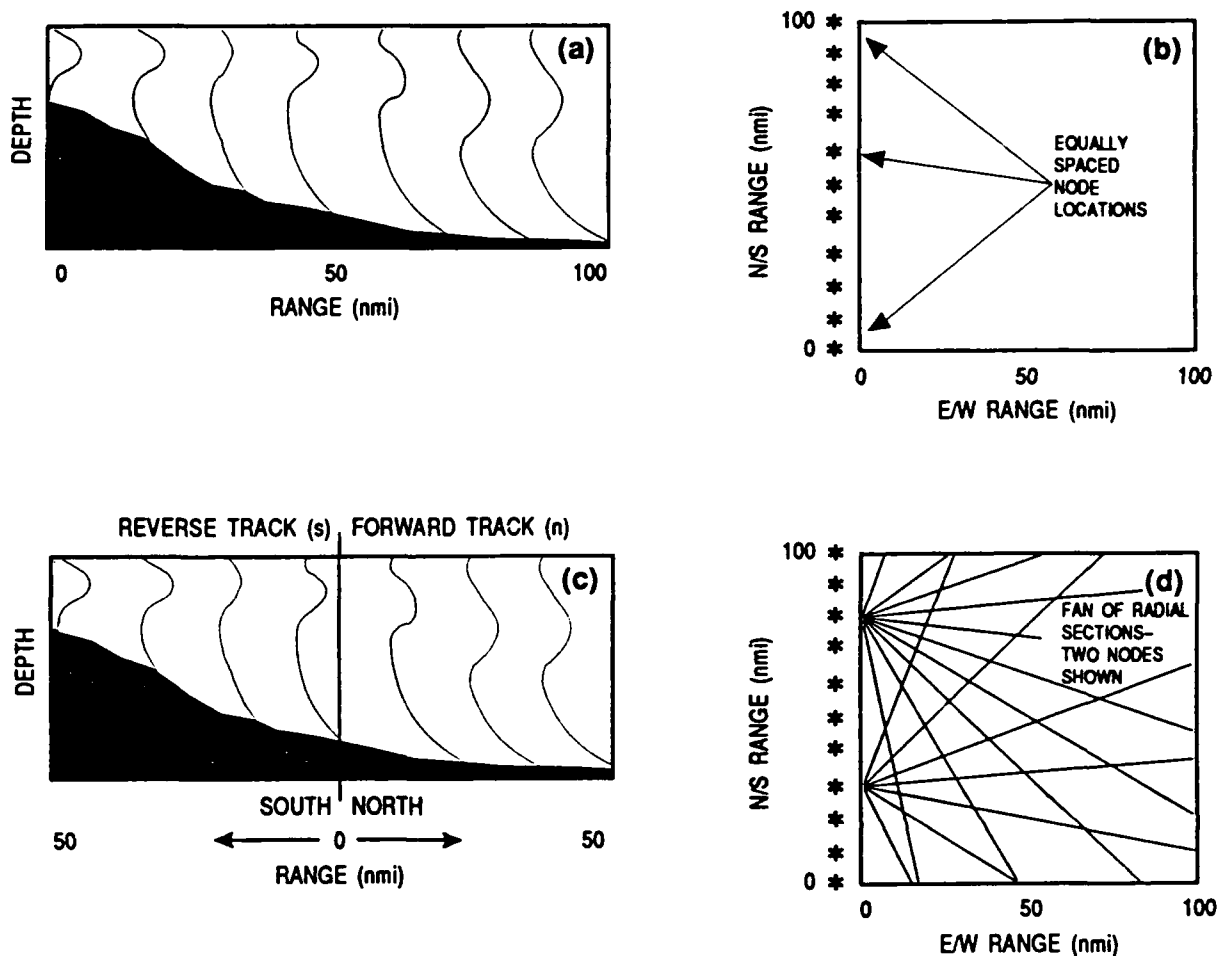

Fig. 1 — (a) Sound velocity environment input cross section, (b) ocean OPAREA layout, (c) bidirectional segmentation of sound velocity input cross section, and (d) nodal radial layout

to translating these matrices and storing many large files), the procedure gave the simulation modeler the “appearance” of a database where the TL from target to sensor was a function of range and bearing anywhere on the 101×101 playing field.

The acoustic model used was ASTRAL. It is capable of treating an environment where ocean depth, sound speed profile, and geoaoustic parameters vary as a function of range. In addition, ASTRAL is designed to process multiple frequencies, as many as six (6), with each model execution. NRL developed new methods of output storage featuring a newly designed binary format. Retrieval software was developed allowing the user to select and retrieve TL for a source located at any node point along the acoustic environment section. NRL also developed a user-friendly (menu-driven) method to pictorially display the numerous databases and environment sections. Program SHDPLT (Wooten et al. 1987) displays, in contour or in color format, a two-dimensional, 16-color DISPLA plot of an i -by- j matrix of data; this format allows NRL analysts to perform quality control easily at almost any step of the database’s build-and-access procedure.

This ultra-efficient initial approach was applied to a particular sonobuoy search study (Wilcox and Delgado 1988) and worked well. Eventually, however, the assumptions of lateral symmetry for

frontal regions and bathymetric slopes and seamount chains would require too many restrictions. The approach was determined to be too limited for NRaD's requirement for global ocean descriptions. We were forced to develop an alternative approach.

3.0 DISCUSSION

At its most basic level, the large-scale simulation requirement being tackled by this effort was to provide the TL input to the sonar equation for combinations of sensors and targets whose locations could be anywhere on the "field of play." Our TL data would be produced in radial form, representing the energy lost as it radiates out from the source. [A caveat to that assertion is cited in Sec. 4.2.] The center point is referred to as a "node." Let us suppose that the "field of play" is a grid whose resolution is 1 nmi \times 1 nmi. To make a new model calculation at the resolution equivalent to the scale at which we knew the source location (say, 1 nmi) would be a Herculean feat; it would also be overkill. Instead, we formulated the requirement in terms of a distribution of nodes in such a way that, for every gridpoint, there is a node nearby that is representative of its acoustic conditions. One could then consider the collection of gridpoints that were represented by the same node to be a "province."

3.1 Province Methodologies

There have been long-standing projects in the acoustics community to section the ocean into environmentally homogeneous areas, called provinces. Previous to range-dependent modeling, methodologies for provincing the ocean were based upon single environmental parameters. For example, the Naval Oceanographic Office (NAVOCEANO) ASW area charts (NWPCB series) were based upon areas of similar bottom conditions. Province Generalized Digital Environmental Model (GDEM) used the convergence zone distances from RAYMODE as a measure of when the sound velocity profile was significantly different. Since (as far as we know) this project is the first attempt to systematically use the output of range-dependent TL models in the computer environment of a large-scale simulation in a systematic way, we needed to invent a method that would represent any collection of contiguous gridpoints that have range and azimuthally varying environments that are acoustically similar—and call that collection of points a province. Another way of saying it is that the local area (province) must share **similar nonhomogeneous characteristics**.

A preliminary analysis of node distributions and provincing schemes was conducted by highlighting features and boundaries of the ocean acoustic environment. GDEM temperatures were contoured for a study area (surface, 100 m, 200 m, and 400 m); sonic layer depths were contoured; and bathymetric data from digital bathymetric database, ver. 5 (DBDB5), a Navy-standard database, were contoured. Since the spatial variability of the acoustic environment is a function of changes in the sound velocity profiles, the geoacoustics, and the bathymetry, correlation coefficients were generated and analyzed. The results determined bathymetry to be the primary factor in defining acoustic homogeneity within the region. However, there is a caveat: The oceanography could well have been more of an indicator of the spatial variability of the acoustic environment, except that the GDEM database is a smoothed climatological field that does not represent well the high gradient features (fronts and eddies) in the ocean.

3.2 The Topography Analogy

We proceeded to divide a given operations area into individual provinces with the following rationale. Imagine a sensor located on top of a mountain; we assume the far horizon can be seen

unobstructed in all directions. Everywhere on top of that mountain, the 360-degree picture is the same. If, for instance, one moved down the northern slope, then the view to the south would change rapidly. For a system that provides representations of that view, the requirement would be to provide more new pictures as one moves in that direction. Similar logic would apply to regions of slope. The view of the valley below would be similar for many miles if the same elevation walking along a ridge was maintained. If one went in an orthogonal direction (down the hill or up over the top of the ridge), then the view would change radically in just a short distance. In the traditional approach to acoustic province determination, areas that grouped together the average acoustic conditions were designed. Using this new approach, we outlined areas where the most rapid changes occur and define them. Essentially, a distinct view (a node) is needed for the top of a hill and separate distinct nodes for each different downhill direction. For each of these areas, a single location (usually the geometric center of the province) is selected to represent the environmental conditions of the entire province area.

Figure 2 is a computer-generated bathymetric chart of a subarea of the Norwegian Sea. The bathymetry is from DBDB5. Three different areas are outlined as provinces. Note the relatively flat area of the Voring Plateau. A representation of the acoustic characteristics for any source node located over this bathymetric feature might be expected to be valid over the entire plateau—in this case, bottom-interacting energy that fills the whole water column. But the analyst might assume that a characterization attached to this province should be to allow the acoustic energy to “escape” the confines of the plateau and to enter the sound channel that is available in the deeper water. Since the plateau is so large, we assume that acoustic paths across the breadth of this feature would incur enough bottom interaction to “kill” the energy before it could “escape.” So we outline the only northern portion and define it as province A. Along the northern slope of the Voring, we

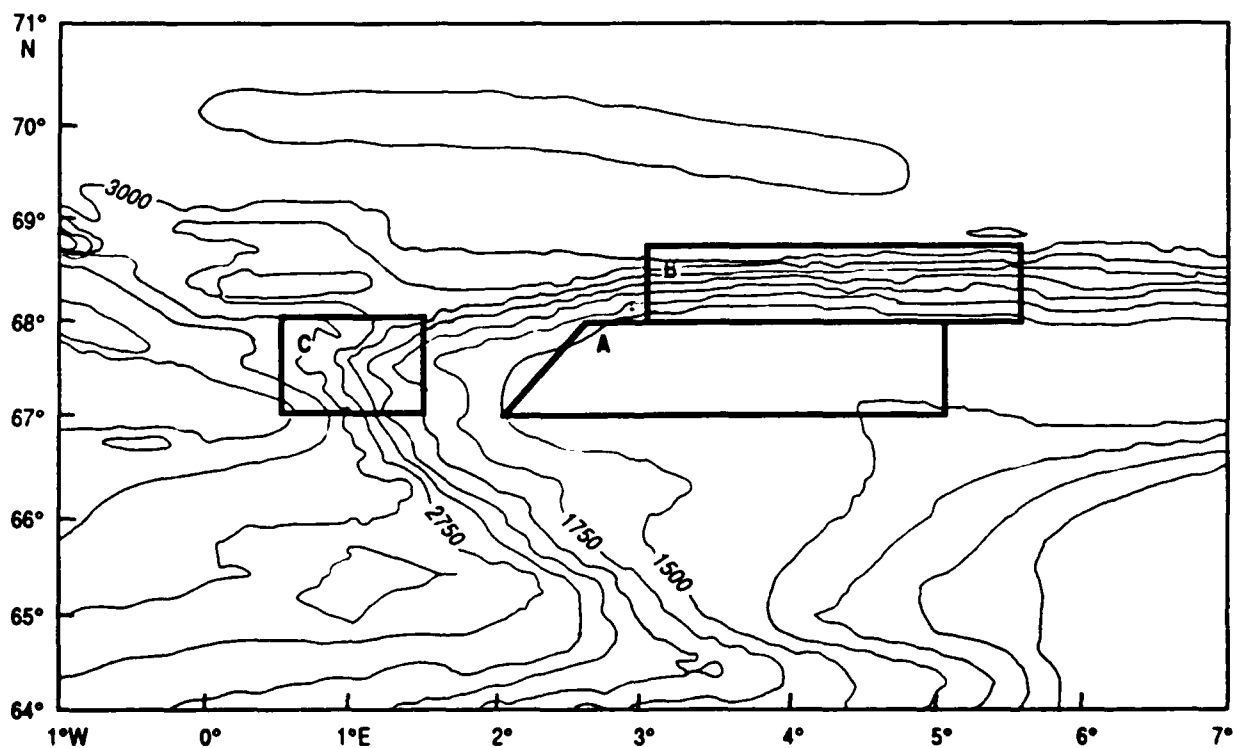

Fig. 2 — Norwegian Sea nodal plan

expect radically different acoustic environments in the uphill and the downhill directions. Since the gradient is quite uniform, we expect a fairly constant "view" for many miles in the east-west direction. We define province B as being much wider than it is tall, and we assume that the acoustic environment would not appreciably change from one grid cell to the next within the province area. Smaller area provinces are required as one approaches areas of rapid bathymetric change as seen along the western horn of the Voring slope (province C). We applied this same logic over entire ocean operation areas (OPAREA) to define provinces with similar characteristics. This procedure allows one node to represent the entire province area.

3.3 The Essence of a Range-Dependent TL Database

Figure 3 illustrates the results of modeling TL using the provincing scheme described above. Propagation loss is scaled according to the color bar shown. Province A, up on the plateau, displays

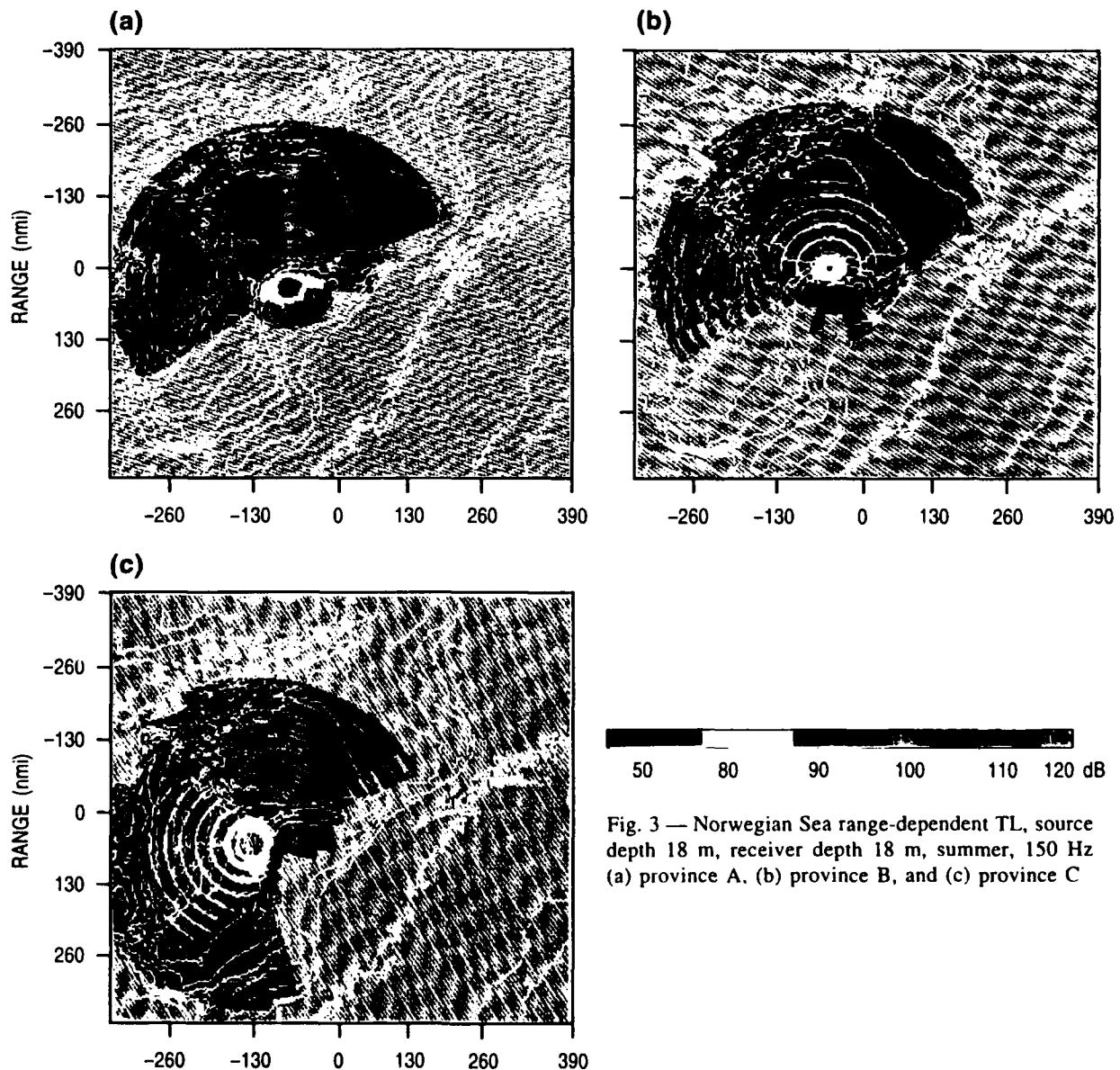

Fig. 3 — Norwegian Sea range-dependent TL, source depth 18 m, receiver depth 18 m, summer, 150 Hz (a) province A. (b) province B, and (c) province C

similar acoustic propagation (bottom limited) out in all directions to the edge of the plateau (Fig. 3a). A little energy does make it into the sound channels off the nearest edges (to the north and west). Province B, on the northern slope (Fig. 3b), shows that the acoustic energy does not propagate well back up the slope to the south, so there would be little chance of detecting a target situated over that slope using a sensor located on the Voring Plateau. Province C (Fig. 3c), on the western horn slope, shows similar upslope propagation patterns; this time the blockage caused by the plateau is to the east.

Two factors combine to make this database essentially new technology. (Although each factor has been available in the modeling community for a number of years, this is the first time [to our knowledge] they have been used together in a single product.) Building a database using the provincing scheme aids the user in understanding the spatial variability of the acoustic environment. Comparing Figs. 3b and 3c, the propagation differences between the northern and western slopes of the Voring Plateau can be seen. The second factor is the range-dependent modeling. A comparison of Figs. 3b and 4 shows the range-dependent vs. range-independent results for province B. Obviously, one would not have the same appreciation for the dynamics of the acoustic environment if one had to rely on the range-invariant results alone: yet the community has been relying on this simpler approach until now.

4.0 DATABASE DESIGN

4.1 Definition

The word database is frequently used to refer to a file or a group of files that may or may not be well organized. Strictly speaking, a database is a collection of logically related files. This use of the word logically refers not to the user's perception of the files or their use, but to the unique structure of the files that allows a computer program to access related data correctly from related files.

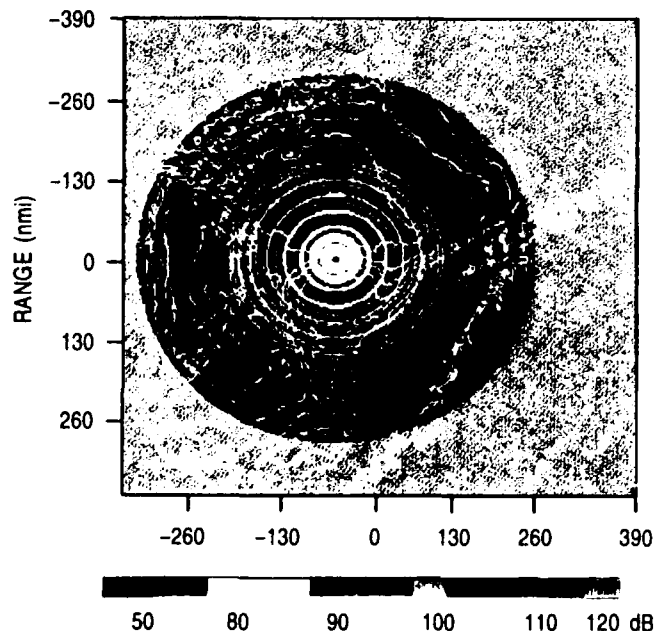

Fig. 4 — Norwegian Sea range-independent TL, source depth 18 m, receiver depth 18 m, summer, 150 Hz, province B

Within this collection of files called a database, each file contains various records. Each record in each file can be uniquely identified by the use of a "key." A key is a field whose value uniquely identifies each record. In simple scenarios, such as the environmental databases used as input to this process, records of data with the same key are logically related regardless of the file in which they are contained. For example, DBDB5 contains latitude, longitude, and a depth value. GDEM contains latitude, longitude, and a sound velocity profile. Thus, by using the latitude and longitude as the unique key, a computer program could extract a sound velocity profile with the appropriate depth.

Strictly speaking, the collection of TL files documented here is not a database. There is no key within the files that uniquely identifies the data. All the knowledge about the contents of these files is contained in the filename. This is why it is so important with this database to create and document a complete, correct, and consistent filename convention.

This report documents our methodology for putting modeled TL output in a format that will be used as a "look-up table" for such applications as wargames and simulations of naval operations. Specifically, our methods for storing the output, for retrieving the processed data, and for quality controlling the data were originally developed for use on the VAX computer. To reduce costs for this project, these methods were converted to software that operated on IBM-compatible PCs. The CMAS database was built entirely on the PC, and the output was transferred to the VAX using Ethernet and delivered via 9-track tapes (later, via optical disks).

4.2 Contents of the CMAS TL Database

The CMAS TL database is initially generated in ASCII tabular form that contained TL for each node and each season for three source/receiver geometries, eight frequencies, and 36 radials with an output resolution along a radial of 1-nmi increments for 300 nmi. The ASCII form of the database was then compressed into a binary direct access (BDA) format for ease of storage and rapid retrieval of information.

4.2.1 CMAS TL Database—Nodes

The CMAS TL database currently contains 1844 nodes in the North Atlantic and 2003 nodes in the North Pacific (Fig. 5).

4.2.2 CMAS TL Database—Seasons

The CMAS TL database currently contains data for summer and winter.

4.2.3 CMAS TL Database—Source/Receiver Geometries

Through discussions with the sponsor, it was decided that one shallow target (source) and one deep source would be modeled. Also, one shallow receiver and one deep receiver would be modeled. The discrete depths selected for model depth geometry inputs are as follows:

Shallow = 18 m (~60 ft)
Deep = 381 m (~1250 ft)

The CMAS modeler will, of course, have targets and sensors at more than just these two depths; however, that is an implementation issue for NRaD. A description of one of the methods discussed follows. For environments with substantial surface ducts, SHALLOW would represent

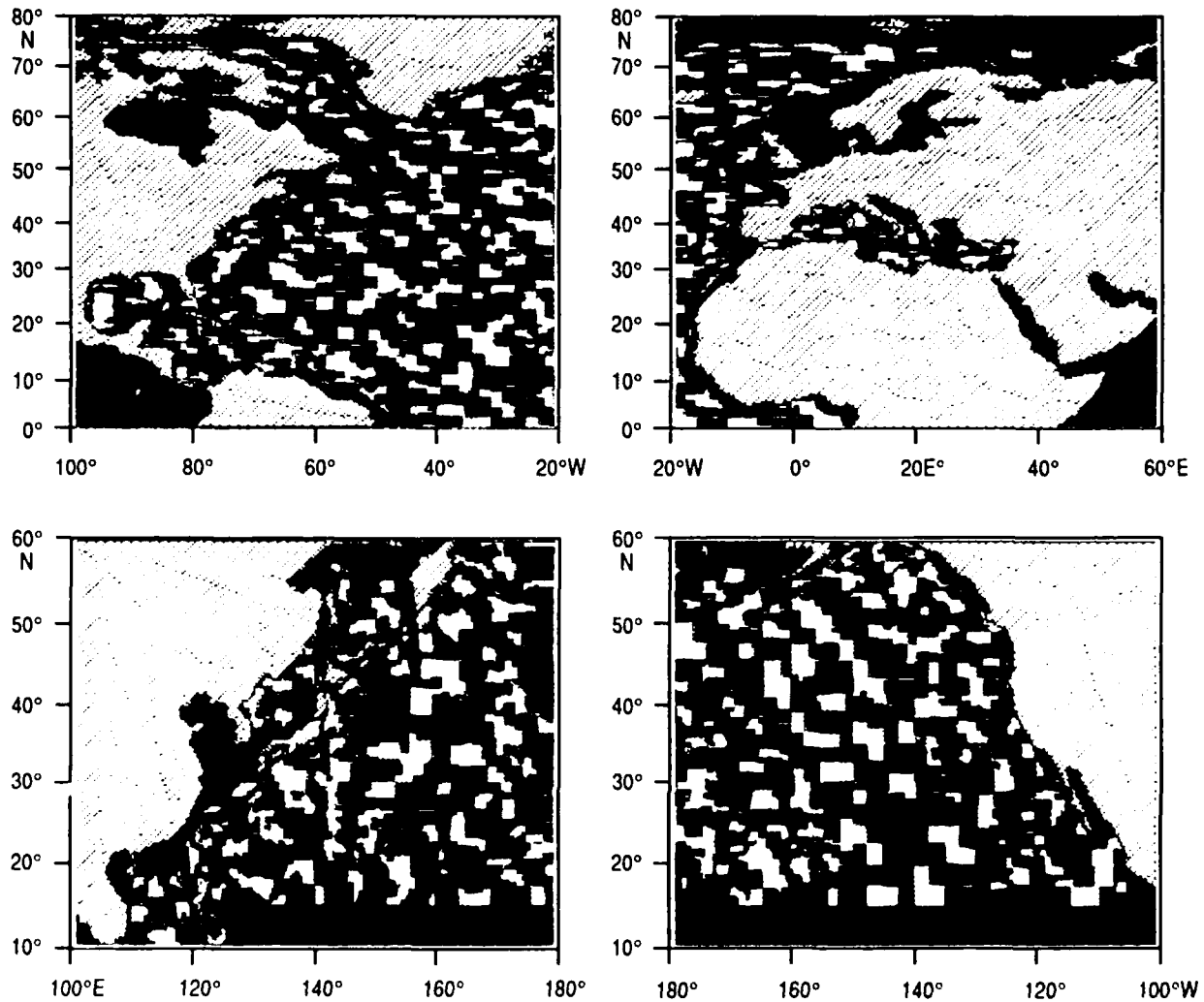

Fig. 5 --- North Atlantic Ocean and North Pacific Ocean OPIREA node locations

any source or receiver shallower than the sonic layer depth, and DEEP would be used for source or receiver deeper than the sonic layer depth. The Program SVPANA (Secs. 6 and 7) identifies the sonic layer depth in each province and is provided for this purpose.

For those provinces shallower than 381 m, the DEEP depth was adjusted shallower than the bottom depth to keep the sensor within the water column (~10 m above the DBDB5 depth).

Figure 6 identifies the four source-receiver geometries required by the CMAS simulation.

- (1) SHALLOW Source to SHALLOW Receiver (SS)
- (2) SHALLOW Source to DEEP Receiver (SD)
- (3) DEEP Source to DEEP Receiver (DD)
- (4) DEEP Source to SHALLOW Receiver (DS)

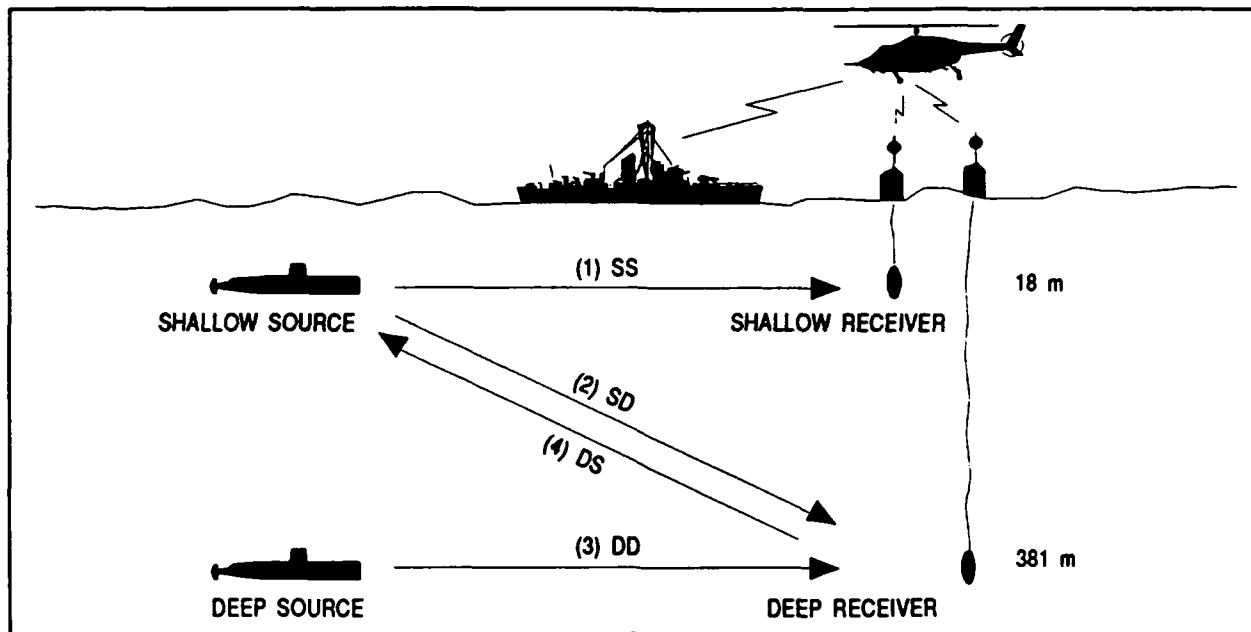

Fig. 6 — Model geometry plan

The careful reader may have noticed that the database was described previously as having only three source-receiver geometries, namely, (1)–(3). This description is true. The fourth case is implemented for CMAS simulations by invoking acoustic reciprocity (and using type (2) TL from the node corresponding to the location of the SHALLOW Receiver). An example is described in the appendix.

4.2.4 CMAS TL Database—Frequencies

The CMAS database currently contains TL for the following frequencies: 25, 50, 150, 315, 630, 900, 1250, and 1600 (Hz).

4.2.5 CMAS TL Database—Radials

The environmental data were extracted, and the ASTRAL model was run, for 36 radials at 10° intervals from 0 to 350° .

4.3 Using Multiple Radials

Range-dependent TL modeling is not new. Software to extract the required environmental inputs along a great circle path (also called a track, a radial, or a section) by reaching into the grid format (sound velocity profile, bathymetry, and geoacoustic) databases has also been available for a few years. The relatively new software is the NRL program that extracts multiple environmental sections at user-specified angle steps and ranges about a particular location. A single section (track) of range-dependent environmental parameters is combined with tracks from other radials—all extracted from a single location. This defines the environment in all directions from that central point and determines a circular area of coverage (STAR; the output TL plots have also been referred to as “wagon wheels”). Each STAR, although generated at a particular location within a province, defines the environment for the entire province.

Another NRaD implementation issue involves the interpolation necessary to arrive at the "correct" TL for a target lying at a particular bearing and range from a sensor. Obviously, the accuracy of that process is a function of the number of radials (36) and the great circle distance range steps (1 nmi) selected at the time the database is built.

4.4 Mapping and Charting Support

As discussed in Sec. 3, the provincing scheme required that we identify areas of environmental differences, especially high-gradient bathymetric differences. Large-scale bathymetry charts were needed. The chart for the original Norwegian Sea OPAREA study was developed by splicing pieces of four NAVOCEANO charts. However, the extent of the final CMAS database (global coverage) required that a more efficient method be found for building these planning charts. NRL workstation experts developed a method of generating large-scale charts using the same bathymetry database, DBDB5, as was used for the ASTRAL TL computations. These products were desktop-sized (2 ft × 3 ft or larger) charts usually covering 15° of latitude and 20° of longitude. Printed on these charts was a map overlay grid with a resolution of 1/4° latitude × 1/2° longitude. This grid was used to define the province boundaries at that resolution. (Note: At the latitude of the first prototype OPAREA that we tackled—the Norwegian Sea at 60°N this grid resolution is 15 nmi × 15 nmi.) Contiguous cells of the grid that were deemed acoustically similar defined the individual nodal province areas.

4.5 Node Nomenclature

A naming convention was required to define geographic points and areas used in generating this database (and for possible future use in other environmental studies). We needed the nomenclature convention to fit within the constraints of DOS file character limitations. We also wanted it to provide a rational approach for embedding geographic information so that the database contents would be "tagged" to any one of a large number of locations. Also, the plan was to build a node location program (FINDER) that had to correlate a particular location (latitude/longitude) to a particular filename (where that file contained the data for the appropriate individual node). A naming convention was designed utilizing the eight characters of a DOS filename (the three characters of the DOS file extension indicate file type).

The CMAS database nomenclature convention is described below. Using this convention, the FINDER program was built (Sec. 8). The nomenclature convention has four parts:

- A procedure to specify database type (DETERMINISTIC or RANDOM).
- An external indexing scheme to locate the rectangular area on a global coordinate system.
- An internal scheme to define subareas or point locations within the rectangular area.
- A method to identify the season.

4.5.1 Database Type

The first character (C1) defines the database type. There are multiple implementations possible for each of the two basic database methods: deterministic or random. A deterministic scheme implies that the data are evenly distributed spatially and that they enjoy a 1:1 correlation with the grid cells in the database (which have a user-defined resolution). We envisioned that the deterministic scheme would be utilized to build range-independent TL databases that can be adjusted in resolution by defining the appropriate grid size. (Note: A range-independent TL database was built on a coarse

resolution [5° grid] featuring this deterministic database scheme for the purpose of demonstrating this method.) A random scheme implies that the data (i.e., the province areas) are nonuniform in size and shape.

The CMAS TL database being documented here is a randomly spaced vice evenly spaced deterministic database. Our random designed database is divided into large rectangular-shaped ocean OPAREAs (10° of latitude × 20° of longitude), each having numerous subareas. These subareas contain the provinces that are irregular in size and shape (random). These provinces may range in size from the smallest grid-cell resolution (the individual cell size is 1/4° latitude and 1/2° longitude) up to the full size of the subarea (10° of latitude × 20° of longitude). In fact, of the OPAREAs built and delivered thus far, the smallest province is 1 cell; the largest is 121 cells; the average size is 18 cells. On average, then, the CMAS TL database has a resolution of 1.5° × 1.5°.

The following table summarizes the two database types and resolutions with which we have experimented. Additional characters can be assigned as necessary to define a scheme for a particular application.

C1	Rectangular Area (Lat × Lon)	Type	Coverage
T	10° × 20° (Fig. 7)	Random	Global
D	5° × 5° (Fig. 8)	Deterministic	Global

4.5.2 Ocean OPAREA

The next two characters (C2 and C3) are used to define the large ocean OPAREAs. We designed the database OPAREAs to closely follow the Standard Navy Ocean Area and Region Index Limits published by the Defense Mapping Agency Hydrographic Center (DMAHC; Fig. 7a). A global system would include databases of the seven major ocean areas:

1. NP North Pacific Ocean (Fig. 7b)
2. NA North Atlantic Ocean (Fig. 7c)
3. IO Indian Ocean (Fig. 7d)
4. SP South Pacific Ocean (Fig. 7e)
5. SA South Atlantic Ocean (Fig. 7f)
6. AR Arctic Ocean (Fig. 7g)
7. AN Antarctic Ocean (Fig. 7h)

4.5.3 External Index for Subareas

The next characters (C4 and C5) are used to define the external index of the reference latitude and the reference longitude, respectively for the subarea rectangle.

Figure 7b is the North Pacific (NP OPAREA) chart showing the 10° latitude by 20° longitude, externally indexed subareas. This OPAREA was designed for seven individual latitude zones (0°N to 70°N in 10° increments) and nine individual longitude zones (100°E to 80°W in 20° increments)

externally indexed from 0°N and 100°E (every ocean OPAREA external index originates from the **southwestern** corner of the individual OPAREA). The numeric characters 1 through 7 define the latitude grid index zones. Each zone is listed in ascending order from the index in both northward and eastward directions. For this case (NP) at 0°N/100°E, the latitude grid index zones start from 0°N increasing northward in 10° blocks and are assigned the characters 1 through 7, respectively. The longitudinal grid index zones start from 100°E, increasing eastward in 20° blocks assigning the numeric characters 1 through 9, respectively.

Figure 7c shows the NA OPAREA grid-indexing scheme. The NA area is externally indexed at 0°N/100°W extending northward to 80°N in 10° blocks and eastward to 60°E in 20° blocks. This system overlaps the NP grid from 100°W to 80°W. The overlap was necessary because the Gulf of Mexico is positioned in the same longitude band as the easternmost part of the North Pacific Ocean. There are similar overlaps between other OPAREAs.

For OPAREAs originating in the Southern Hemisphere, the databases will be externally indexed the same as those in the Northern Hemisphere (all originate from the **southwestern** corner of the individual OPAREA). Each increments toward the North Pole in 10° block steps and toward the east in 20° block steps.

4.5.4 Location Within the Rectangle

Characters 6 and 7 (C6 and C7) are used to provide intra-rectangle (sub-subarea) relative location information. The scheme used for a particular project is chosen during the database design phase of the modeling project when the OPAREA directories are initially established. Two basic types of intra-rectangle indexing are addressed at this time:

- The uniform/serial indexing convention. Figure 8 is an example of a deterministic scheme that subdivides the NA OPAREA externally indexed grid (subarea-NA46) into a 1° by 2° grid. One nodal point, at most, can be assigned to each sub-subarea at the geometric center, which makes this scheme appropriate for equally spaced node locations. Boundaries are defined so the individual sub-subarea owns the southern and western walls.

- The random indexing convention allows for the maximum flexibility in assigning nodes (data points) within a subarea rectangle. This type of indexing permits the user to define the number of nodes (provinces) from as few as one to as many as 100 (labeled 00 to 99) random areas within the rectangle each of varying size. The CMAS database was designed utilizing the random indexing convention.

4.5.5 Season Indicator

Character eight (C8) is used to define the season of the file. The following alphabetical characters represent the seasons:

S Summer

F Fall

W Winter

P Spring

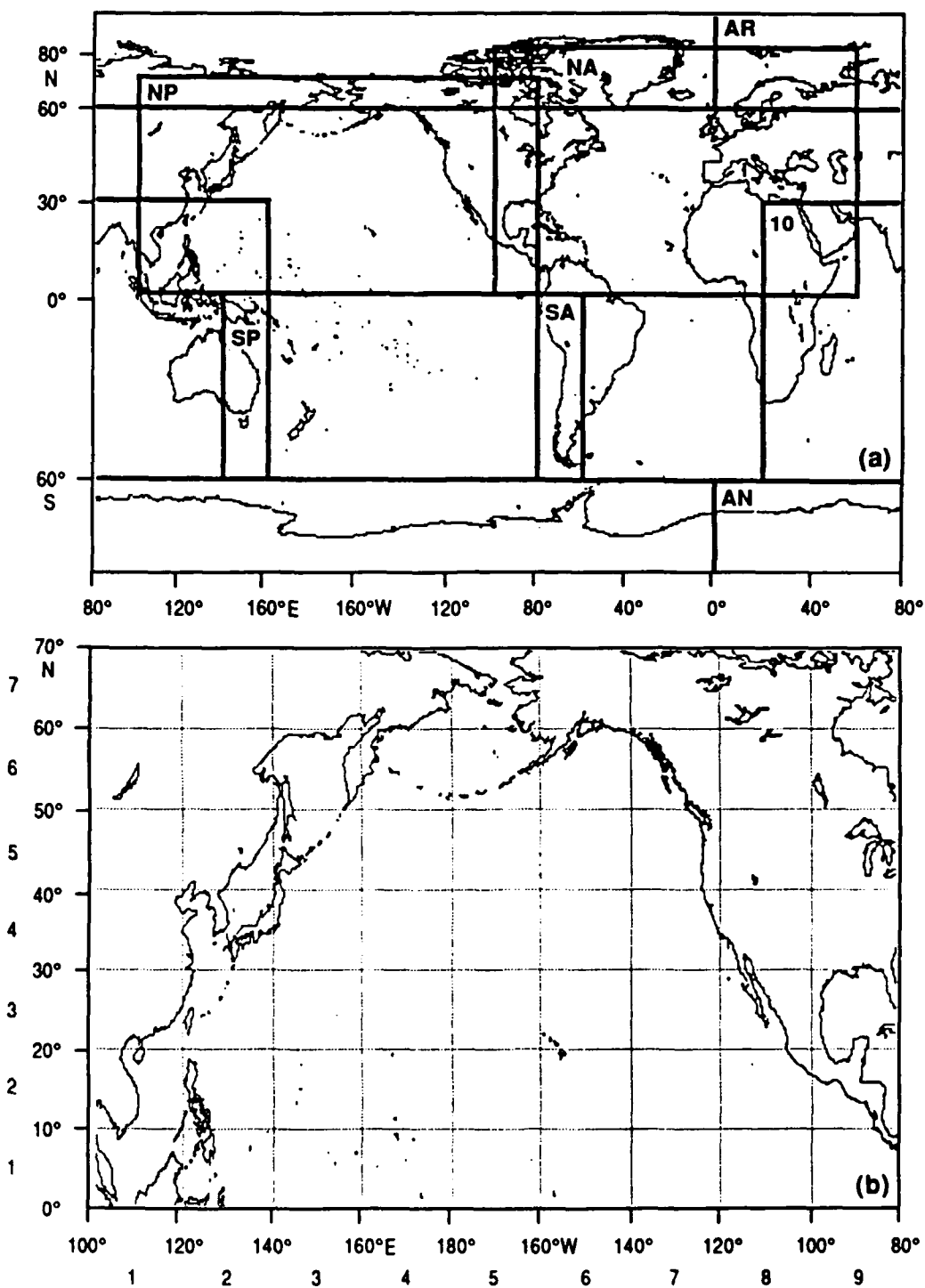

Fig. 7 — (a) Ocean OPAREAs plan and (b) North Pacific OPAREA

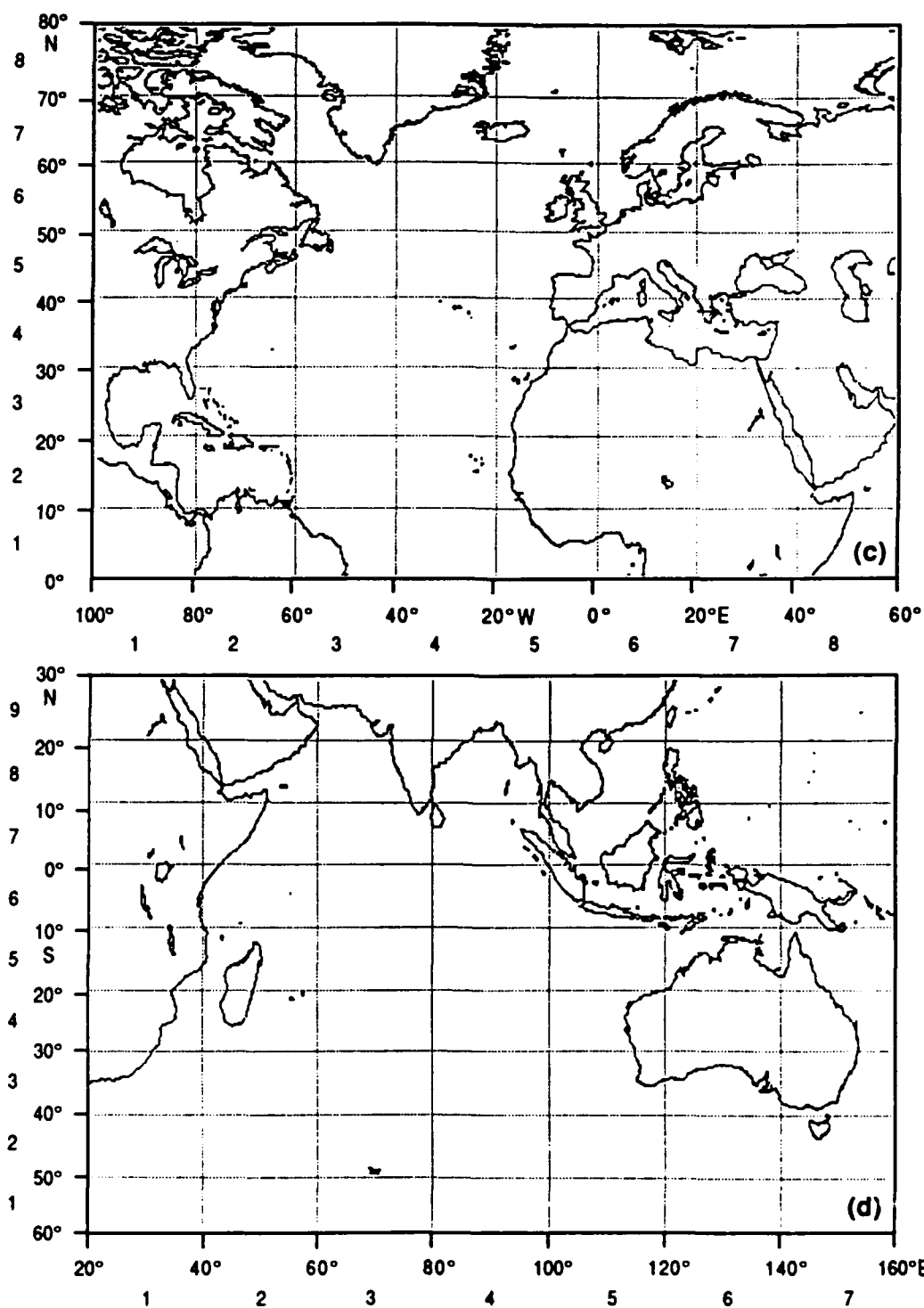

Fig. 7 — (c) North Atlantic OPAREA and (d) Indian Ocean OPAREA

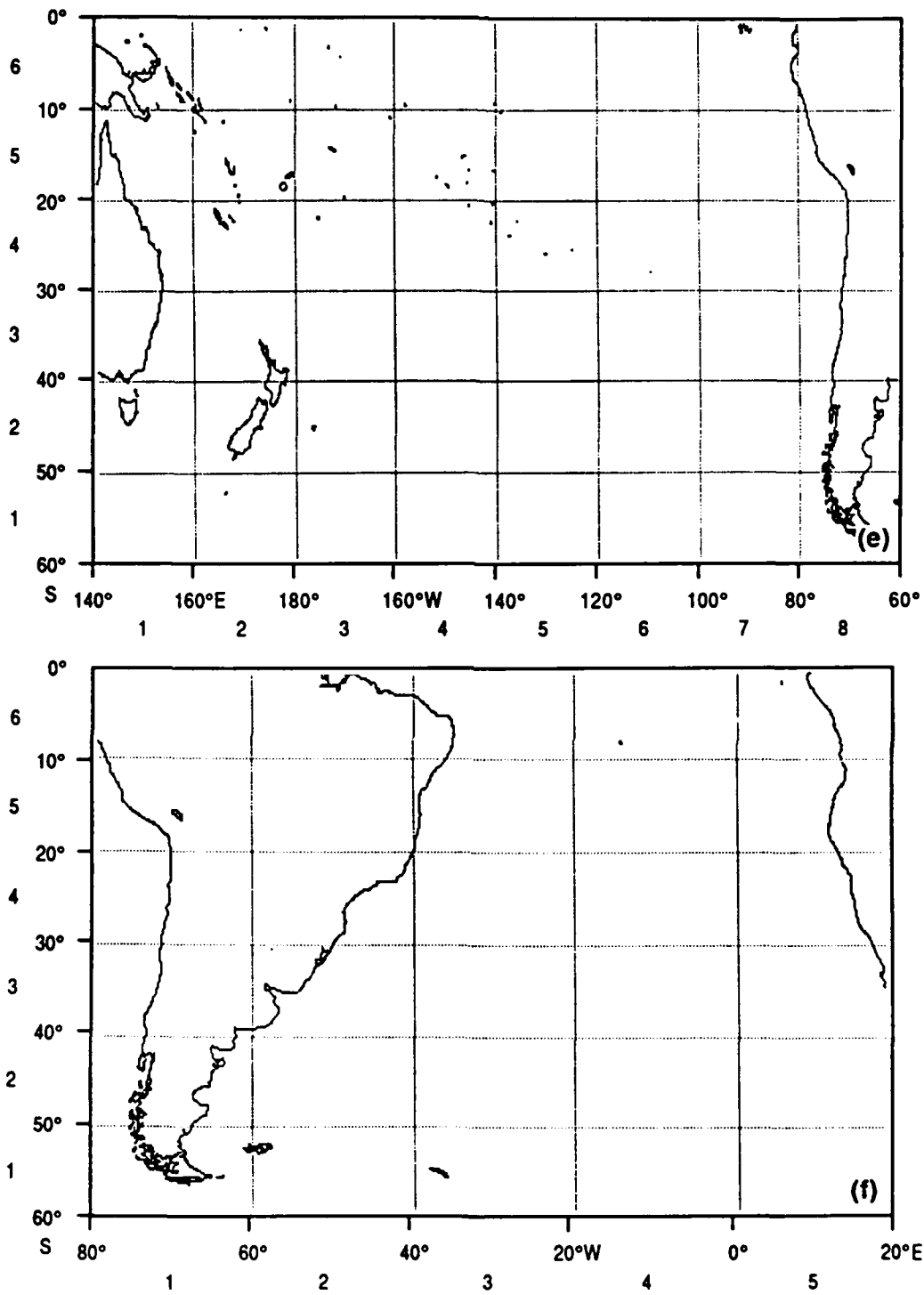

Fig. 7 — (e) South Pacific OPAREA and (f) South Atlantic OPAREA

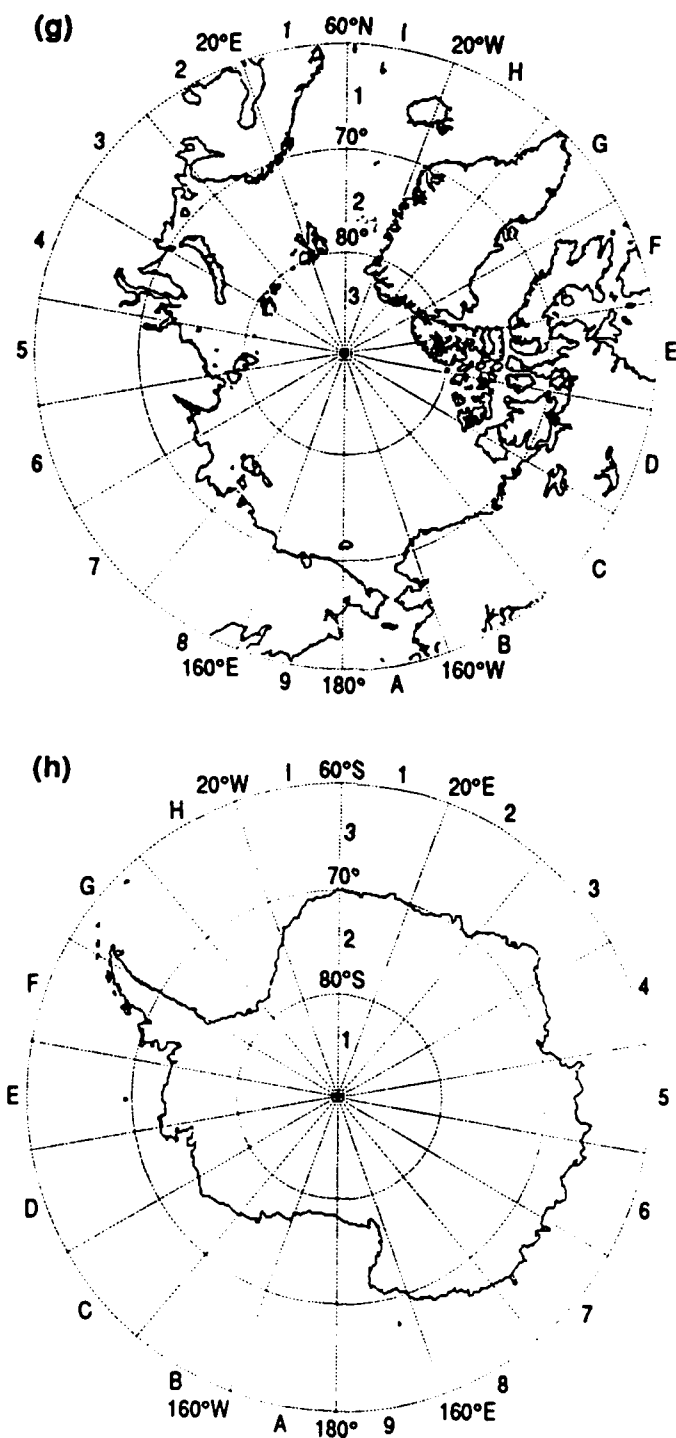

Fig. 7 — (g) Arctic OPAREA and (h) Antarctic OPAREA

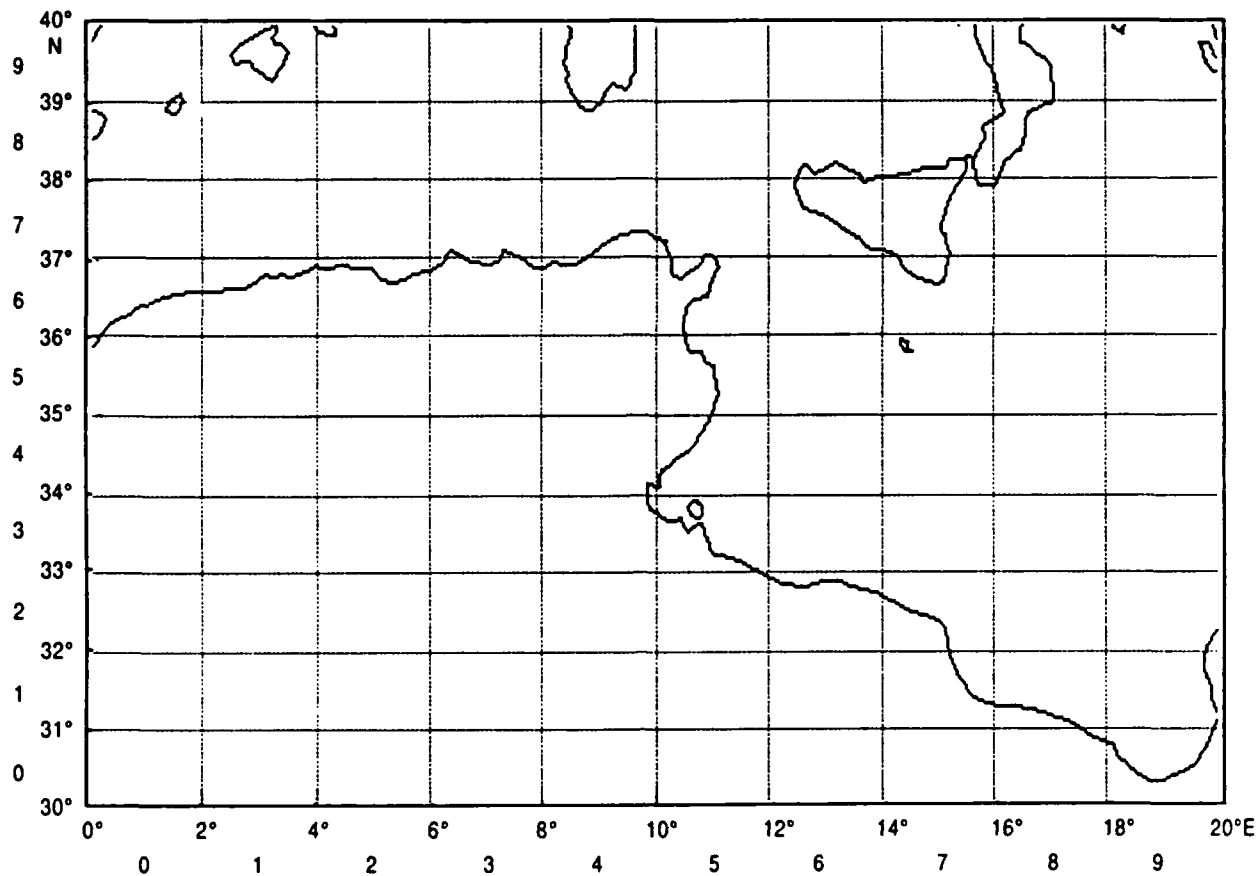

Fig. 8 — Mediterranean Sea

4.5.6 File Types

The file types are determined from the file extensions assigned. This project required four different types of files; a fifth was found to be very useful. They are listed below and explained in greater detail later:

- (1) *.DAT is an ASCII file containing the TL output.
- (2) *.BDA is a binary direct access file containing the TL in a compressed form for better storage and faster retrieval of information.
- (3) *.GEO is an ASCII file containing the model geometry information.
- (4) *.PIX is a saved picture element file (pixel) that can be redisplayed on the screen or plotted for quality analysis/control.
- (5) *.ARC is the archived file that contains all of the above.

A representative filename follows: TNA4657P.BDA. From the table in Sec. 4.5.1, we know that T denotes a random nomenclature scheme. NA defines the ocean OPAREA of the North Atlantic (Fig. 7c). The next two numbers, 4 and 6, define a subarea containing the island of Sicily in the Mediterranean Sea [remember—latitude is always first]. Using the random indexing convention, 57 indicates a node number (a province) within the subarea (Fig. 8). The province latitude

number 5 indicates in a relative sense that the node resides somewhere within the latitude band of 35°N to 36°N, and the longitude number 7 indicates that the node resides somewhere in the longitude band 14°E to 16°E. For example, the island of Malta resides within the area of the band intersections listed. A deterministic scheme would have fixed the location of the node to the center point 35.5°N/15°E and would have completely defined the cell. The random scheme indicates only a relative position within the subarea. Malta does not occupy the entire area and is actually surrounded by provinces that may either reside within the same band or extend to neighboring band area intersections. The Sicilian island land mass extends into five sub-subareas (67, 76, 77, 86, and 87). The file extension name indicates this file contains node TL data in Binary Direct Access format.

5.0 HARDWARE/SOFTWARE EFFICIENCIES

A primary concern for the new TL database procedure was that it be compatible with any future developments. NRL considers the issue of TL database construction to be one of increasing sophistication as hardware and software improvements are developed and become available. The basic technology was built around range-independent TL per ASW area. An intermediate technology was built around range-dependent TL with some limitations imposed (i.e., lateral homogeneity). The ultimate goal is to obtain range-dependent TL curves radially from every point on a fine-resolution grid over the entire OPAREA. The roadblocks to achieving this goal are manpower for model setup, CPU costs, execution time to run the models, manpower for model postprocessing, and the necessary hardware storage devices to house the output.

The cost for VAX mainframe CPU and storage for this project was prohibitive, so we investigated the feasibility of running on DOS-based PCs. New hardware developments in PC mass storage devices (such as the removable floppy cartridge and optical disk devices), speed-up boards, the greater speed of the 386 microprocessors, and the use of extended memory for random-access memory (RAM) disk working areas allowed us to build a TL database by using newly developed PC job control (batch file) procedures. Also, the newly acquired Ethernet technology allowed us to communicate rapidly with the mainframe computer as necessary for accessing the Navy-standard databases and for building output delivery files. Numerous PCs now process the TL database in large blocks. The VAX mainframe computer is still used to access the Navy-standard environments and to package the completed product for delivery. Each PC is programmed to run node after node automatically 24 hours a day (with minimal interruptions to collate input and output). This carefully designed procedure has allowed us to closely approach our goal for automating the range-dependent TL database building process.

6.0 PROCEDURES

6.1 Planning Charts

Planning charts were generated by contouring DBDB5 data with an Intergraph-workstation. Each externally indexed subarea chart of an ocean OPAREA contains bathymetric contours at 200 m intervals with an overlay grid of 1/4-degree latitude and 1/2-degree longitude resolution. The files were printed in standard Mercator chart format at NAVOCEANO. The sub-subarea provinces are determined manually in the manner discussed above (Fig. 9). Each province is fit to the overlay grid. Individual cells of the grid are directly mapped to the province they overlay. Figure 9 depicts the grid overlay over the province areas A, B, and C of Fig. 2, thereby defining the provinces

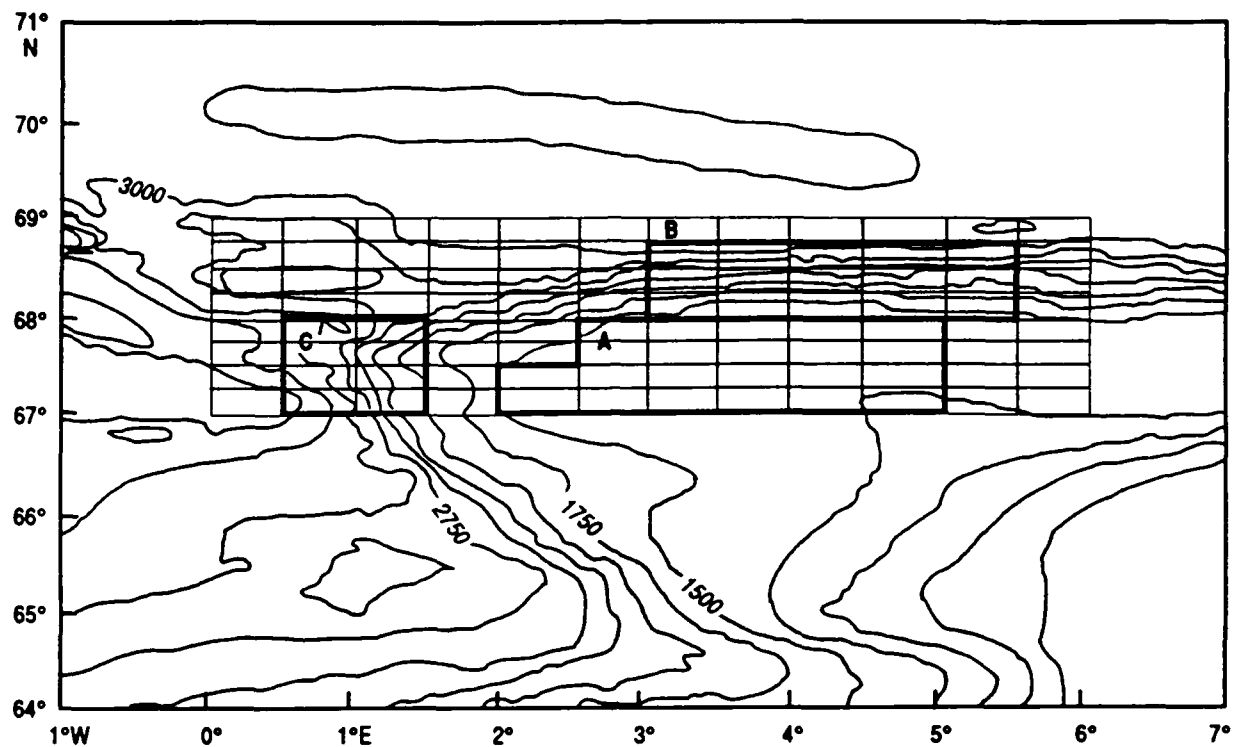

Fig. 9 — Norwegian Sea nodal cell resolution

showing the individual cell compositions. The thick boundary lines show the limits of the provinces. All cells located over land or over very shallow areas (<100 m) are assigned the value 0000. The first two characters (C4 and C5 of the node name) are the external indexing digits: The values 00 indicate land or shallow water in all ocean OPAREAs and are considered out-of-bounds for this database.

The random indexing scheme allows as many as 100 asymmetrically shaped provinces to be designed into a particular subarea. A single point is chosen (usually near the geometric center) to represent the entire province. Each province is then assigned a two-digit internal indexing number (C6 and C7 of the node name). Although we utilized the random indexing scheme, we assigned the node numbers in a manner that approximated a deterministic nomenclature scheme to indicate relative position within the subarea. The number 55 indicates that a node is located approximately in the center of the subarea; 00 indicates a relative position at or near the southwest corner; and 99 indicates a relative position near the northeast corner. The node position information (latitude/longitude) is then used to create the numerous input decks on the PC as described below. Concurrently, the province cells are manually digitized on a Macintosh computer using Microsoft Excel spreadsheet software. The digitized charts are transferred to the VAX and PCs to create the binary files that can be accessed by the finder software or plotted.

After the provinces are determined and the maps prepared, the Input Deck files are created (The database integration overview is depicted in Figs. 10a through 10d). The Input Deck files contain information about the nodes that make up each province (Fig. 10a, Process 2.0). Each file contains node numbers, latitude and longitude for the given node number, wave height, depth,

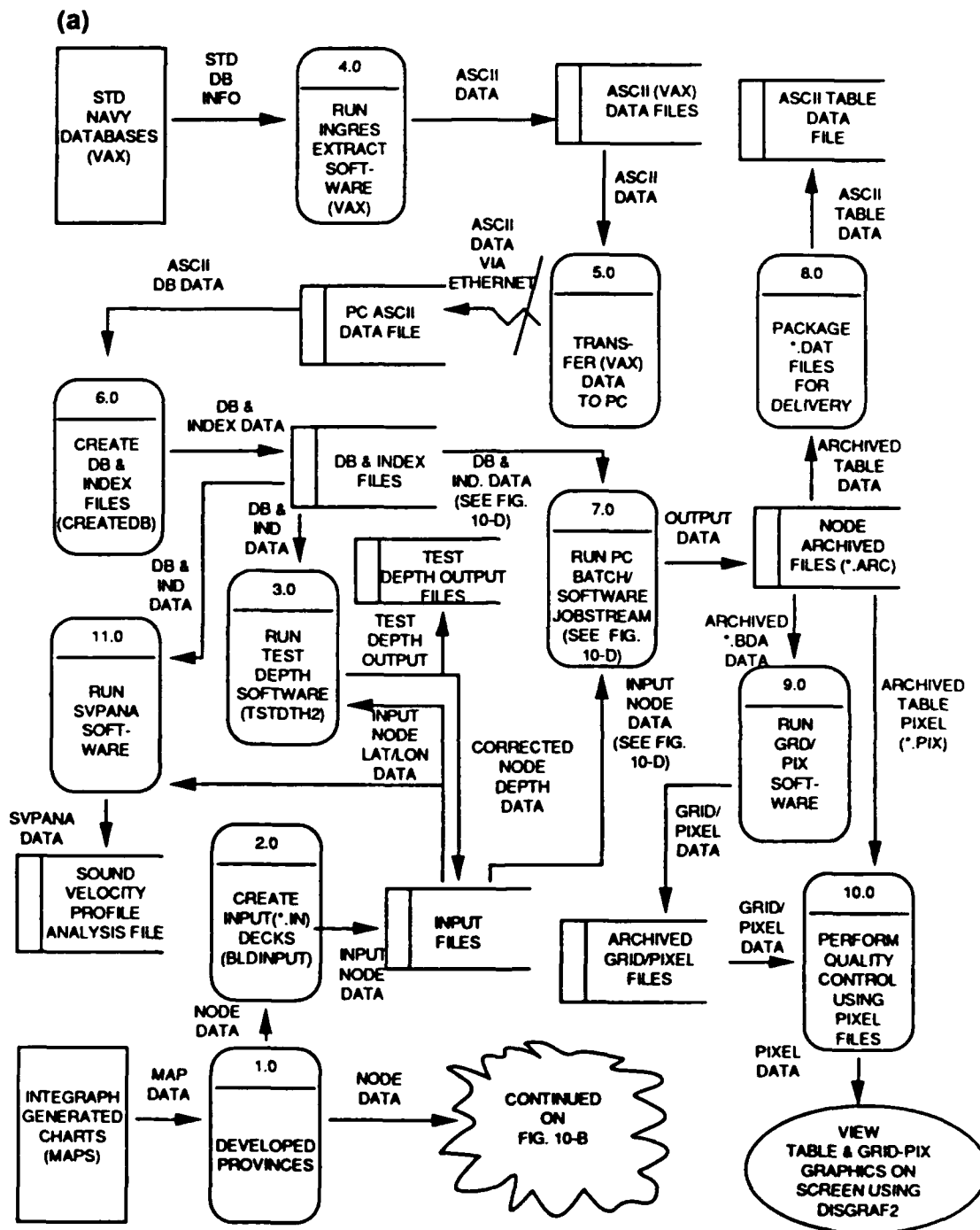

Fig. 10 — (a) TL database integration procedure overview (level 1)

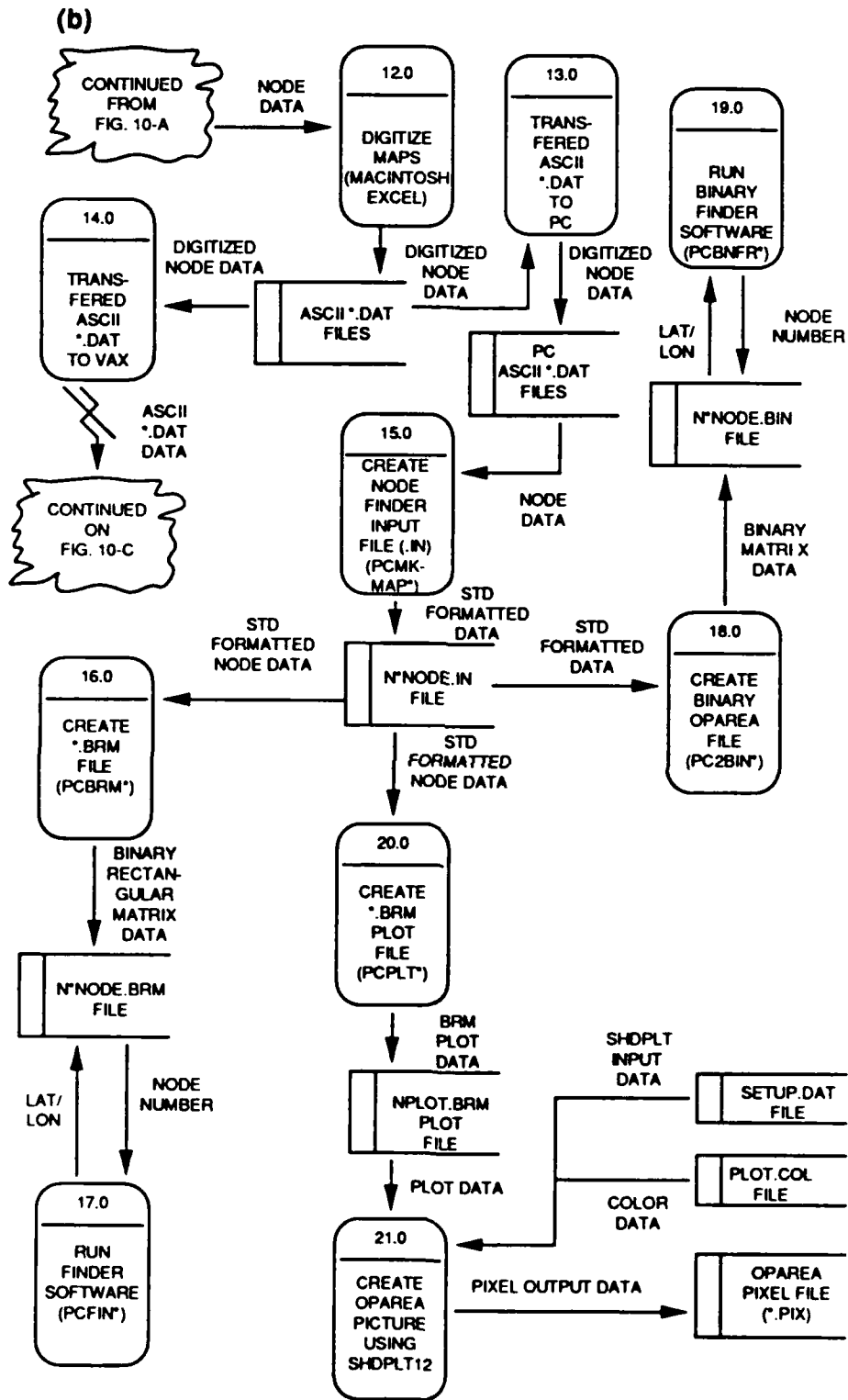

Fig. 10 — (b) TL procedure overview (level 1 continued)

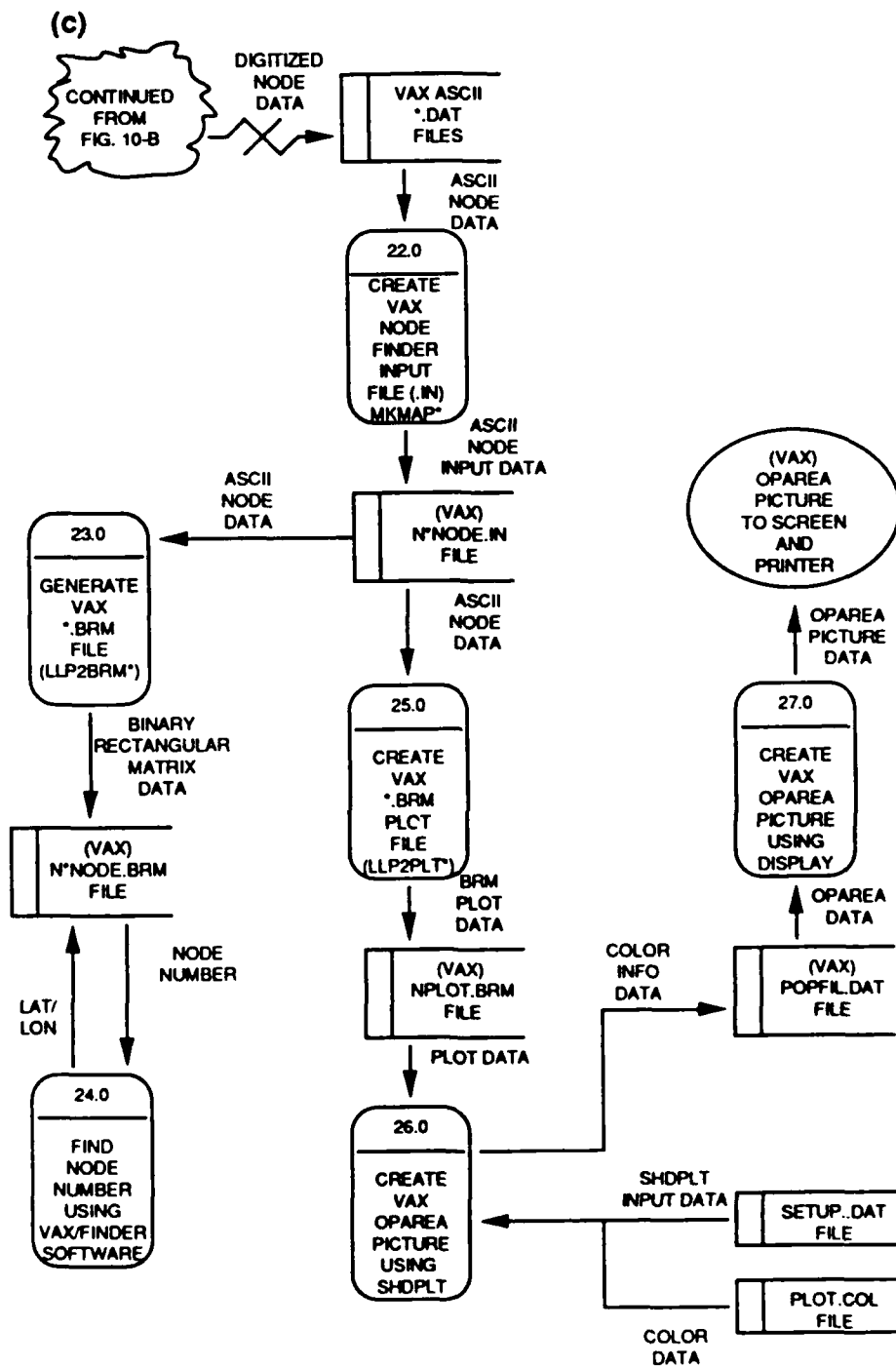

Fig. 10 — (c) TL procedure overview (level 1 continued)

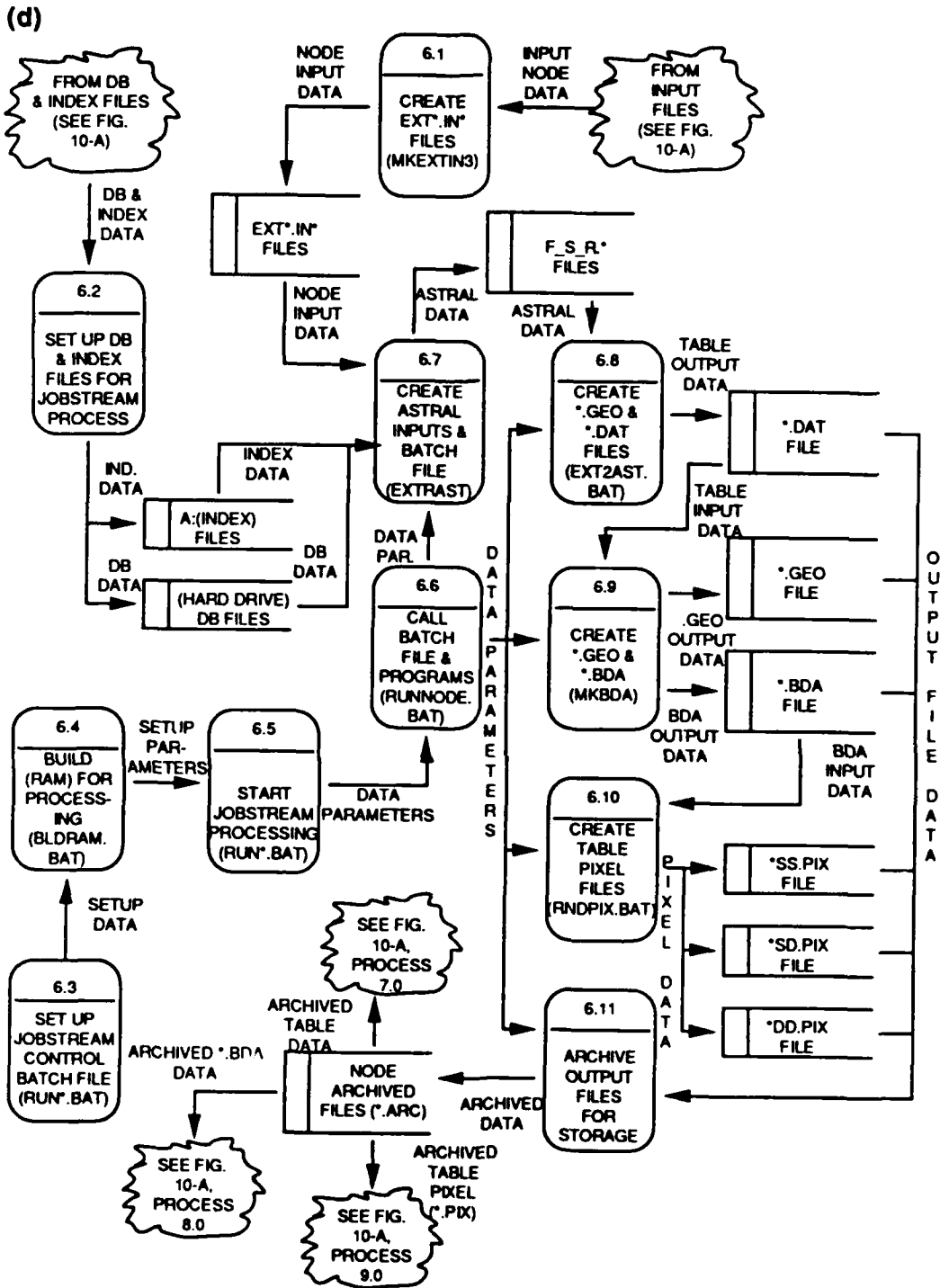

Fig. 10 — (d) Run PC batch/software jobstream TL procedure overview (level 2)

and file input characters. These files are created by the program BLDINPUT. Both summer and winter season files are created for each province. These files will be accessed by the batch/software jobstream to create EXT*.IN* files; by the SVPANA software in the creation of the Sound Velocity Profile Analysis file; and by the TSTDTH2 software to test inputs for a proper depth.

6.2 Extracting Environment Databases

The database information is extracted after the ocean OPAREAs are determined. Using INGRES/EXTRACT software (Fig. 10a, Process 3.0), database information is extracted from the Navy-standard databases (GDEM, BLUG, DBDB5 and HFBL).

Once the database information has been extracted and formatted into ASCII data files (Fig. 10a, Process 4.0), they are then transferred, via Ethernet, to the PC ASCII data files. The data files are then accessed by program CREATEDB in the creation of PC databases and index files (Fig. 10a, Process 5.0). The database and index files will be accessed by the batch/software jobstream to extract acoustic environment data to be used in the creation of jobstream output files. The SVPANA software will also extract data from the GDEM database and index files to produce the SVPANA file.

6.3 Batch/Software Jobstream Processing

6.3.1 Setting Up Jobstream

Batch/software jobstreams are set up on several PC workstations to run nodes in the various OPAREAs. The jobstream input files (EXT*.IN*), the database/index files, and the batch control run file (RUN*.BAT) must all be set up before a jobstream can be started.

The jobstream input files (EXT*.IN*) are created by MKEXTIN (Fig. 10d, Process 6.1) with data from the Input Deck (.IN) files (Fig. 10a, Process 2.0). After the Input Deck (*.IN) files have been created, the depths are tested by using program TSTDTH2 to verify that they are correct for extraction from the environment databases (Fig. 10a, Process 3.0). The database files are set up on the hard drive according to the PC workstation configuration (Fig. 10d, Process 6.2). The index files are modified to access the databases on the hard-drive and stored on a disk. A batch control run-file (RUN*.BAT) is set up from a generic sample file (Fig. 10d, Process 6.3). The parameters within this user-prepared control file are modified to reflect the OPAREA nodes and the PC workstation configuration. Once the setup files are complete, RAM must be set for the specific PC workstation (Fig. 10d, Process 6.4). BLDRAM.BAT sets up the RAM disk in preparation for processing to build TL databases.

6.3.2 Jobstream Execution

Processing is started by initiating the batch control run-file, RUN*.BAT. The parameters for each node to be processed are passed to the RNDNODE.BAT (Fig. 10d, Process 6.6). The RNDNODE.BAT program, in turn, controls all processing for the current node, by calling the remaining batch/program software, producing at the end of a successful run an *.ARC file containing the *.DAT, *.BDA, *.GEO, and *.PIX output files.

The EXTRAST program (Fig. 10d, Process 6.7) is called, first to create a series of ASTRAL model input files, by extracting from the set databases (GDEM, BLUG, DBDB5, AND HIFREQ)

along a great circle path radial track. It also takes inputs from the EXT*.IN* files created earlier by MKEXTIN. This program generates a track for each radial from a point (36 radials using a 10° increment). For each radial, 6 F_S_R.* (frequency-source-receiver) files are created (Fig. 11) for a total of 216 F_S_R.* files (36 radials × 6 combinations) allowing the execution of various combinations of frequencies, source depths, and receiver depths.

EXT2AST.BAT (Fig. 10d, Process 6.8) is then called by RNDNODE. It controls processing for each ASTRAL model radial created by EXTRAST. EXT2AST calls RND CZ.BAT, the program that runs the ASTRAL model and postprocesses the TL table. This program is called 36 times for each point. Postprocessing of ASTRAL output (Fig. 11) in this program consists of reformatting the linear interpolation to determine the TL values by calling TLINTP. Program COMBINE is called to create the table (file) of Range-TL data for each of the three geometries and for all eight frequencies. The tables (files) are then "directed," concatenated, into MKBDA.IN, thus creating a large ASCII data file that holds data for all 36 radials, three geometries, and eight frequencies. This data file is later renamed and archived as the *.DAT file. The data in this file is copied to MK3.IN and used as input by MKBDA.

At this point in the jobstream, RNDNODE calls MKBDA (Fig. 10d, Process 6.9). MKBDA packs the ASCII output of EXT2AST into a binary direct access (*.BDA) formatted file for rapid retrieval of the data. This program also produces an ASCII file of the output model geometries (*.GEO).

Once the *.BDA file has been created, RNDNODE calls RNDPIX.BAT (Fig. 10d, Process 6.10). RNDPIX controls the processing of the creation of the table pixel files (*.PIX). This program calls MKTABFLS.BAT eight times (number of frequencies) for each of the three geometries. MKTABFLS then, in turn, calls BDA2TBL, which creates a (*.BRM) file for each geometry/frequency combination and outputs a combination of 24 files. BRMQP is called by RNDPIX (Fig. 11) to read the 24 *.BRM files and combines them into one *.BRM file for use by SHDPLT12. SHDPLT12 is then called to generate the PIXEL (*.PIX) files (Fig. 12).

6.3.3 Postprocessing

Throughout the jobstream process, the output files that have been created are stored in an output archive file. The archive file is named according to the database type, OPAREA, the node number, the season being processed, and the file type (*.ARC). These archive files are then used by the other software to produce output for delivery (Fig. 10a, Process 8.0) and also for Quality Control (Fig. 10a, Process 10.0).

6.3.4 Grid Pixel Software

The grid pixel software uses the *.BDA file created during the jobstream to generate grid pixel files (Fig. 10a, Process 9.0). This software produces 24-grid pixel files (Fig. 13), a file for each of the three geometries and eight frequencies combinations. The pixel files are named according to the ocean, node number, season, geometry, and frequency. The pixel files are then archived to be used when performing quality control/analysis (Fig. 10a, Process 10.0).

6.3.5 Digitize Charts

The node OPAREAs created earlier (see Sec. 6.1) are digitized manually by using Microsoft Excel. The digitized ASCII files (charts) are transferred to the VAX and PCs and are used to create files that are plotted and accessed by the node locator (FINDER) software.

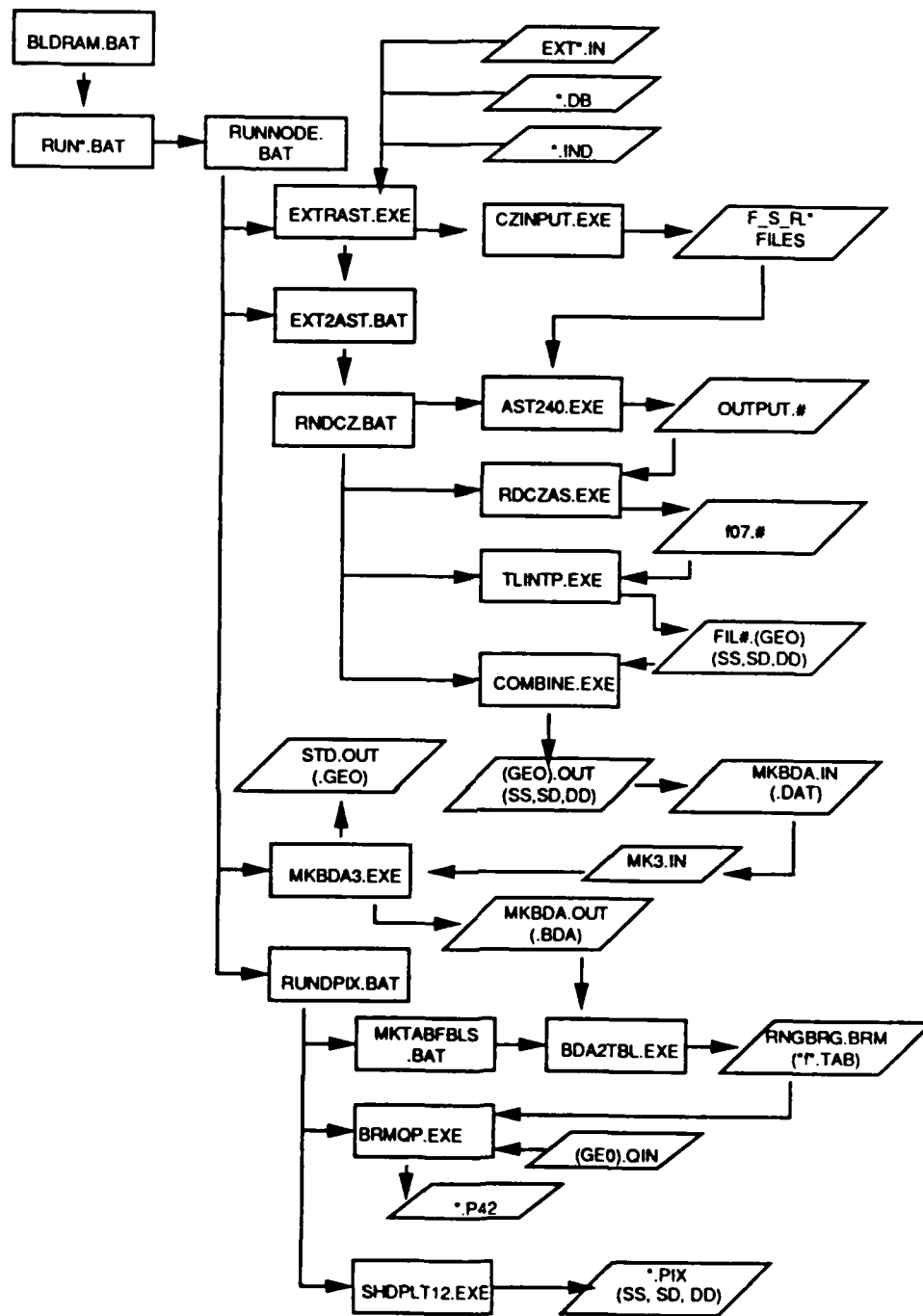

Fig. 11 — Software overview PC batch/software jobstream program flow diagram

6.4 Quality Analysis/Control

Quality control analysis (Fig. 10a, Process 10.0) is performed by viewing the output table pixel files (Fig. 12) created within the jobstream and also by viewing the grid pixel files (Figs. 3, 4, and 13) created by running the GRID PIXEL software. By viewing these various graphic output files, the TL database is qualitatively analyzed for gross errors, and failures are

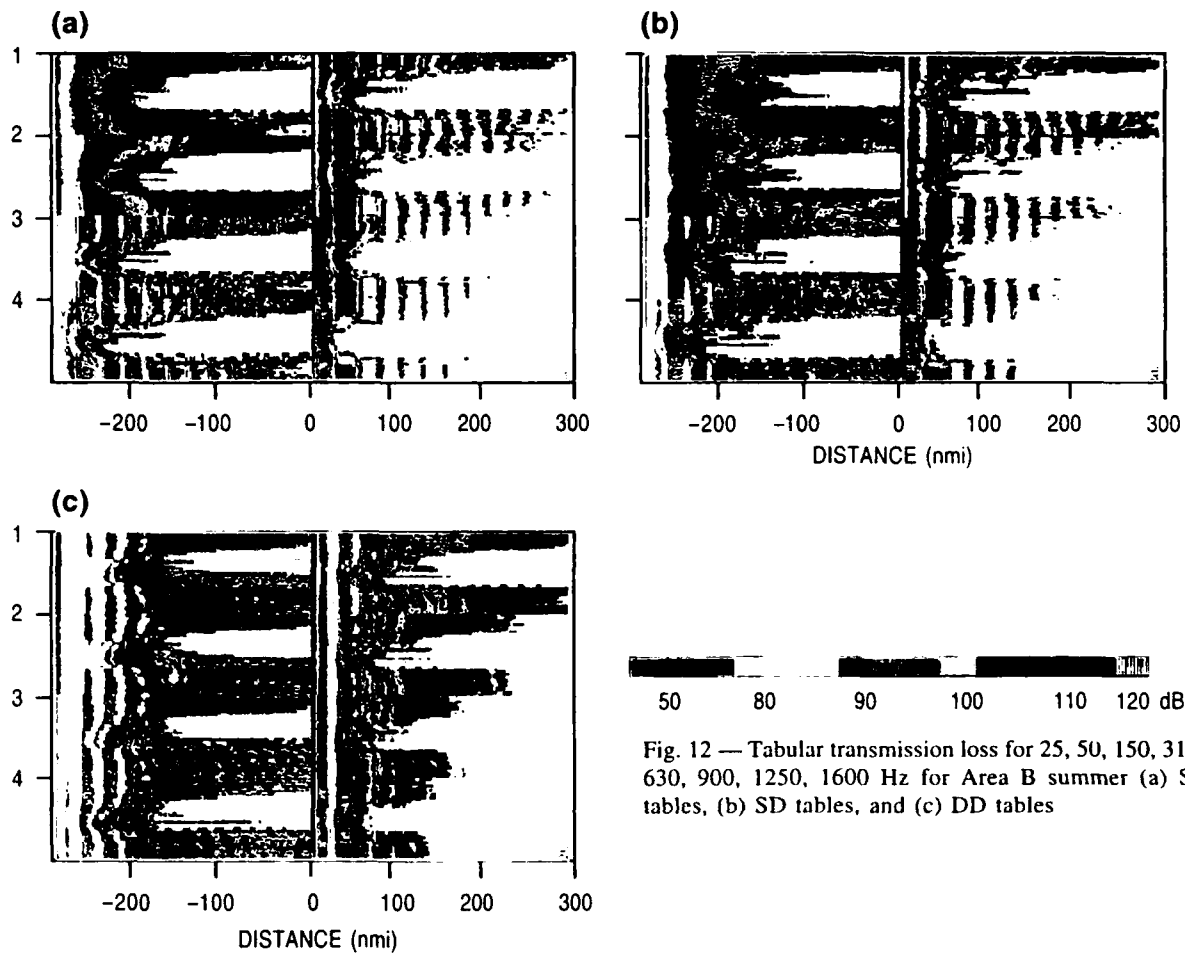

Fig. 12 — Tabular transmission loss for 25, 50, 150, 315, 630, 900, 1250, 1600 Hz for Area B summer (a) SS tables, (b) SD tables, and (c) DD tables

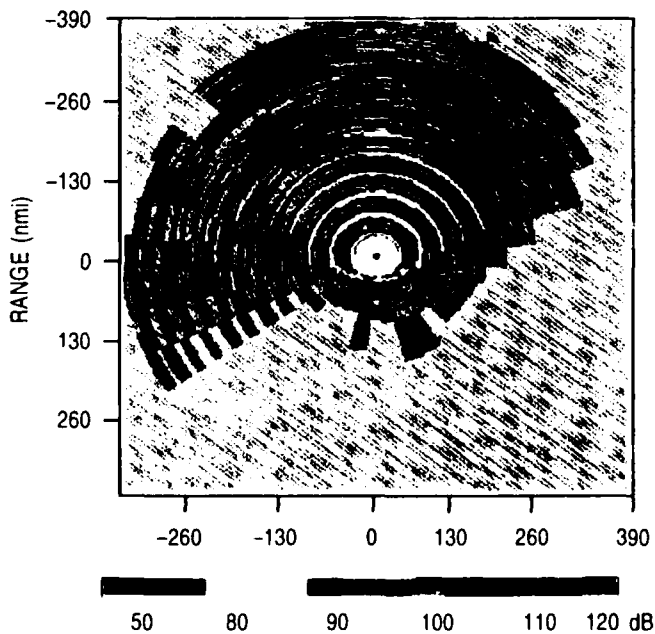

Fig. 13 — Radial display grid, transmission loss for Area B summer SS 150 Hz

easily determined. An individual table picture depicts all eight frequencies for a particular source/receiver depth geometry (Fig. 12), and an individual grid picture displays only one frequency in radial form (Fig. 13). All of these graphics can be plotted as hardcopy or viewed on screen either individually or in a continuous loop (movie) format using program DISGRAF2.

7.0 SOFTWARE OVERVIEW

To develop the NRaD CMAS database, the utility processing programs listed below were developed, coded, and utilized for this project. Products that are used on the VAX computer are identified by the (VAX) suffix to the program name.

AST240 is the Navy-standard range-dependent passive acoustic TL model.

BDA2BRM reformats a BDA file containing all frequencies and depth geometries to a particular depth geometry and frequency in a binary rectangular format (BRM) for use in a graphics package.

BDA2TBL creates a *.BRM file for each geometry-frequency combination and outputs a combination of 24 files to be combined into one *.BRM file by BRMQP.EXE.

BLDINPUT creates the node input deck files (*.IN). These files contain standard node information that is used in the jobstream setup and by various other programs.

BLDRAM creates the necessary directories and copies the files needed for processing. Part of the setup process for running the NRaD range-dependent TL processing in random access memory.

BRMQP reads a series of *.BRM files created by BDA2TBL and places them into one *.BRM file to be used by SHDPLT12 to display.

COMBINE produces a table/file that contains outputs of two different ASTRAL runs using identical depth geometry, but two different sets of four frequencies per run.

CREATEDB creates a data set direct access file to be used as input for the radial extract program.

DISGRAF2 is a graphics display engine that can recall saved pixel files generated by SHDPLT12 either individually or in a continuous movie loop.

EXT2AST is created by EXTRAST. Coordinates the ASTRAL model runstream as determined in the node input menu files (RNDCZ.BAT). Output is a large ASCII file containing the TL values (*.DAT).

EXTRACT (VAX) accesses and retrieves Navy-standard database information using the relational database management system software (INGRES).

EXTRAST creates a series of ASTRAL model input files by extracting sound speed, BLUG and HFBL bottom loss, and bottom depth along great circle path sections, and creates the runstream file to execute the ASTRAL.

GEOFRQLP.BAT is a batch program that receives the specific node parameters to generate a different geometry and frequency to be passed to MKGRDPIX.BAT.

GETRNO is used by GETSTL and GETRTL to compute appropriate record number in the *.BDA file.

GETRTL is a subroutine to get the entire RADIAL TL.

GETSTL is a subroutine to access *.BDA and return a single TL value from a radial.

GETTL (VAX) is a routine to return TL information for a particular node file.

LL2NOD* (VAX) is a routine to return the node number for a particular LAT/LON within the OPAREA BRM.

LLP2BRM* (VAX) creates an OPAREA Binary Direct Access file (OPAREA BRM) file used by the node locator subroutines.

LLP2PLT* creates an OPAREA Binary Direct Access (*.BRM) plot file. This file will be inputted into the color shading plot program to create a picture of the OPAREA Node locations.

MKBD A (VAX) packs the ASCII output transferred from the PC (*.DAT file) into a binary direct access (BDA) formatted file for rapid retrieval of data.

MKBD A packs the ASCII output of EXT2AST into a binary BDA formatted file for rapid retrieval of data (*.BDA). MKBD A also creates an ASCII file of the output model geometries (*.GEO).

MKBRMPC reformats an ASCII digitized chart of the OPAREA defining the limits of each node subarea into a BRM form to be read by the node locator program.

MKEXTIN builds the individual node input parameter menu files.

MKGRDPIX.BAT is a batch program that takes the passed parameters and creates a GRD/PIX.PIX file for a specific node, geometry, and frequency.

MKMAP* (VAX) creates an input file of all i, j node assignments for a particular OPAREA. Output is an ASCII digitized chart.

MKTABFBLS is called multiple times by RNDPIX.BAT to run BDA2TBL.EXE in creating the *.BRM file. For each call, the command line replaceable parameters to specify the geometry and frequency desired.

PC2BIN* creates an OPAREA binary file (*.BIN) for the PC. This file is created per request of customer and will be used by the PC binary node locator program.

PCBNFR* is the Binary PC node FINDER program. This routine reads a binary (*.BIN) file to return a node number for a particular LAT/LON within a specific OPAREA.

PCBRM* creates an OPAREA binary rectangular matrix (*.BRM) for the PC. This file will be used by the PC node locator (FINDER) program (PCFIND*).

PCFIND* is the PC Node Finder program; returns a node number on the PC for a particular LAT/LON within a specific OPAREA.

PCMAP* creates a PC input file (*.IN) in standard shade plot format for a specific ocean OPAREA. This OPAREA input file will be used to create a PC binary rectangular matrix (*.BRM).

PCPLT* creates an OPAREA binary rectangular matrix (OPAREA *.BRM) plot file for the PC. This file is inputted into the color shading plot program to create a picture of the OPAREA Node locations.

RDCZAS reformats the ASCII TL output file from AST240 into the VAMPNET standard output format.

RNDCZ is a batch file that coordinates the intricate details of the ASTRAL model and output formatting programs.

RNDNODE.BAT controls all the processing for the currently running node, producing an ARCHIVE (ARC) file containing the ASCII output (DAT), the Binary Direct Access (BDA) formatted output, model geometry (GEO) and pixel file (PIX) outputs.

RNDPIX is a driver program to create Quality Analysis graphics and save them in pixel files that can be displayed at a later date for quality control of the final product. Graphics are in tabular format.

RUN*.BAT coordinates the execution of RNDNODE.BAT for each node point in the OPAREA.

RUNPIX creates individual graphics of each frequency and depth geometry in RADIAL format for specialized display.

RUNPIX.BAT is a setup batch program for the GRD/PIX jobstream. It is edited for specific parameters, then passes these parameters to the GEOFRQLP.BAT.

SHDPLT (VAX) is a color or contour display package using DISSPLA routines to graphically display an i-by-j binary matrix of data.

SHDPLT12 was originally developed on the VAX as a color display of an i-by-j binary matrix of data. The PC version can save pixel files for future display.

SVPANA analyzes the starting GDEM sound velocity profile producing information such as sonic layer depth, deep sound channel axis, critical depth, depth excess and half-channel conditions.

TLINTP uses linear interpolation to determine the TL output values between the TL input values and outputs TL at the desired range points.

TSTDTH2 tests the program EXTRAST ability to extract the starting environments from DBDB5 and GDEM databases. It also can adjust the deep depth geometry to conform to near bottom condition (~10 m less than bottom depth) in shallow node locations.

8.0 RETRIEVAL SOFTWARE

8.1 Node Locator (FINDER) Software

This software operates on the VAX and PC computers. The digitized ASCII files are used on both VAX and PC computers to generate a node input file to be accessed by the Node Locator (FINDER) Software. The FINDER Software and other associated programs are modified to run in each ocean area. The input (*.IN) file is created by running PCMKMAP* (Fig. 10b, Process 15.0) on the PC, and MKMAP* (Fig. 10c, Process 22.0) on the VAX.

On the PC, the node input file is used to create a binary rectangular matrix file (*.BRM) (Fig. 10b, Process 16.0). The *.BRM file is accessed while running the FINDER Software (Fig. 10b, Process 17.0); a latitude and a longitude are given as input, and a node number is returned as output. The PC node input file is used to create a binary OPAREA file, *.BIN (Fig. 10b, Process 18.0). The *.BIN file is accessed by running the Binary Finder software (PCBNFR*). The PCBNFR* Finder software runs the same as the FINDER software. It is given a latitude and a longitude as input; it returns a node number as output. The PC node input file is also used in the creation of the OPAREA picture (Fig. 5) file. First, a binary plot file (NPLOT.BRM) is created (Fig. 10b, Process 20.0). The plot file is then used as input, along with a setup data file and a plot color file, by SHDPLT12 (Fig. 10b, Process 21.0) to create the OPAREA pixel (*.PIX) file.

On the VAX, the node input file is used to create a VAX Binary Rectangular Matrix file (*.BRM), (Fig. 10c, Process 23.0). The *.BRM file is accessed by the VAX FINDER software (Fig. 10c, Process 24.0). The VAX FINDER works the same as the PC FINDER. The node input file on the VAX is also used to create the VAX OPAREA picture (Fig. 5). A VAX *.BRM plot file is created (Fig. 10c, Process 25.0). This file, along with a setup data file and a plot color file, is then used by the VAX SHDPLT program (Fig. 10c, Process 26.0) to create a data file (POPFIL.DAT) that in turn is used as input to run DISSPLA (Fig. 10c, Process 27.0) that creates the OPAREA picture that is sent to the screen and the printer.

9.0 ACKNOWLEDGMENTS

As users of acoustic modeling technology, we are indebted to many who have worked in this field. This particular project was very computationally intensive, so we particularly wish to acknowledge the contributions of the computer scientists and the analysts who have supported this project. The extensively modified batch job control software scheme was originally developed by Ms. M. A. Hebert of Planning Systems Inc.; she also had a key role developing the radial extract program. Other major portions of executable software were written by Dr. D. B. King (NRL), provided ASTRAL modifications; Mr. J. C. Campbell and Ms. M. L. Ling (NRL), wrote interpolation and formatting routines; Mr. M. R. Fernandez (PSI) developed the retrieval software, the quality control programs, and many of the screen displays; Mr. J. Egloff (NRL) generated the planning charts; and Ms. J. C. Rapp (NRL) contributed extensive program modifications. Mr. C. C. Wilcox (Commander Naval Oceanography Command) contributed several of the analysis techniques.

This work was funded by the Naval Command, Control and Ocean Surveillance Center, RDT&E Division, Mr. Robert L. Brandenburg, CMAS Project Manager, under program element 0604270N. It has indeed been a pleasure working with Mr. Brandenburg.

10.0 REFERENCES

- Boston, M. A., "TESS 87-09 Program Performance Specification for the Sound Speed Profile Module," Naval Oceanographic Office, July 1987.
- Kerr, G. A., G. P. Cloy, M. A. Hebert, and M. R., Wooten, "Environmental Acoustic Tactical Support Oceanographic Data Module Users Guide," Naval Research Laboratory, Stennis Space Center, MS, NOARL Technical Note 7, January 1990.
- Northridge, B. W., "A Recommended Approach to Sonar Model Design," Naval Postgraduate School, Monterey, CA, December 1990.
- Rapp, J. C., "Vampnet Software System, An Overview," Naval Research Laboratory, Stennis Space Center, MS, NORDA Special Project Document SP 008:224:88, December 1987.
- Soileau, J. V., "NORDA Warfare Effectiveness Study—Transmission Loss Database Extraction Software," Naval Research Laboratory, Stennis Space Center, MS, NORDA SP 022:224:88, March 1988.
- Wilcox, C. C., R. E. Delgado, "NORDA Warfare Effectiveness Study—Transmission Loss Database for Sonobuoy Placement Simulations," Naval Research Laboratory, Stennis Space Center, MS, SP 023:224:88, March 1988.
- Wooten, M., M. L. Fernandez, and M. L. Ling, "Operators Manual & Programmer Documentation," Naval Research Laboratory, Stennis Space Center, MS, SP 001:224:88, December 1987.

APPENDIX

DESCRIPTION OF THE APPLICATION OF RECIPROCITY

Reciprocity is a phenomenon of wave propagation that is usually introduced to students in undergraduate physics courses. For the purposes of this project, the concern is whether or not model results can be shown to reflect the principle of acoustic reciprocity, especially since all numerical acoustic models contain approximations. It is accepted practice in the acoustic modeling community to use this technique to help validate models (F. Jensen and W. Kuperman, "Consistency Test for Acoustic Propagation Models," SACLANT Center Memo SM-157, March 1982). The technique involves running a model from point 1 to point 2, then running the model from point 2 to point 1, then comparing the output. In keeping with the definition of reciprocity, the comparison need only match at the range equal to the distance between points 1 and 2. How well they compare is, in a sense, a measure of how "good" the model is. It would be more accurate to say, however, that a reciprocity test is a measure of how consistent the model treats the environment.

There are important qualifications in the use of this technique. The more obvious deals with source/receiver geometries. Assume in the initial model run that the source (at point 1) is shallow and that the receiver (at point 2) is deep. When making the model run in the reverse direction, the new source (at point 2) must remain deep, and the new receiver (at point 1) must remain shallow. The more subtle consideration is that both the source and receiver must be assumed to be omnidirectional.

Given that this technique is accepted as an indicator of how consistent a model is, studies demonstrating how well particular models have preserved reciprocity are not uncommon. An example is an article by T. Nghiem-Phu and F. Tappert ("Modeling of reciprocity in the time domain using the parabolic equation method," J. Acoust. Soc. Am., July 1985) in which they conclude that their results confirm that the PE model is accurately reciprocal. A similar model study using ASTRAL could not be found. (Recall that the Navy-standard ASTRAL model was used to build the CMAS TL database). On the one hand, ASTRAL has the reputation of being a high-speed model that uses a lot of approximations; on the other, the internal logic of the model makes specific use of reciprocity. These factors suggest that a model study investigating reciprocity with ASTRAL is a worthwhile endeavor.

During the effort to construct this database (which would require millions of model runs), we knew that any chance to be more efficient was worth pursuing. Given that even the simplest of

simulations should include depth dependence for both the target and the sensor, four was the minimum number of source-receiver geometries required:

- (1) Shallow-Shallow (SS)
- (2) Shallow-Deep (SD)
- (3) Deep-Shallow (DS)
- (4) Deep-Deep (DD)

We chose to run the first, second, and fourth geometries, and we devised a way to represent the DS geometry by invoking reciprocity using the data from the SD case. By using this technique, we've had to run "only" 6 million TL calculations instead of 8 million.

To demonstrate this technique we selected a node at random. Figure A1 shows our sample point (Node 32) off the East Coast of the U.S. The CMAS database contains files for that node (as it does for every other node) giving TL at one nautical mile increments out to 300 nmi for 36 radials. (In Figs. A1 and A2, a circle with a 300 nmi radius is drawn.) This "wagon-wheel" of data is repeated for the three selected source-receiver geometries and for eight frequencies. Figure A2 depicts the other 40 nodes that are within 300 nmi of Node 32.

Let us set a scenario where an OMNI buoy at a shallow depth is located at the same latitude/longitude as that which represents Node 32. Let us suppose a deep target is 75 nmi to the northwest (and that its latitude and longitude are the same as Node 45). The TL data needed for this case would be pulled from File 32, second (SD) column. If the OMNI buoy at Node 32 was a deep sensor and the target 75 nmi to the northwest was a shallow target, there would be no corresponding data within File 32. Instead, the second (SD) column in File 45 (for the reciprocal bearing) would be used to provide the data.

No particular purpose would be served by citing the TL values for the cases just described. They need not match because these are not reciprocal cases. The SD column of numbers in File 45 would need to be compared to DS numbers from Node 32. And these are precisely the numbers that were not computed (to save time/space in constructing the database).

To test for reciprocity with ASTRAL using this CMAS database, we would have to use the data in a manner for which they were not intended. Given the scenario above, this time we would fix the sensor-target depths to be the same (i.e., SS and DD). Keep in mind that this is for the purpose of testing ASTRAL's ability to preserve reciprocity, and is quite different from using reciprocity to infer TL values for cases that have not been computed.

First, we list the TL values computed from Node 32 out 75 nmi in the direction of Node 45 (for the lowest five frequencies only, since the higher frequencies show nothing but high loss at long range). We compare them to the TL values from Node 45 out 75 nmi in the direction of Node 32.

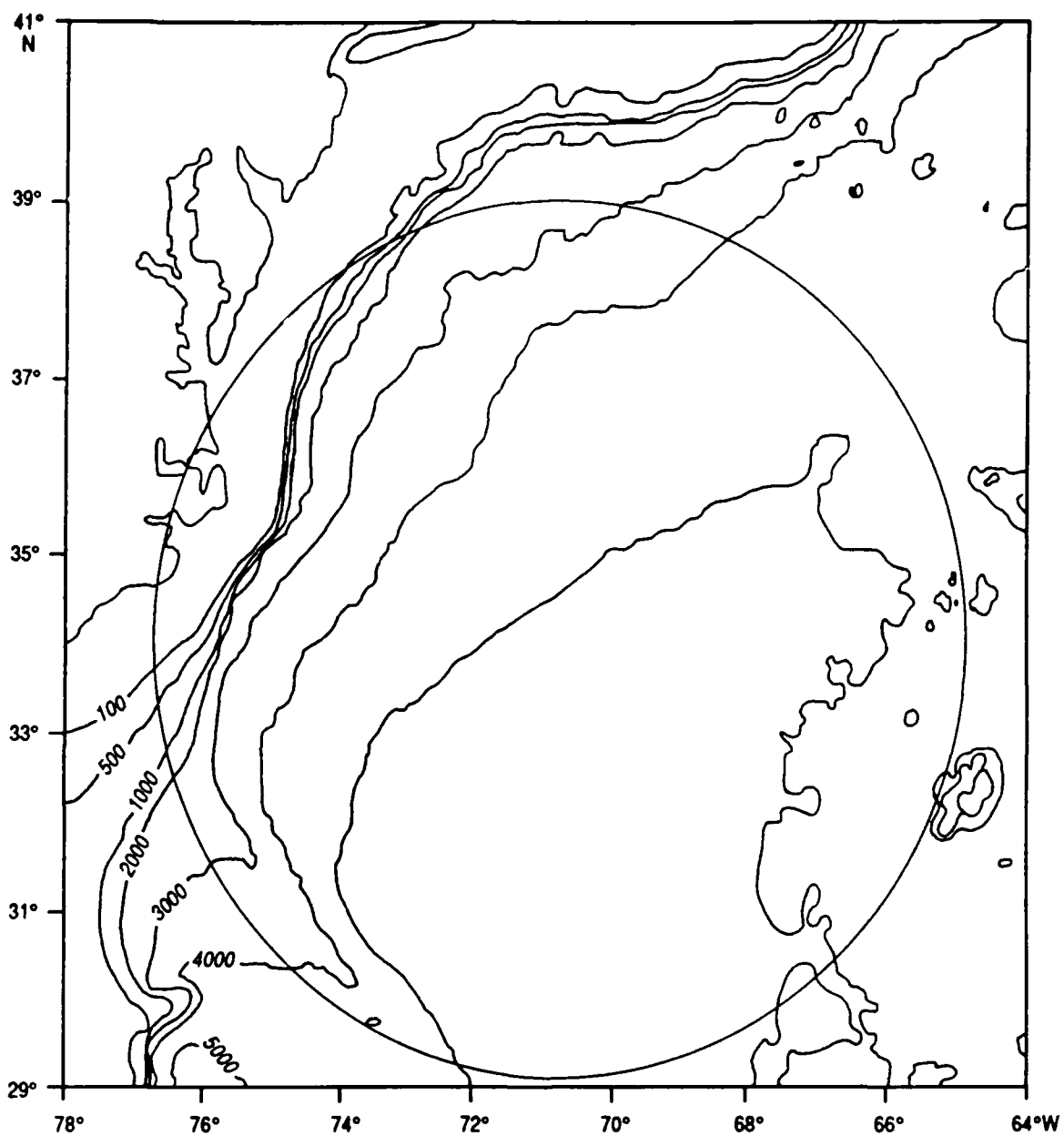

Fig. A1 — Reciprocity study OPAREA, Atlantic Ocean

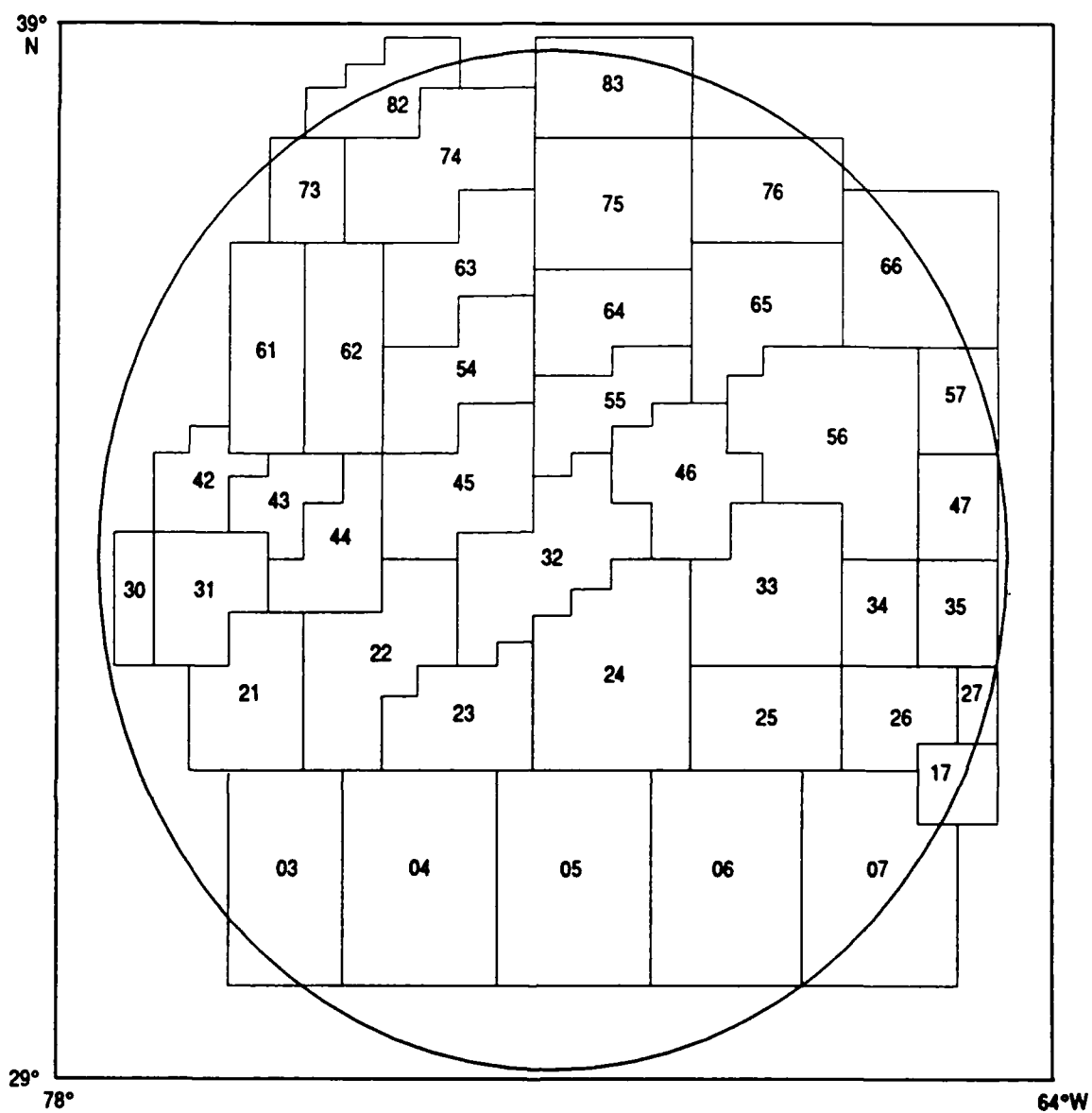

Fig. A2 — Reciprocity study OPAREA

Depth Geometry	Frequency (Hz)	File 32 (dB)	File 45 (dB)
SS	50	97.5	91.0
	150	94.3	94.9
	315	101.0	101.5
	630	107.0	109.5
	900	113.9	117.0
DD	50	92.1	92.0
	150	91.3	91.5
	315	92.1	92.5
	630	95.0	95.5
	900	99.0	99.5

Most of the comparisons show excellent agreement and tend to support the idea that ASTRAL is reciprocal. The SS 50-Hz case, however, appears to be a poor sample case for reciprocity. We reviewed the anomalous cases a little more closely. Aside from the presence of "engineering patches" in ASTRAL that "fix" perceived weaknesses in the model, the fact that ASTRAL takes fairly long range steps while computing radial TL is a likely cause of mismatches. Relaxing our criteria in that dimension, we find that less than 2 nmi away these two TL curves intersect. This greatly influences our criteria for determining if/when the comparisons support the idea that ASTRAL is reciprocal.

With five frequencies, two geometries, and 40 nodes within 300 nmi of Node 32, our sample set contained 400 comparisons. For some of them, the comparisons were at such a distance that the TL curves had already hit the arbitrary "floor" of 150 dB. Twenty-five cases of this type were removed from the sample set. The remaining 375 were graded on how close they compared (1) in decibel space at the range equal to the distance between nodes, and/or (2) in nautical miles distant from that range to where the TL curves intersected. Figure A3 reveals that ASTRAL achieves an excellent score on this test. Describing the axes in other terms, we can say that, on this test (which is not a particularly easy test considering the bathymetric relief), 51% of the class received an A; 20% got a B; 15% got a C. These numbers are impressive (86% within 3 dB). On the borderline, 9% got a D; 4% received a D minus. Only 1% failed the reciprocity test.

Two results were achieved by this effort. First, the anomalous cases can now be easily identified. After bringing these to the attention of the ASTRAL model developers, further improvements may be forthcoming. Second, the success of this study influences future design. Reciprocity may be a "permanent" feature of this database.

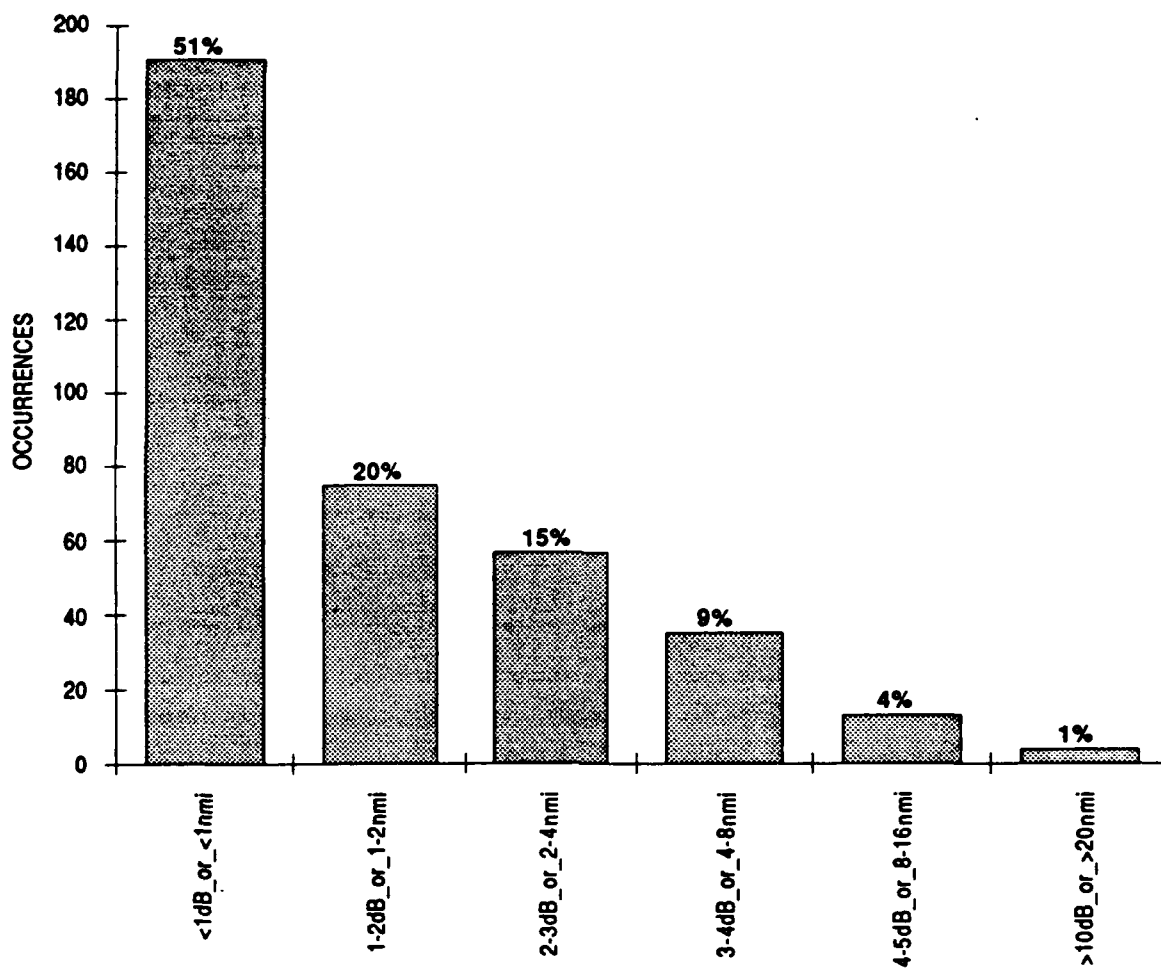

Fig. A3 — Reciprocity categories = 375