



**US Army Corps
of Engineers**
Construction Engineering
Research Laboratories

AD-A269 559



USACERL Technical Report FE-93/22
May 1993
Clean Electric Power Technologies

(2)

Effects of Harmonics on EMI/RFI Filters Operating Under Nonlinear Loading Conditions

DTIC
ELECTE
SEP 22 1993
S A D

by
Steve J. Briggs
Michael S. Kim
Franklin H. Holcomb

Electromagnetic interference/radio frequency interference (EMI/RFI) power-line filters are widely used in the Army for filtering unwanted signals on power lines serving sensitive equipment, particularly computers and communication gear. Typically, these loads are highly nonlinear and cause severe harmonic loading on the filters. Harmonics cause filter failure and shortened filter lifetimes. The objective of this research was to quantify the effects of harmonics and nonlinear loads on EMI/RFI filters and to recommend a derating factor for EMI/RFI filters in nonlinear load applications.

EMI/RFI filters were purchased and placed in an experimental apparatus with a known source of harmonics. The filters were instrumented, and temperature data was recorded. A mathematical model of the filters was developed, and simulations were performed to predict filter failure.

The results of the research indicate that filter ampacity should be derated by 50 percent for filters that are being specified for nonlinear loading applications.

Approved for public release; distribution is unlimited.

9 3 9 21 041

93-21929



The contents of this report are not to be used for advertising, publication, or promotional purposes. Citation of trade names does not constitute an official endorsement or approval of the use of such commercial products. The findings of this report are not to be construed as an official Department of the Army position, unless so designated by other authorized documents.

DESTROY THIS REPORT WHEN IT IS NO LONGER NEEDED

DO NOT RETURN IT TO THE ORIGINATOR

USER EVALUATION OF REPORT

REFERENCE: USACERL Technical Report FE-93/22, *Effects of Harmonics on EMI/RFI Filters Operating Under Nonlinear Loading Conditions*

Please take a few minutes to answer the questions below, tear out this sheet, and return it to USACERL. As user of this report, your customer comments will provide USACERL with information essential for improving future reports.

1. Does this report satisfy a need? (Comment on purpose, related project, or other area of interest for which report will be used.)

2. How, specifically, is the report being used? (Information source, design data or procedure, management procedure, source of ideas, etc.)

3. Has the information in this report led to any quantitative savings as far as manhours/contract dollars saved, operating costs avoided, efficiencies achieved, etc.? If so, please elaborate.

4. What is your evaluation of this report in the following areas?

a. Presentation: _____

b. Completeness: _____

c. Easy to Understand: _____

d. Easy to Implement: _____

e. Adequate Reference Material: _____

f. Relates to Area of Interest: _____

g. Did the report meet your expectations? _____

h. Does the report raise unanswered questions? _____

i. General Comments. (Indicate what you think should be changed to make this report and future reports of this type more responsive to your needs, more usable, improve readability, etc.)

5. If you would like to be contacted by the personnel who prepared this report to raise specific questions or discuss the topic, please fill in the following information.

Name: _____

Telephone Number: _____

Organization Address: _____

6. Please mail the completed form to:

Department of the Army
CONSTRUCTION ENGINEERING RESEARCH LABORATORIES
ATTN: CECER-IMT
P.O. Box 9005
Champaign, IL 61826-9005

REPORT DOCUMENTATION PAGE

**Form Approved
OMB No. 0704-0188**

Public reporting burden for this collection of information is estimated to average 1 hour per response, including the time for reviewing instructions, searching existing data sources, gathering and maintaining the data needed, and completing and reviewing the collection of information. Send comments regarding this burden estimate or any other aspect of this collection of information, including suggestions for reducing this burden, to Washington Headquarters Services, Directorate for Information Operations and Reports, 1215 Jefferson Davis Highway, Suite 1204, Arlington, VA 22202-4302, and to the Office of Management and Budget, Paperwork Reduction Project (0704-0188), Washington, DC 20503.

1. AGENCY USE ONLY (Leave Blank)	2. REPORT DATE May 1993	3. REPORT TYPE AND DATES COVERED Final	
4. TITLE AND SUBTITLE Effects of Harmonics on EMI/RFI Filters Operating Under Nonlinear Loading Conditions		5. FUNDING NUMBERS 4A162784 AT45 EX-XF3	
6. AUTHOR(S) Steve J. Briggs, Michael S. Kim, and Franklin H. Holcomb		8. PERFORMING ORGANIZATION REPORT NUMBER TR-FE-93/22	
7. PERFORMING ORGANIZATION NAME(S) AND ADDRESS(ES) U.S. Army Construction Engineering Research Laboratories (USACERL) P.O. Box 9005 Champaign, IL 61826-9005		9. SPONSORING/MONITORING AGENCY NAME(S) AND ADDRESS(ES) U.S. Army Engineering and Housing Support Center (USAEHSC) ATTN: CEHSC-FU-E Building 358 Fort Belvoir, VA 22060-5516	
11. SUPPLEMENTARY NOTES Copies are available from the National Technical Information Service, 5285 Port Royal Road, Springfield, VA 22161			
12a. DISTRIBUTION/AVAILABILITY STATEMENT Approved for public release; distribution is unlimited.		12b. DISTRIBUTION CODE	
13. ABSTRACT (Maximum 200 words) Electromagnetic interference/radio frequency interference (EMI/RFI) power-line filters are widely used in the Army for filtering unwanted signals on power lines serving sensitive equipment, particularly computers and communication gear. Typically, these loads are highly nonlinear and cause severe harmonic loading on the filters. Harmonics cause filter failure and shortened filter lifetimes. The objective of this research was to quantify the effects of harmonics and nonlinear loads on EMI/RFI filters and to recommend a derating factor for EMI/RFI filters in nonlinear load applications. EMI/RFI filters were purchased and placed in an experimental apparatus with a known source of harmonics. The filters were instrumented, and temperature data was recorded. A mathematical model of the filters was developed, and simulations were performed to predict filter failure. The results of the research indicate that filter ampacity should be derated by 50 percent for filters that are being specified for nonlinear loading applications.			
14. SUBJECT TERMS electrical distribution systems electromagnetic interference/radio frequency interference (EMI/RFI) filters nonlinear loads		15. NUMBER OF PAGES 42	
17. SECURITY CLASSIFICATION OF REPORT Unclassified		16. PRICE CODE	
18. SECURITY CLASSIFICATION OF THIS PAGE Unclassified		19. SECURITY CLASSIFICATION OF ABSTRACT Unclassified	
20. LIMITATION OF ABSTRACT SAR			

FOREWORD

This research was performed for the U.S. Army Engineering and Housing Support Center (USAEHSC) under project 4A162784AT45, "Energy and Energy Conservation"; Work Unit EX-XF3, "Clean Electrical Power Technology." The USAEHSC technical monitor was Ron Mundt, CEHSC-FU-E.

The research was performed by the Energy and Utility Systems Division (FE) of the Infrastructure Laboratory (FL), U.S. Army Construction Engineering Research Laboratories (USACERL). Part of the work was performed by Naresh Khosla of Enviro-Management & Research, 5415-B Backlick Road, Springfield, VA 22151. The authors would like to thank Scott A. Steele, CECER-FE, for his assistance in performing this work. Dr. David M. Joncich is Chief, CECER-FE. Dr. Michael J. O'Connor is Chief, CECER-FL.

COL Daniel Waldo, Jr., is Commander and Director of USACERL, and Dr. L.R. Shaffer is Technical Director.

CONTENTS

		Page
	SF298	1
	FOREWORD	2
	LIST OF TABLES AND FIGURES	4
1	INTRODUCTION	7
	Background	
	Objective	
	Approach	
	Mode of Technology Transfer	
2	HARMONICS	9
	Background	
	Sources	
	Measurement and Instrumentation	
	Effects	
3	EXPERIMENT	16
	Overview	
	Filter Selection	
	Experimental Apparatus	
	Temperature Results	
	Waveform and Power-Loss Results for Filtron Filter	
4	THEORY	29
	Overview	
	Construction of Filter Model	
	Simulation Results	
5	DISCUSSION, CONCLUSIONS, AND RECOMMENDATIONS	36
	Discussion of Results	
	Conclusions	
	Recommendations	

REFERENCES

Accession For	
NTIS CRA&I	<input checked="" type="checkbox"/>
DTIC TAB	<input type="checkbox"/>
Unannounced	<input type="checkbox"/>
Justification	
By	
Distribution/	
Availability Codes	
Dist	Avail and/or Special
A-1	

38

TABLES

Number		Page
1	Harmonics Measurements for Common Equipment	14
2	Simulated Power Loss in Filter	35

FIGURES

1	Summation of the First 30 Terms in the Fourier Decomposition of a Square Wave	10
2	Simple Nonlinear Circuit	11
3	Current Flow in Simple Nonlinear Circuit	12
4	Current Harmonics From ASD	16
5	Schematic of ARK Filter	17
6	Schematic of Filtron Filter	18
7	Experimental Apparatus	19
8	Data Acquisition System	20
9a	Temperature Rise in Inductor	21
9b	Temperature Rise in C1	22
10a	Line-to-Line Voltage With ASD	23
10b	Line-to-Line Voltage Spectrum With ASD	23
11a	Filter Current Without ASD	24
11b	Filter Current Spectrum Without ASD	24
12a	Filter Voltage Without ASD	25
12b	Filter Voltage Spectrum Without ASD	25
13	Filter Power Spectrum Without ASD	26
14a	Filter Current With ASD	27
14b	Filter Current Spectrum With ASD	27
15	Filter Voltage Spectrum With ASD	28

FIGURES (Cont'd)

Number		Page
16	Filter Power Spectrum With ASD	28
17a	Ideal ARK Frequency Response	30
17b	Ideal Filtron Frequency Response	30
18	Measured Filtron Frequency Response	31
19	Final Model of Filtron Capacitor	32
20	Inductor Test Apparatus	32
21	Final Model of Filtron Inductor	32
22	Final Model of Filtron Filter	33
23	Filtron Modeled Frequency Response	34
24	Simulated Power Loss in Filter for 1-Amp Harmonic Current	34

EFFECTS OF HARMONICS ON EMI/RFI FILTERS OPERATING UNDER NONLINEAR LOADING CONDITIONS

1 INTRODUCTION

Background

Electromagnetic interference/radio frequency interference (EMI/RFI) power-line filters are widely used in the Army for filtering unwanted signals on power lines serving sensitive equipment, particularly computers and communication gear. Typically, these loads are highly nonlinear and cause severe harmonic loading on the filters.

Harmonics are related to nonsinusoidal voltage or currents in the electrical distribution system. These harmonics, instead of occurring at the normal power-line frequency, are at integer multiples of line frequency (the fundamental frequency). In general, any nonlinear load is a source of current harmonics. These loads are generally characterized as "active" loads, as opposed to "passive" loads. Common sources of harmonics include switching-mode power supplies (SMPSs), adjustable-speed drives (ASDs), uninterruptable power supplies (UPSs), and fluorescent lighting. Harmonics are responsible for a wide variety of problems in the distribution system, including (1) excessive currents and voltages in the neutral wire, (2) overheating of transformers, motors, and circuit breakers, and (3) failure of EMI/RFI filters.

EMI/RFI filters are used to control interference produced by radar, computers, radio transmitters and receivers, and by such electrical equipment as motors, generators, and switches. For example, undesired high frequency-signals could interfere with analog telephone circuitry. Other applications cited by filter manufacturers are related to preventing high-frequency interference troubles in electronic circuitry on helicopters and cruise ships. In other cases, filters are "designed to prevent undesired emanation of intelligence from secure communication installations by conducted or radiated RF energy." Typical application areas for these filters are locations where highly confidential information is processed by electronic means. The EMI/RFI filters help to ensure that no restricted information can leave the location in question.

These filters are not designed to filter the harmonic voltages and currents that are present to some extent in most distribution systems. Rather, they are designed to shunt high-frequency signals safely to ground. Nevertheless, such harmonic signals may interact with the filters and to produce undesirable results. One example of this was the excessive ground-to-neutral voltage found in the Defense Intelligence Agency Building 3100. This problem is discussed in U.S. Army Engineering and Housing Support Center (USAEHSC) Report E-90033 (1990). To summarize that case, EMI/RFI filters were installed in the 3-phase wires and the neutral wire of a 3-phase, 4-wire system that served Building 3100. The series impedance of the filters was relatively large, and any neutral current flowing in the neutral filter caused an excessively large voltage drop between the neutral wire and the ground. The neutral current was primarily due to third-harmonic currents associated with nonlinear loading. The problem was eliminated by redesigning the neutral filter so that it had an acceptably low series impedance.

Objective

The objective of this study was to quantify the effects of harmonics on EMI/RFI filters. This information was to be applied in the selection of an appropriate derating factor for EMI/RFI filters operating under nonlinear loading conditions.

Approach

Literature and experts in harmonics were consulted regarding derating factors. EMI/RFI filters and a harmonics source were obtained, and experiments were performed to measure currents, voltages, power loss, and temperature rise in the filters. Measurements were taken on the filters, and models were constructed to simulate the filters under harmonics loading conditions. While the literature search and consultations with experts supported the conclusions obtained by the experiment and theory, these are not discussed at length in this report, but are referenced where appropriate.

Mode of Technology Transfer

The methodology developed in this report should be communicated to the field in a Technical Note.

2 HARMONICS

Background

Any nonsinusoidal periodic voltage or current signal on the power line is an indication that harmonics are present. Harmonics are not noise or random signals. They are reproducible signals caused by equipment on the distribution system. Any periodic, nonsinusoidal voltage or current has harmonics in it. These harmonics, instead of being at the normal power-line frequency, are at integer multiples of line frequency, which is called the fundamental frequency. Harmonics are identified by a number indicating their multiple of the fundamental frequency. For example, the term "third harmonic" indicates a signal with a frequency of three times the power-line frequency (180 Hz in the U.S., 150 Hz in Europe). To comprehend how a 60-Hz signal can be said to contain x percent of fifth harmonic, an understanding of the concepts behind Fourier analysis is necessary. The basic idea is that any periodic signal can be decomposed into a summation of pure sine waves whose frequencies are integer multiples of the fundamental frequency.

In mathematical terms, if $f(t)$ is some periodic function with period T and frequency:

$$\omega = \frac{T}{2\pi}, \text{ then} \quad [\text{Eq 1}]$$

$$f(t) = \sum_{n=0}^{\infty} A_n \sin(n\omega t - \theta_n) \quad [\text{Eq 2}]$$

with A_n a coefficient and A_0 representing the dc component in the signal. θ_n is a phase angle between the various components. A common convention is that $\theta_1 = 0$, that is, the reference for phase equals zero is fundamental. The resulting summation is called the Fourier series decomposition of the signal $f(t)$. Although the summation runs from zero to infinity, in practice the zeroth term (which represents a dc offset) is generally equal to zero, and for most signals, only a few terms are needed to accurately represent $f(t)$. The technique of determining the coefficients A_n , given the signal $f(t)$, is called Fourier analysis. Fortunately, many computer programs and metering instruments will perform that task. Simple example of Fourier decomposition of a signal is to apply the technique to a square wave, obtaining the following formulas for the Fourier series:

$$A_n = \frac{4}{n\pi} \text{ for } n \text{ odd} \quad [\text{Eq 3}]$$

and:

$$A_n = 0 \text{ for } n \text{ even} \quad [\text{Eq 4}]$$

Note that all the even harmonics are identically equal to zero. This is a general property of most signals found in power systems. The first term, A_1 , is the fundamental (or 60-Hz) term. Figure 1 shows the summation for the first 30 terms in the Fourier series. Note how well it reproduces the original square wave. For most power-system signals and problems, the first 30 harmonics are more than adequate to represent a waveform. This breakdown is often referred to as the frequency spectrum of the signal.

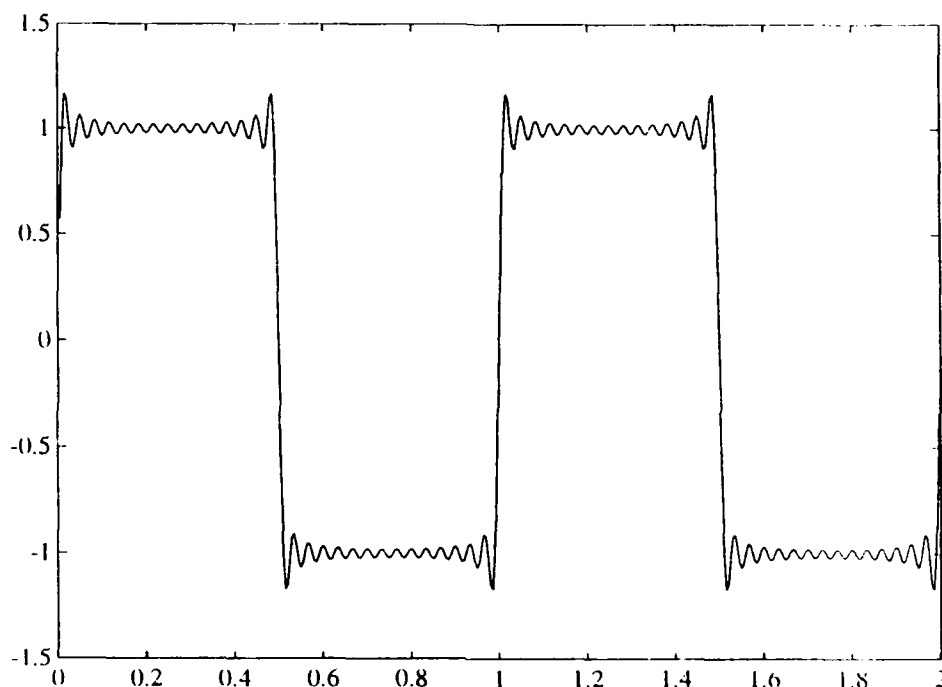

Figure 1. Summation of the First 30 Terms in the Fourier Decomposition of a Square Wave.

Several conventions exist for measuring harmonics. In the U.S., levels of harmonics are usually described in terms of percentages of the fundamental (60-Hz) component. Thus, a waveform with over 100 percent of third harmonic is possible. This contrasts with the European convention of giving amplitudes as percentages of the root mean square (rms) voltage. Total harmonic distortion (THD) is obtained by squaring the amplitudes of each harmonic component (except the fundamental), summing the squares then taking the square root of the sum and dividing by the amplitude of the fundamental. Or, equivalently:

$$\text{THD} = \frac{\sqrt{\sum_{i=2}^{\infty} V_i^2}}{V_1} \quad [\text{Eq 5}]$$

(Again, the European convention is to normalize by dividing by the rms voltage, not the voltage of the fundamental.) Another measure of total harmonics is given by total demand distortion (TDD). TDD is defined by IEEE-519 as:

$$\text{THD} = \frac{\sqrt{\sum_{i=2}^{\infty} I_i^2}}{I_{\max}} \quad [\text{Eq 6}]$$

Another important consideration of harmonics for three-phase circuits is the concept of positive, negative, and zero sequence harmonics. If the currents in each phase at the fundamental frequency form a positive sequence, the second harmonic consists of negative sequence currents. This reversal of phase sequence leads in motors to torques that operate in the reverse direction, this decreases efficiency and leads to motor overheating. The third harmonic is then a zero sequence, and in this case, the currents in the

neutral line add together rather than cancel out. This pattern of positive, negative, and zero sequence is repeated for higher harmonics; the fourth harmonic is a positive sequence, the fifth negative, the sixth zero, the seventh positive, and so on.

Sources

In general, any nonlinear load is a source of current harmonics. A nonlinear load is one with an impedance that is not constant but is, instead a function of the applied voltage. These loads are generally characterized as "active" loads. ("Passive" loads include resistors, capacitors, and inductors.) For example, if a resistor is connected to an ac voltage, the current will be equal to V/R . Therefore, for a 60-Hz sine wave voltage source, the current will also be an undistorted 60-Hz sine wave. Likewise, while inductors or capacitors induce a phase shift between voltage and current, the current waveform is still a pure sine wave. In contrast, consider the circuit in Figure 2, which is a diode in series with a resistor. For a sinusoidal applied voltage, the corresponding current is shown in Figure 3. For half of the ac cycle, the diode is conducting and the current is simply given by V/R . For the other half of the cycle, the diode is not conducting and the current is zero. The resulting waveform is highly nonsinusoidal and contains large amounts of harmonics.

Nonlinear loads have nonsinusoidal current demands, and they are a source of current harmonics. Voltage harmonics are produced by the interaction of current harmonics and the rest of the distribution system. As the distorted currents flow through components of the distribution system, a voltage drop will occur across the components. This voltage drop will be distorted due to the current distortion. Therefore, other loads in the system will see a voltage waveform consisting of a 60-Hz sine wave with this voltage distortion added in.

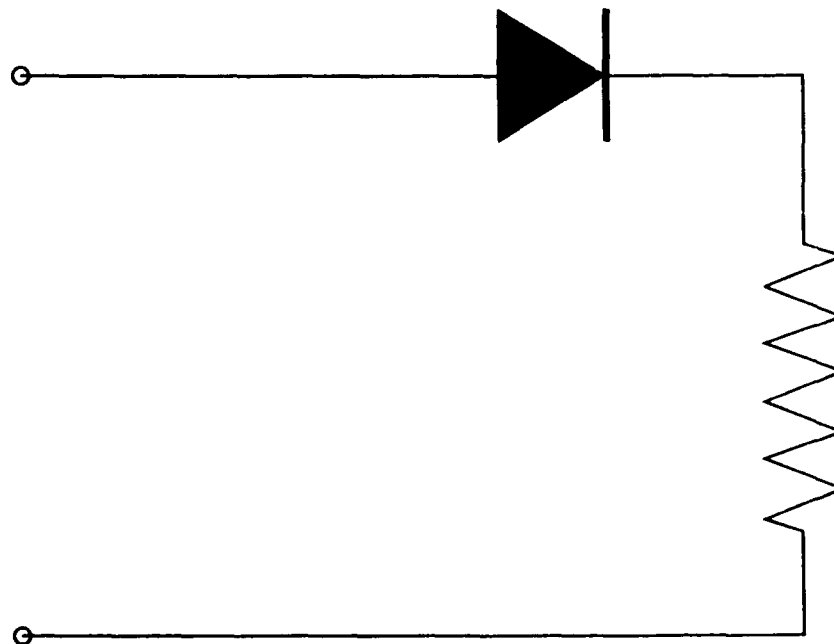

Figure 2. Simple Nonlinear Circuit.

In general, harmonic currents can damage elements of the distribution system. Although one load is not necessarily damaged because another load is a source of harmonic current distortion, if the currents are large enough and the impedance of the distribution system is high enough, harmonic voltages will be generated that can degrade loads elsewhere in the system.

An important source of harmonics are switching-mode power supplies (SMPSs), common in personal computers and many other types of electronic equipment. They function by rectifying the ac input into a dc voltage and using a large-value capacitor to filter this voltage. This voltage is then fed to a high-frequency dc-to-ac inverter and regulator. The resulting ac is then stepped down in voltage by the transformer and again rectified to produce the dc output. The harmonics are due to the behavior of the input rectifier and capacitor. As long as the voltage on the capacitor due to its own charge exceeds the ac input voltage, the power supply draws no current; this is the high impedance state. Near the peak of the ac input, when the input voltage exceeds the voltage on the dc bus, current flows through the rectifier, charging the capacitor; this is the low impedance state. Given the large value of the capacitor, this current can be quite high. The result is a current waveform that is zero except near the peak of the applied voltage, where the current rapidly rises to a large peak value and returns to zero. This current waveform is rich in third harmonics.

Harmonics are also caused by Uninterruptible Power Supplies (UPSs). Although they provide reasonably clean power to their loads, they produce harmonics on the line side. There are two basic types of solid-state UPS systems, the "off-line" type and the "on-line" type. The off-line type has a battery

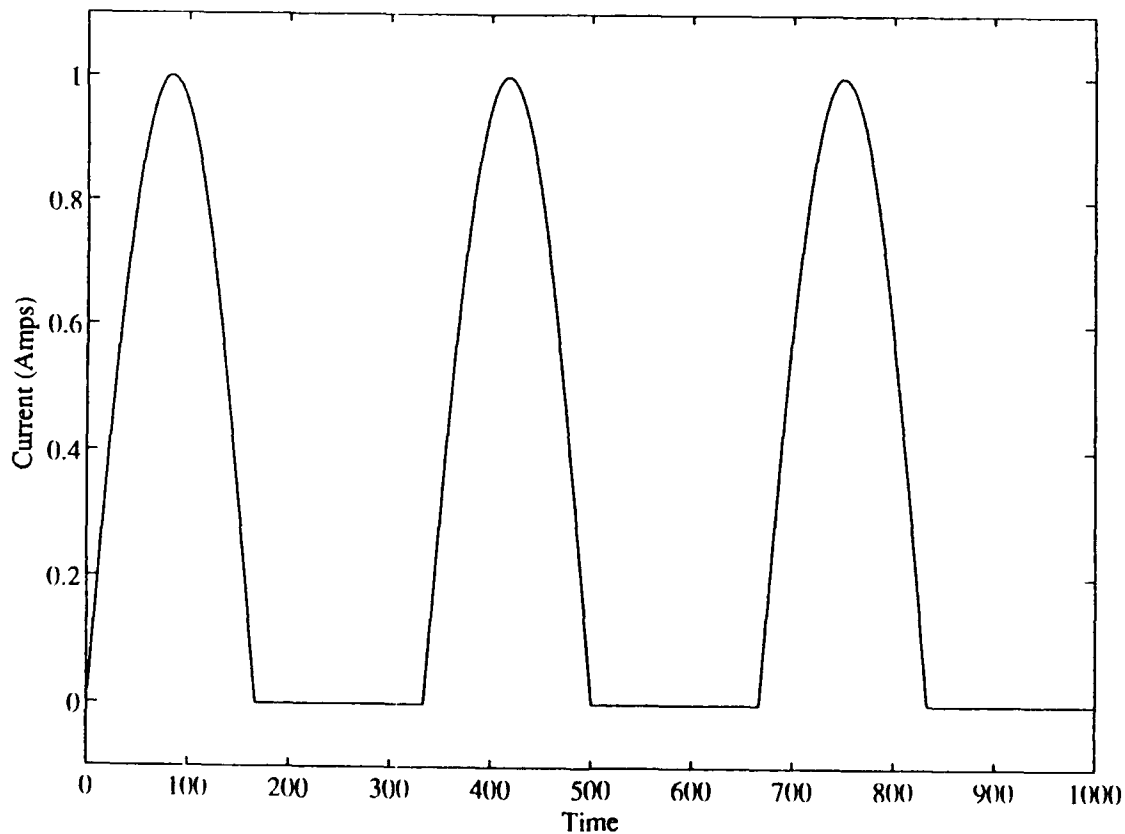

Figure 3. Current Flow in Simple Nonlinear Circuit.

charger, an inverter to generate ac from the dc (from the battery), and a circuit to detect power failure and switch in the battery powered inverter. This type of UPS generally has a short time between failure of the ac supply and activation of the battery backup, so it is not normally used in critical applications where even a very short outage cannot be tolerated. The off-line UPS is fairly clean in terms of harmonics generation, although harmonics from its load may still be present on the line side. The on-line type of UPS rectifies all ac input to dc and then inverts the dc back to ac, with a battery on the dc bus. If ac power is lost, the battery automatically maintains the dc bus voltage without any interruption of power to semiconductor devices and can generate a great deal of harmonics. As in the switching power supply, large current spikes occur when the rectifiers switch on.

Finally, adjustable-speed drives (ASDs) can be a major source of harmonics, particularly with the older models. Their principle of operation is similar to the UPS, with all the incoming ac rectified to dc and then inverted back to ac to run the motor. The harmonics are generated in the rectification stage. An added complexity is that the motor-speed control is frequently achieved by varying the phase angles of the input rectifiers. This produces a different waveform and different harmonic spectrum at different motor speeds. Another source of harmonics with some 3-phase ASDs is due to the finite switching times of the solid-state components in the rectification stage. The rectifiers are supposed to switch off when each phase component's voltage crosses the zero; however, the rectifiers actually remain on for a short time after the zero crossing. During this time, the ASD will appear as a short circuit across the phases, leading to extremely large current demands. These current spikes cause voltage notching on the distribution system. Spikes appear in the voltage profile at zero-crossing points for other phases and always lower the instantaneous voltage level.

Table 1 gives examples of current and voltage harmonics from real-world sources. The first example is a standard 4 lamp fluorescent light fixture with a high efficiency ballast. The harmonic content is not large, with mainly some third and fifth harmonics. Because the currents are so small, the voltage harmonics are due mainly to other sources on the distribution system; the voltage harmonics remain roughly constant regardless of whether the lamp is on. The second example is an IBM PC-AT personal computer. In this case, the SMP in the computer generates a great deal of third, fifth, and seventh harmonics. The voltage harmonics are identical to those measured on the fluorescent lamp. In the third case, a spectrum analysis is shown for one phase of an ABB Parajust 3-phase ASD.

Measurement and Instrumentation

Harmonics can be difficult to detect, particularly without proper equipment. One aspect of instrumentation and measurement that is often poorly understood concerns the differences between rms voltage (V_{rms}), average voltage (V_{avg}), peak voltage (V_{peak}), the form factor, and the crest factor. Peak voltage is the voltage at the peak of a waveform, or $170 V_{peak}$ for a $120 V_{rms}$ sine wave. Average voltage is the average of the absolute value of the voltage over one period, or $108 V_{avg}$ for a $120 V_{rms}$ sine wave. The root mean square (rms) voltage is obtained by squaring the waveform, averaging over one period, and taking the square root of the result.

Voltages for ac waveforms should always be specified in terms of the rms voltage. Relationships such as $V=IR$ (Ohm's law) and $P=IV$ (Watt's law) are only valid when the voltage and current are given in terms of their rms values. The crest factor is simply the ratio of V_{peak} to V_{rms} , and the form factor is the ratio of V_{rms} to V_{avg} . For pure sine waves, the crest factor is equal to the square root of 2 or 1.414, and the form factor is equal to 1.11. For nonsine waves, the crest factor and form factor depend on the exact shape of the waveform.

Table 1

Harmonics Measurements for Common Equipment

	Fluorescent Lamp		IBM PC-AT		ABB VSD	
	Volts	Amps	Volts	Amps	Volts	Amps
Total	120.0 V	1.28 A	120.0 V	2.00 A	282.6 V	11.51 A
Fundamental	118.9 V	1.28 A	120.0 V	1.41 A	282.2 V	6.66 A
2nd	0.25 %	0.77 %	0.25 %	0.71 %	0.04 %	1.05 %
3rd	3.36 %	6.15 %	3.33 %	82.27 %	0.14 %	7.65 %
4th	0.00 %	0.00 %	0.25 %	0.71 %	0.11 %	3.90 %
5th	2.35 %	6.15 %	2.33 %	53.19 %	1.45 %	84.26 %
6th	0.08 %	0.00 %	0.08 %	0.00 %	0.07 %	7.50 %
7th	1.26 %	0.00 %	1.50 %	29.79 %	0.96 %	80.81 %
8th	0.08 %	0.00 %	0.08 %	0.00 %	0.04 %	7.50 %
9th	0.42 %	2.31 %	0.42 %	9.22 %	0.14 %	12.14 %
10th	0.08 %	0.00 %	0.08 %	0.00 %	0.00 %	3.60 %
11th	0.34 %	0.00 %	0.33 %	2.13 %	0.50 %	47.83 %
12th	0.08 %	0.00 %	0.08 %	0.00 %	0.00 %	6.00 %
13th	0.34 %	0.00 %	0.33 %	4.96 %	0.32 %	46.18 %
14th	0.00 %	0.00 %	0.08 %	0.00 %	0.03 %	4.80 %
15th	0.00 %	0.00 %	0.33 %	3.55 %	0.07 %	9.30 %
16th	0.00 %	0.00 %	0.08 %	0.00 %	0.00 %	1.20 %
17th	0.00 %	0.00 %	0.25 %	2.13 %	0.43 %	19.34 %
18th	0.00 %	0.00 %	0.08 %	0.00 %	0.00 %	3.45
19th	0.08 %	0.00 %	0.08 %	1.42 %	0.18 %	16.94 %

These relationships between peak, average, and rms values are important for measurement. This is because meters that do not give true rms readings will give incorrect readings when harmonics are present. Most common meters are termed "average reading, rms calibrated." This means they physically measure the average value and scale it by an assumed form factor to display the rms value. Since the form factor depends on the shape of the waveform, a meter of this type will give incorrect results when used on a nonsinusoidal waveform, that is on one with harmonics present. For example, for a typical current waveform from an SMPS, the form factor is approximately 1.9. If an averaging meter reads 11.1 A_{rms} for this waveform (meaning it measured $10 A_{avg}$ and used a form factor of 1.11), the correct rms current is really 19 A_{rms} (1.9 times $10 A_{avg}$). For many distorted waveforms encountered in power systems, the averaging meter will yield too low a value for the voltage or current. Also, many meters lack the frequency bandwidth for proper measurements, even of I_{avg} . If the meter can only make accurate

measurements at 60 Hz or lower frequencies, it will tend to miss the contributions of the higher harmonics, causing further inaccuracies in measurement.

For these reasons, true rms meters are absolutely essential for measuring harmonics. However, even their utility is limited: they do not give any information about the shape of the wave or about its frequency spectrum. A harmonics analyzer, such as those made by BMI or Dranetz will give true rms measurements on voltage, current, and power. Such an analyzer will also give the total harmonic distortion (THD) and a spectrum analysis of the waveform. The disadvantages of a harmonics analyzer are its high cost (around \$15,000 vs \$300 for a true rms multimeter), its reliance on ac power, its complexity, and its size (about that of a small suitcase).

Effects

Probably the most widespread hazards due to harmonics are excessive currents and voltages in the neutral wire for 3-phase systems. Normally, in 3-phase systems, the loads are balanced and the phase currents sum to zero in the neutral. However, with harmonics present, the currents no longer sum to zero. In particular, for the third harmonic and multiples of it, the currents in the three phases are additive. In the worst case, even for balanced loads, the current in the neutral can be square root of three times the current in one of the phases. This is a worst case, but, it is not uncommon to find neutral currents greater than the phase current. This can cause significant I^2R losses in the neutral wire if it was designed for balanced loads and not to carry current. EHSC has documented cases where the neutral wire showed high current as a result of excessive harmonics.

Harmonics can also cause overheating in transformers and circuit breakers. Many of the losses in a transformer are frequency-dependent, and a transformer that is adequately sized to carry 100 Amps at 60 Hz may overheat and fail if a significant amount of harmonics are present. Magnetic circuit breakers can show similar effects. Evidence also shows that harmonics can cause nuisance tripping of breakers even when the currents are low—premature failure in power-factor correction capacitors, and inaccurate watt-hour meter registration. Harmonics can also cause failure of EMI/RFI filters which is the subject of this report.

3 EXPERIMENT

Overview

An experiment was performed using a heating/ventilation/air-conditioning test system with a 10-hp, 3-phase, 480-V induction motor driving a fan. This motor could be controlled by using an ASD, or a switch could be thrown enabling the ASD to be bypassed and allowing the motor to be operated with no control. The ASD is a rich source of harmonics (Figure 4). By monitoring the filter with and without the ASD operational, a determination could be made regarding the effects of harmonics on the filter.

Filter Selection

Although EMI/RFI filters are not standard in power systems, they can be purchased from several vendors, including ARK Electronics, Filtron, TCI, and Hopkins Engineering (manufacturer of the filters in Building 3100). These filters are designed to have a given attenuation characteristic over a certain range of frequencies. When the attenuation characteristic is known, the filter is chosen according to the required load current. Most filters are rated for line-to-line applications of up to 480 V. The term "insertion loss" characterizes the efficacy of these filters. As defined in the relevant standard (MIL-STD-220A), "the insertion loss of a feed-through suppression capacitor or a filter connected into a given

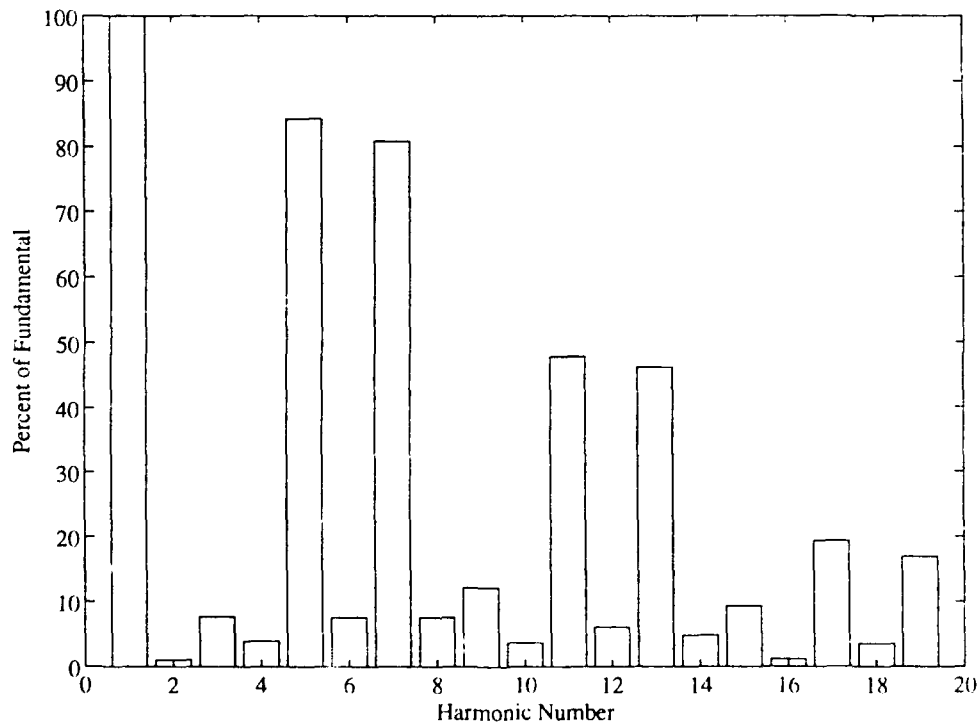

Figure 4. Current Harmonics From ASD.

transmission system is defined as the ratio of voltages appearing across the line immediately beyond the point of insertion, before and after insertion." This is usually expressed in decibels (dB). Filter specifications generally include a plot of insertion loss over a range of test frequencies. MIL-STD-220A describes a test procedure that should be applied to determine the insertion loss achieved by a specific filter. Filters used in military installations are tested according to the provisions of this specification.

A foreword to MIL-STD-220A issues a caveat with regard to this standard. The test conditions described therein specify filter performance connected to a source with a 50-ohm input impedance and a 50-ohm output impedance. The source and load impedances seen by power system filters will not be the same in different locations, and 50 ohms cannot be considered a typical value. It is certainly possible to design a filter that will meet specifications when tested according to this standard, however when applied in an actual power system, the desired characteristics will not be achieved.

Preliminary theoretical modeling of EMI/RFI filters under harmonic loading conditions suggested that different filters might show widely different responses to harmonics. The filters used for EMI/RFI filtering are quite simple in design, but the very nature of their design causes problems when harmonics are present. According to MIL-STD-220A, EMI/RFI power-line filters must have at least 100 dB of attenuation (with a 50-ohm load) for frequencies exceeding 14 kHz. Most manufacturers will guarantee 100 dB of attenuation for frequencies greater than 14 kHz. However, for frequencies in between 60 Hz and 14 kHz, no measure of attenuation is asserted. Since this region contains most of the harmonic disturbances in a system, attenuation in this spectrum should be addressed. Also, standards are needed to ensure that attenuation in this region is maintained.

The EMI/RFI filters are of the lowpass filter design and are made primarily of passive components. These capacitors and inductors tend to be large to meet ratings requirements. When a designer chooses to use such components, the parasitic elements (lossy or resistive elements associated with the components) are not normally taken into consideration. This is because their behavior at 60 Hz is not a significant factor and can be ignored. However, in the harmonic frequency range of 180 Hz to 3 kHz, these parasitics play a potentially substantial role in power losses in the filter. This is one reason they are necessary for a realistic model. Further, at high frequencies these parasitic elements dominate the behavior of the filter.

Experiments were performed on two brands of filters. The first filter tested was part number ARK30, manufactured by ARK Electronics Corporation. This filter's schematic diagram is shown in Figure 5. This filter provides 100 dB of attenuation from 14 kHz to 10 GHz, and it is rated at 30 Amps, 277-Vac line-to-neutral, and 480-Vac line-to-line. Three identical filters were purchased and mounted in a common enclosure to provide 3-phase filtering capability. The other filter tested was a FSRY10B3 Filtron filter. This filter provides 100 dB of attenuation from 14 kHz to 10 GHz, and it is rated 10 Amps, 0-277-Vac line-to-neutral, and 480-Vac line-to-line. This filter is a 3-phase filter, but it is simply a cabinet containing single-phase filters. The schematic for one of the single-phase filters is shown in Figure 6.

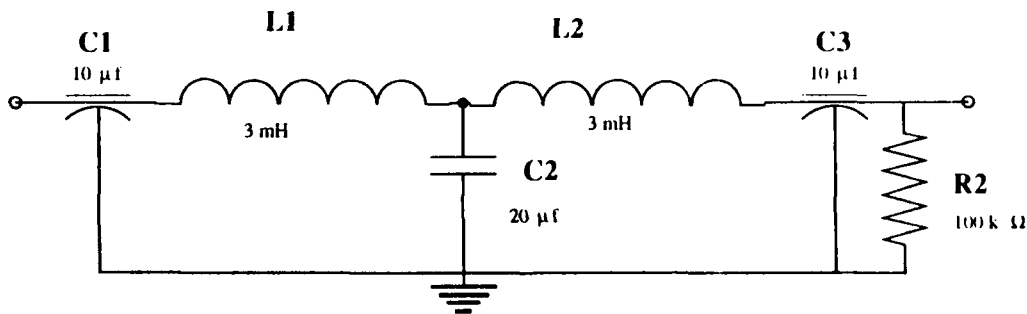

Figure 5. Schematic of ARK Filter.

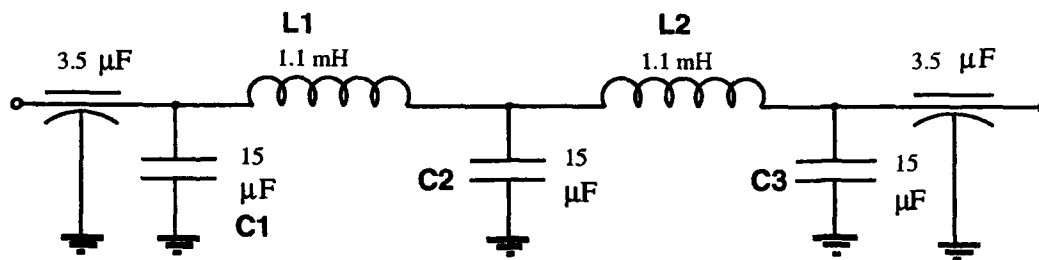

Figure 6. Schematic of Filtron Filter.

Experimental Apparatus

The experimental apparatus is shown in Figure 7. The filters were connected to a 480-Vac supply through a safety switch on one side, and to either a motor starter or ASD on the other. A class 3140 safety switch connected either the motor starter or the ASD to the 10-hp induction motor.

The ASD was a Parajust Gx, manufactured by ASEA Brown Boveri in 1989. It is rated 460 Vac, 60 Hz, 14.6 amp, 3-phase, and provides an output of 0-460 Vac, 0-180 Hz, 3 phase, at a maximum of 17 Amps continuous. The motor starter was a NEMA size 1 starter with B22 thermal overloads. The motor is a Gould/Century unit rated at 10 hp, 460 Vac, 13.5 Amps, and 3 phase at 1750 RPM.

The data acquisition system is shown in Figure 8. The Filtron filter was instrumented with three type T thermocouples, model TMTSS-125G from Omega Engineering. The thermocouples were attached directly to components C1, C2, and L1 (Figure 6). These thermocouples are rated at 425 °F. An additional type T thermocouple, model SA1-T from Omega Engineering, rated at 500 °F measures the temperature of the filter's case. Data acquisition and logging were performed using an IBM PC/AT computer using an 80286 microprocessor and an 80287 math coprocessor running at 8 MHz. The computer contains a Keithly Metrabyte DAS-16F high-speed, programmable, analog-to-digital converting board. The board uses a 12-bit, successive-approximation converter with an 8.5 microsecond conversion time to achieve throughput rates in the 100 kHz range using DMA.

An MB-01 backplane, which accommodates signal conditioning modules, was connected to the DAS-16F with a ribbon cable. Two MB40 signal-conditioning modules monitored currents on two of the three phases. These had an input range of +/-100 mV, an accuracy of +/-0.05 percent full scale, a nonlinearity of +/-0.02 percent full scale, and a bandwidth of 10 kHz. Also connected to the MB-01 backplane were two MB41 voltage input modules with an input range of +/-10 V, an accuracy of +/- 0.05 percent full scale, a nonlinearity of +/-0.02 percent full scale, and a bandwidth of 10 kHz. These modules monitored the line-to-line voltage and the voltage drop across one of the filters. Four MB47 linearized type T thermocouple input modules were also present on the backplane. These modules had a +/-0.05 percent full scale accuracy and a bandwidth of 4Hz. The data acquisition and logging software was Labtech's Notebook software version 6.1.2. This software performs high-speed data acquisition, data logging, and FFTs. The software analyzed the temperature of the various filter components and the harmonic content of the filters' inputs.

A Basic Measuring Instruments (BMI) 3030A Power Profiler was used to measure harmonic currents very accurately in each phase by using a current probe attached to that phase and automatically printing out the results. This confirmed the accuracy of the PC-based data acquisition system.

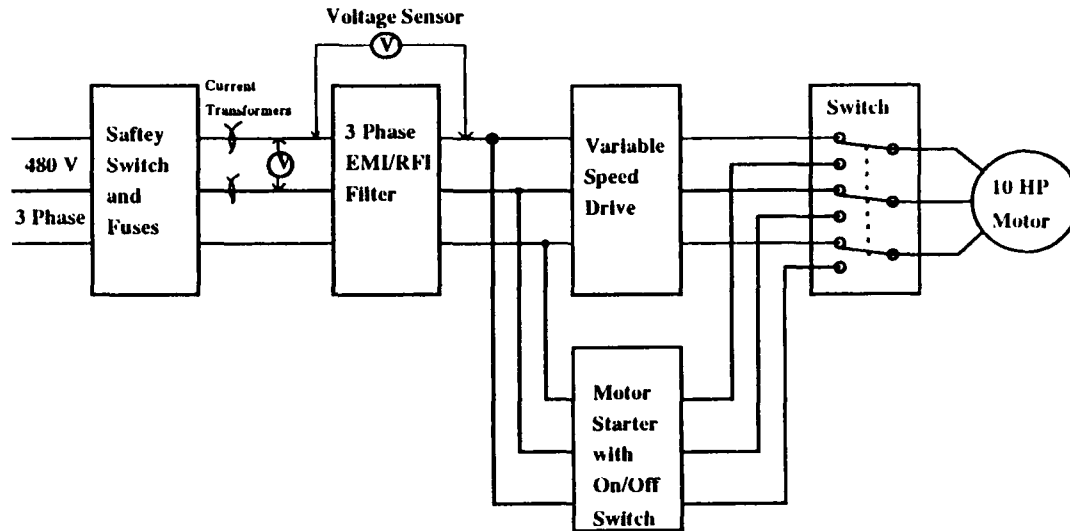

Figure 7. Experimental Apparatus.

Temperature Results

The first filters instrumented were the ARK filters. The temperature rise was found to be only about 4 °F in the inductor after several hours with the ASD, and even less in the other components. The temperature rise without the drive was approximately 3 °F over the same period. Because the filter was not mounted in a temperature-controlled environment, the 1 °F difference was not significant, and no further testing or simulations were performed. Fairly crude modeling and power-loss measurements showed no significant difference between the two cases.

The temperature results for the Filtron filters are shown in Figures 9a and 9b. Although the temperature rise was not large in either case, the cases differed significantly depending on whether harmonics are present. Particularly noteworthy was the temperature rise in the inductor in the filter, which agrees with the measured power-loss values and with the simulation results.

Waveform and Power-Loss Results for Filtron Filter

The line-to-line voltage waveform with the ASD engaged is shown in Figure 10a, and the frequency spectrum is shown in Figure 10b. The waveform with and without the ASD are almost identical. It is clear that there is negligible voltage distortion on the line due to the ASD. This is due to the relatively high short-circuit current rating of the distribution system compared to the ASD's current demands.

The current through the filter without the ASD is shown in Figure 11a, and the corresponding harmonics spectrum is shown in Figure 11b. Although the waveform appears significantly distorted, the amount of harmonics present is quite low, with the largest single component being the 17th harmonic, with a magnitude of 0.25 percent of the fundamental. This confirms the assumption that, without the ASD, the filter sees a linear load, namely the 10-hp induction motor. Figures 12a and 12b show the voltage drop across the filter for the same conditions. The waveform appears considerably richer in harmonic content. The frequency spectrum shows considerably more harmonics, with significant harmonic content in the 3rd, 5th, 13th, 15th, and 17th harmonics. This indicates significant voltage drop at frequencies other than 60 Hz. The power dissipation spectrum in the filter without the ASD is shown in Figure 13. The corresponding time-domain plot is omitted because of the large number of high-frequency components

makes visual interpretation impossible. The measured average power dissipation for this case was 21.4 Watts.

The corresponding plots for the filter with the ASD in the system are shown in Figures 14a, 14b, 15, and 16. Figure 14b shows the large amount of 5th, 7th, 11th, 15th, and 17th harmonics present in the current. In Figure 15 (the voltage spectrum across the filter with the ASD), the magnitude of the harmonic components relative to the fundamental is so large that the y-axis has been scaled relative to the largest harmonic component, the 12th harmonic. This is in contrast with the other spectrum plots, where component magnitudes have been shown as a percentage of the fundamental. Finally, the filter-power spectrum with the ASD is shown in Figure 16. Again, the component magnitudes are scaled relative to the largest component, rather than to the fundamental. The measured average power dissipation for this case was 45.4 Watts, or 212.2 percent larger than the dissipation for the control case without the ASD in the system. This number can be considered a typical upper limit for filter overheating due to harmonics.

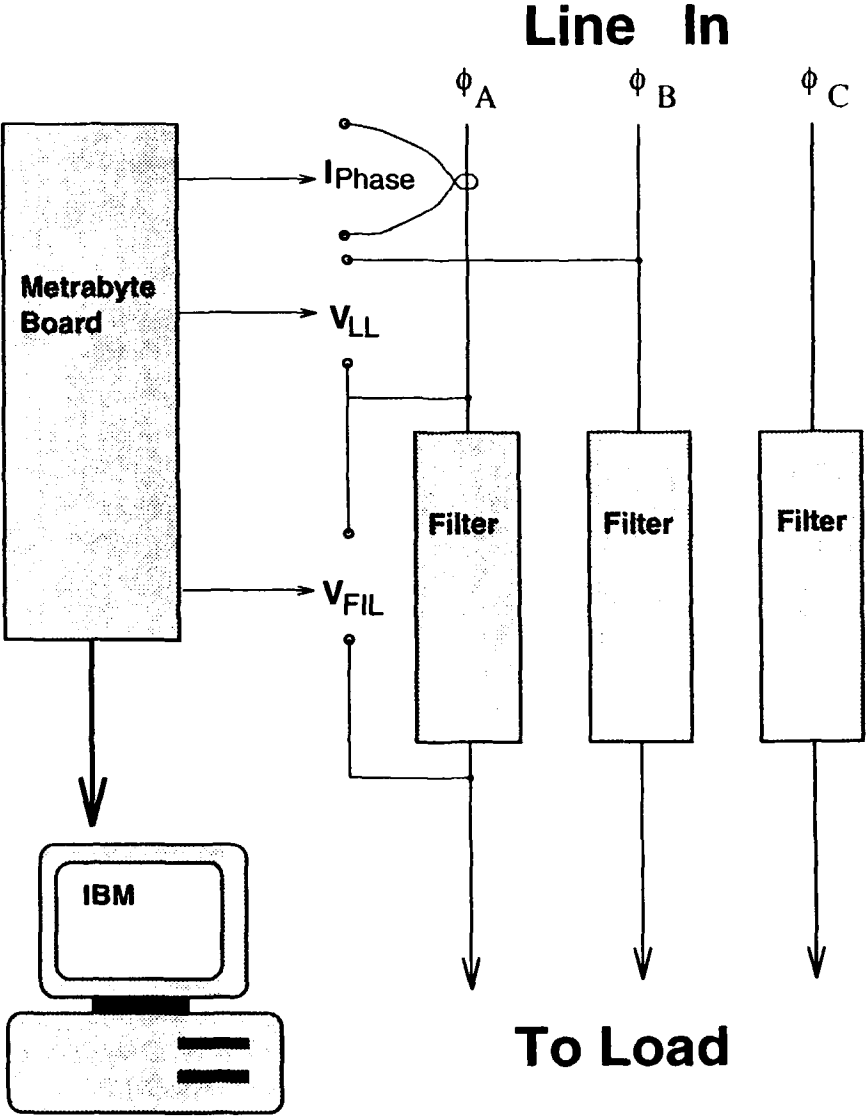

Figure 8. Data Acquisition System.

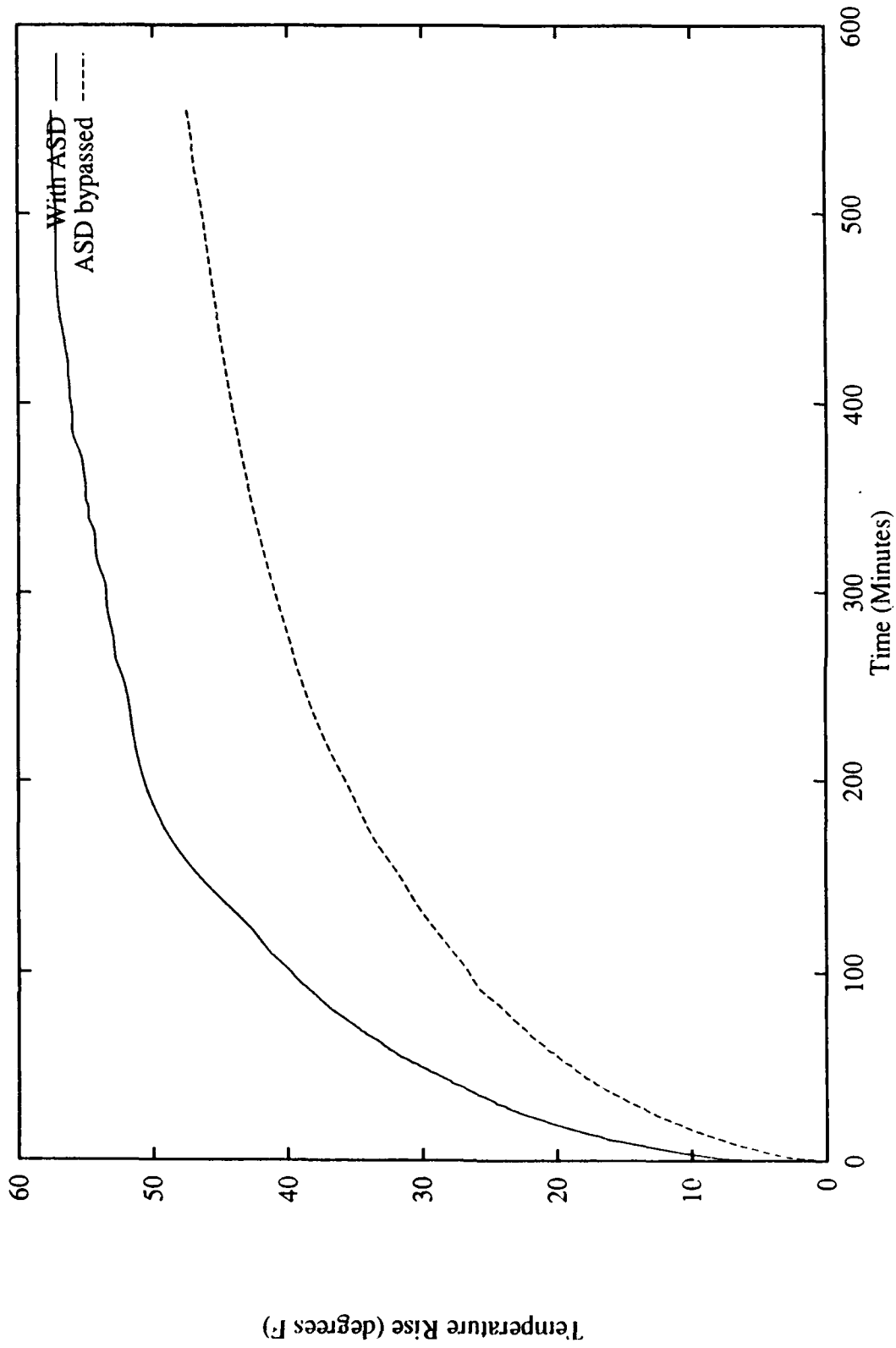

Figure 9a. Temperature Rise in Inductor.

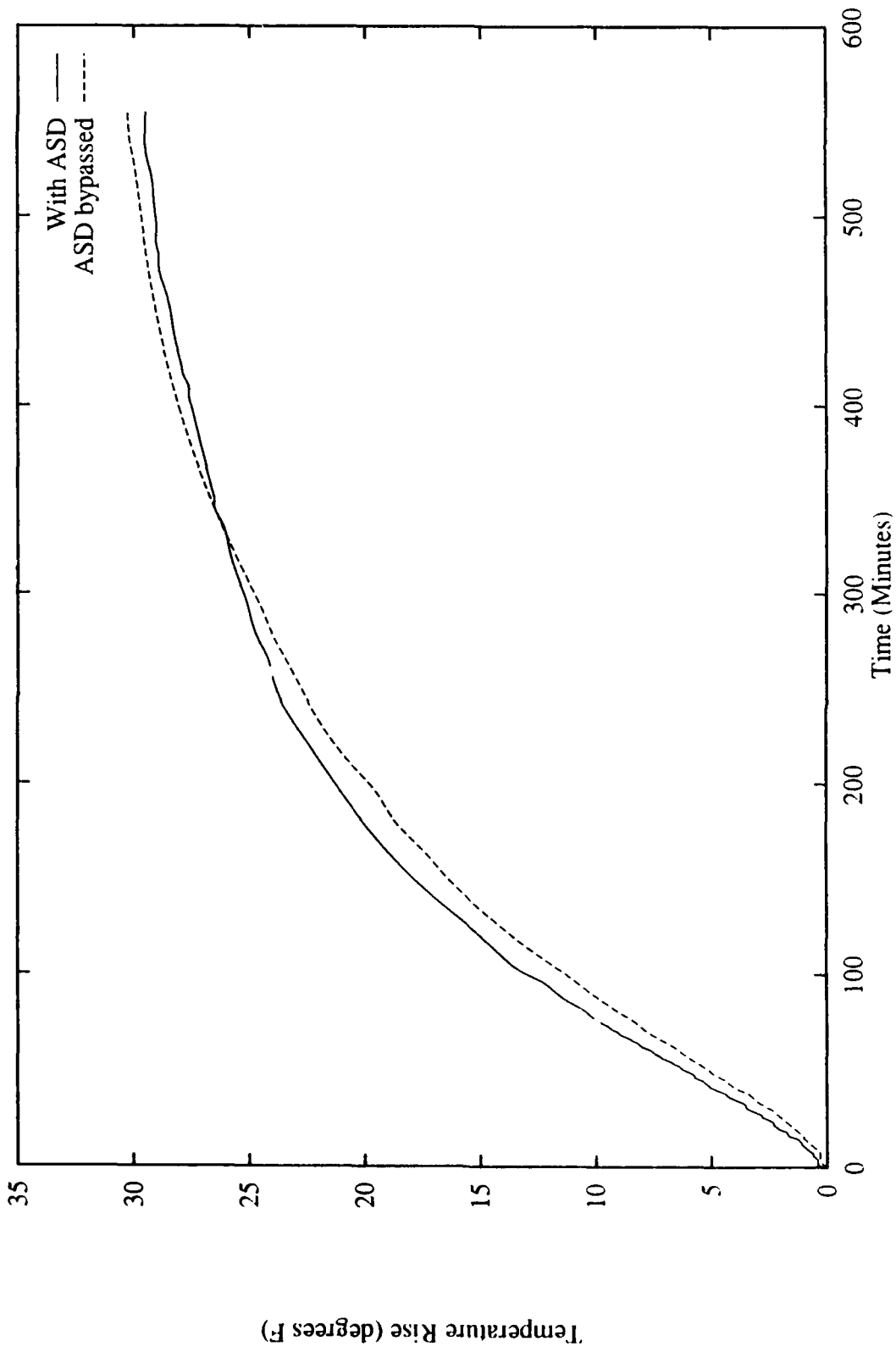

Figure 9b. Temperature Rise in C1.

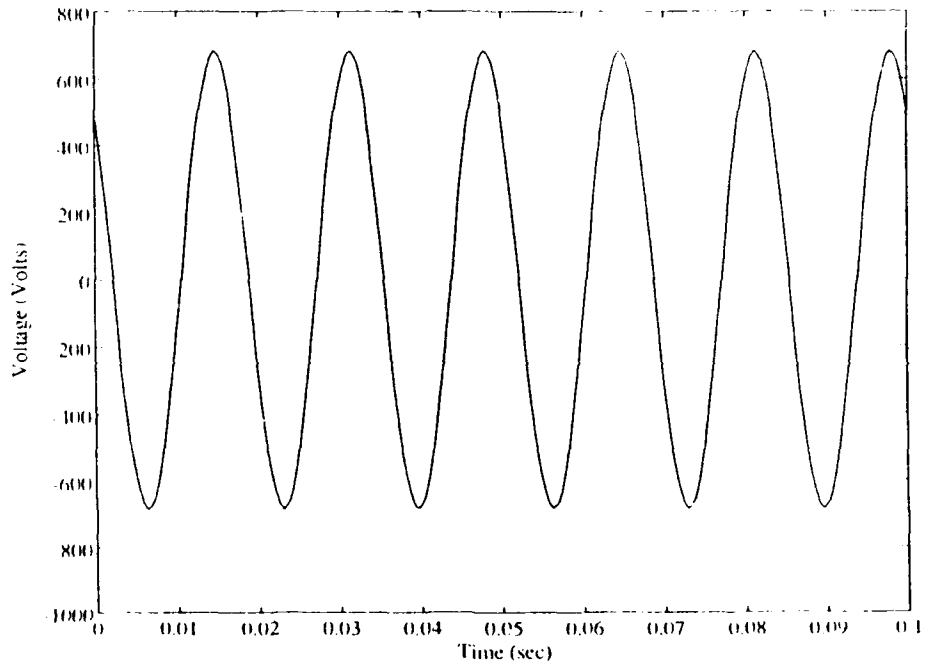

Figure 10a. Line-to-Line Voltage With ASD.

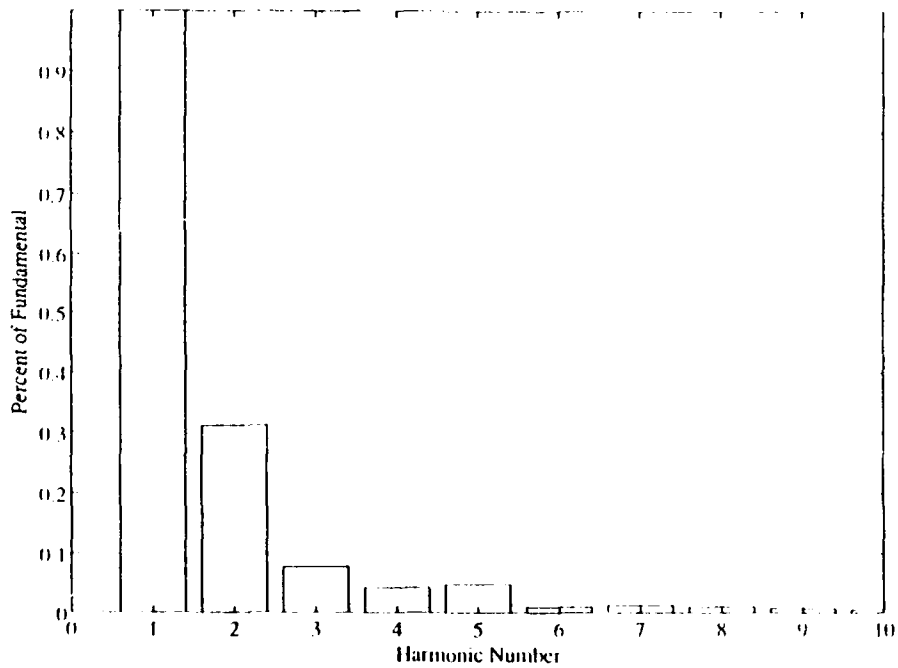

Figure 10b. Line-to-Line Voltage Spectrum With ASD.

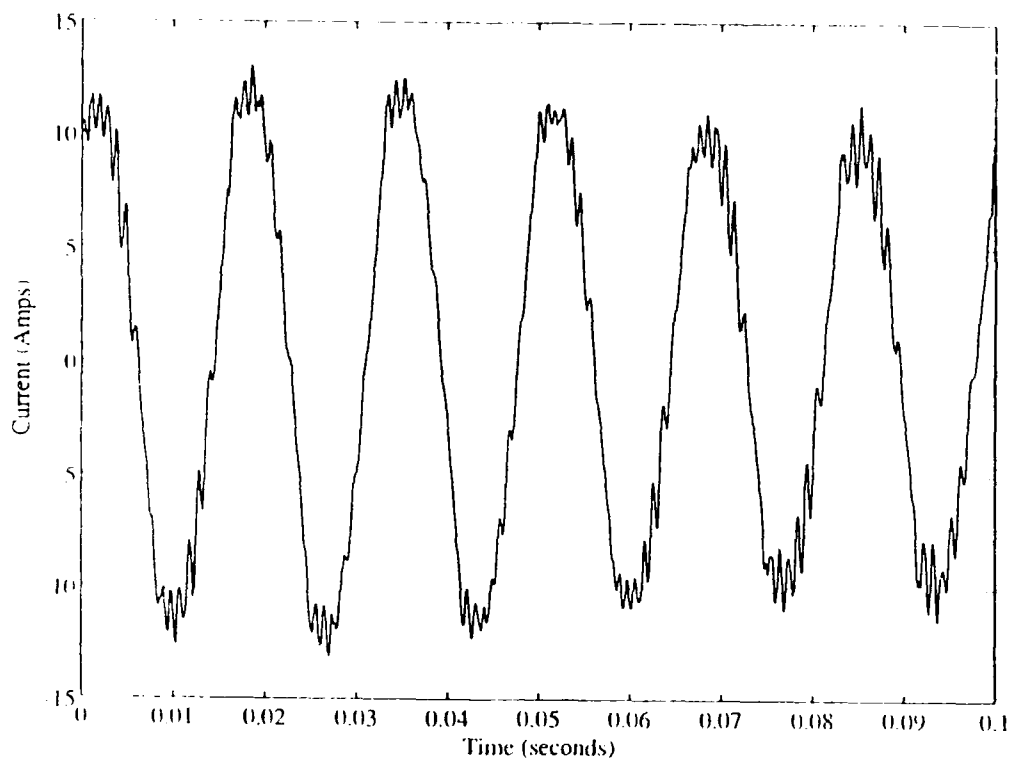

Figure 11a. Filter Current Without ASD.

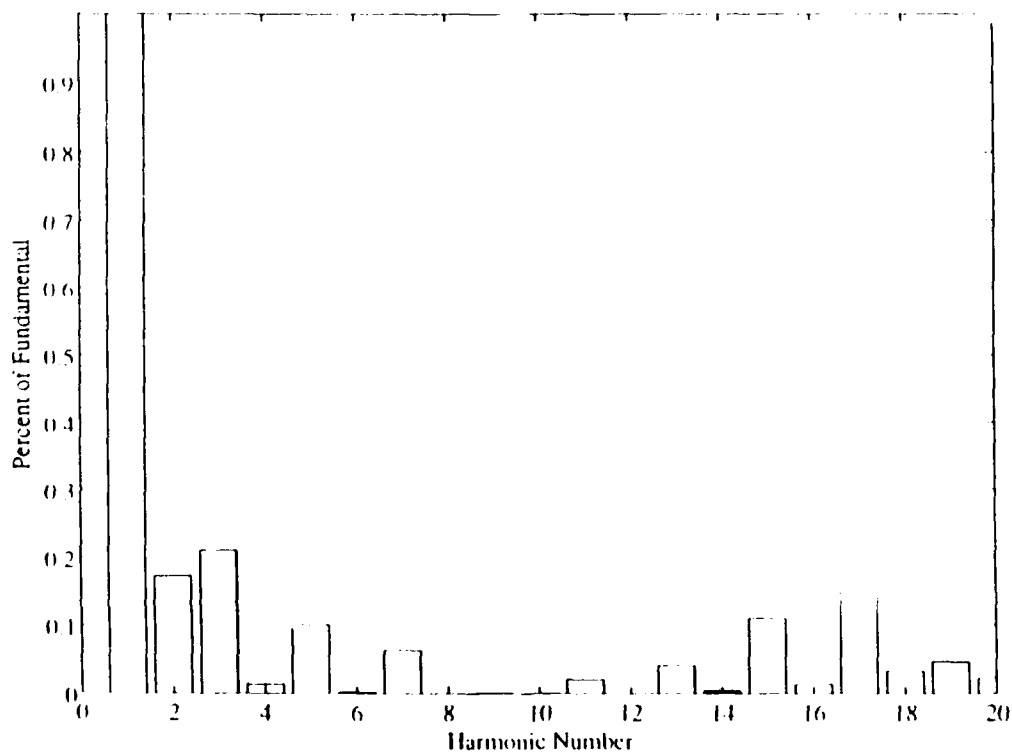

Figure 11b. Filter Current Spectrum Without ASD.

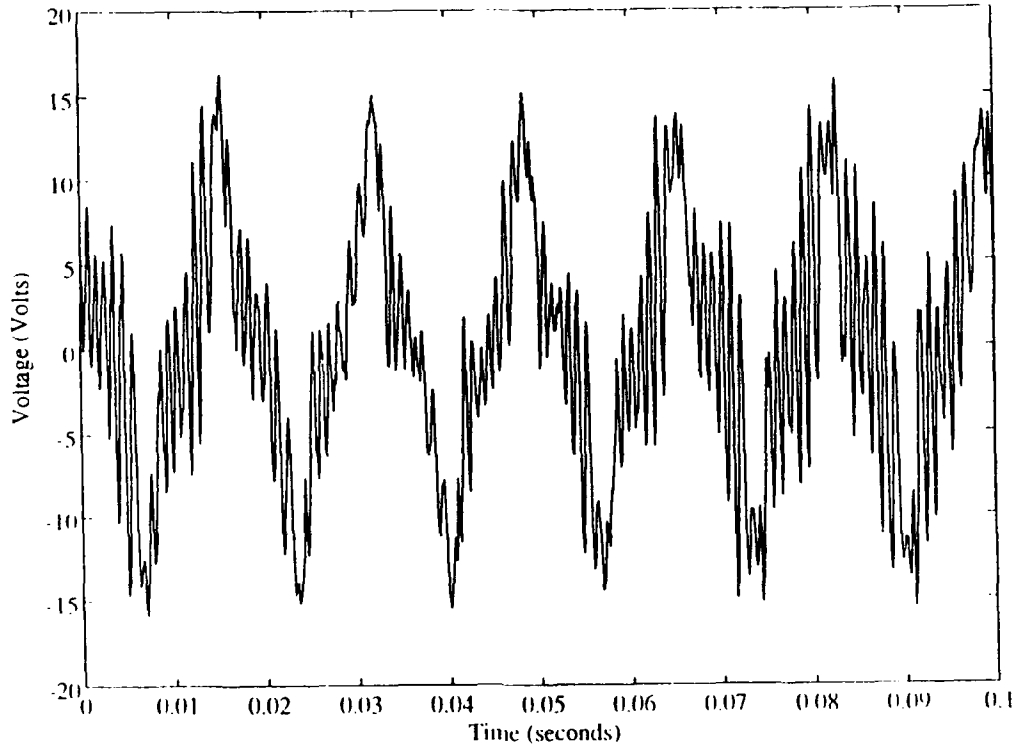

Figure 12a. Filter Voltage Without ASD.

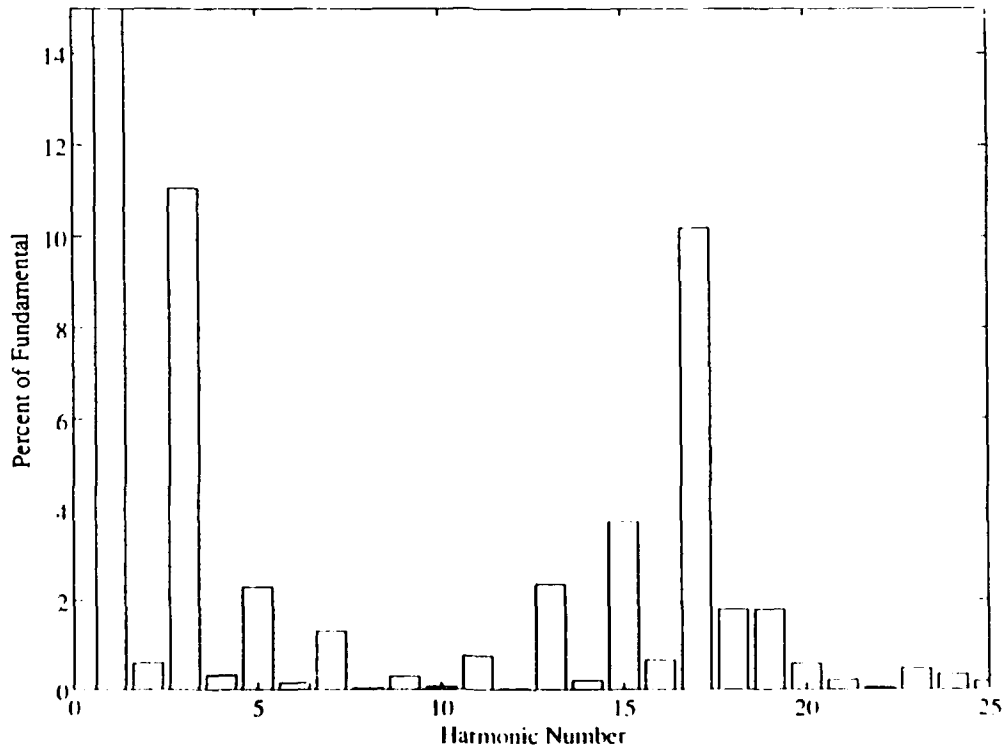

Figure 12b. Filter Voltage Spectrum Without ASD.

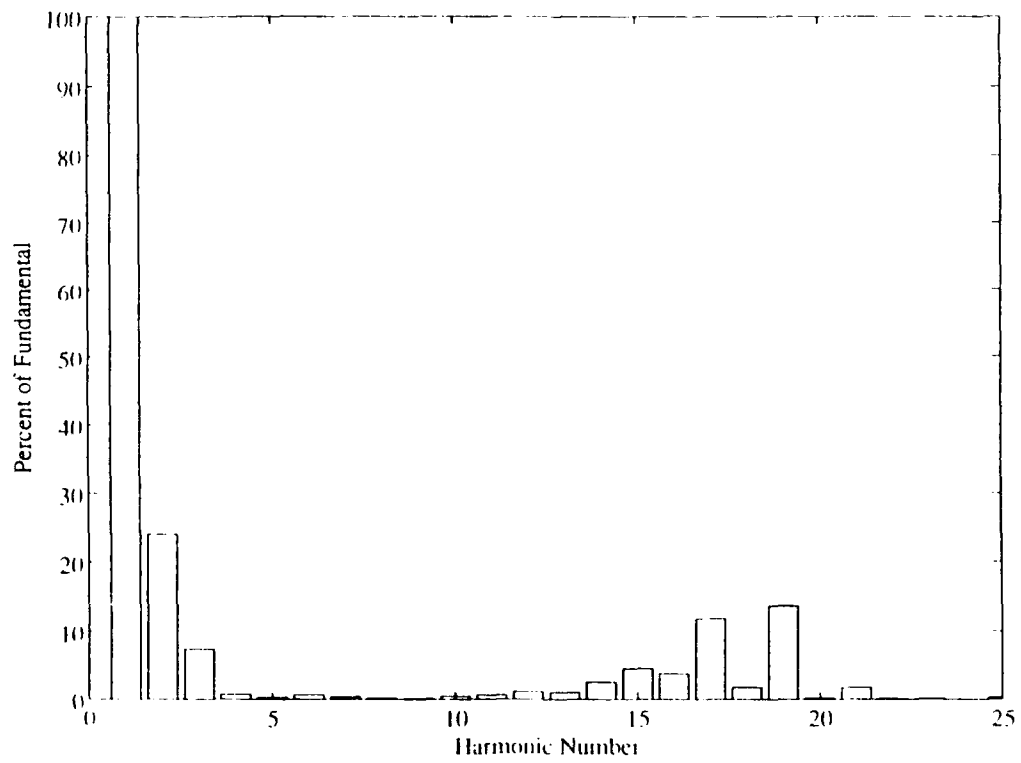

Figure 13. Filter Power Spectrum Without ASD.

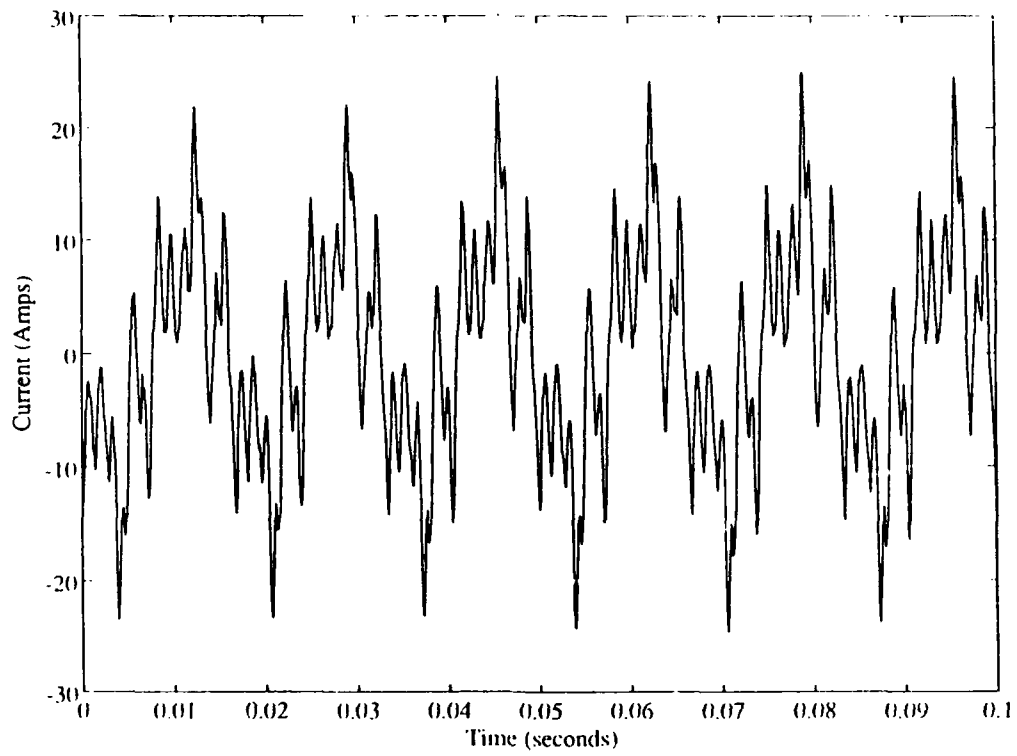

Figure 14a. Filter Current With ASD.

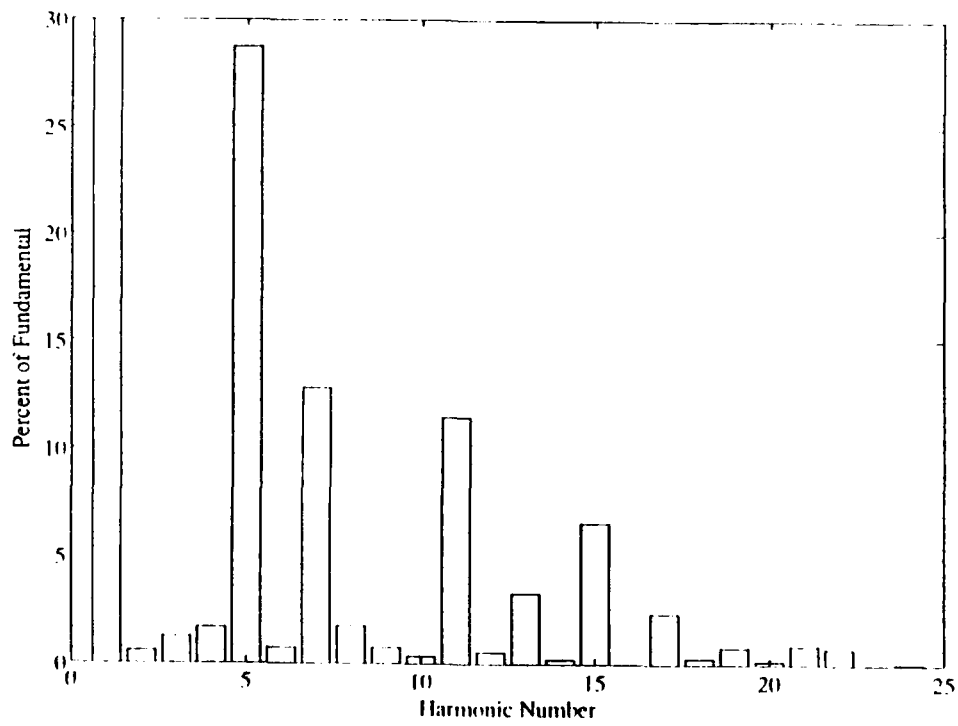

Figure 14b. Filter Current Spectrum With ASD.

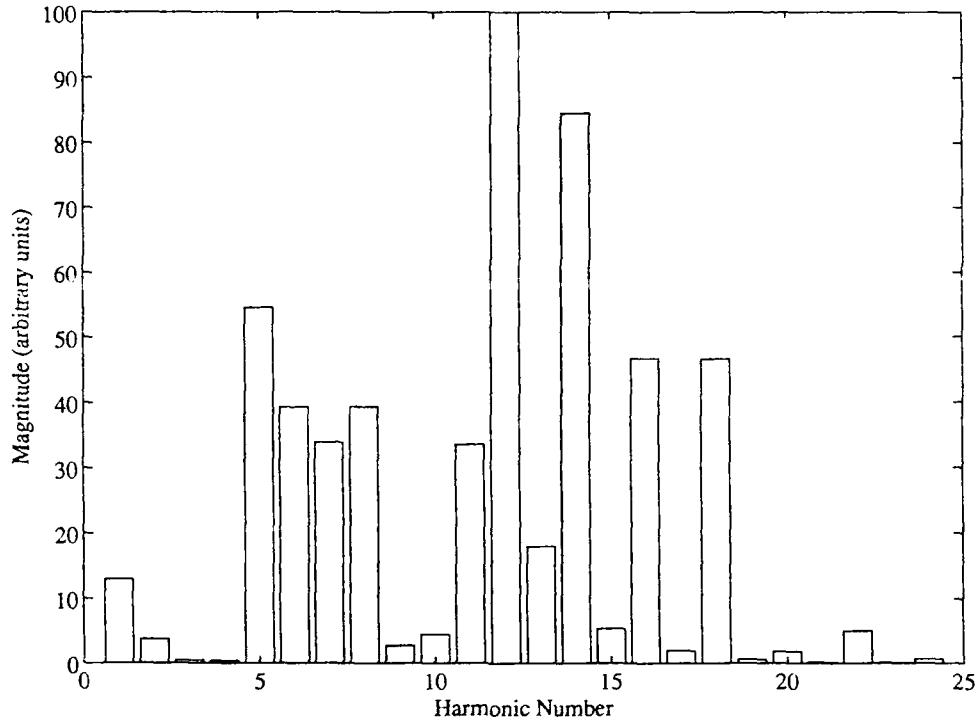

Figure 15. Filter Voltage Spectrum With ASD.

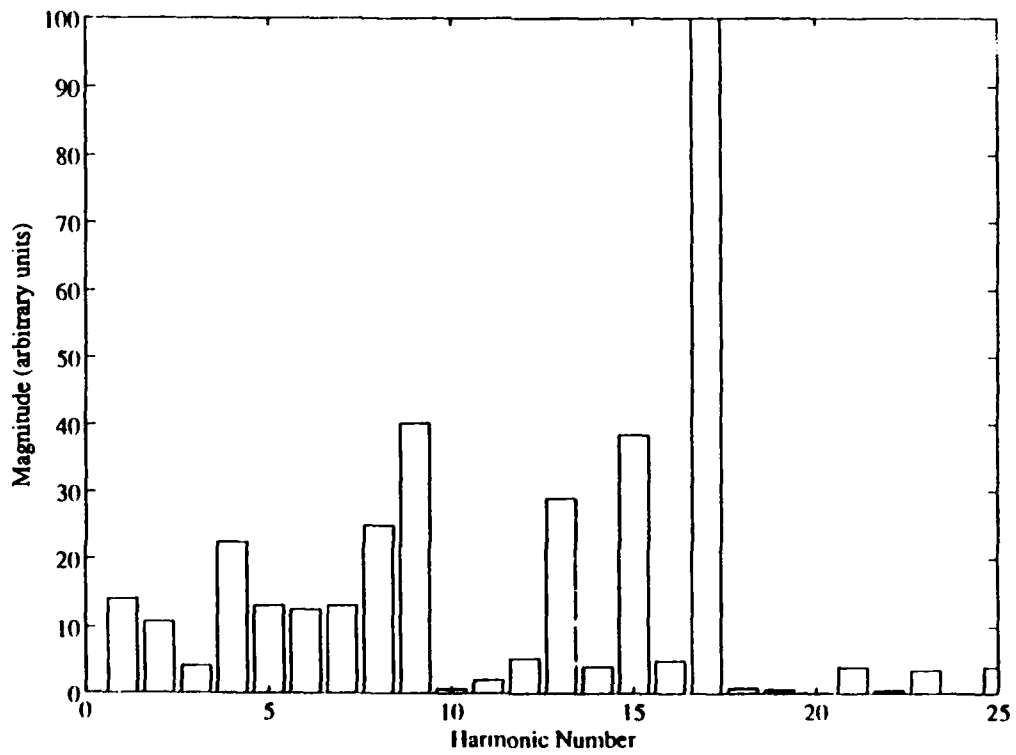

Figure 16. Filter Power Spectrum With ASD.

4 THEORY

Overview

Heydt (1987) and Subjak and McQuilken (1990) discuss overheating in equipment due to harmonics, but the nature of these losses has not been properly addressed. Through proper modeling and simulation, it can be determined whether harmonics in the frequency range not specified by the filter manufacturers ($60 \text{ Hz} < f < 14 \text{ kHz}$) interact with parasitics in the filter, leading to extreme power losses and proportional increases in heat as harmonic content increases.

The modeling of equipment or components can be severely altered in the presence of harmonics. Models that represent equipment at 60 Hz can be radically different at harmonic frequencies. For instance, the additional parasitics become important and must be included at increasing frequencies. Inductors and capacitors can have as few as three parasitics associated with them in the harmonic frequency spectrum, and they can have radically different parasitics at even higher frequencies. In addition, nonlinear magnetic effects such as those seen in inductors and transformers must be modeled specially. This is typically due to core properties such as hysteresis. Also, to determine harmonic effects, nonsinusoidal currents need to be formulated.

The circuit diagrams obtained from ARK and Filtron for their filters are shown in Figures 5 and 6. The diagrams show only passive components (inductors and capacitors). Computer simulations were performed on these model to determine the filters' attenuation characteristics at various frequencies. The results of these simulations are shown in Figures 17a and 17b. The filters attenuated signals very well toward the upper end of the frequency range; however, at frequencies between 60 Hz and 1500 Hz little attenuation was achieved. There is even a range that suggests amplification of these signals. In addition, even though both filters met MIL-STD-220A, they responded very differently in the range of harmonic frequencies. This suggests that their susceptibility to overheating due to harmonics will vary widely, as born out by experiment.

A test was performed under conditions similar to those of MIL-STD-220A to determine the Filtron filter's actual frequency response. A 50-ohm load was the simulated load, and a variable-frequency power supply was the source. The measured response for the Filtron filter is shown in Figure 18. Although this response curve is much flatter than the ideal curve (note the reduced scale on the y-axis), it still shows some gain at harmonic frequencies. This indicates that even a small harmonic presence in this region could lead to significant power loss.

The crucial difficulty with the schematic provided by the manufacturer is that the simulation based on this schematic suggests zero real power loss across the filter due to the lack of dissipative components. (The bleeder resistor in the ARK filter has negligible power loss). Thus, a model of the filter that accounts for parasitic elements and power loss is needed to determine which elements cause power loss and where possible resonances exist. For these reasons, a significant amount of testing was necessary to gather information not available from the manufacturer. Since MIL-STD-220A does not specify filter response in the crucial range of 180 Hz to 3 kHz, this information may not even be known by the manufacturer. Once a reasonable model of the filter was constructed, including parasitic elements, simulations could determine power loss in the filters.

Construction of Filter Model

A model of the filter circuitry was determined in the laboratory by modeling both the inductors and capacitors as individual elements. The feed-through capacitors at either end of the filter were modeled as simple capacitors because their resistances are very low and cannot be accurately measured. As will be seen, power loss across capacitors was not a significant factor in the overall power-loss picture.

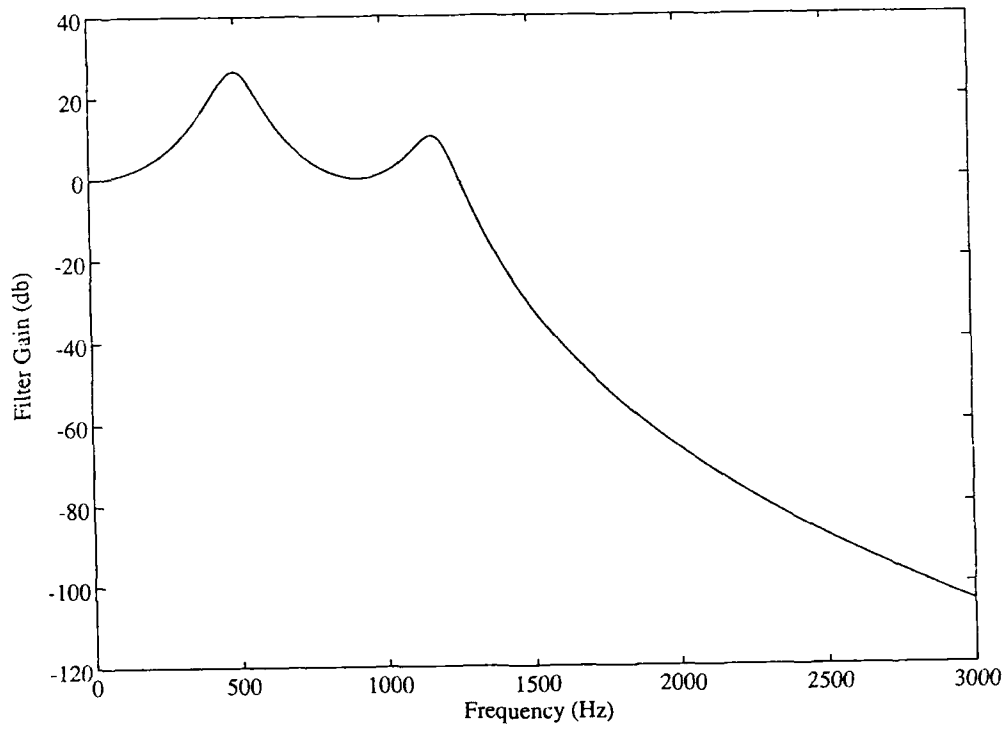

Figure 17a. Ideal ARK Frequency Response.

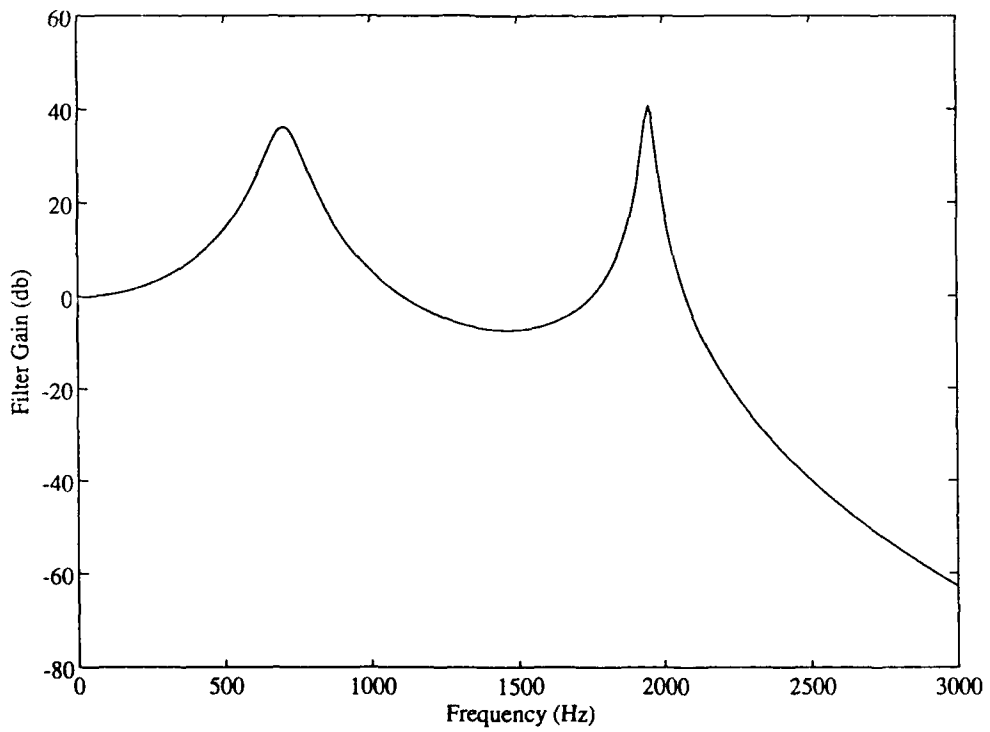

Figure 17b. Ideal Filtron Frequency Response.

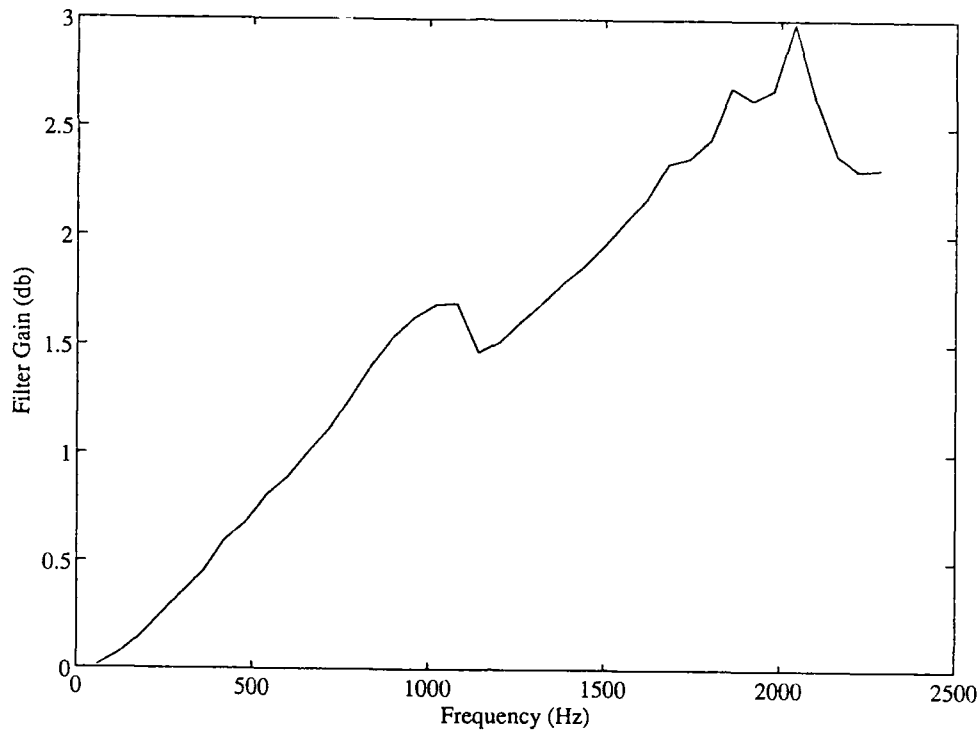

Figure 18. Measured Filtron Frequency Response.

Filtron stated a capacitance of 15 μF for three of the capacitors (see Figure 6). An experiment was performed to test the response of one of these capacitors in the presence of higher frequencies. The model shown in Figure 19 was constructed based on this response, using the output from a Hewlett-Packard network-analyzer test as the framework. Parasitic elements dominate the modeling of the capacitor for this application. This is due to the magnitude of the higher frequencies under testing and simulation.

The formula for voltage drop across an inductor is given by:

$$V_L = \frac{\lambda}{I} \frac{di}{dt} \quad [\text{Eq 7}]$$

where $\frac{\lambda}{I}$ is the slope of the hysteresis loop, the $\frac{di}{dt}$ is the change in the current per-unit time and is time rate of change of the current. A hysteresis test across the inductor was performed with the setup shown in Figure 20. Once the hysteresis loop was determined, a method to model this loop was needed. Wong (1988) suggests breaking the loop into segments and using the exponential function to represent the individual segments in the hysteresis loop. The slope can then be determined. Note that since the inductance depends on the hysteresis loop, it is not constant. Calculated values $\frac{\lambda}{I}$ for which corresponds to the inductance, range from 0.05 mH to the stated value of 1.2 mH. A dc test was also performed on the inductors, yielding a value of 0.14 ohms as their dc resistance. A value of 4.3 μF capacitance was determined after simulating the resonance point, which was determined by sweeping the inductor through frequencies and measuring voltage and current. The final model for the inductor is shown in Figure 21. Note that the hysteresis loop was used only for calculating the inductance; actual hysteresis losses were not taken into account. The nonlinear nature of the loop and the complexity of the current waveform through the filter under harmonic loads make calculation of hysteresis losses difficult.

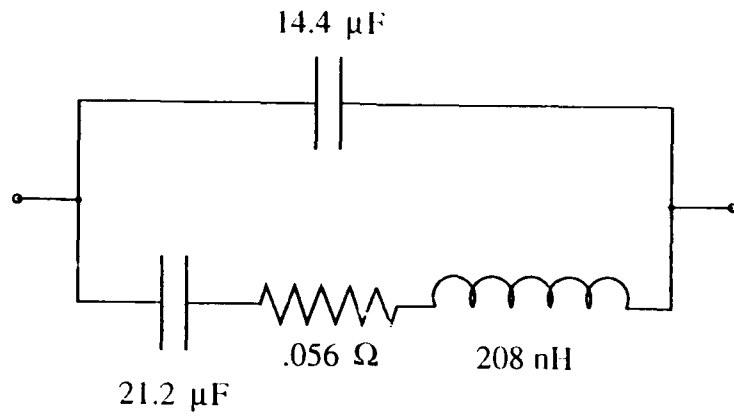

Figure 19. Final Model of Filtron Capacitor.

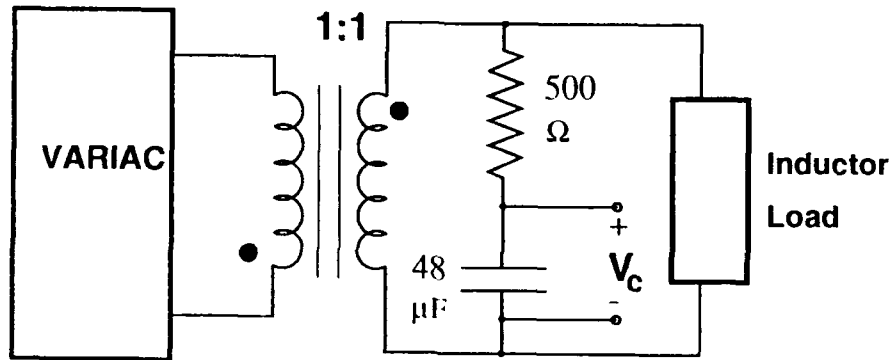

Figure 20. Inductor Test Apparatus.

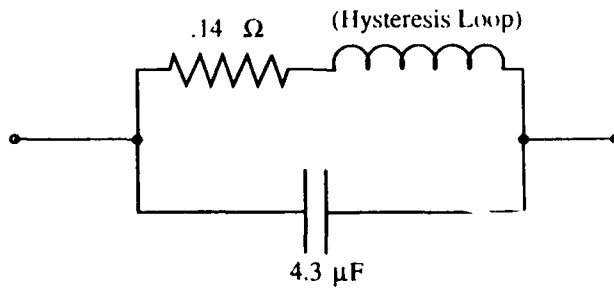

Figure 21. Final Model of Filtron Inductor.

The overall filter model is shown in Figure 22. It is still symmetrical in nature, but with parasitics added it looks very different from the original circuit model.

Simulation Results

A simulation of the attenuation characteristics of this model is shown in Figure 23. This response shows characteristics similar both to the ideal model and to the measured characteristics. Again, there is significant gain in the harmonic frequency range. The model is valid only below about 3 kHz, the limit on the inductor model.

The next simulation performed on the final Filtron filter model was to determine power loss for various frequencies. One amp of current was injected into the filter model at harmonic frequencies, and simulated average power losses over one period were calculated. The results of this simulation are shown in Figure 24. It is clear that large harmonic currents at the 13th or 15th harmonic result in large power losses in the filter—much larger than those that result from the same currents at 60 Hz. In fact, 1 amp at the 15th harmonic will cause as much power loss as 60 Amps at 60 Hz. Although the losses are even greater at the 14th harmonic, significant current in a real system at such a high-order, even harmonic is rare.

Finally, the filter was simulated using the current spectrum measured in the experiment with and without the ASD. The results of this simulation are shown in Table 2. The model predicts 70 percent more losses with the ASD than without. Note that the major power losses are in the inductor.

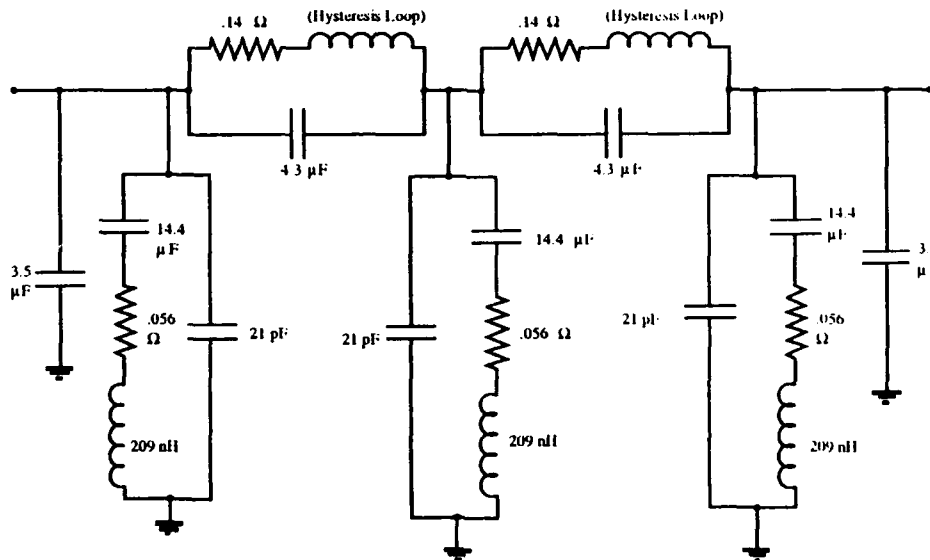

Figure 22. Final Model of Filtron Filter.

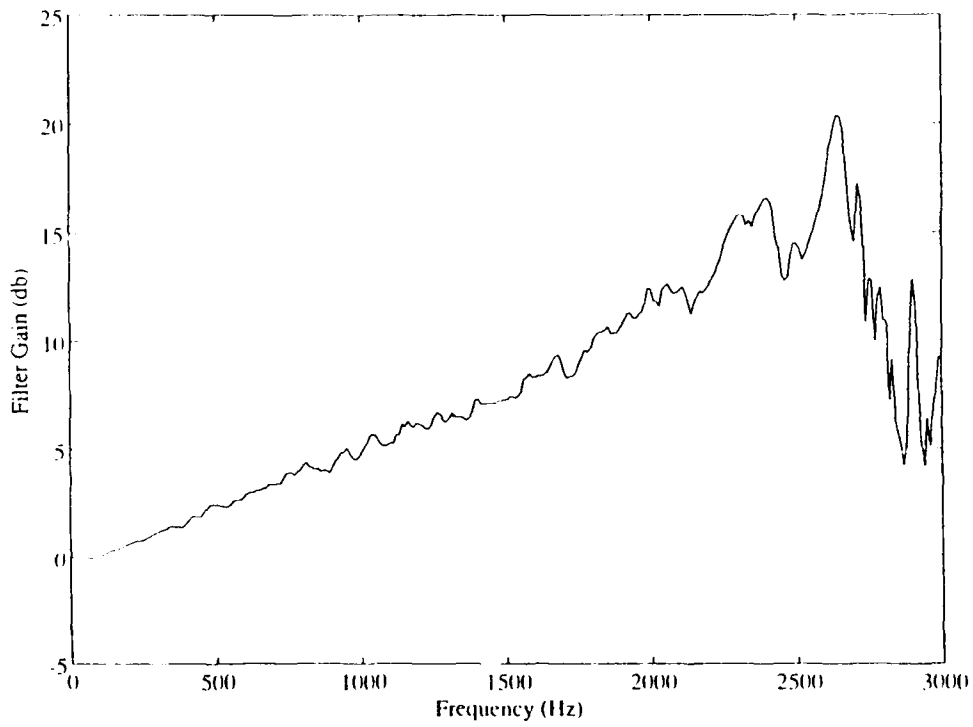

Figure 23. Filtron Modeled Frequency Response.

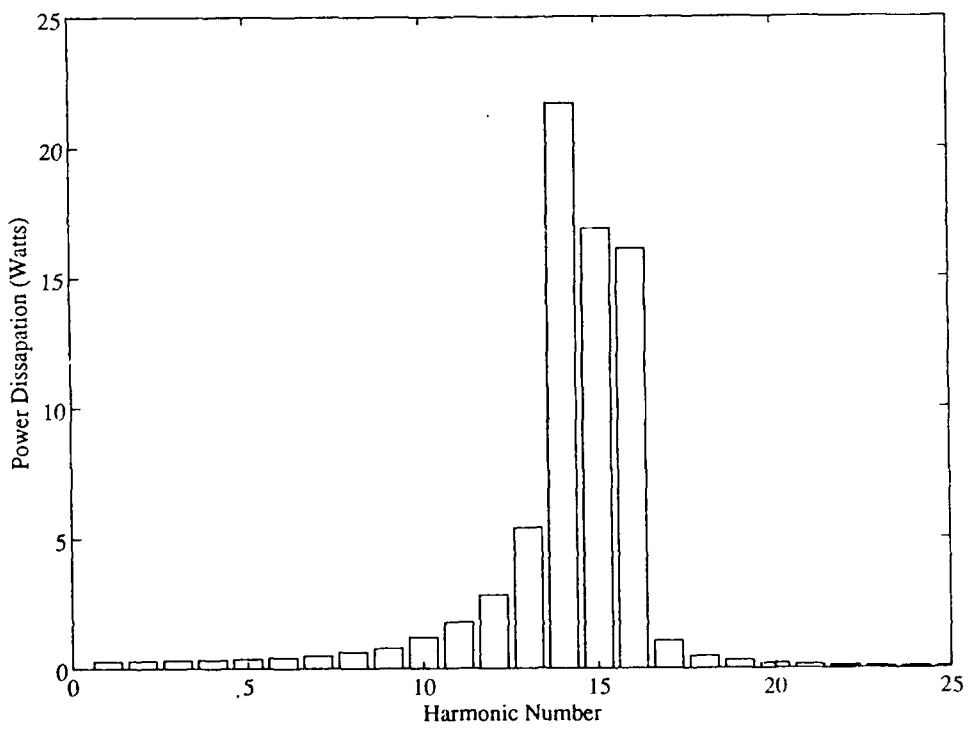

Figure 24. Simulated Power Loss in Filter for 1-Amp Harmonic Current.

Table 2

Simulated Power Loss in Filter

	Without ASD	With ASD
C1	0 Watts	0 Watts
C2	9.3 μ Watts	9.2 μ Watts
C3	37 μ Watts	38 μ Watts
L1	8.6 Watts	14.8 Watts
L2	8.6 Watts	14.8 Watts
Total	17.2 Watts	29.5 Watts

5 DISCUSSION, CONCLUSIONS, AND RECOMMENDATIONS

Discussion of Results

The significant results from the experiment and simulation are the power losses in the Filtron filter for the case with and without the ASD. Experimentally, a loss of 21.4 Watts was measured without the ASD and 45.4 Watts with the ASD, for an increase of 112 percent. The theoretical losses were 17.2 Watts without the ASD and 29.5 Watts with the ASD, for an increase of 72 percent. The difference between experiment and theory can be explained by noting that the model did not take hysteresis losses into account. This was due to the difficulty of accurately modeling hysteresis losses under a complex, nonsinusoidal waveform. However, hysteresis losses for a sinusoidal signal are proportional to the frequency. It is therefore expected that an accurate model, incorporating hysteresis losses, would show the same trends between the linear and nonlinear load cases as the model presented here.

The importance of the filter's frequency-response characteristic in determining power loss cannot be overstated. For example, even though the 60 Hz current through the filter is large with the ASD (Figure 14b), the power loss at 60 Hz (Figure 16) is small due to the filter's characteristics. The large peak in the power spectrum around the 15th harmonic is due more to the filter's characteristics (Figure 24) than to the magnitude of harmonic current demanded by the load. In fact, the 15th and 17th harmonics present in the current and voltage spectrums without the ASD (Figures 11b and 12b) are probably due to nonlinearities within the filter. The difficulty is that the real response characteristic cannot be deduced either from MIL-STD-220A or from the manufacturer's published data on the filter. It can be obtained only by direct testing under harmonic loads or by simulations based on models including effects due to parasitic and lossy components. Attempting to use a response curve based on the manufacturer's component values, such as Figure 17, results in no power loss and in absurdly large voltage gains at harmonic frequencies.

Another significant result is the difference between the Filtron filter and the ARK filter. Even though both filters meet the same standard, MIL-STD-220A, and even though both are available for the same applications, they show significantly different response characteristics in the crucial frequency range of 180 Hz to 3 kHz. This difference results in significantly higher heating effects in the Filtron filter for the particular harmonic spectrum produced by the experimental apparatus. It is important to note that for a different spectrum, the ARK filter might show significantly more heating than the Filtron filter. The power loss in the filter is a complex function of the filter's response characteristic (including parasitic elements), and the harmonic current spectrum.

Conclusions

EMI/RFI filters, as currently rated and specified under MIL-STD-220A, are susceptible to overheating under harmonic loads. The magnitude of this heating is a function of the harmonic current spectrum and the filter's frequency response and power-loss curves in the range of 180 Hz to 3 kHz.

In practice, the harmonic current spectrum is poorly known, and the filter response characteristic is not known at all. It is not sufficient to rely on the published filter response curve or schematic provided by the manufacturer, unless the manufacturer specifically states that the information includes parasitic elements and loss mechanisms, such as harmonic frequency core saturation, that only become significant (show nonlinear effects) when large currents are present in the range of 180 Hz to 3 kHz.

The effects of some harmonics are potentially much more harmful than others. Thus, THD and TDD alone cannot predict with any degree of certainty the level of power-loss increase or decrease.

Recommendations

On existing systems, the installer will derate filters by 50 percent. This means that individual per-phase currents on existing filter installations will be measured to ensure that they do not exceed 50 percent of the rated nameplate of the manufacturer's product. On new installations, the installer will increase the size of the filter by a factor of 2 over the standard full-load current of the installation. The installer will request the manufacturer's test for saturation of the inductors under normal 60-Hz power currents, and under 60-Hz power currents containing 20 percent harmonic distortion in the third and fifth harmonic currents. This information will remain at the installation for review during periodic monitoring.

To verify the safe operation and continued effectiveness of EMI/RFI filters, the installer/operator of the site will monitor on a periodic basis as follows:

1. Measure at least once every 6 months with a true rms amp meter to verify that the total rms currents in the power circuit are no greater than 50 percent of the filter rating.
2. Perform a harmonic analysis at least every 3 years, OR when power quality problems are suspected, OR when significant amounts of equipment are added to the load, OR when significant changes are made to the distribution system feeding the filters.
3. Monitor the filter's temperature at least once every 6 months. If overheating is apparent, take measurements at least every 6 months and compare with the manufacturer's test results for 60 Hz undisturbed, full-load operation.
4. Apply recommended harmonic mitigation techniques when the load currents show harmonics in excess of 20 percent of rated current in either the third or the fifth harmonic, or harmonics in excess of 10 percent for any higher harmonic. These mitigation techniques also should be considered where the harmonic currents exceed the above percentages relative to the fundamental current, particularly if further load growth is anticipated. Re-monitor after installation of these mitigation devices to verify return to an undisturbed 60-Hz operation.
5. If temperature rise measured in item 3 above shows greater than fully rated temperature rise while the system is operating at 50 percent load currents, then measure the leakage of the filter capacitors to ground and compare this with the filter manufacturer's recommendations. This can be accomplished by a dc ohms reading, line to ground, with the filter de-energized.

When monitoring techniques as indicated above reveal excessive harmonic currents requirements in the power circuit (20 percent fundamental levels), the installer/operator will install harmonic mitigation devices to relieve the power system of any high-frequency contribution. This will protect the EMI/RFI filter from high-frequency damage. The recommended form of mitigation will be a harmonic trap tuned to the lowest predominant frequency and consisting of a shunt-connected series inductor/capacitor assembly. After this modification has been placed at the input to the existing equipment containing harmonic distortion, the installer/operator will verify that the power line has returned to a 60-Hz, undisturbed current condition.

REFERENCES

- Heydt, G.T., "The Impact of Power System Harmonics Caused by Industrial Rectifiers and Other Nonlinear Loads." *Proceedings of the First Symposium on Electric Power Systems in Fast Developing Countries* (King Saud University, March 21-24, 1987).
- Military Standard (MIL-STD)-220A, *Method of Insertion-Loss Measurement* (Government Printing Office, March 1978).
- Power Problem Analysis: Defense Intelligence Agency, Building 3100, Clarendon, VA, E-90033* (U.S. Army Engineering and Housing Support Center, March 1990).
- Subjak, J.S., and J.S. McQuilken, "Harmonics - Causes, Effects, Measurements, and Analysis: An Update," *IEEE Transactions on Industrial Applications*, Vol 26, No. 6 (Institute of Electrical and Electronics Engineers [IEEE], November/December 1990), pp 1034-1042.
- Wong, C.C., "A Dynamic Hysterisis Model," *IEEE Transactions on Magnetics*, Vol 24, No. 2 (March 1988), pp 1966-1968.

UNCITED REFERENCES

- Claussen, H., *Harmonic Distortion in AC Power Systems* (Technical Power Services, 1991).
- Emerald Book, *IEEE Recommended Practice for Powering and Grounding Sensitive Electronic Equipment*, IEEE Std P-1100 (IEEE, 1992).
- Wagoner, R., *Recommended Practices and Problem Solving for Sensitive Electronics* (Enteg Systems Inc, January 1993).

USACERL DISTRIBUTION

Chief of Engineers
 ATTN: CEHEC-IM-LH (2)
 ATTN: CEHEC-IM-LP (2)
 ATTN: CECG
 ATTN: CERD-M
 ATTN: CECC-P
 ATTN: CERD-L
 ATTN: CECW-P
 ATTN: CECW-PR
 ATTN: CEMP-E
 ATTN: CEMP-C
 ATTN: CECW-O
 ATTN: CECW
 ATTN: CERM
 ATTN: CEMP
 ATTN: CERD-C
 ATTN: CEMP-M
 ATTN: CEMP-R
 ATTN: CERD-ZA
 ATTN: DAEN-ZCM
 ATTN: DAEN-ZCE
 ATTN: DAEN-ZCI

CEHSC
 ATTN: CEHSC-F 22060
 ATTN: CEHSC-TT 22060
 ATTN: CEHSC-ZC 22060
 ATTN: DET III 79906

US Army Engr District
 ATTN: Library (40)

US Army Engr Division
 ATTN: Library (13)

US Army Europe
 ATTN: AEAEN-EH 09014
 ATTN: AEAEN-ODCS 09014
 V Corps
 ATTN: DEH (8)
 VII Corps
 ATTN: DEH (11)
 29th Area Support Group
 ATTN: AERAS-FA 09054
 100th Support Group
 ATTN: AETT-EN-DEH 09114
 222d Base Battalion
 ATTN: AETV-BHR-E 09034
 235th Base Support Battalion
 ATTN: Unit 28614 Ansbach 09177
 293d Base Support Battalion
 ATTN: AEUSG-MA-AST-WO-E 09086
 409th Support Battalion (Base)
 ATTN: AETTG-DEH 09114
 412th Base Support Battalion 09630
 ATTN: Unit 31401
 Frankfurt Base Support Battalion
 ATTN: Unit 25727 09242
 CMTC Hohenfels 09173
 ATTN: AETHH-DEH
 Mainz Germany 09185
 ATTN: BSB-MZ-E
 21st Support Command
 ATTN: DEH (10)
 US Army Berlin
 ATTN: AEBA-EH 09235
 ATTN: AEBA-EN 09235
 SETAP
 ATTN: AESE-EN-D 09613
 ATTN: AESE-EN 09630
 Supreme Allied Command
 ATTN: ACSGEB 09703
 ATTN: SHIHB/ENGR 09705

4th Infantry Div (MECH)
 ATTN: AFZC-FE 80913

Fort Pickett 23824
 ATTN: AFZA-PP-E

Tobyhanna Army Depot 18466
 ATTN: SDSTO-EH

US Army Materiel Command (AMC)
 Redstone Arsenal 35809
 ATTN: DESMI-KLF
 Jefferson Proving Ground 47250
 ATTN: STEJP-LD-F/DEH
 Letterkenny Army Depot
 ATTN: SDSLE-ENN 17201
 Pueblo Army Depot 81008
 ATTN: SDSTE-PUI-F
 Dugway Proving Ground 84022
 ATTN: STEDP-EN
 Tooele Army Depot 84074
 ATTN: SDSTE-ELF
 Yuma Proving Ground 85365
 ATTN: STEYP-EH-E
 Tobyhanna Army Depot 18466
 ATTN: SDSTO-EH
 Seneca Army Depot 14541
 ATTN: SDSSE-HE
 Aberdeen Proving Ground
 ATTN: STEAP-DEH 21005
 Sharpe Army Depot 95331
 ATTN: SDSSE-E
 Fort Monmouth 07703
 ATTN: SELPM-EH-E
 Savanna Army Depot 61074
 ATTN: SDSLE-VAE
 Rock Island Arsenal
 ATTN: SMCRI-EH
 ATTN: SMCRI-TL
 Watervliet Arsenal 12189
 ATTN: SMCVV-EH
 Red River Army Depot 76102
 ATTN: SDSRR-G
 Harry Diamond Lab
 ATTN: Library 20783
 White Sands Missile Range 88002
 ATTN: Library
 Corpus Christi Army Depot
 ATTN: SDSCC-ECD 78419

FORSCOM
 ATTN: Facilities Engr (12)
 Fort Bragg 28307
 ATTN: AFZA-DE
 Fort Campbell 42223
 ATTN: APZB-DEH
 Fort McCoy 54656
 ATTN: APZR-DE
 Fort Stewart 31314
 ATTN: APZP-DEF
 Ft Buchanan 00934
 ATTN: Envr Office
 Ft Devens 01433
 ATTN: APZD-DE
 Fort Drum 13602
 ATTN: AFZS-EH-E
 Fort Irwin 92310
 ATTN: APZJ-EH
 Fort Hood 76544
 ATTN: APZF-DE-AES Engr
 Fort Meade 20755
 ATTN: AFKA-ZI-EH A

6th Infantry Division (Light)
 ATTN: APVR-DE 99505
 ATTN: APVR-WF-DE 99701

National Guard Bureau 20300 20
 ATTN: NGB-ARI

Fort Belvoir 22060
 ATTN: CECEC-IM-T
 ATTN: CECC-R 22060
 ATTN: Engr Strategic Studies Ctr
 ATTN: Australian Liaison Office

USA Nauck RD&E Center 01760
 ATTN: STRNC-DT
 ATTN: DRDNA-F

TRADOC
 ATTN: DEH (13)
 Fort Monroe 23651
 ATTN: ATBO-G
 Cadiz Barracks 17013
 ATTN: ATZE-DIS
 Fort Eustis 23604
 ATTN: DEH
 Fort Chaffee 72905
 ATTN: ATZR-ZF
 Fort Sill 73503
 ATTN: ATZR-E

US Army Materials Tech Lab
 ATTN: SLCMT-DEH 02172

WESTCOM 96858
 ATTN: DEH
 ATTN: APEN A

SHAPE 09705
 ATTN: Infrastructure Branch LANDA

Area Engineer, AEDC Area Office
 Arnold Air Force Station, TN 37389

HQ USEUCOM 09128
 ATTN: ECM-LIE

AMMRC 02172
 ATTN: DRXMR-AF
 ATTN: DRXMR-WE

CEWES 39180
 ATTN: Library

CECL 03755
 ATTN: Library

USA AMCOM
 ATTN: Facilities Engr 21719
 ATTN: AMSMC-IR 61299
 ATTN: Facilities Engr (3) 85613

USAARMC 40121
 ATTN: ATZIC-EHA

Military Traffic Mgmt Command
 ATTN: MTEA-GB-EHP 07002
 ATTN: MT-LOF 20315
 ATTN: MTE-SU-FE 28461
 ATTN: MTW-IE 94626

Fort Leonard Wood 65473
 ATTN: ATSE-DAC-LB (3)
 ATTN: ATZA-TE-SW
 ATTN: ATSE-CFLO
 ATTN: ATSE-DAC-FL

Military Dist of WASH
 Fort McNair
 ATTN: ANEN 20319

USA Engr Activity, Capital Area
 ATTN: Library 22211

Norton AFB 92409
 ATTN: Library

US Army ARDEC (7806)
 ATTN: SMCAR-ISE

Charles E Kelly Spt Activity
 ATTN: DEH 15071

Engr Societies Library
 ATTN: Acquaintance 10017

Defense Nuclear Agency
 ATTN: NALUS 20305

Defense Logistics Agency
 ATTN: DLA WI 22304

Walter Reed Army Medical Ctr 20307

US Military Academy 10996
 ATTN: MAEN-A
 ATTN: Facilities Engineer
 ATTN: Geography & Envr Engrg

416th Engineer Command 60623
 ATTN: Gibson USAR Ctr

USA Japan (USARJ)
 ATTN: APAJ-EN-ES 96343
 ATTN: HONSHU 96343
 ATTN: DEH Okinawa 96376

Naval Facilities Engr Command
 ATTN: Facilities Engr Command (8)
 ATTN: Division Offices (11)
 ATTN: Public Works Center (8)
 ATTN: Naval Constr Battalion Ctr 93043
 ATTN: Naval Civil Engr Laboratory (3) 93043

8th US Army Korea
 ATTN: DEH (12)

US Army HSC
 Fort Sam Houston 78234
 ATTN: HSLO-F
 Fitzsimons Army Medical Ctr
 ATTN: HSHG-DEH 80045

Tyndall AFB 32403
 ATTN: AFESC Program Ofc
 ATTN: Engrg & Svc Lab

Chanute AFB 61868
 ATTN: 3345 CES/DE

USA TSARCOM 63120
 ATTN: STSAS-F

American Public Works Assoc 64104-1806

US Army Envr Hygiene Agency
 ATTN: HSHB-ME 21010

US Gov't Printing Office 20401
 ATTN: Rec Sec/Deposit Sec (2)

Nat'l Institute of Standards & Tech
 ATTN: Library 20899

Defense Tech Info Center 22304
 ATTN: DTIC-FAB (2)

302
 03/93

INSCOM
 ATTN: IALOG-I 22060
 ATTN: IAV-DEH 22186

USA TACOM 48397
 ATTN: AMSTA-XE

Defense Distribution Region East
 ATTN: DDRB-WI 17070

HQ XVIII Airborne Corps 28307
 ATTN: AFZA-DEH-EE