

Naval Research Laboratory

Stennis Space Center, MS 39529-5004



2

AD-A269 989

NRL/FR/7441--92-9408



The Navy Tessellated Spheroid Map Projection System: A Comprehensive Definition

MAURA C. LOHRENZ
MICHAEL E. TRENCHARD
STEPHANIE A. MYRICK
PERRY B. WISCHOW

*Mapping, Charting, and Geodesy Branch
Marine Geosciences Division*

LANCELOT M. RIEDLINGER

*Planning Systems, Inc.
Slidell, LA 70458*

DTIC
ELECTE
SEP 21 1993
S B D

August 11, 1993

*original contains color
plates! All DTIC reproductions
will be in black and
white*

Approved for public release; distribution is unlimited.

93-21879



9 9 20 07 3

DISCLAIMER NOTICE



THIS DOCUMENT IS BEST QUALITY AVAILABLE. THE COPY FURNISHED TO DTIC CONTAINED A SIGNIFICANT NUMBER OF COLOR PAGES WHICH DO NOT REPRODUCE LEGIBLY ON BLACK AND WHITE MICROFICHE.

REPORT DOCUMENTATION PAGE

Form Approved
OBM No. 0704-0188

Public reporting burden for this collection of information is estimated to average 1 hour per response, including the time for reviewing instructions, searching existing data sources, gathering and maintaining the data needed, and completing and reviewing the collection of information. Send comments regarding this burden or any other aspect of this collection of information, including suggestions for reducing this burden, to Washington Headquarters Services, Directorate for Information Operations and Reports, 1215 Jefferson Davis Highway, Suite 1204, Arlington, VA 22202-4302, and to the Office of Management and Budget, Paperwork Reduction Project (0704-0188), Washington, DC 20503.

1. AGENCY USE ONLY (Leave blank)		2. REPORT DATE August 11, 1993	3. REPORT TYPE AND DATES COVERED Final	
4. TITLE AND SUBTITLE The Navy Tessellated Spheroid Map Projection System: A Comprehensive Definition			5. FUNDING NUMBERS <i>Job Order No.</i> 574526903 <i>Program Element No.</i> 0604233N <i>Project No.</i> <i>Task No.</i> <i>Accession No.</i> DN257017	
6. AUTHOR(S) Maura C. Lohrenz, Michael E. Trenchard, Stephanie A. Myrick, Perry B. Wischow, and Lancelot M. Riedlinger*				
7. PERFORMING ORGANIZATION NAME(S) AND ADDRESS(ES) Naval Research Laboratory Marine Geosciences Division Stennis Space Center, MS 39529-5004			8. PERFORMING ORGANIZATION REPORT NUMBER NRL/FR/7441--92-9408	
9. SPONSORING/MONITORING AGENCY NAME(S) AND ADDRESS(ES) Naval Air Systems Command Department of the Navy (AIR-803) Washington, DC 20361-8030			10. SPONSORING/MONITORING AGENCY REPORT NUMBER	
11. SUPPLEMENTARY NOTES *Planning Systems, Inc. Slidell, LA 70458				
12a. DISTRIBUTION/AVAILABILITY STATEMENT Approved for public release; distribution unlimited.			12b. DISTRIBUTION CODE	
13. ABSTRACT (Maximum 200 words) This report describes a map projection model, called the Tessellated Spheroid (TS), which provides a seamless, global framework in which to store scanned chart data and, potentially, other types of spatial data as well. The Compressed Aeronautical Chart (CAC) is being developed at the Naval Research Laboratory in direct support of tactical Navy and Marine Corps aircraft mission planning systems and digital moving map systems. Aircraft programs that currently utilize the CAC database include the AV-8B Harrier, F/A-18 Hornet, and V-22 Osprey. There has been recent interest in using the TS system to store datasets other than CAC: the newly formed A-X program (which replaced the A-12 program) is interested in storing the Defense Mapping Agency Digital Landmass System data in the TS model; other programs have shown interest in storing scanned nautical charts and satellite imagery in the TS system and, possibly, compressing that data in the same manner in which the CAC data is compressed. Following a detailed description of the TS model, this report discusses certain issues that must be addressed before the TS model can be applied to databases other than the original CAC. The most pressing issue relates to geographic scale. The CAC database includes six "scale-models" of chart data: 1:50k (k = thousand), 1:100k, 1:250k, 1:500k, 1:1M (M = million), and 1:2M. All TS parameters are based on the 1:2M scale-model, and any additional scales that are to utilize TS must be an integral divisor of 2,000,000. In addition, the TS segment file naming convention currently stipulates a maximum of 9000 TS segment rows, but scales that are larger than approximately 1:50k have more than 9000 rows. These restrictions do not necessarily prohibit additional scales of data from utilizing TS, but they must be addressed before any new scales are added to the TS model. Several potential solutions are suggested in this report, the most promising of which would allow any scale model (either larger or smaller than 1:50k) to coexist in the TS model without modifying the TS specification for existing systems.				
14. SUBJECT TERMS digital maps, optical storage, databases, data compression			15. NUMBER OF PAGES 28	
			16. PRICE CODE	
17. SECURITY CLASSIFICATION OF REPORT Unclassified	18. SECURITY CLASSIFICATION OF THIS PAGE Unclassified	19. SECURITY CLASSIFICATION OF ABSTRACT Unclassified	20. LIMITATION OF ABSTRACT Same as report	

CONTENTS

BACKGROUND	1
INTRODUCTION TO TESSELLATED SPHEROID	2
TS ZONE BOUNDARIES AND OVERLAP REGIONS	3
TS COORDINATES	3
TS SEGMENTS	4
Segment Organization	4
Segment Numbering	4
Segment Files	4
Determining Segment Size	8
Pixels	10
Number of Rows of TS Segments	11
Number of Columns of TS Segments	12
Calculating TS Row and Column from Latitude and Longitude	13
Calculating Latitude and Longitude Coordinates for TS Segment at Given Row and Column Location	18
TS POLAR ROTATIONS	18
Rotation from Polar Coordinates to Equatorial Coordinates	18
Rotation from Equatorial Coordinates to Polar Coordinates	19
DOWNSAMPLING FROM ARC TO TS	20
TS PROJECTION DISTORTION	21
APPLYING TS TO DATABASES OTHER THAN CAC	25
Distortion Due to Scale Incompatibility	25
TS Segment Row Limits	26
CONCLUSIONS AND RECOMMENDATIONS	26
ACKNOWLEDGMENTS	27
REFERENCES	27

DTIC QUALITY INSPECTED 1

Availability Codes	
Dist	Avail and/or Special
A-1	

THE NAVY TESSELLATED SPHEROID MAP PROJECTION SYSTEM: A COMPREHENSIVE DEFINITION

BACKGROUND

With the introduction of digital moving map systems aboard tactical Navy and Marine Corps aircraft, a pilot's use of paper map products is quickly changing to a reliance on digital maps. A digital moving map system provides a pilot with precise, hands-off navigation and route selection. This system was originally designed for night-attack air missions, since it provides valuable positional information at night when visual flight navigation is often impossible. A digital map computer stores all of the charts that are required by the pilot for a particular mission. Additionally, the system allows the pilot to display new threat and intelligence information, or other data, as overlays onto the base chart.

The Map Data Formatting Facility (MDFF) at the Naval Research Laboratory (NRL) is developing the Compressed Aeronautical Chart (CAC) database in direct support of aircraft digital moving map systems. CAC is derived from Defense Mapping Agency (DMA) ARC (Equal Arc-second Raster Chart) Digitized Raster Graphics (ADRG), which consists of full-color charts that have been scanned into 100- μ m pixels. Each pixel consists of a red, green, and blue (RGB) component. The MDFF "downsamples" ADRG data from 100- μ m pixels (which provide an image resolution of 254 ppi [pixels per inch]) to approximately 200- μ m pixels (exactly 128 ppi), which results in a 4:1 reduction in data storage. The lower resolution data are then color-compressed by a factor of 3:1 and, finally, spatially compressed by a factor of 4:1 (Lohrenz et al. 1991). The final CAC product represents a data storage compression of 48:1 over the original ADRG. Readers are referred to Lohrenz and Ryan (1990) for a detailed CAC product specification.

CAC is stored as a seamless, global database such that the transition from one source chart to another is transparent to the pilot. The data are stored in discrete 51 mm² (2 in.²) sections of chart, called tessellations or segments, which cover the entire globe; the model is known as a tessellated sphere (Fig. 1). Approximately four chart segments may be projected onto the digital moving map display at one time.

The purpose of this report is to completely describe the CAC Tessellated Spheroid (TS)* map projection system so it can be applied to other databases of interest to mission planners. The TS model used for the CAC database was originally referred to as the Model IV Tessellated Sphere, or TS-4 (Ronish 1986). It has since been shortened to TS. The TS model was originally conceived by Honeywell, Inc. (Ronish 1986; Honeywell 1990) for the CAC database.

*Note that, in this report, "TS" refers to the specific Tessellated Spheroid model that is used for the CAC database.

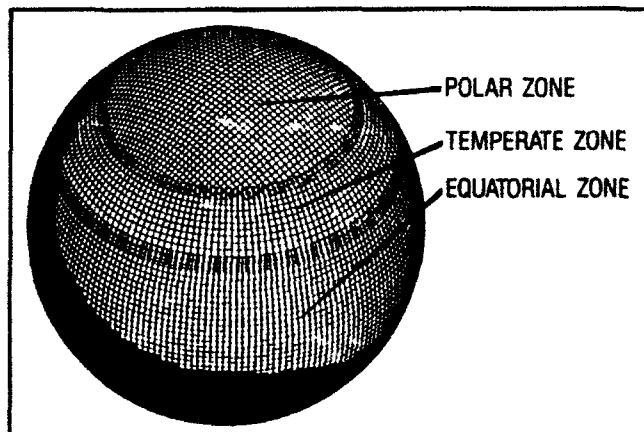

Fig. 1 — Model of globe overlaid with TS segments

INTRODUCTION TO TESSELLATED SPHEROID

Tessellated spheroids provide a rectangular coordinate and projection system at any scale for the entire earth ellipsoid. During the conversion from ADRG to CAC, data are transformed from one tessellated spheroid model (the DMA ARC projection system) into TS. Although there are several characteristic differences between the ARC and TS models, as presented in Table 1, the models are functionally similar.

- a. Both are rectangular coordinate systems for the entire earth ellipsoid.
- b. For both, the earth is divided into latitudinal bands with a slight overlap between adjacent bands.
- c. Bands in both systems are subdivided into segments that are bounded by fixed latitude and longitude lines.
- d. Segments in both systems are divided into pixels. Each pixel is associated with a fixed latitude and longitude point and an RGB value.
- e. All latitude and longitude coordinates in both ADRG and CAC have been adjusted to conform to the World Geodetic System of 1984 (WGS 84) if the source charts do not already conform to this standard.

Table 1 — Major Differences Between ARC and TS

Categories	ARC Values (DMA 1989)	TS Values
# Latitude Bands	18	5
Pixel Spacing	100 μm	200 μm
Segment Size	12.7 mm (0.5 in.) square	51 mm (2 in.) square
# Pixels/Segment	127 \times 127	256 \times 256
Polar Zone Projection	Polar Azimuthal Equidistant	Rotated EQ Zone

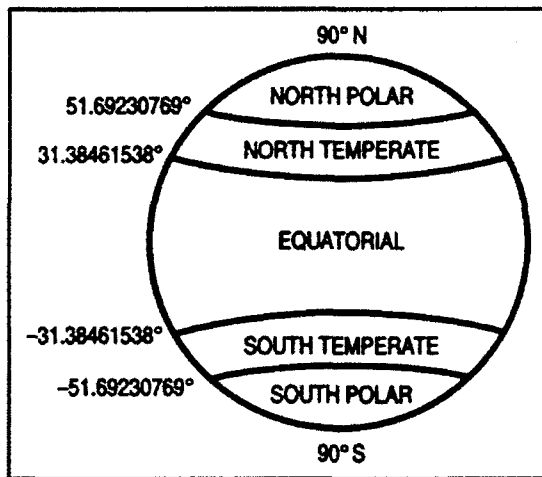

Fig. 2 — TS zones with latitudinal boundaries and overlap definitions

TS ZONE BOUNDARIES AND OVERLAP REGIONS

The TS projection system divides the surface of the earth into five latitudinal bands, called zones, which are numbered from 0 to 4. Two of these zones—North Polar (NP) and South Polar (SP)—cover the poles, and each of the three nonpolar zones—North Temperate (NT), Equatorial (EQ), and South Temperate (ST)—completely encircles the earth between two fixed latitude limits (see Fig. 2 and Table 2).

A region of overlap is defined between each pair of neighboring TS zones, as indicated in Figs. 1 and 2. This overlap consists of an extension of one zone into an adjacent zone by two rows of segments, where each segment consists of 256×256

pixels. Thus, each region of overlap consists of a total of 1024 pixels (512 pixels overlap northward from the southern zone, and 512 pixels overlap southward from the northern zone). For example, two additional rows of NT segments are added to the southern boundary of the NT zone (at 31.385° N) and extend into the EQ zone. Similarly, two additional rows of EQ segments are added to the northern boundary of the EQ zone (at 31.385° N) and extend into the NT zone. Therefore, the CAC database stores each section of overlap data twice: once as part of one zone and again as part of the adjacent zone. The amount of geographic overlap (in degrees of latitude) between zones is dependent upon the scale of the data (see Table 3).

TS COORDINATES

Coordinates in the nonpolar zones are directly proportional to the WGS 84 coordinates θ and λ (latitude and longitude). Specifically, the latitudinal and longitudinal spacing of pixels is constant throughout any given nonpolar zone. Coordinates in the polar zones have been derived by a rotation of the equatorial zone's coordinate grid over the polar regions, as defined in a later section of this report. WGS 84 coordinates θ and λ in CAC are signed values such that $-90^\circ \leq \theta \leq +90^\circ$, and $-180^\circ \leq \lambda \leq +180^\circ$. The λ values outside this range should be adjusted by $\pm 360^\circ$ as appropriate.

Table 3 — Extents of TS Zone Overlap

Scale	Zone Overlap
1:2,000,000	$\pm 1.84615385^\circ$
1:1,000,000	$\pm 0.92307692^\circ$
1:500,000	$\pm 0.46153846^\circ$
1:250,000	$\pm 0.23076923^\circ$
1:100,000	$\pm 0.09230769^\circ$
1:50,000	$\pm 0.04615385^\circ$

Table 2 — TS Zones

Zone	Name	S. Limit–N. Limit (Excluding Overlap)
0	South Polar	90.00000000° S – 51.69230769° S
1	South Temperate	51.69230769° S – 31.38461538° S
2	Equatorial	31.38461538° S – 31.38461538° N
3	North Temperate	31.38461538° N – 51.69230769° N
4	North Polar	51.69230769° N – 90.00000000° N

TS SEGMENTS

Segment Organization

Each TS zone is divided into spherical rectangular segments. In the equatorial and temperate zones, these segments are arranged by rows and columns, the boundaries of which are lines of constant latitude and longitude. Figure 3 presents a section of nonpolar CAC data overlaid with a grid of segments, and Fig. 4 presents a section of polar CAC data overlaid with segments. The polar zone segment boundaries are defined by a rotation of the equatorial segment grid onto the polar regions. This rotated equatorial grid was extended to cover the entire polar zone, which is larger than the equatorial zone by approximately 13.85° of latitude. Figure 5 depicts the orientation of both grids (a polar coordinate grid overlaid by a rectilinear, rotated equatorial, segment grid) for the entire NP region.

Segment Numbering

Nonpolar segments are arranged by latitudinally based rows and longitudinally based columns. Polar zone segments are arranged by latitudinally based rows and longitudinally based columns within the rotated equatorial grid system. In both cases, row 0 is located with its southern boundary on the equator, as shown in Fig. 6a. Positively numbered rows extend northward from row 0 in the northern hemisphere, and negatively numbered rows extend southward from row -1 in the southern hemisphere. The first column of segments in each nonpolar zone (column 0) is located with its western boundary on the 0° meridian (Fig. 6b). Positive columns extend eastward from column 0 and stop at the 180° meridian (Fig. 6c). Negative columns extend westward from column -1 and stop at the 180° meridian. Table 4 lists the TS scale models and gives for each the number of segment rows and columns in the equatorial and temperate zones, excluding overlap. To include overlap, the number of rows would be increased by four (two rows for overlap on the northern edge of the zone, plus two rows for overlap on the southern edge). Calculations for the numbers of rows and columns, as given in Table 4, are provided later in this report.

Segment Files

After color compression, each TS segment is stored (in the CAC database) as a single, compressed, raster image file. The compressed segment file-naming convention is xxxxxxxx.xx.z, where xxxxxxxx.xx is the same key name that was previously described (xxxxxxx in the uncompressed filename), and z defines the TS zone in which the map segment resides (z = a value between 0 and 4, as listed in Table 2). The key name (xxxxxxx in the uncompressed file, or xxxxxxxx.xx in the compressed file) is derived as follows:

$$\text{KEY} = [((2 \times \text{MaxRow}) + 1) \times (\text{COL} + \text{MaxRow})] + \text{ROW} + \text{MaxRow} + 1$$

where MaxRow = 9000 and ROW, COL = row and column numbers of TS segment. Conversely, the segment's row and column numbers can be derived from the segment filename key:

$$\text{ROW} = \text{mod}((\text{KEY} - 162018001), 18001)$$

$$\text{COL} = ((\text{KEY} - 162018001) - \text{ROW})/18001$$

where mod (short for modulus) is a software function that returns the quantity that remains after the first argument (KEY - 162018001) is divided by the second (18001).



Fig. 3 — Nonpolar CAC data overlaid with segment grid

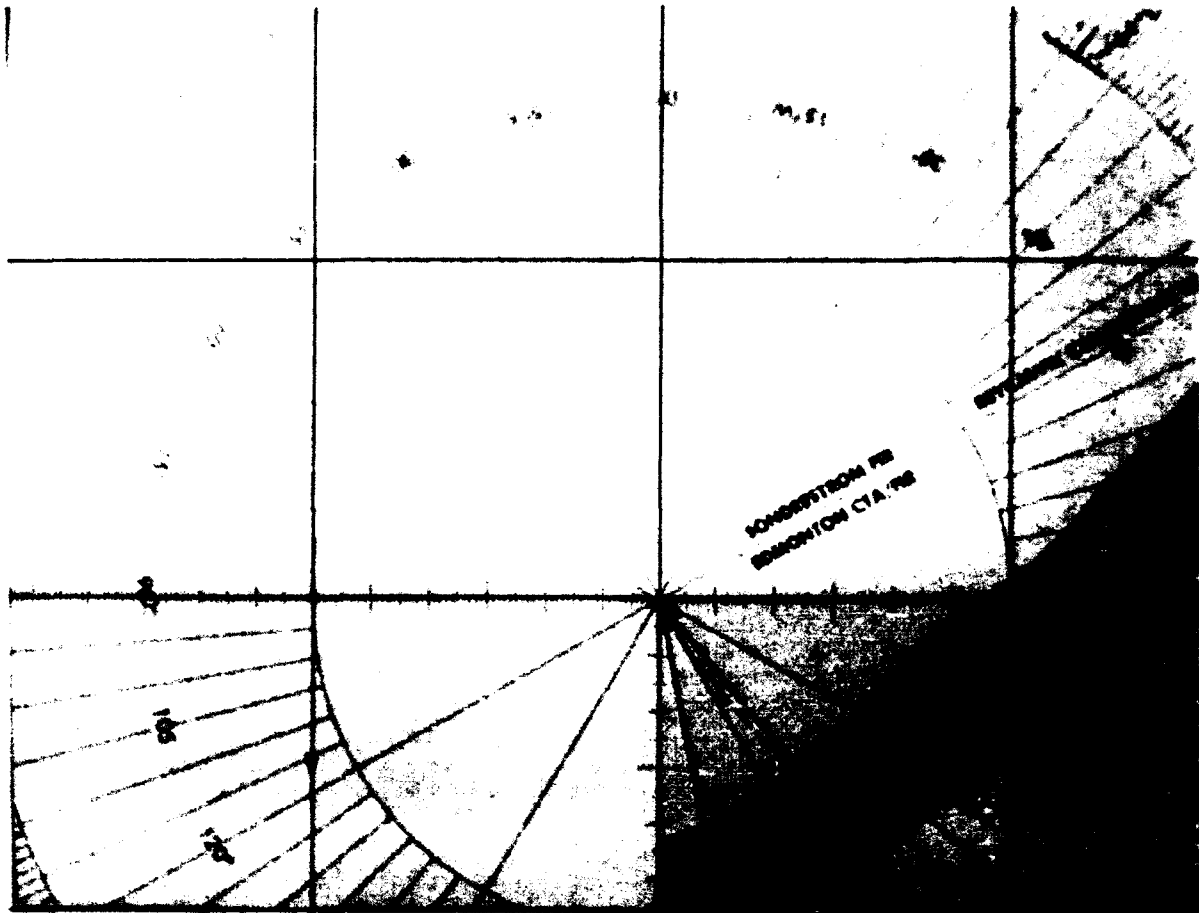

Fig. 4 -- Polar CAC data overlaid with segment grid

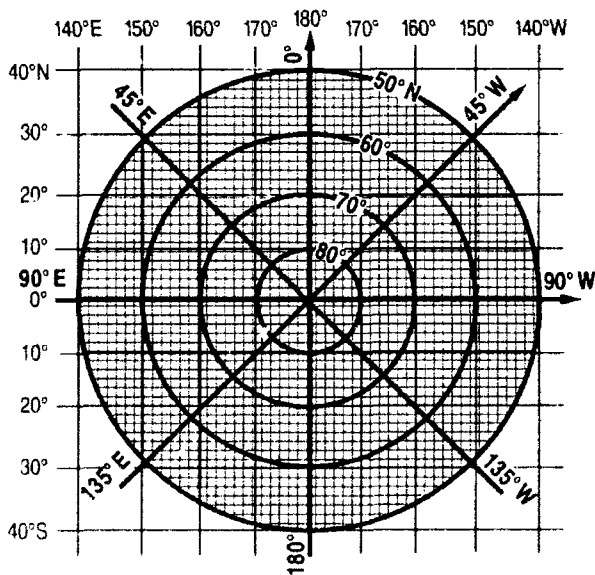

Fig. 5 -- North polar zone coordinate system overlaid with rotated equatorial segment grid

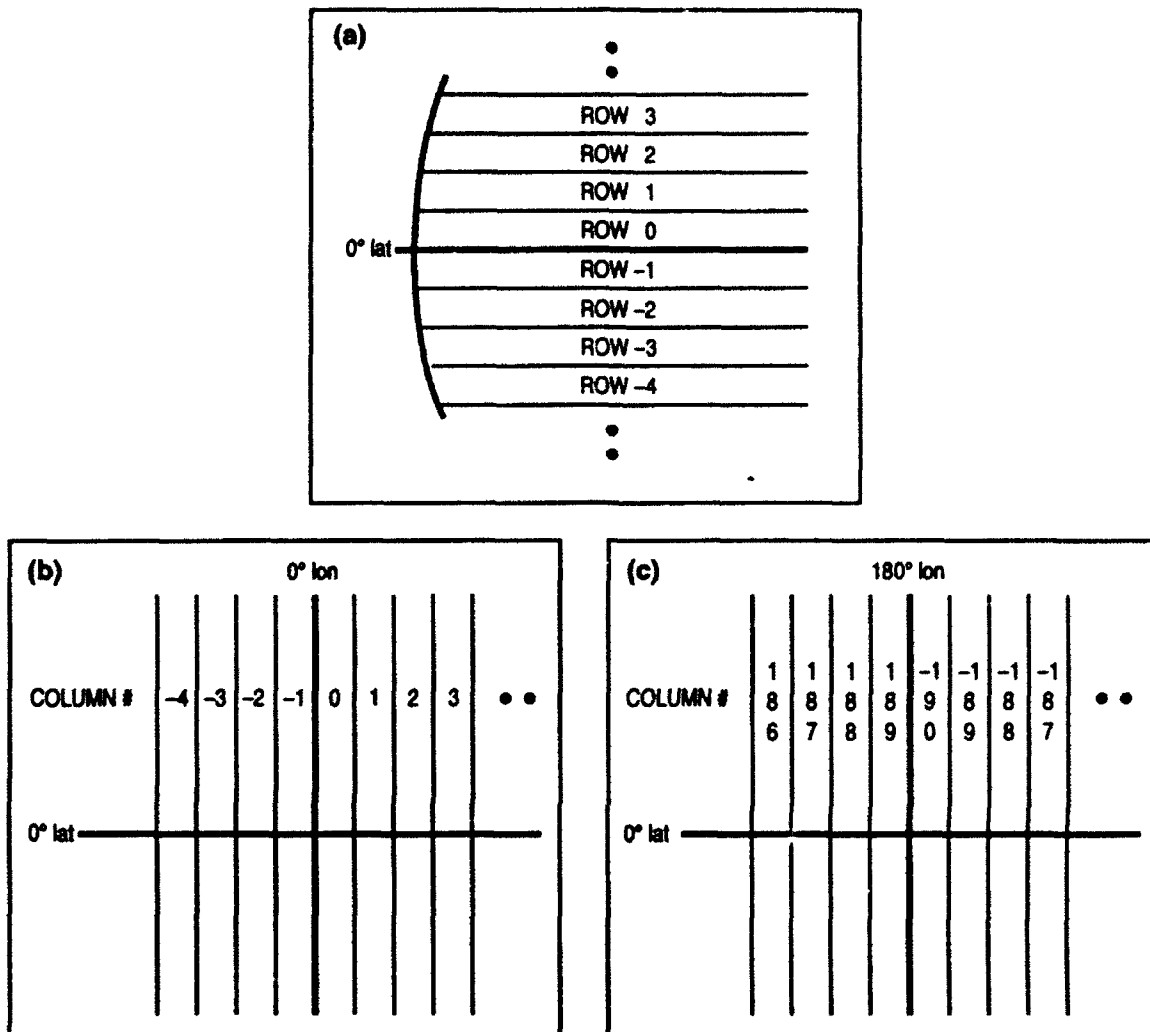

Fig. 6 — TS segment row and column numbering scheme: (a) origin for row numbering, (b) column numbering at 0° longitude, and (c) column numbering at 180° longitude (1:2M scale, EQ zone)

Table 4 — Numbers of Segment Rows and Columns in Each i'S Scale Model

Scale	Equatorial		Temperate	
	# Cols of Segments	# Rows of Segments	# Cols of Segments	# Rows of Segments
1:2,000,000	380	68	304	22
1:1,000,000	760	136	608	44
1:500,000	1520	272	1216	88
1:250,000	3040	544	2432	176
1:100,000	7600	1360	6080	440
1:50,000	15200	2720	12160	880

Determining Segment Size

Six scales of chart are included in the CAC database, ranging from 1:50k (k = thousand) to 1:2M (M = million) (Table 5). The scale of 1:2M is used as the base scale in calculating TS segment sizes; each segment in the 1:2M scale model contains an integral number of segments of any other scale model. Data at any other scale that will utilize the TS system must be an integral divisor of this base scale. Table 6 lists the TS scale models that are used in the CAC database and gives their segment sizes for equatorial and temperate zones. The following discussion explains how these TS segment sizes are derived. For inexact values, excess significant digits are retained to maximize accuracy in the calculations. Unless otherwise noted, parameters were first defined by Ronish (1986), and all conversions between English and metric units of measurement are taken from Beyer (1979).

Four TS segments can be displayed simultaneously on the cockpit screen, which is 127 mm² (5 in.²) square. A "human factors number" of magnitude 1.316, which is incorporated into the area coverage calculations, enlarges the data and performs an adjustment for the fact that the cockpit screen can display only 484 × 484 pixels of the four segments' 512 × 512 pixel area at one time. The length of one edge of a 512 × 512 pixel area is (127 mm/1.316) × (512/484) = 102.0874677 mm² (4.02 in.²).

Table 5 — TS Scale Models and Source Charts
Used in CAC

Scale	DMA Source Chart
1:2,000,000	JNC (Jet Navigation Chart)
1:1,000,000	ONC (Operational Navigation Chart)
1:500,000	TPC (Tactical Pilotage Chart)
1:250,000	JOG (Joint Operational Graphic)
1:100,000	TLM (Topographic Line Map)
1:50,000	TLM (Topographic Line Map)

Table 6 — Segment Sizes for Each TS Scale Model

Scale	Equatorial Zone		Temperate Zones	
	Height (°lat)	Width (°lon)	Height (°lat)	Width (°lon)
1:2,000,000	0.92307692	0.94736842	0.92307692	1.18421053
1:1,000,000	0.46153846	0.47368421	0.46153846	0.59210526
1:500,000	0.23076923	0.23684211	0.23076923	0.29605263
1:250,000	0.11538462	0.11842105	0.11538462	0.14802632
1:100,000	0.04615385	0.04736842	0.04615385	0.05921053
1:50,000	0.02307692	0.02368421	0.02307692	0.02960526

Therefore, one segment (which consists of 256×256 pixels) covers a $102.0874677 \text{ mm}^2 = 51.04373385 \text{ mm}^2$ (2.01 in.^2) portion of a paper chart. The TS system identifies the location of each segment by a row and column number, which corresponds to latitudinal (LAT) and longitudinal (LON) location, respectively. The LAT and LON extent of each segment is based on an attempt to approximate a 51.04373385 mm^2 area. The radius and circumference of the earth (assuming a spherical earth), represented at a scale of 1:2M, are required in the row and column calculations. Ronish (1986) assumed an earth radius of 125.3264963 in. at the 1:2M scale ($3,437.74677 \text{ nmi} \times 6076 \text{ ft/nmi} \times 12 \text{ in./ft} \times 2,000,000$). This value translates to 3,183.293006 mm:

$$\begin{aligned} \text{RAD}^{2M} &= \text{Earth radius @ 1:2M} \\ &= 3,183.293006 \text{ mm} \end{aligned}$$

$$\begin{aligned} \text{CIR}^{2M} &= \text{Earth circumference @ 1:2M} \\ &= 2 \pi \times \text{RAD}^{2M} \\ &= 2 \times 3.141592654 \times 3,183.293006 \text{ mm} \\ &= 20,001.21985 \text{ mm} \end{aligned}$$

Since each row of TS segments completely surrounds the spherical earth, the number of rows of segments is calculated from the distance along a semicircle of constant longitude running from one pole to the other:

$$\begin{aligned} \# \text{ rows} &= (\text{CIR}^{2M}/2)/\text{height of 1 segment of paper chart} \\ &= (20,001.21985 \text{ mm}^2)/51.04373385 \text{ mm} \\ &= 195.9223822 \end{aligned}$$

The number of rows is truncated to 195 to avoid the difficulties in trying to display a fractional number of rows. Conversion from the data spacing in the segments to the data spacing for the equal area display is obtained by resampling the segment pixel data to the spacing of the display pixels. This vertical resampling is called the latitudinal screen correction factor (LSC):

$$\begin{aligned} \text{LSC} &= 195/195.9223822 \\ &= 0.9952921 \end{aligned}$$

For a particular map scale (known as a "scale model"), and for a given zone, the width and height in degrees of a segment is constant. The number of segments per row or column of a given zone is proportional to the scale. For example, the 1:1M scale model has twice as many segments around the equator as the 1:2M scale model.

Since the TS segments in the 1:2M scale model contains 195 rows and since the latitudinal height of TS segments in all zones is constant at any given scale, the height of a 1:2M TS segment is equal to $180^\circ/195$, or 0.92307692° of latitude. The 1:2M scale model contains 304 columns in the temperate zones, and each column has constant width in degrees of longitude. Thus, the width of a 1:2M temperate zone segment is $360^\circ/304$, or 1.18421053° of longitude. Likewise, the 1:2M

scale model contains 380 columns of equal size in the equatorial zone. Thus, the width of a 1:2M equatorial zone segment is $360^\circ/380$, or 0.94736842° of longitude. Polar zone segments are equal in size to equatorial zone segments.

All other scale models differ from the 1:2M scale model in that the segment heights and widths are proportional to the ratio between the 1:2M scale's measurements and those of the scale of interest. For example, the segment height and widths for a 1:1M scale model are determined as follows:

$$\begin{aligned} \text{height (1:1M)} &= ((1/2,000,000)/(1/1,000,000)) \times \text{height (1:2M)} \\ &= 1/2 \times \text{height (1:2M)} \\ &= 1/2 \times 180^\circ/195 \\ &= 0.46153846^\circ \text{ latitude} \end{aligned}$$

$$\begin{aligned} \text{equatorial and polar width (1:1M)} &= ((1/2,000,000)/(1/1,000,000)) \times \text{equatorial width (1:2M)} \\ &= 1/2 \times \text{equatorial width (1:2M)} \\ &= 1/2 \times 360^\circ/380 \\ &= 0.47368421^\circ \text{ longitude} \end{aligned}$$

$$\begin{aligned} \text{temperate width (1:1M)} &= ((1/2,000,000)/(1/1,000,000)) \times \text{temperate width (1:2M)} \\ &= 1/2 \times \text{temperate width (1:2M)} \\ &= 1/2 \times 360^\circ/304 \\ &= 0.59210526^\circ \text{ longitude} \end{aligned}$$

Pixels

Each segment is subdivided into 256 rows and 256 columns. In the equatorial and temperate zones, each of these subdivisions is bounded by lines of constant latitude and longitude, and the latitudinal or longitudinal length of a subdivision is equal to $1/256$ times the segment's latitudinal or longitudinal length, respectively. This subdivision is the smallest entity in the TS model and is represented graphically as a pixel. More precisely, the pixel is the lower-left corner point of the subdivision, as shown in Fig. 7. Each pixel of CAC image data is assigned an RGB color value.

Given the segment sizes in Table 6, and the fact that a pixel is $1/256$ of a segment, then the size of a 1:2M pixel can be calculated as follows:

$$1:2M \text{ pixel height (all zones)} = 0.92307692^\circ/256 = 3.6 \times 10^{-3} \text{ degrees latitude}$$

$$\begin{aligned} 1:2M \text{ pixel width (polar \& equatorial zones)} \\ &= 0.94736842^\circ/256 = 3.7 \times 10^{-3} \text{ degrees longitude} \end{aligned}$$

$$\begin{aligned} 1:2M \text{ pixel width (temperate zones)} \\ &= 1.18421053^\circ/256 = 4.6 \times 10^{-3} \text{ degrees longitude} \end{aligned}$$

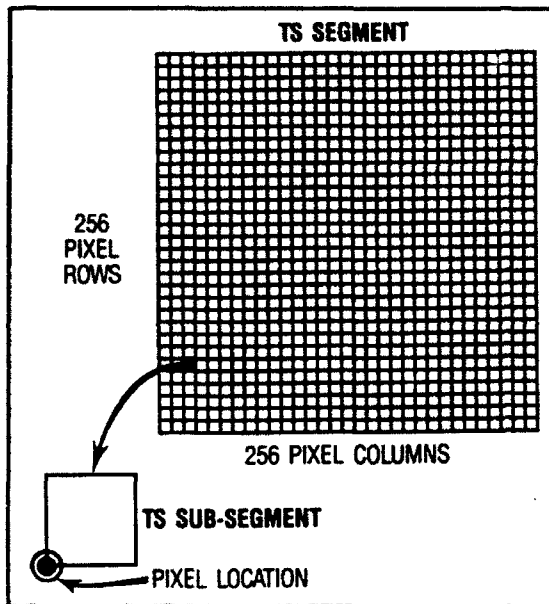

Fig. 7 — Pixel location within TS segment

Pixel sizes for other scales are directly proportional to the 1:2M pixel sizes (e.g., the longitudinal coverage of an equatorial pixel at the 1:1M scale is exactly one-half the longitudinal coverage of an equatorial pixel at the 1:2M scale).

The equivalent θ and λ values for any given pixel can be determined as follows:

Equatorial and (rotated) polar zone pixels (1:2M scale): $\theta = \theta^s + (\text{row}^P \times 3.7^\circ \times 10^{-3})$
 $\lambda = \lambda^s + (\text{column}^P \times 3.6^\circ \times 10^{-3})$

Temperate zone pixels (1:2M scale): $\theta = \theta^s + (\text{row}^P \times 4.6^\circ \times 10^{-3})$
 $\lambda = \lambda^s + (\text{column}^P \times 3.6^\circ \times 10^{-3})$

The coordinates of the south-west corner of the segment in which the pixel resides are θ^s and λ^s , and row^P and column^P are the row and column of the pixel within the segment, where $(\text{row}^P, \text{column}^P)$ of the lower-left pixel in a segment is (0, 0), and $(\text{row}^P, \text{column}^P)$ of the upper-right pixel in the segment is (255, 255).

Number of Rows of TS Segments

The number of rows of 1:2M segments in each zone, excluding overlap, are as follows (to include overlap, add four rows to each figure: two rows for the southern boundary overlap, and two rows for the northern boundary overlap):

$$\begin{aligned} \# \text{ rows of NP segments} &= (\text{upper NP boundary} - \text{lower NP boundary}) \times 2 / \text{segment height} \\ &= (90^\circ - 51.69230769^\circ) \times 2 / (180^\circ / 195) \\ &= 83 \end{aligned}$$

$$\begin{aligned} \# \text{ rows of NT segments} &= (\text{upper NT boundary} - \text{lower NT boundary})/\text{segment height} \\ &= (51.69230769^\circ - 31.38461538^\circ)/(180^\circ/195) \\ &= 22 \end{aligned}$$

$$\begin{aligned} \# \text{ rows of EQ segments} &= (\text{upper EQ boundary} - \text{lower EQ boundary})/\text{segment height} \\ &= (31.38461538^\circ - (-31.38461538^\circ))/(180^\circ/195) \\ &= 68 \end{aligned}$$

$$\begin{aligned} \# \text{ rows of ST segments} &= (\text{upper ST boundary} - \text{lower ST boundary})/\text{segment height} \\ &= (-31.38461538^\circ - (-51.69230769^\circ))/(180^\circ/195) \\ &= 22 \end{aligned}$$

$$\begin{aligned} \# \text{ rows of SP segments} &= (\text{upper SP boundary} - \text{lower SP boundary}) \times 2/\text{segment height} \\ &= (-51.69230769^\circ - (-90^\circ)) \times 2/(180^\circ/195) \\ &= 83 \end{aligned}$$

Rows of polar segments run parallel to the 90° E–90° W meridian. Since a rectangular grid cannot be evenly draped over a spherical surface, the number of polar segment rows is the number of EQ-sized segments that run along the 0°–180° meridian in each polar zone. Near the “edges” of the grid, far fewer segments will run in this direction, as Fig. 5 illustrates. The greatest number of segments exists in the row that crosses directly over the pole, along the 90° E–90° W meridian. Each polar zone overlaps its neighboring temperate zone by four segments (two at each zone boundary). Note, however, that the nature of the polar zones requires that the polar overlap area is not always along a row of polar segments. As an observer follows along the edge of a polar zone overlap region (for example, in Fig. 1), the point of overlap changes from being along a row (at 0° longitude) to being along a column (at 90° E longitude), then back along a row (at 180° longitude) and again along a column (at 90° W longitude). Each *nonpolar* zone overlap region is always parallel to a constant row of segments.

Number of Columns of TS Segments

The number of columns of TS segments in any nonpolar zone utilizes the circular radius defined from the axis of rotation of the earth at a so-called “central latitude” (CENT_LAT_Z). CENT_LAT_Z is zone-dependent, as indicated by the subscript Z, but it is independent of scale. CENT_LAT_Z is 14.123558° for the EQ zone and ±39.120799° for the NT and ST zones. At CENT_LAT_Z, the longitudinal extent of a segment corresponds exactly with a 51.04373385 mm (2.01 in.) wide portion of chart and the number of columns is calculated as follows:

$$\# \text{ columns}_Z = (\text{CIR}^{2M} \times \cos(\text{CENT_LAT}_Z))/51.04373385$$

Thus, the number of EQ, NT, and ST columns (at the 1:2M scale) may be derived as follows:

$$\begin{aligned} \# \text{ columns of 1:2M EQ segments} \\ = \text{NINT} [(20,001.21985 \times \cos (14.123558^\circ))/51.04373385] = 380 \end{aligned}$$

$$\begin{aligned} \# \text{ columns of 1:2M NT, ST segments} \\ = \text{NINT} [(20,001.21985 \times \cos (39.120799^\circ))/51.04373385] = 304, \end{aligned}$$

where NINT rounds to the nearest integer.

Like the latitudinal correction, a longitudinal screen factor correction is required to convert from data spacing in segments to the equal area display. The segments are resampled to the spacing of the display at the latitude of the display, and the resampling spacing is called the screen factor (SF_z). At a given latitude LAT in a given zone Z, the screen factor is calculated as follows:

$$SF_z = \cos (\text{CENT_LAT}_z) / \cos (\text{LAT}).$$

Due to the orientation of the polar zone, the number of columns of polar segments is calculated in the same way as the number of rows of polar segments, except that the segment width is used instead of segment height:

$$\begin{aligned} \# \text{ columns of NP segments} &= (\text{upper NP boundary} - \text{lower NP boundary}) \times 2 / \text{segment width} \\ &= (90^\circ - 51.69230769^\circ) \times 2 / (360^\circ / 380) \\ &= 80.87 \end{aligned}$$

$$\begin{aligned} \# \text{ columns of SP segments} &= (\text{upper SP boundary} - \text{lower SP boundary}) \times 2 / \text{segment width} \\ &= (-51.69230769^\circ - (-90^\circ)) \times 2 / (360^\circ / 380) \\ &= 80.87 \end{aligned}$$

Columns of polar segments run parallel to the 0° - 180° meridian. Again, since a rectangular grid cannot be evenly draped over a spherical surface, the number of polar segment columns is the number of EQ-sized segments that run along the 90° E- 90° W meridian in each polar zone. Near the "edges" of the grid, far fewer segments will run in this direction (Fig. 5). The greatest number of segments exists in the column that crosses over the pole.

Calculating TS Row and Column from Latitude and Longitude

Table 7 provides a partial list of the row boundaries (in degrees of latitude) for each nonpolar zone at a scale of 1:2M, and Table 8 provides a partial list of the column boundaries (in degrees of longitude) for these zones at the same scale. Table 9 provides a partial list of the segment corner points (in both polar and "rotated equatorial" latitude and longitude coordinates) for one-quarter of the north polar zone at a scale of 1:2M. The complete versions of these lists may be found in the appendix of the CAC Military Specification (Lohrenz 1991).

Table 7 — Partial List of Row Boundaries (Including Overlaps) for Nonpolar Zones at 1:2M Scale. Note that Each Upper Row Boundary is 1 Pixel Less than the Lower Boundary of the Next Row to the North.

Row	Boundaries (°lat)	
	Lower	Upper
<i>NT Zone (Rows 57 to 32):</i>		
57	52.61538462	53.53485577
56	51.69230769	52.61177885
-----Zone Overlap		
55	50.76923077	51.68870192
54	49.84615385	50.76562500
•	•	•
•	•	•
35	32.30769230	33.22716346
34	31.38461538	32.30408653
-----Zone Overlap		
33	30.46153846	31.38100961
32	29.53846154	30.45793269
<i>EQ Zone (Rows 35 to -36)</i>		
35	32.30769230	33.22716346
34	31.38461538	32.30408653
-----Zone Overlap		
33	30.46153846	31.38100961
32	29.53846154	30.45793269
•	•	•
•	•	•
0	0.00000000	0.91947115
•	•	•
•	•	•
-33	-30.46153846	-29.53485577
-34	-31.38461538	-30.45793269
-----Zone Overlap		
-35	-32.30769230	-31.38100961
-36	-33.23076923	-32.30408653
<i>ST Zone (Rows -33 to -58):</i>		
-33	-30.46153846	-29.53485577
-34	-31.38461538	-30.45793269
-----Zone Overlap		
-35	-32.30769230	-31.38100961
-36	-33.23076923	-32.30408653
•	•	•
•	•	•
-55	-50.76923077	-49.84254808
-56	-51.69230769	-50.76562500
-----Zone Overlap		
-57	-52.61538462	-51.68870192
-58	-53.53846154	-52.61177885

Table 8 — Partial List of Column Boundaries for Nonpolar Zones at 1:2M Scale. Note that Each Eastern Column Boundary is 1 Pixel Less than the Western Boundary of the Next Column to the East.

Column	Boundaries (°lon)		Column	Boundaries (°lon)	
	West	East		West	East
<i>NT and ST Zones (Columns -152 to 151):</i>			<i>EQ Zone (Columns -190 to 189):</i>		
-152	-180.00000000	-178.81116361	-190	-180.00000000	-179.04893091
-151	-178.81578943	-177.62695308	-189	-179.05263157	-178.10156249
-150	-177.63157890	-176.44274255	-188	-178.10526315	-177.15419407
.
.
0	0.00000000	1.17958471	0	0.00000000	0.94366776
.
.
149	176.44736837	177.62695308	187	177.15789473	178.10156249
150	177.63157890	178.81116361	188	178.10526315	179.04893091
151	178.81578943	179.99537418	189	179.05263157	179.99629934

The following equations calculate the TS row and column numbers for a given nonpolar latitude and longitude coordinate (variables and functions are defined following the equations):

$$f_ROW = (LAT \times FACTOR) / (180.0 / NTESS^R)$$

$$ROW = TRUNC (f_ROW)$$

$$f_COL = (LON \times FACTOR) / (360.0 / NTESS^C)$$

$$COL = TRUNC (f_COL)$$

To handle row or column rounding and truncation errors, make the following checks and corrections:

Negative latitude case: If $ROW < 0$ and $|ROW - f_ROW| \geq PIX_HT/2$, then $ROW = ROW - 1$

Positive latitude case: If $ROW > 0$ and $|ROW - f_ROW| < PIX_HT/2$, then $ROW = ROW + 1$

Negative longitude case: If $COL < 0$ and $|COL - f_COL| \geq PIX_WD/2$, then $COL = COL - 1$

Positive longitude case: If $COL > 0$ and $|COL - f_COL| < PIX_WD/2$, then $COL = COL + 1$

Special cases: If $COL \geq NTESS^C \times FACTOR/2$, then $COL = COL - (NTESS^C \times FACTOR)$

If $COL < -NTESS^C \times FACTOR/2$, then $COL = COL + (NTESS^C \times FACTOR)$

Table 9 — Partial List of Segment Corner Points (in Both Polar and "Rotated Equatorial" Latitude and Longitude Coordinates) for One-Fourth of the North Polar (NP) Zone at 1:2M Scale

ROW 0	EQ LAT	EQ LON	NP LAT	NP LON
	0.00000000	180.00000000	90.00000000	90.00000000
	0.00000000	179.05263158	89.05263158	90.00000000
	0.00000000	178.10526316	88.10526316	90.00000000

	.	(Total of 43 Segments in Row 0)	.	.

	0.00000000	142.10526316	52.10526316	90.00000000
	0.00000000	141.15789474	51.15789474	90.00000000
	0.00000000	140.21052632	50.21052632	90.00000000
ROW 1	EQ LAT	EQ LON	NP LAT	NP LON
	0.92307692	180.00000000	89.07697898	0.00000000
	0.92307692	179.05263158	88.67735224	45.74027634
	0.92307692	178.10526316	87.89246947	64.01953888

	.	(Total of 43 Segments in Row 1)	.	.

	0.92307692	142.10526316	52.09571213	88.49735260
	0.92307692	141.15789474	51.14866271	88.52839661
	0.92307692	140.21052632	50.20160046	88.55780029
.
.
.
.
ROW 42	EQ LAT	EQ LON	NP LAT	NP LON
	38.76923077	180.00000000	51.23076897	0.00000000
	38.76923077	179.05263158	51.22101818	1.17936492
	38.76923077	178.10526316	51.19178086	2.35740948

	.	(Total of 13 Segments in Row 42)	.	.

	38.76923077	170.52631579	50.26781440	11.58180809
	38.76923077	169.57894737	50.06861610	12.69224834
	38.76923077	168.63157895	49.85160910	13.78975296
ROW 43	EQ LAT	EQ LON	NP LAT	NP LON
	39.69230769	180.00000000	50.30769125	0.00000000
	39.69230769	179.05263158	50.29825586	1.14121962
	39.69230769	178.10526316	50.26996350	2.28122282
	39.69230769	177.15789474	50.22285546	3.41880035
	39.69230769	176.21052632	50.15700025	4.55275583
	39.69230769	175.26315790	50.07249310	5.68191433
	39.69230769	174.31578947	49.96945530	6.80512571
	39.69230769	173.36842105	49.84803339	7.92127323

Variables are defined as follows:

ROW, COL	Integer row and column number of the TS segment
f_ROW, f_COL	Floating point versions of ROW and COL
LAT, LON	Latitude and Longitude of the SW corner of the TS segment
FACTOR	Scaling factor, which is calculated as $(2,000,000/(\text{inverse of scale}))$: FACTOR = 1 for 1:2M scale FACTOR = 2 for 1:1M scale FACTOR = 4 for 1:500k scale FACTOR = 8 for 1:250k scale FACTOR = 20 for 1:100k scale FACTOR = 40 for 1:50k scale
NTESS ^R	Number of row-based tessellations per 180° of latitude in the 1:2M scale model: NTESS ^R = 195 for all zones
NTESS ^C	Number of column-based tessellations per 360° of longitude in the 1:2M scale model: NTESS ^C = 380 for Equatorial and Polar zones NTESS ^C = 304 for Temperate zones
PIX_HT, PIX_WD	Height and width of a pixel at a given zone and scale (1/256 of the segment height or width, respectively, as defined in an earlier section of this report)
TRUNC	Function to truncate floating point number to integer; e.g.: TRUNC (38.7) = 38, and TRUNC (-26.5) = -26
x	Absolute value of x; e.g., 2 = 2, and -2 = 2

To calculate row and column numbers from a polar latitude and longitude, first rotate the polar coordinates to equatorial coordinates (the rotation equations are given in the "TS Polar Rotations" section). Then, convert the rotated equatorial coordinates (LAT, LON) to TS ROW, COL as shown above for nonpolar data.

Calculating Latitude and Longitude Coordinates for TS Segment at Given Row and Column Location

The following equations calculate the latitude and longitude of the southwest corner of a nonpolar TS segment that is located at a given row and column:

$$\text{LAT} = (\text{float}(\text{ROW}) \times (180.0/\text{NTESS}^R))/\text{FACTOR}$$

$$\text{LON} = (\text{COL} \times (360.0/\text{NTESS}^C))/\text{FACTOR}$$

Variables are defined in the previous section. To calculate the polar latitude and longitude of a TS row and column number, first use the above equations to calculate the rotated equatorial latitude and longitude (LAT and LON) from ROW and COL. Then rotate LAT and LON to the polar coordinates using the rotation equations given in the following section of this report.

TS POLAR ROTATIONS

Rotation from Polar Coordinates to Equatorial Coordinates

Given a pair of polar zone coordinates (θ^P , λ^P), the rotated coordinates (θ^R , λ^R) of the corresponding point in the equatorial zone are as follows:

$$\theta^R = \begin{cases} \arcsin [\cos(\theta^P) \times \cos(\lambda^P)] & \text{for } \theta^P \neq 90^\circ \\ 0^\circ & \text{for } \theta^P = 90^\circ \end{cases}$$

$$\text{North Polar: } \lambda^R = \begin{cases} \arctan \left[\frac{-\cos(\theta^P) \times \sin(\lambda^P)}{\sin(\theta^P)} \right] + 180^\circ & \text{for } \theta^P \neq 90^\circ \\ 180^\circ & \text{for } \theta^P = 90^\circ \end{cases}$$

$$\text{South Polar: } \lambda^R = \begin{cases} \arctan \left[\frac{-\cos(\theta^P) \times \sin(\lambda^P)}{\sin(\theta^P)} \right] & \text{for } \theta^P \neq 90^\circ \\ 180^\circ & \text{for } \theta^P = 90^\circ \end{cases}$$

Figure 8 illustrates this transformation for both poles. One more equation is included for completeness, although it is not applicable here (since the polar zone only extends from $\pm 90^\circ$ to $\pm 51.7^\circ$ in latitude):

$$\text{Special Case: if } \theta^P = 0^\circ \text{ then } \lambda^R = \begin{cases} -90^\circ & \text{for } \lambda^P < 0^\circ \\ 90^\circ & \text{for } \lambda^P \geq 0^\circ \end{cases}$$

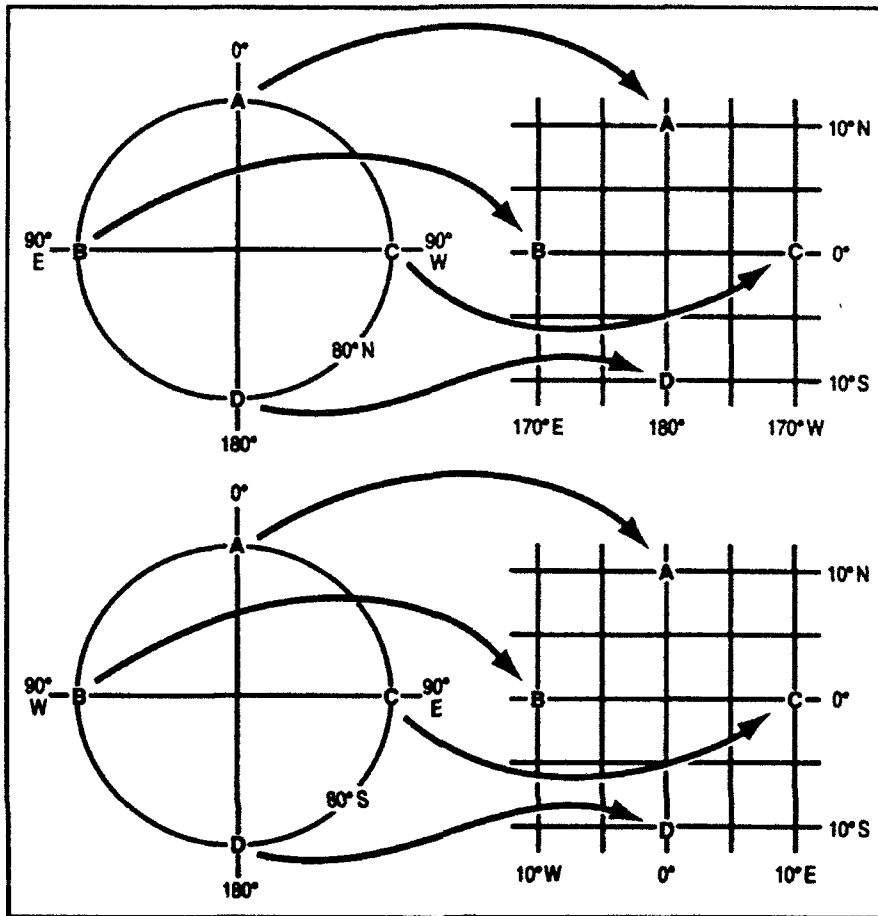

Fig. 8 — Transformation from polar zone to equatorial coordinates

Rotation from Equatorial Coordinates to Polar Coordinates

Given a pair of rotated equatorial zone coordinates (θ^R, λ^R) , the coordinates (θ^P, λ^P) of the corresponding point in the polar zone are as follows:

North Polar: $\theta^P = \arcsin [\cos (\theta^R) \times \cos (\lambda^R - 180^\circ)]$

$$\lambda^P = \begin{cases} \arctan \left[\frac{\cos(\theta^R) \times \sin(\lambda^R)}{\sin(\theta^R)} \right] & \text{for } \theta^R > 0^\circ \\ \arctan \left[\frac{\cos(\theta^R) \times \sin(\lambda^R)}{\sin(\theta^R)} \right] + 180^\circ & \text{for } \theta^R < 0^\circ \\ -90^\circ & \text{for } (\theta^R = 0^\circ, \lambda^R > 180^\circ) \\ 90^\circ & \text{for } (\theta^R = 0^\circ, \lambda^R \leq 180^\circ) \end{cases}$$

$$\text{South Polar: } \theta^P = \arcsin [-\cos (\theta^R) \times \cos (\lambda^R)]$$

$$\lambda^P = \begin{cases} \arctan \left[\frac{\cos(\theta^R) \times \sin(\lambda^R)}{\sin(\theta^R)} \right] & \text{for } \theta^R > 0^\circ \\ \arctan \left[\frac{\cos(\theta^R) \times \sin(\lambda^R)}{\sin(\theta^R)} \right] + 180^\circ & \text{for } \theta^R < 0^\circ \\ 90^\circ & \text{for } (\theta^R = 0^\circ, \lambda^R \geq 0^\circ) \\ -90^\circ & \text{for } (\theta^R = 0^\circ, \lambda^R < 0^\circ) \end{cases}$$

DOWNSAMPLING FROM ARC TO TS

Downsampling data from the ARC model into TS reduces the image resolution by approximately 50%: from 10 to approximately 5 pixels per linear millimeter (precisely 254 to 128 ppi). Conversely, downsampling increases the nominal pixel spacing from 100 μm to approximately 200 μm , in both the east-west and north-south directions. Thus, the amount of storage that is required to store a given section of chart data is reduced by a factor of approximately 4:1 (2:1 in the X direction, and 2:1 in the Y). After this transformation, one segment (256 \times 256 pixels) of TS data consists of 196,608 bytes; prior to the conversion from ARC to TS, an equivalent section of map data consisted of more than 780,000 bytes.

Map data are downsampled from ARC to TS with a neighborhood averaging function. If the TS pixel grid is "overlaid" onto the ARC grid, there would usually be four neighboring ARC pixels for each TS pixel. (An exception may occur at the edge of an area, in which case there might be less than four neighboring ARC pixels). As shown in Fig. 9, typically four ARC pixels (A1, A2,

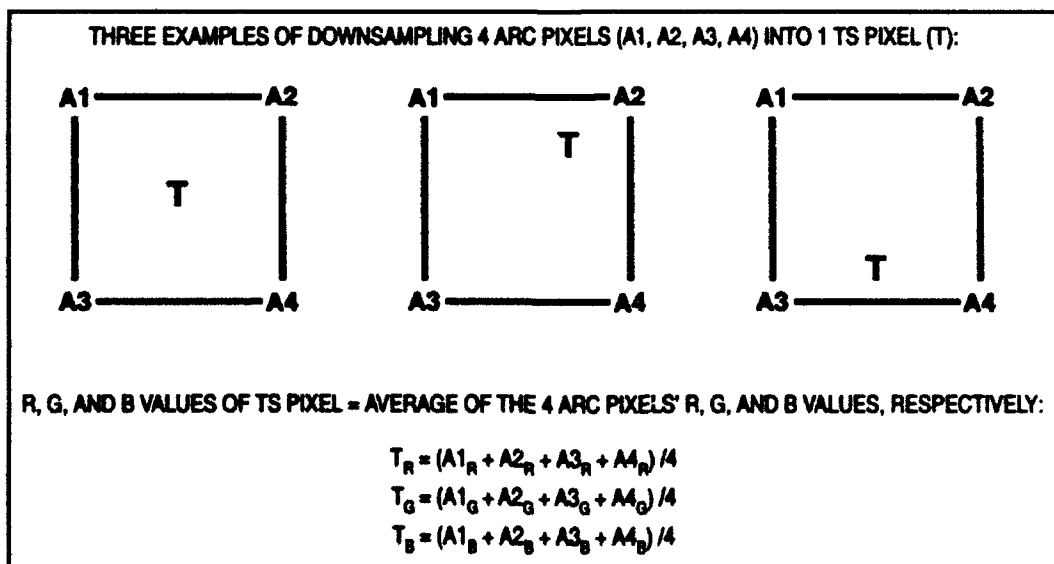

Fig. 9 — Downsampling four ARC pixels into one TS pixel

A3, and A4) define a box around the TS pixel (T), but T is not necessarily in the exact center of this box. To assign an appropriate RGB value to T, the red, green, and blue components of each of the neighboring ARC pixels are averaged, as shown in the equations at the bottom of Fig. 9. A more general equation for this operation is as follows:

$$T_c = \frac{1}{N} \sum_{n=1}^N A_n c$$

where N = number of ARC pixels (up to 4) that neighbor the TS pixel and c = color component (R, G, or B)

No consideration is given to the distance between the TS pixel and each of the ARC pixels in this function. We investigated the effects of incorporating a distance factor into the equation, so that the RGB value of an ARC pixel that is closer to the output TS pixel would be weighted more heavily than the RGB value of an ARC pixel that was farther away. However, no improvement was observed in the quality of the output image, and the algorithm's execution speed was somewhat degraded, so the weight factor was not included in the final algorithm. A follow-up report will present this downsampling process in greater detail.

TS PROJECTION DISTORTION

While there is little, if any, observable distortion of CAC features in the TS projection, slight distortion does occur during the equirectangular projection and display of CAC data from scene memory. The least amount of distortion exists at the center of a given display of data (in the digital moving map systems, that is at the center of a 127 mm² (5 in.²) section of displayed chart data), and distortion increases in the east-west direction as the edges of the current display are approached. The variation in pixel spacing causes the distortion to accumulate from the meridian that passes

through the center of the display. The amount of distortion is greatest in the smallest scales (i.e., worst in the 1:2M scale) due to the greater geographic coverage per display. Figure 10 illustrates the distribution of projection distortion for a 127 mm × 127 mm display in a north-up orientation. The greatest distortion at any given scale occurs at each of the four corners of the display.

The maximum possible distortion in the TS model occurs at the points at which the latitude is farthest from the equator (i.e., at the edge of the temperate zones' pole-most overlap regions) and, as previously mentioned, at the largest display coverage (i.e., the smallest scale, which is 1:2M). Table 10 gives the maximum distortion for each nonpolar TS zone at

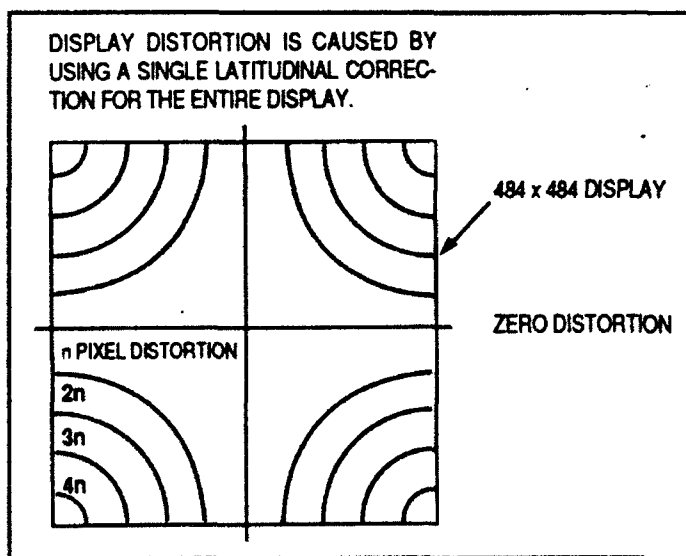

Fig. 10 — Distribution of projection distortion

Table 10 — Worst-Case Distortions (in Overlap Segments) for Nonpolar TS Zones

Map Scale	Latitude (degrees)	Display Distortions (pixels)	Coverage Distortions (meters)	Coverage Distortions (nmi)
<i>Equatorial Zone</i>				
1:50,000	±31.431	$\pm 5.5691 \times 10^{-2}$	$\pm 5.5256 \times 10^{-1}$	$\pm 2.9836 \times 10^{-4}$
1:100,000	±31.477	$\pm 1.1149 \times 10^{-1}$	±2.2124	$\pm 1.1946 \times 10^{-3}$
1:250,000	±31.615	$\pm 2.7956 \times 10^{-1}$	$\pm 1.3869 \times 10^1$	$\pm 7.4885 \times 10^{-3}$
1:500,000	±31.846	$\pm 5.6186 \times 10^{-1}$	$\pm 5.5747 \times 10^1$	$\pm 3.0101 \times 10^{-2}$
1:1,000,000	±32.308	±1.1347	$\pm 2.2516 \times 10^2$	$\pm 1.2158 \times 10^{-1}$
1:2,000,000	±33.231	±2.3129	$\pm 9.1795 \times 10^2$	$\pm 4.9565 \times 10^{-1}$
<i>Temperate Zones</i>				
1:50,000	±51.738	$\pm 1.0484 \times 10^{-1}$	±1.0402	$\pm 5.6166 \times 10^{-4}$
1:100,000	±51.785	$\pm 2.0978 \times 10^{-1}$	±4.1628	$\pm 2.2477 \times 10^{-3}$
1:250,000	±51.923	$\pm 5.2519 \times 10^{-1}$	$\pm 2.6054 \times 10^1$	$\pm 1.4068 \times 10^{-2}$
1:500,000	±52.154	±1.0529	$\pm 1.0446 \times 10^2$	$\pm 5.6406 \times 10^{-2}$
1:1,000,000	±52.615	±2.1156	$\pm 4.1982 \times 10^2$	$\pm 2.2668 \times 10^{-1}$
1:2,000,000	±53.538	±4.2703	$\pm 1.6948 \times 10^3$	$\pm 9.1510 \times 10^{-1}$

Table 11 — Worst-Case Distortions (in Overlap Segments) for Polar TS Zones

Map Scale	Polar Latitude (degrees)	Rotated Equatorial Latitude (degrees)	Display Distortions (pixels)	Coverage Distortions (meters)	Coverage Distortions (nmi)
1:50,000	±51.646	±38.354	$\pm 6.6275 \times 10^{-2}$	$\pm 6.5757 \times 10^{-1}$	$\pm 3.5506 \times 10^{-4}$
1:100,000	±51.600	±38.400	$\pm 1.3265 \times 10^{-1}$	±2.6323	$\pm 1.4213 \times 10^{-3}$
1:250,000	±51.462	±38.538	$\pm 3.3238 \times 10^{-1}$	$\pm 1.6489 \times 10^1$	$\pm 8.9036 \times 10^{-3}$
1:500,000	±51.231	±38.769	$\pm 6.6729 \times 10^{-1}$	$\pm 6.6208 \times 10^1$	$\pm 3.5749 \times 10^{-2}$
1:1,000,000	±50.769	±39.231	±1.3446	$\pm 2.6683 \times 10^2$	$\pm 1.4407 \times 10^{-1}$
1:2,000,000	±49.846	±40.154	±2.7292	$\pm 1.0831 \times 10^3$	$\pm 5.8485 \times 10^{-1}$

each display scale; Table 11 gives the maximum distortion for the polar zones at each scale. The derivation for these distortion values is illustrated in Figs. 11 and 12, and the necessary variables and constants are defined in Table 12. Figure 11a provides a partial model of a sphere, and the equations that yield the precise width (before display) of a segment at a given latitude in the equatorial zone at a scale of 1:2M. Figure 11b provides a similar model for the polar zone. Polar

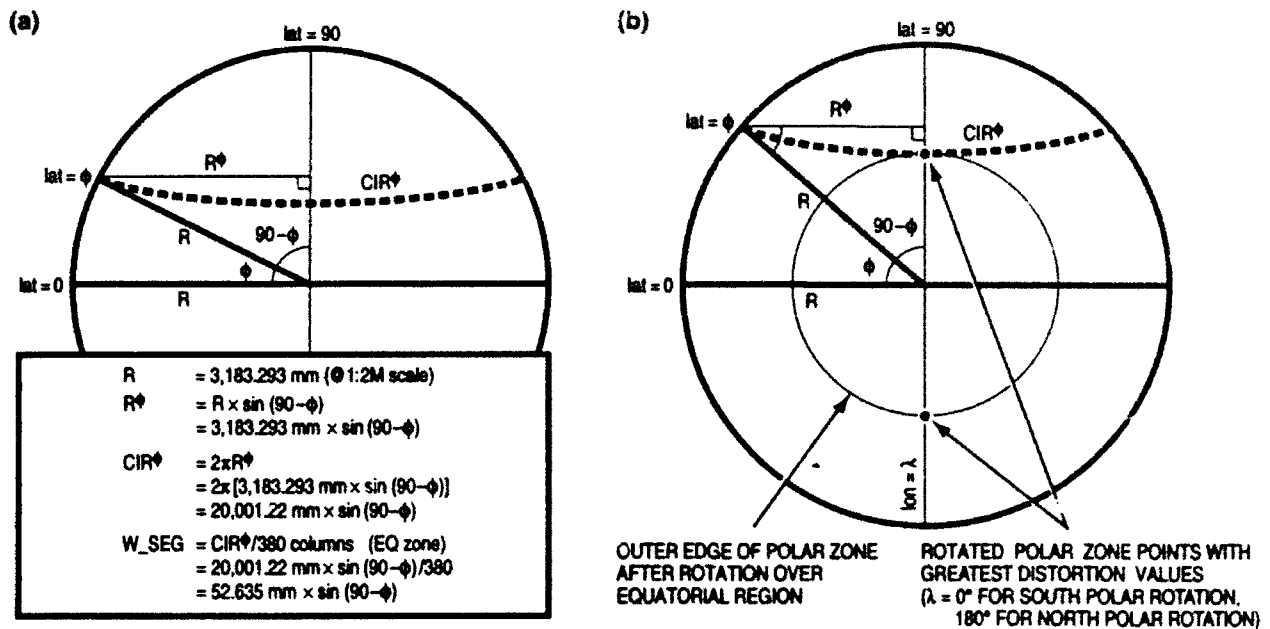

Fig. 11 — TS projection distortion models: (a) nonpolar zones; (b) polar zones.

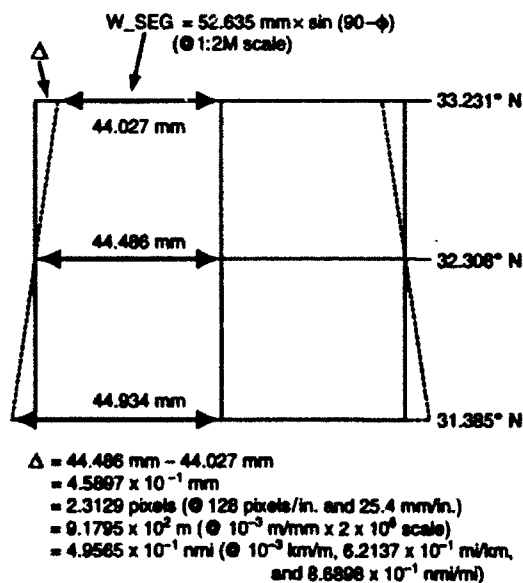

Fig. 12 — Display distortion (exaggerated) of four TS segments (1:2M scale, EQ zone).

Table 12 — Parameters Required in Calculating Distortion for the TS Model

R	= Radius of earth at the equator, at 1:2M scale = 3,183.293006 mm
R^ϕ	= Radius of earth at latitude ϕ , at 1:2M scale = $R \times \sin(90 - \phi)$
CIR^ϕ	= Circumference of earth at latitude ϕ , at 1:2M scale = $2\pi \times R^\phi$ = $2 \times 3.1416 \times 3,183.293006 \text{ mm} \times \sin(90 - \phi)$ = $20,001.21985 \text{ mm} \times \sin(90 - \phi)$
NCOL	= Number of TS columns at 1:2M scale = 380 for EQ, NP, and SP zones = 304 for NT and ST zones
SCALE	= Inverse of the data scale (e.g., if data scale is 1:50,000, then SCALE = 50,000).
SEG_HT	= Height of 1 segment ($^\circ$ latitude); constant for all zones within a scale, but scale-dependent.
MIN_LAT	= For polar zones only: Polar zone latitude that is farthest from the pole.
MAX_LAT	= Nonpolar zones: Latitude that is farthest from the equator in the given zone. Polar zones: Rotated equatorial equivalent of polar MIN_LAT latitude at 0° longitude.
W_SEG1	= Width (in mm, at 1:2M scale) of the edge of a segment at MAX_LAT. In the model that is used for maximum distortion calculations, this is the top edge of the display: = $CIR^{\text{MAX_LAT}}/\text{NCOL}$ <i>For EQ, NP, and SP zones:</i> = $[20,001.21985 \text{ mm} \times \sin[(90 - \text{MAX_LAT})]/380$ = $52.63478908 \text{ mm} \times \sin(90 - \text{MAX_LAT})$ <i>For NT and ST zones:</i> = $[20,001.21985 \text{ mm} \times \sin(90 - \text{MAX_LAT})]/304$ = $65.79345635 \text{ mm} \times \sin(90 - \text{MAX_LAT})$
W_SEG2	= Width (in millimeters, at 1:2M scale) of the edge of a segment that is 1 segment lower than MAX_LAT. In the model that is used for maximum distortion calculations, this is the center of the display: = $CIR^{(\text{MAX_LAT}-\text{SEG_HT})}/\text{NCOL}$ <i>For EQ, NP, and SP zones:</i> = $(20,001.21985 \text{ mm} \times \sin[90 - (\text{MAX_LAT}-\text{SEG_HT})])/380$ = $52.63478908 \text{ mm} \times \sin[90 - (\text{MAX_LAT}-\text{SEG_HT})]$ <i>For NT and ST zones:</i> = $(20,001.21985 \text{ mm} \times \sin[90 - (\text{MAX_LAT}-\text{SEG_HT})])/304$ = $65.79348635 \text{ mm} \times \sin[90 - (\text{MAX_LAT}-\text{SEG_HT})]$
Δ^{mm}	= Maximum display distortion (at 1:2M scale) in millimeters: = $ W_SEG1 - W_SEG2 $
Δ^{P}	= Maximum display distortion in pixels (@ exactly 128 pixels/in. and 25.4 mm/in.): = $\Delta^{\text{mm}} \times 5.03937008 \text{ pixels/mm}$
Δ^{m}	= Maximum coverage distortion (converted to "real world" 1:1 scale) in meters: = $\Delta^{\text{mm}} \times \text{SCALE} \times 0.001 \text{ m/mm}$
Δ^{n}	= Maximum coverage distortion in nautical miles: = $\Delta^{\text{m}} \times (1 \text{ km}/1000 \text{ m}) \times (1 \text{ mi}/1.609344 \text{ km}) \times (0.86897624 \text{ nmi/mi})$ = $\Delta^{\text{m}} \times 0.00053996 \text{ nmi/m}$

zone distortions were calculated from the rotated equatorial coordinates of the points that are farthest from the equator on the rotated equatorial grid (i.e., at the edge of the overlap region and lying on the 0°-180° meridian). Figure 12 illustrates the distortion of four TS segments: the dashed lines indicate how the segments would appear if there were no distortion, and the solid lines indicate how the segments are actually displayed. (Note that this figure significantly exaggerates the distortion in order to illustrate its effect). The maximum display distortion Δ is calculated as the difference between the ideal segment width (which is the width of the segment at the center of the display) and the predistorted width of the segment at the edge of the display. Figure 12 presents the distortion (in display millimeters, pixels, and nautical miles on the Earth) for a segment at the edge of the equatorial zone at a scale of 1:2M. The illustrated distortion values in pixels, meters, and nautical miles correspond to the distortion values in Table 10 for this zone and scale.

APPLYING TS TO DATABASES OTHER THAN CAC

The TS projection system was originally designed to store CAC data around the globe in a seamless manner for use in aircraft mission planning systems and digital moving map systems. However, the presentation of the CAC data in TS, along with the efficient compression strategy that is used, has piqued the interest of several potential users of other databases. Two in particular are a proposed Compressed Nautical Chart (CNC) database and a compressed version of the DMA Digital Land Mass System (DLMS) database. The CNC would be identical to the CAC, except that the data would consist of nautical charts instead of aeronautical charts. The primary concern for such a database would be scale: the maximum scale required for nautical chart data is, logically, considerably larger than the maximum scale that is required for aeronautical chart data. DMA plans to provide the uncompressed nautical chart data in the form of ADRG, and NRL has proposed to transform this nautical ADRG data into TS and compress it in exactly the same way that CAC is processed now.

The compression of DLMS would be completely different from the CAC and CNC compressions, since DLMS is fundamentally different from ADRG. DLMS is a union of Digital Terrain Elevation Data (DTED) and Digital Feature Analysis Data (DFAD). DTED consists of elevation posts that are equally spaced in latitude and longitude. DFAD is a list of point, linear, and areal features that are stored as single points, vectors, and polygons. Neither dataset is stored in any specific map projection, so the "transformation" of DLMS to TS merely consists of splitting the data into discrete TS segments, according to their latitude and longitude positions. The scale of DLMS is determined by the DTED post-spacing and is considered to be closest to the 1:250k TS scale model.

The following sections will discuss several issues that must be addressed before TS can be applied as a standard projection and display system for databases other than CAC. All of these issues are associated with scale.

Distortion Due to Scale Incompatibility

The TS model is currently configured to handle any scale that can be integrally divided by 1:2M (the base scale for the TS projection system). For example, nautical chart data at an original scale of 1:7091 would have to be resampled into a 1:8k scale model before it could be considered compatible with the TS model (8,000 is the closest number to 7091 that can be integrally divided into 2,000,000).

Such resampling is not a major problem for chart data that will be converted to a scale relatively close to the original chart scale, but some distortion problems could result from resampling data to a scale that is not reasonably similar to the original. For example, when data are resampled to a smaller scale (e.g., from 1:7091 to 1:8000), each pixel in the dataset is forced to represent a larger area (in this case, each resampled pixel must represent an area that is approximately 1.13 times larger than the area that was represented by the original pixel). Likewise, when data are resampled to a larger scale (for example, from 1:8652 to 1:8000), each pixel in the resampled dataset will represent a smaller area than a pixel in the original dataset (in the given example, each resampled pixel would represent an area that is approximately 0.92 times the size of the original pixel). In either case, some distortion can be expected in the geographic integrity of the resampled dataset, and the amount of distortion would be directly proportional to the degree of resampling that must be done.

TS Segment Row Limits

TS segment filenames are derived from the segment's row and column values and the TS zone in which it resides. As described here, the maximum number of rows (covering the earth ellipsoid) supported by the TS model is 9000, and there are 195 rows of TS segments at the 1:2M base scale. The number of rows in any other scale is directly proportional to the ratio of the base scale to the scale in question. For example, the 1:1M scale has twice as many rows as the 1:2M scale. Thus, the largest scale that can be supported in the current TS model can be calculated as follows:

$$\text{largest_scale} = 2,000,000 \times (195/9000) = 43,333.33$$

Since the scale in question must also be an integral divisor of the base scale (which 1:43,333 is not) the largest scale that is currently supported by the TS model is 1:50k.

However, CNC data will include nautical charts at scales as large as 1:8k. Several methods are being investigated that would allow these larger scales to be represented in the TS model without having to significantly modify the specification for TS or for the CAC/CNC products. For example, the segment filenames could be encoded in other than base¹⁰ for scales larger than 1:50k. Hex (base¹⁶) numbers, base²⁶ (which would use the letters A through Z instead of numerals 0 through 9), or base³⁶ (which would use the numerals 0 through 9 and letters A through Z) are all being considered for scales larger than 1:50k. Base¹⁰ would be maintained for scales smaller than 1:50k, so that existing systems that use the CAC database (but which do not plan to use the CNC database) would not be affected. Systems that do plan to use CNC would have to include a check for scale, and then decode the filenames according to the appropriate base system. A future report will identify which base is chosen for these larger scales.

CONCLUSIONS AND RECOMMENDATIONS

The TS model (formerly referred to as TS Model IV, or TS-4) provides a seamless, global framework in which to store scanned chart data and, potentially, other data types as well. TS sections the data into latitudinally based zones and then subdivides the zones into tessellations, or segments, of 256 × 256 pixels. The TS model was originally conceived for the CAC database, which includes six scale models of chart data that range from 1:50k to 1:2M. All TS parameters are based on the 1:2M scale model, and any additional scales that are to utilize TS must be an

integral divisor of 2,000,000. In addition, the TS model currently stipulates that segment filenames are dependent on a maximum of 9000 TS segment rows; however, scales that are larger than approximately 1:50k have more than 9000 rows. These restrictions do not necessarily prohibit additional scales from being included in the TS model, but they must be resolved before any new scales are added. Several potential solutions, such as the utilization of some base other than base¹⁰ to encode the segment filenames, were suggested. A future report will identify the base chosen for these larger scales. Another follow-up report will present the downsampling process (interpolation of TS pixels from ARC) in greater detail.

ACKNOWLEDGMENTS

This work was funded by the Naval Air Systems Command (NAVAIR) AV-8B, F/A-18, V-22, and A-X programs (program elements 0604214N, APN, 0604262N, and 0604233N). The authors thank the program managers at NAVAIR for supporting of this project: Major A. Nalls (AV-8B); CDR J. V. Chenevy, LCDR C. Cleaver, and Major J. P. Stevens (F/A-18); CDR M. Redshaw (V-22); and LCDR J. Wieringa (A-X). We also thank Mary Clawson, the NRL liaison at CNO (N096), for her technical review of this document, and Mr. Ed Ronish (Honeywell, Inc.) for his guidance.

REFERENCES

- Beyer, W. H., *CRC Standard Mathematical Tables, 25th Edition*. (CRC Press, Inc., Boca Raton, FL, 1979).
- Defense Mapping Agency, "Product Specifications for ARC Digitized Raster Graphics (ADRG)," 1st ed., DMA Report PS/2DJ/100, April 1989.
- Honeywell, Inc., "Method of Storage and Retrieval of Digital Map Data Based Upon a Tessellated Geoid System," Honeywell, Inc., Albuquerque, NM. U.S. Patent 4,899,293, February 1990.
- Lohrenz, M. C., "Military Specification: The Navy Standard Compressed Aeronautical Chart (CAC)," 1991.
- "Database (MIL-C-89016)," Naval Research Laboratory, Stennis Space Center, MS, NRL Special Project 024:351:91, August.
- Lohrenz, M. C., H. Rosche, and M. E. Trenchard, "Compression of Scanned Aeronautical Chart Data in Support of Naval Aircraft Digital Moving Map Systems," presented at IEEE Data Compression Conference, Navy session, Snowbird, UT, April 1991.
- Lohrenz, M. C. and J. E. Ryan, "The Navy Standard Compressed Aeronautical Chart Database," Naval Research Laboratory, Stennis Space Center, MS, NOARL Report 8, July 1990.
- Ronish, E., "Engineering Bulletin for Interface Control Document for the Sperry Ground Support Station," Honeywell, Inc., Albuquerque, NM, Honeywell Report Number GSS-DMC-8601, Appendix I, 1986.