

# AD-A270 627



## TION PAGE

Form Approved  
OMB No. 0704-0188

22

average 1 hour per response, including the time for reviewing instructions, searching existing data sources, the collection of information. Send comments regarding this burden estimate or any other aspect of this Washington Headquarters Services, Directorate for Information Operations and Reports, 1215 Jefferson Management and Budget, Paperwork Reduction Project (0704-0188), Washington, DC 20503.

1. AGENCY USE ONLY (Leave blank)	2. REPORT DATE 30 September 93	3. REPORT TYPE AND DATES COVERED Final Report 1 Apr 93-30 Sept 93
----------------------------------	-----------------------------------	--

4. TITLE AND SUBTITLE Four-Dimensional Remote Sensing of the Marine Boundary Layer with a Digital Beamforming Radar Wind Profiler	5. FUNDING NUMBERS C: N00014-93-C-0042
6. AUTHOR(S) James B. Mead	

7. PERFORMING ORGANIZATION NAME(S) AND ADDRESS(ES) Quadrant Engineering, Inc. 31 Campus Plaza Road Hadley, MA 01035	8. PERFORMING ORGANIZATION REPORT NUMBER Q930010
--	---

9. SPONSORING/MONITORING AGENCY NAME(S) AND ADDRESS(ES) Office of Naval Research 800 N. Quincy Street Ballston Tower One Arlington, VA 22217-5660	10. SPONSORING/MONITORING AGENCY REPORT NUMBER
---	--

007 0 3 1993

11. SUPPLEMENTARY NOTES
-------------------------

12a. DISTRIBUTION / AVAILABILITY STATEMENT Approved for public release; SBIR report, distribution unlimited.	12b. DISTRIBUTION CODE
---	------------------------

13. ABSTRACT (Maximum 200 words)  
This report details research performed by Quadrant Engineering under ONR SBIR contract no. N00014-93-C-0042. The purpose of this study was to determine the feasibility of deploying a shipboard turbulent eddy profiling (TEP) radar system for studying the dynamics of the marine boundary layer. A similar system is currently being developed by the University of Massachusetts to study the atmospheric boundary over land. During the phase I study, Quadrant Engineering reviewed the design of the land based system, and determined that a slightly scaled down version of that system would be suitable for deployment on a large research vessel, such as the Knorr, operated by Woods Hole Oceanographic Institute. In this report, we present a design for the shipboard TEP system and consider the particular requirements of installation on the Knorr. We also describe the application of TEP to boundary layer research, especially in terms of complimenting Large Eddy Simulation (LES) models.

14. SUBJECT TERMS Radar wind profiler, marine boundary layer, turbulence, coherent structures	15. NUMBER OF PAGES 31
	16. PRICE CODE

17. SECURITY CLASSIFICATION OF REPORT unclassified	18. SECURITY CLASSIFICATION OF THIS PAGE unclassified	19. SECURITY CLASSIFICATION OF ABSTRACT unclassified	20. LIMITATION OF ABSTRACT U1
---	--	---	----------------------------------

NSN 7540-01-280-5500

Standard Form 298 (Rev 2-89)  
Prescribed by ANSI Std. Z39-18  
298-102

REF 9

# 93 10 5 0 31

93-23258  
3291

# **Four-Dimensional Remote Sensing of the Marine Boundary Layer with a Digital Beamforming Radar Wind Profiler**

James B. Mead

Quadrant Engineering, Inc.

1993

**ONR**

Office of Naval Research

# **Four-Dimensional Remote Sensing of the Marine Boundary Layer with a Digital Beamforming Radar Wind Profiler**

Prepared by

James B. Mead., Principal Investigator

Quadrant Engineering, Inc.

31 Campus Plaza Road

Hadley, MA 01035

September 1993

**Contract N00014-93-C-0042**

Prepared for

**ONR**

Office of Naval Research

800 N. Quincy Street

Arlington, VA 22217-5660

**CONTENTS**

**3**

**Contents**

**1. SUMMARY 6**

**2. INTRODUCTION 7**

**3. TECHNICAL APPROACH 10**

    3.1 Description of the proposed shipboard Turbulent Eddy Profiler . . . . . 10

    3.2 Sensitivity Analysis . . . . . 15

**4. APPLICATION OF TEP TO BOUNDARY LAYER RESEARCH 17**

**5. SHIPBOARD OPERATION 20**

    5.1 Specifications of the Knorr . . . . . 20

        5.1.1 Shipboard requirements . . . . . 20

**6. COST ANALYSIS 26**

**7. TECHNOLOGY SPIN-OFFS 26**

    7.1 low cost boundary layer wind profiling . . . . . 28

    7.2 airport safety . . . . . 29

Accession For	
NTIS	<input checked="" type="checkbox"/>
DTIC	<input type="checkbox"/>
Unannounced	<input type="checkbox"/>
By	
Date	
Approved	
Disc	
A-1	

## List of Figures

1	Block diagram of the proposed shipboard TEP system. . . . .	11
2	Block diagram of the microwave receiver/coherent integrator subsystem . .	12
3	Photograph of the microwave receiver/coherent integrator. The receiver occupies the two left hand compartment of the enclosure. . . . .	12
4	Block diagram of the transmitter subsystem . . . . .	13
5	Minimum detectable $C_n^2$ versus altitude computed from parameters given in Table 1. . . . .	16
6	Isosurfaces of vertical temperature flux (green) and temperature structure-function parameter, $C_t^2$ (red) as generated by LES. Lower images are front and side views of highlighted region. . . . .	18
7	Profile of the Knorr showing proposed location of the TEP array. . . . .	21
8	Close-up view of proposed location of TEP array aboard the Knorr. . . . .	22
9	Graph showing clutter levels for which signal exceeds clutter as a function of $C_n^2$ and range. Clutter suppression due to transmitter and receiver antenna clutter fences =30 dB. . . . .	25

**List of Tables**

<b>1</b>	<b>TEP system parameters . . . . .</b>	<b>14</b>
<b>2</b>	<b>TEP hardware costs . . . . .</b>	<b>27</b>
<b>3</b>	<b>hardware costs for shipboard deployment . . . . .</b>	<b>27</b>

## 1. SUMMARY

This report details research performed by Quadrant Engineering under ONR SBIR contract no. N00014-93-C-0042. The purpose of this study was to determine the feasibility of deploying a shipboard turbulent eddy profiling (TEP) radar system for studying the dynamics of the marine boundary layer. A similar system is currently being developed by the University of Massachusetts to study the atmospheric boundary layer over land. During the phase I study, Quadrant Engineering reviewed the design of the land based system, and determined that a slightly scaled down version of that system would be suitable for deployment on a large research vessel, such as the Knorr, operated by Woods Hole Oceanographic Institute. In this report, we present a design for the shipboard TEP system and consider the particular requirements of installation on the Knorr. We also describe the application of TEP to boundary layer research, especially in terms of complimenting Large Eddy Simulation (LES) models. Finally, we review the major hardware costs associated with deploying a shipboard TEP system, and review technological spinoffs of this research.

## 2. INTRODUCTION

The dynamics of the Marine Boundary Layer (MBL) is a complex problem involving oceanic and atmospheric processes as well as interactions at the air-sea interface. Progress towards improving the theoretical understanding of the MBL has been hampered not only by the difficulty of modeling these often nonlinear processes and interactions but also by the difficulty of carrying out experimental programs at sea. Furthermore, the role of intermittent and directional processes is now beginning to be addressed, and a better understanding of these processes is viewed as critical in determining air-sea fluxes of momentum, heat, and moisture.

The problem of improving our understanding of the MBL is currently the subject of an ONR Accelerated Research Initiative (ARI) involving a large number of scientists and engineers. A recent MBL ARI workshop [1] identified the importance of measuring atmospheric turbulence in the boundary layer as a means of quantifying parameters such as momentum flux, turbulence dissipation rate, and Reynolds shearing stresses. In addition, the importance of coherent structures, such as vortices, wakes and jets [2], was emphasized. Such structures are thought to be very important in determining the overall structure of the MBL and may play an important role in governing transport of momentum and heat. A recent symposium on the directions of research into turbulence emphasized the need for experimental techniques which will let researchers "see" the turbulent vorticity field: "Measurement techniques which can adequately resolve the vorticity field...in space and time will bring about a major advance in defining and understanding coherent structures and turbulence" [2]. To address this need, Quadrant Engineering was awarded a phase I SBIR to study the development of a shipboard

*Turbulent Eddy Profiler, (TEP) system.* The system resulting from this study has the potential to continuously monitor the intensity of atmospheric turbulence over approximately two thousand volume cells and to update those measurements several times a minute. Using a technique called *digital beamforming* the TEP system *simultaneously* monitors all pixels within the field of view of the radar. This capability makes TEP a true four-dimensional remote sensing tool.

#### *Conventional radar wind profiling*

During the last 15 to 20 years, radars have been developed to remotely measure wind velocity in the clear atmosphere. The reflection of electromagnetic waves by atmospheric turbulence is a well known phenomenon [3]. Highly sensitive radars specifically designed to measure these weak reflections may be used to track the movement of small scale turbulence, thereby tracking the wind field. Such systems are known as clear-air radar wind profilers [4]. The National Oceanic and Atmospheric Administration (NOAA) has recently installed 32 stratospheric/tropospheric (S/T) wind profilers at various locations in the continental United States, capable of profiling winds from .5 km to 16.25 km altitude [5]. The downside of S/T profilers is their large size, high power requirements, and the fact that they cannot profile winds at altitudes below 500 m.

To address the shortcomings of S/T profilers, a new class of radar wind profiler has been developed to remotely sense winds in the atmospheric boundary layer (0 to approximately 2 km altitude) [6], [7]. Boundary layer profilers are compact (1 m x 1 m antennas), required only modest transmitter power (2-20 W average), and have minimum heights of approximately 100 m. From a cost standpoint, boundary layer profilers have the advantage

of being able to utilize economical technologies such as printed circuit antennas, solid-state power amplifiers, and monolithic receivers. These profilers are capable of measuring wind velocity at roughly 100 meter intervals in altitude, but do not directly address the four-dimensional turbulence imaging problem.

*digital beamforming technique*

Conventional wind profilers are capable of reporting a single wind velocity vector at evenly spaced altitudes above the instrument, resulting in a two-dimensional measurement (time and one spatial dimension). To address the need for four-dimensional imaging of the turbulent atmosphere, the University of Massachusetts Microwave Remote Sensing Laboratory (MIRSL) has recently been awarded a five year contract to fabricate a Turbulent Eddy Profiling radar system for boundary layer research. This contract has been awarded by the Army Research Office (ARO) as part of a cooperative University Research Initiative (URI) involving the UMass and Pennsylvania State University's Department of Meteorology. This system consists of 91 boundary layer wind profilers in a closely spaced array. By utilizing digital beamforming techniques this system will simultaneously generate over 40 contiguous beams within a 25° field of view. While digital beamforming arrays have been used in DoD systems for over a decade, such techniques have proven too costly in the past for commercial or research use. However, a steady decline in the cost of microwave, data acquisition, and signal processing hardware has made this exciting technology affordable for nonmilitary applications.

In this report, we describe a slightly scaled down version of the UMass TEP system, customized for operation on a large research vessel. The spatial and temporal resolution of

the proposed shipboard system will allow the structure and evolution of the wind field and turbulence in the MBL to be measured on a scale that is as fine as or in some cases finer than that currently being used for fine-scale atmospheric turbulence simulation models, such as Large Eddy Simulation (LES) [8]. In addition, the proposed system will be capable of monitoring turbulence through clouds and fog, conditions that prevent use of optical systems such as lidars.

### **3. TECHNICAL APPROACH**

#### **3.1 Description of the proposed shipboard Turbulent Eddy Profiler**

A block diagram showing the major subsystems of the proposed shipboard TEP radar is presented in Figure 1. The system employs separate transmit and receive antenna apertures, and a receiver array consisting of a 61 element hexagonal grid of printed circuit antennas. Each antenna in the receiver array will have its own microwave receiver that downconverts the incoming signal to an intermediate frequency (IF) of 30 MHz, where in-phase and quadrature detection (I/Q) takes place. Following the 10-bit A/D converter is a digital summing loop that coherently integrates 400 samples at each range gate before the signals are stored. A block diagram and photograph of the receiver/coherent integrator subsystem is shown in Figures 2 and 3. Due to ever lowering costs of microwave and digital circuitry, this entire subsystem can be manufactured for under \$2000.

A block diagram of the transmitter is shown in Figure 4. The transmitter also includes

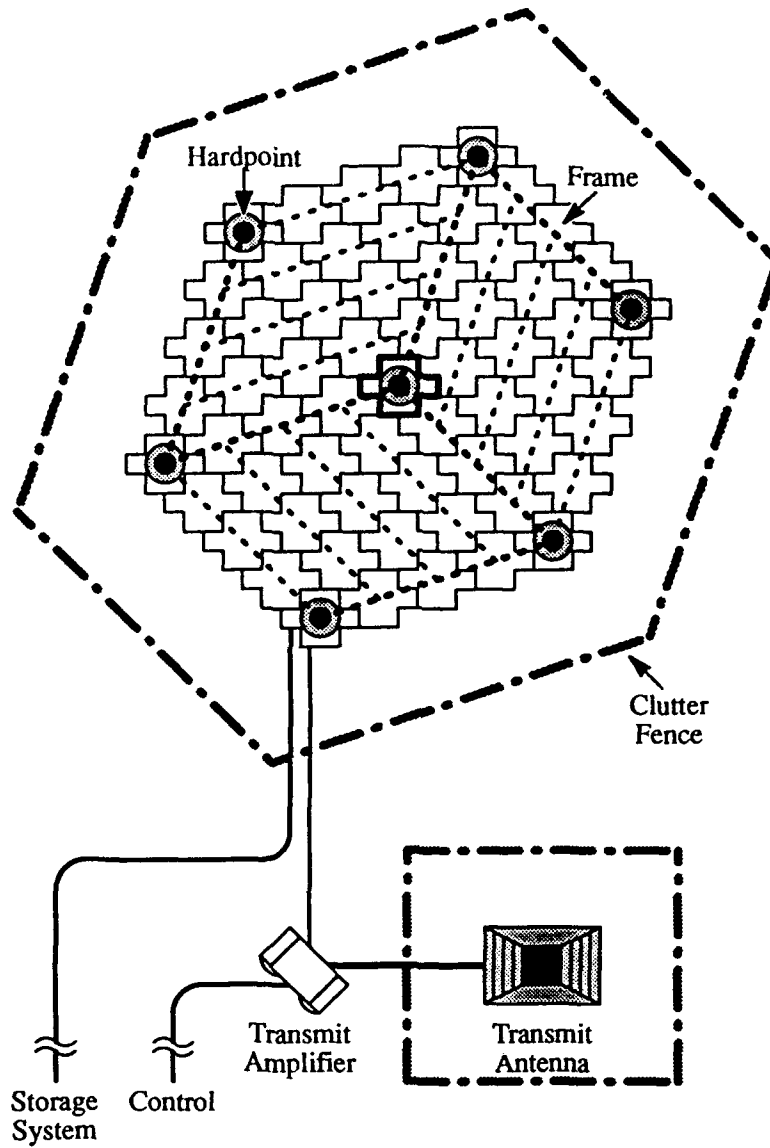
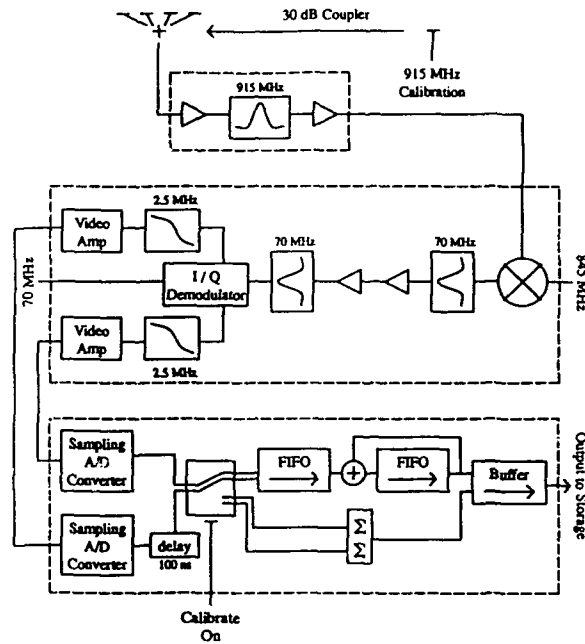
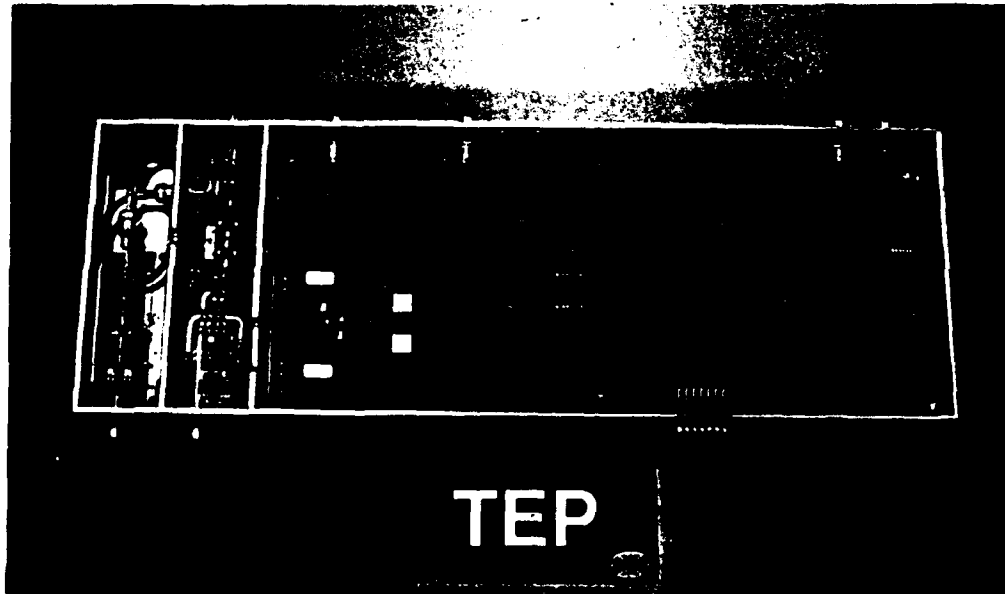

Figure 1: Block diagram of the proposed shipboard TEP system.



**Figure 2: Block diagram of the microwave receiver/coherent integrator subsystem**



**Figure 3: Photograph of the microwave receiver/coherent integrator.**

The receiver occupies the two left hand compartment of the enclosure.

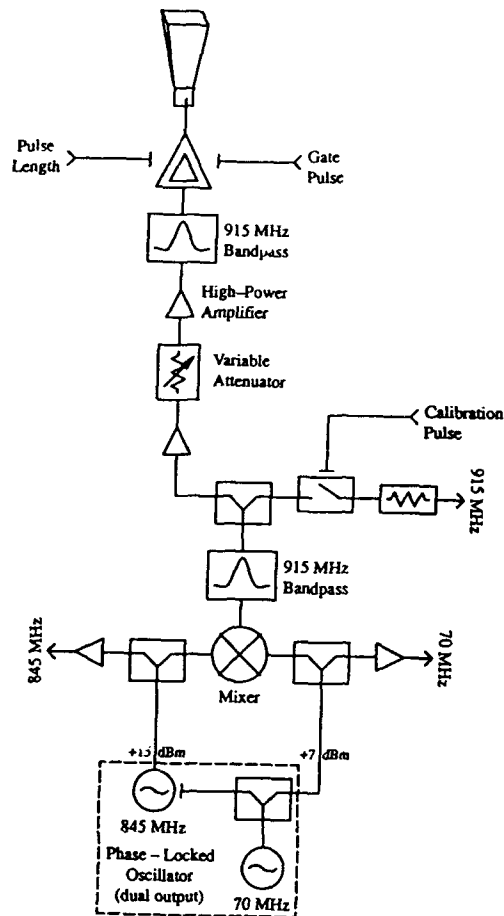

Figure 4: Block diagram of the transmitter subsystem

the reference oscillator at 70 MHz, that generates all of the signals (local oscillator and calibration signal) necessary to run all 61 receivers. The proposed transmitter power amplifier utilizes a triode that produces 50 kW peak power pulses of 200 ns duration, with a maximum duty cycle of .01. This amplifier feeds a very low sidelobe scalar feed horn antenna, developed by the University of Massachusetts Antenna Laboratory. The low sidelobes reduce the level of power scattered by clutter near the horizon. In addition, a clutter fence will most likely be used to further reduce clutter from the ocean surface. A summary of pertinent system parameters is provided in Table 1.

**Table 1: TEP system parameters**

parameter	specification
nominal operating frequency	915 MHz
wavelength, $\lambda_0$	.328 m
transmit power, $P_t$ , peak	50 kW
pulse duration, $\tau$	200 nS
average power, $P_{ave}$	400 W
pulse repetition frequency, PRF	40 KHz
antenna effective area, $A_e$	.43 $m^2$
field of view, $\phi_{max}$	25°
array beamwidth, $\phi_{pixel}$	4.3°
system noise temperature, $T_s$	150 K
transmitter/receiver transmission line loss, $\alpha_t\alpha_r$	.5
overall processor efficiency, $F_1F_2$	.5
nominal spectral width, $\delta f$	12 Hz
FFT length, $N_{FFT}$	64 point
coherent average length, $n_c$	400 point

### 3.2 Sensitivity Analysis

In the phase I proposal, we presented a sensitivity analysis based on the existing TEP concept. Since that time we have substantially increased the system sensitivity by increasing the peak transmit power by a factor of 12. In addition, to simplify processing, we have elected to integrate the same number of spectra at all range gates, which allows use to use the radar range equation for conventional radar wind profilers [7]:

$$\frac{S_r}{\delta S_n} = \frac{P_{ave} A_e F_1 F_2 c \tau \eta \alpha_t \alpha_r \sqrt{n_i}}{16 \sqrt{2} \pi R^2 k T_s \delta f} \quad (1)$$

where  $S_r$  is the power spectral density of the signal;  $\delta S_n$  is the power spectral density of the noise;  $P_{ave}$  is the average transmitter power;  $A_e$  is the effective transmit antenna aperture;  $F_1$  fractional received power passing through the receiver filter;  $F_2$  fractional received power passing through the coherent integration process;  $c\tau$  = pulse length in m;  $\eta$  = volume reflectivity in  $m^{-1}$ ;  $\alpha_t, \alpha_r$  = transmitter and receiver transmission line loss;  $n_i$  = the number of power spectra averaged together to reduce noise fluctuation;  $R$  is the range to the center of the pixel in m;  $k$  is Boltzmann's constant;  $T_s$  is the system noise temperature, neglecting transmission line losses; and  $\delta f$  is the signal bandwidth (i.e. the half-power bandwidth of the signal spectrum).

Substituting the parameters given in Table 1 into the equation above, Figure 5 was generated to display the minimum detectable  $C_n^2$  versus altitude (range). In this figure, the number of spectra integrated was limited to 10, corresponding to an updated image every 6.4 s. Such a rapid update rate will ensure that minimal resolution is lost due to motion of

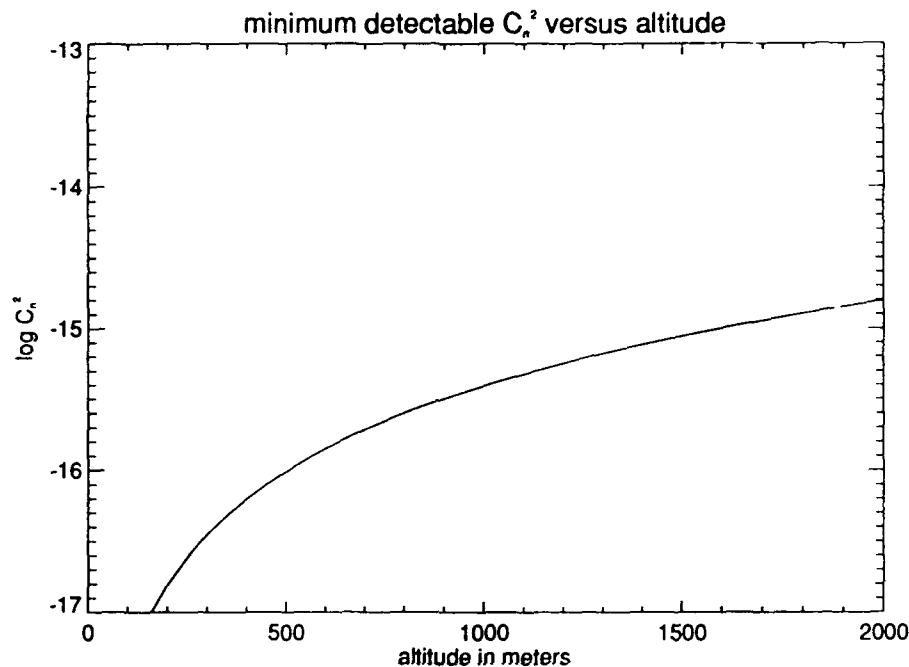

**Figure 5: Minimum detectable  $C_n^2$  versus altitude computed from parameters given in Table 1.**

the atmosphere through the resolved pixels.

Discussions with Dr. R. Rogers of McGill University and Dr. E. Gossard of CIRES (U. Colorado) indicated that  $C_n^2$  over the ocean is likely to be in the range of  $10^{-13}$  to  $10^{-14}$  at a height of 1 km.  $C_n^2$  as high as  $10^{-11}$  has been reported in the tropical Pacific [10] while Gossard cites estimates of  $C_n^2$  in the range of  $10^{-13}$  to  $10^{-15}$  below 2 km [11]. From Figure 5 it is clear that we should be able to study the turbulent structure of the atmosphere to an altitude of 2 km with good signal-to-noise performance.

#### 4. APPLICATION OF TEP TO BOUNDARY LAYER RESEARCH

Understanding the structure of the turbulent atmosphere is one of the most challenging problems in classical physics. While the equations governing atmospheric motion were derived long ago, numerical solutions may never be possible due to the range of scales involved (microns to kilometers), the complexity of boundary conditions, and the importance of time evolution. In addition, researchers now realize that the simplifying assumptions of homogenous boundary conditions, and homogeneous structure are naive: the atmosphere is by nature nonstationary, anisotropic, and inhomogeneous. Thus, the atmospheric sciences community is looking for new tools — theoretical, computational, and observational — to better grapple with the complexities of the turbulent atmosphere.

One promising computational method for dealing with non-homogeneous or *coherent* structures in the atmosphere is Large Eddy Simulation (LES) a technique in use at a number of institutions, including NCAR and Penn State University (PSU). Through their cooperation with the University of Massachusetts Microwave Remote Sensing Laboratory, PSU researchers are beginning to look at LES-generated parameters that could be detected by the TEP system, namely the structure function parameter  $C_n^2$ , which is related to the underlying structure parameters for water vapor and temperature,  $C_q^2$  and  $C_t^2$ , as well as their covariance,  $C_{tq}$ . An example of an LES simulation of an inhomogeneous region of the ABL is shown in Figure 6 where isosurfaces of  $C_t^2$  are plotted in red, along with vertical temperature flux in green.

LES-generated data sets of  $C_n^2$  have already been used in TEP simulations. However, the more important synergism between LES and TEP will be the ability to use TEP to

Isosurfaces of Vertical Temperature Flux and Temperature Structure-Function Parameter



Vertical Temperature Flux (Yellow/Solid)

Temperature Structure-Function Parameter (Red/Wire)

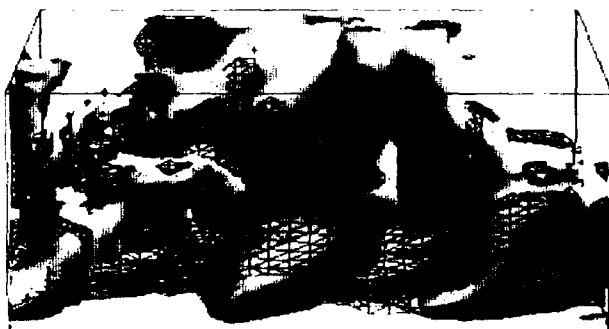

Figure 6: Isosurfaces of vertical temperature flux (green) and temperature structure-function parameter,  $C_t^2$  (red) as generated by LES. Lower images are front and side views of highlighted region.

validate the performance of LES, which will hopefully improve the ability of LES to simulate atmospheric dynamics. In addition, LES output can be used to help visualize the types of structures that will be measured with TEP, and can guide us in defining experiments to best use the instrument.

John Wyngaard of PSU, one of the leading researchers in LES, is currently involved with the Marine Boundary Layer Accelerated Research Initiative (MBL-ARI) which is geared toward better understanding coherent structures associated with the air-sea interface. John has been working with researchers from UMass to plan experiments with TEP and will be heavily involved with analysis of the initial TEP experiments. The PI of this phase I study is also the senior research fellow at UMass responsible for building and running the TEP system for the university program. We believe that Quadrant Engineering's close contact with UMass and PSU provides the best opportunity for success during phase II and phase III. Finally, TEP is the only known instrument with the potential to provide 4-dimensional maps of atmospheric turbulence capable of resolving significant energy containing scales over a sizable region of the sky. Thus, we believe that TEP will make a significant contribution to studying inhomogeneous phenomena like that shown in Figure 6, both in the ABL through the University effort and in the MBL through this ONR-sponsored project.

## **5. SHIPBOARD OPERATION**

### **5.1 Specifications of the Knorr**

During phase I the PI contacted a number of people in the Navy and at Woods Hole to discuss mounting the TEP system on board a research vessel. Due to the large size of the receiver array it was decided that the so-called A-2 class ships would be most appropriate for such an installation. Two candidate ships, the Knorr and the Atlantis II, are operated by NOAA out of WHOI. At 270', the Knorr is the larger of the two ships, and was in port during August. On August 24, the PI received a tour of the Knorr from Don Moller of the Woods Hole Marine Operations Office. A section of the ship was located that looks like it could easily be modified to accommodate the TEP array without interfering with normal operation of the ship. Figure 7 is a profile of the ship, showing the proposed location of the TEP array. Figure 8 shows a close up of the area where we hope to locate the array. The container (highlighted by arrow) is approximately 16' in length. The array will easily fit along the top of this container and can be supported with additional frame work above the open area in the foreground of the photograph. The transmit antenna, having a footprint of about 5'x5' (with clutter fence) can be located near this array, or placed at any convenient location within 50' of the receiver.

#### **5.1.1 Shipboard requirements**

Operation from a ship poses two special problems for this system, 1) the requirement to compensate the antenna for roll, pitch and acceleration and 2) the presence of ocean surface

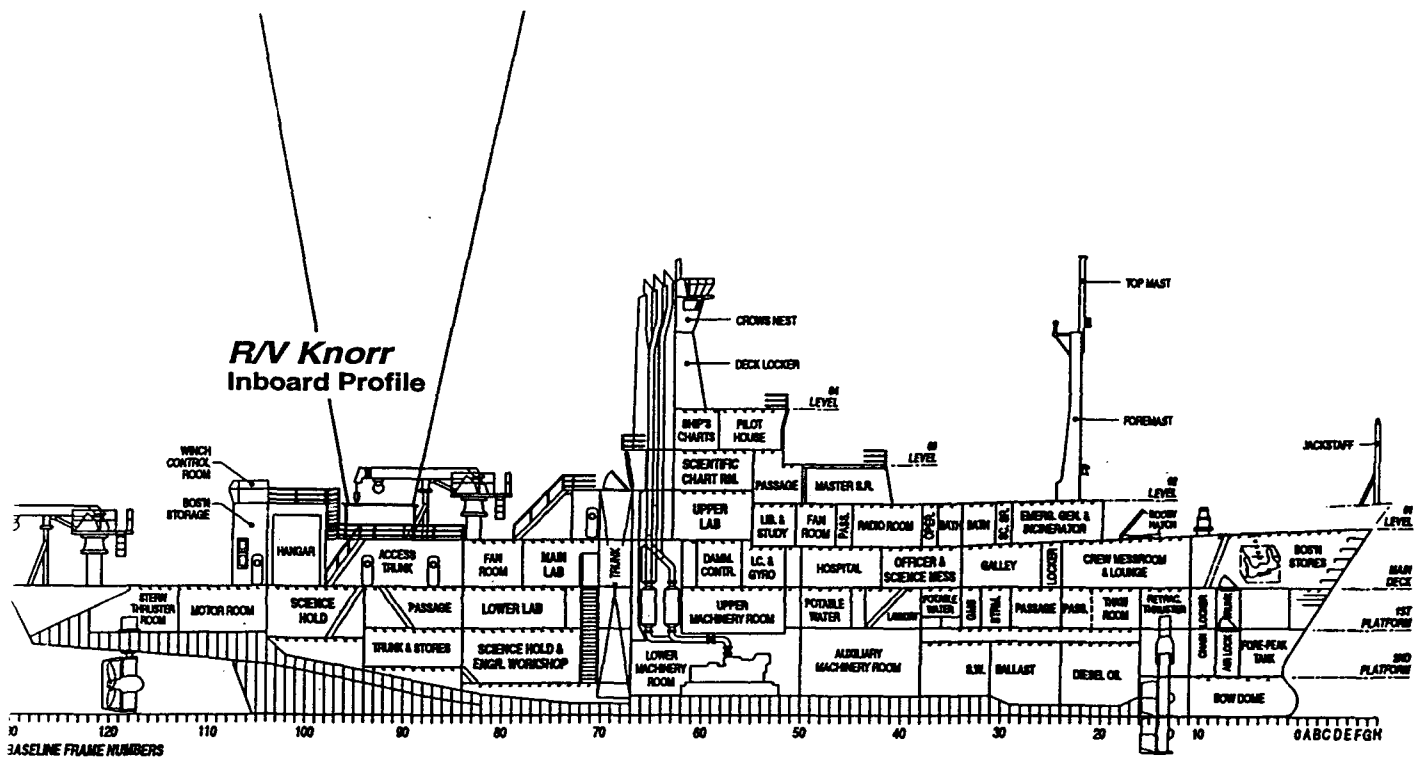
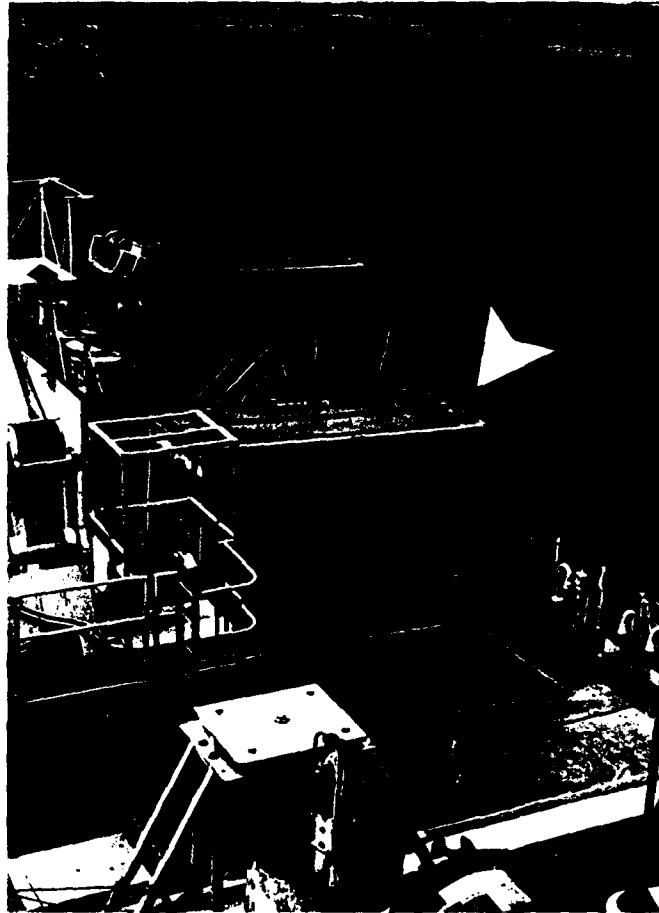

Figure 7: Profile of the Knorr showing proposed location of the TEP array.



**Figure 8: Close-up view of proposed location of TEP array aboard the Knorr.**

clutter that has statistics similar to that of the atmosphere. These problems are discussed separately below.

1. *roll and pitch compensation*

The TEP receiver uses digital beamforming (DBF) to steer the received beam to any point within the field of view of the transmit antenna and the individual receiver element. Thus, motion of the ship may be accounted for in the DBF algorithm such that the output of the algorithm is always referenced to a stationary reference frame. There are, however, limitations to this electronic correction: if the ship rolls or pitches far enough, then many pixels will move out of the 25° field of view of the transmitter and the individual receiver elements. Thus, when a ship pitches or rolls  $\pm 10^\circ$  only the central pixels will remain illuminated continuously. Even relatively large ships such as the Knorr can easily roll  $\pm 10^\circ$  under typical conditions. Pitch is generally less than roll, but is still substantial enough to require correction.

To avoid the excessive cost of building a stabilized platform, we propose to monitor pitch and roll and to store data only when the system is viewing within  $\pm 6.5^\circ$  of vertical. Assuming that the motion of the ship is sinusoidal, and assuming that roll is the dominant motion, then the antenna will be pointing within  $\pm 5^\circ$  of vertical about 44 percent of the time for roll  $= \pm 10^\circ$ . Thus, instead of generating ten images per minute the system will generate an average of four to five images per minute, which is more than adequate for observing the time evolution of the turbulence.

## 2. *correction for accelerations*

In a report on shipboard tests of a 915 MHz wind profiler [9] NCAR and NOAA found that mean winds could be accurately measured without the need of correction for accelerations due to motion of the ship. However, because such profilers usually integrate over periods of tens of seconds, the time averaged acceleration was nearly zero, and thus had little effect on the measurement of wind velocity. However, for the TEP system, we anticipate that averaging time will be on the order of 10 s or less, depending on the velocity of the turbulent structure under observation. Since the ship will move up and down at a rate on the order of .1 Hz we expect that our 10 s averages will be significantly affected by such accelerations. Thus, we plan to utilize a vertical axis accelerometer to compensate for this motion.

## 3. *clutter from the ocean surface*

The radar cross-section of the ocean surface is known to roll off rapidly at incidence angles near grazing. Although no comprehensive data base exists for near grazing ocean backscatter at 1 GHz, data measured at other frequencies suggest that the normalized radar cross-section (NRCS) could be quite low for incidence angles  $> 85^\circ$  [12]. Based on an expected antenna height of 8 m above mean sea level, the maximum grazing angle should be no more than  $5^\circ$  at a range of 100 m and no more than  $1^\circ$  at a range of 500 m. Based on these incidence angles, we expect cross-sections on the order of -35 dB to -60 dB.

Figure 9 predicts the level at which signal will equal clutter as a function of  $C_n^2$  for two different ranges. This graph was based on the measured antenna patterns for the

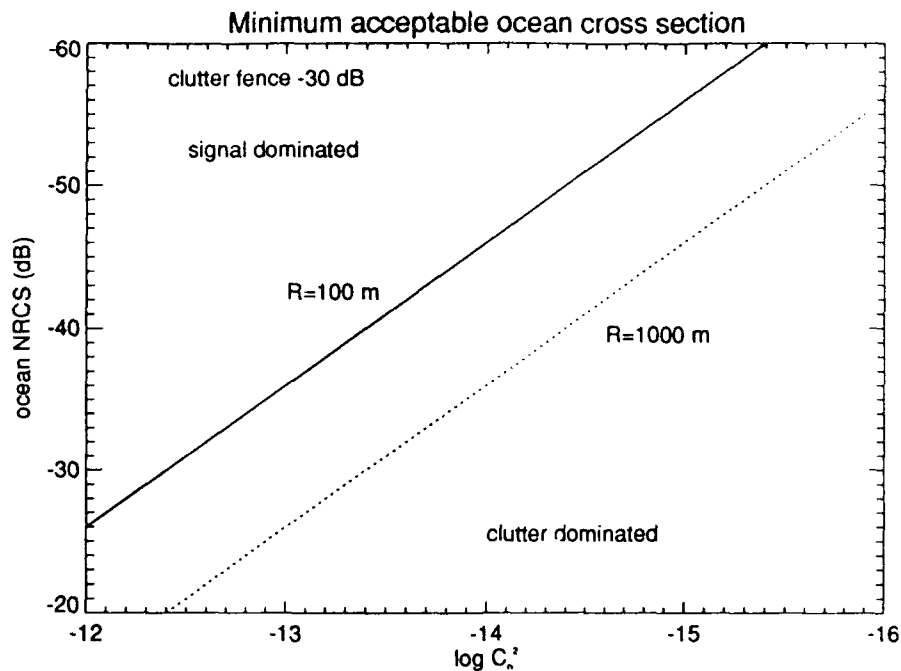

**Figure 9: Graph showing clutter levels for which signal exceeds clutter as a function of  $C_n^2$  and range. Clutter suppression due to transmitter and receiver antenna clutter fences =30 dB.**

transmit horn and receiver elements, and assumes a two-way clutter suppression of 30 dB can be achieved through use of a clutter fence surrounding both the transmit and receive antennas. This plot shows that for  $C_n^2 = 10^{-13}$  and the ocean NRCS = -35 dB signal will equal clutter at a range of approximately 100 m.

## 6. COST ANALYSIS

An analysis of the cost of a shipboard TEP system was carried out, based on Sept. 1993 pricing for all components in the TEP system. These cost estimates are given in Table 2.

The costs quoted above would provide all of the hardware necessary to build the TEP radar, but do not include hardware costs associated with deploying TEP on a ship. Additional costs estimates for shipboard deployment are given below in Table 3.

While these costs are estimates, we have carefully reviewed all of the componentry required to build the TEP system, and will be basing our Phase II proposal on the prices listed in Table 2.

## 7. TECHNOLOGY SPIN-OFFS

While the proposed TEP system is intended for research into turbulent phenomena in the marine boundary layer, the technological advances incorporated in this development could have direct application to a number of problems in the area of clear-air scattering. The need for clear air wind profiling for aircraft safety, pollution monitoring and for global wind circulation monitoring (especially over the ocean) are all areas of growing interest and need. However, at current prices, boundary layer profilers are prohibitively expensive for wide spread use. We believe that technology developments made through phase II SBIR research will allow Quadrant Engineering to develop wind profiling and wind shear detection products that are much cheaper than current systems. Some of these products, and the reasons we hope to be able to lower their cost, are described below.

**Table 2: TEP hardware costs**

category	quantity	cost estimate
receiver antennas	65	\$44,325
transmit antenna	1	5,600
receivers	65	64,725
digital integrators	65	27,278
transmitter	1	92,880
data storage system	1	20,000
host computer	1	7,850
total		262,658

**Table 3: hardware costs for shipboard deployment**

category	quantity	cost estimate
frame to support antenna	1	\$5,000
clutter fence	2	3,000
calibration source	1	2,000
misc. electronics		4,000
misc. hardware		2,000
total		16,000

## 7.1 low cost boundary layer wind profiling

Boundary layer (0-2 km) wind profiling over land is now being addressed primarily by compact 915 MHz wind profilers utilizing techniques similar to those employed with the TEP system. However, these systems range in price from \$80-150K, depending on the complexity of the hardware. While this price is affordable for many applications, we believe that it is prohibitively high if a large number of such systems are to be deployed.

During the original conception of the TEP system, we realized that it was becoming possible to build extremely low cost microwave receivers, which is why it was practical to use individual receivers for each element in the TEP receiver. As seen from the cost analysis above, the projected cost of each microwave receiver in the array is only \$1000, a very small cost by historic standards. In fact, cellular telephones utilize similar receivers at close by frequencies that cost less than \$100 to produce thanks to MMIC technology.

Quadrant is currently building a boundary layer wind profiler for NSF through the SBIR program using standard off-the-shelf components, for which the cost of parts is currently about \$20,000. By using the TEP receiver design, and by buying components in large quantities, we believe the overall hardware cost could be reduced to the range of \$8000-\$10000. Thus, wind profilers could be produced at a profit for considerably less cost than current systems, perhaps as low as \$30,000. This estimate assumes that the rather substantial cost of software development, that must normally be recouped through sales, would be paid for through phase II SBIR funds.

Applications of low cost boundary layer profilers include denser networks of land-based profilers, networks of buoy mounted profilers, and airport surveillance for wind shear de-

tection. This latter case, currently of great interest to the FAA and commercial airlines, is described below.

## 7.2 airport safety

A substantial effort is currently underway to detect Low Altitude Wind Shear (LAWS) at airports and in-flight. A recent article summarizing the current state of development of systems to detect shear [13] cites the use of terminal Doppler weather radars (TDWR) for airport surveillance and use of on-board forward-looking X-band radars to detect dangerous wind shear conditions, especially wet or dry microbursts. While such systems have already demonstrated their ability to detect LAWS, the systems are expensive and are thus envisioned for large airports and commercial aircraft, only. However, the many small airports around the country that service private aircraft could benefit from low-cost wind profilers that would have the ability to monitor the 3-D wind field especially along runway approaches, where the danger of shear is greatest.

Meanwhile, for larger airports where more sophisticated information about the complex structure of the wind field may be of interest, we believe that the TEP system, as described in this report, would provide a wealth of information about the nature of the turbulence in the first 1-2 km of the atmosphere. While the exact nature of the information that TEP could provide is a question that will be answered only by experimentation, it may prove to be of great value to airport surveillance in the future.

REFERENCES

- [1] MBL ARI Workshop, Monterey, CA, March 1-3, 1992.
- [2] Lumley, J.L. ed., *Lecture Notes in Physics, Vol. 357: Whither Turbulence? Turbulence at the Crossroads*, Springer-Verlag, New York, 132-149, 1989.
- [3] Tatarski, V.I. (trans. from Russian by R.A. Silverman), *Wave Propagation in a Turbulent Medium*, Dover Publications, New York, 1961.
- [4] Gage, K.S. and B.B. Balsley, "Doppler Radar Probing of the Clear Atmosphere", *Bulletin American Meteorology Society*, Vol. 59, No. 9, 1074-1093, 1978.
- [5] Unisys Wind Profiler Training Seminar Manual, Unisys Corp.
- [6] Ecklund, W.L., D.A. Carter, B.B. Balsley, "A UHF Wind Profiler for the Boundary Layer: Brief Description and Initial Results", *J. Atmos. Ocean Tech.*, v. 5, n. 3, 432-441, 1988.
- [7] Balsley, B.B., "Design Considerations for Coherent Radar Systems for Probing the Troposphere, Stratosphere, and Mesosphere", *Preprints, 18th Conference on Radar Meteorology (Atlanta)*, AMS, Boston, 387-390, 1978.
- [8] Wyngaard, J.C. and Taylor, P.A., Eds., *Planetary Boundary Layer Model Evaluation Workshop*, WCRP-42, WMO/TD-No. 378, World Meteorological Organization, Geneva.
- [9] D. A. Carter, W.L. Ecklund, K.S. Gage, M. Spowart, H.L. Cole, E.F. Chamberlain, W.F.

- Dabberdt, and J. Wilson, "First Test of Shipboard Wind Profiler", *Bulletin American Meteorological Society*, v. 73, n. 10, pp. 1587-1592, 1992.
- [10] R.R. Rogers, C.A. Knight, J.D. Tuttle, W.L. Ecklund, D.A. Carter, and S.A. Ethier, "Radar reflectivity of the clear air at wavelengths of 5.5 and 33 cm", *Radio Science*, v., 27, 645-559, 1992.
- [11] D. Atlas, ed. *Radars in Meteorology*, American Meteorological Society, Chapter 27a, pg. 510, 1990.
- [12] M. Skolnik, *Introduction to Radar Systems*, 2<sup>nd</sup> ed., McGraw-Hill, New York, p. 475, 1980.
- [13] D. D. Aalfs, E. G. Baxa and E. M Bracalente, "Signal Processing Aspects of Windshear Detection", *Microwave Journal*, v. 36, n. 9, 76-96, 1993.