



BULLETIN

OFFICE OF NAVAL RESEARCH EUROPEAN OFFICE Box 39, FPO New York 09510-0700 Phone (AV)235-4131 (Comm) 409-4131

MASB 11-89

31 January 1989

ADAPTIVE NOISE CANCELLATION AT PLESSEY

Background. Self-noise generated by internal machinery of the sonar platforms (surface ship or submarine) can be a limiting factor in sonar performance at slow speeds. Traditional noise reduction techniques, such as selection of quiet machinery, mount isolation, pipework isolation, etc., can do much to reduce the noise problem. However, further improvement by these techniques eventually ceases to be cost-effective. It may then only be possible to reduce the residual noise at the array using adaptive cancellation. Adaptive cancellation of sonar self-noise removes the noise interference electronically in the sonar signals themselves, and does not involve any mechanical reduction. With current sonar processing architecture, the cancelling can be done at comparatively low cost by the addition of extra vector processors either pre- or post-beamformer.

Principles of Operation. (See Figure 1.) The signal source represents the output from a sonar transducer or a beam output from a beamformer containing the wanted target signal (but also unwanted noise) from, for example, a vibrating machine via some unknown path represented by the linear filter. This signal is referred to as "the primary." A reference signal is taken from the machine, perhaps by attaching an accelerometer at its seating. The method relies on this reference signal being highly correlated with the unwanted noise in the sonar channel; however, no information is required concerning the path between the noise source and the sonar. The reference signal is passed through a finite impulse response digital filter which is adapted automatically to simulate the path between the noise source and the sonar. The filtered reference should then equal the noise in the sonar channel. The output of the filter is therefore subtracted from the primary, and cancels the unwanted noise.

Real-Time Analog Processor. The analog processor is a single plug-in board designed for the expansion slots of the IBM PC XT computer. It offers a simple and economical means of interfacing analog signals to both the on-card digital signal processor (DSP)

ANC Filter Principles

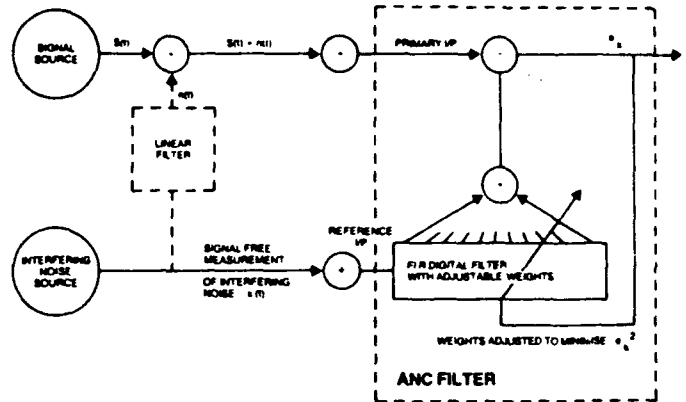

Figure 1. ANC filter principles.

and the host computer. In normal operation the DSP is programmed from the PC to perform a desired function, and the resulting data is then either transferred to the host, where further processing or interfacing may be applied, or converted at the card analog output port. The card may be used for general signal analysis or algorithm development. In many applications the power of the DSP allows real-time processing to be carried out.

For further information contact Plessey Naval Systems Limited, Wilkinthrop House, Templecombe, Somerset BA8 0DH United Kingdom. Telephone 44-963-70551.

ONREUR point of contact: CDR John P. Simpson, USN, Environmental Systems and Oceanographer

Distribution
ASW
Environmental Systems
Submarine

By	
Date	
Availability Codes	
Dit	Available for Special
A1	

DTIC ELECTE
OCT 14 1993

93-23933



NOT FOR PUBLIC RELEASE