

2

AD-A273 809



ARMY RESEARCH LABORATORY



Monte Carlo Analysis of GPS Performance Based on Artillery Flight Mission and Antenna Interaction

by George Wiles

ARL-TR-289

November 1993

DTIC
ELECTE
DEC 16 1993
S E D

**
424 778

93-30386



Approved for public release; distribution unlimited.

98 12 15022

The findings in this report are not to be construed as an official Department of the Army position unless so designated by other authorized documents.

Citation of manufacturer's or trade names does not constitute an official endorsement or approval of the use thereof.

Destroy this report when it is no longer needed. Do not return it to the originator.

REPORT DOCUMENTATION PAGE			Form Approved OMB No. 0704-0188	
Public reporting burden for this collection of information is estimated to average 1 hour per response, including the time for reviewing instructions, searching existing data sources, gathering and maintaining the data needed, and completing and reviewing the collection of information. Send comments regarding this burden estimate or any other aspect of this collection of information, including suggestions for reducing this burden, to Washington Headquarters Services, Directorate for Information Operations and Reports, 1215 Jefferson Davis Highway, Suite 1204, Arlington, VA 22202-4302, and to the Office of Management and Budget, Paperwork Reduction Project (0704-0188), Washington, DC 20503.				
1. AGENCY USE ONLY (Leave blank)	2. REPORT DATE November 1993	3. REPORT TYPE AND DATES COVERED Final, 1/92 to 2/93		
4. TITLE AND SUBTITLE Monte Carlo Analysis of GPS Performance Based on Artillery Flight Mission and Antenna Interaction			5. FUNDING NUMBERS DA PR: AH16 PE: P62120	
6. AUTHOR(S) George Wiles				
7. PERFORMING ORGANIZATION NAME(S) AND ADDRESS(ES) U.S. Army Research Laboratory Attn: AMSRL-SS-FG 2800 Powder Mill Road Adelphi, MD 20783-1197			8. PERFORMING ORGANIZATION REPORT NUMBER ARL-TR-289	
9. SPONSORING/MONITORING AGENCY NAME(S) AND ADDRESS(ES) U.S. Army Research Laboratory 2800 Powder Mill Road Adelphi, MD 20783-1197			10. SPONSORING/MONITORING AGENCY REPORT NUMBER	
11. SUPPLEMENTARY NOTES AMS code: 612120.H160011 ARL PR: 36E162				
12a. DISTRIBUTION/AVAILABILITY STATEMENT Approved for public release; distribution unlimited.			12b. DISTRIBUTION CODE	
13. ABSTRACT (Maximum 200 words) The accuracy of GPS (Global Positioning System) receivers depends on the geometry of the GPS satellites used in the position calculation; the receiver has optimum performance when given an unobstructed view of the sky. Previous work has shown that L-band antennas mounted on 155-mm artillery projectiles have nulls or blind spots in their patterns. A Monte Carlo analysis was performed to assess the impact on system accuracy that various sized nulls would have. The analysis found that a system using the full 24-satellite constellation is very tolerant of even large antenna nulls.				
14. SUBJECT TERMS GPS, Global Positioning System, Monte Carlo, artillery			15. NUMBER OF PAGES 32	
			16. PRICE CODE	
17. SECURITY CLASSIFICATION OF REPORT Unclassified	18. SECURITY CLASSIFICATION OF THIS PAGE Unclassified	19. SECURITY CLASSIFICATION OF ABSTRACT Unclassified	20. LIMITATION OF ABSTRACT UL	

Contents

	Page
1. Introduction	5
2. GDOP Calculation	6
3. Randomization of Parameters	7
3.1 Time of Day	8
3.2 User Location	8
3.3 Flight Mission Database	8
3.3.1 Illustrative Example	9
3.3.2 Trajectory Model Database	10
4. Normalized Flight Time	12
5. Baseline Results	13
6. Monte Carlo Repeatability	14
7. Baseline Case with Fixed Antenna Null	14
8. Monte Carlo Results	15
9. Conclusions	16
Distribution	31

Appendices

A. Firing Conditions for Artillery Missions Used in Monte Carlo Analysis	17
B. Monte Carlo Results: Best Calculated GDOP versus Normalized Flight Time and Antenna Null Conditions	21

Figures

1. Antenna nulls	5
2. Geometry for GDOP calculation	6
3. A simple GDOP calculation	6
4. Monte Carlo GDOP calculation	7
5. All possible marbles	9
6. Uniform marble distribution	9
7. Weighted marble distribution	10
8. Short-, medium-, and long-range flights	13
9. Three flights with normalized flight time	13
10. Fixed antenna nulls used in baseline calculations	14
11. Null (20°) at two orientations for baseline calculation	15

Tables

Page

1.	AFAS usage distribution.....	11
2.	Summary of possible conditions based on firing tables	12
3.	Uniform flight distribution	12
4.	Weighted flight distribution	12
5.	Baseline GDOP calculation.....	14
6.	Baseline case of various size antenna nulls.....	14
7.	Baseline case of 20° null at different orientations	15

Accession For	
NTIS CRA&I	<input checked="" type="checkbox"/>
DTIC TAB	<input type="checkbox"/>
Unannounced	<input type="checkbox"/>
Justification	
By	
Distribution /	
Availability Codes	
Drt	Avail and/or special
A-1	

DTIC QUALITY INSPECTED 1

1. Introduction

As part of an ongoing effort to improve artillery accuracy and effectiveness, the Global Positioning System (GPS) is being considered as a potential source of position information for artillery systems. Several concepts for projectile-mounted systems have been proposed. One concept involves tracking projectiles with a GPS transponder. Others involve placing a GPS receiver on a projectile for position fuzing or guidance applications.

Several factors contribute to the position accuracy of a GPS transponder or receiver system. One of these factors is the potential lack of isotropic coverage provided by the receive antenna. For optimum receiver performance, an unobstructed view of the sky is required. However, previous experience with projectile-mounted antennas near the GPS frequency has shown that there may be voids in the coverage due to nulling produced by the interaction of the antenna with the projectile body (see fig. 1). It is necessary to quantify the expected error due to the antenna nulls; to accomplish this, we performed a Monte Carlo analysis.

The accuracy of a GPS receiver may be considered to depend on two independent contributing factors. The first, the user range error (URE), accounts for the receiver's ability to measure the satellite signal's phase, the uncertainty due to the tropospheric delay, algorithmic and computational error, satellite ephemeris, and other errors. The URE is independent of the geometry of the encounter. The second factor, the geometric dilution of precision (GDOP), depends solely on the relation of the positions of the satellites and the receiver. The total error is the product of the URE and GDOP.

Figure 1. Antenna nulls.

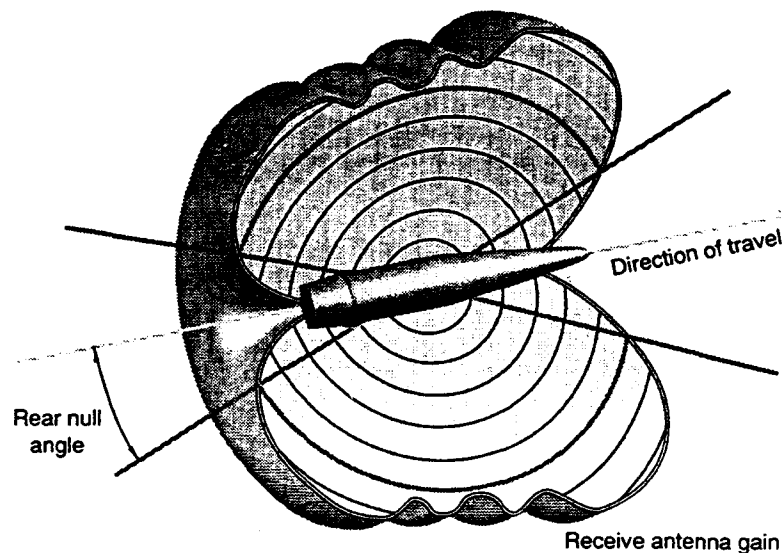

2. GDOP Calculation

The GDOP is a geometric measure of the independence of the position information supplied by each satellite. In essence, it is a measure of how well spaced the satellites used in the calculation are. In the four-satellite solution, solving for position and time error, we calculate the GDOP from the root sum of the areas of the triangles formed by the satellites, divided by three times the volume of the tetrahedron formed by the satellites and the user (see fig. 2). If the four satellites and the user are in the same plane, then the tetrahedron volume is zero, and the GDOP is infinite. Generally, a GDOP of 6 or less is considered usable; the fully deployed constellation of satellites is designed to provide a GDOP of 6 or less for all users 90 percent of the time.

The calculation of the GDOP for any one circumstance is a trivial matter. One must only determine the position of the satellites relative to the receiver, find which of these satellites are not visible because of antenna masking, and use the best calculated GDOP of the visible satellites (see fig. 3).

Figure 2. Geometry for GDOP calculation.

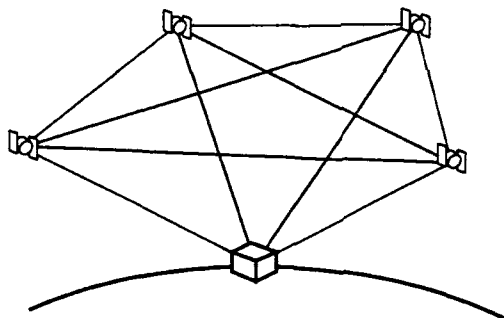
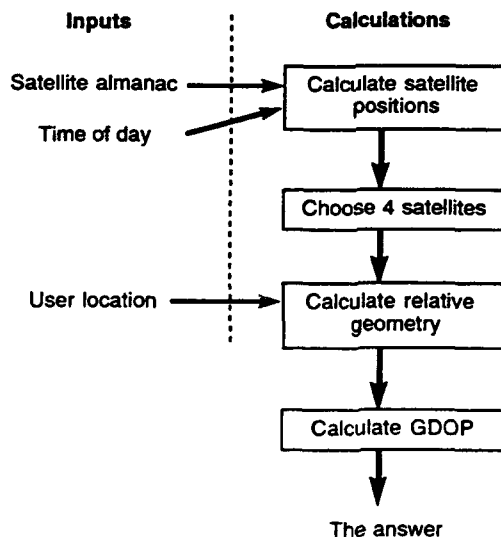

Figure 3. A simple GDOP calculation.



The difficulty in the analysis lies in incorporating the entire range of possible encounters given by the combination of artillery variables, antenna pattern, and satellite geometry. The Monte Carlo analysis is a useful way of exhaustively combining random inputs from ranges of variables and applying them to the process being studied. The result of the analysis is a distribution of outcomes (GDOP's), which has statistical significance if enough combinations are examined. It is this distribution that we need to assess the impact of antenna nulls in a system accuracy study.

3. Randomization of Parameters

Three parameters of the GDOP calculation were to be independently randomized: the time of day, the user location, and the artillery projectile flight parameters (see fig. 4).

Figure 4. Monte Carlo GDOP calculation.

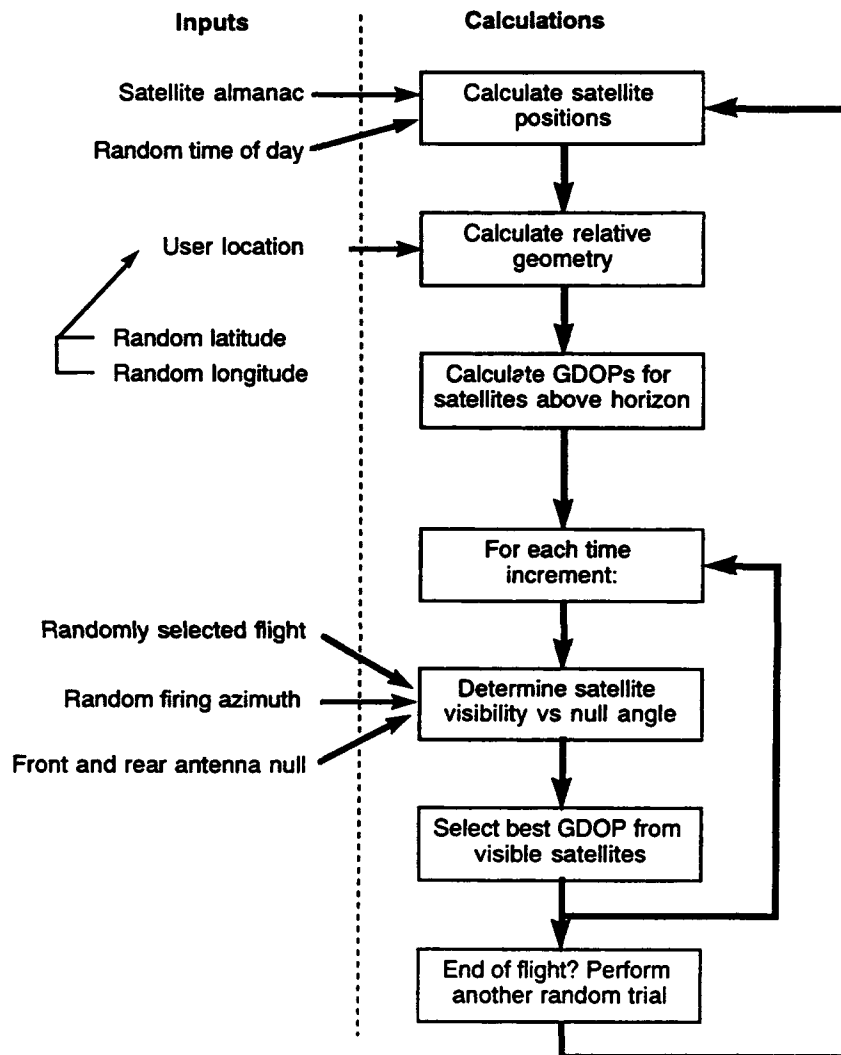

3.1 Time of Day

The proposed GPS satellite constellation consists of 24 satellites in fixed 12-hour orbits. The position of each satellite can be precisely determined from the orbital equations, which are a function of time. By uniformly randomizing time from 0 to 12 hours, one can address all the possible satellite positions. For the purpose of this exercise, a circular approximation of the orbit sufficed.

3.2 User Location

To insure that the satellite positions were unbiased, I selected the location of the user on the earth's surface at random for each encounter. Here it was assumed that any location on the surface is equally likely (land or water); the longitude was allowed to vary uniformly between -180° and $+180^\circ$, and the latitude varied as a cosine distribution between -90° and $+90^\circ$. The cosine latitude distribution accounted for the fact that there is more surface area per degree of latitude at the equator than at the poles. A spherical globe was used. The location variation is for geometric purposes only, and did not affect the distribution of environmental factors, such as mean temperature, which in turn would affect the individual flight parameters.

3.3 Flight Mission Database

By far the most difficult parameter to assess was the distribution of the flight parameters. Some difficulties are the wide variations in flight duration that arise over all operating conditions, and the problem of comparing a large quantity of disparate data. Because of the statistical nature of a Monte Carlo analysis, it is not enough to know that a projectile could be launched either nearly horizontally or nearly vertically; one must also know how much more likely it is for a projectile to be launched at a certain angle. Since a mathematical description of the distribution does not exist, a weighted set of representative trajectories was used.

For this study, I decided to create a database that not only represents every possible trajectory, but also includes an indication of the relative frequency with which that trajectory would be used in battle conditions. I provide an example to illustrate the rather convoluted method used to construct the distribution.

3.3.1 Illustrative Example

The International Marble Association is conducting scientific research into the effects of solar pressure on the travel of various marble types, to test the hypothesis that light colored marbles travel farther with the sun at their back than do dark marbles. In a controlled experiment, randomly selected marbles were rolled across a prepared surface at different times of day. The experimenters wish to fill a jar with marbles so that at the conclusion of the experiment, when the marbles are sorted by class, the distribution of marbles meets the prescribed IMA guidelines of 25-percent white, 25-percent black, and 50-percent grey for all marbles in tournament play.

For the experiment to be accurate, all varieties of marbles have to be considered (see fig. 5).

A preselection analysis determines that although light pink is a marble color, it is currently not allowed in tournament play. After light pink is removed, the uniform distribution of classes is now as shown in figure 6.

The problem is now how to fill a jar with marbles so that the overall mix matches the IMA guidelines without distorting the representation of the marbles within their class. By working toward a common factor of $4 \times 3 = 12$, we can create a modified distribution with three sets of white marbles, four sets of black marbles, and eight sets of grey marbles. This grouping satisfies the prescribed IMA guidelines and represents all marbles within their class equally (see fig. 7).

Figure 5. All possible marbles.

White		Black		Grey	
zinc white		gloss black		granite	
off white		matte black		blue grey	
pearly white		off black		green grey	
light pink					
oyster					

Figure 6. Uniform marble distribution.

	White				Black			Grey		
Class										
Percentage of total	40%				30%			30%		

Figure 7. Weighted marble distribution.

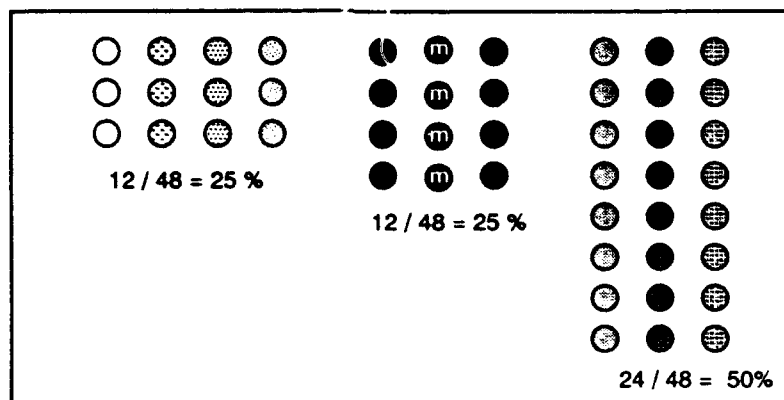

A closer examination of the marble classes indicates that there are distinct subclass groupings to consider, such as the three degrees of off-white marbles: antique white, bone white, and eggshell. This and other subclass groupings increase the size of the uniform distribution of marbles (the number of distinct samples), and as the common factor grows, so does the minimum size of the weighted distribution. The general technique to generate the weighted distribution would be the same.

3.3.2 *Trajectory Model Database*

A similar method was used to create the flight mission database. Three classes of projectile firings were considered: short (0–15 km), medium (16–24 km), and long (25–50 km) range. Within each class are the various combinations of projectile type, charge, and firing angle (quadrant elevation, or QE) to strike a target within the range class.

To create this flight mission database, I solicited help from the Artillery Effectiveness Working Group and the Field Artillery School at Fort Sill. To make the undertaking manageable, we focused our effort on the usage pattern of the Advanced Field Artillery System (AFAS). A preliminary study had been previously undertaken to identify the mix of projectiles that would complement the AFAS when fielded. With each projectile was an estimate of how often that projectile would be fired at short, medium, or long range. Table 1 is based on that study.

This information was interpreted to mean that each AFAS system would enter the battle with 60 mixed rounds, and would shoot them at the ranges in the chart.

A modified three-degree-of-freedom (3DOF) ballistic computer model was used to generate the position information for all the flights. Two parameters were used to differentiate the flights: charge

Table 1. AFAS usage distribution.

Rounds available	Type	Distribution of rounds fired according to range		
		0-15 km	16-24 km	25-50 km
25	M483A1	52% (13)	48% (12)	—
21	M795	62% (13)	24% (5)	14% (3)
5	M864	—	—	100% (5)
2	M549A1	—	—	100% (2)
7	M898	71% (5)	29% (2)	—
60	All	52% (31)	32% (19)	17% (10)

and range. Even though the AFAS may use liquid propellant, and therefore be capable of a continuously variable muzzle velocity, the old system of 11 quantized charges (designated 3G, 3W, 4G, 4W, 5G, 5W, 6W, 7W, 8, 8S, and UNI) was used. The ranges were quantized in 1- and 2-km increments from 0 to 50 km, and the firing tables were used to determine which quadrant elevations resulted in those ranges for those charges. Often there are two valid QE solutions to reach a range at a certain charge. When both high-angle and low-angle solutions existed, only the low angle was used; this choice reflects the general policy of limiting the flight time of the projectile to minimize its vulnerability. The remaining variables in the 3DOF model (temperature, tube wear, met conditions, etc) were set to nominal for all flights.

The resulting conditions for the AFAS database are in appendix A. A summary of the conditions is shown in table 2, which shows, for example, that there are 26 different ways for an M483A1 to hit a short-range target. This table is further modified by the doctrine constraints (for example, the M864 is only fired long range). The modified distribution is referred to here as the uniform flight distribution (table 3), since there is no information as to how likely each flight is to be used.

The combination of projectile and range category (short, medium, and long) is considered a class of flights. In order to create a set of flights that represent the AFAS usage distribution from the uniform distribution of flights, we determined a weighting factor and applied it to each class of flights, so that in the weighted set of flights, the percentage of all flights in a class will agree with the AFAS distribution. The weighting factors were determined by trial and error to approximate the AFAS distribution; see table 4.

For example, the 26 flights that make up the class of short-range firings of the M483A1 would be represented eight times each in the weighted database. That class will then make up 208/936, or 22.2 percent of the total usage. This corresponds to 13/60, or 21.7 percent of the original AFAS distribution.

Table 2. Summary of possible conditions based on firing tables.

Projectile	Firings according to range		
	Short	Medium	Long
M483A1	26	15	1
M795	27	16	1
M864	11	18	8
M549A1	9	20	9
M898	26	15	1

Table 3. Uniform flight distribution.

Projectile	Firings according to range		
	Short	Medium	Long
M483A1	26	15	—
M795	27	16	—
M864	—	—	8
M549A1	—	—	9
M898	26	15	—

Table 4. Weighted flight distribution.

Projectile	AFAS distribution			Firing tables distribution			Weight factor no. in class		
	S	M	L	S	M	L	S	M	L
M483A1	13	12	—	26	15	—	8 208	12 180	—
M795	13	5	3	27	16	—	8 216	5 80	45 45
M864	—	—	5	—	—	8	—	—	9 72
M549A1	—	—	2	—	—	9	—	—	3 27
M898	5	2	—	26	15	—	3 78	2 30	—
	Total = 60			Total = 142			Total flights = 936		

4. Normalized Flight Time

So that the results, based on flights of differing lengths, can be compared, the flight times are normalized and presented as a percentage of the total flight. Twenty increments are used. For example, if a flight is 58 s long, then the parameters of interest (its position and velocity) are calculated every 2.9 s. This information is then used to calculate the best GDOP at each time increment, and the resulting GDOP's are stored in the 20 corresponding bins. At the end of the Monte Carlo analysis, there will be a distribution of GDOP's for each 5 percent of the "typical" flight. This allows separate portions of flight to be considered. Figures 8 and 9 illustrate how the use of normalized flight time allows comparison of flights. The velocity vector as well as the position of the projectile was required so that one could determine the attitude of the projectile and hence the attitude of its axial antenna nulls.

Figure 8. Short-, medium-, and long-range flights.

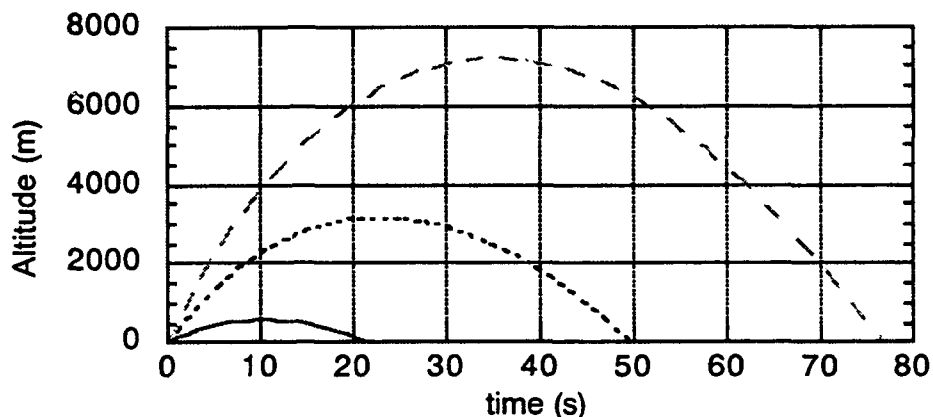
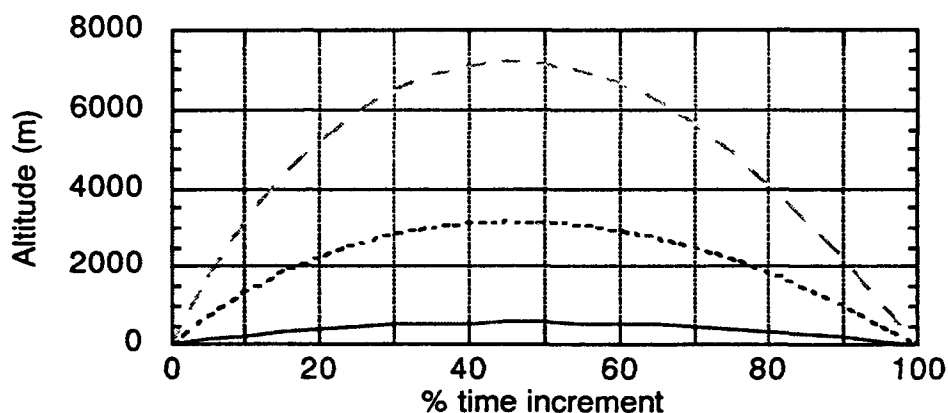

Figure 9. Three flights with normalized flight time.



5. Baseline Results

Before the results of a large number of trials on the flight mission database are examined, it is informative to perform a series of baseline calculations to determine the "performance" of our satellite model when unperturbed by antenna nulls.

The first baseline calculation consisted of determining the lowest GDOP of all satellite combinations for 10,000 trials for random locations on the globe, with the fixed variable being a horizon mask angle. Table 5 shows these results. The horizon mask angle is the elevation above the horizon below which a satellite is considered masked by the terrain. For example, in table 5, the value of 2.509 for 50-percent time and 0° mask angle indicates that 50 percent of the time, or for half the Monte Carlo trials, the GDOP was 2.509 or better (smaller). The result agrees closely with the advertised figure of merit of a GDOP of 6.0 for 90 percent of the time with the full constellation intact and a 5° mask angle.

Table 5. Baseline GDOP calculation.

Percentage of time	GDOP according to horizon mask angle				
	0°	5°	10°	15°	20°
50	2.509	2.821	3.323	3.856	4.656
80	3.472	3.997	4.653	5.618	6.976
90	5.047	5.934	6.939	8.092	10.876

6. Monte Carlo Repeatability

My colleague Leng Sim and I conducted the baseline experiment three times under the same conditions to determine the variability of the results. Since the values are arrived at through many combinations of randomly selected parameters, one would not expect the same result for each set of trials, unless an extremely large number of trials was conducted. For our sample size of 10,000 trials, we found that the results at the 50th, 80th, 90th, and 95th percentiles varied from experiment to experiment by less than 5 percent.

7. Baseline Case with Fixed Antenna Null

An extension of the baseline case is the case of a fixed antenna null pointing at the sky (see fig. 10). A surprisingly large null can be tolerated. This is because the best geometry giving the lowest GDOP occurs when the satellites are separated in the sky, and not close together within a null. Given that there is a 5-percent variability in the answers, then there is little difference at all for small antenna nulls (see table 6).

Figure 10. Fixed antenna nulls used in baseline calculations.

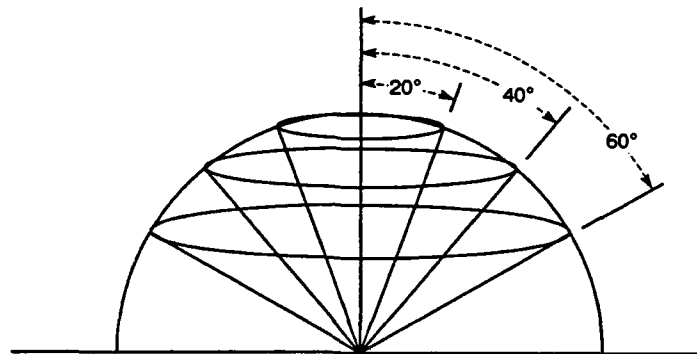

Table 6. Baseline case of various size antenna nulls.

Percentage of time	GDOP at various null sizes (half angle)						
	0°	10°	20°	30°	40°	50°	60°
50	2.831	2.836	2.838	2.854	2.910	2.980	3.508
80	3.992	3.923	3.986	4.022	4.141	4.778	N/A
90	5.919	5.633	5.896	5.963	6.362	14.691	N/A

N/A indicates less than four satellites visible.

As a final baseline case, a fixed null of 20° half angle was allowed to point at various angles with respect to the normal direction. Figure 11 illustrates this case, and table 7 gives results. Again, given that there is a 5-percent inaccuracy in the results, there is no detectable difference for the various orientations.

Figure 11. Null (20°) at two orientations for baseline calculation.

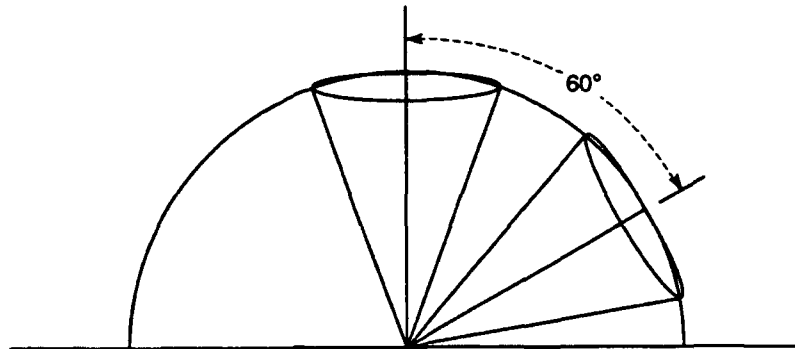

Table 7. Baseline case of 20° null at different orientations.

Percentage of time	GDOP at null offset from normal direction				
	0° (up)	15°	30°	45°	60°
50	2.839	2.843	2.845	2.839	2.844
80	3.986	3.984	4.009	4.003	3.991
90	5.787	5.898	5.903	5.903	5.954

8. Monte Carlo Results

The Monte Carlo simulation was conducted for a 5° horizon mask angle, with the primary constellation of 24 satellites. We used various combinations of projectile antenna null sizes to show how the system performance degrades depending on the null size. A full table of results may be found in appendix B.

We may arbitrarily choose a 90th-percentile GDOP of 7.0 as a cutoff as an illustration.

For a system with fairly large nulls of 40° in the front and rear, there are no restrictions. The calculated GDOP was less than 7.0 for 90 percent of the Monte Carlo trials. For a system with a 60° null in the front and a 10° null in the rear (which is worse than the prototype antenna flown on an artillery projectile in a translator test program), the GDOP is unacceptable at the beginning of flight, but improves to a usable level after 30 percent of the normalized flight time has expired. Even for the worst combination tested, that of a 60° forward null and a 40° rear null, the GDOP was less than 10 for the final 40 percent of the flight.

9. Conclusions

The baseline calculations show that the Global Positioning System, because of the satellite geometry, is very tolerant of a null in the receiver antenna pattern. It is somewhat less tolerant of horizon masking, which would not be a problem in an airborne application. These observations make sense when one considers the tetrahedral volume that the geometric dilution of precision is based upon.

Overall, the artillery system was found to perform surprisingly well with substantial antenna nulls. As expected, the performance was better at the end of flight for cases with large forward nulls, when the null would be pointed at the ground.

Appendix A. Firing Conditions for Artillery Missions Used in Monte Carlo Analysis

Tables

	Page
A-1. Projectile M483A1	18
A-2. Projectile M795	18
A-3. Projectile M549	19
A-4. Projectile M864	19
A-5. Projectile M898	20

Appendix A

Tables A-1 to A-5 give quadrant elevations and charge conditions used in the three-degree-of-freedom computer model to generate the trajectory database. These values were extracted from published and preliminary firing tables.

Table A-1. Projectile M483A1.

Range (m)	Quadrant elevation (mils) according to charge							
	4W	5G	5W	6W	7W	8	8R	UNI
8000	602	524	465	356	270			
9000		680	566	416	310			
10000			775	488	356	258		
11000				585	412	295		
12000				790	478	336		
13000					560	383		
14000					680	438	292	
15000						501	325	
16000						578	365	270
17000						690	415	296
18000							470	333
19000							530	370
20000							600	412
21000							705	
22000								510
24000								635
25000								730
26000								
28000								
30000								

short

medium

long

Table A-2. Projectile M795.

Range (m)	Quadrant elevation (mils) according to charge							
	4W	5G	5W	6W	7W	8	8R	UNI
8000	562	500	435	322	226			
9000		660	538	387	274			
10000			745	463	327	215		
11000				559	386	255		
12000				732	453	300		
13000					535	349	210	
14000					650	404	243	
15000						467	279	
16000						541	319	232
17000						636	363	264
18000							411	298
19000							466	336
20000							528	376
21000							602	
22000							704	468
24000								580
26000								748
28000								
30000								

Table A-3. Projectile M549.

Range (m)	Quadrant elevation (mils) according to charge							
	4W	5G	5W	6W	7W	8	8R	UNI
8000								
9000								
10000					221			
11000					254			
12000					290			
13000					331	227		
14000					376	257		
15000					426	291		
16000					481	328		
17000					544	369	235	
18000					618	413	262	
19000					716	461	291	
20000						515	322	240
22000						648	392	290
23000						746		
24000							471	346
26000							564	408
28000							681	474
30000							887	545
32000								620
34000								698
35000								741
36000								
38000								
40000								

Table A-4. Projectile M864.

Range (m)	Quadrant elevation (mils) according to charge							
	4W	5G	5W	6W	7W	8	8R	UNI
8000								
9000					239			
10000					277			
11000					319			
12000					364	234		
13000					414	264		
14000					471	297		
15000					538	333		
16000					618	374	239	
17000					758	418	265	
18000						468	292	
19000						524	321	
20000						589	354	255
21000						671		
22000							425	300
24000							510	360
26000							620	415
28000							838	478
30000								552
32000								640
34000								740
35000								815
36000								
38000								
40000								

Appendix A

Table A-5. Projectile M898.

Range (m)	Quadrant elevation (mils) according to charge							
	4W	5G	5W	6W	7W	8	8R	UNI
8000	602	524	465	356	270			
9000		680	566	416	310			
10000			775	488	356	258		
11000				585	412	295		
12000				790	478	336		
13000					560	383		
14000					680	438	292	
15000						501	325	
16000						578	365	270
17000						690	415	296
18000							470	333
19000							530	370
20000							600	412
21000							705	
22000								510
24000								635
25000								730
26000								
28000								
30000								

Appendix B. Monte Carlo Results: Best Calculated GDOP versus Normalized Flight Time and Antenna Null Conditions

Tables

	Page
B-1. Best GDOP for 50 percent of calculations	22
B-2. Best GDOP for 80 percent of calculations	24
B-3. Best GDOP for 90 percent of calculations	26
B-4. Best GDOP for 95 percent of calculations	28

Appendix B

The values in table B-1 correspond to the best calculated GDOP at the given percentage of flight increment for the specified antenna null angles. For the Monte Carlo analysis of 10,000 trials, 50 percent of the trials resulted in a calculated GDOP that was better (smaller) than that in the table.

Table B-1. Best GDOP for 50 percent of calculations.

Antenna null (°)		50% GDOP Monte Carlo results according to normalized flight time									
front	rear	5%	10%	15%	20%	25%	30%	35%	40%	45%	50%
0	0	2.84	2.84	2.84	2.84	2.84	2.84	2.84	2.84	2.84	2.84
10	0	2.85	2.84	2.84	2.84	2.84	2.84	2.84	2.84	2.84	2.84
20	0	2.84	2.84	2.84	2.84	2.84	2.83	2.83	2.83	2.83	2.82
30	0	2.89	2.89	2.88	2.88	2.88	2.87	2.87	2.87	2.86	2.86
40	0	2.91	2.91	2.90	2.90	2.89	2.89	2.88	2.88	2.87	2.86
50	0	2.97	2.96	2.95	2.95	2.94	2.93	2.92	2.91	2.90	2.89
60	0	3.04	3.02	3.01	3.00	2.98	2.98	2.96	2.95	2.94	2.93
0	10	2.83	2.83	2.83	2.83	2.83	2.83	2.83	2.83	2.83	2.83
10	10	2.83	2.83	2.83	2.83	2.83	2.83	2.83	2.83	2.83	2.83
20	10	2.87	2.86	2.86	2.86	2.86	2.85	2.85	2.85	2.85	2.85
30	10	2.88	2.88	2.87	2.87	2.87	2.86	2.86	2.85	2.85	2.85
40	10	2.82	2.82	2.82	2.82	2.82	2.82	2.82	2.82	2.82	2.83
50	10	2.95	2.95	2.94	2.94	2.93	2.92	2.91	2.90	2.89	2.89
60	10	3.03	3.01	3.00	2.99	2.98	2.96	2.95	2.94	2.93	2.93
0	20	2.82	2.82	2.82	2.82	2.82	2.82	2.82	2.83	2.83	2.83
10	20	2.84	2.84	2.84	2.84	2.84	2.84	2.84	2.84	2.84	2.84
20	20	2.85	2.85	2.85	2.85	2.84	2.84	2.84	2.84	2.84	2.84
30	20	2.88	2.88	2.87	2.87	2.86	2.86	2.86	2.85	2.85	2.85
40	20	2.89	2.89	2.89	2.88	2.88	2.88	2.87	2.87	2.86	2.86
50	20	2.96	2.95	2.94	2.94	2.93	2.92	2.92	2.91	2.91	2.90
60	20	3.04	3.02	3.01	3.00	2.99	2.98	2.97	2.96	2.96	2.95
0	30	2.84	2.84	2.84	2.84	2.84	2.84	2.84	2.85	2.85	2.86
10	30	2.83	2.83	2.83	2.83	2.83	2.83	2.83	2.83	2.83	2.84
20	30	2.87	2.87	2.87	2.87	2.87	2.87	2.86	2.87	2.87	2.87
30	30	2.88	2.88	2.88	2.88	2.88	2.88	2.88	2.88	2.87	2.87
40	30	2.92	2.91	2.91	2.91	2.91	2.91	2.90	2.90	2.90	2.90
50	30	2.96	2.96	2.95	2.95	2.95	2.94	2.94	2.94	2.94	2.93
60	30	3.02	3.01	3.01	3.00	2.99	2.98	2.98	2.98	2.97	2.96
0	40	2.83	2.83	2.83	2.84	2.84	2.84	2.85	2.86	2.86	2.87
10	40	2.83	2.83	2.84	2.84	2.84	2.84	2.85	2.85	2.86	2.86
20	40	2.85	2.85	2.85	2.85	2.86	2.86	2.86	2.86	2.87	2.87
30	40	2.88	2.88	2.88	2.88	2.89	2.89	2.89	2.89	2.90	2.90
40	40	2.90	2.90	2.90	2.90	2.90	2.90	2.90	2.91	2.91	2.90
50	40	2.97	2.97	2.97	2.97	2.97	2.97	2.97	2.97	2.97	2.97
60	40	3.08	3.07	3.07	3.07	3.06	3.06	3.05	3.05	3.04	3.05

Table B-1 (cont'd). Best GDOP for 50 percent of calculations.

Antenna null (°)		50% GDOP Monte Carlo results according to normalized flight time									
front	rear	55%	60%	65%	70%	75%	80%	85%	90%	95%	100%
0	0	2.84	2.84	2.84	2.84	2.84	2.84	2.84	2.84	2.84	2.84
10	0	2.84	2.84	2.84	2.84	2.84	2.84	2.84	2.84	2.84	2.84
20	0	2.82	2.82	2.82	2.82	2.82	2.82	2.82	2.82	2.82	2.82
30	0	2.85	2.85	2.85	2.85	2.85	2.85	2.85	2.85	2.85	2.85
40	0	2.86	2.85	2.84	2.84	2.84	2.84	2.84	2.83	2.83	2.83
50	0	2.88	2.88	2.87	2.86	2.86	2.85	2.85	2.84	2.84	2.84
60	0	2.92	2.91	2.90	2.89	2.88	2.87	2.87	2.86	2.86	2.86
0	10	2.83	2.83	2.83	2.83	2.83	2.84	2.84	2.84	2.84	2.84
10	10	2.83	2.83	2.83	2.83	2.83	2.83	2.83	2.83	2.83	2.83
20	10	2.85	2.85	2.85	2.85	2.85	2.85	2.85	2.85	2.85	2.85
30	10	2.84	2.84	2.84	2.84	2.84	2.84	2.84	2.84	2.84	2.84
40	10	2.83	2.83	2.83	2.83	2.83	2.83	2.83	2.83	2.83	2.83
50	10	2.88	2.87	2.86	2.86	2.85	2.85	2.84	2.84	2.84	2.83
60	10	2.92	2.91	2.90	2.89	2.88	2.87	2.87	2.86	2.86	2.85
0	20	2.83	2.84	2.84	2.84	2.85	2.85	2.85	2.85	2.85	2.85
10	20	2.84	2.85	2.85	2.85	2.86	2.86	2.86	2.86	2.86	2.86
20	20	2.84	2.84	2.85	2.85	2.85	2.85	2.85	2.85	2.86	2.86
30	20	2.85	2.85	2.85	2.85	2.85	2.85	2.85	2.85	2.85	2.85
40	20	2.86	2.85	2.85	2.85	2.84	2.84	2.84	2.84	2.84	2.84
50	20	2.90	2.89	2.88	2.88	2.88	2.88	2.87	2.87	2.87	2.87
60	20	2.94	2.93	2.93	2.92	2.91	2.90	2.89	2.89	2.88	2.87
0	30	2.86	2.87	2.87	2.88	2.88	2.89	2.89	2.89	2.89	2.89
10	30	2.84	2.85	2.85	2.86	2.86	2.86	2.86	2.87	2.87	2.87
20	30	2.87	2.88	2.89	2.89	2.89	2.89	2.90	2.90	2.90	2.90
30	30	2.87	2.87	2.88	2.88	2.88	2.89	2.89	2.89	2.89	2.89
40	30	2.90	2.90	2.90	2.90	2.90	2.90	2.90	2.90	2.90	2.89
50	30	2.92	2.92	2.91	2.91	2.91	2.90	2.90	2.90	2.90	2.89
60	30	2.96	2.96	2.95	2.94	2.94	2.93	2.92	2.91	2.90	2.90
0	40	2.87	2.88	2.89	2.90	2.90	2.90	2.91	2.91	2.92	2.92
10	40	2.87	2.88	2.88	2.90	2.90	2.90	2.91	2.91	2.91	2.91
20	40	2.87	2.88	2.89	2.90	2.90	2.90	2.91	2.91	2.91	2.91
30	40	2.90	2.90	2.91	2.91	2.92	2.92	2.93	2.93	2.93	2.93
40	40	2.91	2.91	2.91	2.91	2.91	2.91	2.92	2.92	2.92	2.92
50	40	2.96	2.96	2.96	2.95	2.95	2.95	2.95	2.95	2.95	2.94
60	40	3.04	3.03	3.02	3.01	3.00	3.00	2.98	2.97	2.97	2.96

Appendix B

The values in table B-2 correspond to the best calculated GDOP at the given percentage of flight increment for the specified antenna null angles. For the Monte Carlo analysis of 10,000 trials, 80 percent of the trials resulted in a calculated GDOP that was better (smaller) than that in the table.

Table B-2. Best GDOP for 80 percent of calculations.

Antenna null (°)		80% GDOP Monte Carlo results according to normalized flight time									
front	rear	5%	10%	15%	20%	25%	30%	35%	40%	45%	50%
0	0	3.95	3.95	3.95	3.95	3.95	3.95	3.95	3.95	3.95	3.95
10	0	4.04	4.04	4.04	4.04	4.04	4.04	4.04	4.04	4.04	4.04
20	0	3.99	3.99	3.99	3.98	3.98	3.98	3.98	3.97	3.97	3.96
30	0	4.07	4.07	4.06	4.05	4.05	4.04	4.03	4.02	4.01	4.01
40	0	4.12	4.12	4.11	4.09	4.08	4.06	4.04	4.03	4.01	4.00
50	0	4.28	4.25	4.22	4.17	4.14	4.12	4.10	4.08	4.06	4.05
60	0	4.91	4.77	4.65	4.53	4.43	4.35	4.30	4.25	4.21	4.18
0	10	4.01	4.01	4.01	4.01	4.01	4.01	4.01	4.01	4.01	4.02
10	10	3.99	3.99	3.99	3.99	3.99	3.99	3.99	3.99	3.99	3.99
20	10	4.09	4.09	4.09	4.09	4.08	4.07	4.07	4.07	4.06	4.05
30	10	4.06	4.06	4.06	4.05	4.04	4.04	4.03	4.03	4.02	4.02
40	10	3.98	3.98	3.98	3.98	3.98	3.98	3.98	3.98	3.98	3.98
50	10	4.30	4.26	4.24	4.20	4.18	4.14	4.11	4.08	4.05	4.04
60	10	4.90	4.75	4.61	4.51	4.41	4.33	4.27	4.23	4.19	4.16
0	20	3.94	3.94	3.94	3.94	3.94	3.94	3.94	3.95	3.95	3.96
10	20	4.03	4.03	4.03	4.03	4.03	4.03	4.03	4.03	4.04	4.04
20	20	4.02	4.02	4.02	4.02	4.01	4.01	4.01	4.01	4.01	4.01
30	20	4.02	4.02	4.02	4.01	4.01	4.00	3.99	3.99	3.99	3.98
40	20	4.08	4.05	4.03	4.02	4.01	4.01	4.00	3.99	3.99	3.99
50	20	4.22	4.20	4.18	4.17	4.15	4.13	4.11	4.10	4.08	4.07
60	20	4.89	4.77	4.62	4.53	4.42	4.36	4.31	4.26	4.23	4.21
0	30	4.01	4.01	4.01	4.01	4.02	4.02	4.02	4.03	4.04	4.05
10	30	3.98	3.98	3.98	3.98	3.98	3.99	3.99	4.00	4.00	4.02
20	30	4.05	4.05	4.05	4.05	4.05	4.05	4.05	4.06	4.06	4.06
30	30	4.07	4.07	4.07	4.06	4.06	4.06	4.06	4.06	4.05	4.05
40	30	4.13	4.12	4.11	4.11	4.10	4.09	4.08	4.06	4.06	4.06
50	30	4.28	4.26	4.23	4.21	4.20	4.18	4.17	4.16	4.13	4.13
60	30	4.89	4.73	4.65	4.54	4.46	4.40	4.38	4.39	4.33	4.29
0	40	3.98	3.98	3.98	3.98	3.98	3.99	4.00	4.01	4.01	4.03
10	40	3.98	3.98	3.98	3.99	3.99	3.99	3.99	4.00	4.01	4.02
20	40	3.99	4.00	4.00	4.00	4.01	4.01	4.01	4.02	4.02	4.03
30	40	4.06	4.06	4.05	4.06	4.06	4.06	4.06	4.06	4.06	4.06
40	40	4.11	4.10	4.09	4.10	4.11	4.11	4.11	4.11	4.13	4.14
50	40	4.43	4.42	4.40	4.39	4.40	4.39	4.37	4.39	4.38	4.36
60	40	5.53	5.32	5.25	5.21	5.11	5.08	4.97	4.92	4.88	4.81

Table B-2 (cont'd). Best GDOP for 80 percent of calculations.

Antenna 100% GDOP Monte Carlo results according to normalized flight time

front	rear	55%	65%	70%	75%	80%	85%	90%	95%	100%
0	0	3.95	3.95	3.95	3.95	3.95	3.95	3.95	3.95	3.95
10	0	4.04	4.04	4.04	4.04	4.04	4.04	4.04	4.04	4.04
20	0	3.96	3.96	3.96	3.96	3.96	3.96	3.96	3.96	3.96
30	0	4.01	4.00	4.00	4.00	4.00	4.00	3.99	3.99	3.99
40	0	4.00	3.99	3.98	3.98	3.97	3.97	3.96	3.96	3.96
50	0	4.02	4.01	4.00	3.99	3.99	3.98	3.97	3.97	3.96
60	0	4.15	4.12	4.10	4.08	4.07	4.05	4.05	4.04	4.03
0	10	4.02	4.02	4.02	4.02	4.02	4.02	4.02	4.02	4.02
10	10	3.99	3.99	4.00	4.00	4.00	4.00	4.00	4.00	4.00
20	10	4.06	4.06	4.06	4.06	4.06	4.06	4.06	4.06	4.06
30	10	4.02	4.02	4.02	4.02	4.02	4.02	4.02	4.02	4.02
40	10	3.98	3.98	3.98	3.98	3.98	3.98	3.98	3.98	3.98
50	10	4.03	4.02	4.02	4.01	4.00	4.00	3.99	3.98	3.98
60	10	4.15	4.13	4.11	4.09	4.07	4.05	4.05	4.04	4.02
0	20	3.96	3.97	3.97	3.97	3.97	3.97	3.98	3.97	3.98
10	20	4.04	4.04	4.05	4.06	4.07	4.07	4.07	4.08	4.09
20	20	4.01	4.02	4.02	4.02	4.03	4.03	4.04	4.04	4.04
30	20	3.98	3.98	3.98	3.98	3.98	3.98	3.98	3.98	3.98
40	20	3.98	3.98	3.97	3.97	3.97	3.97	3.97	3.97	3.97
50	20	4.06	4.05	4.04	4.03	4.03	4.03	4.03	4.01	4.01
60	20	4.19	4.18	4.16	4.15	4.14	4.12	4.11	4.10	4.09
0	30	4.06	4.06	4.06	4.08	4.08	4.09	4.10	4.11	4.11
10	30	4.02	4.04	4.04	4.05	4.06	4.07	4.07	4.07	4.06
20	30	4.07	4.08	4.08	4.10	4.12	4.12	4.13	4.13	4.13
30	30	4.04	4.05	4.04	4.04	4.05	4.05	4.06	4.07	4.06
40	30	4.06	4.06	4.06	4.07	4.07	4.07	4.07	4.07	4.07
50	30	4.13	4.14	4.13	4.13	4.11	4.09	4.08	4.07	4.06
60	30	4.28	4.27	4.25	4.21	4.19	4.17	4.14	4.12	4.11
0	40	4.05	4.06	4.08	4.10	4.13	4.14	4.15	4.17	4.18
10	40	4.04	4.05	4.06	4.07	4.09	4.10	4.12	4.13	4.14
20	40	4.03	4.03	4.06	4.07	4.10	4.12	4.14	4.15	4.16
30	40	4.08	4.10	4.10	4.11	4.11	4.12	4.13	4.14	4.15
40	40	4.14	4.13	4.13	4.14	4.15	4.16	4.16	4.17	4.18
50	40	4.35	4.36	4.35	4.32	4.31	4.32	4.31	4.30	4.30
60	40	4.72	4.66	4.63	4.60	4.57	4.49	4.44	4.39	4.35

Appendix B

The values in table B-3 correspond to the best calculated GDOP at the given percentage of flight increment for the specified antenna null angles. For the Monte Carlo analysis of 10,000 trials, 90 percent of the trials resulted in a calculated GDOP that was better (smaller) than that in the table.

Table B-3. Best GDOP for 90 percent of calculations.

Antenna null (°)		90% GDOP Monte Carlo results according to normalized flight time									
frt	rear	5%	10%	15%	20%	25%	30%	35%	40%	45%	50%
0	0	5.74	5.74	5.74	5.74	5.74	5.74	5.74	5.74	5.74	5.74
10	0	5.96	5.96	5.97	5.97	5.97	5.97	5.97	5.97	5.96	5.96
20	0	5.71	5.72	5.72	5.72	5.72	5.72	5.71	5.71	5.70	5.70
30	0	6.03	6.01	6.01	6.01	5.99	5.98	5.97	5.95	5.95	5.95
40	0	6.20	6.19	6.17	6.12	6.10	6.05	6.02	6.00	5.97	5.94
50	0	6.59	6.46	6.33	6.26	6.21	6.07	6.03	5.95	5.90	5.87
60	0	16.06	12.27	10.04	8.64	7.59	7.02	6.56	6.35	6.20	6.08
0	10	6.12	6.12	6.12	6.12	6.12	6.12	6.12	6.12	6.13	6.13
10	10	5.74	5.74	5.74	5.76	5.74	5.74	5.74	5.74	5.74	5.74
20	10	5.99	5.99	5.99	5.98	5.98	5.96	5.95	5.95	5.95	5.95
30	10	6.06	6.06	6.05	6.03	6.03	6.02	6.01	6.00	5.99	5.99
40	10	5.74	5.74	5.74	5.74	5.74	5.74	5.74	5.74	5.74	5.74
50	10	6.63	6.54	6.38	6.28	6.15	6.06	5.97	5.91	5.88	5.85
60	10	15.16	11.64	9.58	8.49	7.54	7.12	6.77	6.57	6.40	6.30
0	20	5.91	5.91	5.91	5.91	5.91	5.91	5.91	5.92	5.92	5.93
10	20	5.98	5.98	5.98	5.98	5.98	5.98	5.98	5.98	5.98	5.96
20	20	5.87	5.87	5.87	5.87	5.87	5.88	5.89	5.89	5.90	5.90
30	20	5.86	5.86	5.84	5.84	5.83	5.81	5.80	5.81	5.81	5.81
40	20	6.05	6.02	6.00	5.95	5.85	5.83	5.82	5.77	5.78	5.80
50	20	6.70	6.47	6.37	6.31	6.20	6.17	6.12	6.07	6.03	6.04
60	20	15.15	11.85	9.63	8.35	7.42	6.99	6.71	6.39	6.30	6.22
0	30	5.84	5.85	5.85	5.85	5.85	5.85	5.87	5.87	5.88	5.89
10	30	5.88	5.88	5.88	5.87	5.88	5.88	5.88	5.89	5.89	5.89
20	30	5.93	5.93	5.96	5.94	5.94	5.92	5.93	5.92	5.92	5.93
30	30	6.02	6.00	6.00	5.99	5.99	5.98	5.97	5.97	5.98	5.97
40	30	6.15	6.16	6.14	6.14	6.13	6.14	6.14	6.12	6.10	6.07
50	30	6.91	6.71	6.57	6.44	6.35	6.32	6.23	6.19	6.14	6.13
60	30	16.04	12.39	10.89	9.32	8.48	8.04	7.95	7.98	7.59	7.26
0	40	5.78	5.78	5.79	5.79	5.79	5.80	5.80	5.81	5.82	5.82
10	40	5.98	5.98	5.98	6.00	6.01	6.02	6.02	6.01	6.03	6.03
20	40	5.97	5.97	5.98	5.97	5.97	5.99	6.00	6.01	6.00	6.02
30	40	6.26	6.26	6.27	6.27	6.27	6.27	6.26	6.25	6.24	6.24
40	40	6.22	6.22	6.17	6.18	6.16	6.17	6.18	6.17	6.17	6.18
50	40	7.66	7.60	7.40	7.38	7.30	7.24	7.19	7.22	7.30	7.12
60	40	33.80	23.38	19.62	17.71	16.10	15.59	13.64	12.90	12.32	11.68

Table B-3 (cont'd). Best GDOP for 90 percent of calculations.

Antenna null (°)		90% GDOP Monte Carlo results according to normalized flight time									
front	rear	55%	60%	65%	70%	75%	80%	85%	90%	95%	100%
0	0	5.74	5.74	5.74	5.74	5.74	5.74	5.74	5.74	5.74	5.74
10	0	5.96	5.96	5.96	5.96	5.96	5.96	5.96	5.96	5.96	5.96
20	0	5.70	5.70	5.70	5.70	5.70	5.70	5.70	5.70	5.70	5.70
30	0	5.93	5.90	5.90	5.90	5.90	5.90	5.90	5.90	5.90	5.90
40	0	5.94	5.92	5.92	5.91	5.88	5.88	5.88	5.88	5.87	5.86
50	0	5.83	5.81	5.80	5.79	5.79	5.78	5.78	5.78	5.78	5.75
60	0	6.01	5.96	5.94	5.89	5.88	5.87	5.86	5.85	5.83	5.82
0	10	6.14	6.15	6.15	6.15	6.15	6.15	6.14	6.14	6.13	6.13
10	10	5.74	5.74	5.74	5.74	5.75	5.76	5.76	5.76	5.75	5.74
20	10	5.95	5.95	5.95	5.95	5.95	5.95	5.95	5.95	5.95	5.95
30	10	5.99	5.99	5.98	5.98	5.97	5.97	5.96	5.97	5.97	5.97
40	10	5.74	5.77	5.77	5.77	5.76	5.77	5.77	5.76	5.77	5.77
50	10	5.84	5.82	5.79	5.77	5.77	5.76	5.72	5.71	5.71	5.70
60	10	6.28	6.27	6.24	6.19	6.19	6.14	6.10	6.04	6.03	6.02
0	20	5.93	5.93	5.93	5.93	5.93	5.93	5.93	5.93	5.93	5.93
10	20	5.98	5.98	5.98	5.99	5.99	6.00	6.03	6.01	6.02	6.03
20	20	5.91	5.90	5.90	5.90	5.90	5.90	5.88	5.89	5.88	5.88
30	20	5.82	5.81	5.81	5.81	5.82	5.82	5.84	5.82	5.84	5.82
40	20	5.77	5.76	5.75	5.74	5.76	5.76	5.76	5.75	5.74	5.72
50	20	6.03	5.99	5.94	5.94	5.90	5.87	5.88	5.85	5.84	5.84
60	20	6.15	6.11	6.04	5.99	5.98	5.92	5.87	5.87	5.85	5.85
0	30	5.89	5.90	5.94	5.95	5.97	5.97	5.96	5.95	5.96	5.98
10	30	5.90	5.91	5.92	5.95	5.97	5.97	5.97	5.97	5.97	5.97
20	30	5.93	5.95	5.95	5.96	6.01	6.03	6.05	6.06	6.08	6.09
30	30	5.98	5.98	5.97	5.98	6.00	6.01	6.01	6.03	6.03	6.04
40	30	6.09	6.07	6.06	6.06	6.12	6.08	6.06	6.06	6.06	6.07
50	30	6.14	6.14	6.12	6.08	6.08	6.03	6.00	6.03	6.02	5.98
60	30	7.21	6.96	6.72	6.60	6.50	6.42	6.34	6.24	6.17	6.13
0	40	5.83	5.87	5.90	5.94	5.97	6.03	6.09	6.13	6.19	6.18
10	40	6.03	6.05	6.09	6.14	6.16	6.25	6.31	6.33	6.33	6.35
20	40	6.01	6.02	6.05	6.12	6.21	6.26	6.29	6.33	6.35	6.34
30	40	6.28	6.30	6.31	6.32	6.34	6.40	6.42	6.47	6.48	6.49
40	40	6.15	6.16	6.18	6.17	6.20	6.22	6.26	6.37	6.42	6.52
50	40	7.00	7.16	7.10	6.97	6.97	6.97	6.91	6.91	6.88	6.79
60	40	10.79	10.15	9.51	9.42	8.87	8.47	8.25	7.93	7.65	7.39

Appendix B

The values in table B-4 correspond to the best calculated GDOP at the given percentage of flight increment for the specified antenna null angles. For the Monte Carlo analysis of 10,000 trials, 95 percent of the trials resulted in a calculated GDOP that was better (smaller) than that in the table.

Table B-4. Best GDOP for 95 percent of calculations.

Antenna null (°)		95% GDOP Monte Carlo results according to normalized flight time									
front	rear	5%	10%	15%	20%	25%	30%	35%	40%	45%	50%
0	0	12.20	12.20	12.20	12.20	12.20	12.20	12.20	12.20	12.20	12.20
10	0	13.60	13.60	13.60	13.54	13.54	13.54	13.54	13.54	13.54	13.54
20	0	11.42	11.42	11.42	11.42	11.42	11.42	11.42	11.41	11.41	11.41
30	0	12.95	12.95	12.95	12.87	12.87	12.83	12.81	12.78	12.78	12.74
40	0	12.75	12.72	12.61	12.21	12.16	12.07	12.05	12.03	11.99	11.99
50	0	16.31	15.05	13.99	13.05	12.42	11.81	11.70	11.58	11.19	11.10
60	0	N/A	99.99	99.99	42.64	29.59	21.95	17.93	16.05	14.53	13.70
0	10	13.45	13.45	13.45	13.45	13.45	13.45	13.45	13.45	13.45	13.45
10	10	12.54	12.54	12.67	12.67	12.67	12.67	12.67	12.54	12.54	12.67
20	10	12.80	12.81	12.81	12.81	12.80	12.80	12.80	12.80	12.80	12.79
30	10	12.47	12.53	12.44	12.44	12.44	12.44	12.44	12.44	12.44	12.44
40	10	10.97	10.97	10.97	10.97	10.97	10.97	10.97	10.97	10.97	10.97
50	10	18.48	17.12	15.98	15.14	14.15	13.23	12.39	11.92	11.75	11.70
60	10	N/A	99.99	69.79	38.89	25.85	20.09	17.68	15.82	14.60	14.24
0	20	12.07	12.07	12.07	12.07	12.07	12.07	12.12	12.12	12.12	12.12
10	20	12.94	12.94	12.94	12.94	12.94	12.94	12.94	12.94	12.94	12.94
20	20	12.94	12.94	12.94	12.94	12.94	12.94	12.94	12.94	12.96	12.95
30	20	11.56	11.56	11.54	11.52	11.40	11.40	11.39	11.36	11.35	11.36
40	20	13.90	13.81	13.47	13.26	13.02	12.88	12.78	12.69	12.74	12.68
50	20	16.24	14.84	14.04	13.50	12.72	12.51	12.21	12.21	12.12	12.15
60	20	N/A	N/A	99.99	38.60	24.59	20.72	18.37	15.98	14.67	14.27
0	30	11.88	11.88	11.88	11.88	11.88	11.89	11.98	11.98	11.99	11.99
10	30	11.52	11.52	11.52	11.52	11.52	11.52	11.55	11.55	11.55	11.52
20	30	11.67	11.67	11.67	11.67	11.74	11.80	11.74	11.74	11.66	11.63
30	30	12.15	12.09	12.15	12.22	12.31	12.24	12.33	12.24	12.31	12.31
40	30	12.34	12.39	12.40	12.39	12.39	12.34	12.35	12.30	12.28	12.35
50	30	18.14	17.16	16.18	14.83	14.17	14.00	13.24	13.16	13.17	13.12
60	30	N/A	N/A	99.99	73.46	42.09	34.27	33.00	32.83	25.68	21.95
0	40	11.43	11.43	11.43	11.43	11.49	11.49	11.49	11.51	11.56	11.56
10	40	11.92	11.92	11.92	11.92	11.92	11.95	11.95	11.95	11.97	11.99
20	40	12.11	12.11	12.14	12.14	12.15	12.15	12.24	12.39	12.40	12.44
30	40	12.94	12.88	12.88	12.88	12.94	12.88	12.86	12.86	12.88	12.94
40	40	13.55	13.54	13.35	13.49	13.55	13.56	13.70	13.79	13.56	13.56
50	40	22.24	21.62	19.63	19.27	18.98	18.68	18.02	18.42	18.97	17.87
60	40	N/A	N/A	N/A	N/A	N/A	N/A	N/A	N/A	N/A	99.99

Table B-4 (cont'd). Best GDOP for 95 percent of calculations.

Antenna null (°)		95% GDOP Monte Carlo results according to normalized flight time									
front	rear	55%	60%	65%	70%	75%	80%	85%	90%	95%	100%
0	0	12.20	12.20	12.20	12.20	12.20	12.20	12.20	12.20	12.20	12.20
10	0	13.54	13.54	13.54	13.54	13.54	13.54	13.54	13.54	13.54	13.54
20	0	11.41	11.41	11.41	11.41	11.41	11.41	11.41	11.41	11.41	11.41
30	0	12.74	12.72	12.68	12.68	12.68	12.68	12.68	12.68	12.68	12.68
40	0	11.99	11.99	11.99	11.90	11.89	11.89	11.84	11.85	11.85	11.85
50	0	11.01	11.00	10.80	10.79	10.70	10.69	10.69	10.64	10.64	10.58
60	0	13.38	13.29	13.23	13.10	13.07	13.06	12.95	12.92	12.92	12.91
0	10	13.46	13.46	13.46	13.46	13.46	13.46	13.54	13.46	13.46	13.46
10	10	12.67	12.67	12.67	12.67	12.67	12.54	12.54	12.54	12.54	12.54
20	10	12.79	12.79	12.79	12.80	12.80	12.79	12.79	12.79	12.80	12.80
30	10	12.44	12.42	12.42	12.44	12.48	12.42	12.42	12.42	12.42	12.40
40	10	10.97	10.97	10.97	10.99	10.99	10.99	10.99	10.97	10.97	10.99
50	10	11.69	11.69	11.69	11.60	11.58	11.55	11.47	11.40	11.47	11.40
60	10	14.10	14.11	13.66	13.55	13.55	13.26	13.24	13.12	13.12	13.12
0	20	12.16	12.16	12.16	12.16	12.18	12.19	12.18	12.18	12.16	12.16
10	20	12.94	12.95	12.95	12.95	12.95	12.95	12.95	12.95	12.96	12.95
20	20	12.93	12.93	12.93	12.93	12.94	12.94	12.95	12.95	12.94	12.94
30	20	11.36	11.36	11.36	11.34	11.34	11.29	11.29	11.29	11.29	11.34
40	20	12.47	12.40	12.33	12.40	12.42	12.42	12.42	12.40	12.40	12.33
50	20	12.09	12.04	11.93	11.89	11.83	11.83	11.66	11.65	11.65	11.65
60	20	13.54	13.23	12.80	12.65	12.56	12.35	12.05	11.87	11.88	11.79
0	30	12.02	12.04	12.07	12.11	12.09	12.09	12.11	12.09	12.11	12.07
10	30	11.56	11.56	11.56	11.59	11.68	11.68	11.68	11.69	11.68	11.69
20	30	11.63	11.74	11.75	11.75	11.75	11.75	11.81	11.83	11.83	11.83
30	30	12.31	12.31	12.15	12.11	12.15	12.24	12.15	12.47	12.47	12.24
40	30	12.28	12.21	12.21	12.21	12.20	12.08	12.04	12.04	11.98	11.95
50	30	13.09	13.16	13.08	12.68	12.53	12.46	12.41	12.34	12.22	11.98
60	30	20.93	19.52	17.35	15.85	15.42	14.60	13.95	13.83	13.44	13.21
0	40	11.60	11.77	11.83	11.98	12.41	12.45	12.68	12.96	13.13	13.11
10	40	12.01	12.04	12.08	12.31	12.39	12.51	12.91	13.10	13.15	13.49
20	40	12.40	12.41	12.45	12.76	13.11	13.15	13.38	13.58	13.64	13.64
30	40	13.08	13.08	12.94	12.94	13.15	13.40	13.67	13.91	13.96	14.00
40	40	13.60	13.49	13.56	13.26	13.51	13.60	13.85	14.08	14.29	14.48
50	40	17.10	18.03	17.64	16.92	16.96	16.71	15.79	15.57	15.52	15.04
60	40	99.99	99.99	69.93	73.50	53.62	35.59	30.36	26.56	23.27	20.45

Distribution

Administrator

Defense Technical Information Center
Attn: DTIC-DDA (2 copies)
Cameron Station, Building 5
Alexandria, VA 22304-6145

U.S. Army Research Laboratory

Attn: AMSRL-WT-WB, B. D'Amico
Aberdeen Proving Ground, MD 21005-5066

U.S. Army Research Laboratory

Attn: AMSRL-EP-MD, T. Lucaszek
FT Monmouth, NJ 07703-5601

Office of the Project Manager

Attn: SFAE-ASM-AF-E, T. Kuriata
Picatinny Arsenal, NJ 07428

U.S. Army Research Laboratory

Attn: AMSRL-WT-WF, William Dousa
(5 copies)
Aberdeen Proving Ground, MD 21005-5001

U.S. Army Research Laboratory

Attn: AMSRL-WT-WF, Joe Wall
Aberdeen Proving Ground, MD 21005-5001

Director

U.S. Army ARDEC
Attn: T. Burch
Attn: J. Dyer (5 copies)
Attn: F. Scerbo
Picatinny Arsenal, NJ 07806-5000

Naval Surface Warfare Center

Attn: Code K13, A. Evans (2 copies)
Dahlgren, VA 22448

U.S. Army Research Laboratory

Attn: AMSRL-WT, Directorate Executive

U.S. Army Research Laboratory

Attn: AMSRL-D-C, Legal Office
Attn: AMSRL-OP-CI-AD, Library (. copies)
Attn: AMSRL-OP-CI-AD, Mail & Records
Mgmt
Attn: AMSRL-OP-CI-AD, Tech Pub
Attn: AMSRL-SS-SM, A. Ladas
Attn: AMSRL-SS-SM, B. T. Mays
Attn: AMSRL-SS-SM, G. Wiles (50 copies)
Attn: AMSRL-SS-SM, J. Capps
Attn: AMSRL-SS-SM, L. Sim
Attn: AMSRL-SS-SM, R. Kapoor
Attn: AMSRL-SS-SM, J. Eicke