



**STANDARDIZATION OF AIRCRAFT CONTROL
AND PERFORMANCE SYMBOLOGY ON THE
USAF HEAD-UP DISPLAY**

ARMSTRONG

**Lisa F. Weinstein
William R. Ercoline**

**KRUG Life Sciences, Incorporated
San Antonio Division
P.O. Box 790844
San Antonio, TX 78279-0844**

**SDTIC
ELECTE
JAN 03 1994
A**

Ian McKenzie

**CREW SYSTEMS DIRECTORATE
CREW TECHNOLOGY DIVISION
2504 D Drive, Suite 1
Brooks Air Force Base, TX 78235-5104**

D. Foster Bltton, Lt Col, USAF

**AIR FORCE FLIGHT STANDARDS AGENCY
INSTRUMENT FLIGHT CENTER/FLIGHT OPERATIONS
431 I Street East, Suite 1
Randolph Air Force Base, TX 78180-4334**

Kent K. Gillingham

**CREW SYSTEMS DIRECTORATE
CREW TECHNOLOGY DIVISION
2504 D Drive, Suite 1
Brooks Air Force Base, TX 78235-5104**

LABORATORY

0088
2800
12
86

November 1993

Final Technical Paper for Period January 1990 - January 1993

Approved for public release; distribution is unlimited.

93-31440

**AIR FORCE MATERIEL COMMAND
BROOKS AIR FORCE BASE, TEXAS**

NOTICES

When Government drawings, specifications, or other data are used for any purpose other than in connection with a definitely Government-related procurement, the United States Government incurs no responsibility or any obligation whatsoever. The fact that the Government may have formulated or in any way supplied the said drawings, specifications, or other data, is not to be regarded by implication, or otherwise in any manner construed, as licensing the holder or any other person or corporation; or as conveying any rights or permission to manufacture, use, or sell any patented invention that may in any way be related thereto.

The voluntary, fully informed consent of the subjects used in this research was obtained as required by AFR 169-3.

The Office of Public Affairs has reviewed this report, and it is releasable to the National Technical Information Service, where it will be available to the general public, including foreign nationals.

This report has been reviewed and is approved for publication.



LARRY J. MEEKER, B.S.
Project Scientist



RICHARD L. MILLER, Ph.D.
Chief, Crew Technology Division

REPORT DOCUMENTATION PAGEForm Approved
OMB No. 0704-0188

Public reporting burden for this collection of information is estimated to average 1 hour per response, including the time for reviewing instructions, searching existing data sources, gathering and maintaining the data needed, and completing and reviewing the collection of information. Send comments regarding this burden estimate or any other aspect of this collection of information, including suggestions for reducing this burden, to Washington Headquarters Services, Directorate for Information Operations and Reports, 1215 Jefferson Davis Highway, Suite 1204, Arlington, VA 22202-4302, and to the Office of Management and Budget, Paperwork Reduction Project (0704-0188), Washington, DC 20503.

1. AGENCY USE ONLY (Leave blank)		2. REPORT DATE November 1993	3. REPORT TYPE AND DATES COVERED Final - January 1990 -- January 1993	
4. TITLE AND SUBTITLE Standardization of Aircraft Control and Performance Symbology on the USAF Head-Up Display			5. FUNDING NUMBERS C - F33615-92-C-0018 PE - 62202F PR - 7930 TA - 20 WU - 06	
6. AUTHOR(S) Lisa F. Weinstein William R. Ercoline Ian McKenzie D. Foster Bitton Kent K. Gillingham				
7. PERFORMING ORGANIZATION NAME(S) AND ADDRESS(ES) KRUG Life Sciences, Incorporated San Antonio Division P.O. Box 790644 San Antonio, TX 78279-0644			8. PERFORMING ORGANIZATION REPORT NUMBER	
9. SPONSORING/MONITORING AGENCY NAME(S) AND ADDRESS(ES) Armstrong Laboratory (AFMC) Crew Systems Directorate Crew Technology Division 2504 D Drive, Suite 1 Brooks Air Force Base, TX 78235-5104			10. SPONSORING/MONITORING AGENCY REPORT NUMBER AL/CF-TR-1993-0088	
11. SUPPLEMENTARY NOTES Armstrong Laboratory Technical Monitor: Larry J. Meeker, (210) 536-3337				
12a. DISTRIBUTION/AVAILABILITY STATEMENT Approved for public release; distribution is unlimited.			12b. DISTRIBUTION CODE	
13. ABSTRACT (Maximum 200 words) <p>Researchers and pilots throughout the world continue to examine and debate the utility of the head-up display (HUD) for presenting instrument flight information. Although initially intended for the presentation of landing and weapons delivery information, the HUD has evolved into a flight instrument that researchers and pilots claim is successfully replacing many of the traditional panel instruments. Since the Attitude Awareness Workshop of 1985, the United States Air Force (USAF) has conducted numerous research projects to determine the most effective way to integrate the HUD with the other mission-essential instrument displays. The requirement to use the HUD for instrument flight, as well as a need to determine the optimal configuration of the HUD symbols, has prompted a significant portion of that research. This paper summarizes the research efforts conducted by scientists in the Visual Orientation Laboratory (VOL) and the Flight Motion Effects Branch of the Armstrong Laboratory (AL/CFTF). Suggested standardization guidelines based on empirical findings are discussed, including the use of counter-pointers for airspeed and altitude indicators, vertical and horizontal asymmetry for pitch-ladder configurations, a ghost horizon, analog information for vertical velocity, energy management symbology, and quickening for climb/dive markers.</p>				
14. SUBJECT TERMS Cockpit display design Display symbology Head-up display Flight instruments Spatial disorientation			15. NUMBER OF PAGES 84	
			16. PRICE CODE	
17. SECURITY CLASSIFICATION OF REPORT Unclassified	18. SECURITY CLASSIFICATION OF THIS PAGE Unclassified	19. SECURITY CLASSIFICATION OF ABSTRACT Unclassified	20. LIMITATION OF ABSTRACT UL	

CONTENTS

	Page
Chapter I: Head-up Display	1
Background	1
Technology	3
Chapter II: Research Issues	7
Control Instruments	7
Climb/dive ladder	7
Horizon line	10
Sky pointers	10
FPM/CDM	10
Bank indicator	11
Performance Instruments	11
Airspeed and altitude indicators	11
Vertical velocity indicator	11
Angle-of-attack indicator	12
Navigation Instruments	12
Instrument landing system symbology (raw)	12
Instrument landing system symbology (command)	13
Chapter III: General Test Methods	15
Subjects	15
Apparatus	15
Tasks	15
Unusual Attitude Recovery Task	15
Precision Instrument Control Task	16
Instrument Landing System Approach Task	17

This document contains
blank pages that were
not filmed.

Data Analysis	17
Chapter IV: Element Development Studies	19
Altitude and Airspeed	19
Objective	19
Method	19
Subjects	19
Displays	19
Task	19
Results	20
Summary	22
Articulation/Pitch Reference	22
Objective	22
Method	23
Subjects	23
Displays	23
Task	23
Results	24
Objective Data	24
Subjective Data	24
Summary	24
Ghost Horizon	26
Objective	26
Method	26
Subjects	26
Displays	26
Task	26

Results	27
Summary	28
Vertical Velocity	29
Objective	29
Method	29
Subjects	29
Displays	29
Task	29
Procedure	29
Results	30
Objective Data	31
Subjective Data	32
Summary	32
Energy Management Symbology	34
Objective	34
Method	34
Subjects	34
Displays	34
Task	35
Results	36
Summary	36
Chapter V: Full-Scale Simulation and Inflight Validation	39
Full-Scale Simulation	39
Inflight Validation	39
Beyond the USAF Standard	40
References	43

Appendix A: HUD Symbols and Associated Mechanization	45
Appendix B: Simplified Guide to Quickening	61

LIST OF FIGURES

Figure No.	Page
1. 1955 concept of the future fighter cockpit	2
2. Schematic of the HUD	4
3. A typical composite standard HUD configuration	8
4. The CDM and FPM symbols used in the standard HUD symbology set	11
5. The five HUD altitude and airspeed symbol sets	20
6. Mean altitude error (RMSE) with the 5 altitude and airspeed display formats	21
7. Mean airspeed error (RMSE) with the 5 altitude and airspeed display formats	21
8. Mean subjective ratings for the 5 altitude and airspeed display formats. A rating of "1" was very favorable and "5" was very unfavorable.	22
9. The four HUD configurations illustrating a 145-degree right bank and 40-degree nose-down pitch attitude	23
10. Accuracy data for the four articulation configurations	25
11. Reaction-time data for the four articulation configurations	25
12. The six HUD climb/dive ladder configurations	27
13. The five VVI configuratons shown with the rotating pointer altimeter	30
14. The mean vertical velocity RMSE for the five VVI configurations and the two vertical S tasks	32
15. The RMSE altitude for the five VVI configurations during the straight and level task with perturbations	33
16. The RMSE in bank as a function of VVI configuration	33
17. The four HUD energy management configurations	35

18. The RMS acceleration deviations for the four energy management configurations 36

19. The RMS airspeed deviations for the four energy management configurations 37

20. The RMS AOA deviations for the four energy management configurations 37

21. The RMS glideslope deviations for the four energy management configurations 38

22. The RMS course deviations for the four energy management configurations 38

LIST OF TABLES

<u>Table No.</u>	<u>Page</u>
1. Accuracy, Initial Reaction Time, and Total Recovery Time for the Three CDL Line Configurations Collapsed Across Ghost Condition	27
2. Accuracy, Initial Reaction Time, and Total Recovery Time, With and Without the Ghost Horizon Collapsed Across the CDL Line Configuration	28
3. Mean Subjective Ratings for the Five VVI Configurations	34

Acquisition For	
NTIS CRA&I	M
DTIC TAB	[]
Unannounced	[]
Justification	
By	
Distribution	
Availability Codes	
Dist	Avail. and/or Special
A-1	

ACKNOWLEDGMENTS

This technical report represents the efforts of many people. Some never published a report, but they were nonetheless important to the project. We have tried to acknowledge the contributions of all those who kept sight of the need for attitude awareness on the head-up display (HUD).

The U.S. Government agencies primarily responsible for the HUD program are as follows: The USAF Aeronautical Systems Center/Joint Cockpit Office, the USAF Human Systems Center/Armstrong Laboratory, the USAF Aeronautical Systems Center/Wright Laboratory and Crew Station Evaluation Facility, the USAF Instrument Flight Center, the Tri-Service Flight Symbology Working Group (composed of members from the USA, USN, USAF, NASA, and several contractors), the USAF Flight Test Center, and the USAF Inspection and Safety Center (now called the AF Safety Agency).

In addition to acknowledging the support of these organizations, we would like to take this opportunity to thank specific individuals within these organizations who made the HUD standard a reality:

Joint Cockpit Office

Mr. Terry Emerson
Col. Jay Stretch

Armstrong Laboratory

Col. Don Spoon
Dr. Robert Osgood
Dr. Fred Previc
Ms. Fran Greene

Wright Laboratory

Dr. John Reising
Sq. Ldr. Robert Munns
Mr. Tony Ayala
Mr. William Augustine

Crew Station Evaluation Facility

Mr. John Hassoun
Mr. Tom Hughes
Mr. Chris Buell

USAF Instrument Flight Center

Col. John Buckner
Lt. Col. Richard Evans
Lt. Col. Gary Griffith
Lt. Col. Foster Bitton
Lt. Col. Edward Saflarski
Maj. Raymond Graves

USA/NASA

Mr. Loran Haworth

USN

Capt. (Ret.) "Hawkeye" Hughes
Mr. Curt Sandler
Mr. Gary Kessler
Mr. Richard Huff
Lt. Jennifer McGovern
Mr. Dan Eksusian

Contractors

Mr. Richard Newman
Mr. Pete Lovering
Mr. Randall Bailey
Mr. Manuel Tapia

The USAF Flight Test Center

Lt. Col. "Scoop" Cooper
Maj. Ron Johnston
Maj. Scott Horowitz
Maj. Michael Hoobler
Capt. Paul Hattendorf

The USAF Inspection and Safety Center

Col. (Ret.) Grant McNaughton

Many of the symbols and concepts used in developing the standardized HUD were adopted from existing symbology sets throughout the world. British researchers contributed many ideas; so did the Swedish, French, and New Zealanders. All these ideas were important in determining the ultimate configuration of the standard symbol set.

The work was conducted at the USAF Human Systems Center/ Armstrong Laboratory/Crew Systems Directorate/Crew Technology Division/Flight Motion Effects Branch. The authors would like to extend special thanks to the following individuals for their support of these studies:

Joe Fischer, Dan Bauer and Carolyn Oakley (statistical analyses), Christy Fischer (manuscript preparation), Beverly Johnson (graphics programming support), and SSgt. Stan Singleton (electronic support). This research was partially supported by a National Research Council Postdoctoral Fellowship to Dr. Weinstein, and partially funded by a U.S. Government contract to KRUG Life Sciences, San Antonio (contract # F33615-92-C-0018).

LIST OF ABBREVIATIONS

AOA -- angle of attack
AFFTC -- Air Force Flight Test Center
ANOVA -- analysis of variance
CDA -- climb/dive angle
CDI -- course deviation indicator
CDL -- climb/dive ladder
CDM -- climb/dive marker
CSEF -- Crew Station Evaluation Facility
DME -- distance measuring equipment
EU -- electronic unit
FDI -- Flight Dynamics, Incorporated
FOV -- field of view
FPM -- flight path marker
GSI -- glideslope indicator
HSI -- horizontal situation indicator
HDD -- head-down display
HUD -- head-up display
IFC -- Instrument Flight Center
ILS -- instrument landing system
JCO -- Joint Cockpit Office
PDU -- pilot's display unit
RAE -- Royal Aerospace Establishment
RMS -- Root mean square
RMSE -- Root-mean-squared error
USA -- United States Army
USAF -- United States Air Force
USN -- United States Navy
VHF -- very high frequency
VOL -- Visual Orientation Laboratory
VVI -- vertical velocity indicator
WRT -- with respect to

STANDARDIZATION OF AIRCRAFT CONTROL AND PERFORMANCE SYMBOLGY ON THE USAF HEAD-UP DISPLAY

CHAPTER I

HEAD-UP DISPLAY

Background

The idea of presenting head-up information dates back to the beginning of powered flight. When the Wright brothers needed flight information, they attached an 8-inch-long piece of string to the center wing spar directly in front of the pilot's face. The attached end of string, superimposed on the horizon, resulted in a display of aircraft performance (e.g., climb or dive). Unknown to the Wrights, the HUD was born. In fact, one of the most advanced fighter aircraft of today (F-15) still has a string attached to the aircraft canopy, providing important, easy-to-access flight information directly in front of the pilot's visual field.

When strings were not practical, resourceful pilots developed other tools. The windscreen of an airplane is one such tool, and a careful examination of a windscreen can explain how the term "bug smasher" became synonymous with the word "aircraft." Bug smears on the windscreen of early, open-air cockpit airplanes provided an excellent head-up tool for many instructor pilots. If the windscreen was clean or the bug smear was not handy, then a grease pencil was used to create an aiming reference. The technique is still used today throughout flight schools as both a visual reference for basic turns and as an aimpoint control for the final landing approach.

The basic concept behind the HUD is to display flight information in the area in front of the pilot's face, so the pilot does not have to look "down and in" the cockpit. Even though the technology of yesterday limited the capability of displaying anything more than a piece of string or a smudge on the windscreen, the concept of generating flight information between the windscreen and the pilot's eyes continued through years of aircraft development. Figure 1 depicts a 1955 concept of the future fighter cockpit that includes a HUD. The goal for researchers was to develop a HUD that contained all the basic flight information (an all-aspect HUD), and eventually could become the primary flight display--replacing the head-down instrumentation.

Special attention was given to the HUD in the armed forces, particularly for use in fighter aircraft. Fighter aircraft requirements have always been to "aim" and to "see and avoid." The pilot could not afford to visually fixate on instruments in the cockpit--for fear of losing sight, and losing fight. All the early fighter aircraft used a type of HUD for weapons aiming (some a little more sophisticated than others--but they all had one). The British Royal Air Force appears to be the first to use the HUD for more than a tool to aim a weapon. However, it was not until the Vietnam era that the need and the technology came together to produce a device similar to current HUDs.

The first all-aspect HUD in the U.S. Navy (USN) and U.S. Air Force (USAF) appeared during the 1960s with the A-7 aircraft. Pilots liked the concept, and many preferred the HUD in place of traditional head-down displays (HDDs). The Navy reported a reduction of aircraft carrier landing accidents due directly to the use of the HUD (Newman, 1980). Although procedures and techniques for its use were lacking, this new device was here to stay.

The early instrumented HUD seemed to be an answer to many problems. Most flight information could be displayed on a small glass directly in front of the pilot. More important, in the case of the military fighter cockpit where available head-down instrument panel space was very limited, the HUD freed additional space for more mission-essential displays (e.g., advanced sensor information). HUDs now transformed the "modern" military fighter cockpit into a more functional workstation. Nevertheless, caution was expressed by the early HUD developers.



Figure 1. 1955 concept of the future fighter cockpit.

"I will conclude by saying that the most important facet of the HUD is the fact that it is a device which must be used in conjunction with the real world in order to realize its potential. It should not be considered simply as a big panel which has suddenly become available to display all sorts of data. If you do this, you will not only fail to use the HUD as it should be used, but you are going to occlude some of the real world and cause a great deal of confusion." (Gold, 1968)

The occlusion concern noted by Gold seemed to be forgotten, and by 1985 the all-aspect HUD was an accepted instrument in most fighter cockpits. Military standards did not contain well-defined guidelines for the development of the HUD and Government contractors were able to design and develop their own "personalized" HUD. The central clearing house for all instrument flight displays, the USAF Instrument Flight Center, being closed for a period of 5 years, was not able to develop a standardization or certification process. A few military aircraft developers claimed the HUD provided the necessary information to accomplish "all" mission requirements, which included "all" flight conditions. However, after the investigation of several accidents, the HUD symbology was suspected as a contributing factor.

As a result of these accident investigation findings, the USAF safety community called for a conference on attitude awareness. The conference brought both operational pilots and researchers together for the first time to discuss problems associated with the HUD and attitude awareness. It became apparent during the conference that HUDs were (and would continue to be) used by pilots for attitude awareness, landings, and most other flight requirements. Several days of presentations and discussions led to critical recommendations. One of the major recommendations called for standardized HUDs. Standardization would reduce training costs, reduce development costs, improve functional utility, and provide a baseline for improvements as mission requirements changed. It would also insure that all pilots had the best displays possible. The conference concluded with the knowledge that a coordinated effort was needed. It was now the job of the research community to improve the state of HUDs for military use (McNaughton, 1985).

An underlying principle driving the standardization effort was the use of existing symbology and mechanization, at least as much as practical. This operational guidance, although seemingly restrictive, did help to focus the work, reduce the cost, and produce a product in a reasonable time period. Although new concepts could be tried, the new concepts had to be approved by military pilots who were already flying with HUDs. The end result was the development of a standardized HUD for use in unusual attitude recognition, all phases of instrument flight, and as many mission essential tasks as possible. A newly formed USAF Joint Cockpit Office (JCO) was assigned the responsibility of coordinating the effort.

Technology

The HUD is composed of three basic parts--the pilot's control unit, the pilot's display unit (PDU), and the electronic unit (EU). The control unit provides the pilot with the ability to adjust and select symbology, while the PDU contains the combiner glass and optics to project the symbology. The EU is the heart of the HUD and houses the software that not only generates the symbology, but also receives input from the aircraft sensors/platforms (Figure 2). Algorithms for symbology and mechanization reside within the EU.

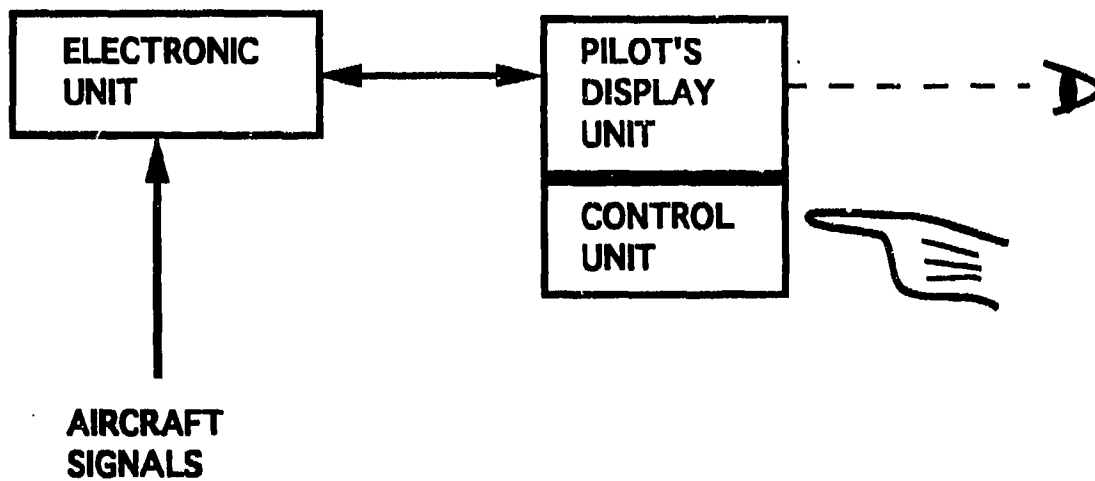

Figure 2. Schematic of the HUD.

A simple description of HUD functioning begins with the EU. The EU receives information (signals) from the navigation and spatial orientation systems of the aircraft. These signals are then processed and symbology is read by the computer from the aircraft programming code and written to the PDU. The symbology is projected through the lens system, focused at infinity, and reflected off the combiner glass (PDU). Some of the newer HUD techniques use an imbedded substrate "sandwiched" in the glass to produce more enriched symbology. A HUD that employs this technique is called a holographic HUD because of the optical interference pattern imbedded within the substrate. A holographic HUD *does not* mean that the pilot sees a 3-D representation of aircraft symbology.

Provided the eyes of the pilot are kept spatially located within a small cubical area (the design eye reference box), necessarily limited by the size of the lenses and technology used to focus the symbology, it will be possible to see sufficient flight symbology in the instantaneous field of view to fly and control the aircraft. Theoretically, the pilot should be able to interpret the state of the aircraft via the HUD symbology while integrating the symbology (focused at infinity) with real world scenery. If the HUD does not provide sufficient information, then additional displays must be provided for the maintenance of spatial orientation. The research goal is to maximize the information conveyed to the pilot, while minimizing the occlusion of the outside world due to the symbology.

The following chapters explain the studies conducted and results obtained over the past several years to design an optimal HUD. The final symbology and mechanization was the product of numerous independent studies, two full-scale simulations, and two inflight validations. The studies explained in this report were conducted primarily by scientists using the Visual Orientation Laboratory (VOL) in the Flight Motion Effects Branch of the Armstrong Laboratory (AL/CFTF). Chapter II more closely examines the research issues, Chapter III describes test methodology,

Chapter IV lists the results and findings, and Chapter V concludes with the discussion of flight simulation and validation. Appendix A contains a "coloring book" that lists each symbol and associated mechanization, and Appendix B explains the theory and application of quickening the HUD symbology.

CHAPTER II

RESEARCH ISSUES

The Joint Cockpit Office (JCO) in cooperation with the USAF Instrument Flight Center (IFC) was responsible for compiling the research findings and recommending the optimal configuration for a standard symbology set for use with the HUD as a primary flight reference. To be considered as a primary flight reference the HUD must provide: 1) full-time attitude, altitude, and airspeed information, 2) immediately discernable attitude recognition capability, 3) unusual attitude recovery capability, and 4) complete fault indications. Figure 3 shows a typical composite standard HUD configuration*. A complete description of the configuration can be found in USAF IFC TR 91-01 (Report on Head-Up Display Symbology Standardization) and ASC-TR-93-5003 (A Comparison of Head-up and Head-down Display Formats During Instrument Flying Tasks). In addition to standardizing symbology, the USAF also attempted to standardize terminology, mechanization and arrangement for use in all phases of flight except for those mission segments requiring specialized design.

This chapter reviews the research studies conducted and existing literature reviewed in the development of the individual elements of the USAF HUD symbology standard. The research issues center on the presentation of visual flight information to the pilot. The flight information can be divided into the basic concepts of piloted aircraft flight: control, performance, and navigation. Aircraft performance is achieved by controlling the aircraft attitude (the relationship of the longitudinal and lateral aircraft axes to the Earth's surface) and power. An aircraft is flown in instrument flight by controlling the attitude and power as necessary to produce the desired performance. The same procedure is used for visual flight, except that the actual horizon is used in place of an artificial horizon (located on the attitude indicator.) This concept is known as the "control and performance concept" of attitude instrument flying (Rastellini, 1986).

Control Instruments

These instruments display immediate attitude and power indications and are usually calibrated to permit adjustments in discrete amounts. Control is determined by reference to the attitude indicators and power indicators. On occasion, when the rudders are used to control attitude, the slip (turn and bank) indicator is considered a control instrument. The command steering bars (or tadpole) are not calibrated in discrete amounts, yet the command information displayed (pitch and bank) is usually considered a control indication.

Climb/dive Ladder

One control standardization issue, which was examined by a number of investigators, is the configuration of the climb/dive ladder (CDL). The CDL displays climb/dive and bank of the aircraft with respect to the climb/dive marker. A tri-service simulation study conducted at NASA Ames Research Center examined various CDL formats, various compression algorithms for the CDL lines, and the use of a quickened flight path marker. (A thorough description of the theory

* The HUD displays most control, performance, and navigation data simultaneously in a relatively small area. USAF HUD equipment currently in use is not certified for sole-reference instrument flight. Therefore, HUD data must be verified with other cockpit instruments.

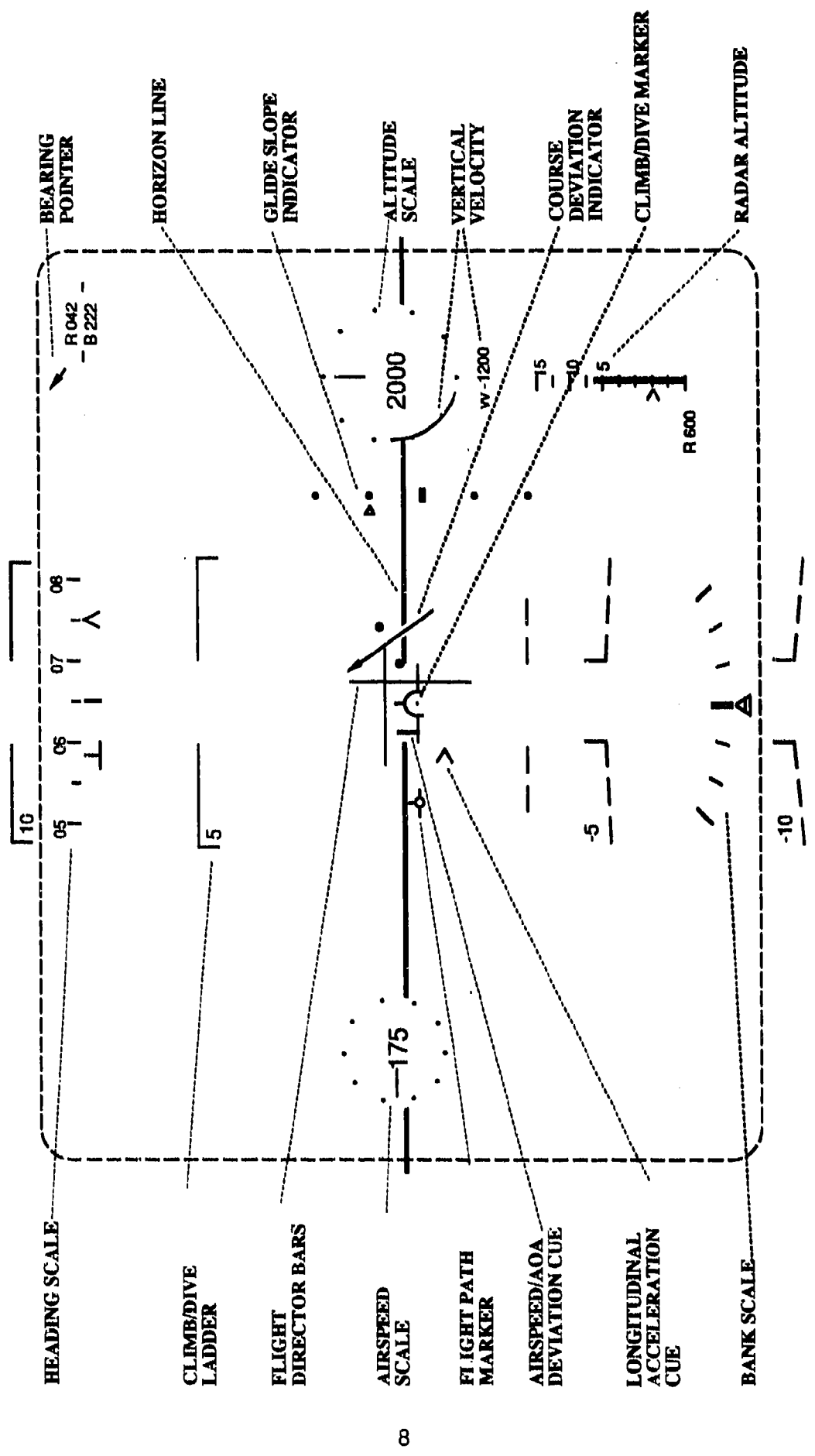

Figure 3. A typical composite standard HUD configuration.

and application of quickening to the USAF standard HUD can be found in Appendix B.) The subjective ratings from the pilots in that study indicate that vertical asymmetry (between the top and bottom halves of the CDL) and quickening reduce subjective workload and are preferred. Trends observed in the objective data tend to support these preferences, although there were no significant performance differences.

One type of vertical asymmetry of the CDL that has been discussed is the use of articulated lines to indicate negative pitch angles and tapered, parallel lines to indicate positive pitch angles. Articulation refers to the angling of the lines at half the number of degrees they represent (e.g., the 5 degree line is slanted at 2.5 degrees). A study by Zenyuh, Reising, McClain, Barbato, and Hartsock (1987) found articulated lines beneficial in aiding unusual attitude recovery. Ward and Hassoun (1990) conducted a simulation study that compared the F-16 CDL (no articulation), a fully articulated ladder, and a ladder with articulation in only the bottom half of the HUD. The results of this experiment indicated that articulation in the bottom half of the ladder aided in an unusual attitude recovery task. In spite of these results, there has been some concern whether articulated lines give a pilot adequate roll information to allow bank attitude identification, information necessary to recover from dangerous nose-down unusual attitudes. British researchers, in a simulation study, noticed that when the bottom half of the CDL was articulated, there was a tendency to roll in the incorrect direction and pull the nose of the aircraft down, worsening an already dangerous nose-low situation (John Hall, personal communication).

The configuration of the CDL was one item that caused confusion. After learning of the British concern, the IFC was reluctant to make a recommendation regarding the articulated lines in the bottom half of the HUD. Therefore, the IFC decided to attempt to reconstruct the problems noted by the British in a laboratory simulation designed to examine the problems associated with articulated lines in the bottom half of the HUD in nose-down pitch attitudes. The study explored a pilot's ability to recover from nose-down unusual attitudes with articulated lines versus parallel, tapered lines on the bottom of the CDL (Weinstein and Ercoline, 1991). The study also examined the effects of the initial location of the flight path marker (FPM) by examining recovery performance with both a pitch reference and an FPM. An FPM represents the true velocity vector of the aircraft and is free to move about the HUD while a pitch reference remains fixed on the display. The results showed that nose-down unusual attitude recovery performance was significantly less accurate (by about 10%) with the articulated lines on the bottom half of the CDL and an FPM than with the other three configurations.

The decrease in accuracy was manifest in several instances in the same manner noted by the British researchers. However, the use of the pitch reference eliminated the problem: there was no difference between the condition with the articulated lines on the bottom half of the ladder with the pitch reference and those with the parallel, tapered lines on the bottom half of the ladder. The user community had a strong preference for the articulated lines in the bottom half of the HUD, so the JCO decided to adopt a ladder with tapered lines in the top half and articulated lines in the bottom half. The configuration was later evaluated in a full-scale simulation effort and no problems were noted. Although this configuration has been adopted for use with the proposed USAF standard, research continues to determine the optimal configuration of vertical asymmetry on the CDL.

Several additional studies were conducted that examined various attributes of CDLs. A Navy study examined variations in CDL configurations (Deaton, Barnes, Lindsey, Greene, and Kern, 1989). One objective of the study was to evaluate unusual attitude recovery performance using a standard CDL configuration (straight lines top and bottom) compared to an enhanced CDL that included "saw-teeth" on articulated lines in steep negative pitch attitudes. The results indicated

that the enhanced CDL significantly reduced unusual attitude recovery time, but only for steep dive situations. This finding was expected given that the most salient difference between the configurations is only visible in steep dive situations. A preference survey of the subjects revealed that pilot opinion correlated with performance.

In an additional study of HUD configurations, Ercoline, Gillingham, Greene, and Previc (1989) examined modifications to the HUD CDL in a static attitude recognition study. Their results indicated that straight lines resulted in more accurate bank recognition than did articulated lines, while articulation in the top and bottom halves of the HUD resulted in the most accurate pitch recognition. The study also confirmed the findings of the United States Navy study showing that a gradually increasing thickness for the nose-down portion of the CDL increases the subject's ability to recognize negative pitch attitudes. An interesting observation in the Ercoline et al. study was that pitch angle numbers placed only on one side of the CDL aided bank recognition. This modification is now used in most HUD studies and has been accepted as a standard design feature, provided the CDL is used in the drift cut-out (caged) mode. In an uncaged mode, the ladder is free to drift laterally and the numbers would need to be on both sides of the ladder to be visible all the time.

Horizon Line

A second control standardization issue involved the configuration and mechanization of the CDL horizon line. The horizon line represents the actual horizon and is part of the CDL. Several studies have been conducted that confirmed the utility of a full field-of-view horizon line that will "ghost" when it is outside the HUD instantaneous field-of-view (Dryden, 1990; Weinstein, Ercoline, and Bitton, 1992). The ghost horizon is designed to indicate the direction of the actual horizon when the CDL horizon line is not visible through the HUD glass. In an earlier study, pilots reported that the ghost horizon line was an excellent aid to recovering from unusual attitudes (Reising, Zenyuh, and Barthelemy, 1988). The USAF has adopted the use of the ghost horizon on the standard HUD.

Sky Pointers

The user community had suggested including sky pointers on the ghost horizon and the actual horizon line to provide a salient indication of the direction of the sky. Scientists at the Armstrong Laboratory, Brooks AFB, examined the use of sky pointers on the ghost horizon (see Chapter 4 for details of the study). Subjective comments indicated that the pointers were not noticed by some pilots, and others found the pointers confusing. The ticks on the end of the CDL lines are horizon pointers, so it was possible to have the sky pointers on the ghost horizon and the horizon pointers on the CDL lines opposing each other. As a result of these comments, the sky pointers were not included on the ghost horizon.

FPM/CDM

A third control standardization issue was one of designating HUD symbols for the FPM and climb/dive marker (CDM). The FPM represents the total velocity vector of the aircraft, while the CDM shows the climb/dive angle of the aircraft with respect to the CDL. The FPM has traditionally been a circle with wings and a tail (-6-) used as a control reference for the aircraft. However, since the CDM will now be primarily used to control the aircraft, while the FPM will be free to display the total velocity of the aircraft, the question that had to be answered was: which of these symbols should look like a traditional FPM--the symbol that moves like a traditional FPM, or the symbol used to control the aircraft? This issue was explored by investigators at the Wright

Laboratory at Wright-Patterson AFB. They concluded that the FPM should still look like an airplane symbol only be smaller, and the CDM should be a symbol easily recognized as a control symbol and should be larger than the FPM. Figure 4 illustrates the symbols that will be included in the standard HUD symbology set.

Bank Indicator

The bank indicator adopted was the current F-16 C/D symbology and mechanization. No studies seemed necessary for this decision.



Figure 4. The CDM and FPM symbols used in the standard HUD symbology set.

Performance Instruments

These instruments indicate the actual performance of the aircraft. Performance is determined by reference to the altimeter, airspeed or mach indicator, vertical velocity indicator, heading indicator, angle-of-attack indicator, and turn and slip indicator. Depending on the type of aircraft, performance indicators often lag the control inputs.

Airspeed and Altitude Indicators

One of the performance standardization issues involved the presentation format of the airspeed and altitude indicators. Ercoline and Gillingham (1990) conducted a study that examined five different altitude and airspeed indicator formats. The experiment required subjects to maintain straight and level flight while a forcing function generated by a sum of sinusoids caused deviations in the displayed altitude and airspeed. The results of the study revealed that pilots' performance errors were lower with two new formats--rotating pointers with dot scales and plain rotating pointers--than with two more common formats--boxed digits and moving vertical tapes. Digits representing altitude and airspeed conjoined with rotating pointers are now frequently referred to as counter-pointers. A fifth variation, boxed digits with trend bars, provided the best performance with respect to altitude error, but not airspeed error.

Subjective opinions were also significantly different and correlated with performance measures. Chapter 4 contains a more detailed explanation of the Ercoline and Gillingham study including illustrations of the displays evaluated. A study by Hughes and Lovering (1990) also found that a counter-pointer presentation for airspeed and altitude information was superior to vertical tapes.

Vertical Velocity Indicator

A second performance standardization issue, investigated by the Armstrong Laboratory at Brooks AFB, was the utility of presenting vertical velocity information. The study was designed to determine if analog vertical velocity information was superior to a digital readout, and if so,

what format the analog information should take. Pilots were asked to perform precision instrument control tasks with various analog and digital formats. Five configurations were assessed: digital readout, boxed digit with tape, dial, altimeter arc, and altimeter arc with digital readout. Illustrations of the vertical velocity indicators and the results can be found in Chapter 4. The results clearly indicated that the altimeter arc with digital readout, and the altimeter arc alone, resulted in significantly more accurate maintenance of flight parameters (i.e., vertical velocity and altitude) than did the digital readout alone or the dial or tape configurations (Weinstein, Ercoline, Evans, and Bitton, 1992). Subjective data supported the objective findings, in that pilots preferred either configuration that included the altimeter arc. These findings suggest that analog vertical velocity information is useful on the HUD particularly when it is located in close proximity to the altimeter.

Angle-of-attack Indicator

Two other performance standardization issues were investigated at the Armstrong Laboratory: 1) the optimal presentation format of speed/angle-of-attack deviation, and 2) the utility of and optimal presentation format for longitudinal acceleration/potential flight path. Angle-of-attack and longitudinal acceleration cues display information to the pilot about the energy state of the aircraft, and are therefore referred to as energy management cues. The results of a study that examined both of these energy management cues during an Instrument Landing System (ILS) approach indicated that the angle-of-attack and acceleration information are useful cues on the HUD. Four configurations were assessed: a configuration similar to that marketed by Flight Dynamics, Inc. (FDI), a configuration similar to that in the Mirage 2000, an angle-of attack "E" bracket, and an angle-of attack "E" bracket with an acceleration caret. Approaches flown with the FDI configuration had significantly smaller airspeed, angle-of-attack, and glide slope errors than did approaches flown with the other three configurations. The FDI configuration has been recommended for inclusion on the standard HUD. Illustrations of the energy management cue configurations evaluated and the detailed results of the study can be found in Chapter 4.

Navigation Instruments

These instruments indicate the position of the aircraft in relation to a selected navigation facility or fix. This group of instruments includes various types of course indicators, range indicators, glideslope indicators, and the bearing pointer.

Instrument Landing System Symbology (raw)

Along with displaying traditional attitude information, the HUD must also present information to support navigation and landing tasks. Therefore, a navigation standardization issue explored by several investigators involves the optimal design of the symbols that support these tasks. At the Crew Station Evaluation Facility (CSEF) at Wright-Patterson AFB, Burns (1990) examined three ILS symbology formats, to evaluate a moving versus a fixed reference point, and separate versus integral pitch and bank cues. The results indicated that a fixed reference point and separate pitch and bank cues resulted in the best performance. This configuration presents an interesting problem, since all HUDs use a dynamic flight path marker or climb/dive marker for the aircraft control reference. Further research may indicate that quickening may solve the problem by reducing the motion of the flight path marker (see Appendix B).

Instrument Landing System Symbology (command)

A simulation study conducted at CSEF examined various flight director symbology sets during approach and landing, navigation, and unusual attitude recovery tasks (Hughes and Lovering, 1990). HUD-experienced pilots performed the above tasks in an F-16 simulator and their performance was measured. The results of that study indicated that a dual-cue (separate) flight director system resulted in better performance than did a single-cue (integral) system.

CHAPTER III

GENERAL TEST METHODS

Subjects

For each of the studies HUD-experienced, and non-HUD-experienced, military pilots volunteered to participate. The pilots had experience in a number of HUD-equipped aircraft, including the A-10, F-14, F-15, F-16, F-18, F-117, Jaguar, Tornado, and Harrier. The non-HUD-experienced pilots had flown B-52, C-9, C-130, C-141, F-111, T-27, and T-38 aircraft. A majority of the subjects were recruited from the Instrument Flight Center and the 12th Flying Training Wing, Randolph Air Force Base, Texas.

Apparatus

Each experiment was conducted in the VOL in the Crew Technology Division, Crew Systems Directorate of the USAF Armstrong Laboratory at Brooks AFB, Texas. The VOL includes (a) a Silicon Graphics IRIS 3130 computer workstation, (b) a Sony VPH-1030Q1 color video projector, (c) a subject booth containing a Draper Cine-15 viewing screen, and (d) a simulated F-16 aircraft seat with a side-arm force-stick controller on the right and a throttle on the left. The height of the video projector and the viewing screen is adjustable; thus, the center of the projected image can be set at eye level for a subject sitting in the simulated aircraft seat.

Tasks

Three general types of tasks were used during the evaluations of the symbology: unusual attitude recovery, precision instrument control, and ILS approaches. These tasks were used in the VOL simulations, the Crew Station Evaluation Facility full-scale simulation effort, and the inflight validation.

Unusual Attitude Recovery Task

The recovery task involved returning a computer-generated image of a HUD to a wings level, upright flight position as quickly as possible, and in accordance with AFM 51-37, Instrument Flying, procedures. Between 8 and 20 attitudes were selected for each evaluation, and several repetitions of each attitude were completed. The number of attitudes selected and the number of repetitions completed varied, depending on the number of HUD configurations to be evaluated in each study. The desired outcome was to maintain a reasonable number of trials for the subjects to complete without fatigue or boredom becoming a significant factor. A balanced number of upright and inverted attitudes, as well as left and right banks were included in each evaluation. Nose-up and nose-down recoveries were completed by the subjects, although the data from the nose-up trials were not analyzed because USAF instrument procedures do not specify one definitive, correct recovery procedure from a nose-up attitude. In nose-low unusual attitude conditions, the pilot is instructed to roll the aircraft to less than 90 degrees of bank before adding back pressure to the stick (Rastellini, 1986).

The subjects were asked to perform the unusual attitude recoveries with each of the HUD configurations. The HUDs were presented with a gray background scene simulating flight in instrument meteorological conditions. Subjects were allowed to "free-fly" each HUD until they

were comfortable with its operation, and were then allowed to practice recoveries until they indicated that they were ready to start the experimental trials. The "free-flight" and practice trials for each HUD were flown immediately before the set of experimental trials for that display. The HUD presentation order was balanced and the trial order was randomized across subjects. The dependent variables were accuracy of initial stick input (i.e., did the subject initially roll in the correct direction), the reaction time to the initial stick input, and the total time to completion of the recovery.

Subjects were also asked to complete a preference questionnaire at the end of each study. The questionnaire was modified for each evaluation to elicit the pilots' opinions regarding the particular symbols examined. In general, subjects were asked to respond to statements presented in a modified Likert Scale format similar to the following example.

"The tapered climb/dive ladder allowed me to maintain orientation."

1-----2-----3-----4-----5-----6-----7
strongly neutral strongly
disagree agree

Precision Instrument Control Task

Several of the symbology evaluations required the pilots to perform basic flight instrument maneuvers involving precise skill in manipulating various aircraft control and performance parameters (e.g., altitude, airspeed, bank, and vertical velocity). In the task used to evaluate the altitude and airspeed symbology, subjects had to maintain a target altitude and airspeed while a sum-of-sinusoids perturbation altered the altitude of the simulated aircraft. Airspeed changes were the result of the subject's stick and throttle adjustments for altitude control. The changing altitude condition repeatedly challenged the subjects to recognize altitude and airspeed deviations (crosscheck) and then to adjust the aircraft attitude and power to reestablish the target altitude and airspeed.

The tasks used to evaluate the vertical velocity indicators were vertical S instrument maneuvers. One task was the vertical S alpha which is a climb and descent flown on a constant heading. Subjects were asked to climb from 8500 ft to 9500 ft and then descend to 8500 ft with a constant vertical velocity of ± 1000 ft/min, an airspeed of 360 knots, and a heading of 010 degrees. Another task employed was the vertical S delta, which also involved a climb from 8500 ft to 9500 ft and a descent to 8500 ft, at a vertical velocity of ± 1000 ft/min and an airspeed of 360 knots. In the vertical S delta, however, a 30 degree right bank is added during the climb and the direction of the bank is reversed at the top to 30 degrees left for the descent. In this case, heading is irrelevant. Random vertical motion perturbations, generated by a sum-of-sinusoids forcing function, were used to increase the difficulty of the vertical S tasks. When they are performed correctly, the vertical S alpha and delta tasks should take 2 minutes each to complete.

The dependent variables varied according to the actual task performed. For example, during a vertical S task in which a subject is asked to maintain a set vertical velocity and bank angle, the deviations from the set vertical velocity and bank angle were recorded and analyzed. General performance data such as altitude, airspeed, and heading were also recorded.

Instrument Landing System Approach Task

One of the tasks used to evaluate symbology was a simulated ILS precision approach. The ILS, composed of a localizer and glideslope, is the most commonly used instrument approach aid for USAF pilots. The localizer is defined by a very high frequency (VHF) radio signal aligned with the centerline of the runway, providing lateral displacement information. Vertical guidance (glideslope) is a similar signal set at a predetermined elevation angle. The intersection of the two signals provides precise guidance in azimuth and elevation. Depending on the aircraft display, the signals are coupled by an airborne receiver and displayed as either one single purpose cue (tadpole) or two independent cues.

Usually, the aircraft is directed toward the final approach portion of the ILS at a minimum intercept altitude. Localizer centerline is captured at the minimum intercept altitude prior to glideslope capture (descent). The final approach starts at the glideslope intercept point and ends at a specified altitude (decision height) where the pilot must decide to either complete the landing or abort the landing and go around. Values of the glideslope angle, the minimum intercept altitude, and decision height are determined by the runway location and surrounding terrain. As the aircraft approaches the runway on the final approach, the signals become more sensitive and smooth, precise control inputs are required.

The dependent measures evaluated for the ILS task include deviations from a predetermined glideslope, localizer, altitude, airspeed, angle-of-attack, and acceleration. These parameters measure the pilot's ability to maintain the desired flight path as well as to optimize aircraft performance with efficient energy management.

Data Analysis

The Silicon Graphics workstation records the performance data for each trial and each subject in a separate data file. The time histories for each parameter were sampled and recorded at a rate of 10 Hz. At the conclusion of the experiment, the data are reduced by averaging the performance within a trial. For example, if airspeed deviations were measured every 500 milliseconds for a 4-minute flight trial, the average airspeed deviation for that trial was calculated and reported as a summary statistic for that trial. This process was conducted for each performance parameter, trial, and subject. The resulting database consisted of an average value for every parameter recorded on each trial conducted during the experiment. The database was then subjected to standard inferential statistical analysis procedures [e.g. analysis of variance (ANOVA), Duncan range test] using the commercially available SAS statistical package.

CHAPTER IV

ELEMENT DEVELOPMENT STUDIES

Altitude and Airspeed

Objective

This study was designed to determine which of five altitude and airspeed symbol sets would be most effective for use on the standardized HUD. A detailed description of the study can be found in Ercoline and Gillingham (1990).

Method

Subjects. Seven HUD-experienced and 18 non-HUD-experienced pilots volunteered to participate in the study. The average total flight time for the subjects was 2,800 hours.

Displays. Each HUD symbol set consisted of pitch-ladder lines [climb/dive angle (CDA) markers], a pitch index symbol (miniature aircraft), a ground pointer, a bank scale, a heading scale, and one of five different sets of airspeed and altitude readouts. A digital tachometer was located on the lower left side of the traditional instrument panel. The tachometer provided a visual reference to be used in establishing the beginning thrust requirement for target airspeed (approximately 90% rpm for 360 knots).

Figure 5 illustrates the five HUD altitude and airspeed symbol sets: 1) moving vertical tapes, 2) rotating pointers with dots, 3) plain boxed digits, 4) rotating pointers, and 5) trend bars. The altitude was displayed on the right-hand side of the HUD, slightly above the mid-position, and the airspeed was displayed in a corresponding position on the left. In the first format, vertical tapes (similar to those used in the F-16), consisted of moving altitude and airspeed scales that were indexed by stationary pointers on the medial sides of boxed digital displays. The second format consisted of pointers, analogous to those of a round dial altimeter or airspeed indicator, rotated about a digital display like hands on a clock. Ten dots were placed equidistant around the circles described by the distal ends of the moving pointers. Plain boxed digits (similar to the symbology used in the F/A-18) constituted the third format. The fourth format was the same as the second, except the dots were removed. The fifth format displayed the instantaneous rates of change of the altitude and airspeed as trend bars above or below boxed digital displays.

Task. Subjects were asked to fly a basic instrument profile, i.e., to maintain straight and level flight (2,000 feet and 360 knots), for 200 seconds. The sum of five sinusoids with different frequencies, amplitudes, and phases was used to perturb the altitude depicted on the altimeter display. Airspeed changes were the result of the subject's stick and throttle adjustments for altitude control. All test subjects received the same altitude perturbation. The changing altitude condition challenged the subjects repeatedly to recognize altitude and airspeed deviations (crosscheck) and then to adjust the aircraft attitude and power to reestablish target altitude and airspeed. Deviations of altitude and airspeed from target values (dependent measures) were calculated as root mean square (RMS) errors. The level of difficulty was similar to that of flight conditions requiring a

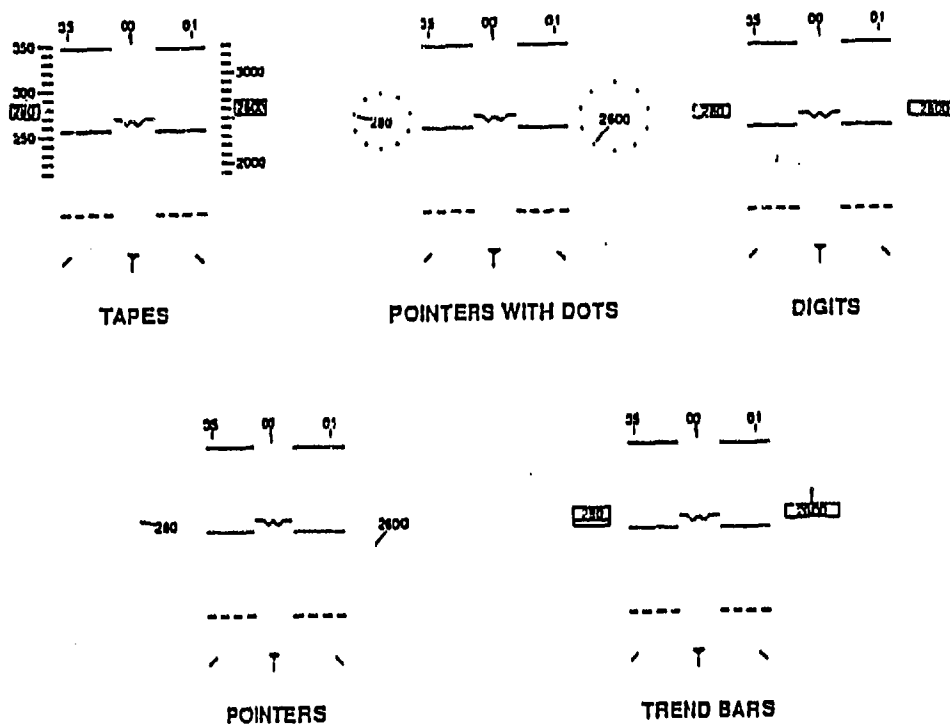

Figure 5. The five HUD altitude and airspeed symbol sets: 1) moving vertical tapes, 2) rotating pointers with dots, 3) plain boxed digits, 4) rotating pointer and 5) trend bars.

continuous, concentrated instrument crosscheck. Performance was first measured with 60 seconds of straight and wings-level flight without any altitude perturbation (turbulence). The subjects were then given the 200 seconds of perturbed (turbulent) flight.

The pilots' post-test subjective estimates of confidence in their ability to use the various displays were also collected. Subjects were asked to rate the five displays on a whole number scale from 1 to 5, with 1 representing the best and 5 representing the worst case.

Results

The altitude and airspeed performance RMS errors were subjected to a two-way ANOVA. The altitude and airspeed RMS errors are shown as a function of display type in Figures 6 and 7, respectively. For both altitude and airspeed measurements, the null hypothesis that the different displays were not associated with different performances was rejected ($p < 0.001$). Duncan's multiple range test revealed that, for altitude control, the trend bars and both rotating pointer formats were associated with performance scores significantly better ($p < 0.01$) than those associated with the tapes and plain boxed digits. For airspeed control, the two rotating pointer formats gave better performance scores ($p < 0.01$) than did the other three formats (Figure 7).

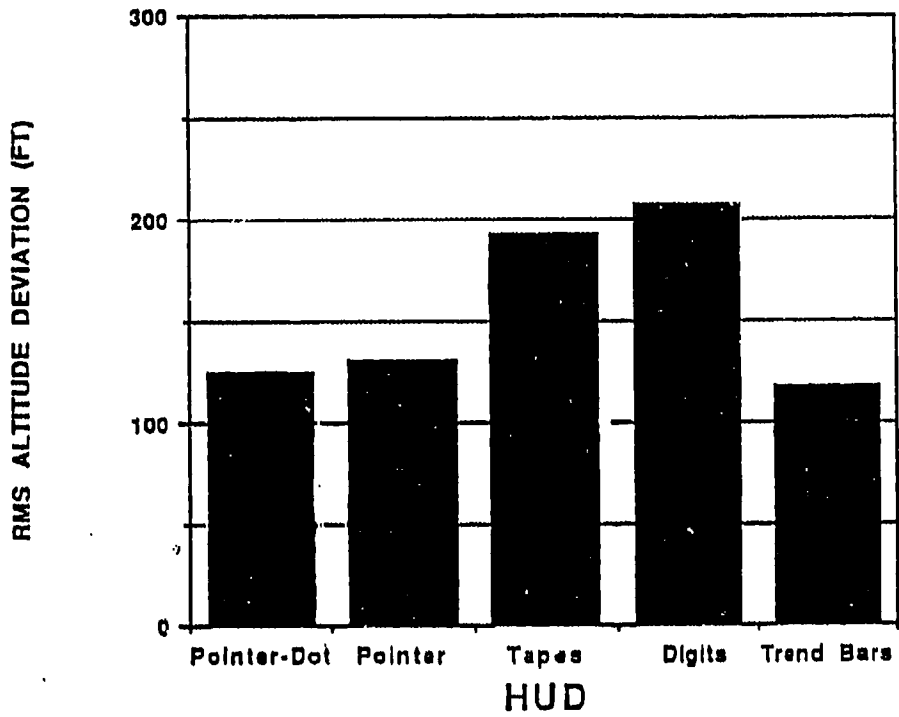

Figure 6. Mean altitude error (RMSE) with the 5 altitude and airspeed display formats.

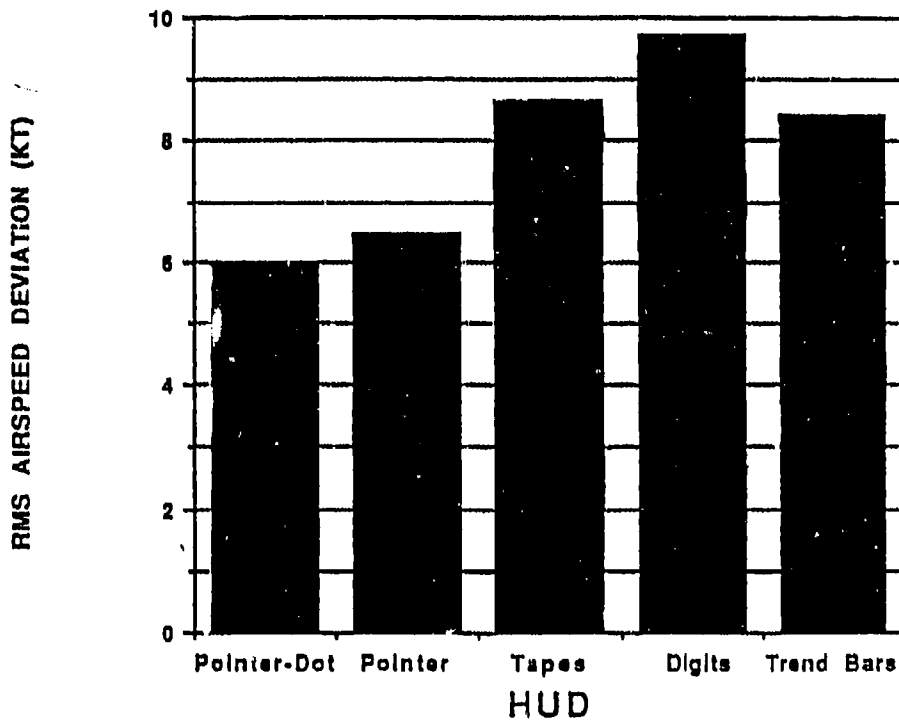

Figure 7. Mean airspeed error (RMSE) with the 5 altitude and airspeed display formats.

The results of the post-test subjective evaluations (Figure 8) were consistent with the objective findings. Friedman's two-way ANOVA revealed that the subjects' confidence in their ability to use a display for the required task (instrument crosscheck) significantly differed ($p < 0.0001$) among the displays. Duncan's multiple range test indicated that the rotating pointer formats and the trend bars were preferred significantly ($p < 0.001$) over the other two formats.

Summary

The results suggest that altitude and airspeed information presented in the rotating pointer HUD formats is easier for pilots to assimilate than is such information presented in the vertical tapes and boxed digits formats. Rotating pointers are probably more effective because their position and movement are relatively easy to detect in parafoveal and peripheral vision while foveal vision is occupied with reading the digital representations of altitude/airspeed and with monitoring other parameters (e.g., pitch/bank attitude).

Articulation/Pitch Reference

Objective

The objective of this study was to determine the effects of articulated lines versus parallel, tapered lines in the top and bottom halves of the climb/dive ladder (CDL). In addition, the CDL effect was examined with a moving climb/dive marker (CDM) and a fixed pitch reference to simulate the difference between an unquickened and quickened symbology mechanization, respectively. Appendix B explains the theory and application of quickening the HUD. A detailed description of the study can be found in Weinstein and Ercoline (1991).

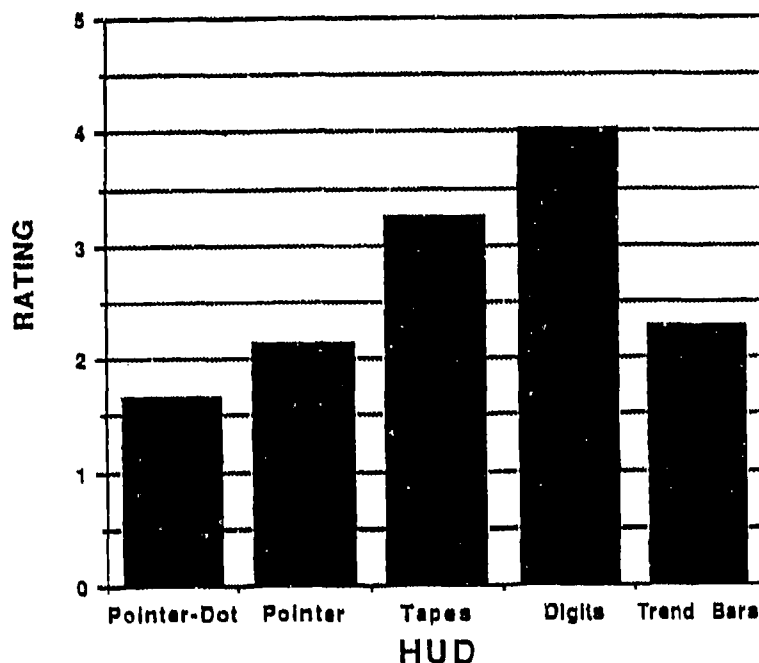

Figure 8. Mean subjective ratings for the 5 altitude and airspeed display formats. A rating of "1" was very favorable and "5" was very unfavorable.

Method

Subjects. Twelve HUD-experienced military pilots volunteered to participate in the study. The average total flight time for the subjects was 2,300 hours, including an average of 750 hours of HUD flying time. The pilots had experience in a number of HUD-equipped aircraft, including the A-10, F-15, F-16, Hawk, Jaguar, and Tornado.

Displays. Figure 9 illustrates the four displays in a 145-degree right bank and 40-degree nose-down pitch attitude. There were four HUD configurations evaluated in the experiment. Increasingly articulated lines were compared to parallel, tapered lines, with a moving CDM and a fixed pitch reference, resulting in the four HUD configurations shown in Figure 9: 1) parallel, tapered lines on the top; articulated lines on the bottom with a moving CDM; 2) parallel, tapered lines on the top; articulated lines on the bottom with a fixed pitch reference; 3) articulated lines on the top; parallel, tapered lines on the bottom with a moving CDM; and 4) articulated lines on the top; parallel, tapered lines on the bottom with a fixed pitch reference.

Task. The unusual attitude recovery task was employed in this study. The pitch and bank attitudes used in this study assured that the subjects viewed only the top or bottom half of the CDL (with no horizon line) when a trial commenced. The subjects were asked to perform 32 different unusual attitude recoveries with each of the 4 HUD configurations, resulting in a total of 128 trials per subject. All trials were run during a 1-hour session.

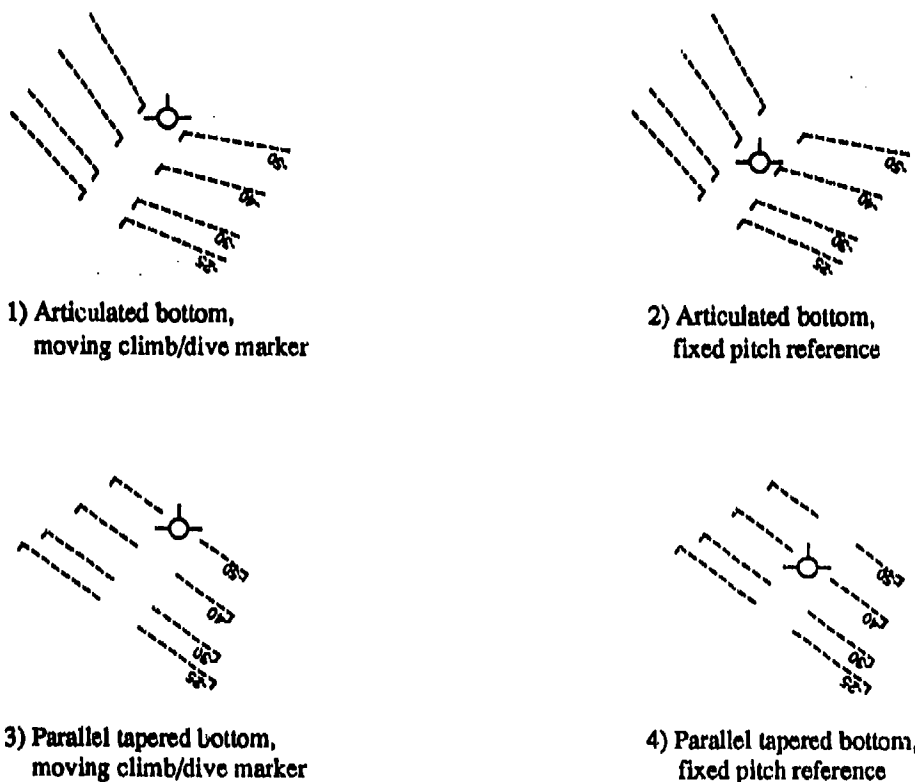

Figure 9. The four HUD configurations illustrating a 145-degree right bank and 40-degree nose-down pitch attitude.

Results

Objective data. The subjects' stick inputs were recorded, as well as the reaction time to the first significant stick input. The accuracy (correctness) of the initial, significant stick input was used in the analysis. A significant stick input was defined as an input in the x or y axis of more than 5% of the operating force (voltage) range. ANOVAs were conducted on these measures to assess the differences in recovery performance with the four displays. Figure 10 depicts the accuracy data. There was a significant effect due to HUD type ($F(3,11)= 5.01, p<.01$). The parallel, tapered top, articulated bottom with the moving CDM resulted in significantly less accurate performance (72% correct) than that associated with the other three HUDs. There was no significant difference in accuracy between the other three configurations: parallel, tapered top, articulated bottom, fixed pitch reference (83%); articulated top, parallel, tapered bottom, moving CDM (89%); articulated top, parallel, tapered bottom, fixed pitch reference (89%).

The errors in initial pitch and roll input were further evaluated to determine if the subjects in the current experiment made mistakes similar to those found by earlier researchers. In a nose-down orientation, the proper recovery procedure is to begin a roll towards a wings level, upright orientation; when the bank is less than 90 degrees, back pressure can be applied on the control stick to reduce pitch. The plots of the pitch and roll angle revealed that, in seven cases with the articulated lines on the bottom, subjects appeared unable to determine that they were inverted, and rolled in the wrong direction or applied back pressure before achieving a bank of less than 90 degrees--which either delayed their recovery or steepened their dive angle, thereby worsening the situation.

The reaction-time data are shown in Figure 11. The ANOVA on the reaction-time data revealed no significant differences between displays. Apparently, the subjects responded with quick initial stick inputs (average reaction time=.66 seconds) regardless of the HUD type.

Subjective data. At the completion of the session, each subject completed a preference questionnaire. The results of that survey revealed that five subjects had a strong preference for the articulated bottom, parallel, tapered top with a fixed pitch reference, while two additional subjects had a slight preference for that configuration. Four subjects preferred the articulated top, parallel, tapered bottom with a moving CDM. One subject had no preference.

Summary

The results indicated that the CDL configuration did not affect a pilot's reaction time to initiate a recovery. However, in terms of accuracy of the initial, significant stick input, the articulated lines in the bottom half of the HUD with a moving CDM resulted in significantly poorer performance (about 12% worse) than that associated with the other three configurations.

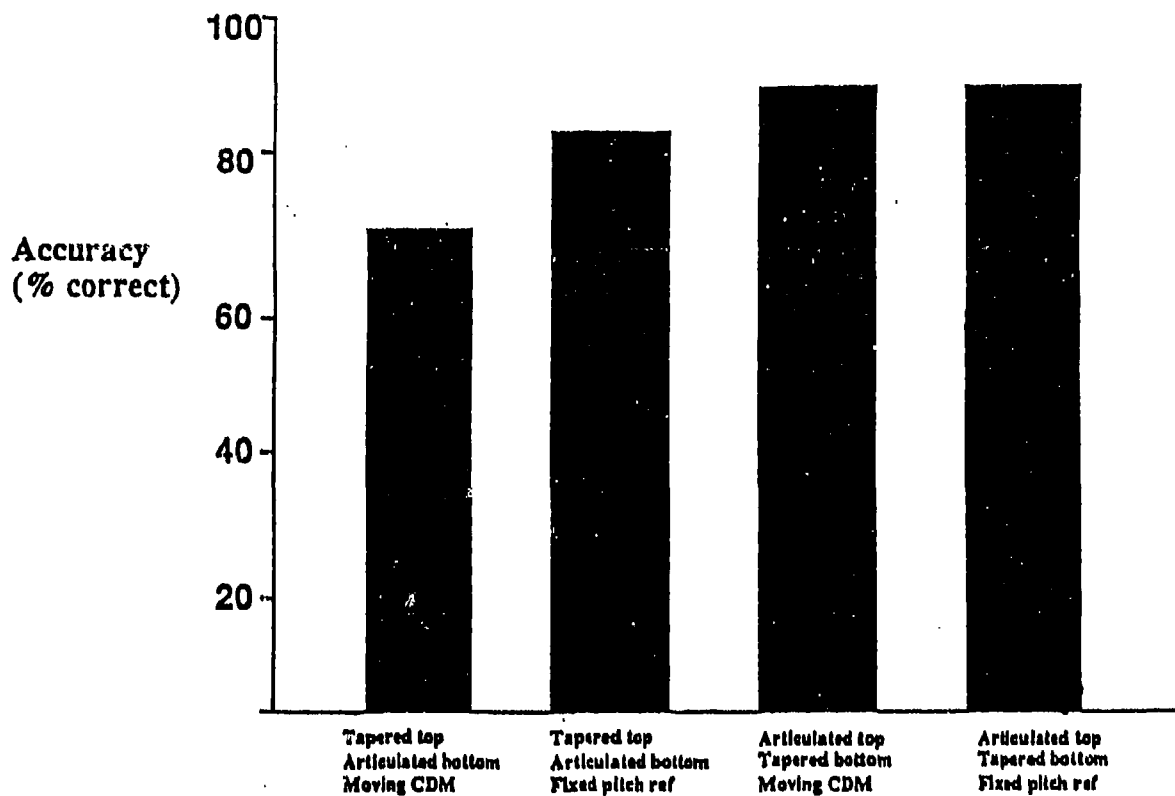

Figure 10. Accuracy data for the four articulation configurations.

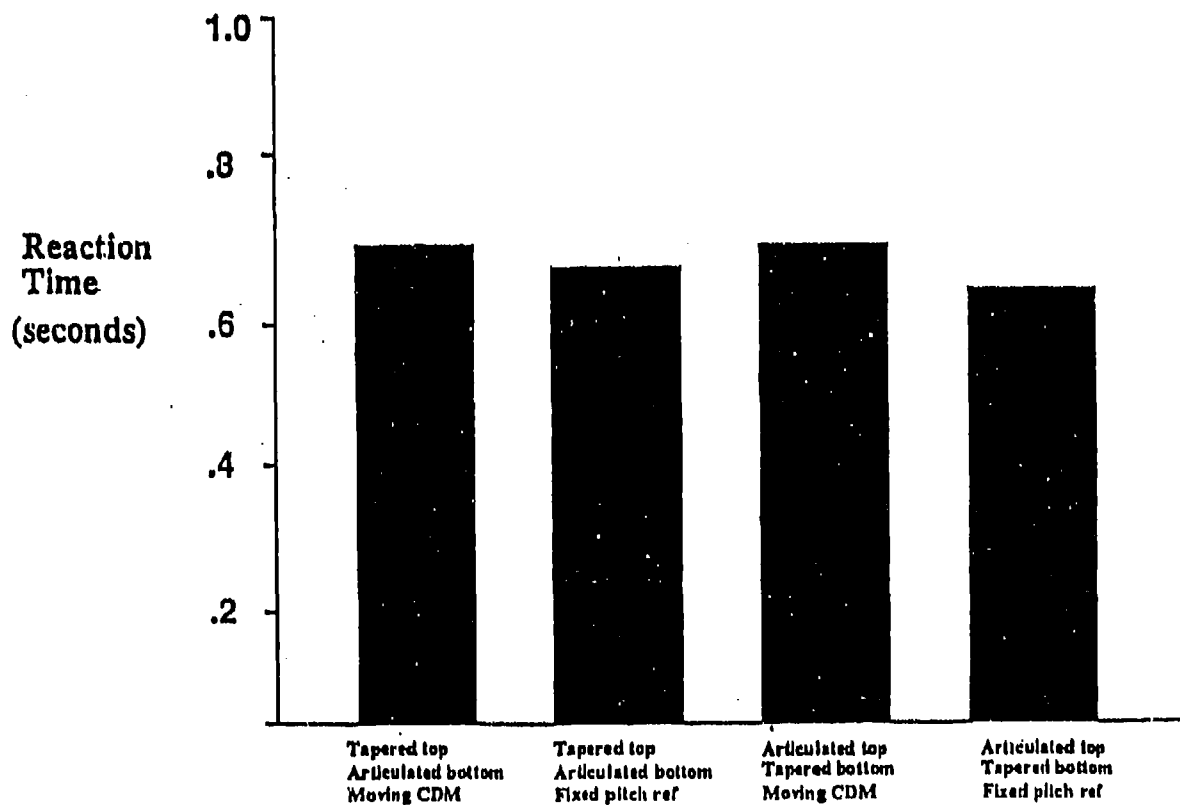

Figure 11. Reaction-time data for the four articulation configurations.

Ghost Horizon

Objective

This research effort examined two issues that remain unresolved in the development of a global attitude reference: the utility of a cue to indicate the direction of the actual horizon when the CDL horizon line is not within the HUD field of view (FOV), and the configuration of the bottom half of the CDL. A detailed description of the study can be found in Weinstein, Ercoline, and Bitton (1992).

Method

Subjects. Six HUD-experienced and six non-HUD-experienced military pilots volunteered to participate in the study. The average total flight time for all of the subjects was 2,870 hours; the HUD-experienced pilots had an average of 730 hours of HUD flying time. The pilots had experience in a number of HUD-equipped aircraft, including the A-10, F-14, F-15, F-16, F-18, and F-117.

Displays. The six HUD configurations evaluated in this study are illustrated in Figure 12. There were two factors examined: 1) the utility of the ghost horizon, and 2) the tapering of the CDL. The ghost horizon is a cue to the direction of the horizon when the 0-degree CDL line (HUD horizon) is not located within the HUD field of view. As the CDL moves vertically, and the horizon line reaches a set distance (determined by the HUD FOV size) from the edge of the instantaneous FOV, it is replaced by a ghost horizon line. The ghost horizon line, as originally conceived, is a dashed horizon line with "tepees" pointing upward, i.e., toward the sky (see Figure 12). The ghost horizon line extends across the entire FOV of the HUD, as does the conventional, solid, CDL horizon line. Once the true horizon is again located within the HUD FOV, the ghost horizon is replaced by the CDL horizon line (Bitton and Evans, 1991). In this study, the ghost horizon was evaluated to determine whether it can help pilots regain spatial orientation under conditions characterized by loss of attitude awareness (unusual attitude recovery situations).

The study also examined various line configurations for the bottom half of the CDL. The top half of the CDL contained solid, "articulated" lines. The lines pivoted at the inner corners and were angled at half the amount represented by that climb/dive line: e.g., the 40-degree line was articulated 20 degrees. A line was drawn at every 5 degrees of CDA. The CDL was drawn with linearly decreasing space between lines with increasing CDAs, so that the distance between the horizon line and the 5-degree line was 2.7 times the distance between the 85-degree line and the zenith or nadir symbol. Figure 12 illustrates the three types of lines that were evaluated for the bottom half of the CDL with and without a ghost horizon: tapered (became shorter with increasingly negative CDAs), non-tapered (same length for all CDAs), and reverse tapered (became longer with increasingly negative CDAs). The evaluation involved recovery from unusual attitudes in a flight simulator.

Task. The subjects were asked to perform 20 different unusual attitude recoveries with each of the 6 HUD configurations, which resulted in a total of 120 trials per subject. All trials were run during one session that lasted approximately 90 minutes. Subjects were also asked to complete a preference questionnaire at the completion of the session.

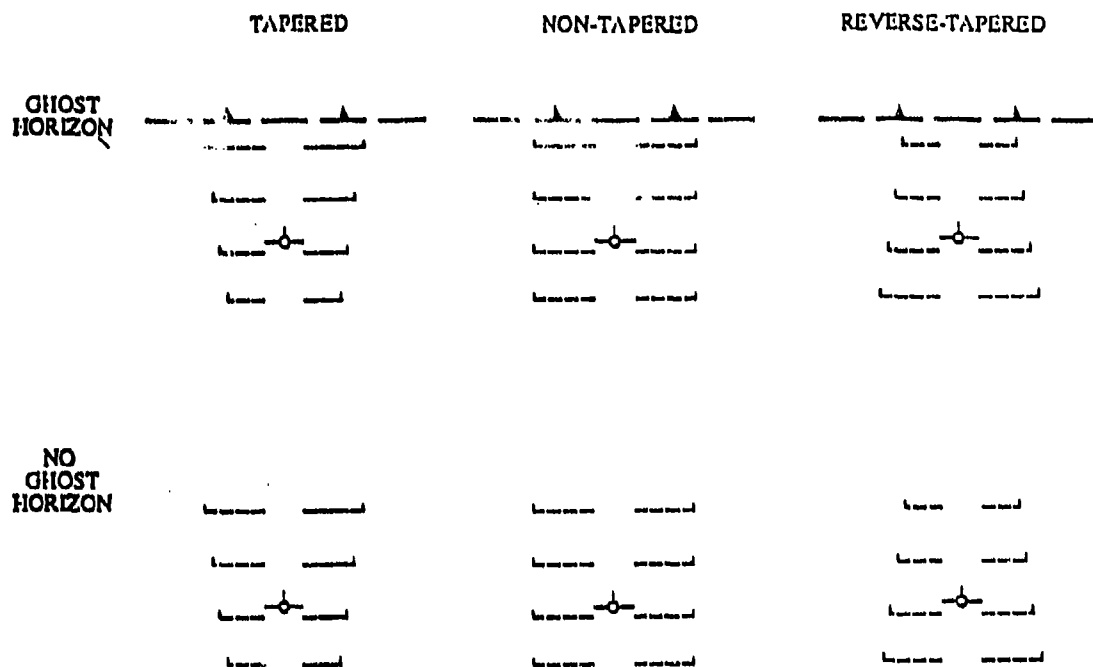

Figure 12. The 6 HUD climb/dive ladder configurations.

Results

ANOVAs were conducted on the accuracy, initial reaction time, and total recovery time parameters. There were no significant differences in performance or subjective evaluation due to prior HUD experience. Therefore, the data were collapsed across the two groups of pilots for analysis. The CDL line configuration (taper) did not affect unusual attitude recovery performance, nor did the pilots indicate a strong preference for any one CDL line configuration over any other, either with or without the ghost horizon. The mean accuracy (correctness) of the initial stick input, the mean initial reaction time, and the mean recovery time, as related to the three CDL line configurations, are shown in Table 1.

TABLE 1. Accuracy, Initial Reaction Time, and Total Recovery Time for the Three CDL Line Configurations Collapsed Across Ghost Condition.

Ladder Type	Accuracy (%)	Initial RT (s)	Total RT (s)
Tapered lines:	89	.74	11.45
Non-tapered lines:	89	.77	11.43
Reverse tapered lines:	90	.74	11.21

The accuracy (correctness) of the initial stick input, the mean initial reaction times, and the mean recovery times with respect to presence or absence of the ghost horizon are shown in Table 2. An ANOVA conducted on the accuracy data to assess the differences in recovery performance with and without the ghost horizon revealed a significant effect due to the horizon type ($F(1,11)=16.25, p < .01$). The ghost-horizon conditions resulted in significantly more accurate performance (95%) than did the non-ghost-horizon conditions (84%). The ANOVA on the initial reaction-time and total recovery-time data revealed no significant differences between conditions.

TABLE 2. Accuracy, Initial Reaction Time, and Total Recovery Time, With and Without the Ghost Horizon Collapsed Across the CDL Line Configuration.

Ghost Condition	Accuracy* (%)	Initial RT (s)	Total RT (s)
Ghost horizon:	95%	0.73 sec	11.35 sec
No ghost horizon:	84%	0.76 sec	11.38 sec

*The accuracy data were significant at $p < .05$.

The results of the preference survey revealed that 7 subjects had a preference for the ghost horizon, and 5 subjects preferred not to have it. Comments made by the pilots suggest that, although the ghost horizon is useful, the design of the horizon may not be optimal. Several subjects mentioned that they were confused by the "tepees" on the horizon line, because the "tepees" are sky pointers while the "ticks" on the CDL lines are horizon pointers. They suggested removing the "tepees," since the primary objective of the ghost horizon is to show the pilot the direction to the horizon. Several other subjects commented that the ghost horizon cluttered the display. If the "tepees" were removed, then the clutter on the display would be reduced. The "tepees" require a significant amount of computing power, and removing them would alleviate some of the computational load on the aircraft HUD. We feel confident that removing the "tepees" would not have diminished the performance benefits observed in this study because the subjective comments suggested that most pilots were unaware of the "tepees" or found them distracting.

Summary

In terms of accuracy of the initial stick input, the ghost-horizon conditions resulted in significantly better performance (about 11% better) than did the non-ghost-horizon conditions. The ghost horizon had no effect on initial stick input reaction time or total recovery time. The CDL line taper configuration did not affect accuracy, initial stick input reaction time, or total recovery time. These findings suggest that the ghost horizon is a useful aid to unusual attitude recovery performance, and may reduce spatial disorientation.

Vertical Velocity

Objective

There were two objectives in the current study: 1) determine if vertical-velocity-intensive flying tasks can be performed more accurately with an analog format for vertical velocity information than with a pure digital readout, and 2) determine if the incorporation of analog vertical velocity information with a digital readout is beneficial during these same tasks. A detailed description of the study can be found in Weinstein, Ercoline, Evans, and Bitton (1992).

Method

Subjects. Eight HUD-experienced, and twelve non-HUD-experienced, military pilots volunteered to participate in the study. One subject was not able to complete the study; therefore, his objective data were not included in the statistical analysis. However, the subject did fill out the questionnaire and his subjective data were used in the analysis. The average total flight time for all of the subjects was 2,800 hours, and the HUD-experienced pilots had an average of 670 hours of HUD flying time.

Displays. Subjects were required to perform several vertical velocity-intensive flying tasks with the five VVI configurations shown in Figure 13: 1) an arc around the altimeter beginning at the nine o'clock position and extending around the top or bottom of the altimeter to indicate positive or negative vertical velocities, respectively, 2) a digital readout located directly below the altimeter, with the two-letter identifier "vv" preceding the digits, 3) a combination of the arc and the digital readout, 4) circular moving-pointer dial similar to a head-down analog instrument with the addition of a digital readout in the center of the dial, and 5) boxed digits with a trend tape extending from the top or bottom to indicate positive or negative vertical velocities, respectively.

Task. Four instrument maneuvers were used to assess the five HUD configurations. During Task 1, subjects were asked to maintain straight and level flight at an altitude of 8500 ft, an airspeed of 360 knots, and a heading of 010 degrees. Task 2 was a vertical S alpha. Task 3 was a vertical S delta. See Chapter 3 for a detailed description of the vertical S tasks. Task 4 was another segment of straight and level flight at 8500 ft, 360 knots, and a heading of 010 degrees, but this segment included a sum-of-sinusoids perturbation.

Procedure. The subjects were asked to perform the four instrument flight procedures with each of the five HUD configurations, which resulted in a total of 20 trials per subject. The flight path marker was not presented on the HUD; accordingly pilots were instructed to use the pitch reference and vertical velocity information to perform the tasks. Practice vertical S maneuvers were flown by each subject. All trials were run during a 2-hour session. The four flight maneuvers were always flown in the order discussed above (Task 1, Task 2, Task 3, and Task 4).

The structure of the straight and level tasks and the vertical S tasks challenged the subjects to center their attention on different portions of the symbology; therefore, the VVI played a different role during the two types of tasks. For the straight and level tasks, subjects had to closely monitor the altimeter, and they used the VVI to detect changes in vertical velocity that would eventually result in changes in altitude if left unchecked. The pilot crosschecked airspeed and heading in order to maintain 360 knots and 010 degrees. The vertical S tasks required maintenance of a 1000 ft/min vertical velocity; thus the pilot's attention was focused primarily on the VVI while crosschecking the other symbology to maintain 360 knots, the 010-degree heading (vertical S alpha) or the 30-degree bank (vertical S delta), and altitude within the restrictions.

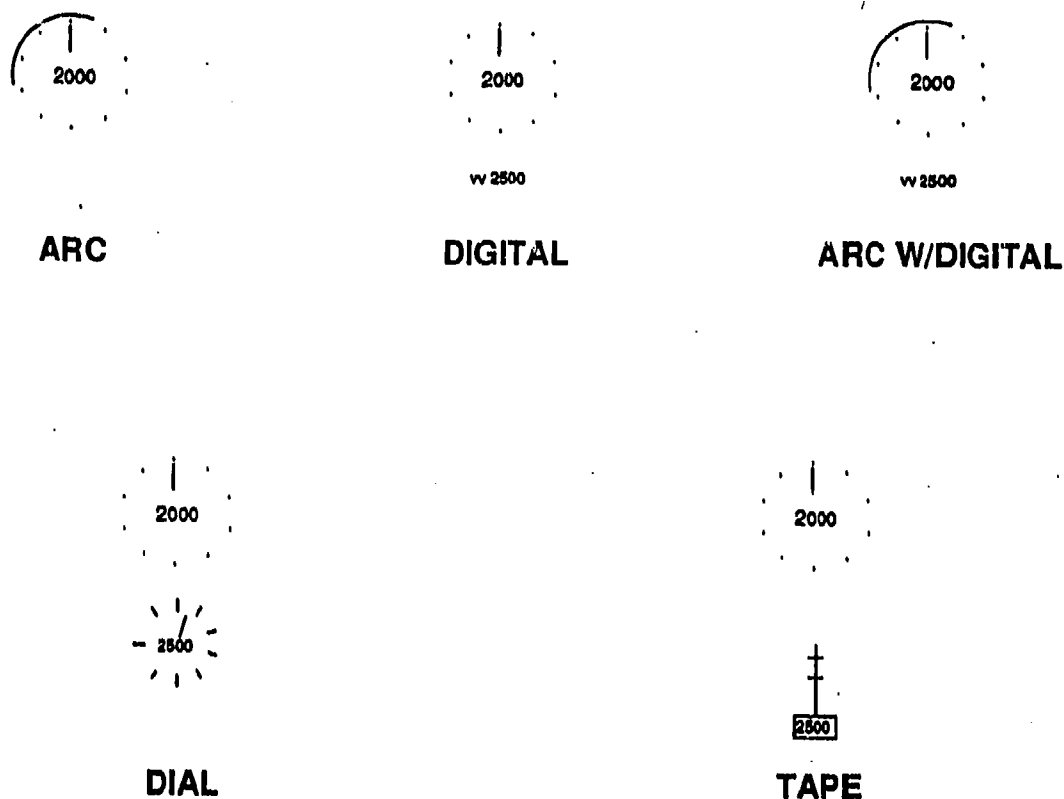

Figure 13. The five VVI configurations shown with the rotating pointer altimeter.

The primary factors in evaluating the quality of a VVI are how effectively the pilot can 1) maintain a predetermined vertical velocity and 2) detect and respond to deviations in vertical velocity with that display. Therefore, root mean squared error (RMSE) from a set vertical velocity was the primary measure used to evaluate the five HUD configurations. The dependent variables analyzed in the straight and level portions were the altitude, airspeed, and heading RMSEs. For the vertical S alpha task, the vertical velocity, airspeed, and heading RMSEs were examined; and for the vertical S delta task, the vertical velocity, airspeed, and bank RMSEs were analyzed. However, a secondary measure of the quality of a VVI is the reduction in pilot workload associated with that configuration relative to other configurations. In the current scenario a decrease in workload was assumed to be associated with an increase in the pilot's ability to maintain other flight parameters (i.e., altitude, heading, airspeed, bank). This relationship means that an improvement in the maintenance of these other flight parameters is expected with an increase in the quality of the VVI.

At the end of each task, subjects were asked to rate the effectiveness of each VVI display in helping him complete the task. Subjects responded with a numeric rating of "1" through "7" where "1" represented very ineffective and "7" was very effective.

Results

Of the 19 subjects who completed the objective data collection session, 8 had previous HUD experience and 11 had no prior HUD experience. Repeated measures ANOVAs were

conducted on the RMSE measures for vertical velocity, altitude, airspeed, heading, and bank for the four tasks as appropriate (e.g., RMSE for heading would be irrelevant during the vertical S delta task which requires maintenance of a 30-degree bank and no set heading). Performance measurements were not taken until the subject had stabilized the desired flight parameters for each task. HUD experience was used as a grouping factor for the ANOVAs, while HUD configuration and task type were used as within-subjects factors. There were no significant effects due to HUD experience; consequently, the data for the two groups were combined.

Objective data. The mean vertical velocity RMSE for the five HUD configurations and the two vertical S tasks are shown in Figure 14. Vertical velocity RMSE was analyzed for the vertical S tasks; there was a statistically significant main effect due to HUD configuration ($F(4,68)=17.57$, $p < .001$). A post hoc comparison revealed that performance with the arc and the arc with digital readout configurations was significantly better than performance with the other three configurations. A main effect due to task type was also significant ($F(1,17)=12.42$, $p < .01$). A marginally significant ($F(4,68)=2.57$, $p = .05$) interaction effect of HUD by task type was found.

A Bonferroni post hoc comparison revealed that the dial configuration resulted in less accurate performance on the vertical S delta task than it did on the vertical S alpha task. (Note that the .05 significance level was used for all post hoc tests.) The pattern of the interaction suggests that the maintenance of vertical velocity is consistently more accurate during the vertical S alpha task than during the vertical S delta task, and the pattern is similar for four of the five configurations. This pattern suggests that some attribute of the dial configuration may result in differential utility for that design depending on the task to be accomplished.

Altitude maintenance was only required during the straight and level portions of the experiment. Therefore, the altitude RMSE data were only analyzed for the two segments requiring straight and level flight. There was no display effect during the straight and level portion without perturbations (Task 1). Therefore, only the data obtained during Task 4 will be discussed. Figure 15 illustrates the statistically significant effect ($F(4,68) = 3.78$, $p < .01$) for altitude RMSE during the straight and level task with perturbations (Task 4). A Bonferroni post hoc comparison revealed that the arc and the arc with digital readout configurations resulted in significantly more accurate altitude control than did the digital configuration alone. The test also revealed that the arc display allowed for significantly more accurate altitude control than did the tape configuration. Airspeed maintenance was required during all four flight maneuvers. There was a statistically significant effect of task type; both vertical S tasks had a larger airspeed RMSE than did the straight and level segments ($F(3,68) = 21.32$, $p < .001$). However, there was no effect of VVI configuration on airspeed control.

Heading error was analyzed for the two straight and level tasks and the vertical S alpha task. There was a significant effect due to task type; the tasks including perturbations showed increased RMSE over the straight and level task without perturbations ($F(2,68) = 14.67$, $p < .001$). This finding is not surprising because the perturbations were designed to increase the difficulty level of the tasks.

Bank maintenance was required only during the vertical S delta. The RMSE in bank as a function of VVI configuration is shown in Figure 16. Although the overall error rates in bank angle were very small (approximately 2 degrees), there was a statistically significant effect due to VVI configuration. A Bonferroni post hoc comparison revealed that bank errors were significantly greater with the arc and the arc with digital readout than with the tape or digital readout. Although the difference is small, this finding may reflect a reduced crosscheck area that omits the bottom of

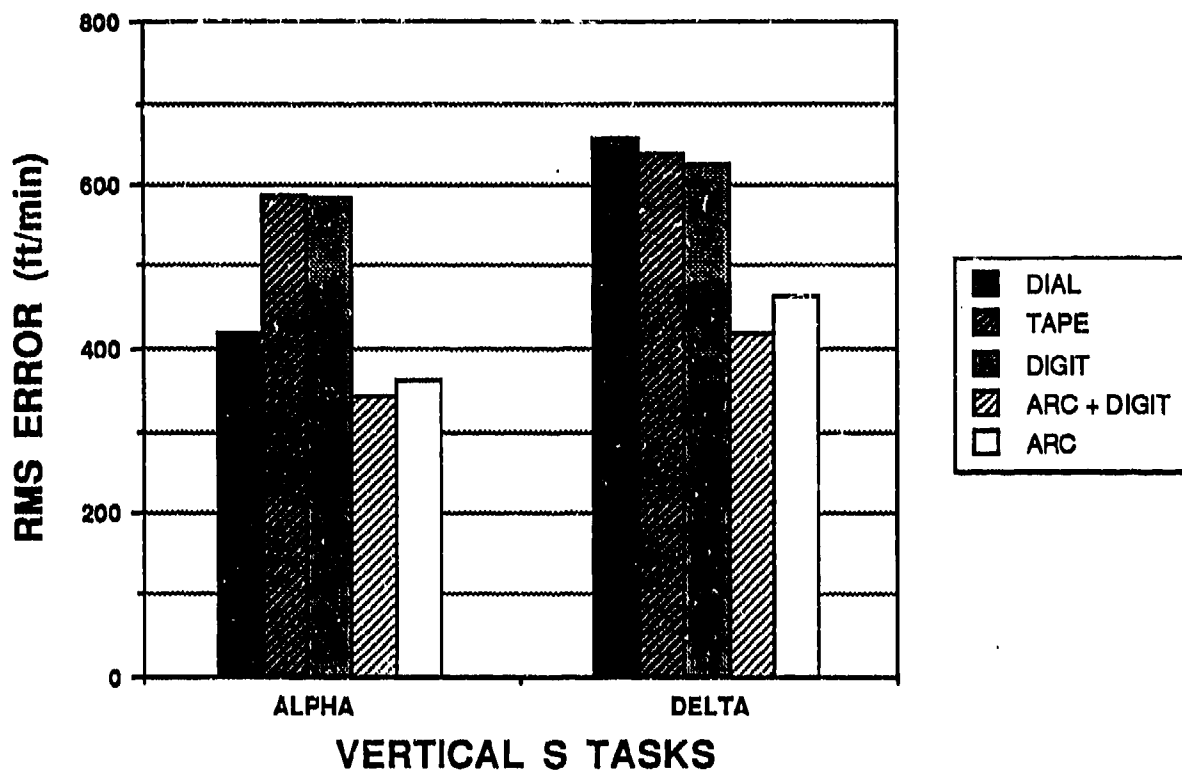

Figure 14. The mean vertical velocity RMSE for the five VVI configurations and the two vertical S tasks.

the HUD. As a consequence, the bank scale may be excluded from the pilot's crosscheck, and larger bank errors may be the result.

Subjective data. At the end of the session, each subject completed a preference questionnaire. Table 3 shows the mean ratings for the five displays. The results of that survey supported the objective findings: pilots preferred either configuration that included the altimeter arc (a design previously unknown to them) over the digital or tape configurations. An ANOVA was conducted on the ratings and revealed a significant main effect due to HUD type ($F(4,68) = 21.13$, $p < .001$). Bonferroni T tests (post-hoc comparison) revealed that the two arc configurations were preferred over the tape and digital VVIs. Preference for the dial was also significantly greater than that for the digital VVI. Non-parametric tests conducted on the subjective ratings revealed similar results.

Summary

The results clearly indicated that the altimeter arc with digital readout, and the altimeter arc alone, resulted in significantly more accurate maintenance of flight parameters (i.e., vertical velocity and altitude) than did the digital readout alone, the boxed digits with tape, or the dial. These findings suggest that analog vertical velocity information is useful on the HUD, particularly when it is located in close proximity to the altimeter.

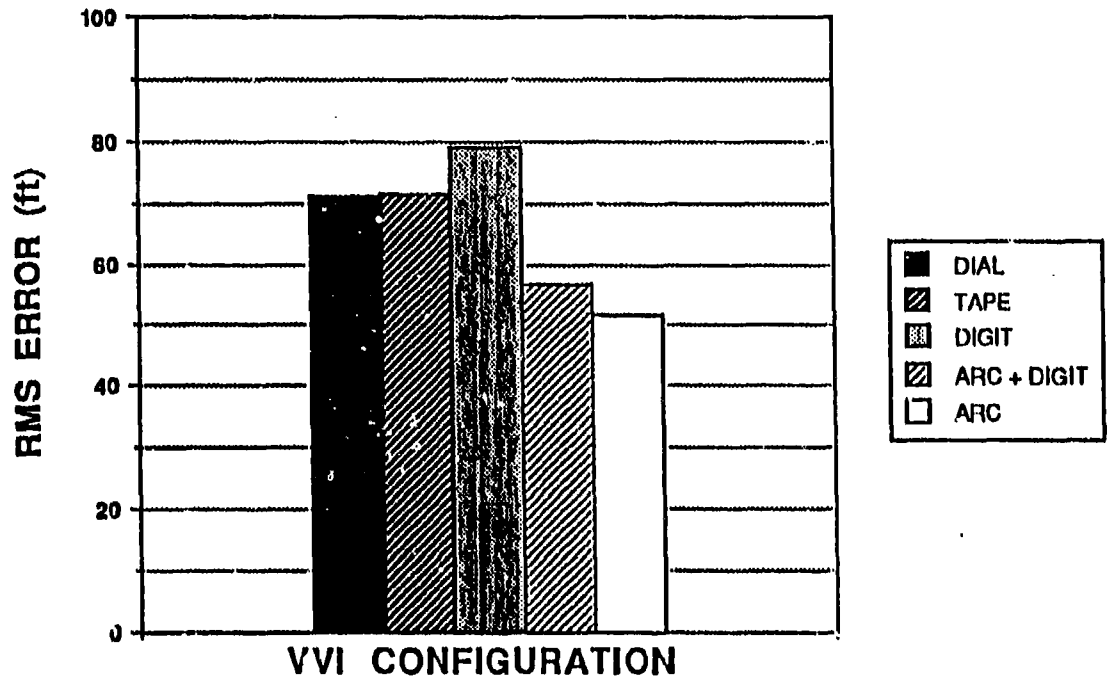

Figure 15. The RMSE altitude for the five VVI configurations during the straight and level task with perturbations.

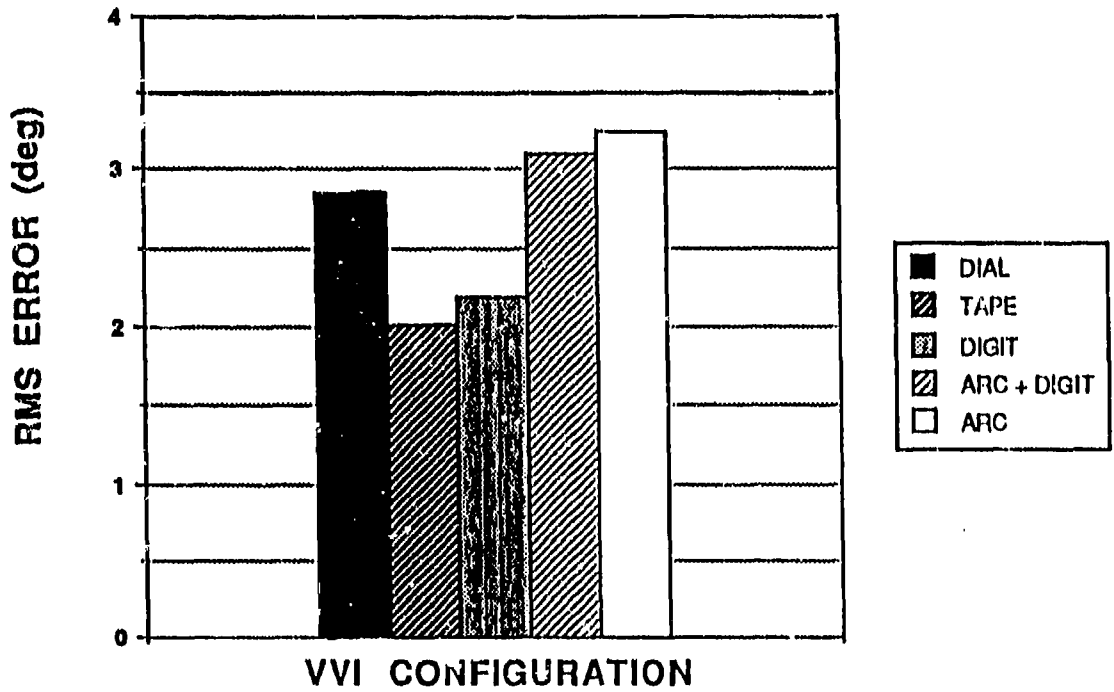

Figure 16. The RMSE in bank as a function of VVI configuration.

TABLE 3. Mean Subjective Ratings for the Five VVI Configurations. (A rating of "1" was highly unfavorable, and a rating of "7" was highly favorable.)

VVI CONFIGURATION					
	DIAL	TAPE	DIGIT	ARC + DIGIT	ARC
MEAN RATINGS	4.24	3.70	2.74	4.84	5.01

Energy Management Symbology

Objective

The objective of this evaluation was to determine the utility of longitudinal acceleration information and an angle-of-attack (AOA) indication as well as the optimal configuration for the presentation of this information of the HUD.

Method

Subjects. Four HUD-experienced, and five non-HUD-experienced, military pilots volunteered to participate in the study. The average total flight time for all of the subjects was 3,010 hours, and the HUD-experienced pilots had an average of 865 hours of HUD flying time. The pilots had experience in a number of HUD-equipped aircraft, including the A-10, F-15, and F-16.

Displays. The four energy management configurations are illustrated in Figure 17. A configuration similar to the commercially available Flight Dynamics Incorporated (FDI) energy management symbology consists of an AOA indicator, or worm, that extends from the wing of the CDM and increases in size with deviations from the designated AOA for an approach. The worm extending out the top of the wing indicates excessive airspeed and a resulting low AOA. Conversely, the worm extending from the bottom of the wing indicates a slow airspeed and a resulting high AOA. The longitudinal acceleration caret was mechanized the same way in the three configurations that included that information. The caret was located abeam of the CDM when the aircraft had no longitudinal acceleration. As airspeed increased, i.e., as the aircraft accelerated, the caret would move above the wing; and as the aircraft decelerated, the caret would move below the wing. The movement of the caret had a consistent control/display relationship with the movement of the throttle. As the throttle moved forward, the caret moved up on the display. The remaining three configurations represented AOA information by a bracket located next to the CDM. The configuration similar to the French Mirage 2000 symbology has two brackets located symmetrically on either side of the CDM. All three configurations were mechanized so that high AOA (low airspeed) is indicated by the bracket moving below the CDM. The acceleration caret and

AOA indicators were mechanized such that when the pilot was on the airspeed specified for the approach to landing, the indicators were centered next to the CDM.

Task. The subjects were asked to perform two ILS approaches with each of the four HUD configurations, which resulted in a total of 8 trials per subject. During one of the approaches with each configuration, subjects experienced a microburst (i.e., an updraft followed by a severe downdraft). The microburst occurred after localizer intercept, but prior to glideslope intercept. This unexpected change in energy state was reflected by the movement of the caret. The caret would begin to move up on the display indicating that the aircraft was accelerating, and then the caret rapidly moved down on the display indicating that the aircraft was decelerating. All trials were run during a two-hour session.

The primary factors in evaluating the quality of an energy management display in an approach to landing situation are how effectively the pilot can 1) maintain a predetermined course and glideslope and 2) detect and respond to deviations from the flight path with that display. Therefore, RMSE from course and glideslope were the primary measures used to evaluate the four HUD configurations. RMSE for airspeed, angle of attack, and acceleration were also measured. At the completion of the experiment, subjects were asked to evaluate the displays on a number of attributes.

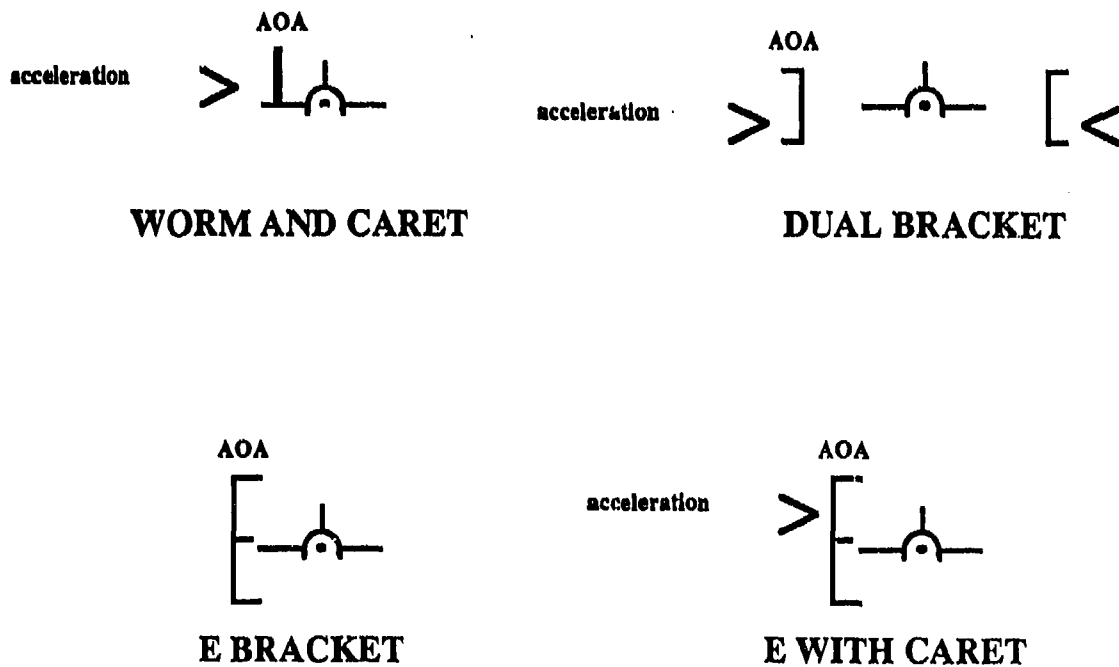

Figure 17. The four HUD energy management configurations.

Results

Figures 18, 19, 20, 21, and 22 illustrate the mean RMS deviations for acceleration, airspeed, AOA, glideslope and course, respectively, for a portion of the approach (2 miles to 1 mile out). There was a statistically significant effect on performance due to the configuration of the energy management cue, for airspeed, AOA, and glideslope deviations. For airspeed and AOA, performance with the worm and caret was significantly more accurate than performance with both "E" bracket configurations, which was in turn more accurate than performance with the Mirage configuration (airspeed, $F=13.37$, $p < .01$; AOA, $F=13.53$, $p < .01$). Glideslope performance with the worm and caret was significantly more accurate than performance with the Mirage configuration ($F=3.32$, $p < .05$). There were no differences between the "E" bracket configurations and the other two configurations for glideslope deviation. The course deviation data showed a similar pattern of results, although the differences were not large enough to reach statistical significance.

Summary

The worm and caret resulted in the most accurate performance on the simulated ILS task. The subjects responded to the microburst using more decisive stick and throttle movements with the acceleration caret. Therefore, the recommendation was made to include the worm angle-of-attack indicator and the acceleration caret (FDI configuration) with the standard symbology set.

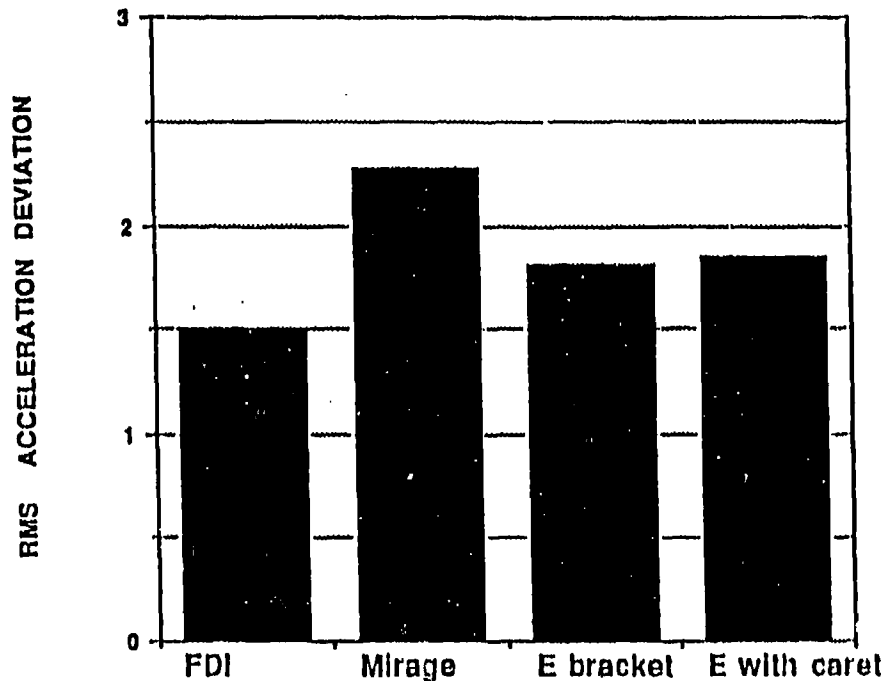

Figure 18. The RMS acceleration deviations for the four energy management configurations.

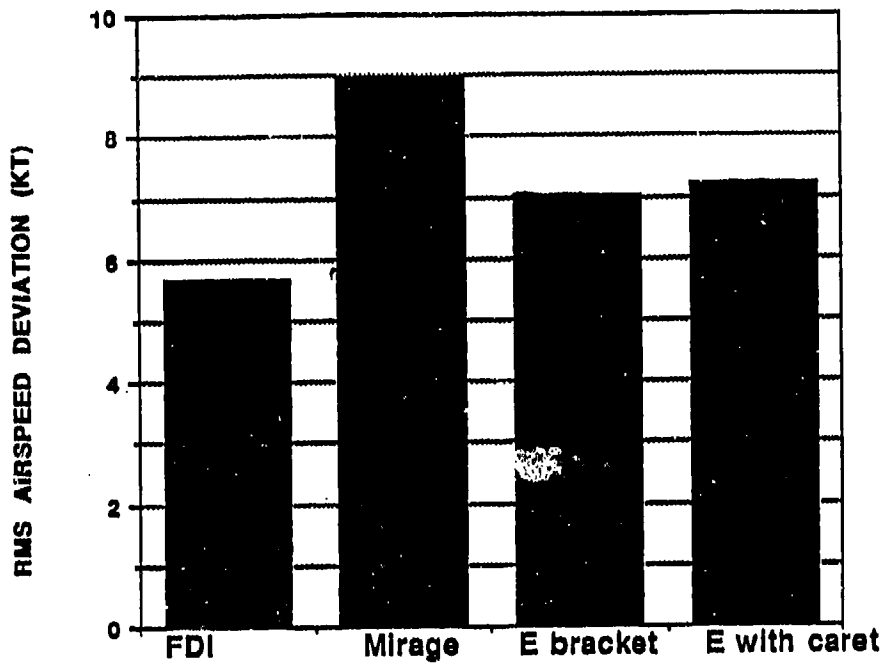

Figure 19. The RMS airspeed deviations for the four energy management configurations.

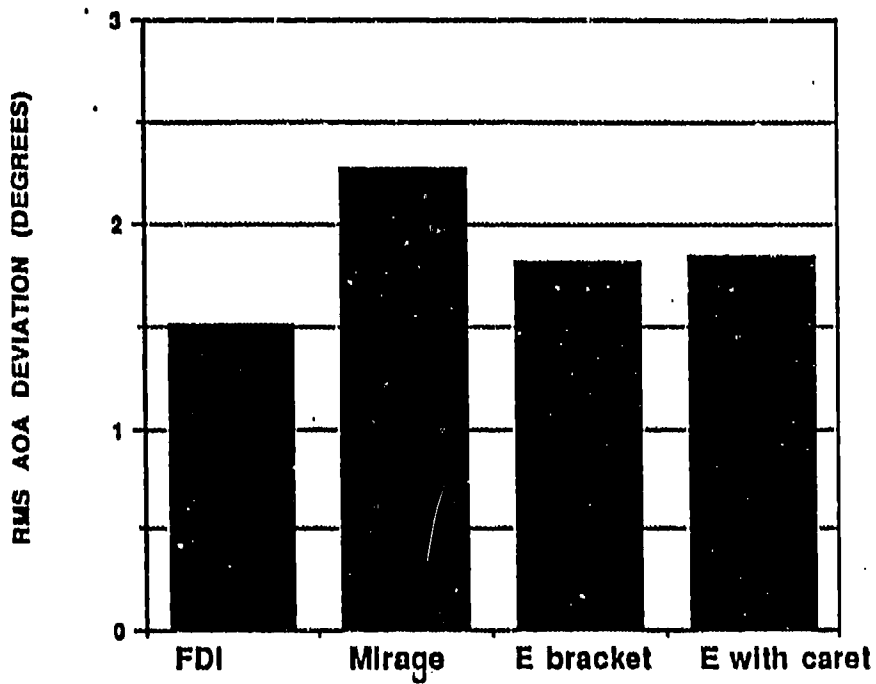

Figure 20. The RMS AOA deviations for the four energy management configurations.

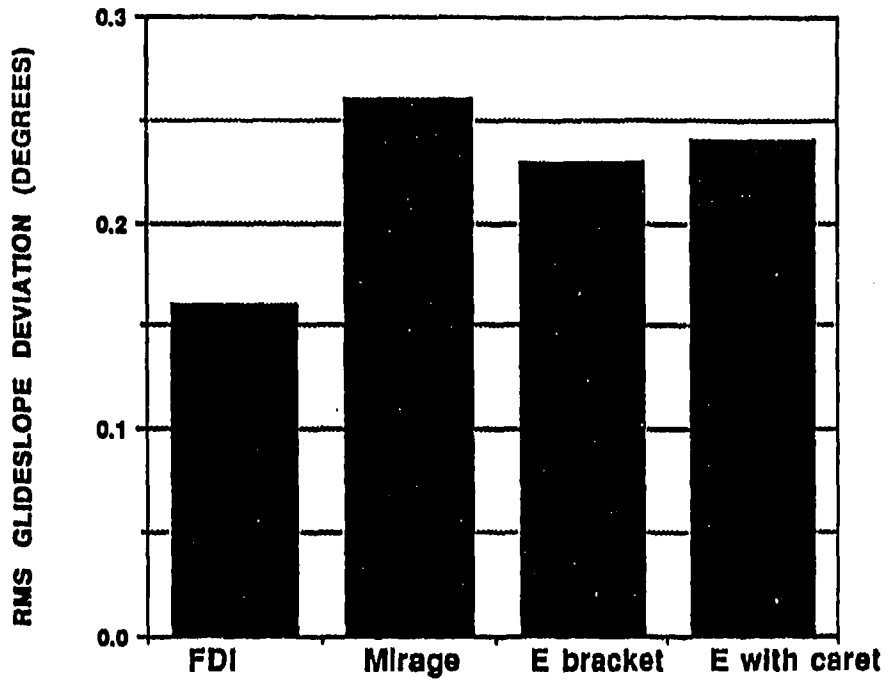

Figure 21. The RMS glideslope deviations for the four energy management configurations.

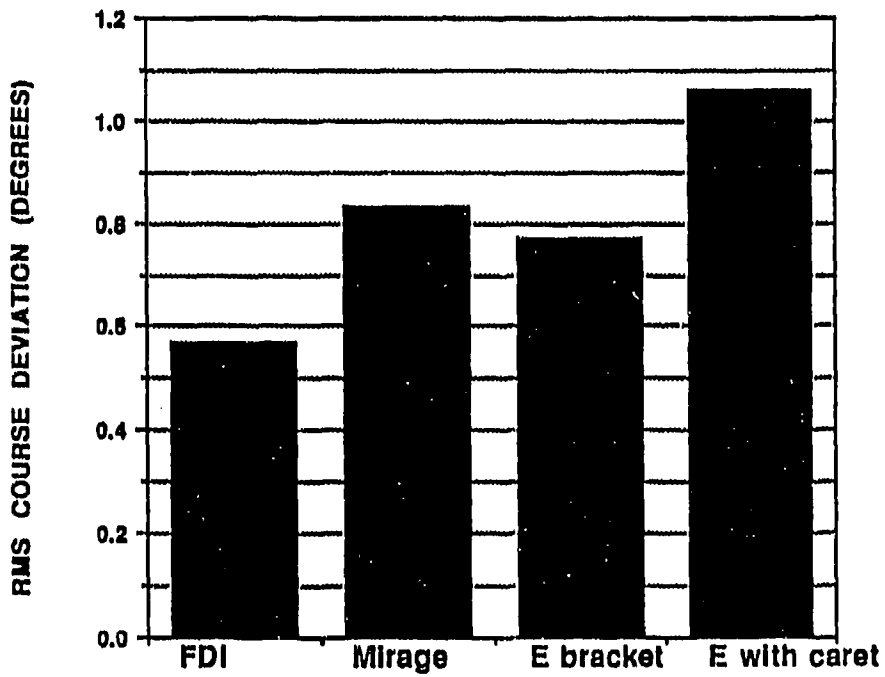

Figure 22. The RMS course deviations for the four energy management configurations.

CHAPTER V

FULL-SCALE SIMULATION AND INFLIGHT VALIDATION

Full-Scale Simulation

The direction from the Instrument Standardization Working Group, chaired by the Joint Cockpit Office (JCO), stated that the symbology set must be flight tested before it could be adopted by the USAF as a standard (Hughes, Hassoun, and Barnaba, 1993). Prior to the flight test, all of the symbology elements developed in the laboratories had to be integrated and examined as a unit. The decision was made to conduct a full-scale simulator study in the Crew Station Evaluation Facility (CSEF) at Wright-Patterson AFB, Ohio. Reasons for this approach were obvious: 1) a full-scale simulation is much less expensive per hour than a flight test; 2) as a result of the cost savings, more data can be collected, increasing the statistical power of the results; and 3) if the results of the simulator evaluation were unfavorable, the flight test could be delayed until the draft standard was modified.

The full-scale simulation was conducted in the CSEF F-16 high-fidelity simulator, which is capable of recording numerous variables under a wide variety of conditions. Twenty-three volunteer subjects participated in the evaluation that compared the HUD symbology to the head-down instrument suite of the F-16 A/B cockpit. The HUD was evaluated during precision instrument control tasks, unusual attitude recoveries, and ILS approaches. The HUD was found to be as good as the head-down instruments in the precision instrument control task and the unusual attitude recovery task, and better than the head-down instruments for the ILS approaches. A detailed description of the full-scale simulation study can be found in ASC-TR-93-5003, A Comparison of Head-Up and Head-Down Display Formats during Instrument Flying Tasks, (Hughes et al., 1993). The results indicated that the HUD could be used in place of head-down instruments. The next step was to validate the symbology set in flight.

Inflight Validation

Flight validation was a multi-lab/center effort in the HUD standardization project. The management and funding were supplied by the Joint Cockpit Office, while the NT-33A airplane used for the validation was contracted through the AFFTC to Arvin/Calspan Incorporated. The AFFTC was the organization responsible for conducting the flight test, and operational pilots were used as test subjects in addition to test pilots. The Armstrong Laboratory personnel helped develop the protocol and the IFC scheduled test subjects.

It is interesting to note that two flight validations were required. The first uncovered a mechanization problem missed during the full-scale simulation. Strong crosswinds at altitude, omitted during the simulation, drove the FPM and CDL to the extreme side of the HUD FOV. This problem, coupled with a tapering of the CDL in steep CDAs and a 2-second delay to transition the CDL to the pitch reference of the HUD, meant that certain unusual attitudes could be presented without any control information visible to the pilot. Consequently, the HUD was determined by the AFFTC to be unacceptable.

Several modifications to the symbology set were required. By caging the CDL, the ladder was visible under all flight conditions. The CSEF simulator confirmed the improvement afforded

by the modifications and the second symbology set went to inflight validation. Following the completion of the AFFTC flight validation, on April 9, 1992, a briefing was given by the chairman of the JCO to the Air Force Chief of Staff. The HUD, as specified in the flight test, was approved for certification for instrument flight. MIL-STD-1787A, Aircraft Instrument Symbology, will be updated with appropriate symbology design and mechanization guidelines, and with lessons learned during the entire evaluation process.

Beyond the USAF Standard

Even though some symbology issues may remain unresolved, the HUD can be used for instrument flight, and it permits even greater accuracy for precision instrument landings than does the F-16 instrument panel. The use of the HUD in military aircraft is rapidly becoming standard. Every new USAF aircraft scheduled to replace an existing aircraft has a HUD in the cockpit. Commercial aircraft companies are also conducting research and development programs to design HUDs for use in commercial aircraft.

Dryden and Tapia at General Dynamics is one group of military contractors undertaking similar efforts. They are concerned with increasing situational awareness in the F-16 and have written several articles examining alternative configurations for the HUD (Dryden and Tapia, 1990; Dryden, 1990). Their research efforts have also addressed the possibility of creating symbology allowing the HUD to be a single-source, primary flight reference. An optimal configuration for ILS symbology (Dryden and Tapia, 1990), as well as the use of vertical asymmetry of the CDL, has been proposed.

The studies described in this paper were never meant to define the conclusive HUD. They were designed to study current symbology and integrate the best of the available ideas. Along the way a few novel ideas were found and used, but most of the work dealt with concepts already developed. Symbology and mechanization concepts are listed in Appendix A with cross-references to the studies that contributed most to the final product.

The results of the symbology evaluation studies can be summarized:

1. In a dynamic environment, symbology used to display the "sky" portion of the world should be clearly and intuitively different from the "ground" symbology (vertical asymmetry of the CDL).
2. Altitude information displayed on round dials can be integrated into an instrument crosscheck more easily than tapes or digits (counter-pointers).
3. Vertical-velocity arc located in close proximity to the altimeter allows most efficient processing of vertical-velocity and altitude information (arc VVI).
4. Optimal attitude awareness can only be achieved when attitude information is visible at all times (caged CDL and ghost horizon).
5. Occlusion may still be a problem.
6. Inflight validation should follow any high-fidelity simulator study.

Now that a standard has been developed and validated, a baseline exists for comparison with new ideas. As new technology is introduced, display research is turning to the design of

symbology for head-mounted displays. These displays will undoubtedly play a significant role in future fighter cockpit development. However, until these displays are common in operational aircraft, the HUD will hold a position of prominence in the fighter cockpit. In response to the endurance of the HUD, the research community must continue to develop symbology and mechanization to improve spatial orientation and reduce the risk of accident.





References

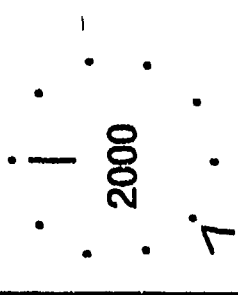
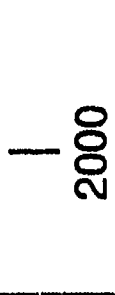
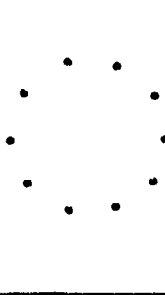
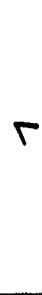

- Bitton, F, and Evans, R. (1991). Report on head-up display symbology standardization. USAF IFC Technical Report (USAF IFC-TR-91 01) Randolph AFB, TX.
- Burns, R, (1990). An evaluation of the F-16 instrument landing system landing display. USAF ASD Technical Report (ASD-TR-90-5001) Wright-Patterson AFB, OH.
- Deaton, J, Barnes, M, Lindsey, N, Greene, J, and Kern, J. (1989). The effect of windscreen bows and HUD pitch ladder on pilot performance during simulated flight. In: Proceedings of the Human Factors Society 33rd Annual Meeting. Human Factors Society; Santa Monica, CA.
- Department of Defense Military Standard 1787A, Aircraft Display Symbology, Ed: Hughes, T. (ASC/ENECS), Wright-Patterson AFB. 31 July 1987.
- Dryden, JB. (1990, April). Joe Bill answers his mail. Code One, 5(1), 16-20. General Dynamics Corporation, Fort Worth, Texas.
- Dryden, JB, and Tapia, M. (1990, July). Breakout with confidence. Code One, 5(2), 10-15. General Dynamics Corporation, Fort Worth, Texas.
- Ercoline, W, and Gillingham, K. (1990). Effects of variations in head-up display airspeed and altitude representations on basic flight performance. In: Proceedings of the Human Factors Society 34th Annual Meeting. Human Factors Society; Santa Monica, CA.
- Ercoline, W, Gillingham, K, Greene, F, and Previc, F. (1989). Effects of variations in head-up pitch-ladder representations on orientation recognition. In: Proceedings of the Human Factors Society 33rd Annual Meeting. Human Factors Society; Santa Monica, CA.
- Gold, T. (1968). The head-up display as a correlate to the visual world. In symposium proceedings Head-up displays. Human Factors Society Metropolitan Chapter, New York.
- Hall, JR, Stephens, CM, and Penwill, JC. (1989). A review of the design and development of the RAE Fast-Jet head-up display format. RAE FM WP(89)034.
- Hughes, T, and Lovering, P. (1990). A comparison of alternative head-up display symbol sets during approach and landing, navigation and unusual attitude recovery tasks. USAF Crew Station Evaluation Facility Technical Report (CSEF-TR-90-IFC-001) Wright-Patterson AFB, OH.
- Hughes, T, Hassoun, J, and Barnaba, J. (1993). A comparison of head-up and head-down display formats during instrument flying tasks. USAF Aeronautical Systems Center Technical Report (ASC-TR-93-5003) Wright-Patterson AFB, OH.
- McNaughton, G. (1985). Proceedings of the Aircraft Attitude Awareness Workshop. Flight Dynamics Laboratory. Wright-Patterson AFB, OH.
- Newman, R. (1980). Operational problems associated with head-up displays during instrument flight. Report No. AFAMRL-TR-80-116. Wright-Patterson AFB, OH.

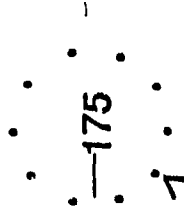

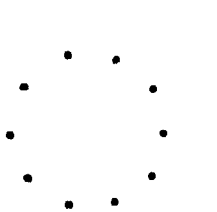
- Rastellini, M.M. (Ed.) (1986). Instrument Flying. Air Force Manual 51-37. Headquarters US Air Force, Washington, DC.
- Reising, J, Zenyuh, J, and Barthelemy, K. (1988). Head-up display symbology for unusual attitude recovery. In: Proceedings of the National Aerospace and Electronics Conference, Dayton, OH.
- Turner, A, and Hattendorf, P. (1992). Standardized Head-Up Display Symbology Evaluation. Air Force Flight Test Center Technical Report (AFFTC-TR-92-15) Edwards AFB, CA..
- Ward, G, and Hassoun, J. (1990). The effects of head-up display (HUD) pitch ladder articulation, pitch number location and horizon line length on unusual attitude recoveries for the F-16. USAF ASD Technical Report (ASD-TR-90-5008) Wright-Patterson AFB, OH.
- Weinstein, L, and Ercoline, W. (1991). Effects of variations in head-up display climb/dive ladder symbology. In: Proceedings of the Human Factors Society 35th Annual Meeting. Human Factors Society; Santa Monica, CA.
- Weinstein, L, and Ercoline, W. (1993). Energy management symbology and the standardization of cockpit display symbology. Aviation, Space, and Environmental Medicine, 64, (5), p. 464 (abstract).
- Weinstein, L, Ercoline, W, and Bitton, DF. (1992). The utility of a ghost horizon and climb/dive ladder tapering on a head-up display. In: Proceedings of the Human Factors Society 36th Annual Meeting. Human Factors Society; Santa Monica, CA.
- Weinstein, L, Ercoline, W, Evans, R, and Bitton, DF. (1992). Head-up display (HUD) symbology standardization and the utility of analog vertical velocity information during instrument flight. International Journal of Aviation Psychology, 2, (4).
- Zenyuh, J, Reising, J, McClain, J, Barbato, D, and Hartsock, D. (1987). Advanced head-up display (HUD) symbology: Aiding unusual recovery. In: Proceedings of the Human Factors Society 31st Annual Meeting. Human Factors Society; Santa Monica, CA.



APPENDIX A
HUD SYMBOLS AND ASSOCIATED MECHANIZATION



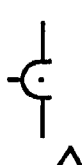

NAME	SYMBOL	MECHANIZATION	ATTRIBUTES	REFERENCES
ALTITUDE INDICATOR		<ul style="list-style-type: none"> • 360° EQUALS 1000 FT • CLOCKWISE INDICATES INCREASE 	<ul style="list-style-type: none"> • EASY TO INTERPRET • MINIMIZES REVERSALS • COMBINES VALUE AND TREND 	<ul style="list-style-type: none"> • SEE AIRSPEED REFERENCES
PARTS				
DIGIT / POINTER		<ul style="list-style-type: none"> • POINTS TO AND DISPLAYS ALTITUDE 		
DIAL		<ul style="list-style-type: none"> • DOTS AT 100 FT INCREMENTS 		
CARET		<ul style="list-style-type: none"> • COMMANDED ALT WITHIN 400 FT OF INDICATED ALT 		

NAME	SYMBOL	MECHANIZATION	ATTRIBUTES	REFERENCES
AIRSPEED INDICATOR		<ul style="list-style-type: none"> • 360° EQUALS 100 KTS • CLOCKWISE INDICATES INCREASE 	<ul style="list-style-type: none"> • EASY TO INTERPRET • MINIMIZES REVERSALS • COMBINES VALUE AND TREND 	<ul style="list-style-type: none"> • ERCOLINE AND GILLINGHAM • HUGHES AND LOVERING • HALL, STEPHENS, AND PENWILL • TAPIA, GENERAL DYNAMICS: HUMAN ENGINEERING TEST REPORT
PARTS	PARTS			
DIGIT / POINTER		<ul style="list-style-type: none"> • POINTS TO AND DISPLAYS IAS 		
DIAL		<ul style="list-style-type: none"> • DOTS AT 10 KT INCREMENTS 		
CARET		<ul style="list-style-type: none"> • COMMANDED IAS WITHIN 40 KTS OF IAS 		





NAME	SYMBOL	MECHANIZATION	ATTRIBUTES	REFERENCES
AOA IND WITH CLIMB/DIVE MARKER (CDM)		<ul style="list-style-type: none"> • GE/R DOWN • REFERENCED TO CONTROL SYMBOL 	<ul style="list-style-type: none"> • INTUITIVE • ATTACHED TO CONTROL SYMBOL 	<ul style="list-style-type: none"> • WL/XPX, UNPUBLISHED SURVEY, 1992 • WEINSTEIN AND ERCOLINE (1993)
WORM	<div style="border: 1px solid black; padding: 5px; text-align: center;">PARTS</div> 	<ul style="list-style-type: none"> • SHOWS HI AOA (LOW AIRSPEED) WHEN BAR EXTENDS BELOW CDM'S WING 		



NAME	SYMBOL	MECHANIZATION	ATTRIBUTES	REFERENCES
ENERGY MANAGEMENT INDICATORS WITH CDM		<ul style="list-style-type: none"> - REFERENCED TO CDM 	<ul style="list-style-type: none"> - CLOSE PROXIMITY TO CONTROL SYMBOL 	<ul style="list-style-type: none"> - WEINSTEIN AND ERCOLINE (1993)
CARET		<p>PARTS</p> <ul style="list-style-type: none"> - SHOWS EXCESS ENERGY WHEN ABOVE CDM 		



NAME	SYMBOL	MECHANIZATION	ATTRIBUTES	REFERENCES
BANK SCALE AND BANK INDICATOR WITH YAW		<ul style="list-style-type: none"> • REPRESENTS ROLL ABOUT LONGITUDINAL AXIS • REPRESENTS YAW ABOUT VERTICAL AXIS 	<ul style="list-style-type: none"> • TRADITIONAL PERSPECTIVE • REDUCES CLUTTER BY REMOVING UNNECESSARY PARTS OF BANK SCALE 	<ul style="list-style-type: none"> • TAPIA, GENERAL DYNAMICS: HUMAN ENGINEERING TEST REPORT
PARTS				
BANK SCALE		<ul style="list-style-type: none"> • BANK SCALE DRAWN ONLY WHEN INDICATOR WITHIN A SPECIFIED RANGE 		
BANK INDICATOR WITH YAW		<ul style="list-style-type: none"> • INCORPORATES YAW OF AIRCRAFT 	<ul style="list-style-type: none"> • CAN BE USED AS A SKY POINTER 	

NAME	SYMBOL	MECHANIZATION	ATTRIBUTES	REFERENCES
CLIMB / DIVE ANGLE INDICATOR WITH CDM		<ul style="list-style-type: none"> • CAGED 	<ul style="list-style-type: none"> • ELIMINATES LATERAL MOVEMENT 	<ul style="list-style-type: none"> • HUGHES AND LOVERING • HALL, STEPHENS, AND PENWILL • TAPIA, GENERAL DYNAMICS: HUMAN ENGINEERING TEST REPORT
		<ul style="list-style-type: none"> • QUICKENED 	<ul style="list-style-type: none"> • REDUCES VERTICAL MOVEMENT 	<ul style="list-style-type: none"> • WARD AND HASSOUN • ERCOLINE, GILLINGHAM, GREENE AND PREVIC • WEINSTEIN AND ERCOLINE (1991)
		<ul style="list-style-type: none"> • COMPRESSED 	<ul style="list-style-type: none"> • MAX INFO IN FOV FOR ATTITUDE AWARENESS 	<ul style="list-style-type: none"> • ZENYUJH, REISING, MCCLAIN, BARBATO, AND HARTSOCK • DRYDEN AND TAPIA
CLIMB / DIVE MARKER		<ul style="list-style-type: none"> • SHOWS CLIMB / DIVE ANGLE WRT CDL 		

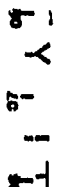
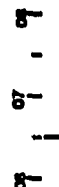

PARTS

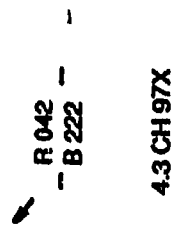

NAME	SYMBOL	MECHANIZATION	ATTRIBUTES	REFERENCES
PARTS (cont) CLIMB / DIVE ANGLE (CDA) INDICATOR				
FLIGHT PATH MARKER		<ul style="list-style-type: none"> • SHOWS DIRECTION OF AIRCRAFT WRT OUTSIDE WORLD 	<ul style="list-style-type: none"> • TRADITIONAL SYMBOL 	<ul style="list-style-type: none"> • WL/XPK, UNPUBLISHED SURVEY, 1992
CLIMB / DIVE LADDER	 	<ul style="list-style-type: none"> • CLIMB LINES BEND 1/2 OF CLIMB ANGLE • DIVE LINES TAPER (4:1) AS DIVE ANGLE INCREASES • COMPRESSES AT A RATE OF 4.4:1 AFTER 5° LINE; INCREASES FROM 5° TO 10° AFTER 30° OF CDA 	<ul style="list-style-type: none"> • FUNNEL TO HORIZON • EASY ROLL RECOGNITION • REDUCES "LADDERING" 	<ul style="list-style-type: none"> • SEE CLIMB / DIVE ANGLE INDICATOR WITH CDM REFERENCES
GHOST HORIZON	 	<ul style="list-style-type: none"> • BENDYS ON BOTTOM, STRAIGHT TAPERS ON TOP • APPEARS AS HORIZON LINE DEPARTS FOV 	<ul style="list-style-type: none"> • REDUCES CONFUSION BETWEEN UP AND DOWN • QUICK RECOGNITION OF HORIZON DIRECTION 	<ul style="list-style-type: none"> • WEINSTEIN, ERCOLINE, AND BITTON • TAPIA, GENERAL DYNAMICS: HUMAN ENGINEERING TEST REPORT

NAME	SYMBOL	MECHANIZATION	ATTRIBUTES	REFERENCES
HEADING INDICATOR		<ul style="list-style-type: none"> • 5:1 COMPRESSION • 30° DISPLAYED 	<ul style="list-style-type: none"> • MINIMIZES CLUTTER • PROVIDES ADEQUATE LEAD POINT 	<ul style="list-style-type: none"> • MIL STD 1787A
PARTS				
HEADING SCALE		<ul style="list-style-type: none"> • LONGER TICK MARKS AT 10° INCREMENTS. 		
CARET		<ul style="list-style-type: none"> • SHOWS COMMAND HEADING 	<ul style="list-style-type: none"> • REMINDER 	
GROUND TRACK MARKER		<ul style="list-style-type: none"> • SHOWS MAGNETIC GROUND TRACK 		

NAME	SYMBOL	MECHANIZATION	ATTRIBUTES	REFERENCES
BEARING INDICATOR WITH DISTANCE AND NAVAID		<ul style="list-style-type: none"> • SHOWS RELATIVE BEARING TO SELECTED NAVAID 	<ul style="list-style-type: none"> • TRADITIONAL PERSPECTIVE 	<ul style="list-style-type: none"> • HUGHES AND LOVERING
PARTS				
BEARING POINTER		<ul style="list-style-type: none"> • POINTS TO NAVAIDS IN PLAN VIEW 		
RADIAL AND BEARING	R 042 B 222	<ul style="list-style-type: none"> • DIGITAL REPRESENTATION 		
INDICES	--	<ul style="list-style-type: none"> • REFERENCE MARKS FOR $\pm 90^\circ$ OF AIRCRAFT HEADING 		
DME	4.3	<ul style="list-style-type: none"> • NAUTICAL MILES 		
NAVAID	CH 97X	<ul style="list-style-type: none"> • TACAN, VOR, WAYPOINT, ETC 		

NAME	SYMBOL	MECHANIZATION	ATTRIBUTES	REFERENCES
COURSE DEVIATION INDICATOR AND GLIDE SLOPE INDICATOR WITH CDM		<ul style="list-style-type: none"> • SHOWS RELATIVE ANGULAR DISPLACEMENT FROM CI AND GS 	<ul style="list-style-type: none"> • TRADITIONAL ADI-HSI PERSPECTIVE 	<ul style="list-style-type: none"> • HUGHES AND LOVERING • TAPIA, GENERAL DYNAMICS: HUMAN ENGINEERING TEST REPORT • BURNS
PARTS				
CDI		<ul style="list-style-type: none"> • MOVEMENT OF ARROW IN PLAN VIEW • DOTS REPRESENT DEVIATION FROM SELECTED COURSE • UNNECESSARY DOTS REMOVED 		
GSI		<ul style="list-style-type: none"> • MOVEMENT OF INDEXER IN PROFILE VIEW • DOTS REPRESENT DEVIATION FROM GS 		

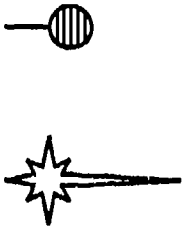
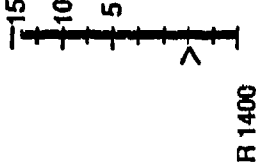
NAME	SYMBOL	MECHANIZATION	ATTRIBUTES	REFERENCES
FLIGHT DIRECTOR INDICATOR WITH CDM		<ul style="list-style-type: none"> • COMMANDS PITCH AND BANK INPUTS TO CORRECT DEVIATIONS FROM GS AND COURSE 	<ul style="list-style-type: none"> • COMMON DISPLAY USED IN UPT 	<ul style="list-style-type: none"> • HUGHES AND LOVERING • TAPIA, GENERAL DYNAMICS: HUMAN ENGINEERING TEST REPORT • BURNS
PARTS				
PITCH STEERING BAR		<ul style="list-style-type: none"> • FLY TO WRT CDM 		
BANK STEERING BAR		<ul style="list-style-type: none"> • FLY TO WRT CDM 	<ul style="list-style-type: none"> • ALSO USED FOR LOCALIZER ONLY APPROACHES 	

NAME	SYMBOL	MECHANIZATION	ATTRIBUTES	REFERENCES
MISCELLANEOUS SYMBOLS				
ZENITH AND NADIR INDICATORS		<ul style="list-style-type: none"> • LOCATED AT 90° OF CLIMB AND DIVE 	<ul style="list-style-type: none"> • POINTS TO HORIZON • EASY TO RECOGNIZE 	<ul style="list-style-type: none"> • HALL, STEPHENS, AND PENWILL
RADAR ALTITUDE INDICATOR	 <p>R 1400</p>	<ul style="list-style-type: none"> • TAPE MOVES WRT SCALE 	<ul style="list-style-type: none"> • INTUITIVE PERSPECTIVE 	<ul style="list-style-type: none"> • HUGHES AND LOVERING
PITCH REFERENCE		<ul style="list-style-type: none"> • FIXED WRT FUSELAGE REFERENCE LINE • VISIBLE WITH WEIGHT ON WHEELS 	<ul style="list-style-type: none"> • PROVIDES CONTROL REFERENCE FOR TAKEOFFS AND ROLL OUTS 	<ul style="list-style-type: none"> • TURNER AND HATTENDORF
TIME INDICATOR	00:03:22	<ul style="list-style-type: none"> • SELECTABLE MODES: TTG, CLOCK, ELAPSED TIME 	<ul style="list-style-type: none"> • REDUCES CLUTTER 	<ul style="list-style-type: none"> • TURNER AND HATTENDORF

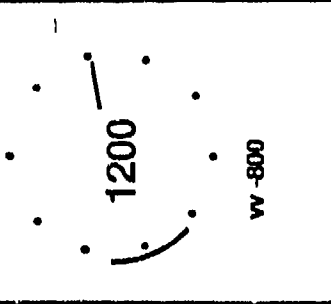
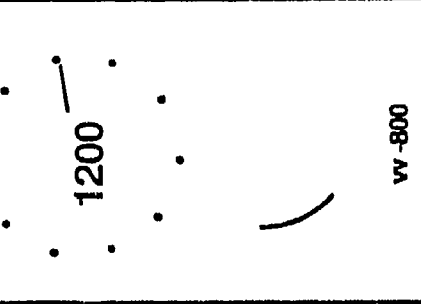
NAME	SYMBOL	MECHANIZATION	ATTRIBUTES	REFERENCES
VERTICAL VELOCITY INDICATOR		<ul style="list-style-type: none"> • CLOCKWISE MOVEMENT REPRESENTS INCREASE • NO INDICATION AT LEVEL FLIGHT • LOGARITHMIC SCALING 	<ul style="list-style-type: none"> • CLOSE PROXIMITY OF SIMILAR INFORMATION • REDUCES CLUTTER • GRAPHICALLY SHOWS TREND OF ALTITUDE 	<ul style="list-style-type: none"> • WEINSTEIN, ERCOLINE, EVANS AND BITTON
PARTS				
ALTITUDE INDICATOR		<ul style="list-style-type: none"> • DISCUSSED ON PREVIOUS PAGE • DIRECTION AND MAGNITUDE OF INDICATOR DISPLAYED IN DIGITAL FORMAT 		

COMPOSITE OF HUD SYMBOLS

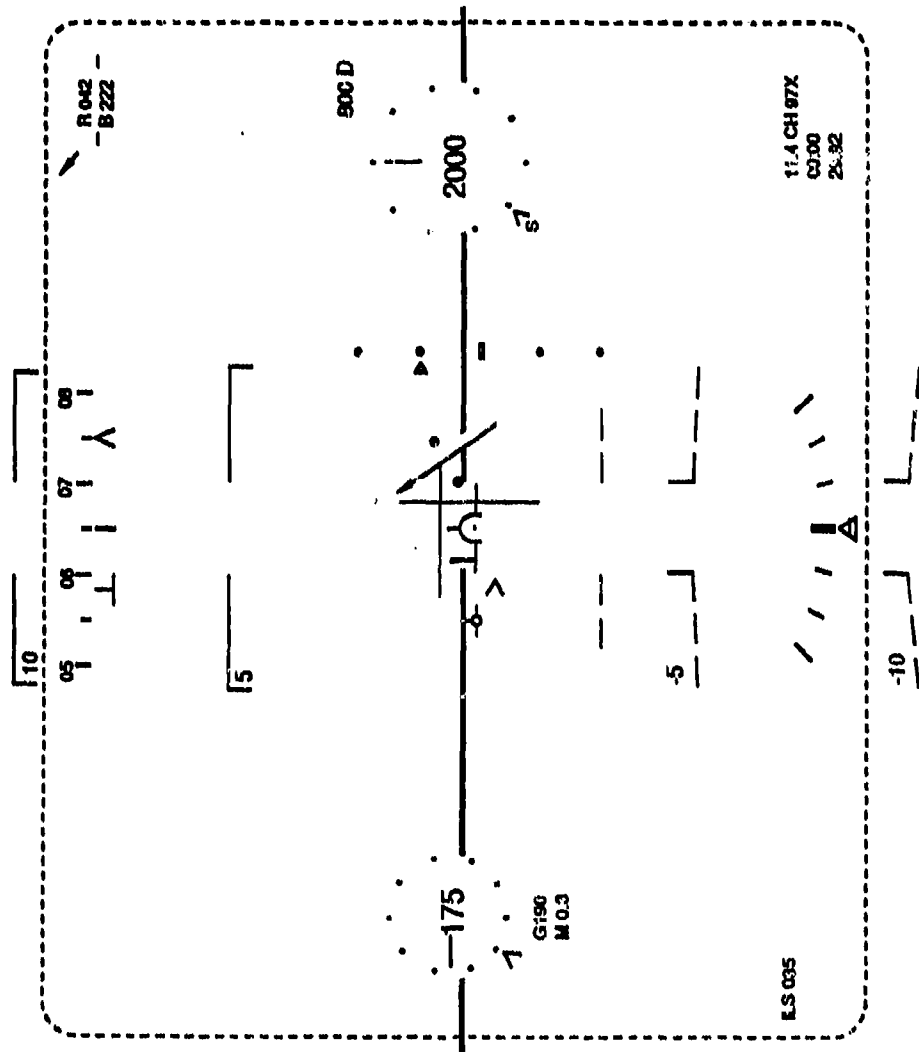

REFERENCES

- BITTON AND EVANS
- TURNER AND HATTENDORF

APPENDIX B
SIMPLIFIED GUIDE TO QUICKENING

SIMPLIFIED GUIDE TO QUICKENING

Visual displays in closed-loop systems generally display the current state of system variables. In systems with time lags, a view of the future state of the system is highly desirable. The advantages of displaying both the actual situation and a future or predicted situation to a human operator in a control loop are well proven (Jensen, 1981; Roscoe et al., 1981). The addition of prediction, or lead compensation, to flight displays improves the accuracy of control and may reduce pilot workload. Specific schemes for implementing lead compensation depend on the information being displayed, the control task, and the physical characteristics of the vehicle being controlled.

In a control task, the operator seeks to minimize the error between the actual vehicle state and the desired vehicle state. In the context of a head-up display (HUD), the desired vehicle state could be a heading or flight path. Lead compensation is used mostly in the display of climb/dive angle on the HUD. Thus, the desired aircraft state is a particular desired climb/dive angle read off the climb/dive ladder, while the actual climb/dive angle is read directly from the position of the climb/dive marker (CDM) against the climb/dive ladder. The difference between these two is the error. Once a suitable lead compensation term has been derived, it can be displayed to the pilot in two principal ways. The first method involves the display of a new symbol showing the predicted climb/dive angle, in addition to displaying the current climb/dive angle, known as a predictor display (Figure B-1A). In this display the pilot would aim to fly the predicted aircraft position to the desired climb/dive angle, but retains information on the current aircraft climb/dive angle.

The alternative approach is to display only the predicted aircraft climb/dive angle and not the actual climb/dive angle. This approach is known as quickening (Figure B-1B) and is the technique in use on current HUDs. In the quickened display the pilot aims to fly the quickened climb/dive marker to the desired climb/dive angle, but has no knowledge of the actual climb/dive angle. As the use of a quickened climb/dive marker (QCDM) does not add another symbol to the display, it helps to avoid clutter on the HUD and is preferable to the predictor display.

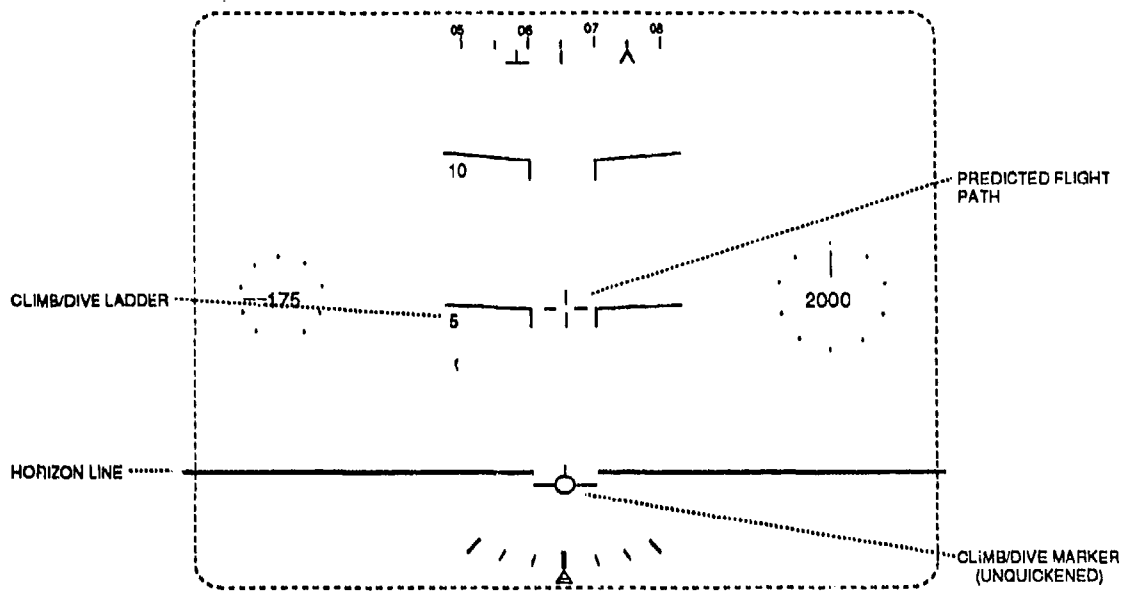

A

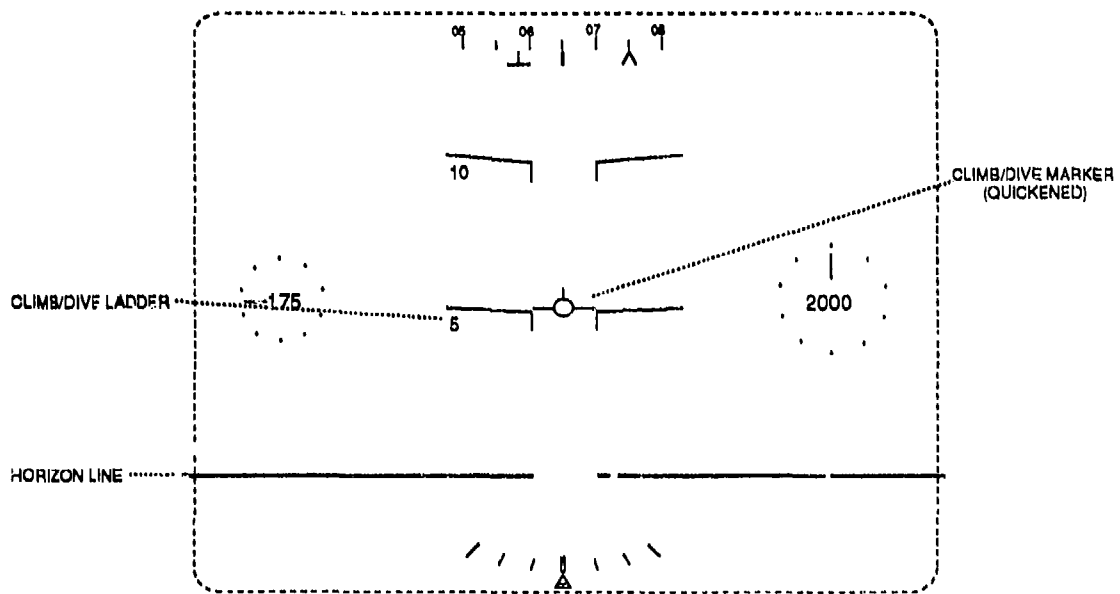

B

Figure B-1. Predicted climb/dive angle after a rapid 5 degree pullup. The climb/dive marker is unquicken and indicates the actual climb/dive angle of 0 degrees (A). In the quickened display only the predicted (quickened) flight path is shown (B).

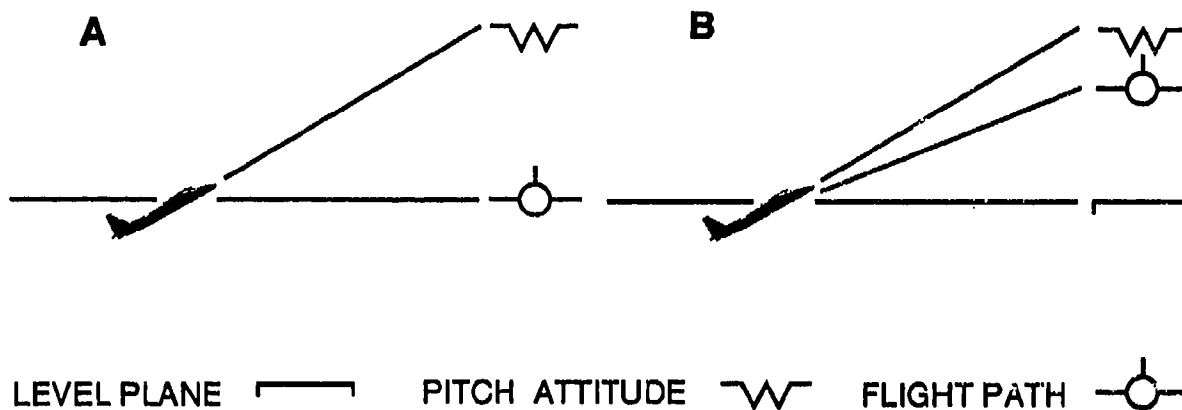

Figure B-2. The aircraft has just made a sudden increase in pitch from straight and level flight.

The pitch attitude has increased while the flight path has not changed (A). A short time (about 1 second) later the flight path angle has increased, while the pitch attitude remains the same (B). A quickened HUD would display the flight path angle shown in B immediately after the initial pitch change.

The major benefit of the QCDM is in keeping the CDM within the field of view of the HUD, making the display easier to use. To understand this concept consider Figure B-2. Here the pilot has made a sudden change in pitch from straight and level flight. While the aircraft responds rapidly in pitch, the flight path changes more slowly as aerodynamic forces act to overcome aircraft inertia. The pilot will see the climb/dive marker descend to the bottom of the HUD and, if the pitch change is large enough, peg at the bottom of the HUD. Assuming that the angle of attack remains approximately the same, if the pilot holds the new attitude, the new steady state flight path of the aircraft will have the same relationship to the longitudinal axis of the aircraft as before and the pilot will see the climb/dive marker come off the bottom of the HUD and settle in approximately the same position on the HUD as before the pitch change. If the QCDM is implemented appropriately, it can take into account the delay in aircraft response and will keep the QCDM in the field of view of the HUD. The QCDM will display pitch angle instantaneously after a sudden pitch change and

then becomes the CDM over a short period of time (approximately 1 second). The use of a QCDM makes the HUD behave more like an attitude indicator in response to rapid pitch changes.

To implement quickening, we need to process pitch information to produce a correction factor which is added to the climb/dive angle to display quickened climb/dive angle. This correction needs to decay towards zero with time. A function having these properties is known as a time washout filter. The Laplace transform of a high-pass filter is expressed in this manner:

$$\frac{\tau s}{1 + \tau s}$$

In this expression s is the Laplace complex frequency variable. τ is a time constant chosen to match the rate of decay of inputs to the filter to the flying characteristics of the aircraft. In a known configuration such as approach and landing this will be a constant value; while for normal flight where airspeed is varying and control effectiveness is varying with airspeed, the time constant will be dependant on airspeed. The derivation of the quickening function is shown in Figure B-3 (from Huff et al., 1990). Figure B-4 shows idealized plots of climb/dive angle, the output of the time

θ = pitch angle

α = angle of attack (AOA)

γ = flight path angle

$\hat{\alpha}$ = steady state AOA

$\hat{\gamma}$ = γ aircraft attains when $\alpha = \hat{\alpha}$

$\hat{\gamma}$ is the steady state value of γ and is the quickened flight path

$$\begin{aligned} \alpha &= \left[\frac{\tau s}{\tau s + 1} \right] \theta + \hat{\alpha} \\ \theta &= \gamma + \alpha = \gamma + \left[\frac{\tau s}{\tau s + 1} \right] \theta + \hat{\alpha} \\ \Rightarrow \theta - \hat{\alpha} &= \gamma + \left[\frac{\tau s}{\tau s + 1} \right] \theta \\ \theta &= \gamma + \alpha \\ \Rightarrow \gamma &= \theta - \alpha \\ \Rightarrow \hat{\gamma} &= \theta - \hat{\alpha} \\ \Rightarrow \hat{\gamma} &= \gamma + \left[\frac{\tau s}{\tau s + 1} \right] \theta \end{aligned}$$

Figure B-3. Derivation of quickening function.

washout filter (the quickener), and quickened flight path in response to a step change in pitch.

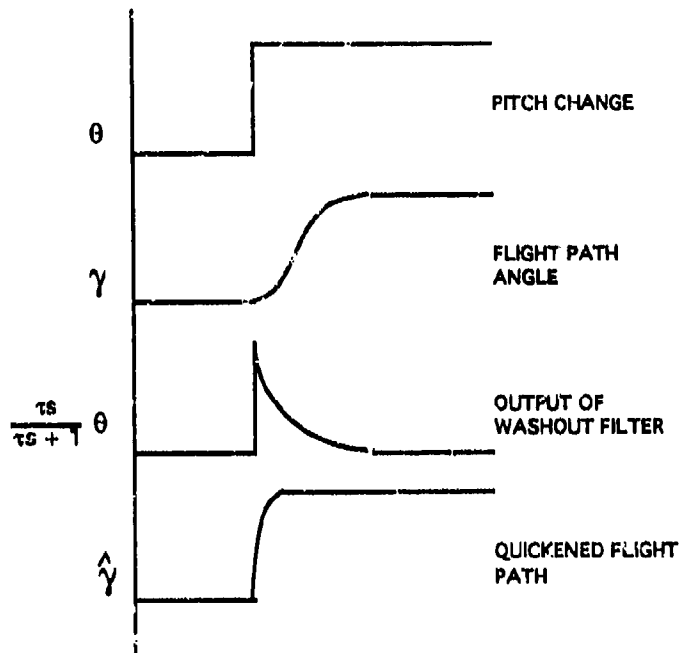

Figure B- 4. Effect of washout filter on flight path. The pitch change is the input to the filter. The output from the filter is added to the actual flight path to produce the quickened flight path. These curves are idealized responses to a step change in pitch.

For simulation purposes (and in most modern aircraft), the input and output of the filter will be in digital format; therefore the filter will also have to be implemented in digital format. The equations below (Figure B-5) express the filter as a difference equation which is readily converted to computer code. In the equations in Figure B-5 the time constant of the filter has been made dependent on airspeed. The two time constants τ_a and τ_b are determined by experiment (-0.325 and 385 in our simulation). Q1 is the 'quickener' used to apply lead compensation to the CDM and convert it to the QCDM. The CDM was caged in the HUDs studied in this investigation by setting the horizontal component of the flight path projection (transformation of flight path from earth-referenced coordinates to HUD coordinates) onto the HUD to zero in the same manner as used in

the RAE HUD (Hall, Stephens, and Penwill, 1989). The quickener is treated in the same manner,

τ_a	<i>quickening constant a</i>
τ_b	<i>quickening constant b</i>
τ_{min}	<i>minimum value of τ</i>
τ_{max}	<i>maximum value of τ</i>
V_t	<i>true airspeed (knots)</i>
σ	<i>ambient air pressure ratio</i>
Δt	<i>sampling interval (sec)</i>
θ_n	<i>current pitch angle (deg)</i>
θ_{n-1}	<i>last pitch angle</i>
ϕ	<i>roll angle (deg)</i>
<i>qgain1</i>	<i>gain for quick1</i>
<i>Q1</i>	<i>lead compensation term (quickener)</i>

$$\tau = \tau_a + \frac{\tau_b}{V_t \sigma} \quad \tau_{min} \leq \tau \leq \tau_{max}$$

$$a = \frac{2\tau}{\Delta t}$$

$$q_n = \frac{a-1}{a+1} q_{n-1} + \frac{a}{a+1} (\theta_n - \theta_{n-1})$$

$$quick1 = qgain1 \cdot q_n$$

$$Q1 = quick1 \cdot \cos(\phi)$$

Figure B-5. Difference equation for Q1.

leading to the $\cos(\phi)$ term in the above equations to produce Q1. The gain term (qgain1) is adjusted experimentally to a value which makes the QCDM behave in a subjectively acceptable manner (0.9 for powered approach mode and 0.5 for other flight modes). One of the problems in the implementation of Q1 is the behavior of the quickener as the pitch angle passes through the

zenith and nadir. At both of these points the sign of the pitch changes; thus, as pitch passes through the zenith, the value of pitch changes from +90 degrees to -90 degrees which produces a large step input to the filter leading to a sudden large inappropriate output.

The solution to this problem is to use a different method of quickening at high pitch angles based on body axis pitch rate, which can be taken directly from the on-board aircraft instrumentation and is aircraft referenced. This quickener is referred to as Q2. As the pitch goes through the zenith or the nadir, values for Q1 continue to be produced. The effect of the sign change will still affect the output of the filter when pitch returns to values where Q1 is used again. To allow the filter to settle quickly, the time constant of the filter is artificially set to a low value (0.3 in our simulation) as the pitch reaches high values. Thus, when the absolute value of pitch is less than 10 degrees, Q1 is used; when the absolute value of pitch is greater than 30 degrees Q2 is used, and between these values a linear blend of the two quickeners is used. Q2 is defined by:

$$Q2 = qgain2 \frac{\tau}{\tau_s + 1} q_a$$

where:

$qgain2$ = gain for Q2

q_a = body axis pitch rate (deg/sec)

Again this Laplace form needs to be expressed as a difference equation for use in a digital computer, as set out below.

$$qf_n = qf_{n-1} + (1 - e^{-\frac{\tau}{T_s}})(q_a - qf_{n-1})$$

$$Q2 = qgain2 \cdot qf_n \cdot \tau$$

A gain factor ($qgain2$), again optimized by experiment, is also applied to this filter (0.5 was used in our simulation). In practice $qgain2$ is usually set to the $qgain1$ value. Q2 offers an additional benefit to the pilot. When high pitch rates or high-G maneuvers are encountered, the angle of attack of the aircraft can increase, sometimes to quite large values. The Q1 lead compensation filter is based on the angle of attack returning to approximately the same steady state value before and

after a pitch change. When a high angle of attack is sustained, if Q1 were to be used, pilots would tend to overshoot the desired climb/dive angle on completion of the maneuver (Buell, 1991). The pitch rate lead filter can be adjusted to overcome this problem. It is for this reason that Q1 is used at pitch angles of less than 10 degrees, the range of values that would be encountered during approach. In this flight mode movement relative to the runway is important; hence Q1, which is driven by pitch, is used because pitch is earth referenced. During other flight modes where high pitch values and pitch rates are encountered, Q2 is used.

Acknowledgments

Mr G. K. Kessler, Naval Air Test Center, Patuxent River, Maryland for the derivation of the quickening equations.

Mr Tom Hughes, Crew Station Evaluation Facility, ASC/ENEC for the computer code to implement quickening.

References

Buell, C. G. (1991, December). IFS HUD Mechanization Groundwork. ASD-TR-IFS-XXX.

Hall, J. R., Stephens, C. M., & Penwill, J.C. (1989, July). A Review of the Design and Development of the RAE Fast-Jet Head-Up Display Format. RAE FM WP(89)034.

Huff, R. W., & Kessler, G. K. (1990). Enhanced Displays, Flight Controls, and Guidance Systems for Approach and Landing. In: Aircraft Ship Operations. AGARD Conference Proceedings 509 pp8-22.

Jensen, R.J. (1981). Prediction and Quickening in Perspective, Flight Displays for Curved Landing Approaches. Human Factors. 23(3), pp 355-363.

Roscoe, S. N., Corl, L., & Jensen, R.S. (1981). Flight Dynamics Revisited. Human Factors. 23(3). pp 341-353.