

ARMY RESEARCH LABORATORY



Practices and Standards in the Construction of BRL-CAD Target Descriptions

Paul H. Deitz
Keith A. Applin

ARL-MR-103

September 1993

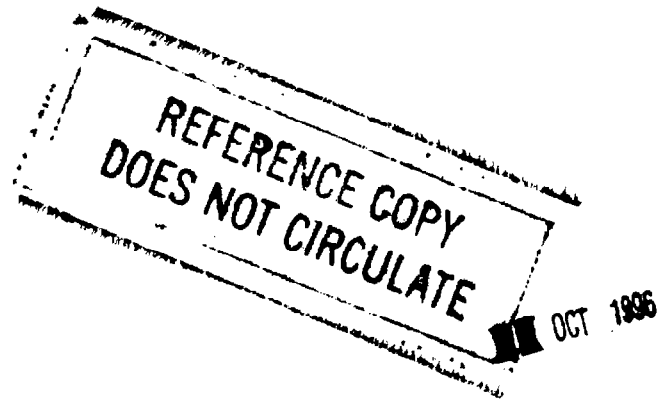

NOTICES

Destroy this report when it is no longer needed. DO NOT return it to the originator.

Additional copies of this report may be obtained from the National Technical Information Service, U.S. Department of Commerce, 5285 Port Royal Road, Springfield, VA 22161.

The findings of this report are not to be construed as an official Department of the Army position, unless so designated by other authorized documents.

The use of trade names or manufacturers' names in this report does not constitute indorsement of any commercial product.

REPORT DOCUMENTATION PAGE			Form Approved OMB No. 0704-0188	
Public reporting burden for this collection of information is estimated to average 1 hour per response, including the time for reviewing instructions, searching existing data sources, gathering and maintaining the data needed, and completing and reviewing the collection of information. Send comments regarding this burden estimate or any other aspect of this collection of information, including suggestions for reducing this burden, to Washington Headquarters Services, Directorate for Information Operations and Reports, 1215 Jefferson Davis Highway, Suite 1204, Arlington, VA 22202-4302, and to the Office of Management and Budget, Paperwork Reduction Project (0704-0188), Washington, DC 20503.				
1. AGENCY USE ONLY (Leave blank)	2. REPORT DATE September 1993	3. REPORT TYPE AND DATES COVERED FINAL - AUG 92 TO MAY 93		
4. TITLE AND SUBTITLE Practices and Standards in the Construction of BRL-CAD Target Descriptions			5. FUNDING NUMBERS PR: 1L162618AH80	
6. AUTHOR(S) Paul H. Deitz, Keith A. Applin				
7. PERFORMING ORGANIZATION NAME(S) AND ADDRESS(ES) U.S. Army Research Laboratory ATTN: AMSRL-SL-B Aberdeen Proving Ground, MD 21005-5068			8. PERFORMING ORGANIZATION REPORT NUMBER	
9. SPONSORING/MONITORING AGENCY NAME(S) AND ADDRESS(ES) U.S. Army Research Laboratory ATTN: AMSRL-OP-CI-B (Tech Lib) Aberdeen Proving Ground, MD 21005-5066			10. SPONSORING/MONITORING AGENCY REPORT NUMBER ARL-MR-103	
11. SUPPLEMENTARY NOTES This paper was presented at the BRL-CAD Users Conference 4-6 November 1992, held in Baltimore, MD.				
12a. DISTRIBUTION / AVAILABILITY STATEMENT Approved for public release; distribution unlimited.			12b. DISTRIBUTION CODE	
13. ABSTRACT (Maximum 200 words) BRL-CAD is a Government-developed geometric modeling system designed to support all aspects of the vulnerability/lethality (V/L) analysis field. In this report, we present a general overview type of approach to geometric modeling with BRL-CAD. The important link between the intended application/analysis and the specific requirements on the geometric model is discussed. An approach to effective BRL-CAD database management, based on the design of the database, is presented. We also suggest some basic naming conventions that have proven successful for armored systems. Finally, a general philosophy of geometric modeling and a modeling plan to accomplish any project are presented.				
14. SUBJECT TERMS Geometric modeling, BRL-CAD, solid modeling, target description, combinatorial solid geometry, vulnerability, models			15. NUMBER OF PAGES 52	
			16. PRICE CODE	
17. SECURITY CLASSIFICATION OF REPORT Unclassified	18. SECURITY CLASSIFICATION OF THIS PAGE Unclassified	19. SECURITY CLASSIFICATION OF ABSTRACT Unclassified	20. LIMITATION OF ABSTRACT UL	

Intentionally Left Blank

CONTENTS

1.	INTRODUCTION.....	1
2.	BACKGROUND.....	1
	2.1 Vulnerability/Lethality Assessments.....	1
	2.2 Combinatorial Solid Geometry.....	2
	2.3 Ray-Tracing.....	3
	2.4 BRL-CAD.....	5
3.	ANALYSES AND GEOMETRY REQUIREMENTS.....	5
	3.1 Nuclear Assessment.....	6
	3.2 Compartment Level.....	6
	3.3 Component Level - Parallel Ray.....	9
	3.4 Component Level - Point Burst.....	9
	3.5 SPARC.....	15
	3.6 SAR Signature.....	15
	3.7 IR Signature.....	17
4.	MANAGING BRL-CAD DATA FILES.....	18
	4.1 Data File Structure.....	19
	4.2 Creating Hierarchies.....	22
	4.3 Some Conventions.....	23
5.	MODELING PHILOSOPHY.....	24
6.	SUMMARY.....	25
7.	REFERENCES.....	27
	DISTRIBUTION LIST.....	29

Intentionally Left Blank

LIST OF FIGURES

Figure 1.	Manual Shotlines From Engineering Drawings.....	2
Figure 2.	Sample CSG Primitives.....	3
Figure 3.	Examples of Boolean Operations.....	4
Figure 4.	Ray-Tracing a Simple Region.....	4
Figure 5.	Exterior of a Compartment-Level Description....	7
Figure 6.	Air Regions Representing Internal Compartments.....	8
Figure 7.	Interior of a Compartment-Level Description....	8
Figure 8.	Exterior of a Component-Level Description.....	10
Figure 9.	Interior of a Component-Level Description.....	10
Figure 10.	Compartment-Level and Component-Level Gun System.....	11
Figure 11.	Compartment-Level and Component-Level Fuel System.....	12
Figure 12.	Compartment-Level and Component-Level Electrical System.....	13
Figure 13.	Compartment-Level and Component-Level Power Train.....	14
Figure 14.	Example of a SAR-Level Target Description.....	16
Figure 15.	Example of a SAR-Level Target Description.....	17
Figure 16.	Nodes Converted From BRL-CAD Geometry.....	18
Figure 17.	Sliced Turret to Produce Different Normals.....	19
Figure 18.	High Detailed Individual Component Modeling....	20
Figure 19.	Model of a Corps Command Post.....	21
Figure 20.	The BRL-CAD Hierarchical Data Structure.....	22

Intentionally Left Blank

1. Introduction

The **Ballistic Vulnerability Lethality Division (BVLD)**,* formerly known as the Vulnerability Lethality Division of the **Ballistic Research Laboratory (BRL)**, has been involved in geometric modeling for four decades. From the very beginning, geometric modeling has been incessantly tied to the vulnerability/lethality (V/L) field. In fact, geometric modeling in the Army was specifically developed to support V/L assessments, and its subsequent evolution has continually been driven by the V/L requirements. With this direct connection to the V/L field, the development cycle of geometric modeling at the BVLD has certainly been atypical. Most other modern geometric modeling systems have their roots in the mechanical drafting field, and have subsequently been tied to the design/manufacturing environment. Thus, to understand the development of geometric modeling at the BVLD, one must first consider the history of the V/L analysis field.

2. Background

2.1 Vulnerability/Lethality Assessments

The vulnerability of a system is a measure of that system's susceptibility to damage when attacked by a particular threat mechanism. Lethality, on the other hand, considers the reciprocal, and estimates the damage a threat inflicts on a particular target. The earliest attempts at V/L assessments were concerned with tanks being attacked by direct fire weapons, and relied heavily on subjective judgement. The major concern was perforation of the armor; hence, the only geometric information needed was armor thickness and obliquity angle. The penetration capability of the attacking munition was matched against the armor. If perforation occurred, then estimates were made concerning damage and residual system combat capability. Methodology soon began to emerge, however, and by the late 1950s, computer codes existed to estimate damage sustained by armored vehicles attacked by direct fire munitions.

These early V/L analysis computer codes considered large numbers of shot locations on a target from several attack aspects. For each attack azimuth, shot locations were evaluated for a grid completely covering the target. The geometric information required was a formatted file containing a sequential listing of information about each component encountered for each grid cell (or shot location). The required information included the name of the component, line-of-sight thickness, entrance and exit obliquity angles, and the type of material. This information, known as *shotline* data, was manually derived. For each attack direction, a 4-inch grid was physically drawn over the appropriate engineering

* The BVLD is one division of the **Survivability Lethality Analysis Directorate (SLAD)**, an element of the **Army Research Laboratory (ARL)**.

drawing. Then, on a cell-by-cell basis, the shotline data were estimated (see **Figure 1**) and written in the correct format to be evaluated by the V/L analysis computer code.

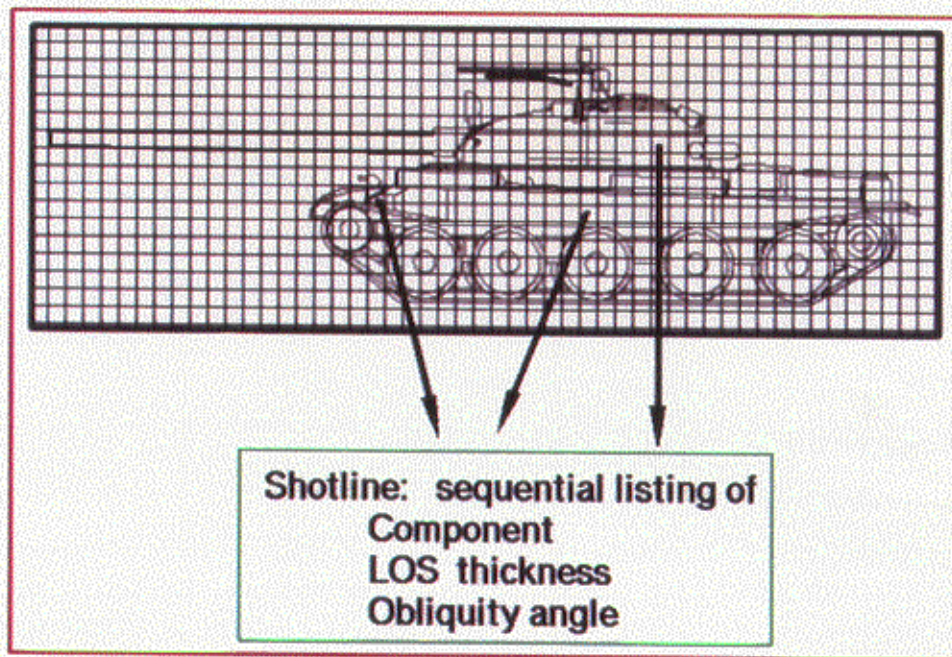

Figure 1. Manual Shotlines From Engineering Drawings.

This shotline generation procedure was unsatisfactory. The manual nature and subjectiveness made the whole process error-prone and time-consuming. In addition, only those attack views for which engineering drawings existed could be evaluated. The attempt to rectify these shortcomings led directly to the birth of 3-dimensional solid geometric modeling in the Army. The process certainly had to be computerized; hence, the solution to the shotline generation problem was twofold. First, a technique of representing the geometry of the target in the computer was required. Second, an algorithm which would allow the computer to interrogate the geometric representation stored in its memory and calculate the shotline data would complete the solution. In 1967, a contract with the **Mathematical Applications Group, Inc. (MAGI)**^[1] provided the solution. MAGI introduced the **Combinatorial Solid Geometry (CSG)** technique for representing geometry in a computer and the *ray-tracing* geometry interrogation scheme.

2.2 Combinatorial Solid Geometry

The CSG approach, still in use today, uses Boolean combinations of simple solid geometric shapes, or primitives, to model components at any level of detail. **Figure 2** is a rendering of the current set of primitives while **Figure 3** shows the results of several Boolean operations. The first geometric modeling system using the CSG technique required three separate files. The first file contained the

parameters of the individual primitives, defining the shape, size, location, and orientation of each. The second file defined the regions, which are the Boolean constructs combining the primitives from the first file. The third file identified the regions by labeling which component of the target each region represented. These CSG files constituted what has become known as a *target description*. The target description was required input to the ray-tracing code to produce the shotline information.

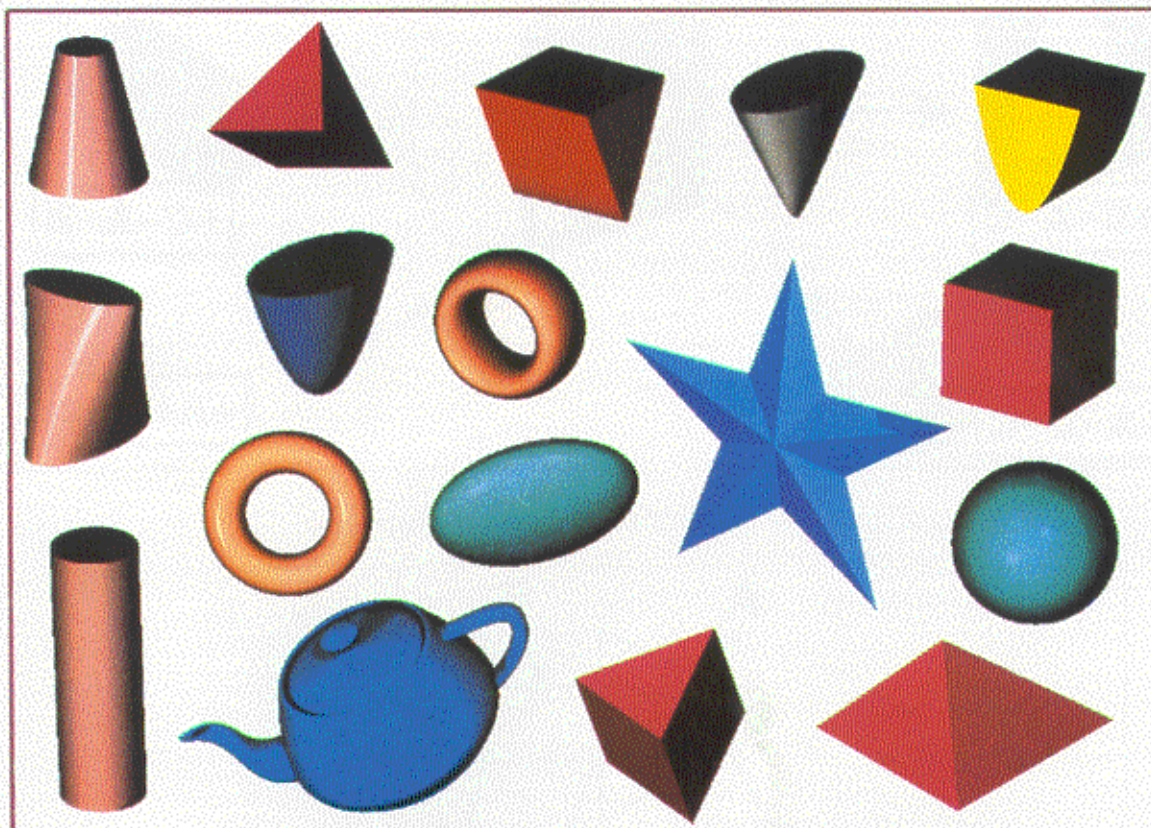

Figure 2. Sample CSG Primitives.

2.3 Ray-Tracing

The ray-tracing technique, as its name implies, mathematically intersects rays, or lines, with the CSG target description. Parallel rays are initiated from a "grid plane" oriented at the desired attack direction. These rays are intersected with the regions of the description. As the ray encounters a region, at the intersections with each of the defining primitives of that region, the 3-dimensional coordinate locations and surface normals are calculated. The primitive-ray intersections are then combined according to the Boolean formula for that region (see **Figure 4**) to produce the actual intersections for that region. These intersection coordinates are used to calculate thicknesses, which, along with surface normals and other information further identifying the region, constitute the shotline information.

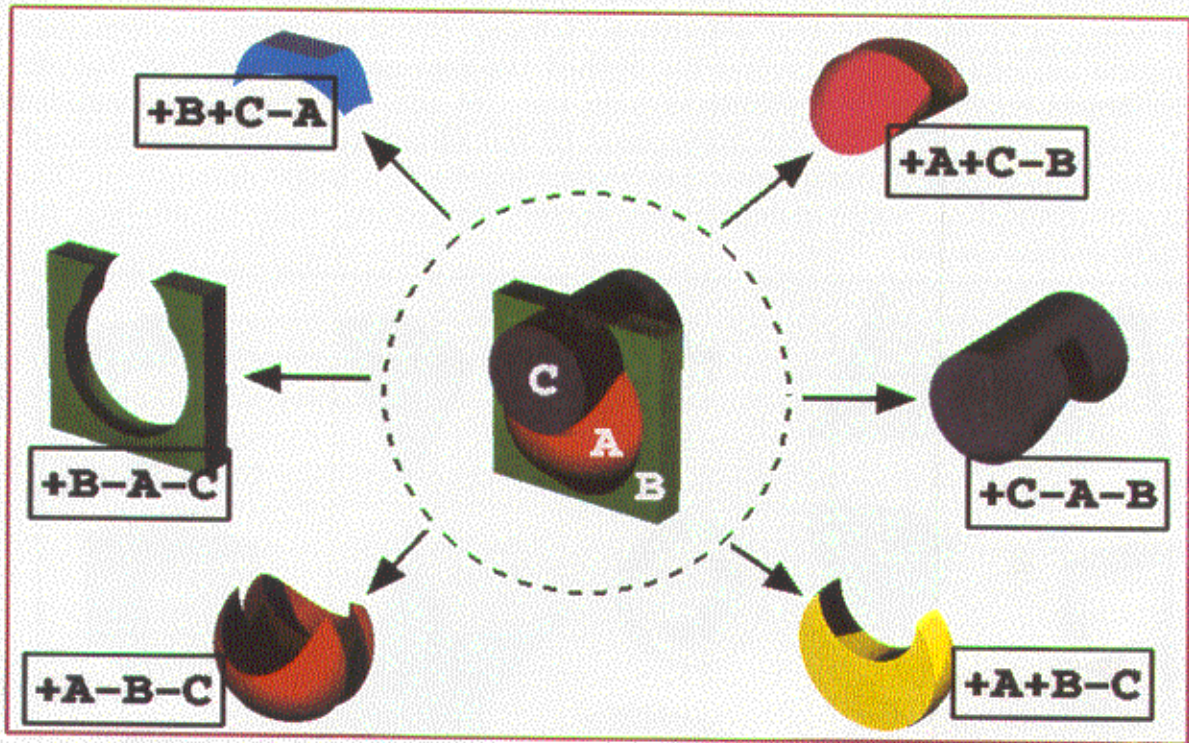

Figure 3. Examples of Boolean Operations.

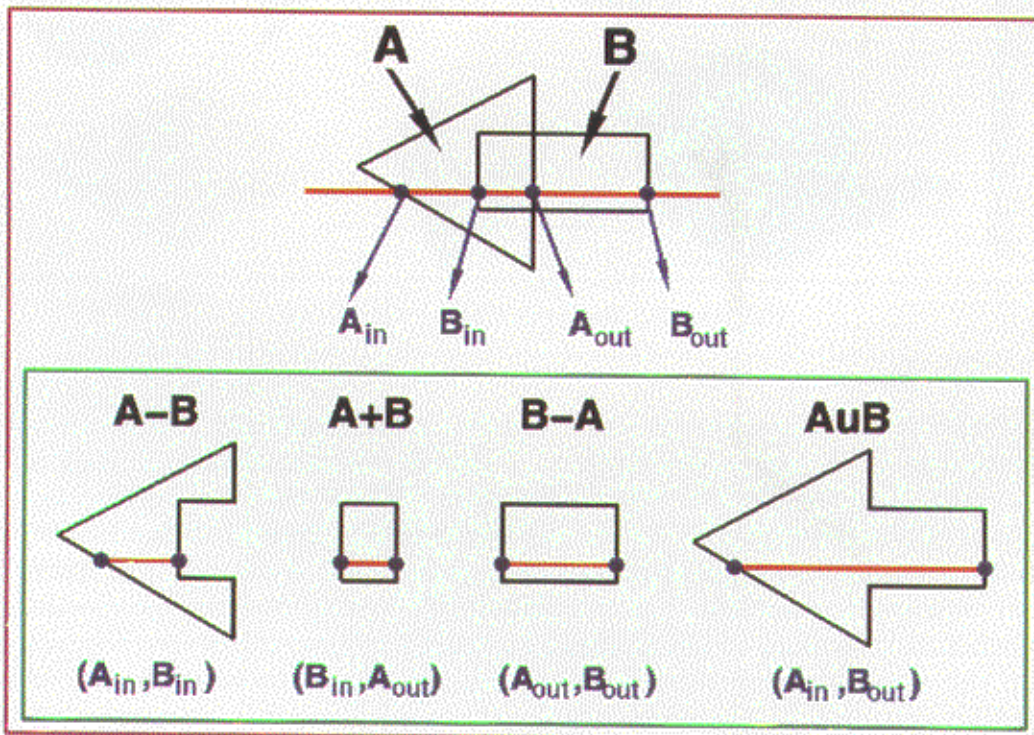

Figure 4. Ray-Tracing a Simple Region.

The ray-tracing code eliminated the shortcomings of the hand-generated shotline process and greatly increased the overall V/L capability. Parallel shotline information could now be quickly generated from any attack direction, including nonzero elevations. Furthermore, divergent rays could be used to simulate the *bursting* phenomenon. Ray-tracing continues, to this day, to be a flexible geometry interrogation tool and has been used to simulate many natural phenomena.

2.4 BRL-CAD

The development of the ray-tracing technique immediately turned the spotlight directly on the target description. In addition, new capabilities and more detailed analyses placed increased emphasis on the target descriptions. Soon the construction and validation of target descriptions became the most crucial and time-consuming element in the V/L process. The demand for highly detailed, accurate, and timely target descriptions quickly outdistanced the capability to produce them. The main reason was that the construction procedure itself remained a manual process, mired in a mainframe/batch computing environment. With the promise demonstrated by the emerging interactive computer graphics field and the move towards the open environment of the UNIX operating system, a long-term project was initiated in late 1970s to address this problem. The goal of this project was to create an interactive CSG geometric modeling system within the framework of a more flexible, portable computing environment.

In 1983, the first interactive CSG modeling system^[2] was introduced. This system greatly reduced the time required to construct and validate CSG target descriptions. The computer hardware necessary to support this interactive modeling system was rather limited, and included a mini-computer driving a single display device. Soon, however, the graphics work-station entered the market, providing a tremendous boost to the target description preparation process. The work-station provided target describers with a powerful, dedicated computing platform, including excellent interactive graphics capability, all at a relatively low cost.

About the same time, the algorithms of the early ray-tracing codes were rewritten in the C programming language and put in a library. This library made the development of new ray-tracing-based applications codes much easier. The interactive modeling system and a large volume of associated software have been bundled into what is known as the *BRL-CAD*^[3] package. This software has been distributed world-wide since 1987 and is continually being expanded and improved.

3. Analyses and Geometry Requirements

In the following sections we will examine the major types of analyses which utilize BRL-CAD geometry, presenting a brief synopsis of the capabilities, limitations, and requirements of each. Then we will discuss how these characteristics translate into demands on the geometric target description required to support

each level of analysis. The selection of analysis codes considered is not intended to be all inclusive, rather an examination of the major types of analyses most often encountered. The analysis codes will be considered in somewhat of a chronological order of development.

3.1 Nuclear Assessment

The **Vehicle Code System (VCS)**^[4] is the nuclear vulnerability assessment code and is used to evaluate the shielding properties of a vehicle against initial nuclear radiation. The VCS code uses a Monte Carlo module, **Multigroup Oak Ridge Stochastic Experiment (MORSE)**^[5] code, to estimate radiation transport through the vehicle. The VCS code calculates estimates of the radiation dosage received by individual crew members, the only critical components of the target.

Target descriptions prepared for the VCS code have traditionally been the most limited and specialized. The VCS target description requirements^[6] were first presented in detail in 1976. As significant advances have been made in computing power and memory, many of these restrictions no longer exist, but will be presented for completeness. The most restrictive condition was the limitation on the number of primitives allowed. In the late 1970s, nuclear target descriptions were limited to 600 primitives, preferably less than 300. This size restriction had several implications, the obvious being the amount of detail, which had to be used judiciously. Components with *like* attenuation characteristics had to be combined, while other components such as the hull, turret, suspension, and main armament had to be modeled in low detail. Larger components which would offer significant shielding, such as stowed ammo, also had to be represented, but as an aggregate volume.

The size restrictions of the VCS code no longer exist; however, there are some requirements that still must be considered when preparing a VCS target description. An accurate description of the armor shell is required. Armor thickness is important, but unlike ballistic models, the obliquity angles are less critical. Still, since the target description may be used for other purposes, accurate obliquity angles should be modeled. The exterior shell should include areas where radiation particles may gain entrance. This means that detail and clearances are important in areas such as hatches, sighting devices, and air intake and exhaust grills and vents. All critical components that could be affected by radiation, including the crew, should be included. Likewise, all major internal components that provide shielding, must be represented. All internal air must be modeled as a regular component. Finally, the complete target must be enclosed in an external air region, sitting on a region representing the ground.

3.2 Compartment Level

The compartment-level vulnerability methodology was the first approach to V/L assessment and, as mentioned earlier, was the driving force behind the development of geometric modeling and ray-tracing. There were two early compartment-level V/L codes, one for kinetic energy warheads and one for chemical energy (shaped charge) warheads. In 1979, these codes were combined

into the VAMP^[7] code. The compartment-level codes are the least sophisticated of the V/L codes. True to their name, these codes consider the target as a series of compartments contained within an armored shell. Penetration calculations are matched against the armor defeat criteria. Upon perforation, the residual energy (represented by a hole size) is used to predict damage from a *compartment kill curve*. The only internal components that are considered on an individual basis are those that would contribute to a catastrophic kill (K-kill) of the vehicle.

There are several important considerations when preparing a compartment-level target description. The armor shell must be described as accurately as possible since the thickness and obliquity angle are crucial in penetration calculations. Other exterior components that would affect penetration, such as the main gun, suspension components, and roadwheels, must be represented. **Figure 5** is a rendering of the exterior of a compartment-level description.

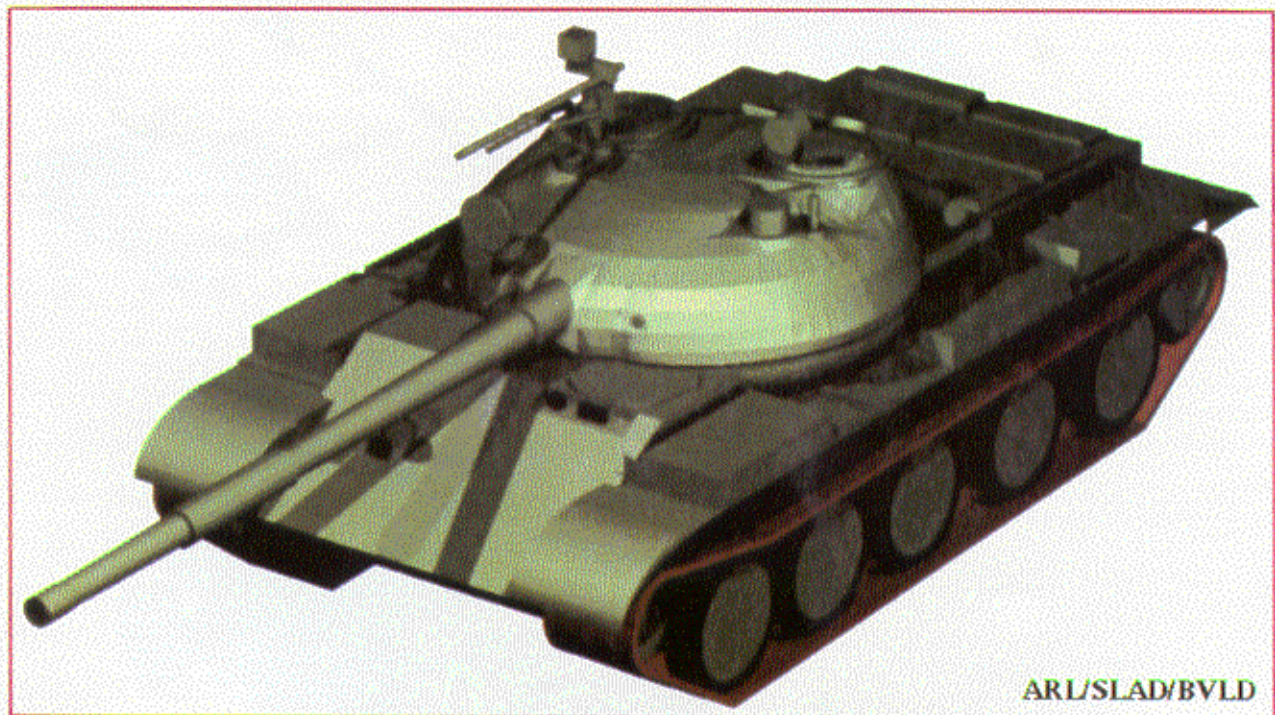

Figure 5. Exterior of a Compartment-Level Description.

The complete interior volume within the armor shell must be modeled and divided into compartments. The compartments of interest are the crew, engine, and ammo. Defining these compartments is accomplished by modeling air regions and assigning differentiating "air codes". There must not be any space between the inner surface of the armor and the air regions (compartments). There is interior space that must not be included as part of the crew, engine, or ammo compartments. These areas, such as between the hull belly and the floor and between the armor wall and an adjacent fuel tank, are modeled and identified as separate compartments. **Figure 6** shows these "compartment air regions" along with the enclosing armor shell. Any K-kill component, such as fuel tanks and

stowed ammo, must also be represented. In addition, large shielding components, such as engines and transmissions, are usually modeled at a low level of detail. Other interior components need not be modeled. Figure 7 depicts the interior detail of a compartment-level target description.

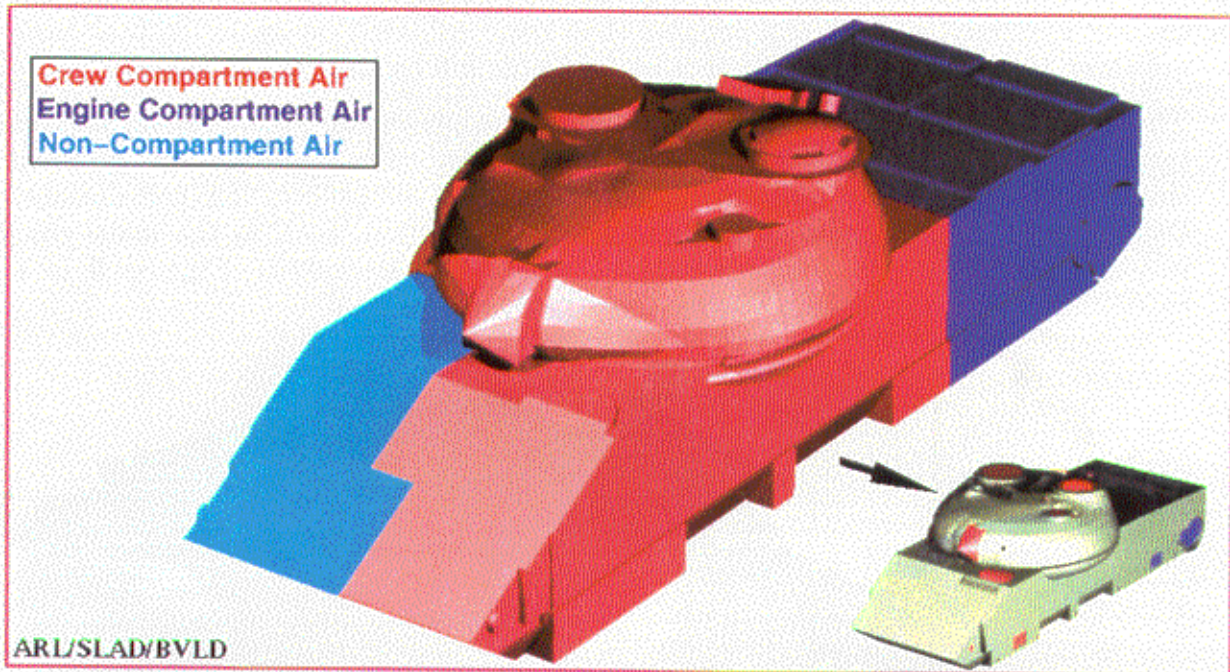

Figure 6. Air Regions Representing Internal Compartments.

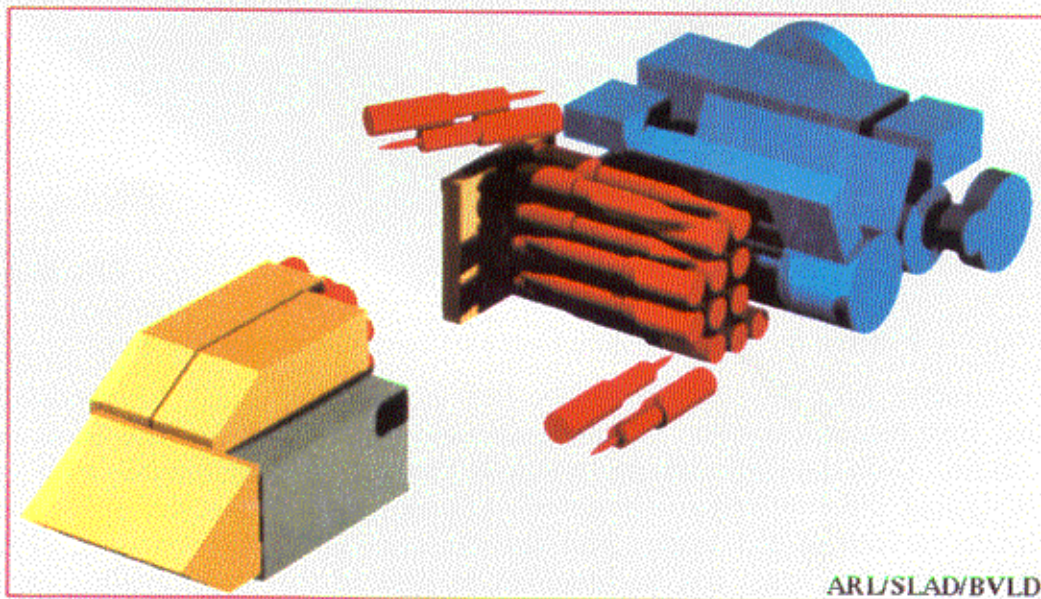

Figure 7. Interior of a Compartment-Level Description.

3.3 Component Level - Parallel Ray

The component-level vulnerability codes represent the next level of complexity in that the target is analyzed at the individual component level. The first such code was known as the VAREA^[8] code and was used for lightly armored vehicles, trucks, etc. The COVART^[9] family of codes performs similar tasks for aircraft. These codes compute the vulnerability estimates in terms of *vulnerable areas* for specific penetrators, usually fragments and small caliber direct fire weapons. This methodology requires component conditional kill probabilities given a hit for every critical component. The vulnerable area of the target from a specific view is the sum of all the individual grid-cell vulnerable areas. The grid-cell vulnerable areas are determined by calculating a cell probability of kill and multiplying it by the area of the cell. The view vulnerable area data are presented in a table for the various fragment mass and velocity combinations.

It is no surprise that the geometry requirements for the VAREA codes shifted emphasis to the individual component. The exterior shell must continue to be modeled as accurately as possible. Other exterior components must include any critical components plus any component that could contribute to a K-kill. Any exterior component should also be included if it provides any significant shielding or affects the penetration capability of the warhead. **Figure 8** shows the detail of the exterior of a component-level target description. All critical internal components must be modeled in enough detail to support a component kill analysis. The component conditional kill analysis uses presented areas of the component from several aspects, ratioing projected areas of *sensitive* regions with the total presented area. Thus, the presented area of the model of the component should accurately represent the real component. Any other noncritical internal component that provides effective ballistic shielding should also be included. At this level, components such as wiring harnesses and fuel and hydraulic lines are generally modeled. **Figure 9** is a rendering of the internal components of a component-level target description.

3.4 Component Level - Point Burst

The point burst assessment codes are simply an extension of the VAREA level codes, except the damage resulting from behind-armor debris (or spall) is explicitly estimated. Parallel shotlines are used to simulate the main penetrator while divergent shotlines (or spall rays) simulate the spall debris. The spall rays are initiated whenever a *burst point* is encountered along the path of a main penetrator. A burst point is defined whenever a main penetrator exits an armor component directly into an interior volume. The first point burst V/L code was the VAST^[10] code, which evaluated kinetic energy and shaped charge warheads versus tanks. In 1988, a stochastic point burst V/L code called SQuASH^[11] was introduced and represents a significant improvement in armored vehicle vulnerability modeling.

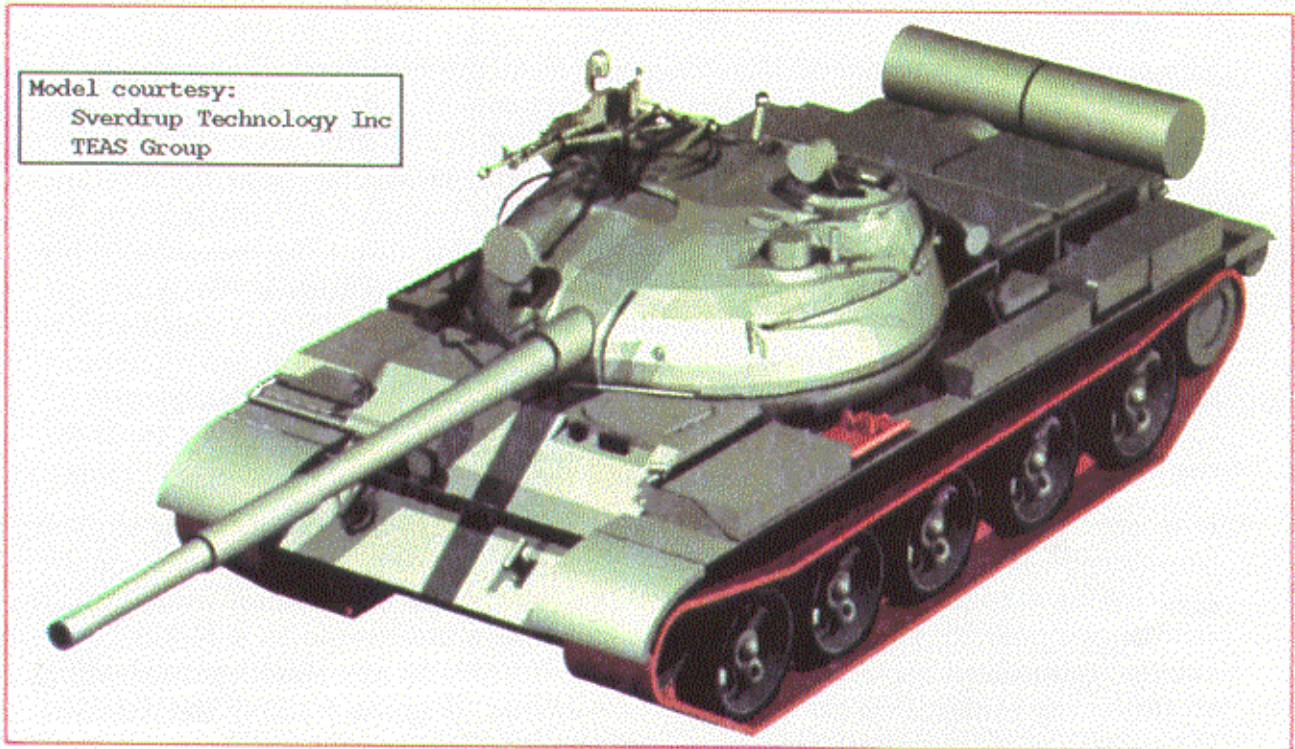
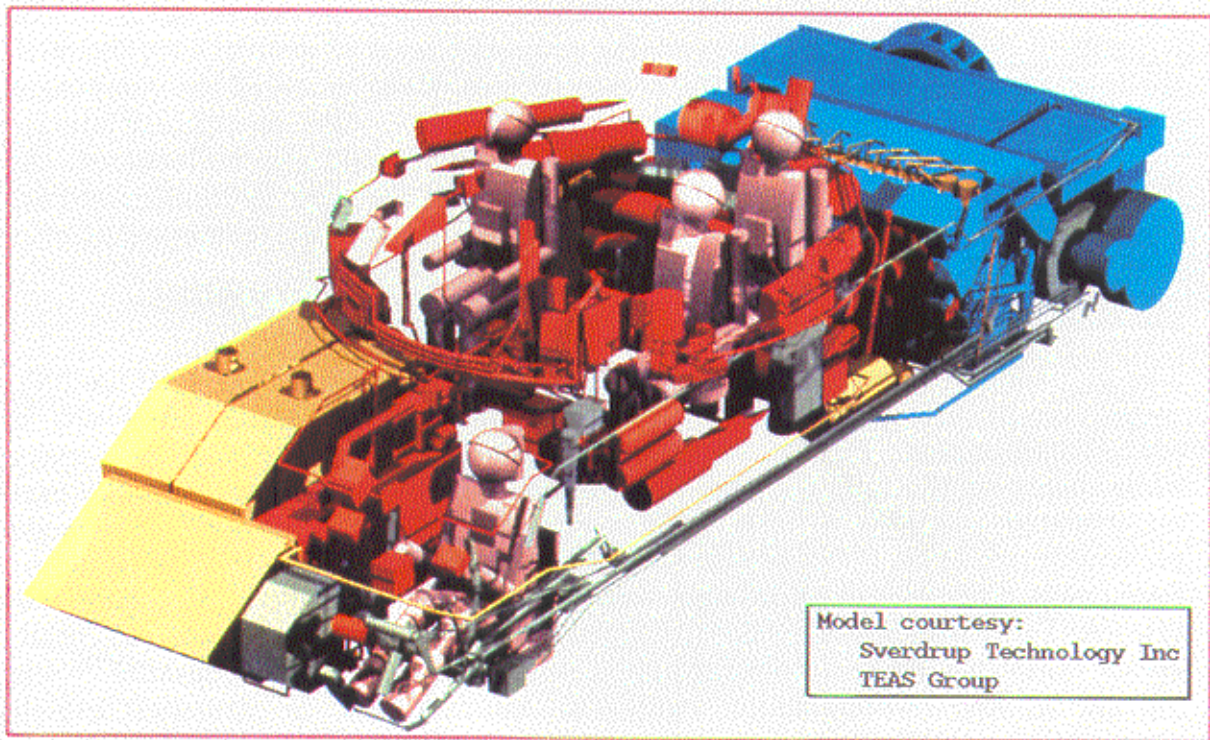

Figure 8. Exterior of a Component-Level Description.



Model courtesy:
Sverdrup Technology Inc
TEAS Group

Figure 9. Interior of a Component-Level Description.

The geometry requirements necessary to support a point burst V/L analysis are nearly identical to the VAREA requirements as far as the components are concerned. The one major difference is the need to identify burst points. Recall, burst points are located on the inner surface of armor components that are adjacent to interior volume. Hence, to locate the burst points it is necessary to know when one has entered the interior. As in the compartment analyses, this is accomplished by representing all interior volume as air regions and then identifying those where spall rays should be initiated. Note that one should avoid any "undefined" volume between the exterior shell and the air regions, or the burst points could be missed. Figures 10 through 13 are used to compare the detail of several subsystems of compartment-level and component-level target descriptions.

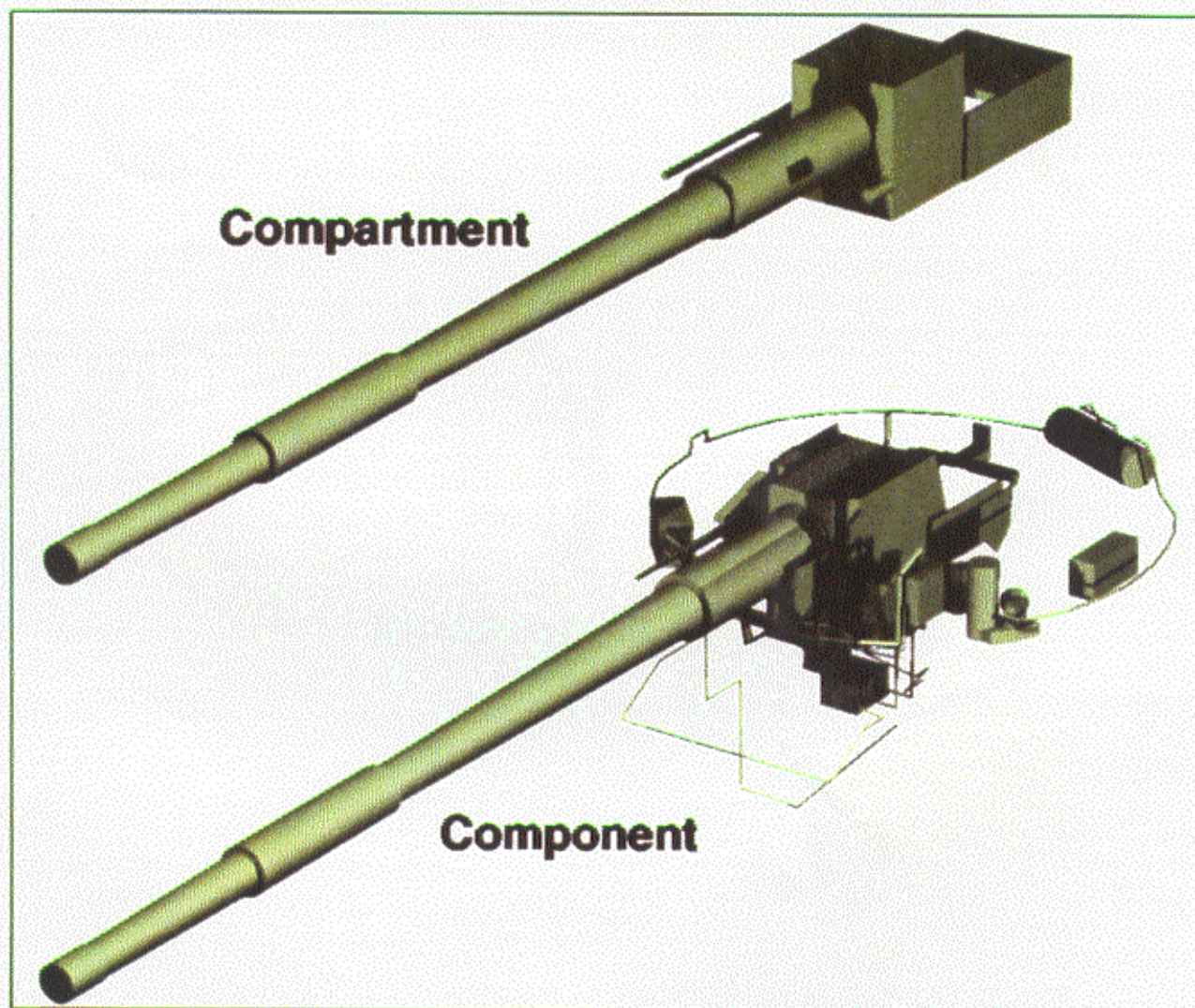

Figure 10. Compartment-Level and Component-Level Gun System.

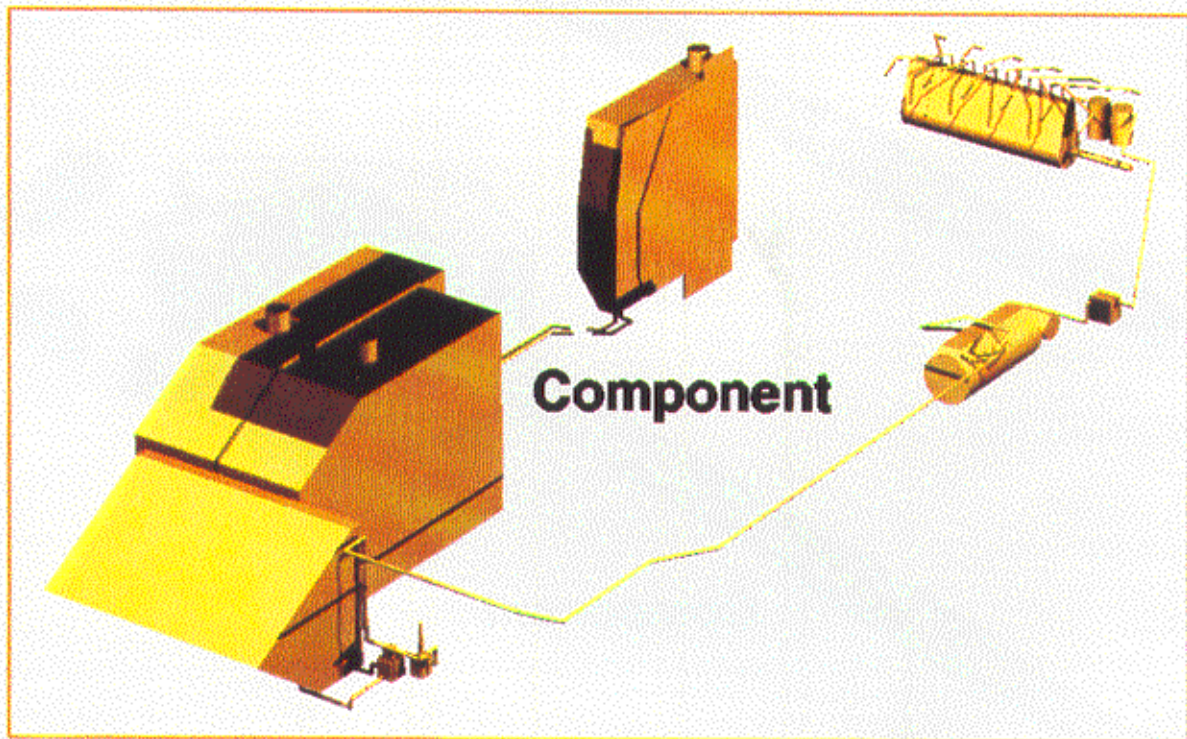
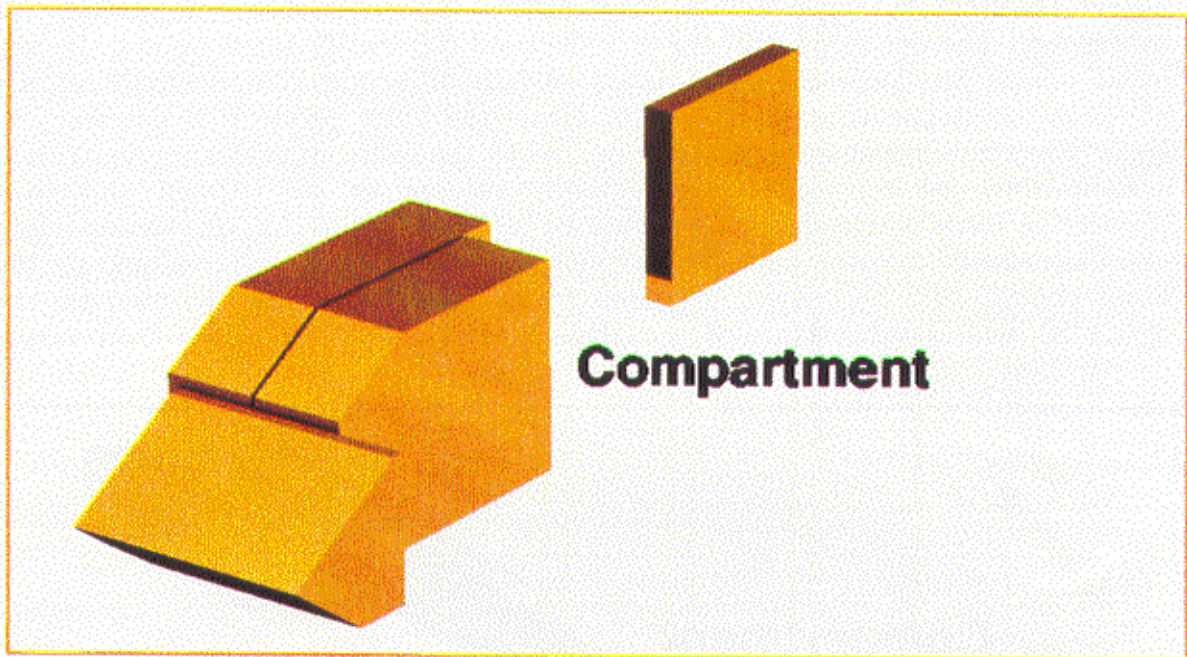

Figure 11. Compartment-Level and Component-Level Fuel System.

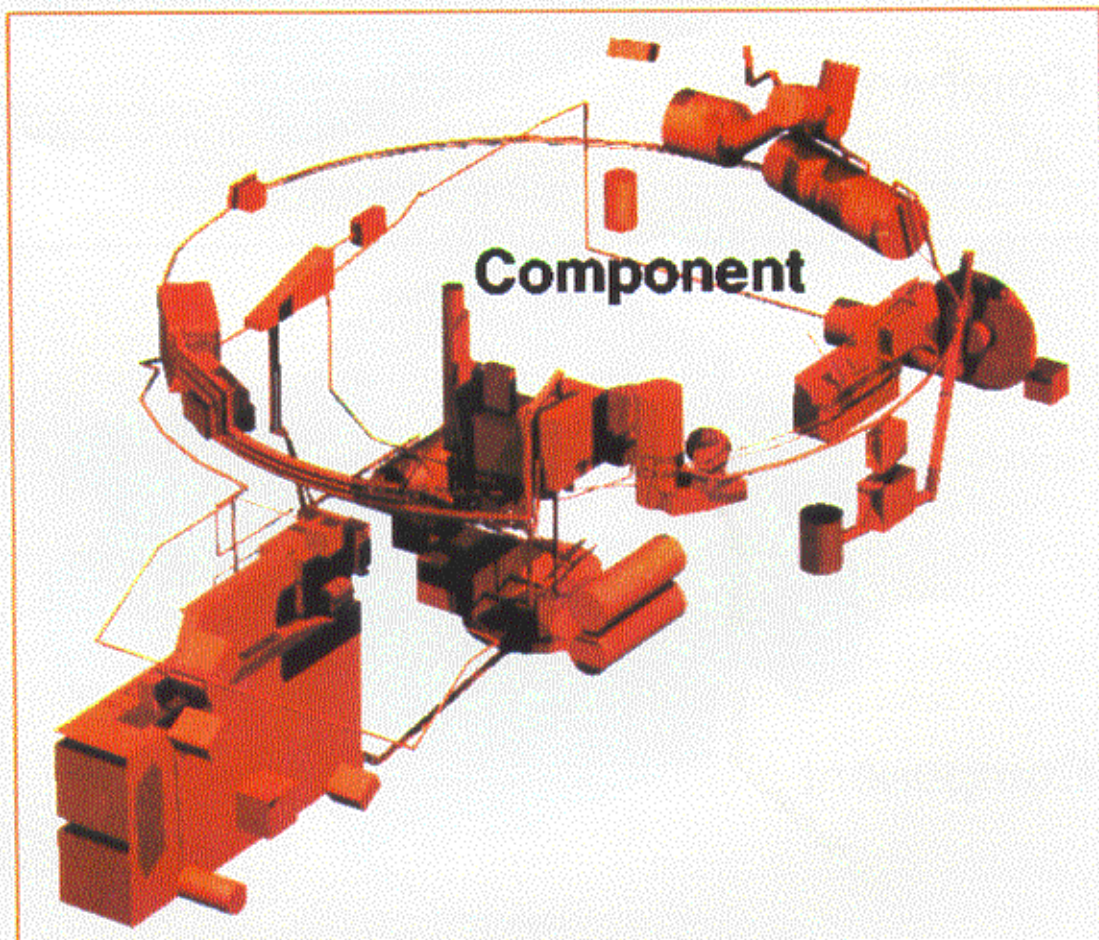
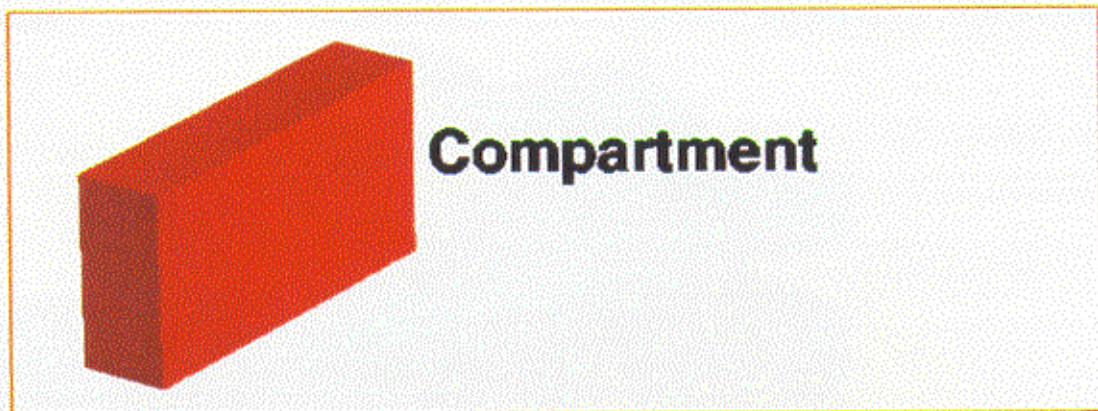

Figure 12. Compartment-Level and Component-Level Electrical System.

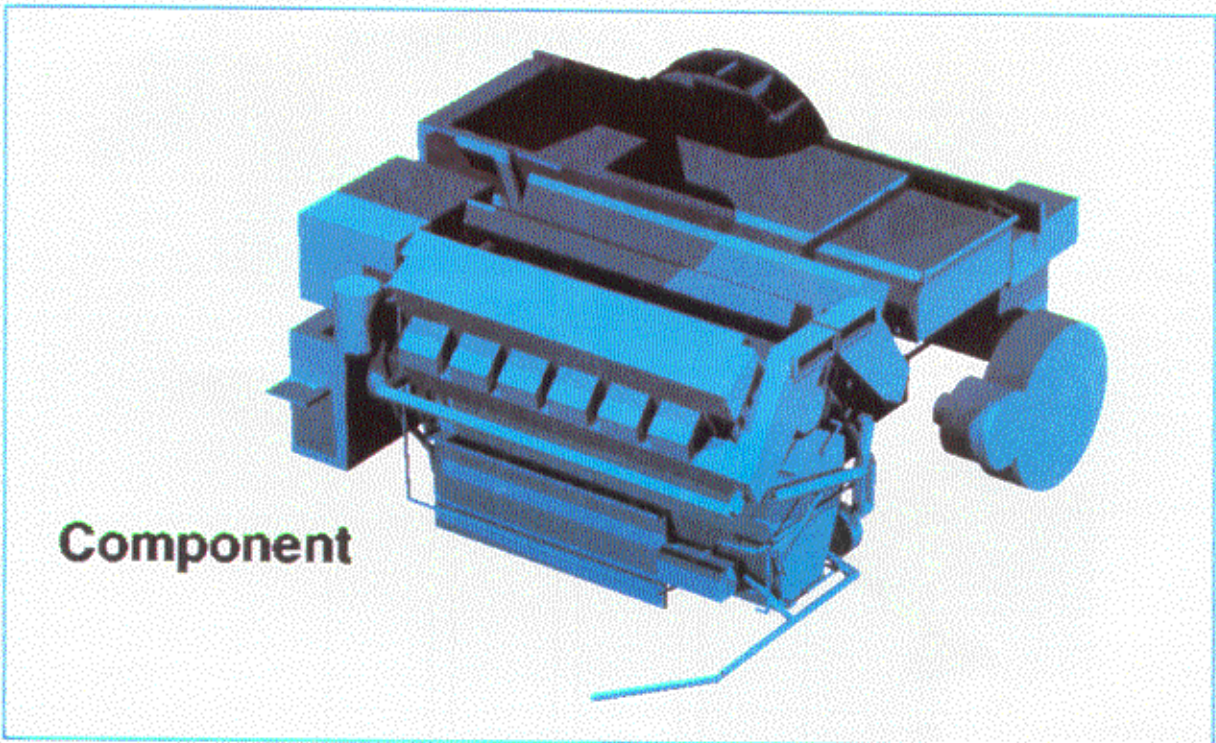
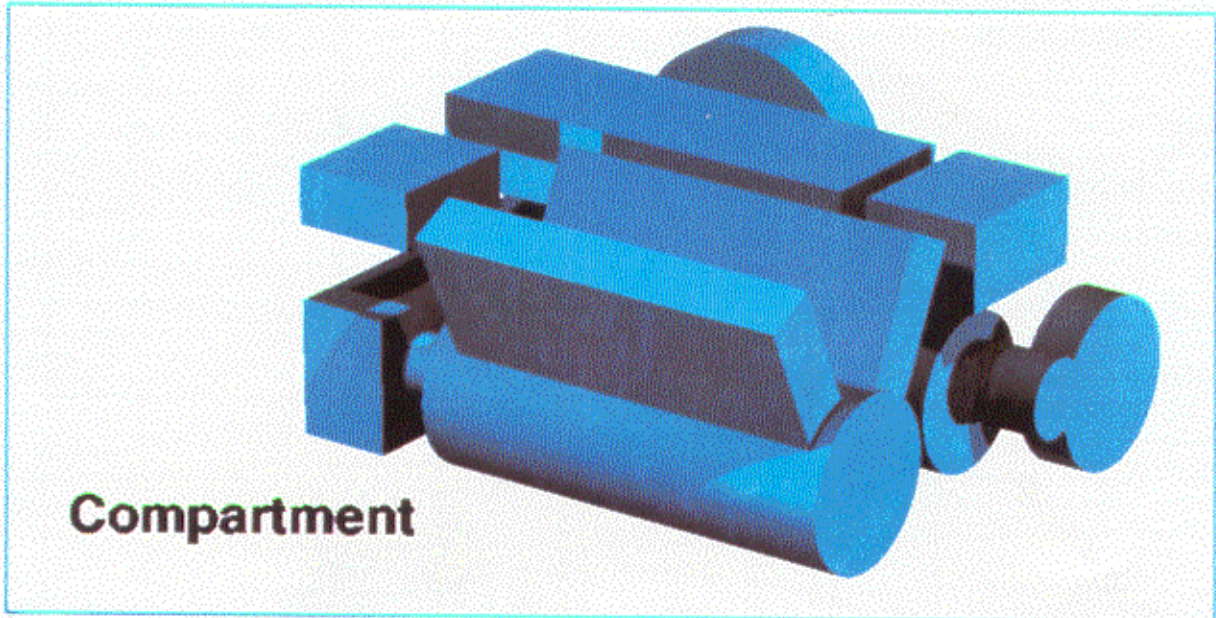

Figure 13. Compartment-Level and Component-Level Power Train.

3.5 SPARC

For many years, spare parts for military systems were stocked according to life expectancies and mean-time-between-failures in a peacetime environment. Little consideration was given to parts likely to be damaged in battle. In the early 1980s, the **SPARC** (**S**ustainability **P**redictions for **A**rmay spare component **R**equirements for **C**ombat) program was started to address this oversight. The SPARC^[12] code was developed to quantify spare parts requirements in support of combat damage repair. The SPARC methodology is really an adaptation of the point burst methodology and, therefore, accounts for damage from both the main penetrator and spall debris. The major difference was the introduction of the concept of the *mission-essential component*, a more inclusive classification than the standard V/L critical component. Any component whose loss would require repair or replacement either to prevent damage to other components or to maintain long-term operational readiness and reliability is considered mission essential.

SPARC target description requirements are basically the same as the point burst V/L analysis, except for the concept of mission-essential components. All components that would be considered critical in a point burst analysis are also considered mission essential. However, noncritical components may become mission essential if they must be replaced when damaged to maintain long-term operational status. For example, consider the third roadwheel of a tracked vehicle. This roadwheel is not considered V/L critical since the vehicle is still functional when the roadwheel is damaged. However, this damaged roadwheel could lead to problems with other suspension components such as torsion bars and the track and is, therefore, considered a mission-essential component for a SPARC analysis. All mission-essential components, even redundant components, must be uniquely identified. It is necessary, therefore, to assure that the regions used to model a component are uniquely identified, and any other occurrence of that component must be distinguished from others.

3.6 SAR Signature

This methodology predicts **S**ynthetic **A**perture **R**adar (**SAR**) images by ray-tracing the geometric model. At every intersection with the geometry, the ray is reflected in another direction according to the surface geometry and appropriate physical laws. This process is continued until the ray is reflected back to the sensor or leaves the scene.

The geometry requirements for a SAR analysis are quite different than those discussed up to this point. If the target exterior is completely conducting (i.e., metal), then no internal components are required. However, if portions of the exterior shell (or any exterior component) are comprised of nonconducting material (e.g., glass, plastic, etc.), then appropriate internal components should be modeled. Likewise, hubs and rims should be modeled in detail as rubber is also transparent to radar. Generally though, all the detail is concentrated on the exterior surface. Since surface normals and curvature information are required,

the exterior shell must be as accurate as possible. Curved surfaces must be modeled as such and as faithfully as possible. Thicknesses are unimportant, but if known should be modeled accurately. All exterior accessories should be modeled and in great detail. Components such as headlights, taillights, hinges, handles, braces, supports, large bolt heads, and individual track links should be included in the model. Even rounded corners should be considered for larger components such as external fuel tanks. This detail is required since any condition that might possibly give a SAR return (e.g., a small corner reflector) should be geometrically modeled. Figures 14 and 15 are exterior views of a SAR-level target description with several areas of detail highlighted.

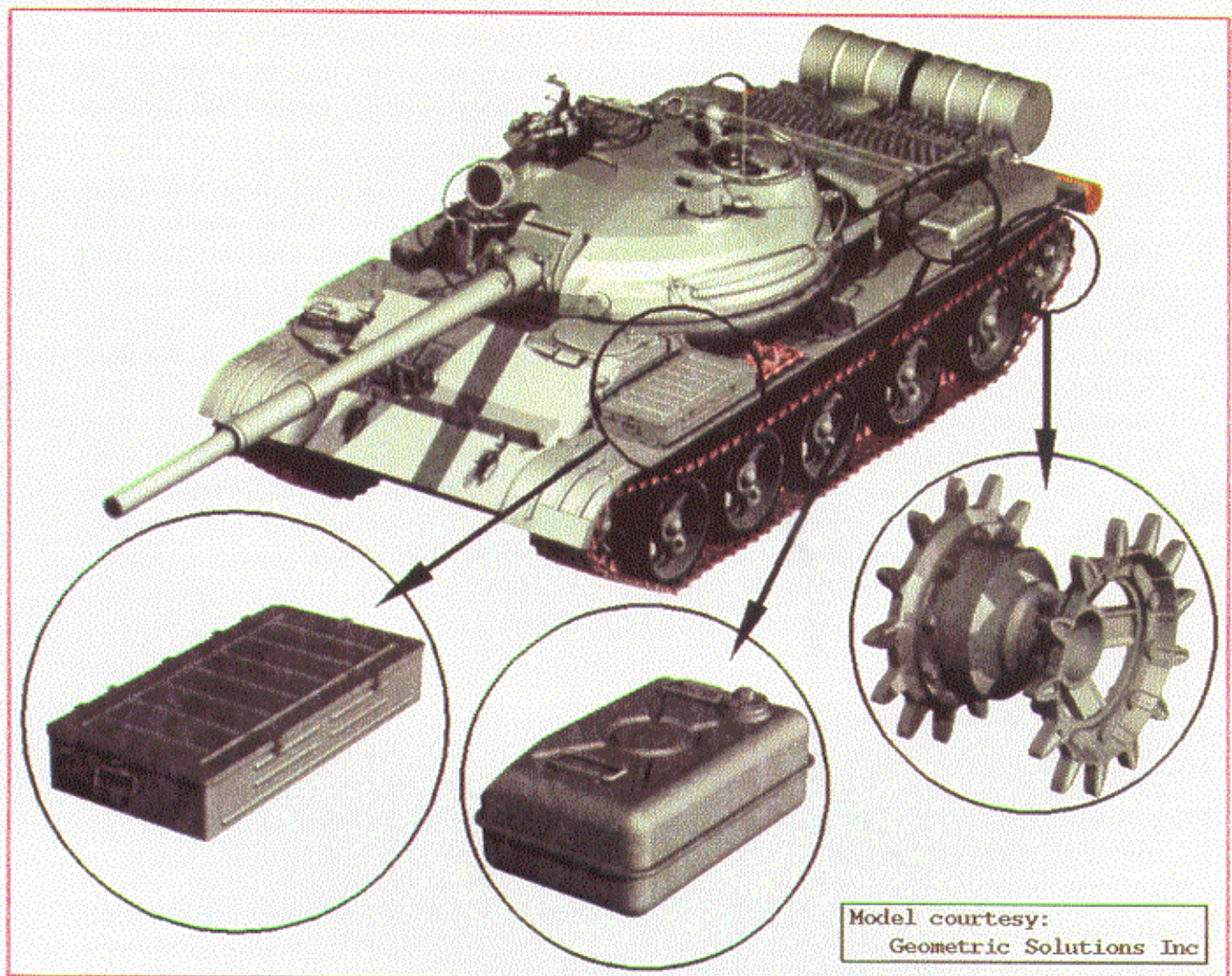

Figure 14. Example of a SAR-Level Target Description.

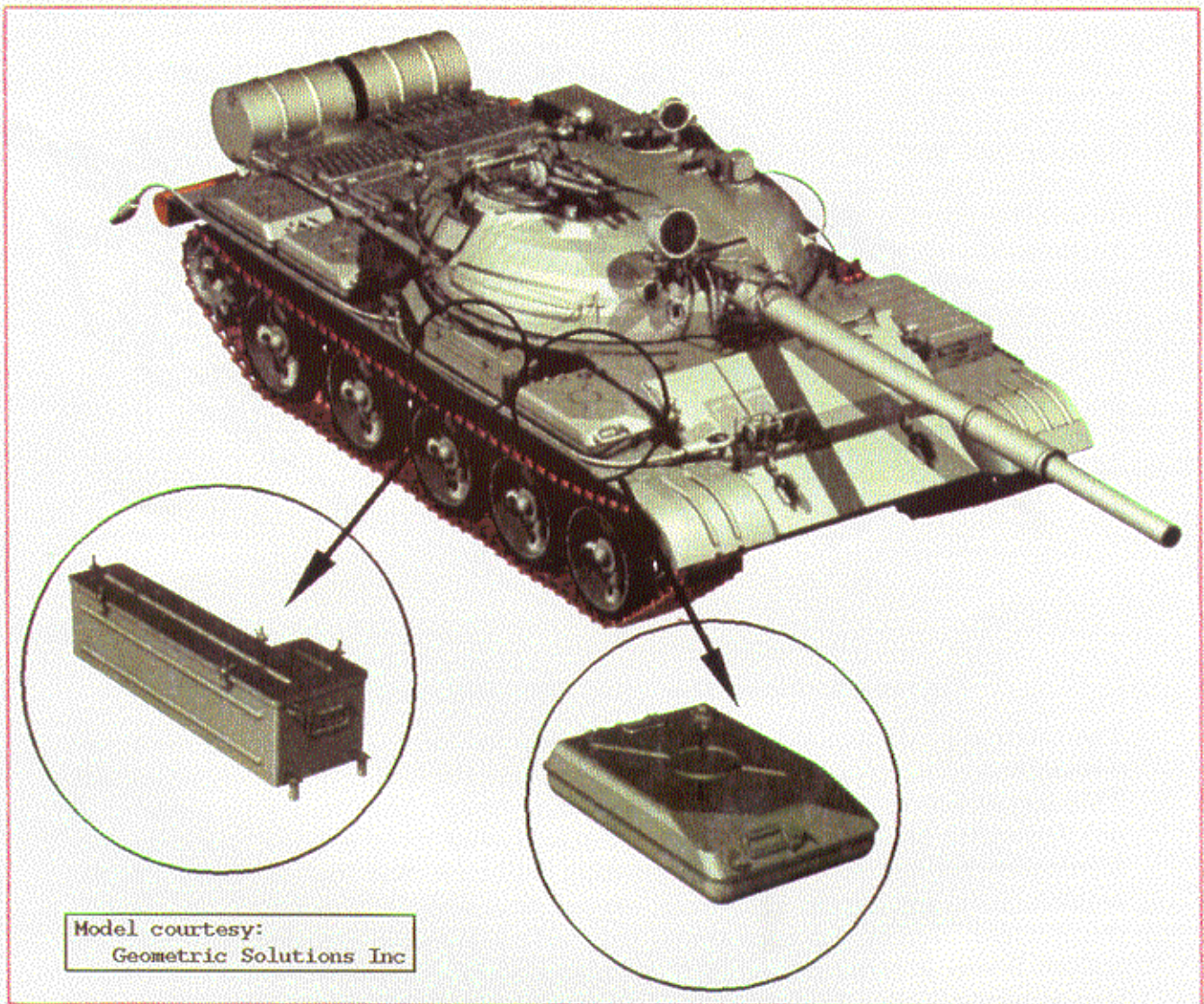

Figure 15. Example of a SAR-Level Target Description.

3.7 IR Signature

The InfraRed (IR) methodology is designed to predict surface temperatures of targets. The Physically Reasonable Infrared Signature Model (PRISM)^[13] code is one of several such codes in use today. The PRISM code is a lumped parameter finite difference model which requires that geometric regions be represented as nodes. Thus, conversion processes are required to prepare a CSG model for input to this thermal model. The conversion process uses the geometry to create the nodal inputs (see Figure 16). Afterwards, the geometry is again referenced to display the resulting thermal predictions. The Faceted Region EDitor (FRED)^[14] and the IRPREP^[15] are two such codes designed to convert BRL-CAD geometric models for input to the PRISM code.

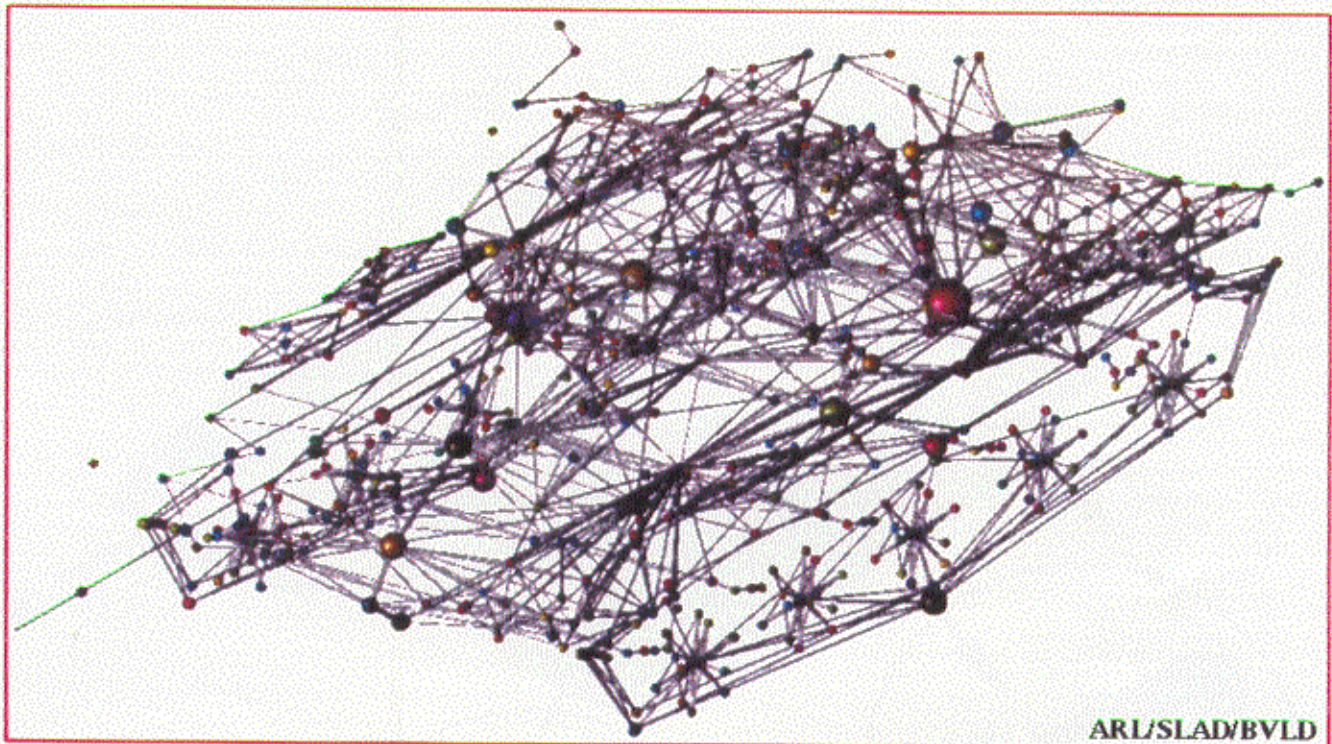

Figure 16. Nodes Converted From BRL-CAD Geometry.

The thermal prediction models do place several unique requirements on the target description. The heat flow analysis requires that the CSG regions be isothermal. This means portions of the exterior shell of a vehicle, that would be modeled as one region for ballistic V/L analyses, may now need to be divided into a number of smaller regions to reduce temperature variance over the regions. PRISM requires that any region have only one surface normal. To accommodate this requirement, during the conversion, the surface normals are averaged over the region; hence, a large region with numerous surface normals should be divided into smaller regions. For example, if the turret of a tank is modeled as one large region, there will be only one surface normal associated with the whole turret (see **Figure 17**). As in the compartment and point burst V/L descriptions, the internal volume must be modeled as air regions. The only interior components required are those comprising the engine and air intake and exhaust ducts. All these requirements are further explained in the IRPREP reference.

4. Managing BRL-CAD Data Files

In the following sections, we will discuss the BRL-CAD data file and suggest an approach to managing it. The data file is designed to allow storage of huge volumes of information. In the 1970s, target descriptions consisting of 1,000 objects were considered high detail, yet today there are descriptions consisting of tens of thousands of objects. Individual components have been treated as a

system themselves and modeled down to the "wire" level (see **Figure 18**). Descriptions of dozens of separate targets have been combined in one file to represent whole military units (see **Figure 19**). All of these feats owe their success to the design and flexibility of the BRL-CAD database. We will look at how the data are stored, the internal file structure, and how data are referenced and organized.

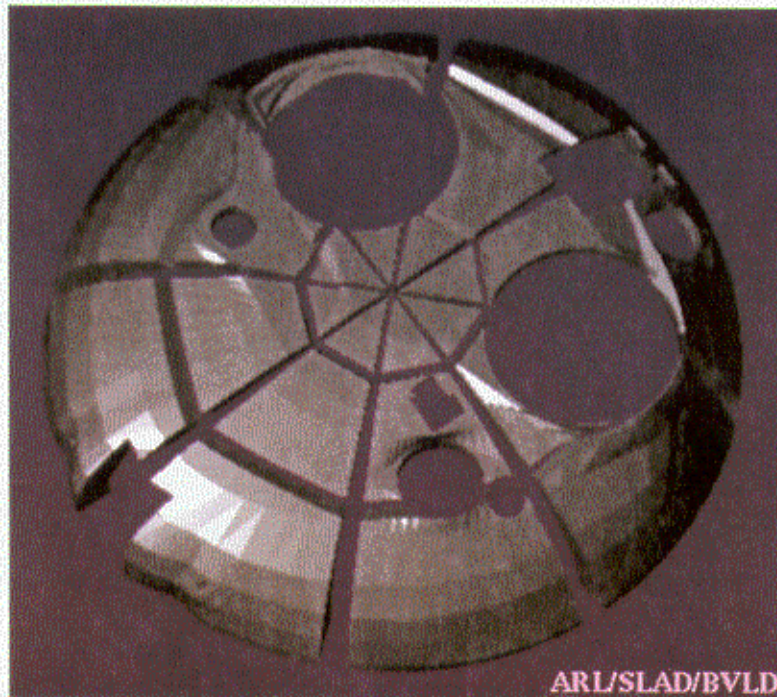

Figure 17. Sliced Turret to Produce Different Normals.

4.1 Data File Structure

The BRL-CAD data file is a binary UNIX file of sequential blocks or records of data. The actual organization of the data in any particular record depends on the type of information stored there. There are only two main types of records, the *solid* record and the *combination* record. The solid record stores all the parameters necessary to define the various primitives. The combination record is used to store all the other nonsolid objects. Its obvious function is to group any number of objects together. The combination record consists of a *header* record followed immediately by a series of *member* records. It is important to note that each member record in a combination contains a transformation matrix. Any editing is stored in these matrices. If the whole combination is edited, then every member matrix is modified to reflect this editing. Any member of a combination may be edited as part of that combination. In this case, only the appropriate member matrix is modified. The important fact to remember is that any editing of combinations is stored in transformation matrices. On the other hand, any editing of solids results in actual changes in the stored parameters.



Figure 18. High Detailed Individual Component Modeling.

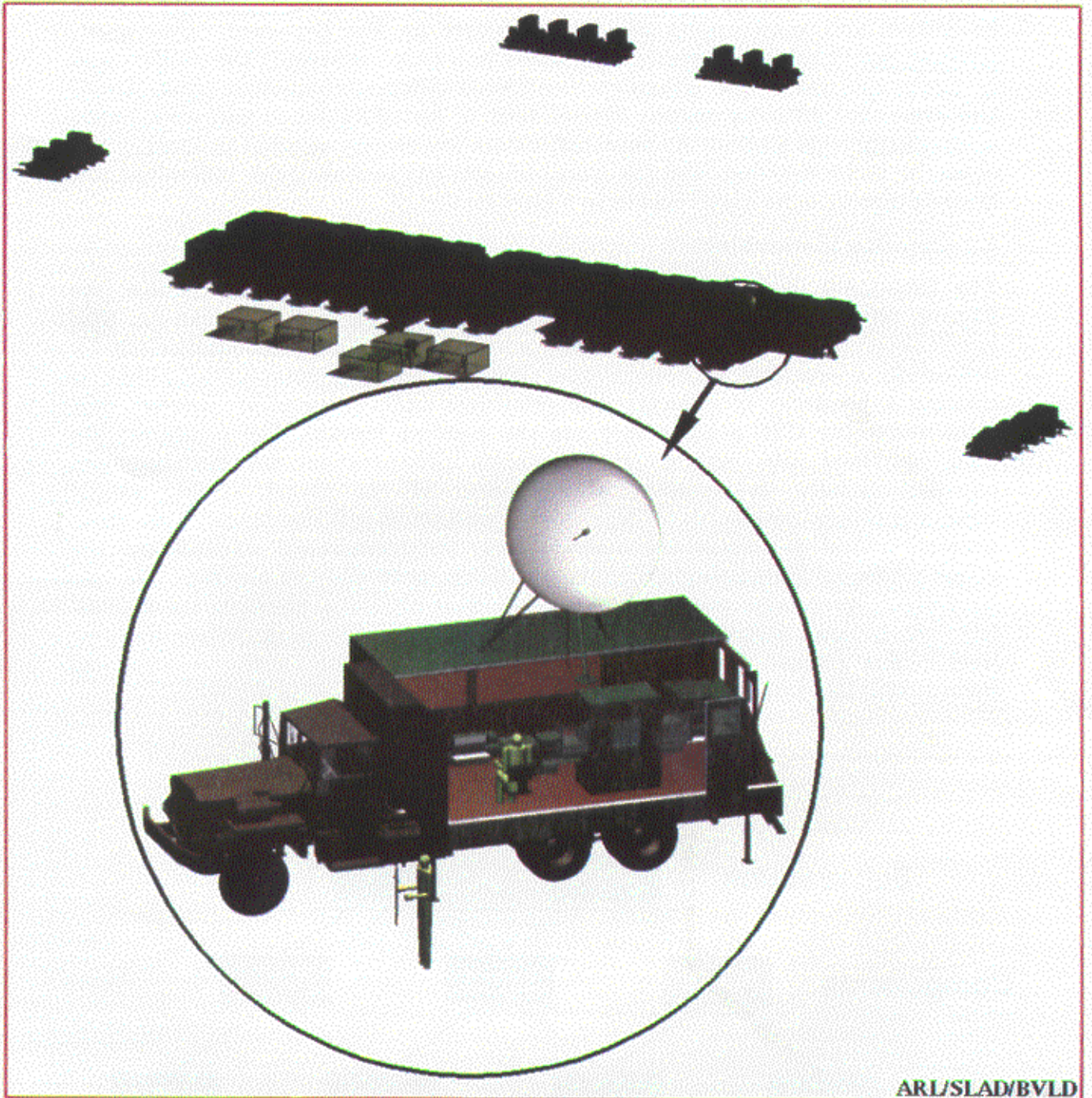

Figure 19. Model of a Corps Command Post.

All objects in the BRL-CAD data file are referenced by a name. This name must be unique and may consist of any characters on the keyboard. One must, however, avoid using any special characters in a name, especially the /, \, *, and !. Upper and lower case letters are considered different characters; thus, *Armor* and *armor* are different names. Names such as *plate#23(t=2.5)* and *wire_1w235* are perfectly legal names. As expected, names are usually selected to identify the object as to its function, and the whole process has become quite individualized. We will discuss more about names in a later section.

4.2 Creating Hierarchies

The BRL-CAD data file is naturally organized in a hierarchical nature (see **Figure 20**). From the discussion earlier about data records, one can see that every object in the data file is either a member of some combination or by definition, a top-level object. Hence, just by creating combinations, one is creating a hierarchy of objects. The primitives (solid records) are created first since under the CSG scheme they are the building blocks. The primitives are then combined into regions (combinations). The regions are next grouped together, usually to represent a component of the target. Next, several components are combined to represent a subsystem of the target. As these natural, logical groupings are accomplished, the hierarchical structure of the target emerges. This grouping process continues until one combination, *the top-level object*, represents the complete target. This hierarchy has been constructed from the bottom, where all the solids were defined, to the peak, where the top-level object reigns. This hierarchy is *evaluated* opposite of the way it was constructed, i.e., from the top, down.

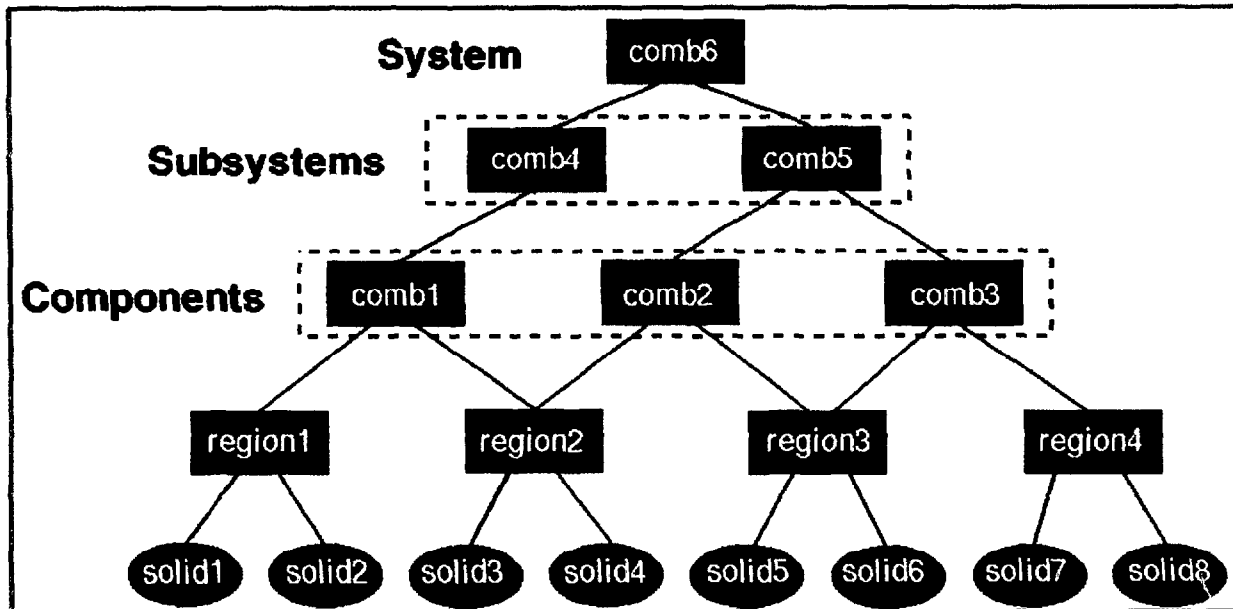

Figure 20. The BRL-CAD Hierarchical Data Structure.

4.3 Some Conventions

As the modeling of a target progresses and the hierarchical structure takes shape, the user has the freedom to select names on a personal preference basis. However, it is beneficial to other users of the data if some conventions or standard practices are observed in the selection of the names. The following scheme is presently in use at the BVL D for the construction of BRL-CAD models of armored vehicles. This scheme can be used as a guide in selecting similar naming conventions for other classes of targets. The naming conventions for armored vehicles are concerned only with the top few levels of the hierarchy. The modeler is free to be creative at the lower levels.

As previously discussed in detail, BRL-CAD target descriptions are utilized in several V/L applications. It is only logical, therefore, that the top-level name[s] should indicate the intended usage. Upon seeing the top-level object name, any user would then know the intended application and, therefore, how the target was modeled. Note that the "tops" command in MGED (the BRL-CAD geometry editing code) will list all top-level objects in a BRL-CAD file. As we have seen, components are modeled differently depending on the intended application, and this difference is often in the amount of detail. The hierarchical nature of the data file allows one to create several versions of a single component while sharing common geometry. Extending this feature allows several versions of the same target to coexist in the database, sharing common elements. With this in mind, each top-level name has two characters assigned which are used to distinguish lower-level names. In the armored vehicle naming scheme, the following top-level names have been selected (the assigned two characters are in parentheses): *nuclear (nu)*, *compartment (ca)*, *component (co)*, *sparc (sp)*, *radar (ra)*, and *infrared (ir)*. As new applications arise, a similar top-level name and associated two-character designator will be chosen.

At the next level immediately below the top level, which we will call the (-1) level, we have selected three names: *turret.nn*, *hull.nn*, and *suspension.nn*. The "nn" suffixes represent the two characters assigned to the top-level names. At the next level below each of these names, the (-2) level, we have selected three names for the *hull.nn* and *turret.nn* groups. No further names have been selected for the *suspension.nn* group. For the *turret.nn* group, the following names have been selected: *tur.ext.nn*, *tur.int.nn*, and *tur.air.nn*. As no surprise, the following names have been selected for the *hull.nn* group: *hull.ext.nn*, *hull.int.nn*, and *hull.air.nn*. These lower-level naming conventions for armored vehicles are summarized in **Table 1**.

TABLE 1. Lower-Level Naming Conventions for Armored Vehicles.

Names	
(-1) Level	(-2) Level
turret.nn	tur.ext.nn tur.int.nn tur.air.nn
hull.nn	hull.ext.nn hull.int.nn hull.air.nn
suspension.nn	-none-

5. Modeling Philosophy

Probably one of the difficult parts of geometric modeling is where and how to begin the process. As with most procedures, the first step should consist of a review, analysis, and planning phase. Hopefully, some of what has been presented up to this point will help in this initial phase. The modeler should think about the task that lies ahead, considering such things as the following: just exactly what is the final expected product; what will the model be used for; how much descriptive information is available, and what form is it in; what, if anything, has been done in the past; and can existing ("library") components be used. Next, one should devise a general plan on how to accomplish the actual construction of the model, including rough time estimates for each phase. This general plan should include all the major subsystems of the target that must be modeled. For most military targets, the tersest general plan would consist of the following: (1) model the exterior shell, (2) model the internal air, and (3) model all the remaining components. Of course we are being facetious about step (3), but steps (1) and (2) of this general plan are genuine. The goal is to get a "correct" exterior shell (with internal air if necessary) before any ~~components~~ components are added. If a tank were being modeled, the first steps might become as follows: model the hull shell, model the hull air, model the turret shell, and model the turret air.

Finally, since much of the modeling effort goes into step (3) (model all remaining components), we will discuss how to model components. This discussion will be more "cookbook" oriented, but we still will not go into the details. Other publications^[16] have discussed geometric modeling with BRL-CAD in detail. As always, initially, time should be spent analyzing and planning. First analyze the component to be modeled and decide on the detail required, formulating exactly how to represent the component, including what solids to use and how to combine them into regions. Then create the solids, so they have the desired shape, size, and orientation. To take advantage of any symmetry, create the solids at the origin. Next combine the solids into the regions, then group these regions into a combination representing the completed component. At this point check for and

fix any interferences (regions occupying the same volume) within the component and create pictures for visual verification. Note that both of these actions are performed using ray-tracing. The model of the component is now completed, so it's time to move it to its location within the target. This task is accomplished by editing the combination (translate, scale, and/or rotate). Recall, this editing is stored in the matrices of the member records, so the components primitives (solid records) are still at the origin. It is recommended to "push" (an MGED command) this editing down to the solid records at this time. Next check for and fix any interferences between this component at its new location and the rest of the description. This process is repeated for every component that is to be modeled.

6. Summary

In this paper we have presented a general, overview type of approach to geometric modeling with BRL-CAD. We outlined the important link between the intended application and the overall requirements of the geometric model. We looked at an approach to effective BRL-CAD database management, based on the design of the database structure itself. We also presented some standard naming conventions that have proven effective for armored systems. Finally, we discussed the philosophy of geometric modeling and presented a general plan to accomplish any modeling project.



Intentionally Left Blank

7. References

1. Mathematical Applications Group, Inc. "A Geometric Description Technique Suitable for Computer Analysis of Both Nuclear and Conventional Vulnerability of Armored Military Vehicles." MAGI-6701, AD847576, August 1967.
2. Muuss, Michael, Keith Applin, Robert Suckling, Gary Moss, Earl Weaver, and Charles Stanley. "GED: An Interactive Solid Modeling System For Vulnerability Assessments." BRL-TR-02480, U.S. Army Ballistic Research Laboratory, Aberdeen Proving Ground, MD, March 1983.
3. Muuss, Michael (compiler). "Ballistic Research Laboratory CAD Package, A Solid Modeling System and Ray-Tracing Benchmark Distribution Package." Release 1.2, June 1987, Release 3.0, October 1988, and Release 4.0, U.S. Army Ballistic Research Laboratory, Aberdeen Proving Ground, MD, October 1991.
4. Rhoades, W. A. "Development of a Code System for Determining Radiation Protection of Armored Vehicles (The VCS Code)." ORNL-TM-4664, Oak Ridge National Laboratory, Oak Ridge, TN, October 1974.
5. Emmett, M. B. "The MORSE Monte Carlo Radiation Transport Code System." ORNL-TM-4972, Oak Ridge National Laboratory, Oak Ridge, TN, February 1975.
6. Schmoke, M., K. Applin, and W. Olson. "Computer Target Simulations Of The US M60A1 Tank For Use In Nuclear Vulnerability Analyses." Report No. 1943, U.S. Army Ballistic Research Laboratory, Aberdeen Proving Ground, MD, November 1976.
7. Nail, C. L., T. E. Beardon, and E. Jackson. "Vulnerability Analysis Methodology Program (VAMP) - A Combined Compartment-Kill Vulnerability Model." CSC TR-79-5585, Computer Sciences Corporation, Madison, AL, October 1979.
8. Joint Technical Coordinating Group for Munitions Effectiveness. "VAREA Computer Program, Volume I - User Manual." 61JTTCG/ME-71-6-1, Volume II - Analyst Manual, 61JTTCG/ME-71-6-2, February 1971.
9. Joint Technical Coordinating Group for Munitions Effectiveness. "COVART II - A Simulation Program for Computation of Vulnerable Areas and Repair Times, User Manual." 61JTTCG/ME-84-3, September 1985.
10. Nail, C. L. "Vulnerability Analysis For Surface Targets (VAST) - An Internal Point-Burst Vulnerability Assessment Model - Revision I." CSC TR-82-5740, Computer Sciences Corporation, Madison, AL, August 1982.
11. Deitz, Paul H., and Aivars Ozolins. "Computer Simulations of the Abrams Live-Fire Field Testing." Proceedings of the XXVII Annual Meeting of the Army Operations Research Symposium, 12-13 October, 1988, Ft. Lee, VA;

also BRL-MR-3755, U.S. Army Ballistic Research Laboratory, Aberdeen Proving Ground, MD, May 1989.

12. Saccenti, John C., and Robert N. Schumacher. "SPARC Analysts' Methodology Handbook." BRL-TR-02562, U.S. Army Ballistic Research Laboratory, Aberdeen Proving Ground, MD, April 1984.
13. Reynolds, William R. "PRISM User's Manual, Version 2.0." Keweenaw Research Center, Michigan Technological University, Houghton, MI, October 1989; PRISM 3.0 User's Manual, Houghton, MI, July 1991.
14. Buxton, E. T., D. R. Petzko, and J. Jones. "FRED User's Manual, Faceted Region EDitor." U.S. Army Tank-Automotive Command and OptiMetrics, Inc., Warren, MI, December 1989.
15. Coates, Susan A., and Edwin O. Davisson. "User's Manual For IRPREP." BRL-SP-96, U.S. Army Ballistic Research Laboratory, Aberdeen Proving Ground, MD, September 1992.
16. Ellis, Carol A. "Vulnerability Analyst's Guide to Geometric Target Description." BRL-MR-4001, U.S. Army Ballistic Research Laboratory, Aberdeen Proving Ground, MD, September 1992.

<u>No. of</u> <u>Copies</u>	<u>Organization</u>	<u>No. of</u> <u>Copies</u>	<u>Organization</u>
2	Administrator Defense Technical Info Center ATTN: DTIC-DDA Cameron Station Alexandria, VA 22304-6145	1	Commander U.S. Army Missile Command ATTN: AMSMI-RD-CS-R (DOC) Redstone Arsenal, AL 35898-5010
1	Commander U.S. Army Materiel Command ATTN: AMCAM 5001 Eisenhower Ave. Alexandria, VA 22333-0001	1	Commander U.S. Army Tank-Automotive Command ATTN: AMSTA-JSK (Armor Eng. Br.) Warren, MI 48397-5000
1	Director U.S. Army Research Laboratory ATTN: AMSRL-OP-CI-AD, Tech Publishing 2800 Powder Mill Rd. Adelphi, MD 20783-1145	1	Director U.S. Army TRADOC Analysis Command ATTN: ATRC-WSR White Sands Missile Range, NM 88002-5502
1	Director U.S. Army Research Laboratory ATTN: AMSRL-OP-CI-AD, Records Management 2800 Powder Mill Rd. Adelphi, MD 20783-1145	(Class. only) 1	Commandant U.S. Army Infantry School ATTN: ATSH-CD (Security Mgr.) Fort Benning, GA 31905-5660
2	Commander U.S. Army Armament Research, Development, and Engineering Center ATTN: SMCAR-IMI-I Picatinny Arsenal, NJ 07806-5000	(Unclass. only) 1	Commandant U.S. Army Infantry School ATTN: ATSH-WCB-O Fort Benning, GA 31905-5000
2	Commander U.S. Army Armament Research, Development, and Engineering Center ATTN: SMCAR-TDC Picatinny Arsenal, NJ 07806-5000	1	WL/MNOI Eglin AFB, FL 32542-5000 <u>Aberdeen Proving Ground</u>
1	Director Benet Weapons Laboratory U.S. Army Armament Research, Development, and Engineering Center ATTN: SMCAR-CCB-TL Watervliet, NY 12189-4050	2	Dir, USAMSAA ATTN: AMXSY-D AMXSY-MP, H. Cohen
1	Director U.S. Army Advanced Systems Research and Analysis Office (ATCOM) ATTN: AMSAT-R-NR, M/S 219-1 Ames Research Center Moffett Field, CA 94035-1000	1	Cdr, USATECOM ATTN: AMSTE-TC
		1	Dir, ERDEC ATTN: SCBRD-RT
		1	Cdr, CBDA ATTN: AMSCB-CII
		1	Dir, USARL ATTN: AMSRL-SL-I
		10	Dir, USARL ATTN: AMSRL-OP-CI-B (Tech Lib)

No. of Copies	Organization	No. of Copies	Organization
10	Central Intelligence Agency OIR/DB/Standard GE47 HQ Washington, DC 20505	1	Deputy Under Secretary of the Army for Operations Research ATTN: SAUS-OR (Hon Walt Hollis) The Pentagon, Room 2E660 Washington, DC 20310-0102
1	HQDA DAML-FIT (COL Everson) WASH, DC 20310-1001	1	OUSD(A), ODT&E/LFT ATTN: COL Paul Severance, Mil Asst. The Pentagon, Room 3E1060 Washington, DC 20301-3001
1	HQDA DAMO-ZD (Mr. Riente) The Pentagon, Rm 3A538 WASH, DC 20310-0410	2	OUSD(A), ODT&E/LFT ATTN: James O'Bryon, Deputy Director Albert E. Rainis The Pentagon, Room 3E1060 Washington, DC 20301-3001
1	HQDA SARD-DO (Mr. Ron Minarchik) WASH, DC 20310-0102	1	SAF/AQT (Mr. George Warren) The Pentagon, Rm BE939 Washington, DC 20330-1000
1	HQDA SARD-DOV (COL Steve Dasher) WASH, DC 20310-0103	1	Assistant Deputy Under Secretary of the Navy ATTN: Fred Crowson Crystal Plaza 5, Room 162 2211 Jefferson Davis Hwy. Arlington, VA 22202
1	HQDA OUSDA(A), DDRE(T&E) ATTN: COL Bernard (Chip) B. Ferguson The Pentagon WASH, DC 20301-3110	9	Defense Advanced Research Projects Agency ATTN: Mr. B. Bandy Mr. R. Kahn Dr. C. Kelly Mr. P. Losleben Dr. J. Lupo Mr. F. Patten Dr. Reynolds Mr. S. Squires COL J. Thorpe 3701 North Fairfax Drive Arlington, VA 22203-1714
2	HQDA OUSD(A), DDDRE(R&AT-ET) ATTN: Mr. Rick Menz / Dr. James Short The Pentagon, Rm 3D1089 WASH, DC 20301-3080	2	Central Intelligence Agency ATTN: ORD/PERD (Ray Cwiklinski) (Tom Kennedy) Washington, DC 20505
1	HQDA (Limres Study Group) ATTN: Shirley D. Ford The Pentagon, Room 1B929 WASH, DC 20310	1	Central Intelligence Agency ATTN: ORD/IERD (J. Fleisher) Washington, DC 20505
1	Office of the Assistant Secretary of the Army (Research, Development, and Acquisition) ATTN: LTG Cianciolo, Military Deputy Washington, DC 20310-0100		
1	Office of the Secretary of the Army (Research, Development, and Acquisition) ATTN: MG Beltson, Deputy for Systems Management Washington, DC 20310-0103		
1	Office of Deputy Director of Defense, R&E ATTN: Dr. William Snowden The Pentagon, Room 3D359 Washington, DC 20301		

No. of Copies	Organization	No. of Copies	Organization
2	Central Intelligence Agency ATTN: OIA (Barbara A. Kroggel) (Monica McGuinn) Washington, DC 20505	3	Director U.S. Army Research Office ATTN: SLCRO-MA (Dr. J. Chandra) (Dr. K. Clark) (Dr. Wu) P.O. Box 12211 Research Triangle Park, NC 27709-2211
1	Central Intelligence Agency ATTN: ORD (Donald Gerson) 1820 N. Fort Myer Drive Arlington, VA 22209	2	Director U.S. Army Survivability Management Office ATTN: SLCSM-C31 (H. J. Davis) SLCSM-D (COL H. Head) 2800 Powder Mill Road Adelphi, MD 20783-1145
1	Chief of Naval Operations OP-332D ATTN: Mr. Chuck Bogner Rm 4D537, The Pentagon Washington, DC 20350-2000	4	Commander U.S. Army ARDEC ATTN: SMCAR-CCH-V (Paul H. Gemmill) SMCAR-FSS-E (Jack Brooks) SMCAR-TD (Jim Killen) SMCAR-TDS (Vic Lindner) Picatinny Arsenal, NJ 07806-5000
1	Department of the Navy ATTN: RADM Charles R. McGrail, Jr. Pentagon, Room 4E536 Washington, DC 20350-2000	2	Commander Belvoir Research, Development and Engineering Center ATTN: STRBE-FC (Ash Patil) STRBE-JDA (Melvin Goss) Fort Belvoir, VA 22060-5606
4	Commander U.S. Army Materiel Command ATTN: AMCDE-PI (Dan Marks) AMCSI (Dr. R. Chait) AMCPD (Darold Griffin) AMCPD-PT (Alan Elkins) 5001 Eisenhower Avenue Alexandria, VA 22333-0001	1	Commander, USACECOM R&D Technical Library ATTN: ASQNC-ELC-IS-L-R, Myer Center Fort Monmouth, NJ 07703-5000
4	Commander U.S. Army Research Laboratory ATTN: AMSRL-CP-PA (K. Zastrow) AMSRL-CP-CC (J. Predham) AMSRL-CP-CC (D. Smith) AMSRL-SS-M (Marcos Sola) 2800 Powder Mill Road Adelphi, MD 20783-1145	3	Director Center for Night Vision and Electro-Optics ATTN: AMSEL-RD-NV-V (John Palmer) AMSEL-RD-NV-V (John Ho) AMSEL-RD-NV-D (Dr. R. Buser) Fort Belvoir, VA 22060-5677
1	Commandant U.S. Army Logistics Management College ATTN: AMXMC-LS-S (CPT(P) S. Parker) Ft. Lee, VA 23801		
1	Director Combat Development U.S. Army Transportation School ATTN: COL Elijah Toney Ft. Eustis, VA 23604		

No. of Copies	Organization	No. of Copies	Organization
7	Commander U.S. Army Foreign Science & Technology Ctr ATTN: AIFR (Bill Rich) MSIC (T. Walker) MSIC (R. Wittnebel) AIFRS (Gordon Spencer) AIFRS (Dr. Steven Carter) AIFRT (John Kosiewicz) AIFRE (S. Eitelman) 220 Seventh Street, NE Charlottesville, VA 22901-5396	1	Commander U.S. Army Tank-Automotive Command ATTN: AMCPM-BLK-III (COL Don Derrah) Warren, MI 48397-5000
		3	Commander U.S. Army Tank-Automotive Command ATTN: AMSTA-CK (M. Erickson) AMSTA-CK (Newell) AMSTA-RSK (Sam Goodman) Warren, MI 48090-5000
3	Director U.S. Army Missile & Space Intelligence Ctr ATTN: AMSMI-RD-GC-T (R. Alongi) AMSMI-RD-SS-AT (Ed Vaughn) AMSMI-RD (J. Bradas) Redstone Arsenal, AL 35898-5000	6	Commander U.S. Army Tank-Automotive Command ATTN: AMSTA-ZE (R. Asoklis) AMSTA-ZEA (C. Robinson) AMSTA-ZEA (R. Gonzalez) AMSTA-ZS (D. Rees) AMSTA-ZSS (J. Thompson) AMSTA-ZSS (J. Soltez) Warren, MI 48397-5000
1	Director U.S. Army Missile & Space Intelligence Ctr ATTN: AMSMI-YTSD (Glenn Allison) Redstone Arsenal, AL 35898-5070	1	Office of the PEO, Armored Sys Mod ATTN: SFAE-ASM-CV (Brian Bonkosky) Warren, MI 48397-5000
8	Director U.S. Army Missile and Space Intelligence Ctr ATTN: AIMS-RT (Pat Jordan) AIMS-YLD (Vernon L. Stallcup) AIMS-YRS (Thomas Blalock) AIMS-YRS (Pete Kirkland) AIMS-YRT (Francis G. Cline) AIMS-YRT (Don A. Slaymaker) AMSMI-REX (W. Pittman) Randy L. Smith Redstone Arsenal, AL 35898-5500	1	Commander HQ, TRADOC ATTN: Asst Dep Chief of Staff for Combat Operations Fort Monroe, VA 23651-5000
10	Commander U.S. Army Tank-Automotive Command ATTN: AMSTA-NKS (D. Cyaye) AMSTA-CR (Mr. Wheelock) AMSTA-CV (COL Becking) AMSTA-NKS (J. Rowe) AMSTA-RG (R. Munt) AMSTA-RG (R. McClelland) AMSTA-RSC (John Bennett) AMSTA-RSC (Wally Mick) AMSTA-RY (Ron Beck) AMSTA-JCS-RSC (Jim Revello) Warren, MI 48397-5000	1	Commander TRADOC ATTN: ATAN-AP (Mark W. Murray) Ft. Monroe, VA 23651-5143
		1	Director U.S. Army Engineer Waterways Experiment Station ATTN: CEWES-SE (Charles Joachim) 3909 Halls Ferry Road Vicksburg, MS 39180-6199
		1	Director U.S. Army Cold Regions Research and Development Laboratory ATTN: Technical Director (Lewis Link) 72 Lyme Road Hanover, NH 03755

No. of Copies	Organization	No. of Copies	Organization
1	U.S. Army Corps of Engineers Assistant Director R&D Directorate ATTN: Mr. B. Benn 20 Massachusetts Avenue, NW Washington, DC 20314-1000	3	Director U.S. Army Engineer Waterways Experiment Station ATTN: WESEN (Dr. V. LaGarde) WESEN (Mr. W. Grabau) WESEN-C (Mr. David Meeker)
1	Commander U.S. Army Operational Test & Evaluation Agency ATTN: MG Stephenson 4501 Ford Avenue Alexandria, VA 22302-1458		PO Box 631 Vicksburg, MS 39180-0631
1	Commander U.S. Army Vulnerability Assessment Laboratory ATTN: SLCVA-CF (Gil Apodaca) White Sands Missile Range, NM 88002-5513	1	PM-AFAS ATTN: SFAE-ASM-AF-E (T. Kuriata) Picatinny Arsenal, NJ 07806-5000
1	Director TRAC-WSMR ATTN: ATRC-RD (McCoy) WSMR, NM 88002-5502	4	Commander David Taylor Research Center ATTN: Code 1702 (Mr. Robert Wunderlick) Code 1740.2 (Mr. Fred J. Fisch) Code 1750 (Mr. William Conley) Code 1702 (Mr. Peter Gaus) Bethesda, MD 20084-5000
2	U.S. General Accounting Office Program Evaluation & Methodology Division ATTN: Robert G. Orwin Joseph Sonnefeld Room 5844 441 G Street, NW Washington, DC 20548	1	Director Lawrence Livermore National Laboratory ATTN: Mark Wilkins (L-3321) PO Box 808 Livermore, CA 94551
1	Director U.S. Army Model Improvement and Study Management Agency ATTN: SFUS-MIS (Eugene P. Visco) Crystal Square 2, Suite 808 1725 Jefferson Davis Highway Arlington, VA 22202	2	Director Los Alamos National Laboratory ATTN: Dean C. Nelsen, MS 985 Terrence Phillips, MS G787 PO Box 1663 Los Alamos, NM 87545
2	Director U.S. Army Industrial Base Engineering Activity ATTN: AMXIB-MT AMXIB-PS (Steve McGlone) Rock Island, IL 61299-7260	1	Director Los Alamos National Laboratory ATTN: LTC Michael V. Ziehm, MS F681 USMC PO Box 1668 Los Alamos, NM 87545
1	U.S. Army Engineer Topographic Laboratories ATTN: Technical Director (W. Boge) Fort Belvoir, VA 22060-5546	1	Director Los Alamos National Laboratory ATTN: Dr. Roy A. Lucht, MS J960 Group M-B Los Alamos, NM 87545

No. of Copies	Organization
1	Director Sandia National Laboratories ORG. 2300 ATTN: Ron Andreas, Director P.O. Box 5800 Albuquerque, NM 87185-5800
1	Director Sandia National Laboratories Division 1611 ATTN: Tom James Albuquerque, NM 87185
1	Director Sandia National Laboratories Division 1623 ATTN: Larry Hostetler Albuquerque, NM 87185
1	Director Sandia National Laboratories ATTN: Gary W. Richter PO Box 969 Livermore, CA 94550
1	Commander U.S. Naval Air Systems Command JTCG/AS Central Office ATTN: 5164J (LTC James B. Sebolka) Washington, DC 20361
1	Commander ADR PM, Code AIR-41112I ATTN: Tom Furlough Naval Air Systems Command Washington, DC 20361-4110
1	Commander U.S. Naval Ocean Systems Center ATTN: Earle G. Schweizer, Code 000 San Diego, CA 92151-5000
4	Commander U.S. Naval Surface Warfare Center ATTN: Gregory J. Budd James Ellis Barbara J. Harris Constance P. Rollins Code G13 Dahlgren, VA 22448-5000

No. of Copies	Organization
3	Commander Naval Surface Warfare Center ATTN: Glen Hornbaker, Code G102 George Williams, Code J33 Thomas Wasmund, Code G29 Dahlgren, VA 22448-5000
5	Commander U.S. Naval Surface Warfare Center ATTN: Frank Fassnacht, Code N15 Norma D. Holland, Code R14 William McDonald, Code R14 Dr. F. E. Baker William Emberson, Code H021 10901 New Hampshire Ave. Silver Spring, MD 20903-5000
1	Commander U.S. Naval Surface Warfare Center ATTN: M. John Timo 10509 Edgefield Drive Adelphi, MD 20783-1130
2	Commander U.S. Naval Weapons Center ATTN: Jay Butterworth, Code 3951 Dr. Helen Wang, Code 3951 Bldg 1400, Room B20 China Lake, CA 93555-6001
9	Commander U.S. Naval Weapons Center ATTN: David H. Hall, Code C218 Mark D. Alexander, Code 3894 Melvin H. Keith, Code C28104 John Manion, Code 3386 Tim Horton, Code 3386 Robert Cox, Code C2817 Rex Randolph, Code C2817 William Tonkin, Code 35104 Terry J. Wilson, Code C281 China Lake, CA 93555-6001
1	Commander U.S. Naval Civil Eng Laboratories ATTN: John M. Ferritto, Code L53 Port Hueneme, CA 93043

No. of Copies	Organization	No. of Copies	Organization
1	Naval Postgraduate School Dept of Aeronautics & Astronautics ATTN: Prof. Robert E. Ball Monterey, CA 93943	1	Commander U.S. Naval Sea Systems Command ATTN: CPT R. Percival USN, SEA 05T 2521 Jefferson Davis Hwy. Arlington, VA 22202
1	Naval Postgraduate School ATTN: Dr. Michael J. Zyda, Code 52 Department of Computer Science Monterey, CA 93943-5000	1	Commander Space & Naval Warfare Systems Command ATTN: Paul Wessel, Code 30T Washington, DC 20363-5100
1	Naval Postgraduate School Department of National Security ATTN: Dr. Joseph Sternberg, Code 73 Monterey, CA 93943	2	Commander David W. Taylor Ship & Development Ctr. ATTN: W. Conley, J. Schot Bethesda, MD 20084
1	Commander Naval Air Systems Command ATTN: Philip Weinberg, AIR-516J Washington, DC 20361-5160	1	Office of Naval Technology ATTN: David J. Siegel 800 N. Quincy Street Arlington, VA 22217-5000
1	Commander Naval Sea Systems Command ATTN: William Boyce, Code 56Y52 Washington, DC 20362	1	Commander 46 TW/EAL 104 Cherokee Avenue ATTN: Robert L. Stovall Eglin AFB, FL 32542-5000
1	Commander U.S. Naval Sea Systems Command ATTN: Granville Broome, SEA 5011 2521 Jefferson Davis Hwy. Arlington, VA 22202	2	WL/MNMW Mr. John A. Collins Dr. Bill Cook Eglin AFB, FL 32542-5434
3	Commander U.S. Naval Sea Systems Command ATTN: Philip Covich, SEA 55X CPT Charles Calvano, SEA 50 Robert Keane, SEA 50 Washington, DC 20362-5101	1	Commander AFEWC/SAXE Mr. Bob Eddy Kelly AFB, TX 78243-5000
2	Commander U.S. Naval Sea Systems Command ATTN: Oliver F. Braxton Donald Ewing, Code 503 2521 Jefferson Davis Hwy. Arlington, VA 22202	1	Commander AFWAL/AARA ATTN: Ed Zelano Wright-Patterson AFB, OH 45433
3	Commander U.S. Naval Sea Systems Command ATTN: Anthony F. Johnson, SEA 05R2 CPT William Mahew, PMS 423 Carl H. Pohler, Code 05R23 Washington, DC 20362-5101	1	Commander AFWAL/FIES ATTN: James Hodges Sr. Wright-Patterson AFB, OH 45433-6523

No. of Copies	Organization	No. of Copies	Organization
2	USAF WL/MTI ATTN: Mr. William Russell David L. Judson Wright-Patterson AFB, OH 45433-6533	1	Commander AD/CZL ATTN: James M. Heard Eglin AFB, FL 32542-5000
2	Commander ASC/WL/FIVS ATTN: Martin Lentz Ralph Lauzze Wright-Patterson AFB, OH 45433-6553	1	Commander AD/ENYW ATTN: Jim Richardson Eglin AFB, FL 32542-5000
1	Commander WRDC/AARA ATTN: Michael L. Bryant Wright-Patterson AFB, OH 45433	1	Commander U.S. Army FSTC/CA3 ATTN: Scott Mingledorff 220 Seventh Avenue Charlottesville, VA 22901-5396
1	Commander FTD/SDMBA ATTN: Charles Darnell Wright-Patterson AFB, OH 45433	1	Commander U.S. Army FSTC (UK) ATTN: MAJ J. Garnett 220 Seventh Avenue Charlottesville, VA 22901-5396
1	Commander FTD/SDMBU ATTN: Kevin Nelson Wright-Patterson AFB, OH 45433	1	Commander U.S. Army FSTC ATTN: Dr. Tim Small 220 Seventh Avenue Charlottesville, VA 22901-5396
1	Commander FTD/SQDRA ATTN: Greg Koesters Wright-Patterson AFB, OH 45433-6508	1	Defense Intelligence Agency ATTN: DB-6E3 (Jay Hagler) Washington, DC 20340-6763
1	Commander FTD ATTN: Tom Reinhardt Wright-Patterson AFB, OH 45433	6	Institute for Defense Analysis ATTN: Mr. Irwin A. Kaufman Mr. Arthur O. Kresse Dr. Lowell Tonnessen Mr. Benjamin W. Turner Ms. Sylvia L. Waller Mr. Dave Hardison 1801 N. Beauregard Street Alexandria, VA 22311
1	Commander FTD/SDAEA ATTN: Joe Sugrue Wright-Patterson AFB, OH 45433	1	Institute for Defense Analyses ATTN: Carl F. Kossack 1005 Athens Way Sun City, FL 33570
1	Commander AFWAL/AARA ATTN: Vincent Velten Wright-Patterson AFB, OH 45433	1	Institute for Defense Analyses ATTN: Dr. Natarajan Subramonian 14309 Hollyhock Way Burtonsville, MD 20866
1	Commander FTD/SQDRA ATTN: Larry E. Wright Wright-Patterson AFB, OH 45433		

No. of Copies	Organization	No. of Copies	Organization
1	Department of Commerce National Institute of Standards and Technology Manufacturing Systems Group ATTN: B. Smith Washington, DC 20234	1	Alliant Techsystems, Inc. ATTN: Hatem Nasr Systems and Research Center 3660 Technology Drive P.O. Box 1361 Minneapolis, MN 55418
1	AAI Corporation ATTN: H. W. Schuette PO Box 126 Hunt Valley, MD 21030-0126	2	Alliant Techsystems, Inc. ATTN: Raymond H. Burg Laura C. Dillway MN50-2560 5901 Lincoln Drive Edina, MN 55436
2	American Defense Preparedness Association ATTN: Donna R. Alexander Bill King Two Colonial Place, Suite 400 2101 Wilson Boulevard Arlington, VA 22201-3061	1	Aluminum Company of America ATTN: Frank W. Baker Alcoa Technical Center Alcoa Center, PA 15069
1	Alliant TechSystems, Inc ATTN: Paul Schmidt 7225 Northland Drive Brooklyn Park, NM 55428	1	Analysis and Technology ATTN: RADM Thomas Hopkins USN (Ret) 1113 Carper Street McLean, VA 22101
1	ARC Professional Services Group ATTN: Arnold R. Gritzke 5501 Backlick Road Springfield, VA 22151	1	ANSER ATTN: James W. McNulty 1215 Jefferson Davis Highway Arlington, VA 22202
2	Advanced Marine Enterprises ATTN: James F. Hess CPT Frederic S. Hering USN (Ret) 1725 Jefferson Davis Highway Suite 1300 Arlington, VA 22202	1	ARC C-500 ATTN: John H. Bucher Modena Road Coatesville, PA 19320
1	AFELM, The Rand Corporation ATTN: Library-D 1700 Main Street Santa Monica, CA 90406	1	Armored Vehicle Technologies ATTN: Coda M. Edwards PO Box 2057 Warren, MI 48090
2	Air Force Wright Aeronautical Labs ATTN: CDJ, CPT Jost CDJ, Joseph Faison Wright-Patterson AFB, OH 45433-6523	1	ASI Systems, International ATTN: Dr. Michael Stamatelatos 3319 Lone Jack Road Encinitas, CA 92024
1	Alliston Gas Turbine Division of GM ATTN: William D. Farrar PO Box 420, SC S22B Indianapolis, IN 46260-0420	1	Auburn University Electrical Engineering Department ATTN: Dr. Thomas Shumpert Auburn University, AL 36849

No. of Copies	Organization	No. of Copies	Organization
1	A.W. Bayer and Associates ATTN: Albert W. Bayer, President Marina City Club 4333 Admiralty Way Marina del Rey, CA 90292-5469	1	Board on Army Science and Technology National Research Council Room MH 280 2101 Constitution Avenue, NW Washington, DC 20418
1	Battelle Research Laboratory ATTN: TACTEC Library (J.N. Huggins) 505 King Avenue Columbus, Ohio 43201-2693	2	Boeing Aerospace ATTN: Dr. Robert Chiavetta, MS-8K17 Dr. John Kuras, MS-8K17 P.O. Box 3999 Seattle, WA 98124-2499
1	Battelle Research Laboratory Defense and Space Systems Analysis ATTN: Dr. Richard K. Thatcher 505 King Avenue Columbus, Ohio 43201-2693	1	Boeing Military Airplanes ATTN: MS K80-08, Jerry White PO Box 7730 Wichita, KA 67277-7730
1	Battelle Research Laboratory ATTN: Bernard J. Tullington 4001 Fairfax Drive #600 Arlington, VA 22203-1617	1	Boeing Vertol Company A Division of Boeing Company ATTN: MS P30-27, John E. Lyons PO Box 16858 Philadelphia, PA 19142
3	BMJ, Division of Harsco ATTN: William J. Wagner, Jr. Ronald W. Jenkins Ed Magalski PO Box 1512 York, PA 17404	1	Booz-Allen and Hamilton, Inc. ATTN: Dr. Richard B. Benjamin Suite 131, 4141 Colonel Glenn Hwy. Dayton, OH 45431
3	Battelle Edgewood Operations ATTN: Roy Golly Gene Roecker Robert Jameson 2113 Emmorton Park Road Edgewood, MD 21040	1	Booz-Allen and Hamilton, Inc. ATTN: John M. Vice WRDC/FIVS/SURVIAC Bldg 45, Area B Wright-Patterson AFB, OH 45433-6553
1	The BDM Corporation ATTN: Edwin J. Dorchak 7915 Jones Branch Drive McLean, VA 22102-3396	1	John Brown Associates ATTN: Dr. John A. Brown PO Box 145 Berkeley Heights, NJ 07922-0145
1	Dynetics, Inc. ATTN: Mr. James Miller P.O. Box Drawer B Huntsville, AL 35814-5050	1	Chamberlain ATTN: Mark A. Sackett PO Box 2545 Waterloo, IA 50704
1	Bell Helicopter, Textron ATTN: Jack R. Johnson PO Box 482 Fort Worth, TX 76101	2	Commander Combined Arms Combat Development ATTN: ATZL-CAP (LTC Morrison) ATZL-HFM (Dwain Skelton) Ft. Leavenworth, KS 66027-5300

No. of Copies	Organization	No. of Copies	Organization
1	Computer Sciences Corporation Integrated Systems Division ATTN: Abner W. Lee 9668 Highway 20 West, Suite 1 Madison, AL 35758	1	University of Dayton Graduate Engineering and Research Kettering Lab 262 ATTN: Dr. Gary Thiele, Director Dayton, OH 45469
1	CRS Sirrinc, Inc. ATTN: Dr. James C. Smith PO Box 22427 1177 West Loop South Houston, TX 77227	1	Defense Nuclear Agency Structural Dynamics Section ATTN: Tom Tsai Washington, DC 20305
2	Cypress International ATTN: James Logan August J. Caponecchi 1201 E. Abingdon Drive Alexandria, VA 22314	1	Delco Systems Operation ATTN: John Steen 6767 Hollister Avenue, #P202 Goleta, CA 93117
1	DATA Networks, Inc. ATTN: William E. Regan, Jr. 288 Greenspring Station Brooklandville, MD 21022	1	Dow Chemical, U.S.A ATTN: Dr. P. Richard Stoesser 1801 Building, Contract R&D Midland, MI 48674-1801
1	Datatec, Inc. ATTN: Donald E. Cudney 326 Green Acres Fort Walton, FL 32548	2	Denver Research Institute ATTN: Lawrence G. Ulyatt Larry Nutsch 2050 E. Iliff Avenue, BW 228 Denver, CO 80208
3	David Taylor Research Center ATTN: Robert E. Fuss, URED, Code 177 John R. Krezel, URED, Code 177.2 Michael Riley, URED, Code 177 Portsmouth, VA 23709-5000	1	Drexel University ATTN: Dr. Pei Chi Chou College of Engineering Philadelphia, PA 19104
10	David Taylor Research Center ATTN: Seymour N. Goldstein, Code 1210 Ib S. Hansen, Code 174 Harry Price Gray, Code 1740.4 Jackson T. Hawkins, Code 1740.2 Steven L. Cohen, Code 1230 Dennis Clark, Code 0111 Dr. Paul C. St. Hilaire, Code 1210 Richard E. Metrey, Code 01 J. William Sykes, Code 175 Herbert Wolk, Code 1740.1 Bethesda, MD 20084-5000	1	DuPont Company FPD ATTN: Dr. Oswald R. Bergmann B-1246, 1007 Market Street Wilmington, DE 19898
1	David Taylor Research Center ATTN: Arthur Marchand, Code 2843 Annapolis, MD 21042	1	Dynamics Analysis and Test Associates ATTN: Dr. C. Thomas Savell 2231 Faraday Ave Suite 103 Carlsbad, CA 92008
		1	E. I. Dupont TED FMC ATTN: Richard O. Myers Jr. Wilmington, DE 19898
		1	Eichelberger Consulting Company ATTN: Dr. Robert Eichelberger 409 West Catherine Street Bel Air, MD 21014

No. of Copies	Organization	No. of Copies	Organization
1	Electronic Warfare Associates, Inc. ATTN: William V. Chiaramonte 2071 Chain Bridge Road Vienna, VA 22180	2	BDM International ATTN: Mr. Steve Church, FX2B307 Mr. Tom Hooker, FF2B304 7915 Jones Branch Drive McLean, VA 22102-3396
1	Emprise, Ltd. ATTN: Bradshaw Armendt, Jr 201 Crafton Road Bel Air, MD 21014	1	Comarco Weapons Support Division ATTN: Robert Sewell 1201 N. China Lake Boulevard Ridgecrest, CA 93555
1	ERIM ATTN: Stephen R. Stewart Exploitation Applications Department Image Processing Systems Division PO Box 8618 Ann Arbor, MI 48107-8618	1	FMC Corporation Defense Systems Group ATTN: Robert Burt 200 E. Randolph Drive Chicago, IL 60601
1	E-OIR Measurements, Inc. ATTN: Russ Moulton PO Box 1240 Spotsylvania, VA 22553-1240	1	FMC Corporation Defense Systems Group ATTN: Dennis R. Nitschke 2830 De La Cruz Blvd. P.O. Box 58123 Santa Clara, CA 95052
8	Environmental Research Institute of Michigan ATTN: Mr. K. Augustyn Mr. Kozma Dr. I. La Haie Mr. R. Horvath Mr. Arnold Mr. E. Cobb Mr. B. Morey Mr. M. Bair PO Box 134001 Ann Arbor, MI 48113-4001	1	FMC Corporation Naval Systems Division (NSD) ATTN: MK-45, Randall Ellis 4800 East River Road Minneapolis, MN 55421-1498
1	USA ETL/IAG ATTN: Jim Campbell Bldg 2592, Room S16 Ft. Belvoir, VA 22060-5546	1	FMC Corporation Northern Ordnance Division ATTN: M3-11, Barry Brown 4800 East River Road Minneapolis, MN 55421-1498
1	FMC Corporation ATTN: Sidney Kraus 1105 Coleman Ave, Box 1201 San Jose, CA 95108	6	FMC Corporation Ordnance Engineering Division ATTN: H. Croft M. Hatcher L. House J. Jackson E. Maddox R. Musante 1105 Coleman Ave, Box 1201 San Jose, CA 95108
3	FMC Corporation ATTN: Ronald S. Beck Martin Lim Jacob F. Yacoub 881 Martin Avenue Santa Clara, CA 95052		

No. of Copies	Organization	No. of Copies	Organization
1	GE Aircraft Engines ATTN: Dr. Roger B. Dunn One Neumann Way, MD J185 Cincinnati, OH 45215-6301	1	Hughes Associates ATTN: J. Thomas Hughes 6770 Oak Hall Ln #125 Columbia, MD 21045-4768
3	General Dynamics Land Systems ATTN: MZ-4362055, Gary Jackman Dr. Paulus Kersten William M. Mrdeza P.O. Box 2074 Warren, MI 48317	2	INEL/EG&G ATTN: Ray Berry M. Marx Hintze PO Box 1625 Idaho Falls, ID 83451
4	General Dynamics Corporation ATTN: MZ-5965, Dr. Fred Cleveland MZ-2650, Dave Bergman MZ-2860, John Romanko MZ-2844, Cynthia Waters PO Box 748 Ft. Worth, TX 76101-0748	1	Rensselaer Polytechnic Inst. Interactive Computer Graphics Center ATTN: M. Wozny Troy, NY 12181
6	General Dynamics Land Systems ATTN: Richard Auyer Otto Renius N. S. Sridharan Dean R. Loftin Dr. Phil Lettn Don Yustick, MZ 436-21-19 PO Box 2074 Warren, MI 48090-2074	1	International Development Corporation ATTN: Trevor O. Jones One Cleveland Center, Suite 2900 1375 East Ninth Street Cleveland, OH 44114-1724
1	General Motors Corporation Research Laboratories ATTN: R. Sarraga 30500 Mound Road Warren, MI 48090	1	Intergraph National Exploitation Systems ATTN: John H. Suter 2051 Mercator Drive Reston, VA 22091-3413
1	General Motors Corporation Allison Gas Turbine Division ATTN: Dr. John A. MacBain Low Observables Technology PO Box 420, Speed Code W-16 Indianapolis, IN 46206-0420	1	ISAT ATTN: Roderick Briggs 1305 Duke Street Alexandria, VA 22314
1	GTRI-RAIL-MAD ATTN: Mr. Joe Bradley CRB 577 Atlanta, GA 30332	1	ITT Defense ATTN: Joseph Conway 1000 Wilson Blvd., 30th Floor Arlington, VA 22209
		1	Joint Technical Coordinating Group ATTN: Philip Weinberg JTTCG/AS5 AIR-516J5 Washington, DC 20361-5160
		1	California Institute of Technology Jet Propulsion Laboratory ATTN: D. Lewis 4800 Oak Grove Drive Pasadena, CA 91109

No. of Copies	Organization	No. of Copies	Organization
1	Kaman Sciences Corporation ATTN: Timothy S. Pendergrass 600 Boulevard South, Suite 208 Huntsville, AL 35802	1	Lockheed Palo Alto Research Lab ATTN: John A. DeRuntz, JR 0/93, B/25I 3251 Hanover Street Palo Alto, CA 94304
1	Ketron, Inc. ATTN: Robert S. Bennett 901 Dulaney Valley Rd, Suite 220 Baltimore, MD 21204-2600	1	Logistics Management Institute ATTN: Edward D. Simms Jr. 6400 Goldsboro Road Bethesda, MD 20817-5886
2	Keweenaw Research Center Michigan Technological University ATTN: Bill Reynolds Allen Curran Houghton, MI 49931	1	Los Alamos Technical Associates, Inc. ATTN: Jon Davis 6501 Americas Parkway, #900 Albuquerque, NM 87110
1	Lanxido Armor Products ATTN: Dr. Robert A. Wolfe Tralee Industrial Park Newark, DE 19711	2	Los Alamos Technical Associates, Inc. ATTN: James C. Jacobs Donald M. Lund 8550 Arlington Boulevard Suite 301 Fairfax, VA 22031
1	Meredith Company ATTN: Dr. F. Paul Carlson 5001 West 80th Street Suite 500 Minneapolis, MN 55437	1	Los Alamos Technical Associates, Inc. ATTN: Thomas Giacofci 3020 Hamaker Court Fairfax, VA 22031
2	Lincoln Laboratory, MIT ATTN: Dr. Robert Shin Dr. Chuck Burt P.O. Box 73 Lexington, MA 02173	1	LTV Aerospace and Defense Company ATTN: Daniel M. Reedy PO Box 655907 Dallas, TX 75265-5907
1	Lincoln Laboratory, MIT Surveillance Systems Group ATTN: R. Barnes G. Knittel J. Kong 244 Wood Street Lexington, MA 02173-0073	3	Martin Marietta Aerospace ATTN: MP-113, Dan Dorfman MP-433, Richard S. Dowd MP-243, Thomas C. D'Isepo PO Box 555837 Orlando, FL 32855-5837
3	Lockheed-California Company ATTN: C. A. Burton R. J. Ricci M. Steinberg Burbank, CA 91520	1	Maxwell Laboratories, Inc. ATTN: Dr. Michael Holland 8888 Balboa Avenue San Diego, CA 92123-1506
		1	McDonnell Douglas Astronautic ATTN: Nikolai A. Louie 5301 Bolsa Avenue Huntington Beach, CA 92647

No. of Copies	Organization	No. of Copies	Organization
1	McDonnell Douglas, Inc. ATTN: David Hamilton PO Box 516 St. Louis, MO 63166	1	North Aircraft ATTN: Dr. Athanosis Varvatsis Mail Zone 3622/84 1 Northrop Ave Hawthorne, CA 90250
1	McDonnell Douglas, Inc. ATTN: Alan R. Parker 3855 Lakewood Blvd., MC 35-18 Long Beach, CA 90846	1	Northrop Research & Technology Center ATTN: Dr. David Donovan Garber One Research Park Palos Verdes Peninsula, CA 90274
1	Micro Electronics of North Carolina ATTN: Gershon Kedem PO Box 12889 Research Triangle Park, NC 07709	1	Norton Company ATTN: Ronald K. Bart 1 New Bond Street Worcester, MA 01606-2698
1	MIT ATTN: Dr. S. Benton RE15-416 Cambridge, MA 02139	1	The Oceanus Company ATTN: RADM Robert H. Gormley, Ret PO Box 7069 Menlo Park, CA 94026
6	The MITRE Corporation ATTN: Edward C. Brady, Vice President Dr. Robert Henderson Dr. Nicklas Gramenopoulos Dr. Narayana Srinivasan Norman W. Huddy Dr. John M. Ruddy 7525 Colshire Drive McLean, VA 22102-3184	1	Oklahoma State University College of Engineering, Architecture and Technology ATTN: Thomas M. Browder, Jr. PO Box 1925 Eglin AFB, FL 32542
2	NFK Engineering, Inc. ATTN: Dr. Michael P. Pakstys Justin W. Held 4200 Wilson Blvd. Arlington, VA 22203-1800	1	Pacific Scientific/Htl Division ATTN: Robert F. Aldrich 1800 Highland Avenue Duarte, CA 91010
1	NFK Engineering, Inc. ATTN: John J. Turner 1125 Trotting Horse Lane Great Falls, VA 22066	1	Princeton University Mathematics Department, Fine Hall ATTN: John Tukey Washington Road Princeton, NJ 08544-1000
2	NASA-Ames Research Center ATTN: Dr. Alex Woo, MS 227-2 Leroy Presley, MS 227-4 Moffett Field, CA 94035-1000	1	PRI, Inc. ATTN: W. Bushell Building E4435, Second Floor Edgewood Area-APG, MD 21010
1	NAVIR DEVCON ATTN: Frank Wenograd Code 6043 Walminstor, PA 18974	1	Rockwell International Corporation ATTN: Dr. H. Bran Tran P.O. Box 92098 Department 113/GB01 Los Angeles, CA 90009

No. of Copies	Organization	No. of Copies	Organization
2	Rome Air Development Center ATTN: RADC/IRRE, Peter J. Costianes RADC/OCTM, Edward Starczewski Building 106 Griffis Air Force Base, NY 13441-5700	1	Simula, Inc. ATTN: Joseph W. Coltman 10016 South 51st Street Pheonix, AZ 85044
1	S-Cubed ATTN: Michael S. Lancaster 1800 Diagonal Road, Suite 420 Alexandria, VA 22314	1	SimTech ATTN: Dr. Annie V. Saylor 3307 Bob Wallace Ave., Suite 4 Huntsville, AL 35807
1	Sachs/Freeman Associates, Inc. ATTN: Donald W. Lynch 205 Yoakum Parkway, #511 Alexandria, VA 22304	1	Alan Smolen and Associates, Inc. ATTN: Alan Smolen, President One Cynthia Court Palm Coast, FL 32027-8172
1	SAIC ATTN: Dr. Alan J. Toepfer 2109 Air Park Drive, SE Albuquerque, NM 87106	3	Southwest Research Institute ATTN: Martin Goland Alex B. Wenzel Patrick H. Zabel P.O. Drawer 28255 San Antonio, TX 78228-0255
1	SAIC ATTN: John H. McNeilly, 1710 Goodridge Drive McLean, VA 22102	3	Sparta, Inc. ATTN: David M. McKinley Robert E. O'Connor Karen M. Rooney 4901 Corporate Drive Huntsville, AL 35805-6201
2	SAIC ATTN: Terry Keller Robert Turner 1010 Woodman Drive, Suite 200 Dayton, OH 45432	1	SRI International ATTN: Donald R. Curran 333 Ravenswood Ave. Menlo Park, CA 94025
2	George Sharp Company ATTN: Dennis M. McCarley Roger O. Mau 2121 Crystal Drive, Suite 714 Arlington, VA 22202	1	Star Laboratory, Stanford University ATTN: Dr. Joseph W. Goodman Electrical Engineering Department 233 Durand Building Stanford, CA 94305-4055
1	Sidwell-Ross and Associates, Inc. ATTN: LTG Marion C. Ross, USA (Ret) PO Box 88531 Atlanta, GA 30338	1	University of Michigan ATTN: Dr. John F. Vesecky 2212 Space Research Blvd. Ann Arbor, MI 48109-2143
1	Sigma Research Inc. ATTN: Dr. Richard Bossi 4014 Hampton Way Kent, WA 98032	1	Princeton University ATTN: Dr. Curt Callen Physics Department PO Box 708 Princeton, NJ 08544

No. of Copies	Organization	No. of Copies	Organization
1	University of California, San Diego ATTN: Dr. Gordon J. MacDonald Institute on Global Conflict and Cooperation (0518) 9500 Gilman Drive La Jolla, CA 92093-0518	1	Technical Solutions, Inc ATTN: John R. Robbins P.O. Box 1148 Mesillia Park, NM 88047
1	Structural Dynamics Research Corporation (SDRC) ATTN: R. Ard 2000 Eastman Drive Milford, OH 45150	1	Teledyne Brown Engineering ATTN: John W. Wolfsberger, Jr. Cummings Research Park 300 Sparkman Drive, NW PO Box 070007 Huntsville, AL 35807-7007
1	Syracuse Research Group ATTN: Dr. Chung-Chi Cha Merrill Lane Syracuse, NY 13210	1	Tradeways, Ltd. ATTN: Joseph G. Gorski 307F Maple Avenue West Vienna, VA 22180
1	System Planning Corporation ATTN: Ann Hafer 1500 Wilson Blvd Arlington, VA 22209	1	Ultramet ATTN: Dr. Jacob J. Stiglich 12173 Montague Street Pacoima, CA 91331
1	S-Cubed ATTN: Robert T. Sedgwick PO Box 1620 La Jolla, CA 92038-1620	1	United Technologies Corporation Advanced Systems Division ATTN: Richard J. Holman 10180 Telesis Court San Diego, CA 92121
2	TASC ATTN: Richard Kinsler Darrel James 1992 Lewis Turner Boulevard Ft. Walton Beach, FL 32548-1255	1	VP Consultants, Inc. ATTN: Mr. Albert E. Papazoni 1600 Surrey Hill Drive Austin, TX 78746-7338
1	TASC ATTN: COL James Logan (Ret) 1101 Wilson Blvd, Suite 1500 Arlington, VA 22209	1	University of Idaho Department of Civil Engineering ATTN: Dr. Dennis R. Horn Moscow, ID 83843-4194
1	COLSA, Inc. ATTN: Mr. Willy Albanes P.O. Box 1068 Huntsville, AL 35807-3301	1	University of Illinois at Chicago ATTN: Dr. Wolfgang-M. Boerner PO Box 4348 M/C 154, 1141-SEO Chicago, IL 60680
1	Techmatics, Inc. ATTN: Ronald R. Rickwald 2231 Crystal Drive Arlington, VA 22202-3742	1	University of Nevada Environmental Research Center ATTN: Dr. Delbert S. Barth Las Vegas, NV 89154-0001

No. of Copies	Organization	No. of Copies	Organization
1	University of Illinois at Urbana-Champaign Department of Civil Engineering and Environmental Studies ATTN: Dr. E. Downey Brill, Jr. 208 North Romine Urbana, IL 61801-2374	3	University of Washington 409 Department of Electrical Engineering, FT-10 ATTN: Dr. Irene Peden Dr. Akira Ishimaru Dr. Chi Ho Chan Seattle, WA 98105
1	University of Illinois at Urbana-Champaign Department of Electrical and Computer Engineering ATTN: Dr. Shung-Wu Lee 1406 W. Green Urbana, IL 61801	1	Virginia Polytechnic Institute and State University Industrial Engineering Operations Research Department ATTN: Robert C. Williges 302 Whittemore Hall Blacksburg, VA 24061-8603
1	The Johns Hopkins University Applied Physics Laboratory ATTN: Jonathan Fluss Johns Hopkins Road Laurel, MD 20707	1	LTV Aircraft Products Group ATTN: Paul T. Chau, M/S 194-63 PO Box 655907 Dallas, TX 75265-5907
1	University of North Carolina ATTN: Professor Henry Fuchs 208 New West Hall (035A) Chapel Hill, NC 27514	1	LTV Aerospace and Defense Company LTV Missiles and Electronics Group ATTN: Roger W. Melin, MS EM-36 PO Box 650003 Dallas, TX 75265-0003
3	Ohio State University Electroscience Laboratory ATTN: Dr. Ronald Marhefka Dr. Edward H. Newman Dr. Prashaker H. Pathak 1320 Kinnear Road Columbus, OH 43212	2	Wackenhut Applied Technologies Center ATTN: Robert D. Carpenter David L. Rigotti 10530 Rosehaven St., Suite 500 Fairfax, VA 22030-2877
1	University of Rochester ATTN: Nicholas George College of Engineering & Applied Science Rochester, NY 14627	1	Westinghouse ATTN: Harvey Kloehn, MS 8530 Box 1693 Baltimore, MD 21203
3	University of Utah Computer Science Department ATTN: R. Risenfeld E. Cohen L. Knapp 3160 Merrill Engineering Bldg Salt Lake City, UT 84112	1	XMCO, Inc. 460 Spring Park Pl #1500 Herndon, VA 22070-5215
		1	Zernow Tech Services, Inc. ATTN: Dr. Louis Zernow 425 West Bonita, Suite 208 San Dimas, CA 91773

No. of Copies	Organization	No. of Copies	Organization
4	SURVICE Engineering ATTN: Jim Foulk George Large Glenn Gillis Kris Keller 1003 Old Philadelphia Road, Suite 3 Aberdeen, MD 21001	1	Weidlinger Associates, Inc. ATTN: Kenneth Stultz 1735 Jefferson Davis Hwy. Suite 1002 Arlington, VA 22202
2	Sverdrup Technology ATTN: Dr. Ralph Calhoun Bud Bruenning PO Box 1935 Eglin AFB, FL 32542	1	Mr. Charles W. Bernard 5300 Columbia Pike Apt #902 Arlington, VA 22204
1	Georgia Technical Research Institute Systems and Technical Laboratory ATTN: Dr. Charles Watt 1770 Richardsons Road Smyrna, GA 30080	1	Mr. Michael W. Bernhardt, DA Consultant Rt. 1, 12 Arthur Drive Hockessin, DE 19707
1	Georgia Institute of Technology ATTN: Dr. Richard Moore ECSL/EME ERB Building, Room 111 Atlanta, GA 30332	1	Perkins Coie ATTN: Mr. Robert L. Deitz 607 Fourteenth Street, NW Washington, DC 20005-2011
1	Georgia Institute of Technology ATTN: Dr. L. G. Callahan, Jr. School of Industrial & Systems Engineering 765 Ferst Drive Atlanta, GA 30332-0385	1	Mr. Gerard W. Elverun, Jr. 1338 Fair Oaks Avenue Banning, CA 92220
1	Duke University Department of Computer Science, VLSI Raycasting ATTN: Dr. Gershon Kedem 236 North Building Durham, NC 27706	1	National Research Council ATTN: Mr. Richard E. Entlich 2101 Constitution Ave, NW Harris Building #254 Washington, DC 20418
1	Paladin Software P.O. Box 187 Aberdeen, MD 21001	1	Napadensky Energetics, Inc. ATTN: Mrs. Hyla Napadensky 650 Judson Avenue Evanston, IL 60202-2551
1	UNISYS Corporation ATTN: Calvin M. Shintani Department 7412 12010 Sunrise Valley Drive Reston, VA 22091	1	University of Iowa College of Engineering Center for Computer Aided Design ATTN: Dr. Edward J. Haug Iowa City, IA 52242
		1	Hodges Transportation, Inc. ATTN: Mr. Harry E. Cole P.O. Box 234 Carson City, NV 89702

No. of Copies	Organization	No. of Copies	Organization
1	Orincon Corporation ATTN: Mr. Robert M. Hillyer 9363 Towne Center Drive San Diego, CA 92121	1	LTGEN Howard Leaf, USAF (Ret) Director, Test and Evaluation HQ, USAF/TE Pentagon, Rm 4E995 Washington, DC 20330
1	Dr. Robert B. LaBerge 910 Via Palo Aptos, CA 95003	1	Cincinnati Mailacron Inc. ATTN: Mr. Richard C. Messinger Cincinnati, OH 45209
1	Orr Associates, Inc. ATTN: Dr. Joel N. Orr 5224 Indian River Road Virginia Beach, VA 23464	1	Coleman Research Corporation ATTN: GEN Glenn Otis, USA (Ret) 5950 Lakehurst Drive Orlando, FL 32819
1	Mr. Abraham Golub DA Consultant 203 Yoakum Parkway, Apt 607 Alexandria, VA 22304	1	MG Peter G. Olenchuk, USA (Ret) BAST Consultant 6801 Baron Road McLean, VA 22101
1	Mr. Dave Hardison ASB Consultant 3807 Bent Branch Road Falls Church, VA 22041	1	Harry Reed, Sr. Battelle Consultant 138 Edmund Street Aberdeen, MD 21001
1	Mr. William M. Hubbard, ASB Consultant 613 Eastlake Drive Columbia, MO 65203	1	Mr. David L. Rigotti McClellan Research Consultant 127 Duncannon Road Bel Air, MD 21014
1	Dr. Edward R. Jones, DA Consultant 9881 Wild Deer Road St. Louis, MO 63124	1	Dr. A. E. Schmidlin DA Consultant 28 Highview Road Caldwell, NJ 07006-5502
1	MG Robert Kirwan (USA Ret), DA Consultant 10213 Grovewood Way Fairfax, VA 22032	1	Mr. Robert G. S. Sewell 1236 Mt. Whitney Lane Ridgecrest, CA 93555
1	Director TEXCOM FSTP ATTN: STE-TFS-Z (Donald Krejcarek) Ft. Sill, OK 73503-6100	1	MEMEX, Inc. ATTN: Mr. Charles S. Smith 550 California Ave., #210 Palo Alto, CA 94306
1	Mr. Robert B. Kurtz, DA Consultant 542 Merwins Lane Fairfield, CT 06430-1920	1	Mr. Arthur Stein Consultant, IDA 30 Chapel Woods Court Williamsville, NY 14221-1816

No. of Copies	Organization	No. of Copies	Organization
1	Dr. Dora Strother ASB Consultant 3616 Landy Lane Ft. Worth, TX 76118	1	Department of the Air Force Hdq Electronic Systems Ctr (AFMC) ATTN: ESC/XRP Hanscom Air Force Base, MA 01731-5000
1	Mr. Charles F. Tiffany 2162 S. 14th Ave. Yuma, AZ 85364-6250	1	U.S. Army Missile Command TOW Project Office ATTN: SFAE-FS-TO-E-S (Brent Law) Redstone Arsenal, Alabama 35898-5000
1	Hughes Aircraft Company ATTN: Mr. Hans Tees Bldg 801, MS G26 P.O. Box 11337 Tucson, AZ 85734	1	Department of the Air Force Wright Laboratory (AFSC) ATTN: AARI-3 (Pat Woodworth) Wright-Patterson AFB, OH 45433-6543
1	ALLIANT TechSystems ATTN: Steve Gunderson MN 11-1610 600 2nd Street Northeast Hopkins, Minnesota 55343	2	Department of the Air Force ASC/XREWA ATTN: Dr. Kevin McArdle Mr. Doug McCown Eglin AFB, FL 32542
1	Headquarters U.S. Army CECOM NVEO Directorate ATTN: AMSEL-RD-NV-ISPD (Mr. Peters) Fort Belvoir, VA 22060-5677	2	Department of the Air Force ASC/XRES ATTN: Mr. H. Griffis Mr. M. Weisenback Bldg 450, 2645 50th St, Suite 19 Wright Patterson AFB, OH 45433-6503
1	Martin Marietta, ADTO ATTN: Tom Tindel 15250 Avenue of Science San Diego, CA 92128	1	Department of the Air Force ASC/XRM ATTN: Mr. Gerald B. Bennett, Jr. Wright-Patterson AFB, OH 45433-6503
1	Mr. Steve Hennessy, SSV Program Martin Marietta Mailstop H-8380 P.O. Box 179 Littleton, CO 80127	1	Department of the Air Force ASC/XRM-3 ATTN: LT Kevin Hardman Wright-Patterson AFB, OH 45433-6503
1	Pacific-Sierra Research Corp. ATTN: Steven McKay 1401 Wilson Boulevard, Suite 1100 Arlington, VA 22209	1	Commander U.S. Army Space & Strategic Defense Cmmd ATTN: SLKT (Dr. Bob Becker) P.O. Box 1500 Huntsville, AL 35807-3801
1	PM-TRADE ATTN: AMCPM-TND-A 12350 Research Parkway Orlando, Florida 32826-3276	1	Commander U.S. Army Missile Command ATTN: AMSMI-RD-ST-WF (Don Lovelace) Redstone Arsenal, AL 35898-5247

No. of
Copies Organization

- 1 Commander
Naval Air Systems Command
JTCG/AS Central Office
ATTN: Mr. John Over, AIR-516J
1421 Jefferson Davis Highway
Arlington, VA 22234-5160
- 1 Commander
Naval Surface Warfare Center
ATTN: Thomas S. Smith, Code G22
Dahlgren, VA 22448-5000
- 1 OSD/OUSD(A)/D,T&E/DDT&E/LFT
ATTN: Mr. Thomas R. Julian
The Pentagon, Rm 3D1084
Washington, DC 20301-3110
- 1 Lawrence Livermore National Lab
ATTN: Mr. Milton Finger
P.O. Box 808, Mail Stop L11
7000 E. Avenue
Livermore, CA 94550-9900
- 1 Deputy Commander
U.S. Army Strategic Defense Command
ATTN: CSSD-SL-S (Mr. Richard Berg)
P.O. Box 1500
Huntsville, AL 35807-3801
- 2 QuesTech, Inc
ATTN: Mr. Michael Eggleston
Mr. James Birnham
7600A Leesburg Pike
Falls Church, VA 22043
- 2 HQ, Defense Nuclear Agency
ATTN: MAJ Ken Bradley
Mr. Tony Frederickson
Washington, DC 20305-1000

USER EVALUATION SHEET/CHANGE OF ADDRESS

This Laboratory undertakes a continuing effort to improve the quality of the reports it publishes. Your comments/answers to the items/questions below will aid us in our efforts.

1. ARL Report Number ARL-MR-103 Date of Report September 1993

2. Date Report Received _____

3. Does this report satisfy a need? (Comment on purpose, related project, or other area of interest for which the report will be used.) _____

4. Specifically, how is the report being used? (Information source, design data, procedure, source of ideas, etc.) _____

5. Has the information in this report led to any quantitative savings as far as man-hours or dollars saved, operating costs avoided, or efficiencies achieved, etc? If so, please elaborate. _____

6. General Comments. What do you think should be changed to improve future reports? (Indicate changes to organization, technical content, format, etc.) _____

CURRENT
ADDRESS

Organization

Name

Street or P.O. Box No.

City, State, Zip Code

7. If indicating a Change of Address or Address Correction, please provide the Current or Correct address above and the Old or Incorrect address below.

OLD
ADDRESS

Organization

Name

Street or P.O. Box No.

City, State, Zip Code

(Remove this sheet, fold as indicated, tape closed, and mail.)
(DO NOT STAPLE)

DEPARTMENT OF THE ARMY

OFFICIAL BUSINESS

BUSINESS REPLY MAIL

FIRST CLASS PERMIT No 0001, APG, MD

Postage will be paid by addressee.

Director
U.S. Army Research Laboratory
ATTN: AMSRL-OP-CI-B (Tech Lib)
Aberdeen Proving Ground, MD 21005-5066



NO POSTAGE
NECESSARY
IF MAILED
IN THE
UNITED STATES

