

AD-A274 996



2

ARMY RESEARCH LABORATORY



The Construction and Operation of a New Warhead Test Facility

Gary L. Boyce
Grat E. Blackburn
Mary L. Lake
Sterling C. Shelley, Jr.
David R. Schall

ARL-TR-322

December 1993

DTIC
ELECTE
JAN 26 1994
S B D

APPROVED FOR PUBLIC RELEASE; DISTRIBUTION IS UNLIMITED.

94-02267



94 1 25 090

**Best
Available
Copy**

NOTICES

Destroy this report when it is no longer needed. DO NOT return it to the originator.

Additional copies of this report may be obtained from the National Technical Information Service, U.S. Department of Commerce, 5285 Port Royal Road, Springfield, VA 22161.

The findings of this report are not to be construed as an official Department of the Army position, unless so designated by other authorized documents.

The use of trade names or manufacturers' names in this report does not constitute indorsement of any commercial product.

DISCLAIMER NOTICE

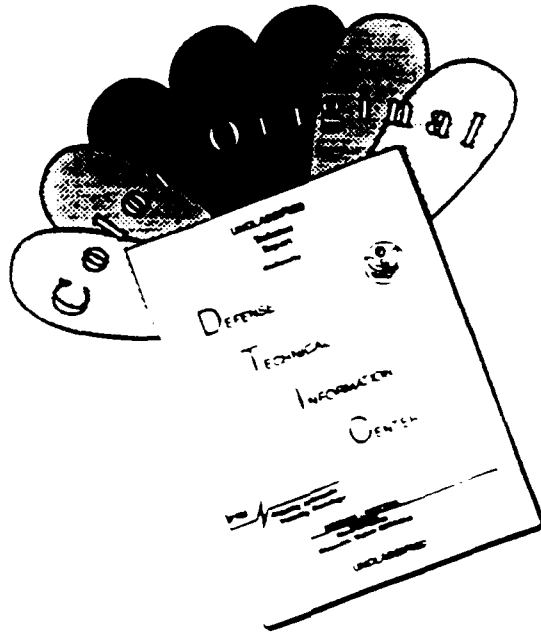

THIS DOCUMENT IS BEST QUALITY AVAILABLE. THE COPY FURNISHED TO DTIC CONTAINED A SIGNIFICANT NUMBER OF COLOR PAGES WHICH DO NOT REPRODUCE LEGIBLY ON BLACK AND WHITE MICROFICHE.

REPORT DOCUMENTATION PAGE

Form Approved
OMB No. 0704-0188

Public reporting burden for this collection of information is estimated to average 1 hour per response, including the time for reviewing instructions, searching existing data sources, gathering and maintaining the data needed, and completing and reviewing the collection of information. Send comments regarding this burden estimate or any other aspect of this collection of information, including suggestions for reducing this burden, to Washington Headquarters Services, Directorate for Information Operations and Reports, 1215 Jefferson Davis Highway, Suite 1204, Arlington, VA 22202-4302, and to the Office of Management and Budget, Paperwork Reduction Project (0704-0188), Washington, DC 20503.

1. AGENCY USE ONLY (Leave blank)		2. REPORT DATE December 1993	3. REPORT TYPE AND DATES COVERED Final, June 91 - October 91	
4. TITLE AND SUBTITLE The Construction and Operation of a New Warhead Test Facility			5. FUNDING NUMBERS PR: IL162618AH80	
6. AUTHOR(S) Gary L. Boyce, Grat E. Blackburn, Mary L. Lake, Sterling C. Shelley, Jr., and David R. Schall				
7. PERFORMING ORGANIZATION NAME(S) AND ADDRESS(ES) U.S. Army Research Laboratory ATTN: AMSRL-WT-TD Aberdeen Proving Ground, MD 21005-5066			8. PERFORMING ORGANIZATION REPORT NUMBER	
9. SPONSORING/MONITORING AGENCY NAME(S) AND ADDRESS(ES) U.S. Army Research Laboratory ATTN: AMSRL-OP-CI-B (Tech Lib) Aberdeen Proving Ground, MD 21005-5066			10. SPONSORING/MONITORING AGENCY REPORT NUMBER ARL-TR-322	
11. SUPPLEMENTARY NOTES				
12a. DISTRIBUTION / AVAILABILITY STATEMENT Approved for public release; distribution is unlimited.			12b. DISTRIBUTION CODE	
13. ABSTRACT (Maximum 200 words) An improved test facility is essential for developing warheads to be effective against future armored threats. The U.S. Army Research Laboratory (ARL) has recently completed a multichanneled flash x-ray diagnostic test facility at the Experimental Research Facility - 7A (ERF-7A). At ERF-7A, warheads are statically detonated for investigating the penetrator's interaction with complex armor designs. ERF-7A is mainly devoted to researching the performance and terminal effects of warheads. This report discusses how this modern diagnostic test facility was assembled and the events and techniques that led to its construction and operation.				
14. SUBJECT TERMS barricade, construction, techniques, keyways, warheads			15. NUMBER OF PAGES 28	
			16. PRICE CODE	
17. SECURITY CLASSIFICATION OF REPORT UNCLASSIFIED	18. SECURITY CLASSIFICATION OF THIS PAGE UNCLASSIFIED	19. SECURITY CLASSIFICATION OF ABSTRACT UNCLASSIFIED	20. LIMITATION OF ABSTRACT UL	

INTENTIONALLY LEFT BLANK.

ACKNOWLEDGMENTS

The authors wish to thank Basil H. Gaultney, a model maker for the Experimental Fabrication Branch (EFB), Site Operations Directorate, Army Research Laboratory (ARL), for his ideas and hard work in producing a working model of the basic structure and to Thomas Insley, a welder at EFB, for his hard work in the layout and fabrication of the basic structure. A special thanks to the EFB and Red River Army Depot's welding crew (temporarily assigned to ARL) for their ideas and hard work in the final construction of ERF-7A. Finally, thanks goes to Tom Ball, LB&B Associates Inc., a contractor assigned to the ARL-APG site, for the diagrams of the basic structure.

DTIC QUALITY INSPECTED 8

Accession For	
NTIS GRA&I	<input checked="" type="checkbox"/>
DTIC TAB	<input type="checkbox"/>
Unannounced	<input type="checkbox"/>
Justification	
By _____	
Distribution/	
Availability Codes	
Dist	Avail and/or Special
A-1	

INTENTIONALLY LEFT BLANK.

TABLE OF CONTENTS

	<u>Page</u>
ACKNOWLEDGMENTS	iii
LIST OF FIGURES	vii
1. INTRODUCTION	1
2. PLANNING PHASE	1
3. MATERIAL FABRICATION PHASE	6
4. CONSTRUCTION PHASE	6
5. OPERATIONAL PHASE	18
5.1 Diagnostic Equipment	21
5.2 Film Cassettes	21
6. SUMMARY	26
DISTRIBUTION LIST	27

INTENTIONALLY LEFT BLANK.

LIST OF FIGURES

<u>Figure</u>		<u>Page</u>
1.	Keyway technique	2
2.	Isometric diagram of the basic structure	4
3.	Pulser room	5
4.	Bow tie configuration	7
5.	Technique used to burn holes through armor plates	7
6.	The basic structure's foundation	8
7.	The assembled basic structure	9
8.	Keyway pin emplacement	11
9.	Pulser room's construction	11
10.	Lower level observation port covers	14
11.	Upper level observation port covers	15
12.	Placement of the upper level's port cover retainer	16
13.	Cable trough	17
14.	Assembled facility	19
15.	Firing line boxes	22
16.	The "Blackburn Wine Rack" technique	23
17.	Film cassette	24
18.	Composite of an EFP's pre-impact, target interaction, and post-impact	25

INTENTIONALLY LEFT BLANK.

1. INTRODUCTION

The U.S. Army Research Laboratory (ARL) has recently completed a multichanneled flash x-ray diagnostic test facility at the Experimental Research Facility, ERF-7A. This facility, fabricated and assembled at the ARL, can test warheads containing up to 6.804 kg of high explosive. At ERF-7A, explosively formed penetrator (EFP) and shaped charge jet (SCJ) warheads are statically detonated to investigate penetrator interaction with complex armor designs. This process is observed with the aid of radiography. ERF-7A is mainly devoted to researching the performance and terminal effects of these warheads.

EFPs are formed from a shallow dished liner into a simple penetrator, which can be lethal at extremely long standoff distances and is mainly for top attack use. EFPs may be mounted with the axis colinear with the munitions axis or transverse to it, and they may be used in spinning or nonspinning applications. SCJs typically contain a simple conical copper liner with a uniform wall thickness, although more complex geometries have been investigated. The liner is formed into an elongating jet, which can be lethal at shorter standoff distances, capable of perforating thick armors.

This report explains how the diagnostic test facility was planned and assembled. Summers and Wright (1992)¹ have developed techniques for data reduction that are applied at this facility. The methods of computer-aided digitization of the penetrator and the analysis of the penetrator characteristics and performance will not be addressed in this report since the subject is a discussion on its own. The main focus will be on the technical efforts and techniques incorporated into making the facility operational.

2. PLANNING PHASE

Construction required a scheme for the proper arrangement of materials to create an operational facility. This was an effort within ARL/Weapons Technology Directorate/Terminal Effects Division/Target Interaction Branch/Terminal Effects Team. Team meetings were used for fact gathering, which led to a finalized plan. The main question was "How can a facility be constructed without welds?" The team's decision was to design the 152-mm load-bearing walls and floors using a keyway pattern, as shown in Figure 1. Keyways require no welding once assembled. An exploded isometric drawing (scaled 100 to 1)

¹ Summers, R. L., and K. C. Wright. "Computer-Aided Analysis of Flash X-Ray Films." BRL-TR-3393, U.S. Army Ballistic Research Laboratory, Aberdeen Proving Ground, MD, September 1992.

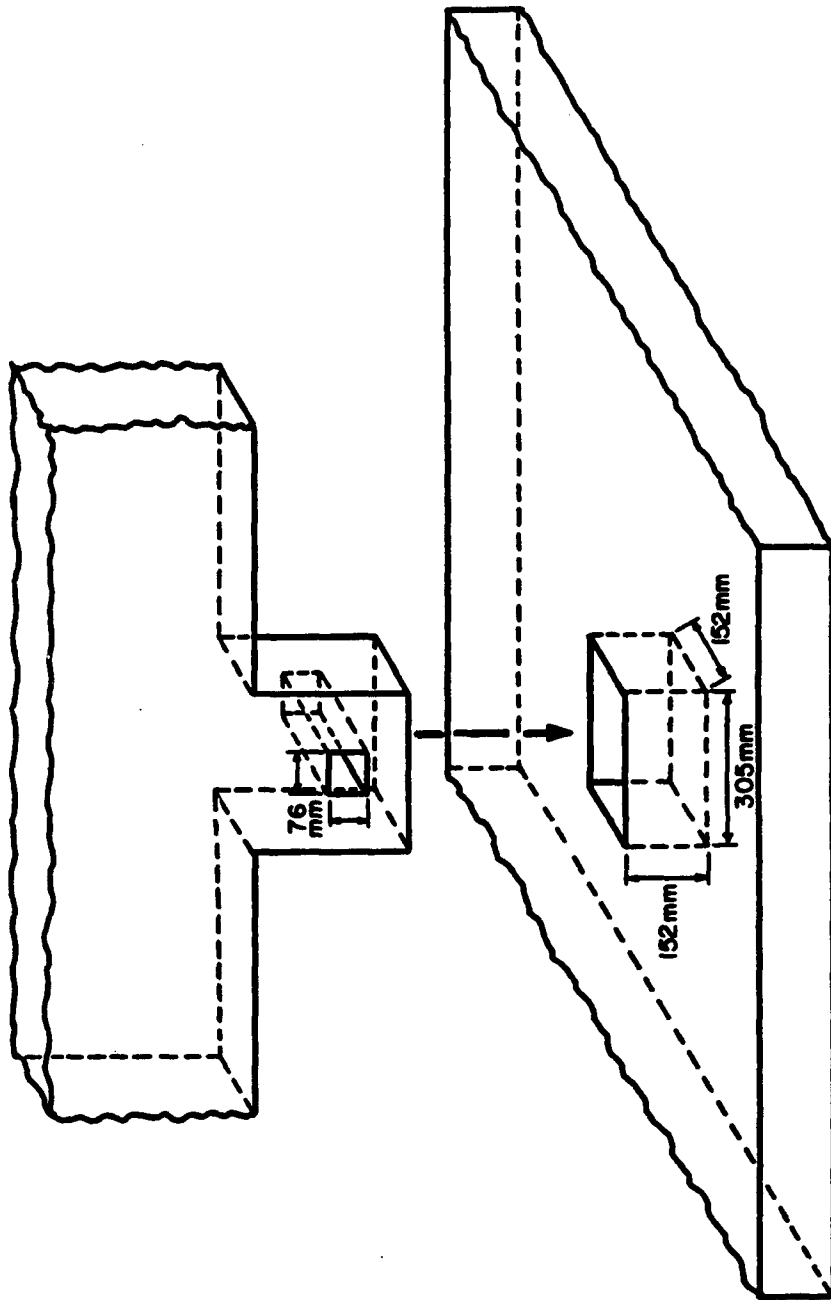

Figure 1. Keyway technique.

of the basic structure and the location of the keyways is shown in Figure 2. The basic structure would have a two-level construction. Each level would have an opening, allowing the blast pressures to escape to the atmosphere. These openings would allow easy access for materials to be placed in/out of the event areas. The purpose of the top level would be for the detonation of the warhead. The penetrator formed from the detonating warhead would be projected through a hole in the firing platform to impact a target in the bottom level. The bottom level would be used for radiographic observations of the penetrator and target interaction/penetration. A warhead (up to 2.265 kg of high explosives) could be detonated in the bottom level. However, additional protection to the film cassettes and the flash x-ray tube heads would have to be incorporated.

Since the basic structure would withstand the blast pressures and metal fragments caused by the detonating warhead, a pulser room could be constructed next to it. Thus, the pulser room, which houses the diagnostic equipment, could be assembled without fear of developing weld failure or structural damage. The materials for the pulser room's fabrication would use 212-mm x 603-mm x 13-mm rolled homogeneous armor (RHA) plates for the walls and ceiling. The floor's construction would be 212-mm x 603-mm x 25-mm RHA plates. All steel plates would be welded at all adjoining edges. To increase the pulser room's strength, 76-mm angle iron would be welded diagonally to the 13-mm-thick steel plate surface. The dimensions of the pulser room are shown in Figure 3.

Purchases of materials were made within the U.S. Army supply system. The most difficult items to purchase were 12 sheets of RHA measuring 3,658 mm x 3,658 mm x 152 mm. All other materials used for the construction of the facility were already within the supply system.

Drawings were made of the proposed facility. The facility drawings and a site location drawing were submitted to the ARL Risk Management Directorate's Risk Management Division (RMD) and the Aberdeen Proving Ground Department of Public Works (DPW). RMD had to assure that the site location and the positioning of the basic structure was within the required firing safety radius. A firing safety radius is necessary because of the restricted land size and adjacent facilities near ERF-7A. DPW studied the environmental impact of the construction of the facility. In addition, they requested that crushed stone be used for the base to support the basic structure's weight. Receipt of approvals from the DPW and RMD commenced construction of the facility.

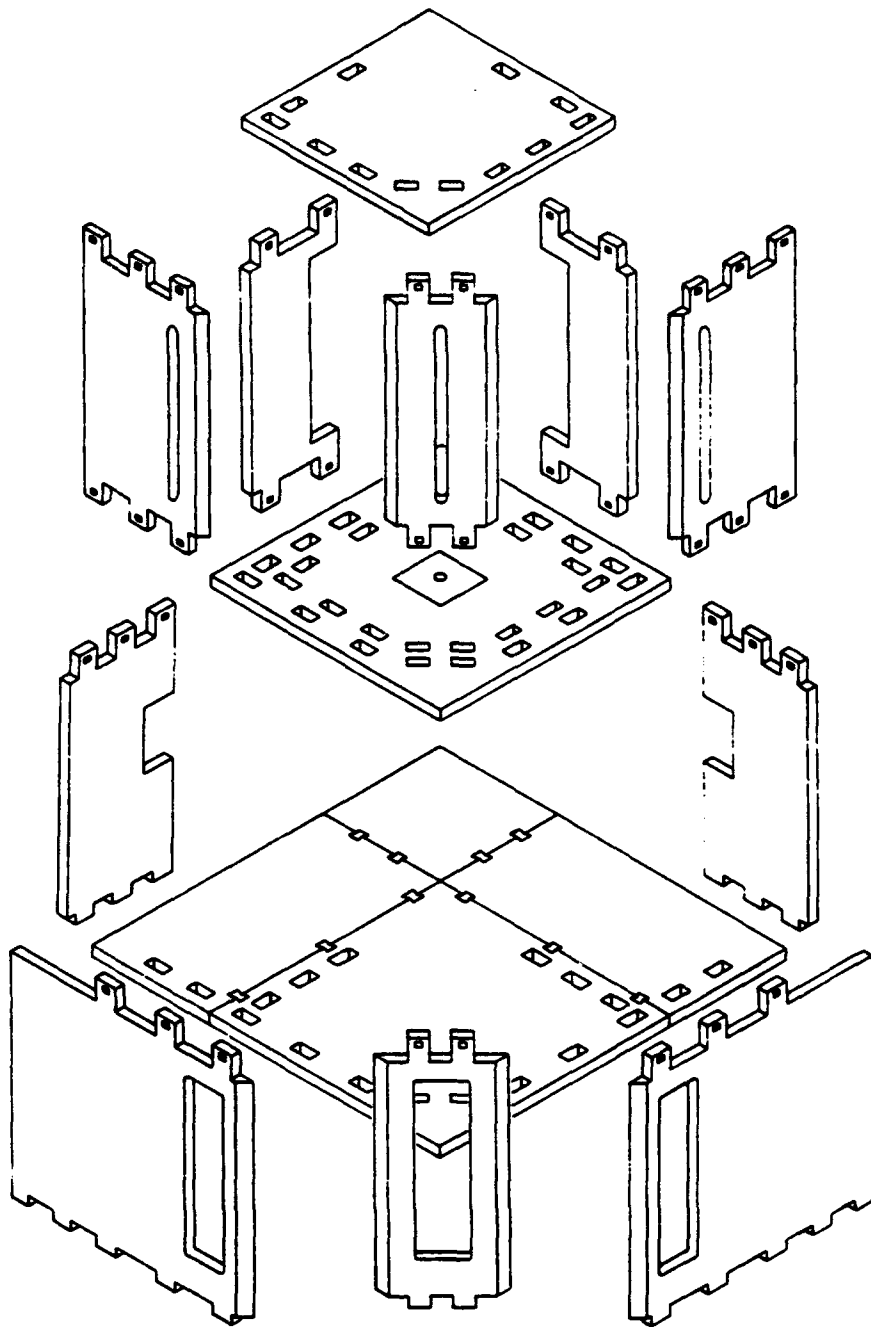

Figure 2. Isometric diagram of the basic structure.

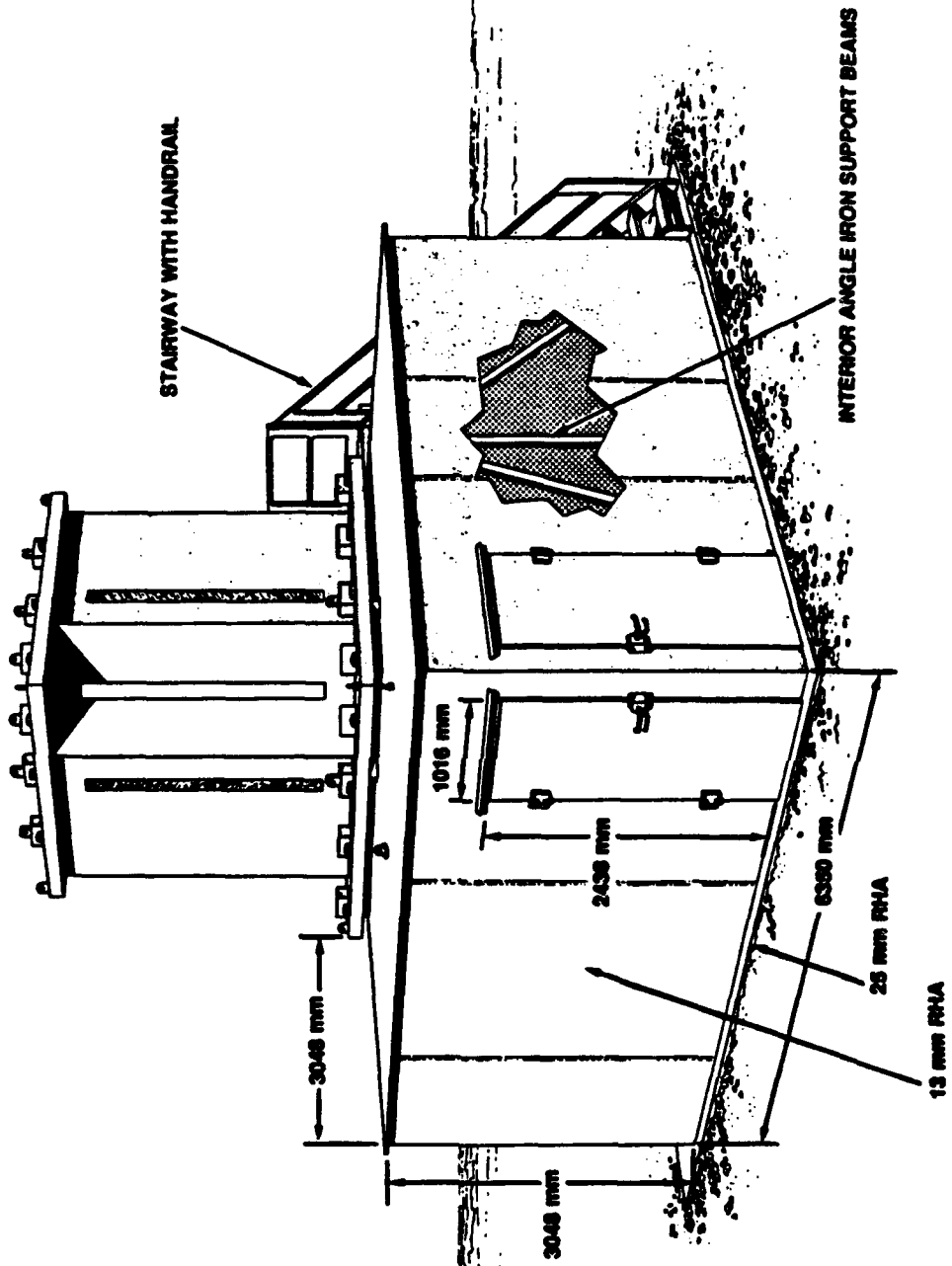

Figure 3. Pulser room.

3. MATERIAL FABRICATION PHASE

The next phase for the facility construction was having the ARL welding shop fabricate 152-mm-thick RHA plates for the basic structure. Each plate's dimensions were marked and sectioned. The subflooring was the first to be fabricated. Plates were cut with a burning torch at evenly spaced positions. Where the plates joined each other, a bow tie shape was cut. A bow tie was cut from scrap material and placed into the bow tie-shaped cavity shown in Figure 4. This technique produced an interlock between the plates and allowed the floor to float while remaining intact.

A keyway was fabricated in each 152-mm-thick RHA plate. A scaled-down plexiglass model (fabricated in ARL's carpenter shop) and drawings helped the welder find the cutting positions of each keyway. The acceptor holes for the keyways and observation ports could only be done by burning rectangles in the 152-mm-thick RHA plates. Creating a pool of molten steel, the welder placed one end of a long steel tube within the molten steel. The opposite end of the steel tube was attached to a hose, through which oxygen flowed down to the 152-mm-thick RHAs' interface, as shown in Figure 5. The welder worked the tube back and forth, and with each cycle the burning action became deeper. This process continued until a hole was burned through the 152-mm-thick RHA plate. This technique was unique because the welder was able to cut the acceptor holes (179 mm x 330 mm), the lower chamber observation ports (2,438 mm x 610 mm), and the upper chamber observation ports (2,438 mm x 102 mm) in the thick RHA plates without cutting from the outer edge of the steel plates. The female keyways were positioned 152 mm from the edge of the RHA plates. If a slot had been cut from the plate's edge, it would have weakened the basic structure.

After the welding shop completed cutting operations, each RHA plate was fitted into its proper location. This ensured that each male and female keyway would have clearance to fit in its location before leaving the welding yard. Once the basic structure was fabricated and assembled, it was disassembled and transported to ERF-7A. The basic structure was ready for final assembly.

4. CONSTRUCTION PHASE

When all the fabricated 152-mm-thick RHA plates were received at ERF-7A, the basic structure's assembly commenced. Before any steel plates were placed in their positions, the foundation was established and leveled with crusher run stone, shown in Figure 6. The foundation's base of 914 mm was

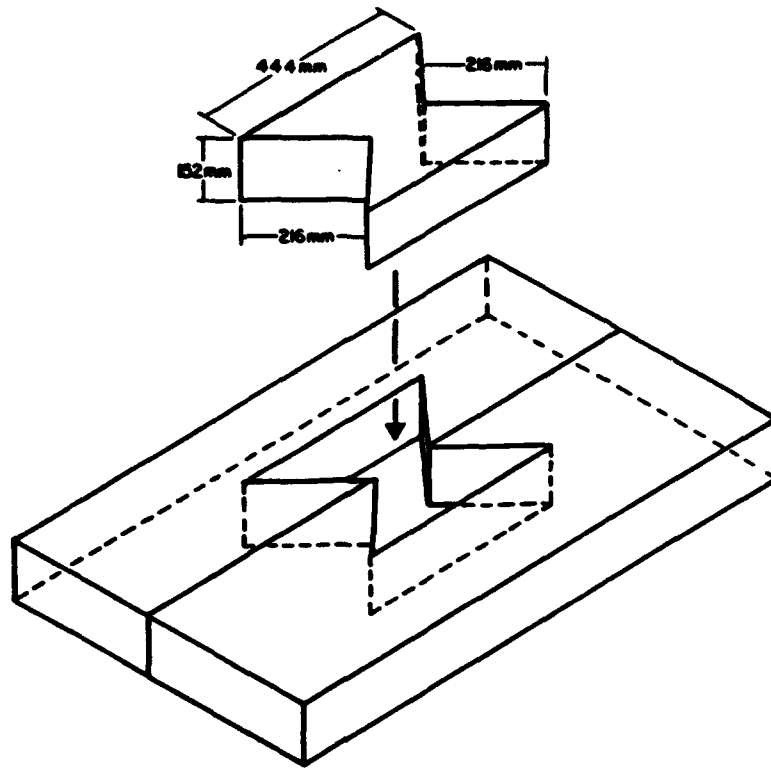

Figure 4. Bow tie configuration.

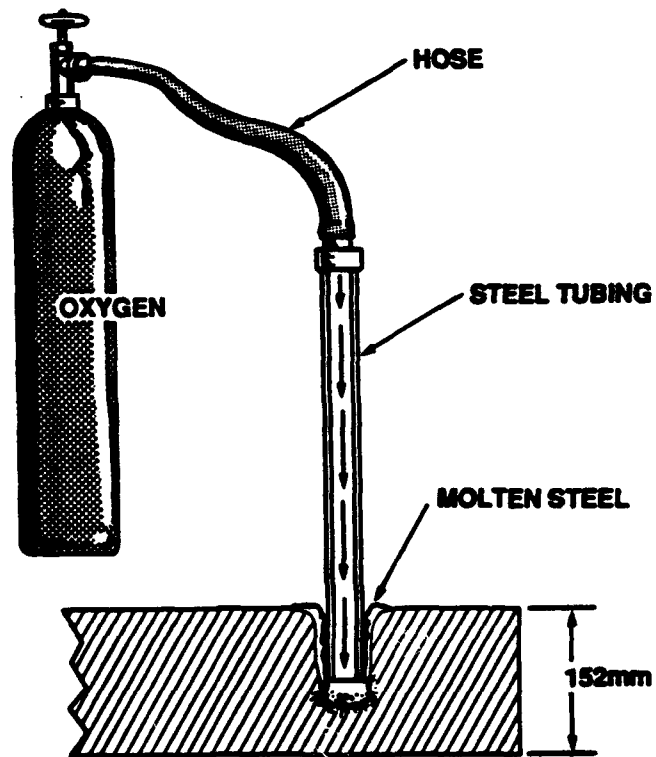

Figure 5. Technique used for burning holes through thick armor plates.

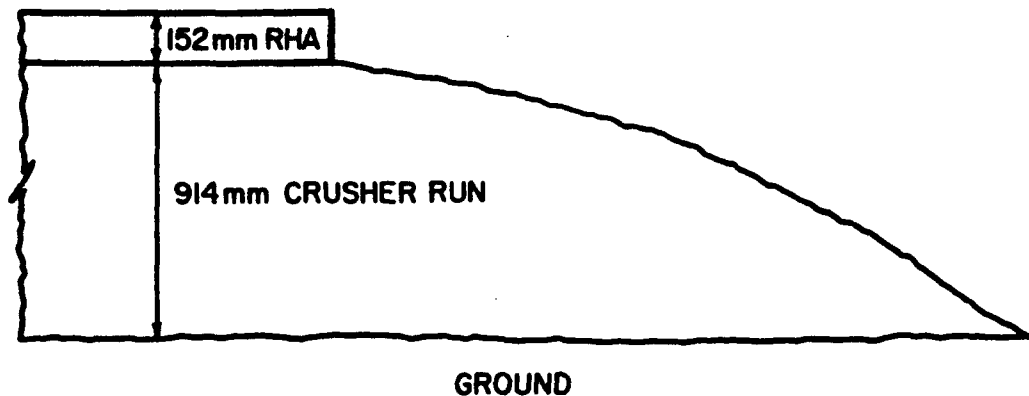

Figure 6. The basic structure's foundation.

required because of the weight in the basic structure. All 152-mm steel plates were lifted and lowered into position with a 35-ton crane. The flooring was the first of the 152-mm steel plates positioned. These steel plates had a half bow tie pattern cut at their edges. The alignment of each plate had to make a bow tie cavity at the joining edges. Once the steel plates were aligned, a 152-mm bow tie was placed into each cavity. Only one side of the bow tie was welded. The other side was free so the floor would have some movement.

The basic structure's walls and ceiling followed the same procedure. Each plate was lifted and positioned one by one. After the basic structure was assembled, shown in Figure 7, a 51-mm-square steel pin was placed at the end of the male keyway, shown in Figure 8. The steel pins keep the steel plates from moving out of the female keyways.

The pulser room was constructed following the basic structure's assembly. The pulser room was fabricated and welded at ERF-7A. The floor, walls, and ceiling did not require any special cuts for assembly, as shown in Figure 9. The pulser room was positioned around the lower level's outer area and



Figure 7. The assembled basic structure.

Following page intentionally left blank.



Figure 8. Keyway pin emplacement.



Figure 9. Pulser room's construction.

Following page intentionally left blank.

encased the observation ports. Angle iron was welded diagonally to the inside wall surfaces of the 13-mm-thick steel plates. The welded angle iron enhanced the rigidity of the pulser room walls. A steel support rack was welded to the pulser room's floor to support the pulsers, keeping them off the floor.

The observation port covers on the lower level use 25-mm-thick RHA plates. They are supported with L-shaped brackets, shown in Figure 10. These ports allow the flash x-ray tube heads output to expose certain areas on the radiographic films, which are housed in the cassettes. This technique allows the doors to be interchanged with each other, allowing various openings or no openings. The type of doors used depends on what type of penetrator is being investigated. The doors with different size openings allow the event to be captured at selected time frames and shield the radiographic film from other x-ray levels.

The upper level's observation ports are protected from the inside with 76-mm-thick steel plates having three evenly spaced 102-mm hole openings in each column. Undersized retainers are positioned through the 102-mm holes and pinned on the outside of the basic structure, shown in Figure 11. If needed, only one retainer in each column can be removed, shown in Figure 12. The steel retainers are removable from the 102-mm holes so that placement of flash x-ray tube heads can be used for additional radiographic observations.

Two additional items were fabricated—a stairway and the cable trough. Portions of these items were fabricated in the ARL shops, then transported to ERF-7A for construction. The stairway was erected for gaining access to the upper level. A steel tubular railing was welded to the basic stairs for personnel safety. The reason for a trough was for supporting the cables above the ground floor. The cables were needed to operate the diagnostic controls and detonate the warhead remotely. The cable trough, shown in Figure 13, consists of angle iron, vinyl soffit, and steel bar stock. The steel bar stock supports and elevates the trough from the ground. It is positioned at different heights depending on the terrain. Since the facility is at sea level, an abnormally high tide could flood certain areas of the facility. The main firing cable was positioned below the trough. Since stray currents generated in the diagnostic cables could cause the detonator to prefire. Separating the firing cable from the x-ray cables is a highly recommended safety feature. An inclosed cable trough in an open environment can cause many problems due to water, rodents, and wasps. ERF-7A's cable trough was assembled with an open top design. This deters the rodents from chewing the cables, and wasps from making nests. The cables are supported with

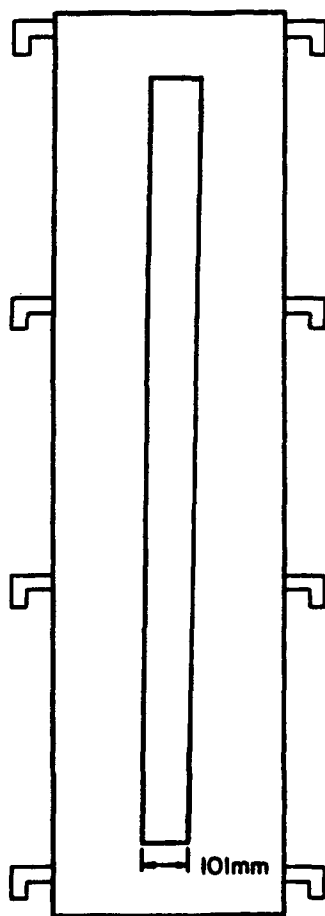

(1)
EFP Full View

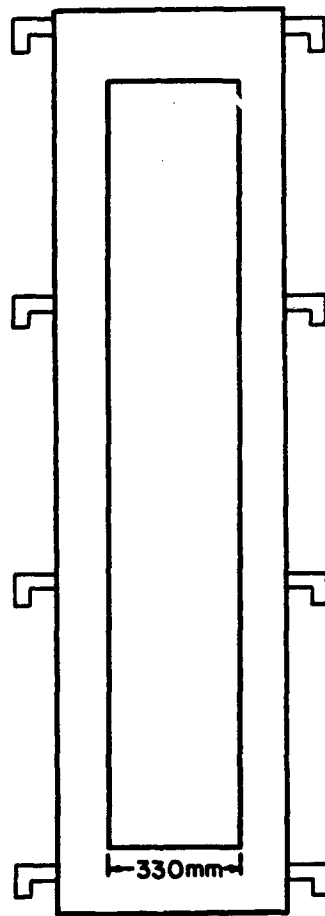

(2)
Shaped Charge Jet View

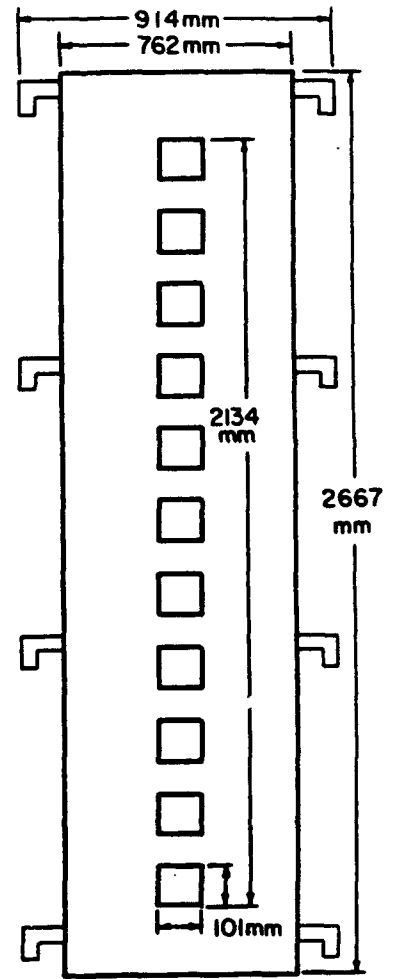

(3)
EFP Window View

Figure 10. Lower level observation port covers.

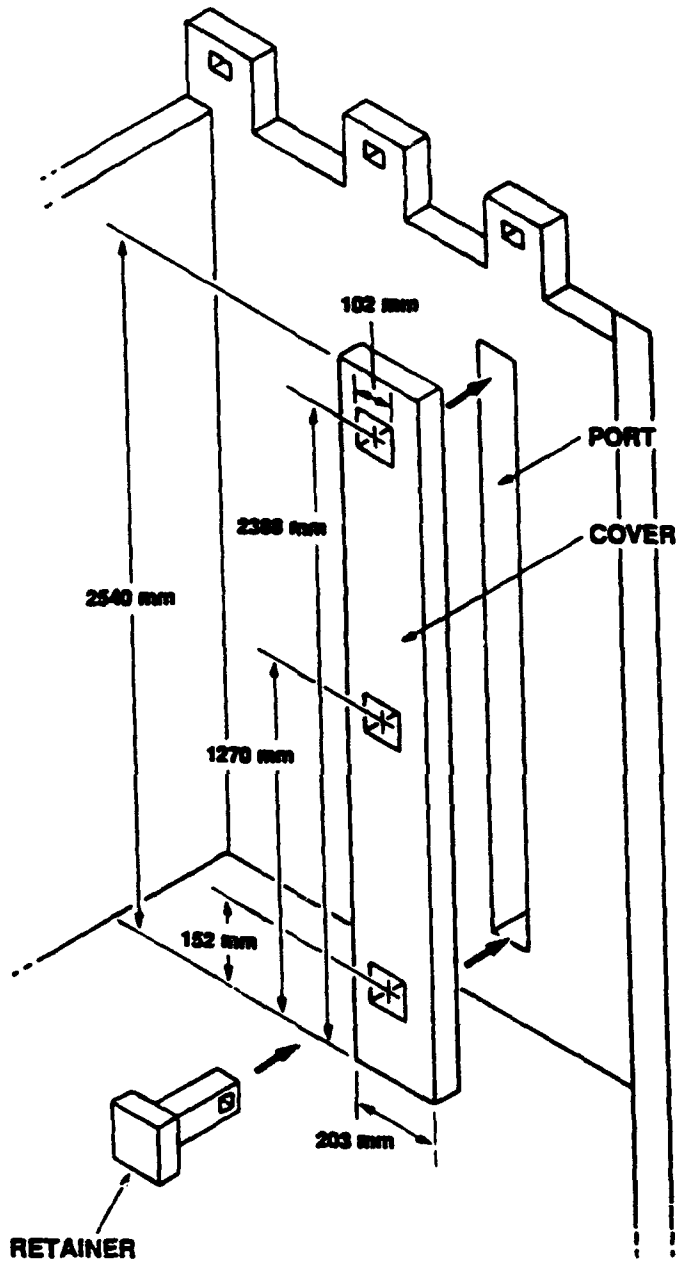

Figure 11. Upper level observation ports covers.

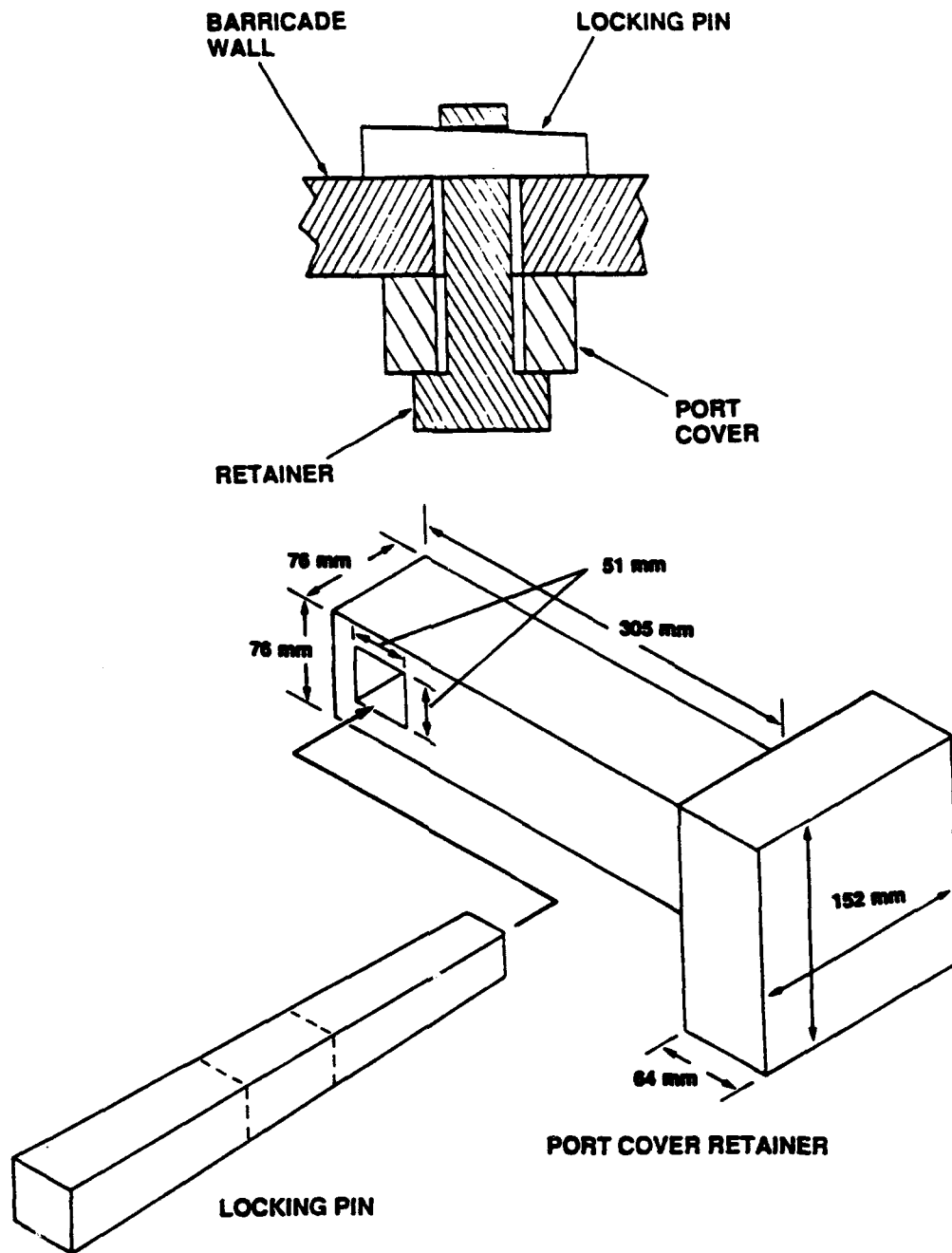

Figure 12. Placement of upper level's port cover retainer.

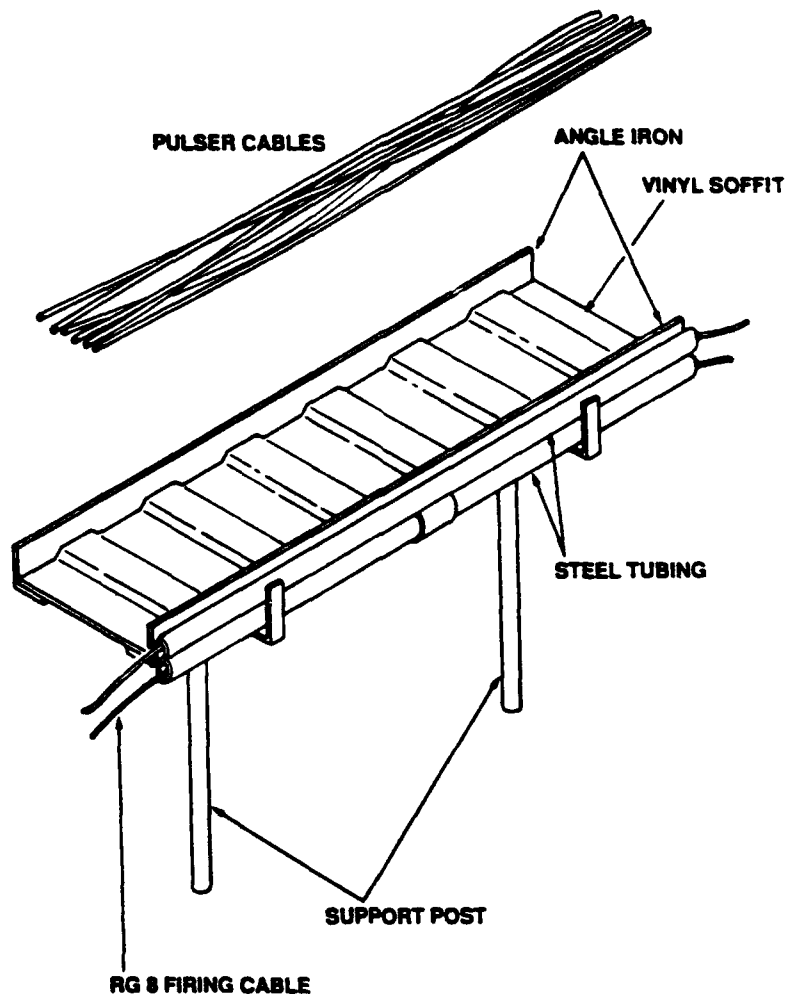

Figure 13. Cable trough.

interlocking panels of vinyl soffit that are used in the housing industry for ventilation purposes. Vinyl is a good material in this case because it allows water to drain out from the trough. Due to the interlocking design and the angle irons used for edge support, the vinyl panels have greater strength. Vinyl soffit, thus, is an inexpensive and strong material to use in this cable support technique.

When all welding was completed, the facility was sand-blasted, primed, and painted, as shown in Figure 14. ERF-7A was now ready for operational testing.

5. OPERATIONAL PHASE

After the area was cleared of scrap materials and before any diagnostic equipment was in place, a detonator function test and structural test of the facility was set up. RG-8 cables for the x-ray equipment

The Following Page Intentionally Left Blank.

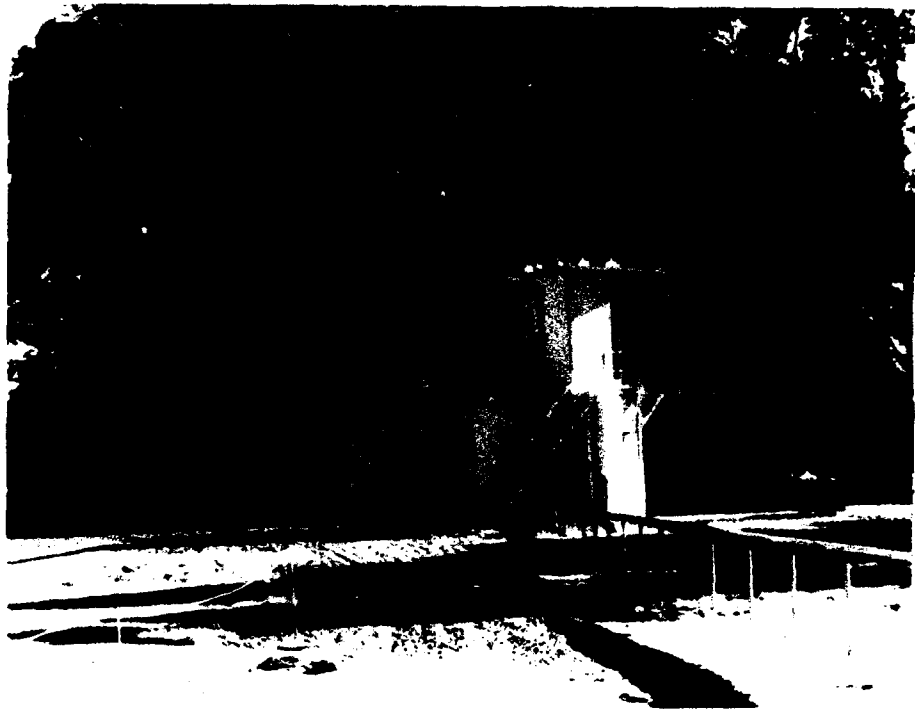
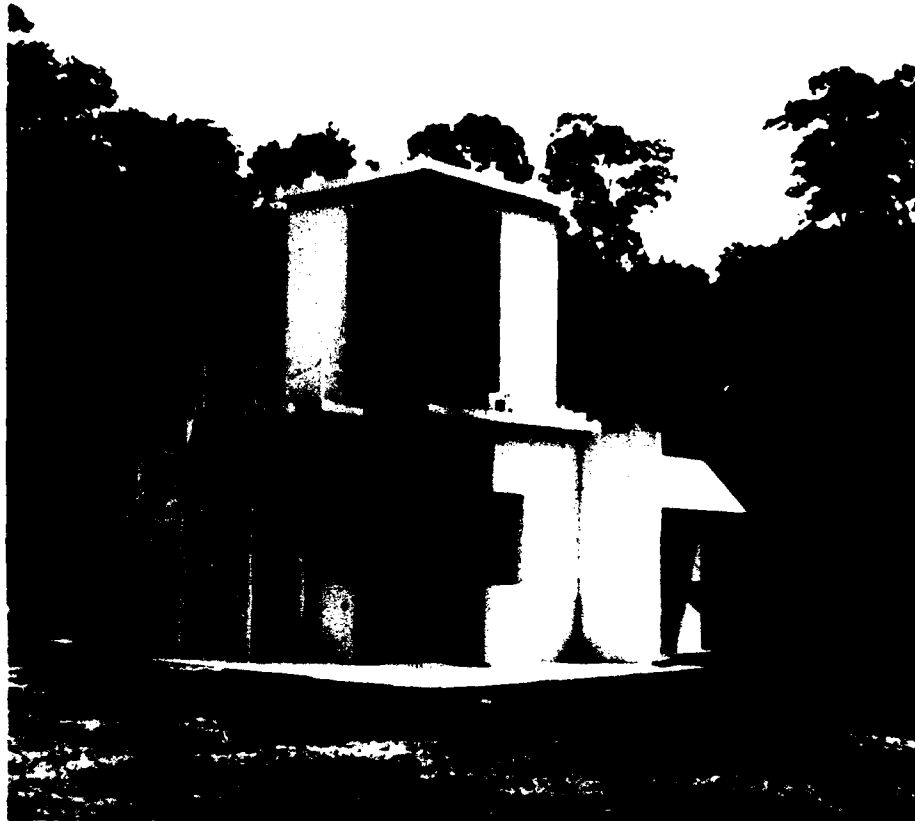

Figure 14. Assembled facility.

Following page intentionally left blank.

and firing lines were placed in the cable trough. The firing lines with transfer boxes, shown in Figure 15, were installed. These boxes keep the detonator/detonators in a closed loop until the initiation of the warhead. If stray currents are in the area, they are directed to ground. This is a required safety feature at ARL. New standard operating procedures for static detonation of various warheads were written, approved, and posted. The firing lines were tested with exploding bridge wire detonators (operational range 2.5–5.0 kV DC). These tests were to verify that the detonators functioned properly.

To verify that the basic structure was capable of handling the blast pressures from detonated warheads, five bare charge firings were conducted at the facility. Each device was cast into a right circular cylinder using a military explosive (Octol: 25% TNT and 75% HMX). The mass of each device increased for every firing conducted (1.359 kg, 2.265 kg, 3.170 kg, 4.077 kg, and 5.436 kg). The tests were conducted to observe possible structural damage to the facility. Visible inspections of the facility were conducted after each firing. Since no damage was observed from the tests, the diagnostic equipment was installed into the facility's pulser room.

5.1 Diagnostic Equipment. The facility's pulser room was equipped with ten 300-kV Hewlett-Packard pulsers and fifteen tube heads. Five of these pulsers have a dual tube head output, and the other five pulsers were set up using a single tube head output. The tube heads were arranged in three vertical columns positioned at 45° to each other. Each column was designed using the "Blackburn Winerack Technique." At this time, each column containing five tube heads are in use (shown in Figure 16). However, additional tube heads could be used. These wineracks allow tube heads to be positioned at different locations to fit the requirements of each program. For additional diagnostic coverage, three 450-kV Hewlett-Packard flash x-ray pulsers with single tube head outputs can be positioned above the pulser room and aligned to the upper level's firing area. All flash x-ray systems were installed in these positions so they could be operated separately from the firing bunker.

5.2 Film Cassettes. The barricade was designed to use long, heavy film cassettes (1,946 mm x 464 mm). These cassettes capture the penetrator events (shown in Figure 17). Three cassettes can be positioned under the firing table parallel to the tube head columns. The cassettes are supported at the bottom on a steel frame and are clamped at the top to a metal bracket. However, additional supports can be added to allow the film cassettes to be moved in or out of the flight path. This procedure only keeps the cassettes in position for alignment to the tube head columns. In every program, the distances are measured and recorded between the tube heads, flight path, and film cassettes. These measured distances

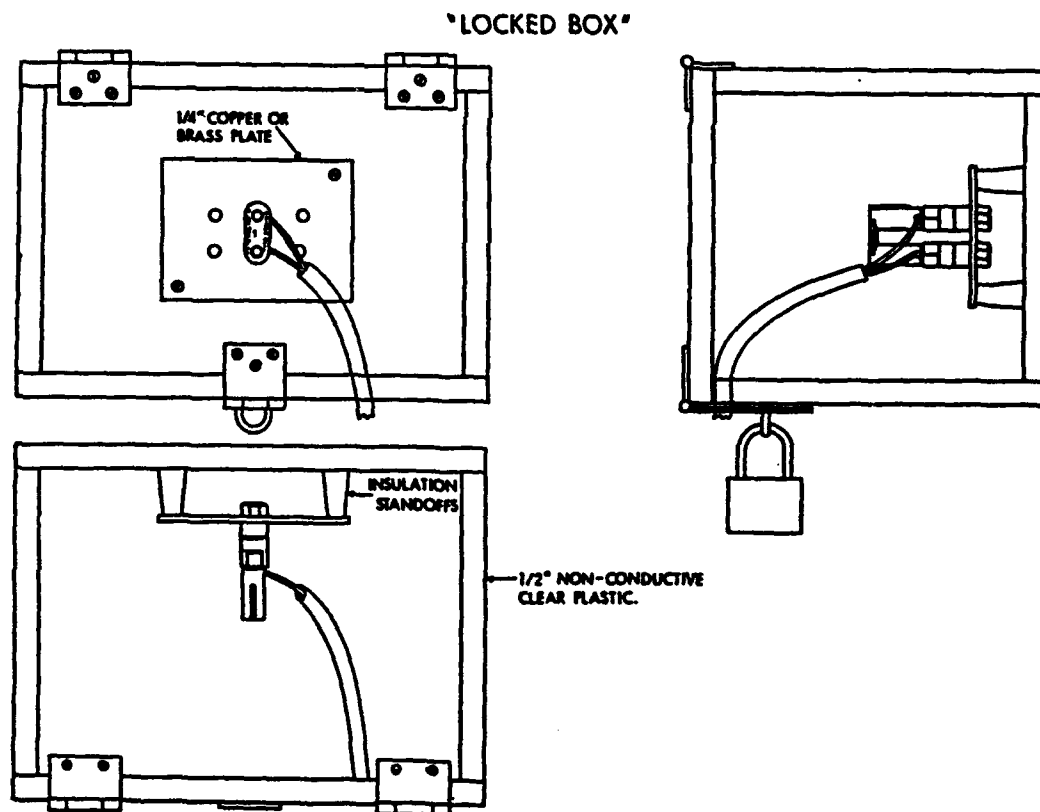
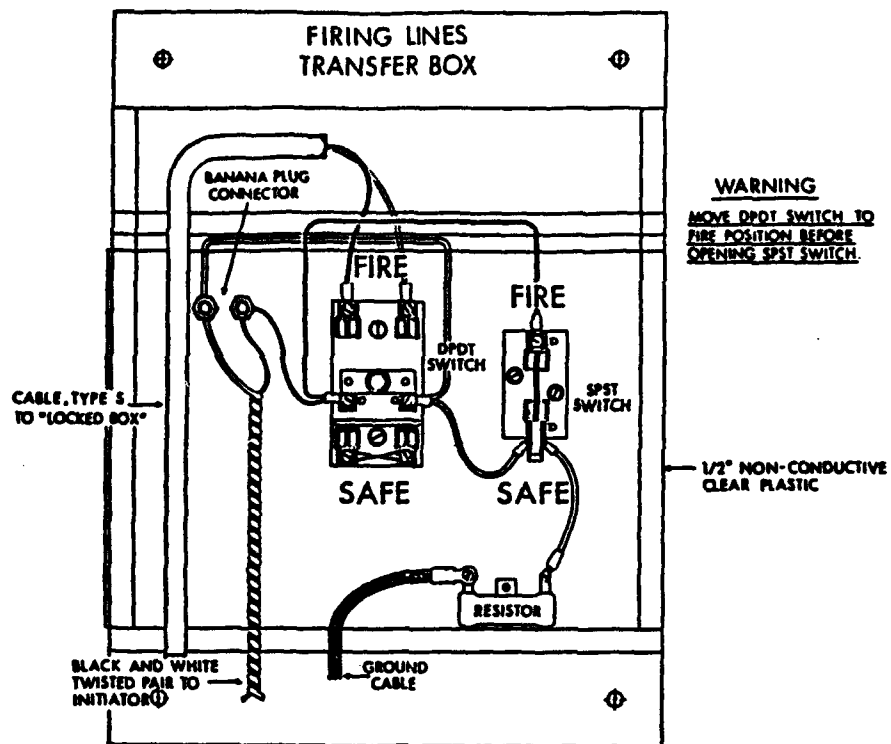

Figure 15. Firing line boxes.

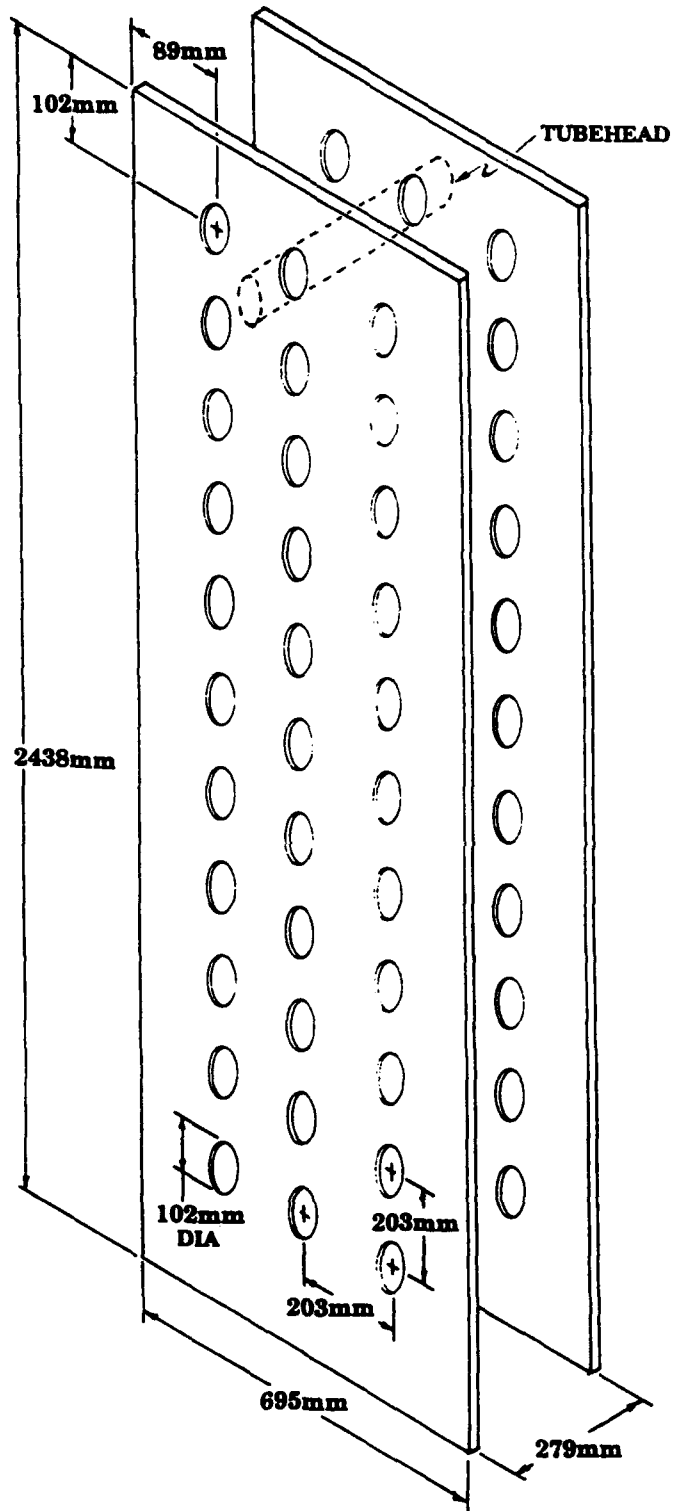

Figure 16. The "Blackburn Wine Rack" technique.

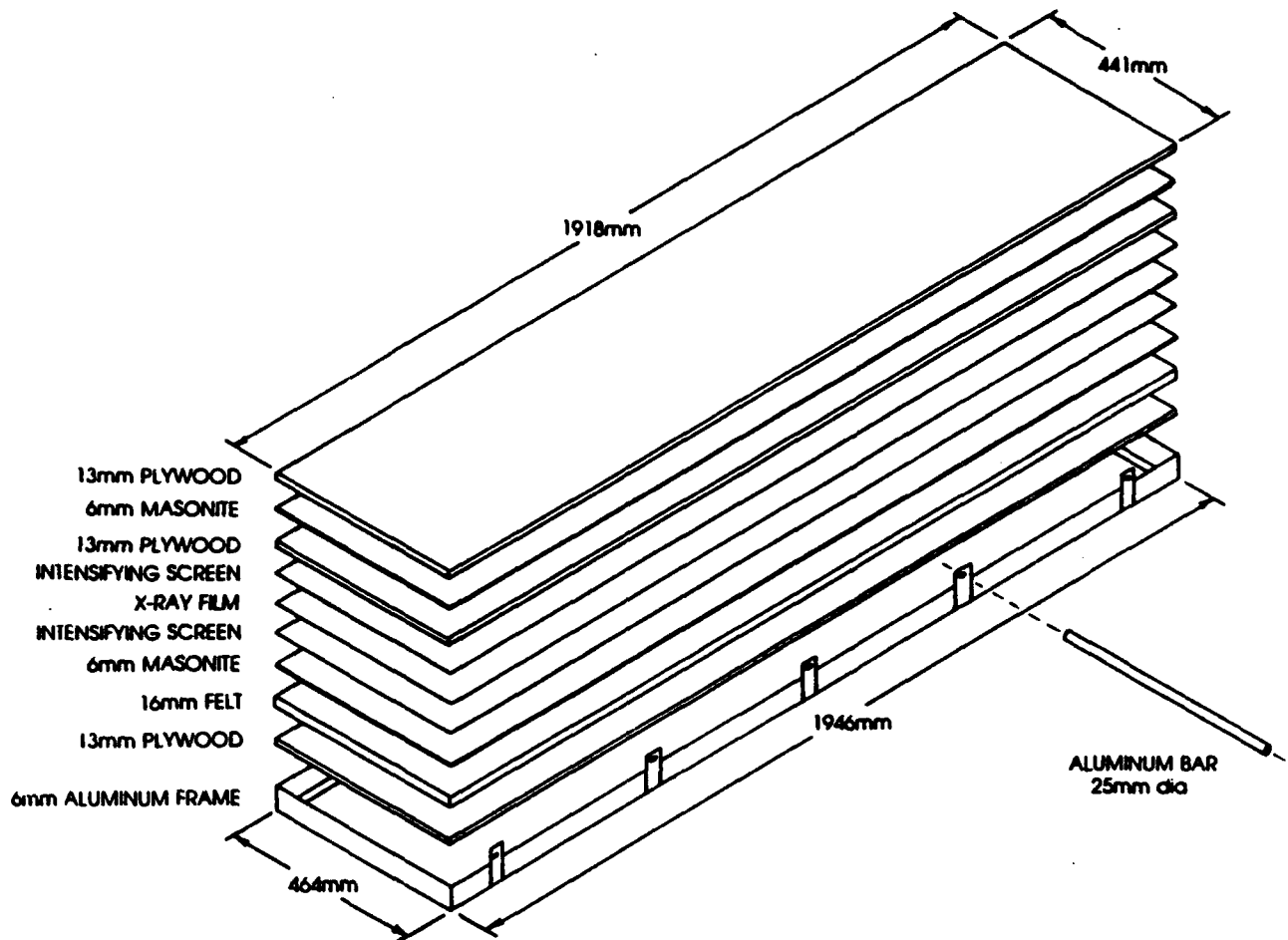

Figure 17. Film cassette.

are needed for adjusting the penetrator's magnification factor on the films. Steel wires (2 mm dia.) are positioned vertically and horizontally inside the cassettes. This produces cross hair lines on the film when exposed from the tube heads' output. These exposed cross hairs show the focal point for each tube head used in that test. These reference points are used in the data reduction. Using long cassettes allows two pre-impact views, target interaction, and two post-impacts of the penetrator at three different time frames (shown in Figure 18). From these sequential images, it is possible to determine many of the penetrator's characteristics.

10892

$V_s = 2785$ m/sec

$V_R = 2461$ m/sec



Pre-impact

456 microseconds

Target interaction

676 microseconds

Post-impact

852 microseconds

Figure 18. Composite of an EFP's pre-impact, target interaction, and post-impact.

6. SUMMARY

The construction and operation of an improved diagnostic test facility at ERF-7A provides increased capability for the studies of EFPs and SC jets. The keyway techniques are beneficial for reducing the amount of welding for constructing such a diagnostic test facility. This technique allows the basic structure to withstand the detonation of larger explosive charges. The "Blackburn Winerack Technique" has increased the facility's turn-around time for flash x-ray tube head alignment and positioning for various warhead studies. The interchangeable port doors make shielding for exposing selected film areas more precise. This newly constructed and operational diagnostic test facility has incorporated many new techniques for present and future armor/antiarmor programs.

<u>No. of Copies</u>	<u>Organization</u>	<u>No. of Copies</u>	<u>Organization</u>
2	Administrator Defense Technical Info Center ATTN: DTIC-DDA Cameron Station Alexandria, VA 22304-6145	1	Commander U.S. Army Missile Command ATTN: AMSMI-RD-CS-R (DOC) Redstone Arsenal, AL 35898-5010
1	Commander U.S. Army Materiel Command ATTN: AMCAM 5001 Eisenhower Ave. Alexandria, VA 22333-0001	1	Commander U.S. Army Tank-Automotive Command ATTN: AMSTA-JSK (Armor Eng. Br.) Warren, MI 48397-5000
1	Director U.S. Army Research Laboratory ATTN: AMSRL-OP-CI-AD, Tech Publishing 2800 Powder Mill Rd. Adelphi, MD 20783-1145	1	Director U.S. Army TRADOC Analysis Command ATTN: ATRC-WSR White Sands Missile Range, NM 88002-5502
1	Director U.S. Army Research Laboratory ATTN: AMSRL-OP-CI-AD, Records Management 2800 Powder Mill Rd. Adelphi, MD 20783-1145	(Class. only) 1	Commandant U.S. Army Infantry School ATTN: ATSH-CD (Security Mgr.) Fort Benning, GA 31905-5660
2	Commander U.S. Army Armament Research, Development, and Engineering Center ATTN: SMCAR-IMI-I Picatinny Arsenal, NJ 07806-5000	(Unclass. only) 1	Commandant U.S. Army Infantry School ATTN: ATSH-WCB-O Fort Benning, GA 31905-5000
2	Commander U.S. Army Armament Research, Development, and Engineering Center ATTN: SMCAR-TDC Picatinny Arsenal, NJ 07806-5000	1	WL/MNOI Eglin AFB, FL 32542-5000
1	Director Benet Weapons Laboratory U.S. Army Armament Research, Development, and Engineering Center ATTN: SMCAR-CCB-TL Watervliet, NY 12189-4050		<u>Aberdeen Proving Ground</u>
1	Director U.S. Army Advanced Systems Research and Analysis Office (ATCOM) ATTN: AMSAT-R-NR, M/S 219-1 Ames Research Center Moffett Field, CA 94035-1000	2	Dir, USAMSAA ATTN: AMXSY-D AMXSY-MP, H. Cohen
		1	Cdr, USATECOM ATTN: AMSTE-TC
		1	Dir, USAERDEC ATTN: SCBRD-RT
		1	Cdr, USACBDCOM ATTN: AMSCB-CII
		1	Dir, USARL ATTN: AMSRL-SL-I
		5	Dir, USARL ATTN: AMSRL-OP-CI-B (Tech Lib)

<u>No. of Copies</u>	<u>Organization</u>
1	Director U.S. Army Armament, Research, Development, and Engineering Center ATTN: SMCAR-FSP-I, P. Burke Picatinny Arsenal, NJ 07806-5000
3	Director U.S. Army Armament, Research, Development, and Engineering Center ATTN: SMCAR-AEE-WE, R. Fong W. Ng J. P. Orosz Picatinny Arsenal, NJ 07806-5000
1	Director U.S. Army Armament, Research, Development, and Engineering Center ATTN: SMCAR-QAT-M, J. Pelino Picatinny Arsenal, NJ 07806-5000
1	Director U.S. Army Armament, Research, Development, and Engineering Center ATTN: SFAE-AR-MCD, R. S. Andrejkovics Picatinny Arsenal, NJ 07806-5000
2	Director U.S. Army Armament, Research, Development, and Engineering Center ATTN: SMCAR-FSM-M, E. Kuriata J. Samtian Picatinny Arsenal, NJ 07806-5000
3	Director U.S. Army Missile Command ATTN: AMSMI-RD-ST-WF, D. Lovelace M. Schexrayder S. Hill Redstone Arsenal, AL 35898-5247

<u>No. of Copies</u>	<u>Organization</u>
	<u>Aberdeen Proving Ground</u>
19	Dir, USARL ATTN: AMSRL-WT-PA, Walter F. Morrison, Jr. AMSRL-WT-TD, Andrew M. Dietrich, Jr. John H. Kineke, Jr. Gary L. Boyce Gat E. Blackburn Mary L. Lake David R. Schall Sterling C. Shelley, Jr. James C. Barb Patsy B. Simmers AMSRL-WT-TA, Thomas A. Havel AMSRL-WT-TB, Robert B. Frey Vincent M. Boyle AMSRL-WT-TC, William S. de Rosset Richard L. Summers Miles L. Lampaon AMSRL-SL-BV, Robert Stinidman AMSRL-SL-BG, Robert G. Gangler Michael W. Enderlein

USER EVALUATION SHEET/CHANGE OF ADDRESS

This Laboratory undertakes a continuing effort to improve the quality of the reports it publishes. Your comments/answers to the items/questions below will aid us in our efforts.

1. ARL Report Number ARL-TR-322 Date of Report December 1993

2. Date Report Received _____

3. Does this report satisfy a need? (Comment on purpose, related project, or other area of interest for which the report will be used.) _____

4. Specifically, how is the report being used? (Information source, design data, procedure, source of ideas, etc.) _____

5. Has the information in this report led to any quantitative savings as far as man-hours or dollars saved, operating costs avoided, or efficiencies achieved, etc? If so, please elaborate. _____

6. General Comments. What do you think should be changed to improve future reports? (Indicate changes to organization, technical content, format, etc.) _____

CURRENT ADDRESS

Organization _____
Name _____
Street or P.O. Box No. _____
City, State, Zip Code _____

7. If indicating a Change of Address or Address Correction, please provide the Current or Correct address above and the Old or Incorrect address below.

OLD ADDRESS

Organization _____
Name _____
Street or P.O. Box No. _____
City, State, Zip Code _____

(Remove this sheet, fold as indicated, tape closed, and mail.)
(DO NOT STAPLE)

DEPARTMENT OF THE ARMY



OFFICIAL BUSINESS

BUSINESS REPLY MAIL
FIRST CLASS PERMIT No 0001, APG, MD

Postage will be paid by addressee.

**NO POSTAGE
NECESSARY
IF MAILED
IN THE
UNITED STATES**

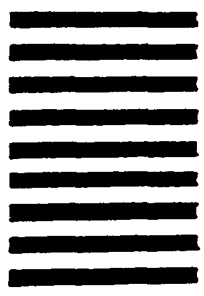

Director
U.S. Army Research Laboratory
ATTN: AMSRL-OP-CI-B (Tech Lib)
Aberdeen Proving Ground, MD 21005-5066
