

2

NASA  
Technical Memorandum 106329

Army Research Laboratory  
Technical Report ARL-TR-237

# Mechanical Systems Technology Branch Research Summary, 1985-1992

Timothy L. Krantz-Editor  
*Vehicle Propulsion Directorate*  
*U.S. Army Research Laboratory*  
*Lewis Research Center*  
*Cleveland, Ohio*

AD-A276 450



DTIC  
ELECTE  
FEB 25 1994

S  
A

September 1993

This document has been approved  
for public release and sale; its  
distribution is unlimited.

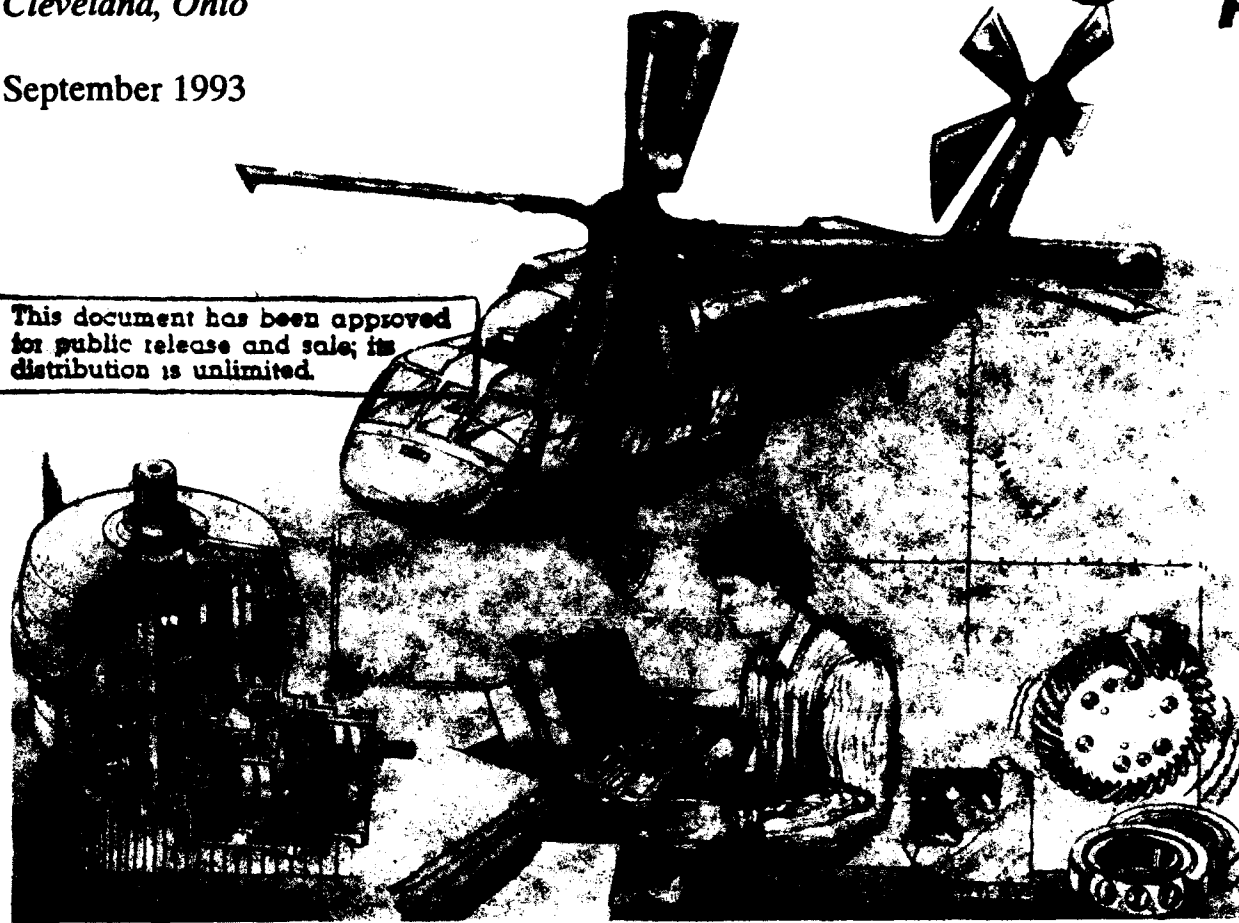

NASA

DTIC QUALITY INSPECTED 2



94-06044



94 2 24 007

## TABLE OF CONTENTS

	Page
Preface .....	1
Design and Evaluation of High Contact Ratio Gearing .....	2
Improved Oil-Off Survivability of Tapered Roller Bearings .....	4
Improved Spur Gears for Aircraft Applications .....	6
Flexibility Effect on Tooth Contact Location in Spiral Bevel Gear Transmission .....	8
Finite Element Analysis of Spiral Bevel Gears .....	10
Computer Numerical Control Grinding of Spiral Bevel Gears .....	12
Spiral Bevel Gears With Conjugate Action .....	14
Low Noise Spiral Bevel Gears .....	16
Spiral Bevel Gear Noise Modeling .....	18
Gear Noise Rig—Facility Design and Installation .....	20
Gear Dynamics Code Validation .....	22
Improved Computer Program for Gear Dynamics .....	24
Analytical Study of Dynamic Load Effect on Gear Pitting Fatigue Life for	
Low-Contact-Ratio Spur Gears .....	26
Computer Program for Life and Reliability of Helicopter Transmissions .....	28
Vibration Characteristics of the OH-58A Helicopter Main Rotor Transmission .....	30
Planetary Gear Train Efficiency Study .....	32
Experimental Results for UH-60 Helicopter Transmission .....	34
Gear Tooth Stress Measurements on UH-60A Helicopter Transmission .....	36
Design and Manufacturing of High-Ratio Self-Aligning Bearingless Planetary	
(SABP) Transmission .....	38
3600 HP Split-Torque Helicopter Transmission .....	40
Advanced Rotorcraft Transmission Program .....	42

	<b>Page</b>
<b>Bell Helicopter Textron Inc.—Advanced Rotorcraft Transmission (ART) Project</b> . . . . .	44
<b>Boeing Helicopters—Advanced Rotorcraft Transmission (ART) Project</b> . . . . .	46
<b>McDonnell Douglas Helicopter Company—Advanced Rotorcraft Transmission (ART) Project</b> . . .	48
<b>Sikorsky Aircraft—Advanced Rotorcraft Transmission (ART) Project</b> . . . . .	50
 <b>BIOGRAPHICAL SKETCHES</b>	
<b>Harold H. Coe</b> . . . . .	52
<b>William G. Costakis</b> . . . . .	53
<b>John J. Coy</b> . . . . .	54
<b>Harry J. Decker</b> . . . . .	55
<b>Robert F. Handschuh</b> . . . . .	56
<b>Katsumi Inoue</b> . . . . .	57
<b>Timothy L. Krantz</b> . . . . .	58
<b>David G. Lewicki</b> . . . . .	59
<b>Fred B. Oswald</b> . . . . .	60
<b>Brian Rebbechi</b> . . . . .	61
<b>Dennis P. Townsend</b> . . . . .	62
<b>Mark J. Valco</b> . . . . .	63
<b>James J. Zakrajsek</b> . . . . .	64
<b>BIBLIOGRAPHY</b> . . . . .	65

**PREFACE**

The research reported herein was performed or managed by the Mechanical Systems Technology Branch of NASA Lewis Research Center. The Branch conducts a joint program in collaboration with the U.S. Army Research Laboratory, Vehicle Propulsion Directorate, which is also located at NASA Lewis. This report summarizes some of our most significant accomplishments from 1985-1992.

Our goal has been to advance aircraft gearing and transmission technology for civil and military aircraft applications by providing technology for lightweight, low noise, highly reliable designs. Most of the work activity to date has been for helicopter gear and transmission technology.

Recently, the Army group at Lewis has broadened its scope to include ground and air vehicle propulsion systems including dual use technologies for high payoff in civil as well as military applications. At the same time, a NASA/Industry study team has identified new requirements for a proposed civil tiltrotor passenger transport aircraft. Hence, it is expected that future work will shift toward advanced tiltrotor air vehicle technology and also include elements of heavy ground vehicle gear technology.

Please review the accomplishments presented in the following pages. If you have comments, questions, or wish to receive any of the referenced reports, you may contact me by phone at (216) 433-3915 or write to me at Mail Stop 77-10, NASA Lewis Research Center, Cleveland, Ohio 44135.

Team work and collaboration amongst the Government, universities, helicopter companies, and other companies such as gear and bearing manufacturers was a strong factor in the successes achieved. Within the branch, work focus teams were formed for each of the following areas: Transmission Analytical Research and Software, Gearbox Noise Reduction, Health and Usage Monitoring, Transmission Systems, and Drive System Components.

I sincerely congratulate everyone whose efforts went into the accomplishments of 1985-1992, including: (1) branch members and visiting scholars (whose biographies appear in this report), (2) Messrs. Dean Reemsynder, William Hady, James Mihalow, Ronald Huff (who are now retired), and (3) our partners in academia and industry (whose names appear as authors of the reports in the bibliography). To all of the aforementioned, I say "thank you for your contributions."

John J. Coy, Ph.D.  
Chief, Mechanical Systems Technology Branch

Accession For	
NTIS CRA&I	↓
DTIC TAB	<input type="checkbox"/>
Unannounced	<input type="checkbox"/>
Justification	
By	
Distribution /	
Availability Codes	
Dist	Avail and/or Special
A-1	

## DESIGN AND EVALUATION OF HIGH CONTACT RATIO GEARING

### Objective

The objective was to improve the surface fatigue life, scoring load capacity, and power-to-weight ratio of helicopter transmission gears by using a high contact ratio gear design.

### Background

A high contact ratio design is one concept for improving the performance of spur gears that has not been fully explored. Standard low contact ratio spur gearing is designed to operate at contact ratios between 1.4 and 1.6, where contact ratio is defined as the average number of tooth pairs in contact as the gears rotate. Thus, a typical contact ratio of 1.5 means that two tooth pairs are in contact half the time and only one tooth pair is in contact the other half. High contact ratio gearing (HCRG) is defined as having at least two tooth pairs in contact at all times, i.e., contact ratios of 2.0 or more. Because the transmitted load is shared by at least two pairs of teeth, the individual tooth loading is less for HCRG than for low contact ratio designs, thereby enabling a higher power-to-weight ratio. HCRG, however requires gear teeth with lower pressure angles, finer pitches, or increased working depths; all of which tend to increase the tooth bending stress. In addition, it is expected that HCRG is more sensitive to tooth spacing errors and profile modifications because of the simultaneous tooth contacts. The basic problem to be resolved was whether the lower tooth loads occurring in the high contact ratio design configuration more than offset the effects of the weakened tooth form, especially when run under dynamic load conditions.

### Approach

A contract was established to design and experimentally test high contact ratio gears in comparison with low contact ratio gears. Designs were analyzed using computer program GRDYN (Gear Dynamic Analysis) to simulate gear dynamic behavior.

### Results

A design analysis of standard and high contact ratio gears was performed using computer program GRDYN. Results of the gear dynamic simulation study enabled the selection of an optimum tooth profile for minimum dynamic load. The optimum was achieved with a quadratic tooth profile modification, beginning at 90 percent of the tooth addendum and ending with the maximum modification at the tip of the tooth.

Fourteen standard and fourteen high contact ratio gears were fabricated and tested in a four-square (power recirculating) test rig to determine the relative fatigue lives. The failure distributions of the gears was established for a specific load of 6667 lb/in. of tooth face-width. The HCRG had two times the fatigue life of standard gears at the 10 percent failure point.

The load capacity for resistance to scuffing/scoring was also determined. The HCR gears carried 5600 lb/in. with a 50 percent scuffing/scoring occurrence, which is slightly better than the 4500 lb/in. carried by standard gears.

During the study it was found that computer program GRDYN was essential to establishing a viable design of the high contact ratio gear. The reason was that high contact ratio gears are very sensitive to the effects of tooth profile modifications on the load sharing and resultant dynamic loads. Further details are reported in NASA CR-174958, "Design and Evaluation of High Contact Ratio Gearing" by Frint.

### Significance

Gear life can be significantly extended by using high contact ratio gears instead of standard gears. High contact ratio gears have slightly better load capacity compared to standard gears, when the mode of failure is scoring (scuffing). Therefore, high contact ratio gears can significantly increase life, reliability, and power-to-weight ratio for helicopter transmissions.

## HIGH CONTACT RATIO GEARING - DESIGN AND EVALUATION



HIGH CONTACT RATIO GEAR

STANDARD GEAR

### **MILESTONES ACHIEVED:**

- COMPLETED DESIGN AND ANALYSIS
- COMPLETED FATIGUE AND LOAD CAPACITY EXPERIMENTS
- DEFINED OPTIMUM TOOTH SHAPE USING COMPUTER SIMULATION
- NASA CR 174958 PUBLISHED

### **SIGNIFICANCE:**

- HIGH CONTACT RATIO GEARS HAVE TWICE THE LIFE OF STANDARD GEARS
- HIGHER LOAD CAPACITY
- INCREASED LIFE, RELIABILITY, AND POWER-TO-WEIGHT RATIO FOR HELICOPTER DRIVE SYSTEMS

Figure 1.—Design and evaluation of high contact ratio gearing.

# IMPROVED OIL-OFF SURVIVABILITY OF TAPERED ROLLER BEARINGS

## Objective

The objective was to develop a bearing design capable of operating for 30 min after loss of oil.

## Background

Design studies of helicopter transmissions have shown that the use of tapered roller bearings on the input shaft can result in a lighter, more reliable transmission. However, the contact of the ends of the tapered rollers with the guide flange is very sensitive to proper lubrication. Therefore, the loss of oil at the conjunction can quickly lead to complete bearing failure. What was needed then was a method of providing adequate lubrication at the roller-flange interface so that the bearing could operate for at least 30 min after loss of the main oil supply.

## Approach

An oil-impregnated powder metal ring was used for a rib (flange) with either a cup or cone design. Three materials identified in screening tests were used: M2 tool steel at 65 percent density and CBS 1000M steel at 65 and 75 percent density.

## Results

- Oil-off testing is complete.
- Standard design bearing ran only 10 min at 4000 rpm.
- Survivable design, ribbed cup bearings ran for 30 min at 11 000 rpm.
- The bearings operated for less than 5 min at 17 000 rpm.
- Technical report published (CR-180804, AVSCOM TR-87-C-29), "Improved Oil-Off Survivability of Tapered Roller Bearings" by Kreider and Lee.

## Significance

Improved design extends oil-off operation of tapered roller bearings to over 30 min at 11 000 rpm (0.7 million DN) at typical helicopter transmission loads, thus permitting consideration of tapered roller bearings for helicopter transmission applications.

## IMPROVED OIL-OFF SURVIVABILITY OF TAPERED ROLLER BEARINGS

### MILESTONE ACHIEVED:

LABORATORY TESTS DEMONSTRATED OIL-OFF SURVIVABILITY OF TAPERED ROLLER BEARINGS TO OVER 30 MINUTES AT 11 000 RPM.

- STANDARD DESIGN RAN ONLY 16 MINUTES AT 4000 RPM.
- POWDERED METAL M-2 AND CBS 1000M STEEL AT 65 AND 75% DENSITY USED FOR RIB RINGS.
- NASA CR-180804  
AVSCOM TR-87-C-29

### SIGNIFICANCE:

TAPERED ROLLER BEARINGS CAN NOW BE CONSIDERED FOR USE IN ADVANCED DESIGN HELICOPTER TRANSMISSIONS TO REDUCE WEIGHT AND INCREASE LIFE.

Figure 2.—Improved oil-off survivability of tapered roller bearings.

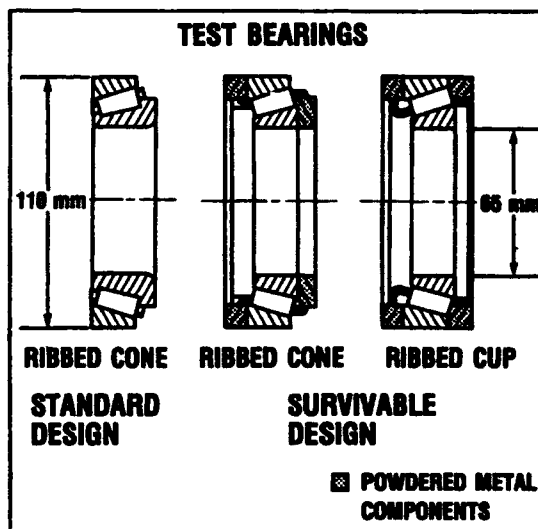

# IMPROVED SPUR GEARS FOR AIRCRAFT APPLICATIONS

## Objective

The objective was to reduce noise and vibration in spur gear drives by designing the gear teeth to be tolerant of misalignments of the shaft axes.

## Background

Spur gears are widely used in aircraft to transmit mechanical power between drive shafts with parallel axes. Light weight is essential in aircraft applications, but lightweight gear boxes are prone to deflect when loaded, which is a disadvantage. So in the design of an aircraft gearbox there is a tradeoff between weight and structural rigidity. If emphasis is put on light weight, then under flight conditions the gear shafts can deflect and become misaligned. When the shafts are misaligned, the load between the mating gears is no longer carried in the ideal way, that is, uniformly distributed across the face of the gear teeth. Instead, the load can become concentrated to one edge of the teeth. If this happens, the gears become noisy and soon wear out.

Current practice is to eliminate edge loading by putting a slight crown on the teeth during the grinding process. The crowning will prevent the load from moving to the edge of the tooth, but the gears are still noisy when misaligned. This is because the conventionally crowned gears do not transmit motion smoothly.

A new crowning technique was needed that would not only continue to avoid edge loading but also reduce the vibration and noise when the gears have to operate with misaligned shaft axes.

## Approach

A grant was established at the University of Illinois at Chicago (Dr. Faydor L. Litvin, principal investigator). The mathematical principles of gear meshing were applied to find the type of gear tooth crowning that is least sensitive to misalignments.

## Results

A new concept for crowning spur gear teeth has been discovered. The concept is supported by the rigorous application of the mathematics of tooth meshing theory. The analysis has been coded into a computer program for tooth contact analysis, which calculates the tooth load distribution and the motion errors which cause vibration and noise. The computer program enables one to select the best crowning geometry that will compensate for a range of misalignment.

The crowning can be produced by either of two methods of grinding: (1) using a five-axis numerically controlled machine with a flat grinding wheel or (2) using a conventional gear grinding machine with a grinding wheel that is basically cone-shaped but with a slight curvature to the cone element.

The complete results of the investigation are reported in NASA CR-4135 (AVSCOM TR 88-C-002), "Spur Gears: Optimal Geometry, Methods for Generation and Tooth Contact Analysis (TCA) Program" by Litvin and Zhang.

### Significance

The new crowning technique benefits aircraft applications where light weight is important. The crowning compensates for misaligned conditions of the shaft axes and is minimally sensitive to variation in misalignment. Smoother motion is transmitted between shafts. The benefit is less noise and vibration while maintaining light weight and long life.

## IMPROVED SPUR GEARS FOR AIRCRAFT APPLICATIONS

### MILESTONES:

- NEW CROWNING THEORY DISCOVERED
- ANALYTICAL MODEL DEVELOPED
- COMPUTER CODES COMPLETED
- NEW MANUFACTURING METHOD DESCRIBED
- NASA CR-4135

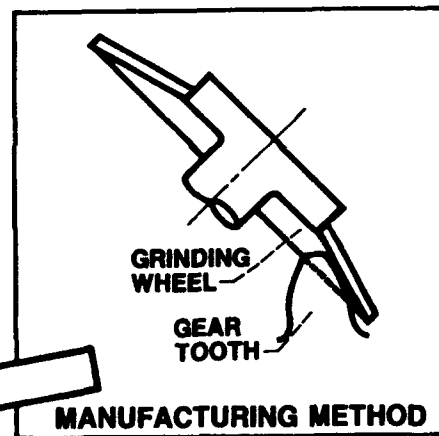
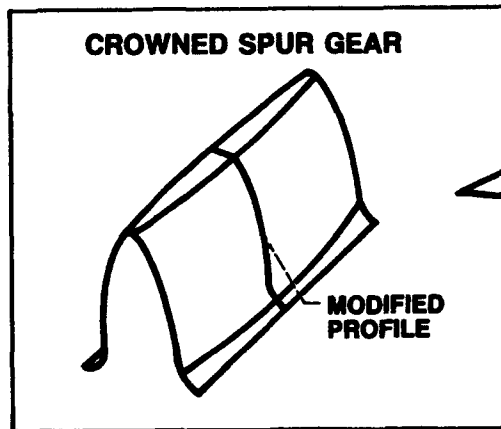

### SIGNIFICANCE:

- SMOOTHER TRANSMITTED MOTION
- LESS NOISE AND VIBRATION
- MINIMUM SENSITIVITY TO MISALIGNMENTS

Figure 3.—Improved spur gears for aircraft applications.

# **FLEXIBILITY EFFECT ON TOOTH CONTACT LOCATION IN SPIRAL BEVEL GEAR TRANSMISSION**

## **Objective**

The objective was to include the effect of gear shaft and bearing deflections in the tooth contact analysis of spiral bevel gears.

## **Background**

Spiral bevel gears are used in helicopter transmissions to transfer power between nonparallel, intersecting shafts. In helicopter applications, designers strive for high power-to-weight ratios for mechanical components. Components have become lighter and are subjected to higher loads. Thus, the helicopter transmissions are becoming more flexible with higher deflections.

In practice gears are manufactured and inspected, and the actual tooth contact patterns are compared to the predicted ones. The actual pattern might be quite different than predicted since predicted patterns do not include component deflection effects. Contact may go to the edge of the tooth, causing high stress and short life. A trial-and-error process to correct the tooth contact is a long, expensive process. A need was perceived to investigate the effect of gear shaft and bearing deflections on spiral bevel tooth contact.

## **Approach**

A university research grant was established to develop a simplified spiral bevel gear tooth contact analysis computer program to include component deflection effects.

## **Results**

A tooth contact analysis computer program was developed for spiral bevel gears. The program models a single bevel gear mesh along with the support bearings. Gear and bearing geometry, mountings, and operating conditions are inputted to the program. Program output includes a gear loading analysis, gear shaft and bearing deflections, tooth contact results, and the effect of gear shaft and bearing deflections on the tooth contact. A description of the analysis and the computer program listing is available in NASA CR-4055, "Flexibility Effects on Tooth Contact Location in Spiral Bevel Gear Transmissions" by Altidus and Savage.

## **Significance**

The computer program developed in this work can predict the shift of the contact position for spiral bevel gear teeth due to gear shaft and bearing flexibility effects. Adverse effects on gear performance and life due to detrimental shifts of tooth contact positions can be avoided. Also, improved analytical methods reduce the amount of expensive testing that is required for a safe gear design.

## **FLEXIBILITY EFFECTS ON TOOTH CONTACT LOCATION IN SPIRAL BEVEL GEAR TRANSMISSIONS**

### **MILESTONES ACHIEVED:**

SPIRAL BEVEL GEAR TOOTH CONTACT  
ANALYSIS COMPUTER PROGRAM DEVELOPED:

- SHAFT & BEARING FLEXIBILITY  
EFFECTS INCLUDED
- TOOTH CONTACT SHIFT DUE TO  
FLEXIBILITY EFFECTS PREDICTED
- NASA CR PUBLISHED

### **SPIRAL BEVEL GEAR MESH**



### **GEAR TOOTH**

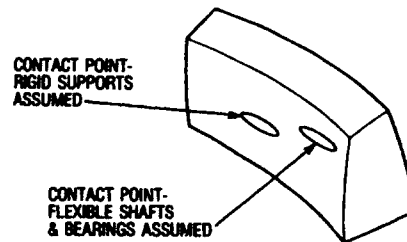

### **SIGNIFICANCE:**

- DETRIMENTAL GEAR TOOTH CONTACT  
LOCATIONS CAN BE AVOIDED
- GEAR PERFORMANCE & LIFE CAN BE  
INCREASED
- AMOUNT OF EXPERIMENTAL TESTING  
CAN BE REDUCED

Figure 4.—Flexibility effects on tooth contact location.

# FINITE ELEMENT ANALYSIS OF SPIRAL BEVEL GEARS

## Objective

The first objective was to develop a computer code for calculating the true surface coordinates of bevel gear teeth based on the manufacturing conditions. The second objective was to demonstrate the new code's use in conjunction with modern finite element analysis tools.

## Background

Spiral bevel gears are used in helicopters to transfer power from the horizontal axis engines to the vertical axis main rotor shaft. Fast, accurate finite element analysis methods are needed to improve the power transfer and minimize the weight for helicopter drive systems.

In the 1970's the finite element method was firmly established as a standard structural analysis tool. In the 1980's the process was greatly improved through the use of pre- and post-processor programs where finite element meshes and boundary conditions are displayed prior to the analysis and the stress/displacement results are displayed after the analysis. Now, the result of thousands of finite element calculations for a complex structure can be displayed in just a few color plots.

This technique has been successfully applied to parallel axis gears. However, because spiral bevel gear geometry is so complicated, until now only approximations of the tooth surface could be used in the analysis.

## Approach

The well-known involute function provides a closed-form equation that can be used to solve for the tooth surface coordinates of spur gears. However there is no closed form equation for the tooth surface coordinates of spiral bevel gears. Therefore, the manufacturing process has to be numerically simulated with a set of simultaneous nonlinear algebraic equations. This is enabled by the gear geometry theory developed by Litvin at the University of Illinois at Chicago. Once the tooth surface coordinates are determined, computer programs PATRAN and MSC/NASTRAN can be used for the structural analysis.

## Results

The computer program SURFACE has been written. Inputs to the program are the manufacturing machine tool settings and the basic gear design variables. The output is the set of coordinates forming a surface grid for both side of the gear tooth. This grid is input to the modeling program PATRAN permitting a one-tooth model to be produced. Within PATRAN the desired number of teeth can be generated and the applied load and boundary conditions defined. PATRAN then provides input to MSC/NASTRAN for the structural analysis for the spiral bevel gears. The major principle stresses are calculated by MSC/NASTRAN and displayed by PATRAN. The complete results are reported in NASA TP-3096 (AVSCOM TR 91-C-020), "A Method for Determining Spiral Bevel Tooth Geometry for Finite Element Analysis" by Handschuh and Litvin.

### Significance

Computer program SURFACE permits rapid, accurate model development for finite element analysis of spiral bevel gears. This will enable the design of lighter, more reliable gears for rotorcraft applications.

## Finite Element Analysis of Spiral Bevel Gears

### Milestones completed:

- Analysis completed
- Code written
- NASA TP & AVSCOM TR

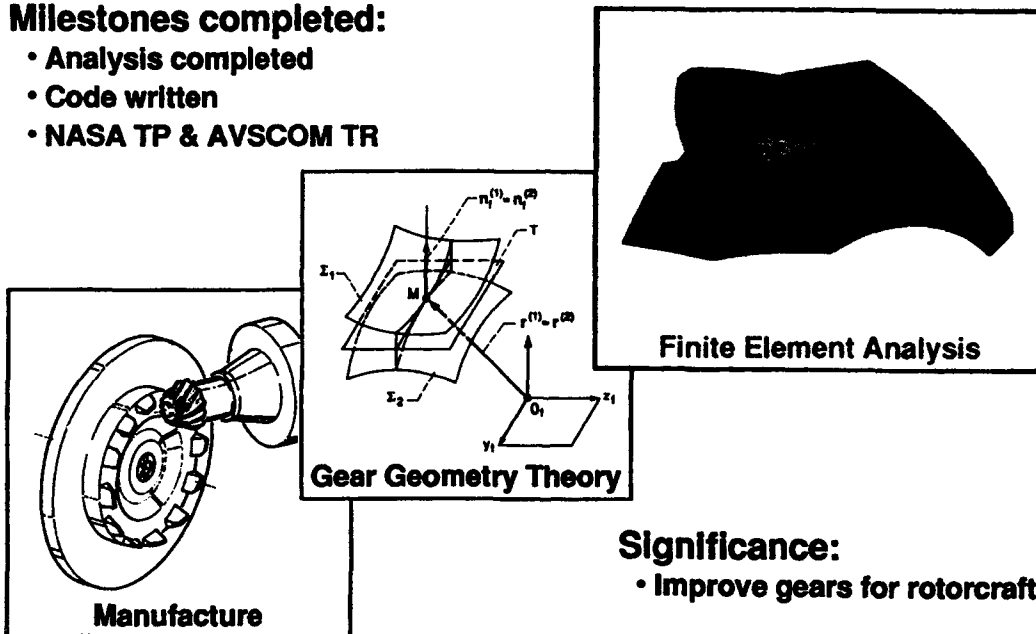

### Significance:

- Improve gears for rotorcraft

Figure 5.—Finite element analysis of spiral bevel gears.

# COMPUTER NUMERICAL CONTROL GRINDING OF SPIRAL BEVEL GEARS

## Objective

The objective was to develop a grinding process for spiral bevel gears that would lower component costs by (1) reducing the time required for machine setup and maintenance of the setup by 50 percent and (2) improving the machine repeatability.

## Background

The aerospace gear manufacturing community is typically faced with many problems when producing aircraft quality spiral bevel gears. First of all, current manufacturing machinery for spiral bevel gear grinding requires manual adjustment for all process variables. Long setup times are common when changing the machine over to manufacture a different gear. Also, due to the extremely tight tolerances on the manufactured components, machine adjustments are necessary after every few parts to keep the finished product within tolerance. These adjustments require the continuous attendance of a highly skilled operator. Another problem peculiar to the aerospace gearing community is the small number of components, typically 20 gears or less, that are in a given production run. In small runs, the setup costs have a large influence on the total cost of each part.

During the manufacture of a spiral bevel gear, many items are constantly monitored. These gears must have: (1) a minimal amount of stock removal to ensure that hardened surfaces are not machined away, (2) proper tooth contact patterns as determined by roll testing against flight qualified master gears, and (3) a very good surface finish. Failure of any of these important criteria will scrap the part. This can be very expensive because a great deal of material, manufacturing time, and manpower have already been invested in a given component before the final grinding operation is performed.

The U.S. Army AVSCOM determined it would be in their best interest to improve the state of the art in spiral bevel gear grinding through their Manufacturing Methods and Technology (MM&T) activity. The objective of the project was to convert a manual controlled Gleason Gear Grinder to a computer numerical controlled (CNC) grinder.

## Approach

A contract (NAS3-25030) was obtained with Bell Helicopter Textron Inc. The Gleason Works was a major subcontractor with responsibility for the design, building, and acceptance testing of the prototype machine. Bell Helicopter then tested the prototype machine in a production environment.

The program was completed in three phases: Phase I involved the design of the prototype CNC grinder based on the model 463 Gleason manual grinder. A large number of the manual setup variables were eliminated. Where manual settings were still required, electronic positioning systems were used to prevent operator errors. A CNC controller was added to monitor and control the manufacturing process. Phase II entailed taking a U.S. Army owned manual grinder, having it rebuilt, and adding the CNC machine improvements. Phase III was for production testing of the prototype machine. The machine was sent to Bell Helicopter and installed in their gear production plant in Fort Worth, Texas. The machine was used to support their production requirements and conduct tests on a

wide size range of gears. Improvement of the spiral bevel gear grinding process due to the addition of CNC was then measured through time-study of machine setup and production.

### Results

Two major machine improvements were made. A CNC dresser system was added to accurately control grinding wheel shape. Also, the drive system that controls the motion between the cradle and work piece was radically altered. On the manual machine this motion was controlled through a cam, shafts, and gears. The new design eliminated many of these. The drive system now has a minimum of gear sets and position is controlled via optical encoders. Also, software for CNC control of machine processes and spiral bevel gear manufacturing methodologies was developed. A series of nine tests were used to assess the improvements due to the addition of CNC. Over the nine tests the average savings on setup and maintenance of setup time was 65 percent. This means reducing the setup time that currently takes over 32 hr down to just over 11 hr. The average savings in grind cycle time (time spent grinding) was 34 percent. This savings demonstrates increased material removal rate which was made possible by a stiffer grinding wheel support structure. Further details are reported in NASA CR-187175 (AVSCOM TR 90-F-6), "Computer Numerical Control Grinding of Spiral Bevel Gears" by Scott.

### Significance

CNC conversion of existing manual machines can provide many benefits to the aerospace gear manufacturing community. Many of the process variables are now easier to control. Resetting of the machine for a new job has a much lower time to production. All are benefits in reducing production costs for aerospace spiral bevel gears.

## COMPUTER NUMERICAL CONTROL (CNC) GRINDING OF SPIRAL BEVEL GEARS

### MILESTONES COMPLETED:

- PROTOTYPE DESIGNED
- PROTOTYPE GRINDER BUILT
- PRODUCTION GRINDING TESTS COMPLETED



### BENEFITS:

- REDUCED SETUP TIME
- REDUCED GRIND TIME
- REDUCED SCRAP

**SIGNIFICANCE: REDUCED COST**

Figure 6.—Computer numerical control (CNC) grinding of spiral bevel gears.

# SPIRAL BEVEL GEARS WITH CONJUGATE ACTION

## Objective

The objective was to develop and analyze a new method for generation of spiral bevel gears that have lower noise.

## Background

Noise generated by gears is due to a number of different mechanisms. One of the most significant mechanisms is kinematic error. Elimination of kinematic errors in helicopter gears should noticeably reduce noise and vibration.

Kinematic errors are defined as the deviations from a constant rate of turning of the driven gear while the driving gear turns at a constant rate. If a set of gears transmits motion without kinematic errors, then they are said to have conjugate motion. It is this varying gear ratio that provides a source of vibration (noise) excitation to the gear system.

Conjugate motion results if the vector normal to the gear tooth surfaces at the point of contact passes through the pitch point during the process of meshing. This requirement is satisfied for spur gears of involute tooth profile. The involute system of tooth shapes can be described by simple mathematical expressions. In contrast to spur gears, there is no equation for describing the surface of a spiral bevel gear tooth. The surface coordinates of the points on the tooth must be numerically determined, based on synthesis of the gear manufacturing process.

## Approach

A grant was funded for development of analytical models and computer programs at the University of Illinois at Chicago, and that work was supplemented by an in-house computer visualization and experimental effort.

## Results

The concept of conjugate motion as described for spur gears has been extended to spiral bevel gears. A way of visualizing how the meshing of spiral bevel gears with conjugate motion can take place is by examining the meshing process for spur gears. For spur gears the surface normal at the contact point always passes through a fixed point in space—the pitch point. For the bevel gears, which can be imagined as two pitch cones rolling against one another at a pitch line, the normal to the tooth surfaces at the contact point must pass through a fixed line in space—the pitch line. If this condition can be maintained during meshing, conjugate motion of spiral bevel gears will be achieved.

The numerical analysis is contained in two computer programs. The first determines the machine tool settings for the conjugate spiral bevel gears. The second program determines the tooth contact between the meshing gear teeth for one pitch of pinion rotation. Details of the analysis are contained in NASA CR-4088, "Generation of Spiral Bevel Gears with Conjugate Tooth Surfaces and Tooth Contact Analysis" by Litvin, Tsung, and Lee.

### Significance

Conjugate spiral bevel gears can be manufactured using existing equipment by application of the developed analytical tools to determine the proper surface generating machine tool settings.

## SPIRAL BEVEL GEARS WITH CONJUGATE ACTION

### MILESTONES COMPLETED:

- CONJUGATE GEAR CONCEPT
- ANALYTICAL MODEL DEVELOPED
- COMPUTER CODES COMPLETED
- NASA CR-4088

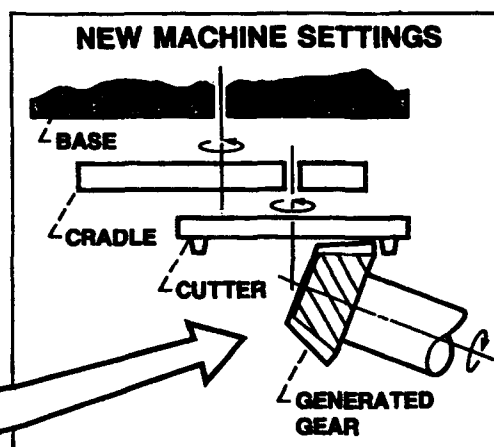
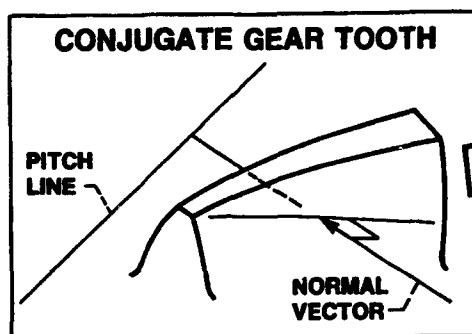

### SIGNIFICANCE:

- REDUCED NOISE AND VIBRATION
- EXISTING GEAR MANUFACTURING MACHINES CAN BE USED

Figure 7.—Spiral bevel gears with conjugate action.

## LOW NOISE SPIRAL BEVEL GEARS

### Objective

The objective was to identify a method of manufacture for spiral bevel gears using existing U.S. made machine tools that will produce gears with lower noise characteristics and increased life.

### Background

The spiral bevel gear is used to transmit power between intersecting shafts. Spiral bevel gears as used in aviation applications must run at high speed and carry high loads. The most important application in aviation systems is in helicopter transmissions. Spiral bevel gears are manufactured on special gear generator machines made by the U.S. Company, Gleason. There are competing foreign-built machines, but Gleason machines have the advantage of high rigidity and accuracy. Furthermore, the Gleason machines allow the cutting wheel speed to be selected independently from the generating motions of the machine. This means that milling and grinding are possible.

A disadvantage has been that Gleason-cut gears do not run as quietly as gears made on foreign-built gear generating machines. The foreign-built machines use a different generating motion that produces smoother running gears. In technical terms, these gears have conjugate action, which is to say there is no kinematic error.

The kinematic error in operating gears causes high vibration and noise. A typical vibration spectrum taken from a helicopter transmission test at NASA Lewis Research Center is shown. The spiral bevel gear mesh produces the highest level of vibration when compared to the other meshing frequencies. As well as causing noise, high vibration levels shorten transmission life. Therefore, it would be beneficial to reduce the spiral bevel gear vibration, with the net result being a quieter operating transmission having longer life.

Thus the objective of the program was to reduce the kinematic errors, which will give lower noise and longer life.

### Approach

The approach used to conduct this project has been to develop computer algorithms. These computer codes simulate gear generation, calculate pinion and gear meshing, and determine improved gear generation machine settings. A three-dimensional graphics program is being developed for tooth contact visualization. Verification of the methods developed will be done by building and testing spiral bevel gears.

### Results

A computer code is now operational on a mainframe computer for a right-handed pinion and left-handed gear. This code has been applied to a spiral bevel gear set to be manufactured on Gleason equipment. The analytical results indicate a greatly reduced kinematic error. Efforts are currently being made to extend the analysis to left-handed pinion and right-handed gear sets and for development of three-dimensional graphics for tooth contact visualization.

## Significance

The benefits are that existing U.S. made equipment can now be used to manufacture superior spiral bevel gears. These gears will have low kinematic error which gives low noise and increased life.

### LOW NOISE FOR BEVEL GEARS

**MILESTONE ACHIEVED:  
NEW PROCESS FOR MANUFACTURE  
OF QUIET RUNNING SPIRAL BEVEL GEARS**

- BEVEL GEARS ARE BIGGEST SOURCE OF NOISE IN CURRENT HELICOPTERS
- NOISE SOURCE IN KINEMATIC ERRORS
- KINEMATIC ERRORS HAVE BEEN REDUCED TO ZERO

**SIGNIFICANCE:  
LONGER LIFE AND LOWER NOISE**

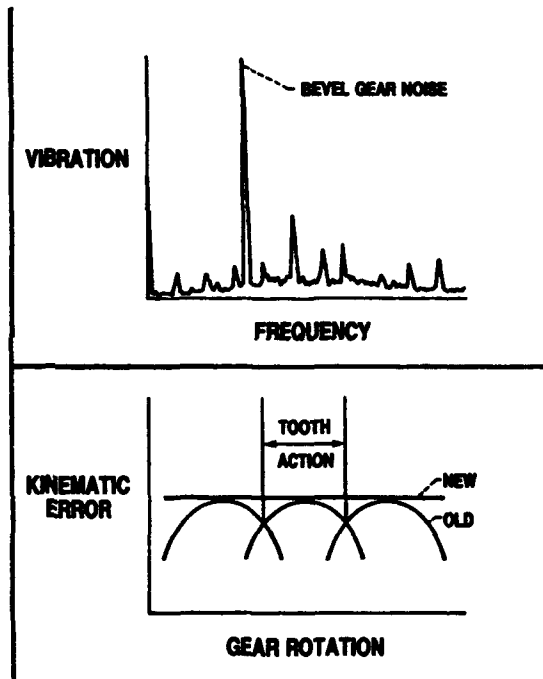

Figure 8.—Low noise for bevel gears.

## **SPIRAL BEVEL GEAR NOISE MODELING**

### **Objective**

The objective was to develop a noise prediction model for spiral bevel gears.

### **Background**

Spiral bevel gears are used in helicopters to transmit power "around the corner" from a horizontal engine output shaft to the vertical rotor shaft.

Vibration from spiral bevel gears dominates the vibration signature of a transmission. The vibration from spiral bevel gears is caused by transmission errors, which are defined as the deviations in angular velocity ratio between the driving and driven gear.

For parallel axis (spur and helical) gears the transmission error has been defined assuming that gear shafts remain parallel. Since shafts of bevel gears are not parallel, there was a need to generalize the concept of transmission errors to three dimensions in order to understand their physical causes and predict the effect on vibration and gear noise. The goal was to relate dynamic loading and gear noise to physical factors such as deviations of tooth surfaces and gear shaft centerlines from their ideal positions; tooth and gear body stiffness; bearing and housing support flexibility; and input shaft torque.

### **Approach**

NASA Lewis contracted with BBN Laboratories, Inc., to perform an analytical study.

The mathematical model of spiral bevel gears assumes small deviations from the spherical involute tooth form. For such gears, tooth contact takes place within the base disk located in the base plane. The generalized transmission error is described in terms of the three-component (one rotation and two translations) deviations of real gears from their idealized spherical involute counterparts.

### **Results**

The mathematical analysis was completed and is reported in NASA CR-4081, "Analysis of the Vibratory Excitation Arising from Spiral Bevel Gears" by Mark. Equations have been developed for computing the zone of tooth contact, the three components for the generalized transmission error and spectral content of transmission error as a function of measurable gear parameters. The expressions for the generalized transmission errors combined with equations for mesh force and mesh elasticity yields a 6 degree of freedom equation of constraint. This constraint equation is to be combined with the equations of motion of gear systems to generate matrix equations which may be solved to predict the vibration and noise of the system.

## Significance

This work provides the first detailed mathematical understanding of generalized transmission error in spiral bevel gears. The spectral components of vibration excitation based on gear measurement data can be predicted. By relating gear noise to physical design parameters, a basis is provided for future improvements in spiral bevel gear design.

## **SPIRAL BEVEL GEAR NOISE MODELING**

### **MILESTONES COMPLETED:**

- **MATHEMATICAL MODEL OF ZONE OF TOOTH CONTACT FOR SPIRAL BEVEL GEARS**
- **NEW UNDERSTANDING OF 3-DIMENSIONAL NATURE OF TOOTH MESHING**
- **TIME AND FREQUENCY DOMAIN ANALYSIS FOR NOISE EXCITATION FUNCTION**
- **NASA CR 4081**

### **SIGNIFICANCE:**

- **ALLOWS PREDICTION OF VIBRATION FROM GEAR MEASUREMENTS**
- **PROVIDES BASIS FOR FUTURE IMPROVEMENTS IN SPIRAL BEVEL GEAR DESIGN**

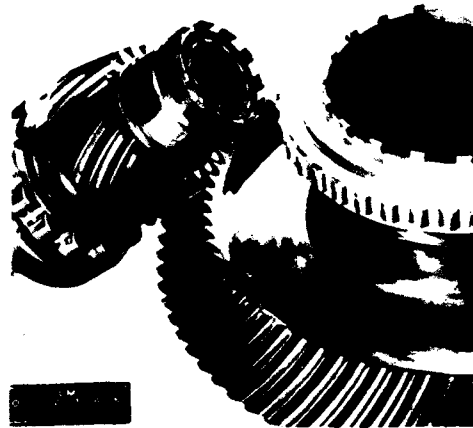

Figure 9.—Spiral bevel gear noise modeling.

## **GEAR NOISE RIG—FACILITY DESIGN AND INSTALLATION**

### **Objective**

The objective was to establish an experimental test facility to support helicopter transmission noise reduction research.

### **Background**

In a helicopter, the geared transmission is a very efficient device for converting the high-speed, low-torque power output of the gas turbine engine to the low-speed, high-torque power required to drive the rotor blades. Unfortunately, transmission gear noise (which has been measured at over 100 dB sound power) is the major source of noise in a helicopter cabin. This noise causes adverse health effects and disrupts communication. The helicopter transmission noise reduction research project was initiated to solve this problem.

Gear vibration and noise have been simulated by computer codes, but there was an acute need to validate these codes with experimental data taken under carefully controlled conditions. There was also a need for an experimental facility to help identify and develop advanced concepts for helicopter transmission noise reduction. The gear noise rig was built to satisfy these needs.

### **Approach**

The preliminary transmission design was analyzed in-house using existing gear dynamics computer programs. The test facility requirements were selected on the basis of the analysis. The facility and test transmission final design were done under contract and the hardware was fabricated and assembled in-house.

### **Results**

The Gear Noise Reduction Research Team accomplished the design, analysis, fabrication and installation of the NASA Gear Noise Test Facility. The safety committee approved the facility and operating plan. The facility has been in use since 1989 to collect data on gearbox dynamics and gearbox noise.

### **Test Rig Capability**

A 200-hp variable-speed motor powers the rig from one end and an eddy-current dynamometer applies power-absorbing torque at the other end. The test gearbox is driven at speeds up to 10 000 rpm. The dynamometer maximum speed is 6000 rpm. The maximum power that can be absorbed by the dynamometer is 175 hp. The gearbox can test spur or helical gears of various ratios. The center distance between the input shaft and output shaft is adjustable from 90 to 135 mm (3.5 to 5.25 in.). Space exists for optional flywheels on the input and output shafts to study the effect of input and output mechanical impedances on gearbox dynamics.

The rig is instrumented to measure gearbox noise and dynamics. Measurement capabilities include: acoustic intensity, sound level, support structure forces, housing vibration, shaft lateral and torsional vibration and gear tooth strain. Sound absorbing material has been added to the test cell walls, ceiling, and floor to improve acoustic measurements. A robot is used to automate acoustic noise measurements.

### Significance

The test facility makes it possible to experimentally study the parametric effects of new gear tooth forms and other advanced concepts to reduce the noise in helicopter transmissions. The test facility is providing data to validate computer models for prediction of gearbox dynamics, vibration, and noise for a range of design variables. The data and validated computer codes resulting from the test program will provide a technology base for future quiet transmission designs.

## **GEAR NOISE RIG—FACILITY DESIGN & INSTALLATION**

**GEAR NOISE RIG**

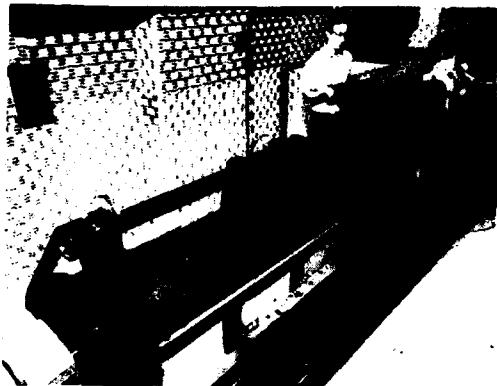

### **SIGNIFICANCE:**

- **PARAMETRIC STUDIES OF GEAR DESIGN VARIABLES**
- **VERIFICATION OF COMPUTER MODELS FOR GEAR DYNAMICS AND NOISE**
- **TECHNOLOGY BASE FOR FUTURE QUIJET TRANSMISSION DESIGN**

### **MILESTONES COMPLETED:**

- **DESIGN & FABRICATION OF HIGHLY-INSTRUMENTED TEST GEARBOX**
- **TEST RIG DESIGNED & CONSTRUCTED**
- **FACILITY IS FULLY OPERATIONAL**

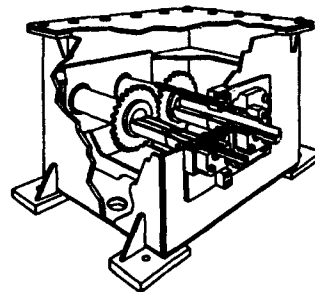

**TEST GEARBOX**

Figure 10.—Gear noise rig facility design and installation.

## GEAR DYNAMICS CODE VALIDATION

### Objective

The objective was to validate a gear dynamics computer code through experiments on the gear noise rig.

### Background

The major source of helicopter cabin noise is attributed to vibration generated by the numerous gear meshes within the gearbox and transmitted to the airframe. Noise levels in excess of 100 dB have been measured. This leads to pilot fatigue, disrupted communications, and unhealthy conditions for both crew and passengers. If helicopter transportation is to flourish in the civil transport markets, the cabin noise level must be drastically reduced. A NASA/Army helicopter transmission noise reduction research project was initiated to provide the basic information necessary for gear dynamic code validation in order to study gearbox vibration phenomena and subsequently reduce noise generation at the source.

Gear vibration is primarily caused by the abrupt transition of the load from tooth to tooth as the gears mesh. Modifications to the profile of gear teeth are often used to help smooth this dynamic action. The effects of tooth profile modification on gear dynamics is simulated by several computer codes developed through NASA grants and contracts. The gear dynamics codes can predict the loads on a gear tooth under a static condition as well as at typical operating speeds where the interaction of system mass and stiffness properties produces dynamic effects. As the gears rotate, the point of contact between the teeth moves along the profiles of the teeth. As this happens the magnitude of the contact force varies as a function of the rotational speed.

There has been an acute need to verify these codes with experimental data taken under carefully controlled conditions. The goal of this initial effort has been to verify predictions of the gear dynamics code DANST (Dynamic Analysis of Spur gear Transmissions) for both gear tooth loads and for the bending stress at the gear tooth root.

### Approach

Gear dynamics experiments were conducted in the Gear Noise Facility at NASA Lewis. An instrumented gearbox was tested under a range of speeds and loads in order to obtain experimental data to compare with the results of the DANST code. Test instrumentation included miniature strain gages installed in gear tooth roots, rotary accelerometers mounted on the gears, accelerometers mounted on the gearbox case and on the bearing mounts, and load cells mounted under the gearbox supports. Primary emphasis to date has been on gear tooth strain gage data which provides information on tooth bending stresses and on tooth-to-tooth loads.

## Results

Tests have been completed on a pair of standard involute spur gears with a linear profile modification. The test gear data is as follows: 28 teeth, 8 diametral pitch, 3.5 in. pitch diameter, 0.25 in. face width. The 28 test conditions included speeds from 800 to 6000 rpm and torques from 16 to 110 percent of the gear design torque.

Strain gages were used to measure the dynamic force acting between gear teeth. The experimental data was compared to analysis, and in all cases the waveforms are similar. This indicates that the analysis does simulate the physical behavior of the test gears. Also, the analysis successfully predicts loss of tooth contact that occurs when the gears are run at high speeds and with a light load.

The experimental peak value of the dynamic load was also compared with DANST predictions for all test conditions. The maximum dynamic load prediction generally agreed with measurement results within 6 percent. Strain gages were used to also measure the bending stress at the tooth root for comparison with DANST predictions. The analysis generally agrees with measurement results for the tooth root location within 10 to 15 percent.

## Significance

The gear dynamics code DANST was validated by testing involute spur gears with linear profile modifications. The analytical predictions of gear tooth loads and bending stress were verified by experiment. The validated code will allow a gear designer to tune the profile of a new gear to minimize dynamic loads and stress with the potential to reduce noise and vibration without expensive and time-consuming hardware testing. The code will also predict the effects of load and speed on the dynamics of a gear system.

# GEAR DYNAMICS CODE VALIDATION

### MILESTONES COMPLETED:

- Compared analysis and experiment
- 28 test conditions
- Successfully predicts dynamic loads
- NASA TM 103232

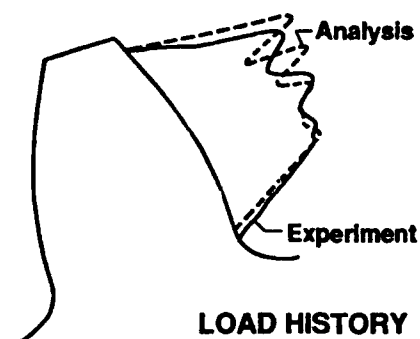

### SIGNIFICANCE:

- Experimental verification of gear dynamics code
- Allows tuning gear profile for minimum noise and vibration

Figure 11.—Gear dynamics code validation.

# IMPROVED COMPUTER PROGRAM FOR GEAR DYNAMICS

## Objective

The objective was to develop a comprehensive computer program to accurately model gear dynamic performance for a variety of gear train systems.

## Background

An important measure of rotorcraft performance is the ability of the rotorcraft to efficiently carry a maximum amount of payload at a given input power level. To meet this challenge, current rotorcraft transmissions are designed for high capacity and reduced weight. Minimizing transmission weight results in lightweight and flexible transmission components. Unfortunately, as a structure becomes lighter and more flexible it also becomes more susceptible to vibration and noise generation. Addressing excessive noise and vibration problems on production transmissions is typically a costly and time consuming process. It is, therefore, crucial to be able to predict the dynamic performance of a proposed transmission at the design stage.

GEARDYNAMULT is a gear dynamics computer program currently used at NASA Lewis to predict dynamic performance on a variety of gear train systems. Prior to being upgraded, the ring gear rim, carrier, and sun gear center were assumed to be rigid. Because transmission components are becoming lighter and more flexible, it became necessary to revise the computer program to more accurately model current transmission designs. This was accomplished by adding flexibility in the dynamic model. For a typical planetary system the model now has the option to include sun center, ring gear, and planet carrier flexibility along with sun center damping.

A detailed treatment of the dynamics at each gear mesh is performed by the program. Each tooth pair in contact is represented by a spring in contact with a cam. To model the variable stiffness of meshing teeth the springs are assigned variable spring rates that are dependent on their relative position on the cam. The mass represents the rigid body inertias of the gears in mesh, and the damping is the total mesh damping. The profile modification used to ease the tooth loading during engagement and disengagement of the tooth pairs is modeled by the geometry at the front and rear face of the cam. Dynamic effects are found by having the cam move at a velocity equivalent to the tooth velocity along the line of action.

## Approach

NASA Lewis contracted Hamilton Standard Division of United Technologies Corporation to upgrade the existing gear train dynamic analysis program GEARDYNAMULT.

## Results

The existing gear dynamic analysis program GEARDYNAMULT was upgraded to more accurately model transmission systems through the use of the following new options:

- **Floating sun center option:** Most epicyclic gear systems have a sun gear that can move in the in-plane translational directions. This option thus allows the designer to determine the effects of different flexibilities and damping values at the sun center on the dynamic tooth loads.

- **Flexible carrier/ring gear rim option:** Lighter and more flexible transmission components often result in higher dynamic loads. This option allows the user to investigate the effects on dynamic tooth loads of various ring gear rim and carrier flexibilities.

- **Natural frequency option:** This option is useful to the designer in determining critical speeds based on the system masses, mesh stiffnesses, and optional ring gear rim, carrier, and sun center flexibilities.

- **Refined finite elements analysis:** This option allows the user to obtain more accurate tooth pair compliance curves for helical gearing systems.

More detailed information can be obtained in NASA CR-179563, "Expansion of Epicyclic Gear Dynamic Analysis Program" by Boyd and Pike.

### Significance

A variety of gear trains can be optimally designed with a minimum of research and test time by using the upgraded GEARDYNMULT program which dynamically models the gear train in detail at the design stage.

## IMPROVED COMPUTER PROGRAM FOR GEAR DYNAMICS

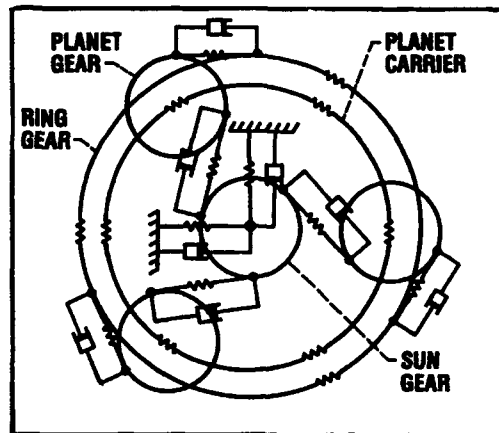
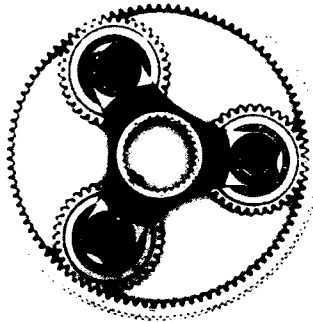

### MILESTONES COMPLETED:

- PROGRAM GEARDYNMULT WAS IMPROVED BY ADDING:
  - FLOATING SUN CENTER
  - FLEXIBLE CARRIER
  - FLEXIBLE RING GEAR RIM
  - NATURAL FREQUENCY ROUTINE
  - REFINED FINITE ELEMENT ROUTINE
- NASA CR-179563

### SIGNIFICANCE:

- DETAILED MODELING OF ACTUAL SYSTEM WITH MORE ACCURATE RESULTS
- REDUCES DEVELOPMENT TIME AND EXPENSES WHEN USED AS A DESIGN TOOL

Figure 12.—Improved computer program for gear dynamics.

# ANALYTICAL STUDY OF DYNAMIC LOAD EFFECT ON GEAR PITTING FATIGUE LIFE FOR LOW-CONTACT-RATIO SPUR GEARS

## Objective

The objective was to analyze the effect of dynamic load on gear pitting fatigue life and investigate how design and operating parameters affect gear load and life.

## Background

Pitting fatigue is a natural wearout mode of gear failure and occurs even under ideal operating conditions with proper lubrication and stress levels. For each hour of operation there is a reliability level which can be calculated. Earlier work at NASA provided an analytical methodology for calculating life and reliability for gears assuming a quasistatic load on the gear teeth. It was desired, therefore, to improve upon this methodology by replacing the quasistatic load assumption with calculated dynamic loads in the life and reliability model.

In reality, contact loads on mating gear teeth vary as the gears rotate through their mesh. This is known as dynamic load. Studies under NASA sponsorship have shown that gear dynamic loads deviate appreciably from ideal static forces for certain gear designs and operating conditions. Predicted life resulting from gears operating under dynamic loads, however, was unknown. Published literature on the subject was generally outdated and conservative. A need was perceived to investigate dynamic load and relate it to gear life and reliability.

## Approach

Work was performed in-house at NASA Lewis by combining an existing gear dynamic load analysis computer program with the NASA gear life model. Improvements to the dynamic load analysis were made followed by parametric studies of gear life.

## Results

TELSGE, a NASA gear dynamic load prediction program, was modified to include an improved gear tooth stiffness model, a tooth stiffness-dynamic load iteration scheme, and a pitting-fatigue-life prediction analysis for a gear mesh. Parametric studies were performed that modeled low-contact-ratio involute spur gears over a range of gear speeds, numbers of teeth, gear sizes, diametral pitches, pressure angles, and gear ratios.

In general, gear life predictions based on dynamic loads differed significantly from those based on static loads. Gear mesh operating speed strongly affected dynamic load and life where the dynamic life factor,  $C_v$ , is defined as the mesh life based on dynamic loads divided by the life based on static loads. The normalized speed is the ratio of  $\omega$ , the mesh operating speed, to  $\omega_n$ , the predicted mesh resonant speed. In general, mesh operation at resonant speed had a detrimental effect on life while operation at high speed increased life cycles to failure.

Gear mesh contact ratio,  $c$ , defined as the average number of pairs of teeth in contact, also strongly affected predicted dynamic load and life. Higher contact ratio meshes had higher dynamic life factors and thus, an increase in their lives as compared to life predictions based on static loads.

Computer program TELSGE can predict gear tooth dynamic loads, mesh resonant frequencies, and mesh lives. Based on the parametric studies, a design chart was developed for use in the absence of a computer and program TELSGE. The results are available in NASA TP-2610, "Predicted Effect of Dynamic Load on Pitting Fatigue Life for Low-Contact-Ratio Spur Gears" by Lewicki.

### Significance

Gear mesh life can be increased through the improved analytical life prediction method. Gear mesh resonant speeds can be predicted and adverse affects on life can be avoided by modifying gear speed or design. In addition, life improvements can be achieved with the life prediction method through parametric studies and improved selection of gear design parameters.

## ANALYTICAL STUDY OF DYNAMIC LOAD EFFECT ON GEAR PITTING FATIGUE LIFE

### MILESTONES ACHIEVED:

- DEVELOPED A COMPUTER PROGRAM FOR DYNAMIC LOAD EFFECT ON LIFE
- PERFORMED PARAMETRIC TREND STUDY
- DEVELOPED GEAR LIFE DESIGN CHART
- NASA TP

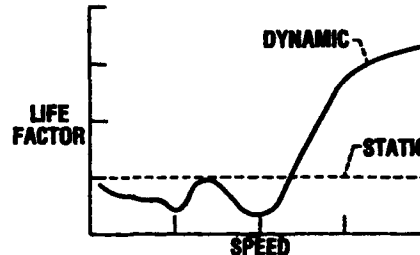
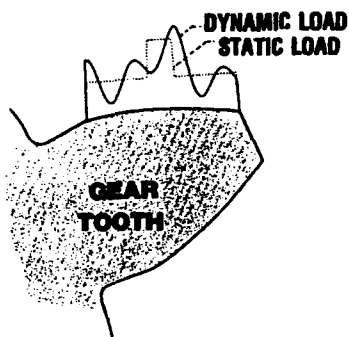

### SIGNIFICANCE:

- FIRST RIGOROUS ANALYSIS OF DYNAMIC LOAD EFFECT ON LIFE
- RESULTS SHOW OPERATING SPEED AND CONTACT RATIO SIGNIFICANTLY AFFECT LIFE
- USEFUL DESIGN TOOL FOR AIRCRAFT GEARING

Figure 13.—Analytical study of dynamic load effect on gear pitting fatigue life.

# COMPUTER PROGRAM FOR LIFE AND RELIABILITY OF HELICOPTER TRANSMISSIONS

## Objective

The objectives were to create analytical tools for predicting helicopter transmission life and reliability, to examine the design and operating parameters that affect transmission life, and, thereby, to increase the actual life and reliability for helicopter transmissions.

## Background

Life and reliability are important issues during the design, development, and field operation of helicopter transmissions. Light weight and high power capacity must be balanced with requirements for long life and low maintenance costs. In the past, analytical tools for predicting transmission life were not available. They are needed for design and for comparing competing and alternate designs.

Bearing and gear lives are major factors in determining total transmissions system life. Under ideal conditions of proper design, lubrication, and operation, bearings and gears will still fail by the pitting fatigue mode of failure. Pitting fatigue is the expected failure mode because there is no material endurance limit for bearings or gears.

Analytical models and computer programs for gear and bearing life have already been developed under NASA/Army sponsorship. Previous analytical studies were successful in applying those models to transmissions. The work was laborious and only several transmissions were studied, the results being published in several NASA reports. A need was perceived then for a more general computerized model capable of efficient analysis for a large variety of different transmission designs. A computer code of this type makes it possible to evaluate the life and reliability of proposed transmission designs, optimize those designs, and predict spare parts required over the useful life of the helicopter fleet.

## Approach

The basic NASA analytical models were refined and combined into a single analytical model, and the model was applied to predict the life of spiral bevel gears, planetary gears, and various combinations of gears and bearings.

## Results

A computer program was developed to predict helicopter transmission life. The program can analyze a variety of configurations composed of spiral bevel gear meshes and planetary gear meshes. Spiral bevel reductions may have single or dual input pinions and gear shafts can be straddle mounted or overhung on the support bearings. The planetary reduction has the sun gear as input, the planet carrier as output, and the ring gear fixed. The planet gears may be plain or stepped and the number of planets may vary.

The program determines the forces on each bearing and gear for a given transmission configuration and loading. The life of each bearing and gear is determined using the fatigue life model appropriate to that component. The transmission system life is determined from the component lives

then be found. Program output consists of component and total system lives and dynamic capacities. Further details are reported in NASA CR-3967, "System Life and Reliability Modeling for Helicopter Transmissions" by Savage and Brikmanis.

### Significance

A versatile computer program has been developed for predicting helicopter transmission life and reliability. The program will apply to a variety of transmission configurations and operating conditions. The program is a valuable tool for evaluating preliminary designs and comparing competing and alternate designs. From the life predictions, the mean time between failures can now be calculated using rigorous statistical methods.

#### HELICOPTER TRANSMISSION LIFE AND RELIABILITY COMPUTER PROGRAM

##### **SIGNIFICANCE:**

- **VERSATILE COMPUTER PROGRAM FOR PREDICTING TRANSMISSION LIFE AND RELIABILITY**
- **TOOL FOR EVALUATING PRELIMINARY AND COMPETING DESIGNS**
- **PROVIDES INFORMATION THAT CAN BE USED TO PLAN SPARE PARTS REQUIRED**

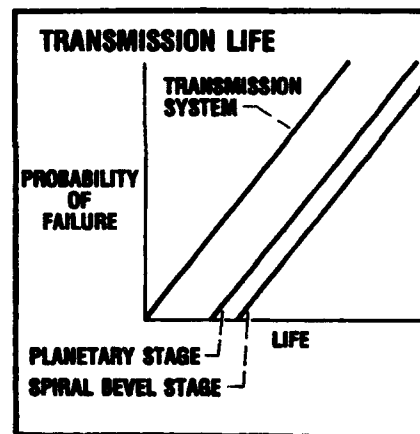
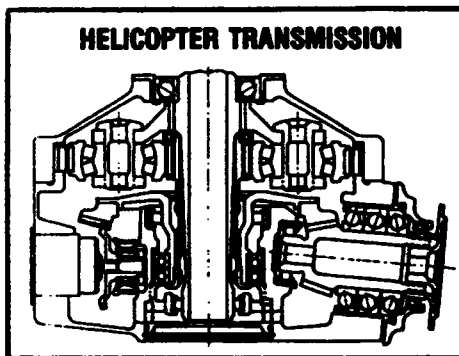

##### **FEATURES:**

- **INPUTS: TRANSMISSION CONFIGURATION, LOAD, AND SPEED**
- **OUTPUTS: TRANSMISSION COMPONENTS AND SYSTEM LIVES**

Figure 14.—Helicopter transmission life and reliability computer program.

# VIBRATION CHARACTERISTICS OF THE OH-58A HELICOPTER

## MAIN ROTOR TRANSMISSION

### Objective

The objective was to establish a vibration data base for the 300 to 500 hp class helicopter transmissions.

### Background

Transmissions are the main source of noise in today's helicopter interiors with the noise originating from the gear mesh. The standard approach to quieting the helicopter interior is to add cabin acoustic material. This adds a weight penalty, which opposes the desire for ever-increasing power-to-weight ratios for helicopter drive systems. Therefore, research is being directed to transmission noise reduction. A first step was to establish a vibration data base for present-day technology helicopter transmissions. The results can serve as baseline data in comparison with measured results from future technological improvements in components and total system design, manufacturing techniques, or materials.

### Approach

Experimental vibration tests were conducted in the NASA Lewis 500 HP Helicopter Transmission Test Stand. The tests were performed on the U.S. Army OH-58A helicopter main rotor transmission.

### Results

Seven accelerometers were mounted at various locations on the OH-58A transmission housing. Vibration tests were conducted using a matrix of torque and speed conditions covering transmission input torques of 176 to 352 N-m (1559 to 3119 lb-in.) and transmission input speeds of 3000 to 6000 rpm. Accelerometer signals were analyzed by digital signal processing techniques.

The dominant sources of transmission vibration were the spiral bevel gear mesh and the planetary gear mesh. The highest vibration amplitude occurred at the spiral bevel gear meshing frequency, measuring about 5 g's at location number 1 during full speed and torque conditions. Overall broadband acceleration ranged from 2 to 10 g's rms depending on speed and torque conditions. Transmission speed had a significant effect on vibration levels while transmission torque had a small effect. At the same speed and torque conditions, measured vibration levels were different for different measurement locations. Measured vibration levels were the same for different measurement directions at the same location. There was no trend as to the effect of torque or speed on spiral bevel mesh or planetary mesh vibration contributions as a percentage of total vibration. The complete results for the baseline measurements are reported in NASA TP-2705, "Vibration Characteristics of the OH-58A Helicopter Main Rotor Transmission" by Lewicki and Coy.

## Significance

This work establishes the measurement and data reduction methodology for vibration testing of helicopter transmissions in the 300 to 500 hp class. The results of the vibration tests serve as baseline data for comparison with measured results from future advanced technology transmissions. The vibration tests have identified the spiral bevel gear as the largest source of vibration and therefore future research should be directed to reducing this source of vibration.

### **VIBRATION CHARACTERISTICS OF THE OH - 58A HELICOPTER MAIN ROTOR TRANSMISSION**

#### **MILESTONES ACHIEVED:**

- COMPLETED TESTS & DATA ANALYSIS
- GEAR MESHES ARE DOMINANT SOURCE OF NOISE
- HIGHEST AMPLITUDE IS 5 G'S AT SPIRAL BEVEL MESHING FREQUENCY
- NASA TP - 2705

#### **VIBRATION SPECTRUM**

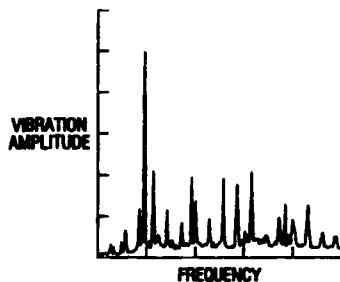

#### **NASA 500 HP TEST STAND**

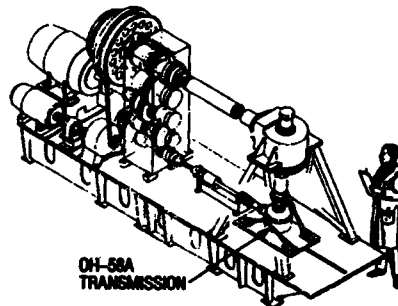

#### **SIGNIFICANCE:**

- DATA BASE FOR 500 HP CLASS TRANSMISSIONS
- TESTING & DATA REDUCTION METHODOLOGY ESTABLISHED

Figure 15.—Vibration characteristics of the OH-58A helicopter main rotor transmission.

# PLANETARY GEAR TRAIN EFFICIENCY STUDY

## Objective

The objective was to experimentally test a transmission planetary gear stage over a wide variety of operating conditions and compare measured efficiency to computer predicted values.

## Background

Helicopter transmissions are very efficient. Depending on operating parameters such as speed, load, and temperature, the efficiency of the complete helicopter transmission is typically above 97 percent. However, even a slight improvement in efficiency can have an effect on the complete transmission system. Changes in operating parameters, such as reduced volume of lubricant or increased lubricant temperature, may yield only a small improvement in efficiency, but offer multiple benefits in the reduced size/weight of the oil cooler, and reduced vulnerability.

Helicopter transmission efficiency is usually determined by testing the complete transmission. However, in this type of testing it is difficult to distinguish the effects of individual components on transmission efficiency. Isolation of individual components, such as the planetary gear train, allows direct control of operating conditions and permits a wide range of test parameters.

## Approach

A parametric test program was conducted using a helicopter transmission planetary gear train installed in NASA Lewis' Planetary Gear Test Rig. Analytical efficiency results obtained using NASA computer codes were compared to those determined experimentally.

## Results

A parametric study was performed on a helicopter transmission planetary stage having a four-planet configuration and is reported in NASA TP-2795, (AVSCOM TR 87-C-28), "Efficiency Testing of a Helicopter Transmission Planetary Reduction Stage" by Handschuh and Rohn. Two planetary stages were driven in a back-to-back, test/slave arrangement. A total of 130 different conditions were tested. Test parameters included sun-gear speeds to 1622 rpm and input torque to 1840 N\*m (16 300 in.\*lb). Two different gear lubricants were used, flow rates were varied, and oil inlet temperature was changed to experimentally measure the effect of these parameters. Experimentally measured efficiency over all the test variables ranged from 99.44 to 99.75 percent.

Analytical performance predictions were made and compared to measured results. The analytical results were obtained by modeling the test hardware and operating conditions. Computer programs that predict power loss for external gears, internal gears, and the planetary bearings were used. Generally, the trends in efficiency with parametric variations were similar for the analysis and experiment, but the analytical results predicted higher efficiencies than were experimentally measured. The difference between the experimental and analytical results is believed to be due to gear pumping losses that are not accounted for in the analytical model. It is now suspected that the gear pumping loss, which was

previously believed to be negligible, is important in jet lubricated gear meshes operating at low speeds as the planetary gears did in this experimental study.

### Significance

Planetary drivetrain components were experimentally tested, and results were compared to analytical predictions. Analytical predictions followed the trends found in the experimental data. The computer code is partially validated, but it must be improved by adding methods to calculate the gear pumping losses.

## PLANETARY GEAR TRAIN EFFICIENCY STUDY

### MILESTONES COMPLETED:

- PARAMETRIC STUDY COMPLETED
- ANALYTICAL AND EXPERIMENTAL RESULTS COMPARED
- NASA TP-2795

### PLANETARY TEST HARDWARE



### EFFICIENCY RESULTS

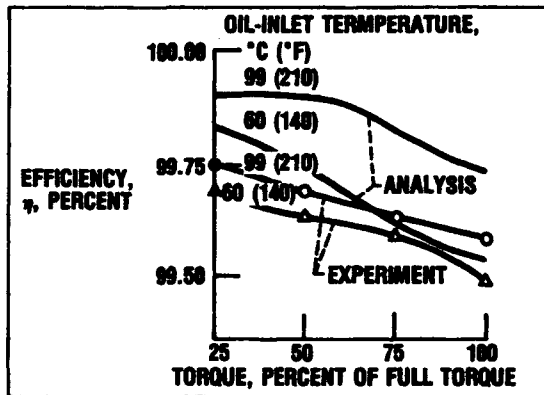

### SIGNIFICANCE:

- ANALYTICAL AND EXPERIMENTAL RESULTS FOLLOWED SIMILAR TRENDS
- SENSITIVITY OF PLANETARY PERFORMANCE TO TEST PARAMETERS MEASURED

Figure 16.—Planetary gear train efficiency study.

## **EXPERIMENTAL RESULTS FOR UH-60 HELICOPTER TRANSMISSION**

### **Objective**

The objective was to obtain vibration and mechanical efficiency data for a modern helicopter transmission.

### **Background**

The transmission is a very important part of a helicopter propulsion system. Improvements are continually being sought for transmission weight, reliability, efficiency, noise, and life. Higher power-to-weight ratios for the transmission, for example, can result in higher payload or greater range for the helicopter. Higher transmission efficiency would mean more useful power available as well as less heat rejection required, which in turn means a smaller (and thus lighter) oil cooler can be used. Noise reduction is desirable for reduced pilot fatigue as well as increased passenger comfort.

These improvements can come at either the component or system level; however, what was needed was a data base against which future improvements could be measured. The modern transmission for the UH-60 was chosen for testing.

### **Approach**

The mechanical efficiency and vibration characteristics of the UH-60 transmission were experimentally determined by installing it in the NASA Lewis 3000-hp transmission test facility. Data were obtained for input speeds and loads ranging from 50 to 100 percent of the rated values.

### **Results**

The efficiency and vibration tests were completed. With an oil inlet temperature of 355 K (180 °F), the overall efficiency was 97.3 percent at the full rated load and speed condition. Measured vibration readings were from 6 to 50 g's rms at the 100-percent power condition. The highest vibration reading was 72 g's rms, measured on the upper housing. A technical report has been published.

### **Significance**

A data base has been established against which future component or system design improvements can be compared.

## EXPERIMENTAL RESULTS FOR VIBRATION AND EFFICIENCY TESTING OF AN ADVANCED 3000 hp HELICOPTER TRANSMISSION



**MILESTONE ACHIEVED:  
FULL SCALE PARAMETRIC DATA ANALYSIS  
OF U.S. ARMY BLACKHAWK TRANSMISSION  
COMPLETED.**

- DATA BASE ON 3000 hp CLASS TRANSMISSIONS ENHANCED
- TECHNICAL REPORT PUBLISHED
- MAXIMUM EFFICIENCY 97.3% WITH 190 °F OIL TEMPERATURE
- PEAK MEASURED VIBRATION 72 g-rms ON UPPER HOUSING

**SIGNIFICANCE:  
ESTABLISHED DESIGN AND PERFORMANCE  
EVALUATION ON ADVANCED COMPONENT,  
FULL SCALE HELICOPTER TRANSMISSION.**

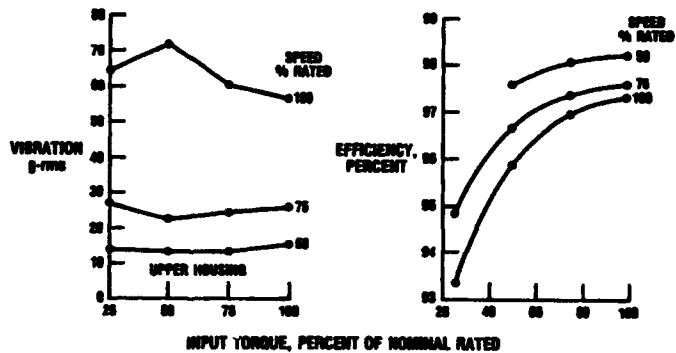

Figure 17.—Experimental results for vibration and efficiency testing of an advanced 3000 hp helicopter transmission.

# GEAR TOOTH STRESS MEASUREMENTS ON UH-60A HELICOPTER TRANSMISSION

## Objective

The objective was to obtain experimental stress data from gear teeth in a UH-60A helicopter transmission.

## Background

Helicopter transmission designers are continually striving for improvements in transmission life, reliability, and power-to-weight ratio. To accomplish these goals, designers must be able to accurately predict stress levels in transmission components under realistic operating conditions. Prediction of gear stress can be a difficult problem because of complicated gear geometry and complex, time-varying dynamic loading.

Realistic stress data for helicopter gear teeth were needed to establish a data base for comparison with existing design and computer codes that simulate gear tooth stress.

## Approach

An instrumented UH-60A transmission was tested in the NASA Lewis 3000-hp transmission test facility at loads ranging from 25 to 100 percent of the rated values. Strain gages were placed on the sun, ring, and combining spiral bevel pinion gears at five points across the tooth face width. Two locations along the tooth profile were used: (1) fillet gages were placed at the 30° tangency location on the loaded side of the tooth fillet to measure maximum tooth bending stresses and (2) root gages were placed in the center of the tooth root to measure rim bending stress.

## Results

Tests have been completed. Typical experimental stress traces for a combining spiral bevel pinion are shown. Traces from five gages have been superimposed to show stress variation across the face width. Phase differences between traces are due to the stress distribution sweeping across the curved tooth surface as the gear rotates. Fillet gages show high tensile stress levels due to tooth bending. Root gages (not shown) produce a larger compressive stress due to bending of the gear rim under the teeth.

The highest gear tooth stress found was on the combining pinion. At 100 percent torque, mean and alternating stress values at this location were 330 and 430 MPa (48 and 62 ksi).

A typical experimental stress trace of the ring gear for one tooth engagement is shown compared to an analytical simulation from the computer program GRDYNMLT. In the analytical simulation, gear teeth are represented as linear springs connecting rigid gear bodies. Damping is modeled as a constant damping ratio. The damping ratio used in the example shown is 0.02 (2 percent).

There are two obvious differences between the analytical and experimental traces: (1) High frequency oscillations in the analytical trace do not appear in the experimental data and (2) the compressive stress of the experimental data does not appear in the analytical trace. The model has a

higher frequency response than the actual transmission because the chosen damping ratio (2 percent) is fairly low and structural damping is not modeled. The ring gear is modeled as a rigid body, and, therefore, the compressive stress due to bending of the ring gear body does not occur in the analytical simulation. The differences between the analytical and experimental traces identifies the need to refine the computer codes to include the effects of structural damping and ring gear body deformations.

The analytical simulation is believed to model tooth bending stress reasonably well if the damping ratio is properly chosen. The maximum ring gear fillet stress measured was 410 MPa (59 ksi) which is 11 percent lower than that obtained analytically.

Further information on this work is given in NASA TP-2698, "Gear Tooth Stress Measurements on the UH-60A Helicopter Transmission" by Fred B. Oswald, 1987.

### Significance

This work provides experimental data, from realistic operating conditions, useful for understanding gear stress and validating computer simulations. A data base has been established for comparison with future transmission development. Also a stress measurement methodology has been established. Finally, a need for refined computer codes has been identified.

## GEAR TOOTH STRESS MEASUREMENTS ON UH 60A TRANSMISSION

### MILESTONES COMPLETED:

- DATA BASE ESTABLISHED FOR SPIRAL BEVEL & PLANETARY GEARS
- DEVELOPED COMPUTERIZED STRESS DATA REDUCTION
- EXPERIMENTAL & ANALYTICAL RING GEAR PEAK STRESSES AGREE WITHIN 11%
- NASA TP 2698

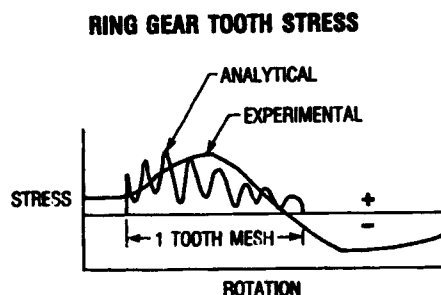

### SPIRAL BEVEL STRESS

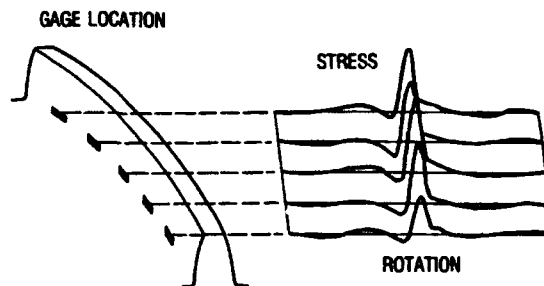

### SIGNIFICANCE

- DATA FOR VALIDATION OF COMPUTER CODES
- DOCUMENTS CURRENT TECHNOLOGY FOR HELICOPTER GEAR STRESS
- IDENTIFIES NEED FOR IMPROVED ANALYTICAL CODES

Figure 18.—Gear tooth stress measurements on UH 60A transmission.

# DESIGN AND MANUFACTURING OF HIGH-RATIO SELF-ALIGNING BEARINGLESS PLANETARY (SABP) TRANSMISSION

## Objective

The objectives were to improve power-to-weight ratio, reliability, and efficiency and to reduce noise of rotorcraft transmissions.

## Background

In the early 1970's, the U.S. Army investigated the self-aligning bearingless planetary (SABP) concept. A small development version of the planetary unit was manufactured and tested to prove the feasibility of the concept. The concept showed promise in the development tests so several studies were made to assess the feasibility of the SABP as a possible helicopter transmission. These studies indicated there was a potential advantage in weight, efficiency, and reliability by using the SABP concept and recommended the design and development of a 500-hp version for a helicopter transmission.

NASA designed and manufactured a 500-hp low-ratio spur gear SABP and conducted testing of the transmission in the NASA 500-hp transmission test stand. Additional studies have shown that the advantage of the SABP over conventional transmissions is greater at higher input-to-output ratios and that a helical gear system would provide reduction in helicopter transmission noise.

It was therefore decided to design, manufacture, and evaluate a 450-hp high-ratio helical gear SABP transmission and conduct an experimental evaluation of it in the NASA 500-hp transmission test facility and compare the results with a conventional transmission. The OH-58 helicopter has an engine rpm of 35 500 with an engine reduction gearbox to reduce this speed to 6080 rpm for the main rotor transmission input speed. A design objective of the high-ratio helical SABP transmission was to utilize the engine speed of 35 500 rpm and have the total reduction to the 348 rpm main rotor speed in one transmission. The design and performance goals of the high-ratio SABP helical transmission were:

- (1) Input speed of 35 500 rpm with a total reduction ratio of approximately 100 to 1.
- (2) A weight improvement over the conventional transmission.
- (3) Reduce noise and vibration levels below those of conventional helicopter transmissions.
- (4) Improve the transmission reliability above that for conventional helicopter transmissions.

## Approach

NASA Lewis contracted for the design and manufacture of two high-ratio 100:1, 450-hp helical SABP transmissions.

## Results

The 450-hp helical SABP transmission design was completed. The design included high contact ratios for both the spiral bevel and the helical gears. All gear meshes were designed with an overall contact ratio of three or greater to improve the gear dynamics and reduce noise. The gear tooth pitting resistance and bending strength were optimized to give the transmission a high reliability and long life. The absence of planetary bearings improves the reliability and weight over the conventional transmission since the planetary bearings in conventional transmissions are heavy and are the shortest-lived part in the transmissions.

The SABP type transmission can be designed with various profiles such as "wide and short" or "tall and thin" because of the balance system used to design the bearingless planetary spindles. An improved manufacturing technique was developed to provide accurate positioning of the gear teeth on the three spindle gears while they were electron beam welded to each other. This special fixture provided the necessary gear tooth location accuracy for the three gears relative to each other.

Two high-ratio 450-hp SABP transmissions were manufactured, with the actual weight-to-power density of 0.33 lb/hp. This density is significantly lower than those for conventional helicopter transmissions. A complete design report is available, NASA CR-4155, "Design, Manufacture, and Spin Test of High Contact Ratio Helicopter transmission Utilizing Self-Aligning Bearingless Planetary (SABP)" by Folenta and Lebo.

## Significance

The high-ratio helical SABP transmission has a specific weight of 0.33 lb/hp which is better than that for a conventional transmission (0.37). It also has a design life of 10 000 hr compared to 5000 hr maximum for conventional transmissions and promises much higher reliability because of the elimination of all planetary bearings. The high-ratio helical SABP shows promise of considerable reduction in noise level and a higher efficiency over conventional transmissions.

### **HIGH RATIO SELF-ALIGNING BEARINGLESS PLANETARY (SABP) TRANSMISSION— DESIGN AND MANUFACTURE**

#### **MILESTONES COMPLETED:**

- DESIGN OF HIGH RATIO HELICAL SABP TRANSMISSION
- IMPROVED MANUFACTURING METHOD DEVELOPED
- TWO TRANSMISSIONS MANUFACTURED
- NASA CR 4155

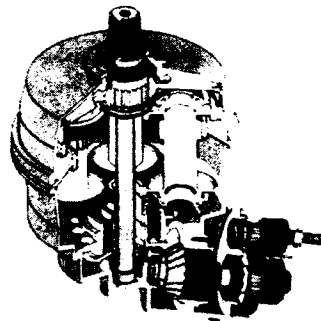
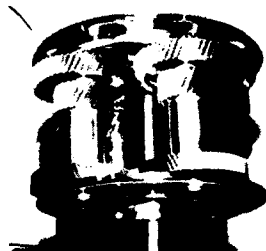

#### **SIGNIFICANCE:**

- REDUCED TRANSMISSION SPECIFIC WEIGHT
- IMPROVED RELIABILITY AND LIFE
- LOW NOISE HELICAL GEARS
- HIGHER EFFICIENCY

Figure 19.—Design and manufacture of high ratio self-aligning bearingless planetary (SABP) transmission.

## 3600 HP SPLIT-TORQUE HELICOPTER TRANSMISSION

### Objective

The objective was to improve the effectiveness of helicopter transmissions by increasing the power-to-weight ratio and reliability.

### Background

Improvements in power-to-weight ratio of helicopter power transmissions allow either higher carrying capacity (payload) or longer flight range for the vehicle. Improvements in reliability can be directly converted to longer mean time between unscheduled removals (MTBUR) and lower maintenance costs. These improvements can be accomplished by either (1) advancing the technology of the transmission components, such as with better bearing and gear materials or (2) by improving the drivetrain configuration, such as using a split-torque design. Fundamental to the split-torque type of transmission is that the power and torque from the engine is divided between two parallel paths prior to recombination on a single gear that drives the transmission output shaft. Studies have shown that elimination of a planetary reduction stage should result in a lighter transmission and that the parallel paths increase the reliability.

### Approach

A design study was undertaken to examine the possible benefits of improved drivetrain arrangements based on a split-torque principle, compared with a conventional planetary type design.

### Results

The split-torque design configurations were based on either three, four, or five final-drive pinions, for a twin input, 3600-hp transmission, with output rotor speed of 258 rpm and an overall speed reduction of 81:1. The four-pinion design was selected for further development based on:

- least overall weight
- reduced power losses
- comparable totals of gears and bearings
- only one nonredundant gear

The four-pinion design was deemed the optimum configuration. The design was completed to the detailing level under the conditions that it be a test transmission for further experimental validation in the NASA Lewis 3000-hp helicopter transmission test stand. The design was also carried out under the requirement that it be generally compatible with the Army's Blackhawk Helicopter (UH-60) and that a growth potential to 4500 hp be allowed for. Further details are reported in NASA CR-174932, "3600 HP Split Torque Helicopter Transmission" by White.

## Significance

The engineering analysis showed that the following performance benefits can be achieved for a 3600-hp split-torque transmission, compared to the conventional planetary:

- Weight is reduced 15 percent.
- Drivetrain losses are reduced 9 percent.
- Reliability is improved by redundant paths.
- The number of noise meshes is reduced (from engine to main shaft).
- The transmission has potential for installation and operation in a UH-60A Blackhawk Helicopter. Modifications would be required to do this.

## **3600 hp SPLIT TORQUE HELICOPTER TRANSMISSION, DESIGN STUDY**

### **SIGNIFICANCE:**

- **WEIGHT REDUCTION 15%**
- **IMPROVED RELIABILITY USING REDUNDANT POWER PATHS**
- **POWER LOSSES REDUCED 9%**
- **NUMBER OF NOISE MESHES REDUCED 38%**

### **MILESTONES COMPLETED:**

- **BLACKHAWK HELICOPTER COMPATIBILITY REQUIREMENTS STUDY**
- **CONFIGURATION OPTIMIZATION**
- **TEST TRANSMISSION DETAIL DESIGN**

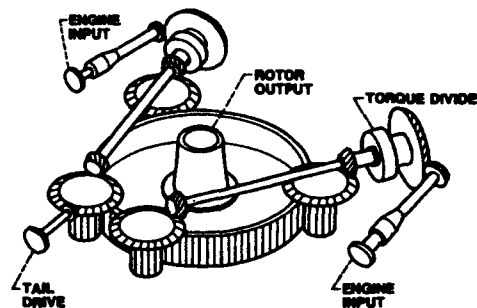

### **OTHER FEATURES:**

- **GROWTH POTENTIAL 3000 hp TO 4500 hp**
- **POTENTIAL REPLACEMENT FOR BLACKHAWK HELICOPTER TRANSMISSION**

Figure 20.—Design study of 3600 hp split torque helicopter transmission.

# ADVANCED ROTORCRAFT TRANSMISSION PROGRAM

## Objective

The objective was to identify key component and subsystem technologies to attain the weight, noise, and life goals of the advanced rotorcraft transmission program. The specific drivetrain goals are: (1) a 25-percent reduction in weight; (2) a 10-dB reduction in noise, and (3) a 5000-hr mean time between removal (MTBR).

## Background

Historically, technology advancements in airframes, rotors, and engines have been continuously integrated into rotorcraft. The integration of advances in drivetrain technology, however, has been lagging. In general, advancements resulted only in areas where problems occurred. Thus, three major shortcomings exist today in rotorcraft drivetrains: excessive weight, excessive noise generation, and short life. The Advanced Rotorcraft Transmission (ART) Program was initiated to meet and overcome these shortcomings.

The ART program is an Army-funded, joint Army/NASA program. Its intent is to develop and demonstrate lightweight, quiet, durable drivetrain systems for next generation rotorcraft. The four major contract participants in ART are: McDonnell Douglas Helicopter Company, Boeing Helicopters, Bell Helicopter Textron, and Sikorsky Aircraft. NASA Lewis is also providing in-house technical support and testing. ART addresses the general requirements of two distinct next-generation aircraft classes: (1) Future Air Attack Vehicle, a 10 000 to 20 000 lb aircraft capable of undertaking tactical support and air-to-air missions; and (2) Advanced Cargo Aircraft, a 60 000 to 80 000 lb aircraft capable of heavy lift field support operations. The ART program includes both tiltrotor and more conventional helicopter configurations. Specific objectives of ART include reduction of drivetrain weight by 25 percent compared to baseline state-of-the-art drive systems configured and sized for the next-generation aircraft, reduction of noise level at the transmission source by 10 dB relative to the suitably sized and configured baseline, and attainment of at least a 5000 hr MTBR.

## Approach

The technical approach toward achieving the ART goals includes use of new ideas in gear configuration, transmission concepts, and airframe/drivetrain integration. Also included is the application of the latest available component, material, and lubrication technologies. All four contracts have the same format and contents. The tasks of the contracts are:

- Task 1: Establish a baseline aircraft and transmission
- Task 2: Perform transmission configuration studies and choose the most promising configuration
- Task 3: Perform mission studies to determine the effect of the advanced transmission on the aircraft
- Task 4: Identify and design critical components required for the advanced transmission
- Task 5: Develop a component test plan
- Task 6: Fabricate the test rigs
- Task 7: Fabricate the test specimens
- Task 8: Test the components

In addition, in-house technical support is also being provided at NASA Lewis. Cooperative projects between NASA Lewis and the contractors have been established. McDonnell Douglas, Boeing, and Bell will provide hardware to test in the unique NASA Lewis facilities

Candidate drivetrain systems have been carried to a conceptual design stage. Tradeoff studies have been conducted resulting in selection of the ART transmission for each contractor. The selections were based on comparative weight, noise, and reliability studies. Preliminary designs of each ART transmission have been completed, as have mission impact studies. Comparisons of aircraft mission performance and life cycle costs were undertaken for the next-generation aircraft with ART and with the baseline transmission.

The success of the ART configurations in meeting the program goals depends on the successful incorporation of certain critical, advanced technologies into the preliminary designs. Each of the four contractors developed their component test plans. Key components and subsystem technologies were identified to attain the weight, noise, and life goals of the Advanced Rotorcraft Transmission program. The objective of the testing is to demonstrate the critical component technologies and subsystems which will be used for the advanced rotorcraft transmission. Identification of these key components resulted from the detailed design analysis of each chosen configuration for the ART program.

### Results

Results obtained from completion of the first five tasks of the contracts for each of the four major contractors are presented on the pages that follow.

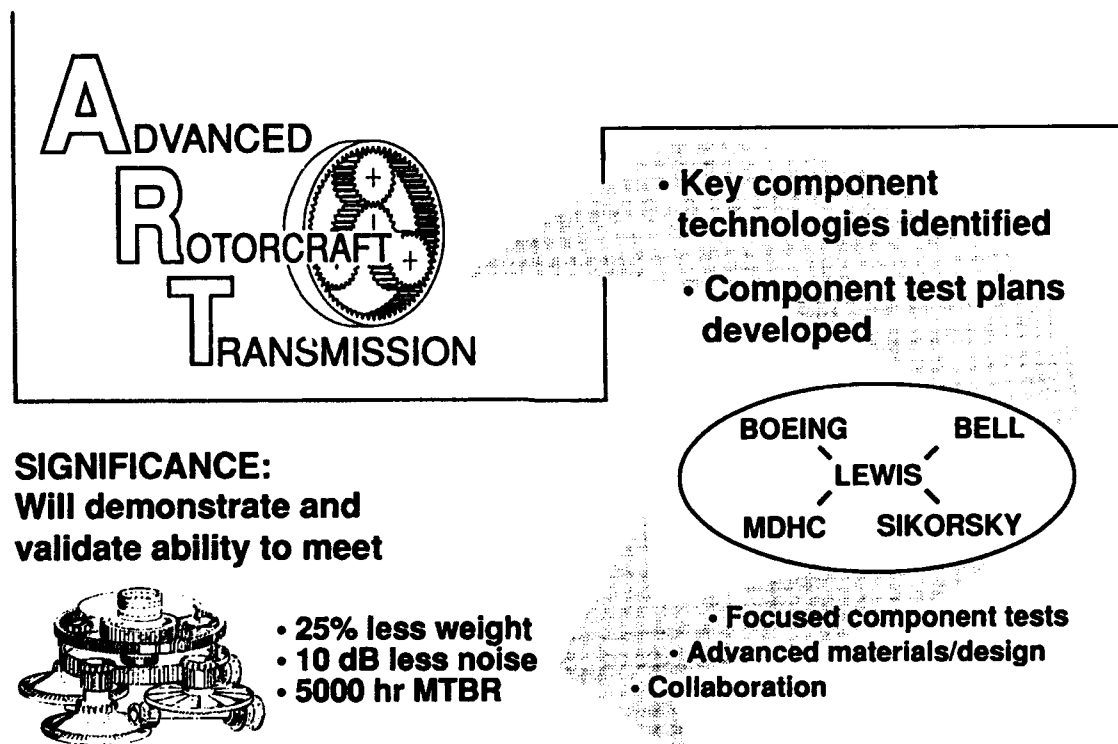

Figure 21.—Advanced Rotorcraft Transmission (ART) program overview.

## BELL HELICOPTER TEXTRON INC.

### ADVANCED ROTORCRAFT TRANSMISSION (ART) PROJECT

Bell Helicopter Textron Inc. selected for their application the Future Air Attack Vehicle (FAAV). They defined as their baseline a tiltrotor aircraft and chose a high contact ratio planetary stage as their advanced technology configuration.

Based on the trade studies, preliminary design, and life cycle cost evaluation, the chosen configuration can meet the three main goals of the project while lowering the life cycle cost of a fleet of aircraft that is based on the chosen FAAV. A 31 percent reduction in weight has been attained (utilizing a hot running lubrication system), a 6 to 10 dB reduction in source noise, and MTBR well in excess of 5000 hr has been predicted for the ART transmission. A \$333M life cycle cost savings for the aircraft fleet is estimated due to the ART program research.

Bell Helicopter is concentrating their component test program in three major areas: planetary gear train tests, material tests, and spiral bevel gear tests. The planetary gear train will be tested for noise/vibration, efficiency, fatigue, and loss of lubricant. Material testing will be done in coupon and full-scale hardware. X-53 gear steel will be extensively studied to assess heat treatment effects on bending fatigue. Investment cast titanium housing and planetary carrier will be assessed in conjunction with other component tests. High temperature magnesium will be tested and compared to current magnesium transmission housings for creep and corrosion. NASA Lewis and Bell established a joint project to test spiral bevel gears in the NASA 500-hp Test Stand. Spiral bevel gears will be tested to verify reduced noise and improved strength through changes in fillet/root design and gear tooth surface geometry. Strain gage surveys will determine bending stress reduction and noise/vibration tests will assess tooth geometry changes. Pitting, bending, and scoring tests will be conducted by Bell to verify component durability.

### ADVANCED ROTORCRAFT TRANSMISSION PROGRAM (BELL HELICOPTER TEXTRON INC.)

#### MILESTONES COMPLETED:

- MISSION, BASELINE, AND TRANSMISSION REQUIREMENTS
- TRADE-OFF STUDIES/PRELIMINARY DESIGN
- COST BENEFIT ANALYSIS

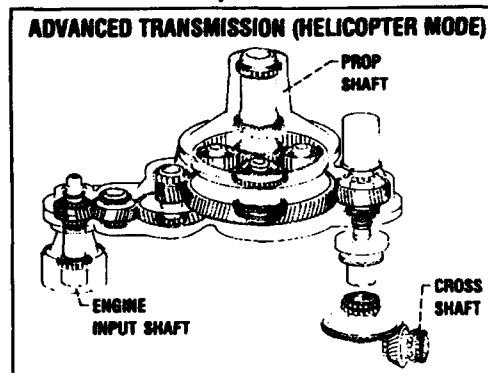
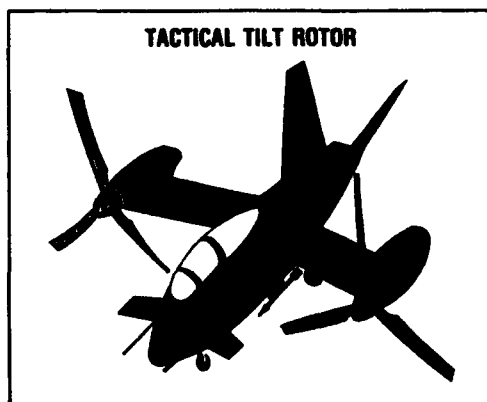

#### SIGNIFICANCE:

- PROGRAM GOALS FOR WEIGHT, NOISE, AND MEAN TIME BETWEEN REMOVAL ARE ATTAINABLE
- 296 lb TRANSMISSION WEIGHT REDUCTION
- \$333M LIFE CYCLE COST REDUCTION

Figure 22.—Bell Helicopter Textron Inc. ART program preliminary design.

## BELL HELICOPTER TEXTRON INC. ART PROGRAM

### Tactical Tilt-Rotor Transmission

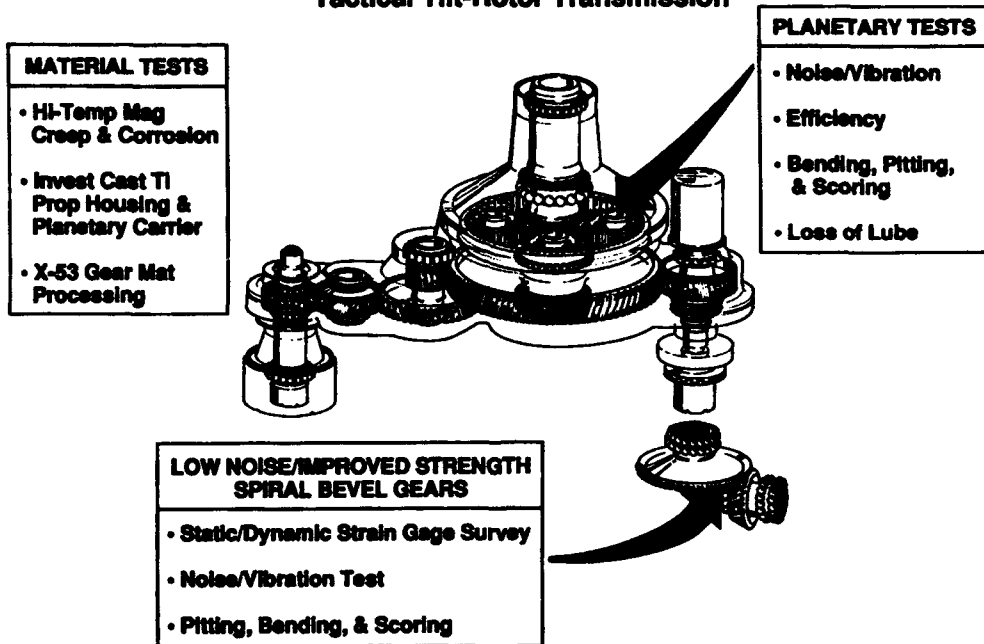

Figure 23.—Bell Helicopter Textron Inc. ART program component test plan.

## BOEING HELICOPTERS

### ADVANCED ROTORCRAFT TRANSMISSION (ART) PROJECT

Boeing Helicopters selected for their application the Future Air Attack Vehicle (FAAV). They defined their baseline as a tiltrotor aircraft and chose a helical three-stage planetary as their advanced technology configuration.

Based on the preliminary design and tradeoff studies, the ART program goals of weight, noise, and reliability are attainable. The 443 lb (24.6 percent) drivetrain weight reduction enables a 946 lb (5.5 percent) reduction in the aircraft's takeoff gross weight. For a fleet of 400 aircraft a \$116M cost savings is estimated due to the ART program research.

The testing planned by Boeing Helicopters also contains generic material testing and specific design related component testing. Gears made from Vasco X-2 high-temperature material and manufactured using near-net-shape forging will be tested. Lightweight accessory drive gears made from titanium with treated surfaces are also planned for testing. High-contact-ratio (HCR) gears which allow improved tooth load sharing for weight and noise reductions are to be tested. Boeing, jointly with NASA Lewis in the NASA Gear Noise Test Rig, will also be evaluating noise generation properties of eight parallel axis gear configurations. These include various HCR, noninvolute, helical, and double-helical gear types. Application of active force cancellation at the transmission mounts for noise control is being evaluated and will be tested on full-scale CH-47D transmission hardware at Boeing. Boeing has a substantial effort planned for hybrid bearing testing. Hybrid bidirectional tapered roller bearings are a key feature of their ART gearbox design. Cylindrical and ball-thrust hybrid bearings are also planned for testing. The hybrid bearing technology is aimed at allowing higher operating temperatures and producing greater reliability. By operating at higher temperatures, oil cooler system size can be reduced to save weight.

## ADVANCED ROTORCRAFT TRANSMISSION PROGRAM (BOEING HELICOPTERS)

### MILESTONES COMPLETED:

- DEFINED BASELINE & GROUND RULES
- CONSIDERED 8 CONFIGURATIONS (2 each)
  - SPLIT TORQUE
  - SELF-ALIGNING BEARINGLESS PLANETARY
  - PLANETARY
- SELECTED AN ALL HELICAL PLANETARY
- CONDUCTED COST ANALYSIS

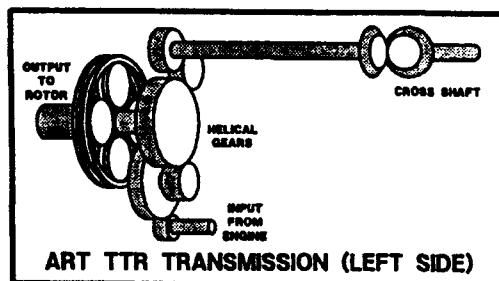
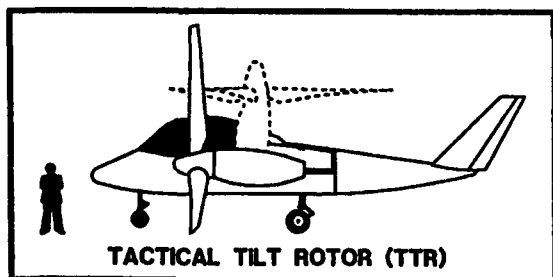

### SIGNIFICANCE:

- ART PROGRAM GOALS OF WEIGHT, NOISE, & RELIABILITY ATTAINABLE
- 443 lb DRIVE TRAIN WEIGHT REDUCTION YIELDS A 946 lb TOGW REDUCTION
- \$116 M AIRCRAFT COST SAVINGS DUE TO ART PROGRAM RESEARCH (400 A/C fleet)

Figure 24.—Boeing Helicopter ART program preliminary design.

## BOEING HELICOPTERS ART PROGRAM

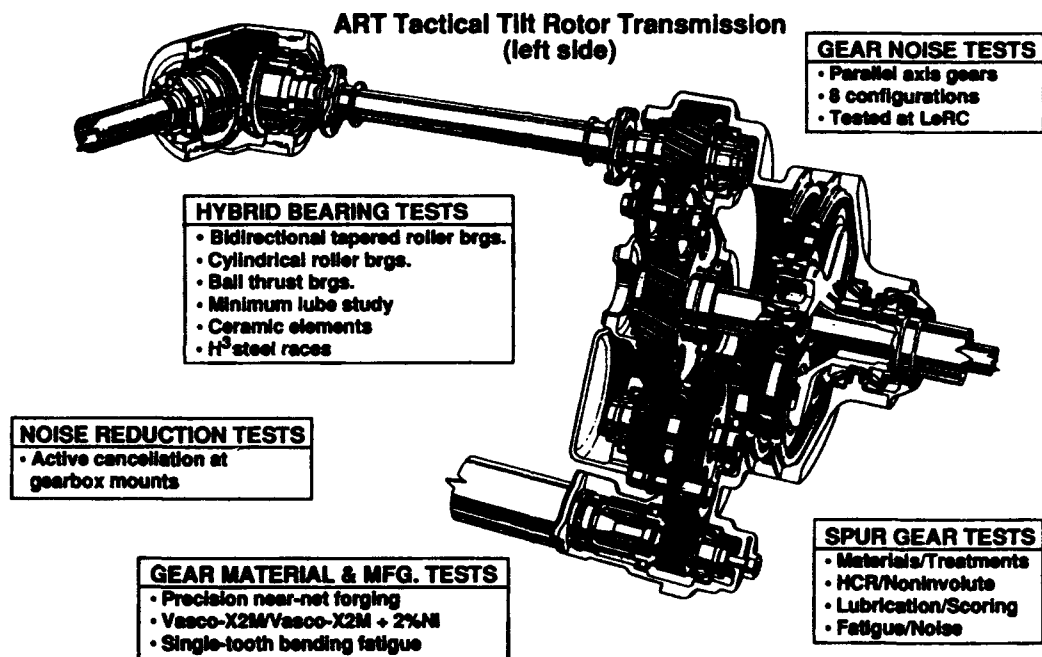

Figure 25.—Boeing Helicopter ART program component test plan.

## McDONNELL DOUGLAS HELICOPTER COMPANY

### ADVANCED ROTORCRAFT TRANSMISSION (ART) PROJECT

McDonnell Douglas Helicopter Company (MDHC) selected for their application the Future Air Attack Vehicle (FAAV). They defined their baseline as an upgraded AH-64 Apache helicopter and chose a split-torque transmission with face gears as their advanced technology configuration.

Based on the preliminary design and tradeoff studies, the ART program goals of weight, noise, and reliability are attainable. The split-torque transmission configuration with face gearing offers a large weight reduction benefit. The transmission weight reduction and life goals influence a significant cost savings in transmission acquisition and operating costs. For a fleet of 600 aircraft flying 25 years at 420 flight hours per year, a \$420M life cycle cost savings is estimated due to the ART program research.

The testing planned in support of the ART program varies from generic material testing to specific design related component testing. MDHC plans to perform single tooth bending tests, gear scoring tests, impact toughness tests, and fracture toughness tests for a variety of advanced materials. The gear materials are for next generation gearboxes and are high-temperature, high-strength steels (M50NiL, CBS 600, Maraging 300, and X-53). These materials will be compared to the baseline 9310 steel. All test specimens will be manufactured using advanced near-net-shape gear forging for improved strength and reduced manufacturing costs. MDHC also plans to perform basic tests on advanced magnesium and aluminum housing materials. Related to specific design concepts, MDHC plans on validation tests for face gears. Face gears were chosen by MDHC in the ART configuration as an alternative to spiral bevel gears. Face gears, however, have not yet been demonstrated in high-speed, high-load rotorcraft drivetrain applications. NASA Lewis and MDHC established a joint project to test face gears in the NASA Spiral Bevel Rig.

### ADVANCED ROTORCRAFT TRANSMISSION (ART) CONTRACT McDONNELL DOUGLAS HELICOPTER COMPANY

#### MILESTONES COMPLETED:

- BASELINE AIRCRAFT & TRANSMISSION DESIGN GROUND RULES DEFINED.
- TRANSMISSION CONFIGURATION TRADE-OFF STUDY COMPLETED. SPLIT-TORQUE CONFIGURATION CHOSEN.
- AIRCRAFT MISSION ANALYSIS COMPLETED.

#### FUTURE ATTACK ROTORCRAFT



#### SPLIT-TORQUE TRANSMISSION

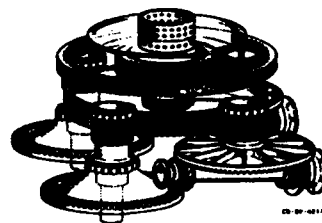

#### SIGNIFICANCE:

- ART GOALS OF WEIGHT, NOISE, & RELIABILITY ACHIEVABLE.
- SPLIT-TORQUE DESIGN OFFERS LARGE WEIGHT REDUCTION BENEFITS.
- TRANSMISSION ACQUISITION COSTS REDUCED BY 24%, DIRECT OPERATING COSTS REDUCED BY 33%.
- AIRCRAFT FLEET LIFE CYCLE COST SAVINGS OF \$420M.

Figure 26.—McDonnell Douglas Helicopter ART program preliminary design.

## McDONNELL DOUGLAS ART PROGRAM

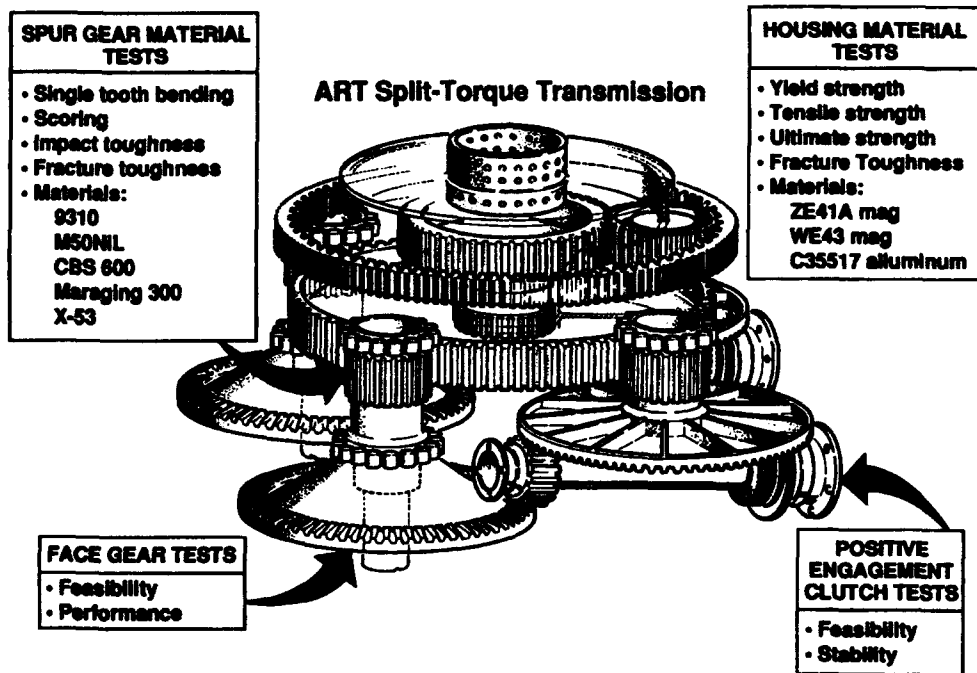

Figure 27.—McDonnell Douglas Helicopter ART program component test plan.

## SIKORSKY AIRCRAFT

### ADVANCED ROTORCRAFT TRANSMISSION (ART) PROJECT

Sikorsky Aircraft selected for their application the Advanced Cargo Aircraft (ACA). They defined as their baseline an upgraded CH-53 helicopter and chose a three-stage 11:1 ratio split torque as their advanced technology configuration.

The preliminary design along with the trade studies completed indicate that all ART program goals as they pertain to the Advanced Cargo Aircraft are attainable. The life cycle cost savings attributed to ART, assuming a fleet of 600 aircraft, a 240 flight hour utilization over a 35-year life cycle period, is estimated to be \$1.7 billion. Sixty-five percent of the savings is in operating costs and 35 percent in acquisition costs.

A major portion of the component validation planned by Sikorsky Aircraft will be performed utilizing a scaled-down version (one-half size) of the split-path transmission configuration proposed for the Advanced Cargo Aircraft. Included in the testing are the following: high-contact-ratio double-helical gears on the output stage, double-helical pinions with large gear tooth face width-to-diameter ratios, an elastomeric torque sharing device, topological gear tooth profiling for improved load distribution, high-temperature operation (300 °F), and scoring resistant X-53 gear material. Transmission error measurements will also be made. Each of the above items contribute to attaining the stated goals of the program. A separate bearing test will validate the performance of a hybrid angular contact/spherical roller bearing. The bearing has ceramic rolling elements, X-53 races, and silver plated steel cages. The tests will consist of various thrust and radial loads, speeds up to 14 000 rpm, and loss of lubrication. In addition, extensive use of weight-saving composite materials are being investigated for future testing. The applications are for the gearbox housing, main rotor quill shaft, engine input quill shafts, and the main rotor truss.

### ADVANCED ROTORCRAFT TRANSMISSION PROGRAM (SIKORSKY AIRCRAFT)

#### MILESTONES COMPLETED

- TRANSMISSION REQUIREMENTS AND CONCEPTS IDENTIFIED
- TRADE STUDIES/PRELIM. DESIGN
- AIRCRAFT SYSTEM ANALYSIS

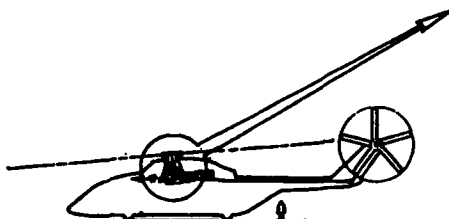

ADVANCED CARGO AIRCRAFT

#### 3 STAGE—11:1 SPLIT TORQUE

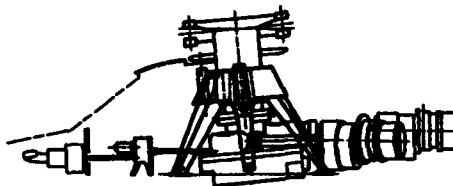

#### SIGNIFICANCE:

- PROGRAM GOALS FOR WEIGHT, NOISE, AND MTBR ATTAINABLE
- REDUCES TOTAL AIRCRAFT ACQUISITION COST BY \$1.187 M/AIRCRAFT
- REDUCES AIRCRAFT OPERATION COST BY \$349/FL-HR
- REDUCES FLEET LIFE CYCLE COSTS BY 1.7 BILLION

Figure 28.—Sikorsky Aircraft ART program preliminary design.

## SIKORSKY AIRCRAFT ART PROGRAM

### ART Split-Path Transmission

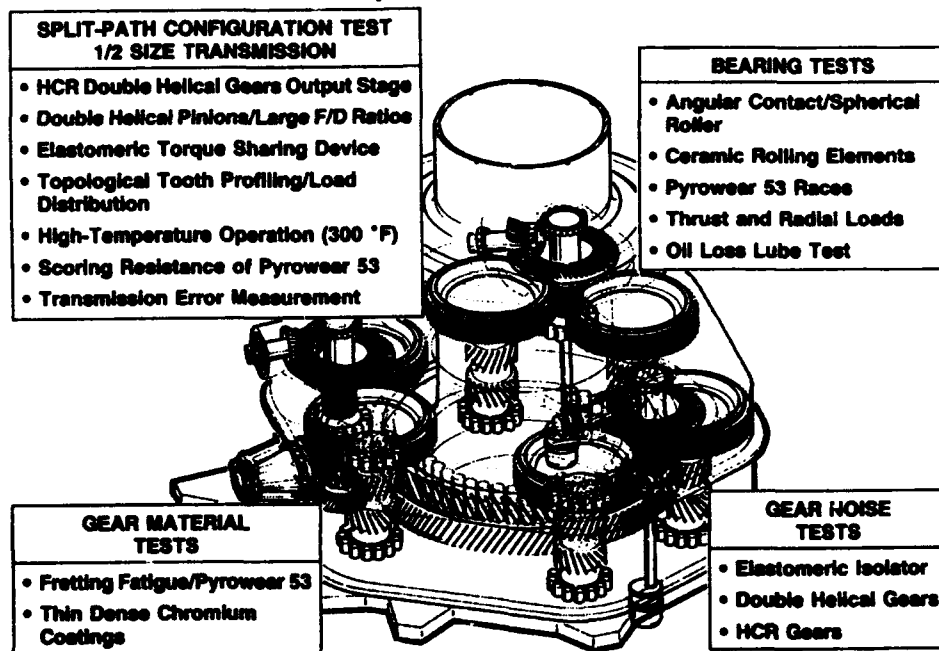

Figure 29.—Sikorsky Aircraft ART program component test plan.

## BIOGRAPHICAL SKETCH

Harold H. Coe

Mr. Harold H. Coe is currently a Senior Research Engineer in the Mechanical Systems Technology Branch at the NASA Lewis Research Center in Cleveland, Ohio. He joined the Flow Processes Branch at Lewis in 1960, and since 1965 has been concerned with analytical and experimental research on rolling element bearings operating at high speeds. Beginning in 1984 Mr. Coe has also been concerned with transmission research, performing efficiency tests and analytical thermal studies. He has been responsible for obtaining, updating, and utilizing several computer programs for the prediction of rolling element bearing thermal and kinematic performance. Recently Mr. Coe has been involved in developing optimization programs for gear and transmission design and serves as leader of the Branch Analytical Research Team. Mr. Coe has authored or co-authored over 45 reports. He has also managed a number of grants and contracts in the area of bearing and transmission research that have resulted in over 35 final contractor reports.

Mr. Coe received a BSME degree from Case Institute of Technology in 1955 and spent 5 years with Sandia Corporation before joining NASA.

Mr. Coe is a member of the STLE and Tau Beta Pi.



Mr. Harold H. Coe  
Senior Research Engineer  
Mechanical Systems Technology Branch  
NASA Lewis Research Center  
Mail Stop 77-10  
21000 Brookpark Road  
Cleveland, Ohio 44135

Phone (216) 433-3971  
Fax (216) 433-3954

## BIOGRAPHICAL SKETCH

William G. Costakis

Mr. William G. Costakis is employed by the NASA Lewis Research Center, Cleveland, Ohio. He joined NASA in 1963 as a research engineer in the Dynamics and Controls Branch of the Chemical Rockets Division. He has been performing experimental research in transmission and gears. He has been involved in gear noise research and parametric studies of the effects of different lubricant techniques on gear tooth temperature. Mr. Costakis has a BSEE degree from Youngstown University.



Mr. William G. Costakis  
Aerospace Technologist  
Mechanical Systems Technology Branch  
NASA Lewis Research Center  
Mail Stop 77-10  
21000 Brookpark Road  
Cleveland, Ohio 44135

Phone (216) 433-3965  
Fax (216) 433-3954

## BIOGRAPHICAL SKETCH

John J. Coy

Dr. John J. Coy is employed by the NASA Lewis Research Center, Cleveland, Ohio. He joined NASA in 1974 as a research engineer in the Bearing, Gearing and Transmission Section. Now as Branch Chief, Mechanical Systems Technology, he is managing research activities which are focused on gearing and drivetrains for advanced helicopters. Dr. Coy also serves as the coordinator of the vehicle focused R&T efforts in the rotorcraft and general aviation area for the NASA Lewis Aeronautics Directorate. He earned BS, MS, and PhD degrees in Mechanical Engineering at the University of Cincinnati and received the Distinguished Alumnus Award in 1987. A licensed professional engineer in Ohio, he is an active member of the American Society of Mechanical Engineers, Fellow of the ASME, past chairman of the ASME Power Transmission and Gearing Committee, and a past member of the NATO/AGARD Propulsion Energetics Panel. Author or co-author of over 80 technical papers, he has been on the faculty of Rose Hulman Institute of Technology, the University of Cincinnati, adjunct faculty member of Cleveland State University, and a consultant for industry and government agencies.



Dr. John J. Coy  
Chief, Mechanical Systems Technology Branch  
NASA Lewis Research Center  
Mail Stop 77-10  
21000 Brookpark Road  
Cleveland, Ohio 44135

Phone (216) 433-3915  
Fax (216) 433-3954

## BIOGRAPHICAL SKETCH

Harry J. Decker

Mr. Harry J. Decker is an Aerospace Engineer employed by the U.S. Army Research Laboratory's Vehicle Propulsion Directorate at the NASA Lewis Research Center, Cleveland, Ohio. He has been performing analytical and experimental research in transmission, gearing, and bearing areas for rotorcraft since 1988. He has performed various transmission and component experiments such as vibration, noise, temperature, and efficiency studies. He is also managing a contract relating to vibration diagnostics. Mr. Decker has earned a Bachelor of Mechanical Engineering degree from Cleveland State University and a BS in Aeronautical Engineering Technology from Kent State University.



Mr. Harry J. Decker  
Aerospace Engineer  
U.S. Army Research Laboratory  
Vehicle Propulsion Directorate  
NASA Lewis Research Center  
Mail Stop 77-10  
Office Symbol AMSRL-VP-T  
21000 Brookpark Road  
Cleveland, Ohio 44135

Phone (216) 433-3964  
Fax (216) 433-3954  
E-mail [toharry@lerc.nasa.gov](mailto:toharry@lerc.nasa.gov)

## BIOGRAPHICAL SKETCH

Robert F. Handschuh

Dr. Robert F. Handschuh has been employed by the U.S. Army Research Laboratory's Vehicle Propulsion Directorate at the NASA Lewis Research Center, Cleveland, Ohio since 1982. He has been involved in analytical and experimental work in gas path seals and power transmission. In the seals area he worked on high-temperature erosion of turbine shroud seals and blade-seal rub interaction. He holds a patent on an improved low thermal stress turbine shroud seal design. In the power transmission and gearing area he has been involved in planetary gear train efficiency, gear geometry, and spiral bevel gears. Recent projects have focused on spiral bevel gears from gear geometry grant activities to contract manufacturing programs. He has been responsible for in-house analysis development, grant activities, and an experimental facility for spiral bevel gear research. In these areas of research Mr. Handschuh has authored or co-authored over 20 technical papers. Mr. Handschuh has a BSME from Cleveland State University (1982), a MSME from University of Toledo (1987), and a Ph.D. from Case Western Reserve University (1993). He is a member of the American Society of Mechanical Engineers and is a member of the Power Transmission and Gearing Committee.



Dr. Robert F. Handschuh  
Aerospace Engineer  
U.S. Army Research Laboratory  
Vehicle Propulsion Directorate  
NASA Lewis Research Center  
Mail Stop 77-10  
Office Symbol AMSRL-VP-T  
21000 Brookpark Road  
Cleveland, Ohio 44135

Phone (216) 433-3969  
Fax (216) 433-3954

## BIOGRAPHICAL SKETCH

**Katsumi Inoue**

**Dr. Katsumi Inoue is an associate professor at Tohoku University, Japan. He received a Research Associateship Award of the National Research Council in 1990, and researched gearbox vibration while working in the Mechanical Systems Technology Branch, NASA Lewis Research Center (April 1990 to March 1991). He earned B.Eng., M.Eng., and Dr. Eng. degrees in Precision Engineering at Tohoku University, Japan. He has been an associate professor in the Department of Precision Engineering, Tohoku University since 1984. He is a member of the Japan Society of Mechanical Engineers, Japan Society of Precision Engineering, and Japan Society for Design Engineering.**



**Dr. Katsumi Inoue  
Research Associate of National Research Council  
Mechanical Systems Technology Branch  
NASA Lewis Research Center  
Mail Stop 77-10  
21000 Brookpark Road  
Cleveland, Ohio 44135**

**Phone (216) 433-3915  
Fax (216) 433-3954**

## **BIOGRAPHICAL SKETCH**

**Timothy L. Krantz**

Mr. Timothy L. Krantz is employed by the U.S. Army Research Laboratory's Vehicle Propulsion Directorate at the NASA Lewis Research Center, Cleveland, Ohio. He has been performing experimental and analytical research in gearing and transmission technology for rotorcraft applications since 1988. His research areas have included transmission efficiency, gear dynamics, spiral bevel gearing, planetary gear trains, and split torque gear trains. He has authored or co-authored 5 technical papers. He also manages contracts and grants relating to transmission research that have resulted in 6 technical publications. Mr. Krantz has earned a BSME from The University of Akron and a MSME from Cleveland State University.



**Mr. Timothy L. Krantz  
Aerospace Engineer  
U.S. Army Research Laboratory  
Vehicle Propulsion Directorate  
NASA Lewis Research Center  
Mail Stop 77-10  
Office Symbol AMSRL-VP-T  
21000 Brookpark Road  
Cleveland, Ohio 44135**

**Phone (216) 433-3580  
Fax (216) 433-3954**

## BIOGRAPHICAL SKETCH

David G. Lewicki

Mr. David G. Lewicki is employed by the U.S. Army Research Laboratory's Vehicle Propulsion Directorate at the NASA Lewis Research Center, Cleveland, Ohio. He has been performing analytical and experimental research in transmission, gearing, and bearing areas for rotorcraft and turboprop drivetrain applications since 1982. He has been involved in transmission life and reliability predictions as well as gear dynamics predictions. He has performed various transmission and component experiments such as vibration, noise, strain, deflection, temperature, efficiency, and configuration studies. He has also managed a variety of grants and contracts relating to transmission research. Mr. Lewicki has earned a MSME degree from the University of Toledo and a BSME degree from Cleveland State University. He is currently working toward completing his Ph.D. at Case Western Reserve University. He is a member of the American Society of Mechanical Engineers and is currently Associate Technical Editor for power transmission and gearing for the Journal of Mechanical Design.



Mr. David G. Lewicki  
Aerospace Engineer  
Mechanical Systems Technology Branch  
U.S. Army Research Laboratory  
Vehicle Propulsion Directorate  
NASA Lewis Research Center  
Mail Stop 77-10  
Office Symbol AMSRL-VP-T  
21000 Brookpark Road  
Cleveland, Ohio 44135

Phone (216) 433-3970  
Fax (216) 433-3954

## **BIOGRAPHICAL SKETCH**

**Fred B. Oswald**

**Mr. Fred B. Oswald is a research engineer working on gear stress, noise, and vibration in the Mechanical Systems Technology Branch at NASA Lewis Research Center, Cleveland, Ohio. He is the author or co-author of over 20 technical papers describing experimental and analytical research in the fields of gear and transmission dynamics, vibration, and noise. His experimental work involves measurements of vibration, strain, force, acoustics, temperature, and flow. Mr. Oswald has also managed grant and contract research efforts which complement in-house activity. Mr. Oswald holds an MS degree in Mechanical Engineering from the University of Toledo and a BME degree from Cleveland State University and is a registered Professional Engineer in the State of Ohio.**



**Mr. Fred B. Oswald  
Aerospace Engineer  
Mechanical Systems Technology Branch  
NASA Lewis Research Center  
Mail Stop 77-10  
21000 Brookpark Road  
Cleveland, Ohio 44135**

**Phone (216) 433-3957  
Fax (216) 433-3954**

## **BIOGRAPHICAL SKETCH**

### **Brian Rebbechi**

**Mr. Brian Rebbechi is a research engineer at the Australian Aeronautical Research laboratory. His research specialty is machine dynamics with particular interest in gear dynamic behavior, and vibration in helicopter transmissions and aircraft engines. Mr. Rebbechi holds a Bachelor of Engineering Degree from the University of Melbourne and Master of Engineering Science from Monash University. Mr. Rebbechi was a visiting scientist at NASA Lewis Research Center during 1989 and 1990.**

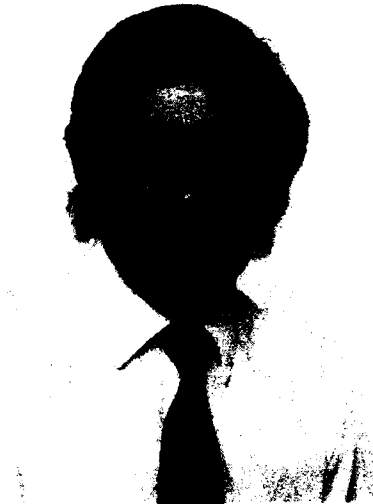

**Mr. Brian Rebbechi  
Senior Research Scientist  
Group Leader, Machine Dynamics  
Aeronautical Research Laboratory  
506 Lorimer Street  
Port Melbourne, Victoria 3207 Australia**

**Phone (216) 433-3915  
Fax (216) 433-3954**

## BIOGRAPHICAL SKETCH

Dennis P. Townsend

Mr. Dennis Townsend is employed by the NASA Lewis Research Center, Cleveland, Ohio. He joined NASA in 1962 as a research engineer in the Advanced Systems Division working on the space nuclear propulsion system. He has been performing research on power transmission bearing and gearing since 1966. He has been involved in transmission design and development of lubrication and cooling methods for gearing. He has conducted research on the evaluation of advanced lubricants, materials and design variables on gear life. He has worked with gear dynamic and noise analysis of transmission gearing. He has managed several contracts and grants related to gear dynamics, lubrication and transmission design. He is serving as the resident NASA and Army consultant on various aspects of transmission and gearing. He earned a BSME from West Virginia University. He is a fellow of the American Society of Mechanical Engineers (ASME) and has served as chairman of the Design Engineering Division of ASME. He is the editor of the Dudley Gear Handbook, 2nd Edition and has authored or co-authored over 105 publications.



Mr. Dennis P. Townsend  
Senior Research Engineer  
Mechanical Systems Technology Branch  
NASA Lewis Research Center  
Mail Stop 77-10  
21000 Brookpark Road  
Cleveland, Ohio 44135

Phone (216) 433-5771  
Fax (216) 433-3954

## BIOGRAPHICAL SKETCH

**Mark J. Valco**

**Dr. Mark J. Valco is employed by the U.S. Army Research Laboratory's Vehicle Propulsion Directorate which is colocated at the NASA Lewis Research Center in Cleveland, Ohio. Dr. Valco joined the Vehicle Propulsion Directorate in 1985 as an aerospace engineer. His work activities include analytical and experimental research in aviation propulsion systems with emphasis on lightweight rotorcraft mechanical drivetrains. He is involved with and manages university research grants and industrial contracted and cooperative research for rotorcraft drive systems. Dr. Valco earned the degrees Doctor of Engineering (1992), MSME (1984), and BSME (1982) earned at the Cleveland State University. His doctoral dissertation topic was the application of nonlinear finite element contact analysis methods to study gear meshing action and planetary gear trains. He is a member of the Army Aviation Association of America (AAAA).**



**Dr. Mark J. Valco  
Aerospace Engineer  
U.S. Army Research Laboratory  
Vehicle Propulsion Directorate  
NASA Lewis Research Center  
Mail Stop 77-10  
Office Symbol AMSRL-VP-T  
21000 Brookpark Road  
Cleveland, Ohio 44135**

**Phone (216) 433-3717  
Fax (216) 433-3954 or 3720  
E-mail aamark@scivax.lerc.nasa.gov**

## **BIOGRAPHICAL SKETCH**

**James J. Zakrajsek**

Mr. James J. Zakrajsek is employed by the NASA Lewis Research Center, Cleveland, Ohio. He joined NASA in 1987 and has been performing analytical and experimental research work in the areas of gear dynamics and noise predictions, and transmission diagnostics. He is currently team leader of the diagnostics group within the branch, and manages the research plans for the group. Mr. Zakrajsek serves as the NASA Focus Officer in the Aeronautics Technical Panel of The Technical Cooperation Program, in the areas of helicopter health monitoring, and on-line oil debris monitoring. He has also managed a number of grants and contracts in the area of gear and bearing dynamics predictions. Mr. Zakrajsek earned MS and BS degrees in Mechanical Engineering from Cleveland State University. He is currently an adjunct faculty member in the College of Engineering at Cleveland State University. Prior to joining NASA, Mr. Zakrajsek worked at VME Americas Inc. as a Senior Design Engineer, and was responsible for all aspects of the engines and transmissions for the entire product line.



**Mr. James J. Zakrajsek**  
**Aerospace Engineer**  
**Mechanical Systems Technology Branch**  
**NASA Lewis Research Center**  
**Mail Stop 77-10**  
**21000 Brookpark Road**  
**Cleveland, Ohio 44135**

**Phone (216) 433-3968**  
**Fax (216) 433-3954**

## BIBLIOGRAPHY

- Akin, L.S. and Townsend, D.P.: Into-Mesh Lubrication of Spur Gears with Arbitrary Offset Oil Jet-Part 1, *Gear Technology*, Vol. 6, No. 3, pp. 30-48, May/June, 1989.
- Akin, L.S. and Townsend, D.P.: Into-Mesh Lubrication of Spur Gears, Part 2, *Gear Technology*, Vol. 6, No. 4, pp. 26-33, July/Aug. 1989.
- Akin, L.S. and Townsend, D.P.: Lubricant Jet Flow Phenomena In Spur and Helical Gears, *Gear Technology*, Vol. 4, No.1, pp. 10-20, Jan./Feb. 1987.
- Akin, L.S. and Townsend, D.P.: Lubricant Jet Flow Phenomena in Spur and Helical Gears with Modified Addendums—For Radially Directed Individual Jets, NASA TM-101460, AVSCOM TR 88-C-034, Presented at Fifth International Power Transmissions and Gearing Conference, ASME, Chicago, Apr. 25-28, 1989, in Proceedings of the 1989 International Power Transmission and Gearing Conference, ASME, New York, Vol. 1, pp. 367-374, 1989.
- Akin, L.S. and Townsend, D.P.: Lubricant Jet Flow Phenomena in Spur and Helical Gears With Modified Center Distances and/or Addendums—For Out-of-Mesh Conditions, *Journal of Mechanisms Transmissions and Automation in Design*, Vol. 107, No. 1, pp. 24-30, Mar. 1985.
- Akin, L.S. and Townsend, D.P.: Wear Consideration in Gear Design for Space Applications, NASA TM-101457, AVSCOM TR 88-C-033, Presented at Fifth International Power Transmission and Gearing Conference, ASME, Chicago, Apr. 25-28, 1989, in Proceedings of the 1989 International Power Transmission and Gearing Conference, ASME, New York, Vol. 1, pp. 361-365, 1989.
- Altidus, P.C. and Savage, M: Flexibility Effects on Tooth Contact Location in Spiral Bevel Gear Transmissions, NASA CR-4055, Mar. 1987.
- Armstrong, E.S. and Coe, H.H.: Computer-Aided Design Analysis of 57-mm, Angular-Contact, Cryogenic Turbopump Bearings, NASA TP-2816, Mar. 1988.
- Atherton, W.J., Pintz, A. and Lewicki, D.G.: Automated Acoustic Intensity Measurements and the Effect of Gear Tooth Profile on Noise, NASA TM-100155, AVSCOM TR 87-C-24, presented at ASME Vibrations Conference, Sept. 27-30, 1987.
- Bamberger, E.N. and Nahm, A.H.: Improved Fracture Toughness Corrosion Resistant Bearing Material, NASA CR-174990, Jan. 1986.
- Bassett, D.E. and Houser, D.R.: The Design and Analysis of Single Flank Transmission Error Tester for Loaded Gears, NASA CR-179621, AVSCOM TR 87-C-15, June 1987.
- Bibel, G.D., Reddy, S.K., Savage, M., and Handschuh, R.F.: Effects of Rim Thickness on Spur Gear Bending Stress, NASA TM-104388, AVSCOM TR 91-C-015, AIAA paper 91-2020, presented at AIAA/SAE/ASME/ASEE 27th Joint Propulsion Conference, Sacramento, June 24-27, 1991.
- Bill, R.C., Weden, G.J., and Coy, J.J.: An Overview of Rotorcraft Propulsion Research at Lewis Research Center, *Vertiflite*, Vol. 34, No. 3, pp. 24-31, May/June 1988.

**Bosler, R. and Heath, G.:** Advanced Rotorcraft Transmission (ART) Program Status, presented at the Rotary Wing Propulsion Specialists' Meeting Sponsored by the Hampton Roads Chapter Southeast Region American Helicopter Society, AHS Preprint No. 4, Williamsburg, Virginia, Nov. 13-15, 1990.

**Bosler, R.B. and Heath, G.F.:** Advanced Rotorcraft Transmission (ART) Program Status, AIAA paper 91-1906, presented at AIAA/SAE/ASME/ASEE 27th Joint Propulsion Conference, Sacramento, June 24-27, 1991.

**Bosler, Jr., R.B. and Heath G.F.:** Advanced Rotorcraft Transmission Program Summary, AIAA-92-3363, Presented at AIAA/SAE/ASME/ASEE 28th Joint Propulsion Conference, Nashville, TN, July 6-8, 1992.

**Boyd, L.S.:** Two Stage Gear Tooth Dynamics Program, NASA CR-185110, AVSCOM TM 89-C-003, Aug. 1989.

**Boyd, L.S. and Pike, J.:** Expansion of Epicyclic Gear Dynamic Analysis Program, NASA CR 179563, Aug. 1986.

**Brown, J.:** Gear Tooth Modifications Reduce Loads, Power Transmission Design, Vol. 31, No. 8, pp. 45-48, Aug. 1989.

**Chang, S.H. and Huston, R.L.:** Computer Aided Design and Analysis of Gear Tooth Geometry, NASA CR-179611, AVSCOM TR 87-C-13, May 1987.

**Chang, S.H., Huston, R.L., and Coy, J.J.:** Computer-Aided Design of Bevel Gear Tooth Surfaces, NASA TM-101449, AVSCOM TM 88-C-005, Presented at Fifth International Power Transmission and Gearing Conference, ASME, Chicago, Apr. 25-28, 1989, in Proceedings of the 1989 International Power Transmission and Gearing Conference, ASME, New York, Vol. 2, pp. 585-591, 1989.

**Chao, H.C. and Cheng, H.S.:** A Computer Solution for the Dynamic Load, Lubricant Film Thickness, and Surface Temperatures in Spiral Bevel Gears, NASA CR-4077, AVSCOM TR 87-C-17, July 1987.

**Choy, F.K., Ruan, Y.F., Tu, Y.K., Zakrajsek, J.J. and Townsend, D.P.:** Modal Analysis of Multistage Gear Systems Coupled With Gearbox Vibrations, NASA TM-103797, AVSCOM TR 90-C-033, presented at the International Conference on Motion and Power Transmissions, JSME/ASME/I.Mech.E/VDI/IET/CSME and other societies, Hiroshima, Japan, Nov. 24-26, 1991.

**Choy, F.K., Ruan, Y.F., Zakrajsek, J.J., Oswald, F.B., and Coy, J.J.:** Analytical and Experimental Study of Vibrations in a Gear Transmission, NASA TM-104434, AVSCOM TR 90-C-032, AIAA-91-2019, presented at AIAA/SAE/ASME/ASEE 27th Joint Propulsion Conference, Sacramento, June 24-27, 1991.

**Choy, F.K., Ruan Y.F., Zakrajsek, J.J., Townsend, D.P., Oswald, F.B., and Decker, H.J.:** Modal Simulation of Gearbox Vibration With Experimental Correlation, NASA TM-105702, AVSCOM TR 92-C-018, AIAA-92-3494, Presented at AIAA/SAE/ASME/ASEE 28th Joint Propulsion Conference, Nashville, TN, July 6-8, 1992.

**Choy, F.K., Townsend, D.P., and Oswald, F.B.:** Dynamic Analysis of Multimesh-Gear Helicopter Transmission, NASA TP-2789, Feb. 1988.

**Choy, F.K., Townsend, D.P., and Oswald, F.B.: Experimental and Analytical Evaluation of Dynamic Load Vibration of a 2240-kW (3000-hp) Rotorcraft Transmission, NASA TM-88975, presented at the ASME Design Engineering Conference, Chicago, Mar. 2-5, 1987.**

**Choy, F.K., Tu, Y.K., Savage, M., and Townsend, D.P.: Vibration Signature Analysis of Multistage Gear Transmission, NASA TM-101442, AVSCOM TR 88-C-040, Presented at Fifth International Power Transmission and Gearing Conference, ASME, Chicago, Apr. 25-28, 1989, in Proceedings of the 1989 International Power Transmission and Gearing Conference, ASME, New York, Vol. 1, pp. 383-390, 1989.**

**Choy, F.K., Tu, Y.K., Zakrajsek, J.J., and Townsend, D.P.: Dynamics of Multistage Gear Transmission With Effects of Gearbox Vibrations, NASA TM-103109, AVSCOM TR 90-C-022, presented at the CSME Mechanical Engineering Forum 1990, Toronto, Canada, June 3-9, 1990.**

**Choy, F.K., Tu, Y.K., Zakrajsek, J.J. and Townsend, D.P.: Effects of Gear Box Vibration and Mass Imbalance on the Dynamics of Multi-Stage Gear Transmissions, NASA TM-103695, AVSCOM TR 90-C-022, Mar. 1991.**

**Coe, H.H.: Comparison of Predicted and Measured Temperatures of UH-60A Helicopter Transmission, NASA TP-2911, AVSCOM TR 89-C-010, Apr., 1989.**

**Coe, H.H.: Spur-Gear Optimization Using SPUROPT Computer Program, NASA TM-104394, AVSCOM TR 90-C-014, Sept. 1991.**

**Coe, H.H.: Thermal Analysis of a Planetary Transmission With Spherical Roller Bearings Operating After Complete Loss of Oil, NASA TP-2367, Sept. 1984.**

**Coe, H.H. and Zaretsky, E.V.: Effect of Interference Fits on Roller Bearing Fatigue Life, NASA TM-87165, Jan. 1986.**

**Coe, H.H. and Zaretsky, E.V.: Effect of Speed and Press Fit on Fatigue Life on Roller-Bearing Inner-Race Contact, NASA TP-2496, July 1985.**

**Coy, J.J.: Geared Power Transmission Technology, Chapter 1 of Gear Design Manufacturing and Inspection Manual, Society of Automotive Engineers, Warrendale, PA, pp. 5-13, Jan. 1990.**

**Coy, J.J.: Rotorcraft Transmissions, presented at Aeropropulsion 1987 Conference, published in Aeropropulsion '87, Session 5 - Subsonic Propulsion Technology, NASA CP-10003, pp. 5-49 to 5-57, Nov. 1987.**

**Coy, J.J. and Bill, R.C.: Advanced Transmission Studies, NASA TM 100867, AVSCOM TR 88-C-002, presented at 44th Annual Forum of the American Helicopter Society, Washington DC, June 16-18, 1988.**

**Coy, J.J. and Eisenberg, J.D.: Overview of Rotorcraft and General Aviation Propulsion Technology, Aeropropulsion '91, NASA CP-10063, pp. 26-1 to 26-13, Mar. 1991.**

**Coy, J.J., Handschuh, R.F., Lewicki, D.G., Huff, R.G., Krejsa, E.A. and Karchmer, A.M.: Identification and Proposed Control of Helicopter Transmission Noise at the Source, USAAVSCOM-TR-87-C-2, presented at NASA/Army Rotorcraft Technology Conference, Ames Research Center, Mar. 17-19, 1987.**

Coy, J.J., Handschuh, R.F., Lewicki, D.G., Huff, R.G., Krejsa, E.A. and Karchmer, A.M.: Identification and Proposed Control of Helicopter Transmission Noise at the Source, USAAVSCOM-TR-87-C-2, presented at NASA/Army Rotorcraft Technology Conference, Ames Research Center, Mar. 17-19, 1987.

Coy, J.J., Mitchell, A.M. and Hamrock, B.J.: Transmission Efficiency Measurements and Correlations With Physical Characteristics of the Lubricant, NASA TM-83740, USAAVSCOM TR 84-C-11, presented at the 64th Symposium of the Propulsion and Energetics Panel on Gears and Transmission Systems for Helicopters and Turboprops, sponsored by AGARD, Lisbon, Portugal, Oct. 8-12, 1984.

Coy, J.J., Townsend, D.P. and Coe, H.H.: Results of NASA/Army Transmission Research, NASA CP-2495, USAAVSCOM, TR-87-C-3, presented at NASA/Army Rotorcraft Technology Conference, Ames Research Center, Mar. 17-19, 1987.

Coy, J.J., Townsend, D.P., Lewicki, D.G., and Coe, H.H.: Helicopter Transmission Research at NASA Lewis Research Center, NASA TM-100962, AVSCOM TR 88-C-003, presented at the International Conference on Gearing sponsored by the Chinese Mechanical Engineering Society, Zhengzhou, China, Nov. 5-10, 1988.

Coy, J.J., Townsend, D.P., and Zaretsky, E.V.: Gearing, NASA RP-1152, AVSCOM TR 84-C-15, Dec. 1985.

El-Bayoumy, L.E., Akin, L.S., and Townsend, D.P.: An Investigation of the Transient Thermal Analysis of Spur Gears, *Journal of Mechanisms, Transmissions, and Automation in Design*, Vol. 107, pp. 541-548, Dec. 1985.

El-Bayoumy, L.E., Akin, L.S., and Townsend, D.P.: Parameter Studies of Gear Cooling Using An Automatic Finite Element Mesh Generator, ASME paper 84-DET-155, presented at the 4th International Power Transmission and Gearing Conference, Cambridge, MA, Oct. 10-12, 1984.

El-Bayoumy, L.E., Akin, L.S., Townsend, D.P., and Choy, F.C.: The Role of Thermal and Lubricant Boundary Layers in the Transient Thermal Analysis of Spur Gears, NASA TM-101435, AVSCOM TR 88-C-032, Presented at Fifth International Power Transmission and Gearing Conference, ASME, Chicago, Apr. 25-28, 1989, in Proceedings of the 1989 International Power Transmission and Gearing Conference, ASME, New York, Vol. 1, pp. 313-325, 1989.

Flanagan, P.M. and Atherton, W.J.: Investigation on Experimental Techniques to Detect, Locate, and Quantify Gear Noise in Helicopter Transmissions, NASA CR-3847, Jan. 1985.

Folenta, D. and Lebo, W.: Design, Manufacture, and Spin Test of High Contact Ratio Helicopter Transmission Utilizing Self-aligning Bearingless Planetary (SABP), NASA CR-4155, AVSCOM TR 88-C-009, June 1988.

Frint, H.: Automated Inspection and Precision Grinding of Spiral Bevel Gears, NASA CR-4083, AVSCOM TR 87-C-11, July 1987.

Frint, H.K.: Design and Evaluation of High Contact Ratio Gearing, NASA CR-174958, July 1986.

Frint, H.K. and Glasow, W.: Enhanced Automated Spiral Bevel Gear Inspection, NASA CR-189125, AVSCOM TR 91-C-048, Mar. 1992.

**Handschuh, R.F.: An Exponential Finite Difference Technique for Solving Partial Differential Equations, NASA TM-89874, AVSCOM TR 87-C-19, June 1987.**

**Handschuh, R.F.: Effect of Lubricant Jet Location on Spiral Bevel Gear Operating Temperatures, NASA TM-105656, AVSCOM TR 91-C-033, ASME publication DE-Vol. 43-1, pp. 275-282, Presented at ASME 6th Int. Power Transmission and Gearing Conference, Scottsdale, AZ, Sept. 13-16, 1992.**

**Handschuh, R.F.: High-Temperature Erosion of Plasma-Sprayed, Yttria-Stabilized Zirconia in a Simulated Turbine Environment, NASA TP2795-2406, AVSCOM TR 84-C-17, Dec. 1984.**

**Handschuh, R.F.: Thermal Stress Analysis of a New Turbine Shroud Seal Concept, NASA TM-87082, USAAVSCOM TR 85-C-16, Aug. 1985.**

**Handschuh, R.F. and Bill, R.C.: Recent Manufacturing Advances for Spiral Bevel Gears, NASA TM-104479, AVSCOM TR 91-C-022, presented at SAE Aerotech '91 meeting, Long Beach, Sept. 23-26, 1991.**

**Handschuh, R.F. and Keith, T.G. Jr.: Applications of an Exponential Finite Difference Technique, NASA TM-100939, AVSCOM TM 88-C-004, July 1988.**

**Handschuh, R.F., Lewicki, D.G., and Bossler, Jr., R.B.: Experimental Testing of Prototype Face Gears for Helicopter Transmissions, NASA TM-105434, AVSCOM TR 92-C-008, Presented at Gearbox Configurations of the 90's, IMechE, Solihull, West Midlands, UK, Oct. 28, 1992.**

**Handschuh, R.F. and Litvin, F.L.: A Method for Determining Spiral-Bevel Gear Tooth Geometry for Finite Element Analysis, NASA TP-3096, AVSCOM TR 91-C-020, Aug. 1991.**

**Handschuh, R.F. and Litvin, F.L.: How to Determine Spiral Bevel Gear Tooth Geometry for Finite Element Analysis, NASA TM-105150, AVSCOM TR 91-C-018, the International Conference on Motion and Power Transmissions, JSME/ASME/I.Mech.E/VDI/IET/CSME and other societies, Hiroshima, Japan, Nov. 24-26, 1991.**

**Handschuh, R.F. and Rohn, D.A.: Efficiency Testing of a Helicopter Transmission Planetary Reduction Stage, NASA TP-2795, AVSCOM TR 87-C-28, Presented at Fifth International Power Transmission and Gearing Conference, ASME, Chicago, Apr. 25-28, 1989, in Proceedings of the 1989 International Power Transmission and Gearing Conference, ASME, New York, Vol. 1, pp. 243-257, 1989.**

**Henry, Z.S.: Advanced Rotorcraft Transmission (ART)—Component Test Results, AAIA 92-3366, Presented at AIAA/SAE/ASME/ASEE 28th Joint Propulsion Conference, Nashville, TN, July 6-8, 1992.**

**Henry, Z.S.: Preliminary Design and Analysis of an Advanced Rotorcraft Transmission, AIAA paper 91-2018, presented at AIAA/SAE/ASME/ASEE 27th Joint Propulsion Conference, Sacramento, June 24-27, 1991.**

**Henry, Z.S.: Preliminary Design and Analysis of an Advanced Rotorcraft Transmission, presented at the Rotary Wing Propulsion Specialists' Meeting Sponsored by the Hampton Roads Chapter Southeast Region American Helicopter Society, AHS Preprint No. 3, Williamsburg, Virginia, Nov. 13-15, 1990.**

**Hochmann, D., Smith, D., Thomas, J. and Houser, D.R.: Transmission Error and Load Distribution Analysis of Spur and Double Helical Gear Pair Used in a Split Path Helicopter Transmission Design, presented at AHS Technical Specialists Meeting, Philadelphia, Oct. 15-16, 1991.**

**Howe, D.C., Sundt, C.V., and McKibbin, A.H.: Advanced Gearbox Technology, NASA CR-180883, Oct. 1988.**

**Hsieh, C-M., Huston, R.L., and Oswald, F.B.: Contact Stresses in Meshing Spur Gear Teeth: Use of an Incremental Finite Element Procedure, NASA TM-105388, AVSCOM TR 90-C-029, Mar. 1992.**

**Hsu, C.Y. and Cheng, H.S.: A Simplified Computer Solution for the Flexibility Matrix of Contacting Teeth for Spiral Bevel Gears, NASA CR-179620, AVSCOM TR 87-C-16, June 1987.**

**Huston, R.L. and Coy, J.J.: Pressure Angle Changes in the Transverse Plane for Circular Cut Spiral Bevel Gears, Gear Technology, Vol. 3, No. 5, pp. 42-48, Sept./Oct. 1986.**

**Huston, R.L., Mavriplis, D., and Oswald, F.B.: Computer Aided Design of Spur Gear Teeth, Presented at Fifth International Power Transmission and Gearing Conference, ASME, Chicago, Apr. 25-28, 1989, in Proceedings of the 1989 International Power Transmission and Gearing Conference, ASME, New York, Vol. 2, pp. 539-545, 1989.**

**Huston, R.L., Mavriplis, D., Oswald, F.B., and Liu, Y.S.: A Basis for Solid Modeling of Gear Teeth With Application in Design and Manufacture, NASA TM-105392, AVSCOM TR 91-C-044, Apr. 1992.**

**Inoue, K., Townsend, D.P., and Coy, J.J.: Minimization of the Vibration Energy of Thin-Plate Structure, NASA TM-105654, AVSCOM TR 91-C-028, ASME Publication DE-Vol. 44-2, pp. 369-376, Presented at ASME 1992 Design Automation Conference, Phoenix, AZ, Sept. 13-16, 1992.**

**Inoue, K., Townsend, D.P., and Coy, J.J.: Optimum Design of a Gearbox for Low Vibration, NASA TM-105653, AVSCOM TR 91-C-027, ASME publication DE-Vol. 43-2, pp. 497-504, Presented at ASME 6th Int. Power Transmission and Gearing Conference, Scottsdale, AZ, Sept. 13-16, 1992.**

**Kahraman A., Ozguven, H.N., Houser D.R., and Zakrajsek, J.J.: Dynamic Analysis of Geared Rotors by Finite Elements, NASA TM-102349, AVSCOM TM 89-C-006, Jan. 1990.**

**Kish, J.: Advanced Rotorcraft Transmission (ART) Program Review, presented at the Rotary Wing Propulsion Specialists' Meeting Sponsored by the Hampton Roads Chapter Southeast Region American Helicopter Society, AHS Preprint No. 5, Williamsburg, Virginia, Nov. 13-15, 1990.**

**Kish, J.: Advanced Rotorcraft Transmission (ART)—Program Status, AIAA paper 91-1909, presented at AIAA/SAE/ASME/ASEE 27th Joint Propulsion Conference, Sacramento, June 24-27, 1991.**

**Kittur, M.G. and Huston, R.L.: Mesh Refinement in Finite Element Analysis by Minimization of the Stiffness Matrix Trace, NASA CR-185170, AVSCOM TR 89-C-019, Nov. 1989.**

**Kittur, M.G., Huston, R.L., and Oswald, F.B.: Finite-Element Grid Improvement by Minimization of Stiffness Matrix Trace, NASA TM-100255, AVSCOM TR 87-C-4, Dec. 1987.**

**Kittur, M.G., Huston, R.L., and Oswald, F.B.: Improvement in Finite Element Meshes: Heat Transfer in an Infinite Cylinder, NASA TM-101410, AVSCOM TR 88-C-021, Dec. 1988.**

**Krantz, T.L.: Experimental and Analytical Evaluation of Efficiency of Helicopter Planetary Stage, NASA TP-3063, AVSCOM TR 90-C-001, Nov. 1990.**

**Krantz, T.L.: Gear Tooth Stress Measurements of Two Helicopter Planetary Stages, NASA TM-105651, AVSCOM TR 91-C-038, ASME publication DE-Vol. 43-1, pp. 59-66, Presented at ASME 6th Int. Power Transmission and Gearing Conference, Scottsdale, AZ, Sept. 13-16, 1992.**

**Krantz, T.L. and R.F. Handschuh: Efficiency Study Comparing Two Helicopter Planetary Reduction Stages, NASA TM-103106, AVSCOM TM 90-C-005, presented at the 26th Joint Propulsion Conference, AIAA/SAE/ASME/ASEE, Orlando, FL, July 16-18, 1990.**

**Krantz, T.L. and Kish, J.G.: Advanced Rotorcraft Transmission (ART) Program Summary, NASA TM-105665, AVSCOM TR 92-C-011, AIAA-92-3365, Presented at AIAA/SAE/ASME/ASEE 28th Joint Propulsion Conference, Nashville, TN, July 6-8, 1992.**

**Krantz, T.L., Rashidi, M., and Kish, J.G.: Split Torque Transmission Load Sharing, NASA TM-105884, AVSCOM TR 92-C-030, Presented at Gearbox Configurations of the 90's, IMechE, Solihull, West Midlands, UK, Oct. 28, 1992.**

**Kreider, G.E. and Dressler, G.J.: Preliminary Screening Study of P/M Materials for Improved Oil-Off Survivability of Tapered Roller Bearings, NASA CR-174770, Oct. 1984.**

**Kreider, G.E. and Lee, P.W.: Improved Oil-Off Survivability of Tapered Roller Bearings. NASA CR-180804, AVSCOM TR 87-C-29, Oct. 1987.**

**Lee, C., Lin, H.H., Oswald, F.B., and Townsend, D.P.: Influence of Linear Profile Modification and Loading Conditions on the Dynamic Tooth Load and Stress of High Contact Ratio Gears, NASA TM-103136, AVSCOM TM 90-C-004, presented at ASME Mechanisms Conference, Chicago, Sept. 16-19, 1990.**

**Lenski, J.W.: Boeing Helicopters Advanced Rotorcraft Transmission (ART) Program Status, presented at the Rotary Wing Propulsion Specialists' Meeting Sponsored by the Hampton Roads Chapter Southeast Region American Helicopter Society, AHS Preprint No. 2, Williamsburg, Virginia, Nov. 13-15, 1990.**

**Lenski, J.W. and Valco, M.J.: Advanced Rotorcraft Transmission (ART) Program—Boeing Helicopters Status Report, NASA TM-104474, AVSCOM TR 91-C-032, presented at AIAA/SAE/ASME/ASEE 27th Joint Propulsion Conference, Sacramento, June 24-27, 1991.**

**Lewicki, D.G.: Advanced Rotorcraft Transmission Technology, Aeropropulsion '91, NASA CP-10063, pp. 29-1 to 29-15, Mar. 1991.**

**Lewicki, D.G.: Predicted Effect of Dynamic Load on Pitting Fatigue Life for Low-Contact-Ratio Spur Gears, NASA TP-2610, AVSCOM TR-86-C-21, June 1986.**

**Lewicki, D.G.: Transmission Research Activities at NASA Lewis Research Center, NASA TM-103132, AVSCOM TM 90-C-006, presented at the Helicopter Transmissions Design and Maintenance Workshop, Canadian Department of National Defense, Quebec City, May 21-25, 1990.**

**Lewicki, D.G., Black, J.D., Savage, M., and Coy, J.J.: Fatigue Life Analysis of a Turboprop Reduction Gearbox, NASA TM-87014, USAAVSCOM TR 84-C-4, presented at ASME Design Technical Conference, Cincinnati, Sept. 11-13, 1985.**

**Lewicki, D.G., Blanchette, D.M., and Biron, G.: Evaluation of an Oil-Debris Monitoring Device for Use in Helicopter Transmissions, NASA TM-105830, AVSCOM TR 92-C-007, Aug. 1992.**

**Lewicki, D.G. and Coy, J.J.: Helicopter Transmission Testing at NASA Lewis Research Center, NASA TM-89912, AVSCOM TR 87-C-10, presented at Testing Aerospace Transmissions Conference, sponsored by IMECHE, Derby, England, June 10, 1987.**

**Lewicki, D.G. and Coy, J.J.: Vibration Characteristics of the OH-58A Helicopter Main Rotor Transmission, NASA TP-2705, USAAVSCOM TR 86-C-42, Apr. 1987.**

**Lewicki, D.G., Decker, H.J., and Shimski, J.T.: Development of a Full-Scale Transmission Testing Procedure To Evaluate Advanced Lubricants, NASA TP-3265, AVSCOM TR 91-C-026, Aug. 1992.**

**Lewicki, D.G., Decker, H.J., and Shimski, J.T.: Full-Scale Transmission Testing to Evaluate Advanced Lubricants, NASA TM-105668, AVSCOM TR 91-C-035, ASME publication DE-Vol. 43-1 pp. 291-297, Presented at ASME 6th Int. Power Transmission and Gearing Conference, Scottsdale, AZ, Sept. 13-16, 1992.**

**Lewicki, D.G. and Townsend, D.P.: Effect of Advanced Component Technology on Helicopter Transmissions, NASA TM-101431, AVSCOM TR 87-C38, Presented at Fifth International Power Transmission and Gearing Conference, ASME, Chicago, Apr. 25-28, 1989, in Proceedings of the 1989 International Power Transmission and Gearing Conference, ASME, New York, Vol. 1, pp. 267-279, 1989.**

**Lim, T.C. and Singh, R.: A Review of Gear Housing Dynamics and Acoustics Literature, NASA CR-185148, AVSCOM TM 89-C-009, Oct. 1989.**

**Lim, T.C., Singh, R., and Zakrajsek, J.J.: Modal Analysis of Gear Housing and Mounts, NASA TM-101445, AVSCOM TR 88-C-041, Presented at the Seventh International Modal Analysis Conference, Las Vegas, Jan. 30-Feb. 2, 1989. In proceedings of the 7th International Modal Analysis Conference, Union College, Schenectady, NY, and Soc. Exp. Mech., Bethel, CT, Vol. II, pp. 1072-1078, 1989.**

**Lin, E.H.-H., Huston, R.L., and Coy, J.J.: On Dynamic Loads in Parallel Shaft Transmissions, 1: Modelling and Analysis, NASA TM-100180, AVSCOM TM-87-C-2, Dec. 1987.**

**Lin, E.H.-H., Huston, R.L., and Coy, J.J.: On Dynamic Loads in Parallel Shaft Transmissions, 2: Parameter Study, NASA TM-100181, AVSCOM TM-87-C-3, Dec. 1987.**

**Lin, H.H., Huston, R., and Coy, J.J.: Dynamic Analysis of Straight and Involute Tooth Forms, Gear Technology, Vol. 2, No. 4, pp. 6-23, July/Aug. 1985.**

Lin, H.-H. and Huston, R.L.: Dynamic Loading on Parallel Shaft Gears, NASA CR-179473, July 1986.

Lin, H.H., Townsend, D.P., and Oswald, F.B.: Profile Modification to Minimize Spur Gear Dynamic Loading, NASA TM-89901, presented at ASME Design Engineering Technical Conference, Orlando, Sept. 24-28, 1988.

Lin, H.H., Lee, C., Oswald, F.B., and Townsend, D.P.: Computer-Aided Design of High Contact-Ratio Gears for Minimum Dynamic Load and Stress, NASA TM-103275, AVSCOM TR 90-C-016, prepared for the Design Productivity International Conference sponsored by the ASME, Honolulu, HI, Feb. 6-8, 1991.

Lin, H.H., Oswald, F.B. and Townsend, D.P.: Dynamic Loading of Spur Gears With Linear or Parabolic Tooth Profile Modifications, NASA TM-101444, AVSCOM TR 88-C-003, Presented at Fifth International Power Transmissions and Gearing Conference, ASME, Chicago, Apr. 25-28, 1989, in Proceedings of the 1989 International Power Transmission and Gearing Conference, ASME, New York, Vol. 1, pp. 409-419, 1989.

Lin, H.H., Oswald, F.B., Rebbechi, B., Zakrajsek, J.J., and Townsend, D.P.: Comparison of Analysis and Experiment for Dynamics of Low Contact Ratio Spur Gears, NASA TM-103232, AVSCOM 90-C-017, in process.

Lin, H.H., Townsend D.P., and Oswald F.B.: Profile Modification to Minimize Spur Gear Dynamic Loading, NASA TM-89901, Presented at Fifth International Power Transmission and Gearing Conference, Chicago, ASME, Chicago, Apr. 25-28, 1989, in Proceedings of the 1989 International Power Transmission and Gearing Conference, ASME, New York, Vol. 1, pp. 455-465, 1989.

Liou, C-H., Lin, H.H., Oswald, F.B., and Townsend, D.P.: Effect of Contact Ratio on Spur Gear Dynamic Load, NASA TM-105606, AVSCOM TR 91-C-025, ASME publication DE-Vol. 43-1, pp. 29-31, Presented at ASME 6th Int. Power Transmission and Gearing Conference, Scottsdale, AZ, Sept. 13-16, 1992.

Litvin, F.L.: Theory of Gearing, NASA RP-1212, AVSCOM TR-88-C-035, Dec. 1989.

Litvin, F.L., Kuan, C., Kieffer, J., Bossler, R., and Handschuh, R.F.: Straddle Design of Spiral Bevel and Hypoid Pinions and Gears, NASA TM-103621, AVSCOM TR 90-C-010, Nov. 1990.

Litvin, F.L., Kuan, C., Wang, J.-C., Handschuh, R.F., Masseth, J., and Maruyama, N.: Minimization of Deviations of Gear Real Tooth Surfaces Determined by Coordinate Measurements, NASA TM-105718, AVSCOM TR 92-C-003, ASME publication DE-Vol. 43-1, pp. 193-200, Presented ASME at 6th Int. Power Transmission and Gearing Conference, Scottsdale, AZ, Sept. 13-16, 1992.

Litvin, F.L., Kuan, C., and Zhang, Y.: Determination of Real Machine-Tool Settings and Minimization of Real Surface Deviation by Computerized Inspection, NASA CR 4383, AVSCOM TR 91-C-021, Grant NAG 3-964, July 1991.

Litvin, F.L. and Lee, H-T.: Generation and Tooth Contact Analysis of Spiral Bevel Gears With Predesigned Parabolic Functions of Transmission Errors, NASA CR-4259, AVSCOM TR 89-C-014, Nov. 1989.

**Litvin, F.L. and Tsay, C.-B: Helical Gears with Circular Arc Teeth: Generation, Geometry, Precision and Adjustment to Errors, Computer Aided Simulation of Conditions of Meshing and Bearing Contact, NASA CR-4089, AVSCOM TR 87-C-18, Oct. 1987.**

**Litvin, F.L., Tsay, C.-B.P., Coy, J.J. and Handschuh, R.F.: Helical Gears with Pinion Circular Arc Teeth and Gear Screw Involute Teeth, USAAVSCOM TR 86-C-5, AGMA paper 86-FTM-3, presented at the American Gear Manufacturers Association Technical Meeting, Chicago, IL, Oct. 1986.**

**Litvin F.L., Tsung, W.-J., Coy, J.J., and Handschuh, R.F., and Tsay, C.-B.P.: New Generation Methods for Spur, Helical, and Spiral Bevel Gears, NASA TM-88862, USAAVSCOM TR 86-C-27, presented at the Rotary Wing Propulsion System Specialist Meeting, American Helicopter Society, Williamsburg, VA, Nov. 12-14, 1986.**

**Litvin, F.L., Tsung, W.-J., Coy, J.J., and Heine, C.: Generated Spiral Bevel Gears: Optimal Machine-Tool Settings and Tooth Contact Analysis, NASA TM-87075, USAAVSCOM TR 85-C-9, prepared for the 1985 Off-Highway and Power Plant Congress and Exposition sponsored by the Society of Automotive Engineers, Milwaukee, WI, Sept. 9-12, 1985.**

**Litvin, F.L., Tsung, W.-J., Coy, J.J., and Heine, C.: Generation of Conjugate Spiral Bevel Gears and Their Tooth Contact Analysis, USAAVSCOM TR 86-C-1, AGMA paper 86-FTM-2, presented at the AGMA Technical Meeting, Chicago, IL, Oct. 1986.**

**Litvin, F.L., Tsung, W.-J., Coy, J.J., and Heine, C.: Generation of Spiral Bevel Gears with Zero Kinematical Errors and Computer Aided Tooth Contact Analysis, NASA TM-87273, USAAVSCOM, TR 86-C-2, Mar. 1986.**

**Litvin, F.L., Tsung, W.-J., Coy, J.J., and Heine, C.: Method for Generation of Spiral Bevel Gears With Conjugate Gear Tooth Surfaces, Journal of Mechanisms, Transmission, and Automation in Design, Vol. 109, pp. 163-170, June 1987.**

**Litvin, F.L., Tsung, W.J., and Lee, H.T.: Generation of Spiral Bevel Gears with Conjugate Tooth Surfaces and Tooth Contact Analysis, NASA CR-4088, AVSCOM TR 87-C-22, Aug. 1987.**

**Litvin, F.L., Tsung, W.-T, Tsay, C.-B, Coy, J.J., and Handschuh, R.F.: Spiral Bevel and Circular Arc Helical Gears: Tooth Contact Analysis and the Effect of Misalignment on Circular Arc Helical Gears, NASA TM-87013, USAAVSCOM TR 85-C-6, presented at the 21st Joint Propulsion Conference cosponsored by the AIAA, SAE and ASME, Monterrey, CA, July 8-10, 1985.**

**Litvin, F.L., Wang, J-C., Bossler, Jr., R.B., Chen Y.-J.D., Heath, G., and Lewicki, D.G.: Application of Face-Gear Drives in Helicopter Transmissions, NASA TM-105655, AVSCOM TR 91-C-036, ASME publication DE-Vol. 43-1, pp. 267-274 Presented at ASME 6th Int. Power Transmission and Gearing Conference, Scottsdale, AZ, Sept. 13-16, 1992.**

**Litvin, F.L., Wang, J-C., Bossler, Jr., R.B., Chen Y.-J.D., Heath, G., and Lewicki, D.G.: Face-Gear Drives: Design, Analysis and Testing for Helicopter Transmission Applications, AGMA publication 92 FTM2, Presented at AGMA Fall Technical Meeting, Baltimore, MD, Oct. 26-28, 1992.**

**Litvin, F.L. and Zhang, J.: Spur Gears: Optimal Geometry, Methods for Generation and Tooth Contact Analysis (TCA) Program, NASA CR-4135, AVSCOM TR 88-C-002, Apr. 1988.**

Litvin, F.L. and Zhang, J.: Topology of Modified Helical Gears and Tooth Contact (TCA) Program, NASA CR-4224, AVSCOM TR 89-C-002, Apr., 1989.

Litvin, F.L., Zhang, J., Chaing, W.-S., Coy, J.J., and Handschuh, R.F.: Crowned Spur Gears: Optimal Geometry and Generation, Gear Technology, Vol. 5, No. 5, pp. 9-15, Sept./Oct. 1988.

Litvin, F.L., Zhang, J., and Handschuh, R.F.: Crowned Spur Gears: Methods for Generation and Tooth Contact Analysis—Part I: Generation of a Crowned Pinion Tooth Surface by a Plane, Journal of Mechanisms, Transmissions, and Automation in Design, Vol. 110, No. 3, pp. 337-342, Sept. 1988.

Litvin, F.L., Zhang, J., and Handschuh, R.F.: Crowned Spur Gears: Methods for Generation and Tooth Contact Analysis—Part II, Generation of a Crowned Pinion Tooth Surface by a Surface of Revolution, Journal of Mechanisms, Transmissions, and Automation in Design, Vol. 110, No. 3, pp. 343-347, Sept. 1988.

Litvin, F.L., Zhang, J., and Handschuh, R.F.: Crowned Spur Gears: Methods for Generation and Tooth Contact Analysis—Part 1: Generation of the Pinion Tooth Surface by a Surface of Revolution, Presented at Fifth International Power Transmission and Gearing Conference, ASME, Chicago, Apr. 25-28, 1989, in Proceedings of the 1989 International Power Transmission and Gearing Conference, ASME, New York, Vol. 2, pp. 613-619, 1989.

Litvin, F.L., Zhang, J., and Handschuh, R.F.: Crowned Spur Gears: Methods for Generation and Tooth Contact Analysis—Part 2: Generation of the Pinion Tooth Surface by a Surface of Revolution, Presented at Fifth International Power Transmission and Gearing Conference, ASME, Chicago, Apr. 25-28, 1989, in Proceedings of the 1989 International Power Transmission and Gearing Conference, ASME, New York, Vol. 2, pp. 621-626, 1989.

Litvin, F.L., Zhang, J., and Handschuh, R.F.: Generation of a Crowned Pinion Tooth Surface by a Plane, NASA TM-100259, AVSCOM TR 87-C-33, Sept. 1988.

Litvin, F.L., Zhang, J., and Handschuh, R.F.: Generation of a Crowned Pinion Tooth Surface by a Surface of Revolution, NASA TM-100260, AVSCOM TR 87-C-34, Sept. 1988.

Litvin, F.L., Zhang, J., Handschuh, R.F., and Coy, J.J.: Topology of Modified Helical Gears, NASA TM 102134, AVSCOM TR 89-C-004, Surface Topography, Vol. 2, Issue 1, pp. 41-58, Mar. 1989, also presented at Fifth International Power Transmission and Gear Conference, ASME, Chicago, Apr. 25-28, 1989, in Proceedings of the 1989 International Power Transmission and Gearing Conference, ASME, New York, Vol.2, pp. 547-554, 1989.

Litvin, F.L. and Zhang, Y.: Local Synthesis and Tooth Contact Analysis of Face-Milled Spiral Bevel Gears, NASA CR 4342, AVSCOM TR 90-C-028, Jan. 1991.

Litvin, F.L., Zhang, Y., and Chen, J.: User's Manual for Tooth Contact Analysis of Face-Milled Spiral Bevel Gears with Given Machine—Tool Settings, NASA CR-189093, AVSCOM TR 91-C-051, Dec. 1991.

Litvin, F.L., Zhang, Y., and Handschuh, R.F.: Local Synthesis and Tooth Contact Analysis of Face-Milled Spiral Bevel Gears, NASA TM-105182, AVSCOM TR 91-C-039, the International Conference on Motion and Power Transmissions, JSME/ASME/I.Mech.E/VDI/IET/CSME and other societies, Hiroshima, Japan, Nov. 24-26, 1991.

Litvin, F.L., Zhang, Y., Kieffer, J. and Handschuh, R.F.: Identification and Minimization of Deviations of Real Gear Tooth Surfaces, *Journal of Mechanical Design*, Vol. 113, No. 1, pp. 55-62, Mar. 1991.

Litvin, F.L., Zhang, Y., Kieffer, J., Handschuh, R.F., and Coy, J.J.: Computerized Inspection of Gear Tooth Surfaces, NASA TM-102395, AVSCOM TR 89-C-011, Presented at SIAM Conference on Geometric Design, Tempe, AZ, Nov. 6-10, 1989.

Litvin, F.L., Zhang, Y., Kuan, C., and Handschuh, R.F.: Computerized Inspection of Real Surfaces and Minimization of Their Deviations, NASA TM 103798, AVSCOM TR 91-C-008, presented at 5th International Conference on Metrology and Properties of Engineering Surfaces, Leicester Polytechnic, England, Apr. 10-12, 1991.

Litvin, F.L., Zhang, J., Lee H.-T., and Handschuh, R.F.: Transmission Errors and Bearing Contact of Spur, Helical and Spiral Bevel Gears, SAE Paper 881294, presented at SAE International Off-Highway & Powerplant Congress & Exposition, Milwaukee, WI, Sept. 12-15, 1988.

Litvin, F.L., Zhang, Y., Lundy, M., and Heine, C.: Determination of Settings of a Tilted Head-Cutter for Generation of Hypoid and Spiral Bevel Gears, NASA CR-182138, AVSCOM TR-88-C-016, June 1988.

Mark, W.D.: Analysis of the Vibratory Excitation Arising from Spiral Bevel Gears, NASA CR 4081, July 1987.

Mark, W.D.: The Generalized Transmission Error of Spiral Bevel Gears, *Journal of Mechanisms, Transmissions and Automation in Design*, Vol. 109, pp. 275-282, June 1987.

Mark, W.D.: Use of the Generalized Transmission Error in the Equations of Motion of Gear Systems, *Journal of Mechanisms, Transmissions and Automation in Design*, Vol. 109, pp. 283-291, June 1987.

Mavriplis, D., and Huston, R.L.: Computer Simulation of Gear Tooth Manufacturing Processes, NASA CR-185200, AVSCOM TM 90-C-003, Feb. 1990.

Mitchell, A.M., Oswald, F.B., and Coe, H.H.: Testing the UH-60A Helicopter Transmission in the NASA Lewis 3000 HP Facility, NASA TP-2626, Aug. 1986.

Mitchell, A.M., Oswald, F.B., and Schuller, F.T.: Testing of YUH-61A Helicopter Transmission in NASA Lewis 2240-kW (3000 HP) Facility, NASA TP-2538, Mar. 1986.

Mitchell, Jr., G.D.: Manufacturing Techniques—Split Torque Path Helicopter Transmission, AHS Paper No. A-91-47130-5000, presented at American Helicopter Society 47th Annual Forum, Phoenix, May 6-8, 1991.

Mizutani, H., Isikawa, Y., and Townsend, D.P.: Effects of Lubrication on the Performance of High Speed Spur Gears, NASA TM-101969, Presented at Fifth International Power Transmission and Gearing Conference, ASME, Chicago, Apr. 25-28, 1989, in Proceedings of the 1989 International Power Transmission and Gearing Conference, ASME, New York, Vol. 1, pp. 327-334, 1989.

Oswald, F.B.: Gear Tooth Stress Measurements on the UH-60A Helicopter Transmission, NASA TP-2698, Mar. 1987.

- Oswald, F.B., Rebbechi, B., Zakrajsek, J.J., Townsend, D.P., and Lin, H.H.: Comparison of Analysis and Experiment for Dynamics of Low-Contact-Ratio Spur Gears, NASA TM-103232, AVSCOM 90-C-017, presented at ASME 13th Biennial Conference on Mechanical Vibration and Noise, Miami, Sept. 22-25, 1991.
- Oswald, F.B., Seybert, A.F., Wu, T.W., and Atherton, W.: Comparison of Analysis and Experiment for Gearbox Noise, NASA TM-105330, AVSCOM TR 91-C-030, ASME publication DE-Vol. 43-2, pp. 675-679, Presented at ASME 6th Int. Power Transmission and Gearing Conference, Scottsdale, AZ, Sept. 13-16, 1992.
- Oswald, F.B., Zakrajsek, J.J., Townsend, D.P., Atherton, W., and Lin, H.H.: Effect of Operating Conditions on Gearbox Noise, NASA TM-105331, AVSCOM TR 91-C-031, ASME publication DE-Vol. 43-2, pp. 669-664, Presented at ASME 6th Int. Power Transmission and Gearing Conference, Scottsdale, AZ, Sept. 13-16, 1992.
- Passerello, C.E. and Shuey, L.W.: An Investigation of the Dynamic Response of Spur Gear Teeth With Moving Loads, NASA CR-179643, AVSCOM TR 87-C-23, Aug. 1987.
- Rashidi, M. and Krantz, T.L.: Dynamics of a Split Torque Helicopter Transmission, NASA TM-105681, AVSCOM TR 91-C-043, ASME publication DE-Vol. 43-1, pp. 347-358, Presented at ASME 6th Int. Power Transmission and Gearing Conference, Scottsdale, AZ, Sept. 13-16, 1992.
- Rebbechi, B., Forrester, B.D., Oswald, F.B., and Townsend, D.P.: A Comparison Between Theoretical Prediction and Experimental Measurement of the Dynamic Behaviour of Spur Gears, NASA TM-105362, AVSCOM TR 91-C-009, ASME publication DE-Vol. 43-2, pp. 431-438, Presented at ASME 6th Int. Power Transmission and Gearing Conference, Scottsdale, AZ, Sept. 13-16, 1992.
- Rebbechi, B., Oswald, F.B., and Townsend, D.P.: Dynamic Measurements of Gear Tooth Friction and Load, NASA TM 103281, AVSCOM TR 90-C-023, presented at the AGMA Fall Technical Meeting, Detroit, Oct. 21-23, 1991.
- Rosenlieb, J.W.: Planetary-Gear-Support Bearing Test Rig Design, NASA CR-174927, Mar. 1985.
- Savage, M.: Life and Dynamic Capacity Modeling for Aircraft Transmissions, NASA CR-4341, AVSCOM TR 90-C-027, Jan. 1991.
- Savage, M., Altidis, P.C., Lewicki, D.G., Coy, J.J., and Litvin, F.L.: Tooth Contact Shift in Loaded Spiral Bevel Gears, NASA TM-101438, AVSCOM TR 87-C-36, presented at Fifth International Power Transmission and Gearing Conference, ASME, Chicago, Apr. 25-28, 1989, in Proceedings of the 1989 International Power Transmission and Gearing Conference, ASME, New York, Vol. 1, pp. 203-212, 1989.
- Savage, M. and Brikmanis, C.K.: System Life and Reliability Modeling for Helicopter Transmissions, NASA CR-3967, Apr. 1986.
- Savage, M., Brikmanis, C.K., Lewicki, D.G., and Coy, J.J.: Life and Reliability Modeling of Bevel Gear Reductions, NASA TM-87006, USAAVSCOM TR 85-C-3, prepared for the National Design Engineering Conference sponsored by the ASME, Chicago, IL, Mar. 11-13, 1985.

**Savage, M., Caldwell, R.J., Wisor, G.D., and Lewicki, D.G.: Gear Mesh Compliance Modeling, NASA TM-88843, USAAVSCOM TR-86-C-28, presented at the Rotary Wing Propulsion System Specialist Meeting, American Helicopter Society, Williamsburg, VA, Nov. 12-14, 1986.**

**Savage, M., Lattime, S.B., Kimmel, J.A., and Coe H.H.: Optimal Design of Compact Spur Gear Reductions, NASA TM-105676, AVSCOM TR 91-C-041, ASME publication DE-Vol. 43-1, pp. 383-390, Presented at ASME 6th Int. Power Transmission and Gearing Conference, Scottsdale, AZ, Sept. 13-16, 1992.**

**Savage, M. and Lewicki, D.G.: Transmission Overhaul and Replacement Predictions Using Weibull and Renewal Theory, NASA TM-102022, AIAA -89-2919, AVSCOM TR 89-C-007, Presented at 25th Joint Propulsion Conference co-sponsored by the AIAA, ASME, SAE, and ASEE, Monterrey, CA, July 10-12, 1989.**

**Savage, M. and Lewicki, D.G.: Transmission Overhaul Estimates for Partial and Full Replacement at Repair, NASA TM-104395, AVSCOM TR 91-C-010, the International Conference on Motion and Power Transmissions, JSME/ASME/I.Mech.E/VDI/IET/CSME and other societies, Hiroshima, Japan, Nov. 24-26, 1991.**

**Savage, M., Mackulin, M.J., Coe, H.H., and Coy, J.J.: Maximum Life Spur Gear Design, NASA TM-104361, AVSCOM TR 90-C-024, AIAA paper 91-2021, presented at AIAA/SAE/ASME/ASEE 27th Joint Propulsion Conference, Sacramento, June 24-27, 1991.**

**Savage, M., Prasanna, M.G., and Coe, H.H.: Maximum Life Spiral Bevel Reduction Design, NASA TM-105790, AVSCOM TR 92-C-004, AIAA-92-3493, Presented at AIAA/SAE/ASME/ASEE 28th Joint Propulsion Conference. Nashville, TN, July 6-8, 1992.**

**Savage, M., Radil, D.C., Lewicki, D.G., and Coy, J.J.: Computerized Life and Reliability Modelling for Turboprop Transmissions, NASA TM-100918, AVSCOM TR 87-C-37, AIAA paper 88-2979, presented at 24th Joint Propulsion Conference, Boston, July 11-13, 1988.**

**Scibbe, H.W., Townsend, D.P. and Aron, P.R.: Effect of Lubricant Extreme-Pressure Additives on Surface Fatigue Life of AISI 9310 Spur Gears, NASA TP-2408, Dec. 1984.**

**Scott, H.W.: Computer Numerical Control Grinding of Spiral Bevel Gears, NASA CR-187175, AVSCOM TR 90-F-6, Aug. 1991.**

**Seybert, A.F. and Oswald, F.B.: Experimental Validation of Boundary Element Methods for Noise Prediction, NASA TM-105729, AVSCOM TR 92-C-013, Presented at Inter-Noise, International Institute of Noise Control Engineering, Toronto, Canada, July 20-22, 1992.**

**Seybert, A.F., Wu, T.W., Wu, X.F. and Oswald F.B.: Acoustical Analysis of Gear Housing Vibration, NASA TM-103691, AVSCOM TM 90-C-002, presented at AHS Technical Specialists Meeting, Philadelphia, Oct. 15-16, 1991.**

**Seybert, A.F., Wu, X.F., and Oswald, F.B.: Validation of Finite Element and Boundary Element Methods for Predicting Structural Vibration and Radiated Noise, NASA TM-105359, AVSCOM TR 92-C-050, Presented at ASME Winter Annual Meeting, Anaheim, CA, Nov. 8-13, 1992.**

ugh, R., Houser, D.R., and Kahraman, A.: Non-Linear Dynamic Analysis of Geared Systems, NASA CR-4338, AVSCOM TR 90-C-020, Nov. 1990.

ugh, R., and Lim, T.C.: Vibration Transmission Through Rolling Element Bearings in Geared Rotor Systems, NASA CR-4334, AVSCOM TR 90-C-019, Nov. 1990.

omprakit, P. and Huston, R.L.: A New Procedure for Calculating Contact Stresses in Gear Teeth, NASA CR-187094, AVSCOM TR 91-C-012, Apr. 1991.

omprakit, P., Huston, R.L., and Oswald, F.B.: Contact Stresses in Gear Teeth—A New Method of Analysis, NASA TM-104397, AVSCOM TR 91-C-001, AIAA paper 91-2022, presented at IAA/SAE/ASME/ASEE 27th Joint Propulsion Conference, Sacramento, June 24-27, 1991.

un, H., Mavriplis, D., Huston, R.L. and Oswald, F.B.: Comparison of Boundary Element and Finite Element Methods in Spur Gear Root Stress Analysis, Presented at Fifth International Power Transmission and Gearing Conference, ASME, Chicago, Apr. 25-28, 1989, in Proceedings of the 1989 International Power Transmission and Gearing Conference, ASME, New York, Vol. 1, pp. 163-166, 1989.

ownsend, D.P.: Common Problems and Pitfalls in Gear Design, NASA TM-88858, presented at the Original Equipment Manufacturing Design Conference, New York, Dec. 9-11, 1986.

ownsend, D.P.: Improvement in Surface Fatigue Life of Hardened Gears by High-Intensity Shot Peening, NASA TM-105678, AVSCOM TR 91-C-042, ASME publication DE-Vol. 43-2, pp. 643-649, Presented at ASME 6th Int. Power Transmission and Gearing Conference, Scottsdale, AZ, Sept. 13-16, 1992.

ownsend, D.P.: La lubrificazione degli ingranaggi. Organi di Trasmissione, (in Italian) pp. 113-116, Oct. 1987.

ownsend, D.P.: Lubrication and Cooling for High Speed Gears, TM-87096, presented at OEM Design Conference, Philadelphia, Sept. 9-11, 1985.

ownsend, D.P.: Surface Fatigue Life and Failure Characteristics of EX-53, CBS 1000M, and AISI 9310 Gear Materials, NASA TP-2513, Oct. 1985.

ownsend, D.P.: Surface Fatigue and Failure Characteristics, of Hot Forged Powder Metal AISI 4620, AISI 4640, and Machined AISI 4340 Steel Spur Gears, NASA TM 87330, presented at the ASLE Annual Meeting, Toronto, Canada, May 12-15, 1986.

ownsend, D.P.: Surface Pitting Fatigue Life of Noninvolute, Low-Contact-Ratio Gears, NASA TM-103116, AVSCOM TR 90-C-008, presented at the 26th Joint Propulsion Conference, AIAA/SAE/ASME/ASEE, Orlando, FL, July 16-18, 1990.

ownsend, D.P. and Bamberger, E.N.: Surface Fatigue Life of Carburized and Hardened M50NiL and AISI 9310 Spur Gears and Rolling-Contact Test Bars, NASA TM-101979, AVSCOM TR 89-C-011, Presented at 25th Joint Propulsion Conference co-sponsored by the AIAA, ASME, SAE, and ASEE, Monterey, CA, July 10-12, 1989.

Townsend, D.P. and Bamberger, E.N.: Surface Fatigue Life of M50NiL and AISI 9310 Spur Gears and RC Bars, NASA TM-104496, AVSCOM TR 91-C-034, presented at the International Conference on Motion and Power Transmissions, JSME/ASME/I.Mech.E/VDI/IET/CSME and other societies, Hiroshima, Japan, Nov. 24-26, 1991.

Townsend, D.P. and Patel, P.R.: Surface Fatigue Life of CBN and Vitreous Ground Carburized and Hardened AISI 9310 Spur Gears, NASA TM-100960, AVSCOM TR 88-C-019, SAE Paper 881294, presented at SAE International Off-Highway & Powerplant Congress & Exposition, Milwaukee, WI, Sept. 12-15, 1988.

Townsend, D.P. and Shimski, J.: Effect of Two Synthetic Lubricants on Life of AISI 9310 Spur Gears. NASA TM-104352, AVSCOM TR 91-C-011, June 1991.

Townsend, D.P. and Shimski, J.: Evaluation of Advanced Lubricants for Aircraft Applications Using Gear Surface Fatigue Tests, NASA TM-104336, AVSCOM TR 91-C-007; AIAA paper 91-1907, presented at AIAA/SAE/ASME/ASEE 27th Joint Propulsion Conference, Sacramento, June 24-27, 1991.

Townsend, D.P. and Zaretsky, E.V.: Effect of Five Lubricants on Life of AISI 9310 Spur Gears, NASA TP-2419, Jan. 1985.

Townsend, D.P. and Zaretsky, E.V.: Effect of Shot Peening on Surface Fatigue Life of Carburized and Hardened AISI 9310 Spur Gears, Gear Technology, Vol. 3, No. 1, pp. 29-36, Jan. 1986.

Townsend, D.P., Zaretsky, E.V., and Scibbe, H.W.: Lubricant and Additive Effects on Spur Gear Fatigue Life, NASA TM-87044, prepared for the 1985 Lubrication Conference cosponsored by the ASME and the ASLE, Atlanta, GA. Oct. 8-10, 1985.

Townsend, D.P., Zaretsky, E.V. and Scibbe, H.W.: Lubricant and Additive Effects on Spur Gear Fatigue Life, Transactions of The ASME, Vol. 108, July 1986.

Townsend, D.P., Zaretsky, E.V., and Scibbe, H.W.: Lubricant and Additive Effects on Spur Gear Fatigue Life, presented at Technische Akademie Esslingen 6th Int'l Colloquium, Stuttgart, Jan. 12-14, 1988, in Industrial Lubricants-Properties, Application, Disposal, Vol. 1, pp. 8.5-1 to 8.5-14, Tech. Acad. Esslingen, W.J. Bartz (ed), 1988.

Vanderplaats, G.N., Chen, X., and Zhang, N.: Gear Optimization, NASA CR-4201, Dec. 1988.

Weden, G.J. and Coy, J.J.: Summary of Drive-Train Component Technology in Helicopters, NASA TM-83726, USAAVSCOM 84-C-10, presented at the NATO-AGARD PEP 64th Symposium on Gears and Power Transmissions for Helicopters and Turboprops Lisbon, Portugal, Oct. 8-12, 1984.

White, G.: 3600 HP Split Torque Helicopter Transmission. CR-174932, NAS3-23931, Dec. 1985.

Xiaoling, W. and Townsend, D.P.: The Distribution of Oil film Thickness Along the Contact Line of Gears, NASA TM-102035, Prepared for the 25th Joint Propulsion Conference cosponsored by the AIAA, ASME, SAE, and ASEE, Monterrey, CA, July 10-12, 1989.

Zakrajsek, J.J.: An Investigation of Gear Mesh Failure Prediction Techniques. NASA TM-102340, AVSCOM TM 89-C-005. Nov. 1989.

Zakrajsek, J.J.: Comparison Study of Gear Dynamic Computer Programs at NASA Lewis Research Center, NASA TP-2901, AVSCOM TR 88-C-010, Mar., 1989.

Zakrajsek, J.J., Oswald, F.B., Townsend D.P., and Coy, J.J.: Gear Noise, Vibration, and Diagnostic Studies at NASA Lewis Research Center, NASA TM-102435, AVSCOM TM 89-C-020, presented at the First International Conference on Gearbox Noise and Vibration. IMechE. Apr. 9-11. 1990.

Zakrajsek, J.J., Townsend, D.P., Oswald, F.B., and Decker H.J.: Analysis and Modification of a Single-Mesh Gear Fatigue Rig for Use in Diagnostic Studies, NASA TM-105416, AVSCOM TR 91-C-049, May 1992.

Zaretsky, E.V., Schuller, F.T., and Coe, H.H.: Lubrication and Performance of High-Speed Rolling-Element Bearings, NASA TM-86958, ASLE Preprint 85-AM-3F-2, presented at the 40th ASLE Annual Meeting in Las Vegas, NV, May 6-9, 1985.

**REPORT DOCUMENTATION PAGE**Form Approved  
OMB No. 0704-0188

Public reporting burden for this collection of information is estimated to average 1 hour per response, including the time for reviewing instructions, searching existing data sources, gathering and maintaining the data needed, and completing and reviewing the collection of information. Send comments regarding this burden estimate or any other aspect of this collection of information, including suggestions for reducing this burden, to Washington Headquarters Services, Directorate for Information Operations and Reports, 1215 Jefferson Davis Highway, Suite 1204, Arlington, VA 22202-4302, and to the Office of Management and Budget, Paperwork Reduction Project (0704-0188), Washington, DC 20503.

<b>1. AGENCY USE ONLY (Leave blank)</b>		<b>2. REPORT DATE</b> September 1993	<b>3. REPORT TYPE AND DATES COVERED</b> Technical Memorandum	
<b>4. TITLE AND SUBTITLE</b> Mechanical Systems Technology Branch Research Summary, 1985-1992			<b>5. FUNDING NUMBERS</b>  WU-505-62-10 1L162211A47A	
<b>6. AUTHOR(S)</b> Timothy L. Krantz				
<b>7. PERFORMING ORGANIZATION NAME(S) AND ADDRESS(ES)</b> NASA Lewis Research Center Cleveland, Ohio 44135-3191 and Vehicle Propulsion Directorate U.S. Army Research Laboratory Cleveland, Ohio 44135-3191			<b>8. PERFORMING ORGANIZATION REPORT NUMBER</b>  E-6886	
<b>9. SPONSORING/MONITORING AGENCY NAME(S) AND ADDRESS(ES)</b> National Aeronautics and Space Administration Washington, D.C. 20546-0001 and U.S. Army Research Laboratory Adelphi, Maryland 20783-1145			<b>10. SPONSORING/MONITORING AGENCY REPORT NUMBER</b>  NASA TM-106329 ARL-TR-237	
<b>11. SUPPLEMENTARY NOTES</b> Responsible person, Timothy L. Krantz, (216) 433-3580.				
<b>12a. DISTRIBUTION/AVAILABILITY STATEMENT</b>  Unclassified - Unlimited Subject Category 37			<b>12b. DISTRIBUTION CODE</b>  -	
<b>13. ABSTRACT (Maximum 200 words)</b>  This publication contains a collection of significant accomplishments from the research of the Mechanical Systems Technology Branch at the NASA Lewis Research Center completed during the years 1985-1992. The publication highlights and accomplishments made in bearing and gearing technology through in-house research, university grants, and industry contracted projects. The publication also includes a complete listing of branch publications for these years.				
<b>14. SUBJECT TERMS</b> Transmissions; Gears; Bearings; Helicopters			<b>15. NUMBER OF PAGES</b> 85	
			<b>16. PRICE CODE</b> A05	
<b>17. SECURITY CLASSIFICATION OF REPORT</b> Unclassified	<b>18. SECURITY CLASSIFICATION OF THIS PAGE</b> Unclassified	<b>19. SECURITY CLASSIFICATION OF ABSTRACT</b> Unclassified	<b>20. LIMITATION OF ABSTRACT</b>	