



AD-A276 502



January 1994

The DoD Enterprise Model
Briefing Slides

Office of the Secretary of Defense
ASD(C³I)

DTIC
FLECTE
FEB 22 1994
S E D

To replace present version ADA261724, keep same
AD number

Same distribution

Accession For	
NTIS CRA&I	<input checked="" type="checkbox"/>
DTIC TAB	<input type="checkbox"/>
Unannounced	<input type="checkbox"/>
Justification	
By _____	
Distribution/	
Availability Codes	
Dist	Avail and/or Special
A-1	

DTIC QUALITY INSPECTED 2

Add to CIM Collection

90

Unclassified

Unclassified

Unclassified

**Best
Available
Copy**



The DoD Enterprise Model

The DoD Enterprise Model Symposium

January 11, 1994

***The Office of the Deputy Assistant Secretary of Defense
(IM)***

***The Office of the Assistant Secretary of Defense (C³I)
and***

***The Institute of Public Policy
George Mason University***

94-05438

2/1/94



9 4 2 18 0 5 7



The DoD Enterprise Model

The Constitution of the United States

Preamble

We the People of the United States, in Order to form a more perfect Union, establish Justice, insure domestic Tranquility, provide for the common defense, promote the general Welfare, and secure the Blessings of Liberty to ourselves and our Posterity, do ordain and establish this Constitution for the United States of America.



The DoD Enterprise Model

SCHEDULE

0800 - 0805	Administrative Remarks
0805 - 0815	Welcome to George Mason University
0815 - 0900	Enterprise Model Overview
0900 - 0915	Break
0915 - 1000	Enterprise Activity Model
1000 - 1045	Enterprise Data Model
1045 - 1100	Break
1100 - 1200	Blueprint for Integration

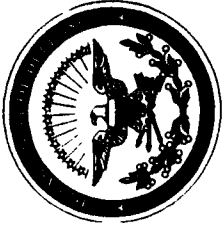

**WELCOME TO
GEORGE MASON
UNIVERSITY**



ENTERPRISE MODEL OVERVIEW



The DoD Enterprise Model

HANDOUT PACKAGE CONTENTS

- ***The DoD Enterprise Model***
 - ◆ ***Volume I: Strategic Activity and Data Models***
 - ◆ ***Volume II: Using the Model - A Strategic View of Change in DoD (A White Paper)***
 - ***GMU Paper: Functional Process Improvement Implementation - Public Sector Engineering***
 - ***Business Week: The Horizontal Corporation***
 - ***Hard Copy of this Briefing***
-



The DoD Enterprise Model

CURRENT DoD SITUATION

- ***Accelerated Force Downsizing -- All Components***
 - ***Evolving Missions***
 - ◆ ***Shift to Lower End Warfighting Scenarios (e.g., Regional, LIC)***
 - ◆ ***Additional Roles in Peacekeeping, Humanitarian Assistance...***
 - ***New Administration's "Vision" for Government***
 - ◆ ***Responsive***
 - ◆ ***Effective***
 - ◆ ***Efficient***
 - ◆ ***Innovative and Enterprising***
-



The DoD Enterprise Model

BEST BUSINESS PRACTICES

“ As I try to describe myself, I am an operator, hopefully with a strategic view.... In these last 10 years I’ve learned a lot about how business works, and I would hope to spend a lot of my time on bringing best business practices to the Department of Defense.... My sense in traveling the country is that the public is less concerned about what we’re doing overseas or our commitments than whether we are getting a dollar value for a dollar spent in defense. And I would hope at the end of our years of working together we will have persuaded them, Mr. President, that they are.”

ADM Bobby Ray Inman



The DoD Enterprise Model

OPPORTUNITY FOR INNOVATION

“ ... ‘There always comes a moment in time when a door opens and lets the future in.’ For more than four decades the Defense Department has built its strategy and programs on dealing with the cold war. The ending of the cold war has opened a door, and the future is waiting to come in. By our actions, and by the new strategies we develop, we can shape the future, instead of being shaped by it.”

**Dr. William J. Perry
Deputy Secretary of Defense**



The DoD Enterprise Model

DEFENSE ALTERNATIVES

- ☐ Cut Forces
- ☐ Defer Modernization
- ☐ Reduce Readiness and Sustainability

- ☐ Rapidly Become Far More Efficient and Cost-Effective

EFFECTIVENESS



Greater Efficiencies & Economies



Superior, Ready Defense Capabilities



Current Capabilities and Forces

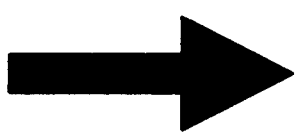

COST

Efficiencies and economies enable DoD to invest its limited resources in mission-effective capabilities



The DoD Enterprise Model

NEEDED - A DoD PARADIGM SHIFT TO CHANGE DIRECTION

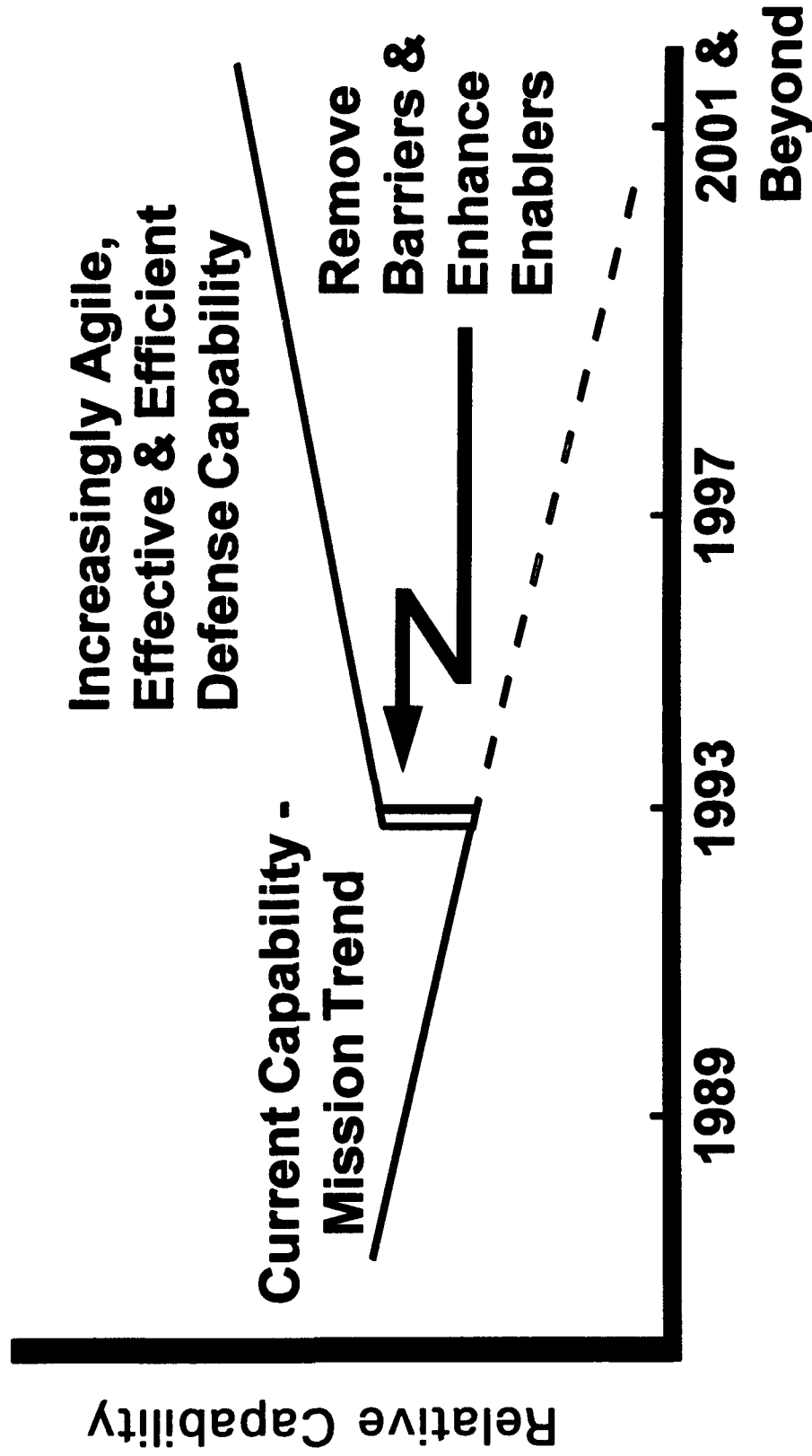



The DoD Enterprise Model

THE NEEDED SHIFT: Remove Barriers & Enhance Enablers

- Leadership is fragmented, parochial, tactical
- Policy and procedural innovation stifled under multiple layers of rules and regulations
- Absence of a "corporate" plan & feedback
- Customer expectations not part of today's quality equation
- Personnel rewarded for parochial actions & punished for risk taking
- No integrated, uniform performance & cost measurement system
- Key business methods not routinely analyzed for innovation and standardization
- Organizations structured in layered, inflexible hierarchies
- People not "empowered" to make decisions and take responsibility

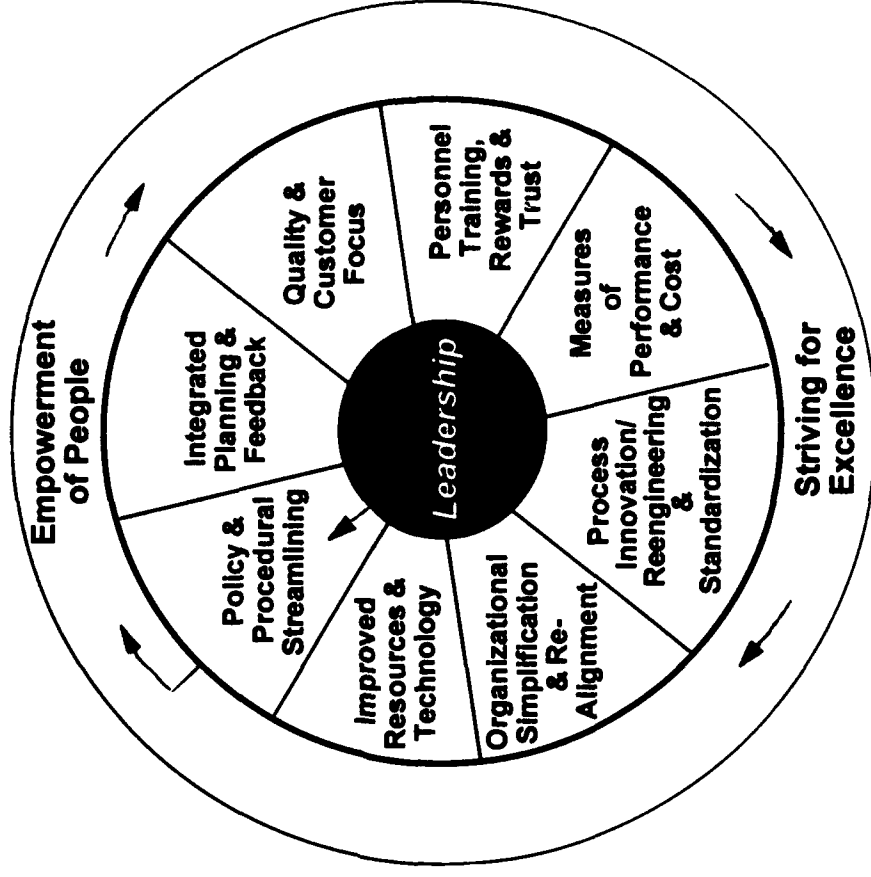

Key Barriers to Change

Key Enablers of Change



The DoD Enterprise Model

CRITICAL SUCCESS FACTORS (Industry Lessons Learned)

- ***Must have a vision, sponsorship, and concrete guidance from top leadership***
 - ◆ ***Eliminate, standardize, consolidate, leave alone, continuously improve, start from scratch***
 - ◆ ***Focus on removing constraints that limit speed, flexibility, and quality***
 - ***Must do a strategic analysis***
 - ◆ ***Fundamentally linked to business substance and realities***
 - ***Must have compelling business case***
 - ◆ ***Grounded in customer expectations and other first principles***
 - ***Must get leadership "buy-in" and enthusiastic support***
 - ◆ ***Mobilize resources and remove barriers***
 - ***Must maintain focus and commitment until goals are achieved***
 - ◆ ***Tactically flexible but unwavering in strategic direction***
-



The DoD Enterprise Model

IMPLEMENTATION CHECKLIST (Industry Lessons Learned)

- ***Build a culture that fosters innovation and initiative***
 - ***"Break the mold" to redesign the enterprise***
 - ***Ground change in understanding of the business and the needs of customers and consumers***
 - ◆ **Link strategies to detailed analysis and implementation**
 - ***Build a learning organization***
 - ***Let line managers and workers lead re-engineering***
 - ◆ **They are the functional experts (IT people can facilitate)**
 - ***Empower people - they make it happen***
-



The DoD Enterprise Model

THE CIM MODEL FOR CHANGE

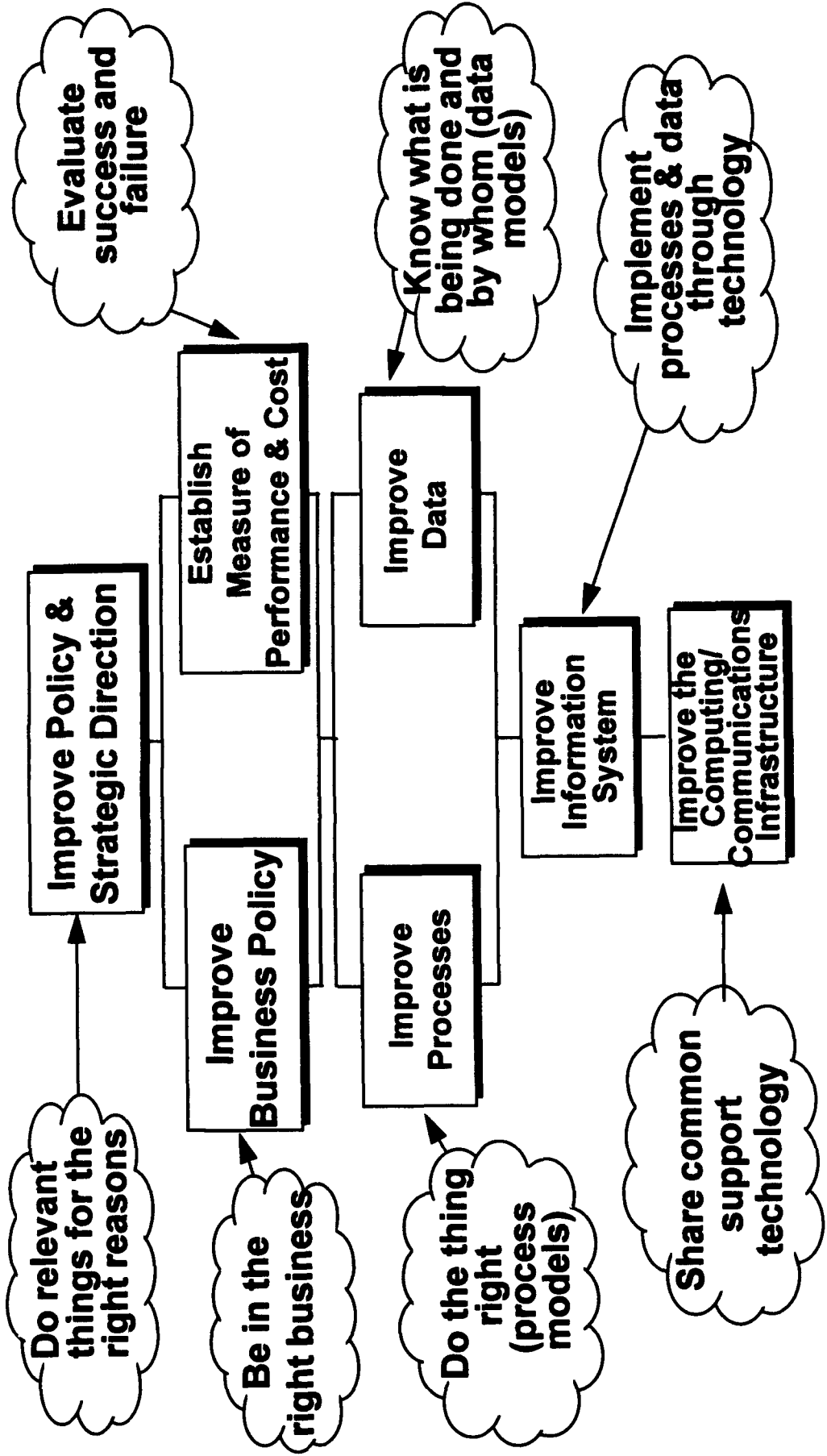



The DoD Enterprise Model

CIM GOALS AND OBJECTIVES

- ***Optimize Force Capability within Resources***
 - ***Embed Long-Term Change Throughout the Department***
 - ***Improve Functional Areas and Activities Across the Department***
-



The DoD Enterprise Model

CIM APPROACH

- *Top Down Functional Process Improvement Policy*
 - ◆ *The “Business Way”*
- *The DoD Enterprise Model*
 - ◆ *The Top Level Functional and Data Architecture*
- *Functional Process Improvement Initiatives*
 - ◆ *Imbedding Change Across the Department*
- *Shared Data Initiatives*
 - ◆ *Data as a Corporate Resource Linking Functions and Information Systems*
- *Defense Information Systems and Infrastructure*
 - ◆ *Common Migration Systems to Leverage the Information Resources*
 - ◆ *The Information “Utility” Supporting all DoD ISS*

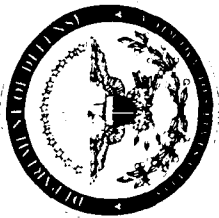

The DoD Enterprise Model

ESTABLISH FUNCTIONAL DIRECTION The DoD Enterprise Activity Model

Provide for the Common Defense

Establish Direction

- Establish Policy
- Determine Requirements
- Develop Plans
- Allocate Resources

Acquire Assets

- Manage Acquisition (Research, & Design)
- Produce Asset

Provide Capabilities

- Manage Assets
- Support Assets
- Provide Admin Services
- Develop Capabilities

Employ Service

- Constitute Forces
- Provide Operational Intelligence
- Conduct Operations
- Sustain Operations

With minor adjustments, this activity model applies to all levels of the enterprise

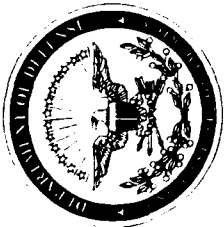

The DoD Enterprise Model

ESTABLISH FUNCTIONAL DIRECTION

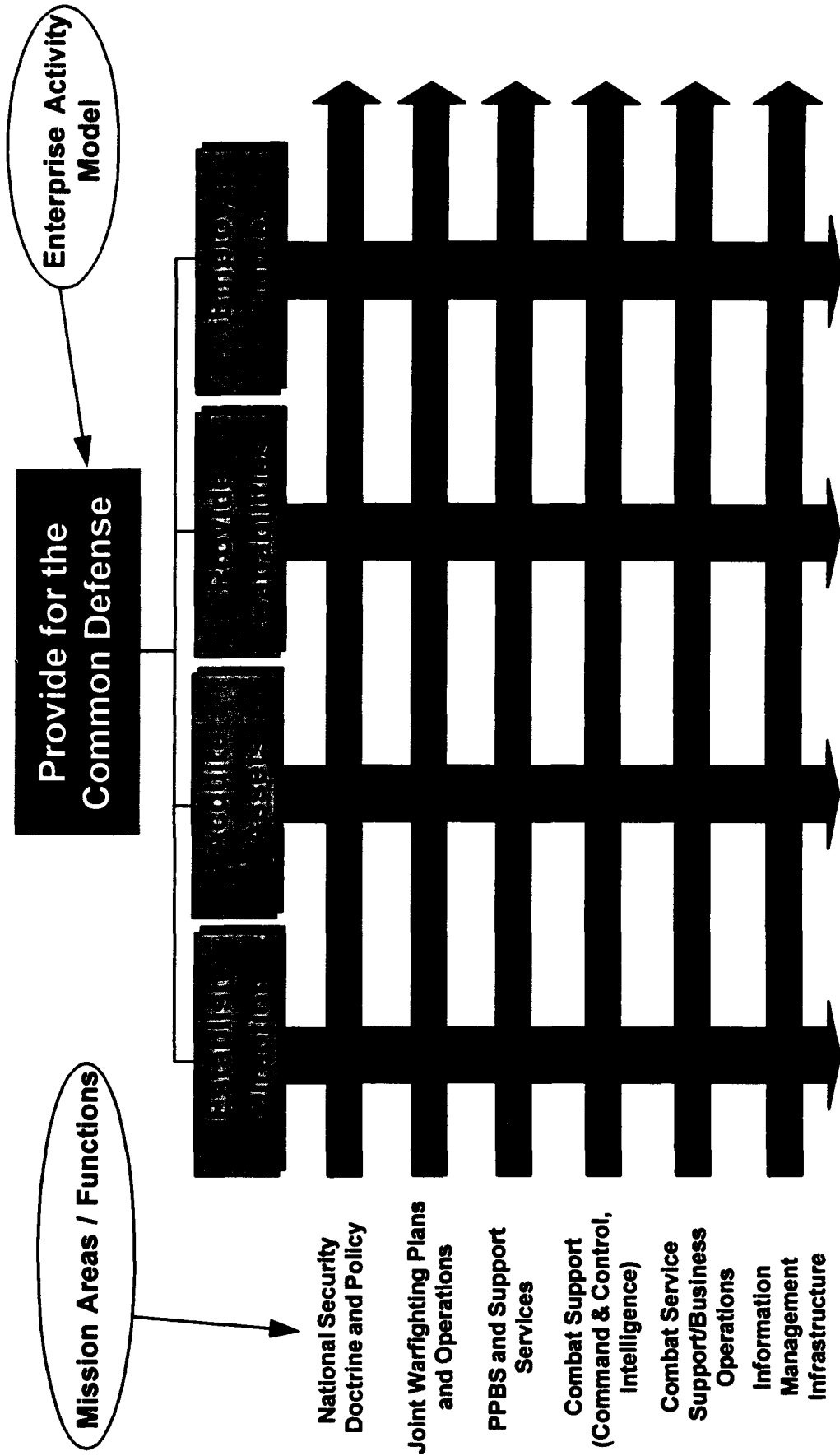



The DoD Enterprise Model

A BRIEF WORD ABOUT DATA

- *Process improvement efforts will produce data models*
 - ◆ Describe the “rules” of the process
 - ◆ The link among all our processes
- *Of use and interest to all managers, not just worker-level*
 - ◆ Aggregated data needed to establish direction



The DoD Enterprise Model

DATA AT THE STRATEGIC LEVEL A Few Examples

Data entities underlie our concepts...

SITUATIONS
<ul style="list-style-type: none">•Political•Military•Economic

ORGANIZATIONS
<ul style="list-style-type: none">•DoD•Other U.S. gov't•U.S. non-gov't•Foreign gov't•Foreign non-gov't

GUIDANCE
<ul style="list-style-type: none">•Strategies•Statutes•Policies•Directives•Doctrine•Missions

... and our assets

PEOPLE
<ul style="list-style-type: none">•Military•Civilian

MATERIEL
<ul style="list-style-type: none">•Equipment•Supply Items•Publications•Software•Data

FUNDS
<ul style="list-style-type: none">•Non-appropriated•Appropriated•Revolving

In other words: all managers use data



The DoD Enterprise Model

STRATEGIC LEVEL RELATIONSHIPS

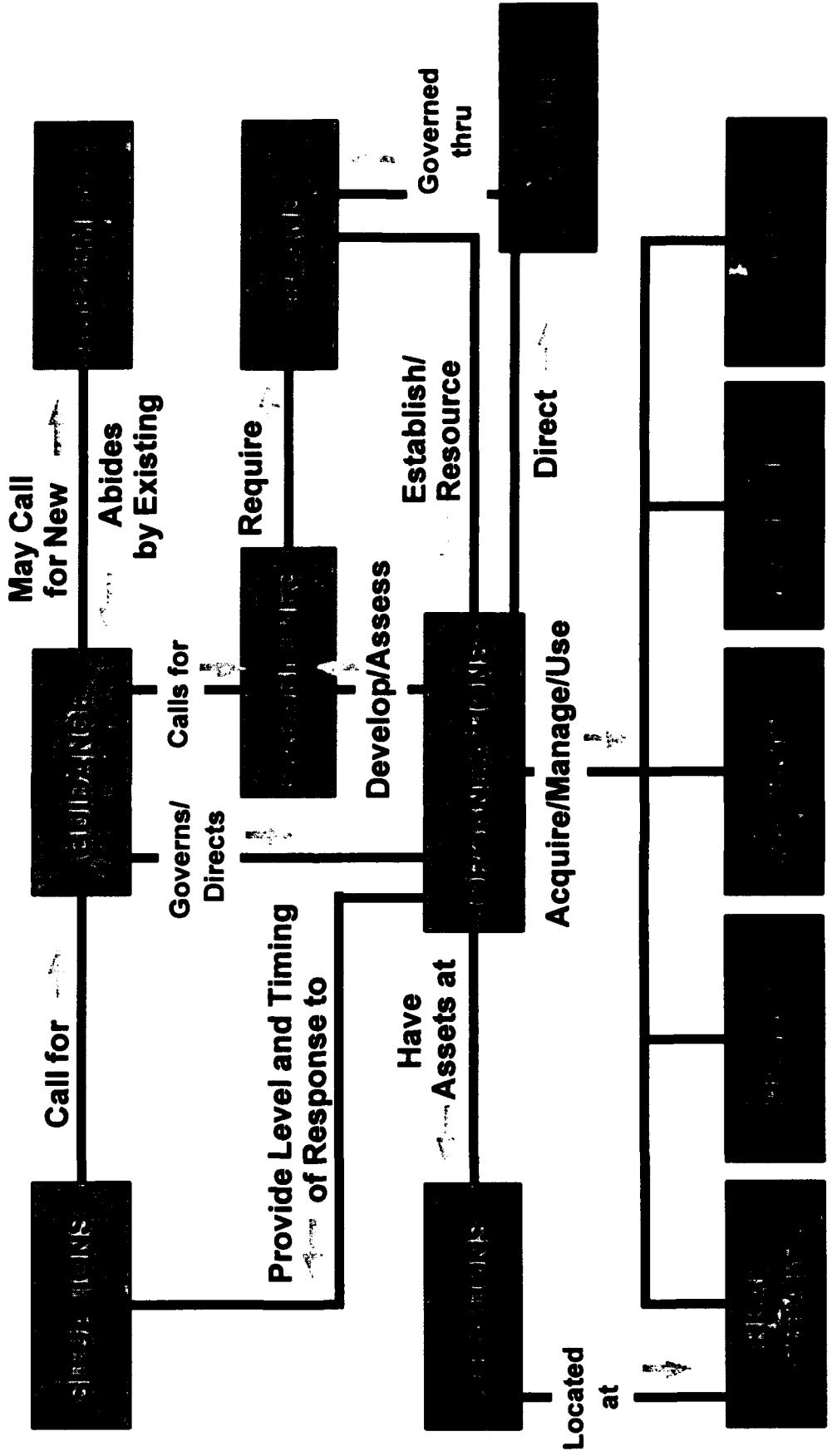



The DoD Enterprise Model

WHAT WE HAVE DONE

Aug 1992

- DoD 8020.1M - Published

Mar 1993

- 1st DoD Enterprise Model Symposium
Comments Invited on White Paper

Apr 1993

- Data/Activity Modeling Continued
- Major CIM efforts began using the
Enterprise Model

Oct 1993

- DEPSECDEF Memo on Migration
Systems and data standards

Nov 1993

- Enterprise Integration Office
Established

Jan 1994

- 2nd DoD Enterprise Model Symposium



The DoD Enterprise Model

EXAMPLES OF COMMENTS ON ENTERPRISE MODEL

- ***"We found the DoD Enterprise Model to be an excellent tool... we... believe that it is imperative that the DASD(IM) encourage all Principle Staff Assistants and the Joint Staff to use the Enterprise Model as the principal context to ensure functional process and information/data integration and standardization..." (Under Secretary of Defense (Acquisition & Technology))***
- ***"The DoD Enterprise Model white paper sets the stage for the future of the Business Process Improvement activities within DoD..." (C3I FDAAd)***
- ***"The DoD Enterprise Model... was received with great interest and expectation. Information planning and management through the discipline of information engineering principles is the only viable solution today. The DoD Enterprise Model is the initial phase of initiating such a solution in the DoD..." (Department of Navy, Naval Air Warfare Center Aircraft Division)***



The DoD Enterprise Model

EXAMPLES OF COMMENTS ON ENTERPRISE MODEL (cont'd)

- ***“We basically agree with the top level of the model. The four major processes appear valid as does the activity models and the data models.”***
(Department of Air Force, Headquarters, AFC4A)
 - ***“The United States has taken a major step towards DoD-wide data standardization in the development and wide dissemination... of a working draft DoD Enterprise Model.”***
(IDA, Systems Evaluation Division)
 - ***“Data Model provides high level sense of DoD entities and allows lower level models to be linked or integrated...”***
(Defense Finance & Accounting Service)
 - ***“We would like to commend DoD for beginning an essential but challenging task in the overarching objective to streamline the way DoD operates.”***
(Martin Marietta, Astronautics Group)
 - ***“I have reviewed the DoD Enterprise Model with great interest. I feel that it is a significant step forward towards implementing the integration objectives envisioned by government and industry.”***
(Raytheon, Equipment Division)
-



**ENTERPRISE
ACTIVITY MODEL**



The DoD Enterprise Model

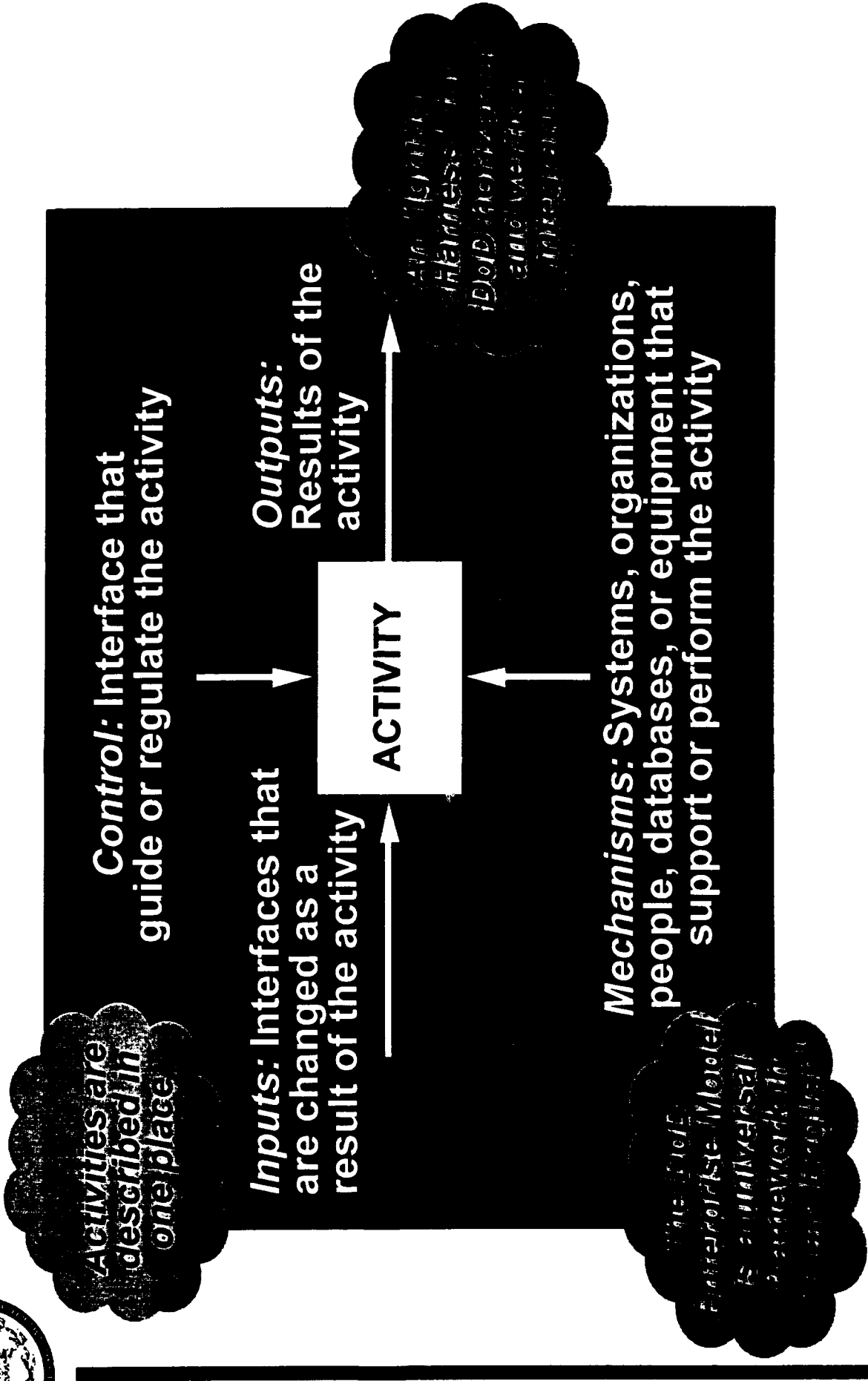

DoD Enterprise Model Overview

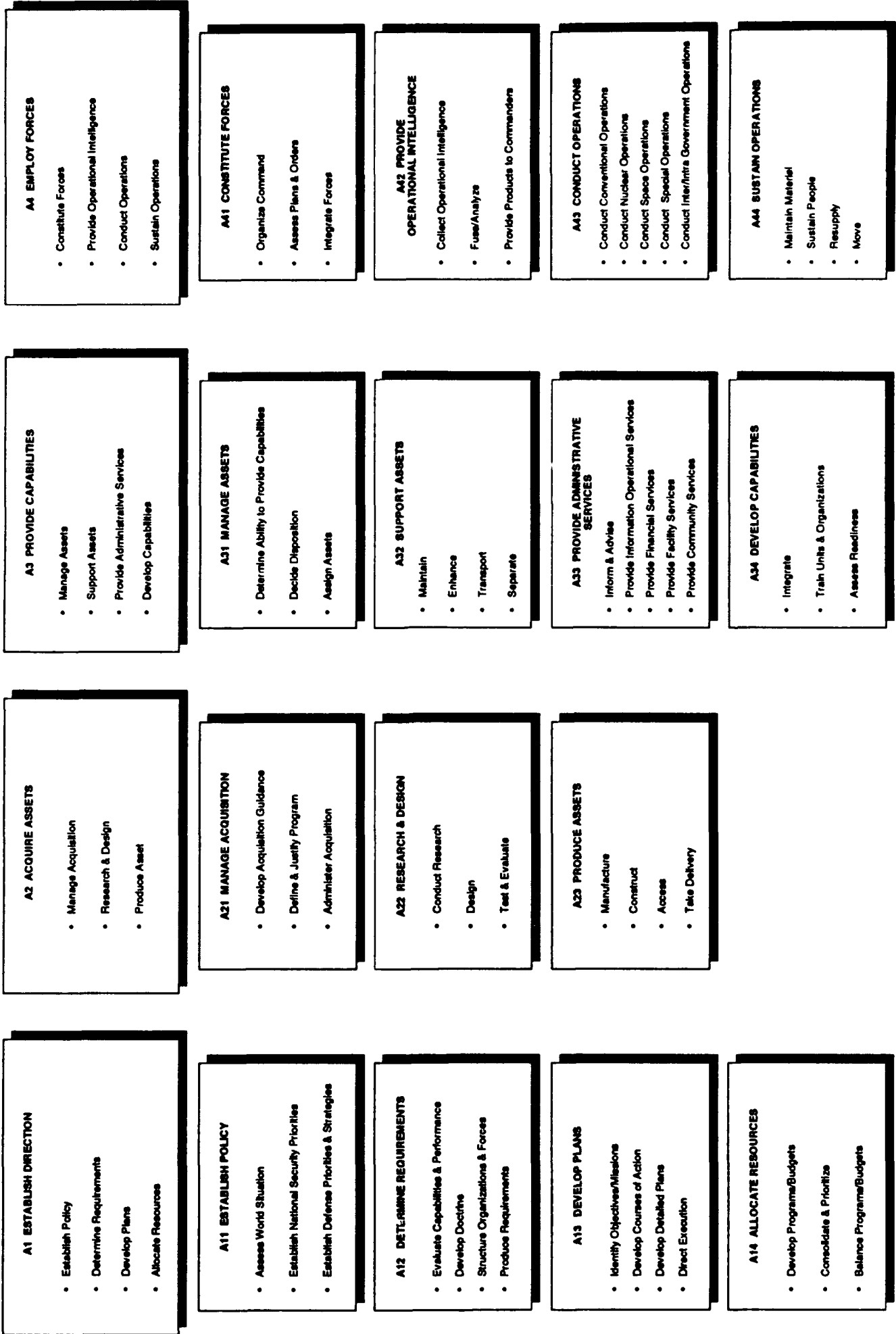



The DoD Enterprise Model





The DoD Enterprise Model

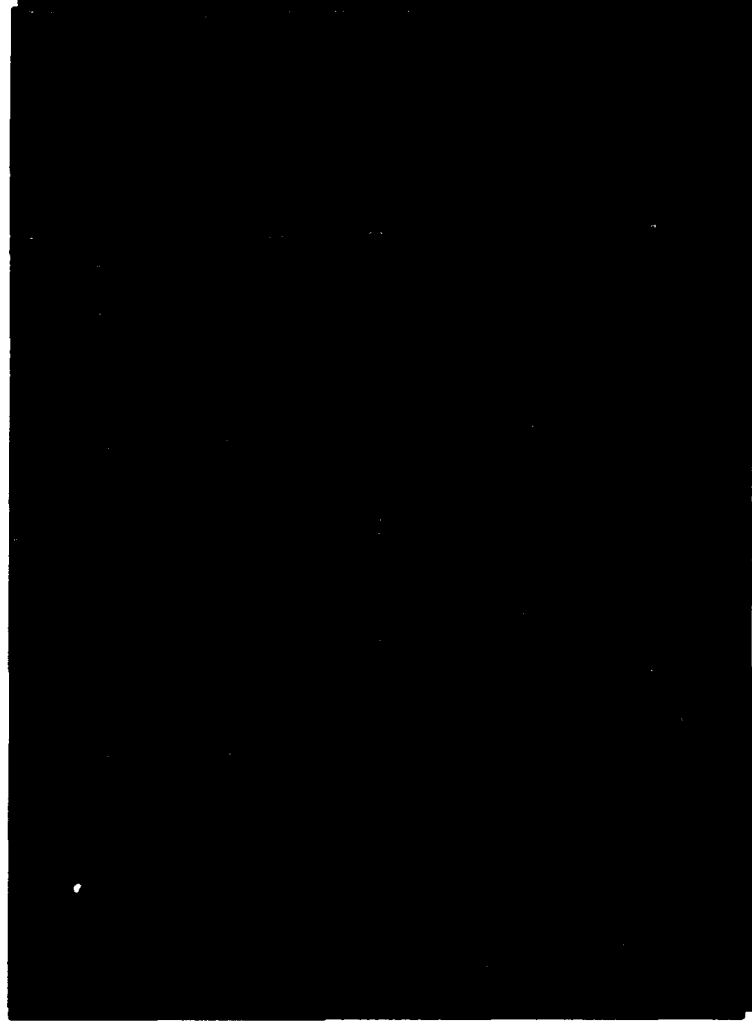



The DoD Enterprise Model

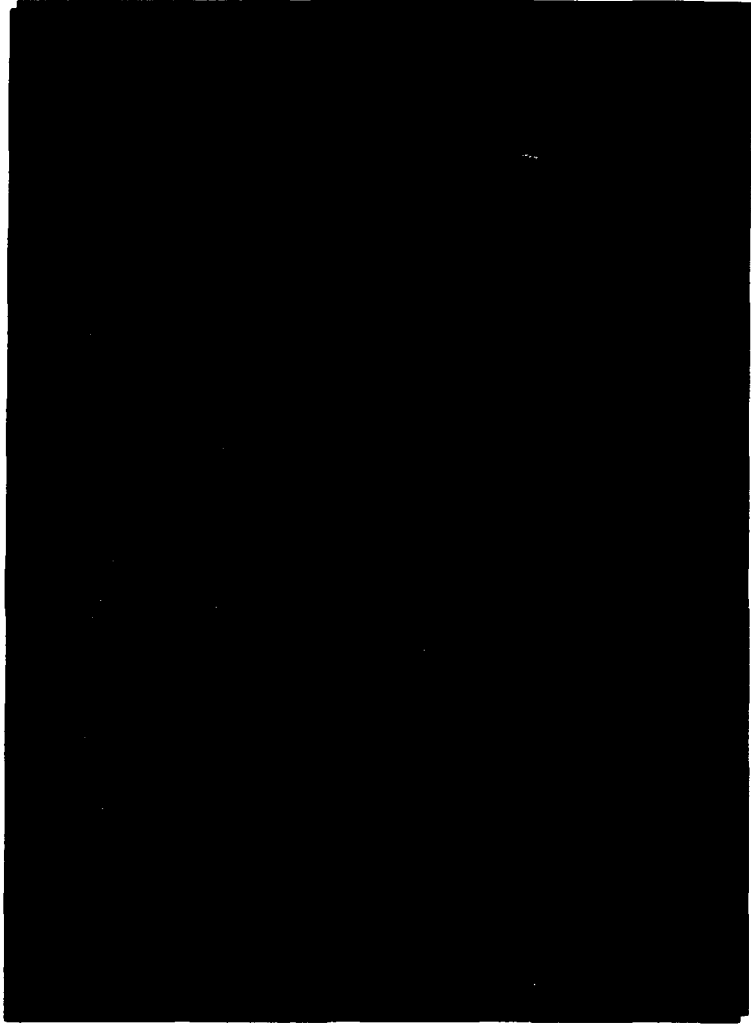



The DoD Enterprise Model

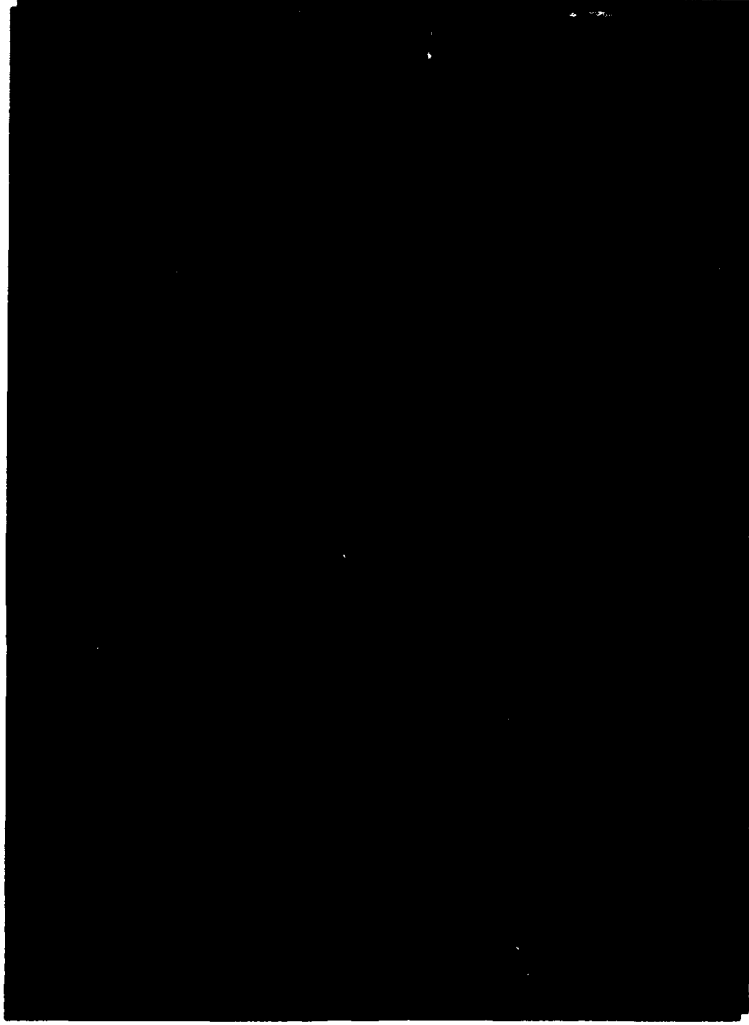



The DoD Enterprise Model

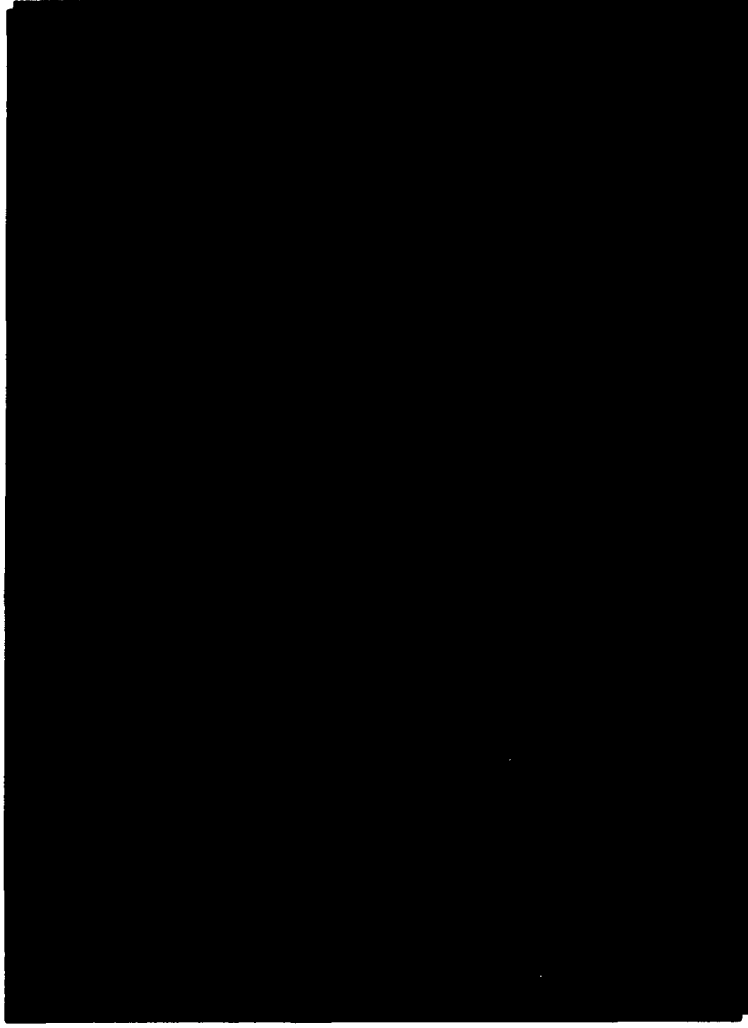



The DoD Enterprise Model

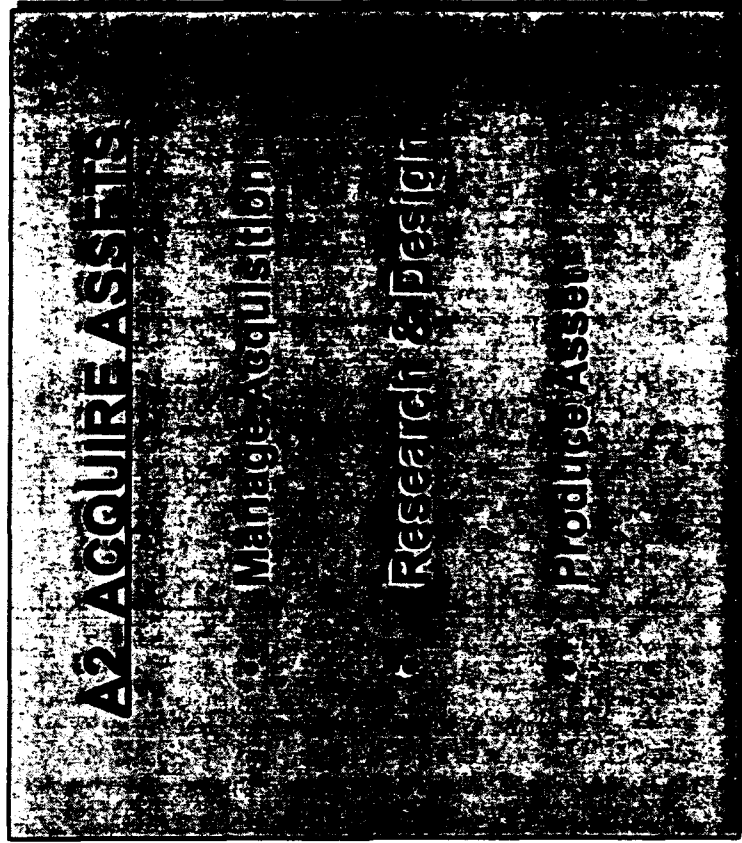

Revised



The DoD Enterprise Model

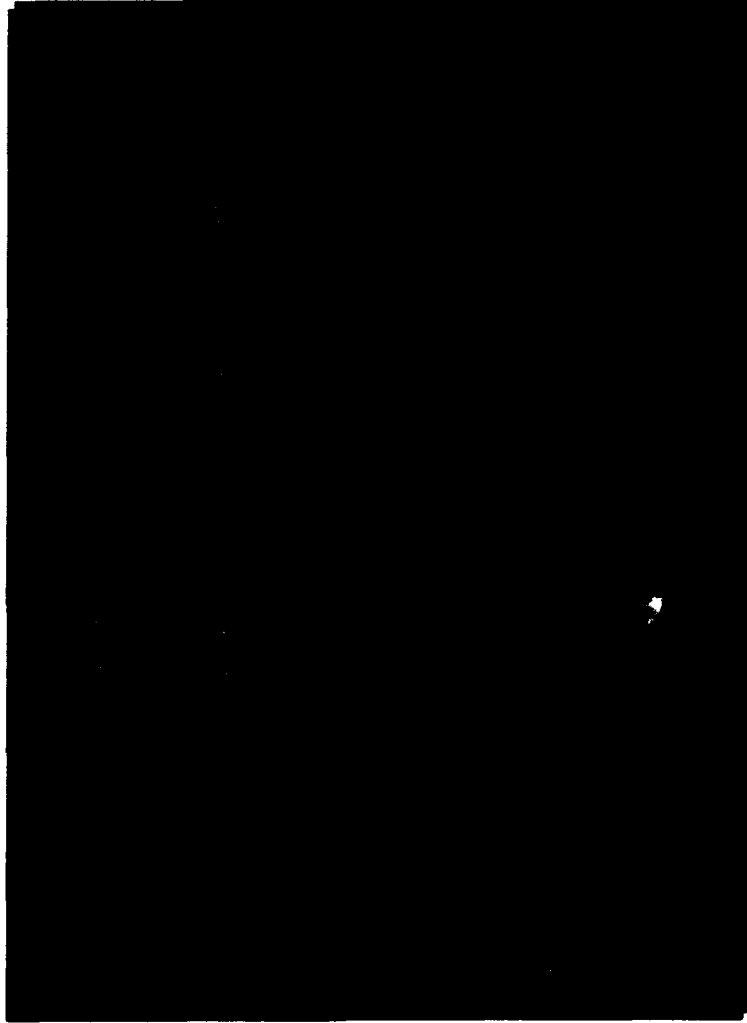



The DoD Enterprise Model

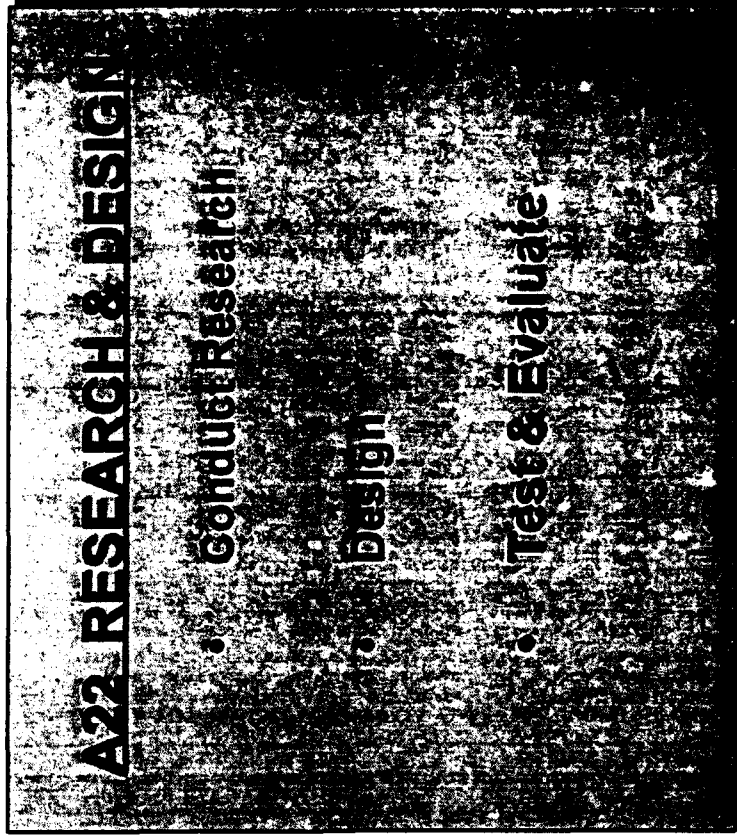
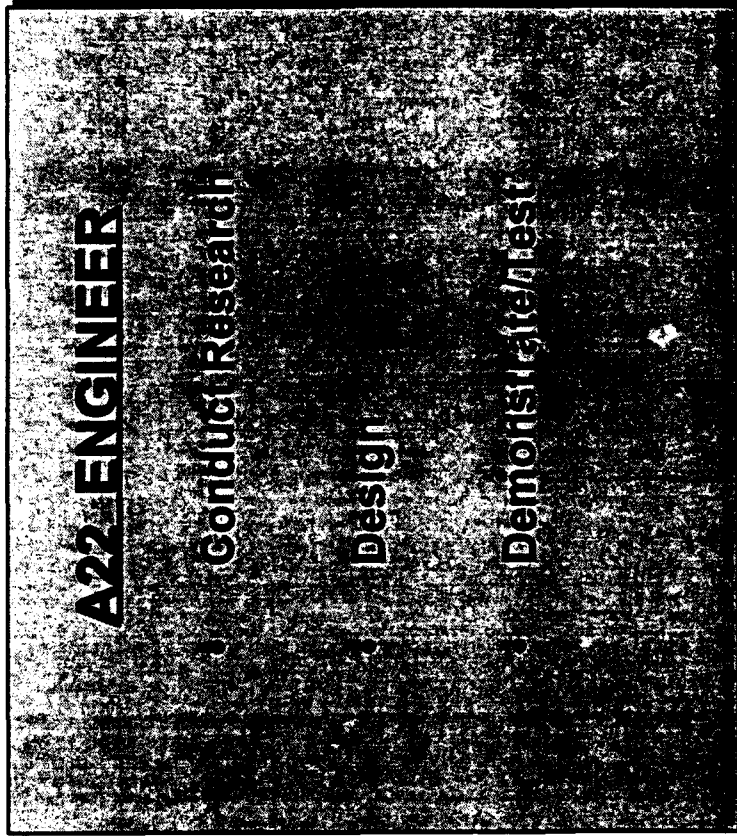

Revised



The DoD Enterprise Model

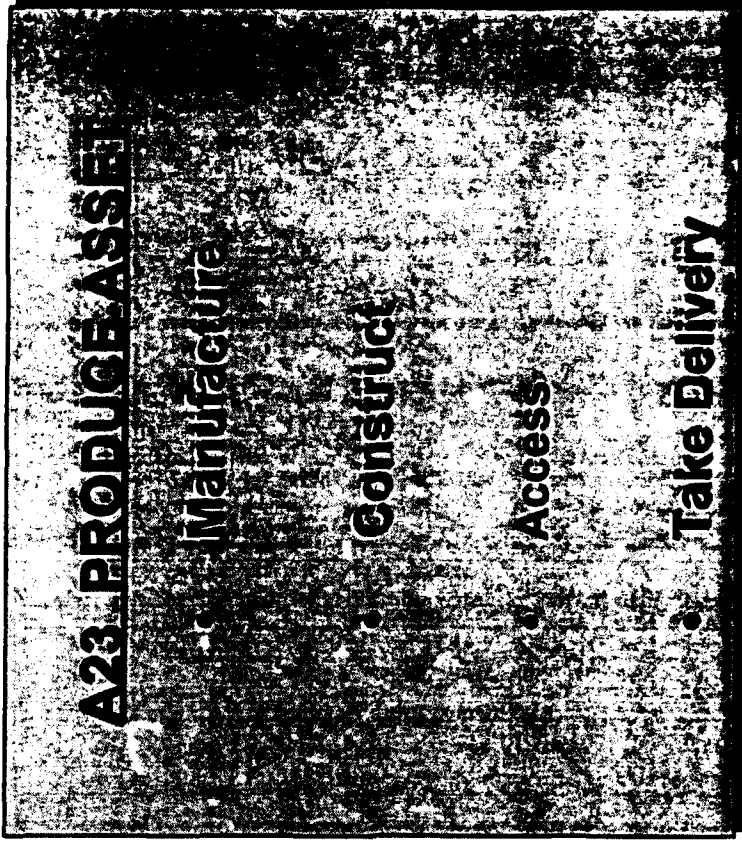

Revised



The DoD Enterprise Model

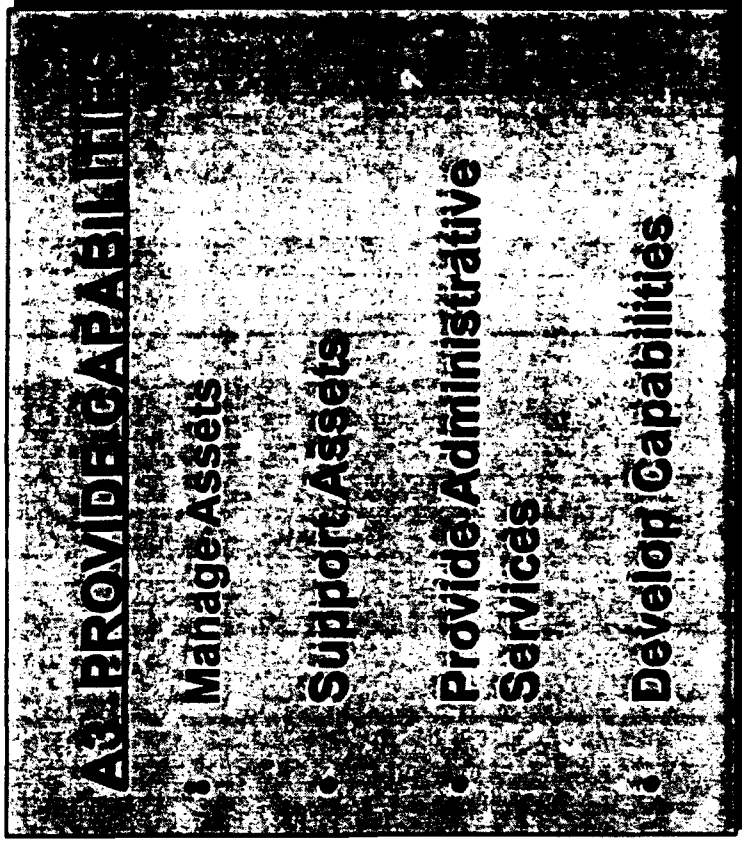
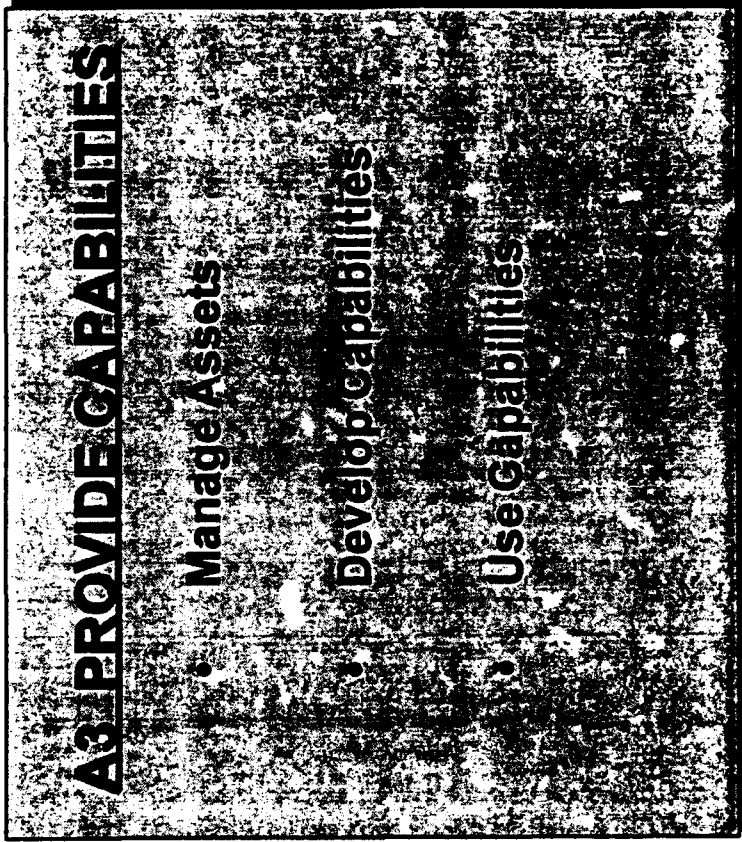

Revised



The DoD Enterprise Model

A31 MANAGE ASSETS

- Analyze Asset Requirements and Availability

- Decide Disposition

- Assign Assets

A31 MANAGE ASSETS

- Determine Ability to Provide Capabilities

- Decide Disposition

- Assign Assets

Revised



The DoD Enterprise Model

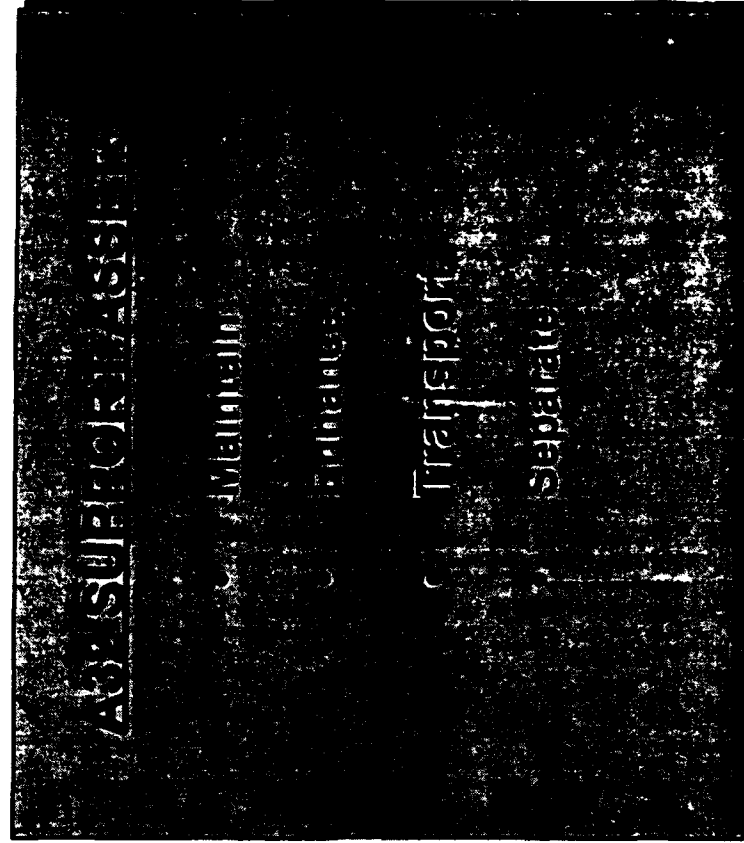
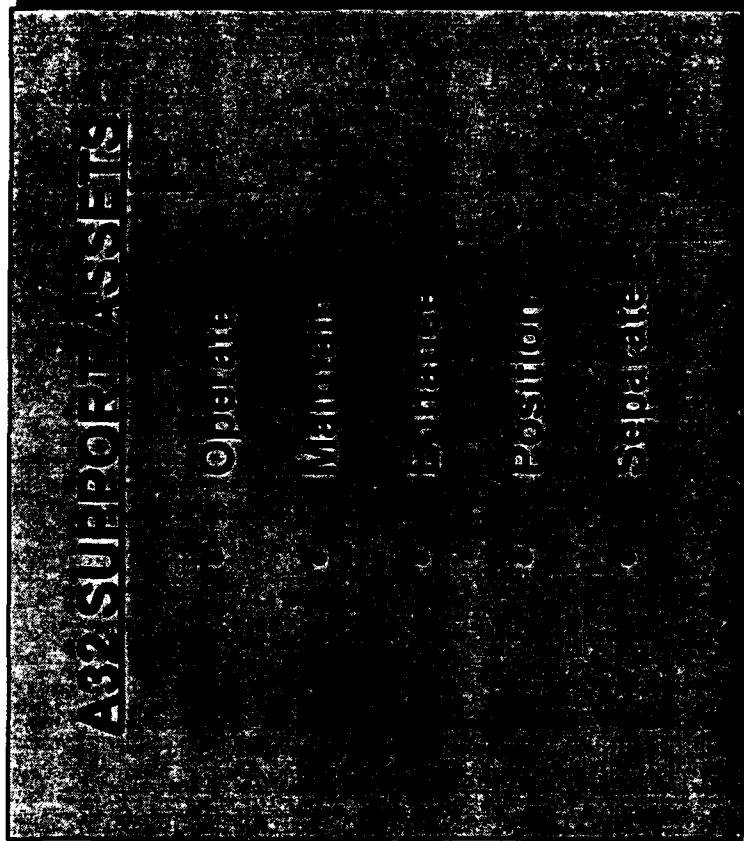

Revised

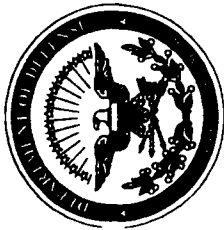

The DoD Enterprise Model

A33 PROVIDE ADMINISTRATIVE SERVICES

- Inform & Advise
- Provide Information Operational Services
- Provide Financial Services
- Provide Facility Services
- Provide Community Services

VIEW



The DoD Enterprise Model

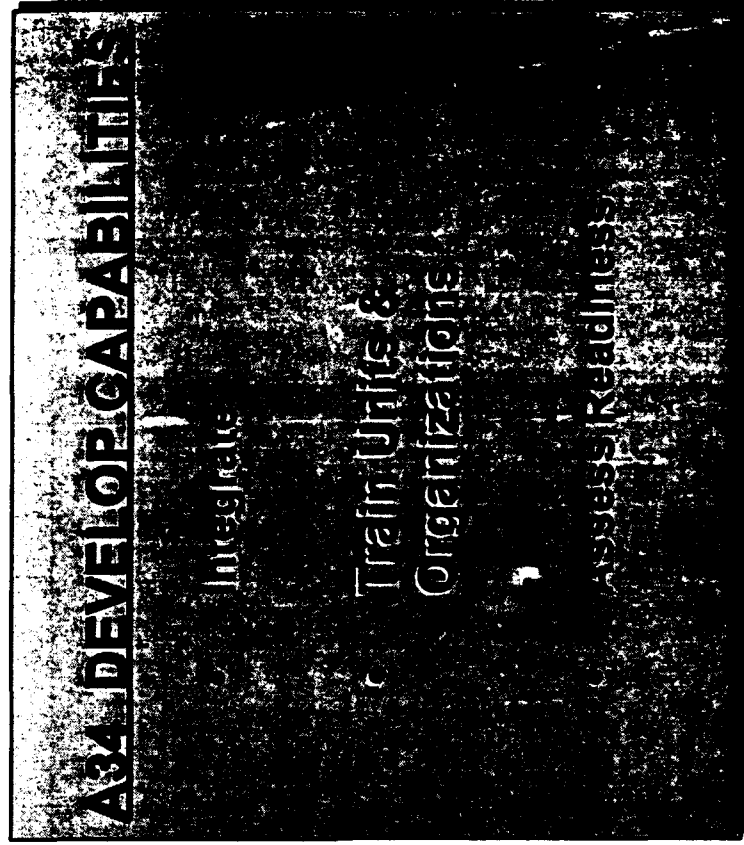

Revised



The DoD Enterprise Model

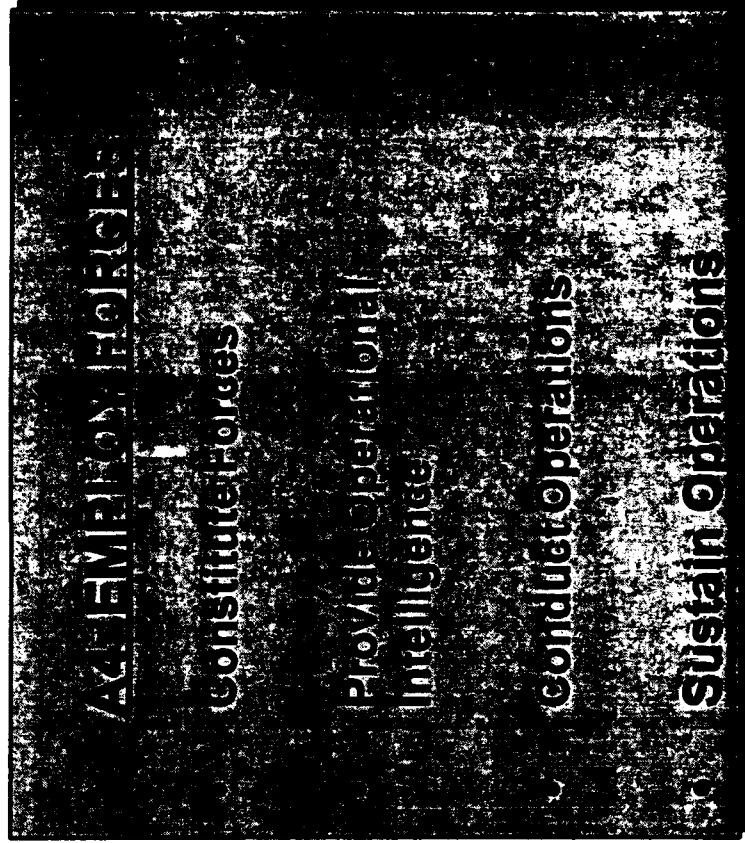
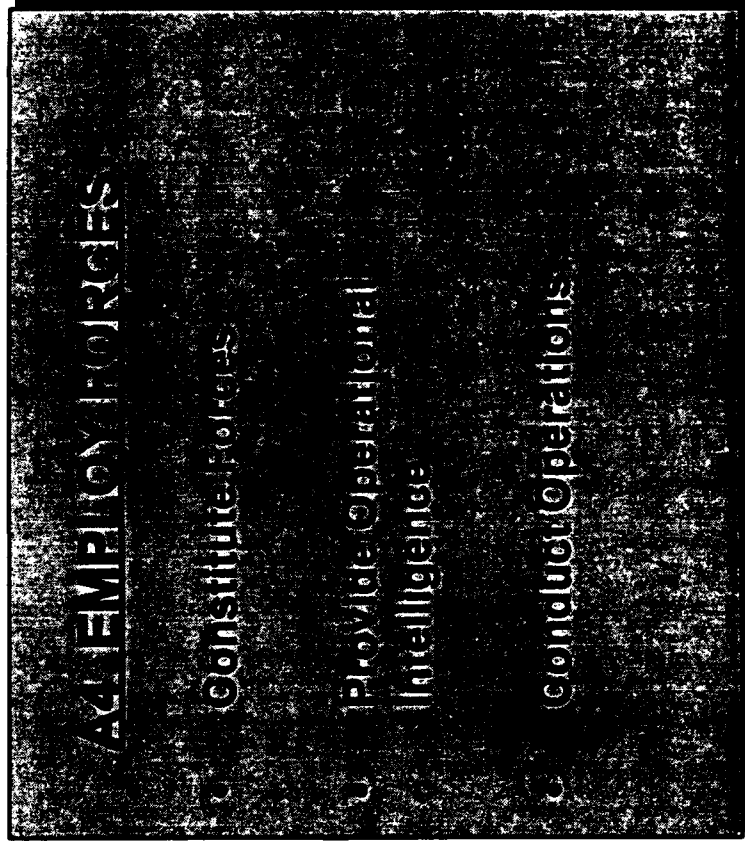

Revised

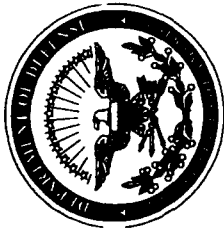

The DoD Enterprise Model





The DoD Enterprise Model





The DoD Enterprise Model

A43 CONDUCT OPERATIONS

- Conduct Conventional Operations
- Conduct Strategic Nuclear Operations
- Conduct Tactical Nuclear Operations
- Conduct Space Operations
- Conduct Special Operations
- Conduct Intra/Inter Government Operations

A43 CONDUCT OPERATIONS

- Conduct Conventional Operations
- Conduct Nuclear Operations
- Conduct Space Operations
- Conduct Special Operations
- Conduct Intra/Inter Government Operations

Revised



The DoD Enterprise Model

A44 SUSTAIN OPERATIONS

- Maintain Materiel
- Sustain People
- Resupply
- Move

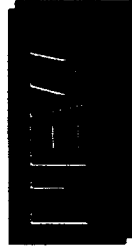



**ENTERPRISE
DATA MODEL**



The DoD Enterprise Model

PURPOSE OF THE DATA MODEL

- ***Identify and describe the data resources needed by all DoD functions and organizations***
- ***Provide a basis for validating and standardizing data elements***
- ***Guide to shared data structures in databases***

Data standards provide the GLUE that integrates processes and functions across the department



The DoD Enterprise Model

APPROACH

- ***Data Model***
 - ***Data Architecture***
 - ***Data Element Standards***
 - ***Databases***
-



The DoD Enterprise Model

DOD ENTERPRISE DATA MODEL PROCESS

- ***Model data in conjunction with activities***
 - ◆ Functional expert/data administrative teams
 - ◆ Integrated modeling project plan for activities and data
 - ◆ FDAd/CDAAd participation
 - ◆ Data Models in IDEF1X
 - ***Store IDEF1X Data Model representation in DoD repository***
 - ***Identify standard data element descriptions***
 - ◆ Validate against functional requirements/models
 - ◆ Use Data Element Standardization Procedures (DoD 8320.1-M-1)
 - ***Approve standard data descriptions for DoD repository***
-



The DoD Enterprise Model

CANDIDATE STRATEGIC LEVEL DATA ENTITIES

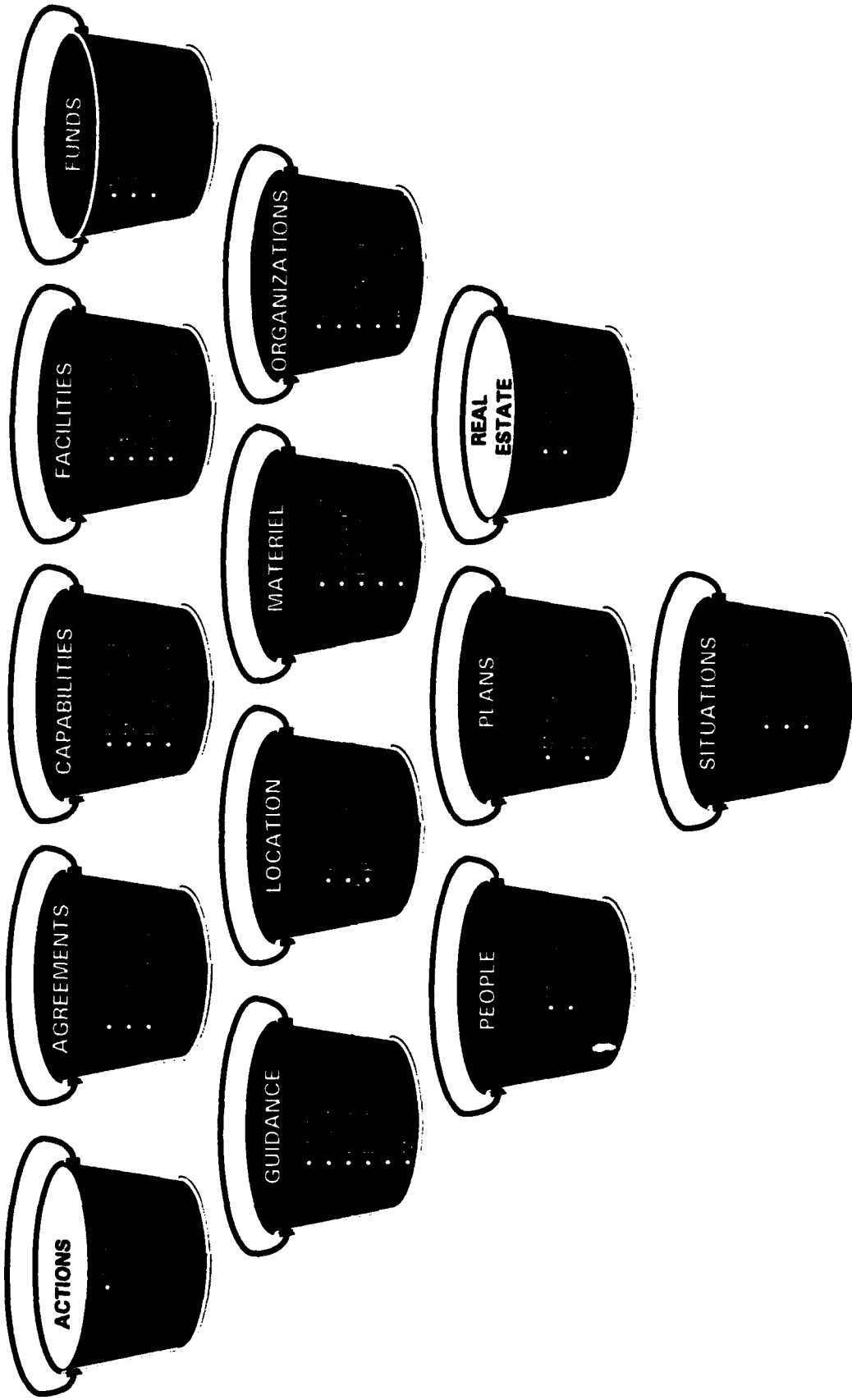



The DoD Enterprise Model

DOD STRATEGIC LEVEL RELATIONSHIPS

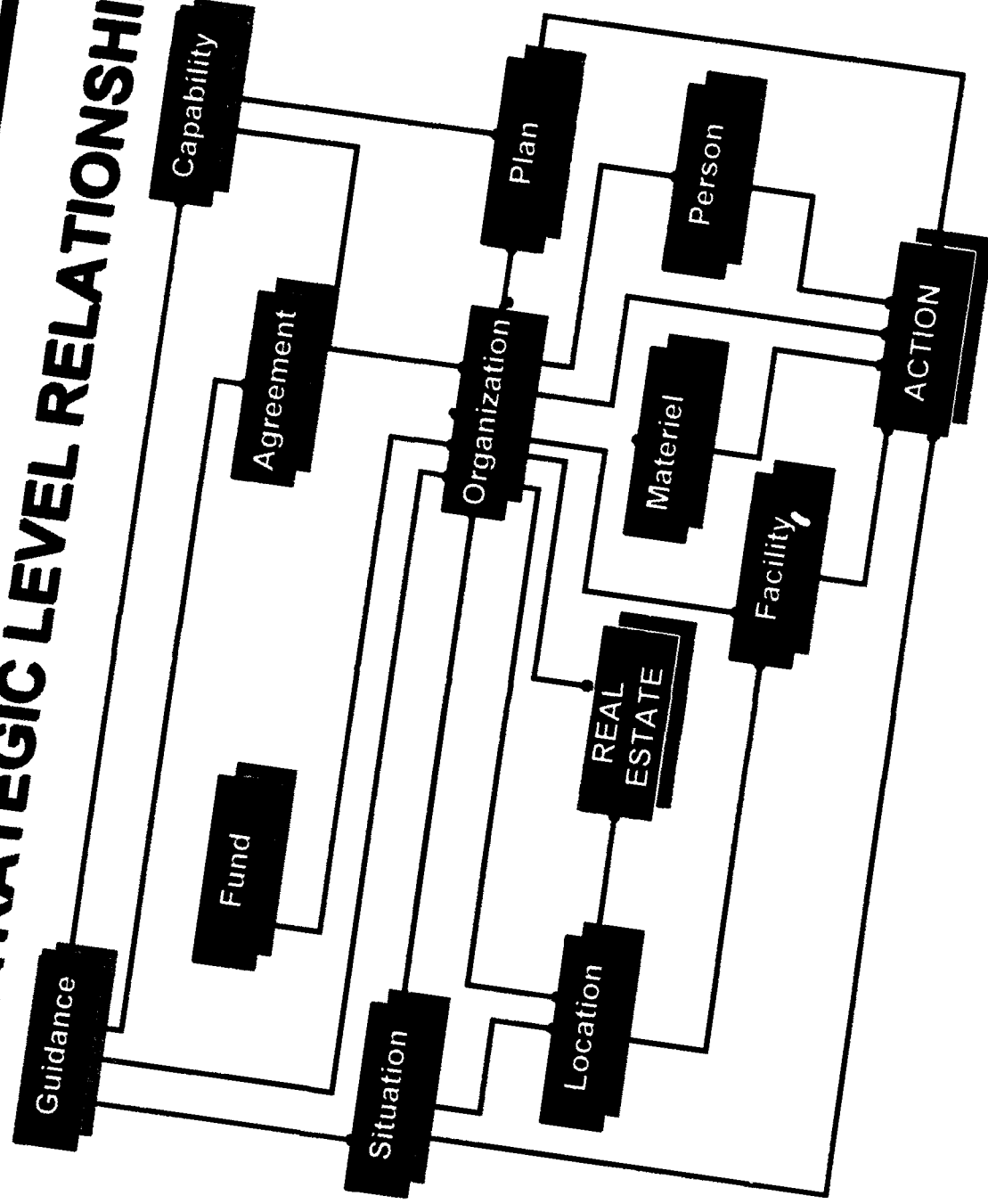



The DoD Enterprise Model

EXAMPLE ACTIVITY ANALYSIS

Activity Analysis - IDEF0

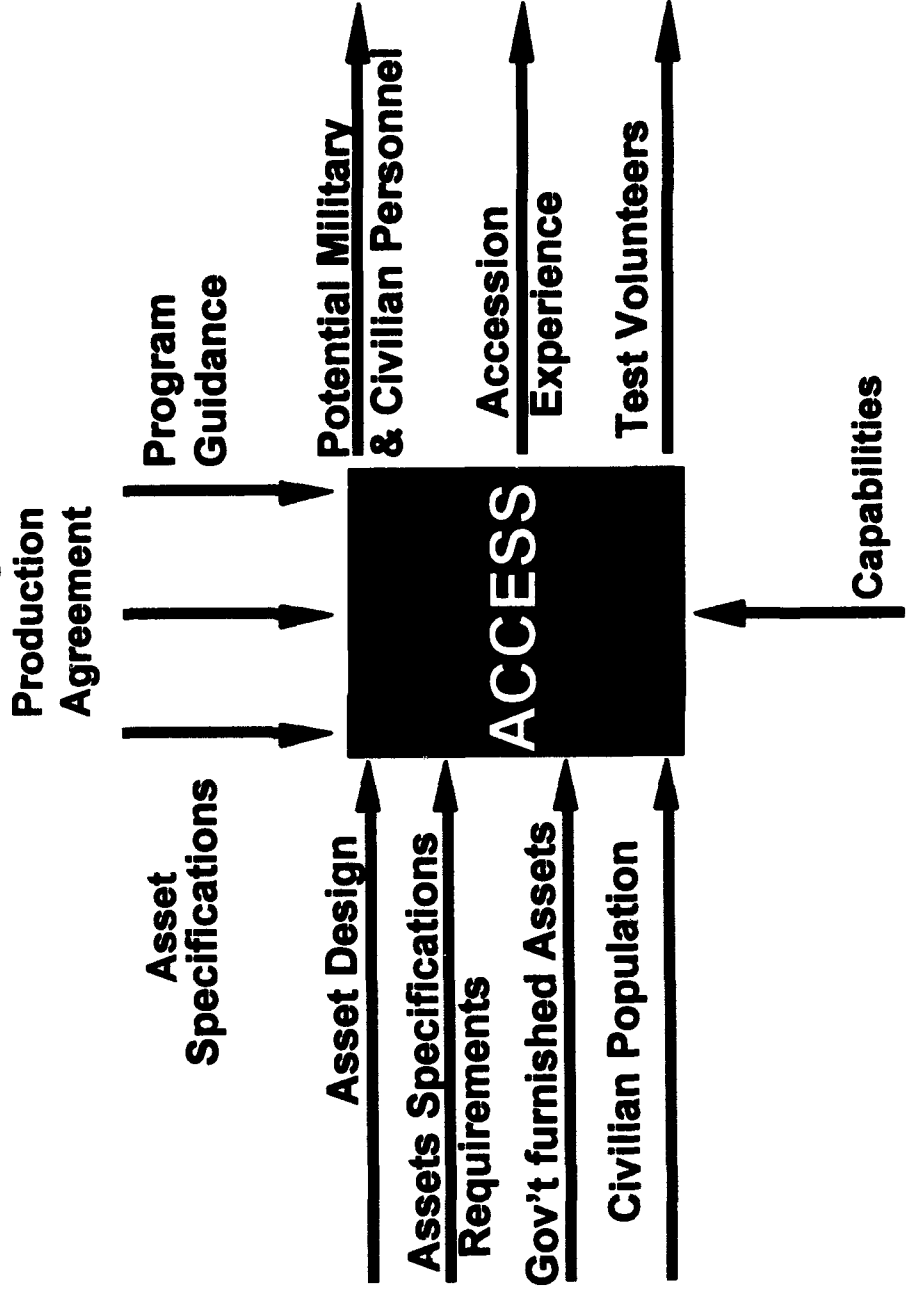



The DoD Enterprise Model

EXAMPLE DATA ANALYSIS

Data Analysis - IDEF1X

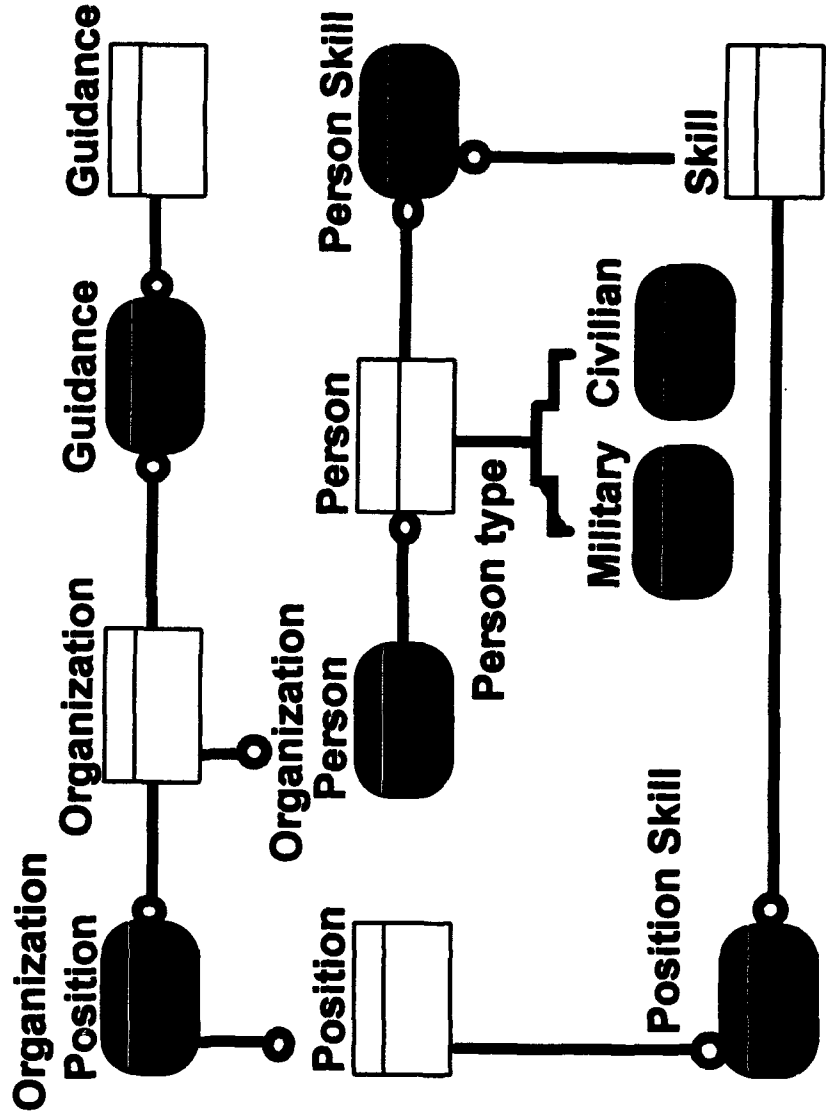



The DoD Enterprise Model

KEY CHANGES FROM FEBRUARY 1993 DRAFT

- **"Action" added as strategic data entity**
 - ◆ Satisfies C² and Acquisition requirements
 - ◆ NATO ATCCIS Generic Hub Data Model used as basis for integration effort
 - **"Real Estate" strategically related to "location"**
 - **Section 6**
 - ◆ Senior Management View
 - ◆ Guidance to Functional Areas on Data Modelling
 - ◆ Mechanism for Integration
 - ◆ Glossary of Common Terms updated
 - **Appendix C**
 - ◆ Tutorial material on IDEF1X added
 - ◆ Diagrams and Examples updated
 - ◆ Examples of Functional Area use of Strategic Data Model added
 - **Appendix D**
 - ◆ Data Entity definitions updated
 - ◆ Definition of Attributes added
-



The DoD Enterprise Model

DATA ADMINISTRATION AND THE CIM MODEL

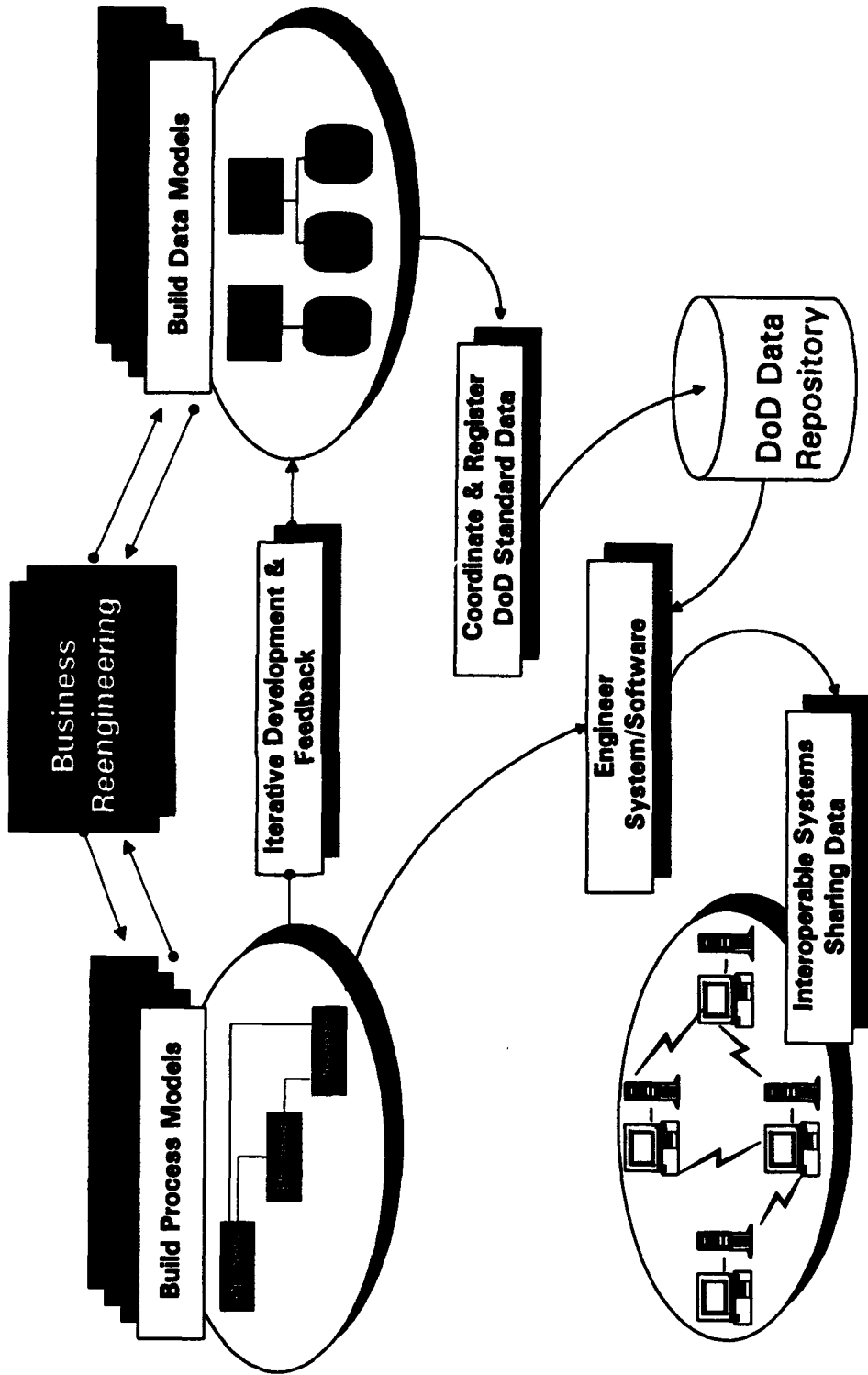



BLUEPRINT FOR INTEGRATION

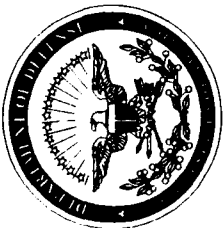

The DoD Enterprise Model

THE DoD "CONUNDRUM": HOW TO INTEGRATE THE ENTERPRISE?

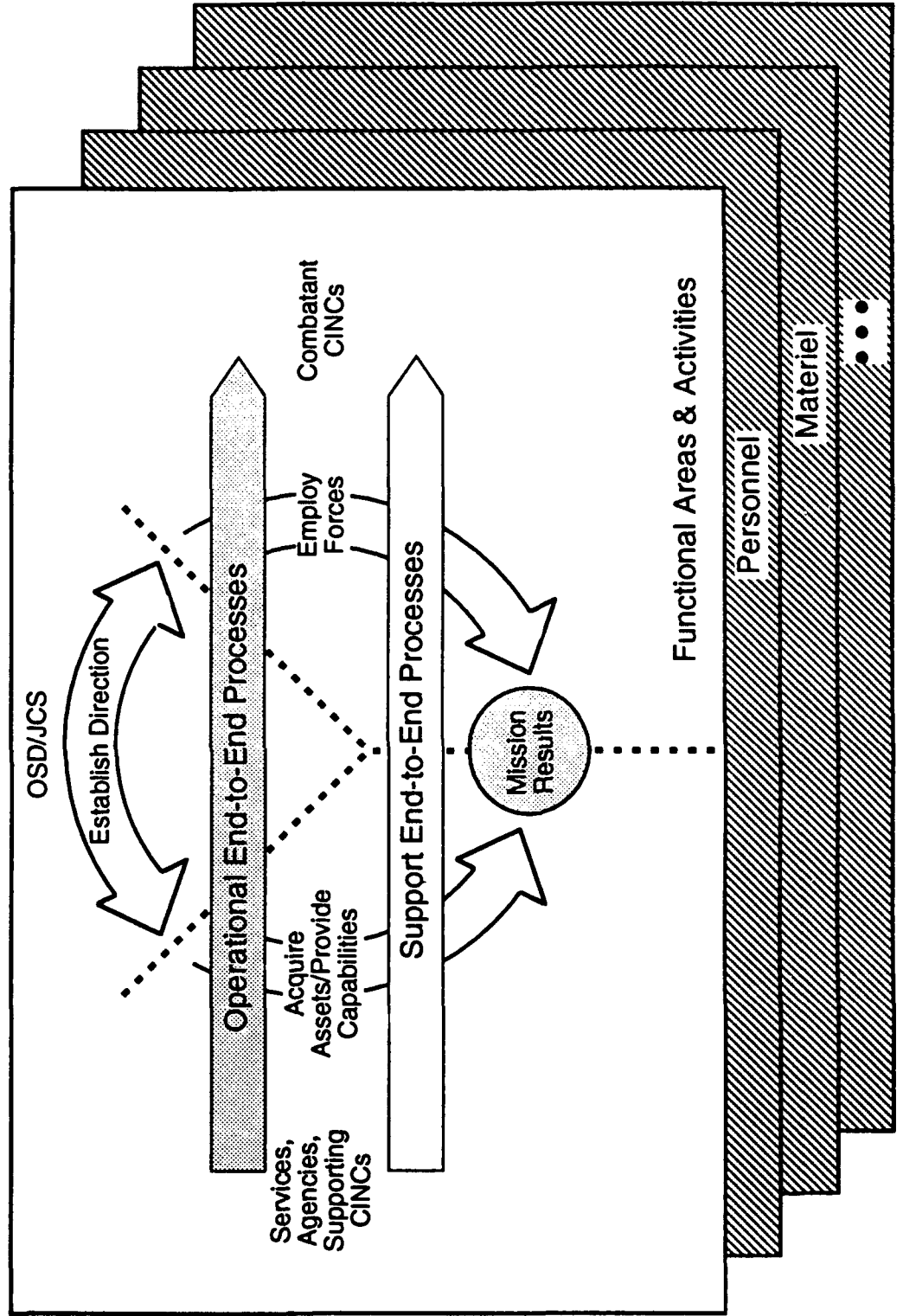



The DoD Enterprise Model

DoD ENTERPRISE INTEGRATION

A Corporate Approach

- ***Planning Strategically and Top Down***
 - ***Taking a DoD Enterprise Perspective on All Activities***
 - ◆ ***Aligning the Enterprise Around End-to-End Core Processes***
 - ***Eliminating Duplication and Bottlenecks Aggressively***
 - ***Sharing Resources Among Organizations/Reusing Assets***
 - ***Shifting Resources Into More Productive Activities***
 - ***Evaluating Processes and Outcomes Continually to Improve Defense***
-



The DoD Enterprise Model

ENTERPRISE INTEGRATION OUTCOMES

- ***Enhanced Capability to Respond to Crises***
- ***Seamless Interface Between Front Line & Support Infrastructures***
- ***Just-in-Time Delivery of DoD Goods and Services***
- ***Total DoD Asset Visibility & Management***
- ***Improved Customer-Supplier Links***
- ***Wholesale-Retail Integration***
- ***Enhanced US Industry Competitiveness***





The DoD Enterprise Model

APPLY THE CORPORATE IMPROVEMENT PROCESS

- **Guide changes from DoD-wide perspective by the collective senior leadership**
- **Change methods, organizations, and resources; including policy, culture, and practices using the DoD Enterprise Model to manage cross-functional impacts**
- **Re-align around “End-to-End” Core Processes, remove constraints on time, reduce costs, and improve quality**
- **Capitalize on DoD-wide improvements that:**
 - ◆ **Remove policy barriers**
 - ◆ **Empower employees**
 - ◆ **Add Flexibility**
 - ◆ **Manage Risk**

Improvement requires a total commitment to re-inventing policies, organizations, people, culture, processes, resources, and systems. Isolated changes to one or another element of the enterprise inevitably fails to achieve overall goals.



The DoD Enterprise Model

CORPORATE IMPROVEMENT PROCESS

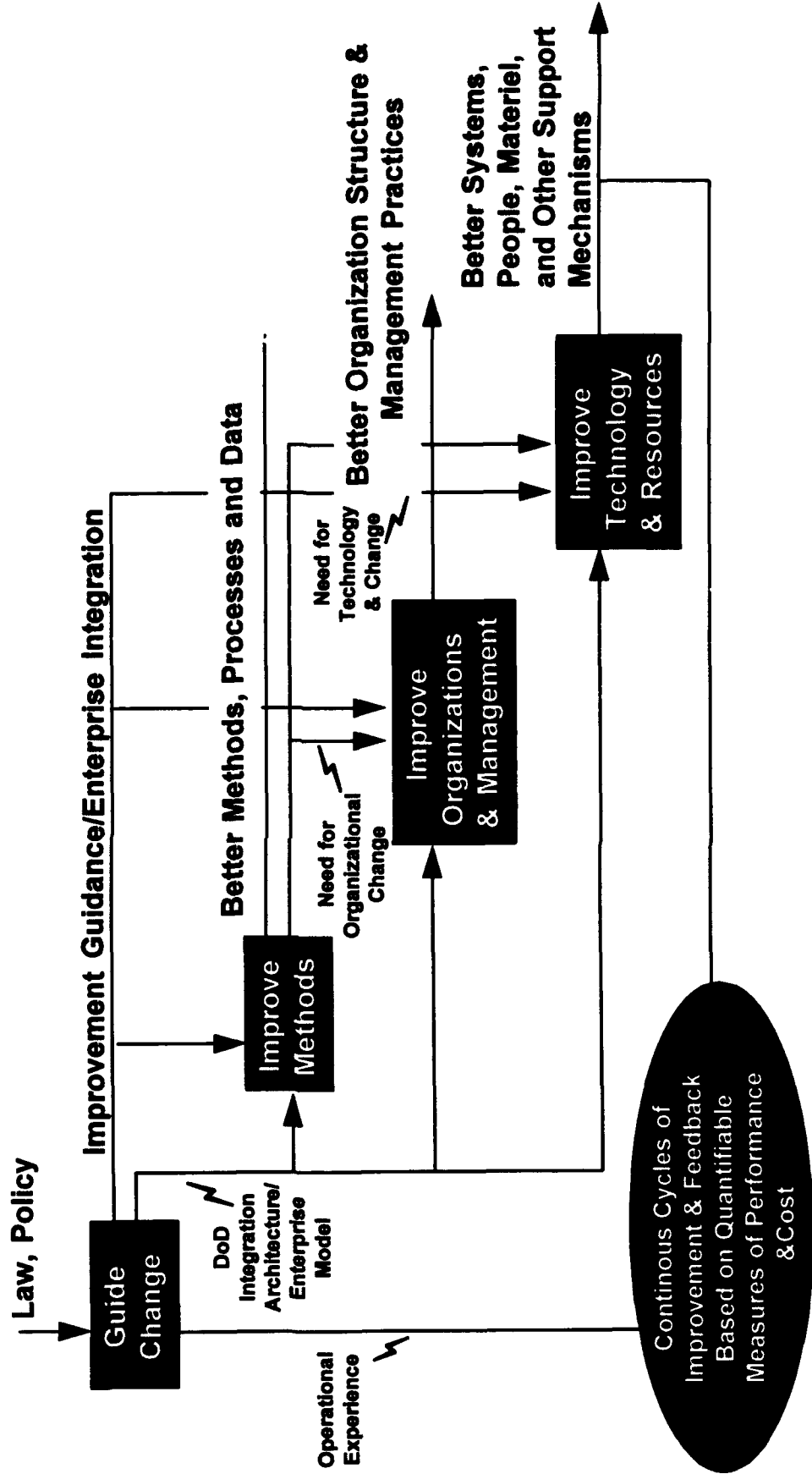

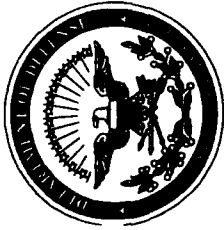

The DoD Enterprise Model

DoD INTEGRATION ARCHITECTURE

- *Provides the “terrain map” for DoD improvement*
 - ◆ *Addresses all elements of the DoD Enterprise*
- *Deployed consistently at all echelons*
 - ◆ *DoD-wide, functional area, functional activity, and below*
 - ◆ *Nested set of DoD values, policies, plans, structures, processes, data, resources and technology*
- *Provides framework for links to external environment*
 - ◆ *Other Federal Agencies*
 - ◆ *Allies and coalition partners*
 - ◆ *Industry*
- *Enables horizontal integration between elements and vertical integration across levels*



The DoD Enterprise Model

Provide for the Common Defense

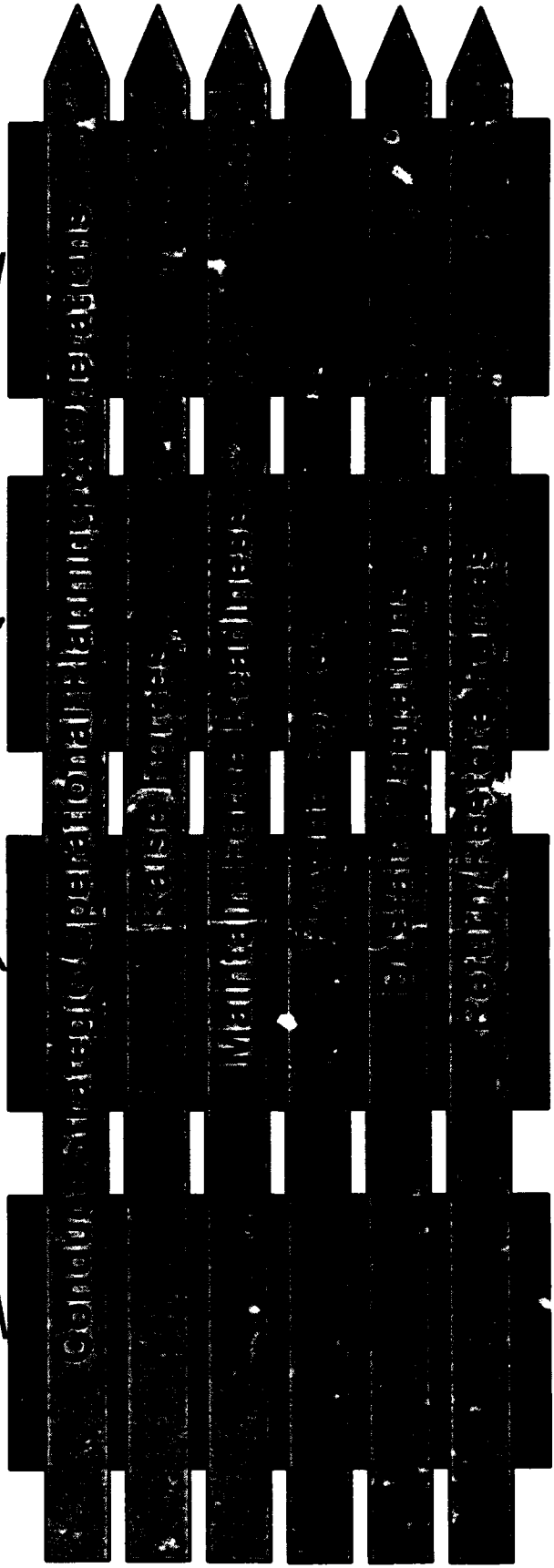

**Establish
Direction**

**Acquire
Assets**

**Provide
Capabilities**

**Employ
Forces**

CANDIDATE DOD CORE PROCESSES



IDENTIFY NEEDS OF CUSTOMERS & CONSUMERS

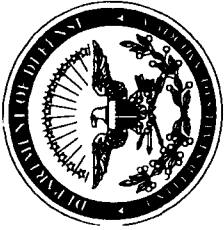

The DoD Enterprise Model

ESTABLISH KEY CUSTOMER/CONSUMER ROLES

- ***CINC - “consumer”*: What will I need to get to accomplish my assigned mission, and how much can I afford to spend relative to my total needs?**
 - ***Joint Staff - “surrogate”*: What is the aggregate demand on the sustaining base, and the recommended priorities and sequencing?**
 - ***OSD - “customer”*: What must DoD do to deliver affordable, relevant quality products and services when and where they are needed? What must consumers see to make sure the sustaining base meets their mission needs?**
-



The DoD Enterprise Model

MAKE THE ENTERPRISE WORK FOR THE "WARFIGHTER"

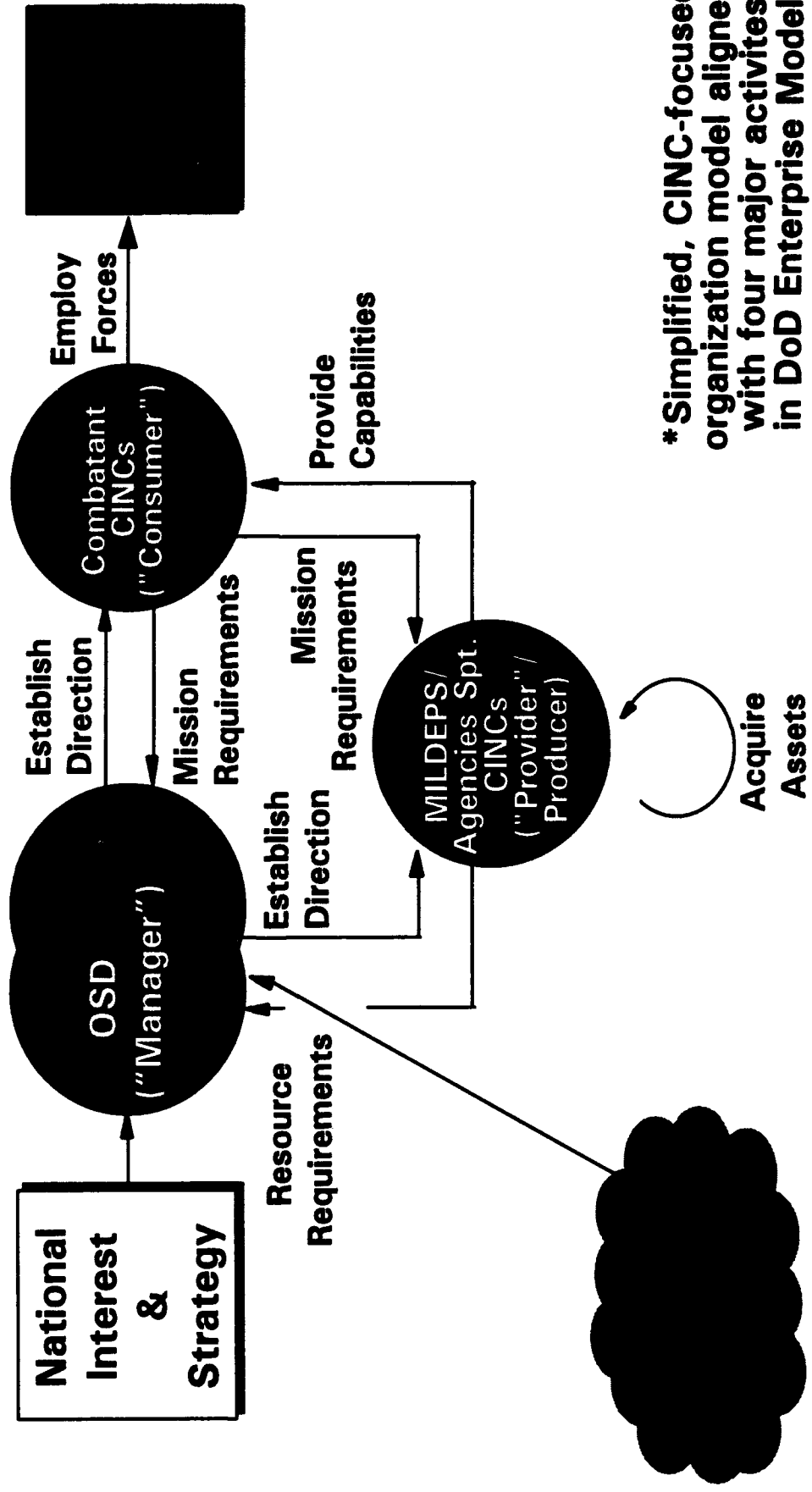

*Simplified, CINC-focused organization model aligned with four major activities in DoD Enterprise Model



The DoD Enterprise Model

IDENTIFY DEMANDS ON THE SUSTAINING BUSINESS BASE

- ***Operational requirements for units, people and equipment***
 - ***Number of units/people/equipment to be supported and turnover (e.g., casualties, rotation)***
 - ***Location - distance and lift***
 - ***“OPTEMPO” - intensity & environmental factors (e.g., climate)***
 - ***Duration of operations & resupply capability***
 - ***Physical infrastructure, (e.g., constraints of immature theater)***
-
- 



The DoD Enterprise Model

EMPLOY FORCES/ESTABLISH DIRECTION DETERMINE REQUIREMENTS

- ***Must determine:***
 - ◆ **Delta between operational need and current/planned capability**
 - ◆ **Doctrine**
 - ◆ **Force structure**
 - ◆ **Equipment, people, support**
 - ***What critical “Employ Forces” activities must be considered in “Establish Direction”, and what should be visible to sustaining base managers & providers?***
-



The DoD Enterprise Model

EMPLOY FORCES/ESTABLISH DIRECTION DRIVES ACQUIRE ASSETS

- **Requirements and approved programs drive acquisition of:**
 - ◆ Equipment
 - ◆ People
 - ◆ Parts (sustaining & war reserve)
 - ◆ Facilities
 - ◆ AIS
 - ◆ etc.
 - **“Employ Forces/Establish Direction” should have sufficient detail and ops context to drive expanded JROC-type analysis of DoD acquisition vs. JTF requirements**
 - **OR**
 - **JTF “adapts” to what it gets from “Acquire Assets”**
-



The DoD Enterprise Model

EMPLOY FORCES/ESTABLISH DIRECTION DRIVES PROVIDE CAPABILITIES (PLANS) & EMPLOY FORCES DRIVES PROVIDE CAPABILITIES (EXECUTION)

- ***“Employ Forces” drives:***
 - ◆ ***Management of assets***
 - ◆ ***Development of capabilities***
 - ◆ ***Use of assets***
- ***To have the right combination of the right “stuff” in the right places to meet assigned mission needs,***

OR
- ***To have the right visibility of current status to make best decision on who/what must go into the AOR to meet mission demand***



The DoD Enterprise Model

CHANGE PROCESS & FUNCTIONS

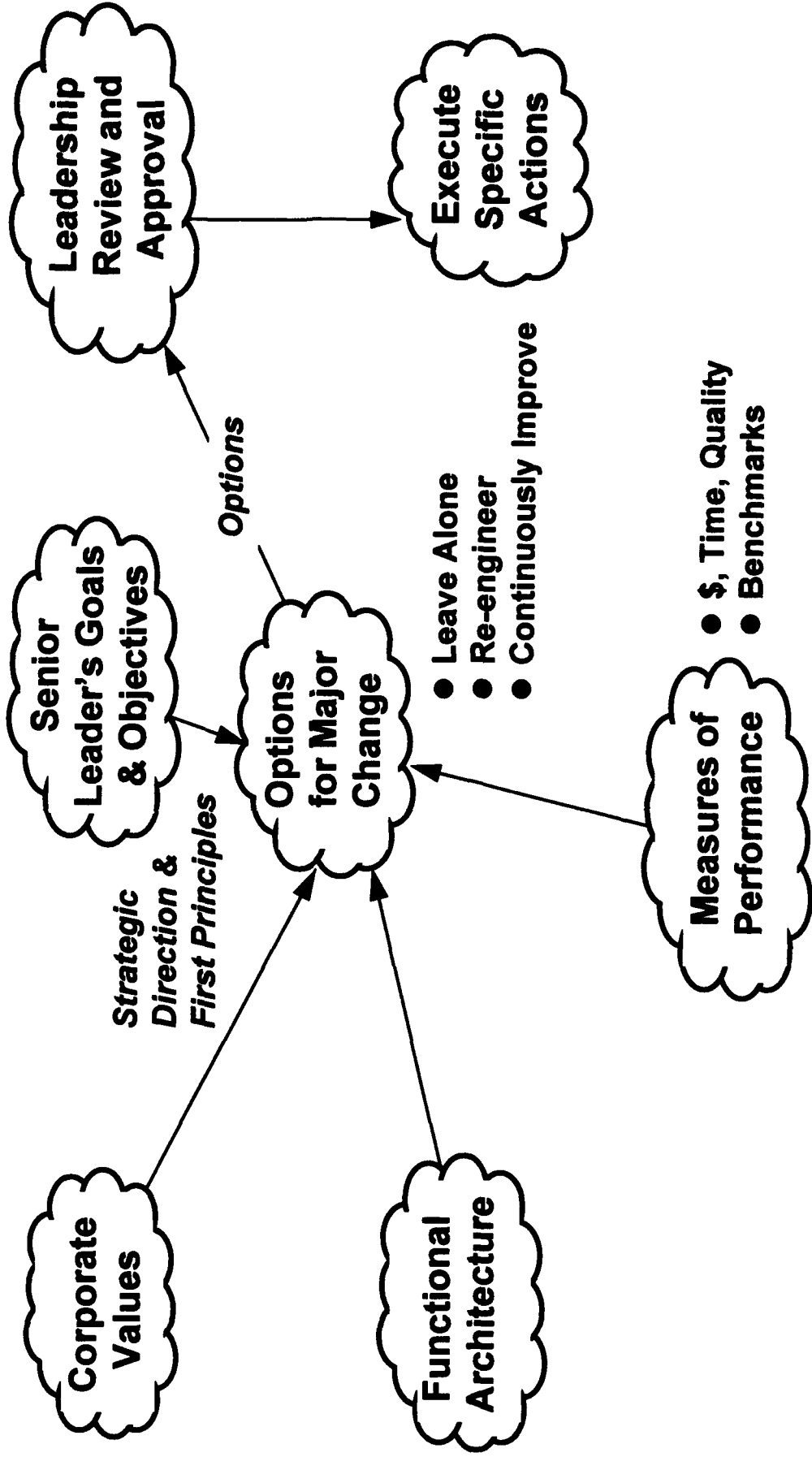



The DoD Enterprise Model

ESTABLISH DoD PERFORMANCE AND COST MEASURES - FROM CONSUMER/CUSTOMER NEEDS

- *Used to direct change and evaluate progress*
- *Consistent with Government Performance and Results Act (GPRA) and NPR recommendations*
- *Optimize vertical "efficiency" and horizontal "effectiveness" across DoD Enterprise activities*
- *Emphasize outcomes and consumer/customer satisfaction*
- *Show the return-on-investment of cross-functional, end-to-end process initiatives, e.g.;*
 - ◆ *Sustainment for the forces in the field*



ENTERPRISE ORGANIZATIONAL & CULTURAL CHANGE



The DoD Enterprise Model

ORGANIZATIONAL INTEGRATION METHOD

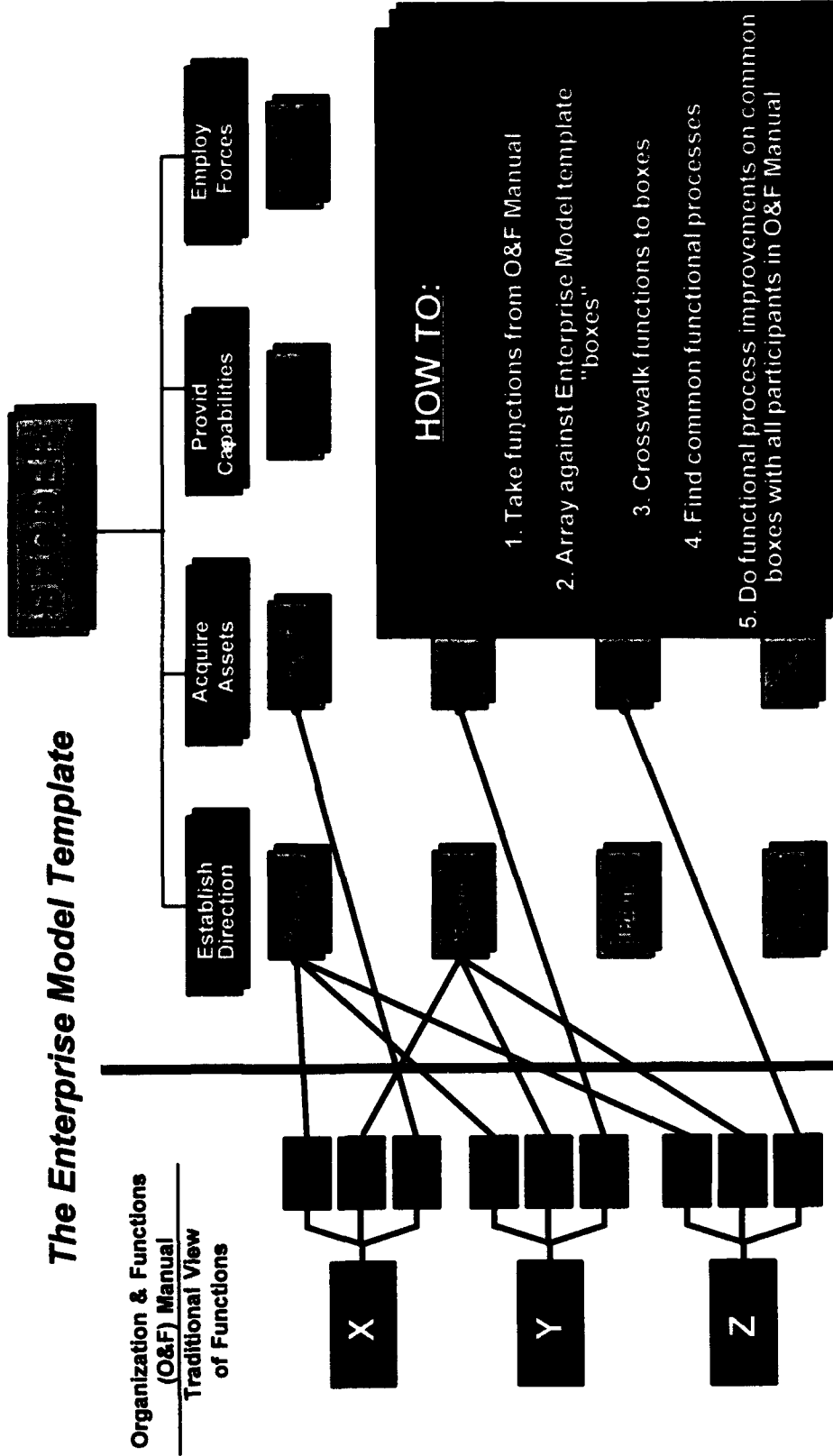



The DoD Enterprise Model

**LINK PROCESS IMPROVEMENTS TO DoD
VALUES/REWARDS**

In order to...

- ① Make Change happen through the actions
and behavior of people**
- ② Imbed standards (performance measures) in
individual and organizational performance**



The DoD Enterprise Model

- Policy fragmented
- Missions not clear and focused
- Values stifle initiative and change
- Culture of Innovation and Improvement not institutionalized

- Methods suboptimized across the Department
- Organization structures not aligned with better methods

- Measures lacking, too low-level, or not used
- Measures not tied to goals & objectives
- Performance measurement system doesn't focus organizations and reward people for implementing improvements

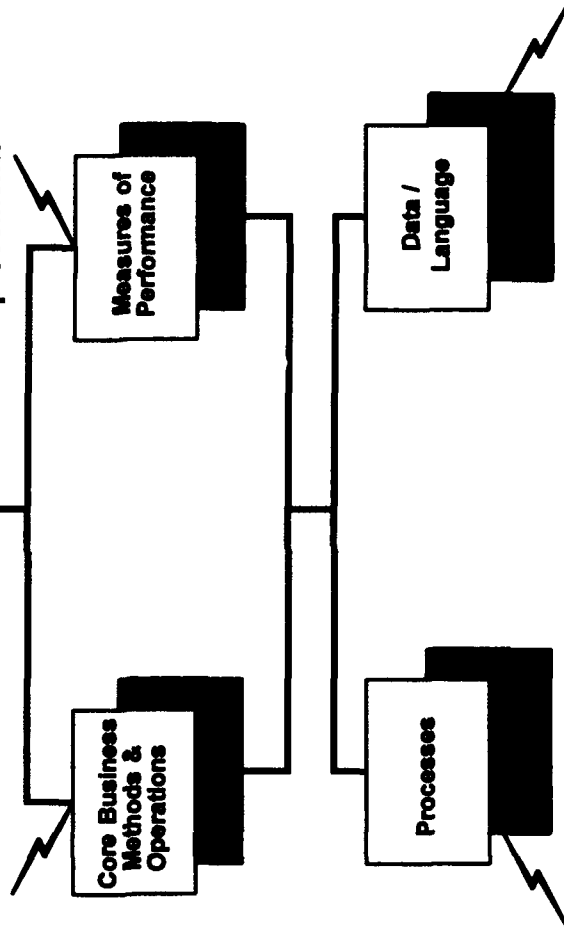

- Key "end-to-end" driver processes not identified, or managed
- Customers and consumers needs not linked to processes
- Standards not imbedded in job descriptions & rewards

- Key data not standardized
- Standard data not imbedded in DoD "language" & "usage"
- Rewards not used to reinforced positive behavior



The DoD Enterprise Model

ONCE LINKED

Then have to target the approach, recognizing:

- ***Change cannot happen all at once***
- ***Therefore, start with important, but less threatening, areas***



The DoD Enterprise Model

AND, MORE IMPORTANTLY...

Must positively influence organizational and individual performance by:

- ***Establishing a Performance Management System that links organizational and individual goals and objectives***
- ***Communicating desired outcomes***
- ***Reinforcing "good" organizational & individual behavior***



**IMPROVE INFORMATION
SYSTEM &
INFRASTRUCTURE
SUPPORT**

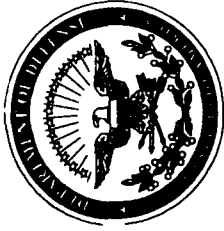

The DoD Enterprise Model

NEAR TERM ASD(C³I) GOALS (Perry Memo, 13 Oct 93)

- ✓ *Eliminate duplicate Legacy Systems as soon as possible (3 Yr. Goal)*
 - ◆ *Establish a Functional Baseline (Process, Data, Applications, and Infrastructure)*
- ✓ *Standardize Data as Soon as Possible*
- ✓ *Continue Business Process Re-Engineering*

Other Infrastructure Goals:

- ✓ *Security*
 - ✓ *Utility*
-



The DoD Enterprise Model

LONG TERM INTEGRATED GOAL

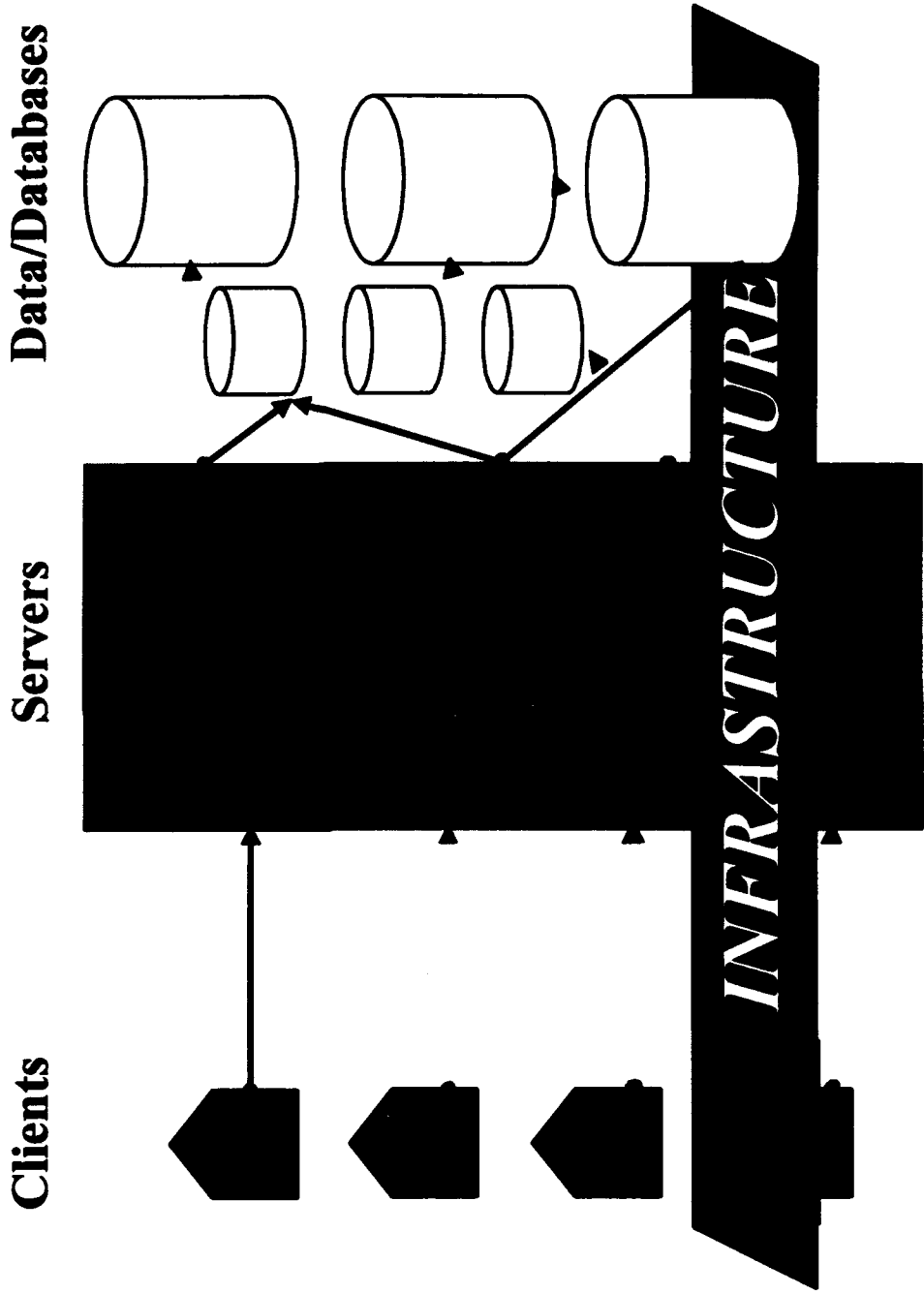



The DoD Enterprise Model

**SHARED, STANDARD, CORPORATE
DATA**

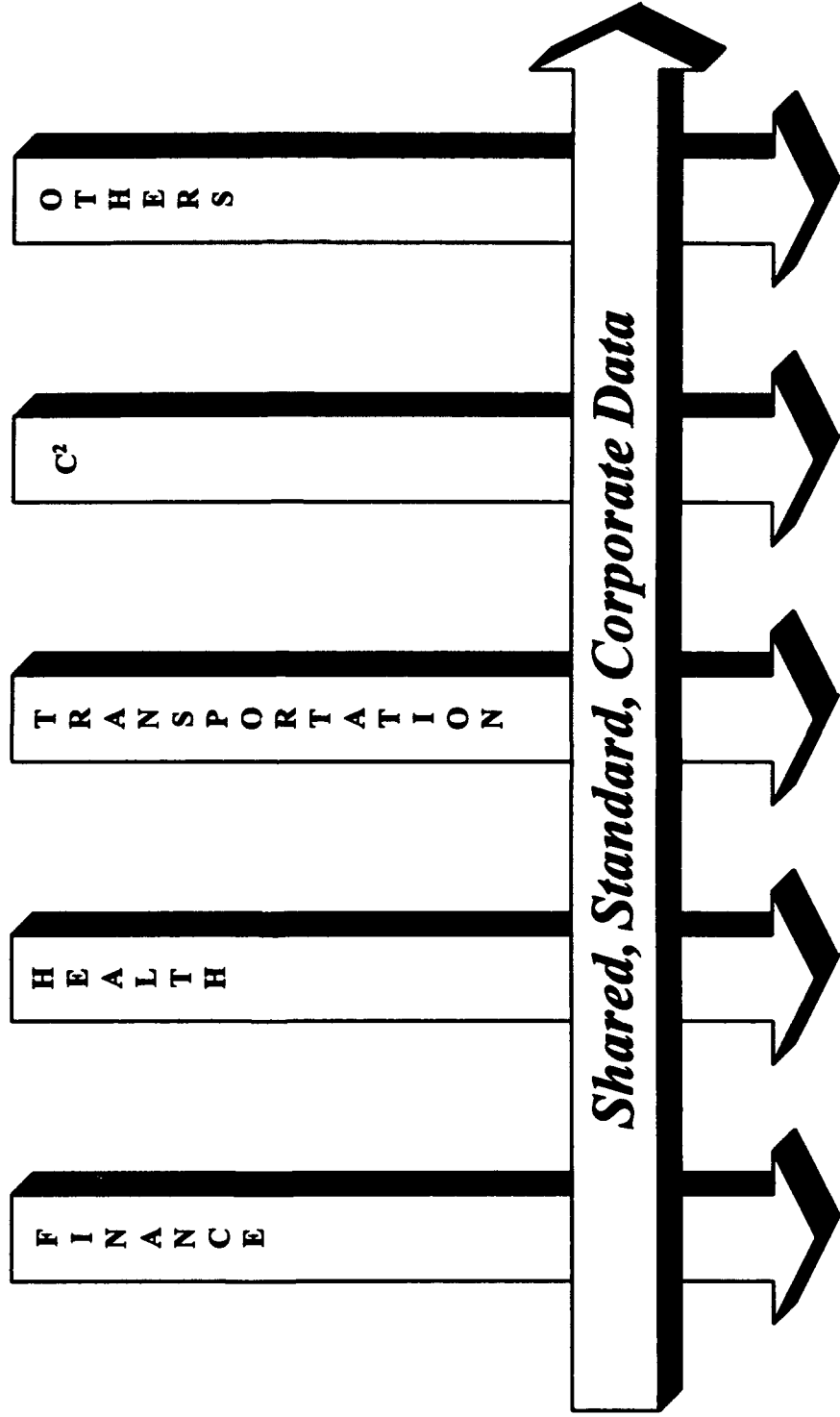



The DoD Enterprise Model

DATA MIGRATION STRATEGY

Legacy Systems
Organizational/Functional
Application Databases

Migration Systems
Functional Application
Databases

Target Systems
Corporate Applications
and Shared Databases

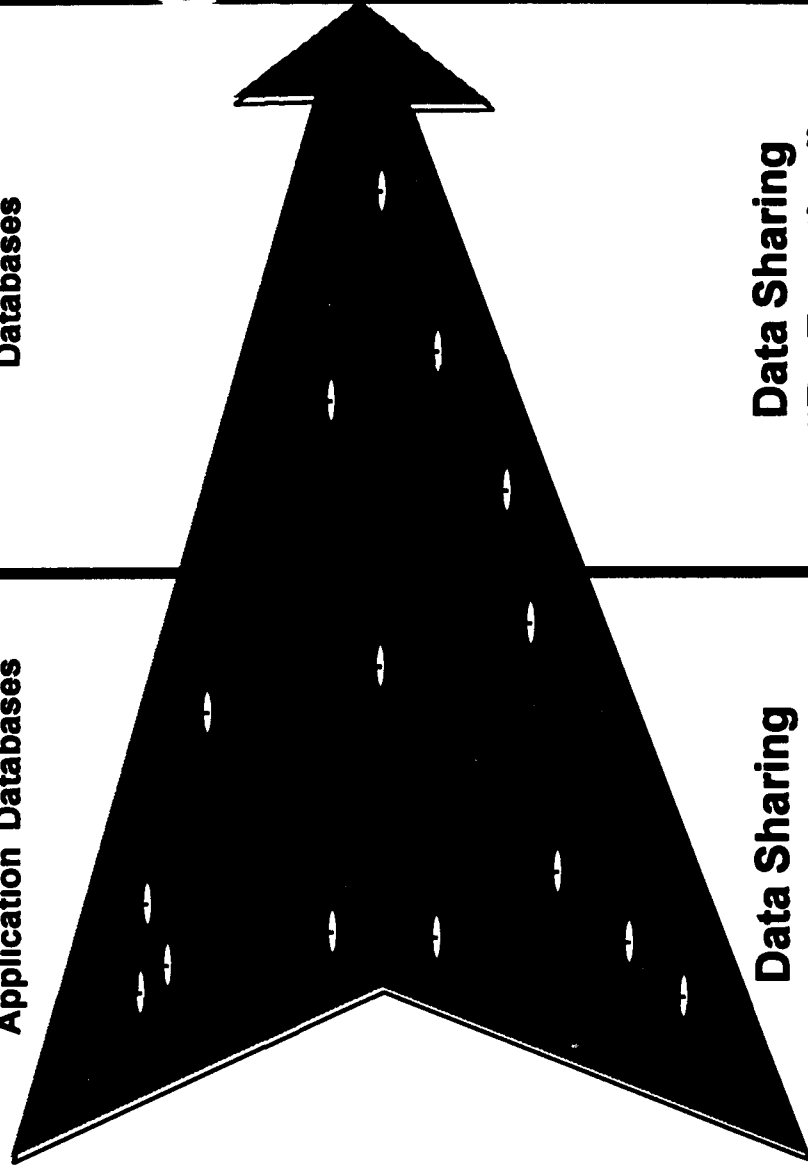

Data Sharing
"After the Fact"

Data Sharing
"By Function"

Data Sharing
"Cross-functional"

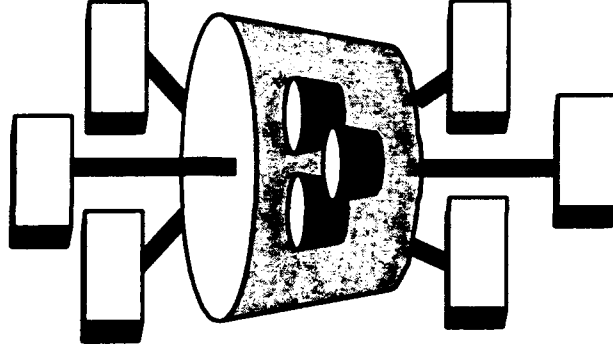



The DoD Enterprise Model

3 TIERED / OPEN DISTRIBUTED ENVIROMENT

How It Can Assist in Accelerating Migration and Simultaneous
Integration

Clients

Management and
Analytical Applications
(DATA USERS)

Data/Legacy Systems

Operational Transaction
Based Applications (Data
Initiators and Users)

Server

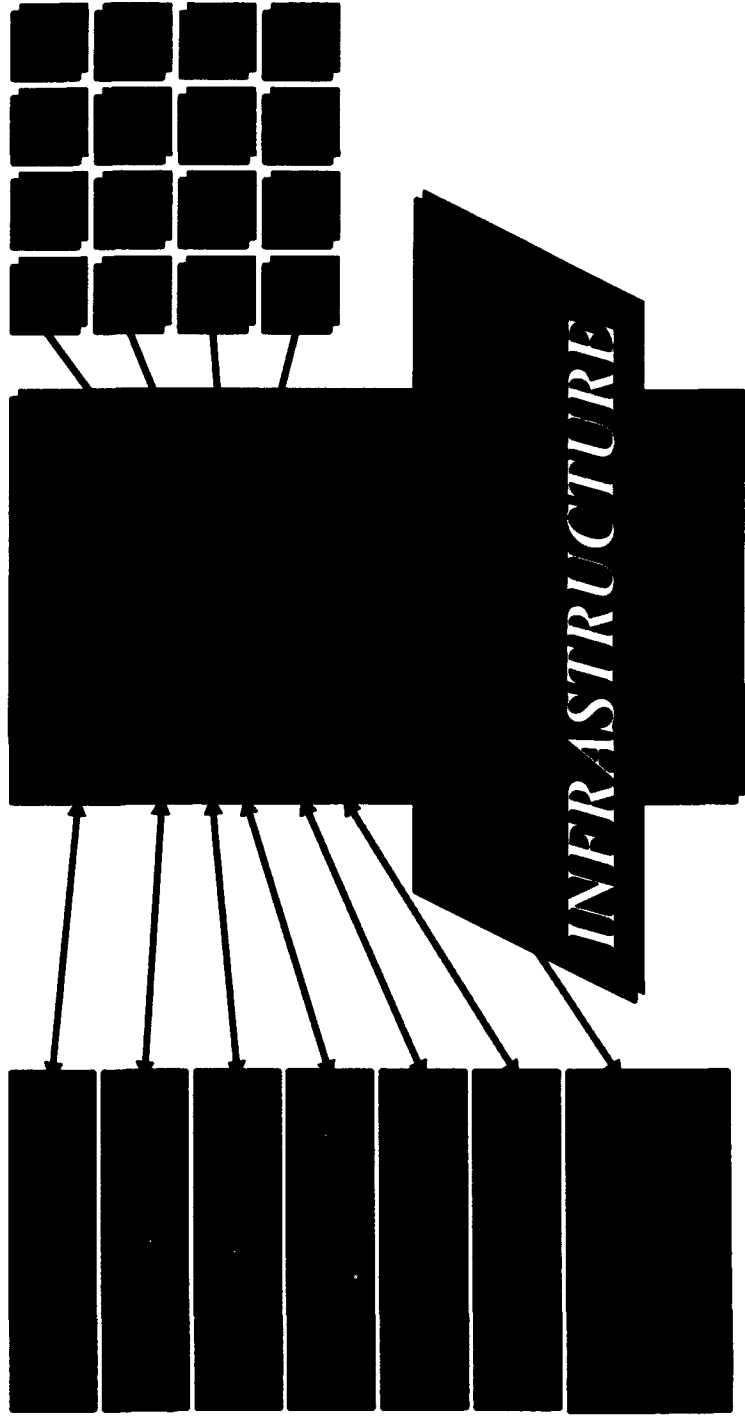



CLOSING COMMENTS



The DoD Enterprise Model

KEY TO SUCCESS

Functional, Data, and Technical Communities must plan and execute a strategy for improving their missions, processes, data functions, organizations, and systems, consistent with the overall DoD goals and objectives, and integrate their efforts with other communities using the Enterprise Model Approach



The DoD Enterprise Model

Let's work together
and continue this
open dialog to
reach our shared
vision.

The Journey to the Future is never finished!