

LOAN DOCUMENT

PHOTOGRAPH THIS SHEET

①

AD-A276 966



DTIC ACCESSION NUMBER

LEVEL

INVENTORY

ASCT-TR-94-5006

DOCUMENT IDENTIFICATION

Aug 93

Approved for public release
Distribution Unlimited

DISTRIBUTION STATEMENT

ACCESSION BY	
NTIS	GR&I
DTIC	TRAC
UNANNOUNCED	
JUSTIFICATION	
BY	
DISTRIBUTION/	
AVAILABILITY CODES	
DISTRIBUTION	AVAILABILITY AND/OR SPECIAL
A-1	

DISTRIBUTION STAMP

DTIC
ELECTR
MAR 10 1994
C D

DATE ACCESSIONED

DATE RETURNED

DATE RETURNED

94-07861



REGISTERED OR CERTIFIED NUMBER

94 3 9 115

DATE RECEIVED IN DTIC

PHOTOGRAPH THIS SHEET AND RETURN TO DTIC-FDAC

H
A
N
D
L
E

W
I
T
H

C
A
R
E

ASCT-TR-94-5006

MODULAR SIMULATOR SYSTEM (MSS)
EXECUTIVE REPORT

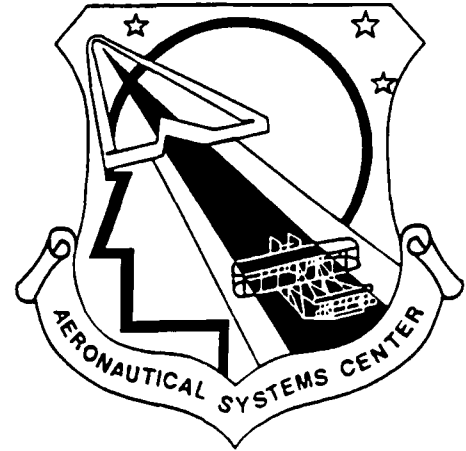

K KELLY, J BROWN,
G KAMSICKAS, W TUCKER

BOEING DEFENSE AND SPACE GROUP
SIMULATION AND TRAINING SYSTEMS
499 BOEING BLVD
HUNTSVILLE, AL 35824

AUGUST 1993

FINAL REPORT

APPROVED FOR PUBLIC RELEASE; DISTRIBUTION IS UNLIMITED.

SYSTEMS ENGINEERING DIVISION
AERONAUTICAL SYSTEMS CENTER
AIR FORCE MATERIEL COMMAND
WRIGHT PATTERSON AFB OH 45433-7126

DHS QUALIFIED SOURCE 1

NOTICE

When Government drawings, specifications, or other data are used for any purpose other than in connection with a definitely Government-related procurement, the United States Government incurs no responsibility or any obligation whatsoever. The fact that the government may have formulated or in any way supplied the said drawings, specifications, or other data, is not to be regarded by implication, or otherwise in any manner construed, as licensing the holder, or any other person or corporation; or as conveying any rights or permission to manufacture, use, or sell any patented invention that may in any way be related thereto.

This report is releasable to the National Technical Information Service (NTIS). At NTIS, it will be available to the general public, including foreign nations.

This technical report has been reviewed and is approved for publication.

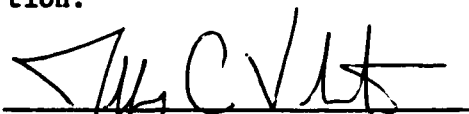

JEFFREY C. VALITON, Maj, USAF
Program Manager
Special Programs Division

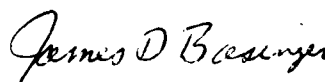

JAMES D. BASINGER
Team Leader
Special Programs Division



JAMES J. O'CONNELL
Chief, Systems Engineering Division
Training Systems Program Office

If your address has changed, if you wish to be removed from our mailing list, or if the addressee is no longer employed by your organization please notify ASC/YTSD, WPAFB, OH 45433-7111 to help us maintain a current mailing list.

Copies of this report should not be returned unless return is required by security considerations, contractual obligations, or notice on a specific document.

REPORT DOCUMENTATION PAGE

Form Approved
OMB No 0704-0188

Public reporting burden for this collection of information is estimated to average 1 hour per response, including the time for reviewing instructions, searching existing data sources, gathering and maintaining the data needed, and completing and reviewing the collection of information. Send comments regarding this burden estimate or any other aspect of this collection of information, including suggestions for reducing this burden, to Washington Headquarters Services, Directorate for Information Operations and Reports, 1215 Jefferson Davis Highway, Suite 1204, Arlington, VA 22202-4302, and to the Office of Management and Budget, Paperwork Reduction Project (0704-0188), Washington, DC 20503.

1. AGENCY USE ONLY (Leave blank)	2. REPORT DATE 20 Aug 93	3. REPORT TYPE AND DATES COVERED FINAL
----------------------------------	-----------------------------	---

4. TITLE AND SUBTITLE Modular Simulator System (MSS) Executive Report	5. FUNDING NUMBERS F33657-86-C-0149 64227F
---	--

6. AUTHOR(S) K. Kelly, J. Brown G. Kamsickas, W. Tucker	
---	--

7. PERFORMING ORGANIZATION NAME(S) AND ADDRESS(ES) Boeing Defense and Space Group Simulation and Training Systems 499 Boeing Blvd Huntsville, AL 35824	8. PERFORMING ORGANIZATION REPORT NUMBER S495-10441-1
--	--

9. SPONSORING/MONITORING AGENCY NAME(S) AND ADDRESS(ES) Aeronautical Systems Center Systems Engineering Division Bldg 11 2240 B St Ste 7 Wright-Patterson AFB, OH 45433-7111	10. SPONSORING/MONITORING AGENCY REPORT NUMBER ASC-TR-94-5006
--	--

11. SUPPLEMENTARY NOTES

12a. DISTRIBUTION / AVAILABILITY STATEMENT Approved for public release; distribution is unlimited.	12b. DISTRIBUTION CODE
--	------------------------

13. ABSTRACT (Maximum 200 words)

This report provides an executive overview and top level presentation materials for the Modular Simulator System (MSS). It provides a brief overview of the MSS project, system architecture and design, and application alternatives for employing the design to a simulation and/or training device. This report serves as both an educational and decision tool for all levels of management and engineering personnel. This report describes the basic concept of the MSS design and its basis for development. The intent is to support informed decisions regarding the application of the MSS approach to a specific training system development. Additional sources for detailed MSS data are also provided for further reference.

14. SUBJECT TERMS Modular Simulator System (MSS)	15. NUMBER OF PAGES 71
	16. PRICE CODE

17. SECURITY CLASSIFICATION OF REPORT UNCLASSIFIED	18. SECURITY CLASSIFICATION OF THIS PAGE UNCLASSIFIED	19. SECURITY CLASSIFICATION OF ABSTRACT UNCLASSIFIED	20. LIMITATION OF ABSTRACT UL
---	--	---	----------------------------------

THIS PAGE INTENTIONALLY LEFT BLANK

Abstract

This report provides an executive overview and top level presentation materials for the Modular Simulator System (MSS) also known as 'Mod Sim'. It provides a brief overview of the MSS project, system architecture and design, and application alternatives for employing the design to a simulation and/or training device. This report serves as both an educational and decision tool for all levels of management and engineering personnel. This report describes the basic concepts of the MSS design and its basis for development. The intent is to support informed decisions regarding the application of the MSS approach to a specific training system development. Additional sources for detailed MSS data are also provided for further reference.

Table of Contents

Section	Page
1. INTRODUCTION.	5
1.1 Purpose.	5
1.2 Scope.	5
1.3 How to Use This Report.	
2. REFERENCE DOCUMENTS.	6
3. MODULAR SIMULATOR EXECUTIVE OVERVIEW.	7

Appendices

Appendix A	Modular Simulator System Presentation	9
------------	---------------------------------------	---

1. INTRODUCTION.

1.1 Purpose. This report provides presentation materials, summary data and reference information for the Modular Simulator System (MSS). It describes the basic concepts of the MSS design and its basis for development. The presentation materials provide a top level overview of the MSS architecture and design concepts.

1.2 Scope. This executive report is applicable to a MSS design based program. It provides an overview of the MSS project, design concepts, and approach to employing those concepts to a simulation and/or training device development. This guide is specifically targeted toward upper level management, engineering management, and the project manager. It will help these managers quickly achieve a basic understanding of the MSS.

1.3 How to Use This Report. This report is intended to be used for several purposes. It is primarily informative to a general audience that is not familiar with the MSS concepts. Section 2 provides additional reference materials which define the MSS architecture and design in detail. These materials are essential to achieving a comprehensive understanding of the MSS concepts and applying the concepts to a development effort. Section 3 provides an executive overview of the MSS and is intended to be used as a "white paper". It provides a very brief overview of the MSS and its development basis.

The majority of this report is comprised of a MSS summary presentation provided in appendix A. The presentation is intended for several audiences including upper management, program management and engineering management. Each chart in the presentation has an accompanying page that contains a textual script. The intended audience for each chart is identified in the lower right corner of the script page. Charts identified as "Technical" are intended for presentations to a technical or engineering management audience. Charts identified as "Management" should be used in every presentation including those for executive, management and engineering audiences. The presentation charts and associated script pages provide a complete presentation. This presentation can be given in 45 to 60 minutes.

2. REFERENCE DOCUMENTS.

The following documents are provided for further reference and would be useful in the management and design efforts of a modular simulator design program. The management and engineering design guides provide planning and guidance information for application of the Mod Sim approach and design. The interim and final reports provide detailed analysis results and rationale from the development and demonstration of the MSS design and approach. The generic System/Segment Specifications, Interface Requirements Specification and Interface Design Document provide detailed requirements, design and interface information which can be tailored to a specific application of the MSS approach. The F-16C specifications were those used during the demonstration project and serve as an early example of application tailoring.

- a. System/Segment Specification for the Generic Modular Simulator System, Volumes I-XIII, S495-10400.
- b. System/Segment Specification for the F-16C Modular Simulator System Demonstrator, Volumes I-XII, S495-10415.
- c. Interim Report on Research and Development for Modular Simulator System Phase III Program, Part 1, D495-10402-1, 15 September 1988.
- d. Modular Simulator Design Program, Phase III, Part 2 Final Report, D495-10437-1, 29 August 1991, Revision B.
- e. Follow-on Effort Final Report for the Modular Simulator Design Program, D495-10438-1, 28 August 1991.
- f. Modular Simulator Engineering Design Guide, D495-10440-1.
- g. Interface Requirements Specification for the Generic Modular Simulator System, S495-10734.
- h. Interface Design Document for the Generic Modular Simulator System, D495-10735-1.
- i. Modular Simulator Management Guide, D495-10439-1

3. MODULAR SIMULATOR EXECUTIVE OVERVIEW.

The Modular Simulator System (MSS) Design program, also recognized as 'Mod Sim', is a tri-service supported development program. The program goals include shorter simulator development schedules, reduced simulator development costs and improved simulator supportability. A generic Weapon System Trainer (WST) was partitioned into a discrete set of modules or segments. Generic specifications define/standardize each segment's functions, intersegment communication methods, and the system architecture.

The MSS architecture consists of twelve distinct segments that communicate via a Virtual Network (VNET). The MSS VNET communication architecture is a conceptual mechanism for communication between segments using a message passing protocol and is independent of a specific hardware implementation. This allows the architecture to be adaptable to both high end and low end applications, while accommodating advances in computer technology.

The MSS concept,

- Expands the opportunity for competition by promoting the participation of specialized and smaller companies in simulator development.
- Facilitates reduced cost and low risk system upgrades.
- Is supported by the Air Force, Army and Navy.
- Increases hardware and software reusability.
- Is standardized by generic specifications with tailoring instructions that allow adaptation to specific applications.
- Reduces training system development time through,
 - Parallel design, development, and testing techniques.
 - Faster, more complete systems engineering.
 - Faster system integration.
- Provides a standardized, reusable communication architecture and system interfaces using the Ada software language to enforce interface integrity, a key to successful integration.
- Can be applied to any type of training device, including air and ground vehicle simulators and maintenance trainers.
- Has been demonstrated and validated to the armed services.

The MSS development was accomplished using a three phase process. Phase I was a Request For Information (RFI) to the simulation industry. The purpose of this RFI was to survey the simulation industry to assess industry support and the general feasibility of the MSS concept. The results of this survey were very positive. This led to the Phase II, Modular Simulator Design Concept Development. This competitive

procurement was awarded to two companies, Boeing and Logicon. The products of Phase II were a conceptual MSS architecture that focused on aircrew simulator functional analysis and intermodule communication architecture/design. Each contractor developed a conceptual modular simulator design for this effort. Each contractor's conceptual design formed the basis of their proposal for the Phase III contract. Boeing was awarded the Phase III contract, which consisted of design, demonstration and validation of the MSS.

Phase III was divided into two parts. Part 1 concentrated on the specification and design of the MSS architecture. During Part 1, the system was partitioned into segments that had generic intersegment interfaces, were loosely coupled, and focused on a specific area of simulation expertise. An intersegment communication architecture was developed that was non-proprietary, supported industry standards, exhibited low data latency, provided 50% growth and was available for use in the concept demonstration. Performance models of various system architecture design alternatives were used to predict feasibility and system performance. A thirteen volume generic System/Segment Specification was developed to formally document the requirements for a MSS implementation. During Part 2 of Phase III, the MSS design developed in Part 1 was implemented and tested using a government provided F-16 crew station and existing F-16 simulator source code. Phase III resulted in a successful demonstration of the MSS concepts.

To foster industry participation and support for the MSS design, Boeing subcontracted the design and development of 75 percent of the segments. The Phase III subcontractors were Rediffusion Simulation Limited (RSL), Science Applications International Corporation (SAIC), AAI, and Intermetrics. Further industry participation was solicited through regular Interface Standards Working Group (ISWG) meetings. At these meetings both industry and government simulation experts participated in the review of the MSS design and subsequent demonstration.

Following Phase III, an interface was defined and added to the MSS architecture to support multiple simulator/team training (e.g.; Distributed Interactive Simulation). Tailoring instructions were added to the generic specifications to ease adaptation to specific applications. Additional documentation, including an engineering design guide, management guide and executive report provide overviews of the MSS approach targeted to specific audiences.

The MSS is a demonstrated, viable simulator architecture and development approach that can shorten development schedules, reduce costs and improve supportability of many simulator and training device applications.

Appendix A

Modular Simulator System Presentation

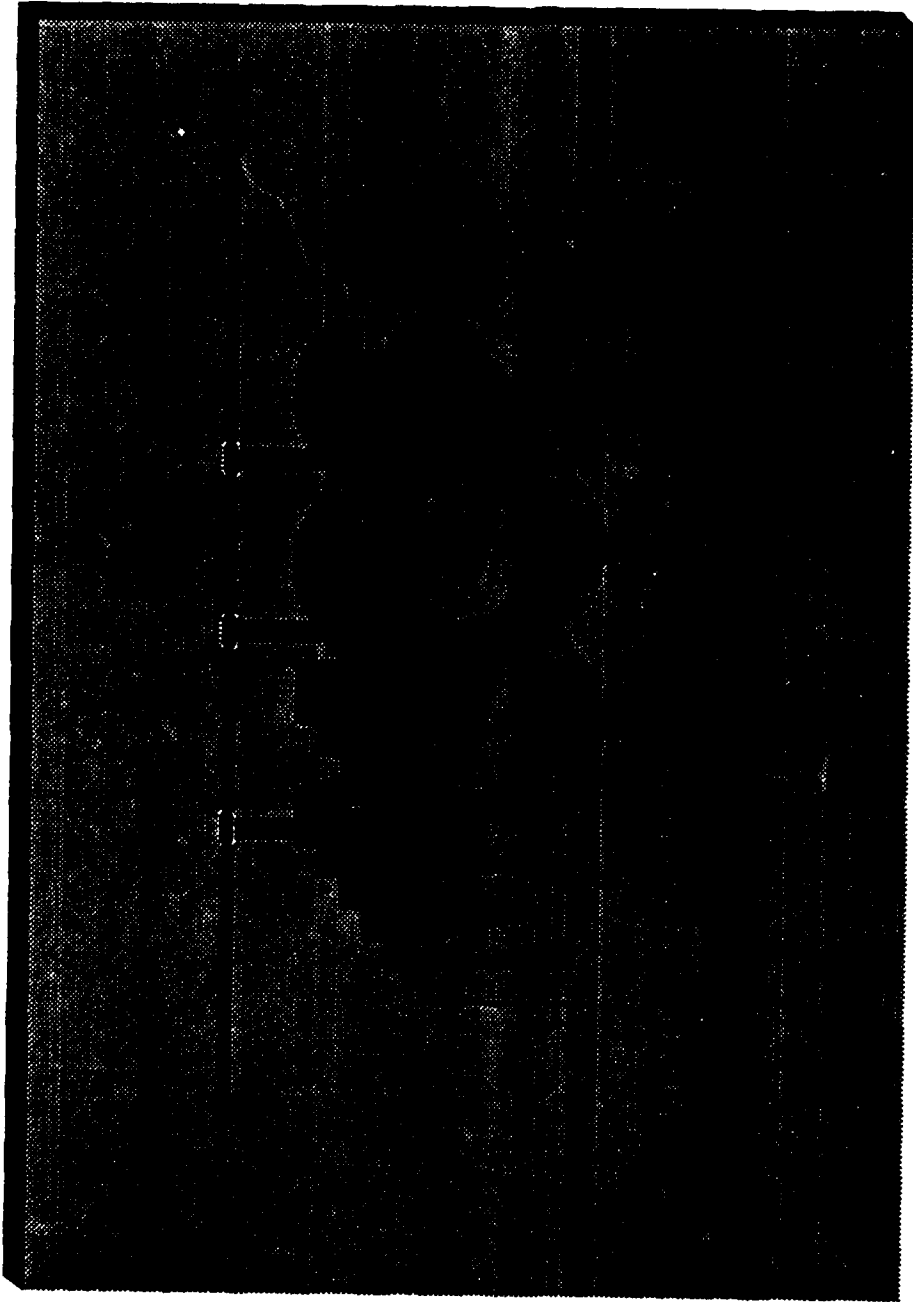

D495-10441-1

Modular Simulator System

- This briefing summarizes and culminates an effort to develop, demonstrate and standardize a cost effective design for future aircrew training devices. The briefing begins with an overview of the project's fundamental goal, history, resultant architecture and most important products.
- The overview is followed by a discription of the Mod Sim design and potential applications of the concept.



Modular Simulator System



Project Overview

Modular Simulator System Design

Modular Simulator System Applications

Goal

- The Mod Sim project's goal was to reduce simulator development schedules and costs. Three objectives were identified to support this goal. They were:
 - Expand competitive base by opening the market to companies who may specialize in discrete simulation areas, such as radar, electronic warfare, physical cues, etc. It affords an opportunity for smaller companies, with their typically lower costs, to bid on one or more of the segments.
 - Promote systematic reuse of software & hardware, resulting in reduced cost and schedule. This is true within a project across a family of trainers, and even across simulator projects.
 - Develop a process that leverages this competitive base and reuse to develop new simulators quickly and inexpensively. The generic Mod Sim specifications and associated guides form the basis of this approach. A vast majority of the systems engineering activity is already accomplished. The functional allocation of each segment is done and the inter segment interfaces are generically defined to allow rapid tailoring for a particular application.
 - The approach was to define a modular, reusable simulator architecture that could be developed quickly and inexpensively. The primary focus of this approach was the development and standardization of a communication interface. The interface provides the coordination between the loosely coupled segments, while standardization eliminates the need for proprietary interfaces and their associated costs.



Project Overview

Purpose

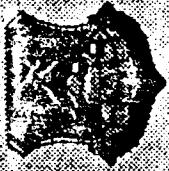

GOAL

Reduce simulator development schedules and acquisition costs

OBJECTIVES

- Expansion of competition base for simulator development
- Systematic reuse of software, hardware, design and data
- Define and improve process to build simulators

APPROACH

Standardize a communication interface for Modular Flight Simulators

Participation

➤ The Mod Sim program is a contracted development program sponsored by the tri-services with Boeing as the prime contractor and a team of subcontractors including AAI, Rediffusion Simulation Limited (RSL), Science Applications Int. Corp. (SAIC) and Intermetrics. In addition, the remainder of the simulation industry was invited to participate through membership on the Interface Standards Working Group (ISWG), to provide technical support, monitor and evaluate the effort.



Project Overview Participation

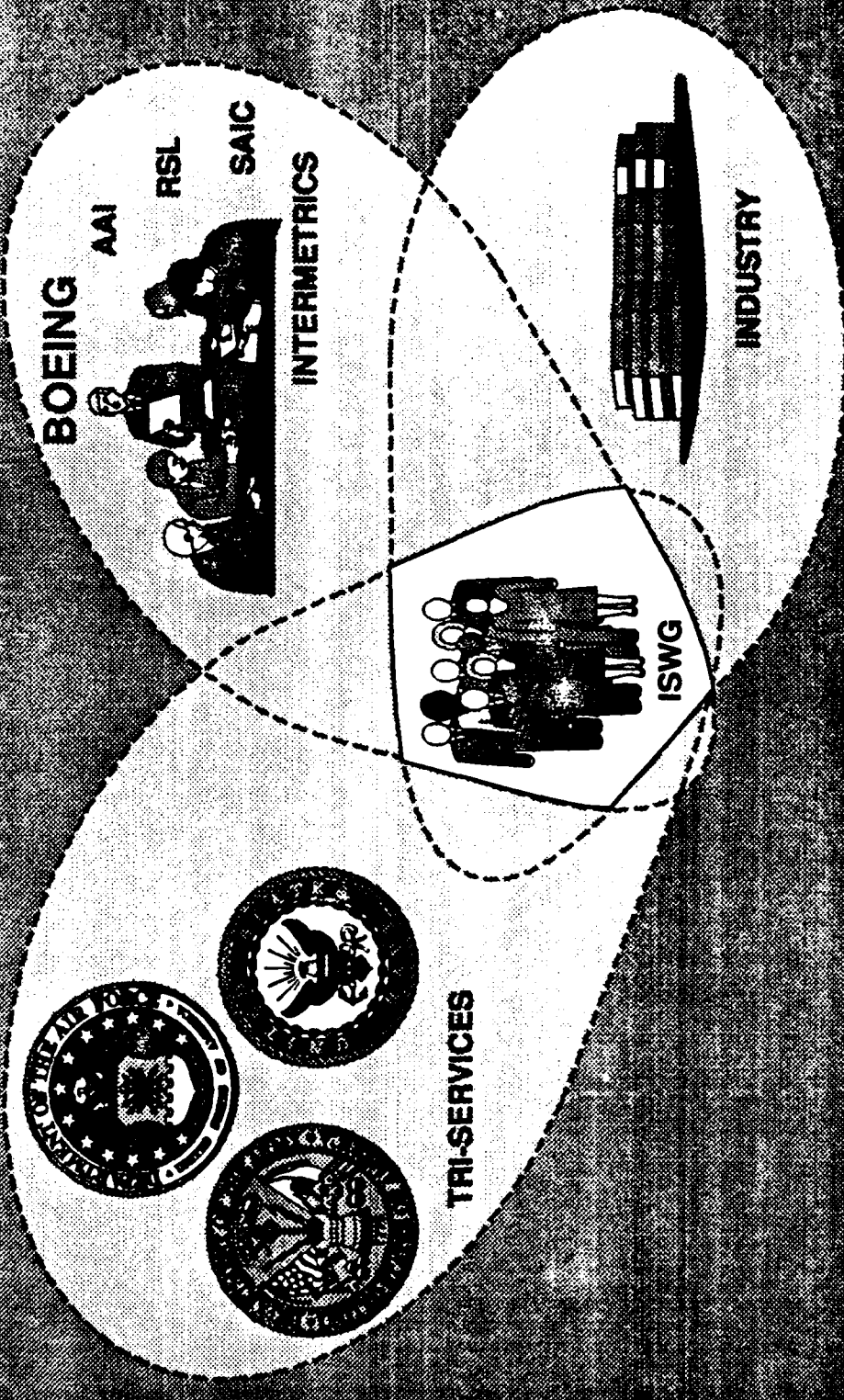
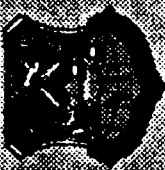

HISTORY

- The Mod Sim program began with a request for information phase. During this phase, industry conducted feasibility studies with respect to a modular simulator concept. This resulted in a general acceptance of the concept and formed the basis for the development study phase of the program.
- Boeing and Logicon were selected as competitors for the development study phase. They developed their approach and conceptual designs and performed design trade studies which resulted in proposed baseline architecture proposals.
- Boeing was selected to demonstrate and validate the concept in Phase III. This phase consisted of two parts. In Part 1, generic simulation functions were partitioned into stand-alone segments. A system performance model was developed to evaluate and select a communication architecture. The resulting functional allocation and architecture were documented in a generic system specification, which was subsequently tailored for the F-16C demonstration device. Part 1 culminated with an interim report. In Part 2, an F-16C demonstrator was developed and tested providing the proof of concept. The generic specifications developed in Part 1 were revised to incorporate the lessons learned and a final report submitted to complete the phase.
- After completion of Phase III, several follow-on options were exercised. An interoperability interface design was developed to permit Mod Sim operation on a multiparticipant network such as the Distributed Interactive Simulation (DIS). The generic specifications were revised to reflect the new environment segment resulting from this effort and tailoring instructions were added to the specifications. Additionally, an engineering design guide and a management guide were

developed to assist in the development of future Mod Sims.

- Over the course of the project, a wide range of flight simulators and aircraft were functionally decomposed by the team and the resulting functions were allocated to 12 modules. This allocation was presented and discussed at length in the ISWG. Specifications were then developed for each module.
- Subsequent to the functional allocation, the module communication interfaces were defined, specified and reviewed by the ISWG.
- The project was able to demonstrate and validate to the simulation community that the modular design, communication architecture, and stand-alone module testing resulted in a reduction of integration time and the feasibility of parallel and independent module development.
- Industry and the government were able to review the progress and findings of the project based on several documents. These project outputs included interim and final reports that discussed the results of development, testing and lessons learned. Several guidance documents were developed to assist managers, designers, and developers of future modular simulator programs. These guides included an engineering design guide, a management guide, an IRS and an IDD.

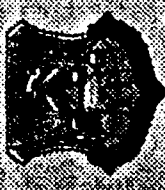

Project Overview History

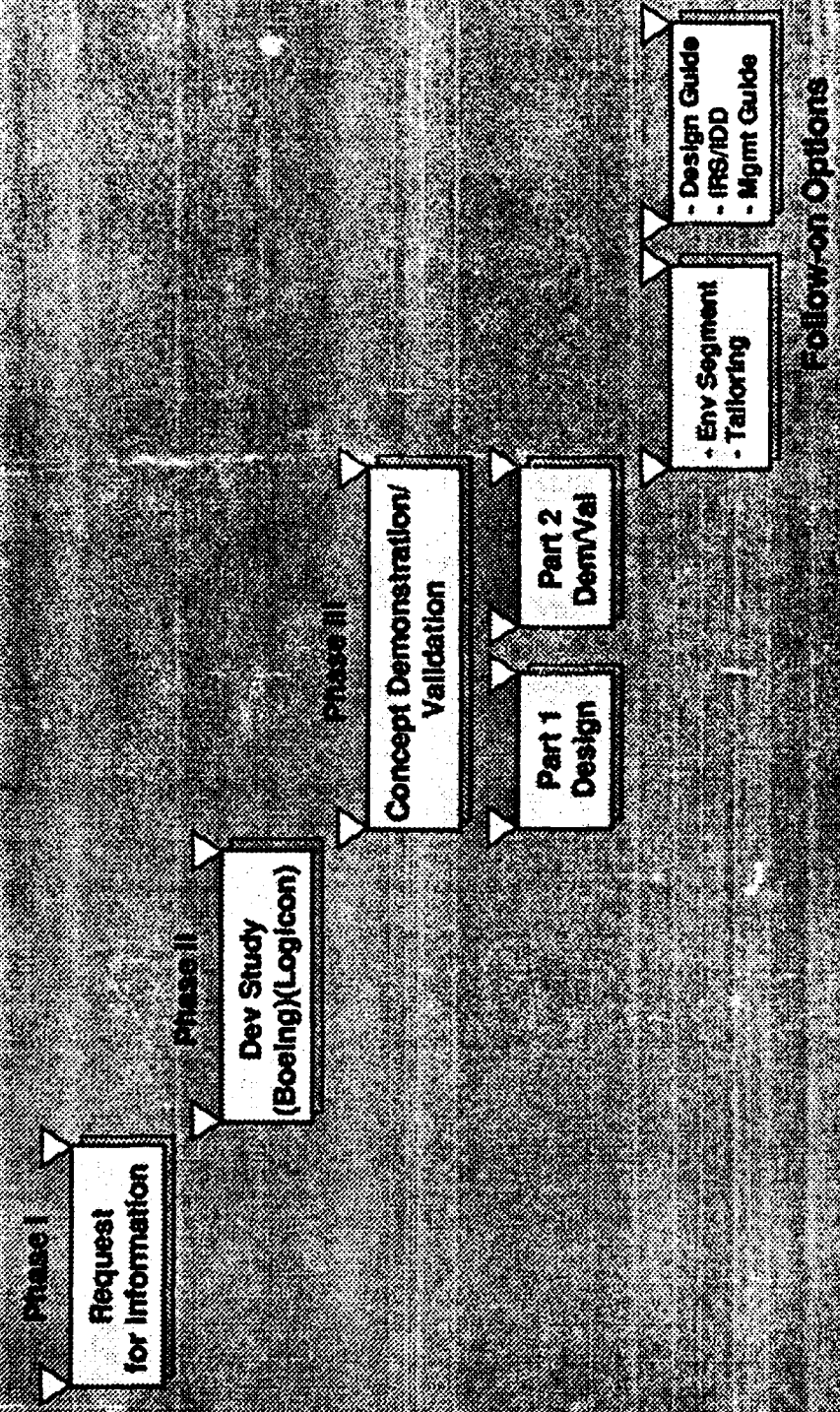
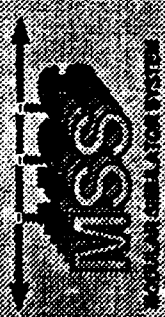

ARCHITECTURE

➤ The Mod Sim program partitioning resulted in 12 segments (formerly modules). The twelfth segment and the use of the word module resulted from studies conducted after the demonstration. The twelfth segment houses the environment. This improves the reuse potential of the environment software and more readily accommodates multiple simulator environments such as DIS. The word "module" was reserved for hardware systems and it was recognized that Mod Sim segments were only loosely coupled to the hardware. Hence, a module consists of one or more segments, while a segment is equivalent to an original module.

➤ Briefly:

- The Flight Station includes the physical crew position(s), physical representation and instrumentation along with simulation of standard aircraft systems such as electrical power, hydraulics, etc.
- The Flight Controls includes the simulation of the controls such as the stick or yoke, flap control, landing gear lever, etc. and the associated control surfaces.
- The Flight Dynamics includes the simulation of the aerodynamics including equations of motion and generation of the aircraft state vector.
- The Radar includes the simulation of the aircraft radar system processing and radar image generation.
- The Weapons includes the simulation of the aircraft weapon systems and weapons.
- The Environment provides simulation of the natural environment, an interface to a SIMNET or DIS type of tactical network environment in a multiple simulator mode and simulates the tactical and natural environment in the autonomous or stand-alone mode.

- The Electronic Warfare includes the simulation of the aircraft ECM and ECCM systems including expendables.
- The Nav/Comm includes the simulation of the aircraft navigation and communication systems such as inertial navigation, intercom, IFF, ILS, etc.
- The Propulsion includes the simulation of the engines and thrust generation capabilities of the aircraft.
- The Physical Cues includes the simulation of the motion and environmental sound cueing.
- The Visual includes the generation and display of out the window images, infrared imagery, electro-optical imagery, etc.
- The IOS provides the interface between the instructor or operator and the simulation. It includes the central control of the simulator.
- The central feature of the Mod Sim architecture is the virtual network. The virtual network is a mechanism for communication between segments using a message passing protocol. Each of the segments is connected to a virtual network by a network interface unit. The interface units send and receive messages providing the communication and coordination between segments required to execute the simulation. The Mod Sim virtual network has been carefully defined to be independent of specific hardware implementation. This provides two benefits:
 - Ability to scale the concept to both high end and low end applications
 - Concept is adaptable to advances in computer technology



MSS Design Architecture

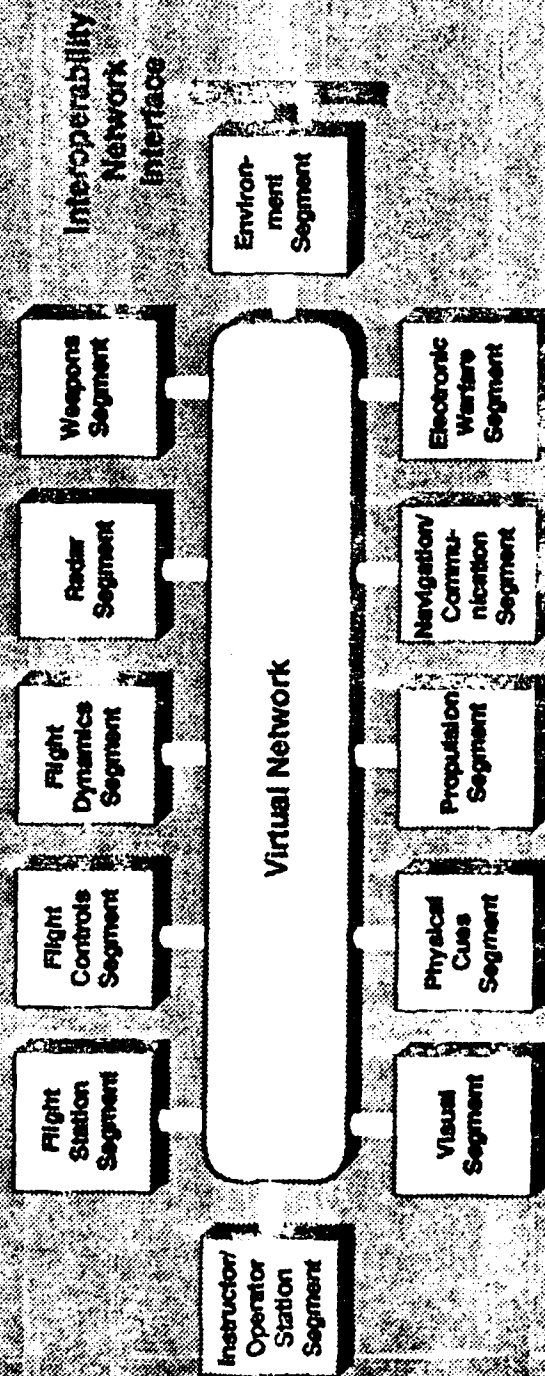

DOCUMENTATION

- The Mod Sim program included development and delivery of several important documents. The generic system/segment specification was developed during Part 1 of the dem/val phase and has been updated on several occasions to incorporate new information. This specification provided the framework for the F-16C demonstrator specification, which is identical in format and merely tailored to reflect the application requirements. Additionally, an IRS and an IDD were developed. The IRS and IDD were developed from the interface information in the specification appendices.
- In addition to the specifications developed in Phase III, Part 1, an interim report was published, documenting the various trade studies performed and the resultant findings. At the completion of Phase III, a final report was published which included the test results from the demonstration and the lessons learned from the program. Because of the subsequent interoperability trade study, another final report was published which was primarily limited to the results of the study.
- In an effort to make the generic specifications more useful, two guidebooks were developed. The two guidebooks consist of an engineering design guide and a management guide. The engineering design guide is targeted to systems and design engineers. It addresses the unique characteristics of a Mod Sim including design studies and decisions required to develop a Mod Sim simulator. The management guide is targeted to managers and deals with the programmatic concerns of a Mod Sim development, including cost, schedule, testing and integration.



Project Overview Documentation



Specifications

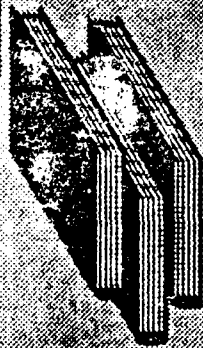

- > Generic System Segment Specification S495-10400
- > F-16C Demonstrator System Segment Specification S495-10415
- > Interface Requirements Specification S495-10734-1
- > Interface Design Document S495-10735-1

Reports

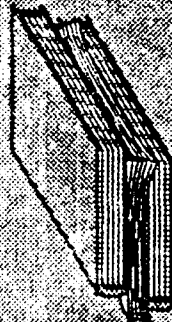

- > Phase III, Part 1 Interim Report D495-10402-1
- > Phase III, Part 2 Final Report D495-10437-1A
- > Follow-on Final Report D495-10438-1

Guides

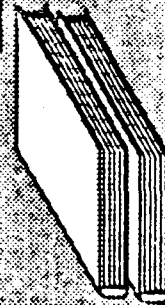

- > Engineering Design Guide D495-10440-1
- > Management Guide D495-10439-1

MSS DESIGN INTRO

- This portion of the briefing addresses the key elements of the Mod Sim design including generic specifications, architecture, interfaces, functional allocation, integration, test and lessons learned.



Modular Simulator System



Project Overview

Modular Simulator System Design

Modular Simulator System Applications

SPECIFICATIONS

- One of the more significant products of the project is the generic Mod Sim specification. It is a system/segment specification, developed in accordance with MIL-STD-490A, DOD-STD-2167A and DI-CMAN-80008A, and consists of 13 volumes. This specification provides the foundation for the MSS. The first volume contains the system level requirements of the simulator while the remaining volumes provide the segment specific requirements for each of the segments. All of the volumes contain tailoring instructions for adapting the generic specification to specific applications.
- The multi-volume approach supports subcontracting by providing a separate specification for each segment as a product.



MSS Design Specifications



System/Segment Specification for the Generic Modular Simulator System

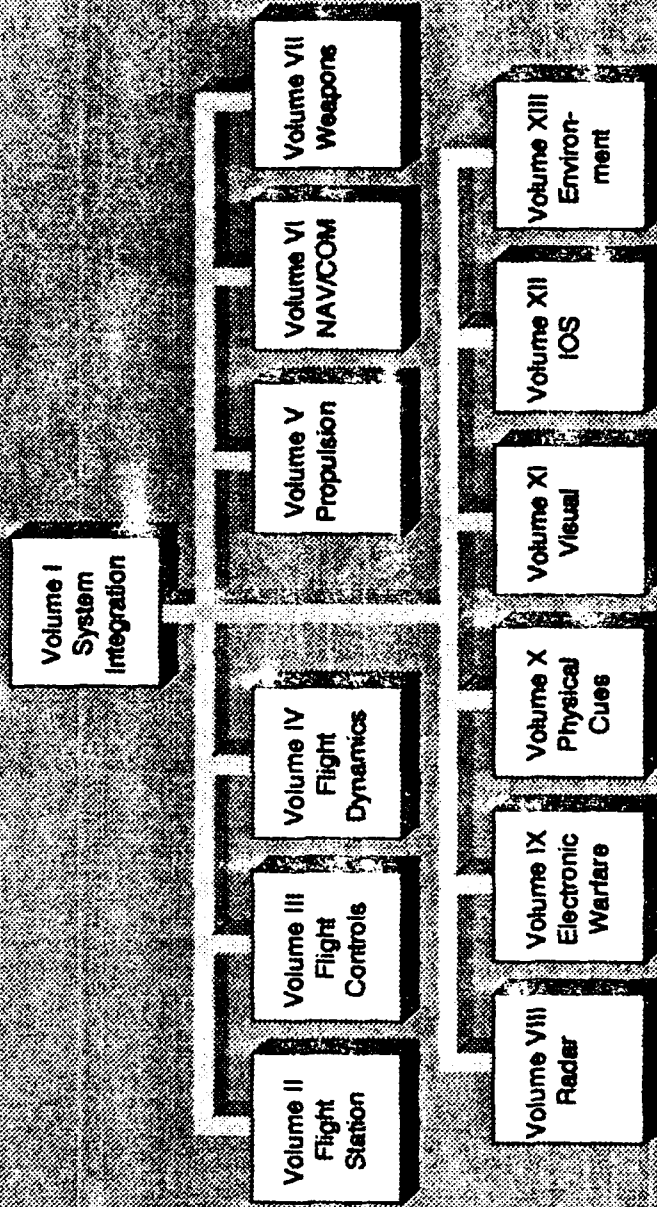

Complies with MIL-STD-490A, "Specification Practices"
Data item description D1-CMAN-9000EA, "System/Segment Specification"

TAILORING

- At the request of industry, tailoring instructions were added to the generic specification for adapting requirements to individual applications. The approach for a Mod Sim development is to tailor the generic specification with respect to customer/application requirements and constraints, perform trade studies, allocate segments to modules and generate the application specific specifications.
- The demonstrator program clearly illustrated that a generic specification could be tailored to specify and develop an application simulator.

MSS Design Tailoring



Generic Specifications
with Tailoring Instructions

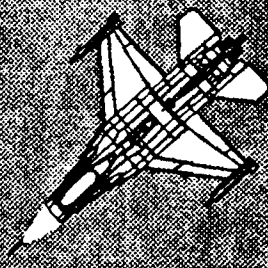
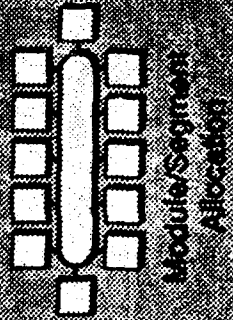

Application
Specific
Requirements

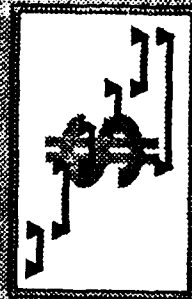
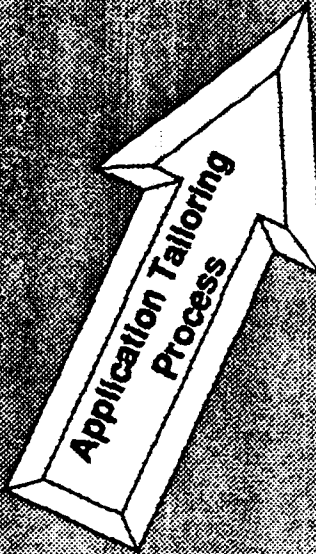

Affordability and
Schedule
Constraints



Trade
Studies

Application
Specifications

ADVANTAGES

- The tailoring approach allows a developer to take advantage of the up front systems engineering already accomplished during the development program. Since a tailoring process is available, requirements and interface specifications are defined much more rapidly.
- The Mod Sim specifications provide clearly defined boundaries for developing teaming arrangements. In order to subcontract an individual segment, the prime contractor or system integrator need only provide the resulting system level requirements of Volume 1, the segment requirements of the applicable segment volume, and a tailored interface specification.
- On future programs costs should be reduced, schedules should be compressed and risk abated through the ability to reuse these Mod Sim program engineering products.



MSS Design Advantages



Majority of up-front systems engineering is completed

- Specifications developed
- Segment interfaces developed

Tailoring process identified

Format promotes teaming and subcontracting arrangements

Cost, schedule and risk reduction

COMPATIBILITY WITH OTHER ACTIVITIES

- The Mod Sim has been developed and updated to be compatible with other activities and initiatives in the simulation industry. The advent of the Universal Threat System for Simulators (UTSS), SIMNET and then DIS standards prompted the creation of the Environment segment within the MSS. Projects like Software Technology for Adaptable, Reliable Systems (STARS), J-MASS and F-22 have proposed/used the work from Mod Sim.
- Other activities like the SEI's structural model, the Software Productivity Consortium (SPC) Synthesis process, SDIP, Project 2851 and efforts to develop generic Instructor/Operator Stations have also been considered for use in the MSS design.

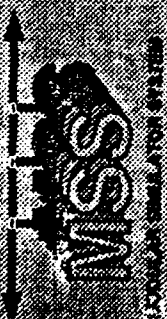

MSS Design Compatibility

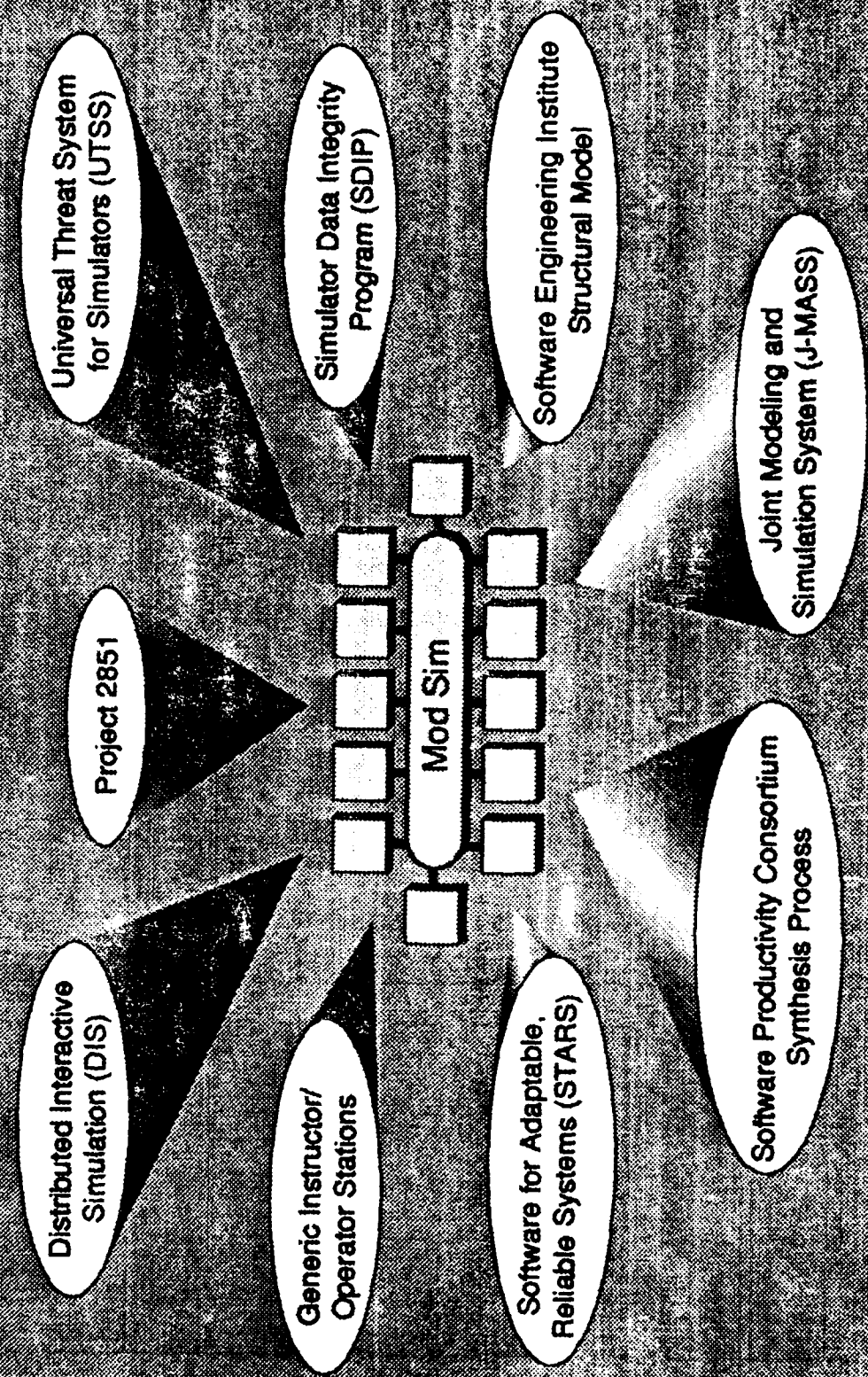

COMMUNICATION ARCHITECTURE

- Development of the communication architecture was based on a rigid set of requirements. The architecture must not be proprietary, it must be supported by a standard, it must be readily available, it must be fast, and it must be expandable.
- In order to evaluate the candidate architectures, a system performance model was developed. Seven protocols and 14 data buses were evaluated using the model.

	Protocols	Buses
ISO/OSI	GAMT-103	VME DMA
SAE MRT	TCP/IP	Smart Net
TP 4	VMTP	STARNET
XTP		PRONET 80
		HSRB
		MAP
		PRONET 10
		Vetical VME
		ETHERNET 10
		CSMA/CD 100
		HSLB

- The result of this trade study yielded FDDI as the media and XTP as the protocol. Further study led to the concept of a Virtual Network (VNET) in order to give the implementer more flexibility in choosing a design. It is recommended that FDDI and XTP be used, but this is not a hard and fast requirement.



MSS Design Communication Architecture



Requirements

- > Non-Proprietary design
- > Standard
- > Available - COTS preferred
- > Performance - speed
- > Growth - 50% goal

Accomplishments

- > Developed system performance model
- > Analyzed 7 different protocols
- > Analyzed 14 different data buses

Result

- > Suggested Media: Fiber Distributed Data Interface (FDDI)
- > Suggested Protocol: Xpress Transfer Protocol (XTP)
- > Implementation: Virtual Network

COMMUNICATION ARCHITECTURE 2

- As the Mod Sim program evolved, it became apparent that a more flexible communication architecture would be required. Consequently, the concept of a virtual network emerged. The virtual network is a message based communication concept, which may be implemented on any communication media. A virtual network is achieved if the segments are unaware of the media or architecture implementation.
- The primary reason for an alternative was that strict adherence to the suggested FDDI/XTP architecture could drive unnecessary cost requirements onto low end or part task devices. While FDDI has been proven to provide the performance necessary for moderate to large systems, it does entail a minimum cost which could be objectionable to some less complex applications where data transfer speed is less of a concern.
- The virtual network provides a developer the flexibility to select the best hardware and software solution for the application, while preserving the Mod Sim principles and goals.
- The required characteristics of the virtual network are message based communication, use of the Mod sim segment application interfaces and the ability to expand as required.



MSS Design Communication Architecture

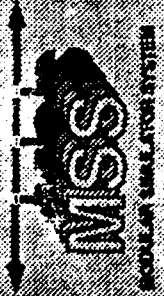

Optional Communication Architecture - Virtual Network

Why?

- > Reduce cost of FDDI/ATP hardware in low cost or low fidelity trainer applications
- > Allow flexibility to obtain "best" cost and technical performance while maintaining Mod Sim goals

Requirements

- > Message based data transfer methodology
- > Standard segment application interfaces (tailorable)
- > Support growth requirements

APPLICATION INTERFACES

- The Application Interfaces are the basis for communication of data in a Modular Simulator System. They are written in Ada, which promotes better understanding because of the ability to express variables and groups of variables in English-like format. Another advantage to specifying the interfaces in Ada is the inherent configuration management that comes from being able to process the specification with a software compiler. The interfaces are documented in an Interface Design Document. Understandability not only enhances maintainability, it also reduces the risk of interface mismatches at integration time.
- The baseline interfaces are generic and can be reused through application specific tailoring. Maintaining the interfaces in Ada also provides portability through hardware and software independence.
- In the past, the classic interface scheme has been shared memory datapool. The MSS makes use of a message based rather than a memory based data passing scheme. This type of communication between segments enforces data hiding and a loose coupling of the segments. In the example, an interface change to Message B requires recompilation of only Segments 2 and 3. Whereas a change to Message A would require recompilation of Segments 1, 2 and 3 only, leaving the remaining segments unaffected.
- Although the benefit of grouping the interfaces according to real world objects was not a goal or a requirement of the Mod Sim program, the resultant interface groupings are primarily object-oriented, which enhances understandability and maintainability.



MSS Design Application Interfaces

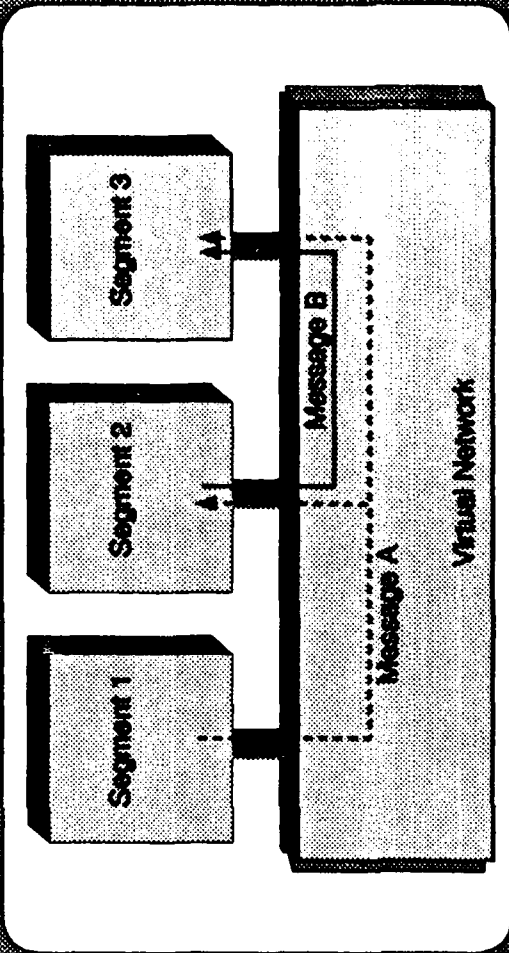

Written in Ada

- > Easy to understand
- > Reusable/Generic
- > Portable

Interface changes impact only the segments that use the interface

Follows object-oriented software design principles

REUSE/TAILORING CONCEPT

- Defining the Application Interfaces involves tailoring the generic Interface Requirements Specification and Interface Design Document to the specific requirements of the application system. The interfaces are grouped in Ada packages which allows processing by an Ada compiler. The ability to use a compiler on the interface definition provides an automated error detection capability ensuring accurate interfaces.
- The interfaces are also grouped based on commonality and variability. Those with commonality are typically reusable without tailoring while those with variability have to be tailored to the application requirements. Grouping by commonality and variability also promotes use of domain specific code generation like that provided by the STARS Software Engineering Environment (SEE).



MSS Design Reuse/Tailoring Concept



Organization

- Interfaces grouped in compatible Ada packages
- Commonality and variability

Benefit

- Promotes use of domain specific SW generation

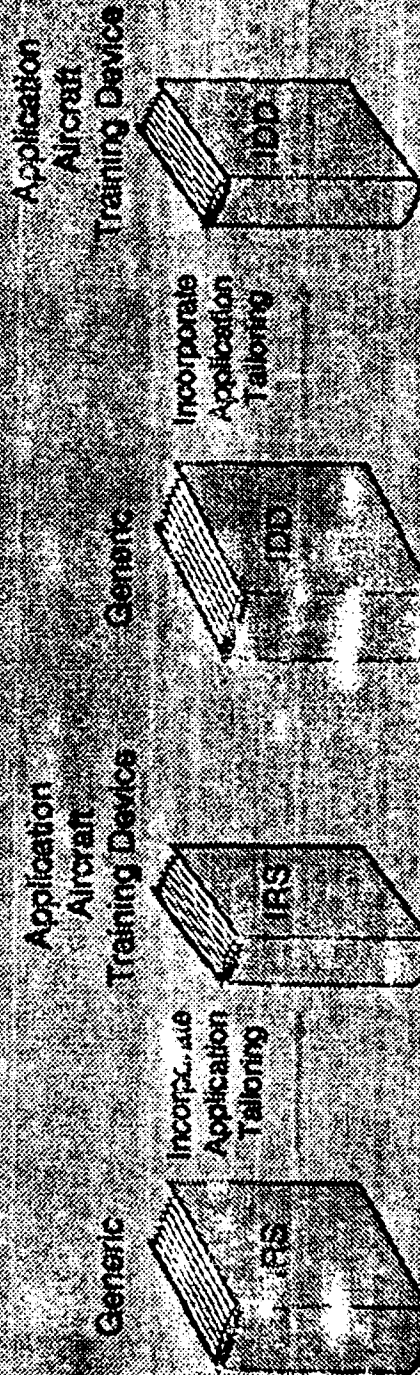

HARDWARE/SOFTWARE ALLOCATION

- Modular Simulators provide system and segment developers numerous design options. The system designer selects the communication media for inter segment communication while the segment designer is free to select a different media for internal segment communication. This flexibility also applies to protocol selection, in that the segment designer may use an internal protocol which is different than the system level protocol.
- With the exception of the virtual network interface hardware, a segment designer is normally free to select hardware that best suits the application. The same is true for computational system decisions.
- Another option available in a Mod Sim is the ability to allocate two or more segments to a single processing resource. This provides the prime the flexibility to make "best system design" decisions. In this way, a developer, who is responsible for more than one segment, can optimize computer hardware performance and cost.
- Nothing about the Mod Sim architecture imposes any requirements on the internal segment design or architecture, provided communication between segments is message based and uses the standardized application interface.



MSS Design Hardware/Software Allocation



Provides a flexible architecture with the choice of:

- Communication media
- Protocols
- Hardware
- Computational systems
- Allocation of segments to CPUs

MSS architecture does not constrain internal
segment design/architecture

BACK DOOR INTERFACES

- The Mod Sim architecture is rigid concerning inter segment communication. It does however recognize that there are special cases when communication across the virtual network is not appropriate. In those instances, Mod Sim allows the use of "back door" interfaces. For example, imaging data is not transmitted on the virtual network. This data must be transmitted through a back door interface to any segment that requires the information.
- In some instances the coupling requirements are tight and the inherent one frame delay with communication across the virtual network could adversely affect the simulation.
- Installed avionics systems, in addition to having tight coupling requirements, are typically specific to a single application and do not lend themselves to Mod Sim standardization, i.e. they are not reusable and they drive up costs of reusable modules and network solutions and as such should be treated on a case by case basis.
- In the diagram, the avionics processor on the left will physically reside in the computational complex of one of the two segments with a 1553 bus connected between the segments providing the back door connection. The avionics processor on the right communicates with only one segment directly, and therefore it is not a back door interface, even though the processor may be collocated in another segment. In general, back door interfaces should only be used as a last resort, since they are exceptions to the fundamental Mod Sim architecture and hamper reuse.



MSS Design Back Door Interfaces



Permitted for special applications only

- > Video or graphical imaging data
- > Tight coupling requirements
- > Installed avionics buses and processors

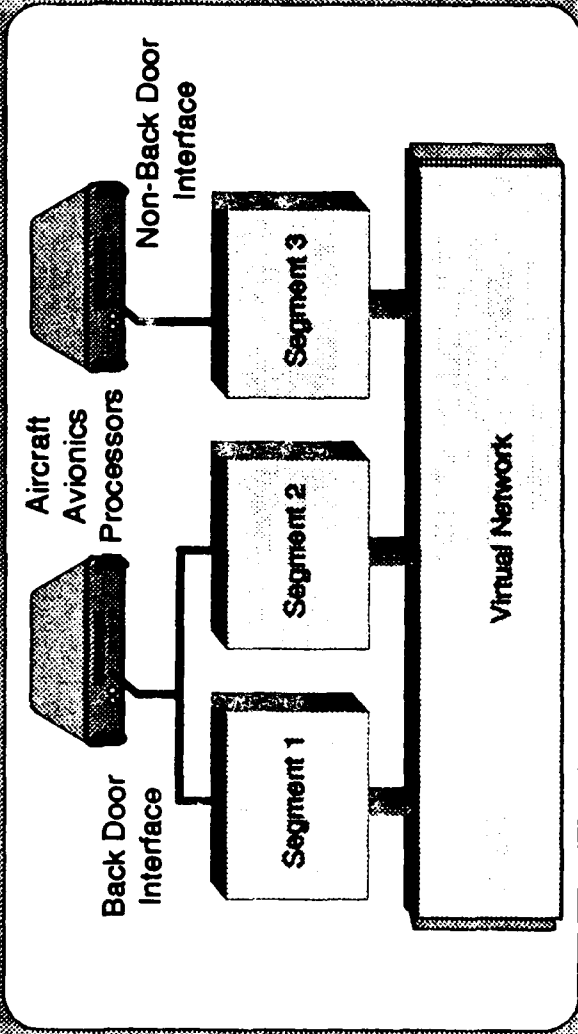

NOTIONAL SOFTWARE ARCHITECTURE

- Although Mod Sim does not impose requirements on internal segment software architecture, there is a suggested software architecture. In this architecture each segment's software is treated as a Computer Software Configuration Item (CSCI), the segment functions are designated as Computer Software Components (CSCs) and Mod Sim objects (i.e., individual Ada procedures) as Computer Software Units (CSUs).
- Each segment should be designated as a CSCI. A CSCI, by MIL-STD-480 definition, is an item designated for configuration management by the contracting agency. Since one of the original goals of the Mod Sim program was to allow separate procurement of modules (now segments), this is an appropriate designation. What makes up a CSCI is predetermined by the Mod Sim architecture defined in the applicable volume of the generic specification.
- In DOD-STD-2167A, a CSCI consists of CSCs. The corollary in Mod Sim is that a segment consists of subsystems and functions. Hence subsystems and functions become individual CSCs. The actual number of CSCs in a segment depends on the tailoring required for the application.
- The lowest element of this hierarchy is a CSU. It is equivalent to a Mod Sim object and is the actual coded procedures and functions. The units are defined during the software design phase of the program. This architecture is, by design, consistent with DOD-STD-2167A as it is currently defined.



MSS Design Notional Software Architecture

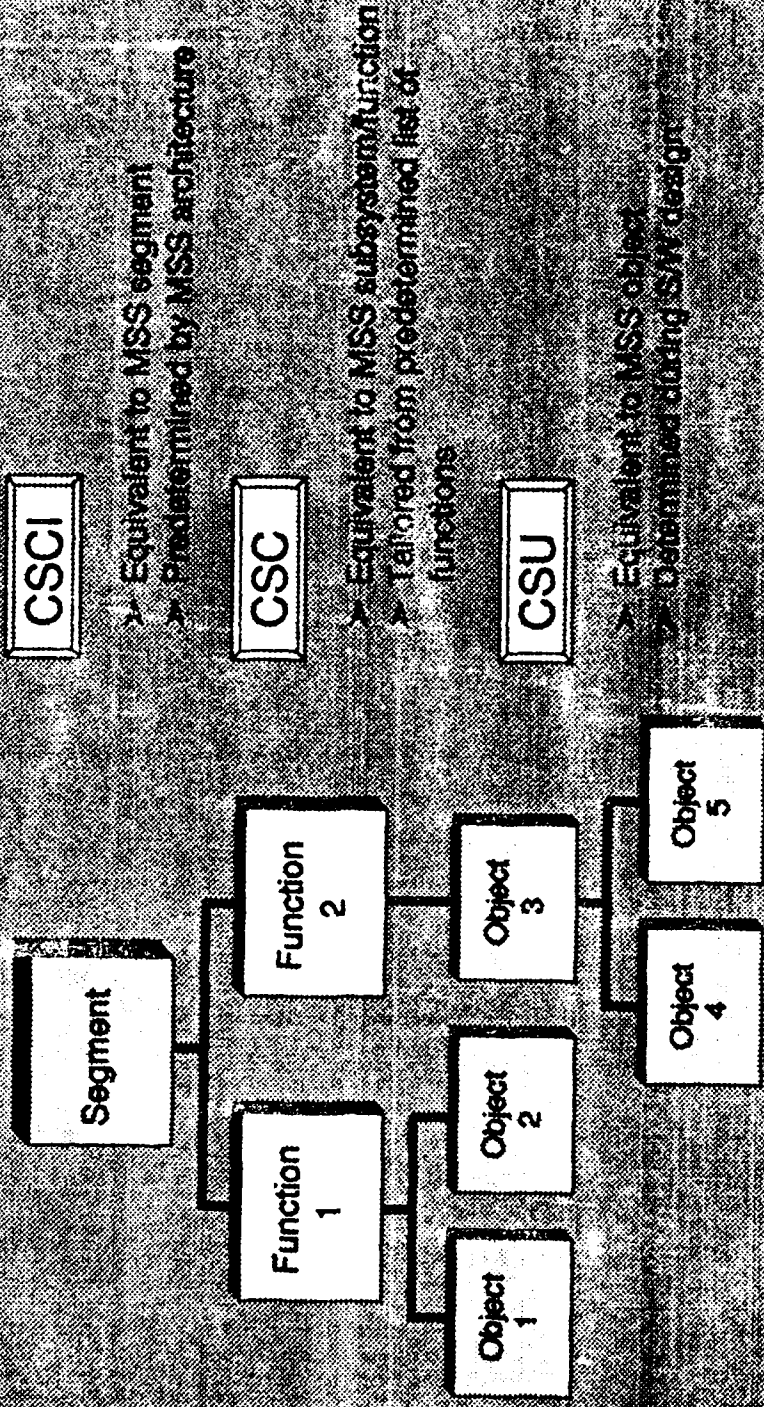

INTEGRATION

- One of the key factors in the Mod Sim architecture is the loose coupling between segments. Loose coupling inherently results in reduced number of interfaces and therefore simpler integration. A typical Mod Sim integration can be accomplished faster and with less risk than with traditional integration methodologies. It is estimated, and the demonstration effort has shown, that the savings can be as much as 50% or 60% with respect to traditional program practices.
- One reason why the loose coupling between segments speeds up integration is that the Mod Sim inter segment interfaces are relatively small. The fact that individual segments are relatively independent of other segments means that the segments can be more rigorously and comprehensively tested in a stand-alone environment, prior to integration. Typically, the more testing prior to integration, the fewer problems encountered during integration.
- Management of the interface through the use of an Ada compiler reduces risk by minimizing interface errors. Another contributing factor to improved integration is the ability to reuse prior systems engineering processes and products. In addition to the systems engineering reuse, the ability to reuse previously validated components and test harnesses provide predictability in performance which also minimizes integration problems.



MSS Design Integration

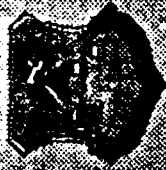

Mod Sim Enhances Integration

- > Loose Coupling
- > Integration is "built-in" to the MSS concept
- > Interface between major components is managed by Ada compiler
- > Reusable system engineering process and products
- > Reuse of previously validated components and test harnesses
- > Rigorous, comprehensive segment test prior to integration

Demonstrated Benefits

- > Shorter integration schedule
- > Lower risk integration
- > Estimate 50-60% savings during integration
- > Parallel development

INTEGRATION 2

- In a traditional simulator development, the hardware and software integration phase involves a gradual build up of components and software into subsystems, subsystems into major subsystems, major subsystems into stations, and finally, stations are integrated to form a training device. In a Mod Sim, the architecture is flat, allowing segments to be developed and tested in parallel, and subsequently integrated one at a time during the segment integration phase. Typically, an individual segment can be integrated to the system in a matter of days.
- During the HSI phase of a traditional simulator development, the entire set of software interfaces are tested and verified. Whereas in a Mod Sim, a large portion of the interfaces are verified during the individual stand-alone segment tests, leaving only the application and back door interfaces requiring verification during the segment integration phase. The net result is a much smaller development schedule, and thus less cost for a Mod Sim as opposed to more traditional simulators.

048-104-1



MSS Design Integration

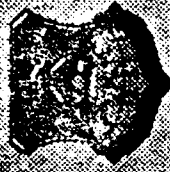

Traditional
Simulator
Test and
Integration

Mod Sim
Test and
Integration

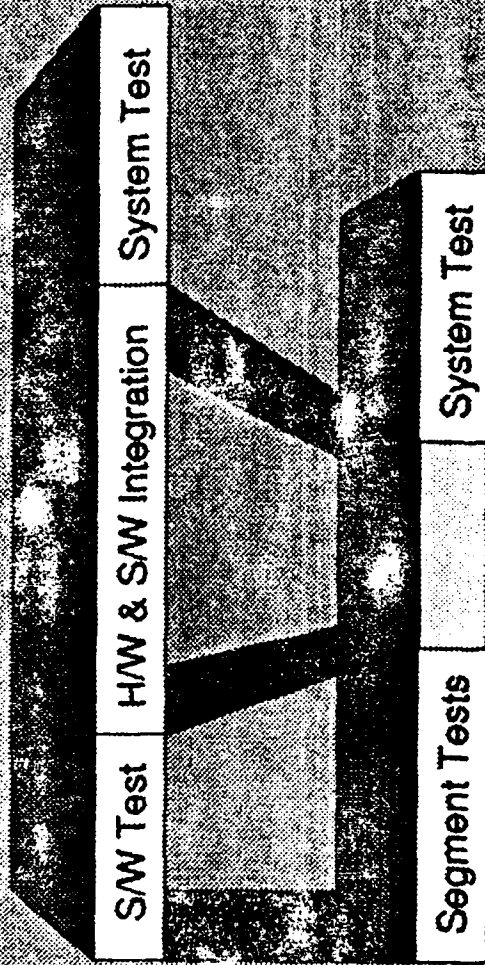

Segment
Integration
(typically 1 to 2 days per segment)

TEST CONCEPT

- The test approach for a Mod Sim is divided into five phases. The first phase is segment development testing conducted by the segment developer. During this phase the segment acceptance test procedures are developed and run to provide confidence that the segment is ready for formal acceptance testing.
- During the second phase, the segment is formally tested as a stand-alone device prior to system level integration. For those instances in which the segment is subcontracted, these tests constitute the supplier acceptance tests. When the segment is developed by the prime, these tests may be formal or informal depending on the amount of risk the prime is willing to accept.
- After acceptance, the segment is submitted for integration and informal testing. The segment integration is controlled in accordance with a predetermined sequence. Throughout this phase the system level test procedures are developed and run prior to entering formal system level testing.
- Formal system level testing normally occurs in two phases; in-plant qualification testing and on-site acceptance. During in-plant testing the full set of system level test procedures are run with man-in-the-loop for customer buy-off. These tests are no different than system level tests for traditional devices.
- After the device is shipped, installed and checked out, it is ready for formal acceptance test. This consists of a top level subset of the formal system tests to ensure the device operates as it did in-plant. Successful completion of this test phase results in final customer acceptance.



MSS Design Test Concept

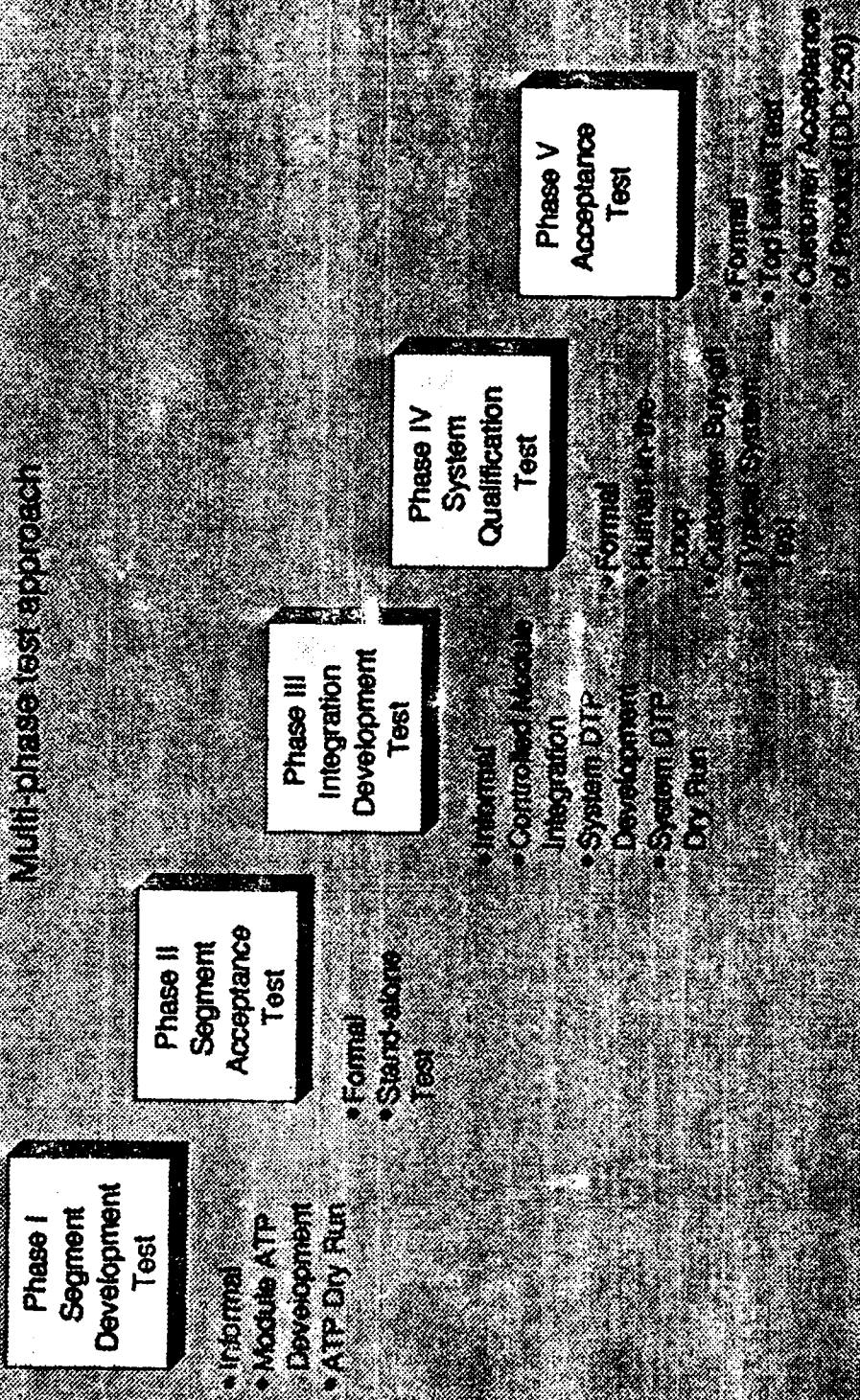

TEST EQUIPMENT

- A Mod Sim requires two unique pieces of test equipment: a segment tester and a network analyzer. The segment tester is a system that emulates all the segment that are not under test. Its primary functions are to evaluate performance of individual segments in a stand-alone mode and to verify that the segment conforms to the interface requirements. Some potential uses include segment software testing, support of system integration and system diagnostics.
- A network analyzer is absolutely requisite to a Mod Sim development. It provides the capability to measure network latency, which is necessary to debug interface problems. In every program there are spare capacity requirements, and a network analyzer is the only tool capable of determining network spare time effectively. Oftentimes system debugging requires the ability to examine the performance parameters of the network, such as bus bandwidth utilization, message integrity and others. The analyzer provides these capabilities. Another use for a network analyzer is to provide network hardware diagnostics. In all these instances it is important that the analyzer not introduce any problems. A good network analyzer should be able to attach to the network unobtrusively.



MSS Design Test Equipment



Unique Test Equipment

- Segment Tester
 - Evaluate segment stand-alone performance
 - Verify interface performance

Future Potential

- Segment S/W Tester
- System Integration Tool
- System Diagnostic Tool

Network Analyzer

- Measure network latency
- Determine spare network capacity
- Examine network performance parameters
- Network diagnostics
- Unobtrusive observer

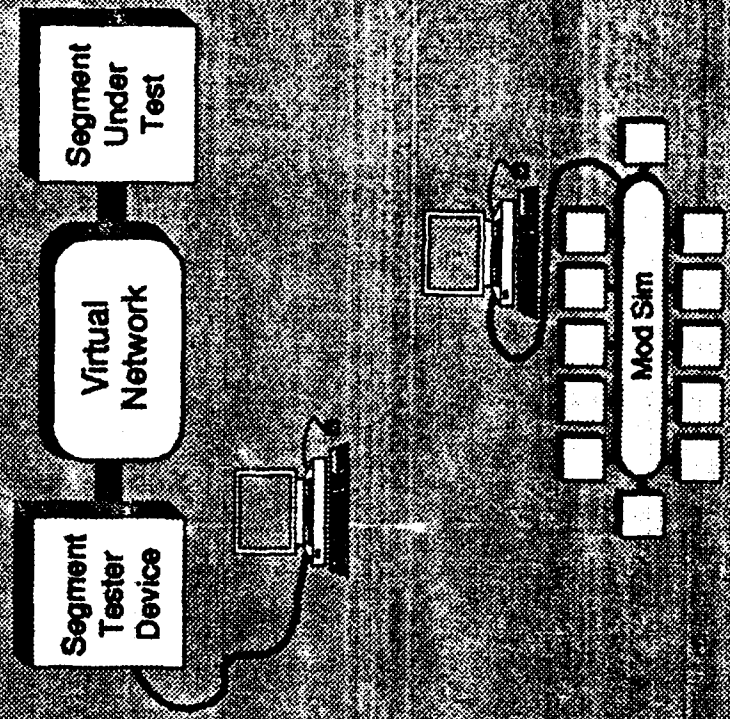

LESSONS LEARNED

- Many lessons were learned over the course of the Mod Sim project. With respect to specifications, it was proven that the generic Mod sim specification, and therefore its architecture, was tailorable to several applications. Also, managing the application interfaces through a software compiler, with regularly scheduled updates, greatly enhances the integration effort. Another item which proved to be critical was the requirement for careful definition of system modes and states. While this is important to any system, it is especially important to a Mod Sim with so many independent entities (segments).
- Regarding subcontracting, the nature of a Mod Sim, with potentially many partners, absolutely requires clear definition of work statements and sound management of the subcontracts by the prime. Having many subcontractors also requires that documentation requirements and coding standards be identified early in the program to ensure consistent products across the subcontractors. Even though Mod Sim segments are tested and accepted as stand-alone devices, it is imperative that segment developers have clearly defined responsibilities subsequent to segment acceptance. In the interest of commonality and reducing acquisition and support costs, it is tempting to impose common hardware requirements on the subcontractors. This, unfortunately, carries a certain amount of risk in that the "best solution" for a given segment may be eliminated. Therein lies one of the more fundamental trade studies which must be accomplished on a Mod Sim program.

MSS Design Lessons Learned

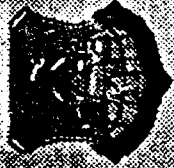

Specifications

- Several applications have proven that the Med Sim architecture is tailorable
- Configuration management, and scheduler baseline updates of the interface is important
- Careful and detailed specification of system modes and states is critical

Subcontracting

- Depending on the quantity of subcontracting, subcontract management can be a significant cost
- Data items, coding and documentation standards should be identified by SRR
- A segment builder's role after formal segment acceptance must be bounded
- Common hardware components can save overall cost but may increase risk

LESSONS LEARNED 2

- Elemental to a Mod Sim is the relative independence of the various segments. In order to test segments stand-alone and to integrate them one at a time, a segment tester is an absolute requirement. The segment tester developed for the F-16 Demonstrator program was invaluable, but it could have been better. For future Mod Sim programs, the tester should be capable of automated interface management, debugging support and integration support.
- Developing test procedures that are comprehensive enough to verify the acceptability of a Mod Sim segment can be, at best, difficult. In a traditional simulator, for example, there are no separate test procedures for the flight dynamics portion of the overall flight simulation. Flight dynamics is tested in conjunction with the flight controls, flight station and propulsion function testing, using system level test procedures. Flight dynamics in a Mod Sim program however, is tested stand-alone, using detailed functional test procedures. In order to test the module for its ability to meet system level requirements, the interfaces with the other related functions must be accurately simulated by some means to verify proper operation of the flight dynamics segment. The prime contractor has an equally difficult task in reviewing and approving segment level test procedures, since in all likelihood the prime is not knowledgeable in the segment domain.
- A nuance of Mod Sim is that segments are usually accepted before they are integrated into the system. Even though segments are rigidly tested, problems can occur during system integration that require corrections. In these instances, provisions must be made for retest at the segment level to ensure proper segment operation in a stand-alone mode and to ensure that the segment level test procedures reflect segment functionality subsequent to the correction. A lesson learned

from the F-16 Demonstrator program concerned the use of FDDI as the communication media. if FDDI is used, it is imperative that a bus analyzer be provided to assist in debugging the interfaces. FDDI is still maturing and tends to fail relatively often as compared to other more mature media.

- From a logistics perspective, a Mod Sim implementation could increase support costs due to a proliferation of computational hardware types. it is important that the application developer recognize this possibility and take appropriate steps to control these costs. This factor should be an important consideration during application tailoring. This is probably not a lesson learned, but rather a confirmation of previous thinking.
- The last lesson learned concerns User's guides. On traditional simulators, User's guides are normally limited to major subsystems. In a Mod Sim, where the Prime integrates after segment/module acceptance, a User's guide should be a required for each of the segments/modules.



MSS Design Lessons Learned



Testing Integration

- The segment tester is a very important device and could be improved to add automated capabilities for interface management, debugging and integration support
- Test procedures at the segment level are difficult to develop
- The prime must be knowledgeable at the segment level to approve test procedures
- Integrated test procedures should include related provisions at segment level
- When FDDI is used as the communication media a Bus Analyzer is a must

Logistics/Implementation

- The variability of computers among modules can increase maintenance costs
- A user's guide for each module/segment should be a requirement

MSS APPLICATIONS INTRO

- This portion of the briefing addresses past and present applications for the Mod Sim concept and how MSS is keeping pace with technology.



Modular Simulator System



Project Overview

Modular Simulator System Design

Modular Simulator System Applications

APPLICATION HISTORY

- Mod Sim concepts have been applied to a variety of projects and taken to various levels of maturity.
- Funding limitations have restricted the number of projects taken into the test phase.
- Much has been learned by applying the Mod Sim concept to early phases of ADST, CCTT, STARS, F-22, etc. It was not necessary to fully implement and test simulators to confirm that the architecture:
 - A. Is tailorable to diverse applications;
 - B. Enhances the reuse potential of segments across multiple applications;
 - C. Relieves application developer of many architecture development tasks providing a head start on implementation.



MSS Applications Application History

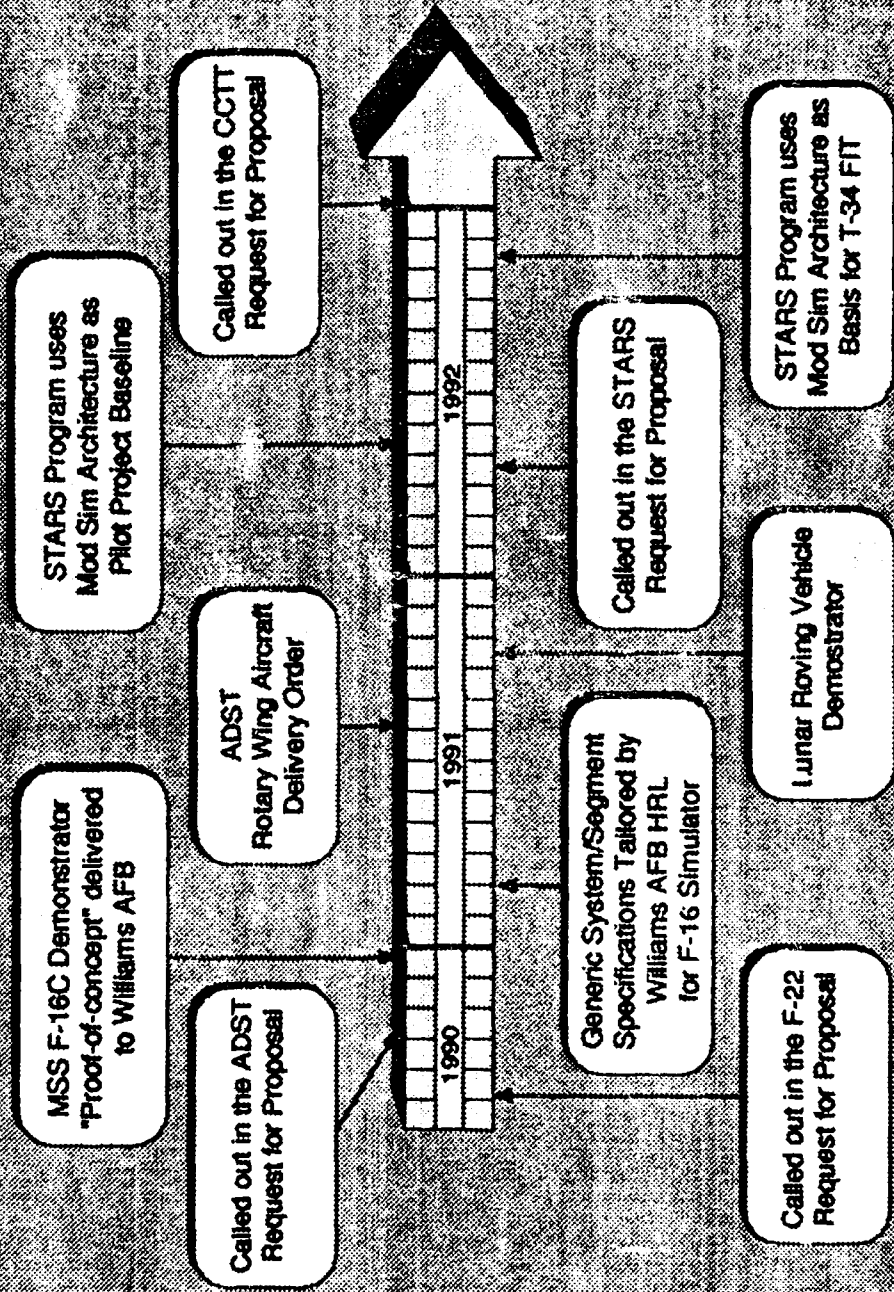

CONCEPT EVOLUTION

- Phase III of the project was completed early in 1990 with demonstration of the "Proof-of-concept". Several follow-on options were suggested by the final ISWG. These options were exercised to add tailoring instructions to the System Segment Specifications, study the possibility of interoperability with other simulators, create Design and Management Guides and the architecture was revised to allow for optional FDDI and XTP "Virtual Network" implementations and multiple S/W segments in a H/W module.
- Additionally, the "Structured Modeling" approach to design was applied to the segment internal architecture and the SPC Synthesis reuse process was utilized to examine the possibility of automating tailoring.

MSS Applications Concept Evolution

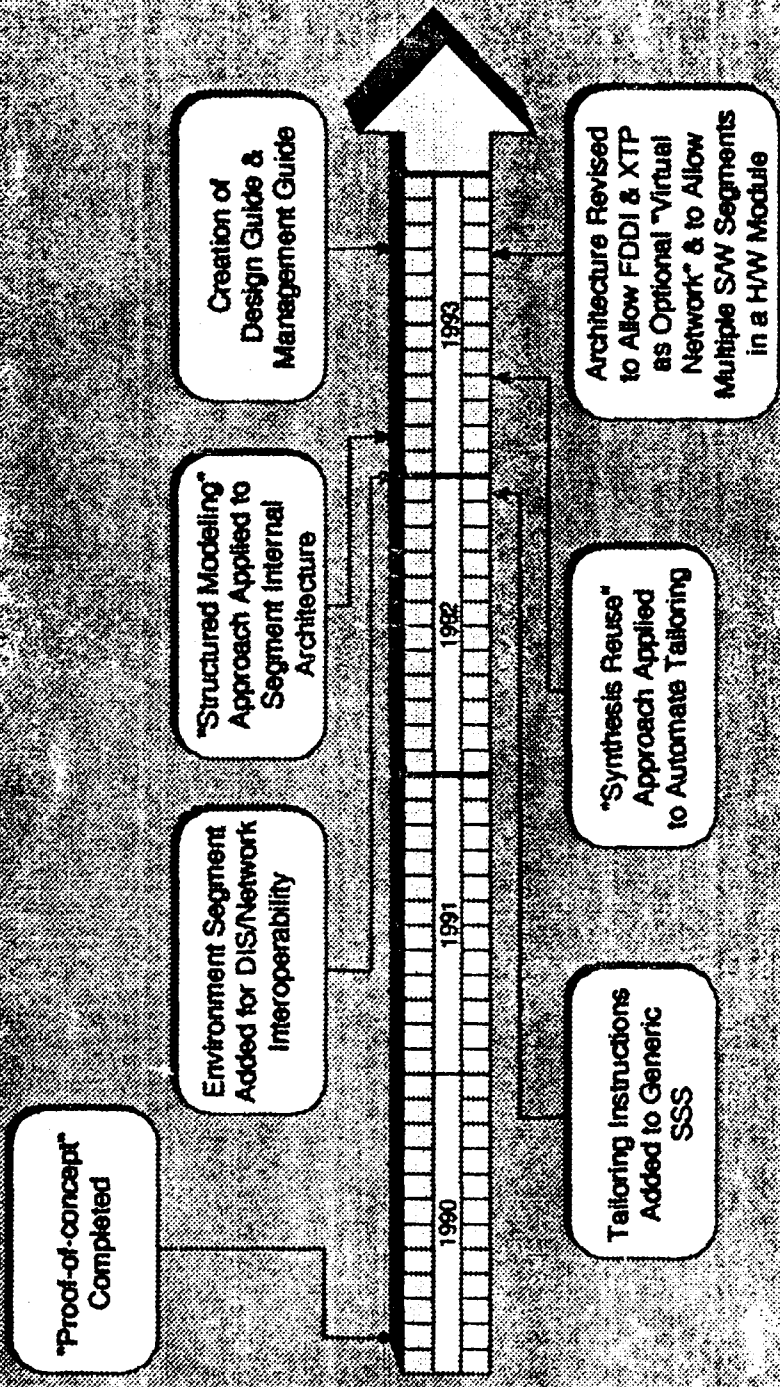

POINTS OF CONTACT

- The government point of contact is James Basinger and the industry point of contact is William Tucker (Boeing Mod Sim program manager).



MSS Applications Points Of Contact

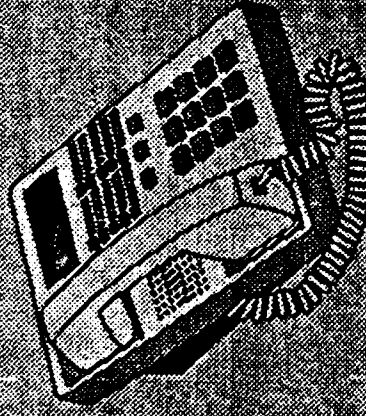
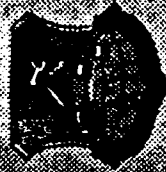

Industry
The Boeing Co.
William V. Tucker (206)461-3120
499 Boeing Blvd.
P.O. Box 240002
Huntsville, AL 35824-6402

Government
United States Air Force
James Basinger (513)255-7184
Aeronautical Systems Center
Training Systems System Program Office
Wright Patterson AFB, Dayton, OH

ACTIVE PAGE RECORD

PAGE NO.	REV LTR	ADDED PAGES				PAGE NO.	REV LTR	ADDED PAGES			
		PAGE NO.	REV LTR	PAGE NO.	REV LTR			PAGE NO.	REV LTR	PAGE NO.	REV LTR
1	.	40	.								
2	.	41	.								
3	.	42	.								
4	.	43	.								
5	.	44	.								
6	.	45	.								
7	.	46	.								
8	.	47	.								
9	.	48	.								
10	.	49	.								
11	.	50	.								
12	.	51	.								
13	.	52	.								
14	.	53	.								
15	.	54	.								
16	.	55	.								
17	.	56	.								
18	.	57	.								
19	.	58	.								
20	.	59	.								
21	.	60	.								
22	.	61	.								
23	.	62	.								
24	.	63	.								
25	.	64	.								
26	.	65	.								
27	.	66	.								
28	.	67	.								
29	.	68	.								
30	.	69	.								
31	.	70	.								
32	.	71	.								
33	.		.								
34	.		.								
35	.		.								
36	.		.								
37	.		.								
38	.		.								
39	.		.								

REVISIONS			
LTR	DESCRIPTION	DATE	APPROVAL