



AN EFFICIENT DATA ACQUISITION
METHODOLOGY FOR BANDPASS SONAR SIGNALS

AR-006-300

T.R. JACKSON

MRL-TN-647

NOVEMBER 1993

AD-A277 066



S DTIC ELECTE D
E MAR 18 1994

DTIC QUALITY INSPECTED

APPROVED
FOR PUBLIC RELEASE

C Commonwealth of Australia

MATERIALS RESEARCH LABORATORY

DSTO

An Efficient Data Acquisition Methodology for Bandpass Sonar Signals

T.R. Jackson

MRL Technical Note
MRL-TN-647

Abstract

The function of a data acquisition system is to digitise data from a number of separate channels, and store these samples for later analysis. Sonar systems are typically multi-channel, and the associated data acquisition systems are required to handle data at high data rates. The high data rates involved in digitising bandpass sonar data usually mean that the only viable storage methods available are large magnetic tapes, with data recorded on high-speed tape recorders. One of several disadvantages of this type of storage method is that the tapes have to be replayed through special decoders to obtain the data in a form ready for analysis. This is a time consuming process, delaying the analysis and interpretation of the data. An alternative method of sampling bandpass sensor data which results in a much lower data rate is presented in this report. The resulting lower data rate allows advantage to be taken of the recent improvements in computer storage technology, enabling a data acquisition system to be constructed that is computer-based, and utilises computer storage devices as its primary storage media. The advantage of this storage method is that the data is in computer readable form, ready for immediate analysis. This work was carried out in support of Navy Task NAV 92/401 and an application of the theory of the AN/SQS 56 sonar is presented in the Appendices.

For	
DTIC TAB	X
Unannounced	
Justification	
By	
Distribution	
Availability Codes	
Dist	Availability, or Special
A-1	

35 PG 94-08746



DEPARTMENT OF DEFENCE
DSTO MATERIALS RESEARCH LABORATORY

94 3 18 '01 D

Published by

*DSTO Materials Research Laboratory
Cordite Avenue, Maribyrnong
Victoria, 3032 Australia*

Telephone: (03) 246 8111

Fax: (03) 246 8999

© Commonwealth of Australia 1993

AR No. 008-300

APPROVED FOR PUBLIC RELEASE

Contents

1 Introduction	5
2 Bandpass Signals	5
2.1 Complex Envelope of Bandpass Signals	5
2.2 Bandpass Sampling Techniques for Bandpass Signals	7
3 Quadrature Sampling - An Alternative Method	8
3.1 Integer Band Shifting	8
3.2 An Alternative Technique for Complex Demodulation using Integer band shifting	10
4 An Efficient Data Acquisition System for Bandpass Signals	14
5 Summary	16

Appendices

A Complex Demodulation	19
A.1 Spectrum of a complex demodulated signal	19
B Overview of Quadrature Beamforming	21
B.1 Review of the Conventional Digital Beamformer Structure	21
B.2 The Quadrature Beamformer Structure	22
C The AN/SQS-56 Sonar System	27
C.1 Overview	27
D Data Acquisition for the AN/SQS-56 Sonar	31
D.1 Proposed Sampling Method for Active Data Stream	31
D.2 Data Acquisition System Proposal	33
D.3 Acquisition and Storage of Ancillary Ship Data	35

List of Figures

1	Spectrum of bandpass signal	6
2	Conventional Quadrature Demodulation	7
3	Digital complex demodulation of a bandpass signal	8
4	Integer Band-shifting of Bandpass Signals	9
5	An alternative technique for complex demodulation using integer band shifting	10
6	Functional block diagram of a computer-based data acquisition system	15
B-1	Conventional Time Domain Delay-Sum Digital Beamformer	21
B-2	Quadrature beamformer with Pre-beamforming interpolation	24
C-1	AN/SQS-56 Sonar - Functional block diagram	28
C-2	Functional block diagram of Array Interface and Receiver Subsystems	28
D-1	Proposed SQS-56 Data Acquisition System	34

List of Tables

C-1	Active Pre-amplifier Characteristics	29
D-1	Possible sampling frequencies for integer band shifting, $f_{tx} = 8400$ Hz	32
D-2	Possible sampling frequencies for integer band shifting, $f_{tx} = 6700$ Hz	32
D-3	Possible sampling frequencies for integer band shifting, $f_{tx} = 7500$ Hz	32

1 Introduction

The function of a data acquisition system is to digitise data from a number of separate channels, and store these samples for later analysis. The majority of active sonar systems have a large number of channels, resulting in high overall data rates when the signals from these channels are digitised for storage. In the past, the only storage medium capable of handling these high data rates was large magnetic tape used with high speed tape recorders and specialised encoding hardware. This approach generates recorded data formats which require further processing through decoders to convert them to a computer readable form, making it costly in both time and money. However, an alternative approach eliminating some of the drawbacks of this method is now possible, and is the subject of this report.

Computer storage technology has reached the point where it is possible to store in excess of one gigabyte of data on a single disk, with sustained data rates of hundreds of kilobytes per second. With this level of technology, it is now feasible to construct a cost-effective data acquisition system for some sonar systems where the digitised data is stored directly in computer-readable form. Such a system eliminates the need for pre-processing of the recorded data to obtain the data in a computer-readable form.

This report outlines a method for efficiently digitising bandpass sonar signals. A data acquisition system using this method would be able to use current computer storage technology to store the digitised data in computer-readable form. Section 2 gives a brief introduction to bandpass signals, describing how they can be represented in terms of their lowpass complex envelope, and how bandpass sampling techniques can be utilised to sample these signals at a rate consistent with twice the signal bandwidth. Section 3 outlines a method of obtaining a sampled representation of the complex envelope that is only applicable to a certain class of bandpass signals.

An outline of how these techniques can be applied to make a data acquisition system for bandpass sonar data which is efficient, and uses computer-based storage, is presented in Section 4. A summary is given in Section 5. An application of the data acquisition method detailed in this report to the AN/SQS-56 hull mounted sonar is described in Appendices C through D.

It is important to note that the mathematics in this report is not presented rigorously, but are presented in such a way as to enable the concepts to be understood easily. A more rigorous mathematical approach to the techniques outlined can be found in the references given in the bibliography.

2 Bandpass Signals

2.1 Complex Envelope of Bandpass Signals

Consider a bandpass signal $x(t)$ of bandwidth W , centred at frequency f_0 with $f_0 \gg W$. Let $X(f)$ denote the Fourier transform of the signal $x(t)$, which for $x(t)$ real is defined

as follows

$$X(f) = \begin{cases} X_-(f) & -\left(f_o + \frac{W}{2}\right) \leq -f \leq -\left(f_o - \frac{W}{2}\right) \\ X_+(f) & \left(f_o - \frac{W}{2}\right) \leq f \leq \left(f_o + \frac{W}{2}\right) \\ 0 & \text{otherwise} \end{cases} \quad (1)$$

$X_-(f)$ and $X_+(f)$ respectively denote the negative and positive halves of the spectrum $X(f)$.

This spectrum is shown in figure 1 below

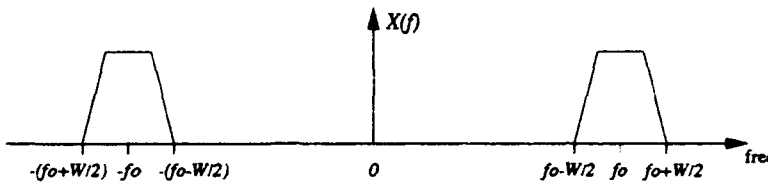

Figure 1: Spectrum of bandpass signal

It is well known [1], [2] that a bandpass signal, such as $x(t)$ above, can be represented in terms of its in-phase and quadrature components, as given below

$$x(t) = x_I(t) \cos(2\pi f_o t) - x_Q(t) \sin(2\pi f_o t) \quad (2)$$

where $x_I(t)$ and $x_Q(t)$ are respectively the in-phase and quadrature components of $x(t)$. If $x(t)$ has bandwidth W , then the in-phase and quadrature components of $x(t)$ will each be lowpass signals of bandwidth $\frac{W}{2}$.

The in-phase signal $x_I(t)$ is typically obtained by modulating the signal $x(t)$ by a carrier signal of frequency f_o ($2 \cos(2\pi f_o t)$), and lowpass filtering to remove the sum frequency term. Similarly $x_Q(t)$ is obtained by modulating $x(t)$ with a carrier 90° out of phase with the previous carrier ($2 \sin(2\pi f_o t)$), and lowpass filtering. i.e.

$$x_I(t) = 2 \cos(2\pi f_o t) x(t) \Big|_{LP} \quad (3)$$

and

$$x_Q(t) = 2 \sin(2\pi f_o t) x(t) \Big|_{LP} \quad (4)$$

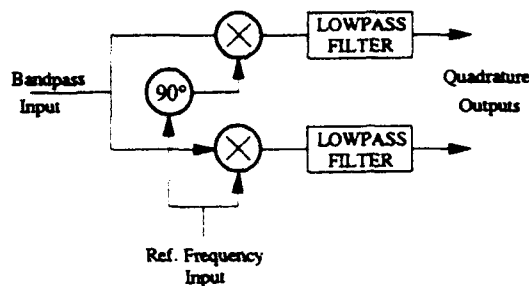

Figure 2: Conventional Quadrature Demodulation

where $\Big|_{LP}$ denotes the lowpass filtering operation. The conventional method of obtaining the in-phase and quadrature signals is via two analog multipliers or mixers and a single 90° phase shift, as shown in figure 2.

The in-phase and quadrature components of the bandpass signal can be combined as follows, to form a complex-valued signal $x_C(t)$, which is the complex envelope of the original bandpass signal.

$$x_C(t) = x_I(t) + jx_Q(t) \quad (5)$$

Hence all the information in the original bandpass signal $x(t)$ is contained in the complex valued lowpass signal, $x_C(t)$, of bandwidth $\frac{W}{2}$.

2.2 Bandpass Sampling Techniques for Bandpass Signals

If the complex signal is sampled at a rate consistent with its bandwidth of $\frac{W}{2}$ (i.e. sampled at W samples per second) then the complex samples provide a discrete-time representation of the original bandpass signal, with a sample rate consistent with the signal bandwidth. This provides a much more efficient sampling method (in terms of data rate) for bandpass signals than conventional lowpass sampling techniques, which require a sampling rate of twice the highest frequency of interest.

The lowpass complex signal $x_C(t)$ is typically sampled by forming the two real signals $x_I(t)$ and $x_Q(t)$, as shown in figure 2, and then sampling each of these signals at a rate of W samples per second. This gives a combined data rate of $2W$ real samples/second or W complex samples per second. One of the problems of sampling $x_C(t)$ using this method is that DC biases are often introduced into the signals $x_I(t)$ and $x_Q(t)$ due to the non-ideal nature of the analog mixing, which can cause problems when the in-phase and quadrature signals undergo further processing. This problem is often overcome by sampling the original bandpass signal using conventional sampling techniques, and performing the quadrature demodulation digitally as shown in figure 3 below.

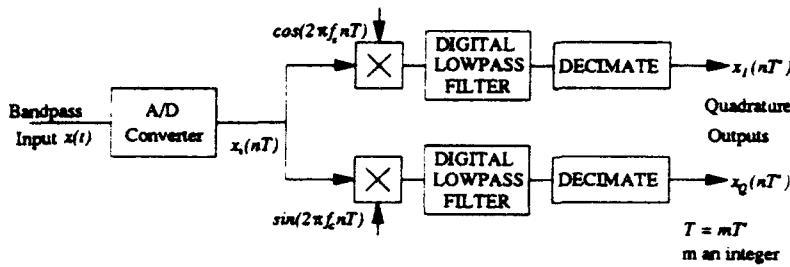

Figure 3: Digital complex demodulation of a bandpass signal

Other bandpass sampling techniques exist for efficient sampling of bandpass signals such as sampling of the analytic signal (i.e. the sum of the signal plus its Hilbert transform) and second order sampling (sampling of the signal and its quarter wave translation at rates consistent with the signal bandwidth). More details on these techniques, and on quadrature sampling can be found in references [1] - [6].

3 Quadrature Sampling - An Alternative Method

3.1 Integer Band Shifting

For bandpass signals, it can be shown that if a suitable relationship exists between the signal bandwidth and the highest signal frequency, then a sampling frequency can be chosen which need not be any greater than twice the signal bandwidth, instead of twice the highest frequency of the signal. Consider the spectrum of the bandpass signal shown in figure 1. Let f_U denote the upper band edge and f_L denote the lower band edge.

$$f_U = f_o + \frac{W}{2} \quad (6)$$

$$f_L = f_o - \frac{W}{2} \quad (7)$$

$$W = f_U - f_L \quad (8)$$

where f_o is the centre frequency of the band and W the bandwidth. The upper and lower band edges, f_U and f_L , include guard bands (i.e filter transition bands) so they in effect denote the edges of the stop bands of the bandpass signal.

Integer band shifting is achieved by intentionally under-sampling the bandpass signal with respect to its highest frequency, but not its bandwidth. Use of a suitable sampling frequency results in the positive and negative halves of the original bandpass spectrum, F_+ and F_- respectively, being shifted down to base band without ambiguous aliasing. There are two possibilities for a suitable sampling frequency. The first is where the

sampling frequency f_s and the lower and upper band edges f_L and f_U are related as follows

$$f_L = kf_s \tag{9}$$

$$f_U = \left(k + \frac{1}{2}\right)f_s, \quad \text{where } k = 1, 2, 3, 4, \dots \tag{10}$$

The second is where the lower and upper band edges f_L and f_U relate to the sampling frequency f_s as follows

$$f_L = \left(k - \frac{1}{2}\right)f_s \tag{11}$$

$$f_U = kf_s, \quad \text{where } k = 1, 2, 3, 4, \dots \tag{12}$$

To avoid aliasing, the Nyquist criterion requires that

$$f_s \geq 2(f_U - f_L) \tag{13}$$

Because f_L and f_U include guard bands, equality actually applies in equation (13), giving

$$f_s = 2(f_U - f_L) \tag{14}$$

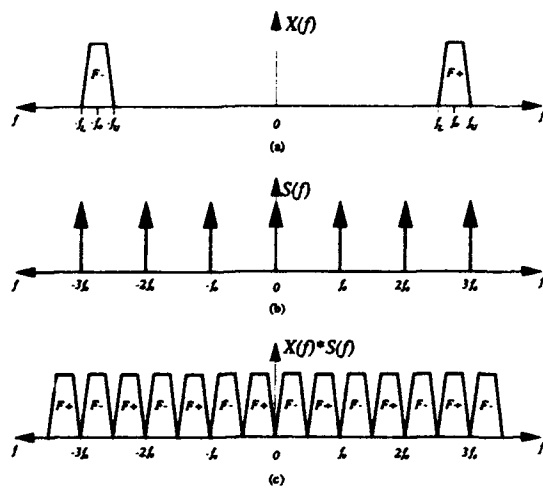

Figure 4: Integer Band-shifting of Bandpass Signals

Figure 4 shows an example where (11) and (12) apply. In the example shown, the upper frequency limit f_U is three times the sampling frequency f_s . $X(f)$ and $S(f)$, shown in figures 4(a) and 4(b) are the spectra of the original bandpass signal and the sampling

signal respectively. Figure 4(c) is the spectrum of the sampled bandpass signal, which can be found by convolving $X(f)$ and $S(f)$. Figure 4(c) shows that the spectrum of the sampled signal results in F_+ and F_- being shifted down to baseband without ambiguous aliasing.

It is of interest to note that the application of the second solution, and in particular equation 12, results in the positive half of the original spectrum F_+ being shifted to the negative half of the resulting spectrum, and F_- being shifted to the positive half. This does not have any undue effect on the further processing of the sampled signal. When (9) and (10) are used, F_+ and F_- are shifted to the positive and negative sides of the resulting spectrum respectively.

Because of the somewhat restrictive relationship required for this sampling technique to be useable (between the upper and lower band edges, f_L and f_U , and the sampling frequency, f_s , as shown in equations (14) and either (9) and (10), or (11) and (12)), it is not a generally applicable technique and therefore is not well known or widely documented. Some details of this technique can be found in [7] - [9].

3.2 An Alternative Technique for Complex Demodulation using Integer band shifting

If the nature of the bandpass signal is such that integer band shifting on sampling is possible, (as described in section 3.1), then another technique [9] exists for obtaining sampled versions of the in-phase and quadrature signals. This alternative technique avoids the analog mixing and filtering processes (and the associated problems) required for conventional quadrature demodulation as shown in figure 2, and also avoids the high data rates associated with the digital technique which is shown in figure 3.

Consider the technique outlined in figure 5.

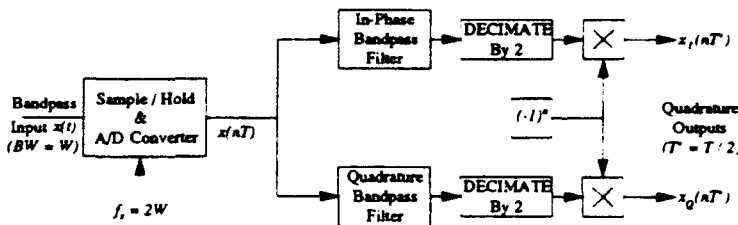

Figure 5: An alternative technique for complex demodulation using integer band shifting

The spectrum of the sampled signal $x(nT)$ in this figure is similar to that shown in figure 4(c). The spectrum of this sampled signal can be defined as follows (using notation similar to that developed in Appendix A)

$$x(nT) \Leftrightarrow F_- \left(f - \frac{W}{2} \pm 2mW \right) + F_+ \left(f + \frac{W}{2} \pm 2mW \right) \quad m \text{ an integer} \quad (15)$$

where \Leftrightarrow denotes the Fourier transform operation. $F_-\left(f - \frac{W}{2}\right)$ is the positive half of the spectrum of the sampled signal, and $F_+\left(f + \frac{W}{2}\right)$ is the negative half.

The in-phase and quadrature bandpass filters, $h_I(n)$ and $h_Q(n)$ respectively, are both derived from the same lowpass filter, $h_L(n)$, of bandwidth $\frac{W}{2}$, via the following frequency transformations.

$$h_I(n) = h_L(n) \cos\left(\frac{W}{2}\left(n - \frac{N-1}{2}\right)\right) \quad (16)$$

$$h_Q(n) = h_L(n) \sin\left(\frac{W}{2}\left(n - \frac{N-1}{2}\right)\right) \quad (17)$$

where N is the order of the lowpass filter $h_L(n)$.

The two bandpass filters will have identical amplitude responses but will be 90° out of phase. To simplify the analysis, assume that the lowpass filter, $h_L(n)$, has a frequency response.

$$\begin{aligned} H_L(f) &= H(f \pm mf_s) \quad m \text{ an integer} \\ &= H(f \pm 2mW) \end{aligned} \quad (18)$$

since $f_s = 2W$, and where

$$H(f) = \begin{cases} 1, & -\frac{W}{2} < f < +\frac{W}{2} \\ 0 & \text{otherwise} \end{cases} \quad (19)$$

The frequency response of the two bandpass filters will be as follows

$$H_I(f) = H\left(f - \frac{W}{2} \pm 2mW\right) + H\left(f + \frac{W}{2} \pm 2mW\right), \quad m \text{ an integer} \quad (20)$$

$$H_Q(f) = -jH\left(f - \frac{W}{2} \pm 2mW\right) + jH\left(f + \frac{W}{2} \pm 2mW\right), \quad m \text{ an integer} \quad (21)$$

Consider first $x(nT)$ being filtered by the in-phase bandpass filter $h_I(n)$. The resulting spectrum (denoted $X_{IF}(f)$ for in-phase filtered version of $x(nT)$, $x_{IF}(nT)$) will be

$$\begin{aligned}
X_{IF}(f) &= H_I(f) \times \left(F_- \left(f - \frac{W}{2} \pm 2mW \right) + F_+ \left(f + \frac{W}{2} \pm 2mW \right) \right) \\
&= H \left(f - \frac{W}{2} \pm 2mW \right) F_- \left(f - \frac{W}{2} \pm 2mW \right) \\
&\quad + H \left(f + \frac{W}{2} \pm 2mW \right) F_+ \left(f + \frac{W}{2} \pm 2mW \right) \quad (22)
\end{aligned}$$

The signal $x_{IF}(nT)$ is then decimated by a factor 2, reducing the sample rate from $2W$ to W samples/sec. This results in the portion of the spectrum that covered the range $-W < f < +W$ being replicated at intervals of W , instead of $2W$. The spectrum of the decimated signal $x_{IF}(nT')$ (where $T' = 2T$) will be

$$\begin{aligned}
x_{IF}(nT') \Leftrightarrow & H \left(f - \frac{W}{2} \pm mW \right) F_- \left(f - \frac{W}{2} \pm mW \right) \\
& + H \left(f - \frac{W}{2} \pm mW \right) F_+ \left(f - \frac{W}{2} \pm mW \right) \quad (23)
\end{aligned}$$

Note that this expression shows that

$$H \left(f - \frac{W}{2} \pm mW \right) F_- \left(f - \frac{W}{2} \pm mW \right)$$

and

$$H \left(f - \frac{W}{2} \pm mW \right) F_+ \left(f - \frac{W}{2} \pm mW \right)$$

are aliased. Finally the signal $x_{IF}(nT')$ is multiplied by $(-1)^n$, which in the frequency domain is equivalent to shifting the spectrum by $\frac{W}{2}$ (or π radians). Thus the spectrum of the signal after this operation, designated $x_I(nT')$ in figure 5, is

$$\begin{aligned}
x_I(nT') \Leftrightarrow & X_I(f) \\
X_I(f) &= H(f \pm mW) F_-(f \pm mW) + H(f \pm mW) F_+(f \pm mW) \quad (24)
\end{aligned}$$

Ignoring the spectral replication at intervals of $\pm mW$ which exists because of the nature of sampled signals, this becomes

$$X_I(f) = H(f) F_-(f) + H(f) F_+(f) \quad (25)$$

If $H(f)$ is an ideal lowpass filter of bandwidth $\frac{W}{2}$, as described in equation (19), then comparing equation (25) with equation (A-7) in Appendix A, it can be seen that $x_I(nT')$ is a sampled version of $x_I(t)$, the in-phase component of the original bandpass signal.

Following a similar argument, the spectrum of $x_{QF}(nT)$ (designated $X_{QF}(f)$) is

$$\begin{aligned} X_{QF}(f) &= H_Q(f) \times \left(F_- \left(f - \frac{W}{2} \pm 2mW \right) + F_+ \left(f + \frac{W}{2} \pm 2mW \right) \right) \\ &= -jH \left(f - \frac{W}{2} \pm 2mW \right) F_- \left(f - \frac{W}{2} \pm 2mW \right) \\ &\quad + jH \left(f + \frac{W}{2} \pm 2mW \right) F_+ \left(f + \frac{W}{2} \pm 2mW \right) \end{aligned} \quad (26)$$

$x_{QF}(nT)$ is then decimated by a factor of 2, reducing the sample rate to W samples/sec. This gives $x_{QF}(nT')$ (where $T' = 2T$) which has a spectrum as follows

$$\begin{aligned} x_{QF}(nT') \Leftrightarrow & -jH \left(f - \frac{W}{2} \pm mW \right) F_- \left(f - \frac{W}{2} \pm mW \right) \\ & + jH \left(f - \frac{W}{2} \pm mW \right) F_+ \left(f - \frac{W}{2} \pm mW \right) \end{aligned} \quad (27)$$

Finally the signal $x_{QF}(nT')$ is multiplied by $(-1)^n$ giving the signal designated as $x_Q(nT')$ in figure 5, which has the spectrum

$$\begin{aligned} x_Q(nT') \Leftrightarrow & X_Q(f) \\ X_Q(f) &= -jH(f \pm mW) F_-(f \pm mW) + jH(f \pm mW) F_+(f \pm mW) \end{aligned} \quad (28)$$

Ignoring the spectral replication at intervals of $\pm mW$, this can be written as

$$X_Q(f) = -jH(f)F_-(f) + jH(f)F_+(f) \quad (29)$$

As with the previous case, if $H(f)$ is an ideal lowpass filter of bandwidth $\frac{W}{2}$, as described in equation (19), then comparing equation (29) above with equation (A-8) in Appendix A, it can be seen that $x_Q(nT')$ is a sampled version of $x_Q(t)$, the quadrature component of the original bandpass signal.

The results shown in equations (25) and (29) show that the technique outlined in figure 5 is a valid method of obtaining sampled versions of the in-phase and quadrature components of a bandpass signal, provided that equations (13) and either (9) and (10), or (11) and (12) are satisfied. It is important to note that the same result can be achieved by removing the in-phase bandpass filter, and replacing the quadrature bandpass filter with a Hilbert transformer [4]. However the method described above gives superior matching between the quadrature channels.

4 An Efficient Data Acquisition System for Bandpass Signals

As the required product of a data acquisition system is computer-readable data, it would be highly desirable for the system to store the data directly in a computer-readable form. In the past, this has not been possible due to the high data rates involved and the limited data rate and storage capacities of computer hardware. However, computer technology has reached the point where storage capacity in excess of 1 Gbyte is available on disk drives, with sustained throughput to these devices in the order of hundreds of KBytes per second. If a sampling scheme is used where the bandpass data is sampled at a rate of twice its bandwidth, then much lower data rates will be achieved. Combining such a sampling scheme with the current generation of computer hardware will give a data acquisition system whose stored output is computer-readable, and ready for immediate analysis. An added bonus is that there are now fewer steps in the process, since the decoding step is redundant, and consequently there are cost-savings in employing this method.

Consider the technique of complex demodulation outlined in section 3.2. This technique first samples the bandpass data at a rate of twice the signal bandwidth, and then processes this sampled data further to obtain sampled versions of the in-phase and quadrature components of the bandpass signal. If this technique is used as part of a data acquisition system, then the data could be stored immediately after sampling, with the remainder of the complex demodulation process performed at some later stage. As this method uses a sample rate of twice the signal bandwidth, it can be used in an acquisition system that is computer-based and uses computer storage devices to store the results of the acquisition process. It is important to note that this sampling technique is only applicable to bandpass signals that satisfy equations (13) and either (9) and (10) or (11) and (12) (see sections 3.1 and 3.2).

A possible architecture for such a data acquisition system is shown in figure 6.

In this system, the N multi-channel data acquisition cards are connected to a computer bus (e.g. VME bus). Also connected to this bus is a controlling CPU, which has multiple disk drives and a tape drive as peripherals. The controlling CPU is running a software process that controls the data acquisition cards. As the data is captured by the cards, the CPU reads the data over the bus, and then writes the data to a file on one of the disk drives. This process continues until the disk drive in use becomes full, at which stage the file writing process begins writing to the second disk. This activity continues until all the disk capacity has been utilised. At this point, data acquisition will cease, and another software process will run on the CPU to copy all the data files from the disk drives to the tape drive. Once the transfer to tape has been completed, the files on the disk can be deleted, freeing up disk space so that the data acquisition process can start again. Details of how this type of data acquisition system could be applied to the AN/SQS-56 sonar is given in Appendix D.

Currently, the largest storage capacity available with SCSI¹ disk drives is 2.9 Gbytes. The current generation of workstations typically support up to 4 disk drives, giving

¹SCSI - Small Computer Systems Interface

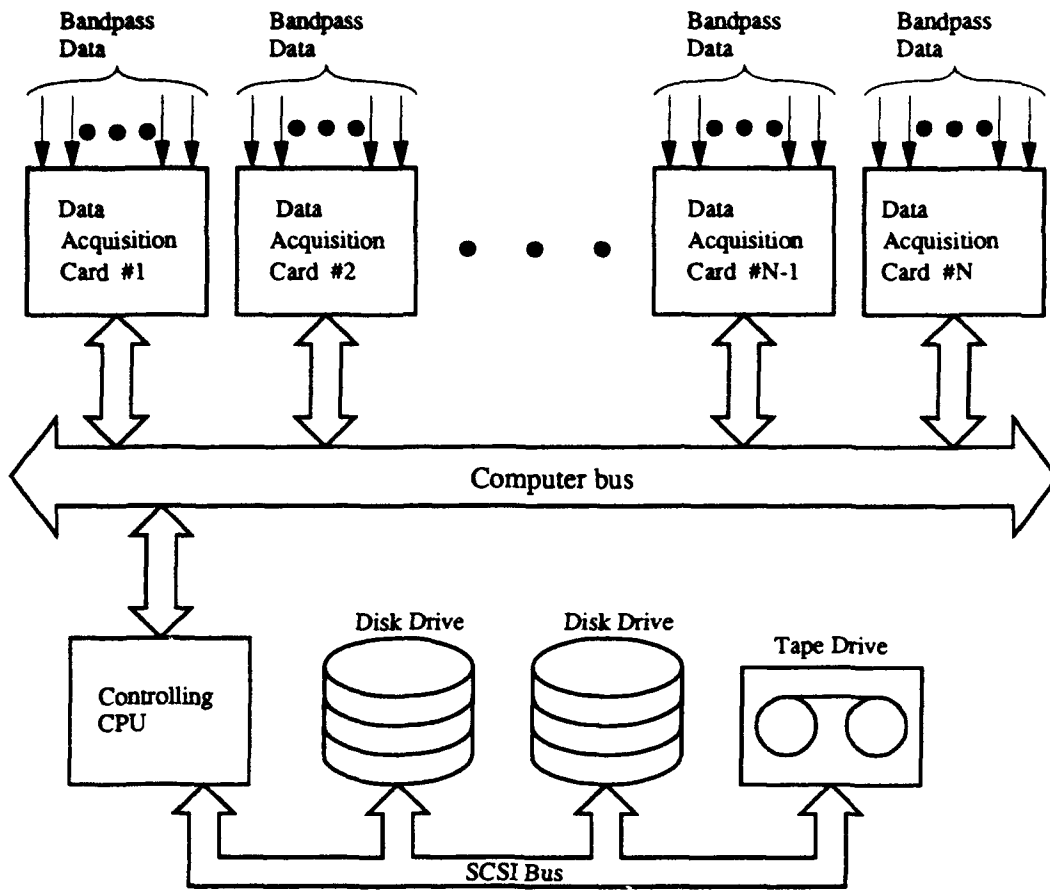

Figure 6: Functional block diagram of a computer-based data acquisition system

a total possible storage capacity of 11.6 Gbytes (if such a computer was used as the host CPU). This would provide sufficient storage capacity for more than 3 hours of data at a data rate of 1 Mbyte/second, and more than 12 hours at a data rate of 250 Kbytes/second. However, achieving a sustained transfer rate of 1 Mbyte/second in this type of situation is unlikely due to the other tasks being performed by the CPU. A more realistically achievable data rate would be around 400- 500 Kbytes/second sustained.

At present, computer tape drives have not reached the point where their sustained transfer rate is high enough to make them usable as the primary storage device for a computer-based acquisition system. As technology improves, this situation may change, enabling a system to use multiple tape drives as the primary storage device. Continuous storage capability would then be achieved by changing tapes in one drive while the other is in use.

An acquisition system of this type would be very flexible, as the whole process is under software control. It would simply be a matter of re-configuring the software to cope with different sampling rates, number of channels etc. This type of system can only

be used where the overall data rate is less than the sustained throughput achievable with current computer disk drives. As such, it provides an effective solution to data acquisition problems where there is a large number of bandpass signals that can be sampled at a rate of twice their bandwidth. A data acquisition system similar to this is being developed for the AN/SQS 56 sonar, and is described in Appendix D

5 Summary

An overview of bandpass signals, and special techniques for sampling bandpass signals has been presented. These sampling techniques provide an efficient method of sampling bandpass signals without loss of information. In particular, a method that applies to a special class of bandpass signals has been described that enables a bandpass signal to be sampled directly at a rate of twice its bandwidth. The quadrature representation of the bandpass signal can be extracted from the sampled data, giving a different method of complex demodulation than that normally used.

By using this method of complex demodulation, the data can be stored immediately after sampling. The lower data rate achieved using this sampling method enables computer disk drives to be used for storage in place of the large magnetic tapes normally used. Being computer based, the data acquisition system uses computer storage media, which offer a number of advantages over a tape based system. Magnetic tape based systems typically use special encoders when recording, requiring the tapes to be replayed through decoders to obtain the data in a usable form. In contrast, the method described in this report is more efficient, providing the data in an immediately usable form. The result is savings in equipment, work effort, time, and hence cost.

Another advantage of this type of system is its flexibility. It is easily changed to suit different data acquisition problems (fewer channels at a higher data rate, or more at a lower rate) by re-configuring the software. The system is also easily upgradable, enabling the capacity of the system to be increased as faster and larger capacity disk drives become available. A data acquisition system of this type, making use of the concepts presented in this report, is being developed for the AN/SQS-56 sonar.

References

- [1] D. A. Linden, A Discussion of Sampling Theorems, *Proceedings of the IRE*, July 1959.
- [2] O. D. Grace and S. P. Pitt, Sampling and Interpolation of Bandlimited Signals by Quadrature Methods, *Journal of the Acoustical Society of America*, Vol. 48, No. 6 (Pt 1), 1970.
- [3] J. L. Brown, On Quadrature Sampling of Bandpass Signals, *IEEE Trans. Aerospace and Electronic Systems*, Vol. AES-15, No. 3, May 1979.
- [4] D. W. Rice and K. H. Wu, Quadrature Sampling with High Dynamic Range, *IEEE Trans. Aerospace and Electronic Systems*, Vol. AES-18, No. 4, November 1982.
- [5] C. M. Rader, A Simple Method for Sampling In-Phase and Quadrature Components, *IEEE Trans. Aerospace and Electronic Systems*, Vol. AES-20, No. 6, November 1984.
- [6] R. G. Pridham and R. A. Mucci, Digital Interpolation Beamforming for Low-Pass and Bandpass Signals, *Proc. IEEE*, Vol. 67, No. 6, June 1979.
- [7] W. C. Knight, R. G. Pridham and S. M. Kay, Digital Signal Processing for Sonar, *Proc. IEEE*, Vol. 69, No. 11, November 1981.
- [8] Interactive Circuits and Systems Ltd., DAS/SCD-256 Complete Data Acquisition System - Product Description, Interactive Circuits and Systems Ltd.
- [9] D. Roy and P. Ménard, Data Acquisition and DSP Using the ICS-100, INPUT, Technical Reporting from ICS, No. 3, Interactive Circuits and Systems Ltd, May 1987.

A Complex Demodulation

A.1 Spectrum of a complex demodulated signal

Let $x(t)$ be a bandpass signal, with centre frequency f_o , bandwidth W , and spectrum $X(f)$.

$$x(t) = x_I(t) \cos(2\pi f_o t) - x_Q(t) \sin(2\pi f_o t) \quad (\text{A-1})$$

where $x_I(t)$ and $x_Q(t)$ are obtained as follows

$$x_I(t) = 2 \cos(2\pi f_o t) x(t) \Big|_{LP} \quad (\text{A-2})$$

$$x_Q(t) = 2 \sin(2\pi f_o t) x(t) \Big|_{LP} \quad (\text{A-3})$$

where $|_{LP}$ denotes a lowpass filtering operation.

Define $F_+(f - f_o)$ and $F_-(f + f_o)$ to be the positive and negative halves of the spectrum of the bandpass signal $x(t)$ respectively. Let \Leftrightarrow denote the Fourier transform operation, then

$$\begin{aligned} x(t) &\Leftrightarrow X(f) \\ X(f) &= F_+(f - f_o) + F_-(f + f_o) \end{aligned} \quad (\text{A-4})$$

Also

$$2 \cos(2\pi f_o t) \Leftrightarrow \delta(f - f_o) + \delta(f + f_o) \quad (\text{A-5})$$

$$2 \sin(2\pi f_o t) \Leftrightarrow j\delta(f - f_o) + j\delta(f + f_o) \quad (\text{A-6})$$

The spectrum of the in-phase signal $x_I(t)$ is given by the convolution of (A-4) and (A-5), followed by a lowpass filter, as shown by (A-7) below

$$\begin{aligned} X_I(f) &= X(f) * [\delta(f - f_o) + \delta(f + f_o)] \Big|_{LP} \\ &= [F_+(f - f_o) + F_-(f + f_o)] * [\delta(f - f_o) + \delta(f + f_o)] \Big|_{LP} \\ &= F_+(f - 2f_o) + F_+(f) + F_-(f) + F_-(f + 2f_o) \Big|_{LP} \\ &= F_+(f) + F_-(f) \end{aligned} \quad (\text{A-7})$$

The spectrum of the quadrature signal $x_Q(t)$ is given by the convolution of (A-4) and (A-6), followed by a lowpass filter. The result is given by (A-8) below.

$$\begin{aligned} X_Q(f) &= X(f) * [j\delta(f - f_o) + j\delta(f + f_o)] \Big|_{LP} \\ &= [F_+(f - f_o) + F_-(f + f_o)] * [j\delta(f - f_o) + j\delta(f + f_o)] \Big|_{LP} \\ &= -jF_+(f - 2f_o) + jF_+(f) - jF_-(f) + jF_-(f + 2f_o) \Big|_{LP} \\ &= jF_+(f) - jF_-(f) \end{aligned} \quad (A-8)$$

B Overview of Quadrature Beamforming

B.1 Review of the Conventional Digital Beamformer Structure

Consider the conventional digital beamformer shown in figure B-1.

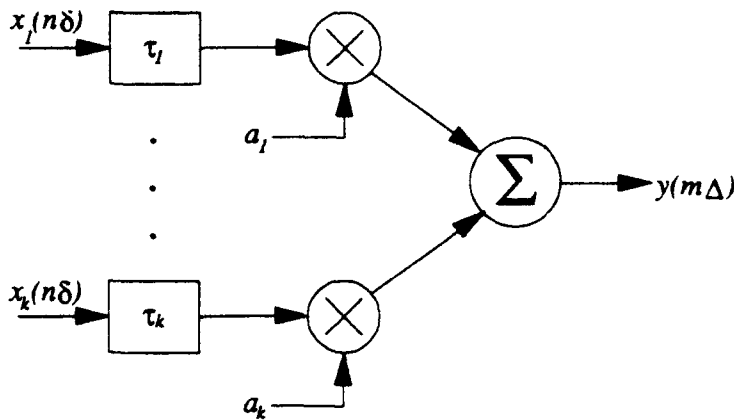

Figure B-1: Conventional Time Domain Delay-Sum Digital Beamformer

In this type of structure, the sampling interval δ ($= \frac{1}{f_s}$) is sufficiently small to achieve the delay quantisation required for beam steering. The sampling interval to satisfy the Nyquist criterion is Δ ($= \frac{1}{f_\Delta}$), which is often an integer multiple of δ (this is not a general requirement however). i.e.

$$\Delta = L\delta, \quad \text{where } L = 1, 2, 3, 4, \dots \quad (\text{B-1})$$

Referring to figure B-1 for simplicity, assume that the beam output y is produced at a sample rate of Δ , which is sufficient for waveform reconstruction. Note that the beam output can be computed at a rate $K\delta$, where K is an integer not equal to L . For the former case, the beam output $y(m\Delta)$ is found from the weighted sum of delayed versions of the k input sequences. The delays for each sensor input are an integer multiple of the sampling interval δ , i.e.

$$\tau_i = M_i\delta \quad (\text{B-2})$$

where M_i is an integer such that the product $M_i\delta$ gives the closest approximation to the exact delay required for the desired beam steering angle. For the case where the beam output rate is an integer sub-multiple of the input data rate, the beamformed output is given by equation (B-3)

$$\begin{aligned}
y(m\Delta) &= \sum_{i=1}^k a_i x_i(m\Delta - \tau_i) \\
&= \sum_{i=1}^k a_i x_i((mL - M_i)\delta)
\end{aligned} \tag{B-3}$$

where a_i denotes the weighting or shading applied to each input sequence. The total input data rate for this structure is kf_δ , and the output data rate per beam is f_Δ . Implementation of equation B-3 requires real additions at a rate of $(k - 1)f_\Delta$ and real multiplications at a rate of kf_Δ per beam.

This type of beamforming structure requires high input data rates, increasing the complexity of the hardware required. Interpolation beamformers [2] result in reduced hardware complexity, but increase the computational complexity. However for bandpass signals, even interpolation beamformers use sampling rates that are consistent with the highest frequency of interest, rather than consistent with the bandwidth of bandpass signal. The following section describes a different beamformer structure that can be used for bandpass signals.

B.2 The Quadrature Beamformer Structure

The representation of a bandpass signal in terms of sampled versions of the in-phase and quadrature components is an efficient means (in terms of data rate) of characterising the signal. A quadrature beamformer is a beam forming structure that operates on this efficient representation of a bandpass signal, producing beam outputs that are discrete-time versions of the in-phase and quadrature components of the beamformed signal.

If the beamformer inputs $x_i(n\delta)$ are bandpass centred on frequency f_o , the beamformed output $y(m\Delta)$ will also be bandpass centred on frequency f_o . $y(m\Delta)$ can be expressed in terms of its in-phase and quadrature components, $y_I(m\Delta)$ and $y_Q(m\Delta)$, as shown by equation (B-4)

$$y(m\Delta) = y_I(m\Delta) \cos(2\pi f_o m\Delta) - y_Q(m\Delta) \sin(2\pi f_o m\Delta) \tag{B-4}$$

If equation (B-3) is re-written so that the sensor inputs are expressed in terms of their in-phase and quadrature components, i.e.

$$\begin{aligned}
y(m\Delta) &= \sum_{i=1}^k a_i \left[x_{I_i}(m\Delta - \tau_i) \cos(2\pi f_o(m\Delta - \tau_i)) \right. \\
&\quad \left. - x_{Q_i}(m\Delta - \tau_i) \sin(2\pi f_o(m\Delta - \tau_i)) \right] \\
&= \sum_{i=1}^k a_i \left[x_{I_i}(m\Delta - \tau_i) \cos(2\pi f_o m\Delta) \cos(2\pi f_o \tau_i) \right. \\
&\quad + x_{I_i}(m\Delta - \tau_i) \sin(2\pi f_o m\Delta) \sin(2\pi f_o \tau_i) \\
&\quad - x_{Q_i}(m\Delta - \tau_i) \sin(2\pi f_o m\Delta) \cos(2\pi f_o \tau_i) \\
&\quad \left. + x_{Q_i}(m\Delta - \tau_i) \cos(2\pi f_o m\Delta) \sin(2\pi f_o \tau_i) \right] \tag{B-5}
\end{aligned}$$

then equating equations (B-4) and (B-5) give

$$y_I(m\Delta) = \sum_{i=1}^k a_i \left[x_{I_i}(m\Delta - \tau_i) \cos(2\pi f_o \tau_i) + x_{Q_i}(m\Delta - \tau_i) \sin(2\pi f_o \tau_i) \right] \tag{B-6}$$

and

$$y_Q(m\Delta) = \sum_{i=1}^k a_i \left[x_{Q_i}(m\Delta - \tau_i) \cos(2\pi f_o \tau_i) - x_{I_i}(m\Delta - \tau_i) \sin(2\pi f_o \tau_i) \right] \tag{B-7}$$

Equations (B-6) and (B-7) show that the in-phase and quadrature components of the beam output can be obtained from the in-phase and quadrature components of the sensor data.

It is important to note that for an original spectral bandwidth of W , both y_I and y_Q are base band signals of bandwidth $\frac{W}{2}$. Consequently, the sample spacing required to adequately represent y_I and y_Q is $\Delta = W^{-1}$, rather than $\Delta = \left(2\left(f_o + \frac{W}{2}\right)\right)^{-1}$, (here f_o is the centre frequency of the bandpass signal as before), which is the case for the beam output y .

Hence for equations (B-6) and (B-7), the sample spacing Δ is given by equation (B-8)

$$\Delta = \frac{1}{W} \tag{B-8}$$

As before, the delays τ_i required for beam steering are approximated by $M_i \delta$, where $\delta < \Delta$. However because the in-phase and quadrature components of the sensor data are less rapidly varying functions of time than the sensor data itself (lowpass instead of bandpass), they can be aligned more coarsely in time prior to beamforming. The sampling interval δ required for beamforming needs to be such that the quadrature input data can be aligned to a fraction of its highest wavelength ($\frac{W}{2}$). Thus δ depends on W rather than $f_o + \frac{W}{2}$. Reference [3] gives a comparison of this type of approach

with a conventional beamformer, showing the effect of phase errors introduced by the coarser delay quantisation.

The information regarding the carrier frequency f_0 is contained in the sine/cosine shading coefficients that weight the in-phase and quadrature components of the sensor data prior to beamforming. The delay τ_i in these coefficients must be specified accurately, but this does not affect Δ or δ .

As the in-phase and quadrature components of the sensor data are both lowpass of bandwidth $\frac{W}{2}$, they can be adequately represented with a sample spacing of Δ given by equation (B-8), with the vernier delays δ required for beam forming obtained by interpolation [1], [2]. This results in both the input and output data rates being reduced to the minimum allowed, but at the expense of increased computation. For an interpolation beamformer, the interpolation can be carried out either before or after the beamforming operation. Figure B-2 shows a quadrature beamformer with the interpolation performed prior to the beamforming.

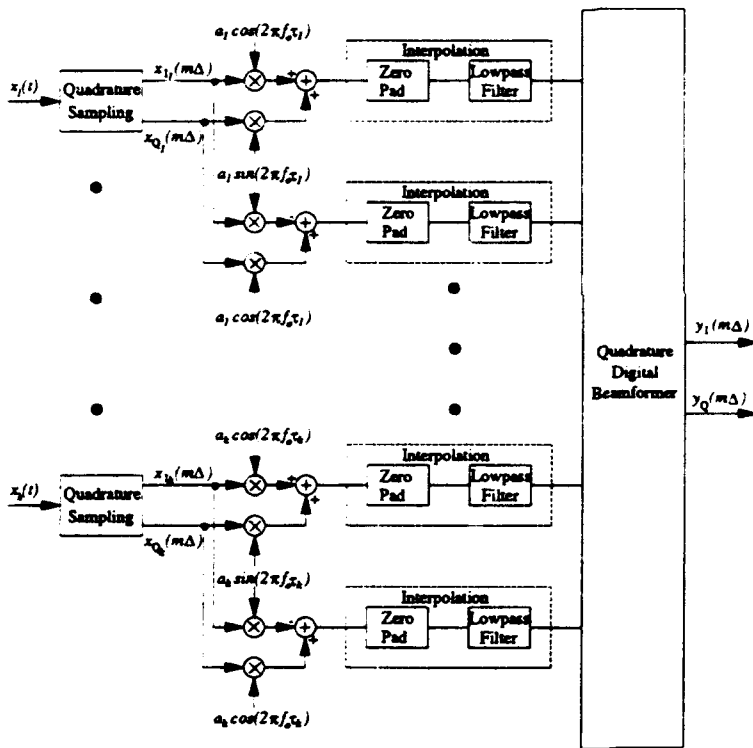

Figure B-2: Quadrature beamformer with Pre-beamforming interpolation

References

- [1] R. G. Pridham and R. A. Mucci, Digital Interpolation Beamforming for Low-Pass and Bandpass Signals, *Proc. IEEE*, Vol. 67, No. 6, June 1979.

- [2] R. G. Pridham, R. A. Mucci, A Novel Approach to Digital Beamforming, *Journal of the Acoustical Society of America*, Vol. 63 (Pt 2), February 1978.
- [3] R. G. Pridham, R. A. Mucci Shifted Sideband Beamformer, *IEEE Trans. Acoustics, Speech and Signal Processing*, Vol. ASSP-27, No. 6, December 1979.

C The AN/SQS-56 Sonar System

C.1 Overview

The AN/SQS-56 sonar system is a member of the DE1160 series of surface ship sonars developed by Raytheon. It is a hull mounted sonar that can operate in both active and passive modes, with capabilities for detection, classification, localisation and tracking. When operating in the active mode, it forms 36 equi-spaced beams covering the full 360° arc around the ship.

The sonar set comprises the following subsystems:

- Transducer Array Subsystem which provides the conversion between electrical and acoustic energy and the physical interface between the system and the medium.
- Array Interface Subsystem which provides aperture orders to the transducer and pre-amplifies the active and passive signals from the transducer.
- Transmitter Subsystem which provides the transmitted power in the required phase and amplitude.
- Receiver Subsystem which forms the received active and passive inputs into the required beams, suitably processes these signals and delivers digital active and passive video, as well as audio, to the console.
- Controller Subsystem whose integral general purpose computer controls the functioning of the system in response to stimuli provided by the operator console. It also distributes system power, and provides interface to certain other ship systems.
- Control Indicator Subsystem which displays the processed received signals and the formatted status and operation data, and provides the interface between the operator and the system (i.e the console).
- Fault Detection and Fault Location Subsystem which automatically detects and reports, on line, system faults to the operator at the console, automatically provides indications of possible faults by audible and visible alarms and localizes these to limited areas of the system.

A functional block diagram showing these subsystems (except for the Fault Detection and Fault Location subsystem, which is integrated within the other subsystems) and their major inter-connections is shown in Figure C-1.

As the intended application of the type of data acquisition system described in this report is to the active data stream of the AN/SQS-56 sonar, only details relevant to the active mode of operation will be considered. When operating in the active mode, the sonar transmits on one of three nominal centre frequencies, 6.7, 7.5 and 8.4 kHz, with a bandwidth of 600 Hz. Further details of the operation of the sonar set can be found in [1] - [2].

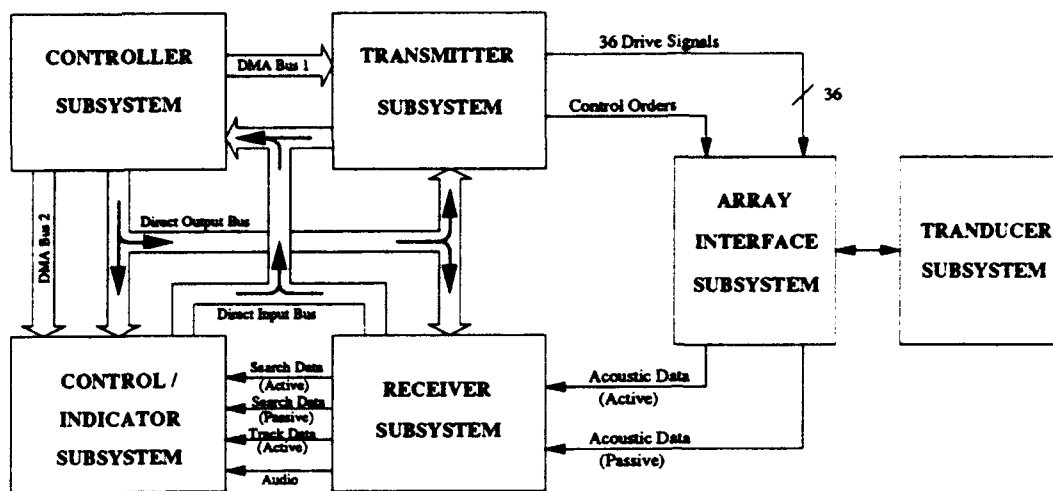

Figure C-1: AN/SQS-56 Sonar - Functional block diagram

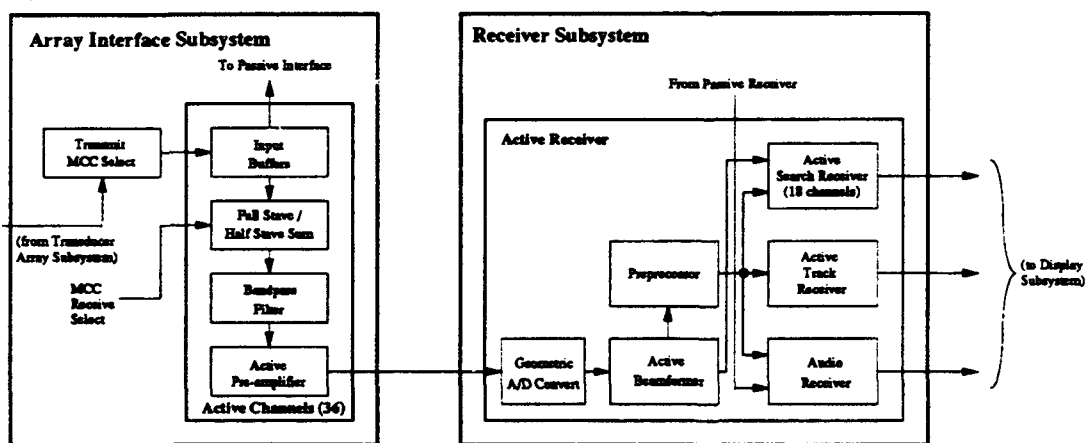

Figure C-2: Functional block diagram of Array Interface and Receiver Subsystems

Consider the functional block diagram of the Array Interface and Receiver Subsystems shown in figure C-2.

This diagram shows that the active receive signals from the hydrophones which make up the transducer array are first buffered, then summed to give a single signal per stave. The stave sums are then passed through a bandpass filter (whose centre frequency matches the selected transmit frequency), followed by a pre-amplifier/buffer, before passing through isolation transformers. The balanced outputs from the isolation transformers pass from the array interface subsystem to the receiver subsystems via a connecting cable, where they are converted to digital signals using a geometric analog to digital converter. These digital signals are then beamformed via a digital beamformer before undergoing further processing.

The output of the beamformer would seem the logical place from which to extract and record the data. However, to allow a wider range of processing options to be explored when the data is processed, a better place from which to extract and record the data is prior to beamforming. Given this, the best place for the data to be extracted is at the connection between the array interface and receiver subsystems (i.e. after the active pre-amplifier and before the geometric A/D converter).

Table C-1 gives the characteristics of the signal conditioning electronics through which the active data signals pass within the array interface unit. Further information can be found in [1] - [2].

Characteristic	Value	Unit	Remarks
Voltage Gain	45.8/37.1	dB	Coherent/incoherent gain/8 equal elements referenced to element input
Bandwidth	600	Hz	Measured at 3 dB down points, center frequencies of $f_1 = 6.7$, $f_2 = 7.5$, $f_3 = 8.4$ kHz. Filters shall not be less than 50 dB down at $f_x \pm 600$ Hz.
Dynamic Range	90	dB	Input base reference level = -135dBV, 1-Hz band
Output Voltage	+15	dBV	< 2% distortion into 1 K ohm paralleled with 1200 pF, 6 - 9 kHz

Table C-1: Active Pre-amplifier Characteristics

From this table and [1], it can be seen that the 36 active signals which connect the array interface to the active receiver have the following characteristics

- bandpass, centred at f_{tx} of either 6, 7, 7.5, or 8, 4 kHz, with 3 dB points at $f_{tx} \pm 300$ Hz.
- signals are ≥ 50 dB down at $f_{tx} \pm 600$ Hz
- transformer isolated, providing balanced signals
- maximum signal level is at +15 dB re 1 V rms

As these signals at the desired acquisition point are bandpass in nature, it is possible to use a bandpass sampling technique rather than conventional sampling techniques, resulting in a lower overall data rate and a reduction in storage requirements.

References

- [1] Raytheon Company, Sonar Set AN/SQS-56 Technical Manual, Vol. 1 - 21, Submarine Signal Division, Raytheon Company.
- [2] Raytheon Company, DE1160C Sonar System Specification (P1543), Submarine Signal Division, Raytheon Company, July 1976.

D Data Acquisition for the AN/SQS-56 Sonar

D.1 Proposed Sampling Method for Active Data Stream

In Appendix C, the point identified as being most suitable for acquiring the data was between the array interface and receiver subsystems. However at this point, the 36 active signals are the transducer stave sums. Hence the sampling method used must be such that these signals can be passed through a digital beamformer to form 36 beams corresponding to the 36 beams formed internally within the receiver.

As the signals at the identified "pick off" point are bandpass in nature, the technique of integer band shifting on sampling (as detailed in section 3.1) can be used to sample the signals, providing the conditions outlined in section 3.1 are satisfied. If this is possible, the method of complex demodulation detailed in section 3.2 can be used to convert these sampled signals to sampled representations of the in-phase and quadrature components of the "stave sum" signals. These quadrature signals can then be processed by a quadrature beamformer to form the 36 beams required to emulate the 36 active beams used by the sonar set. An outline of quadrature beamforming is given in Appendix B.

Consider first the case where the sonar is operating on its highest frequency, $f_{tx} = 8.4$ kHz. The stave sum signals are at least 50 dB down at 8.4 ± 0.6 kHz. Assuming a minimum signal to noise ratio of 50 dB for further processing, the minimum signal bandwidth that can be tolerated for sampling will be 1200 Hz ($f_L = 7.8$ and $f_U = 9.0$ kHz), requiring a minimum sample rate of at least twice this. As the upper and lower frequency bounds f_U and f_L actually denote the stop band edges, equation (14) of section 3.1 applies. If W denotes the signal bandwidth, f_L , f_U and f_s can be written as follows

$$f_L = f_{tx} - \frac{W}{2} \quad (D-1)$$

$$f_U = f_{tx} + \frac{W}{2} \quad (D-2)$$

$$f_s = 2W \quad (D-3)$$

If equation (D-3) is re-written to express W in terms of f_s , and then substituted into equation (D-2), which is then substituted into equation (12) of section 3.1, an expression for f_s in terms of k and f_{tx} is obtained.

$$f_s = \frac{f_{tx}}{k - \frac{1}{4}} \quad \text{where } k = 1, 2, 3, 4, \dots \quad (D-4)$$

Table D-1 shows f_s , f_L , f_U and W for various values of k

It was mentioned above that the minimum bandwidth which provides adequate attenuation for out of band signals is 1200 Hz, and so only the first 3 solutions given in table D-1

k	Sampling Frequency, f_s (Hz)	Lower Frequency Bound, f_L (Hz)	Upper Frequency Bound, f_U (Hz)	Bandwidth W (Hz)
1	11200	5600	11200	5600
2	4800	7200	9600	2400
3	3055	7636	9164	1527
4	2240	7840	8960	1120

Table D-1: Possible sampling frequencies for integer band shifting, $f_{ix} = 8400$ Hz

apply, with the third solution providing the best compromise in terms of data rate and out of band attenuation.

Similar tables for the two other transmission frequencies of 6.7 and 7.5 kHz are shown in tables D-2 and D-3. The figures given in these tables were evaluated using similar method to that used for table D-1

k	Sampling Frequency, f_s (Hz)	Lower Frequency Bound, f_L (Hz)	Upper Frequency Bound, f_U (Hz)	Bandwidth W (Hz)
1	8933	4467	8933	4467
2	3828	5743	7657	1914
3	2436	6091	7309	1218
4	1787	6253	7147	893

Table D-2: Possible sampling frequencies for integer band shifting, $f_{ix} = 6700$ Hz

k	Sampling Frequency, f_s (Hz)	Lower Frequency Bound, f_L (Hz)	Upper Frequency Bound, f_U (Hz)	Bandwidth W (Hz)
1	10000	5000	10000	5000
2	4285	6429	8571	2143
3	2727	6818	8182	1364
4	2000	7000	8000	1000

Table D-3: Possible sampling frequencies for integer band shifting, $f_{ix} = 7500$ Hz

For the cases outlined in tables D-2 and D-3, only the first 3 solutions satisfy the minimum bandwidth requirement, with the third solution giving the lowest sampling frequency.

Note that tables D-1 to D-3 are for the case where $f_s = kf_U$. A similar set of tables for the other case of $f_s = kf_L$ can be obtained by expressing f_s as a function of f_{ix} and k , and working through the numbers (an expression is obtained similar to the method for equation (D-4), except equation (9) from section 3.1 is used in place of equation (12) in the substitution). This option would also require the method outlined in section 3.2 to be modified to obtain the in-phase and quadrature signals as outputs.

These tables show that for each of the 3 transmit frequencies, integer band shifting on sampling is possible without any unintentional aliasing. This means that the method of complex demodulation described in section 3.1 is applicable to the active data signals, resulting in a much lower overall data rate than would be possible using conventional sampling techniques. For all three transmit frequencies, the higher sampling frequency will give the best signal to noise ratio (maximum out-of-band attenuation, thus minimizing objectionable aliasing), but result in higher data rates. The final sampling rate used will be the highest rate the data acquisition system can cope with.

D.2 Data Acquisition System Proposal

The overall function of the data acquisition system is to digitize the active data from the sonar and store it for subsequent analysis. Because of the nature of the bandpass active signals on the AN/SQS-56 sonar, it is possible to sample the signals at a rate of twice their bandwidth, as described in Appendix D.1. This sampling method results in data rates of the order of several hundred Kbytes per second for all 36 active data signals. Combining this sampling method with the type of system architecture described in section 4 will give a data acquisition system whose stored output is computer-readable, and ready for immediate analysis.

The functional requirements of a data acquisition system for the AN/SQS-56 sonar capable of the above are briefly as follows

- minimum of 12 bits per sample (preferably 16 bits)
- synchronously acquire data for all 36 data channels at a rate sufficient for beam-forming
- store several hours of acquired data
- data to be stored in computer-readable form, ready for immediate analysis
- either store the data as one data file per ping or maintain a time log of the pings so that the data can be separated on a per ping basis at some later stage.

A system consisting of the following components would be able to satisfy these requirements.

- 5 ICS-140-8A 8 channel VMEbus- based data acquisition cards
- 1 SPARC 1E² VMEbus CPU card running VxWorks³ operating system software
- 1 SPARCstation⁴

²SPARC is a registered trademark of SPARC International, Inc.

³VxWorks is a trademark of Wind River Systems, Inc.

⁴SPARCstation is a registered trademark of SPARC International, Inc., licensed exclusively to Sun Microsystems, Inc.

- 1 or more large capacity SCSI disk drive (> 1.2 Gbytes)
- 8mm (Exabyte⁵) tape drive

A functional diagram showing how these components inter-connect to form the data acquisition system is given in figure D-1.

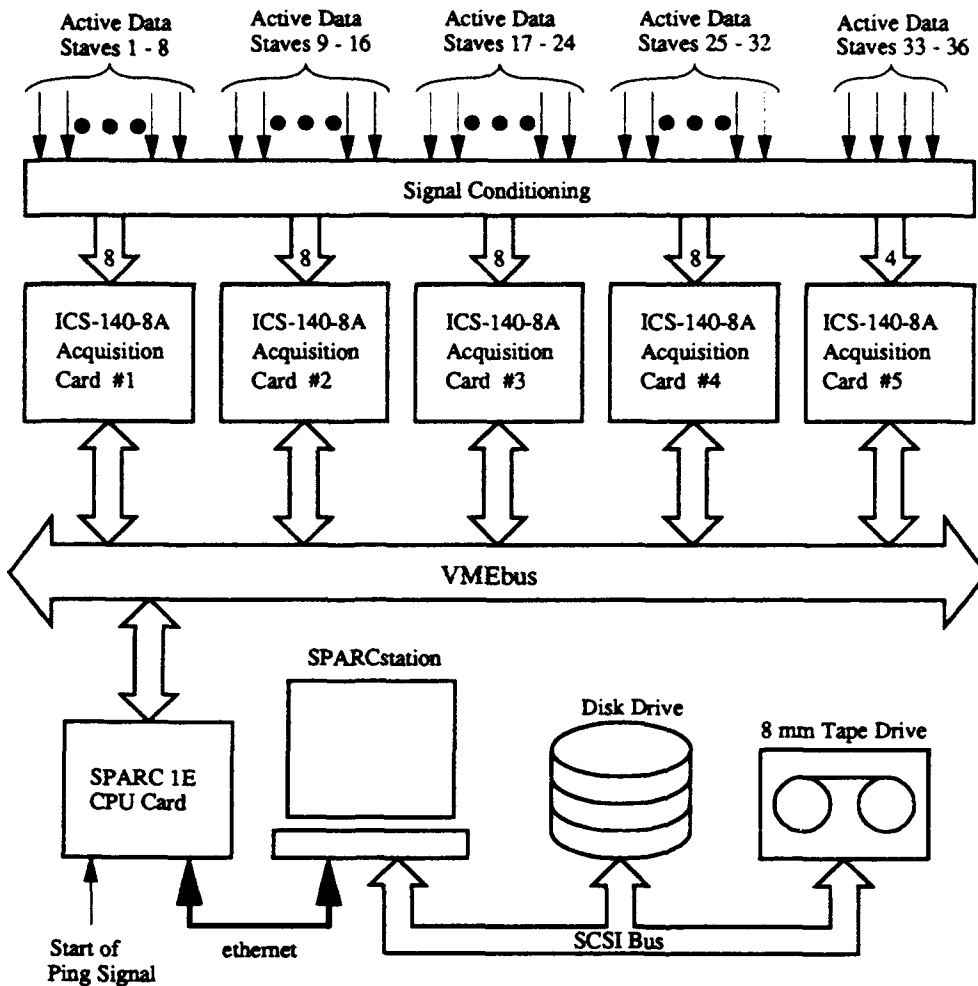

Figure D-1: Proposed SQS-56 Data Acquisition System

The 5 ICS-140-8A data acquisition cards and the SPARC 1E CPU card are housed in a single VME chassis. An ethernet cable connects the SPARC 1E CPU to the SPARCstation, which has a large capacity disk drive and 8mm tape drive as storage peripherals. The SPARC 1E will be running VxWorks software, a real time UNIX⁶-compatible operating system, while the SPARCstation will be running standard SunOS⁷.

⁵Exabyte is a registered trademark of EXABYTE Corporation

⁶UNIX is a registered trademark of AT&T Bell Laboratories

⁷SunOS is a trademark of Sun Microsystems Inc

The 36 stave sum signals are extracted from the interconnection between the array interface and receiver subsystems, and then passed through some simple signal conditioning electronics. This signal conditioning is mainly to attenuate the stave sum signals so that the signal level is compatible with the analog inputs on the ICS-140-8A data acquisition cards. Following this, the 36 "conditioned" signals are connected to 36 of the 40 analog inputs on the ICS-140-8A cards (all 8 inputs on the first 4 cards will be used, and only 4 on the fifth card).

The SPARC 1E CPU will be running VxWorks, under which will be running a number of software processes to control the operation of the ICS cards and the data acquisition process itself. Prior to any acquisition taking place, each card will be configured ready for acquisition. Once configured, the acquisition process can be started at any time. The process that controls the data acquisition, reads the data acquired by the ICS boards over the VME bus, and then writes this data to a disk file on the SPARCstation via the ethernet connection. When a start of ping signal is received by this process, the current data file is closed and a new one opened. Thus there will be a unique data file for each ping, containing all the data samples from all 36 transducer staves for that ping.

At the end of the trial period, all the data files stored on the hard disk on the SPARCstation (several hundred to approximately a thousand files). will be copied from the disk to the 8 mm tape drive for storage. Once the copying to tape has been completed, the files can be deleted to free up disk space in preparation for the next trial. As the data files stored on the tapes were originally written by a VxWorks process they will be UNIX files and thus will be computer-readable requiring no further processing before being analysed.

As the whole acquisition and storage process will be under software control, it will be a simple task to select the appropriate sampling frequency (given in tables D-1 - D-3) depending on the current transmit frequency. This flexibility together with the data storage method used makes a system such as that outlined above an ideal solution for acquiring and storing the active data stream from the AN/SQS-56 sonar.

D.3 Acquisition and Storage of Ancillary Ship Data

To enable any analysis carried out on the recorded trials data to be interpreted correctly, knowledge is required of the ships behaviour throughout the period of the trial (i.e. speed, heading, roll etc). This information is available on the ship from the Naval Combat Data System (NCDS). A system that can decode the information recorded by the NCDS is already available. This system extracts information from the NCDS recordings and stores it on a floppy disk ready for analysis at some later stage. To use this system all that would be required is to synchronise the times stored by the NCDS with those times stored by the data acquisition equipment. This would enable the ship's behaviour during each individual ping to be known accurately.

SECURITY CLASSIFICATION OF THIS PAGE

UNCLASSIFIED

REPORT NO.
MRL-TN-647

AR NO.
AR-008-300

REPORT SECURITY CLASSIFICATION
Unclassified

TITLE

An efficient data acquisition methodology for bandpass sonar signals

AUTHOR(S)
T.R. Jackson

CORPORATE AUTHOR
DSTO Materials Research Laboratory
PO Box 50
Ascot Vale Victoria 3032

REPORT DATE
November, 1993

TASK NO.
NAV 92/401

SPONSOR
RAN

FILE NO.
G6/4/8-4395

REFERENCES
9

PAGES
36

CLASSIFICATION/LIMITATION REVIEW DATE

CLASSIFICATION/RELEASE AUTHORITY
Chief, Maritime Operations Division

SECONDARY DISTRIBUTION

Approved for public release

ANNOUNCEMENT

Announcement of this report is unlimited

KEYWORDS

Bandpass signals
Beam forming

AN SQS 56 sonar

Active sonar

ABSTRACT

The function of a data acquisition system is to digitise data from a number of separate channels, and store these samples for later analysis. Sonar systems are typically multi-channel, and the associated data acquisition systems are required to handle data at high data rates. The high data rates involved in digitising bandpass sonar data usually mean that the only viable storage methods available are large magnetic tapes, with data recorded on high-speed tape recorders. One of several disadvantages of this type of storage method is that the types have to be replayed through special decoders to obtain the data in a form ready for analysis. This is a time consuming process, delaying the analysis and interpretation of the data. An alternative method of sampling bandpass sensor data which results in a much lower data rate is presented in this report. The resulting lower data rate allows advantage to be taken of the recent improvements in computer storage technology, enabling a data acquisition system to be constructed that is computer-based, and utilises computer storage devices as its primary storage media. The advantage of this storage method is that the data is in computer readable form, ready for immediate analysis. This work was carried out in support of Navy Task NAV 92/401 and an application of the theory of the AN/SQS 56 sonar is presented in the Appendices.

SECURITY CLASSIFICATION OF THIS PAGE
UNCLASSIFIED

An Efficient Data Acquisition Methodology for Bandpass Sonar Signals

T.R. Jackson

(MRL-TN-647)

DISTRIBUTION LIST

Director, MRL - title page only
Chief, Maritime Operations Division
Research Leader, Sonar Technology and Processing, MOD Salisbury
Mr T.R. Jackson
MRL Information Services

Chief Defence Scientist (for CDS, FASSP, ASSCM) 1 copy only
Director (for Library), Aeronautical Research Laboratory
Head, Information Centre, Defence Intelligence Organisation
OIC Technical Reports Centre, Defence Central Library
Officer in Charge, Document Exchange Centre 8 copies
Army Scientific Adviser, Russell Offices - data sheet only
Air Force Scientific Adviser, Russell Offices
Navy Scientific Adviser - data sheet only
Scientific Adviser, Defence Central
Director General Force Development (Land) - data sheet only
Director General Force Development (Sea)
Senior Librarian, Main Library DSTOS
Librarian - MRL Sydney 5 copies
Librarian, H Block
Librarian, Australian Defence Force Academy
Serials Section (M List), Deakin University Library, Deakin University, Geelong 3217
NAPOC QWG Engineer NBCD c/- DENGRS-A, HQ Engineer Centre, Liverpool
Military Area, NSW 2174
ABCA, Russell Offices, Canberra ACT 2600 4 copies
DASD, APW2-1-OA2, Anzac Park West, Canberra ACT - data sheet only
SO (Science), HQ 1 Division, Milpo, Enoggera, Qld 4057 - data sheet only
Counsellor, Defence Science, Embassy of Australia - data sheet only
Counsellor, Defence Science, Australian High Commission - data sheet only
Scientific Adviser to DSTC Malaysia, c/- Defence Adviser - data sheet only
Scientific Adviser to MRDC Thailand, c/- Defence Attache - data sheet only
Head of Staff, British Defence Research and Supply Staff (Australia)
NASA Senior Scientific Representative in Australia
INSPEC: Acquisitions Section Institution of Electrical Engineers
Head Librarian, Australian Nuclear Science and Technology Organisation
Senior Librarian, Hargrave Library, Monash University
Library - Exchange Desk, National Institute of Standards and Technology, US
Exchange Section, British Library Document Supply Centre
Periodicals Recording Section, Science Reference and Information Service, UK
Library, Chemical Abstracts Reference Service
Engineering Societies Library, US
Documents Librarian, The Center for Research Libraries, US

Director, Operational Policy Development, Maritime HQ Annex, Potts Point 2011
Manager, Ranges & Assessing Unit, Maritime HQ Annex, 54-56 Miller Street,
North Sydney NSW 2060
Task Manager, Torpedo Detection Processing, MOD Salisbury
Task Manager, MOD Salisbury Trials Management
Officer in Charge, PWO Training & Tactical Development, RANSWARS,
HMAS Watson, Watson Bay NSW 2030