

AD-A277 181

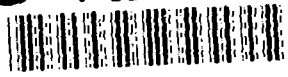

P

DIGISONDE 256

2

GENERAL DESCRIPTION OF THE
COMPACT DIGITAL IONOSPHERIC SOUNDER

K. Bibl, B.W. Rainisch, D.F. Kitrosser

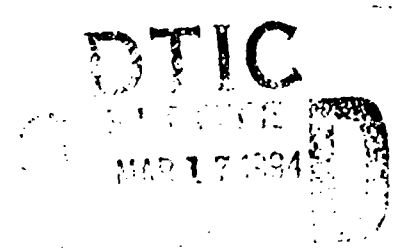

DECEMBER 1981

REVISED

FIRST EDITION

13496

94-08534



This document has been approved
for distribution to the public, its
contents are not to be disclosed
in any form or by any means
electronic or mechanical, including
photocopying, recording, or by any
information storage and retrieval
system, without the express written
permission of the University of Lowell
Center for Atmospheric Research.

UNIVERSITY OF LOWELL
CENTER FOR ATMOSPHERIC RESEARCH
450 Aiken Street
Lowell, Massachusetts 01854

07-2-16 050

DISCLAIMER NOTICE

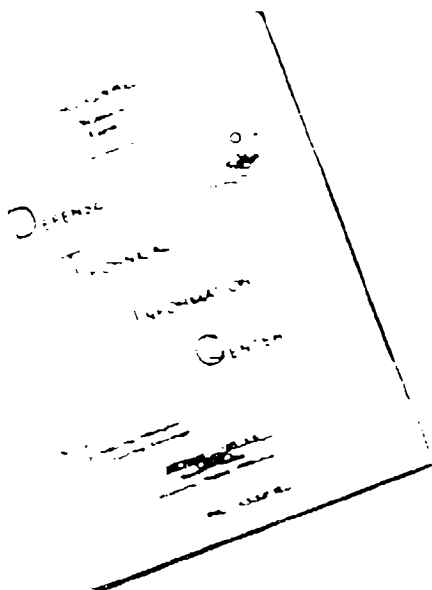

THIS DOCUMENT IS BEST
QUALITY AVAILABLE. THE COPY
FURNISHED TO DTIC CONTAINED
A SIGNIFICANT NUMBER OF
PAGES WHICH DO NOT
REPRODUCE LEGIBLY.

TABLE OF CONTENTS

	<u>Page</u>
SUMMARY	1
1.0 INTRODUCTION	3
2.0 ORGANIZATION OF THE DIGISONDE 256 SYSTEM	5
2.1 Remote Operation	5
2.2 Phase Code and Bistatic Sounding	9
Synchronization	9
2.3 Maintenance	9
2.4 Calibration	12
2.5 Testing	12
2.6 Analog Monitoring	14
2.7 Other Applications	14
2.8 Acknowledgement	15
3.0 THE MAIN DIGISONDE CHASSIS	15
3.1 The Controller Microcomputer	15
3.1.1 Description of the Controller	18
3.1.2 Programming of the Digisonde 256	26
3.2 Central Complex Correlator	30
3.3 Basic Timing and Data Flow	42
3.4 Interface Cards	50
3.5 Analog Cards	55
3.6 Output Computer	56
3.6.1 Processing of Ionogram Data	57
3.6.2 Tape Recording of Ionogram Data	59
3.6.3 Printing of Ionograms	63
3.6.4 Tape Recording of Drift Data	66
3.6.5 Realtime Printing of Drift Spectra	69
4.0 PERIPHERALS	69
4.1 Transmitter	69
4.1.1 Rack	70
4.1.2 Final Amplifier	70
4.1.3 Pulse Power	70
4.1.4 Delay Line	72

4.1.5 Operation and Maintenance	73
4.2 Antenna Switch	76
4.3 Realtime Ionogram Scaler	78
4.4 Magnetic Tape Drive	80
4.5 Hardcopy Plotter	83
4.6 Ionogram Display and Film Recording	84
5.0 SPECIFICATIONS FOR DIGISONDE 256	85
6.0 REFERENCES	103

LIST OF FIGURES

<u>Figure No.</u>		<u>Page</u>
2.1	Digisonde 256	6
2.2	Digisonde 256 with Peripherals	7
2.3	Digisonde 256 Block Diagram	8
2.4	Alternating Vertical and Oblique Soundings	10
2.5	Calibration Ionogram	11
2.6	Film Recording Format	13
3.1	Main Digisonde Chassis; Top View	16
3.2	Main Digisonde Chassis; Bottom View	17
3.3	CORE Block Diagram	31
3.4	Octant for Phase ϕ	38
3.5	Command Timing	41
3.6	B-Pulse Phase Code Leakage	47
3.7	Frequency Synthesis	52
3.8	RF Transceiver	54
3.9	Digicoder Fonts	64
4.1	Shunt M-Derived Low-Pass Filter	71
4.2	2 x 7 Turnstile Antenna Layout	77
4.3	Error Distribution Function for foF2	81

Approved For	
NAME	J
DATE	10/10/50
BY	form 50
A-1	

LIST OF TABLES

<u>Table No.</u>		<u>Page</u>
3.1	Time Correction Table	21
3.2	Drift Doppler Range and Resolution	28
3.3	Trig Argument Depending on Sample Number N, Doppler Line Number D and Doppler Spacing T3	33
3.4	DGS 256 Sample Advance	34
3.5	DGS 256-10 Log Trig Scaling	35
3.6	Log Trig Function in Hexadecimal Notation	37
3.7	Binary Log Table	43
3.8	Log Magnitude Correction C and Phase ϕ	44
3.9	Scope Monitor Program	46
3.10	64, 2 x 32 and 4 x 16 Pulse Sequence Codes and Second and Third Window Correlation	49
3.11	Tape Recording Command P1	58
3.12a	Record Format on Magnetic Tape for P1 = 1 (Routine MMM)	60
3.12b	Record Format on Magnetic Tape for P1 = 2	60
3.12c	Record Format on Magnetic Tape for P1 = 3	60
3.12d	Record Format on Magnetic Tape for P1 = 4	60
3.13a	Preface for Tape Recording	61
3.13b	Preface for Tape Recording (Continued)	62
3.14	Ionogram On-Line Printing	65
3.15	Drift On-Line Printing	68
4.1	2 x 7 Antenna Switch DGS 128PS-B	79
5.1A	DGS 256 Sounding Time Per Frequency in Ionogram	86
5.1B	DGS 256 Sounding Time Per Frequency in Ionogram	87
5.1C	DGS 256 Sounding Time Per Frequency in Ionogram	88
5.1D	DGS 256 Sounding Time Per Frequency in Ionogram	89

5.2	Frequency Steps DGS 256	90
5.3	DGS 256 Number of Samples, Pulse Rate and Width	91
5.4	Useful One and Two Chip Codes for DGS 256	92
5.5	Receiver Attenuation in 6 [dB] Increments	94
5.6	DGS 256 Sample Ranges	95
5.7	DGS 256 Ionogram Tasks	96
5.8	Definition of Antennas and Antenna Configuration DGS 256-08 Antenna Drive	97
5.9	Zenith, Azimuth Angle and Polarisation Sequences for Ionogram Mode DGS 256-08 Antenna Drive	98
5.10	DGS 256 Ionogram Start	100
5.11	DGS 256 Drift Tasks	102

GENERAL DESCRIPTION OF THE
COMPACT DIGITAL IONOSPHERIC SOUNDER DIGISONDE 256
K. Bibl, B.W. Reinisch, D.F. Kitrosser

SUMMARY

After the technical and operational success of the earlier digital ionosondes the new Digisonde 256 concept was chosen to combine the simplicity of the Standard Digital Ionosonde DGS 128P with the flexibility and the fast preprocessing speed of the Universal Digisonde 128PS. Contained in a standard 7-inch high chassis the Digisonde 256 includes a precise and fast digital frequency synthesizer, a transceiver for the frequency range from 0.4 to 30 MHz with front-end tuning, a high-speed digitizer, a versatile multichannel complex spectrum analyzer and a complete timing unit. These subsystems are controlled by a built-in front-end microcomputer which also programs the enclosed output microcomputer to optimize and format the data for display and recording on magnetic tape and hard copy.

Necessary peripheral equipment are a thermal dot printer and a wide-band pulse transmitter, while the 2 x 7 antenna switch, the magnetic tape recorder, the plasma display, and a post-processing computer for automatic ionogram scaling are considered optional peripherals.

Since the received data are multi-dimensional and the ionosphere and the background noise and interference are extremely variable with time and location, a system useful at any time and any location on earth must fulfill very exacting specifications. When automatic reduction of the ionospheric parameters is required even under adverse conditions, all signal properties must be measured. Coherent spectral integration and pulse coding are important for maximum signal-to-noise improvements in cases of high interference conditions, small transmitting antennas or low transmitter power limits. In spite of the complexity necessary for automatic recognition of polarization,

1.0 INTRODUCTION

The Center for Atmospheric Research of the University of Lowell (ULCAR) gained substantial experience in the design and operation of several digital sounding systems: a fixed frequency sounder for the AFCRL aircraft (1966), the Kinesonde built for NOAA (1967), the Low Frequency Sounder (1968) built for AFCRL, the Digisonde 128 (1970) which was and is in use at several ionospheric stations of AFCRL/AFGL and other institutes in U.S.A., Canada and Europe, the Standard Digisonde 128P (1974) operating in Italy and Greece, the Universal Digisonde 128PS (developed for DNA and AFGL, 1977) and the DMSP Spacecraft prototype (built for RCA, 1979).

Triggered by a request for a bid by the Rutherford and Appleton Laboratories, England, and the need of the Institut Royal Meteorologique to improve its Digisonde system for monitoring the ionospheric motions we have conceived the new Digisonde 256. It includes all the features of the Universal Digisonde 128PS, used as scientific instruments in the equatorial and the auroral regions of the earth, but is even more compact than the Standard Digisonde 128P which was mainly meant for routine observation of the ionosphere.

All the experience acquired with the prototype Digisonde 128PS installed for a year at Kwajalein, a Marshall Island in the West Pacific near the geomagnetic equator, and the other two Digisondes 128PS installed at the AFGL Goose Bay Ionospheric Observatory in Labrador and in the AFGL KC 135 aircraft to monitor the aurora ionosphere, contributed to the new design which has improved versatility, dynamic range and precision. By implementing two microprocessors (type 8085) the programming procedure and the data output selection have been simplified for the operator.

ULCAR has extensive experience in automatic recognition of the main echo traces in the ionograms (Reinisch et al, 1981; Reinisch and Huang, 1982) even under disturbed ionospheric conditions frequently observed in the auroral zone and during equatorial nights (Bibi,

Doppler speed and obliquity of the ionospheric echoes, the operation and the programming of the sounder are simple because of the built-in microcomputers.

An important feature of the Digisonde 256 is the possibility of remote programming via RS 232C modem interfaces over regular telephone lines or wireless communication networks. Also, output data can be communicated remotely. The built-in software clock can automatically change the programs on an hourly or daily basis. Because of the precision clock and frequency selection, bistatic sounding between different ionosondes is a standard feature and can increase the coverage of a network substantially.

Exclusive use of basic U.S.A. standard components, available almost everywhere in the world, minimizes storage requirements of spare parts. All printed circuit cards and transmitter drawers are easily accessible and can be tested and repaired under operating conditions without danger for personnel and equipment. Built-in test procedures and programs clarify the functions of the system and facilitate its operation and maintenance. Temperature margins of the components are sufficiently large to avoid equipment destruction if the system's fans fail in a thermostatically controlled environment or if the room air conditioning fails. Those design characteristics will allow a useful life of thirty years for the Digisonde 256.

1.0 INTRODUCTION

The Center for Atmospheric Research of the University of Lowell (ULCAR) gained substantial experience in the design and operation of several digital sounding systems: a fixed frequency sounder for the AFCRL aircraft (1966), the Kinsonde built for NOAA (1967), the Low Frequency Sounder (1968) built for AFCRL, the Digisonde 128 (1970) which was and is in use at several ionospheric stations of AFCRL/AFGL and other institutes in U.S.A., Canada and Europe, the Standard Digisonde 128P (1974) operating in Italy and Greece, the Universal Digisonde 128PS (developed for DNA and AFGL, 1977) and the DMSP Spacecraft prototype (built for RCA, 1979).

Triggered by a request for a bid by the Rutherford and Appleton Laboratories, England, and the need of the Institut Royal Meteorologique to improve its Digisonde system for monitoring the ionospheric motions we have conceived the new Digisonde 256. It includes all the features of the Universal Digisonde 128PS, used as scientific instruments in the equatorial and the auroral regions of the earth, but is even more compact than the Standard Digisonde 128P which was mainly meant for routine observation of the ionosphere.

All the experience acquired with the prototype Digisonde 128PS installed for a year at Kwajalein, a Marshall Island in the West Pacific near the geomagnetic equator, and the other two Digisondes 128PS installed at the AFGL Goose Bay Ionospheric Observatory in Labrador and in the AFGL KC 135 aircraft to monitor the aurora ionosphere, contributed to the new design which has improved versatility, dynamic range and precision. By implementing two microprocessors (type 8085) the programming procedure and the data output selection have been simplified for the operator.

ULCAR has extensive experience in automatic recognition of the main echo traces in the ionograms (Reinisch et al, 1981; Reinisch and Huang, 1982) even under disturbed ionospheric conditions frequently observed in the auroral zone and during equatorial nights (Bibl,

1980). It is easy nowadays to build simple ionosondes which work well at quiet mid-latitude locations where the interference level is 30 dB less than in the Eastern United States or 40 dB less than in Europe (Rush, 1981). But substantial sophistication is necessary in the design of a modern ionosonde capable of automatic trace recognition and ionospheric parameter extraction even in the presence of high interference levels and complex ionospheric conditions. It is not only the challenge of the interference but also the complexity and the dynamic range of the aurora echoes (High Latitude Supplement to the URSI Handbook on Ionogram Interpretation and Reduction, 1975) which require truth in the recorded amplitudes and the other signal parameters, as polarization, Doppler and incidence angle.

Although the Digisonde 256 is optimized for scientific investigations in many different applications, its operation is so simple and reliable that it can be tended by unskilled operators or used at unmanned stations.

2.0 ORGANIZATION OF THE DIGISONDE 256 SYSTEM

Commanded by a keyboard with program display the Digisonde 256 (Figure 2.1) consists of the main frame with Transceiver, Synthesizer, Digitizer, Spectrum Analyzer, Timing Unit, Controller and Output Microcomputer and several peripherals. Two necessary peripherals are a Wide-Band Pulse Power Amplifier (Transmitter) and a Printer; although the output data could be recorded remotely instead.

Optional peripherals are a magnetic tape recorder, a CRT or Plasma Display, an Antenna Switch for 2 x 7 Receiving Antennas (turnstile loops) and a Real-Time Ionogram Scaler (RIS) for On-Line Data Post-Processing (Figure 2.2).

Different commercially available models of peripheral equipment could be interfaced to the main frame of the system, but the proposed units can be directly connected because the hardware/software interfaces for them are built into the main chassis. For the transmitter, any wide-band antenna with 50 Ω impedance can be used. We recommend a vertical rhombus antenna of 600 Ω impedance for which we provide a matching wide-band transformer. For reception, one, four or seven turnstile antennas are recommended, although the transmitter antenna can be used for reception also via a tap in the final amplifier chassis of the transmitter.

2.1 Remote Operation

The block diagram, Figure 2.3, shows an overview of the whole system, emphasizing the remote programming and data output capability. It is also possible to put the transmitter, which should be always close to its antenna, at some distance from the Digisonde. A standard power outlet is required and two shielded cables of up to 1 km length are necessary for connecting the transmitter to the main Digisonde chassis.

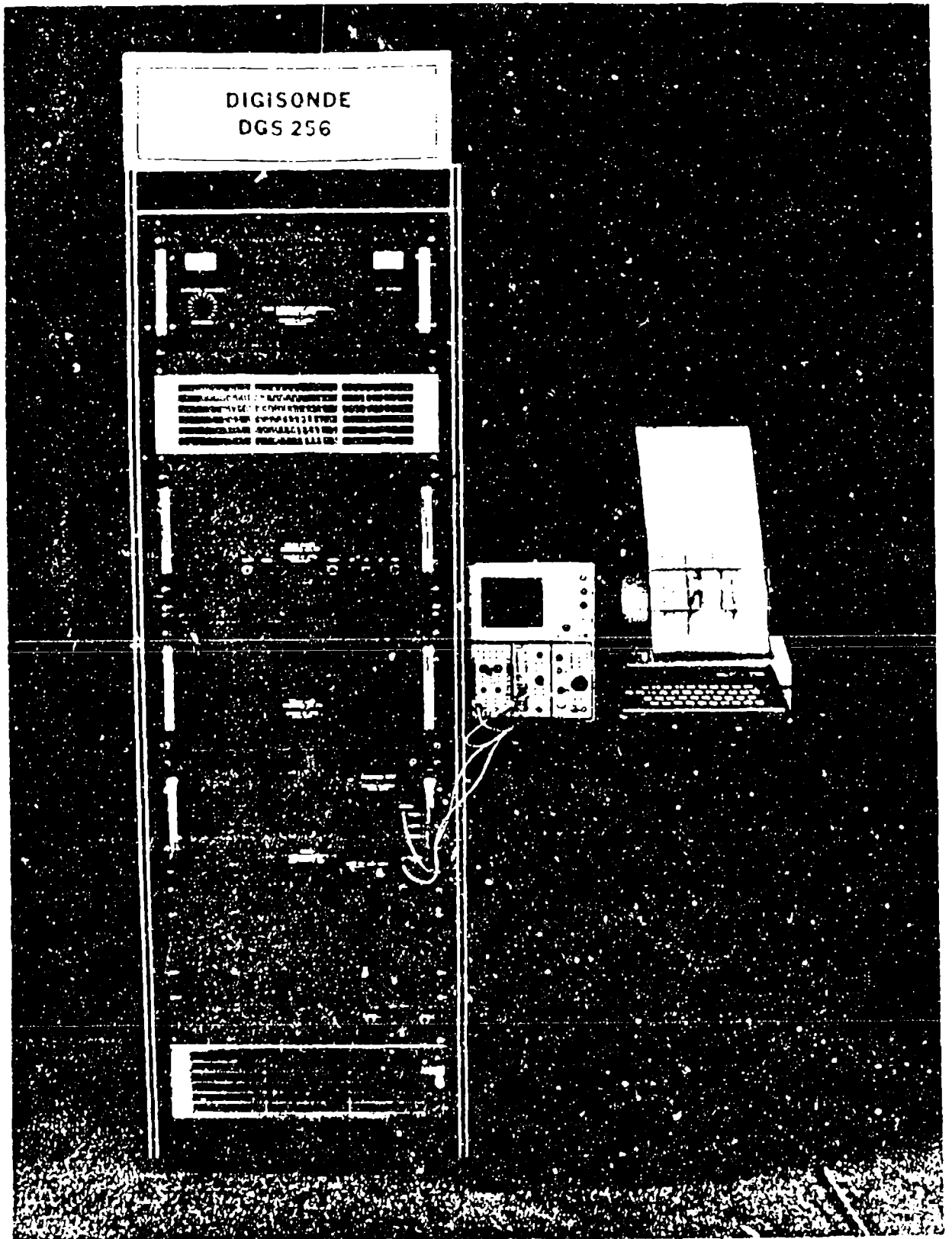

Figure 2.1. DIGISONDE 256

DIGISONDE
DUS 256

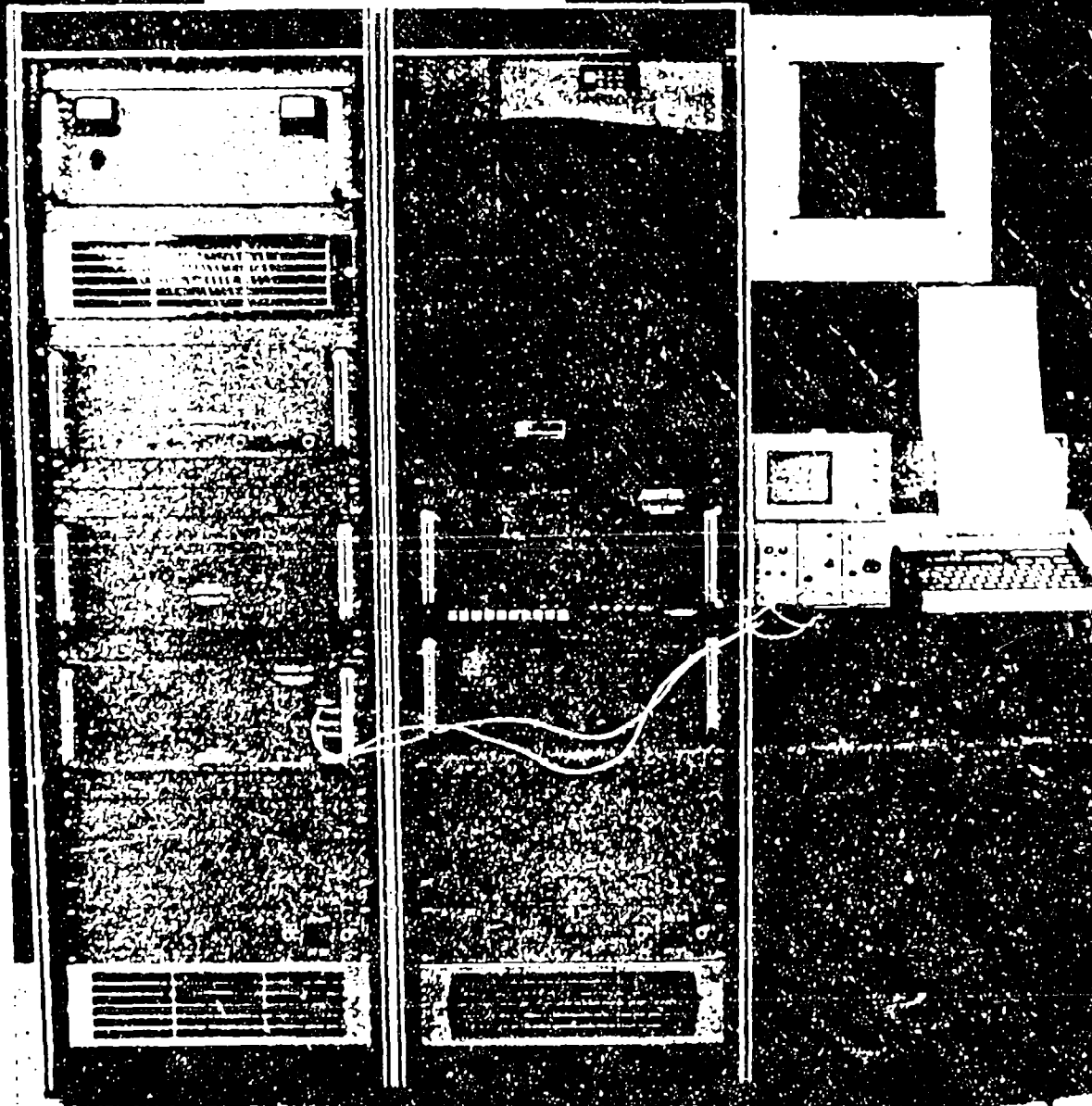

FIGURE 2.1. DIGISONDE 256 WITH PERIPHERALS

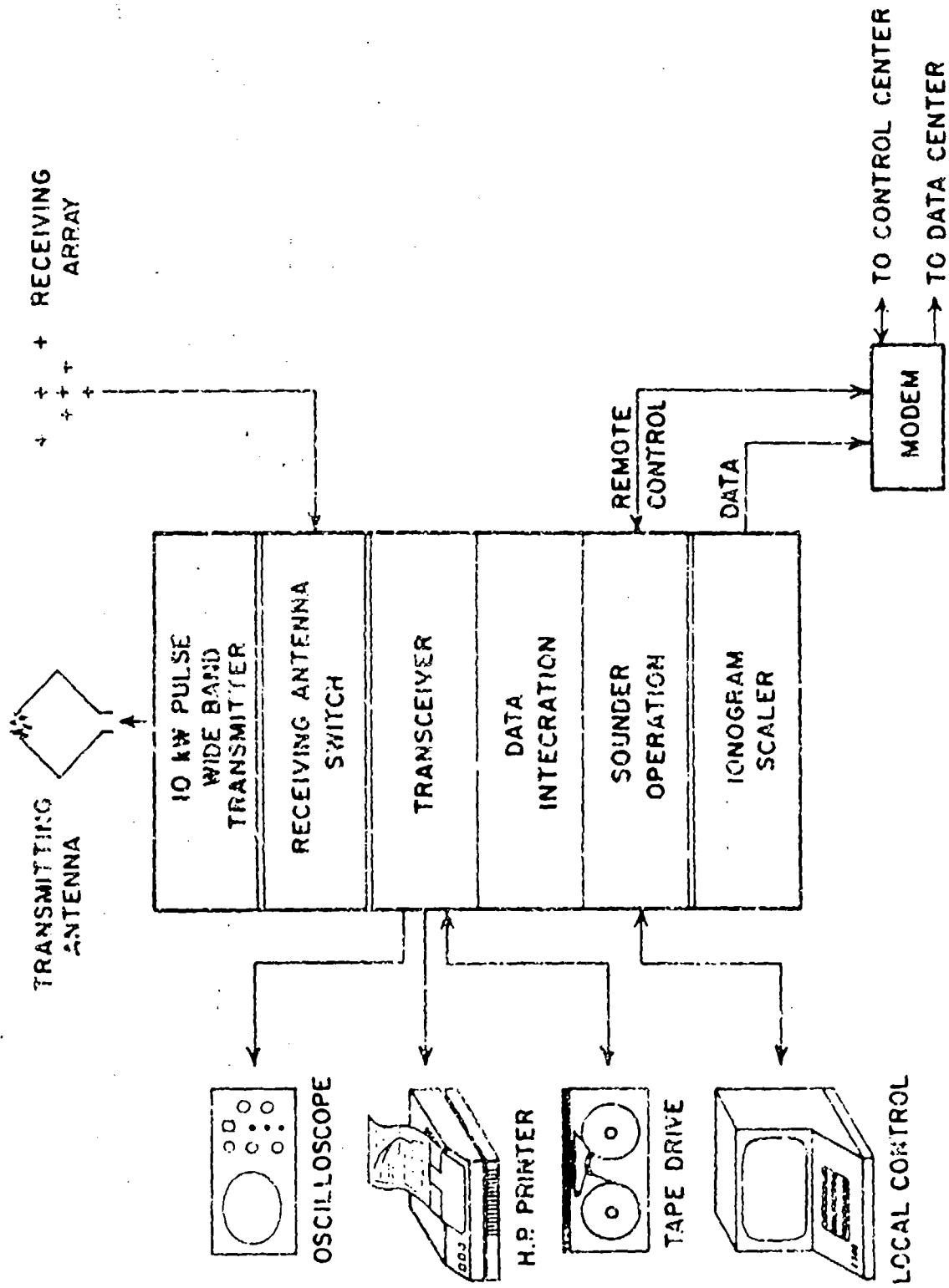

Figure 2.3

2.2 Phase Code and Bistatic Sounding Synchronization

To form a network of sounders and thus increase the coverage area of the stations, the Digisonde 256 is built specifically with oblique bistatic sounding as an important feature. It has a pulse sequence code which is dependent on the sample length (16 or 32 integrated pulses) and the number of interlaced antenna directions. To optimize the integration gain the number of used pulses should not decrease with the time delay of bistatic propagation. If the phase code starts with a sequence right after three equal (positive) phase decisions the last three of the prerun pulses which are used locally for establishing the gain can be used remotely as three delayed range windows. Alternating vertical and oblique sounding records are displayed on Figure 2.4.

2.3 Maintenance

Because of its reliability the Digisonde 256 can operate unmanned for a long time. Certainly paper and magnetic tape supply must be provided adequately, if local recording is required.

The filters of the fans should be cleaned monthly if the air contains dust or sand. Air-conditioning is recommended for many locations and a temperature warning system should be installed if the system is not regularly attended.

2.4 Calibration

A self-calibration mode of operation tests and calibrates the entire analog and digital system. In this mode a small fraction of the translator RF output is leaked into the receiver. The digitizing range is shifted over the transmitter pulse ($E = 1$), the correct phase code is selected ($X = 4$), and an ionogram scan is made. To prepare the self-calibration mode a toggle switch on top of card 40 must be set to Calibration. Figure 2.5 shows the resultant "calibration ionogram" for $H = 0$ (2.5 km height increments), $E = 1$ (10 km delay), $W = 2$ (20 km pulse width) and $Q = 0$ (200 kHz frequency increments). It is recommended to carry out this closed loop

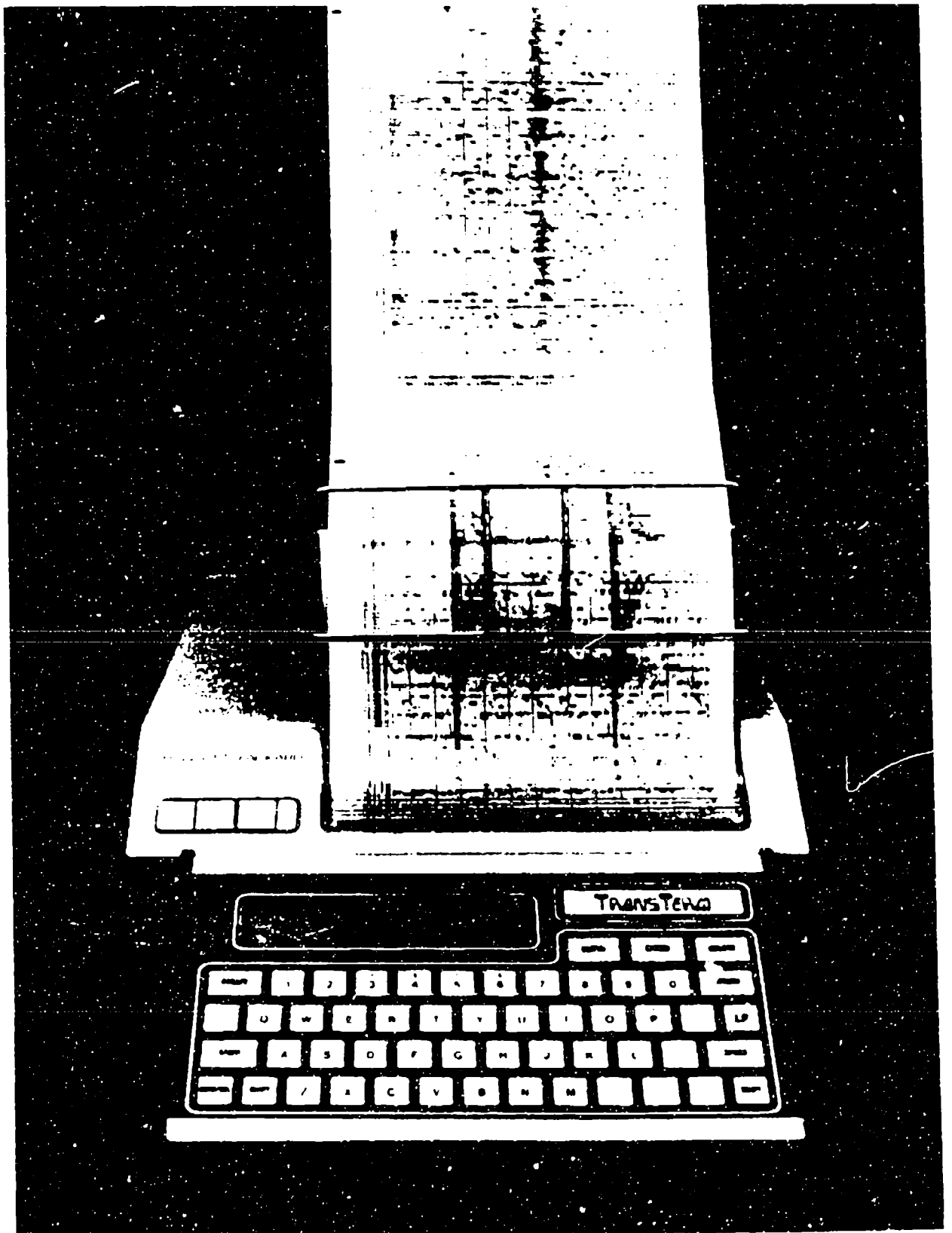
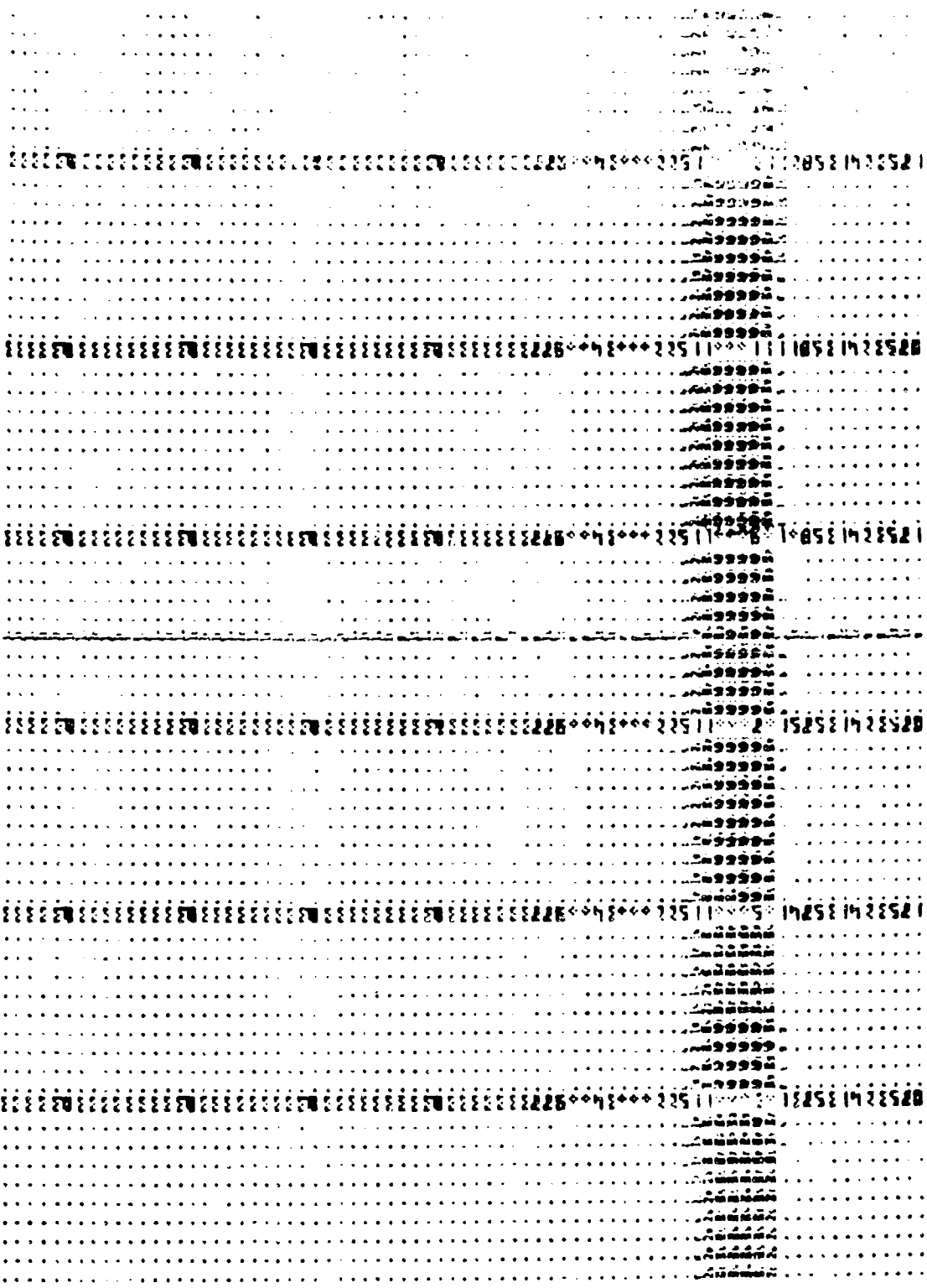

Figure 2.4. ALTEPNAING VERTICAL AND OBLIQUE SOUNDINGS



CALIBRATION IONOGRAM

Figure 2.5

calibration routinely. Automatic time controlled calibration can be provided as an option.

2.5 Testing

The digital integration algorithm and magnitude generation can be tested with built-in or external analog signals of 12.6 MHz. A calibrated attenuator (which, together with a HF oscilloscope possessing storage capability, should be standard test equipment for each ionosonde station) must be connected between the test output 225T and the 225 kHz input 225S of the Processing Controller. Thus, the log compression, the phase accuracy, the analog-to-digital conversions and the spectral integration can be tested.

This calibration shows the optimum range of 60 dB in which the log compression produces an output signal that changes linearly with the attenuation in dB. The Test card 40 permits phase changes of the calibration signal in 32 equal steps of 11.25° for the 225 kHz pulse or CW signal produced by dividing 12.6 MHz by 56. An external source of 12.6 MHz with good stability (10^{-7}) simulates Doppler shifted data if amplitude modulated by the transmitter pulse trigger. Calibration of the range and resolution of the Doppler analysis can be performed if the external frequency source is even more precise (10^{-8}).

2.6 Analog Monitoring

Although the DGS 256 is optimized for local and remote digital recording on magnetic tape and hard copy, it is possible to use the front panel outputs: Trigger (C) for trigger and Channel B for intensity modulation (B) of an oscilloscope monitoring the output computer processed data, in parallel to the customer-supplied oscilloscope recording using a continuously moving camera. The format of the ionogram is presented in Figure 2.6. At the data transfer time another output produces a sawtooth function synchronized with the selected data output provided by the output computer. Thus either a one-dimensional sweep for an A-scan or a two-dimensional ionogram display can be realized with the height

marks and the signal amplitudes (Channel B) added for Z-modulation of the long-persistence oscilloscope. In addition to immediate inspection of the ionospheric conditions the ionogram display can be used to create ionospheric movies.

2.7 Other Applications

In addition to ionospheric monitoring and research many other applications seem to be possible for the Digisonde 256. Most obvious are the multifrequency monitoring of the sea state by direct and ionospherically reflected sea scatter and infrasonic sounding using the same frequency but much shorter wavelengths for investigations of liquids and solids. Very challenging is a combined radio and acoustic experiment to probe the lower and middle atmosphere.

2.8 Acknowledgement

Significant inputs to the sounder specifications have been made by J. Buchau, J. Waaramaa and R. Gowell, U.S. Air Force Geophysics Laboratory, and G. Sales, Rome Air Development Command, Hanscom Air Force Base, Bedford, MA. Help in the hardware design and testing by X. Qiu and R. Bemis (ULCAI) is acknowledged. Firmware programs have been developed by E. Li and T. Peng (ULCAR). Drawings and printed circuit artwork were prepared by A. Cognac. S. Johnson composed the brochure.

3.0 THE MAIN DIGISONDE CHASSIS

As explained in Section 2.0 the main Digisonde chassis (Figures 3.1 and 3.2) contains the frequency synthesizer, the transceiver, the spectrum analyzer, the fast timing units, the Controller Computer and the Output Computer. The chassis can operate self-contained with two fans in the front panel. But normally it will be mounted either in the Tape Recorder Rack or in the Transmitter Rack.

A separate keyboard terminal with a LCD display of 64 characters is provided. This terminal, connected to the Controller Microcomputer, monitors the Digisonde operation and permits modification of its programs and schedules.

3.1 The Controller Microcomputer

As an interface between the serial RS 232C port which connects to the telephone line or the programming keyboard terminal the Controller interprets commands received from the port and acts upon them controlling the Digisonde as well as displaying the significant program parameters and/or the time and sounding frequency information. The Controller consists of three standard industrial cards containing the Intel 8085 CPU, standard RAM and EPROM chips and serial Input/Output services (card 01) for the RS 232C port. Their address/data bus is connected to I/O ports on four cards of the Central Complex Correlator (CORE) as well as on the Output Computer (OUTCO). The computer codes for the microprocessor (hereafter referred to as software) are stored and accessed as firmware in PROMs on cards 02 and 03.

3.1.1 Description of the Controller

The Controller software generates the operational control words (repetition rate, pulse width, sounding frequency, antenna configuration, phase code, etc.) and transfers them to CORE on a 6-line extension of the Controller Computer address/data bus. Updating of the control words occurs every 1/8 second, initiated by an interrupt command arriving from the CORE timing unit. This



precise (1 part per 10^8 per day) command also advances the software clock. Since the sounding frequencies are software-selected any desired sequence can be realized. Linear and logarithmic sequences with selectable step sizes are provided for regular ionograms. Optionally, a quasi-random frequency sequence could be employed by adding a look-up table to the software.

Ten different sets of ionosonde operating programs, each set consisting of an A, B and C ionogram and a drift program G, and three fixed frequency programs F are stored permanently in one of the Controller PROM's (the program PROM). Three of the ten sets and one of the fixed frequency programs can be loaded into the working memory RAM for possible modification and subsequent execution.

3.1.2 Programming of the Digisonde 256

Since the handheld keyboard display changes automatically with the Controller parameters or the part of the program to be modified, changes are executed very easily with the keyboard. The following explains the command words and summarizes the associated software. More detailed information is contained in the software listings.

Commands typed on the keyboard overwrite the normal display. At the end of the command the CARRIAGE RETURN key is pushed executing the command and clearing the command word from the display. If the command is rejected for any reason, the message "INPUT ERROR" appears on the display. The operator clears this error message by typing the carriage return again. In all of the commands described below only the first three letters are significant although no harm is done by typing the full word.

DISPLAY - shows on the display the actual frequency of a running ionogram or the preceding ionogram if the Digisonde is not running, the time, the ionogram type [A, B, C, F (for fixed frequency)] or G (for Drift), the program set number (1, 2, or 3), the beginning frequency of the ionogram (FR), the frequency step

parameter Q, the end frequency (UY) and the other ionogram program parameters CABXLZTNRWHEIGO. The actual gain in -6 dB steps (0 to 8) and the searched frequency (1 to 3), selected for minimum interference, are read from the CORE and displayed under the flashing G and I positions.

The only parameter which can be modified (by use of an "equal sign" command, described later) in the DISplay mode is the letter "O". "O" selects automatic operation of the ionosonde interleaving A, B, and C scanning ionogram programs according to fifteen different schedules which repeat every hour. There are three "O"'s, one for each of the three program sets. The "O" appropriate to the program set (1, 2 or 3) shown on the display is the "O" which is displayed and is also the one which can be modified. The "O" parameter can also be specified by the World Day function. The exact meaning of all of the "O" parameters is described in Table 5.10. Note that O = 0 means no automatic start and an O = 7 is the default setting, one C ionogram on the hour (actually HH:59:16). O = 8 is reserved for a user specified program which is stored in RAM.

O8A, O8B, O8C commands allow the user to construct a special sequence for O = 8 with A, B and C ionograms respectively. Typing O8A, for example, shows on the terminal display all of the A ionogram starting times in the O = 8 sequence. To add a starting time use an equal sign command. The parameter being changed is A, B, or C depending on whether O8A, O8B, or O8C had been the command. There are six (A1 A6, for example) possible starting times for each A, B or C program. Specifying a starting time of 60 (minutes) for any location deletes the starting time at that location from the list.

TIME shows the actual time along with a time-setting-buffer. Equal sign commands (described later) allow modification of the time setting buffer. The complete actual time includes two digits for year, three digits for day and two digits each for hours, minutes, and seconds. Also in the TIME mode the parameter K may be set. When

K is other than zero (see Table 3.1) it causes the dividers in the CORE timing unit to depart from the correct divisor and thus effect a lag or lead of the clock with respect to a standard reference signal such as WWV. Timing can be adjusted with ten microseconds resolution in this manner, an important consideration if bistatic sounding is contemplated.

SET - when in the TIME mode typing SET causes the time in the time-setting-buffer to be transferred into the actual clock of the system at the moment of the carriage return.

LOAD - moves a specified set of programs from permanent PROM storage into RAM where they are accessible to PROGRAM and RUN operations. In the operating RAM at any one time there are three sets of programs (1, 2 and 3) and one fixed frequency program (F). Each set of programs consists of an A, B, C (scanning ionogram) and G (drift) program. The sets permanent in PROM are numbered 11, 12, ..., 20. The three permanently stored fixed frequency programs are numbered 21, 22, 23. For example the command "LOAD 1 13" or "LOAD 13 1" moves the number 13 PROM program into RAM as set 1. LOAD 21 moves the number 21 fixed frequency program into RAM as the fixed frequency program, F.

At power up or at system reset, sets 11, 12, 13 are loaded automatically as program sets 1, 2 and 3. After the user of the Digisonde has experience with local conditions and requirements the parameters in these default sets can be altered by ordering a replacement program PROM from ULCAR. After the LOAD command is executed, the terminal display shows which of the permanent PROM sets are loaded into RAM as sets 1, 2, 3 or F. This type of display can be activated also by typing only LOAD followed by a carriage return.

SET - Typing SET 1, SET 2 or SET 3 changes the active program set number accordingly. The automatic operation controlled by the "O" parameter selects only A, B, or C scanning ionograms

K	Time Correction		Division
	[msec/sec]	[km/sec]	
0	0	0	
1	-200	-30,000	5
2	- 50	- 7,500	4
3	- 10	- 1,500	5
4	- 2	- 300	5
5	- .4	- 60	5
6	- .1	- 15	4
7	- 0.025	- 3.75	4
8	0	0	
9	+200	+30,000	5
A	+ 50	+ 7,500	4
B	+ 10	+ 1,500	5
C	+ 2	+ 300	5
D	+ .4	+ 60	5
E	+ .1	+ 15	4
F	+ .025	+ 3.75	4

MOVES
 W/V
 to right
 →

TIME CORRECTION TABLE

8011 2802
 B1 1 Oct 81

Table 3.1

Monitor E00D

within a particular SET in a sequence which repeats every hour. The number of the active program set (as well as the "O" parameter) can be changed by the World Day function which is programmed through the WDAY command described later. The World Day function can change the program SET number on either a diurnal basis (for example - change sets for different day and night operation) or make a change of SET number on a particular day and hour.

PROGRAM - allows the display of all the parameters associated with any one of the thirteen programs stored in RAM at any one time. All of the ionosonde operating parameters as well as options for the output computer and its peripherals are displayed and may be modified. For example, the commands PROgram A1, PROgram C3, PROgram G2, or PROgram F each refer to a particular ionosonde operating program in each of which parameters can be changed with the equal sign commands. Even though the PROGRAM command includes a reference to a particular program SET number, the program SET number selected by the Digisonde is unaffected. This allows modifying a new SET with PROGRAM which is not the current operating SET prior to the actual selection of the new SET.

FIXED is equivalent to typing the command PROgram F.

RUN - starts the manual operation of the Digisonde. Typing RUN followed immediately by a carriage return causes the last program which ran to be repeated. Typing RUN A, RUN B, RUN C, RUN G or RUN F causes the specified program in the program set currently in use by the Digisonde to run. Typing RUN A1, RUN C3, etc. also effects a change of program SET number if the number tapped is different from the current program set. Note that this manual RUN command acts immediately, within the next 1/8 second in the case of drift (RUN G) or on the whole second for all the other programs; no memory is retained of what the Digisonde was doing prior to the command.

When operation starts automatically based on the "O" parameter while the Digisonde is in the fixed frequency or drift mode of operation, after the automatically selected scanning ionogram is completed the operation reverts back to the fixed or drift operation.

In the case of automatically selected scanning A, B, or C ionogram operation, the first transmitted pulse occurs at 16 seconds after the exact minute or 1/2 minute at which the automatic operation was selected. The 16 seconds allow enough film motion to record a heading on film prior to the ionogram. By typing RUH instead of RUN for a manually started ionogram the same 16 seconds delay can be achieved.

STOP immediately terminates a scanning (i.e. A, B or C) ionogram program which may be running. If the scanning ionogram program had been selected automatically the drift or fixed frequency operation would begin again if either had been selected prior to the automatic start of the scanning program. STOP F or STOP G (or just STOP if in FIXed or DRIFT mode) stops fixed frequency or drift operation.

DRIFT changes the display to show the four frequencies, heights and gains specified in the G (drift) program for the program set which is currently selected. When the DRIFT display is selected, the four frequencies, heights and gains may be modified by the Equal Sign commands. If the command RUN is typed while DRIFT is displayed the Digisonde commences with the drift program, i.e. it is not necessary to type the full command RUN G1, RUN G2 or RUN G3.

WDAY (World Day) command selects a display of the world day buffer in which the day numbers and hours for up to three possible times are stored. These are the times at which the program SET number and automatic schedule parameter, "O", can be changed according to the SET and "O" parameters following the three respective times. If a day number zero is specified, then the change occurs every day at the hour set into the buffer allowing diurnal

changes to the operating ionosonde programs as well. The parameters in the World Day buffer are changed through use of the equal sign command. Specifying SET 0 (S1 = 0 for example) causes the software to ignore that entry into the World Day buffer. This World Day function can be used to change only the "O" parameter if desired.

TTY command changes the serial output of the controller computer to a format suitable for a printing terminal. The display is not continually refreshed but rather is reprinted upon every carriage return received. The baud rate may have to be reset on the SIO card 01 according to the terminal actually in use. The serial I/O is standard RS 232; to drive a mechanical teletype (ASR-33 for example) directly from the port a current loop adapter would be required.

CRT command changes the serial output to a format suitable for a video CRT type terminal. The complete display is refreshed repeatedly so that a baud rate of at least 1200 Baud is necessary if a rapidly responding display is desired.

TTM command changes the serial output back to the format suitable for the supplied TransTerm LCD terminal. This terminal presents a rapidly responding display even at 300 Baud since its addressing capability allows the controller computer to rewrite only the characters which change in the display.

Equal Sign Commands are commands which allow replacement or modification of stored parameters. An equal sign command must have an = sign in it, hence the name. For convenience, instead of the "equal sign" key the "semicolon" key can also be used thus avoiding the simultaneous operation of the "shift" key necessary to make an equal sign. Only parameters which are displayed can be altered by the equal sign command so that one sees the changes effected by the command in the display. The parameter to be changed is identified by one letter; it may be followed by a digit if the same letter is used repeatedly such as in drift mode where there are four frequencies, four heights and four gains displayed. Also in the O8A, O8B and

O8C modes the parameters A, B, C respectively must have one of the digits 1 to 6 following the letter.

There are three options for altering a parameter with an equal sign command. Using frequency in the drift mode as an example, F1 = 12.36 replaces the first frequency with 12.36; F2 = +.10 increases the second frequency by 0.10 MHz; F4 = -1.56 decreases the fourth frequency by 1.56 MHz.

The computer software knows how many decimal places to use in all cases. Any excess digits to the right of a decimal point are ignored. Any excess digits to the left of a decimal point cause an input error. Most parameters are single digits and typing R = 3, for example, without a decimal point is adequate. The aforementioned drift frequency with two digits each side of the decimal point is the most exotic use of this fixed point data entry scheme.

Many of the single digit parameters can have hexadecimal values, i.e. values, 0 15 (= 0 9, AF). With these it is allowable to type either R = B or R = 11, for example; the display on the terminal will show the parameter B under the R in either case. You may type the letters A ... F for the multidigit parameters also but this may result in nonsense. The only exception is for Height in the drift mode. Typing H3 = F90 or H3 = 1590 will both set the third height gate to 1590 km. The display in this example will show F90 since there is room only for the three digits.

There are some further commands which are not controls for the Digisonde per se, but for the peripherals connected to the output computer (OUTCO).

FWD - the forward command simply causes the tape recorder to run forward as a convenience when searching for a particular ionogram during playback of a tape.

REV - same as the FWD command but in reverse.

STOP - causes the tape recorder to stop all activity except the writing of data which is controlled by output options in a Digisonde operating program. If the STOP command is used when the tape recorder is in motion (generally during a playback operation) it will have effect only on the tape recorder. If used when the tape recorder is not running in a operation initiated by commands FWD, REV, READ or REW then STOP has the usual effect of stopping a running monogram, fixed frequency or the drift operation.

EOF puts an end of file on the tape after the last record read or written. If the tape has gone past the End of Tape marker (EOT) then the tape is backspaced one record and an EOF written there.

REW rewinds the tape completely (not just to the load point) leaving the reel ready for demounting.

READ - reads a tape, processes the data being read, and prints it out.

3.2 Central Complex Correlator

The Central Complex Correlator (CORE) resembles the Processing Controller of the Digisonde 128PS (Bibl and Reinisch, 1978). It is, however, packaged in much less card space using more advanced random access memory (RAM) chips. A high resolution (12 bit) A/D converter allows linear amplitude digitization with the full dynamic range of 64 dB and reasonable phase resolution at low amplitudes. The dynamic range of the Integrator is increased to 96 dB; this permits a full dynamic range of at least 60 dB in those operational modes where the input data are scaled down by 36 dB to accommodate 2×512 integrated samples. Since noise and some Doppler variations are always present the actual dynamic range is actually larger than 60 dB for the processed data. Readout accuracy can be 3/32 dB for the larger amplitudes and 1.4° resolution of the signal phase for each doppler line. While the large dynamic range is of paramount importance for many occasions, the available accuracy will rarely be used.

Utilization of microprocessors and other large-scale integrated circuits allowed consolidation of the programming functions, the digitization, integration and spectrum analysis in one-half of a card file.

In the Drift mode, the CORE digitizes multiplexed time series from one to seven antennas and one to four frequencies for a maximum of 16 channels. For each antenna up to four channels are provided for which the operating frequency, the receiver gain and the height range settings are independently selectable. The sequence of those settings is automatically switched after each group of pulses; the signals from the first pulse of each group is received with loop antenna 1, the second with antenna 2, etc.

For full Drift analysis, the Digisonde 256 requires a special receiving antenna array and antenna switches. Conversely, in the ionogram mode the Digisonde employs this antenna system by connecting all used antennas parallel as a phased array and receives the benefits of a circularly polarized directional receiving antenna array. The Drift mode can be used for multiple fixed-frequency absorption measurements, if only one receiving antenna is available ($L = 6$ or E ; see Table 5.11). The full Doppler spectrum of the received echo amplitudes is recorded, as indicated in Table 3.2.

The ionograms serve as a diagnostic tool for optimizing the program parameters in the Drift mode. Preferably one would alternate between the normal ionogram operation and multi-antennae Doppler measurement.

In the Ionogram mode, the CORE creates all necessary timing functions for the transmitter pulse and for the 128 or 256 consecutive sampling ranges, the sequences of the phase codes for the transmitter and the receiver phases and the translation of the digital frequency commands from the Controller for the analog circuits.

Ant.	Freq.	A x F	L =		No. of Channels	Integration Time [sec]		Doppler Range [Hz]	
			1H	2H 8H		Min.	Max.	Min.	Max.
1	1	1	0	6	2/8	.32/1.3	5.1/20.5	±25/6.25	±100/25
1	2	2	8	E	4/16	.64/2.6	20.5/41.0	±12.5/3.1	±50/12.5
4 I	1	4	2		8	1.28	20.5	±6.25	±25
4 I	2	8	1	A	8/16	2.56	81.9/41.0	±3.1	±12.5
4 I	4	16	9		16	5.12	81.9	±1.56	±6.25
4 O	1	4	4		8	1.28	20.5	±6.25	±25
4 O	2	8	7	C	8/16	2.56	81.9/41.0	±3.1	±12.5
4 O	4	16	F		16	5.12	81.9	±1.56	±6.25
8	1	8	D		16	2.56	41.0	±3.1	±12.5
8	2	16	3	5	16/32	5.12	81.9/41.0	±1.56	±6.25
8	4	32	B		32	10.24	81.9	±.78	±3.1

Doppler Resolution = Reciprocal Integration Time [in Hz] for T3 = 0
 - 2 x Reciprocal Integration Time [in Hz] for T3 = 1

DRIFT DOPPLER RANGE AND RESOLUTION

Table 3.2

8107 0201
 B1 12 Oct 81

CONTINUOUS OR FINITE LENGTH DRIFT MEASUREMENT

The "frequency" input parameter in a DRIFT program specifies the number of drift measurements (cases). Similar to the modification mode for FIXED frequency programs, a maximum number of 49 measurements is achieved by a 0.49 MHz frequency. While a frequency set equal to 0.00 MHz in a DRIFT program indicates continuous DRIFT measurement. The four actual sounding frequencies in DRIFT are still set in the DRIFT buffer.

For Doppler measurements in the Drift mode one, two or four frequencies are selected and the respective height gates set to monitor the desired echoes. These gates can be set by one hexadecimal and two decimal characters as 1 km unit numbers; but the actual range increments have 2-1/2 km step size. The four programmed values are consecutively scanned, as to provide that each group of pulses is transmitted and received at a different frequency and the echo digitized at a different height range. By selecting the same frequency in two or more consecutive units, different height gates at the same frequency can be selected; in normal operation, one height gate at each frequency is sufficient for drift measurements where four antennas are consecutively fed to the receiver. To speed up integration, two ranges can be set within the same transmitter pulse in one or two frequency operation. H3 can be programmed as second height for frequency 1 and H4 can be programmed as second height for frequency 2. For this mode of operation L = 0, 2, 4, 5, A, C or D (see Tables 3.2 and 5.11).

Under normal conditions the Drift mode, i.e. the multiple fixed-frequency operation on switched receiving antennas, is alternated with the Ionogram mode in a complete cycle of either 1.0, 2.5, 5, 10 or 15 min. In the fast cycle, ionograms of up to 80 sec (i.e. 0 to 16 MHz in 100 kHz increments and 1/2 sec integration, or 2 to 10 MHz with 50 kHz stepping) are possible each 2.5 min, allowing 64 sec for the drift measurement. In the 15 min cycle much longer ionograms are permitted for oblique sounding and fine spectral analysis with multiple antenna direction steering; but the drift measurements should not be interrupted for more than 5 min.

Although wide flexibility is provided with regard to program starts and lengths, use of certain standard start times is recommended for background ionogram information on a routine basis. For that reason the Digisonde 256 contains a complete digital clock in software with starting times at preprogrammed minutes and seconds. These programmed starts are suppressed when an ionogram is not finished before the next wants to start. This overriding feature is

also applied in the sequence between ionogram and drift operation. If the RUN G1 command has been issued Drift measurements start immediately after each ionogram and get switched off by the next programmed ionogram.

3.3 Basic Timing and Data Flow

The CORE comprises 14 printed circuit cards. Most cards have a single, well defined, function to minimize interconnections and facilitate testing. Figure 3.3 shows the block diagram of the chassis indicating all printed circuit cards, their functional names and the principal interconnections, as well as the main input and output functions.

The CORE file operates from a 12.6 MHz frequency source located in the Analog file of the Digisonde. The Command card 09 buffers the sinusoidal input and provides the first dividers generating 6.3 and 2.1 MHz as well as 60 and 30 kHz frequency sources. The card creates the basic time chains of pulses for the digitizing as well as for the interlaced integration including all trigonometric function generation, averaging, multiplication and summation. The 300 kHz output provides also Clock Synchronization. Its output is a possibly modified 300 kHz which is divided further by 5 and 2 and fed to the Rate card. The Rate card 06 decodes and stores the values of the program characters K, W, R, N and T. Controlled by the R program the Rate card produces either 50, 100 or 200 Hz pulse repetition rate. This card determines also the width of the transmitter pulse controlled by the W function, as well as the group of pulses prior to the actual integration for finding frequencies with low interference, dependent on the value of the program parameter I.

The search around the assigned sounding frequency for the frequency with the lowest interference level is executed on the Search card 11. Also on this card is the Automatic Gain Control (AGC) which selects for each frequency one of four levels, spaced by 6 dB,

dependent on the amplitudes of interference and signal for each frequency (Table 5.5).

To display the raw digitized data prior to integration, a switch on the Search card channels either the sum C_n of the log sample weight (Hanning) and the log sine or log cosine of the trigonometric spectral weighting function or the log Product function Q_n onto the Display bus I_n for display on channel B or test printout. If only the digitizer sine and cosine data samples should be tested the Log Trig card 10 can be replaced by a dummy card which puts a weight of 1.0 onto the input of card 12.

The I parameter modifying the use and the spread of the frequency spacing of the searched frequencies (Table 5.7b) is stored on the Spacing card 07 where also the H and the E parameters are stored. All the three parameters HEI need quadruple storage since they serve as range parameters in the drift mode permitting interlaced scanning of four ranges almost simultaneously. In the Ionogram mode, however, H determines the spacing and E the beginning of the range samples (Table 5.6).

One of the most interesting schemes of the basic design is the fast production of the 128 angular arguments (one for each Doppler frequency) at each data sample (Table 3.3). A sample counter output is successively multiplied with all used ω_m values by adding in a loop the counter output for the nth sample $Arg_n [1]$ to its preceding sum: $Arg_n [\omega] = Arg_n [\omega-1] + Arg_n [1]$. This function is created on the Log Trig card 10. Controlled by the T and N characters of the program, the Sample Counter is updated with 1 to 8 clock pulses for each transmitter pulse. Since the counter input is switched also to by-pass a divider by 8 and/or a divider by 16, the counter steps always through its full count during the integration time (see Table 3.4).

Unequal spacing of the Doppler lines near zero frequency, one of the limitations of the DGS 128PS system, has been overcome in the

	1	2	3	5	9	17	33	65	97	129	161	193	225	241	249	253	255	256
0	768	769	770	772	776	784	800	832	864	886	928	960	992	1008	1018	1020	1022	1023
"	256	259	262	268	280	304	352	448	544	640	736	832	928	976	1000	1012	1018	1021
Σ	768	773	778	788	808	848	928	64	224	384	544	704	864	944	984	1004	1014	1018
2D=	256	263	270	284	312	368	480	704	928	128	352	576	800	912	968	996	1010	1017
"	768	777	786	804	840	912	32	320	608	896	160	448	736	880	952	988	1006	1015
Σ	256	267	278	300	344	432	608	960	288	640	992	320	672	848	936	980	1002	1013
2D=	768	781	794	820	872	976	160	576	992	384	800	192	608	816	920	972	998	1011
"	256	271	286	316	376	496	736	192	672	128	608	64	544	784	904	964	994	1009
Σ	512	514	516	520	528	544	576	640	704	768	832	896	960	992	1008	1016	1020	1022
"	512	518	524	536	560	608	704	896	64	256	448	640	832	928	976	1000	1012	1018
Σ	512	522	532	552	592	672	832	128	448	768	64	384	704	864	944	984	1004	1014
2D=	512	526	540	568	624	736	960	384	832	256	704	128	576	800	912	968	996	1010
"	512	530	548	584	656	800	64	650	192	768	320	896	448	736	880	952	988	1006
Σ	512	534	556	600	688	864	192	896	576	256	960	640	320	672	848	936	980	1002
2D=	512	538	564	616	720	928	320	128	960	768	576	384	192	608	816	920	972	998
"	512	542	572	632	752	992	448	384	320	256	192	128	64	544	784	904	964	994
Σ	257	258	259	261	265	273	289	321	353	385	417	449	481	497	505	509	511	512
0	0	1	2	4	8	16	32	64	96	128	160	192	224	240	248	252	254	255
"	0	3	6	12	24	48	96	192	288	384	480	576	672	720	744	756	762	765
Σ	0	5	10	20	40	80	160	320	480	640	800	960	96	176	216	236	246	251
2D=	0	7	14	28	56	112	224	448	672	896	96	320	544	656	712	740	754	761
"	0	9	18	36	72	144	288	576	864	128	416	704	992	112	184	220	238	247
Σ	0	11	22	44	88	176	352	704	32	384	736	64	416	592	680	724	746	757
2D=	0	13	26	52	104	208	416	832	224	640	32	448	864	48	152	204	230	243
"	0	15	30	60	120	240	480	960	416	896	352	832	288	528	648	708	738	753
Σ	0	4	8	16	32	64	128	256	320	384	448	448	448	480	496	504	508	510
2D=	0	6	12	24	48	96	192	384	576	768	960	128	320	416	464	488	500	506
"	0	10	20	40	80	160	320	640	960	256	576	896	192	352	432	472	492	502
Σ	0	14	28	56	112	224	448	896	320	768	192	640	64	288	400	456	484	498
2D=	0	18	36	72	144	288	576	128	704	256	832	384	960	224	368	440	476	494
"	0	22	44	88	176	352	704	384	64	768	448	128	832	160	336	424	468	490
Σ	0	26	52	104	208	416	832	640	448	256	64	896	704	96	304	408	460	486
2D=	0	30	60	120	240	480	960	896	832	768	704	640	576	32	272	392	452	482

TRIG ARGUMENT DEPENDING ON SAMPLE NUMBER N, DOPPLER LINE NUMBER D AND DOPPLER SPACING T3. ARG(N, 2D) = 2D(N-257) (MOD 1024)

Table 3.3

YY	Pulse Number	$\Sigma T = M \times L (M = 2^{N+1}; L = 2^T)$	Count
0	4 x 1		1 x 1 x 1
4	4 x 2; 8 x 1		2 x 1 x 1
8	4 x 4; 8 x 2; 16 x 1		4 x 1 x 1
C	4 x 8; 8 x 4; 16 x 2; 32 x 1		8 x 1 x 1
1	8 x 8; 16 x 4; 32 x 2; 64 x 1		1 x 16 x 1
5	16 x 8; 32 x 4; 64 x 2; 128 x 1		2 x 16 x 1
9	32 x 8; 64 x 4; 128 x 2; 256 x 1		4 x 16 x 1
D	64 x 8; 128 x 4; 256 x 2; 512 x 1		8 x 16 x 1
7	64 x 16; 128 x 8; 256 x 4; 512 x 2		2 x 16 x 8
B	64 x 32; 128 x 16; 256 x 8; 512 x 4		4 x 16 x 8
F	128 x 32; 256 x 16; 512 x 8		8 x 16 x 8

8102 2007
 B1 14 Mar 81
 Rev. 1 Sep 81

DGS 256 SAMPLE ADVANCE

Table 3.4

DGS 256. For narrow spectrum spacing the trigonometric functions are taken at odd multiples of one-half Doppler unit: i.e. at $\pm 1/2$; $\pm 3/2$; $\pm 5/2$; $\pm 7/2$, etc. times the reciprocal sample length. Thus only one-half period of the trigonometric function is covered for the first Doppler measurement and $3/2$ for the next, etc. To arrive at zero phase in the middle of the sampling period the basic argument counter is set to 270° , bringing the counter over $360^\circ (= 0^\circ)$ to 90° at the end of the sampling period. In reality the count is produced by a 12 bit binary counter. The total argument for the Doppler channel ω_m is produced by adding m times the basic angular count.

While the counter must go through all significant positions for the samples at each channel, corresponding to one-half cycle for the argument at the lowest frequency $\omega_1 = 1/2$ it is important that significant bits can be accumulated for data points within a sample, measuring the behavior of the different antennas.

Dependent on the W3-bit of the program a \cos^2 function is produced on the Log Trig card too, for weighting the data samples. Also the scaling, dependent on W3, the number of integrated pulses N and the number of samples per pulse (W2) is performed on this card, see Table 3.5.

To permit the same look-up table for the sine and cosine functions two argument functions are actually created, 90° apart. The same binary log sine table (Table 3.6) is used for the trigonometric as well as for the Hanning weighting. As Figure 3.4 shows, the full period of the argument is divided into four quadrants, determined by the two highest bits of the argument. To avoid errors in the production of the trigonometric function all 12 bits of the timing function are added. The sine and cosine output of the Sine Table can be independently read if $B = 2$ and $Z = 0$ to 7 or 8 to F.

Hanning weighting reduces the $\frac{\sin x}{x}$ ringing caused by the limited sample length. The weighted sequence decreases the leakage

N	Double Sampling	Hanning	Pulses	Samples	Weight	Scaling [6 dB]
1	0	+	4	-	-	-
	+	+		-	-	-
	0	0		-	-	-
	+	0		8	F	0
2	0	+	8	-	-	-
	+	+		16	H	0
	0	0		8	F	0
	+	0		16		-1
3	0	+	16	16	H	0
	+	+		32	F	-1
	0	0		16		-1
	+	0		32	-2	
4	0	+	32	32	H	-1
	+	+		64	F	-2
	0	0		32		-2
	+	0		64	-3	
5/9/C	0	+	64	64	H	-2
	+	+		128	F	-3
	0	0		64		-3
	+	0		128	-4	
6/A/D	0	+	128	128	H	-3
	+	+		256	F	-4
	0	0		128		-4
	+	0		256	-5	
7/B/E	0	+	256	256	H	-4
	+	+		512	F	-5
	0	0		256		-5
	+	0		512	-6	
8/F	0	+	512	512	H	-5
	+	+		1024	F	-6
	0	0		512		-6
	+	0		-	-	

DGS 256-10 LOG TRIG SCALING

8103 1201
Bi 1 Sep 81

Table 3.5

XX0	XX1	XX2	XX3	XX4	XX5	XX6	XX7	XX8	XX9	XXA	XXB	XXC	XXD	XXE	XXF
000	FFF	FFF	FFF	FFF	FFF	FFF	FFF	FFF	FFF	FFF	FFF	FFF	FFF	FFF	FFF
010	7FF	7FF	7FF	7FF	7FF	7FF	7FF	7FF	7FF	7FF	7FF	7FF	7FF	7FF	7FF
020	FFD	FFD	FFD	FFD	FFD	FFD	FFD	FFD	FFC	FFC	7FC	7FC	7FC	7FC	7FE
030	FFB	FFB	FFB	FFA	FFA	FFA	7FA	7FA	FF9	FF9	FF9	7F3	7F9	7F8	7FE
040	7F8	7F8	7F7	7F7	7F7	7F6	7F6	7F6	7F6	7F5	7F5	7F5	7F5	7F4	7FE
050	7F4	7F3	7F3	7F2	7F2	7F2	7F1	7F1	7F1	7F0	7F0	7F0	7EF	7EF	7FE
060	FEE	7EE	FED	7ED	FEC	7EC	FEB	FEB	7EB	7EA	7EA	7E9	7E9	7E8	7FE
070	FE7	FE7	FE6	7E6	FE5	7E5	FE4	7E4	FE3	7E3	7E2	7E1	7E1	7E0	7FE
080	FD7	7DF	7DE	7DD	FDC	7DC	FDB	FDA	7DA	7D9	7D9	7D8	7D7	7D6	7FE
090	FD5	7D5	FD3	FD2	7D2	7D1	FD0	7C2	7CF	7CE	7CD	7CC	7CB	7CA	7FE
0A0	7C9	7C8	7C6	7C5	7C4	7C3	7C3	7C2	7C1	7C0	7BF	7BE	7BD	7BC	7FE
0B0	7BA	7B9	7B7	7B5	7B4	7B3	7B2	7B1	7B0	7A7	7AD	7AC	7AB	7A8	7FE
0C0	7A7	7A5	7A2	7A1	79F	79E	79C	79B	799	798	796	794	792	791	7FE
0D0	F8D	F8B	F87	F85	F83	F81	77F	77D	F7A	778	776	F73	771	76E	7FE
0E0	F68	F65	F5F	F5C	F59	755	752	F4E	F4A	F46	6BE	F3D	739	734	7FE
0F0	729	723	716	F0E	F06	F0D	6F4	6E9	6DD	ECE	F06	6A9	E8E	629	7FE
100	000	629	739	6A9	6BE	FCE	6DD	6E9	6F4	EFD	F06	F0E	716	669	7FE
110	729	F2E	734	F3D	742	F46	F4A	F4E	752	F55	759	F5C	F5F	F62	7FE
120	F68	F6B	76E	F73	776	778	F7A	77D	77F	F81	F83	F85	F87	F89	7FE
130	78D	78F	791	F94	796	798	F99	79B	F9C	79E	F9F	7A1	7A2	7A4	7FE
140	7A7	7A8	7A9	7AC	FAD	FAE	7B0	7B1	7B2	7B3	7B4	7B5	7B7	7B8	7FE
150	7BA	7BB	7BC	7BE	7BF	7C0	7C1	7C2	7C3	7C4	7C5	7C5	7C6	7C7	7FE
160	7C9	7CA	7CB	FCC	FCD	7CE	7CF	7CF	FD0	7D1	7D2	7D2	7D3	7D4	7FE
170	7D5	7D6	7D7	7D8	7D9	7F9	7DA	FDA	FDB	7DC	FDC	7DD	7DE	7DE	7FE
180	7DF	7E0	7E1	7E1	7E2	7E3	7E3	7E4	7E4	7E5	7E5	7E6	7E6	7E7	7FE
190	7E7	7E8	7E9	7E9	7EA	7EA	7EB	7EB	7EB	7EC	FEC	7ED	FED	FED	7FE
1A0	FEE	7EF	FEE	7F0	7F0	7F0	7F1	7F1	7F1	7F2	7F2	7F2	7F3	7F3	7FE
1B0	7F4	7F4	7F5	7F5	7F5	7F5	7F6	7F6	7F6	7F6	7F7	7F7	7F7	7F7	7FE
1C0	7F8	7F8	7F9	7F9	7F9	7F9	7FA	7FA	7FA	7FA	7FA	7FA	7FB	7FB	7FE
1D0	7FB	7FB	7FC	7FC	7FC	7FC	7FC	7FD	7FD	7FD	7FD	7FD	7FD	7FD	7FE
1E0	7FE	7FE	7FE	7FE	7FE	7FE	7FE	7FE	7FE	7FE	7FE	7FE	7FE	7FE	7FE
1F0	7FF	7FF	7FF	7FF	7FF	7FF	7FF	7FF	7FF	7FF	7FF	7FF	7FF	7FF	7FF

(With exception of highest bit which is 3/64 dB; the first character of each number is in 24 dB, the second character in 3/2 dB and the last character in 3/32 dB.)

LOG TRIG FUNCTION IN HEXADECIMAL NOTATION

Table 3.6

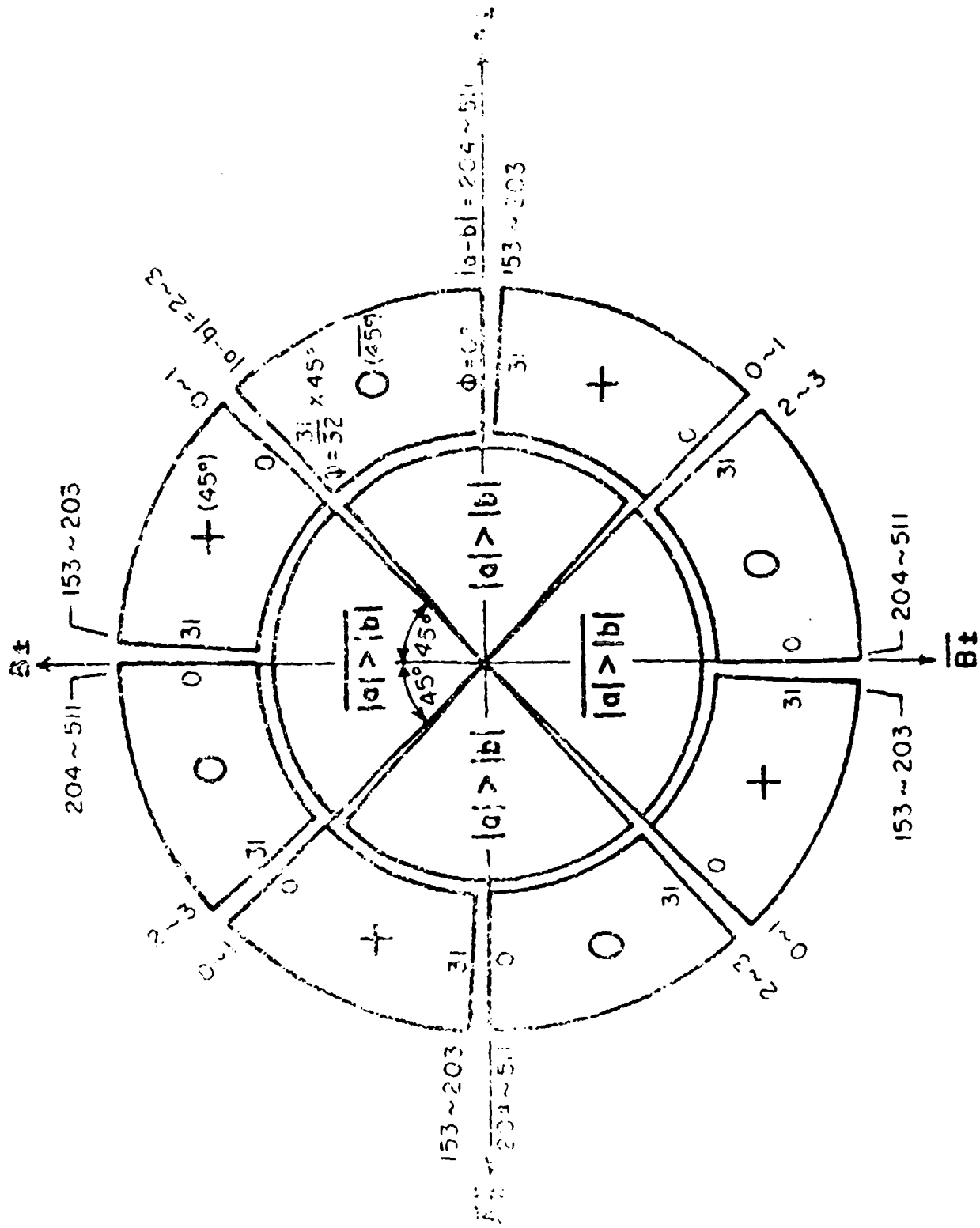

OCTANT FOR PHASE ϕ

of a sinusoidal signal, offset by one-half the spectral window, into the neighboring spectral channel from 12.7% to 2.5%.

In all practical cases it is sufficient to use Hanning weighting just for cases of $T \geq 8$ (only every second spectral line recorded). Either the basic timing function Y_n ($B = 0$) or the trigonometric argument function W_n ($B = 1$) can be fed to the display bus I_n (Table 3.9).

The logarithm C_n of the product of the trigonometric and the Hanning weights, modified by the scaling to compensate the number of integrations, is added in the Digitizer card 12 to the digitized logarithmically compressed data. The new Digitizer has a resolution of $\pm 1/2$ bit of eleven bits plus sign bit. This resolution is satisfactory even for small signals which do occur in cases of deep fadings, abnormal absorption or wrong gain settings. Thus, a signal 60 dB down from maximum still produces a significant value of 2 units. Considering the fact that up to 1024 samples can be integrated, this is adequate for spectral analysis with large dynamic range.

In the Digitizer the sine and cosine samples of the echo amplitude time functions are formed. Although a new and fast digitizer with precise sample and hold features was chosen the two samples had to be spaced $3/4$ period of the 225 kHz apart to achieve complete independence of the two samples. A common digitizer for both samples minimizes the need for precise calibration of all echo amplitudes and phases. Commanded by a double pulse chain J, minimum sampling spacing of 2.5 km can be achieved for eight or less Doppler lines computed at each range bin, while 16 Doppler lines require range spacing of 5 or 10 km. ^{If intersample phase coding} ~~double sampling~~ ($W = 2$) ^{or infinite} ~~required~~, a maximum of four Doppler lines can be computed for 2.5 km sample spacing and eight or less Doppler lines for 5 km spacing. ^{phase code are they independent}

* In the selected height gate the digital 11 bits plus sign information of the sine and cosine samples are only available for a short time at the

* Another reduction by a factor 2 is necessary if both conditions ($W=2$ and $X=1$ to 3) are chosen or $X \geq 8$ are chosen.

outputs of the digitizer and must therefore be stored in a quadruple storage register.

The Log Products Q_n , formed in the Digitizer card, are fed to the Integrator card 11 which updates the data stored in the Accumulator card 11 by adding to the stored sum of the $128 \times 8 \times 4 = 4096$ products a new product for one of the 16 channels in one of the 128 range bins.

Each 20 bit word is read out of the memory of the Accumulator card and added to the linearized Log Product from the Digitizer card. This sum is temporarily stored in 20 flip-flops and written back at the same memory address. Timing by a 24 position counter (see Figure 3.5) is optimized to accept even the slowest version of the 2114 RAM chips.

Large solid state low power storage has become available with the advent of LSI memory chips. ULCAR built one of the first operating solid-state flip-flop random access memories for the Low-Frequency Sounder (1968). For applications where reformatting of long digital data time series is necessary, the new 1024 x 4 bit per chip RAMs are ideally suited. They require almost as little power as dynamic registers and have high speed and better interface capabilities. Thus the data can be read out as a sequence of ranges for each of the 16 channels with different Dopplers and antenna configurations, while during the integration process all Doppler line products of a range bin are produced first before the ranges and the antenna configurations are changed.

The Log Sum card 15 carries out first the sum and then in a second scan the difference of two adjacent products:

- a. $- (X_n) \times \cos(\omega_{m_n} t_n) + Y_n \times \sin(\omega_{m_n} t_n)$ for the real spectral components of the positive Dopplers.

- b. $Y_n \times \cos(\omega_{m_n} t) + (-X_n) \times \sin(\omega_{m_n} t)$ for the imaginary spectral components of the positive Dopplers.
- c. $-(-X_n) \times \cos(\omega_{m_n} t) - Y_n \times \sin(\omega_{m_n} t)$ for the real spectral components of the negative Dopplers.
- d. $Y_n \times \cos(\omega_{m_n} t) - (-X_n) \times \sin(\omega_{m_n} t)$ for the imaginary spectral components of the negative Dopplers.

In order to suppress the leak-through at the mirror Doppler frequencies the sums and differences should be formed with maximum possible accuracy. For that reason 14 bits plus sign from the 20 bits of the Accumulating Memory are selected with the weights from 1 to 8192.

After logarithmic compression (see Table 3.7) the Log Sum output produces a sign bit and nine magnitude bits with 3/16 dB resolution, 0 to 95 13/16 dB. Thus more than 60 dB dynamic range for the spectral amplitudes is sufficiently covered.

On the Magnitude card 16 an algorithm, developed for the Digisonde 128 calculates from the log-real and log-imaginary components the log-magnitude and the phase. The difference in the magnitude of both components is the key to correct the larger of both log components by between 0 and 3 dB. This is shown on Table 3.8A.

Because the log-magnitude has nine significant bits, the Magnitude card has the same output format as the Log Sum card. The difference in magnitude of the log-real and log-imaginary component ($|A| - |B|$), created on the Magnitude card, also produces the phase value. Phase is presented in a 8-bit linear scale with $360^\circ : 256 = 1.40625^\circ$ resolution. Dependence of the Phase on $|A| - |B|$ and the sign of the log-real (A) and the sign of the log-imaginary (B) components is presented in Table 3.8B. The phase is alternated with the magnitude on the eight most significant bits of the Magnitude

000	00	00	00	00	01	01	02	02	02	03	03	04	04	04	05	05
010	06	06	06	07	07	08	08	09	09	0A	0A	0B	0B	0C	0C	
020	0D	0D	0E	0E	0F	0F	10	10	11	11	12	12	13	14	14	15
030	15	16	16	17	18	18	19	1A	1A	1B	1C	1C	1D	1E	1E	1F
040	1F	20	20	20	21	21	22	22	22	23	23	24	24	24	25	25
050	26	26	26	27	27	28	28	29	29	2A	2A	2B	2B	2C	2C	
060	2D	2D	2E	2E	2F	2F	30	30	31	31	32	32	33	34	34	35
070	35	36	36	37	38	38	39	3A	3A	3B	3C	3C	3D	3E	3E	3F
080	3F	40	40	40	41	41	42	42	42	43	43	44	44	44	45	45
090	46	46	46	47	47	48	48	49	49	4A	4A	4B	4B	4C	4C	
0A0	4D	4D	4E	4E	4F	4F	50	50	51	51	52	52	53	54	54	55
0B0	55	56	56	57	58	58	59	5A	5A	5B	5C	5C	5D	5E	5E	5F
0C0	5F	60	60	60	61	61	62	62	62	63	63	64	64	64	65	65
0D0	66	66	66	67	67	68	68	69	69	69	6A	6A	6B	6B	6C	6C
0E0	6D	6D	6E	6E	6F	6F	70	70	71	71	72	72	73	74	74	75
0F0	75	76	76	77	78	78	79	7A	7A	7B	7C	7C	7D	7E	7E	7F
100	7F	80	80	80	81	81	82	82	82	83	83	84	84	84	85	85
110	86	86	86	87	87	88	88	89	89	89	8A	8A	8B	8B	8C	8C
120	8D	8D	8E	8E	8F	8F	90	90	91	91	92	92	93	94	94	95
130	95	96	96	97	98	98	99	9A	9A	9B	9C	9C	9D	9E	9E	9F
140	9F	A0	A0	A0	A1	A1	A2	A2	A2	A3	A3	A4	A4	A4	A5	A5
150	A6	A6	A6	A7	A7	A8	A8	A9	A9	A9	AA	AA	AB	AB	AC	AC
160	AD	AD	AE	AE	AF	AF	B0	B0	B1	B1	B2	E2	B3	B4	B4	B5
170	B5	B6	B6	B7	B8	B8	B9	BA	BA	BB	BC	BC	BD	BE	BE	BF
180	BF	C0	C0	C0	C1	C1	C2	C2	C2	C3	C3	C4	C4	C4	C5	C5
190	C6	C6	C6	C7	C7	C8	C8	C9	C9	C9	CA	CA	CB	CB	CC	CC
1A0	CD	CD	CE	CE	CF	CF	D0	D0	D1	D1	D2	D2	D3	D4	D4	D5
1B0	D5	D6	D6	D7	D8	D8	D9	DA	DA	DB	DC	DC	DD	DE	DE	DF
1C0	DF	E0	E0	E0	E1	E1	E2	E2	E2	E3	E3	E4	E4	E4	E5	E5
1D0	E6	E6	E6	E7	E7	E8	E8	E9	E9	E9	EA	EA	EB	EB	EC	EC
1E0	ED	ED	EE	EE	EF	EF	F0	F0	F1	F1	F2	F2	F3	F4	F4	F5
1F0	F5	F6	F6	F7	F8	F8	F9	FA	FA	FB	FC	FC	FD	FE	FE	FF
200	FF	FF	FF	FF	FF	FF	FF	FF	FF	FF	FF	FF	FF	FF	FF	FF
to																
320	FF	FF	FF	FF	FF	FF	FF	FF	FF	FF	FF	FF	FF	FF	FF	FF
3C0	00	00	01	02	03	04	04	05	06	07	08	09	0A	0B	0C	
3D0	0D	0E	0F	10	11	12	14	15	16	17	18	1A	1B	1C	1E	1F
3E0	20	22	24	25	27	29	2A	2C	2E	30	32	35	37	3A	3C	3F
3F0	42	45	49	4C	50	55	5A	5F	65	6C	75	7F	8C	9F	BF	FF

Addresses of 7643 PROM: $\bar{A}_9 \bar{A}_8 \bar{A}_7 \bar{A}_6 \bar{A}_5 \bar{A}_4 \bar{A}_3 \bar{A}_2 \bar{A}_1 \bar{A}_0$

Data of 7643 (SH·SL): \bar{S} (two hex)

$$\bar{S} = 191 - 32 \log_2 (63 - \bar{A}_5 \bar{A}_4 \bar{A}_3 \bar{A}_2 \bar{A}_1 \bar{A}_0),$$

$$\text{if } \bar{A}_9 = 1 \text{ and } \bar{A}_8 \cdot \bar{A}_7 \cdot \bar{A}_6 = 1$$

$$\bar{S} = \text{FF (Hex)}, \text{ if } \bar{A}_9 = 1 \text{ and } \bar{A}_8 \cdot \bar{A}_7 \cdot \bar{A}_6 = 0$$

$$\bar{S} = 223 - 32 [\log_2 (127 - \bar{A}_5 \bar{A}_4 \bar{A}_3 \bar{A}_2 \bar{A}_1 \bar{A}_0) - \bar{A}_8 \bar{A}_7 \bar{A}_6],$$

$$\text{if } \bar{A}_9 = 0$$

BINARY LOG TABLE

Table 3.7

$C = 16 \log_2 \left[1 + 2^{-\frac{ A - B }{16}} \right]$		$\phi = \frac{32}{45} \times \tan^{-1} 2^{-\frac{ A - B }{32}}$	
$ A - B $	$C \left(\frac{3}{16} \text{ dB} \right)$	$ A - B $	$\phi \left(\frac{45^\circ}{32} \right)$
0, 1	16	0, 1	32
2, 3	15	2, 3	31
4, 5	14	4, 5	30
6, 7	13	6, 7	29
8, 9, 10	12	8, 9, 10	28
11, 12	11	11, 12	27
13, 14, 15	10	13, 14	26
16, 17, 18	9	15, 16, 17	25
19 - 22	8	18, 19	24
23 - 25	7	20, 21, 22	23
26 - 30	6	23, 24	22
31 - 35	5	25, 26, 27	21
36 - 41	4	28, 29, 30	20
42 - 50	3	31, 32, 33	19
51 - 62	2	34, 35, 36	18
63 - 88	1	37, 38, 39	17
89 - 511	0	40, 41, 42	16
		43, 44, 45	15
		46 - 49	14
		50 - 53	13
		54 - 57	12
		58 - 61	11
		62 - 66	10
		67 - 71	9
		72 - 77	8
		78 - 84	7
		85 - 92	6
		93 - 101	5
		102 - 113	4
		114 - 128	3
		129 - 152	2
		153 - 203	1
		204 - 511	0

A = Log Real and

B = Log Imag. of Spectral Amplitudes in dB

Table 3.8. LOG MAGNITUDE CORRECTION C AND PHASE ϕ

card during the data transfer time. Thus the build-up of the magnitude alone can be displayed from the analog output CHANNEL B during integration time.

3.4 Interface Cards

The remaining four cards interface the timing and data preprocessing cards to the output computer, the oscilloscope, the analog section and to the external Antenna Switch. Either the eight highest or the eight lowest of the nine Magnitude bits are selected in the Select card 17 for the Output Computer by its own command. In addition the I_n bus can be switched to the output computer instead of the Magnitude by the 4 bit of the channel B program character B. The other bits determine the selection of the seven digital functions, Y_n , W_n , C_n , Q_n , E_n , S_n and M_n onto the I_n bus (Table 3.9). By these means the Select card also converts one of those seven functions into an analog signal to be used for an oscilloscope display at the CHANNEL B connector. With the program parameter A one of the 16 time functions (see Table 3.9 also) are fed onto the CHANNEL A output. Program parameter C selects one of the same functions onto the TRIGGER output. Storage of these program parameters and their execution takes place on the Scope Monitor card 05. Simple programming of the three oscilloscope outputs provides easy access to the important monitoring and test functions. In addition the analog IF output of the receiver can be monitored at a front panel output.

The Scope Monitor card also provides the transmitter and receiver phase sequences. The switching of the phase occurs before the beginning of the transmitter pulse. To facilitate synchronization with another Digisonde station, zero delay between transmitter and receiver phase codes is provided for delayed phase codes ($X = 5$ to 9). Because the phase code is supposed to suppress unwanted echoes from the range windows one or two pulse periods off the wanted range window, its autocorrelation is zero for the first shift (2nd window) at zero Doppler (Figure 3.6). Dependent on the number of integrated pulses and the number of interlaced antenna

Trigger C	Channel A	Channel B	Display Z4=0; Z4=1	Record Z4=0; Z4=1
0	DY1	DY1	Yn	Mn
1	RL	RL	Wn	Mn
2	BJ	BJ	Cn	Mn
3	RX	RX	Qn	Mn
4	J	J	Yn	Yn
5	EJ	EJ	Wn	Wn
6	A	A	COSn; SINn	COSn; SINn
7	RY	RY	Qn	Qn
8	TY	TY	En	Mn
9	TD	TD	Sn	Mn
A	CP	CP	Mn+; Mn-	Mn
B	FM1	FM1	AM2	Mn
C	ONE	ONE	En	En
D	ID	ID	Sn	Sn
E	DY2	DY2	Mn+; Mn-	Mn
F	GT2	HY2	AM2	Mn

Top (Loop) + Fr
time
cycle
P.

Top (Loop)
time
cycle

Top (Loop)
time
cycle

DGS 256-05

81 28 Sep 81
7609 120B

Table 3.9. SCOPE MONITOR PROGRAM

1. Monitor scope on 1, A=2, B=E for point + record
2. Use either 10x magnifier or delayed sweep to show about
one pulse period

3. Add channel 2 (receiver output) to channel 1 (channel A) = 20V/cm
4. Set N.Z.T. in program 0 1 (return)

5. Set frequencies, height ranges and gains in PRI (A/B)
F1 to F4; H1 to H4 and G1 to G4

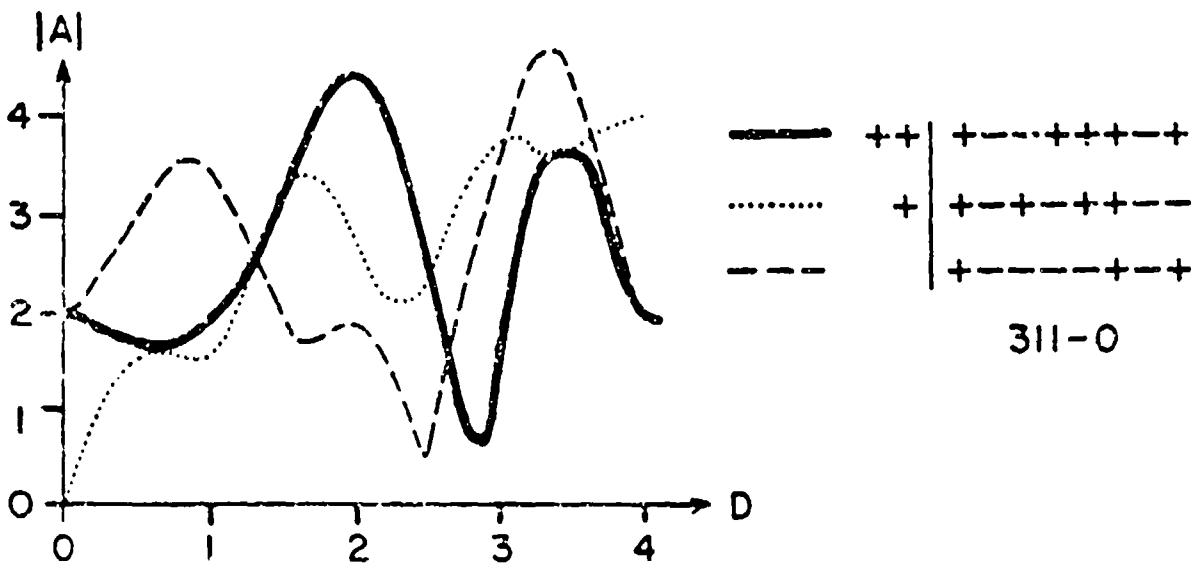
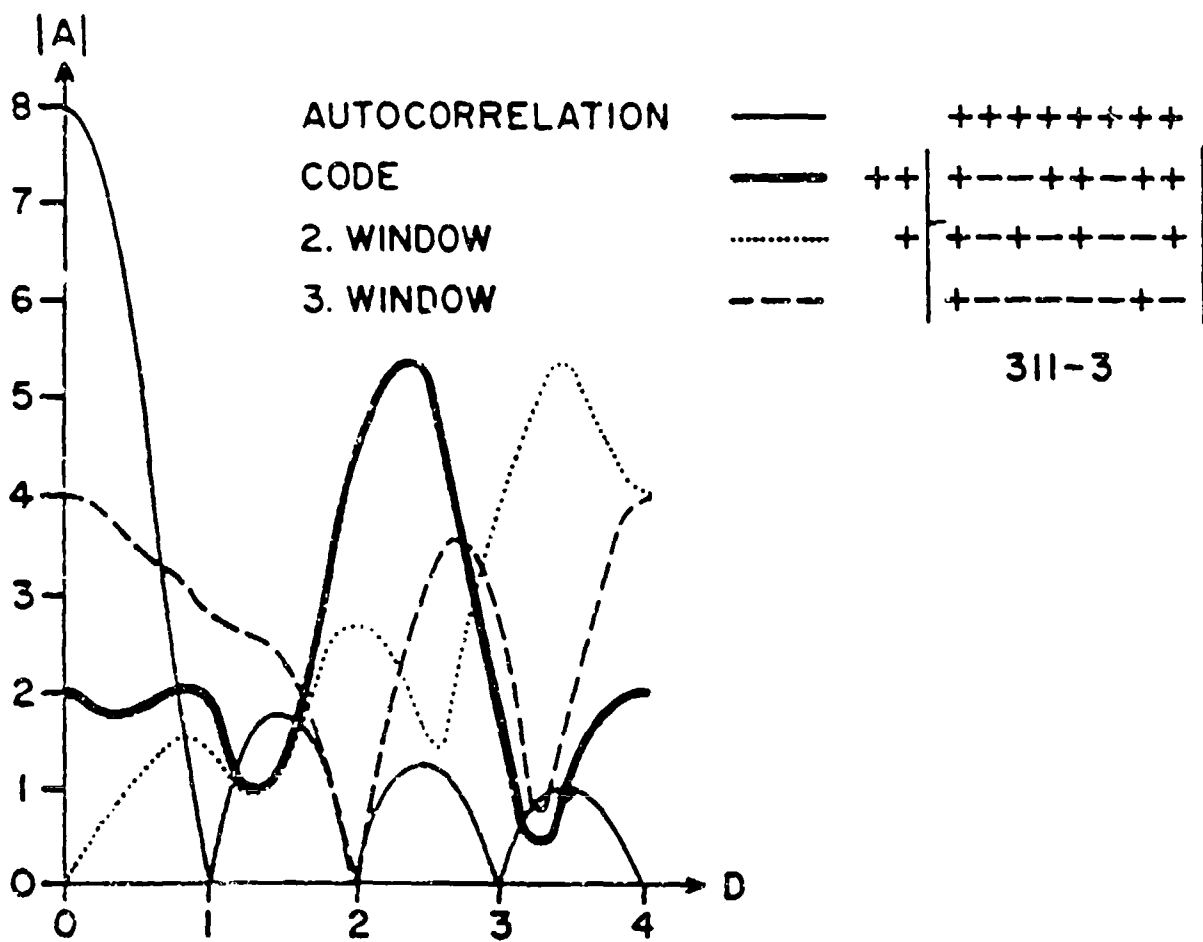

Figure 3.6. 8 PULSE PHASE CODE LEAKAGE

directions, the phase code (Table 3.10) is different from that of the earlier Digisondes because of the applied weighting during spectral integration. ~~For communication with other Digisondes the phase code in both Digisondes should be switched off.~~

A limited size of the subcodes is important if either the signal or the interference is not stationary during sampling time. Therefore, in addition to suppressing the out-of-range echoes completely, the phase code also reduces coherent interference considerably, especially if it has the same frequency or if it lies on a pulse repetition sideband of the sounding. Then almost the full coherent detection gain can be realized, bringing the effective bandwidth from 20 kHz (reciprocal pulse width) down to a combination of frequencies with individual widths in the order of 1 Hz dependent on the integration time. Because of the maximum residual values of the correlation function of the phase code (.5.0%) this is not true for all interference frequencies. The detection gain also depends on the modulation and stationarity of the interference and the number and spacing of the Doppler channels of the ^{Digitizer} Digisonde. If long range echoes (backscatter) are desired the ~~transmitter~~ ^{delayed} phase code is ~~advanced~~ and the three last prerun pulses of the remote sounder can be used for reception during spectral integration time ($X = 5$ to 7). The phase code is switched off for $X = 0$. Normal position is $X = 4$ with ~~minimum leakage for 16 or more integrated pulses.~~ ^{with zero delay between transmitter and digitizer phase code.}

On card 08 is the interface between the CORE and the Antenna Switch. This Antenna Drive card combines the timing functions B_n with the program functions L_n , Z_n and T_n . Together they provide the momentary decision of the selection of the different antennas and their delays and polarization. Table 5.8 indicates the definition of the different antennas, the beam direction and the polarizations and also the meaning of program parameter L_n as starting azimuth of an antenna sequence while Table 5.9 gives the azimuth spacing of the antenna sequence expressed by Z_n . T_n determines the number of the scanned antenna directions and the use of the overhead beam for ($T < 8$) or ($T = A, E$) x ($Z = 7$ or F).

EXTENSION FOR CLOSELY SPACED FREQUENCY MODE

The Closely Spaced Frequency Mode serves to make precise phase and group height measurement either at fixed frequency or in ionogram scanning.

In fixed frequency mode four frequencies can be freely chosen. In ionogram mode at least five frequencies, covering a one Megahertz range, are necessary ($Q = 0$).

Selecting $I = 4, 5, 6$ or 7 (see Table 5.7) four different spacings of the four closely spaced frequencies can be chosen. Originally it was planned to have the samples from four closely spaced frequencies with four Doppler lines each independently integrated. As an alternative 256 range bins with two Doppler lines each can be selected ($H \geq 8$). Both modes require $T = 2, 6, A$ or E , automatically replacing the four antenna configurations by four closely spaced frequencies.

If 128 height ranges and two Doppler lines are sufficient, two antenna configurations still can be sampled with four closely spaced frequencies for $T = 3, 7, B$ or F . The starred (*) modes of Table 5.9 will be applicable. After modification only the ordinarily polarized vertical antenna configuration is allowed for four Dopplers or 256 height ranges: $T = A$ or E and $Z = 7$ or F . For $T = 3$ or 7 and $Z = 7$ ordinary and extraordinary polarization can be sampled independently. For $T = B$ or F there are six possibilities for scanning azimuths $60^\circ, 90^\circ, \text{ or } 180^\circ$ apart either with small or large elevation angles.

On card 08 (Antenna Drive) chip 11 pin 12 has to be cut off and grounded for this extension of the closely spaced frequency modes.

B. 3 Dec 88

Code + + + + - - - + + + + + - - - + +

2. Window + + + - + - - + + + - - - + + -

3. Window + + - - + - + + - + - + + - + -

2 x Code + - - - + - - - + - + + + + - +

2 x 2. Window + - + - + - - + + + - - + - + -

2 x 3. Window + - + + - - + + + - - + + + - -

Code + + + + + + + + - - + + + + + + + + - +

2. Window + + + + + + + + - - + + + + + + + + - +

3. Window + + + + + + + + - - + + + + + + + + - -

4 x Code + - + - + - - + + - - + + + + - + + + + + + +

4 x 2. Window + - + - + - - + + - - + + + + - + + + + + -

4 x 3. Window + - + + - - + + + - - + + + + + + + + - -

Code + + + + + + + + - - + + + + + + + + - + + + + + + +

2. Window + + + + + + + + - - + + + + + + + + - + + + + + + +

3. Window + + + + + + + + - - + + + + + + + + - + + + + + + +

8 x Code + - + - + - - + + - - + + + + - - + + - + - + + + + + + +

8 x 2. Window + - + - + - - + + - - + + + + - - + + - + - + + + + + + +

8 x 3. Window + - + + - - + + + - - + + + + + + + + - 2 to 8

2 x 8, 4 x 8 AND 8 x 8 PULSE SEQUENCE CODES AND SECOND AND THIRD WINDOW CORRELATION

Table 3.10

RI 14 Dec 81

Frequency card 04 decodes and stores one or four frequencies and the program parameters I and G. It also feeds back to the input computer the momentary frequency selected in Search Mode and the actual gain selected by the Automatic Gain Control.

In drift mode the actual frequency is switched very fast between the four stored values. The stored digital values are fed to the Synthesizer cards and the Transceiver tuning in ionogram and drift mode.

3.5 Analog Cards

To facilitate testing and calibration of the digitization and data processing the analog 225 kHz signal arriving from the Sounding Transceiver can be replaced by an output of the Calibration card 40. Dividing the 12.6 MHz square wave function by $7/2$ produces 3.6 MHz. A counter to 16, preset by a phase switch, starts a 225 kHz oscillation after the beginning of the transmitter pulse. A binary switch permits a total of 16 equally spaced (11.25°) phase positions for the calibration signal. An auxiliary external attenuator improves the shape of the resulting sinusoidal signal and permits variation of the calibration signal amplitude. Additionally the phase can be changed by 180° , an external Synthesizer source can be selected and the internal source can be pulse modulated or switched off.

All frequencies are derived from a crystal controlled oscillator which has a stability of $\pm 1 \times 10^{-9}$ per day. This quartz oscillator is located on the Source card 33. In the Frequency Syntax card 34, the 16 MHz square wave is divided by 80. All seven outputs of this divider are fed as addresses to three PROM chips with five addresses plus enable each. Six of their paralleled outputs are used as phase switches for the 16 MHz square wave to create almost symmetric rectangular waves of the following frequencies: 12.6; 13.0; 13.4; 13.8; 14.2 and 14.6 MHz. Low-Q quartz filters smooth those rectangular waves to perfect sine waves of the respective frequencies.

In the Frequency Switch card 35 one of four, respectively five, frequencies from this set of six frequencies is selected for each of the four fixed frequencies F.F.0; F.F.1; F.F.2, and F.F.3. For F.F.0 one of the frequencies 12.6 to 14.2 MHz is divided by 4 and mixed with 13.4 MHz to produce 16.55 to 16.95 MHz which is divided and mixed further in the Small Steps card to produce the 5 kHz increments. For F.F.1 one of the frequencies 13.4 to 14.6 MHz is divided by 16 to produce 50 kHz increments in the oscillator frequency, for F.F.2 one of the frequencies 13.0 to 14.2 MHz is divided by four to produce the 200 kHz increments and for F.F.3 one of the five frequencies between 13.0 and 14.6 MHz is selected unchanged to produce the 800 kHz increments for the oscillator frequencies between 14.1 and 18.1 MHz.

On the Small Steps card 36 steps of 5 kHz are created by dividing F.F.0 by 5 producing 3.31 and 3.39 MHz. One of those frequencies is mixed with either 8.0 or 8.1 MHz. The latter is produced by mixing 13.0/2 with 16.0/10 MHz. The sum of F.F.0/5 and 8.0 or 8.1 MHz, covering the range from 11.31 to 11.49 MHz (see Figure 3.7) is divided by eight to produce one of the frequencies between 1.41375 and 1.43625 in 2.5 kHz increments. As Figure 3.7 shows, this frequency is first mixed with F.F.1 and then their filtered sum with F.F.2 on the Frequency Synthesizer card 41.

On the Tuning card 42 the filtered output of the Frequency Synthesizer card 28 is mixed with F.F.3. The difference frequency is filtered in two digitally tuned circuits with 0.1 MHz increments, commanded by a PROM. This tuned frequency in the range from 7.05 to 9.05 MHz is doubled on the Oscillator card 43 after mixing with either 10, 12, 14, 16, 18, 20, 22 or 24 MHz to produce the tracking oscillator 34.1 MHz higher than the desired radio frequency (RF). To obtain the transmitter frequency, this tracking oscillator frequency is mixed with a fixed frequency pulsed oscillator of 34.1 MHz, generated on the Small Steps card as the mixing product of 8.1 and the harmonic of 13.0 MHz. *The 34.1 MHz pulsed oscillator is phase switched between 0° and 180° with the quasi-random phase sequence code. For W=2 two different phase codes are applied for the first and the second half of the transmitter pulse.*

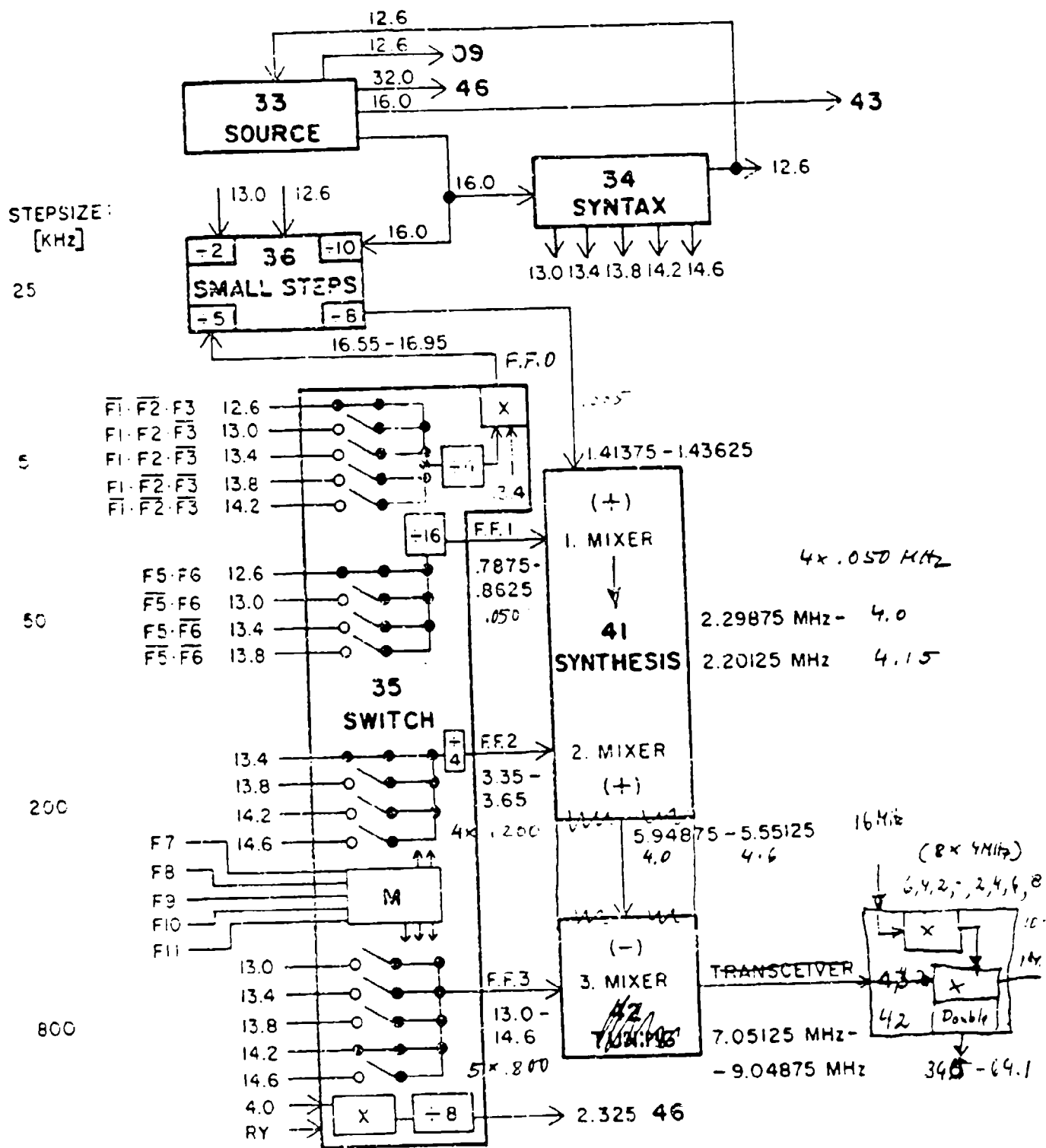

Figure 3.7. FREQUENCY SYNTHESIS

The difference frequency is filtered by digitally tuned circuits in two stages of the two RF Transceiver cards covering the frequency bands 0.5 to 4.0 (RFOONE = 44) and 4.0 to 30.0 MHz (RFTWO = 45).

The receiver consists of three cards, each of which is contained in a separate shielded compartment. There are two RF boards, ~~44~~ ⁴⁴ and ~~45~~, for the frequency bands: 0.5 to 4.0 and 4.0 to 30.0 MHz and one Intermediate Frequency (IF) board 46. In the RF boards the received signal is filtered in the same two digitally tuned stages used also for tuning of the pulsed transmitter signal.

Frequency conversion generates the first IF of 34.1 MHz, which is amplified and mixed with 32.0 MHz to produce 2.1 MHz and then converted to the final IF of 225 kHz with a third oscillator of 2.325 MHz. ~~The phase of the local oscillator in this third conversion is switched from 0° to 180° in synchronization with the pseudo-random phase coding of the transmitted RF.~~ The frequency converters use double balanced crystal mixers and all circuitry is solid state.

The overall plan of the tuned receiver, seen in Figure 3.8, shows all tuned circuits. Each of the RF boards has twin variable capacitive tuning over its frequency range, providing a constant bandwidth for each band by a specially developed series resonance circuit. The bandwidth is about 300 kHz at the low band of 0.5 to 4.0 MHz and about 900 kHz at the high band of 4 to 30 MHz.

Each tuned circuit of the IF stages has a bandwidth of approximately 70 kHz. The large number of IF circuits gives the system an overall distributed bandwidth of 20 kHz and ensures a minimum of pulse distortion.

The pulse receiver is designed for a dynamic range of 60 dB for the signal and allows for an additional 20 dB of interference (within the 300 to 900 kHz RF bandwidth) before the first balanced mixer starts to saturate. The 225 kHz IF is fed to the memory for 12 bit digitization and digital synchronous detection.

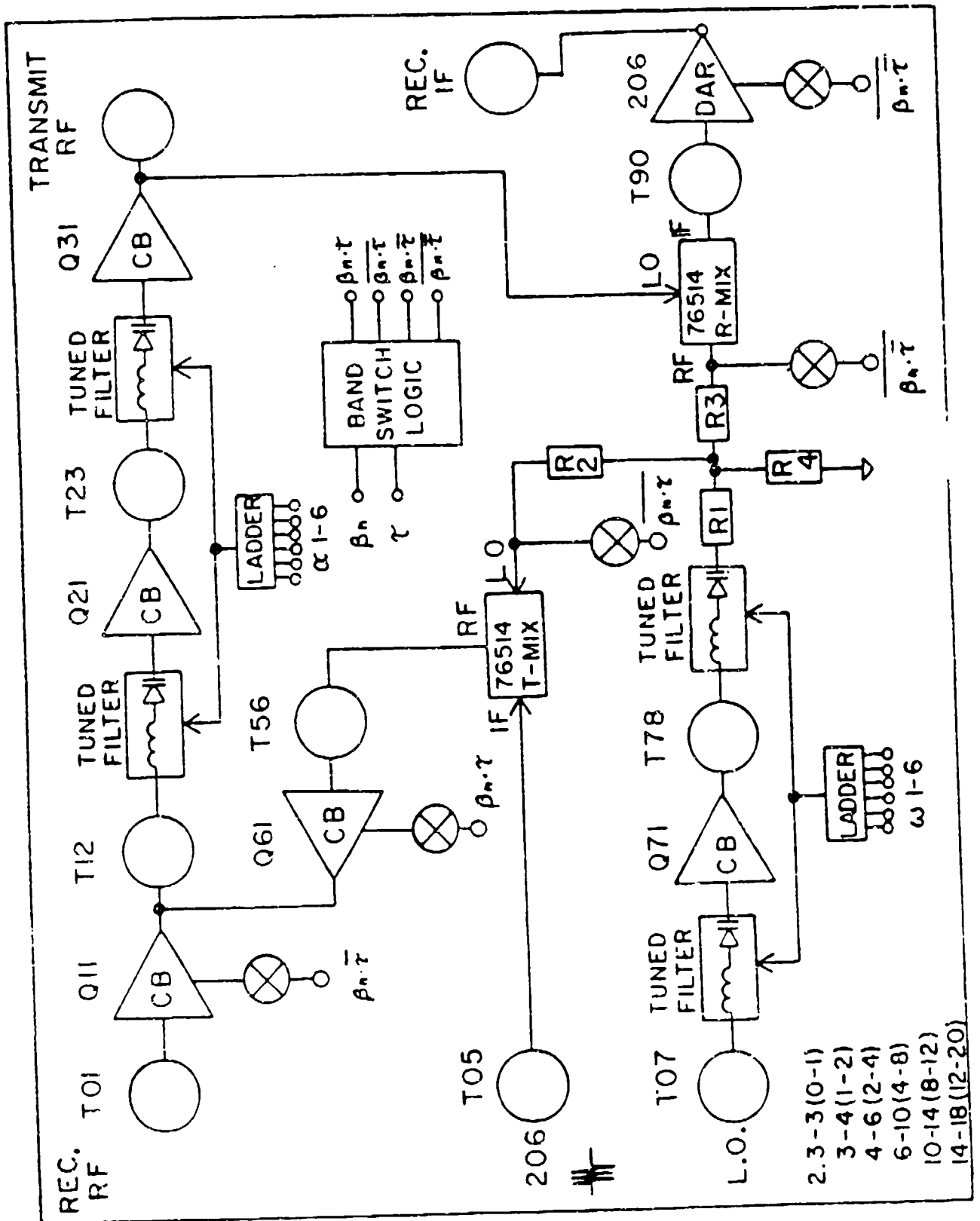

Figure 3.8. RF TRANSCEIVER

7401 0302

Receiver gain is selectable in 6 dB steps by programming parameter G from 0 to 7 for 0 to 42 dB attenuation (Table 5.5). Gain changes for morning, day, evening and night are automatically added. Resulting gain values, between 0 and 42 dB, are recorded on magnetic tape in the preface of each record. In addition, a 42 dB minimum dynamic range of signals can be recorded in 3 dB increments for each frequency with a reference level of 0 to 42 dB in 6 dB increments chosen independently for each frequency by automatic scaling of the output data maximum to the highest or second highest number (numbers 14 or 15 in printout) and printing the log of the scaling factor in 6 dB increments in front of every data line. Higher precision ($3/\delta$ dB) can be obtained by recording all 8 amplitudes ~~bits~~,
 $\propto 1/4$

The functional structure of the translator is essentially the inverse of that of the receiver; but the tuning circuits of the receiver are also used to filter the synthesized transmitter frequency. A phase-coded 34.1 MHz pulse keyed oscillator frequency is sent to the RF boards. This signal is mixed with the variable oscillator to generate a linear sweep from 0.5 MHz to 30 MHz in selectable steps of 5, 10, 25, 50, 100 and 200 kHz increments. A wide-band transformer is used in combining all RF channels into a single output which drives a linear final amplifier system. The translator provides a 0.1 Vrms signal into a 50 Ω load.

3.6 Output Computer

Postprocessing and interfacing to on-line or remote recording peripherals is the task of the Output Computer (OUTCO) which consists of nine printed circuit cards in positions 18 through 26. The integrated spectral data are transferred from CORE on bus U_1 ... U_8 via CORE DMA (direct-memory-access) card 18 to OUTCO. The data are filtered and sorted depending on the mode of operation (ionogram or drift) and stored in the Remote DMA Card 19, the Print DMA cards 20 and the Tape DMA card 21 for transfer to the dot printers and the 9-track tape drive. Display card 23 drives the plasma display or the recording oscilloscope. Control of the tape drive is executed from output ports of the Tape I/O card 22 and the

I/O Strobe card 26 which also decodes other strobe pulses for the printer and the display.

The Memory Out card 24 and the Output CPU card 25 are the same as those of the input computer, but contain different firmware. By exchanging the memory chips they could be used to test the input computer.

3.6.1 Processing of Ionogram Data

CORE outputs 16 data channels at a clock rate of 500 kHz for each transmitted ionogram frequency. Each data channel contains 128 amplitude and 128 phase bytes (8 bits each), representing the complex amplitudes for 128 height ranges. The nature of the data channels is determined by the ionogram program. An example of a useful channel distribution would be eight channels each for the ordinary and the extraordinary wave polarization, with eight Doppler lines for each polarization. Frequently, two channels will be linked together to form an array of 256 height ranges (hence the name Digisonde 256), still allowing to monitor eight different parameters (polarization, Doppler, incidence angle).

For routine operation it is impractical to record all 16 channels, i.e. 4K bytes requiring 2.56" of magnetic tape for each frequency. Only about 90 full information ionograms with 120 frequencies each can be recorded on a 2400' tape. In this "dump" mode, provided for special investigations, the complete data are recorded on magnetic tape and/or the printer.

For many observations it suffices to collect the relevant information from the 16 channels and to form one 128 or 256 bin dual array, i.e. one amplitude and one status array. The data selection process uses the maximum method developed for the Digisonde 128PS. For each range bin the channel with the largest amplitude gives the complex amplitude and the channel number to the output array. The procedure results in one multi-parameter ionogram.

This maximum method, routinely applied in the Digisonde 128PS, has the disadvantage of adding background noise to the entire range array if one or a few of the channels are noisy because of interferers. OUTCO circumvents this problem by eliminating the noisy channels before the channel intercomparison is made. The modified maximum method (MMM) goes through the following three steps:

- a) Find the most probable amplitude $A_{p,k}$ ($k =$ channel number) for each channel and calculate the average over all channels

$$A_p = \frac{1}{16} \sum_{k=1}^{16} A_{p,k} .$$

- b) Calculate the average deviation

$$\delta = \frac{1}{16} \sum_{k=1}^{16} |A_{p,k} - \bar{A}_p|$$

and eliminate channels for which $A_{p,k} \geq A_p + \delta$ by setting $A_{i,k} \equiv 0$ for all i ($i =$ range bin index) and those k values which fulfill this inequality.

- c) Within each remaining channel set $A_{i,k} = 0$ for pixels with $A_{i,k} \leq A_{p,k}$ and apply maximum method.

If $p3 \geq 8$ the noisy channel elimination is not activated

Certain types of observation may make it advisable to record double or quadruple ionograms for each ionogram sounding. Sounding from a moving platform (i.e., aircraft or spacecraft) suggests the recording of double ionograms, one with positive Dopplers, one with negative ones. If the tape recorded data are to be automatically scaled complete O and X polarization ionograms seem desirable. Many possibilities come to mind, and the necessary software can be implemented. Any of the free P1 Equal Sign commands can be used to access additional routines (Table 3.11).

3.6.2 Tape Recording of Ionogram Data

Issuing the appropriate P1 EQUAL SIGN command instructs OUTCO to format the data for the desired tape output (Table 3.11).

IONOGRAM MODE

P1 Tape Write Control

- = 0 No Write to Tape
- = 1 Standard max. method recording
- = 6 Dump all 16 channels amp + phase 1 freq/record
- = 7 Dump all 16 channels amplitudes 2 freqs/record
- = 8 Record 4 amplitudes, 4 status and 8 phases

P2 Printer Control

- = 0 No Printing
- = 2 Standard printer output amplitudes
- = 3 Phase printing - P5 < 8, Absolute Phase
P5 > or = 8, differential phase
- = 4 Amp and status for 128 range mode
- = 5 Lower range 128 amplitudes out of 256
- = 6 Upper range 128 amplitudes out of 256
- = 7 Status in 128 mode - 256 status compressed to 128
- = 8 16 channels upper bit amplitude
- = 9 16 channels lower bit amplitudes
- = 10 16 channels upper bit phases
- = 11 16 channels lower bit phases

P3 Maximum Method Options

- = 0 No birdie, no channel toss-out, no ARTIST, no film
- = 1 bit Birdie removal (1, 3, 5, 7, 9, 11, 13, 15)
- = 2 bit Channel toss-out (2, 3, 6, 7, 10, 11, 14, 15)
- = 14-15 show channels tossed out on rt side of iono
- = 8 bit ARTIST output (without 14 and 15)
- = 4 bit 4, 5, 6, 7, 12, 13, 14, 15 Film output with 10 sec
delayed start

P4 Printer Cleaning Threshold

- = 0 No Cleaning
- = 1 + 3 Increasing levels of cleaning

P5 Printer Gain Level

- = 0 prints upper 4 bits of amplitude
- = 1 to 7 prints upper 5 bits of amplitude starting at P5

DRIFT MODE

Phase will be upper 4 bits

- P2 = 0 No printing
- P2 = 1, 2, 3, 4 All antennas for freq 1, 2, 3, or 4
- P2 = 5 All frequencies for antenna = P3

Phase will be middle 4 bits

- P2 = 6, 7, 8, 9 All antennas for freq 1, 2, 3, or 4
- P2 = 10 All frequencies for antenna = P3

Phase will be lower 4 bits

- P2 = 11, 12, 13, 14 All antennas for freq 1, 2, 3, or 4
- P2 = 15 All frequencies for antenna = P3

P6 is explained on page 96C

OUTPUT PROGRAM GENERAL

8402 1600
DK rev Bi 21 Feb 85

10 Dec 83 DFK

P3

P3	BIRDIE REMOVAL	CHANNEL LOSS - OUT	CHANNEL LOSS CHANNEL OUT DISP.	ARTIST OUTPUT	FILM OUTPUT
0	0	0	0	0	0
1	1	0	0	0	0
2	0	1	0	0	0
3	1	1	0	0	0
4	0	0	0	0	1
5	1	0	0	0	1
6	0	1	0	0	1
7	1	1	0	0	1
8	0	0	0	1	0
9	1	0	0	1	0
10	0	1	0	1	0
11	1	1	0	1	0
12	0	0	0	1	1
13	1	0	0	1	1
14	0	1	1	0	1
15	1	1	1	0	1

57 02 10 83

58.1

OC OBJ

LINE SOURCE STATEMENT

```

944 : TAPE RECORDING CONTROL P1
945 :
946 : P1      128 RANGES  H(8      256 RANGES H )= 8
947 : -----
948 : 0      NO RECORDING
949 :
950 : 1      MMM  1 GROUP 4A 4S      MMM 2 GROUPS 5A 3S
951 :                LOW  HIGH
952 :      DELAR 1111111111111111  DELAR 1212121212121212
953 :
954 : 2      MMM  2 GROUPS 5A 3S      MMM 4 GROUPS
955 :                +      -      LOW+HIGH+LOW-HIGH-
956 :      DELAR 1111111222222222  DELAR 1212121248484848
957 :
958 : 3      MMM  2 GROUPS 5A 3S      MMM 4 GROUPS
959 :                0      X      LOW 0 HIGH 0 LOW X HIGH X
960 :      T=0,4      0
961 :      T=1,5 2222111122221111  48481212 REPEAT
962 :      T=2,6 0000221100002211  00004812 REPEAT
963 :      T=3,7 0000002100000021  0
964 :
965 : 4      MMM  4 GROUPS 8A 404S
966 :                +0 +X -0 -X
967 :      T=0,4      0
968 :      T=1,5 2222111188884444
969 :      T=2,6 0000221100008844
970 :      T=3,7 0000002100000084
971 :
972 : 5      MMM  1 GROUP 8A 404S
973 :      DELAR 1111111111111111
974 :
975 : 6      DUMP ALL 8A 80
976 : 7      DUMP AMPL 8A
977 : 8      MMM 1 Group 4A 4S 80
978 : 9      MMM  1 GROUP 4A 4S      MMM 2 GROUPS  LOW HIGH
979 :      DELAR 1111111111111111  COMPARED  A0 IF A0)=A1
980 :                                OR A1 IF A1)A0
981 :                                4A  EVEN
982 :                                ODD      3S
983 :
984 : AFTER CALLING SUBROUTINE 'MMM'. DATA ORGANIZATION:
985 :
986 :      AMPLI  1      AMPLI  2
987 :      STATUS 1      STATUS 2
988 :      AMPLI  3      AMPLI  4
989 :      STATUS 3      STATUS 4
990 : -----
991 : $EJECT
  
```

58B

The channel number is referred to as status. Commands P1 = 0 to P1 = 4 are preprogrammed, while 5 to 15 can be specified by the user. Recording format P1 = 1 is considered the routine format and is stored as default value. Approximately 2000 ionograms (128 range bins/frequency and 120 frequencies/ionogram) can be stored on a 2400' tape in the P1 = 1 mode. For quarter-hour ionograms this corresponds to one tape every 20 days.

The record length is fixed at 4K bytes, i.e. 4096 x 8 bits; odd parity is used. The data are coded in binary format, the preface and the header in BCD format. The record format for the routine MMM mode (P1 = 1) is shown in Table 3.12a. A 76-byte preface precedes 30 data arrays representing either 30 sounding frequencies with 128 range bins or 15 frequencies with 256 bins. Each array of 128 bytes has a 6 byte header: four digits give the frequency in kHz (the tens of MHz are given in the main preface), one byte for the gain, and one byte for the units of seconds.

The record format for P1 = 2 is similar, except two arrays of (6 + 128) bytes each are provided for each sounding frequency, the first array containing the amplitudes, the second the phase and the status (Table 3.12b). For ionograms with 256 range bins per frequency, only seven frequencies are contained in one record, and the last two arrays in the record are dummies.

The record format for the dump modes, P1 = 3 and 4, is shown in Tables 3.12c and d. In the first 76 bytes the preface is written replacing the lowest four bits of the data. The ionogram preface, written in BCD format, is explained in Table 3.13.

3.6.3 Printing of Ionograms

The on-line thermal plotter is controlled by the EQUAL SIGN command P2. The plotter is used as a printer by generating character patterns in OUTCO, either the conventional alpha-numeric font, or the patented (Bibl. 1974), optically weighted font (Optifont) which was developed especially for the Digisonde ionograms

Preface	F1	F2	F30	Total/ Record
76	6 + 128	6 + 128	6 + 128	4096

Table 3.12a. Record Format on Magnetic Tape for P1 = 1 (Routine MFM)

Preface	F1 Ampl.	F1 Ph.+Stat.	F15 Ampl.	F15 Ph.+Stat.	Total/ Record
76	6 + 128	6 + 128	6 + 128	6 + 128	4096

Table 3.12b. Record Format on Magnetic Tape for P1 = 2

Ch.1 F1 Ampl.	Ch.1 F1 Phase	Ch.2 F1 Ampl.	Ch.2 F1 Phase	Ch.16 F1 Ampl.	Ch.16 F1 Phase	Total/ Record
128*	128	128	128	128	128	4096

Table 3.12c. Record Format on Magnetic Tape for P1 = 3

Ch.1 F1 Ampl.	Ch.2 F1 Ampl.	Ch.16 F1	Ch.1 F2	Ch.16 F2	Total/ Record
128*	128	128	128	128	4096

Table 3.12d. Record Format on Magnetic Tape for P1 = 4

Byte	Symbol	Function
1 - 3	V	Station Identifier
4 - 5	Y	Year
6 - 8	D	Day
9 - 10	H	Hour
11 - 12	M	Minute
13 - 14	S	Second
15	S8	1/8 Second
16	P	Program Type
17	S	Program Set
18	X	Phase Code
19	L	Antenna Azimuth
20	Z	Antenna Scan
21	T	Doppler/Antenna
22	N	# of Samples
23	R	Rep. Rate
24	W	Pulse Width/Code
25	K	Time Control
26	I	Freq. Correction
27	G	Actual Gain
28	H	Range Increment
29	E	Range Start
30	I	Freq. Search
31	G	Preset Gain (-6 dB)
32 - 38	P	Output Controls
39 - 43	D	Diagnostics

Table 3.13a. PREFACE FOR TAPE RECORDING

Byte	Symbol	Function
*44 - 49	F	Frequency (100 Hz)
*50 - 51	B	Begin Frequency (MHz)
* 52	<u>Q</u>	Frequency Increments
*53 - 54	E	End Frequency
*55 - 57	CAB	Trigger/Display
*58 - 76	D	Diagnostics
+44 - 47	F1	Frequency 1 (10 kHz)
+48 - 51	F2	Frequency 2 (10 kHz)
+52 - 55	F3	Frequency 3
+56 - 59	F4	Frequency 4 (10 kHz)
+60 - 62	H1	Range 1 (1 km)
+ 63	G1	Gain 1 (-6 dB)
+64 - 66	H2	Range 2
+ 67	G2	Gain 2
+68 - 70	H3	Range 3
+ 71	G3	Gain 3
+72 - 74	H4	Range 4
+ 75	G4	Gain 4
+ 76	D	Diagnostic

*Ionogram only

+Drift only

Table 3.13b. PREFACE FOR TAPE RECORDING (Continued)

(Patenaude et al, 1970). A sample ionogram is shown in Figure 3.9. The amplitude values are given for 128 height ranges, and each data array is preceded by the header containing frequency, receiver gain, the units of the seconds, and the printing gain. If the full Optifont, based on a 6 x 4 matrix, is used only 128 pixels can be displayed across the page. Table 3.14 shows the different printing formats that are provided. The * indicates proposed formats for which no software is available yet.

The signal amplitudes are printed in multiples of 3 dB. The sixteen levels of the Optifont cover a dynamic range of 45 dB. The "printing gain", shown at the beginning of each data line, has been subtracted from all amplitude values, so that the largest amplitudes are not exceeding the value 45 dB, printed as a 15. The 16 level printing gain is also given in multiples of 3 dB, assuring a total dynamic range of 90 dB.

Any blank pixel in the amplitude ionogram has a corresponding blank pixel in the status ionogram. Dynamic cleaning could be applied prior to printing the array by setting an amplitude threshold equal to the most probable amplitude.

3.6.4 Tape Recording of Drift Data

At the end of each drift measurement CORE transfers a number of Doppler spectra to CORE DMA card 18. The number of channels is controlled by drift preface character L (see Table 5.11) and can vary from 2 (L = 0) to 32 (L = B). The number of spectral lines per channel can vary from 32 to 256 (Table 5.11). Each spectral line $S_{h,d,a,s}$ consists of 2 bytes, one for the amplitude, one for the phase. The total number of bytes per case will be between 128 and 4096. The sequence of the indices of $S_{h,d,a,s}$ gives the multiplexing order for the different channel. The indices h, d, a and s indicate height range, Doppler, antenna and sign. For routine drift observations one might use four antennas, two frequencies and two height ranges, i.e. 16 channels. Assuming 128 spectral lines in each channel the data format would be as follows:

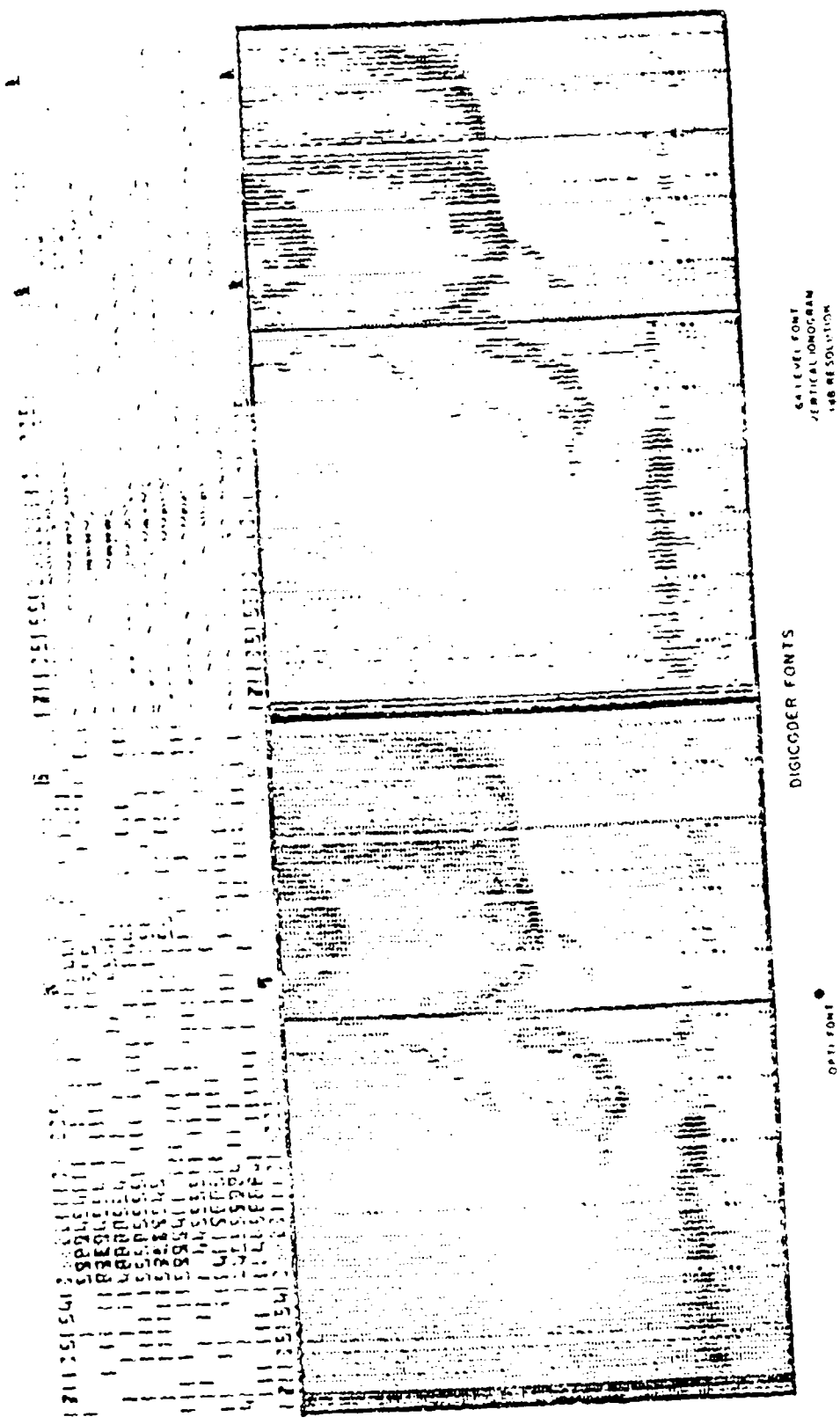

Figure 3.9

P2 =	128 Range Bins	256 Range Bins
0	No Printing	No Printing
1*	MMM, 128 Ampl. (cleaning)	MMM, 128 Ampl., 2 bins merged (cleaning)
2	MMM, 128 Ampl.	MMM, 128 Ampl., 2 bins merged
3*	MMM, 64 Ampl. (cleaning) 64 Stat.	MMM, first 128 Amplitudes (cleaning)
4	MMM, 64 Ampl. 64 Stat.	MMM, first 128 Amplitudes
5*	1. Channel, 128 Ampl.	MMM, second 128 Ampl. (cleaning)
6	2. Channel, 128 Ampl.	MMM, second 128 Ampl.
7	MMM, 128 Status	MMM, 128 Stat., 2 bins merged
8/9	Dump: 16 lines of 128 Amplitudes (3/8 dB, i.e. lower 4 bits)	
8/8	Dump: 16 lines of 128 Amplitudes (6 dB), i.e. upper 4 bits	
10*	Dump: 16 lines of 128 Phases (lower 4 bits)	
11*	Dump: 16 lines of 128 Phases (upper 4 bits)	
12*		
13*	Small font, 2 x 6 matrix, 256 pixels	
14*		
15*		

IONOGRAM ON-LINE PRINTING

Table 3.14

$S_{1,1,1,+}$	$S_{2,1,1,+}$	$S_{1,2,1,+}$	$S_{2,2,1,+}$...	$S_{2,128,1,+}$	(Ant. 1,+)
$S_{1,1,2,+}$	$S_{2,1,2,+}$	$S_{2,128,2,+}$	(Ant. 2,+)
.						
.						
$S_{1,1,4,+}$	$S_{2,128,4,+}$	(Ant. 4,+)
$S_{1,1,1,-}$	$S_{2,1,1,-}$	(Ant. 1,-)
.						
.						
$S_{1,1,4,-}$	$S_{2,128,4,-}$	(Ant. 4,-)

This data array consists of 4096 bytes. The last two Doppler lines in each channel are not recorded on magnetic tape freeing 128 bytes for storage of the drift preface. Suppression of the last two Dopplers provides sufficient space when the number of channels is 8, 16 or 32. This covers all drift programs except $L = 0$ and 8 (see Table 5.11). The number of cases per record increases with decreasing number of Doppler lines or channels.

For $L = 0$ and 8, preface space is provided by recording one case less than optimally possible within one record. Only one preface, belonging to the first case, per record is given. The drift preface is explained in Table 3.13.

3.6.5 Realtime Printing of Drift Spectra

For each drift case the spectrum (magnitudes) of one channel can be printed as one line, containing up to a maximum of 120 spectral components (60 negative and 60 positive Dopplers). This allows to print a header containing frequency (4 bytes, 10 kHz increments), range (3 bytes, 1 km increments), receiver gain (1 byte), print commands (3 bytes), seconds (2 bytes) and printing gain (2 bytes in 3 dB steps, see ionogram printing). A complete preface is printed after every ten spectra.

EQUAL SIGN command P3 selects the channel number. Commands P4 and P5, explained in Table 3.15, select the Doppler interval and the amplitude/phase resolutions.

P4 =	Doppler Interval	Doppler Spacing
0		
1	- 60 to + 60	1
2	-120 to +120	2
3	-240 to +240	4
4	-240 to -121	1
5	-120 to - 1	1
6	+ 1 to 120	1
7	+121 to 240	1

P5 =	Comments
0	No drift printout
1	Spectral Amplitudes (3 dB floating)
2	Spectral Amplitudes (6 dB, upper 4 bits)
3	Spectral Amplitudes (3/8 dB, lower 4 bits)
4	Spectral Phase (1.line: upper 4 bits 2.line: lower 4 bits 3.line: spare)
5	Dump

Table 3.15. Drift On-Line Printing

4.0 PERIPHERALS

4.1 Transmitter

Powered by a pulse forming L-C chain and triggered by a pulse train from the Digisonde, the 10 kW Final Stage amplifies the HF pulses provided by two sequential solid state wide-band drivers following the transceiver output ME of the Digisonde. The 10 kW Wide-Band Amplifier consists of three drawer chassis and the two-stage 100 Watt Solid State Amplifier mounted in the rack.

The three drawer chassis are:

Final Amplifier,
Pulse Power and
Delay Line.

4 1.1 Rack

As Figure 2.1 shows the rack also contains three fans and the main circuit breaker with two switches which are in parallel at 115V wiring and on each side of the power line at 230V AC. A strip wired for 115V AC is available at the top of the front for soldering iron and oscilloscope. There is also space for the main Digisonde 256 chassis and the Receiver Antenna Switch. If no separate receiver antenna is available, a tap on the dummy resistor of the Final Amplifier can be connected directly to the receiver input of the Digisonde 256. Four pairs of slides for the drawer chassis are also installed. A solid-state wide-band amplifier interfaces the transceiver and the Final Amplifier by BNC connector providing 100 Watt HF pulse power. Simultaneously, a negative going pulse to zero from a 24V level should be arriving on another BNC connector. Different polarity and different voltage levels can easily be accommodated.

The output is a type N connector and provides between 10 and 5 kW at a 50 Ω load. An open output will not damage the amplifier.

4.1.2 Final Amplifier

In the 0.5 to 30 MHz version the Final Amplifier consists of a distributed amplifier with two chains in push-pull of seven tubes 4CPX250K on each side. Because the modern Eimac 4CPX250K ceramic tubes have very low plate capacity they permit a relatively high plate impedance up to VHF frequencies. Therefore, the development of a high-power, high-voltage output transformer became the most important task for the design of this Final Amplifier. A (450+450):50 [Ω] impedance match was achieved with three transformers. Since the ratio of grid to plate capacitance is rather large (4:5), optimum input match is easy, namely 50:(100+100) [Ω]. The high impedance ratio of the plate and grid delay lines requires treating the delay lines as shunt m-derived low-pass filters (see Figure 4.1) and to parallel the stray capacities of the grid inductors by 5 pF in order to keep the scale factor of 4.5 for all components.

4.1.3 Pulse Power

Functionally, the Pulse Power chassis, the Delay Line, the inductor and the high power pulse transformer form the pulse power supply. In addition, there is a printed circuit card in the Pulse Power drawer which monitors the current and the bias voltage and controls the Silicon Controlled Rectifier (SCR).

The Pulse Power drawer provides up to 6 Amp of current at 230 Volts. For power lines of 230 Volt, the input windings of the three transformers can be used as auto-transformer to provide 115 Volt for the Digisonde on one-half of the windings and an opposite 115 Volts for the fans, the test and the peripheral equipment. A symmetric power consumption on the two 115 Volt branches is recommended.

Since a separate large inductor is installed to charge a capacitor of 200 μ F located in the Delay Line drawer, the power line

$$Z_{T2} = R \frac{\sqrt{1 - \omega^2/\omega_c^2}}{1 - (1 - m^2)\omega^2/\omega_c^2}; \quad L_1 = m L_k; \quad C_1 = \frac{1 - m^2}{m} C_k;$$

$$L_k = R^2 \cdot C_k; \quad \omega_c = \frac{1}{\sqrt{C_k \cdot L_k}} \quad C_2 = m C_k$$

$$\omega_c = \frac{1}{R \cdot C_k} \quad C_1/C_2 = \frac{1 - m^2}{m^2}; \quad m = \sqrt{C_2 / (C_1 + C_2)}$$

$$C_k = C_2/m = \sqrt{C_2 \cdot (C_1 + C_2)}$$

$$L_1 = R^2 \cdot C_2$$

$$f_c [\text{MHz}] = \frac{1000}{2\pi \cdot R[\text{k}\Omega] \cdot \sqrt{C_2 \cdot (C_1 + C_2)}} = 90 [\text{MHz}]$$

$$L_{1G,P} [\mu\text{Hy}] = (R[\text{k}\Omega])^2 \cdot C_{2G,P} [\text{pF}]; \quad C_{2G} = 1/2 C_G; \quad C_{2P} = 1/2 C_P$$

$$L_{1P} = 0.45^2 \cdot 3 = 0.6075 [\mu\text{Hy}]; \quad L_{1G} = 0.1^2 \cdot 13.5 = 0.135 [\mu\text{Hy}]$$

$$C_P = 2C_{2P} = 6 [\text{pF}]; \quad C_G = 2C_{2G} = 27 [\text{pF}]$$

$$C_{1P} = 2 [\text{pF}]$$

$$C_{1G} = 9 [\text{pF}]$$

$$m = 0.775$$

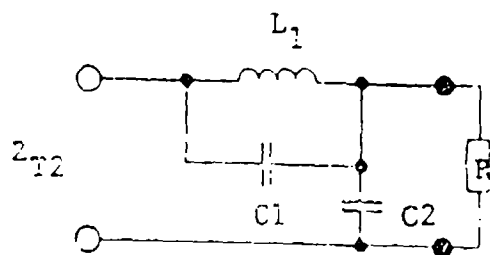

C_G and C_P are grid and plate capacitances of tube.

SHUNT M-DERIVED LOW-PASS FILTER

Figure 4.1

can provide an almost sinusoidal current and modulation of the quartz driven pulse sequence by the power line frequency is minimized.

On the Pulse Driver card an oscillator and divider chain provides a delay after a power failure, a wanted interruption, a short circuit or a surcharge. For that purpose three sensors are built in monitoring the high power current on pin 20 and the level of the negative bias. If the 10-pin connector of the Final Amplifier chassis is disconnected, i.e., if the heater of the tubes are off, then also the zener diodes in this chassis are disconnected and the bias, monitored on pin 8, becomes too large which resets the counter. If there is no bias (short circuit or blown fuse) the counter is reset also.

On pin 20 there is a negative voltage, produced by the high power current on the serial resistor of 1/2 Ohm. In case the SCR does not open, producing a current of more than 6 Amp, or the current is too high due to a short circuit in the pulse power load or at too high repetition rate, the counter is reset also. It will take two to three min before the high voltage optically coupled switch D4808 will activate again. It is advisable to switch on the manual switch on the front panel before that time.

4.1.4 Delay Line

To permit a variable pulse length of 66 and 133 μ sec, the Delay Line is composed of two chains linked by a diode and charged by independent inductors. One-half of the delay line, connected via the pulse transformers to the SCR is always charged. In addition to the delay line, the Delay Line chassis includes the pulse transformer and the SCR. The second charging inductor is switched off if a small pulse width is chosen. DC power is interrupted during switching.

The inductance of the charging inductors is small enough to almost charge the delay line to the peak even at 200 Hz repetition rate, thus derating the maximum power only little at that high repetition rate. The peak voltage is higher than twice the average

voltage measured at the charging capacitors of 200 μ F because the stray inductance of the pulse transformer provides a negative swing which is necessary to switch off the SCR.

4.1.5 Operation and Maintenance

In spite of its high peak power and large duty cycle, the 10 kW Final Amplifier is a safe device because of its very low impedance of 1.2 Ω at the input of the pulse transformer and 150 Ω at its output. Several safety features will assure a reliable operation.

To protect the expensive tubes sufficient air flow must be provided for their cooling. It is therefore necessary that the 10 kW Distributed Amplifier drawer is always pushed in fully. If testing in operation is required the drawer can just be pulled out for a short moment even if only the heaters are connected. It is advisable to remove the horizontal strip underneath the drawer if testing of the chassis bottom is desired. After the test the horizontal strip must be put in place again. It is, however, unlikely that a tube will be damaged because either the heater or the plate connection will unsolder itself and fall off before permanent damage can occur. It is therefore recommended to check the cathode currents of all tubes for equality after any equipment repair or test by turning the knob on the left side of the 10 kW chassis to its first 14 positions from the left. The indicated current depends on pulse repetition rate and excitation. Therefore, a reference table should be established at the beginning. The 15th position of the switch gives an indication of the pulse voltage times root of duty cycle.

Before bringing the 10 kW Final Amplifier into operation, all internal connections must be checked, especially the large twist-lock connection between the Pulse Power and Delay Line drawers, but also the antenna connections, the high voltage pulse connection, the fan connections and the AC power input. The latter should be twisted a full turn to the left before connection to secure the twist-lock feature even if the drawer is pulled out repeatedly.

After connecting the power of 220 to 240 Volts and the two BNC connections for the negative going trigger pulse from a +24 level to zero (0.4) Volts and the HF pulse of 3 to 9 Watts, the main breaker on the right lower corner of the rack can be activated.

It is advisable to also switch on the main switch on the Pulse Power chassis because the switching spikes of the high voltage (480 V) solid state switch in series with this manual switch can trip the delay and protection circuitry. As soon as the main power is on, a LED display shows the activation of the delay counter by blinking at about 1/2 sec rate. After 256 counts (2 to 3 minutes) the solid state relay is activated if the right bias is present and the current not excessive. For easier test of the protection functions the PC card in the Pulse Power chassis can be put on an extender card if the drawer is pulled out. The bias is fused separately with a 0.5 Amp fuse located at the far right on the front panel of the Pulse Power drawer. Its presence is indicated at the red indicator lamp next to the fuse.

If the 300V DC is activated the red lamp on the third position from the right is lit. The secondary fuse of 6 Amp is at the left of the switch which follows the indicator lamp.

If the operator is sure that the heater and the bias are correct and on sufficiently long the time delay can be overcome by pushing the push button to the left of the blinking LED. This LED will be lit permanently if the high voltage is on. (Push only if the transmitter pulses are off.)

The HF meter for the antenna current is connected between the connectors N2 and N3 by two wires of a quadrofilar cable. The remaining two wires are short-circuited near the meter. This quadrofilar cable thus forms a current transformer, creating a meter reading of slightly below one-half of the actual antenna current. If the pulse width is smaller than 100 usec the additional scaling factor is more than 10 at 100 Hz and more than 7 at 200 Hz.

To avoid destruction of the HF current meter by lightning it might be advisable to directly connect the antenna to output N1 if the antenna current need not be monitored. The Distributed Amplifier is optimized for an input power of 100W. If much less input power were available one or two of the 20 Volt zener diodes could be short-circuited in the chain of 20 Volt zeners each to decrease the bias by 20 Volts. Then the screen voltage should be decreased by replacing a 25 Ω resistor by a 50 Ω resistor in the voltage divider chain to generate the same current in the tubes as before.

To speed up diagnosis in case of a complete failure where the SCR never stays on, it is advisable to replace the high voltage connection to the 10 kW Distributed Amplifier drawer by a dummy load of a resistor of 125 to 150 Ω at 1000 Watt. If the failure persists then the pulse power supply is at fault. If the failure is gone then the 10 kW stage forms a wrong impedance. When the impedance is too low it leads to moderate overcurrent (monitor pin 20 on PC card which will show less than -2.5V but far from -8 Volts if the push button is pushed for a short moment). When the impedance is too high the SCR will not open and produce a surge current, producing -8V on pin 20. In this case the push button may be pushed only for a very short time.

This test will help to find the short or the opening in the 10 kW Final Amplifier very quickly. If the SCR has failed because of unusually high peak voltages in the AC supply it might be advisable to replace it by a C159M which will withstand higher voltages.

All the HF and Pulse Power voltages can be monitored with a 100:1; 1.5 kV oscilloscope probe, except the plate voltage. The supply voltage can be tested by measuring the voltages on both ends of the second 600 Ω resistor in the divider chain and adding to the higher voltage the difference. In testing it should be realized that the screen currents of the tubes can be negative. Although too high screen voltages may lead to low frequency oscillations, the tubes are very reliable. Their large grid capacitance decreases the feedback

by the small plate-grid capacity. Therefore, the change in phase at the grids with increasing tube number is easily observed. But it should be realized that the phase on all tube plates is the same if the impedances and the delays are well matched. Only the voltage increases with the tube number at high frequencies.

It is requested not to run the system too long without an antenna. To insure reliable operation for a long time the air filters of the fans must be cleaned periodically dependent on the dust level of the station.

4.2 Antenna Switch

In a fast moving aircraft or in a satellite the doppler measurement can be used for arrival angle measurement, at least in one dimension. But for most stations on the ground a two-dimensional antenna field is necessary to produce the information of the azimuth and elevation of the arriving signals.

An elaborate field of 25 receiving antennas had been used in the first installation of a Digisonde 128PS system on Kwajalein Island in the West Pacific. It has become, however, advisable to standardize an antenna array of two perpendicular sets of seven loop antennas which are sufficient for routine observation as well as for most scientific investigations. In the following section an antenna switch is described which powers the two amplifiers in each of the seven turnstile antennas and permits the selection of any single or the steering of all seven antennas in 12 azimuth directions and two elevations, in addition to the vertical position. The location of the seven antennas, Figure 4.2, has been selected to minimize, for a large frequency range from 3 to 12 MHz, the reception of unwanted interferers arriving from low incidence angles, in the case when a vertical beam is desired, and to minimize the number of delay lines necessary to bring all antennas in phase for any of 12 azimuth directions. Two sets of delay lines are chosen independently which have any fixed ratio to permit either two almost vertical elevations (for example: 7.5° and 15°) or one rather vertical and one low

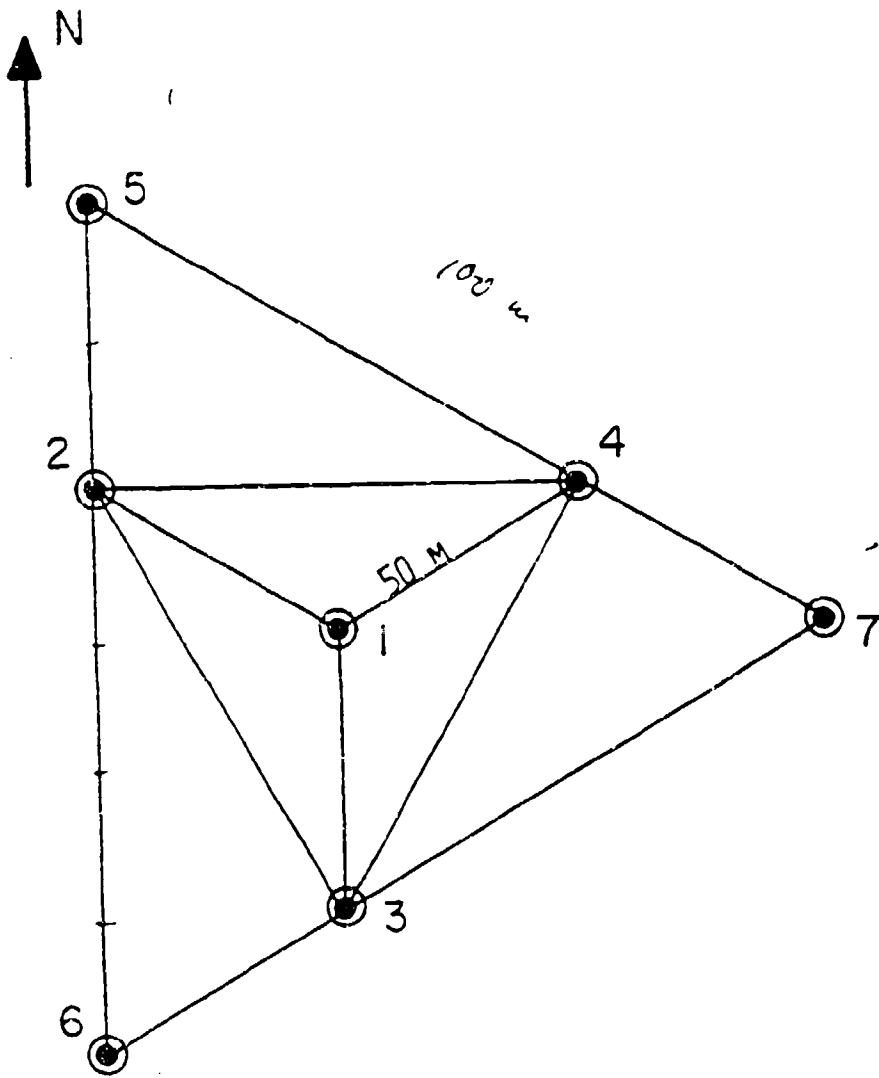

2 x 7 TURNSTILE ANTENNA LAYOUT

Figure 4.2

elevation (15° and 75°) to produce practically simultaneous vertical and oblique soundings for backscatter or bistatic experiments.

There are several choices for the combination of the two perpendicular sets of antennas to permit single use of each of the two perpendicular subarrays, linear addition or subtraction or the addition or subtraction with 90° phase shift for receiving both right-hand and left-hand circular polarization. The single use of the subarrays is indicated to measure one of the linear polarizations at the equator. For reception of low incidence angle vertically polarized signals use of a linearly polarized antenna array is recommended too, although it might be useful for some studies to alternately measure right- and left-handed polarization at low incidence angle. By taking either one of the two sets of antennas or by adding or subtracting the outputs of the two sets four forward and reverse directions can be selected with 45° spacing:

	N/S	NW/SE	W/E	SW/NE
for	N	N + W	W	W - N

if the antennas are aligned in the N/S and W/E direction. The necessary delays for the 25 locations of the antenna beam are indicated in Table 4.1 as well as the logic for the single selection of one of the seven antennas. In Table 5.9 the chosen sequence of antenna beam directions is indicated for eight values of the Z program parameters. With the L program parameter (Table 5.8) the starting azimuth of the antenna sequence can be chosen.

4.3 Realtime Ionogram Scaler

Housed in a separate chassis the realtime ionogram scaler (RIS) extracts the ordinary echo trace from the raw ionogram, determines the important ionospheric parameters and calculates the vertical electron density profile. From the 16 parameter ionogram data produced by the DGS 256 the ordinary and extraordinary polarization channels with vertical incidence are selected for the trace extraction. The methods of automatic trace identification for Digisonde ionograms

Az.	L	Ant.							A1		A3			A5			A4	
		1	2	3	4	5	6	7	61	62	60'	64	60"	61'	62'	64'	61	66
V ₀	0.0	0	0'	0'	0'	0	0	0	-	-	0	00	6	1+1x	1+1x	1+1x	-	6x
	1.0	0	00	00	00	00	00	00	-	-	0	4x	6	1+1x	1+1x	1+1x	-	6x
N ₁ N ₂	0.1	3(2)	4	1	4	6(0")	0	3(2)	0	1	0	0	0	0	0	0	0	0
	1.1	3(2)	4	1	4	6(0")	0	3(2)	1x	2x	-	4x	6	0	1+1x	0	-	6x
O ₁ O ₂	0.2	2	4	0'	2(1)	6(0")	0	0	1	0	0	0	0	0	0	0	0	0
	1.2	2	4	0'	2(1)	6(0")	0	0	1x	2x	0	4x	6	1+1x	0	0	-	6x
P ₁ P ₂	0.3	3(2)	5(4)	2(1)	2(1)	6(0")	3(2)	0	1	1	-	1	6	0	0	0	0	0
	1.3	3(2)	5(4)	2(1)	2(1)	6(0")	3(2)	0	1x	2x	-	4x	6	1+1x	1+1x	1+1x	-	6x
W ₁ W ₂	0.4	4	6(0')	4	2(1)	6(0")	6(0")	0	1	-	6	0	0	0	0	0	0	0
	1.4	4	6(0')	4	2(1)	6(0")	6(0")	0	1x	-	6	0x	6	1+1x	0	0	-	6x
X ₁ X ₂	0.5	3(2)	4	4	1	3(2)	6(0")	0	0	1	-	0	0	0	0	0	0	0
	1.5	3(2)	4	4	1	3(2)	6(0")	0	1x	2x	-	4x	6	0	1+1x	0	-	6x
Y ₁ Y ₂	0.6	2	2(1)	4	0'	0	6(0")	0	1	0	0	0	0	0	0	0	0	0
	1.6	2	2(1)	4	0'	0	6(0")	0	1x	2x	0	4x	6	1+1x	0	0	-	6x
S ₁ S ₂	0.7	3(2)	2(1)	5(4)	2(1)	0	6(0")	3(2)	1	1	-	1	6	0	0	0	0	0
	1.7	3(2)	2(1)	5(4)	2(1)	0	6(0")	3(2)	1x	2x	-	4x	6	1+1x	1+1x	1+1x	-	6x
T ₁ T ₂	0.8	4	2(1)	6(0')	4	0	6(0")	6(0")	1	-	6	0	0	0	0	0	0	0
	1.8	4	2(1)	6(0')	4	0	6(0")	6(0")	1x	-	6	0x	6	1+1x	0	0	-	6x
U ₁ U ₂	0.9	3(2)	1	4	4	0	3(2)	6(0")	0	1	-	0	0	0	0	0	0	0
	1.9	3(2)	1	4	4	0	3(2)	6(0")	1x	2x	-	4x	6	0	1+1x	0	-	6x
I ₁ I ₂	0.A	2	0'	2(1)	4	0	0	6(0")	1	0	0	0	0	0	0	0	0	0
	1.A	2	0'	2(1)	4	0	0	6(0")	1x	2x	0	4x	6	1+1x	0	0	-	6x
F ₁ F ₂	0.B	3(2)	2(1)	2(1)	5(4)	3(2)	0	6(0")	1	1	-	1	6	0	0	0	0	0
	1.B	3(2)	2(1)	2(1)	5(4)	3(2)	0	6(0")	1x	2x	-	4x	6	1+1x	1+1x	1+1x	-	6x
G ₁ G ₂	0.C	4	4	2(1)	6(0')	6(0")	0	6(0")	1	-	6	0	0	0	0	0	0	0
	1.C	4	4	2(1)	6(0')	6(0")	0	6(0")	1x	-	6	0x	6	1+1x	0	0	-	6x
L2	0.D	00	00	00	00	00	00	00	00	00	00	00	6	1+1x	1+1x	1+1x	00	6x
L3	1.D	00	00	00	00	00	00	00	00	00	00	00	6	1+1x	1+1x	1+1x	00	6x
L4	0.E	00	00	00	00	00	00	00	00	00	00	00	6	1+1x	1+1x	1+1x	00	6x
L5	1.E	00	00	00	00	00	00	00	00	00	00	00	6	1+1x	1+1x	1+1x	00	6x
L6	0.F	00	00	00	00	00	00	00	00	00	00	00	6	1+1x	1+1x	1+1x	00	6x
L7	1.F	00	00	00	00	00	00	00	00	00	00	00	6	1+1x	1+1x	1+1x	00	6x

B: 18 June 78

7801 220-3

2 - 7 ANTENNA SWITCH DGS 120PS-B

Delays

checked by B. See 84

Table 4.1 A

has been described by Reinisch et al (1981). Figure 4.3 shows the error distribution function for the autoscaled foF2 parameter based on the evaluation of 256 non-spread ionograms from January 1980, Goose Bay, Labrador. For more than 70% of the ionograms foF2 is scaled within ± 0.2 MHz of frequent occurrence of spread F. Even if the frequent cases of spread F ionograms are included (for a total number of 577) automatic scaling deviates from the manually scaled values by less than ± 0.5 MHz in 80% of all cases.

For calculation of the electron density profile RIS uses the profile-fitting method developed by Huang and Reinisch (1982) for application to autoscaled ionogram traces. A Chebysheff polynomial of order 7 or less for the F-region profile is fitted such as to reproduce the $h'(f)$ trace. The method was adapted to bottomside Digisonde ionograms by Huang Xueqin. The E-region is approximated by a parabola with peak density $N_{ME} (foE)^2$, half width Y and height h_E . A valley between E and F region is calculated which best reproduces the slope of the $h'(f)$ curve for $f > foE$. Figure 4.4 shows an automatically scaled ionogram from Goose Bay, Labrador. The little square dots mark the manual scaling.

The RIS system is based on a 8085 5BC microcomputer with a hardware mathematics processor unit. Intel's Fortran 80 is used as source language. The entire ionogram is first stored before processing begins. The output data are available for magnetic tape recording and on an RS 232 serial output port.

4.4 Magnetic Tape Drive

After many years experience ULCAR has standardized on digital tape recorders for which either separate or imbedded formatters are supplied by the manufacturer. All of the major manufacturers of digital tape drives [Pertec, Kennedy, IDT (Tandberg), Digidata, etc.] make models whose latest generation formatters would be compatible with the microcomputer (OUTCO) in the DGS 256. Several models with different reel size capabilities are available from these manufacturers. The only specific requirements for compatibility are

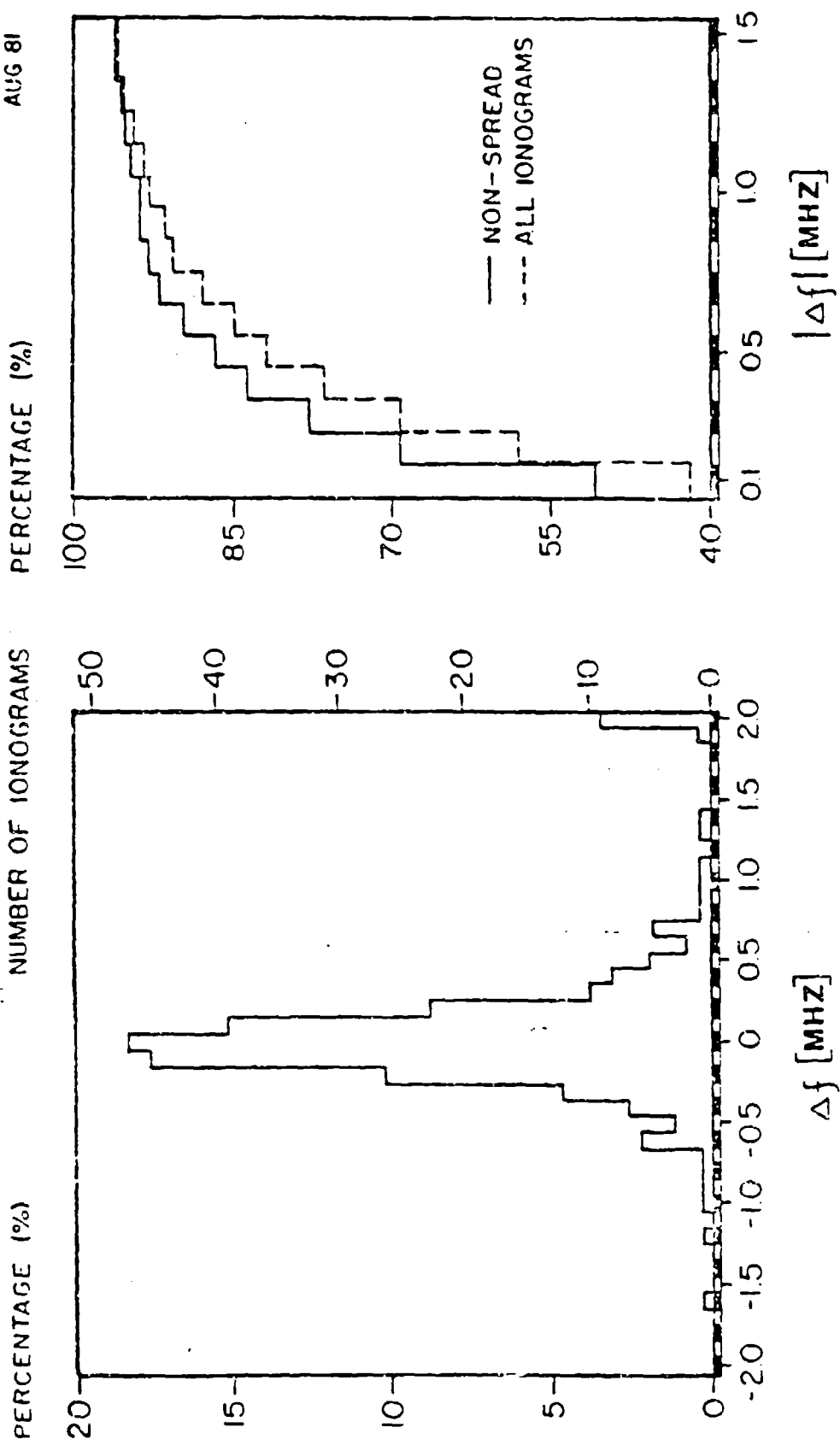
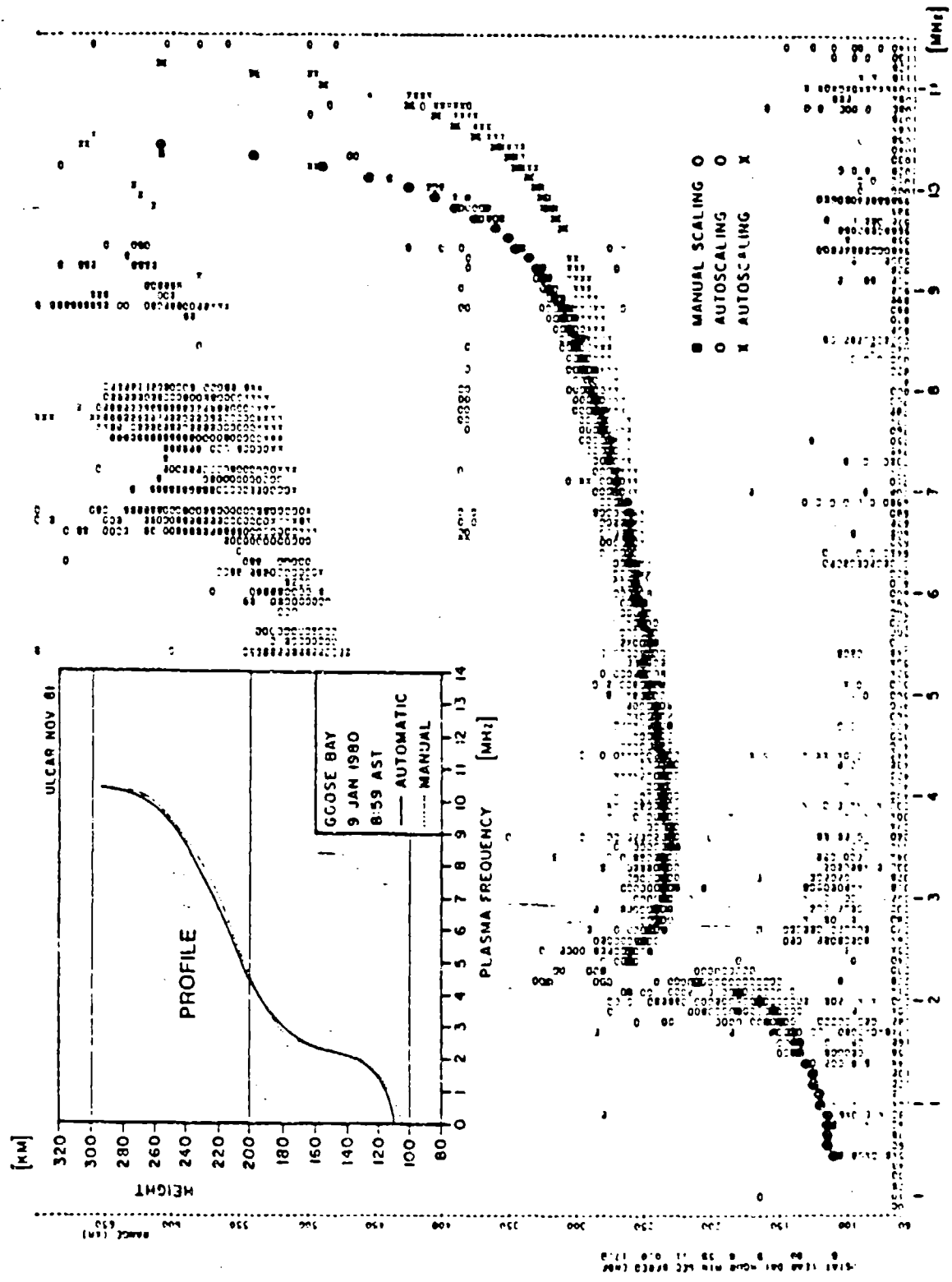

Figure 4.3

ERROR DISTRIBUTION OF FOF2 (MANUAL FOF2-BISA FOF2)

(USING 256 NON-SPREAD IONOGRAMS, JANUARY 1980, GOOSE BAY, LABRADOR)



AUTOMATIC ELECTRON DENSITY PROFILE

GOOSE BAY 9 JAN 1980 8:59 AST

Figure 4.4. AUTOMATICALLY SCALED IONOGRAMS

9-tracks and a latest generation formatter which accepts control words strobed in by a pulse (GO pulse). We recommend the 1600 BPI PE (phase encoded) tape format for reasons of tape economy although the 800 BPI NRZI format is still acceptable. No specific requirement for tape drive speed exists; 37.5, 45 or 75 ips would all be satisfactory.

The tape formatter is programmed by an output port of OUTCO on which specific bits represent Forward, Reverse, Write, Read, EOF, etc. This control word is strobed in by a pulse (GO pulse) which also initiates the start of the desired operation (read a record, write a record, write an end-of-file, etc.). Some operations (rewind, load-on-line) are initiated by a pulse of their own. The actual read (R0-R7) or write (W0-W7) data is transferred directly to or from RAM on the tape DMA (direct memory access) card at a rate determined by the strobe supplied by the formatter. The RAM on the DMA card is disconnected from the computer bus during the actual transfer allowing both the computer and the tape recorder to work independently. All controls such as ONLINE, WRITE, ENABLE, etc. are sequenced automatically by OUTCO. If power to the tape drive is off, end of tape has been reached or some other difficulty has occurred, OUTCO transfers a warning message to the display of the control computer.

4.5 Hardcopy Plotter

Since many years the Digisonde uses a fast electrostatic plotter as an on-line output device: The Versatec Plotter, Model Matrix 1100. Connected to the Digisonde via Connector P the Plotter presents the ionogram data using the optically weighed Optifont^R in regular (4 x 6 dot matrix) or double size (8 x 12 dot matrix) or the 64-level BCD font (8 x 12 matrix). In either case the high valued numbers (large amplitudes) appear with higher intensity thus creating an analog impression of the printout, as demonstrated in Figure 3.9.

The amplitudes of the 128 bins for each frequency are printed in one line. In general the phase information is suppressed for the printout. Greater simplicity is provided by a thermal dot line

THIS
PAGE
IS
MISSING
IN
ORIGINAL
DOCUMENT

84

5.0 SPECIFICATIONS FOR DIGISONDE 256

RF OUTPUT

Frequency Sweep:	Logarithmic and linear 0.5-30 MHz; frequency hopping optional.
Sweep Duration:	20 sec to several minutes depending on frequency sweep, step size, and frequency repetition (Tables 5.1A-D).
Frequency Synthesis:	Digital Synthesis in 5 kHz increments.
Frequency Steps:	Logarithmic sweep : 20, 40 or 80 steps per octave. Linear sweep : 5, 10, 25, 50, 100 or 200 kHz increments (Table 5.2).
Frequency Optimization:	Three frequencies can be tested for minimum interference prior to transmission of each ionogram frequency (Table 5.7b).
Pulse Repetition Rate:	50 Hz, 100 Hz, 200 Hz (Table 5.3b).
Frequency Repetition:	Four to 512 pulses at each frequency (Table 5.3a).
Pulse Width:	66 μ s at 200 Hz; 66 or 133 μ s at 50 and 100 Hz (Table 5.3c).
HF Phase Coding:	Interpulse and intrapulse pseudo-random 180° phase codes (Tables 5.3c and 5.4).
Pulse Peak Power:	10 kW with ULCAR Transmitter.
Output Impedance:	To minimize radiation in building: 50 Ω ; matching transformer at antenna mast: 50:600 Ω ; any mismatch permitted.

RECEIVER

Band Width:	20 kHz, optimum pulse reproduction; fast recovery.
Input Impedance:	50 Ω

Settings		Number of Pulses				Time Per Frequency											
I2	G4	N	T	Pre-run	Integration	Transfer	TT Total	125	250	375	500	625	750	875	1000	[ms]	
0	0	1	048C		4	2	6	50									
0	1	1	048C	3	4	2	9	100	50								
0	0	2	048C		8	2	10	100	50								
0	0	1	159D		2 x 4	4	12	100	50								
0	1	2	048C	3	8	2	13	200	100	50							
0	1	1	159D	3	2 x 4	4	15	200	100	50							
1	X	1	048C	12	4	2	18	200	100	50							
0	0	3	048G		16	2	18	200	100	50							
0	0	2	159D		2 x 8	4	20	200	100	50							
0	1	3	048C	3	16	2	21	200	100	50							
1	X	2	048C	12	8	2	22	200	100	50							
0	1	2	159D	3	2 x 8	4	23	200	100	50							
1	X	1	159D	12	2 x 4	4	24	200	100	50							
0	0	1	26AE		4 x 4	8	24	200	100	50							
0	1	1	26AE	3	4 x 4	8	27	200	100	50							
1	X	3	048C	12	16	2	30	200	100	50							
1	X	2	159D	12	2 x 8	4	32	200	100	50			50				
0	0	4	048C		32	2	34	200	100	50			50				
0	0	3	159D		2 x 16	4	36	200	100	50			50				
1	X	1	26AE	12	4 x 4	8	36	200	100	50			50				
0	0	1	048C	3	32	2	37	200	100	50			50				
0	1	3	159D	3	2 x 16	4	39	200	100	50			50				
0	0	2	26AE		4 x 8	8	40	200	100	50			50				
0	0	1	26AE	3	4 x 8	8	43	200	100	50			50				
1	X	4	048C	12	32	2	46	200	100	50					50		
1	X	3	159D	12	2 x 16	4	48	200	100	50					50		
0	0	1	37BF		8 x 4	16	48	200	100	50					50		

Pulse Repetition Rate [Hz]

8102 2008A
 Bi 25 Mar 81
 Rev. 26 Jul

DGS 256 SOUNDING TIME PER FREQUENCY IN IONOGRAM

Table 1A

Settings		Number of Pulses				Time Per Frequency														
		Pre-run	Integration	Transfer	TT Total	375	500	625	750	875	1000	1125	1250	1375	1500	1625	1750	1875	[ms]	
	G4 N T					3	4	5	6	7	8	9	10	11	12	13	14	15	[1/8 s]	
0	1	37BF	3	8 x 4	16	200		100				50								
1	X	26AE	12	4 x 8	8	200		100				50								
1	X	1 37BF	12	8 x 4	16	200		100				50								
0	0	5 048C		64	2	200			100					50						
0	0	4 159D		2 x 32	4	200			100						50					
1	X	5 048C	3	64	2	200			100						50					
1	X	4 159D	3	2 x 32	4	200			100						50					
0	0	3 26AE	-	4 x 16	8	200			100						50					
0	1	3 26AE	3	4 x 16	8	illegal									50					
1	X	5 048C	12	64	2	200				100						50				
0	0	2 37BF		8 x 8	16	200				100					50					
1	X	4 159D	12	2 x 32	4	200				100					50					
0	1	2 37BF	3	8 x 8	16	200				100							50			
1	X	3 26AE	12	4 x 16	8	200				100							50			
1	X	2 37BF	12	8 x 8	16	200					100								50	

Pulse Repetition Rate [Hz]

8102 2008B
B1 25 Mar 81
Rev. 26 Jul 81

DGS 256 SOUNDING TIME PER FREQUENCY IN IONOGRAM

Table 5.1B

Settings		Number of Pulses						Time Per Frequency											
I2	G4	N	T	Pre-run	Integration	Transfer	TT Total	750	1000	1375	1500	1625	2625	2750	2875	3000	3125	[ms]	
								6	78	11	12	13	21	22	23	24	25	[1/8 s]	Pulse Repetition Rate [Hz]
0	0	6	048C		128	2	130	200		100				50					
0	0	5	159D		2 x 64	4	132	200		100				50					
0	0	6	048C	3	128	2	133	200		100				50					
0	0	5	159D	3	2 x 64	4	135	200		100				50					
0	0	4	26AE	3	4 x 32	8	136	200		100				50					
0	0	4	26AE	3	4 x 32	8	139	200		100				50					
1	1	6	048C	12	128	2	140	200		100				50					
0	0	3	37BF	12	8 x 16	16	144	200		100				50					
1	1	5	159D	12	2 x 64	4	144	200		100				50					
0	0	3	37BF	3	8 x 16	16	147	200		100				50					
1	1	4	26AE	12	4 x 32	8	148	200		100				50					
1	1	3	37BF	12	8 x 16	16	156	200		100				50					
I2	G4	N	T	Pre-run	Integration	Transfer	TT Total	1375	1500	2625	2750	2875	5250	5375	5500	5625	5750	[ms]	
								11	12	21	22	23	42	43	44	45	46	[1/8 s]	Pulse Repetition Rate [Hz]
0	0	7	048C		256	2	258	200		100				50					
0	0	6	159D		2 x 128	4	260	200		100				50					
0	0	7	048C	3	256	2	261	200		100				50					
0	0	6	159D	3	2 x 128	4	263	200		100				50					
0	0	5	26AE	3	4 x 64	8	264	200		100				50					
0	0	5	26AE	3	4 x 64	8	267	200		100				50					
1	1	7	048C	12	256	2	270	200		100				50					
0	0	4	37BF	12	8 x 32	16	272	200		100				50					
1	1	6	159D	12	2 x 128	4	272	200		100				50					
0	0	4	37BF	3	8 x 32	16	275	illegal						50					
1	1	5	26AE	12	4 x 64	8	276	200						50					
1	1	4	37BF	12	8 x 32	16	284	200						50					

8102 2008C
 B1 25 Mar 81
 Rev. 26 Jul 81

DCS 256 SOUNDING TIME PER FREQUENCY IN IONOGRAM

Table 5.1C

267

Settings		Number of Pulses				Time Per Frequency							
I2	G4	N	T	Pre-run	Integration	Transfer	TT Total	2625	2750	5250	5375	5500	[ms]
0	0	8	048C	0	512	2	514	200		100		5500	Pulse Repetition Rate [Hz]
0	0	7	159D	0	2 x 256	4	516	200		100		44	100
0	1	8	048C	3	512	2	517	200		100		43	
0	0	7	159D	3	2 x 256	4	519	200		100			
0	0	6	26AE	0	4 x 128	8	520	200		100			
0	0	6	26AE	3	4 x 128	8	523	200	200	100			
1	1	8	048C	12	512	2	526		200	100			
0	0	5	37BF	0	8 x 64	16	528		200	100			
1	1	7	159D	12	2 x 256	4	528		200	100			
0	1	5	37BF	3	8 x 64	16	531		200	100			
1	1	6	26AE	12	4 x 128	8	532		200	100			
1	1	5	37BF	12	8 x 64	16	540		200	100			
I2	G4	N	T	Pre-run	Integration	Transfer	TT Total	5250	5375	10375	10500	10625	[ms]
0	0	8	159D	0	2 x 512	4	1028	200		100			Pulse Repetition Rate [Hz]
0	1	8	159D	3	2 x 512	4	1031	200		100			
0	0	7	26AE	0	4 x 256	8	1032	200		100			
0	0	7	26AE	3	4 x 256	8	1035	200		100			
0	0	6	37BF	0	8 x 128	16	1040	200		100			
1	1	8	159D	12	2 x 512	4	1040	200		100			
0	0	6	37BF	3	8 x 128	16	1043	200		100			
1	1	7	26AE	12	4 x 256	8	1044	200		100			
1	1	6	37BF	12	8 x 128	16	1052	200	200	100			100

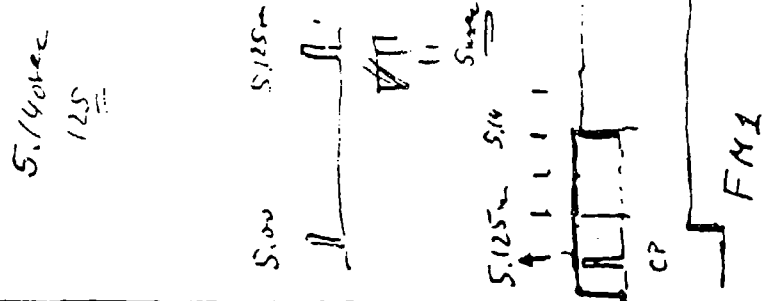

8102 2008D
B1 26 Jul 81

DGS 256 SOUNDING TIME PER FREQUENCY IN IONOGRAM

Table 5.1D

Q	Total Steps	Step Size [kHz]						
		Band Start [MHz]						
	0.5-30.0	0.5	1.0	2.0	4.0	8.0	16.0	
0	150	200 Linear - *						Size [kHz] (Freq. Counter can start at 0.5 MHz for S = 0.0 or 0) offset +12.5 kHz Accur. ± 10 kHz
1	300	100 Linear - *						
2	600	50 Linear - *						
3	1200	25 Linear - * ± 2.5						
4	300	180 + 20 Bi-Linear *						
5	600	90 + 10 Bi-Linear *						
6	1200	40 + 10 Bi-Linear *						
7	2400	20 + 5 Bi-linear *						
8	3000	10 Linear -						offset +2.5 kHz
9	6000	5 Linear -						
A		20 Log ±2.55	40 Log ±2.6	40 Log ±2.7	40 Log ±2.9	40 Log ±3.3	250 ±0	Steps/Oct. Size [kHz] Accur. [kHz]
B		40 Log ±2.55	80 Log ±2.6	80 Log ±2.7	80 Log ±2.9	80 Log ±3.3	125 ±0	Steps/Oct. Size [kHz] Accur. [kHz]
C		80 Log ±2.55	80 Log ±2.6	80 Log ±2.7	80 Log ±2.9	80 Log ±3.3	125 ±0	Steps/Oct. Size [kHz] Accur. [kHz]

Remark: All frequencies have a +2.5 kHz offset in respect to their nominal and indicated value.

FREQUENCY STEPS DGS 256

8011 2800 B1
Rev. 10 Mar 81 Re

Table 5.2

N	Number of Samples		Mode
	W1	W2	
0	No Operation		Ionogram
1		2 x 4†	
2	8†	2 x 8	
3	16	2 x 16	
4	32	2 x 32	
5	64	2 x 64	
6	128	2 x 128	
7	256	2 x 256	
8	512	2 x 512*	

† = only full weight (w3 = 0)

* = only Hanning weight (w3 = 1)

R	Pulse Rate [Hz]	R	Sample Rate [Hz]	Q		
0	50	4	50	No Transmit	8	Horizontal Antenna
2	100	6	100	No Transmit	A	
3	200	7	200	No Transmit	B	

W	Pulse Width [usec]	Sample Weight
0	66	Full
1	133	
2	2 x 66 (intrapulse)	
3	133 (2 samples)	Hanning
4	66	
5	133	
6	2 x 66 (intrapulse)	
7	133 (2 samples)	

DGS 256 NUMBER OF SAMPLES, PULSE RATE AND WIDTH

Table 5.3

8102 2004B
 Bi 14 Mar 81
 Rev. 07 Sep 81

Pulse
Number

++		+	-	+	-	++		++		+	+	-	+	-	-	+		8
++		+	-	+	-	++	or	++		+	+	-	+	-	-	+		16
++		+	-	+	-	++		++		+	-	+	-	+	-	+		32
++	++		-	+	++	-		++	++	-	+	-	++					2 x 4
++	++		-	+	++	-		++	++	-	+	-	++					2 x 8
++	++		-	+	++	-		++	++	-	+	-	++					2 x 16

delete

X =	Code Shift	Window
0	-	All
1	-3	4
2	-2	3
3	-1	2
4	No	1
5	+1	-
6	+2	-
7	+3	-

USEFUL ONE AND TWO CHIP CODES FOR DGS 256

Table 5.4

X	E ₄	Phase Code Shift		Window Number [units of 3000 km for R = 2]
		Transmit	Receive	
0		No Phase Code	No Phase Code	All
1	B	-1	C + -1	2 + 1
2	B	-2	C + -2	3 + 1
3	B	-3	C + -3	4 + 1
4		0	0	1
5		-1	0	2
6		-2	0	3
7		-3	0	4
8	+	0	^{7/8} C, ^{6/9} 0*, -1, -1*	1, 1*, -1, -1*
9	+	-1	0, ^{5/10} 0*, -1, -1*	2, 2*, 1, 1*
10	+	-2	0, ^{4/11} 0*, -1, -1*	3, 3*, 1, 2*
11	+	-3	0, 0*, -1, -1*	4, 4*, 3, 3*
12	+	0*	0, 0*, -1, -1*	1, 1*, -1, -1*
13	+	-1*	0, 0*, -1, -1*	2, 2*, 1, 1*
14	+	-2*	0, 0*, -1, -1*	3, 3*, 2, 2*
15	+	-3*	0, 0*, -1, -1*	4, 4*, 3, 3*

For Remote transmitter code:

B	9	C	D
7/8	6/9	5/10	4/11

 Status at receiver with:

3/12	2/13	1/14	0/15
------	------	------	------

- * = Different Phase Code only for W ≠ 2, 6
- 2 = If X = 1 to 3, E₄ must be 1
- = Communication mode with E₄ = 1 and X₄ = 1

Table 5.4 Phase Code DGS 256-06

8408 0500
Bi 5 Aug 84

not B 1 May 85

Signal/Noise Ratio: 6 dB for 2 μ V input.

Input Protection: Passive diode clipping; if no separate receiving antenna available, tap at dummy end of distributed transmitter power amplifier provides excellent receiver antenna input.

Dynamic Range: 64 dB + 42 dB switchable (automatic and manual), see Table 5.5.

AGC: Digital in 6 dB steps (Table 5.5).

Diurnal Gain Control: Day, Twilight, Night sequence preprogrammed (Table 5.5).

SIGNAL PROCESSING

Sixteen data integration channels shared for doppler, antenna configuration (incidence angle and polarization) and range doubling.

Height Range: Selectable from 10 to 2680 km (see Table 5.6).

Range Bins: 128 or 256 (Table 5.6).

Height Resolution: 2.5, 5.0 or 10.0 km (see Table 5.6).

Spectral Integration: 2, 4, 8 or 16 spectral lines (Table 5.7a).

Wave Polarization: O and X tagging (requires polarized receiving antennas), see Tables 5.8 and 5.9.

Angle of Arrival: One to eight directions (requires seven element receiving array and Antenna Switch), see Tables 5.8 and 5.9.

Dynamic Range: 90 dB.

Amplitude Resolution: ~~3/16 or 3/32 dB~~, *2/8 or 3/8 dB, 3/16 dB optional*

Phase Resolution: 1.4°.

GE -	0	1	2	3	0	1	2	3	0	1	2	3	
G -	Day				Morning/Evening				Night				
0	0				1				2				x
1	1				2				3				x
2	2				3				4				x
3	3				4				5				x
4	4				5				6				x
5	5				6				7				x
6	6				7				7+1				
7	7				7+1				7+1				
8	0	0	1	2	0	1	2	3	1	2	3	4	
9	0	1	2	3	1	2	3	4	2	3	4	5	x
A	1	2	3	4	2	3	4	5	3	4	5	6	x
B	2	3	4	5	3	4	5	6	4	5	6	7	x
C	3	4	5	6	4	5	6	7	5	6	7	7+1	
D	4	5	6	7	5	6	7	7+1	6	7	7+1	7+1	
E	5	6	7	7+1	6	7	7+1	7+1	7	7+1	7+1	7+1	
F	6	7	7+1	7+1	7	7+1	7+1	7+1	7+1	7+1	7+1	7+1	

x = Recommended setting for full gain variance.

RECEIVER ATTENUATION IN 6 [dB] INCREMENTS

Table 5.5

TABLE 5.5 Receiver or transmitter gain
 = 20 dB + 0 dB/day - 1 automatic gain
 + 1 extra noise + 0
 + 2 signal + 1

H [km]	Range Bins	E= 1	2	3	4	5
0	2.5 x 128	10 - 330	60 - 380	160 - 480	380 - 600	760 - 880
1	5 x 128	10 - 650	60 - 700	160 - 800	380 - 520	760 - 1400
2	10 x 128	10 - 1200	60 - 1200	160 - 1600	380 - 1660	760 - 2040
3	2.5 x 40	10 - 110	60 - 160	160 - 260	380 - 480	760 - 860
3	5 x 88	110 - 550	160 - 600	260 - 700	480 - 920	860 - 1300
8	2.5 x 256	10 - 650	60 - 700	160 - 800	380 - 1000	760 - 1400
9	5 x 256	10 - 1200	60 - 1300	160 - 1440	380 - 1660	760 - 2040
A	10 x 256	10 - 2570	60 - 2620	160 - 2720	380 - 3940	
B	2.5 x 128	10 - 330	60 - 380	160 - 480	380 - 720	760 - 1080
B	5 x 128	330 - 970	380 - 1020	480 - 1120	760 - 1240	1080 - 1720
C	5 x 128	10 - 650	60 - 700	160 - 800	380 - 1020	760 - 1400
C	10 x 128	650 - 1930	700 - 1980	800 - 2080	1020 - 2300	1400 - 2680

8102 2003 28 Nov 80
 DGS 256 SAMPLE RANGES Rev. 23 Jul 81

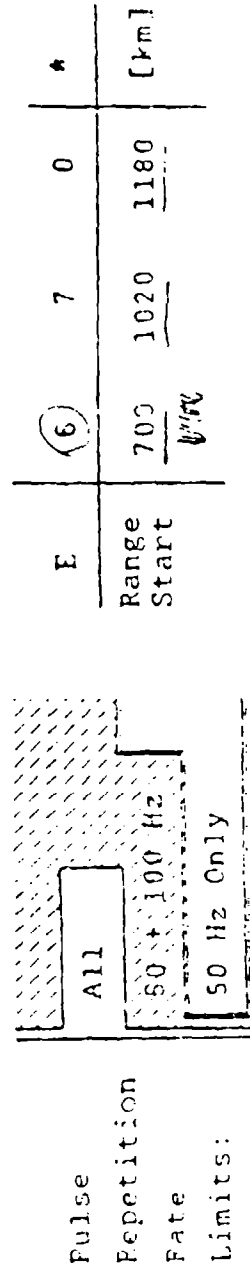

*Option: for E = 9 to D same ranges as for E = 1 to 5, but one-half of Doppler number and additional integration with phase code corresponding to lower range window.

Table 5.c

8/16/81 75

T	Ionogram Antenna Configuration	Spectral Lines: $[\pm 2S]$	
		for $H4 = 0$	for $H4 = 1$
0	1 V	1 3 5 7	1 3 5 7
1	2 V	1 3 5 7	1 3 5 7
2	4 V	1 3	1 3
3	8 V	1	-
		$d_s = (2s-1) \frac{1}{2f}$	
4	1 V	2 6 10 14	2 6 10 14
5	2 V	2 6 10 14	2 6 10 14
6	4 V	2 6	2 6
7	8 V	2	-
		$d_s = 2(2s-1) \frac{1}{2f}$	
8	1 V	1 3 5 7	1 3 5 7
9	2 V	1 3 5 7	1 3 5 7
A	4 V	1 3	1 3
B	8 V	1	-
C	1 V	2 6 10 14	2 6 10 14
D	2 V	2 6 10 14	2 6 10 14
E	4 V	2 6	2 6
F	8 V	2	-

I	Frequency Search [kHz]	Frequency Offset [kHz]	T (Counts)		# Pre-run Pulses
			AGC	AGC	
0	No	0	2	2	2
1	No	10	2	2	2
2	$\pm 10, 0$	10	2	0	2
3	$\pm 20, 0$	20	2	0	2
4	No	0, 10, 15, 25 or 25, 30, 40, 45	2	0	2
5	No	0, 10, 25, 45 or 20, 45, 75, 95	2	0	2
6	No	0, 30, 45, 75 or 50, 55, 65, 75	2	0	2
7	No	0, 15, 30, 45 or 50, 55, 65, 95	2	0	2

AGC: $G \geq 8$

DGS 256 Ionogram Tasks

Table 5.7

8102 2002B
B1 22 Mar 81
Rev. 20 Jul 81

mod B1 29 Apr 85

96 9/11 1/5 A

Doppler Frequencies in Ionogram or Fixed Frequency Modes		
T	Ionogram Antenna Config.	128 Range Bins (H < 6) X = 0, 4, 5, 6, 7
0, 8	1	$\pm 1/2T \pm 3/2T \pm 5/2T \pm 7/2T \pm 9/2T \pm 11/2T \pm 13/2T \pm 15/2T$
1, 9	2	$\pm 1/2T \pm 3/2T \pm 5/2T \pm 7/2T$
2, A	4	$\pm 1/2T \pm 3/2T$
3, B	8	$\pm 1/2T$
4, C	1	$\pm 1/T \pm 3/T \pm 5/T \pm 7/T \pm 9/T \pm 11/T \pm 13/T \pm 15/T$
5, D	2	$\pm 1/T \pm 3/T \pm 5/T \pm 7/T$
6, E	4	$\pm 1/T \pm 3/T$
7, F	8	$\pm 1/T$

Remarks: Doppler Frequencies in (Hz) for Integration Time T in (sec)

I	Frequency Search (kHz)	Frequency Offset (kHz)		J (used in CORE)		No. of Prerun Pulses	
		for F4 and F5 = 0	for F4 or F5 = 1	G < 8	G ≥ 8	G < 8	G ≥ 8
0	No	0	0	2	1	0	3
1	No	10	10	2	1	0	3
2	±10, 0	10	10	0	0	12	12
3	±20, 0	20	20	0	0	12	12
4	No	0, 10, 15, 25	or 25, 30, 40, 45*	6	5	0	3
5	No	0, 10, 25, 45	or 50, 60, 75, 95	6	5	0	3
6	No	0, 5, 15, 35	or 50, 55, 60, 75	6	5	0	3
7	No	0, 15, 30, 45	or 50, 65, 80, 95	6	5	0	3

Remarks: F4 = 25 kHz bit; F5 = 50 kHz bit; *or 50, 60, 65, 75 or 75, 80, 90, 95

8102 2002C
BI 22 Mar 81
Rev. 6 Dec 84

DGS 256 Ionogram Tasks

Table 5.7

~~2/2~~ 9/4

EXTENSION FOR CLOSELY SPACED FREQUENCY MODE

The Closely Spaced Frequency Mode serves to make precise phase and group height measurement either at fixed frequency or in ionogram scanning.

In fixed frequency mode four frequencies can be freely chosen. In ionogram mode at least five frequencies, covering a one Megahertz range, are necessary ($Q = 0$).

Selecting $I = 4, 5, 6$ or 7 (see Table 5.7) four different spacings of the four closely spaced frequencies can be chosen. Originally it was planned to have the samples from four closely spaced frequencies with four Doppler lines each independently integrated. As an alternative 256 range bins with two Doppler lines each can be selected ($H \geq 8$). Both modes require $T = 2, 6, A$ or E , automatically replacing the four antenna configurations by four closely spaced frequencies.

If 128 height ranges and two Doppler lines are sufficient, two antenna configurations still can be sampled with four closely spaced frequencies for $T = 3, 7, B$ or F . The starred (*) modes of Table 5.9 will be applicable. After modification only the ordinarily polarized vertical antenna configuration is allowed for four Dopplers or 256 height ranges: $T = A$ or E and $Z = 7$ or F . For $T = 3$ or 7 and $Z = 7$ ordinary and extraordinary polarization can be sampled independently. For $T = B$ or F there are six possibilities for scanning azimuths $60^\circ, 90^\circ$, or 180° apart either with small or large elevation angles.

On card 08 (Antenna Drive) chip 11 pin 12 has to be cut off and grounded for this extension of the closely spaced frequency modes.

SOUNDING MORE THAN ONE FIXED FREQUENCY

A maximum of four frequencies can be set up in a fixed frequency program. Since there is only one frequency input available in a program, the four drift frequencies in DRIFT Buffer are used instead. The four "DRIFT" frequencies are transmitted sequentially, one frequency per integration period. Frequencies set equal to zero in the DRIFT Buffer are skipped. The Digisonde will cycle through the four frequencies either continuously or for a fixed number of times depending on the "frequency" programmed into the FIXED frequency program. "Frequencies" under 0.5 MHz will activate this four frequencies sounding scheme. For example, a frequency of 0.35 MHz will set the Digisonde to cycle through the four frequencies by 35 times. Hence, the maximum number of cycles is 49 (0.49 MHz). A zero frequency (0.00 MHz) in the FIXED Frequency program indicates continuous sounding sequentially of the four frequencies in the DRIFT Buffer. Frequencies greater than 0.50 MHz in a FIXED frequency program work conventionally, continuously sounding at the respective frequency.

AUTOMATIC SEQUENCING OF TRANSMISSION FOR
OBLIQUE SOUNDING WITH TWO OR MORE STATIONS

The P6 Parameter in the ionosonde operating program is used to set up the Digisonde for intermittent transmission with oblique sounding experiments between two or more ionosondes. With proper selection of P6 the digisonde will transmit only for one integration period (in a scanning program this is one sounding frequency) and then receive only for one, two, three, or four periods. In the ionosonde operating program the 4 bit of R which controls transmission should be kept off so that this P6 parameter can control the 4 bit of R automatically.

- P6=0 normal operation, transmit all of the time.
- P6=1 transmit every other period starting with the 1st.
- P6=2 transmit every other period starting with the 2nd.
- P6=3 transmit once every 3rd period starting with the 1st.
- P6=4 transmit once every 3rd period starting with the 2nd.
- P6=5 transmit once every 3rd period starting with the 3rd.
- P6=6 transmit once every 4th period starting with the 1st.
- P6=7 transmit once every 4th period starting with the 2nd.
- P6=8 transmit once every 4th period starting with the 3rd.
- P6=9 transmit once every 4th period starting with the 4th.
- P6=10 transmit once every 5th period starting with the 1st.
- P6=11 transmit once every 5th period starting with the 2nd.
- P6=12 transmit once every 5th period starting with the 3rd.
- P6=13 transmit once every 5th period starting with the 4th.
- P6=14 transmit once every 5th period starting with the 5th.

2008ES
7 RESING

L1-L4 [L]	Azimuth	Zenith Angle				L5-L8	Drift Antenna	
		Small Name	Pol.	Large Name	Pol.		L5=0	L5=1
0		-	O	-	O		"1"	
1	0° (N)	1	O	N	N	(B)		
2	30°	2	O	O	N-E	(8)		
3	60°	3	O	P	N-E	(8)		
4	90°	4	O	W	W	(A)		
5	120°	5	O	X	N+E	(9)		
6	150°	6	O	Y	N+E	(9)		
7	180°	7	O	S	N	(E)		
8	210°	8	O	T	N-E	(8)		
9	240°	9	O	U	N-E	(8)		
A	270°	A	O	E	E	(A)		
B	300°	B	O	F	N+E	(9)		
C	330°	C	O	G	N+E	(9)		
D		-	O		O		"2"	"5"
E		-	O		O		"3"	"6"
F		-	O		O		"4"	"7"

Polarization O = ordinary circular, except at equator where it should be N. Chart gives start of antenna sequence for input Parameter L_n . Chart can also be used to indicate the output function L_n necessary for the antenna switch to produce Azimuths and Elevations 1 to C and N to G. If bits L7 and L8 are disregarded, ordinary polarization also for low elevations N to G.

DEFINITION OF ANTENNAS AND ANTENNA CONFIGURATION START

DGS 256-08 ANTENNA DRIVE

8107 0601

Bi 5 Jul 81

Table 5.8

Rev 11 May 83

Z =	T =	Azimuth Sequences	T =	Azimuth Sequences	ΔA =
0	0, 4 1, 5 2, 6 3, 7	V 1 N 1 2 L V 1 2 3 4 5 6 L V	8, C 9, D A, E B, F	1 1 2 1 2 3 4 1 2 3 4 5 6 7 8	+1
1	1, 5 2, 6 3, 7	P W 1 3 L V 1 3 5 7 9 B L V	9, D A, E B, F	1 3 1 3 5 7 1 3 1 3 1 3 1 3	+2 *
2	1, 5 2, 6 3, 7	1 V 1 4 L V 1 4 7 A N W L V	9, D A, E B, F	1 4 1 4 7 A 1 4 1 4 1 4 1 4	+3 *
3	1, 5 2, 6 3, 7	O P 1 7 L V 1 7 N S 1 7 L V	9, D A, E B, F	1 7 1 7 N S 1 7 1 7 1 7 1 7	+6 *
4	0, 4 1, 5 2, 6 3, 7	L O V N O L V N O P W X Y L V	8, C 9, D A, E B, F	N N O N O P W N O P W X Y S T	+1
5	1, 5 2, 6 3, 7	L V N P L V <u>N P X S U F L V</u>	8, C 9, D A, E B, F	O N P N P X S N P N P N P N P	+2 *
6	1, 5 2, 6 3, 7	N V N W L V N W S E 1 4 L V	8, C 9, D A, E B, F	P N W N W S E N W N W N W N W	+3 *
7 *	1, 5 2, 6 3, 7	P V N S L V L V L V L V L V	9, D A, E B, F	N S V V V V N S N S N S N S	+6 * *

V = vertical O-polarization; L = vertical X-polarization. Numbers 1 to 9 and letters A to C indicate azimuths for small zenith angles. Letters N, O, P, W, X, Y, S, T, U and E, F, G indicate azimuths for large zenith angles. Details see Table 5.8. This table is valid for $L_n = 1$; for $L_n > 1$, add $(L_n - 1) \times 30^\circ$ to all azimuth values. $Z \geq 8$ is same as $Z - 8$, but different functions on Channel B for oscilloscope display and data scale.

* Modes used for simultaneous closely spaced frequency sampling.

ZENITH, AZIMUTH ANGLE AND POLARIZATION SEQUENCES

FOR IONOGRAM MODE

DGS 256-0E ANTENNA DRIVE

Table 5.9

8107 0600

E1 6 Jul 81

Rev. 3 Dec 84

DIGITAL DATA OUTPUT

Magnetic Tape Recording:

1. Maximum amplitude and its channel number for each range bin.
 - a. One 8-bit character per sample (routine).
 - b. Two 8-bit characters per sample (high resolution).
2. All 16 channels (special experiments) two 8-bit characters per sample.

Tape Usage:

Approximately one 10.5" tape every 8 weeks (1 ionogram/hour, 128 range bins, minimum routine format).

Printout:

Thermal printer with optically weighted font.

- a. 4-bit amplitudes only.
- b. 4-bit status only.
- c. 4-bit amplitudes and 4-bit status 64 characters each.

Remote Ionogram:

RS232C ionogram data output, optional.

ANALOG DATA OUTPUT

Receiver IF:

225 kHz, ≤ 1 VRMS at 50 Ω .

Integrated Data:

DAC maximum integrated amplitude. Synchronization pulses for film recording.

SOUNDER OPERATION

Ionogram Rate:

Selectable from 1 to 120 ionograms per hour (Table 5.10). Days and times of rate changes are selectable. Manual start also.

Ionogram Type:

Ten sets of three ionograms each can be preprogrammed and automatically selected.

GRSOLLETT

O	Ionogram			Total	Spacing	Start Time						
	A	B	C			B	A	B	A	B	C	
0	-	-	-	0	-							
1	60	-	-	60	1			XY'30"				
2	12	-	-	12	5	X1'30"		X6'30"				
3	6	-	-	6	10			X6'30"				
4	5	-	1	6	10			X9'				59'
5	3	-	1	4	15	14'		29'		44'		59'
6	1	-	1	2	30			29'				59'
7	-	-	1	1	60							59'
8	Look-Up Table				Open			Open				
9	60	60	-	120	3			XY'00"	XY'30"			
10	12	12	-	24	2 1/2			X1'30"	X4'00"	X6'30"	X9'30"	
11	6	6	-	12	2 1/2 + 7 1/2				X6'30"	X9'30"		
12	5	6	1	12	5			X4'	X9'			59'
13	3	4	1	8	5 + 10	09'	14'	24'	29'	39'	44'	54' 59'
14	1	2	1	4	5 + 25			24'	29'			54' 59'
15	-	1	1	2	5 + 55							54' 59'

C-Program starts at 59' and replaces A program in the A/B program sequence

DGS 256 IONOGRAM START
 8011 2801
 BI 28 Nov 80
 Rev. 24 Jul 81

Table 5.10

Obanleke

AUTOMATIC OPERATION SCHEDULES

C*

- 0 No automatic operation
- 1 An A program every minute at 30 seconds
- 2 An A program every minute at 30 seconds and a B program every minute at 0 seconds
- 3
 - A
 - B 09, 19, 29, 39, 49 (oblique)
 - C 59 (vertical)
 - F 59, 09, 19, 29, 39, 49
 - G
- 4
 - A 01, 16, 31, 46 (ARTIST)
 - B
 - C
 - F
 - G
- 5
 - A 01 (ARTIST)
 - B
 - C 59 (film)
 - F
 - G
- 14
 - A 03, 13, 23, 33, 43, 53
 - B 0, 1, 2, 3,, 59
 - C
 - F
 - G 0, 1, 2, 3,, 59
- 15
 - A 03, 13, 23, 33, 43, 53
 - B 0, 1, 2, 3,, 59
 - C
 - F 0, 1, 2, 3,, 59
 - G

C = 3, 4, 5, 14, 15 may be modified by using monitor program.

C = 6, 7, 8, 9 are user friendly and may be modified with the AUT 06A, AUT 06B,, AUT 09G commands. Typing carriage return without preceding characters will cycle through all 20 user friendly schedules. Twelve times may be set for each program using M1 = 0, ..., 59 through M12 = 0, ..., 59. Entering an out-of-range number (FF for example) has effect of deleting that entry.

A has priority over B, C. B has priority over C. F has priority over G. An hourly at 58 or 59 minutes has priority over a running A, B, or C program. An F or G set at same time as A, B, or C will commence running after the A, B, or C has finished.

*0 the underline is a reminder that this is the letter 0 not the numeral zero.

Ionogram Scan:	Start and end of frequency scan programmable.
Fixed Frequency:	Between 0.4 and 30 MHz, ⁵ 10 kHz increments.
Drift Mode:	Doppler-Drift measurements in between ionograms on operator request (7 antenna receiving array and Antenna Switch required), see Table 5.11.

SOUNDER CONTROL

On-Site:	<u>Hand-held</u> terminal with 64 character LCD; 9600 baud CRT-terminal (optional).
Remote:	Via full duplex modem/telephone connection.

RECOMMENDED PERIPHERALS

1/2" Tape Drive:	Digi-Data Series 40 with imbedded formatter, or equivalent; 9 tracks, 1600 cpi.
Printer:	HP Thermal Printer Model 9876A.
Antenna Switch:	University of Lowell 14-Input ANTENNA SWITCH with 50 Ω termination.
Ionogram Scaler:	University of Lowell REALTIME-IONOGRAM-SCALER.

L	Antennas	Frequencies	Height Ranges	Max. # Dopplers	Max. # Samples
0	1	1	2	256	256
x 1	4 I	2	1	256	512 x
2	4 I	1	2	256	256
x 3	8 *	2	1	128	256
4	4 O	1	2	256	256
x 5	8 I	2	2	64	128
6	1	1	8	256	256
x 7	4 O	2	1	256	512
x 8	1	2	2	256	256
9	4 I	4	1	128	256
x A	4 I	2	2	128	256
B	8 *	4	1	64	128
x C	4 O	2	2	128	256
x D	8 *	1	2	128	256
x E	1	2	8	128	256
F	4 O	4	1	128	256

N	Antennas	Frequencies	Height Ranges	Samples	Spectral Lines	
					T3 = 0	T3 = 1
5	x	x	x	64	64	32
6	x	x	x	128	128	64
7	x	x	x	256	256	128
8	Only for L = 1 and 7			512	-	256

DGS 256 DRIFT TASKS

8107 0200
 Bi 2 Jul 81
 Rev. 8 Oct 81

Table 5.11

* First data set uses all seven antennas
 directly combined for without delays (for vert cal incidence beam)

L	Antennas	Frequencies	Height Ranges	Max. # Dopplers	Max. # Samples	Channels
0	1	1	2	256	256	2
1	4 I	2	1	256	512	8
2	4 I	1	2	256	256	8
3	8	2	1	128	256	16
4	4 0	1	2	256	256	8
5	8	2	2	64	128	32
6	1	1	8	256	256	8
7	4 0	2	1	256	512	8
8	1	2	2	256	256	4
9	4 I	4	1	128	256	16
A	4 I	2	2	128	256	16
B	8	4	1	64	128	32
C	4 0	2	2	128	256	16
D	8	1	2	128	256	16
E	1	2	8	128	256	16
F	4 0	4	1	128	256	16

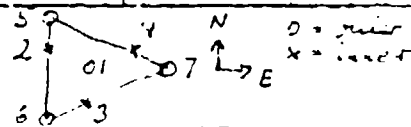

N	Antenna Sequence L		Samples	Spectral Lines		Samples/ Record
	T3 = 0	T3 = 1		T3 = 0	T3 = 1	
5	5, B	-	64	64		1
6	3, 9, A, C, D, E, F	5, B	128	128	64	1
7	1, 2, 4, 6, 7	3, 9, A, C, D, E, F	256	256	128	1
8	-	1, 7	512	-	256	1
5	3, 9, A, C, D, E, F	5, B	64	64	32	2
6	1, 2, 4, 6, 7	3, 9, A, C, D, E, F	128	128	64	2
7	8	1, 2, 4, 6, 7	256	256	128	2
5	1, 2, 4, 6, 7	3, 9, A, C, D, E, F	64	64	32	4
6	8	1, 2, 4, 6, 7	128	128	64	4
7	-	8	256	256	128	4

DGS 256 DRIFT TASKS

81070200

Bi 2 Jul 81

Rev. 4 May 83

Table 5.11

102A

6.0 REFERENCES

"Automatic Processing of Digital Ionograms and Full Wave Solutions for the Profile Inversion Problem," B.W. Reinisch, H.E. Moses and J. [unclear] Final Report, ULRF-417/CAR (1981).

"Automatic Calculation of Electron Density Profiles from Digital Ionograms. Part I. Automatic O and X Trace Identification for Topside Ionograms," B.W. Reinisch and Huang Yeuqin, to be published in Radio Science (1982).

"The RF Radio Environment in the Topside Ionosphere," C. Rush, URSI XXth General Assembly, Session G.4 (1981).

"High Latitude Supplement to the URSI Handbook," W.R. Piggott, World Data Center A for Solar-Terrestrial Physics, Report UAG-50 (1975).

"The Universal Digital Ionosonde," K. Bibl and B.W. Reinisch, Radio Science, 13, pp. 519-530 (1978).

"Font of Digital, or Other, Characters and Method of Pattern Printing Thereof," K. Bibl, U.S. Patent No. 3810095 (1974).

"Direct Digital Graphics," J. Patenaude, K. Bibl and B.W. Reinisch, American Laboratory, pp. 95-101, September 1973.

"Variability of the Equatorial F-Region," K. Bibl, International Reference Ionosphere (IRI) Workshop, COSPAR XXIII Plenary Meeting, Budapest 1980.

UNIVERSITY OF LOWELL
COLLEGE OF PURE AND APPLIED SCIENCE
CENTER FOR ATMOSPHERIC RESEARCH
Lowell, Massachusetts

TAPE FORMAT FOR DGS 256

November 1983

TABLE OF CONTENTS

	Page
1. Tape Description	1
2. Record Types	1
2.1 Scanning Ionogram, MMM'ed Output (Record Types 08H and 09H)	1
2.1.1 Block organization of ionogram data	3
2.2 Dump of Raw Ionogram Data (Record Types 0CH and 0DH)	9

LIST OF TABLES

Table No.		Page
1	Recorded Data: Record Types	2
2	Record Organization of Recorded MMM'ed Ionograms	4
3a	Tape Recorded Preface	5
3b	Tape Recorded Preface	6
4	Block Organization of Recorded MMM'ed Ionograms (Tape Write Control Pl = 1)	7
5	Prelude Organization	8
6	Status # as Function of Dopplers, Heights, Antenna Option and Channel #	10
7	Dump of Raw Data: Record Organization	11
8	Dump of Raw Data (Record Types OCH and ODH): Encoding of Record Type and Preface into 232 Ampli- tude Characters	12

TAPE FORMATS FOR DGS 256

1. Tape Description

All tapes are 9-track 1600 BPI PE format, except for Belgium with 800 BPI NRZI. Odd parity is used. All records on tape have 4096 characters or bytes of 8 bits each. It is possible with some tape recorders that actually 4097 characters will be written due to variations in meaning of the last word command to the tape formatter. When this happens, the last character is meaningless.

2. Record Types

The RECORD TYPE is encoded into the 4 LSB of the first character of each record. Table 1 lists the types of records and summarizes the contents of each; more details are found in the sections below. The Tape Write Control parameter P1 in the ionogram preface directs the Output Computer to write the data on tape (P1 = 0 indicates 'no output to tape'); the record type indicates to the tape reader the type of data in each record.

2.1 Scanning Ionogram, MMM'ed Output (Record Types 08H and 09H)

A routine scanning ionogram consists of 128 or 256 amplitudes and statuses for 128 or 256 range bins at each sounding frequency. In general several records are required for each ionogram; the first record of each ionogram is labelled 09H, and the other records are labelled 08H.

Each record of MMM'ed (Modified Maximum Method) ionogram data contains three initial characters plus 57 4-bit preface characters, followed by a maximum of 30 blocks (30 frequencies) of data with 128 height ranges per block, or a

RECORD TYPE*	DATA TYPE	CONTENT	PI**
08H	Scanning ionogram, MMM'ed output	amplitude + "status"*** 128 ranges, 30 freq/record or 256 ranges, 15 freq/record	1
09H	First record of MMM'ed ionogram		
0AH	Drift	1 case/record	>0
0CH	Dump of raw ionogram data (16 channels/frequency)	amplitude and phase: 1 freq/record	6
0DH	Dump of raw ionogram data (16 channels/frequency)	amplitude only: 2 freq/record	7

*Encoded into the 4 LSB of the first character of each record; for tape reader's information.

**Tape Write Control (programmable by operator; PI = 1 is default).

***Actually, channel number; status must be converted from channel number. See section 2.1.1, and in particular, Table 6.

Table 1. Recorded Data: Record Types

maximum of 15 blocks (15 frequencies) of data with 256 height ranges per block (Table 2). The three initial characters plus preface plus 15 or 30 blocks of data do not add up to a full record of 4096 characters; also, the last frequency of an ionogram may not be the 15th or 30th frequency of the record. After the end of the last block of ionogram data there is an "END" character (0EH), which means that the tape-reading program should ignore the rest of the record.

The three initial characters consist of the RECORD TYPE (08H or 09H), the LENGTH of the preface area (presently 60 characters: 3 initial + 57 preface), and a SPARE character (zero). These three plus the preface are encoded into the 4 LSB's of the first 60 bytes of the record (the 4 MSB's of the first 60 bytes are 0), except that the LENGTH is an 8-bit number.

The preface (Tables 3a and 3b) indicates the time and frequency of transmission, the station number, and other relevant operating and control parameters. The date and time, the frequency of transmission, the begin and end frequencies and the station number are multiple-digit values, with each BCD digit encoded into a separate 4-bit preface character.

2.1.1 Block organization of ionogram data

The 15 or 30 blocks of ionogram data are organized as shown in Table 4. The data for each frequency are preceded by a prelude, which is detailed in Table 5. The block type is determined from the range increment parameter H: with $H < 8$, there are 128 range bins (block type 1); with $H \geq 8$, 256 range bins (block type 2).

Block type 1 uses up to 4080 of the 4096 bytes: $60 + (134 \times 30)$, i.e. 60 preface + ((6 prelude + 128 data) \times 30 frequencies). Character 4081 or the character following the last block of data is the END character (0EH). The bit

RECORD CHARACTER		CONTENT OF EACH RECORD
1	4 LSB	Record Type (08H; 09H if first record of ionogram)
2	8 bits	Length of preface area including the 3 initial characters (3CH: 3 + 57)
3		Spare (always zero)
4-60	4 LSB	57 4-bit Preface Characters
61-4080	8 bits	30 blocks of data (128 ranges/block)
4081*		End of information on record (0EH)
4082-4096		Not Used

Table 2a. 128 Height Bins: Block Type 1
(see Table 4a, also)

RECORD CHARACTER		CONTENT OF EACH RECORD
1	4 LSB	Record Type (08H; 09H if first record of ionogram)
2	8 bits	Length of preface area including the 3 initial characters (3CH: 3 + 57)
3		Spare (always zero)
4-60	4 LSB	57 4-bit Preface Characters
61-3990	8 bits	15 blocks of data (256 ranges/block)
3991*		End of information on record (0EH)
3992-4096		Not Used

Table 2b. 256 Height Bins: Block Type 2
(see Table 4b, also)

*Or after the last block of data if the ionogram ends before block 30 (128 height bins) or before block 15 (256 height bins).

Table 2. Record Organization of Recorded MMM'ed Ionograms

PREFACE CHARACTER	SYMBOL	FUNCTION
Date and Time		
1 - 2	Y = YY	Year
3 - 5	D = DDD	Day
6 - 7	H = HH	Hour
8 - 9	M = MM	Minute
10 - 11	S = SS	Second
General Control Parameters		
12	S	Program Set
13	P	Program Type
14 - 19	J	Journal (internal controls)
Nominal Frequency		
20 - 25	F = FFFFFFF	Frequency (100 Hz)
Output Controls		
26	P1	Tape Write Control
27	P2	Printer Control
28	P3	Maximum Method Options
29	P4	Printer Cleaning Threshold
30	P5	Printer Gain Level
31	P6	For Future Use
32	P7	For Future Use
Frequency Choice		
33 - 34	S = SS	Start Frequency (MHz)
35	Q	Frequency Increment
36 - 37	U = UU	End Frequency (MHz)
Test Output		
38	C	Trigger
39	A	Channel A: Digital
40	B	Channel B: D/A

Table 3a. Tape Recorded Preface

PREFACE CHARACTER	SYMBOL	FUNCTION
Station Identification		
41 - 43	V	Station No. from INCPU Personality
Operating Parameters		
44	X	Phase Code
45	L	Antenna Azimuth
46	Z	Antenna Scan
47	T	Antenna Option and Doppler Spacing
48	N	Number of Samples
49	R	Repetition Rate
50	W	Pulse Width and Code
51	K	Time Control
52	I*	Frequency Correction (from CORE)
53	G*	Gain Correction (from CORE)
54	H	Range Increments
55	E	Range Start
56	J	Frequency Search
57	G	Nominal Gain
Drift Parameters		
58 - 60	H1 = HHH	Height 1 (km)
61	G1 = G	Gain 1 (-6 dB)
62 - 65	F1 = FFFF	Frequency 1 (10 kHz)
66 - 68	H2 = HHH	Height 2
69	G2 = G	Gain 2
70 - 73	F2 = FFFF	Frequency 2
74 - 76	H3 = HHH	Height 3
77	G3 = G	Gain 3
78 - 81	F3 = FFFF	Frequency 3
82 - 84	H4 = HHH	Height 4
85	G4 = G	Gain 4
86 - 89	F4 = FFFF	Frequency 4

Table 3b. Tape Recorded Preface

BLOCK	CHARACTER	CONTENT (1 FREQ/BLOCK)	PRELUDE ORGANIZATION: see Table 5
1	61-66	Prelude	BIT STRUCTURE (DATA): AMPL (4 MSB) + STATUS (4 LSB)*
	67-194	128 Data	
2	195-200	Prelude	RANGES/BLOCK: 128 (H < 8)**
	201-328	128 Data	
.	.	.	BLOCK SIZE: 134 (6 + 128) bytes
.	.	.	
30	3947-3952	Prelude	MAXIMUM BLOCKS/RECORD: 30
	3953-4080	128 Data	
	4081	0EH End of information on record	
	4082-4096	Not Used	

Table 4a. Block Type 1

BLOCK	CHARACTER	CONTENT (1 FREQ/BLOCK)	PRELUDE ORGANIZATION: see Table 5
1	61-66	Prelude	BIT STRUCTURE (DATA): AMPL (5 MSB) + STATUS (3 LSB)*
	67-322	256 Data	
2	323-328	Prelude	RANGES/BLOCK: 256 (H ≥ 8)**
	329-584	256 Data	
.	.	.	BLOCK SIZE: 262 (6 + 256) bytes
.	.	.	
15	3729-3734	Prelude	MAXIMUM BLOCKS/RECORD: 15
	3735-3990	256 Data	
	3991	0EH End of information on record	
	3992-4096	Not Used	

Table 4b. Block Type 2

*Actually channel number; the 4-bit channel no. (see text about converting the 3-bit channel no. to 4 bits) must be converted to status using Table 6.

**H = Range Increment Parameter

Table 4. Block Organization of Recorded MMM'ed Ionograms
(Tape Write Control P1 = 1)

CHARACTER		CONTENTS OF PRELUDE
1		Block type (1, 2, ...)*
2	4 MSB 4 LSB	10 MHz BCD digit 1 MHz BCD digit
3	4 MSB 4 LSB	100 kHz BCD digit 10 kHz BCD digit
4	4 MSB 4 LSB	Frequency search parameter "I" Gain parameter "G"
5	4 MSB 4 LSB	10's of seconds BCD digit Units of seconds BCD digit
6		Most probable amplitude for this frequency (0 - 31 range)

*Only block types 1 and 2 are presently implemented.

Table 5. Prelude Organization

structure of each byte of data is AAAASSSS: a 4-bit AMPLITUDE encoded into the 4 MSB, with a 4-bit STATUS (actually, the channel number from which the amplitude was selected) encoded into the 4 LSB. The status is obtained from the channel number, using Table 6.

Block type 2 uses up to 3990 of the 4096 bytes: $60 + (262 \times 15)$, i.e. 60 preface + ((6 prelude + 256 data) \times 15 frequencies). Character 3991 or the character following the last block of data is the END character. The bit structure of each byte is AAAAASSS: a 5-bit amplitude encoded into the 5 MSB, and a 3-bit STATUS in the 3 LSB. SSS, which is actually the 3 MSB of the channel number, must be converted back to a 4-bit channel number before being used to determine the status from Table 6: for the first 128 range bins of each frequency, $\text{chan. \#} = 2 \times \text{SSS}$; for range bins 129 to 256, $\text{chan. \#} = 2 \times \text{SSS} + 1$.

2.2 Dump of Raw Ionogram Data (Record Types OCH and ODH)

Each record of type OCH contains the amplitudes and phases of all 16 channels of data ($16 \times (128 \text{ amplitudes} + 128 \text{ phases})$; see Table 7a) outputted from CORE for one ionogram sounding frequency. Each record of type ODH contains the amplitudes only of all channels of data for two sounding frequencies ($16 \times 128 \text{ amplitudes} + 16 \times 128 \text{ amplitudes}$; Table 7b). All amplitudes and all phases are 8-bit binary numbers; however, as explained below, the lowest bit(s) of some amplitudes are undefined because they have been replaced by preface information.

For both dump types, the preface area consists of a 4-bit record type and 57 4-bit preface characters. These 58 characters are encoded serially into the lowest bit of each of the first 232 (4×58) amplitude characters of each record, as illustrated in Table 8. (Note that in the OCH dump, the first

# OF DOPPLERS	2		4		8		16
	128	256	128	256	128	256	
# OF HEIGHTS*							128
ANT OPTION (T)	3,7,11,15	2,6,10,14	2,6,10,14	1,5,9,13	1,5,9,13	0,4,8,12	0,4,8,12
CHANNEL	STATUS		STATUS		STATUS		STATUS
0	8		8		8		8
1	9		9		9		9
2	10		10		10		10
3	11		11		11		11
4	12		12		12		12
5	13		13		13		13
6	14		14		14		14
7	15		15		15		15
8	0		4		6		7
9	1		5		7		6
10	2		6		4		5
11	3		7		5		4
12	4		0		2		3
13	5		1		3		2
14	6		2		0		1
15	7		3		1		0

*H < 8: 128 heights; H ≥ 8: 256 heights

Table 6. Status # as Function of Dopplers, Heights, Antenna Option and Channel #

RECORD	CHANNEL	CONTENTS		
CHARACTER		AMPLITUDE/PHASE		PREFACE (Table 8)
1	1	A1	4 MSB	Rec Type (parallel)
2-4		A2-A4	7 MSB	Rec Type (serial)
5-128		A5-A128	7 MSB	Preface 1-31
129-256		φ1-φ128	8-bit	
257-360	2	A1-A104	7 MSB	Preface 32-57
361-384		A105-A128	8-bit	
385-512		φ1-φ128	8-bit	
.	.	.	.	
3841-3968	16	A1-A128	8-bit	
3969-4096		φ1-φ128	8-bit	

Table 7a. Record Type OCH: Amplitudes and Phases
(1 Frequency/Record)

RECORD	FREQ	CHAN	CONTENTS		
CHARACTER			AMPLITUDE		PREFACE (Table 8)
1	1	1	A1	4 MSB	Rec type (parallel)
2-4			A2-A4	7 MSB	Rec type (serial)
5-128			A5-A128	7 MSB	Preface 1-31
129-232		2	A1-A104	7 MSB	Preface 32-57
233-256			A105-A128	8-bit	
.	.	.	.		
1921-2048	2	16	A1-A128	8-bit	
2049-2176		1	A1-A128	7 MSB	Unused, Pref 1-31
2177-2280		2	A1-A104	7 MSB	Preface 32-57
2281-2304			A105-A128	8-bit	
.		.	.	.	
3969-4096		16	A1-A128	8-bit	

Table 7b. Record Type ODH: Amplitudes Only
(2 Frequencies/Record)

Table 7. Dump of Raw Data: Record Organization

232 amplitudes are in two groups separated by a group of 128 phases, i.e. in record characters 1 to 128 and 257 to 360 -- Table 7a; in the ODH dump, the first 232 amplitudes are in record characters 1 to 232 -- Table 7b.) The lowest-order bit of each of amplitudes 1 to 4 is replaced by one of the 4 bits of the record type, with the LSB of the record type encoded into amplitude 1; similarly, each preface character is encoded into a group of four amplitude characters, with the LSB of the preface character encoded into the first amplitude of the group. In addition, the record type without being serialized is encoded into the 4 LSB of the first character of each record, with both the serial and parallel representations of the record type sharing the same LSB. In ODH dumps, the preface for the second frequency is encoded serially into amplitudes 5 to 232 of frequency 2 (amplitudes 5 to 128 of channel 1 and 1 to 104 of channel 2: record characters 2053 to 2280).

The meaning of each preface character is given in Tables 3a and 3b; see also the last paragraph in Section 2.1. The Drift parameters (preface characters 58 - 89) are only defined in the OAH record types.