

2

# NAVAL POSTGRADUATE SCHOOL Monterey, California

AD-A277 354



94-09411



**DTIC**  
**SELECTE**  
**MAR 28 1994**  
**S B D**

## THESIS

**OPTIMAL ADAPTIVE ESTIMATION ALGORITHM  
FOR HARMONIC CURRENT REDUCTION USING POWER  
LIMITED ACTIVE LINE CONDITIONERS**

by

Joel E. Zupfer

December, 1993

Thesis Advisor:  
Co-Advisor

Robert W. Ashton  
Roberto Cristi

Approved for public release; distribution is unlimited.

**94 3 25 103**

DTIC QUALITY INSPECTED 1

REPORT DOCUMENTATION PAGE			Form Approved OMB No. 0704-0188	
Public reporting burden for this collection of information is estimated to average 1 hour per response, including the time for reviewing instruction, searching existing data sources, gathering and maintaining the data needed, and completing and reviewing the collection of information. Send comments regarding this burden estimate or any other aspect of this collection of information, including suggestions for reducing this burden, to Washington Headquarters Services, Directorate for Information Operations and Reports, 1215 Jefferson Davis Highway, Suite 1204, Arlington, VA 22202-4302, and to the Office of Management and Budget, Paperwork Reduction Project (0704-0188) Washington DC 20503.				
1. AGENCY USE ONLY (Leave blank)	2. REPORT DATE 16 December 1993.	3. REPORT TYPE AND DATES COVERED Master's Thesis		
4. TITLE AND SUBTITLE OPTIMAL ADAPTIVE ESTIMATION ALGORITHM FOR HARMONIC CURRENT REDUCTION USING POWER LIMITED ACTIVE LINE CONDITIONERS.			5. FUNDING NUMBERS	
6. AUTHOR(S) Joel E. Zupfer				
7. PERFORMING ORGANIZATION NAME(S) AND ADDRESS(ES) Naval Postgraduate School Monterey CA 93943-5000			8. PERFORMING ORGANIZATION REPORT NUMBER	
9. SPONSORING/MONITORING AGENCY NAME(S) AND ADDRESS(ES)			10. SPONSORING/MONITORING AGENCY REPORT NUMBER	
11. SUPPLEMENTARY NOTES The views expressed in this thesis are those of the author and do not reflect the official policy or position of the Department of Defense or the U.S. Government.				
12a. DISTRIBUTION/AVAILABILITY STATEMENT Approved for public release; distribution is unlimited.			12b. DISTRIBUTION CODE A	
13. ABSTRACT (maximum 200 words) The ability to measure and compensate for power line harmonics has become a growing area of interest because of today's commonly used electronic equipment. Since the number and relative magnitudes of the harmonics on the power line are a function of the load, estimation of an equivalent load can be accomplished. Because of variation in the load, the need for an adaptive algorithm is imperative. Thus far, few algorithms for determining harmonic contents have not dealt with the problem associated with the limited power of the line conditioner. This thesis deals with a previously known harmonic compensating algorithm and introduces a new algorithm which both compensates for harmonic noise and estimates the load as a transformation matrix depending on the associated transfer function of the active line conditioner in use.				
14. SUBJECT TERMS Line Conditioners, Least Square Estimation, Power Line Harmonics, Adaptive Estimation.			15. NUMBER OF PAGES 51	
			16. PRICE CODE	
17. SECURITY CLASSIFICATION OF REPORT Unclassified	18. SECURITY CLASSIFICATION OF THIS PAGE Unclassified	19. SECURITY CLASSIFICATION OF ABSTRACT Unclassified	20. LIMITATION OF ABSTRACT UL	

NSN 7540-01-280-5500 Standard Form 298 (Rev. 2-89)  
Prescribed by ANSI Std. Z39-18

Approved for public release; distribution is unlimited.

Optimal Adaptive Estimation Algorithm for Harmonic Current Reduction  
using Power Limited Active Line Conditioners

by

Joel E. Zupfer  
Lieutenant, United States Navy  
B.S., Grove City College

Submitted in partial fulfillment  
of the requirements for the degree of

MASTER OF SCIENCE IN ELECTRICAL ENGINEERING

from the

NAVAL POSTGRADUATE SCHOOL

December 1993

Author:

  
Joel E. Zupfer

Approved by:



Robert W. Ashton, Thesis Advisor

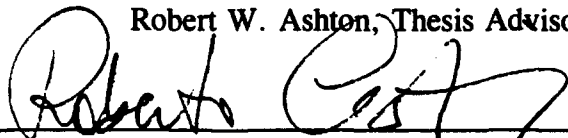

Roberto Cristi, Co-Advisor

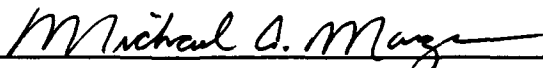

Michael A. Morgan, Chairman

Department of Electrical and Computer Engineering

## ABSTRACT

The ability to measure and compensate for power line harmonics has become a growing area of interest because of today's commonly used electronic equipment. Since the number and relative magnitudes of the harmonics on the power line are a function of the load, estimation of an equivalent load can be accomplished. Because of variation in the load, the need for an adaptive algorithm is imperative. Thus far, few algorithms for determining harmonic contents have not dealt with the problem associated with the limited power of the line conditioner.

This thesis deals with a previously known harmonic compensating algorithm and introduces a new algorithm which both compensates for harmonic noise and estimates the load as a transformation matrix depending on the associated transfer function of the active line conditioner in use.

<b>Accession For</b>	
NTIS GRA&I	<input checked="" type="checkbox"/>
DTIC TAB	<input type="checkbox"/>
Unannounced	<input type="checkbox"/>
Justification	
By	
Distribution	
Availability Codes	
Dist	Avail and/or Special
A-1	

## TABLE OF CONTENTS

I. INTRODUCTION .....	1
A. BACKGROUND .....	1
B. ACTIVE LINE CONDITIONERS .....	4
1. Equivalent Circuit Modeling .....	4
II. SURVEY OF PREVIOUS WORK .....	7
A. ADAPTIVE ESTIMATION OF HARMONIC VOLTAGE .....	7
B. LINEAR LOAD SIMULATION .....	10
C. NONLINEAR LOAD SIMULATION .....	15
III. OPTIMAL ESTIMATION WITH SYSTEM IDENTIFICATION .....	19
A. MODELING THE NETWORK .....	19
B. CONTROL .....	21
C. ESTIMATION .....	23
1. Considerations in Applying FFT to Harmonic Analysis .....	24
D. SIMULATION RESULTS .....	25
IV. CONCLUSIONS .....	30

A. MSE ALGORITHM VS. OPTIMAL ESTIMATOR . . . . .	30
B. FUTURE RESEARCH . . . . .	30
APPENDIX A - (MATLAB) ADAPTIVE LINEAR MODEL . . . . .	31
APPENDIX B - (MATLAB) ADAPTIVE NONLINEAR MODEL . . . . .	34
APPENDIX C - (MATLAB) OPTIMAL ESTIMATION MODEL . . . . .	37
LIST OF REFERENCES . . . . .	41
INITIAL DISTRIBUTION LIST . . . . .	42

## LIST OF FIGURES

Figure 1.1 Bus with Linear and Nonlinear Loads and Active Line Conditioner . . .	1
Figure 1.2 Bus Voltage, Line Conditioner Template and Current . . . . .	5
Figure 1.3 System Approximation using Norton Equivalent Circuit . . . . .	5
Figure 2.1 Block Diagram of Adaptive System . . . . .	8
Figure 2.2 Single Weight Error Surface Example . . . . .	10
Figure 2.3 Linear Load Equivalent Circuit Model . . . . .	11
Figure 2.4 Mean Square Error for Linear Load . . . . .	12
Figure 2.5 Total Harmonic Distortion Linear Load . . . . .	13
Figure 2.6 Sine & Cosine Weighting Coefficients for Linear Load . . . . .	14
Figure 2.7 Nonlinear Load Equivalent Circuit Model . . . . .	15
Figure 2.8 Mean Square Error Nonlinear Load . . . . .	16
Figure 2.9 Total Harmonic Distortion Nonlinear Load . . . . .	17
Figure 2.10 Sine & Cosine Weighting Coefficients for Nonlinear Load . . . . .	18
Figure 3.1 Optimal Estimation Impedance Model . . . . .	19
Figure 3.2 Discrete Time Period . . . . .	21
Figure 3.3 System Diagram with Estimation and Control . . . . .	25
Figure 3.4 Control Input to Conditioner $U_k$ . . . . .	27
Figure 3.5 Total Harmonic Distortion (THD) . . . . .	28

**LIST OF TABLES**

TABLE 2.1 TOTAL HARMONIC DISTORTION FOR LINEAR AND NONLINEAR LOADS .....	15
TABLE 3.1 ACTUAL AND ESTIMATED IMPEDANCE MATRIX COEFFICIENTS .....	29

## ACKNOWLEDGEMENT

I would like thank my advisor, Professor Ashton, for allowing me to work on this project and for all his patience during the writing and debugging of the programs in this thesis. Also to Professor Cristi for his inventive thinking and help in the formulation of the "System Identification" topics.

Also I would like to thank my wife, Anne, and daughter, Grace, whose support and love enabled me to complete this work.

## I. INTRODUCTION

### A. BACKGROUND

Many of today's electronic devices *i.e.*, computers, fluorescent lights and microwave ovens, effect power distribution due to their nonlinear consumption of power. The result is irregular current and voltage wave forms on the power line. Active line conditioners provide a way of eliminating the accompanying noise on a power line by independently adjusting the active and nonactive components, thereby maintaining a constant sinusoidal bus voltage.

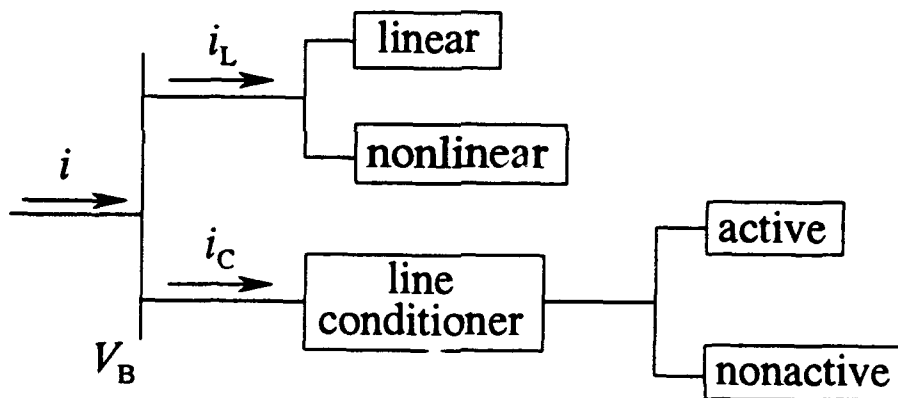

Figure 1.1 Bus with Linear and Nonlinear Loads and Active Line Conditioner

The amount of voltage distortion is a function of the nonlinear load distribution, their current spectra, topology and frequency dependance within the network. For a nonsinusoidal voltage [Ref 1]

$$V_B = \sqrt{2} V_1 \sin \omega t + \sqrt{2} \sum_{h=1} V_h \sin(h\omega t + \alpha_h) \quad (1.1)$$

with linear and non linear loads drawing a total current.

$$i_L = i_{a1} + i_{r1} + i_H \quad (1.2)$$

where

$$i_{a1} = \sqrt{2}I_1 \cos\theta_1 \sin\omega t \quad (1.3)$$

is the active component of the fundamental current,

$$i_{r1} = \sqrt{2}I_1 \sin\theta_1 \cos\omega t \quad (1.4)$$

is the reactive component of the fundamental current and

$$i_H = \sqrt{2} \sum_{h=1} I_h \sin(h\omega t + \alpha_h + \theta_h) \quad (1.5)$$

is the harmonic current. The apparent power can be described as follows.

$$S = V_{rms} I_{rms} = \sqrt{(V_1^2 + \sum_{h=1} V_h^2)(I_1^2 + \sum_{h=1} I_h^2)} \quad (1.6)$$

Equation 1.6 can be expressed in phasor form,

$$S = \sqrt{(P_1 + P_H)^2 + Q_1^2 + Q_H^2} \quad (1.7)$$

where

$$P_1 = V_1 I_1 \cos\theta_1 \quad (1.8)$$

represents the Fundamental Power Frequency Active Power. The Harmonic Active Power is,

$$P_H = \sum_{h=1} V_h I_h \cos\theta_h \quad (1.9)$$

and

$$Q_1 = V_1 I_1 \sin\theta_1 \quad (1.10)$$

is the Power Frequency Reactive Power. The Harmonic Reactive Power is

$$Q_H = \sum_{h=1} V_h I_h \sin\theta_h \quad (1.11)$$

The components of  $Q_H$  are generated by specific harmonic voltages and harmonic currents (in no particular order) [Ref 2]. Because of the vector properties of the reactive power components, control or cancellation is possible using vectors of identical frequency and magnitude with opposite phase. Therefore, the Harmonic Reactive Power can be eliminated by introducing or drawing current from the power line which is  $180^\circ$  out of phase with each respective harmonic. With this in mind, the conditioner current is as follows,

$$i_C = i_{cal} + i_{crl} + i_{CH} \quad (1.12)$$

where  $i_{cal}$  and  $i_{crl}$  are the conditioner Fundamental Active and Reactive currents respectively, and

$$i_{CH} = \sqrt{2} \sum_{h=1} I_{Ch} \sin(h\omega t + \alpha_h + \gamma_h) \quad (1.13)$$

is the conditioner harmonic current.

## B. ACTIVE LINE CONDITIONERS

Active line conditioners serve a dual purpose. First, they adjust one or more loads thereby changing the active power. Secondly, they are capable of controlling the amplitude and phase characteristics of the nonreactive currents  $i_{Cl}$  and  $i_{CH}$  which affect the value of  $Q_l$  and/or  $Q_H$  [Ref 2,4]. By using a solid state switching network at a frequency much greater than that of the fundamental, the line current is modulated in order to maintain the boundaries of a desired template  $z$ , shown in Figure 1.2. For a narrow boundary of error  $\delta$ , the conditioner current  $i_c$  is unaffected by the fluctuations (the zig-zaging) within the boundary area. By adjusting the template waveform through a feedback circuit, the conditioner current spectrum can be altered to produce an overall current  $i_T$  that is as close to sinusoidal as possible. To do this, the load current  $i_L$  is monitored to determine the harmonics present. Then by injecting a current  $i_c$  from the line conditioner which is  $180^\circ$  out of phase with that of the load, the unwanted harmonics can be cancelled out.

### 1. Equivalent Circuit Modeling

For medium and low voltage systems, the best practical means of adjusting the conditioner current  $i_c$  is by minimization of the voltage distortions at the conditioner location on the bus [Ref. 5]. The voltage at the conditioner node can be represented by

$$\mathbf{V}_{Bh} = \sum_{x=1}^N \mathbf{Z}_{Bxh} \mathbf{I}_{xh} \quad (1.14)$$

where

$\mathbf{I}_{xh}$  = Bus  $x$  harmonic current phasor of order  $h$

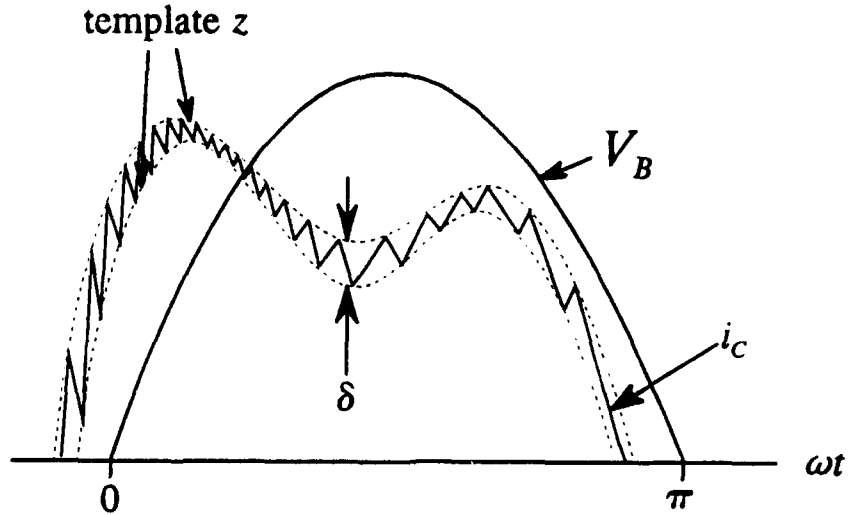

Figure 1.2 Bus Voltage, Line Conditioner Template and Current

$Z_{Bxh}$  = Harmonic Complex Impedances of the node  
 $N$  = Number of independent nodes

A Norton equivalent circuit for the bus has the equivalent harmonic current

$$I_{eh} = Y_{BBh} \sum_{x=1}^N Z_{Bxh} I_{xh} \quad (1.15)$$

where  $Y_{BBh} = 1/Z_{BBh}$  is the self-admittance of the node for the harmonic  $h$ . Figure 1.3 shows the Norton equivalent circuit with the associated harmonic currents and load  $Z_{Sh}$ .

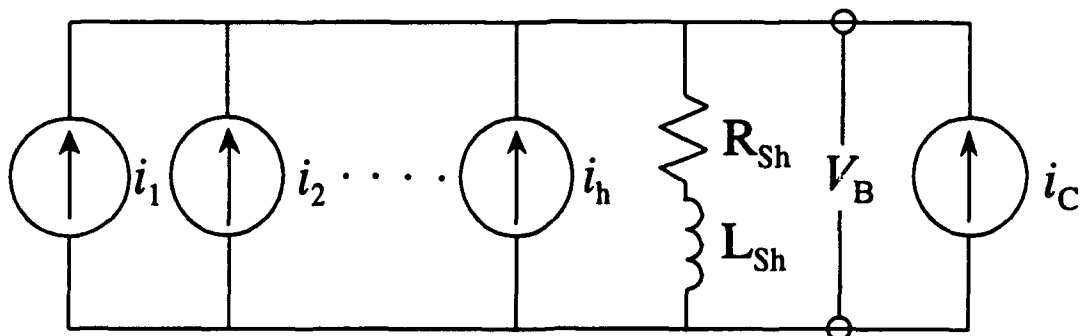

Figure 1.3 System Approximation using Norton Equivalent Circuit

Where  $Z_{Sh}$  is given in Equation 1.16,

$$Z_{Sh} = R_{Sh} + jh\omega L_{Sh} = Z_{BBh} \| Z_{Bh} \quad (1.16)$$

and  $Z_{Bh}$  is the load impedance of the harmonic order  $h$ .

From the equivalent load  $Z_{Sh}$  the voltage due to the offending harmonics  $V_{Hh}$  can be defined as

$$V_{Hh} = I_{eh} Z_{Sh} \quad (1.17)$$

For a linear resistance and inductor  $R_{Sh}$  and  $L_{Sh}$ , a conditioner current  $i_C$  equal to the negative of  $I_{eh}$  would eliminate the harmonic voltage  $V_{Hh}$ . It is important to note that active line conditioners are inherently limited in their maximum current output, therefore, negating the entire value of  $I_{eh}$  may not be possible. Although limited, any reduction of the harmonic noise, especially of lower order, significantly improves the recognition of the fundamental.

## II. SURVEY OF PERVIOUS WORK

### A. ADAPTIVE ESTIMATION OF HARMONIC VOLTAGE

The best fitting sinusoidal wave to a nonsinusoidal periodic wave is the fundamental [Ref. 1]. The error associated with such a system can be written.

$$e = v_B - v_1 = v_H + v_C \quad (2.1)$$

Since the signals  $v_H$  and  $v_1$  are periodic, the error,  $e$ , is statistically stationary. Therefore, the expected value of the square of the error  $e$  results in a quadratic function which has a guaranteed minimum for real physical signals [Ref. 6]. Then by minimizing the mean square of the error (MSE), the signal should be nearly identical to that of the fundamental. By representing the error voltage due to the harmonics as the sum of weighted sines and cosines, an error surface for each weight can be defined thereby making the calculation of a minimum possible. Figure 2.1 shows the block diagram for such an adaptive system.

$x_{S2}, x_{S3} \dots x_{Sh}$  and  $x_{C2}, x_{C3} \dots x_{Ch}$  represent discrete versions of the harmonics associated with the power line, and  $C_2, C_3, \dots C_h$  and  $S_2, S_3, \dots S_h$  are the weights of the associated harmonic. The correction voltage to the conditioner is defined by

$$y_k = \sum_{h=1} [S_h \sin(h\omega kT/N) + C_h \cos(h\omega kT/N)] \quad (2.2)$$

where  $k =$  time index  
 $T = 1/f = 2\pi/\omega =$  period or one cycle

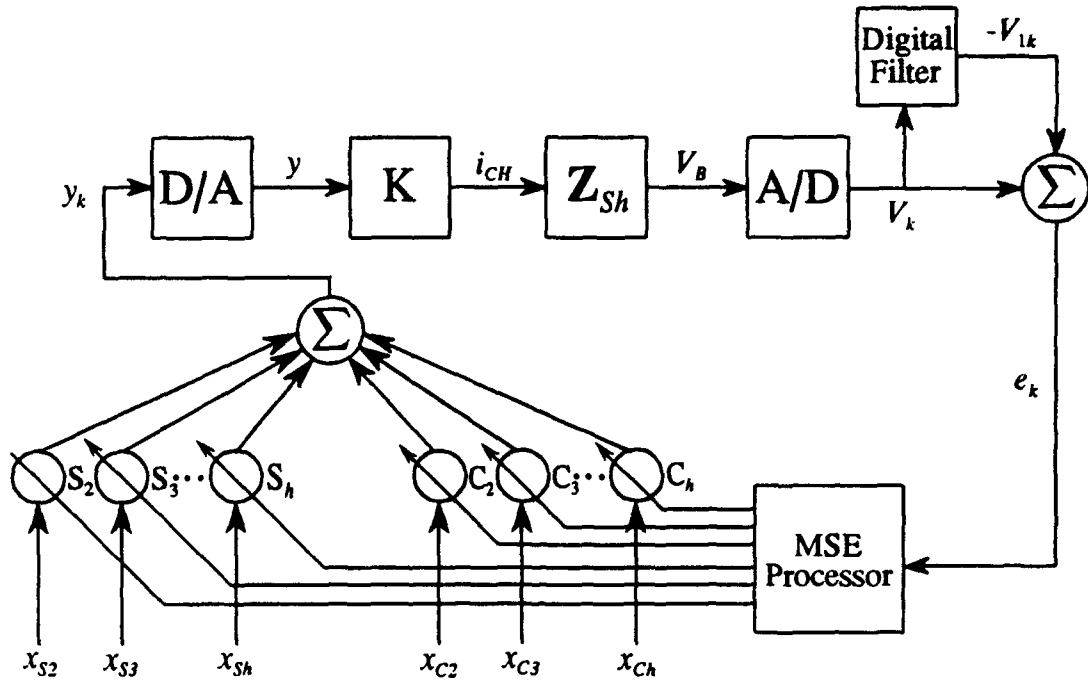

Figure 2.1 Block Diagram of Adaptive System

$N$  = number of samples per cycle

The Active Line Conditioner current is given by

$$i_{CH} = KD \sum_{h=1} [S_h \sin(h\omega t) + C_h \cos(h\omega t)] \quad (2.3)$$

where  $D$  = The gain of the D/A converter  
 $K$  = Converter constant of the Conditioner in (A/V)

The discrete error  $e_k$  as a function of voltage becomes

$$e_k = v_{Ck} + v_{Hk} \quad (2.4)$$

where  $v_{Ck}$  and  $v_{Hk}$  are represented by

$$v_{Ck} = KD \sum_{h=1} Z_{Sh} [S_h \sin(h\omega kT/N) + C_h \cos(h\omega kT/N)] \quad (2.5)$$

$$v_{Hk} = \sqrt{2} \sum_{h=1} Z_h I_{eh} [\cos\beta_h \sin(h\omega kT/N) + \sin\beta_h \cos(h\omega kT/N)] \quad (2.6)$$

Simply setting the sine and cosine weights equal to

$$\begin{aligned} S_h &= -\sqrt{2}(I_{eh} \cos\beta_h)/KD \\ C_h &= -\sqrt{2}(I_{eh} \sin\beta_h)/KD \end{aligned} \quad (2.7)$$

requires the error to be zero. Since the actual load impedance  $Z_{Sh}$  is not known and changes with time, an estimation of the sine and cosine weights is performed by the MSE processor using the following linear prediction.

$$\begin{aligned} S_{k+1} &= S_k + (-\nabla_S) \mu/h \\ C_{k+1} &= C_k + (-\nabla_C) \mu/h \end{aligned} \quad (2.8)$$

where

$$\begin{aligned} \nabla_S &= \partial e / \partial S \\ \nabla_C &= \partial e / \partial C \end{aligned} \quad (2.9)$$

are the error gradients of the sine and cosine weights respectively, and  $\mu$  is a constant called the acceleration factor which is directly related to both the rate of convergence, and the magnitude of any over-shoot in reaching the minimum. The  $h$  term is used to scale the acceleration factor by an amount proportional to the harmonic being evaluated. This allows for faster convergence of lower order harmonics, the largest error, without driving the higher order unstable. Figure 2.2 shows a quadratic error surface as a function of a single weight.

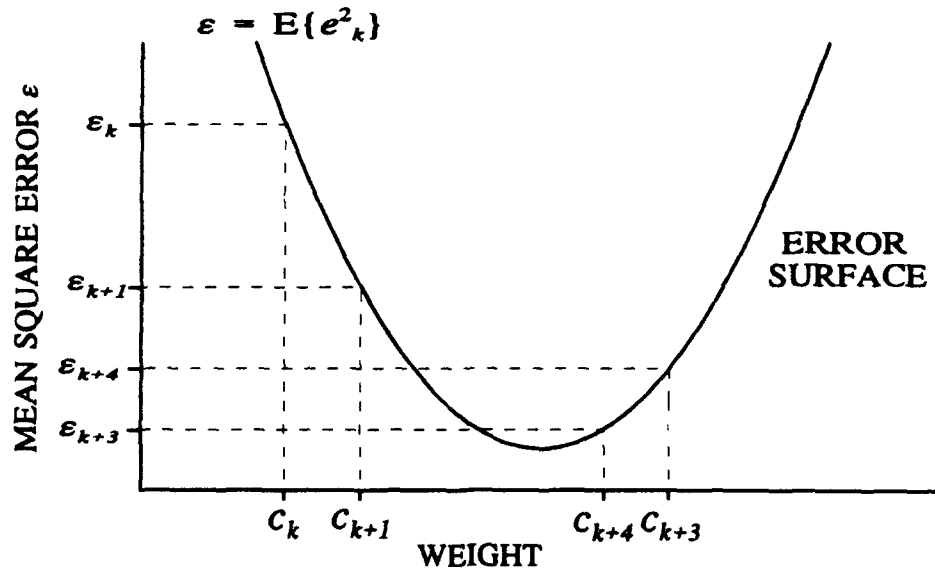

Figure 2.2 Single Weight Error Surface Example

Starting on the left side where  $C_{k+1} > C_k$  and  $\varepsilon_{k+1} < \varepsilon_k$  the gradient is negative and the value of  $\varepsilon$  converges toward the minimum. If the value of the weighting factor produces a higher error than the previous  $\varepsilon_{k+4} > \varepsilon_{k+3}$ , an overshoot occurs, but the gradient remains negative thereby predicting a smaller weighting value than the current one and  $\varepsilon$  again converges toward the minimum. The same result would be obtained for an initial weight greater than that needed to minimize  $\varepsilon$ .

## B. LINEAR LOAD SIMULATION

A program for testing the validity of the adaptive algorithm was written for MATLAB using the parameters in Figure 2.3 and a noise component equating to ten percent Total Harmonic Distortion (THD) assuming only odd harmonics up to the twenty-first [Ref. 1]. The fundamental frequency is assumed to be a standard 60 Hz outlet and the line conditioner to have no power limitation.

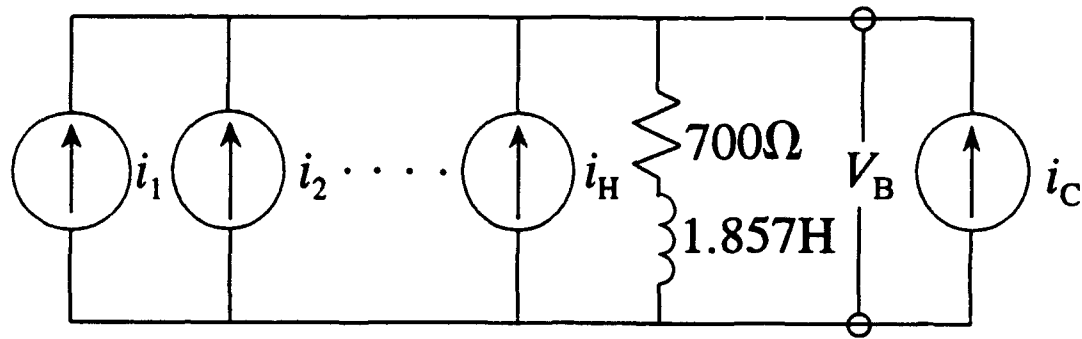

Figure 2.3 Linear Load Equivalent Circuit Model

Figure 2.4 shows the MSE for the first three offending harmonics and their convergence to zero, all well under one second using an acceleration constant of  $3e-7$ . The THD in Figure 2.5 also follows a similar pattern since it is most affected by the lower order harmonics and becomes one-one hundredth of its original value after just one half second, or thirty iterations. Figure 2.6 shows the weighting coefficients of the sine and cosine for the first three offending harmonics. With the help of a simple trigonometric identity, these values can easily be shown to correspond to the magnitude and phase of the original noise components. Also note that the final weighting values were reached asymptotically without any over-shoot indicating the choice of the acceleration coefficient is optimal with respect to requiring minimum power from the active line conditioner.

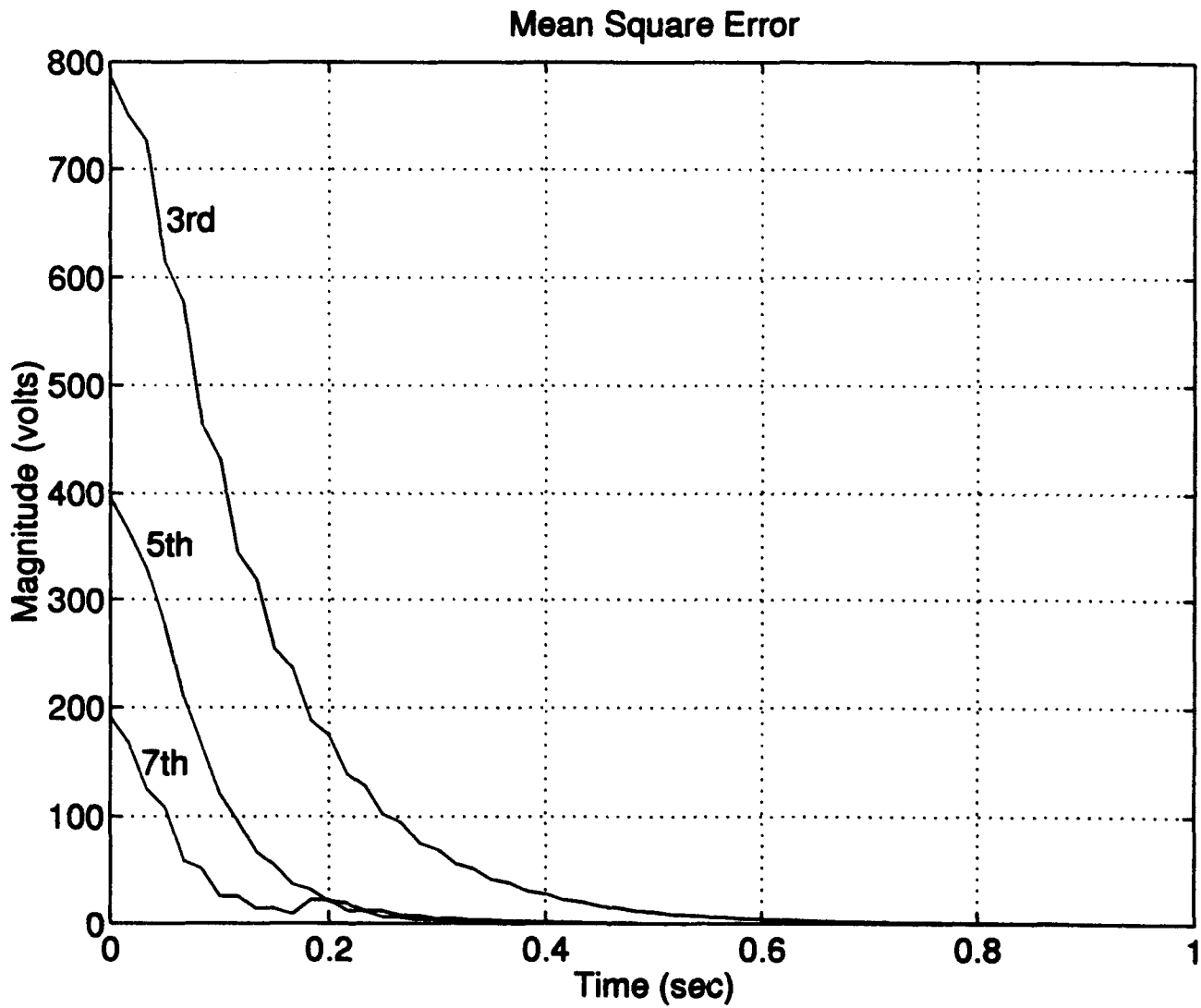

Figure 2.4 Mean Square Error for Linear Load

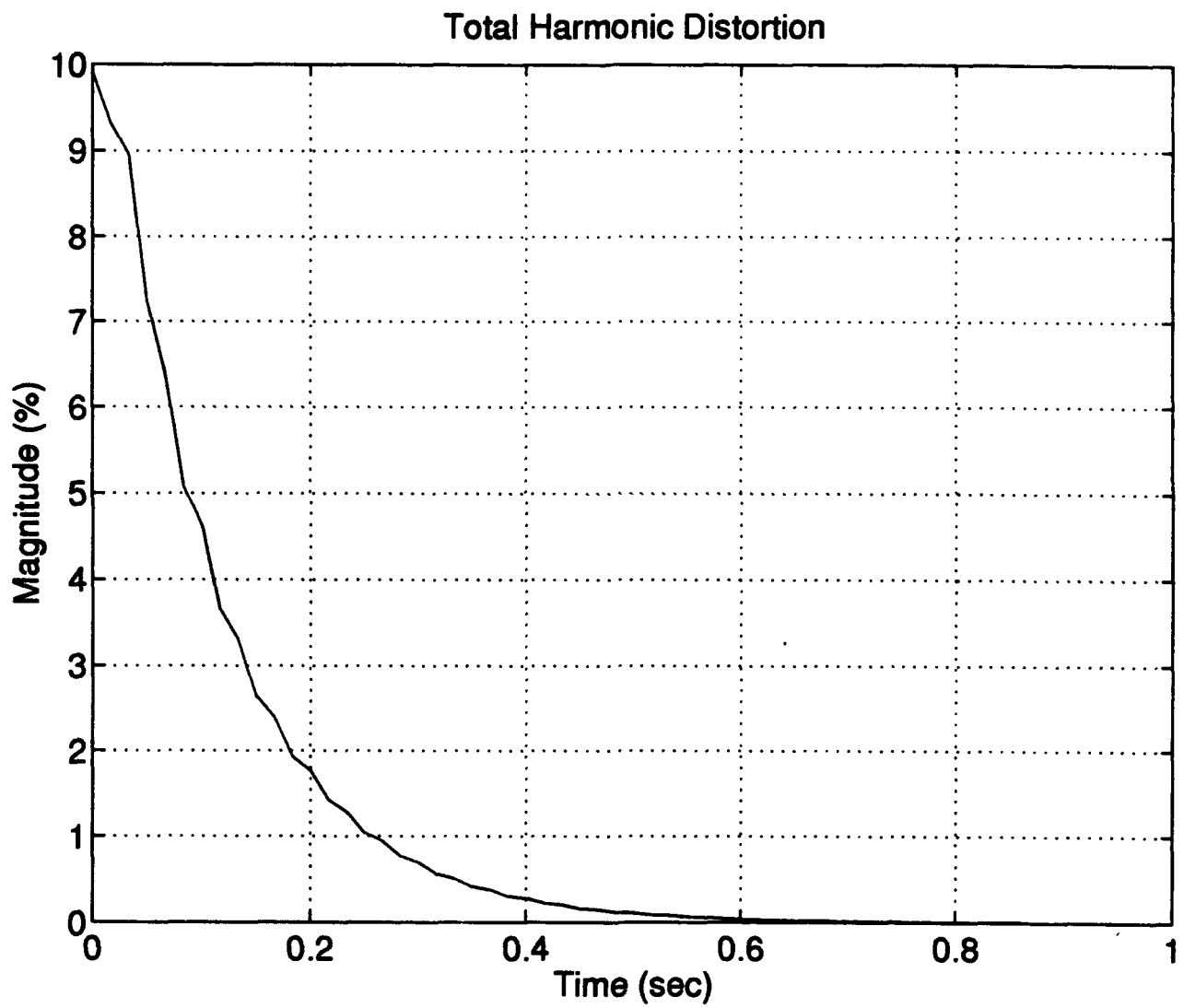

Figure 2.5 Total Harmonic Distortion Linear Load

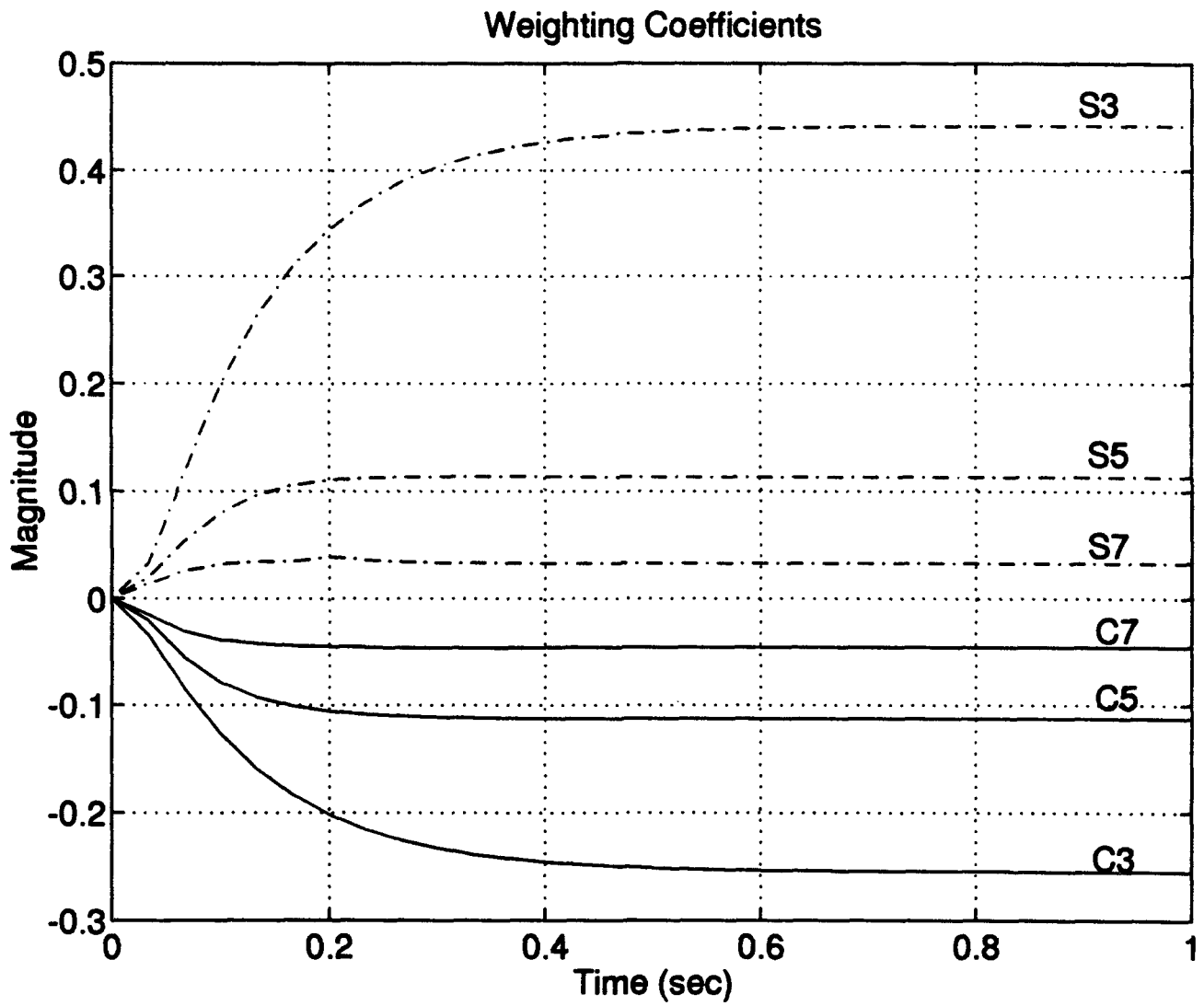

Figure 2.6 Sine & Cosine Weighting Coefficients for Linear Load

### C. NONLINEAR LOAD SIMULATION

The inductor in Figure 2.3 was substituted for the one shown in Figure 2.7 to produce a nonlinear response in the load. The nonlinearity was chosen to provide approximately ten percent deviation from that of the linear case.

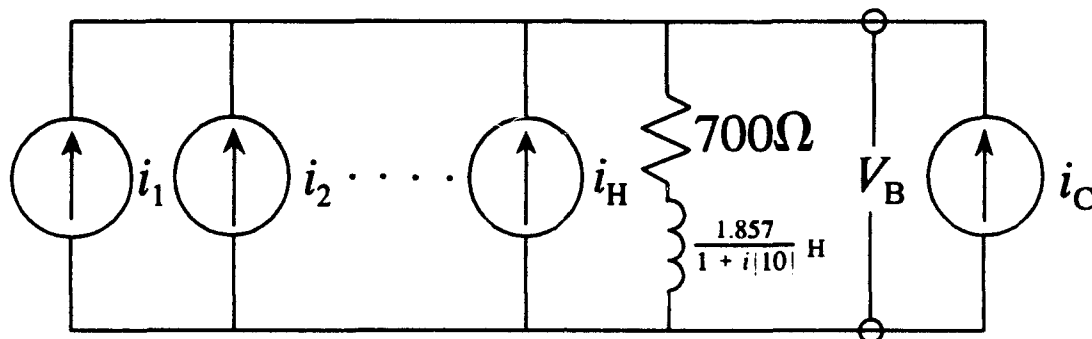

Figure 2.7 Nonlinear Load Equivalent Circuit Model

The nonlinear load results were very similar to those from the linear with small deviations in the THD and identical results for the weighting coefficients. Some of these values are summarized below in Table 2.1.

TABLE 2.1 TOTAL HARMONIC DISTORTION FOR LINEAR AND NONLINEAR LOADS

Time (sec)	.0167	.0333	.0667	.133	.250	.500	1.00
Linear	9.327	8.849	6.381	3.300	1.047	.123	.0011
Nonlinear	9.245	8.874	6.410	3.427	1.120	.120	.0012

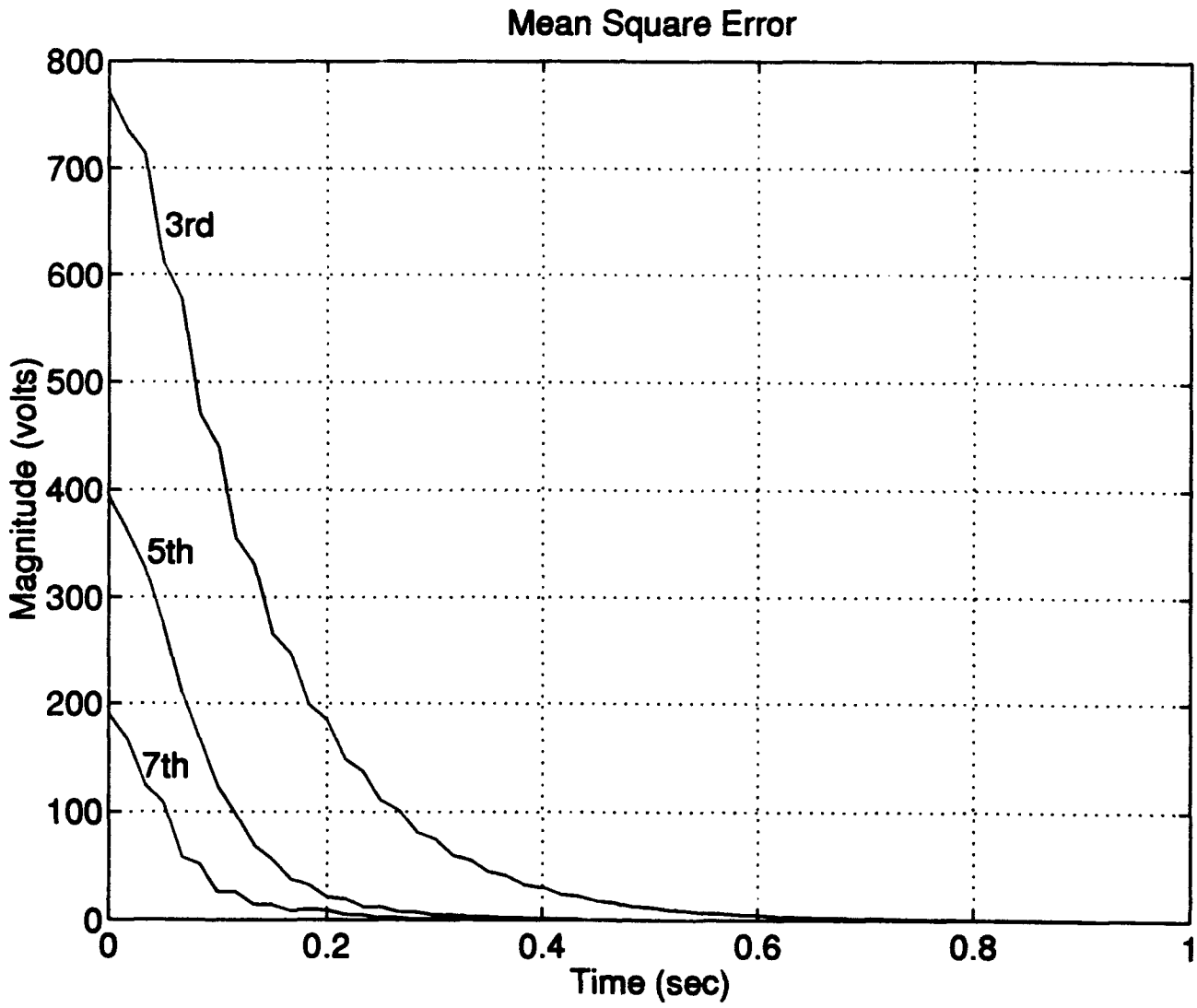

Figure 2.8 Mean Square Error Nonlinear Load

### Total Harmonic Distortion

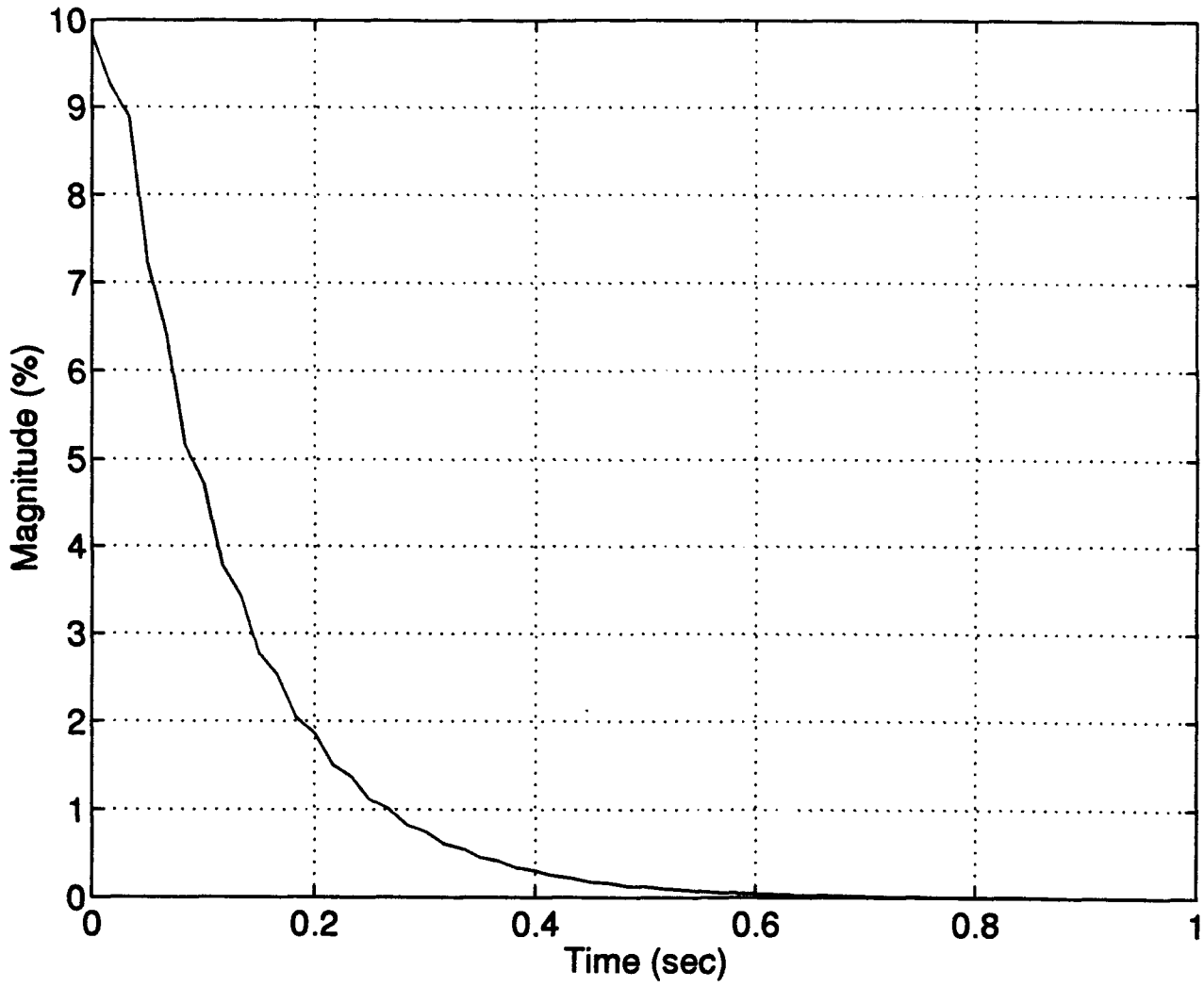

Figure 2.9 Total Harmonic Distortion Nonlinear Load

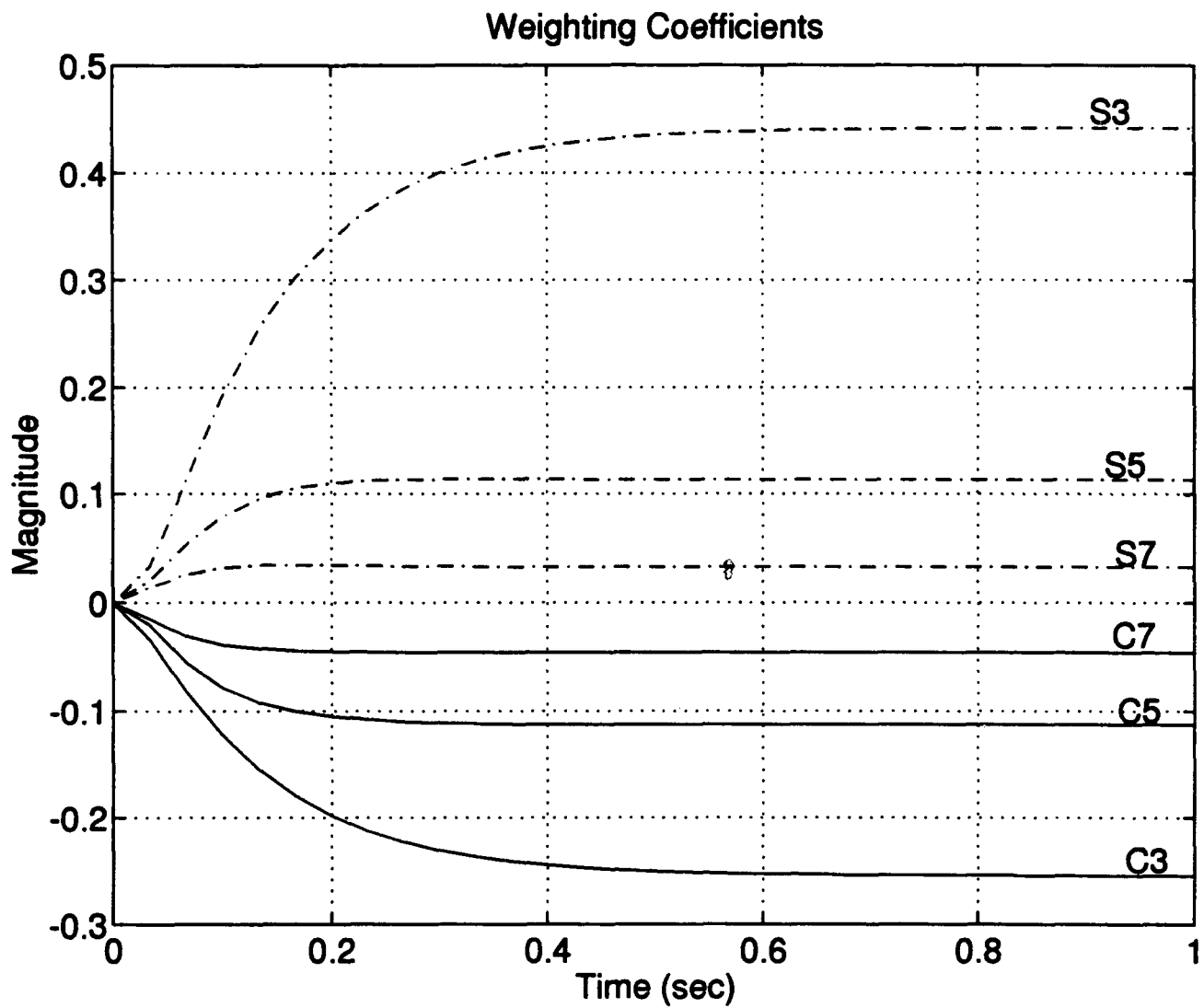

Figure 2.10 Sine & Cosine Weighting Coefficients for Nonlinear Load

### III. OPTIMAL ESTIMATION WITH SYSTEM IDENTIFICATION

#### A. MODELING THE NETWORK

The model used for optimal estimation is very similar to that found in Figure 2.1 with the exception that the impedance, although unknown, will be estimated along with minimizing the harmonic error. The block diagram model is shown in Figure 3.1 with the impedance of the present load represented as a square matrix  $\mathbf{H}$ . It should be noted that this model can be used for different system transfer function input/output relationships other than current to voltage.

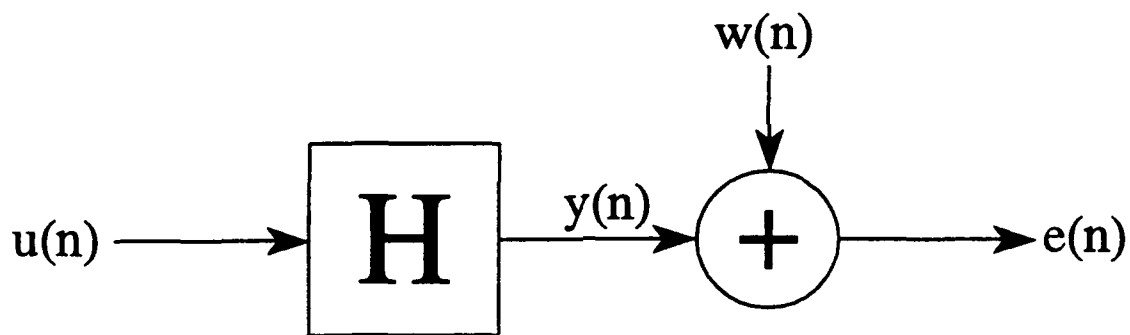

Figure 3.1 Optimal Estimation Impedance Model

Since the harmonic noise  $w(t)$  is assumed to be harmonics of the fundamental it can be represented as a sum of sinusoids shown in Equation 3.1 for a continuous signal.

$$w(t) = \sum_{x=2}^{N_h} A_x \cos(2\pi x f_0 t) + B_x \sin(2\pi x f_0 t) \quad (3.1)$$

For a discrete sampled system Nyquist criteria must be maintained, therefore the sampling frequency,  $f_s$ , must be an integer value of the fundamental which is greater than twice the highest harmonic frequency to be eliminated. The continuous frequencies are converted to discrete under the following conditions.

$$2\pi l \frac{f_0}{f_s} = 2\pi \frac{l}{M} \quad \text{where } 1 \leq l \leq N_h < \frac{M}{2} \quad (3.2)$$

From this the disturbance  $w(t)$  can be represented discretely in matrix form as

$$w(n) = W^T x(n) \quad (3.3)$$

where

$$\begin{aligned} W^T &= [0, 0, A_2, B_2, A_3, B_3, \dots, A_{N_h}, B_{N_h}] \\ x(n) &= [\cos 2\pi \frac{1}{M} n, \sin 2\pi \frac{1}{M} n, \cos 2\pi \frac{2}{M} n, \sin 2\pi \frac{2}{M} n, \dots, \\ &\quad \cos 2\pi \frac{N_h}{M} n, \sin 2\pi \frac{N_h}{M} n]^T \end{aligned} \quad (3.4)$$

Because the harmonic noise does not change instantaneously with changes to the load, it is reasonable to assume that it is periodic. By dividing the time scale into periodic intervals of length  $N$ , which is a multiple of  $M$ , then for all  $n$   $x(n) = x(n + M) = x(n + N)$ .

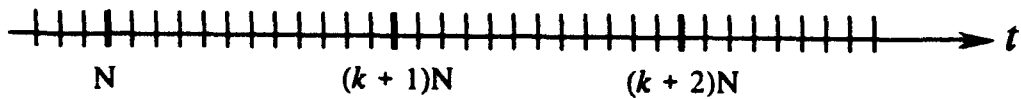

Figure 3.2 Discrete Time Period

By defining the control input current to be

$$u(n) = \mathbf{u}_k^T \mathbf{x}(n) \quad kN \leq n \leq kN + N - 1 \quad (3.5)$$

where  $\mathbf{u}_k$  is a weight vector to be determined. The error can now be written discretely in terms of  $\mathbf{x}(n)$  as

$$e(n) = \mathbf{W}^T \mathbf{x}(n) + \mathbf{u}_k^T \mathbf{H}^T \mathbf{x}(n) \quad (3.6)$$

Note that for a linear impedance  $\mathbf{H}$  becomes a diagonal matrix, otherwise it is not.

Since  $w(n)$  is the signal which is to be eliminated, by using its frequency information in the control input,  $u(n)$ , it will provide some of the needed information to negate it. The remaining control information will come from a recursive estimation of its Fourier coefficients which is the main basis of this algorithm.

## B. CONTROL

Since the value of  $\mathbf{H}$  can be estimated through the use of system identification techniques, it can be assumed to be known for the purpose of determining the control necessary to eliminate the harmonic noise. From Equation 3.6 it is easy to see that  $\mathbf{W}^T$  and  $\mathbf{u}_k^T \mathbf{H}^T$  are scalars which can be combined to represent the error weights for each

sample point over a single interval,  $N$ , of the fundamental. The error associated with a single sample  $n$  is shown in Equation 3.7.

$$\mathbf{e}(n) = \mathbf{e}_k^T \mathbf{x}(n) \quad (3.7)$$

Now each term in Equation 3.6 can be defined in terms of  $\mathbf{x}(n)$ .

Due to the periodicity of the harmonic frequencies, the frequency components can be eliminated by subtracting the error of the  $k^{\text{th}}$  interval from the  $(k-1)^{\text{th}}$  interval resulting in a difference equation of just weighted vectors shown below.

$$\begin{aligned} \mathbf{e}_k^T \mathbf{x}(n) &= \mathbf{W}^T \mathbf{x}(n) + \mathbf{u}_k^T \mathbf{H}^T \mathbf{x}(n) \\ \mathbf{e}_{k-1}^T \mathbf{x}(n-N) &= \mathbf{W}^T \mathbf{x}(n-N) + \mathbf{u}_{k-1}^T \mathbf{H}^T \mathbf{x}(n-N) \\ \mathbf{e}_k^T - \mathbf{e}_{k-1}^T &= \mathbf{H}^T (\mathbf{u}_k^T - \mathbf{u}_{k-1}^T) \end{aligned} \quad (3.8)$$

After some manipulation, Equation 3.8 can be written as

$$\mathbf{Q}(\mathbf{e}_k - \mathbf{e}_{k-1}) = \mathbf{u}_k - \mathbf{u}_{k-1} \quad (3.9)$$

where  $\mathbf{Q} = \mathbf{H}^{-1}$

Now that the control is in terms of the error and an admittance matrix  $\mathbf{Q}$ , using a linear predictor similar to that in Equation 2.8 can be used.

$$\mathbf{u}_k = \mathbf{u}_{k-1} - \alpha \mathbf{Q} \mathbf{e}_{k-1} \quad (3.10)$$

where  $\alpha$  is a scalar defined on the interval  $-1 < \alpha < 1$ .

The error,  $\mathbf{e}_k$ , can be driven to zero for  $\mathbf{Q}$  not equal to the null set.

### C. ESTIMATION

Because the load to the bus changes over time some method of updating the value of  $\mathbf{H}$  to those changes must exist in order for the controller to effectively reduce the harmonic noise present. Estimation of the admittance matrix  $\mathbf{Q}$  can easily be incorporated with the control through system identification methods using a recursive least squares (RLS) algorithm. By choosing estimates of the control and error to be

$$\begin{aligned}\tilde{\mathbf{u}}_k &= \mathbf{u}_k - \mathbf{u}_{k-1} \\ \tilde{\mathbf{e}}_k &= \mathbf{e}_k - \mathbf{e}_{k-1}\end{aligned}\quad (3.11)$$

Equation 3.9 reduces to a matrix form of the RLS equation.

$$\tilde{\mathbf{u}}_k = \tilde{\mathbf{e}}_k^T \mathbf{Q} \quad (3.12)$$

Although Equation 3.12 is in matrix form, it is important to remember that the estimate of each row of  $\mathbf{Q}$  is a unique difference equation of the associated control and error coefficients of their respective frequency. In other words, even though the frequency vector  $\mathbf{x}(n)$  is not found in Equation 3.12 the relationship between the third harmonic error and control coefficients remains linear. It is well known that the output of a linear system differs from the input only in magnitude and phase, therefore the system output  $y(t)$  can be written in terms of  $\mathbf{u}(t)$  as follows:

$$y_k(t) = |\mathbf{H}_k| A_k \cos(2\pi k f_o t + \alpha_k) + |\mathbf{H}_k| B_k \sin(2\pi k f_o t + \alpha_k) = C_k \cos(2\pi k f_o t) + D_k \sin(2\pi k f_o t) \quad (3.13)$$

where  $C_k$  and  $D_k$  reflect the magnitude and phase changes of the system on the input coefficients  $A_k$  and  $B_k$ . With the help of a trigonometric identity, Equation 3.13 can be written in a more convenient matrix form [Ref 7].

$$\begin{bmatrix} C_k \\ D_k \end{bmatrix} = |\mathbf{H}_k| \begin{bmatrix} \cos\alpha_k & -\sin\alpha_k \\ \sin\alpha_k & \cos\alpha_k \end{bmatrix} \begin{bmatrix} A_k \\ B_k \end{bmatrix} \quad (3.14)$$

Since  $\mathbf{H}_k$ ,  $\cos\alpha_k$  and  $\sin\alpha_k$  are scalars Equation 3.14 can be arranged in a recursive form similar to that of Equation 3.12 as follows

$$\begin{bmatrix} C_k \\ D_k \end{bmatrix} = \begin{bmatrix} A_k & -B_k \\ B_k & A_k \end{bmatrix} \begin{bmatrix} Y_k \\ Z_k \end{bmatrix} \quad (3.15)$$

where  $Y_k$  and  $Z_k$  represent the estimate for the product of the magnitude and phase change for the cosine and sine terms respectively of a given harmonic. Equation 3.15 represents the estimates of the coefficients for just a single harmonic of the system and can be thought of as a building block of the matrix RLS Equation 3.12.

Now all the needed information is available for implementation of a Kalman filter based RLS estimation [Ref 8, 9]. Figure 3.3 shows a block diagram representation of the system model with the estimation algorithm.

### 1. Considerations in Applying FFT to Harmonic Analysis

Since this algorithm emphasizes the use of Fourier coefficients, some aspects of using the Fast Fourier Transform (FFT) will be addressed. The FFT algorithm has

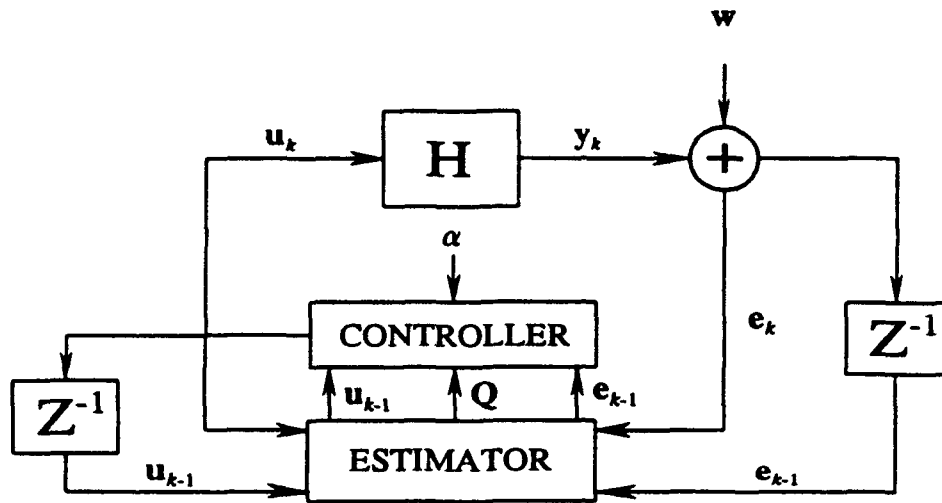

Figure 3.3 System Diagram with Estimation and Control

useful applications in power system networks, but can produce erroneous information if not applied correctly. Certain assumptions about the FFT must be understood to avoid false representation of the associated signal [Ref 7].

- The signal is stationary (constant magnitude).
- Each frequency in the signal is an integer multiple of the fundamental.
- The sampling frequency is equal to the number of samples times the fundamental frequency used in the algorithm.
- The sampling frequency meets Nyquist criteria.

#### D. SIMULATION RESULTS

In testing the optimal estimation algorithm the same harmonic noise components from the MSE in Chapter II were used. Since the impedance matrix of the system is estimated using RLS any linear transformation matrix for  $H$  can be used. For the purpose of this research a simple diagonal matrix with a linear progression from one to

forty-two was used. Figure 3.4 shows the control input to the line conditioner for the three highest offending harmonics. As in the MSE case, the values are reached asymptotically without any overshoot, thus showing the stability of the algorithm. The optimal estimation algorithm demonstrated superior robustness and stability compared to that of the MSE with respect to the linear predictor constant  $\alpha$ . The optimal estimator provided stable and consistent results for positive values of  $\alpha$  up to one. While individual harmonics in the MSE case were highly sensitive, and often grew unstable, with changes in  $\alpha$ .

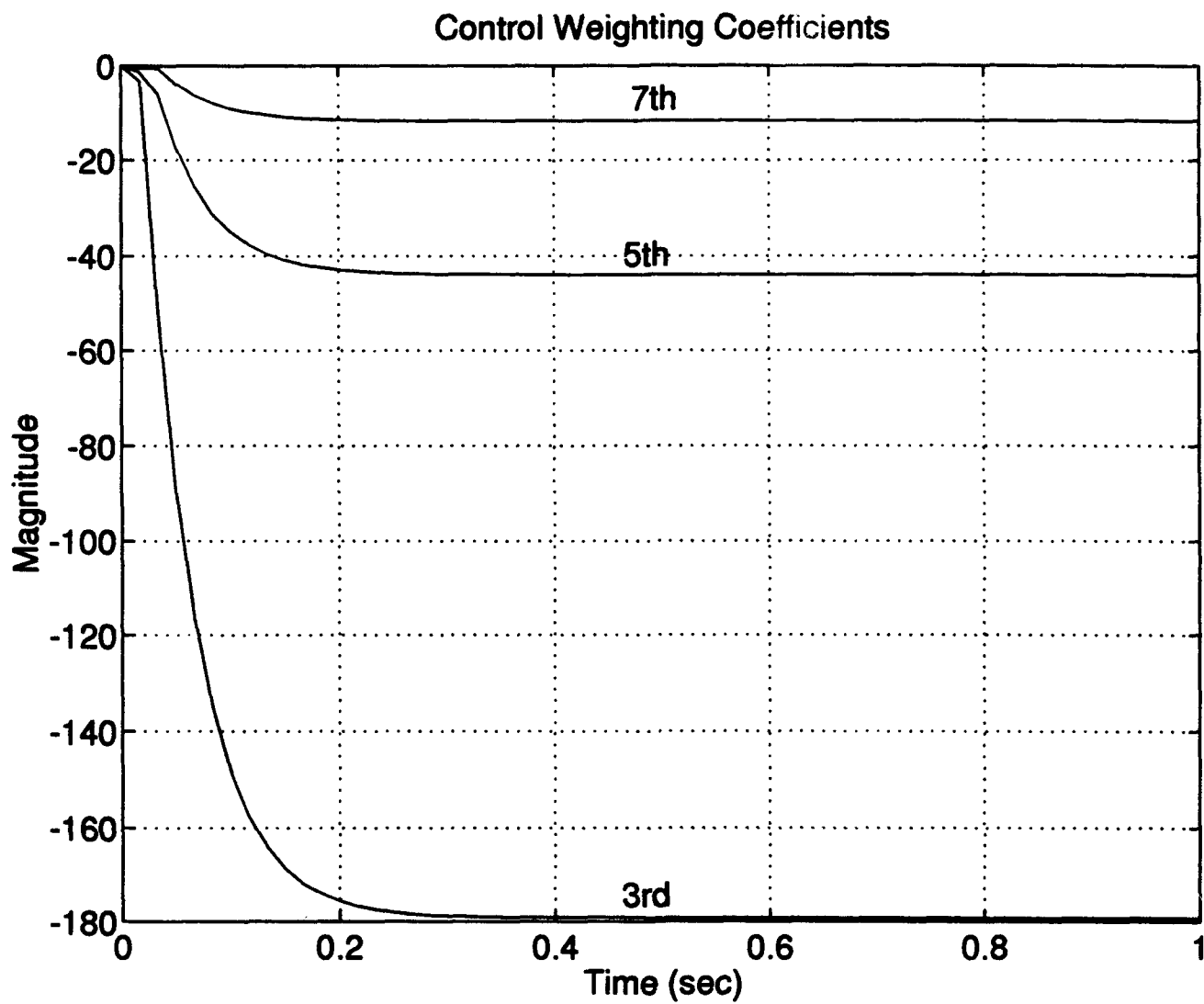

Figure 3.4 Control Input to Conditioner  $U_k$

Figure 3.5 shows the total harmonic distortion for several values of  $\alpha$  as a function of time.

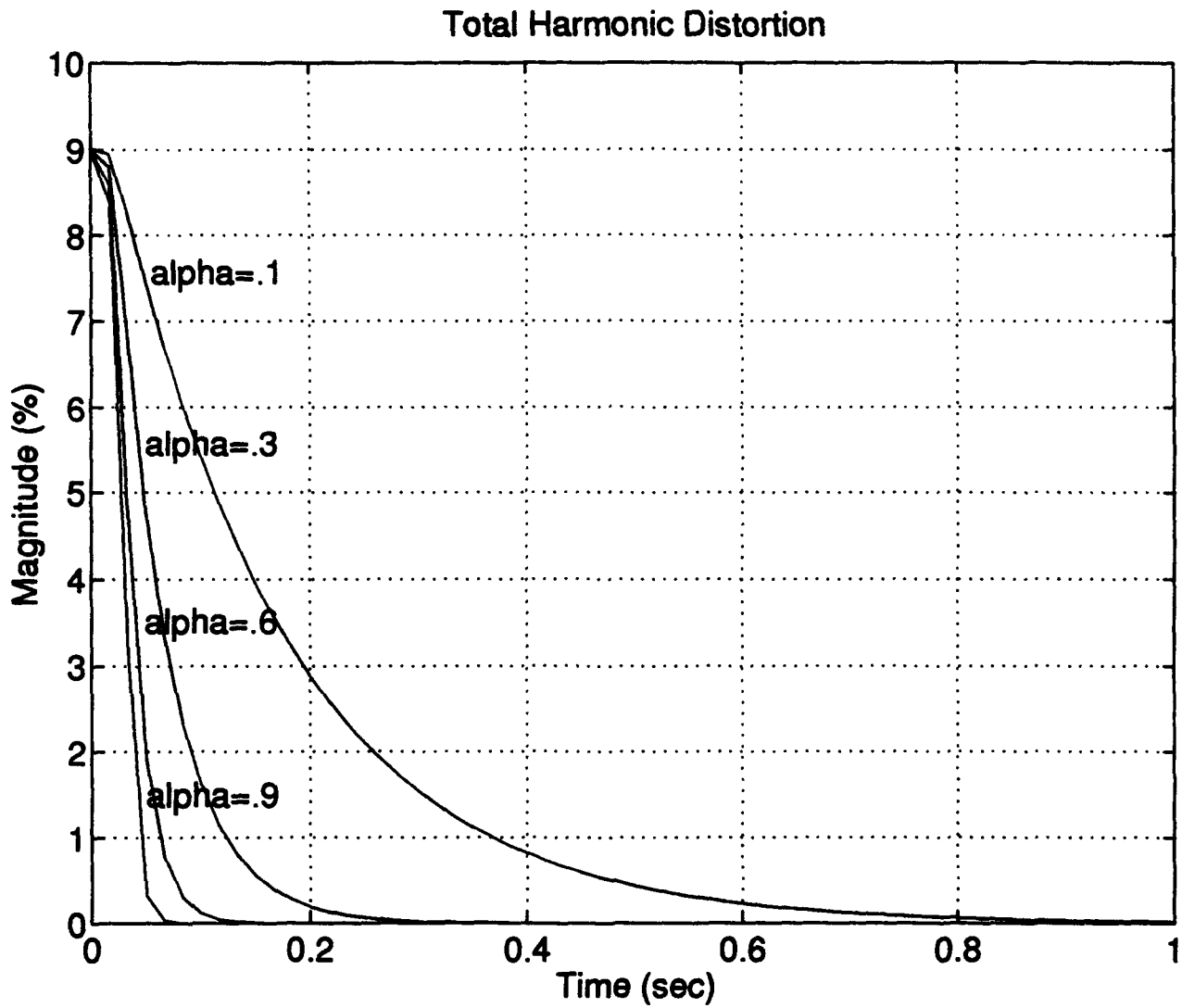

Figure 3.5 Total Harmonic Distortion (THD)

An additional piece of information provided by the optimal estimation algorithm is an adaptive estimate of the load impedance in the form of a matrix, **H**. Table 3.1 gives a break down of several of the actual and estimated matrix values along with their respective errors.

TABLE 3.1 ACTUAL AND ESTIMATED IMPEDANCE MATRIX COEFFICIENTS

Harmonic	3rd		5th		7th		9th		11th	
Actual	6	7	10	11	14	15	18	19	22	23
Estimated	6	7	10	11	14	15	18	19	22	23
Percent error	0.0	0.0	0.0	0.0	0.0	0.0	0.0	0.0	0.0	0.0

It is important to point out that only harmonic frequencies which are present in the offending noise will produce impedance coefficient estimates for the **H** matrix. This is simply the result of having no error to drive the RLS equation. If noise other than an odd harmonic of the fundamental were present an estimate of that impedance would appear in the matrix **H**.

## IV. CONCLUSIONS

### A. MSE ALGORITHM VS. OPTIMAL ESTIMATOR

When the load is linear, the optimal estimation algorithm proved to be much more effective in eliminating the associated harmonic noise and more robust with respect to changes in the gain of the linear prediction, as indicated in Equations 2.8 and 3.10. In addition to elimination of the harmonic noise, the optimal estimator provides a linear representation of the present system load in the form the impedance matrix  $H$ . The impedance information of the  $H$  matrix is beneficial in helping to determine the proper specifications of the active power line conditioner for the particular application.

### B. FUTURE RESEARCH

Because the optimal estimation algorithm uses the Fast Fourier Transform of the error signal it is currently limited to the linear case. Nonlinearities in the error signal present a difficult obstacle to overcome using standard Fouier transforms. Investigation into adapting the optimal estimation algorithm for nonlinear contingencies would be highly beneficial and would provide a better and more accurate model of the power line load impedance.

## APPENDIX A - (MATLAB) ADAPTIVE LINEAR MODEL

```

%%      THESIS PROGRAM 1
%%      JOEL ZUPFER
%%      17 MAY 93
%%      REVISED 18 NOVEMBER 93
%%      SIMULATION OF CIRCUIT FIGURE 2.3

clear
R      = 700;                %MODELLED RESISTOR VALUE (OHMS)
L      = 1.857;             %MODELLED INDUCTOR VALUE (HENERY'S)
f      = 60;                %FUNDAMENTAL FREQUENCY (HZ)
N      = 120;               %NUMBER OF SAMPLES PER CYCLE
lag    = 120;               %LAG FOR CALCULATION OF THE MSE
Cycle  = input('Number of cycles = '); %NUMBER OF CYCLES IN SIMULATION
check  = input('Number of cycles between gradient calculations = ');
                                        %CYCLES BETWEEN GRADIENT CALCULATIONS
totN   = N*round(Cycle/2)*check; %TOTAL NUMBER OF POINTS IN SIMULATION
Delay  = N*check;           %COUNTER FOR CHECKING ERROR VOLTAGE
accel  = 3e-7;              %ACCELERATION FACTOR
Wt     = [.51 .16 .056 .035 .025 .025 .02 .02 .015 .015]';
                                        %INITIAL WEIGHTS OF ODD HARMONICS
H      = [3 5 7 9 11 13 15 17 19 21]'; %ODD HARMONICS OF FUNDAMENTAL FREQUENCY
P      = pi*[1/3 1/4 1/5 3/2 4/2 5/2 1/6 2/6 3/6 8/6]'; %INITIAL PHASE OF ODD HARMONICS
mu     = H.^(-1).*accel;     %ACCELERATION FACTOR ADJUSTED FOR HARMONICS

%%%%%%%%%%%%%%%%%%%%%%%%%%%%%%%%%%%%%%%%%%%%%%%%%%%%%%%%%%%%%%%%%%%%%%%%%INITIALIZE PARAMETER MEMORY%%%%%%%%%%%%%%%%%%%%%%%%%%%%%%%%%%%%%%%%%%%%%%%%%%%%%%%%%%%%%%%%%%%%%%%%%
lh     = zeros(length(Wt),totN); %HARMONIC CURRENT
lc     = zeros(length(Wt),totN); %CONDITIONER CURRENT
lf     = zeros(1,totN); %FUNDAMENTAL CURRENT
Ve     = zeros(length(Wt),totN-1); %ERROR VOLTAGE
Vf     = zeros(1,totN-1); %FUNDAMENTAL VOLTAGE
Sh     = zeros(length(Wt),round(Cycle/2)+2); %HARMONIC SINE WEIGHTS
Ch     = zeros(length(Wt),round(Cycle/2)+2); %HARMONIC COSINE WEIGHTS
MSE    = zeros(length(Wt),Cycle+1); %MEAN SQUARE ERROR
thd    = zeros(1,Cycle+1); %TOTAL HARMONIC DISTORTION
GradSh = zeros(length(Wt),round(Cycle/2)); %GRADIENT OF SINE HARMONICS
GradCh = zeros(length(Wt),round(Cycle/2)); %GRADIENT OF COSINE HARMONICS

%%%%%%%%%%%%%%%%%%%%%%%%%%%%%%%%%%%%%%%%%%%%%%%%%%%%%%%%%%%%%%%%%%%%%%%%%INITIALCONDITIONS%%%%%%%%%%%%%%%%%%%%%%%%%%%%%%%%%%%%%%%%%%%%%%%%%%%%%%%%%%%%%%%%%%%%%%%%%
Sh(:,2) = ones(length(Wt),1)./H.*.1; %INITIAL WEIGHTING FACTOR FOR SINE HARMONIC
Ch(:,2) = ones(length(Wt),1)./H.*.1;%INITIAL WEIGHTING FACTOR FOR COSINE HARMONIC
lf(1) = 10*sqrt(2);
lf(2) = 9.9*sqrt(2); %PEAK CURRENT VALUES

```

```

%%%%%%%%%%%%%%%%%%%%%%%%%%%%%%%%%%%%%%%%%%%%%%%%%%%%%%%%%%%%%%%%%%%%%%%%%MAIN PROGRAM%%%%%%%%%%%%%%%%%%%%%%%%%%%%%%%%%%%%%%%%%%%%%%%%%%%%%%%%%%%%%%%%%%%%%%%%%
%%%%%%%%%%%%%%%%%%%%%%%%%%%%%%%%%%%%%%%%%%%%%%%%%%%%%%%%%%%%%%%%%%%%%%%%%BUS VOLTAGE WITH NO CONDITIONER CURRENT%%%%%%%%%%%%%%%%%%%%%%%%%%%%%%%%%%%%%%%%%%%%%%%%%%%%%%%%%%%%%%%%%%%%%%%%%
for k = 3:N-1
    sample = H.*2*pi*k/N; %DISCRETE SAMPLE POINT
    If(k) = 10*sqrt(2)*cos(2*pi*k/N); %FUNDAMENTAL CURRENT
    Ih(:,k) = Wt.*cos(sample + P); %HARMONIC CURRENT OF THE LOAD
    Ic(:,k) = (Sh(:,1).*sin(sample) + Ch(:,1).*cos(sample)); %CONDITIONER CURRENT
    Vf(k-1) = (If(k) - If(k-2))*(L*N*f/2) + If(k-1)*R; %FUNDAMENTAL VOLTAGE
    Ve(:,k-1) = (Ih(:,k) + Ic(:,k) - Ih(:,k-2) - Ic(:,k-2)).*(L*N*f/2) + (Ih(:,k-1) + Ic(:,k-1)).*R;
    %BUS ERROR VOLTAGE
end

MSE(:,1) = sqrt(mean(Ve(:,1:k-1).^2)); %MEAN SQUARE OF BUS ERROR VOLTAGE
thd(1) = sqrt(sum(max(Ve(:,2:k-1)).^2/2)*100/(max(Vf(2:k-1))/sqrt(2)));
%TOTAL HARMONIC DISTORTION
final = k+1; %STEP INDEX

%%%%%%%%%%%%%%%%%%%%%%%%%%%%%%%%%%%%%%%%%%%%%%%%%%%%%%%%%%%%%%%%%%%%%%%%%BUS VOLTAGE WITH CONDITIONER CURRENT%%%%%%%%%%%%%%%%%%%%%%%%%%%%%%%%%%%%%%%%%%%%%%%%%%%%%%%%%%%%%%%%%%%%%%%%%
for index = 1:round(Cycle/2)

    for k = final:Delay + final-1
        sample = H.*2*pi*k/N; %DISCRETE SAMPLE POINT
        If(k) = 10*sqrt(2)*cos(2*pi*k/N); %FUNDAMENTAL CURRENT
        Ih(:,k) = Wt.*cos(sample + P); %HARMONIC CURRENT OF THE LOAD
        Ic(:,k) = (Sh(:,index+1).*sin(sample) + Ch(:,index).*cos(sample));
        %CONDITIONER CURRENT
        Vf(k-1) = (If(k) - If(k-2))*(L*N*f/2) + If(k-1)*R; %FUNDAMENTAL VOLTAGE
        Ve(:,k-1) = (Ih(:,k) + Ic(:,k) - Ih(:,k-2) - Ic(:,k-2)).*(L*N*f/2) + (Ih(:,k-1) + Ic(:,k-1)).*R;
        %BUS ERROR VOLTAGE
    end

    MSE(:,2*index) = sqrt(mean(Ve(:,k-1-lag:k-1).^2)); %MEAN SQUARE OF ERROR VOLTAGE
    thd(2*index) = sqrt(sum(max(Ve(:,k-1-lag:k-1)).^2/2)*100/(max(Vf(k-1-lag:k-1))/sqrt(2)));
    %TOTAL HARMONIC DISTORTION
    final = k+1; %STEP INDEX
    GradSh(:,index) = (MSE(:,2*index) - MSE(:,2*index-1))./(Sh(:,index+1) - Sh(:,index));
    %SIN HARMONICS GRADIENT CALCULATION
    Sh(:,index+2) = Sh(:,index+1) - GradSh(:,index).*mu.*MSE(:,2*index);
    %PREDICTED SINE WEIGHTING FACTOR

    for k = final:Delay + final-1
        sample = H.*2*pi*k/N; %DISCRETE SAMPLE POINT
        If(k) = 10*sqrt(2)*cos(2*pi*k/N); %FUNDAMENTAL CURRENT
        Ih(:,k) = Wt.*cos(sample + P); %HARMONIC CURRENT OF THE LOAD
        Ic(:,k) = (Sh(:,index+1).*sin(sample) + Ch(:,index+1).*cos(sample));
        %CONDITIONER CURRENT
        Vf(k-1) = (If(k) - If(k-2))*(L*N*f/2) + If(k-1)*R; %FUNDAMENTAL VOLTAGE
        Ve(:,k-1) = (Ih(:,k) + Ic(:,k) - Ih(:,k-2) - Ic(:,k-2)).*(L*N*f/2) + (Ih(:,k-1) + Ic(:,k-1)).*R;
        %BUS ERROR VOLTAGE
    end
end

```

```

MSE(:,2*index+1)= sqrt(mean(Ve(:,k-1-lag:k-1).^2))'% MEAN SQUARE OF ERROR VOLTAGE
thd(2*index+1)   = sqrt(sum(max(Ve(:,k-1-lag:k-1)).^2/2)*100/(max(Vf(k-1-lag:k-1))/sqrt(2)));
                                                    % TOTAL HARMONIC DISTORTION

final           = k+1;
                                                    % STEP INDEX
GradCh(:,index) = (MSE(:,2*index+1) - MSE(:,2*index))./(Ch(:,index+1) - Ch(:,index));
                                                    % COSINE HARMONICS GRADIENT CALCULATION

Ch(:,index+2)   = Ch(:,index+1) - GradCh(:,index).*mu.*MSE(:,2*index+1);
                                                    % PREDICTED COSINE WEIGHTING FACTOR

```

end

```

%% %% %% %% %% %% %% %% %% %% %% %% %% PLOT SECTION %% %% %% %% %% %% %% %% %% %% %% %% %%
plot(Ve');title('Error Voltage');
xlabel('Samples (N)');ylabel('Voltage (V)');pause
plot(Ic');title('Conditioner Current');
xlabel('Samples (N)');ylabel('Current (I)');pause
plot(MSE');grid;title('Expectation');grid;
xlabel('Samples (N)');ylabel('Magnitude');pause
plot(Sh');title('Sin weighting coefficients');grid;
xlabel('Samples (N)');ylabel('Magnitude');pause
plot(Ch');title('Cosine weighting coefficients');grid;
xlabel('Samples (N)');ylabel('Magnitude');
plot(GradSh');grid;title('Grad Sh');
xlabel('Samples (N)');ylabel('Magnitude');pause
plot(GradCh');grid;title('Grad Ch');
xlabel('Samples (N)');ylabel('Magnitude');
plot(thd);title('Total Harmonic Distortion');grid
xlabel('Number of Cycles');ylabel('Percent (%)');

```

## APPENDIX B - (MATLAB) ADAPTIVE NONLINEAR MODEL

```

%% THESIS PROGRAM 2 (NON LINEAR LOAD)
%% JOEL ZUPFER
%% 28 MAY 93
%% REVISED 23 NOVEMBER 93
%% SIMULATION OF CIRCUIT FIGURE 2.4

clear
R      = 700;                %MODELLED RESISTOR VALUE (OHMS)
Li     = 1.857;             %MODELLED INDUCTOR VALUE (HENRY'S) INITIAL (NONLINEAR L)
f      = 60;                %FUNDAMENTAL FREQUENCY (HZ)
N      = 120;               %NUMBER OF SAMPLES PER CYCLE
lag    = 120;               %LAG FOR CALCULATION OF THE MSE
Cycle  = input('Number of cycles = '); %NUMBER OF CYCLES IN SIMULATION
check  = input('Number of cycles between gradient calculations = ');
                                           %CYCLES BETWEEN GRADIENT CALCULATIONS
totN   = N*Cycle*check      %TOTAL NUMBER OF POINTS IN SIMULATION
Delay  = N*check;           %COUNTER FOR CHECKING ERROR VOLTAGE
accel  = 3e-7;              %ACCELERATION FACTOR
Wt     = [.51 .16 .056 .035 .025 .025 .02 .02 .015 .015]';
                                           %INITIAL WEIGHTS OF ODD HARMONICS
H      = [3 5 7 9 11 13 15 17 19 21]'; %ODD HARMONICS OF FUNDAMENTAL FREQUENCY
P      = pi*[1/3 1/4 1/5 3/2 4/2 5/2 1/6 2/6 3/6 8/6]'; %INITIAL PHASE OF ODD HARMONICS
mu     = H.^(-1).*accel;    %ACCELERATION FACTOR ADJUSTED FOR HARMONICS

%%%%%%%%%%%%%%%%%%%%%%%%%%%%%%%%%%%%%%%%%%%%%%%%%%%%%%%%%%%%%%%%%%%%%%%%%
%% % % % % % % % % % % % % % % % INITIALIZE PARAMETER MEMORY % % % % % % % % % % % % % % %
lh      = zeros(length(Wt),totN);          %HARMONIC CURRENT
lc      = zeros(length(Wt),totN);          %CONDITIONER CURRENT
lf      = zeros(1,totN);                   %FUNDAMENTAL CURRENT
Ve      = zeros(length(Wt),totN-1);        %BUS VOLTAGE
Sh      = zeros(length(Wt),round(Cycle/2)+2); %HARMONIC SIN WEIGHTS
Ch      = zeros(length(Wt),round(Cycle/2)+2); %HARMONIC COS WEIGHTS
MSE     = zeros(length(Wt),Cycle+1);       %MEAN SQUARE ERROR
thd     = zeros(1,Cycle+1);                %TOTAL HARMONIC DISTORTION
GradSh  = zeros(length(Wt),Cycle);         %GRADIENT OF SIN HARMONICS
GradCh  = zeros(length(Wt),Cycle);         %GRADIENT OF COS HARMONICS

%%%%%%%%%%%%%%%%%%%%%%%%%%%%%%%%%%%%%%%%%%%%%%%%%%%%%%%%%%%%%%%%%%%%%%%%%
%% % % % % % % % % % % % % % % % INITIALCONDITIONS % % % % % % % % % % % % % % %
Sh(:,2) = ones(length(Wt),1)./H*.1; %INITIAL WEIGHTING FACTOR FOR SINE HARMONICS
Ch(:,2) = ones(length(Wt),1)./H*.1;%INITIAL WEIGHTING FACTOR FOR COSINE HARMONICS
lf(1)   = 10*sqrt(2);
lf(2)   = 9.9*sqrt(2);                  PEAK CURRENT VALUES

```

%%MAIN PROGRAM%%

%%BUS VOLTAGE WITH NO CONDITIONER CURRENT%%  
for k = 3:N-1

sample = H.\*2\*pi\*k/N; %DISCRETE SAMPLE POINT  
If(k) = 10\*sqrt(2)\*cos(2\*pi\*k/N); %FUNDAMENTAL CURRENT  
lh(:,k) = Wt.\*cos(sample + P) %HARMONIC CURRENT OF THE LOAD  
Ic(:,k) = Sh(:,1).\*sin(sample) + Ch(:,1).\*cos(sample); %CONDITIONER CURRENT  
L = Li \*ones(10,1) ./ (1 + abs((lh(:,k-1)+Ic(:,k-1))/10)); %NONLINEAR INDUCTANCE  
Vf(k-1) = (If(k) - If(k-2))\*(Li\*N\*f/2) + If(k-1)\*R; %FUNDAMENTAL VOLTAGE  
Ve(:,k-1) = (lh(:,k) + Ic(:,k) - lh(:,k-2) - Ic(:,k-2)).\*(L\*N\*f/2) + (lh(:,k-1) + Ic(:,k-1)).\*R;  
%BUS VOLTAGE

end

MSE(:,1) = sqrt(mean(Ve(:,1:k-1)'.^2)); %MEAN SQUARE OF ERROR VOLTAGE  
thd(1) = sqrt(sum(max(Ve(:,2:k-1)').^2/2)\*100/(max(Vf(2:k-1))/sqrt(2)));  
%TOTAL HARMONIC DISTORTION  
final = k+1; %STEP INDEX

%%BUS VOLTAGE WITH CONDITIONER CURRENT%%  
for index = 2:Cycle

for k = final:Delay+final-1  
sample = H.\*2\*pi\*k/N; %DISCRETE SAMPLE POINT  
If(k) = 10\*sqrt(2)\*cos(2\*pi\*k/N); %FUNDAMENTAL CURRENT  
lh(:,k) = Wt.\*cos(sample + P); %HARMONIC CURRENT OF THE LOAD  
Ic(:,k) = Sh(:,index).\*sin(sample) + Ch(:,index-1).\*cos(sample);  
%CONDITIONER CURRENT  
L = Li \*ones(10,1) ./ (1 + abs((lh(:,k-1)+Ic(:,k-1))/10)); %NONLINEAR INDUCTANCE  
Vf(k-1) = (If(k) - If(k-2))\*(Li\*N\*f/2) + If(k-1)\*R; %FUNDAMENTAL VOLTAGE  
Ve(:,k-1) = (lh(:,k) + Ic(:,k) - lh(:,k-2) - Ic(:,k-2)).\*(L\*N\*f/2) + (lh(:,k-1) + Ic(:,k-1)).\*R;  
%BUS VOLTAGE

end

MSE(:,2\*index-2) = sqrt(mean(Ve(:,k-1-lag:k-1)'.^2)); %MEAN SQUARE OF ERROR VOLTAGE  
thd(2\*index) = sqrt(sum(max(Ve(:,k-1-lag:k-1)').^2/2)\*100/(max(Vf(k-1-lag:k-1))/sqrt(2)));  
%TOTAL HARMONIC DISTORTION  
final = k+1; %STEP INDEX  
GradSh(:,index) = (MSE(:,2\*index-2) - MSE(:,2\*index-3))./(Sh(:,index) - Sh(:,index-1));  
%SINE GRADIENT CALCULATION  
Sh(:,index+1) = Sh(:,index) - GradSh(:,index).\*mu.\*MSE(:,2\*index-2);  
%PREDICTED SINE WEIGHTING FACTOR



## APPENDIX C - (MATLAB) OPTIMAL ESTIMATION MODEL

```

%% THESIS PROGRAM 3
%% JOEL ZUPFER
%% 1 JUNE 93
%% REVISED 30 NOVEMBER 93
%% SIMULATION OF CIRCUIT FIGURE 2.3

clear
R = 700; %MODELED RESISTOR VALUE (OHMS)
L = 1.857; %MODELED INDUCTOR VALUE (HENERY'S)
f = 60; %FUNDAMENTAL FREQUENCY (HZ)
Wt = [0 0 .51 0 .16 0 .056 0 .035 0 .025 0 .025 0 .02 0 .02 0 .015 0 .015];
%WEIGHTS OF THE HARMONICS INITIAL CONDITION
H = [1 2 3 4 5 6 7 8 9 10 11 12 13 14 15 16 17 18 19 20 21];
%HARMONICS OF FUNDAMENTAL FREQUENCY
P = pi*[0 0 1/3 0 1/4 0 1/5 0 3/2 0 4/2 0 5/2 0 1/6 0 2/6 0 3/6 0 8/6];
%PHASE OF HARMONICS INITIAL CONDITION
M = 2*length(H); %NUMBER OF SAMPLE POINTS/PERIOD
ALPHA = 0.75; %WEIGHTING FACTOR FOR CONTROL DETERMINATION
Cycle = input('Number of cycles = '); %NUMBER OF CYCLES IN SIMULATION

%% % % % % % % % % % % % INITIALIZE PARAMETER MEMORY % % % % % % % % % % %

D = [1:42]; %DIAGONAL ELEMENTS OF H
HL = diag(D); %TRANSFER MATRIX OF SYSTEM LOAD
Qhat = eye(M)*.1; %INITIAL GUESS FOR INVERSE OF H
Q = zeros(2*length(H),2*length(H)); %INITIAL VALUE OF Q MATRIX
theta0 = zeros(1,1); %THE ESTIMATION FOR THE DC COMPONENT
theta42 = zeros(1,1); %THE ESTIMATION FOR THE 21st HARMONIC
theta = zeros(2,2*(length(H)-1)); %THE ESTIMATION OF THE SYSTEM IMPEDANCE
G0 = 50; %INITIAL VALUE OF GAIN MATRIX(MEASURE OF UNCERTAINTY)
G42 = 50; %INITIAL VALUE OF GAIN MATRIX
G = [ones(2*H(length(H)-1),1),zeros(2*H(length(H)-1),2),ones(2*H(length(H)-1),1)]*50;
%INITIAL VALUE OF GAIN MATRIX
If = zeros(1,M); %INITIALIZE THE FUNDAMENTAL CURRENT
Vf = zeros(1,M); %INITIALIZE THE FUNDAMENTAL VOLTAGE
Ve = zeros(1,M); %INITIALIZE THE NOISE VECTOR
X = zeros(M,M); %INITIALIZE THE MATRIX OF SUM OF COS & SIN
E = zeros(M,Cycle); %ACTUAL ERROR
Ek = zeros(M,Cycle); %PERIODIC ERROR
Ehat = zeros(M,Cycle); %ESTIMATED PERIODIC ERROR
Uk = zeros(M,Cycle); %PERIODIC CONTROL INPUT
Uhat = zeros(M,Cycle); %ESTIMATED PERIODIC CONTROL INPUT
Yk = zeros(M,Cycle); %PERIODIC SYSTEM OUTPUT
thd = zeros(1,Cycle); %TOTAL HARMONIC DISTORTION

```





```

(function w = fft trig(x)
% w=fft trig(x)
% it computes the fft coefficients of the vector x
% in trigonometric form.
%  $x(n) = w_1 + w_2 \cos(2\pi n/N) + w_3 \sin(2\pi n/N) + w_4 \cos(4\pi n/N) + w_5 \sin(4\pi n/N) + \dots$ 
%  $\dots + w_{(N-2)} \cos(2\pi(N/2-1)n/N) + w_{(N-1)} \sin(2\pi(N/2-1)n/N) + w_{(N)} \cos(\pi n)$ ;
% where  $N = \text{length}(x)$ , assumed to be a power of 2 (if not  $x$  is padded with 0's)
X = fft(x);
N = length(X);
Xr = real(X);
Xi = imag(X);
w(1) = Xr(1)/N;
k = 1:(N/2)-1;
    w(2*k) = 2*Xr(2:(N/2))/N;
    w(2*k+1) = -2*Xi(2:(N/2))/N;
    w(N) = Xr((N/2)+1)/N;
end % fft trig

```

```

function x=ifft trig(w)
% x=ifft trig(w)
% compute time sequence x from trig. coefficients w.
% See FFTRIG
N = length(w);
Xr(1) = w(1)*N;
Xi(1) = 0;
k = 1:(N/2)-1;
    Xr(2:(N/2)) = N*w(2*k)/2;
    Xi(2:(N/2)) = -N*w(2*k+1)/2;
    Xr((N/2)+1) = N*w(N);
    Xi((N/2)+1) = 0;
    X = Xr + sqrt(-1)*Xi;
    X(N-k+1) = conj(X(k+1));
    x = real(fft(X));
end % ifft trig

```

## LIST OF REFERENCES

1. Ashton, R. W., Emanuel, A. E., "An Adaptive Estimation Method for Harmonic Voltage Minimization by Means of Line Conditioners," IEEE Trans. on Power Delivery, Vol 6, No.4, pp. 1906-1911, October 1991.
2. Emanuel, A. E., "Powers in Nonsinusoidal Situations, A Review of Definitions and Physical Meaning," IEEE Trans. on Power Delivery, Vol 5, No.3, pp. 1377-1389, July 1990.
3. Grady, W. M., Samotyj, M. J., Noyola, A. H., "Survey of Active Power Line Conditioning Methodologies," IEEE PES WM 048-9 PWRD.
4. Tironi, E., Ubezio, G., Zanibelli, D., "New Prospects of a High Frequency Supply System for Discharge Lamps with Centralized AC/DC Conversion," Proceedings of ICHPS IV, pp. 304-308, Budapest, Hungary, October 1990.
5. Emanuel, A. E., Yang, M., "On the Optimum Power Factor Correction in Nonsinusoidal Systems," IEEE Trans. on Power Delivery, Vol 8, No.1, pp. 393-399, January 1993.
6. Widrow, B., and Stearns, S. D., *Adaptive Signal Processing*, pp. 15-24, Prentice-Hall, Inc., 1985.
7. Girgis, A. A., Chang, W. B., Makram, E. B., "A Digital Recursive Measurement Scheme for on-line Tracking of Power System Harmonics," IEEE Trans. on Power Delivery, Vol 6, No. 3, pp. 1153-1160, July 1991.
8. Johansson, R., *System Modeling and Identification*, pp. 75-96, Prentice-Hall, Inc., 1993
9. Class Notes, Naval Post Graduate School, EC4360, Spring Quarter, 1993.

## INITIAL DISTRIBUTION LIST

	No. Copies
1. Defense Technical Information Center Cameron Station Alexandria VA 22304-6145	2
2. Library, Code 52 Naval Postgraduate School Monterey CA 93943-5101	2
3. Department Chairman, Code EC Department of Electrical and Computer Engineering Naval Post Graduate School Monterey, California 93943-5121	1
4. Professor Robert W. Ashton, Code EC/Ah Department of Electrical and Computer Engineering Naval Post Graduate School Monterey, California 93943-5121	1
5. Professor Roberto Cristi, Code EC/Cx Department of Electrical and Computer Engineering Naval Post Graduate School Monterey, California 93943-5121	1
6. Professor Harold Titus, Code EC/Ts Department of Electrical and Computer Engineering Naval Post Graduate School Monterey, California 93943-5121	1
7. Lt. Joel E. Zupfer 1852 Sleva Grande Drive Atlantic Beach, Florida 32233	2