

2

1a. REPORT SECURITY CLASSIFICATION unclassified		3. DISTRIBUTION/AVAILABILITY OF REPORT distribution for public release; distribution unlimited.	
2a. SECURITY CLASSIFICATION AUTHORITY ELECTE		2b. DECLASSIFICATION/DOWNGRADING SCHEDULE APR 21 1994	
4. PERFORMING ORGANIZATION REPORT NUMBER(S) N/A		5. MONITORING ORGANIZATION REPORT NUMBER(S) AFOSR-TR- 94 0203	
6a. NAME OF PERFORMING ORGANIZATION Texas Engineering Experiment Station		7a. NAME OF MONITORING ORGANIZATION AFOSR/NE	
6b. ADDRESS (City, State and ZIP Code) Texas A&M University 334 Wisenbaker Eng. Research Center College Station, TX 77843-3128		7b. ADDRESS (City, State and ZIP Code) Bldg. 410 Bolling AFB Washington DC 20332-6448	
8a. NAME OF FUNDING/SPONSORING ORGANIZATION AFOSR		8b. OFFICE SYMBOL (If applicable) PRD	
9. PROCUREMENT INSTRUMENT IDENTIFICATION NUMBER AFOSR-91-0417		10. SOURCE OF FUNDING NOS	
8c. ADDRESS (City, State and ZIP Code) Bldg. 410 Bolling AFB Washington DC 20332-6448		PROGRAM ELEMENT NO. 61102F	PROJECT NO. 1601
11. TITLE (Include Security Classification) (u) Spectral-Domain Optical Processing Tech.		TASK NO. 10	WORK UNIT NO.
12. PERSONAL AUTHOR(S) Henry F. Taylor			
13a. TYPE OF REPORT Annual	13b. TIME COVERED FROM 9/30/91 TO 3/31/93	14. DATE OF REPORT (Yr., Mo., Day) 4/20/93	15. PAGE COUNT 26
16. SUPPLEMENTARY NOTATION			
17. COSATI CODES		18. SUBJECT TERMS (Continue on reverse if necessary and identify by block number)	
FIELD	GROUP	SUB. GR.	
		Nonlinear optics communication networks quantum well	
19. ABSTRACT (Continue on reverse if necessary and identify by block number) Optical techniques for spectral domain processing (SDP) have been investigated. A computer model for the design of nonlinear devices for frequency mixing in multiquantum well (MQW) materials has been developed. The model has been used to calculate nonlinear coefficients for mixing of pump lasers at wavelengths near 1.3um and 1.55 um to produce an output near 8.05um. A device length for conversion of 0.6 mm is predicted for a pump power density of 10 ⁶ W/cm ² . A quasi-phase-matching scheme for obtaining high conversion efficiency in a dispersive semiconductor material has been devised. An N-dimensional hyper cube network configuration making use of the frequency conversion devices has been propose. The scheme allows for all-optical transmission of data from source node to destinatin node without optical-to-electrical conversion.			
20. DISTRIBUTION/AVAILABILITY OF ABSTRACT UNCLASSIFIED/UNLIMITED <input checked="" type="checkbox"/> SAME AS RPT. <input type="checkbox"/> DTIC USERS <input type="checkbox"/>		21. ABSTRACT SECURITY CLASSIFICATION unclassified	
22a. NAME OF RESPONSIBLE INDIVIDUAL Craig		22b. TELEPHONE NUMBER (Include Area Code) 202 767-4931	22c. OFFICE SYMBOL NE

AFOSR-TR- 94 0203

Approved for public release;
distribution unlimited.

SPECTRAL-DOMAIN OPTICAL PROCESSING TECHNIQUES

Henry F. Taylor
Texas Engineering Experiment Station
Department of Electrical Engineering
Texas A&M University
College Station, Texas 77843

20 April 1993

Annual Report for Period 1 30 September 1991 - 31 March 1993

distribution is unlimited

Prepared for; AFOSR/NE
Bolling AFB, DC 20332-6448

LITIC QUALITY INSPECTED 3

94-12046



94 4 20 120

SPECTRAL-DOMAIN OPTICAL PROCESSING TECHNIQUES

ABSTRACT

Optical techniques for spectral domain processing (SDP) have been investigated. A computer model for the design of nonlinear devices for frequency mixing in multi-quantum well (MQW) materials has been developed. The model has been used to calculate nonlinear coefficients for mixing of pump lasers at wavelengths near 1.3 μm and 1.55 μm to produce an output near 8.05 μm . A device length for conversion of 0.6 mm is predicted for a pump power density of 10^6 W/cm^2 . A quasi-phase-matching scheme for obtaining high conversion efficiency in a dispersive semiconductor material has been devised. An N-dimensional hypercube network configuration making use of the frequency conversion devices has been proposed. The scheme allows for all-optical transmission of data from source node to destination node without optical-to-electrical conversion.

Accession For	
NTIS CRA&I	<input checked="" type="checkbox"/>
DTIC TAB	<input type="checkbox"/>
Unannounced	<input type="checkbox"/>
Justification	
By	
Distribution /	
Availability Codes	
Dist	Avail and/or Special
A-1	

SPECTRAL-DOMAIN OPTICAL PROCESSING TECHNIQUES

Table of Contents

1	Background	1
2	Technical Objective	9
3	Device Design	9
4	Device Fabrication	13
5	Network Application	17
6	Conclusions	18
7	References	21

SPECTRAL-DOMAIN OPTICAL PROCESSING TECHNIQUES

Background

A nonlinear interaction between two or more information carriers is required to perform most useful logic and computational functions. The use of optical carriers for high-speed digital processing is attractive from the standpoint of high carrier frequency, low propagation delay, and the potential for parallel processing. Most optical logic schemes which have been proposed have made use of interactions in which there is a nonlinear relation between the intensities of two optical inputs. However, due to materials limitations and the lack of architectures which can take advantage of the inherent bandwidth of the optical carriers, such schemes have not proven competitive with conventional all electronic computing methods.

Dr. Alan Craig of AFOSR has proposed a new approach to optical processing based upon nonlinear interactions between optical carriers in the frequency domain. A computing device using this approach can be termed a "spectral domain processor" (SDP). One approach to the SDP would utilize difference frequency mixing (DFM) and/or sum-frequency mixing (SFM) as the fundamental interactions; i. e., two carriers at frequencies f_1 and f_2 would mix to produce an output at a frequency $f_3 = f_1 \pm f_2$.

Key considerations in the design of an SDP include the selection of suitable light sources and nonlinear materials, the design of logic and computing elements, and system architectures. The first of these issues, light source selection, is reasonably straightforward. Two semiconductor alloy systems have recently been developed to provide efficient, reliable sources of coherent radiation at near-infrared wavelengths: the GaAlAs system (.78-.86 μm) and the InGaAsP system (1.2-1.6 μm). The active layer composition for a particular laser determines its emission wavelength within the spectral range. Furthermore, GaAlAs lasers can efficiently pump Nd:YAG solid-state lasers to provide single-frequency emission at the intermediate wavelength of 1.06 μm . Wavelengths available from DFM and SFM using various combinations of these lasers are summarized below:

laser 1	laser 2	output wavelength range (μm)	
		DFM	SFM
GaAlAs	InGaAsP	1.5-3.0	.47-.56
Nd:YAG	InGaAsP	3.1-9.1	.56-.64
GaAlAs	Nd:YAG	3.0-4.6	.45-.47
InGaAsP	InGaAsP	> 4.8	.60-.80

Thus, a wide range of wavelengths in the visible and near-infrared spectral regions is possible using DFM and SFM. Threshold currents of less than 1 mA and wall-plug efficiencies in excess of 50% have been obtained in both GaAlAs and InGaAsP laser systems. More recently, InGaAs laser diodes which operate reliably at room temperature at wavelengths near 1 μm have been reported. When InGaAs lasers are commercially available, they can be used to further extend the range of pump wavelengths for DFM and SFM.

Of course, suitable nonlinear materials are needed for SDP to be practical. The material used for mixing the three optical frequencies should have a very large nonlinear coefficient d_{ij} and should be suitable for phase-matching at the pump frequencies f_1 and f_2 and the sum or difference frequency f_3 . Conventional nonlinear infrared materials such as GaAs or CdTe do not meet these criteria. However, epitaxially-grown layered semiconductors known as multiple quantum well (MQW) materials are predicted to have very large nonlinear optical coefficients [1]. Experimentally, second harmonic generation in GaAlAs MQWs using a 10.6 μm CO_2 pump laser has been reported [2,3].

The quantum wells are layers of relatively low energy gap sandwiched between barrier layers with larger energy gaps. Electrons or holes trapped in these wells occupy discrete quantum-mechanical energy eigenstates. The optical nonlinearities result from electric dipole transitions of charged carriers between the ground state and excited states of the wells, which are termed intrasubband transitions. Large, resonantly enhanced nonlinearities occur when these transition energies are near photon energies of the interacting light waves.

The symmetry of the quantum wells is a key consideration in the design of MQW devices. Energy level diagrams and wave functions for symmetric and asymmetric wells are illustrated in Fig. 1. The nonlinear coefficient d_{33} is proportional to the product of dipole matrix elements $y_{ab}y_{bc}y_{ac}$. For the symmetric well, the wave functions u_a and u_c are symmetric with respect to the center of the well. Since the electric dipole perturbation is proportional to y , which is antisymmetric, then $y_{ac} = 0$ for the symmetric well. In this case, the nonlinear coefficient vanishes. Thus, an asymmetric well, for which in general $y_{ac} \neq 0$, is needed for the nonlinear device. This is equivalent to the requirement that a nonlinear crystal have no center of inversion symmetry. Asymmetric well structures are also needed for linear electrooptic modulators in quantum well materials [4].

A configuration for DFM in MQWs is illustrated in Fig. 2. Light is coupled into a planar waveguide of the MQW material. The polarization for each of the three frequencies is oriented in the y -direction (perpendicular to the well interfaces) as dictated by the need for off-resonance excitation of dipole transitions in the wells [1-3]. The nonlinear interaction transfers energy from the pump wave at the frequency f_1 into the pump wave at lower frequency f_2 ($f_1 > f_2$) and the wave at the difference frequency f_3 .

GaAlAs is by far the most commonly used material system for quantum well device studies. The epitaxial techniques for producing the layers are well developed, and the materials are transparent in the infrared to 15 μm . However, other materials might ultimately prove more effective for DFM at GaAlAs and InGaAsP laser wavelengths. The well depth for electrons in GaAlAs is limited to about 1.0 eV, with GaAs wells and AlAs barriers, which constrains the available range of resonance frequencies in the device design. Other materials systems which provide larger well depths might thus be advantageous for the DFM application. One interesting possibility is the GaAlAsP alloy system, with GaAsP wells and AlAsP barriers. The $\Gamma_1^c - \Gamma_{15}^v$ energy gap is 5.12 eV in AlP and 2.89 eV in GaP, giving an energy gap difference of 2.23 eV [5]. By contrast, the $\Gamma_1^c - \Gamma_{15}^v$ energy gap is 3.06 eV in AlAs and 1.52 eV in GaAs, so that the energy gap difference is 1.54 eV. If we assume that the well depth for electrons is proportional to the energy gap

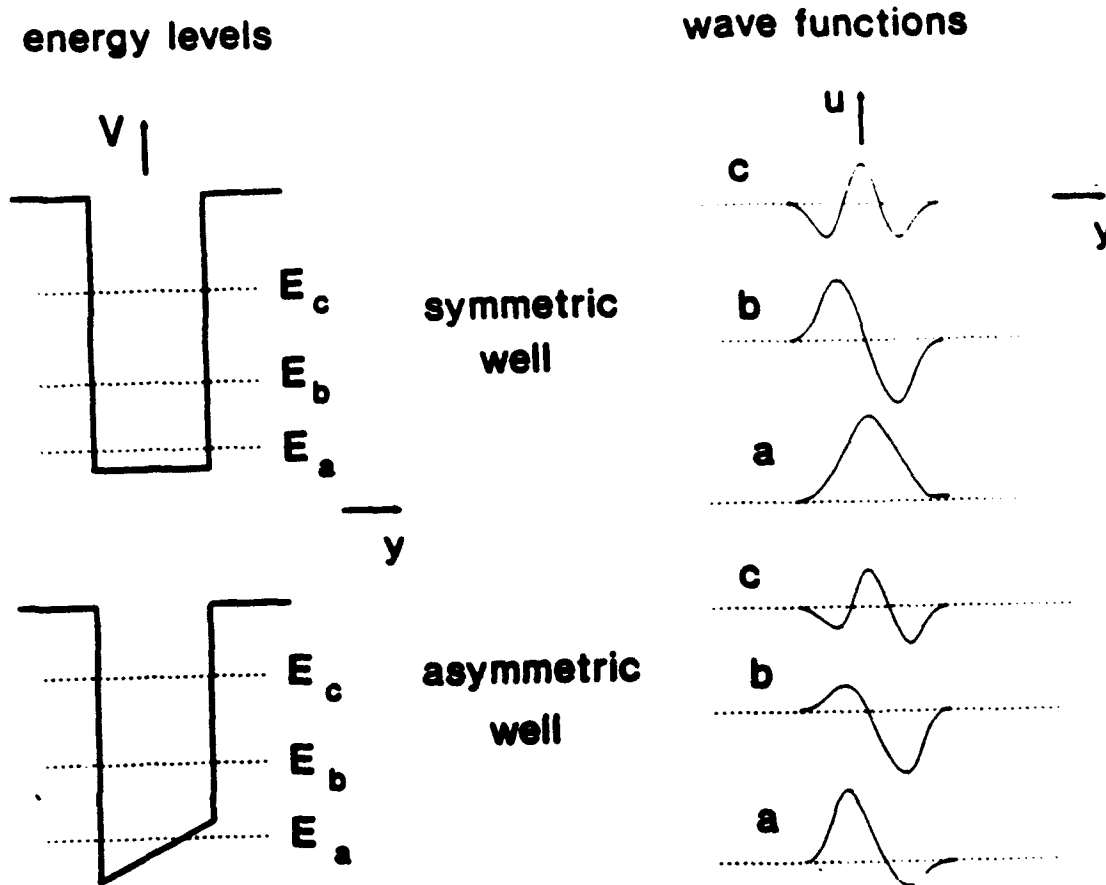

Fig. 1. A comparison of energy levels and wave functions for symmetric and asymmetric quantum wells. The matrix element $y_{uc} = 0$ for the symmetric well, so that the nonlinear coefficient vanishes. The asymmetric well, by contrast, can show large nonlinearities.

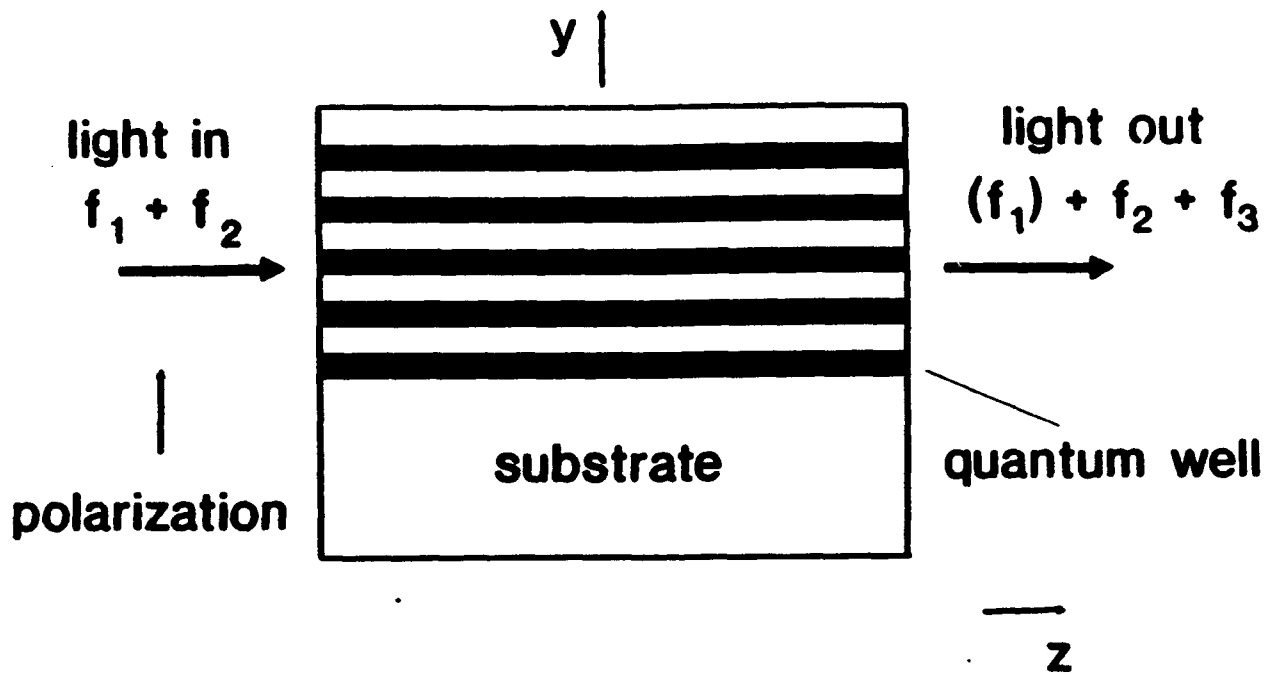

Fig. 2. A planar waveguide configuration for DFM in a MWQ material. Power is transferred from the pump at frequency f_1 to the pump at frequency f_2 and the difference-frequency wave at frequency f_3 .

difference, then the well depth will be an decreasing function of the parameter x in the alloy system $\text{Ga}_x\text{Al}_{1-x}\text{AsP}$. Thus, it may be possible to get well depths considerably greater than 1 eV in the GaAlAsP system. Furthermore, lattice matching should be readily obtained, since the lattice constant for AlP (5.463 Angstroms) is very close to that for GaP (5.451 Angstroms) [6]. This parallels the excellent lattice match between GaAs (5.654 Angstroms) and AlAs (5.661 Angstroms) [6].

With the large nonlinear coefficients obtainable with MQW materials, efficient mixing can be obtained in a short distance if sufficiently high power densities are maintained at the pump laser frequencies f_1 and f_2 . The best way of achieving this is to perform the nonlinear conversion in a channel waveguide of the MQW material, as in Fig. 3. The waveguide would be designed to provide two-dimensional confinement at all three optical frequencies, so that efficient mixing is obtained over the entire length of the device. Furthermore, the waveguides could serve as interconnections between processing elements.

Another issue is how to achieve the phase matching needed for efficient nonlinear conversion. The requirement is that the propagation vector for the optical wave at the higher pump frequency f_1 be equal to the sum of the propagation vectors for the other two frequencies. The ability to meet this requirement is determined by the dispersion characteristics of the MQW waveguide, which includes the "background" dispersion of the bulk materials, quantum well (QW) dispersion due to the dipole transitions in the wells, and waveguide dispersion. The refractive index change resulting from the quantum well transition can be quite large (of the order of unity for doping levels of $10^{18}/\text{cm}^3$ in the wells) for laser frequencies close to the dipole transition frequency (absorption line). Furthermore, the index change is positive (negative) for optical frequencies below (above) the transition frequency. However, to obtain such a large QW dispersion it is necessary to choose an operating wavelength near the peak of the absorption line, resulting in strong attenuation at that wavelength.

Two possible well designs are illustrated in Fig. 4. Here it is assumed that the laser photon energies are in the vicinity of 1.5 eV for laser 1 (a GaAlAs laser) and 0.95 for laser 2 (an InGaAsP laser). The first configuration would correspond to a relatively narrow well, with only one bound state. The transitions contributing to the nonlinearity are from the ground state to continuum states (y_{ab} and y_{ac}) and between continuum states (y_{bc}). The well parameters are chosen such that the ground-state-to-continuum absorption is bracketed in energy by the photon pump energies E_1 and E_2 . The second configuration corresponds to a wider well with 3 bound states. In that case the first absorption peak is near the photon difference energy E_3 and the second absorption peak absorption is bracketed in energy by the photon pump energies E_1 and E_2 .

The design of logic and computational elements for SDP has received little attention to date. However, it is clear that design rules will differ considerably from those employed in conventional electronic and optical processing schemes. Two examples with single-mode channel waveguides containing frequency mixing sections are given in Figs. 5 and 6. In the AND gate of Fig. 5, two SFM waveguide sections are used in conjunction with frequency-selective directional couplers. Two input waveguide ports and one output ports are provided: light at the frequency f_2 represents a "one", while no light at that frequency represents a "zero". The illustrations in Fig. 5

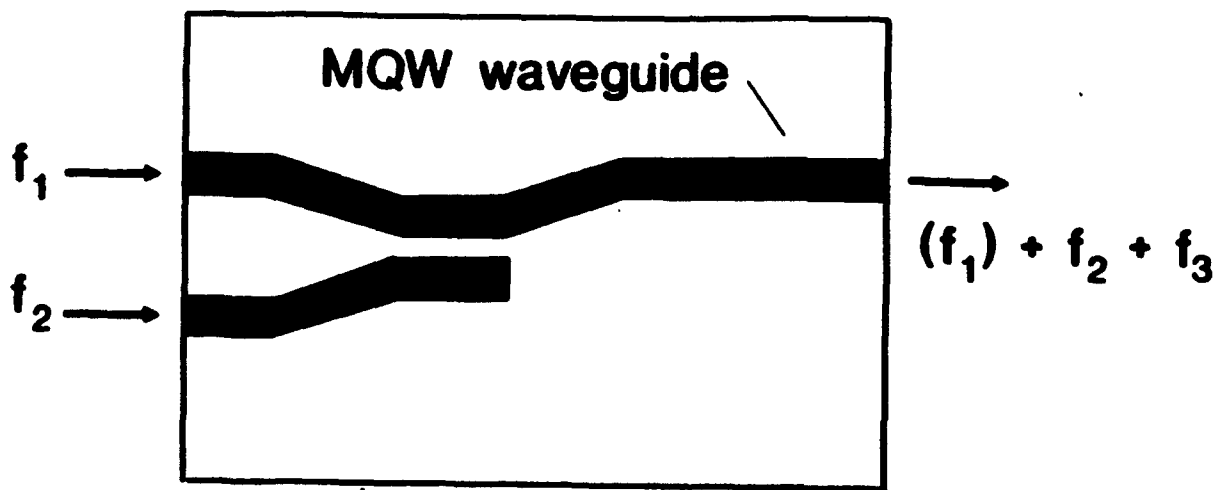

Fig. 3. Channel waveguide configuration for DFM.

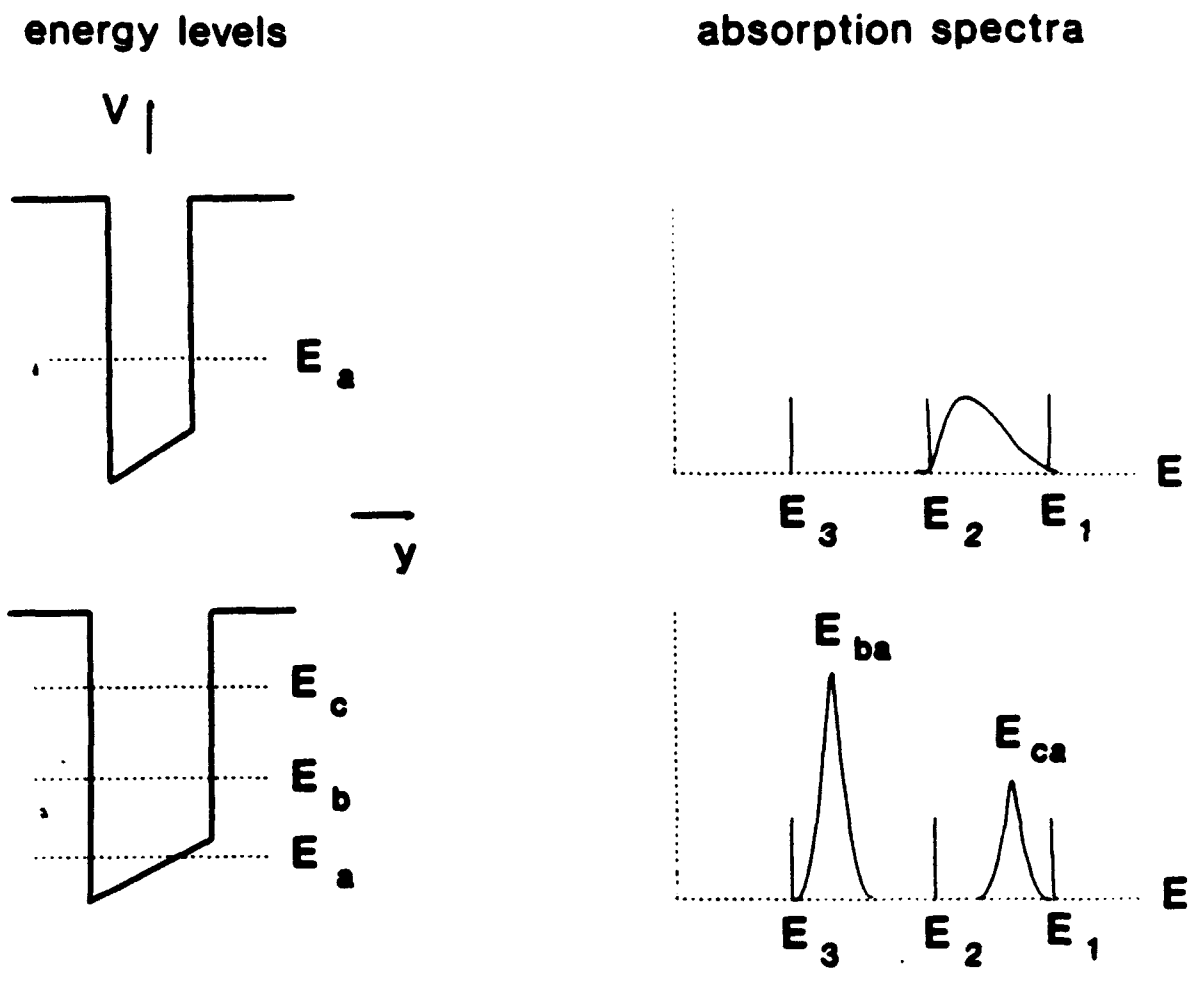

Fig. 4. Two possible well designs for DFM or SFM. The corresponding absorption spectra and laser frequencies are also shown. For the absorption spectra, it is assumed that the carriers are initially in the ground state of the well.

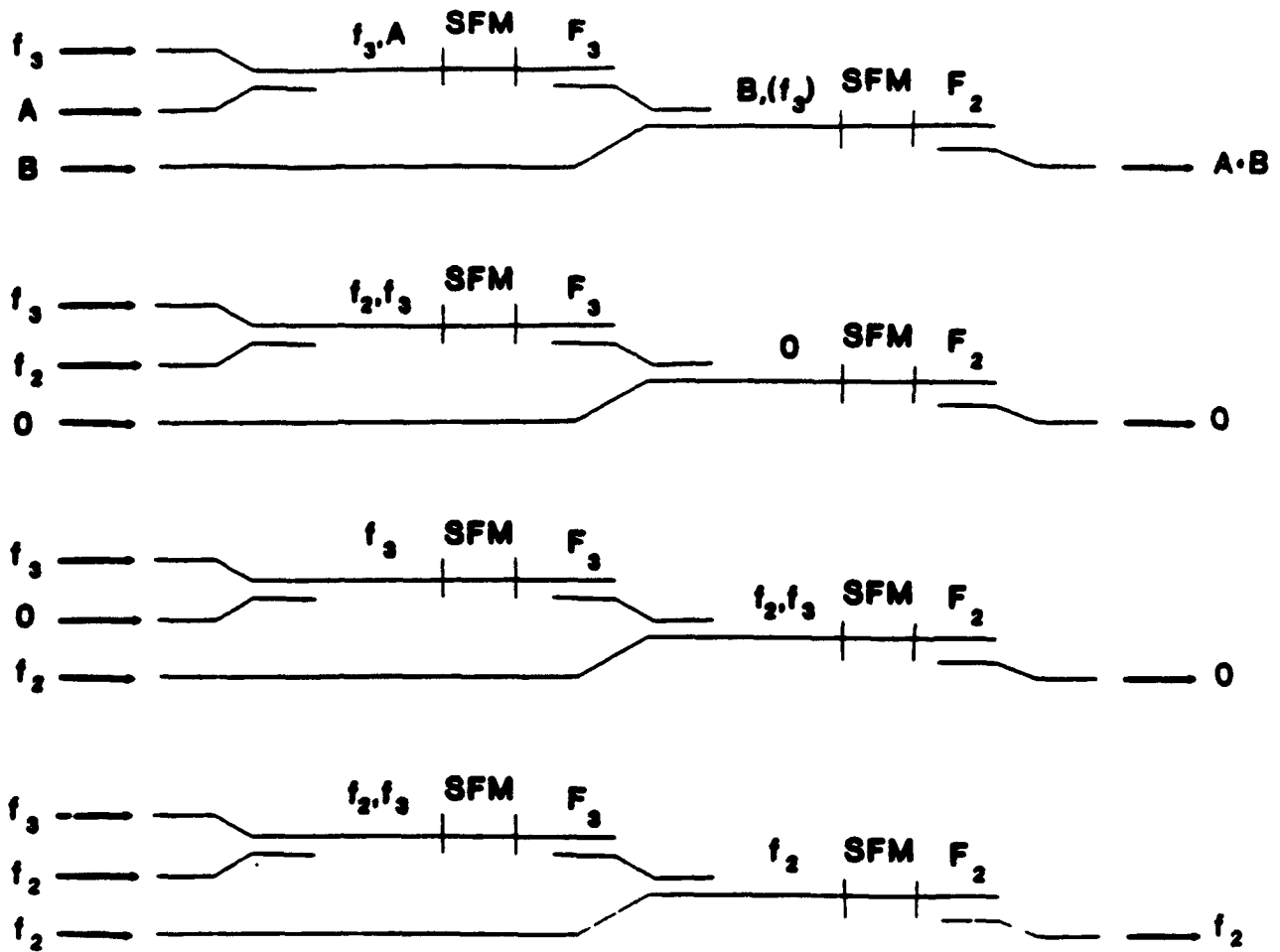

Fig. 5. AND gate using frequency mixing in channel waveguides. In the top diagram, A and B are the binary inputs and $A \cdot B$ is the output. The next three diagrams show the behavior for one or two "one" inputs; i. e., three of the four cases in the AND truth table.

show that the truth table for the AND gate is satisfied. Furthermore, logic elements of this type can be cascaded to perform more complex digital operations. Another interesting possibility is the use of frequency mixing to perform addition and subtraction, as in Fig. 6. In this case, two DFM and one SFM waveguide sections are used. The addends are encoded as frequencies relative to f_2 , as is the resultant sum. A network of Mach-Zehnder interferometers could convert the frequency-encoded optical output from the device of Fig. 6 into a parallel, binary representation of the sum.

Technical Objective

The objective of this research is to investigate the design, fabrication, and communication network application of frequency mixing devices in nonlinear optical waveguide materials. We are interested in designing novel frequency mixing devices in multi-quantum well (MQW) semiconductor materials which can provide unprecedented nonlinear conversion efficiencies. Optical wavelengths of interest are those in the near-infrared spectral regimes commonly used for optical fiber communication. Ultimately, we hope to design practical networks with as many as 5000 nodes which can support multigigabit-per-second channel data rates and have reconfiguration times as short as a few nanoseconds.

Device Design

In the design area, we have perfected a theoretical model for calculating nonlinear coefficients and dispersion characteristics of asymmetric quantum wells, and have applied it in a novel design for a frequency conversion device. The design procedure comprises the following steps:

(1) Numerical solution to Schrodinger's equation for arbitrary one-dimensional quantum wells

A computer model which uses a difference-equation technique to obtain numerical solutions to Schrodinger's equation in the effective mass approximation has been developed. The model computes energy levels and wave functions for energy eigenstates of one-dimensional quantum wells. We believe the model to be unique in that it considers bound-continuum as well as bound-bound transitions, and can be applied in cases where the carrier effective mass as well as the potential are functions of position in the well. During the course of the work, a new result which extends the Thomas Kuhn sum rule to cases in which the effective mass is a function of position was derived.

(2) Calculation of second-order nonlinear susceptibility

The expression for the second-order nonlinear susceptibility is obtained using the density matrix formalism in the dipole approximation. The expression contains the sum of a large number of terms, but can be simplified by retaining only the near-resonant terms for which one of the laser frequencies is near an absorption resonance of the quantum well. The matrix elements used in

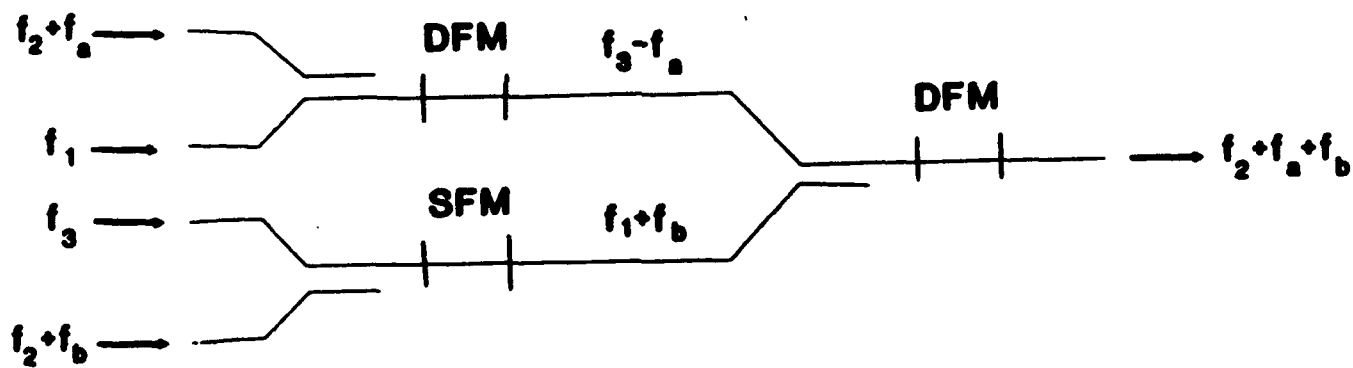

Fig. 6. SDP adder circuit.

these calculations are determined by numerical integration from the bound and continuum state wave functions obtained in step 1.

(3) Optimization of second-order susceptibility

It is desirable that the magnitude of the nonlinear coefficient be as large as possible. There are two aspects to this. One is to maximize the product of the relevant dipole matrix elements and the other is to achieve the near resonance condition. To this end, QW structures with various asymmetrical potential profiles including graded-gap and step wells have been studied. These profiles are compatible with present fabrication technology. The QWs must be asymmetrical for the nonlinear coefficient to be non-zero. This is equivalent to the requirement that a bulk nonlinear crystal lack a center of inversion symmetry.

Both bound-to-bound and bound-to-continuum transitions are considered in calculating the nonlinear coefficients. Numerical calculations indicate that the step well gives a considerably larger nonlinear coefficient than the graded well. Example of wave functions and energy levels for the two cases are illustrated in Fig. 7.

(4) Intersubband absorption calculation

Intersubband absorption involves dipole transitions between an occupied state (generally, the ground state) and an unoccupied state of the quantum well. To enhance the nonlinear coefficient, it is necessary to achieve the near-resonance condition. This results in strong absorption at the frequency for which energy states are resonant, particularly for bound-to-bound transitions. Strong intersubband absorption at any of three laser frequencies is undesirable as it diminishes the nonlinear optical effect. To reduce this strong absorption between the bound states it is necessary to adjust the well parameters such that the energy levels of the well are off-resonance by an energy substantially greater than the half-width of the absorption line. This reduction in absorption is achieved at the cost of a reduction in the magnitude of the nonlinear optical susceptibility. Thus, there is a tradeoff between achieving a large nonlinear coefficient and reducing the intersubband absorption at the laser wavelength.

(5) Dispersion

For efficient frequency conversion, it is important that the phase matching condition be satisfied. This condition can be written as $\delta = 0$, with δ a phase mismatch parameter given by

$$\delta = n_{1e} f_1 - (n_{2e} f_2 + n_{3e} f_3), \quad (1)$$

where n_{ie} is the effective refractive index of the waveguide mode at the frequency f_i , $i = 1, 2, 3$. This condition is difficult to satisfy due to dispersion effects attributable to the bulk material properties, the effect of the QWs, and the effect of a waveguide structure in which the QWs are fabricated. QW dispersion is evaluated using the Kramers-Kronig transformation, which relates the change in the refractive index due to the intersubband transition to the absorption coefficient.

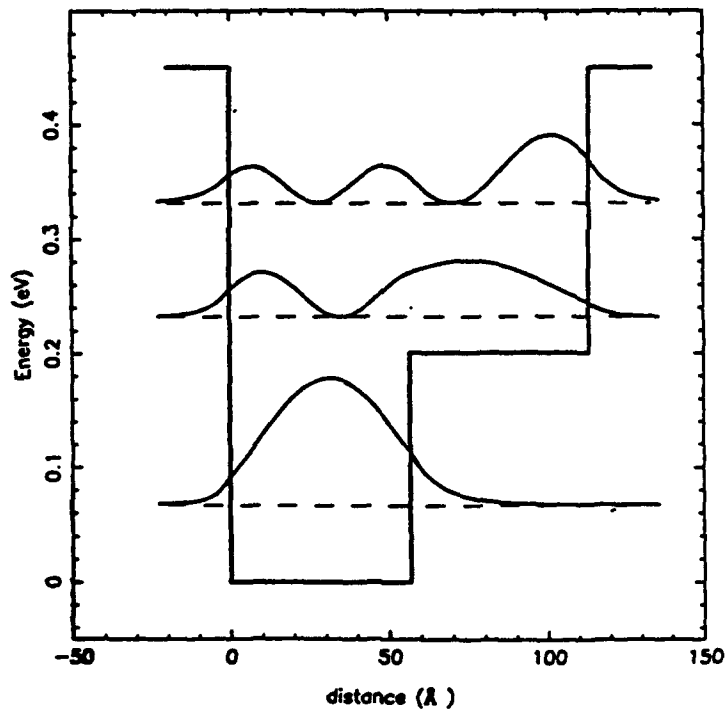
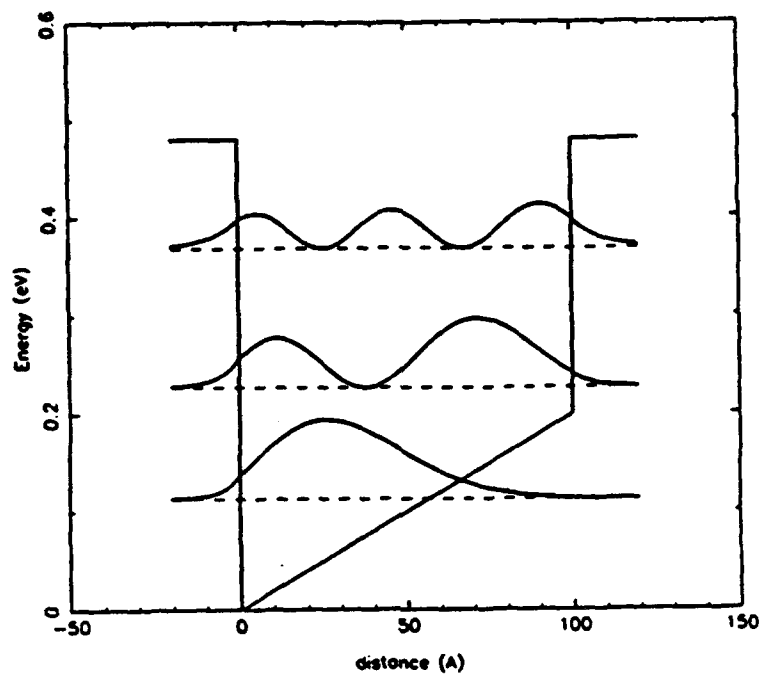

Fig. 7. Asymmetric quantum well designs with corresponding bound-state wave functions and energy levels.

Calculations show that for cases of interest it is generally not possible to achieve phase matching in an MQW structure which is uniform in the direction of propagation. The bulk dispersion term results in a monotonically decreasing refractive index, the effect of which is generally much too large to be overcome by QW and waveguide dispersion. However, we believe that quasi-phase-matching (QPM) in which the nonlinear coefficient is a periodic function of position along the propagation direction can be achieved in these materials. In designing a QPM device, a characteristic beat length L_b based upon the combined effects of bulk, QW, and waveguide dispersion is determined from the expression $L_b = c/\delta$, with c the free-space speed of light and δ the phase mismatch parameter from eq. 1. This beat length is incorporated into the design as the spatial period for the nonlinear coefficient variation.

A new approach to QPM in a nonlinear frequency converter based upon Zn diffusion in AlGaAs MQW material is proposed. The diffusion is known to cause a homogenization of the heterostructure layers, thus quenching the nonlinear interaction. By diffusing the Zn through a spatially periodic mask, phase matching can be achieved over a long interaction distance without adversely affecting optical propagation in the waveguide. A device based upon this concept is illustrated schematically in Fig. 8.

(6) Design of nonlinear MQW frequency converter

A model which calculates energy levels, wave functions, dipole matrix elements, second order nonlinear susceptibility, absorption spectra, and dispersion characteristics in QWs has been developed. This model has been applied to the design of nonlinear frequency conversion devices in asymmetric QW structures. To optimize the performance, the effect on conversion efficiency of well height, well width, and the degree of asymmetry has been studied for wells with graded and step asymmetries in the potential.

Numerical results have been obtained for the specific case that photon energies are $E_a = 0.9545$ eV ($\lambda = 1.3 \mu\text{m}$), $E_b = 0.8005$ eV ($\lambda = 1.55 \mu\text{m}$), and $E_c = 0.154$ eV ($\lambda = 8.05 \mu\text{m}$). The material system is AlGaAs, with AlAs in the barrier region, for a maximum well depth for electrons of 0.96 eV. The results indicate that the step asymmetry is preferable to the graded asymmetry. Optimized well parameters are: well width = 100 Angstroms, step height = 0.185 eV ($\text{Al}_{0.25}\text{Ga}_{0.75}\text{As}$ in the step region), step width 44 Angstroms. This well design is shown in Fig. 9. The quantum well energy levels for these parameters are $E_1 = 0.098$ eV, $E_2 = 0.264$ eV, $E_3 = 0.416$ eV. The calculated nonlinear coefficient for $10^{18}/\text{cm}^3$ electrons in the well, and a power density of $10^6 \text{ W}/\text{cm}^2$ at the laser energy E_a is calculated to be $\chi_2 = 10^{-9} \text{ m/V}$. This gives a conversion length with quasi-phase-matching of 0.6 mm for the nonlinear interaction in which laser light at input wavelengths of 1.3 μm 1.55 μm combine to produce an output at 8.05 μm . A waveguide nonlinear device based upon this MQW design is shown in Fig. 10.

Device Fabrication

To fabricate the devices we are designing, sophisticated MQW materials will be needed. To this end, we have enlisted the cooperation of Dr. William Thies of the Naval Weapons Center of China Lake, CA. Dr. Thies has recently grown several n-doped MQW samples in AlGaAs with well

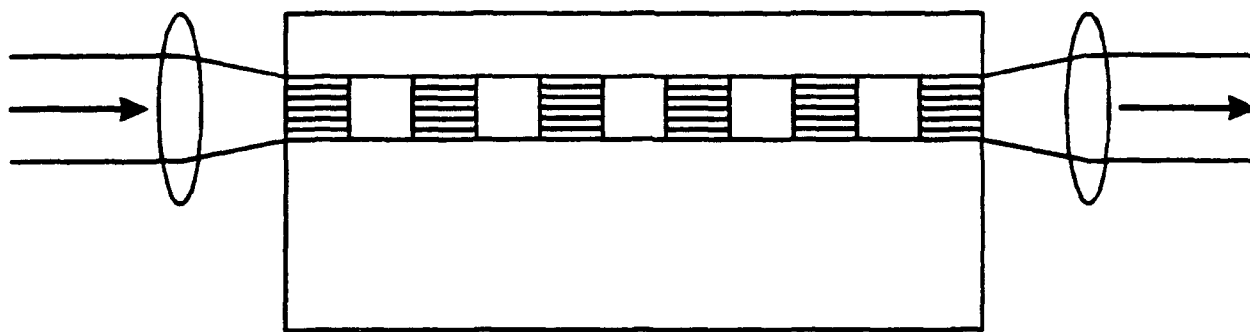

Fig. 8. Concept of quasi-phase-matching in an MQW device with a spatially periodic nonlinearity.

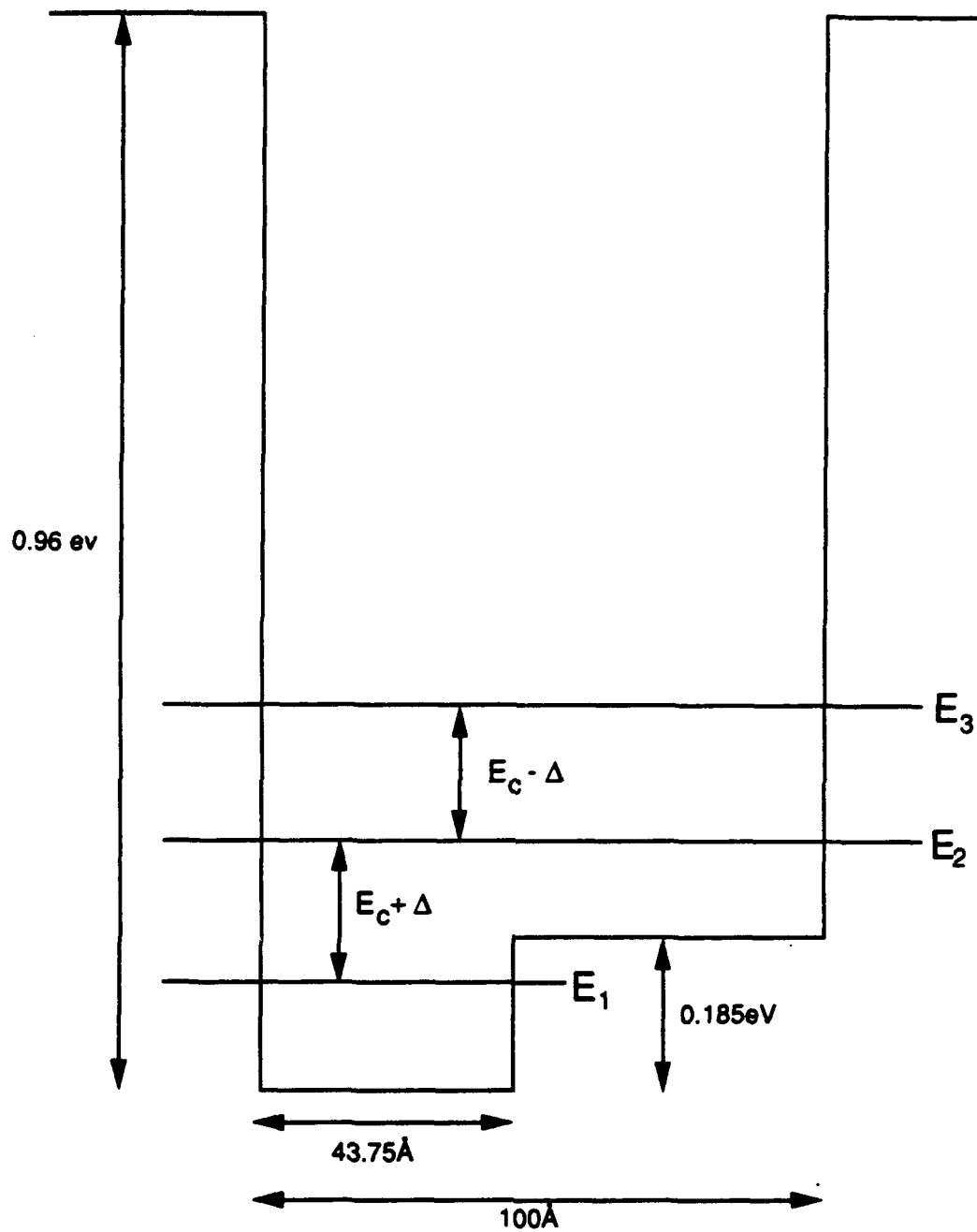

Fig. 9. Design of quantum well for difference frequency mixing at pump wavelengths near 1.3 μm and 1.55 μm .

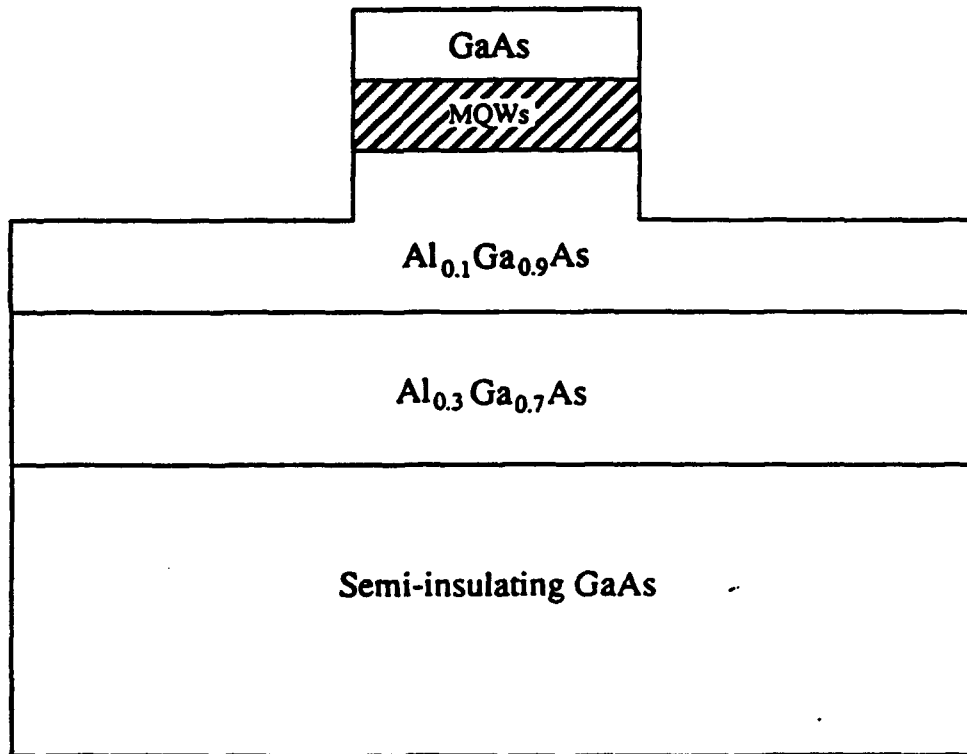

Fig. 10. Proposed structure for nonlinear frequency mixing device in an optical waveguide.

widths in the 50-80 Angstrom range in an MBE system. Evaluation of these samples by Drs. Dave Donnelly and Bill Covington of Sam Houston State University in Huntsville, TX, has shown strong intersubband absorption peaks in some of these samples, indicating that they are of the quality needed for the nonlinear device. Using our design model, we are preparing quantum well device specifications for Dr. Thies to use in his next series of growth runs. Quasi-phase-matched frequency conversion devices will then be fabricated at Texas A&M in these materials supplied by NWC.

Network Application

In many distributed computing systems, latency time as determined by the network bandwidth is a key factor in determining system performance. With the continued rapid growth in the speed and number of individual processors in state-of-the-art systems, this communication bottleneck will become even more important in the years ahead. During the next decade, LANs and WANs with thousands of processors capable of gigabit input/output rates will be developed. Fiber optic networks which effectively utilize the bandwidth of the medium will be needed for effective utilization of the enormous computing power offered by these system. Public-access networks will also grow very rapidly during the next decade, as video-bandwidth fiber optic subscriber loops begin to replace our current telephone system.

It seems likely that wavelength division multiplexing (WDM) will play a major part in the solution to the communications bottleneck, but only after formidable technical problems are overcome. WDM has for several years been one of the most vigorously pursued research topics in the optical communications field. Parallel transmission of channels using multiple wavelength carriers is well established as a cost-effective way to increase the capacity of existing or contemplated fiber installations [1]. However, commercialization of WDM is still at an early stage relative to its potential, and inexpensive components with the performance needed for future data highways are yet to be realized.

Spectral domain processing using nonlinear frequency conversion can play a role in WDM systems of the future, as it provides a way to rapidly switch the carrier frequency of a data stream. We have developed a new network concept which makes use of a nonlinear frequency conversion device to obtain rapid switching between channels in a WDM system. The network is structured as an N-dimensional hypercube connected with single mode optical fibers. Each node has N input and N output fiber lines. Transmission of data packets between nodes in a particular dimension of the hypercube is accomplished using tunable lasers. Each wavelength corresponds to a particular node in that dimension of the hypercube. The laser transmitter is adjusted to the frequency assigned to the desired cross node, at which a fixed frequency selective coupler removes the carrier. Header bits from the packet are read to determine the destination in the new hypercube dimension. Two tunable near-infrared lasers are combined in a nonlinear device, and the resultant mid-infrared output is mixed with the carrier for the data packet to switch to the carrier frequency corresponding to the destination node in the new dimension. This process continues until the data reaches its destination.

An example of a two-dimensional network of this type with $N = 2$ is illustrated in Fig. 11. A data packet is injected into the network at a wavelength near $1.55 \mu\text{m}$ from the source node; say, node T-41. The frequency of the source node tunable laser is adjusted to correspond to the frequency assigned to the destination node, say node T-21. The carrier is removed from the fiber bus by a frequency-selective coupler at node T-21. Header bits read at that node indicate that the final destination is node T-23. CW light from tunable lasers near $1.3 \mu\text{m}$ and $1.55 \mu\text{m}$ are mixed in the nonlinear device to produce a difference-frequency output near $8.05 \mu\text{m}$. This cw light is combined with the data packet carrier near $1.55 \mu\text{m}$ to produce a sum frequency corresponding to the frequency near $1.3 \mu\text{m}$ assigned to the destination node T-23. A frequency-selective coupler at that terminal removes the packet from the bus. The node terminal design is illustrated in Fig. 12.

In this network, the data does not undergo any optical-to-electrical or electrical-to-optical conversion between source and destination. The use of a multi-dimensional architecture reduces the latency time due to propagation delay between nodes by a factor of $Nm^{-(1-1/N)}$ as compared with a one-dimensional linear bus, with m the number of nodes. For example, for a $10 \times 10 \times 10$ hypercube with $m = 1000$ and $N = 3$, the latency time is reduced to 3% of that for a 1000-terminal linear bus.

We have developed another new network concept which makes use of the frequency conversion device to obtain rapid switching between channels in a wavelength-division-multiplexed system. The system is intended to make efficient use of the 20-50 GHz of bandwidth available in a single fiber in a particular wavelength regime (e. g., the $1.55 \mu\text{m}$ regime). The destination of a data packet is determined by the carrier frequency injected into the network at the source terminal. The nonlinear device makes it possible to tune to any frequency in the entire wavelength regime in a few nanoseconds. This rapid tunability, together with the fact that no processing of the packets is needed at the nodes, provides for low latency time in the network. Further latency reduction as well as improvement in the optical power budget are achieved by multidimensional connectivity.

Conclusions

A computer model for the design of nonlinear devices for frequency mixing in multiquantum well (MQW) materials has been developed. The model has been used to calculate nonlinear coefficients for mixing of pump lasers at wavelengths near $1.3 \mu\text{m}$ and $1.55 \mu\text{m}$ to produce an output near $8.05 \mu\text{m}$. A device length for conversion of 0.6 mm is predicted for a pump power density of 10^6 W/cm^2 . A quasi-phase-matching scheme for obtaining high conversion efficiency in a dispersive semiconductor material is proposed. Preliminary work on growth of MQW materials for the nonlinear device has been carried out at the Naval Weapons Center.

An N -dimensional hypercube network configuration making use of the frequency conversion devices has been proposed. The scheme allows for all-optical transmission of data from source node to destination node.

Research is continuing on optimization of device design and the investigation of network architectures based upon nonlinear frequency conversion.

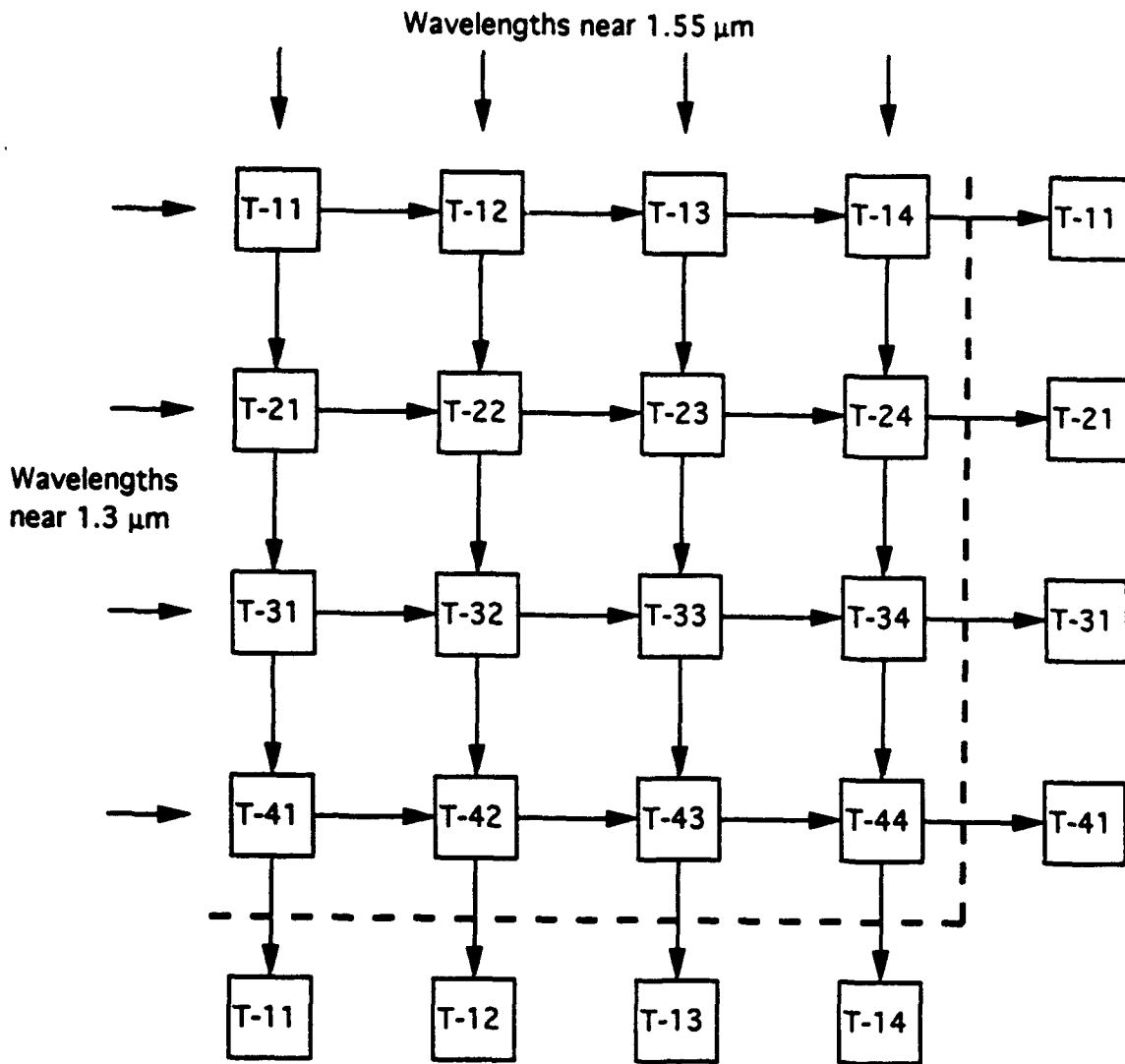

Fig. 11. Two-dimensional network configuration.

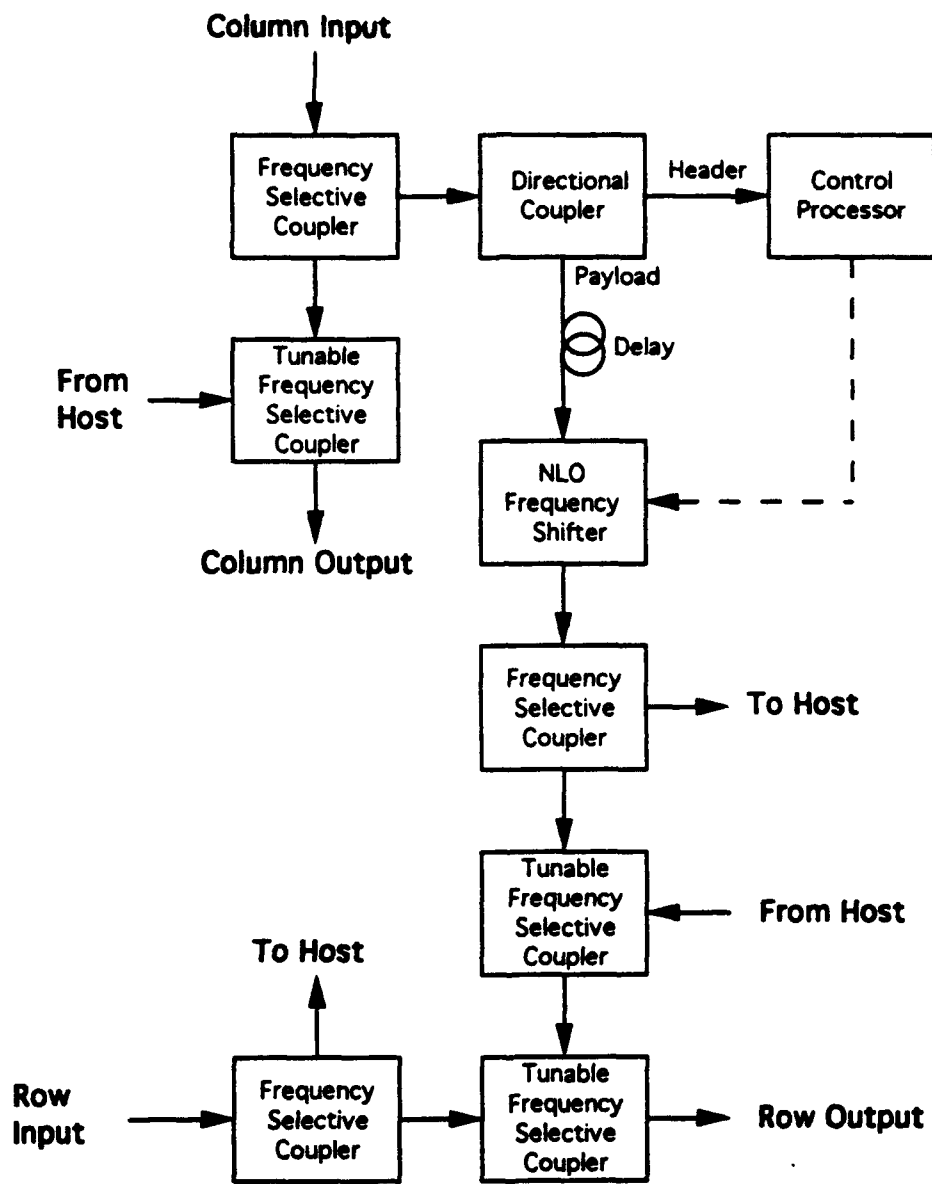

Fig. 12. Design of terminal for two-dimensional network using frequency mixing.

References:

1. M. K. Gurnick and T. A. DeTemple, "Synthetic nonlinear semiconductors," *IEEE J. Quant. Electron.*, vol. 19, pp. 791-794, May 1983.
2. E. Rosencher, P. Bois, J. Nagle, and S. Delaitre, "Second harmonic generation by intersubband transitions in compositionally asymmetrical MQWs," *Electron. Lett.*, vol. 25, pp. 1063-1065, Aug. 3, 1989.
3. M. M. Fejer, S. J. B. Yoo, R. L. Byer, A. Harwit, and J. S. Harris, "Observation of extremely large quadratic susceptibility at 9.6-10.8 μm in electric-field-biased AlGaAs quantum wells," *Phys. Rev. Lett.*, vol. 62, pp. 1041-1044, Feb. 1989.
4. D. A. Holm and H. F. Taylor, "Infrared phase modulators with multiple quantum wells," *IEEE J. Quant. Electron.*, vol. 25, pp. 2266-2271, Nov. 1989.
5. J. D. Wiley, "Mobility of holes in III-V compounds," in *Semiconductors and Semimetals*, vol. 10 (ed. by Willardson and Beer, p. 101).
6. C. M. Wolfe, N. Holonyak, and G. E. Stillman, *Physical properties of semiconductors*, (Prentice Hall, Englewood Cliffs, N. J., 1989), p. 340.

Approved for public release;
distribution unlimited.

AIR FORCE OF SCIENTIFIC RESEARCH (AFSC)
NOTICE OF TRANSMITTAL TO DTIC

This technical report has been reviewed and is
approved for public release IAW AFR 190-12
Distribution in unlimited.

Joan Boggs
STINFO Program Manager