

Technical Report  
CMU/SEI-94-TR-007  
ESC-TR-94-007

2



Carnegie Mellon University  
Software Engineering Institute

AD-A278 719



DTIC  
ELECTE  
SUMMER 1994  
S B D

# A Practical Guide to the Technology and Adoption of Software Process Automation

Alan M. Christie

March 1994

**DISTRIBUTION STATEMENT 4**  
Approved for public release  
Distribution Unlimited

DTIC QUALITY INSPECTED 3

94-12923



1/19/95

94 4 28 032

Technical Report  
CMU/SEI-94-TR-007  
ESC-TR-94-007  
March 1994

# A Practical Guide to the Technology and Adoption of Software Process Automation



**Alan M. Christie**

CASE Environments Project

DTIC QUALITY INSPECTED 3

Approved for public release.  
Distribution unlimited.

**Software Engineering Institute**  
Carnegie Mellon University  
Pittsburgh, Pennsylvania 15213

This technical report was prepared for the

SEI Joint Program Office  
ESC/ENS  
Hanscom AFB, MA 01731-2116

The ideas and findings in this report should not be construed as an official DoD position. It is published in the interest of scientific and technical information exchange.

#### Review and Approval

This report has been reviewed and is approved for publication.

FOR THE COMMANDER



Thomas R. Miller, Lt Col, USAF  
SEI Joint Program Office

The Software Engineering Institute is sponsored by the U.S. Department of Defense.  
This report was funded by the U.S. Department of Defense.

Copyright © 1994 by Carnegie Mellon University.

Copies of this document are available from Research Access, Inc., 800 Vinal Street, Pittsburgh, PA 15212. Telephone: (412) 321-2992 or 1-800-685-6510, Fax: (412) 321-2994.

This document is available through the Defense Technical Information Center. DTIC provides access to and transfer of scientific and technical information for DoD personnel, DoD contractors and potential contractors, and other U.S. Government agency personnel and their contractors. To obtain a copy, please contact DTIC directly: Defense Technical Information Center, Attn: FDRA, Cameron Station, Alexandria, VA 22304-6145.

Copies of this document are also available through the National Technical Information Service. For information on ordering, please contact NTIS directly: National Technical Information Service, U.S. Department of Commerce, Springfield, VA 22161.

Use of any trademarks in this report is not intended in any way to infringe on the rights of the trademark holder.

# Table of Contents

<b>1</b>	<b>Introduction</b>	<b>1</b>
<b>2</b>	<b>Software Process Automation in Context</b>	<b>5</b>
2.1	Process Automation and Related Technologies	5
2.2	Issues Related to CASE and Process Improvement	6
2.3	Why Use a Process-Centered Framework?	12
2.3.1	Advantages of Using a PCF	12
2.3.2	Disadvantages of Using a PCF	13
<b>3</b>	<b>An Experimental Investigation into PCFs</b>	<b>15</b>
3.1	The Experimental Approach	15
3.2	Model-Building Capabilities (Phase 1)	17
3.3	End-User Capabilities (Phase 2)	20
3.4	Process Example and Its Execution Script (Phase 3)	20
3.5	Evaluation Criteria and Questionnaire (Phase 4)	25
<b>4</b>	<b>The ProcessWeaver Experiment</b>	<b>27</b>
4.1	Review of ProcessWeaver	27
4.1.1	Agenda Window	27
4.1.2	Work Context Window	28
4.1.3	Method Editor	29
4.1.4	Activity Editor	30
4.1.5	Cooperative Procedure Editor	30
4.1.6	Pulling the Elements Together	34
4.2	Developing the ProcessWeaver Process Model	36
4.3	The Evaluation	39
4.3.1	Functionality	39
4.3.2	Developer Issues	44
4.3.3	End-User Issues	45
4.3.4	Performance	46
4.3.5	System Interface	46
4.3.6	Off-line User Support	47
4.4	Improvements in Functionality	48
<b>5</b>	<b>The Synervision Experiment</b>	<b>49</b>
5.1	Review of SynerVision	49

5.1.1	Managing Personal Tasks	50
5.1.2	Managing Group Tasks	52
5.1.3	Process Enactment Through the Use of Templates	52
5.1.4	Process-Centered Environments	54
5.2	Developing the Synervision Process Model	55
5.3	The Evaluation	55
5.3.1	Functionality	57
5.3.2	Developer Issues	60
5.3.3	End-User Issues	62
5.3.4	Performance	63
5.3.5	System Interface	63
5.3.6	Off-Line User Support	64
<b>6</b>	<b>End-User Role Plays</b>	<b>65</b>
6.1	User Interface	65
6.2	Adoption Issues	69
6.3	Application Issues	70
<b>7</b>	<b>A Comparison of ProcessWeaver and Synervision</b>	<b>73</b>
<b>8</b>	<b>Adopting and Using Process Automation Technology</b>	<b>79</b>
8.1	Process Automation and Process Maturity	79
8.2	Guidelines for Adopting Automated Process	79
8.3	Transitioning to a PCF	82
<b>9</b>	<b>Summary and Conclusions</b>	<b>87</b>
	<b>References</b>	<b>91</b>
	<b>Appendix A Vendor Information on PCFs</b>	<b>95</b>
	<b>Appendix B Listing of SynerVision Experiment Script</b>	<b>97</b>
	<b>Appendix C A Brief Overview of ProNet</b>	<b>103</b>
	<b>Appendix D Terminology and Concepts</b>	<b>107</b>
	<b>Appendix E End-User Evaluation Materials</b>	<b>111</b>
	<b>Acknowledgments</b>	<b>117</b>

## List of Figures

<b>Figure 2-1:</b>	<b>The Five Levels of the Maturity Model</b>	<b>9</b>
<b>Figure 2-2:</b>	<b>Tool-Use Characteristics at the Five Maturity Levels</b>	<b>11</b>
<b>Figure 3-1:</b>	<b>Simplified Evaluation Process</b>	<b>16</b>
<b>Figure 3-2:</b>	<b>The Modify Document Process</b>	<b>21</b>
<b>Figure 3-3:</b>	<b>The Identify Agents for Roles Process</b>	<b>22</b>
<b>Figure 3-4:</b>	<b>The Update Document Process</b>	<b>23</b>
<b>Figure 3-5:</b>	<b>Sequence of Evaluation Tasks</b>	<b>26</b>
<b>Figure 4-1:</b>	<b>An Agenda Window</b>	<b>28</b>
<b>Figure 4-2:</b>	<b>A Work Context Window</b>	<b>29</b>
<b>Figure 4-3:</b>	<b>A Method Editor Window</b>	<b>30</b>
<b>Figure 4-4:</b>	<b>An Activity Editor Window</b>	<b>31</b>
<b>Figure 4-5:</b>	<b>A Cooperative Procedure Window</b>	<b>32</b>
<b>Figure 4-6:</b>	<b>Overview of ProcessWeaver Elements</b>	<b>35</b>
<b>Figure 4-7:</b>	<b>Activity Hierarchy for the Example Process</b>	<b>36</b>
<b>Figure 4-8:</b>	<b>Cooperative Procedure for the Activity Review/Identify</b>	<b>37</b>
<b>Figure 4-9:</b>	<b>Cooperative Procedure for the Activity Update</b>	<b>38</b>
<b>Figure 4-10:</b>	<b>Co-Shell Library Functions to Retrieve and Save Document Files</b>	<b>39</b>
<b>Figure 5-1:</b>	<b>SynerVision Main Window Illustrating a Task Hierarchy</b>	<b>50</b>
<b>Figure 5-2:</b>	<b>SynerVision Access Attributes Window</b>	<b>53</b>
<b>Figure 5-3:</b>	<b>SynerVision Task In-Box Window</b>	<b>53</b>
<b>Figure 5-4:</b>	<b>Dialog Window Generated Through the svprompt Command</b>	<b>54</b>
<b>Figure 5-5:</b>	<b>Example of a Short SynerVision Script</b>	<b>56</b>
<b>Figure 6-1:</b>	<b>Summary of End-User Experiences</b>	<b>66</b>
<b>Figure 6-2:</b>	<b>Summary of End-User Views on Adoption of Automated Process</b>	<b>67</b>
<b>Figure 6-3:</b>	<b>Summary of End-User Views on Appropriate Applications</b>	<b>67</b>
<b>Figure C-1:</b>	<b>Definition of Activities Associated Only with "Store" Entities</b>	<b>105</b>
<b>Figure C-2:</b>	<b>Simple ProNet Change Request Model</b>	<b>105</b>
<b>Figure D-1:</b>	<b>Relationship Between Process Enactment Concepts</b>	<b>109</b>

<b>Accession For</b>	
NTIS GRA&I	<input checked="" type="checkbox"/>
DTIC TAB	<input type="checkbox"/>
Unannounced	<input type="checkbox"/>
<b>Justification</b>	
By _____	
Distribution/ _____	
<b>Availability Codes</b>	
<b>Dist</b>	<b>Avail and/or Special</b>
A-1	



## List of Tables

<b>Table 2-1:</b>	<b>Pages of Practices at the Five CMM Levels</b>	<b>10</b>
<b>Table 3-1:</b>	<b>Model-Building Capabilities</b>	<b>18</b>
<b>Table 3-2:</b>	<b>End-User Capabilities</b>	<b>20</b>
<b>Table 3-3:</b>	<b>PCF Evaluation Areas</b>	<b>25</b>
<b>Table D-1:</b>	<b>Relationship to NIST Service Categories</b>	<b>110</b>
<b>Table E-2:</b>	<b>Process Enactment Scenario</b>	<b>112</b>
<b>Table E-3:</b>	<b>Questionnaire for End-User Role Plays</b>	<b>113</b>



# A Practical Guide to the Technology and Adoption of Software Process Automation

**Abstract:** Process automation provides a means to integrate people in a software development organization with the development process and the tools supporting that development. For many reasons, this new technology has the potential to significantly improve software quality and software development productivity. As yet, however, there is little practical experience in its day-to-day use. The main goal of this report is thus to provide information for organizations that are considering its adoption. For these reasons, the report aims to identify how process automation relates to both process improvement and CASE tools, to review in some detail two of the major commercial process automation products, and to address relevant organizational adoption issues. It is hoped that the report will help bridge the gap between those whose focus is software process improvement and those whose focus is software technology.

## 1 Introduction

Consider two scenarios:

*Jim is the manager responsible for developing the software performance requirements on a flight control computer. Since he is, as usual, overloaded, he asks Bob, one of his engineers, to determine the timing constraints on the system. Bob, who is new to the job, performs the task but significantly overestimates the values. He e-mails these to Jim who inserts them into the requirements document. At the requirements review, Mary who is familiar with timing constraints realizes that something is wrong and requests a recalculation. Jim readily agrees, but because he is preoccupied, forgets to inform Bob about the problem, and corrective action is never taken. When the system is built, a major crisis develops when it is found that the control computer cannot perform the job...*

*The Nala Corporation has decided that, in order to compete for Government contracts, it must improve its software development process. It has taken to heart the belief that you cannot understand what you do not measure, and it therefore initiates a major metrics program. The program's primary focus is to measure programmer productivity and task schedules. To perform this collection task, upper management requests that developers and project managers fill out an electronic form each week identifying task status and lines of code written. Unfortunately, the perception within the ranks is that this is an intrusive bureaucratic hassle that does not help in supporting the on-going projects, many of which are behind schedule and in need of every man-hour they can get. Thus the forms are resented, only sometimes filled in, and when they are, many errors are made. The result is that no meaningful improvements are made on the basis of the results...*

These scenarios represent two fictitious, but realistic, examples of how ineffective processes can put an organization in jeopardy. A well-defined and implemented process will go a long way to resolving these problems, but manual implementation of this process can, in the short run, be time consuming even if, in the long run, it is beneficial. In a competitive commercial environment there is therefore an enormous temptation to skip anything that gets in the way of developing the final product. In the manufacture of mechanical and electrical products, process automation has made dramatic impacts in improving productivity; there is no reason why similar approaches cannot work with software. Process automation represents a technology that can help manage this problem by:

- guiding sequences of activities that compose the project,
- managing the products that are being developed,
- invoking tools that developers require to do their tasks,
- performing automatic actions that do not need human intervention,
- allowing communication between the persons who are building the product,
- gathering metric data automatically,
- supporting personal task management,
- reducing human errors, and
- providing project management with current, accurate status information.

However, there are also pitfalls and these, along with the advantages, will be discussed in Section 2.3.3.

Because of the potential impact of process automation, it is important to assess it objectively and to understand both the technical and organizational issues. This is the main motivation behind this report, which is intended to provide practical guidance on process automation technology and its adoption. The report will look into three aspects of the automated process. First the report will look at the automated process's relationship to software process and CASE tools; second, it will investigate in some depth the characteristics of two commercially-available process automation products; and third, it will address the issues in adopting process automation into a software development organization.

Because process automation requires that a project works within a well-defined process, a clear understanding of one's operating procedures is an important prerequisite. Indeed to be most effective, process automation must be viewed within the context of process improvement. This is so since experience gained in working within the process should be incorporated into the process program to make it more effective. Process automation products are qualitatively different from standard CASE tools since the latter do not significantly affect organizational behavior. (CM tools are the exception, but they emphasize data management rather than process management.) Thus Section 2 of this report discusses the relationship of process automation to process improvement and in particular the SEI Capability Maturity Model [Paulk 93]. This discussion also addresses CASE tools and how they fit within this context.

The major part of the report then focuses on assessing the current technology by selecting and analyzing two of the foremost process automation products in the field: ProcessWeaver from Cap Gemini and SynerVision from Hewlett-Packard. In performing this analysis, it is necessary to explore these products in some depth; otherwise, a superficial impression may result in erroneous conclusions. This assessment is conducted by using a technique that was designed to consistently evaluate environments [Weiderman 86]. A standard process model is first established. The model is then implemented in each product, and each product is then measured against a set of evaluation criteria. This investigation is aimed at assessing the technology by looking at specific examples of commercial products; it is not designed to rank the products. As it turns out both of these products excel in some ways and are weak in others.

The final issue to be addressed in the report is adoption. To date there are few, if any, examples of process automation technology being used to support software development on a day-to-day basis. Thus there is little hard evidence of the efficacy of such technology. However, experience gained through process improvement, adopting technology in general, and CASE tools in particular sheds some light on the issues.

Appendix A provides information on specific commercial products, and what platforms they operate on, while Appendix B lists the process program for the SynerVision experiment. Appendix C provides a brief overview of the ProNet process definition notation as this notation is used to define the evaluation models, while Appendix D briefly reviews some of the process-related terminology used in this report. A brief note on this terminology is needed here. A process automation product may fall into the category of either a process-centered environment (PCE) or a process-centered framework (PCF) depending on whether or not the product includes end-user applications. The relationship between PCEs and PCFs and other process concepts is discussed and clarified in Appendix D. For simplicity, when we are later discussing the products under review, we will use the term PCF for either, unless there is a need to differentiate between a PCE and a PCF. Finally, Appendix E lists the scenario script and questionnaire given to the participants of the SynerVision and ProcessWeaver role plays.



## 2 Software Process Automation in Context

Over the last two hundred years, traditional manufacturing processes have seen two major revolutions. First, manufacturing, which started out as a craft industry, evolved to mass production. Second, in the past few decades, significant advances have been made in what has been called "lean" production, as exemplified by many of the Japanese automobile manufacturers [Womack 90]. This last revolution is still in progress and has led to major improvements both in productivity and quality. The history of software manufacturing is much shorter, spanning decades rather than centuries, but software production still uses techniques that have much in common with craft industries. In craft industries, products of high quality and sophistication can be produced, but such products rely heavily on skilled experts. Given the phenomenal growth of the software industry, relying on the limited supply of these experts has been a major contributor to what has been called the software crisis. Thus there is a need for techniques that can leverage the skills of software engineers, simultaneously improving productivity and quality. Given the precedent of traditional manufacturing, this is not an unreasonable goal.

### 2.1 Process Automation and Related Technologies

Research into the technology of software process modeling and automation has been ongoing for some years [Derniame 92, Kaiser 90, Mi 92, Peuschel 92, Kellner 90a, Curtis 92], but only recently have commercial implementations come on the market. Both the research into, and subsequent commercialization of, process automation technology have resulted in a considerable body of theoretical and developmental knowledge. This knowledge includes, for example, appropriate process modeling formalisms and languages. The STARS program is an example of a significant effort that is attempting to develop and apply process-oriented technologies in support of large-scale software development within the US Department of Defense. This effort has addressed a wide variety of process-related issues, and specifically has investigated process definition, modeling, and enactment [STARS 92].

The characteristics that distinguish PCFs (and PCEs) from other software engineering environments are:

- their explicit focus on process mechanisms, and the resulting need for process definition and enactment languages; and
- their emphasis on communication between, and integration of, people and their actions, rather than on the communication between, and integration of, tools.

Agreed-to or de-facto tool integration standards are important for PCFs, if PCFs are to connect to the wider field of CASE. Within the CASE integration community, there are several developments that are helping in this direction. For example, the conventions introduced by BMS

[Brown 93a], CORBA [Soley 92], or PCTE [Brown 93a] are providing an impetus to third-party developers to be "compliant". Indeed, the two PCFs that we will be investigating have mechanisms to address tool-integration issues.

Much research and commercial work has also been done on the integration of CASE tools. On the commercial side, integration has been traditionally tool-to-tool, with limited process implications. An example of such a tool-to-tool integration is the linking of a word processor with a configuration management (CM) tool in order to manage document versions [CW]. More ambitious efforts to develop integrated tool sets have been attempted, but usually in research-oriented settings. For example in [Brown 93b] a software development scenario was constructed with Softbench as the framework and using a variety of tools for C-code development, testing, metrics collection, and configuration management. With this level of complexity, it was found that a process model, written in C, was required to manage the sequencing of events.

Many configuration management systems have also addressed practical process issues. While earlier CM products have built-in hard-wired process models [Dart 91], more recent systems have started to provide the capability for end-user process customization (e.g., CaseWare). However, the emphasis in CM systems is more (but not exclusively) on the management of product than on the management of process. PCFs and CM products are likely to have different notions of process management, and integration of PCF and CM services will be painful unless some standards are agreed to. Otherwise a PCF will only be able to call on a limited subset of the services supported by a CM tool.

In the longer term, merging of the concepts in process automation and configuration management may occur in which there is a fusing of data management and process management features. Indeed, CASE integration may benefit from such a union, since tools will then be supported by a compatible and consistent set of product and process services.

## **2.2 Issues Related to CASE and Process Improvement**

In attempting to move software development away from the craft approach (which is highly skilled and individualistic) to a more rational means of production, two approaches have been pursued:

- using technology to support, automate, and to some extent reduce the skill level required for software development; and
- improving the process through which the software is developed.

Because these two paths have a direct bearing on the technology of software process automation, they are discussed below in some detail. These paths also cross, and it is at this intersection that process-centered environments exist.

The first approach involves the use of CASE tools to help produce software more efficiently. At the developer level these tools support such activities as design, code generation, test, reverse engineering, and document production. At the management level these tools support

such activities as configuration management, planning, scheduling, tracking, and cost estimation. However, to date, CASE tools have not lived up to their early promise in the sense that a very large fraction of those purchased become "shelfware" [Page-Jones 92]. This is, in part, a consequence of the exaggerated claims of CASE tool vendors. It also results from a too narrow focus on CASE technology. As stated in [Boone 91]:

*The current attempts at CASE implementation have only been at the tactical level, dealing with such issues as tool evaluation and selection, and choosing pilot projects for applications of these tools. These tactical approaches have met with extremely limited success, and a growing number of experienced users are sharing the opinion that the situation will continue unless CASE is approached strategically.*

By strategic thinking, Boone suggests that four elements, closely related to total quality management, are required:

- pursuing continuous improvement,
- putting quality first,
- using process engineering, and
- facilitating change.

This report focuses on the last two of these items. Practical guides to addressing some of these CASE issues are provided in [Oaks 92, Fletcher 93]. In particular, these guides provide strategies for CASE adoption, addressing some of the "strategic" issues identified in [Boone 91], and have relevance to the adoption issues to be discussed in Section 8. Also, many of the issues addressed by Boone's four elements involve human factors and thus may give a degree of discomfort to many who are technically trained and naturally look for technical solutions. However, as Boone points out, the success of CASE will be just as dependent on non-technical, as on technical considerations. These non-technical issues have much in common with the spirit of the Capability Maturity Model [Paulk 93a] that provides a practical incremental approach to process improvement. Because of its relevance, the CMM will be discussed below within the context of tools and process automation.

The above issues are even more acute when dealing with integrated tool sets. To date, tool vendors have developed some direct tool-to-tool integrations (for example, IDE's integration of Software through Pictures, CodeCenter, and FrameMaker). However, successful use of integrated tools, as reflected in actual day-to-day use for product development, is quite limited. As stated in [Rader 93]:

*[I]nformal discussions with practicing software engineers from the defense and engineering communities indicate that few of the concepts, standards and products that purport to provide CASE tool integration have found their way into operational use.*

Given the problems associated with the adoption of individual CASE tools, it is perhaps not surprising that adoption of integrated CASE tool sets has met with resistance. In addition to the issues associated with the introduction of single CASE tools, integrated CASE tool sets are more expensive, magnify the process and adoption issues, and will incur significant training costs. While the above issues are also relevant to PCFs, PCFs may provide the critical ingredient, process structure, that will help CASE tools and integrated tool sets overcome some of these barriers. Some itemized reasons why this is so are given below:

- Specific elements of tool functionality can be matched to the needs of the process.
- Training in the use of the tools can be seen in the context of the process.
- Tools can be more rationally evaluated and selected.
- The process provides a framework for communication between tools.
- Metrics collection on tool-related data can be given a more rational basis.

In summary, CASE tools and integrated tool sets have failed to reach their full potential in part because of issues which are less technical and more organizational or cultural. PCEs may force some of these issues to be addressed more explicitly, and may thus be important in the successful adoption of CASE.

Let us now turn to the second approach to moving software production away from its craft origins — process improvement. A project that does not have a clear understanding of the processes through which it develops its software is likely to produce an inferior product. This is particularly so for large projects having many people and producing large, complex software systems. It was because of the consistent failure to successfully manage the development of such large software systems that the Capability Maturity Model was developed. The CMM provides a framework for establishing effective processes for software development and does so in a manner that prioritizes the implementation of the practices necessary to build effective processes.

The CMM is based on five levels, which are:

- Level 1: Initial
- Level 2: Repeatable
- Level 3: Defined
- Level 4: Managed
- Level 5: Optimizing

The general characteristics of these are summarized in Figure 2-1 [Paulk 93a]. At Level 2 (Repeatable), there is a strong focus on developing effective management practices within projects. At Level 3 (Defined), standard processes are defined across the whole organization and tailored for use within individual projects. Level 4 (Managed) then sets quantitative quality goals for both processes and products, making extensive use of metrics to achieve this objective. Finally, at Level 5 (Optimizing), the emphasis is on continuous process improvement

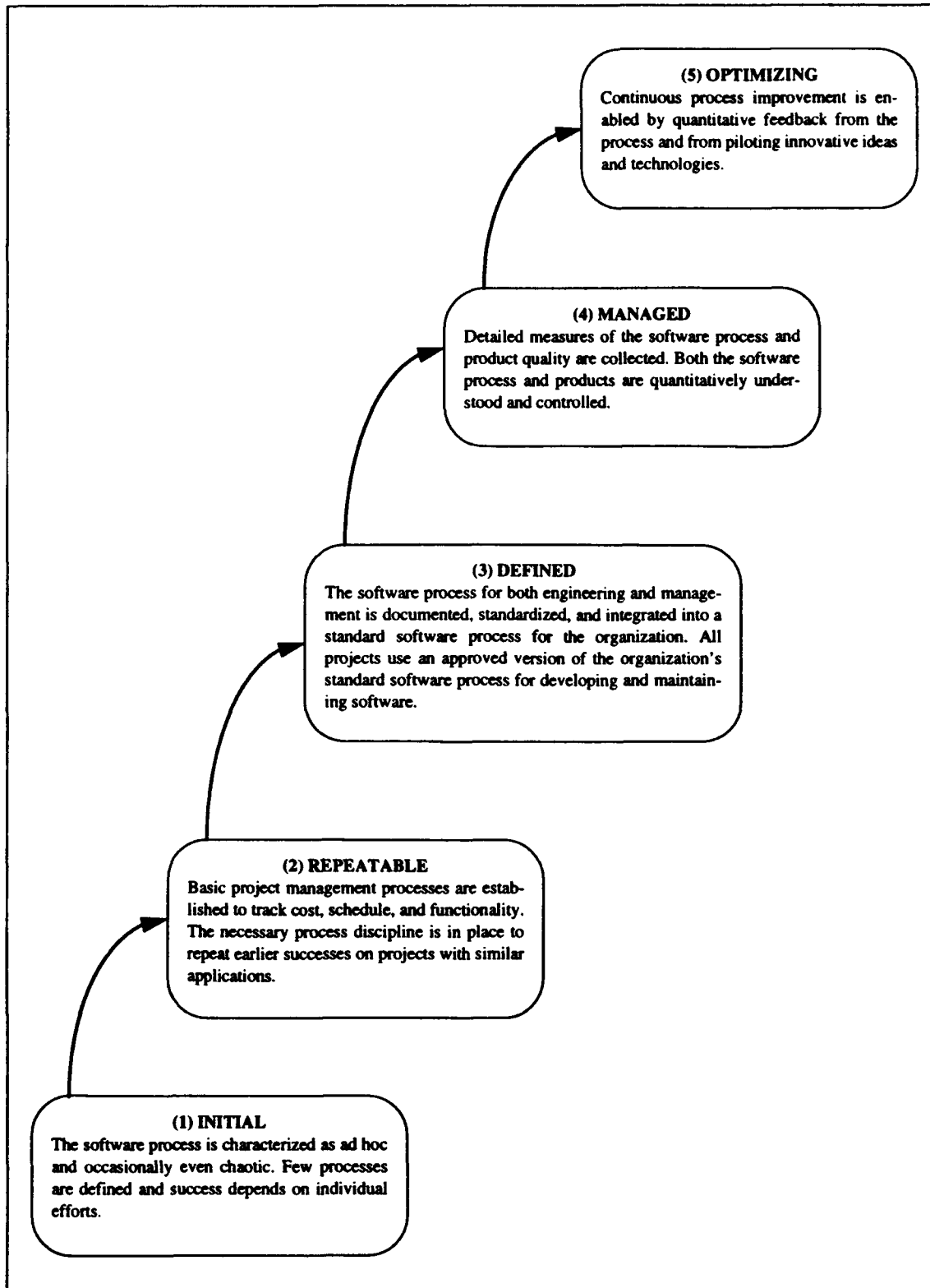

**Figure 2-1: The Five Levels of the Maturity Model**

through technology innovation and quantitative cost-benefit analysis on alternative processes. Before a particular level can be achieved by an organization, all the requirements of the lower maturity levels must be met. Each level is composed of a set of Key Process Areas (KPAs), such as Requirements Management at the Repeatable Level, while each KPA is in turn composed of a set of specific practices.

This view of process maturity is independent of tools or tool support. However, at higher levels of software maturity, there is increasing overhead associated with maintaining this maturity, as a result of the cumulative number of practices that must be supported. To get an idea of the extent of the effort required to achieve a particular maturity level, Table 2-1 shows the number of pages of practices from [Paulk 93b] that are required to characterize each maturity level. Since each page provides specific and detailed information and guidance, these simple data give an idea of the effort necessary to reach and sustain a particular level. Clearly, not all practices can be automated or even supported by software tools. However, a significant number can have at least partial support, and it has been argued [Ett 91] that "[a]utomated process enactment support is necessary to achieve a process maturity beyond SEI Level 3 in a COST EFFECTIVE manner." Given the large number of practices at and below Level 3, it is possible that automation may also be a critical component for levels 2 and 3, if cost effectiveness is important.

**Table 2-1: Pages of Practices at the Five CMM Levels**

Maturity Level	1	2	3	4	5
Pages of practices at Level	0	84	100	32	48
Cumulative pages of practices at Level	0	84	184	216	260

In many instances, there is a clear relationship between tool functionality and the needs of a particular Key Process Area. For example, the Level 2 KPA "Software Project Planning" is likely to make use of project management tools. While this relationship is important, it is more useful, in the context of this report, to correlate tool use to the broad goals of each maturity level. Figure 2-2<sup>1</sup> illustrates this other relationship. For example, at Level 2, there will be sets of guidelines on tool selection, tool use, and tool training at the project level. In addition tool use will be integrated into the project-defined processes by which the software is produced. The view of the technology/process relationship shown in Figure 2-2 is useful because it implies that one can start to use a PCF at any maturity level. However, if a PCF is used at Level 1, only limited components of its functionality can be effectively employed (for example, code development at the individual level, personal scheduling, and task routing).<sup>2</sup> At Level 2, a much

<sup>1</sup> This figure was developed by the author to be consistent with the CMM, but is not part of it.

<sup>2</sup> This is not to say that an actual Level 1 organization cannot start to define its processes and then implement some of the simpler, less critical of them through a PCF. Indeed this may be part of the activities that the Level 1 organization performs in order to achieve Level 2.

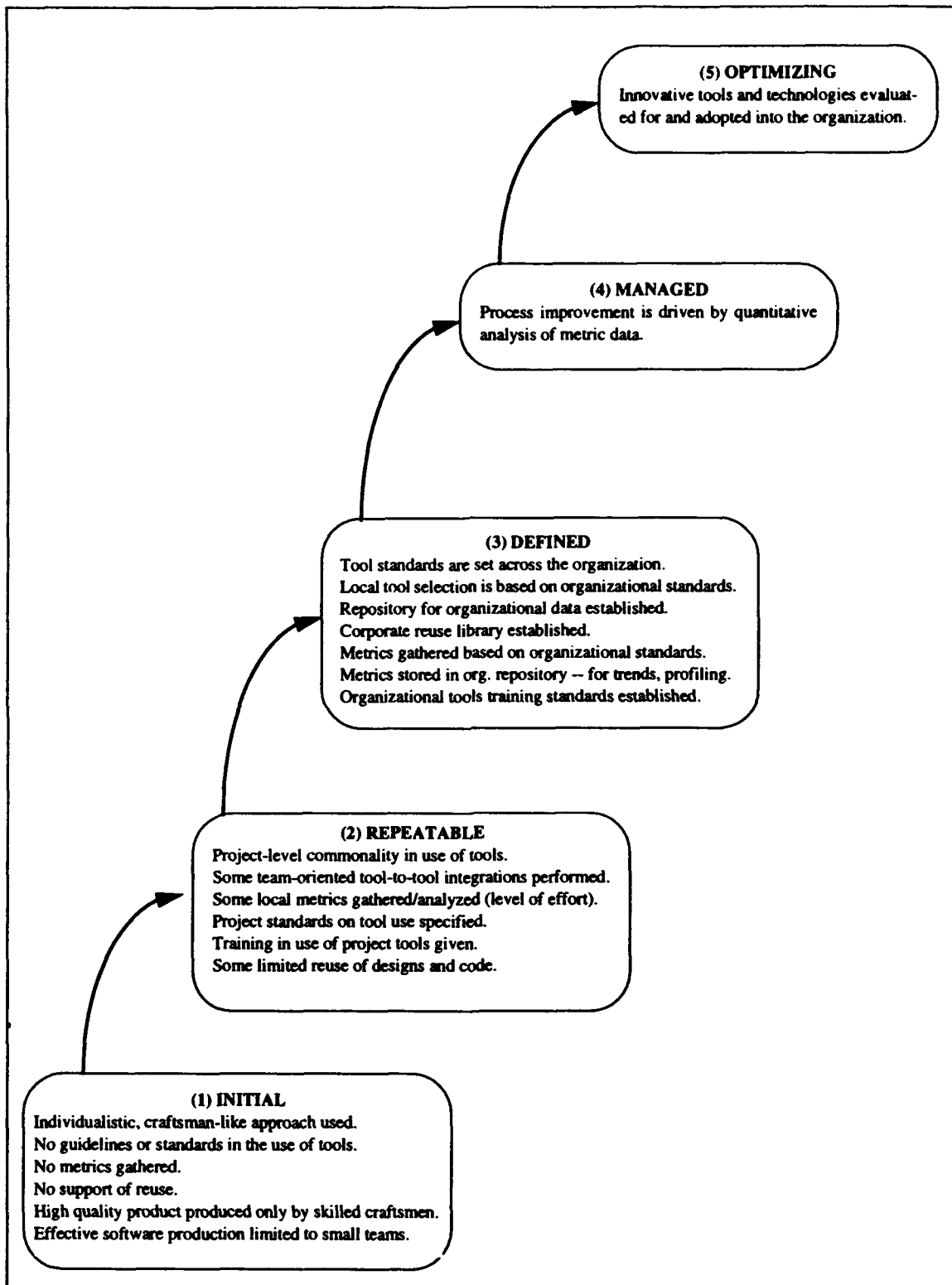

**Figure 2-2: Tool-Use Characteristics at the Five Maturity Levels**

broader set of functionalities can be invoked, since project processes can be enacted through the PCF.

## **2.3 Why Use a Process-Centered Framework?**

PCFs represent a new class of software that integrates the people in the organization with the development process and with the supporting technology. Unlike compilers, editors etc., PCFs primarily affect how work is performed rather than what is produced. PCFs provide the "glue" that actively manages the flow of work between people and their tools. Thus the issues that must be addressed in their adoption are significantly different from those for standard CASE tools. Some of these issues are already known through experiences with the software factory concept [Cusumano 91], but there may be novel issues that, because of the lack of practical application of PCFs in real-world settings, we have yet to discover. The primary motivations for using a PCF are improvement of quality and productivity; each of the items discussed below directly supports these goals. There are some significant advantages to using a PCF and some disadvantages. These are also discussed below.

### **2.3.1 Advantages of Using a PCF**

Use of a PCF inherently forces one to define one's processes in a rigorous enactable sense. This discipline alone is a major benefit. It allows for improved communication and understanding between the human participants and for consistency in how things are done. While use of a PCF cannot guarantee process improvement, used correctly it can certainly support the improvement effort by encouraging process definition and use. Training new employees in the process [Kellner 89] is supported both off-line and on-line. off-line support is available through use of the defined model to teach the novice the overall structure of the process. On-line, the novice (like other parties using the process) is guided through the process and thus requires a less detailed knowledge of the process in order to do his/her job effectively. In this way, fewer process-related errors are likely to be made. Whether the user is a novice or not, a PCF can eliminate the need for project personnel to perform many mundane tasks. Automated actions can be initiated on the basis of certain process states being reached, information can be presented to the user when appropriate, and messages can be sent between agents (human or not) when necessary.

As a by-product of having one's processes defined in an enactable sense, one can build up an enactable-process reuse library. This library can be of enormous help to others in the organization who have similar process needs [Kellner 93b]. Thus a project that has developed a particularly effective process (say, for peer review) can save the process in the corporate reuse library for access by others. By so encouraging this consistency and uniformity of process use, the organization is not only saving resources, but it is supporting Maturity Level 3 characteristics.

If a process cannot be measured, then improvement is a matter of opinion. However, collecting metric data manually has several drawbacks. First, developers generally do not want to waste their time manually filling out metric data forms, for either time-dependent data or code-dependent data, if they see no direct benefit to their work. Second, manually-generated data is likely to be error-prone and inconsistent,<sup>3</sup> particularly if the data is collected with resentment and suspicion. Resentment and suspicion are related to the issue of intrusiveness, that is, management "spying" on developers and using the collected data as fodder for job evaluations. However, this problem exists whether a PCF is used or not. (Suggestions for its solution are addressed later in Section 8.2.) Metrics collection and analysis can be major time consumers, and use of automation in this area could thus be a significant contributor to productivity. Of course, the collection of complete and accurate data also enhances product quality. Analyses of this metric data should lead to improved automated processes, and these improvements can then be permanently captured in the corporate reuse library.

In a traditional software development organization, it is often difficult for management to obtain current information on project status, etc., particularly if the project is large. Since the automated control of a process requires a current knowledge of task and product status, decisions taken etc., this information can also be made immediately available to management. Thus management can request reports on such current information as "list of tasks completed" or "status of change requests".

An indirect advantage of PCFs is that they may make CASE technology more effective. Earlier it was mentioned that CASE tools are too often viewed at a tactical level, that is, organizational issues such as process adoption and improvement are not seen as important elements to success. However, PCFs force one to address these very issues. Thus embedding CASE tools into a PCF may provide those CASE tools with a context to make them more effective.

### **2.3.2 Disadvantages of Using a PCF**

Besides the significant advantages described above, there are some potential pitfalls to using a PCF. First, not all software development organizations have characteristics compatible with high degrees of process automation. This is particularly true for organizations in which conceptually new software is being developed. These organizations may not easily be able to stabilize their processes and may have to operate in a craft manner (i.e., using small teams of highly competent professionals).

Second, the notion of letting a machine control how one works has negative connotations associated with mindless mass production. Designing an automated process to be human-compatible, while challenging, is critical to success. Thus, in addition to understanding the mechanics of building process programs, the designer of these processes must have insights into human behaviors, motivations, and expectations, and must be sensitive to the needs of the project for which the processes are being developed. As will be discussed later, it is prob-

---

<sup>3</sup>. Of course, automated collection of metrics can be prone to its own types of errors, for example, if the duration of a task is equated with the task effort.

ably essential for success that those who will use the automated processes should also be involved in their design. While management may see process automation as a means to control the developers (through, for example, greater access to status information), developers will only accept such automation if it is perceived to support their developmental needs (e.g., it liberates from chores rather than enforces unrealistic constraints). An example of a badly designed system might be one in which management can too easily spy on the minute-to-minute activities of developers.

Another pitfall in designing automated process models is the inability to handle unanticipated events. For example, the model may have to be modified during the project's execution in order to handle extra staff. Such events will surely occur. Thus, PCFs should contain mechanisms to allow the process designer to adapt processes during their real-time execution. *Because this activity may introduce erroneous process behavior, such modifications can have potential danger and must be managed very carefully.* In addition, there may be even more severe situations from which it is not possible to revert to an automated process. For these cases, built-in mechanisms to allow the process model to gracefully degrade to manual control should be considered.

A practical but important consideration is what might be called "process roll-back". Situations may occur, for example, where a technical error is made and not caught at the time. The process moves forward, and later on the problem is identified. With a non-automated process, there is likely to be sufficient flexibility within human control, so that manual corrections can be made. However, with the automation of a predefined process, reversing back to correct the problem will be much more difficult. In the simple case of a wrong button being pressed, an "undo" feature will be sufficient, but after a sequence of permanent changes have been committed, the complexity of the fix is much higher. Currently, the only practical solution may be to take the automated controller off-line, fix the problem manually, and then restart the controller.

### 3 An Experimental Investigation into PCFs

In order to better understand the technology behind process-centered frameworks, two products are examined. These products are ProcessWeaver, developed by Cap Gemini [ProcessWeaver 92], and SynerVision, developed by Hewlett-Packard [SynerVision 93a, SynerVision 93b]. These are typical of a new generation of commercially available products that have recently become available. Information to contact the suppliers of these and other PCFs<sup>4</sup> can be found in Appendix A.

#### 3.1 The Experimental Approach

To compare the technologies behind ProcessWeaver and SynerVision, a modified version of an evaluation methodology, developed for software engineering environments, is used [Weiderman 86]. This evaluation technique is based on several criteria which, in the context of this investigation, involve the following:

- Since detailed functionality may vary from PCF to PCF, the evaluation attempts to focus on the activities of the users of a PCF rather than the low-level features implemented in that PCF.
- The evaluation postpones the inspection of specific features of a PCF as long as possible. This approach forces one to keep a broad perspective and this helps with comparisons of PCF functionalities (as opposed to detailed implementation).
- The evaluation is based on a PCF-independent example of a process. This ensures that the PCFs are being assessed against the same criteria. It also reduces the effort since the same process model is used on each PCF.
- Objectivity and repeatability are assured through performing the same well defined tests on each PCF. Different experimenters, using the same process example, should come to the same or similar conclusions when evaluating the same PCF.
- Prior to examining the PCF, it may not be possible to determine all appropriate aspects of the evaluation. Thus the experimental approach should allow for iteration and refinement of the approach during the evaluation.
- The methodology should be extensible in the sense that the experiments can be easily modified, expanded and improved upon.

The original approach suggested by Weiderman focuses on end users. Such an application to project management tools is discussed in [Feiler 88]. However, in evaluating PCFs, there are two classes of user: the developer of the enactable process and the subsequent end-user of this process. Thus, the approach is modified somewhat to account for this difference. In addi-

---

<sup>4</sup>. Since SynerVision has some end-user applications built into it, it has some of the characteristics of a process-centered environment (PCE). However, for simplicity, both ProcessWeaver and SynerVision will be called process-centered frameworks (PCFs). See Appendix D for an elaboration of this issue.

tion, some of the original methodology has been simplified. These simplifications result in less formality and detail in the areas of evaluation questions than suggested in Weiderman's approach.

While Weiderman's approach involved six phases, the approach used here involves eight shorter phases. The details of these phases and the relationships between them are illustrated in Figure 3-1. The vertical line down the center of Figure 3-1 separates the development of the

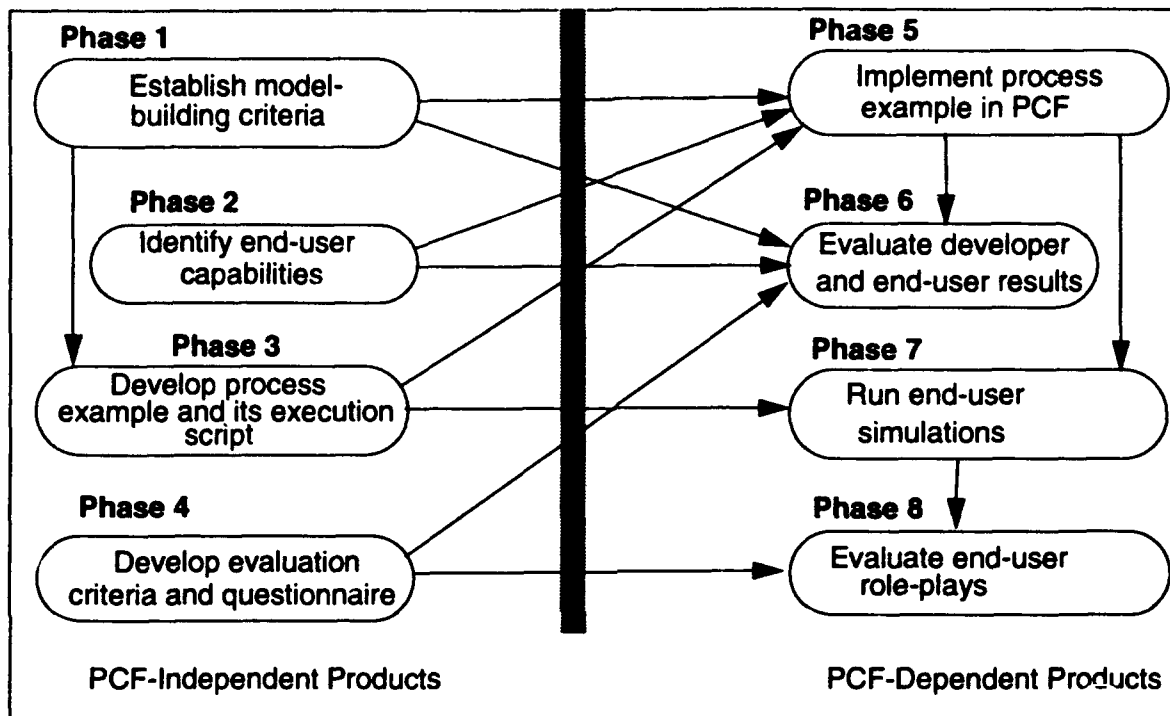

**Figure 3-1: Simplified Evaluation Process**

PCF-independent experimental set-up (Phases 1 through 4) from evaluations of each PCF (Phases 5 through 8), while the arrows represent dependencies. For example, Phase 1 provides Phase 3 with criteria on what is needed in the process model. A textual description of each phase is given below.

1. *Establish model-building criteria.* Establish the functional capabilities against which the PCFs are evaluated. This includes both the capabilities for developing and debugging process programs based on the process example. For example, we may wish to investigate the ability of the PCF to model the communication between agents (human or otherwise) or the ability of the PCF to perform syntax checking of the process program.
2. *Identify end-user capabilities.* Identify end-user capabilities that the PCFs might provide. Examples are: personal task management, project planning, or metrics collection. In reviewing these capabilities, one has to be careful not to conclude that product A is better than product B because it includes tool X. One design philosophy may result in a suite of tools being integrated into the product, while another design philosophy may focus on providing process mechanisms together with the capability for encapsulating tools.

3. *Develop process example.* Given the information of Phases 1 and 2, develop the process example against which the PCFs are to be tested. The process example developed for the evaluation is a document-modification process and was graphically defined using ProNet [Christie 93b]. Details of this example, which will be discussed below, is defined independently of the PCF on which it will later be implemented. An execution script is also developed to guide the end users through the end-user simulations (see Phase 7).
4. *Develop evaluation criteria and questionnaire.* Develop a set evaluation criteria, that are independent of both the PCFs and the process example, and against which both the developer and end-user evaluations will be performed. The criteria used are very similar to those identified in [Weiderman 86] and consist of such items as "ease of learning", "performance", "portability", etc. Also develop a questionnaire to be filled in by the role players of the end-user simulation.
5. *Implement the process example in the PCF.* In each PCF, implement the process example defined in Phase 3, using the Phase 1 criteria for guidance in the building process.
6. *Evaluate developer results.* With the experience gained from the PCF-specific model-building exercise (Phase 5), assess the capabilities of the PCF using the evaluation criteria developed in Phase 4, supported by the model-building criteria of Phase 1.
7. *Run end-user simulations.* Perform a set of end-user evaluations, in which several persons act out the process enactment scenario. These simulations will be guided by the execution script. A copy of the materials provided to the end-users (including the execution script) is provided in Appendix E.
8. *Evaluate end-user role plays.* Analyze the end user role-plays using the Phase 4 evaluation criteria. Also use the Phase 4 evaluation criteria to address end-user issues that are not part on the end-user process enactment scenario.

The next four subsections describe respectively the first four phases (i.e., the PCF-independent phases) of the of the experiment.

## **3.2 Model-Building Capabilities (Phase 1)**

In order to define the process example, a set of features that a PCF may be expected to support is identified. These features provide requirements for the design of the process example and are placed in the following categories given in Table 3-1: *development*, *enactment*, *resource*, *communications* and *debugging*. The categories are similar to those identified in [NIST 93] (See Appendix D). In addition, [Kellner 90] was reviewed in helping to identify some of the elements listed in Table 3-1.

**Table 3-1: Model-Building Capabilities**

1	Development issues	Discussion
a	Scoping of variables	If a process is composed of subprocesses, then there should be mechanisms for passing variable values from process to sub-process and back.
b	Modeling hierarchies	Models of any realistic complexity cannot be defined as one monolithic entity. Thus the PCF must allow activities to have internal structure (i.e., contain sub-activities) that can be broken out and defined separately.
c	Supporting model development	In order to construct process models, the PCF must provide support for model building. This support may be through a textual language with an editor, a graphical language, or a mixture of text and graphics.
d	Creating a process library	In order to enact a process multiple times, it must be possible to store the process program (i.e., the template) with its variables (e.g., roles) uninstantiated. See also item 2.a.
e	Supporting flexibility of task control	Humans perform tasks in an opportunistic manner that cannot always be predicted by a process model. For example it may be legitimate to prepare for a task before all the formal preconditions for the task have been met (as defined in the process model). Thus the ability to specify differing degrees of control over task initiation is desirable.
f	Modeling standard programming constructs	The process modeling language in a PCF must have a means of expressing the usual programming constructs such as iteration, conditional testing, and variable instantiation.
g	Performing parallel, aggregated processes	Consider the situation where twenty identical processes feed a downstream process. The PCF should have the ability to invoke the same template for all twenty upstream processes. Further, because the number of upstream tasks may not be known until run-time, it would be helpful if binding of these could be delayed until that time.
2	Enactment issues	Discussion
a	Assigning agents to roles	A PCF must be able to distinguish between roles (usually defined in the process model prior to run-time) and the agents who actually perform the actions (defined at the start and possibly throughout process enactment). The concept of roles and agents applies equally to humans and machines. The ability to instantiate roles with specific agents must be supported.

**Table 3-1: Model-Building Capabilities**

b	Supporting on-the-fly process modification	The ability to modify process models on the fly during execution may be important. Things go wrong during process execution, and changes may have to be made promptly. It may not be possible to wait until an automated process has terminated before modifying action can be taken.
c	Logging process data	Logging of process can be important in order to: 1) debug the process (see also item 5.g), 1) roll back an ongoing process to correct an error, 2) provide post-project verification that the defined process was followed, and 3) provide insights for the support of process improvement.
3	<b>Resource issues</b>	<b>Discussion</b>
a	Invoking tools	A PCF must provide the mechanisms through which tools can be invoked. Such invocation may involve simply starting the tool or it may involve accessing a specific aspect of its functionality.
b	Managing objects	There is a close relationship between the tasks in a process and the artifacts produced by the tasks. These artifacts may be versions of a product. Thus, having some means to manage versions of products is a useful capability.
4	<b>Communication issues</b>	<b>Discussion</b>
a	Modeling communication between agents	Central to process enactment is the notion of communication, either from human-to-human, human-to-computer-agent, computer-agent-to-human and computer-agent-to-computer-agent. The PCF must provide mechanisms for such communication.
b	Modeling automatic actions	As a result of an event occurring, automatically triggered actions may be necessary. These actions may send messages to humans or may trigger other automatic events. Means to model automatic actions must therefore be provided.
5	<b>Debugging issues</b>	<b>Discussion</b>
a	Checking syntax	This is the ability to identify and clearly define the source of programming errors.
b	Performing reachability analysis	This is the ability to evaluate an enactable process model to assure that all of its parts are accessible during process enactment.
c	Performing deadlock analysis	This is the ability to evaluate if there are process states from which it is impossible to exit.
d	Tracing process dynamics	The ability to trace the dynamics of the process as it is being enacted can provide significant insights for process model validation.

**Table 3-1: Model-Building Capabilities**

e	Querying	This is the ability to check on the values of variables during process enactment (simulation or actual use).
g	Spying	This is the ability to insert breakpoints in the simulation of a process in order to examine the status of variables, etc.
g	Logging process data	See 2.c above.

### 3.3 End-User Capabilities (Phase 2)

End-user applications may be built in (as part of a PCE) or through the invocation of external tools (as in a PCE or PCF). In either case, application tools will be needed to support the large majority of processes. Some of the capabilities which are particularly well suited to integration in a PCF or PCE are reviewed in Table 3-2.

**Table 3-2: End-User Capabilities**

	Application	Discussion
a	Scheduling periodic work	A simple but important application of process support is the ability to initiate tasks (e.g., time card generation) or present personal reminders (e.g., weekly meetings) on a periodic basis.
b	Collecting metric data	A PCF provides many mechanisms which can facilitate the automatic collection of process and product metrics.
c	Supporting project management tasks	Both process enactment and project management require information on tasks, resources, and agents and the relationships and dependencies between them. Thus there is significant overlap in the data needs of process enactment and project management and each can leverage off the other.
d	Supporting the individual user	There are many modest personal tasks with which process automation can help. Examples include: managing "to do" lists, planning work estimates, tracking work effort, and capturing personal metrics.
e	Supporting group communications	A variety of group activities do not require a full process model to drive them. Examples include: delegating, negotiating, reassigning and coordinating tasks.

### 3.4 Process Example and Its Execution Script (Phase 3)

All of the items in Table 3-1 (with the exception of debugging issues) influenced the design of the process example in some significant way. This example portrays a simple document update process and is formally defined using ProNet notation [Christie 93a, Christie 93b, Earl 93].<sup>5</sup> A brief review of this notation is also provided in Appendix C. The elements of the example, illustrated in Figures 3-2, 3-3, and 3-4, are described below.

<sup>5</sup> Note that the ProNet graphical symbol set used in the first two of these documents is more limited than used in this report (see Appendix C for current symbol set).

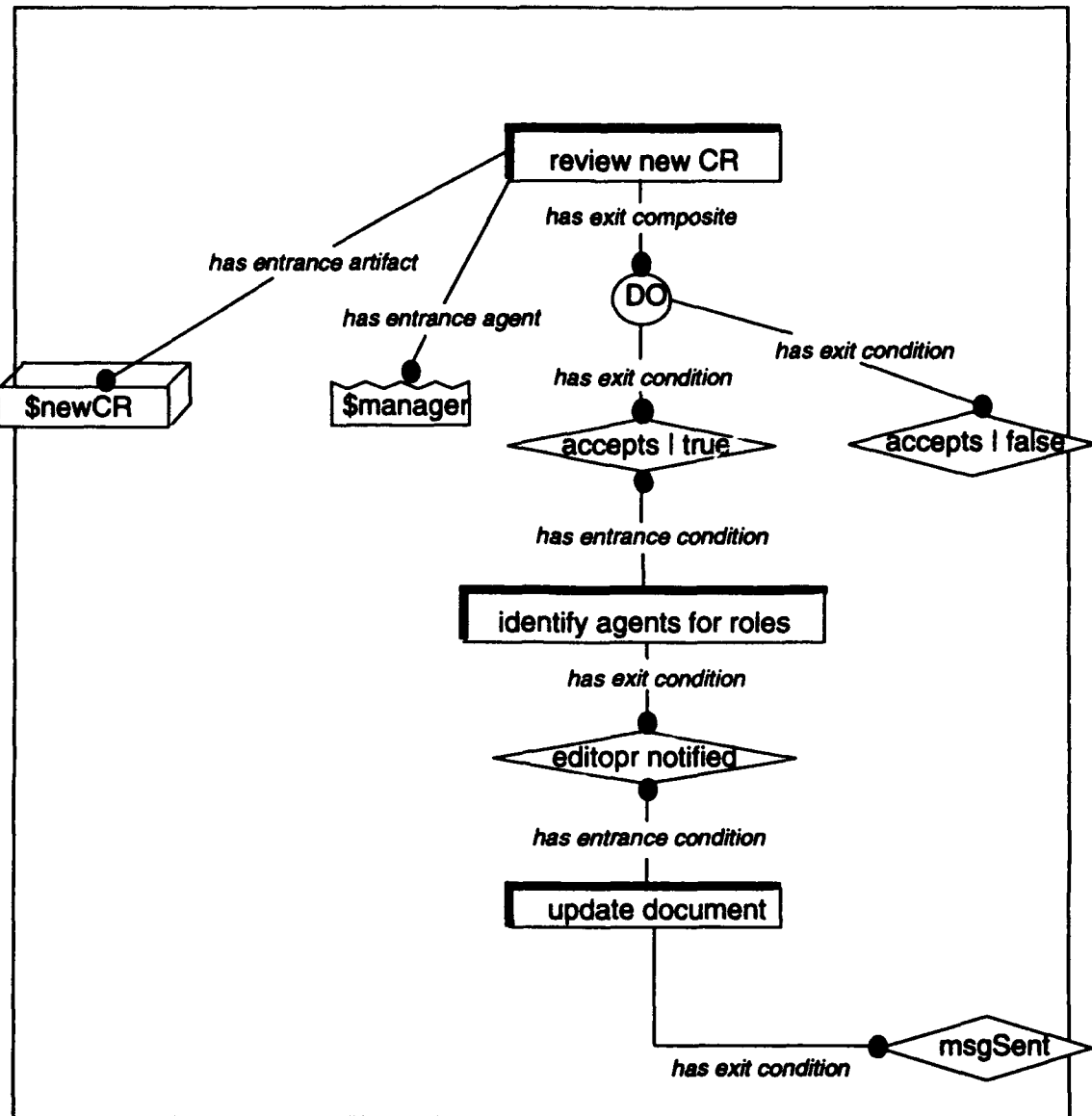

**Figure 3-2: The *Modify Document* Process**

The group that performs the document modifications consists of a manager and two technical writers. Following the process flow, shown in Figure 3-2, the manager receives a change request (CR) from outside and determines through the process *review new CR*, if it is appropriate for processing. If it is, then there is a selection process, *identify agents for roles*, that determines who will perform the editing function and who will perform the review function. Finally there is the update process, *update document*, in which the changes are actually made. The latter two processes have lower level detail, and this exercises the PCF in the ability to model hierarchies.

The *identify agents for roles* process, shown in Figure 3-3, contains elements to exercise communication and automatic action facilities in the two PCFs. The manager makes an initial assignment of roles (*make initial assignments*), and these roles are communicated to the two

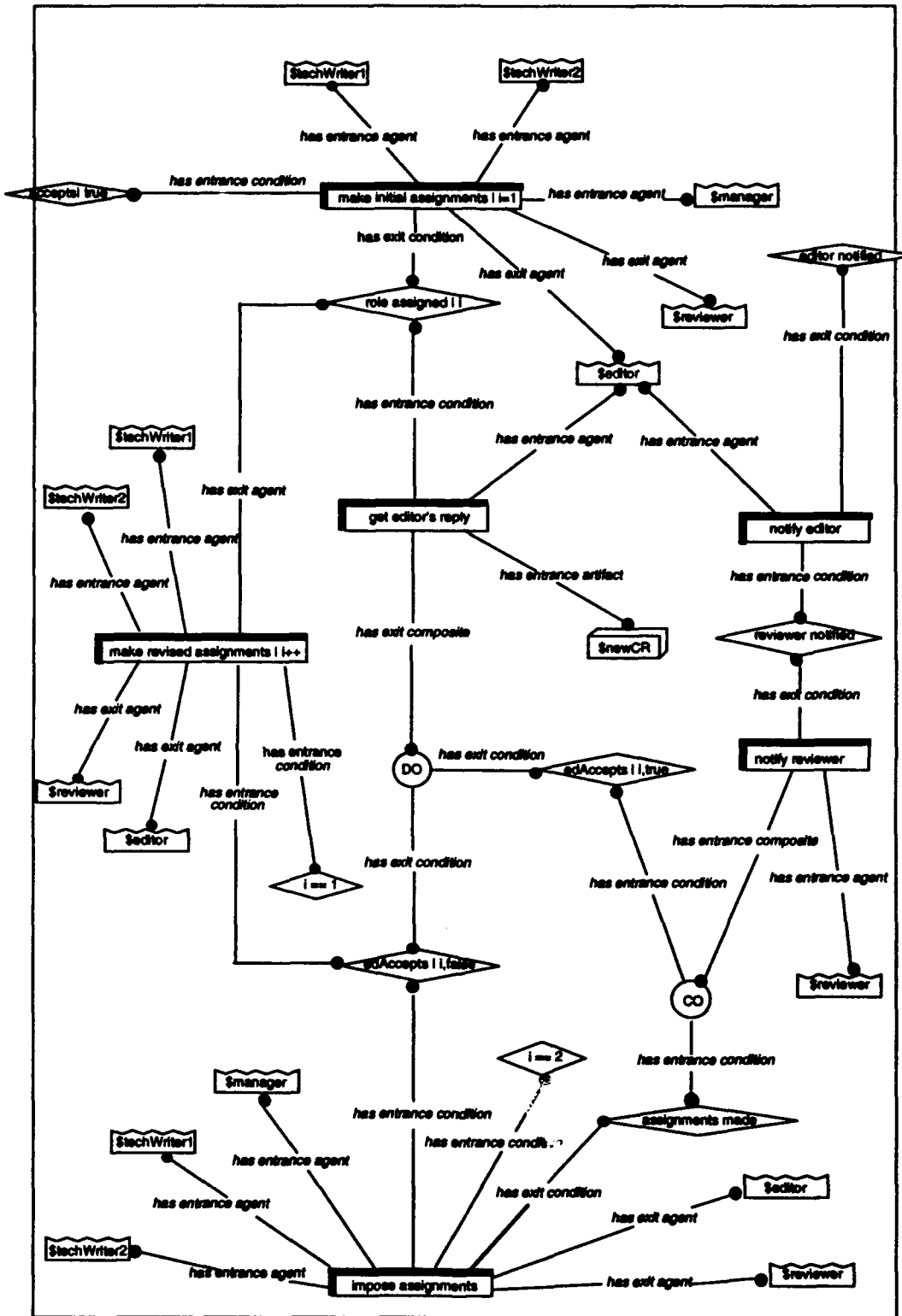

Figure 3-3: The *Identify Agents for Roles* Process

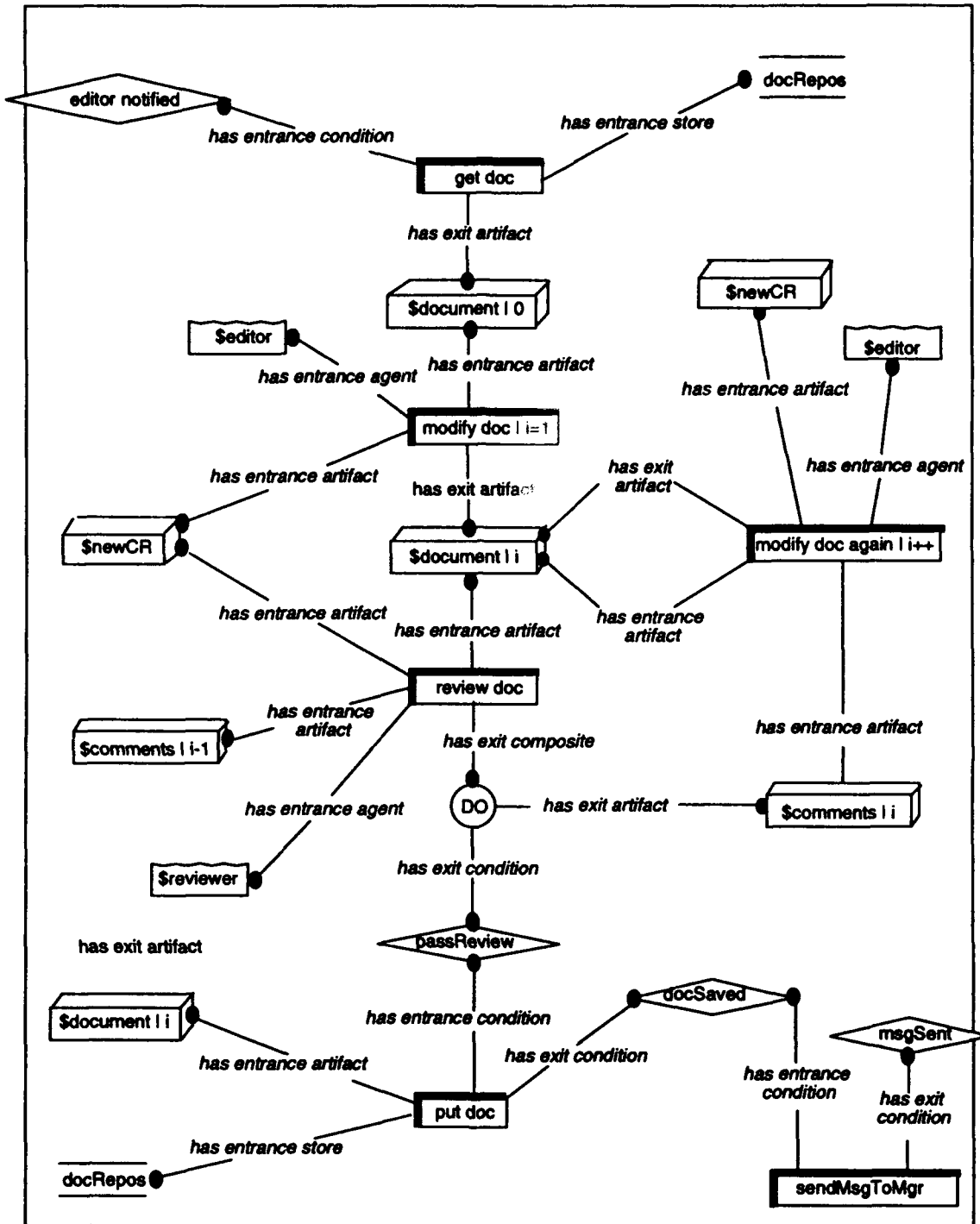

Figure 3-4: The Update Document Process

individuals. The person assigned the editor role can accept or reject that role (*get editor's reply*). If the reply is "accept", then the other person is automatically notified through the *notify reviewer* activity that he/she has been given the reviewer role. If the first person rejects the editor role, then the second person is automatically requested to take on the editor's role

*(make revised assignments)*. This person can also accept or reject the editor's role. If "reject" is selected, then the manager is notified and a manual assignment is made through the activity *impose assignments*. In this case the writers are notified of the manager's decision (through the *notify editor* and *notify reviewer* tasks).

The remaining high level process, *update document*, is shown in Figure 3-4. To perform the tasks in this process, the document is removed from a simple repository, edited, reviewed, and then replaced into the repository. Thus some simple SCM functionality is required. The process starts with the system extracting the document from the repository and presenting it to the editor (*get doc*). The editor then revises it as described in the change request (*modify doc*). After the modified text has been reviewed (*review doc*), the document is then either approved by the reviewer or sent back to the editor with review comments for further modification together. If the reviewer approves the changes, the document is put back into the repository and the manager is notified that the process is complete (*put doc*).

Note that items 1a, 1b, 1c,1d, 1f, 2a, 3a, 3b, 4a, and 4b of Table 3-1 are explicitly tested by the process example. It should also be noted that there are many aspects of the two PCFs being addressed that are not being tested. For example, both PCFs have significant capability in the area of external communication and tool encapsulation.

The execution script for the process example is now reviewed. Appendix E provides the evaluation materials which were given to the participants of the end-user evaluations. This script, which is part of the end-user evaluation materials, is shown in Table E-1 and follows one of many possible process scenarios. In this particular scenario, the manager receives an incoming change request to modify a document (item 1 in Table E-1) and identifies his initial choice of editor (item 2). Both technical writers (A and B) initially refuse to accept the role of editor (items 3 and 5), and this forces the manager to impose the editor role on Technical Writer A (items 7). After Technical Writer A has performed the requested modification (item 10), the documents are sent for review to Technical Writer B who in turn adds a comment in the supporting document *Review Comments* (item 11). The task is then automatically sent back to Technical Writer A who again edits the document (item 12), after which it is sent back to Technical Writer B for a second review. At this point, Technical Writer B accepts the modification (item 13), the document is automatically saved in the repository, and the manager is notified that the modification has been successfully completed (item 14).

### 3.5 Evaluation Criteria and Questionnaire (Phase 4)

In order to assess the adequacy of the two PCFs, a set of evaluation criteria are established. These criteria are defined independently of the model-building capabilities (Phase 1) and the process example (Phase 2). They are, in fact, a modification of the set suggested in [Weiderman 86], and are shown in Table 3-3. These form the basis for the evaluation which the author

**Table 3-3: PCF Evaluation Areas**

1	Functionality	a) Completeness of major functional areas for development, as identified in Tables 3-1. b) Completeness of end-user functional areas as defined in Table 3-2.
2	Developer issues	a) Ease of learning. b) Ease of use. c) Effectiveness of support for development. d) Quality of on-line help. e) Error handling.
3	End-user issues	a) Ease of learning. b) Ease of use. c) Clarity of presentation.
4	Performance	a) Execution time efficiency. b) Space efficiency.
5	System interface	a) Ease of tool integration. b) Portability. c) Interface to operating system.
6	Off-line user support	a) Support from customer representatives. b) Clarity of documentation. c) Availability of hands-on training. d) Availability of encoded process examples.

performed. Also, an end-user questionnaire is developed. This questionnaire, shown in Table E-2, lists the questions that the role players answered after performing in the simulated document update process. An analysis of the responses to these questions is provided in Section 6.

In summary the sequence of tasks that will be performed using SynerVision and Process-Weaver is as shown in Figure 3-5.

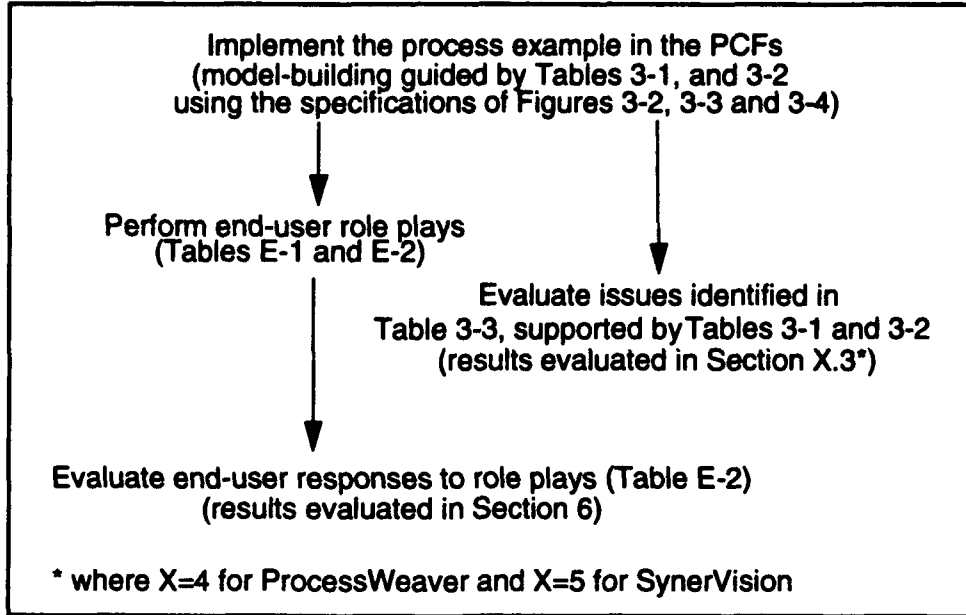

**Figure 3-5: Sequence of Evaluation Tasks**

## 4 The ProcessWeaver Experiment

### 4.1 Review of ProcessWeaver

ProcessWeaver provides a suite of tools for the management of individual tasks and for process automation (i.e., sequences of tasks). The end user of ProcessWeaver is provided with a main window called the *Agenda*, and it is through this window that tasks, called *Work Contexts*, are sent, received, or worked on. Work Contexts appear as icons in the Agenda and can be opened to provide detailed tasking information. In addition, there are several windows to support the development of processes. These are the *Method Editor*, the *Activity Editor*, the *Cooperative Procedure Editor*, and the *Work Context Editor*. The Method Editor provides the capability for defining activity hierarchies, while the *Activity Editor* allows task inputs, outputs, and roles for these activities to be specified. Through the Cooperative Procedure editor, one can model the detailed task-level processes for each activity. Finally, the windows through which the end user performs tasks, are designed using the Work Context Editor. These elements of ProcessWeaver are reviewed in more detail in the following subsections. The final subsection (4.1.6) provides an "integration" view, since there are many components to ProcessWeaver and the relationship between these components is not at first obvious.

#### 4.1.1 Agenda Window

The Agenda window acts as a central location for managing an individual's tasks. The current tasks are displayed as icons in the Agenda window as shown in Figure 4-1. In this instance, the task *UpdateDocument* is the Work Context icon. These tasks may either be isolated "to do's" or may be elements of a more complex process. If they are isolated "to do's", they may be delegated from someone else or they may originate locally from the person who "owns" that Agenda. In the latter case, the Work Context could reflect a personal task that has to be performed on a periodic basis (e.g., defining monthly objectives) and automatically appears on the first day of the month. Delegation of a task is performed simply by dragging the Work Context icon over to the Delegation icon (the report) on the right of the window. This generates a predefined list of candidates, from which one or more are selected. A completed task can be eliminated by dragging its icon over the garbage can icon.

The menu bar along the top of the window provides a variety of options. The *Weaver* option allows one to access the editors for Work Contexts, Cooperative Procedures (i.e., processes), and Methods (i.e., activity hierarchies). The *Work Context* option primarily allows one to select individual Work Contexts to be instantiated for a specific task and perhaps delegated. The *Procedures* option allows one to generate a new instance of a process, while the *Preferences* option allows one to customize some setup parameters, such as setting an alarm when a Work Context is received.

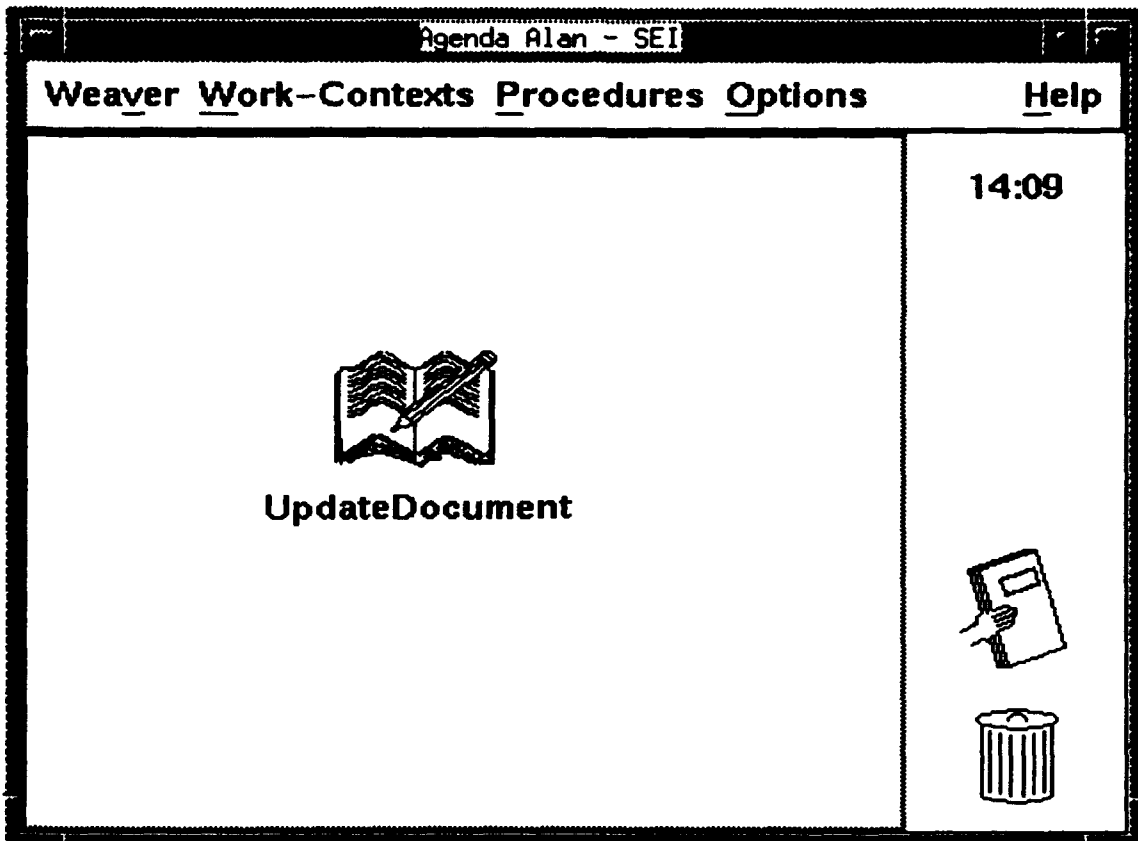

Figure 4-1: An Agenda Window

#### 4.1.2 Work Context Window

On double clicking a Work Context icon in the Agenda window, its associated window appears. A typical Work Context window is shown in Figure 4-2. Notice that there are three different types of objects. These are: message boxes, icons representing elements of the task to be worked on, and control buttons. These three items are all the object types that need to be supported by Work Contexts. In the message box, variables can be embedded in the text. Thus in the example above, a role variable (e.g., *\$person*) can be instantiated at run-time with a name (e.g., *Alan*). These boxes can also be used to input information into the process. By clicking on an icon, the user can activate the corresponding object. This could be a text editor, compiler, or CASE tool.

Individual Work Contexts can be developed or modified using the Work Context editor. This function allows the developer to customize Work Contexts with any combination of text boxes, icons and buttons that is appropriate to support the end user. A wide variety of icon designs is provided, and one can associate an icon with an appropriate tool or document. A default tool set is provided and this set can be extended by the developer if necessary. Buttons are given identifiers so that they can be associated with a particular decision path of a process model.

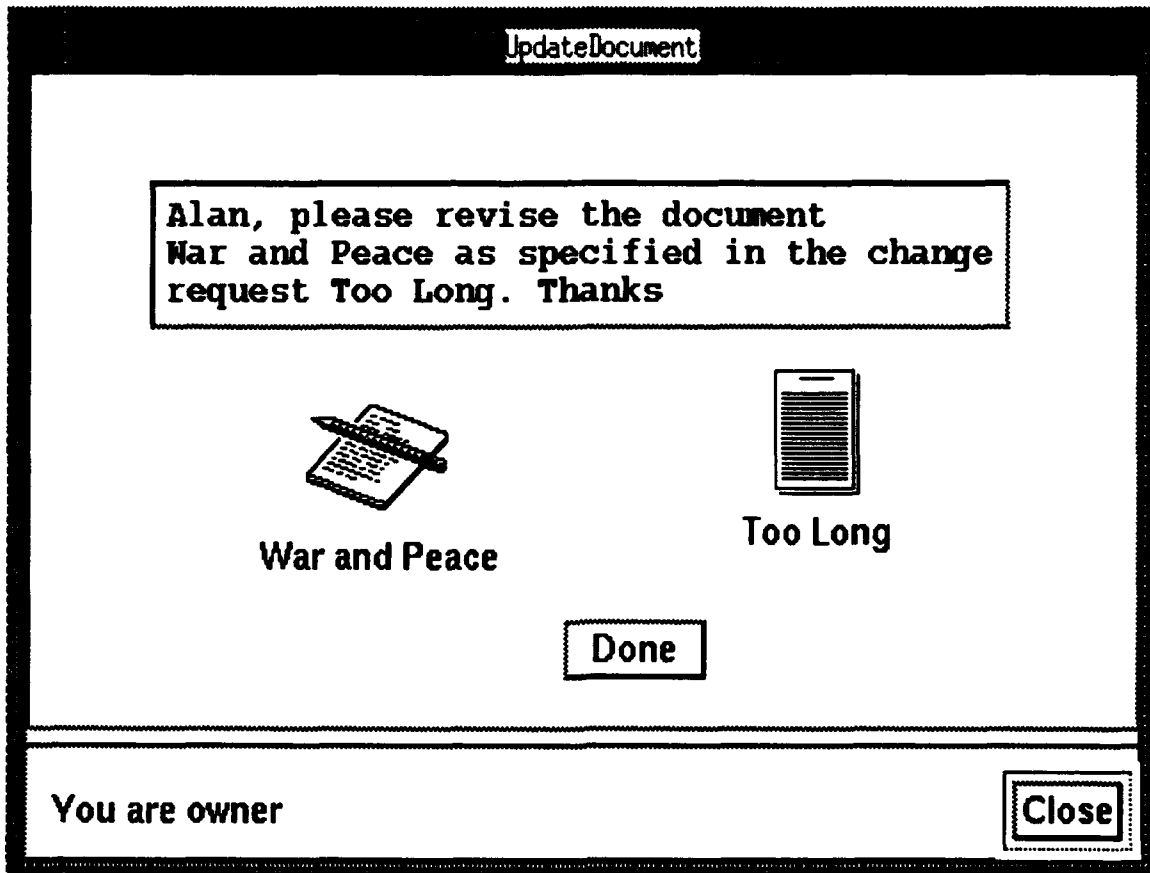

Figure 4-2: A Work Context Window

#### 4.1.3 Method Editor

As mentioned above, the two previous views (the Agenda and the Work Context) support the end user of the process while the next three views (the Method, Activity, and Procedure Editors) support the process developer. ProcessWeaver models projects by structuring them into a hierarchy of activities. An example of a simple hierarchy is shown in Figure 4-3. The window in Figure 4-3 supports a variety of functions. First through the *Edit* option one can add, delete, and append both activities and decomposition levels to the hierarchy. Through the *Check* option one can examine measures related to, for example, the consistency of input and output products between activities, and this can be very useful for the verification of large models. The *Run-time* option allows one to generate simple default cooperative procedures (processes) automatically that are attached to the activities; these are discussed in Section 4.1.5. Each of the activities has associated with it an *Activity Editor* that defines the inputs required by that activity, the roles required to support the activity, and the outputs generated by that activity.

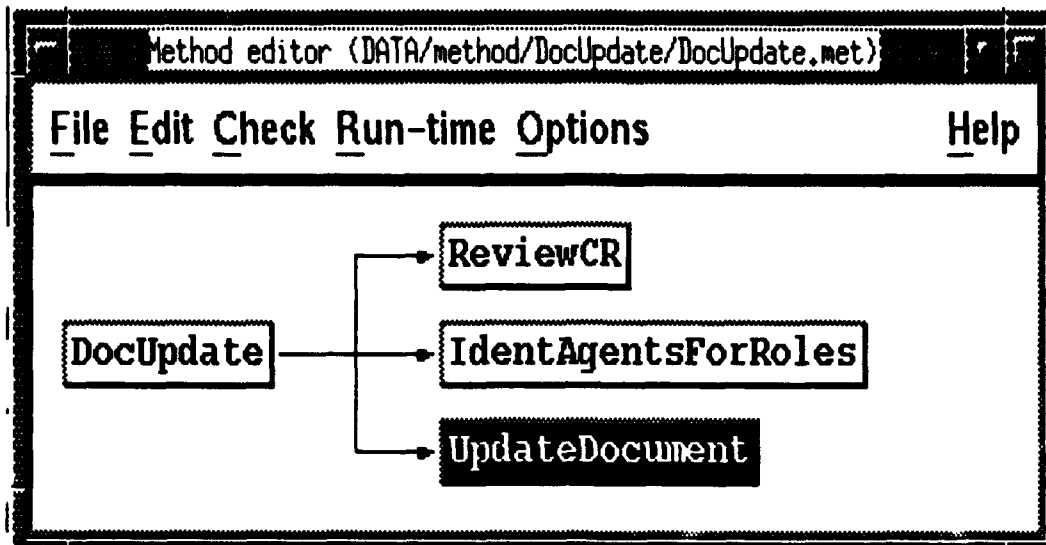

Figure 4-3: A Method Editor Window

#### 4.1.4 Activity Editor

Each Activity Editor window displays information related to one activity; a typical Activity Editor window can be seen in Figure 4-4. This window can be accessed for a particular activity by double clicking on that activity in the Method Editor window. The main items displayed in the Activity Editor window are the inputs, outputs, and roles associated with the activity. It is these items against which the Methods Editor can perform consistency checking, over the whole process model, as discussed in Section 4.1.3. By clicking on the Edit button, one activates the Cooperative Procedure Editor window.

#### 4.1.5 Cooperative Procedure Editor

The Cooperative Procedure window defines the detailed processes using a Petri net [Reisig 82] notation. A very simple default process model is illustrated in Figure 4-5. Petri Nets were initially developed to model synchronous and asynchronous events in communication systems and have been adapted by ProcessWeaver for process definition and enactment. These nets consist of three kinds of elements that can be displayed graphically: *places* (denoted by circles), *transitions* (denoted by rectangles), and *directed arcs*. Arcs connect places to transitions and transitions to places. In addition, the concept of *tokens* (that are inserted into places) is used for process enactment to mark a place that has been asserted in some way (e.g., made TRUE). If a token is in a place, then all the arcs emanating from that place are said to be *loaded*, and if all the places leading to a transition have tokens, then the transition is said to be *enabled*. Within this process context, transitions represent state changes while places represent states. Thus, when a condition is satisfied, and the associated action taken, the process can transition from one state to the next.

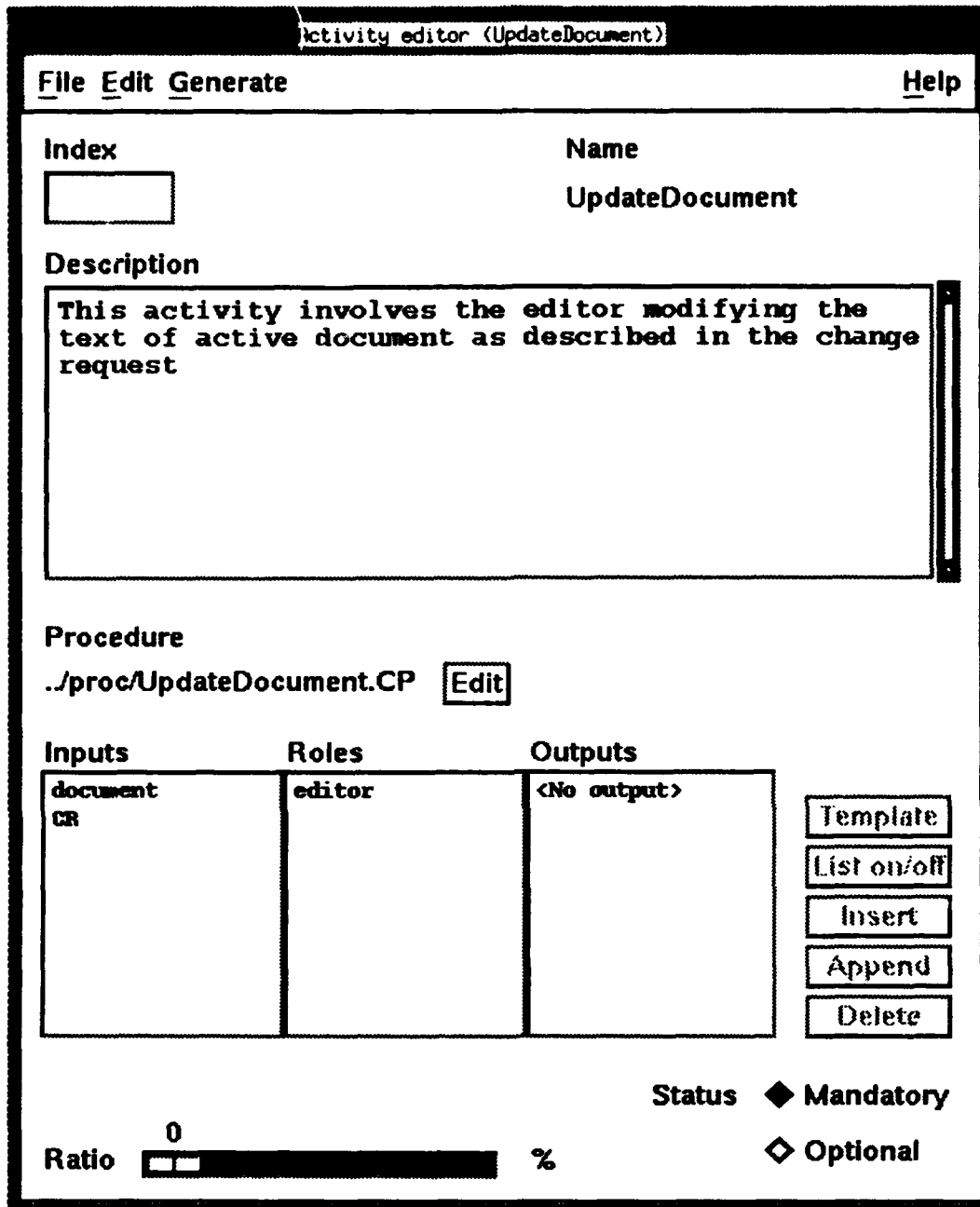

**Figure 4-4: An Activity Editor Window**

In Figure 4-5, the process begins at the place with the inserted token. An event at the next higher level in the activity hierarchy may initiate this sub-task. The *Perform\_Update* transition has no entrance condition. The window associated with the action (not shown) provides three elements. First, actions can be taken by executing some code written in ProcessWeaver's Co-shell scripting language. Second, the agent who will perform the action is identified. Finally,

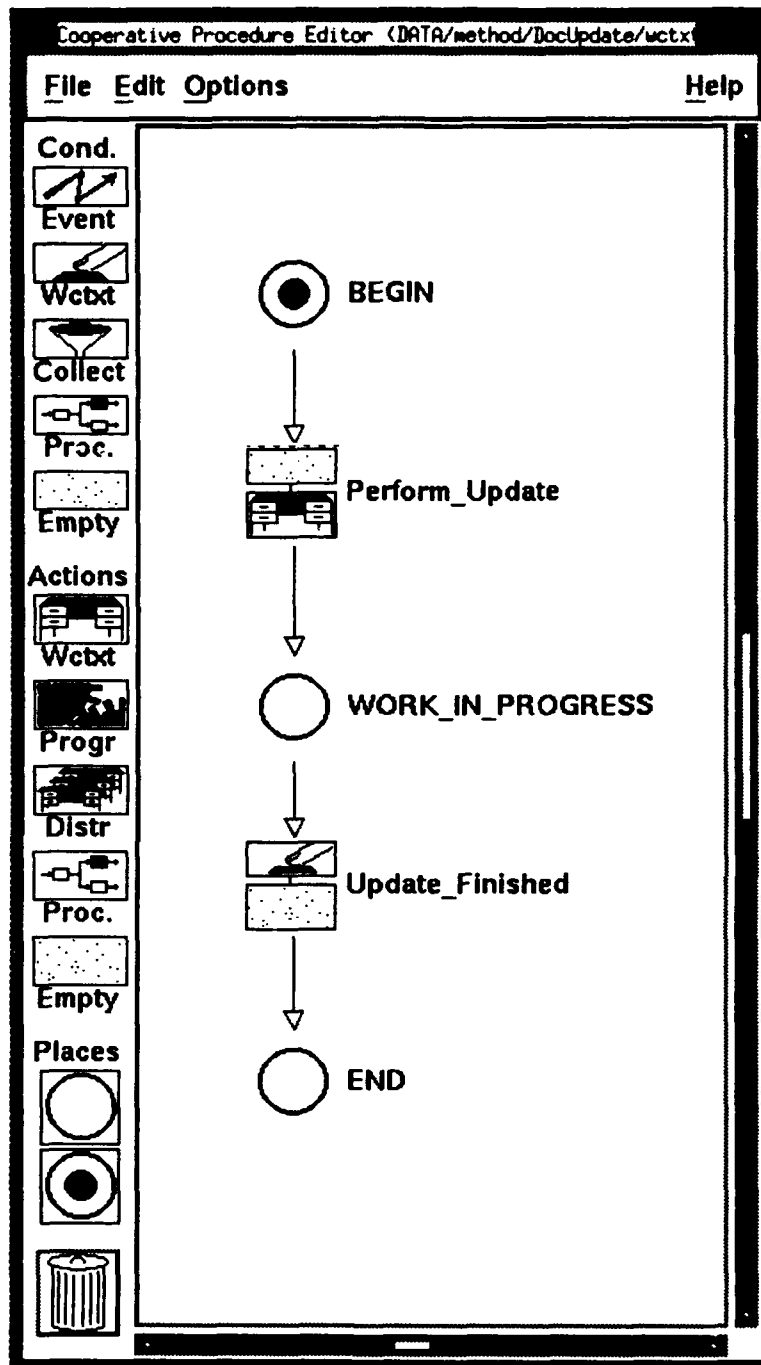

**Figure 4-5: A Cooperative Procedure Window**

the Work Context, that will be sent to the agent, is identified. When the agent has finished the work, the *Done* button (defined in the Work Context) is pressed, and the token moves to the place marked *END*.

Down the left hand side of the Cooperative Procedure window is a set of transition icons. The graphical part of the process model can be rapidly constructed simply by dragging icons from the left-hand edge of the window and placing them in the model definition area. These can then be connected by dragging a line between (legally-connected) icons. In the graphical model, each transition is composed of two parts — a condition part and an action part. Upon double clicking one of these icons, an information box, customized for that type of icon, appears and lets the model developer enter appropriate information. During execution, the condition part must be satisfied before the action part can be initiated. In addition to the null (always true) condition, there are four other types of condition (Event, Wctx, Collect and Proc). These are described briefly below:

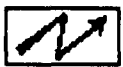

*Event*. This icon implies “waiting for an external event”. For example, it could mean that some set of external logical conditions has occurred, such as a word processor updating a file, in conjunction with “Joe” being the editor on that file. External events can also include events on the ProcessWeaver communication bus.



*Wctx* (work context). This icon implies that a cooperative procedure is waiting for an answer from a work context currently being performed. For example, when a button named *Done* is pressed inside a work context, the Wctx condition is set to TRUE.



*Collect*. This icon evaluates a set of conditions — either work contexts or events. It can be made to fire when all the incoming conditions are TRUE or when only one of the incoming conditions is TRUE.



*Proc*(edure). This icon waits for a given state (e.g., completion) of a sub-process previously launched.



*Empty*. This icon implies that the condition is always TRUE.

In addition, there are five types of action, each action having an associated icon. The action associated with one of these icons is taken when the corresponding condition is TRUE. These actions are named: Wctx, Progr, Distr, Proc, and Empty. These are briefly described below:



*Wctx* (work context). When this icon is activated, a work context is sent to the person designated in an information box attached to this icon.



*Progr* (programming). Allows one to describe required actions, using ProcessWeaver’s Co-shell programming language. This language provides many functional features such as:

- manipulation of variables and lists,
- ability to perform arithmetic and logical operations, and provision for constructs in tests, and control, etc.;

- communication with users through work contexts;
- manipulation of events on ProcessWeaver's communication bus through constructs that are similar to Hewlett Packard's Broadcast Message Server; and
- support for development of user-defined Co-shell functions.



**Distr (distribution).** This icon allows for the sending of a work context to multiple recipients. Its behavior is similar to the *Wctxt* action.

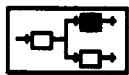

**Proc(EDURE).** This icon initiates a sub-process of the current process at run-time.



**Empty.** This icon implies that there is no action.

#### 4.1.6 Pulling the Elements Together

Given the number of elements that contribute to a ProcessWeaver model it can be a challenge for the novice to understand how all these elements tie together. Figure 4-6 provides a simplified description of such an integrated picture. For the process developer, the *Method Editor* provides a hierarchical view of the major activities. Each of the activities defined in the *Method Editor* window has two associated windows: an *Activity Editor* that specifies the inputs, outputs, and roles required for the activity, and a *Cooperative Procedure Editor* that defines the lower level elements of the process using the Petri net notation. Each transition in the Petri net is composed of a condition part and an action part, the action taking place when the condition is met.

In the end-user view (at run-time), a process template is instantiated by a user (e.g., project manager) who invokes an existing *Cooperative Procedure* under the *Procedures* menu in the *Agenda*. This user does not see the Petri net process model, but is presented with a window (not shown) in which the roles, documents and other artifacts to be used in this specific process are instantiated. For example, the role *\$editor* may be instantiated with the specific agent (e.g., *Alan*) who carries out the operation, while the file to be modified, *\$doc*, may be instantiated by the document *War and Peace*. Upon receiving this information, ProcessWeaver can start to enact the process (initiating Work Contexts, performing automatic tasks, etc.).

Through its activities, a cooperative procedure may perform a variety of types of functions. These were reviewed in Section 4.1.5. One of the important types of function is to be able to send Work Context messages to human agents who are responsible for tasks. These messages appear on the receiver's *Agenda* window as Work Context icons. (In Figure 4-6, the task is *UpdateDocument*.) On opening the icon to view the full Work Context window, the agent should find sufficient information to perform the task. In the example shown in Figure 4-6, a document icon (*War and Peace*) is seen on the Work Context window, and when this is

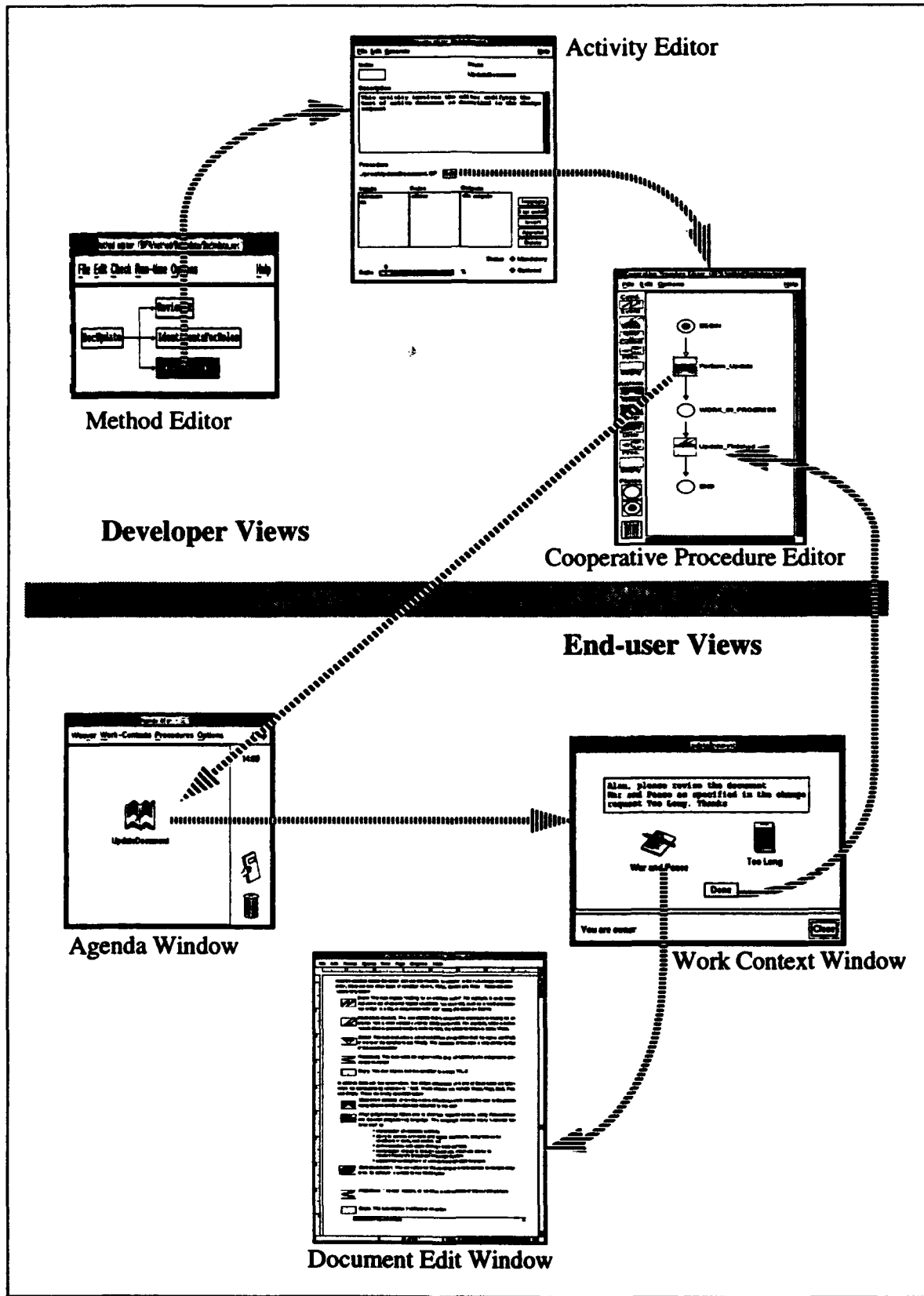

**Figure 4-6: Overview of ProcessWeaver Elements**

opened, the actual document to be worked on appears. Note that you can also open the change request *Too Long* as well. When the task has been completed, the *Done* button on the Work Context window is pressed. This state change, resulting from pressing the button, is detected by the *UpdateFinished* condition in the Cooperative Procedure which then allows the process to move forward.

## 4.2 Developing the ProcessWeaver Process Model

To develop the ProcessWeaver model, it was originally intended that the activity hierarchy shown in Figure 4-3 be used. However, this had to be modified because of a variable scoping problem that was encountered. It was intended that the persons taking on the roles of editor and reviewer be identified in the sub-activity *IdentAgentsForRoles*. However, as ProcessWeaver is currently structured (in Version 1.2), a variable that is instantiated in a certain activity can only have the instantiated value used in that activity or in child activities. Hence the activity structure had to be simplified as shown in Figure 4-7. The activity *ReviewIdentify* in Fig-

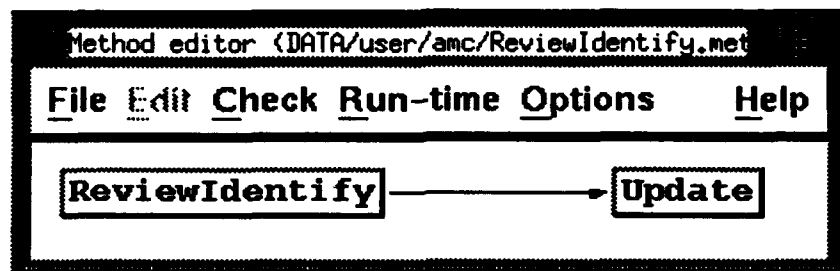

Figure 4-7: Activity Hierarchy for the Example Process

ure 4-7 thus includes the parent activity (*DocUpdate*) and the child activities (*ReviewCR* and *IdentAgentForRoles*) shown in Figure 4-3. The Cooperative Procedures for *ReviewIdentify* and *Update* are shown in Figures 4-8 and 4-9 respectively.

The upper part of Figure 4-8 defines the process through which the manager reviews the change request. To do this review, a Work Context is displayed on the manager's terminal allowing the CR to be accessed for review and providing accept and reject buttons. Figure 4-8 shows the two paths taken depending on his choice. The second part of the figure defines the process for selecting the editor and reviewer. The logic of this process is the same as that of Figure 3-3, although the implementation is modified to conform with ProcessWeaver's Petri net notation. Note that this graphical model is not sufficient to completely define the process model; fragments of co-shell scripting are associated with many of the transition icons.

Figure 4-9 is a fairly straightforward adaptation of Figure 3-4. The document is checked out of the repository, modified by the editor, and sent to the reviewer. If the reviewer passes the document, the updated version is checked back into the repository. Otherwise, the modifications are rejected by the reviewer, and the document is passed back to the editor with suitable comments in a *review comments* notebook. Check-out and check-in are implemented using the

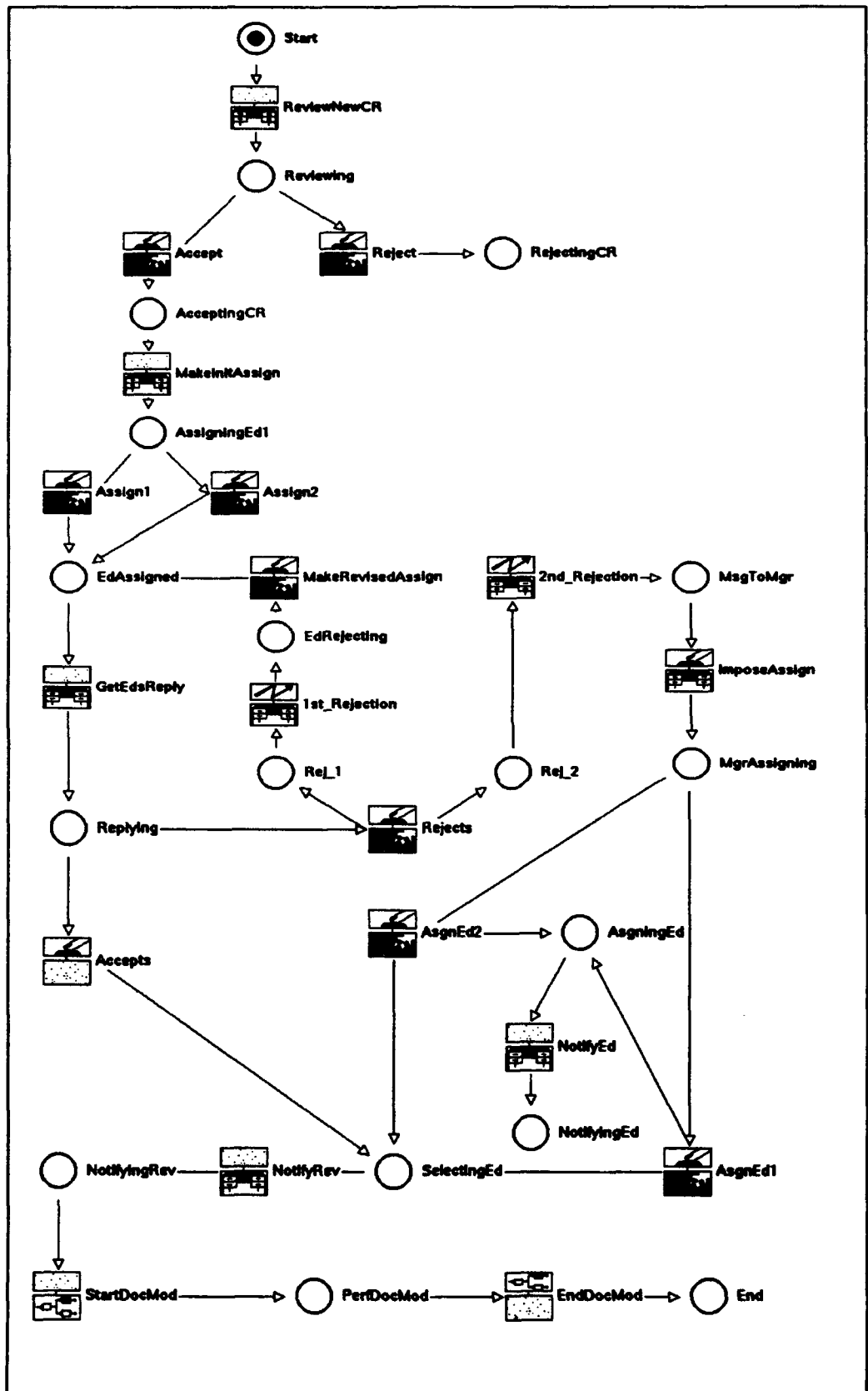
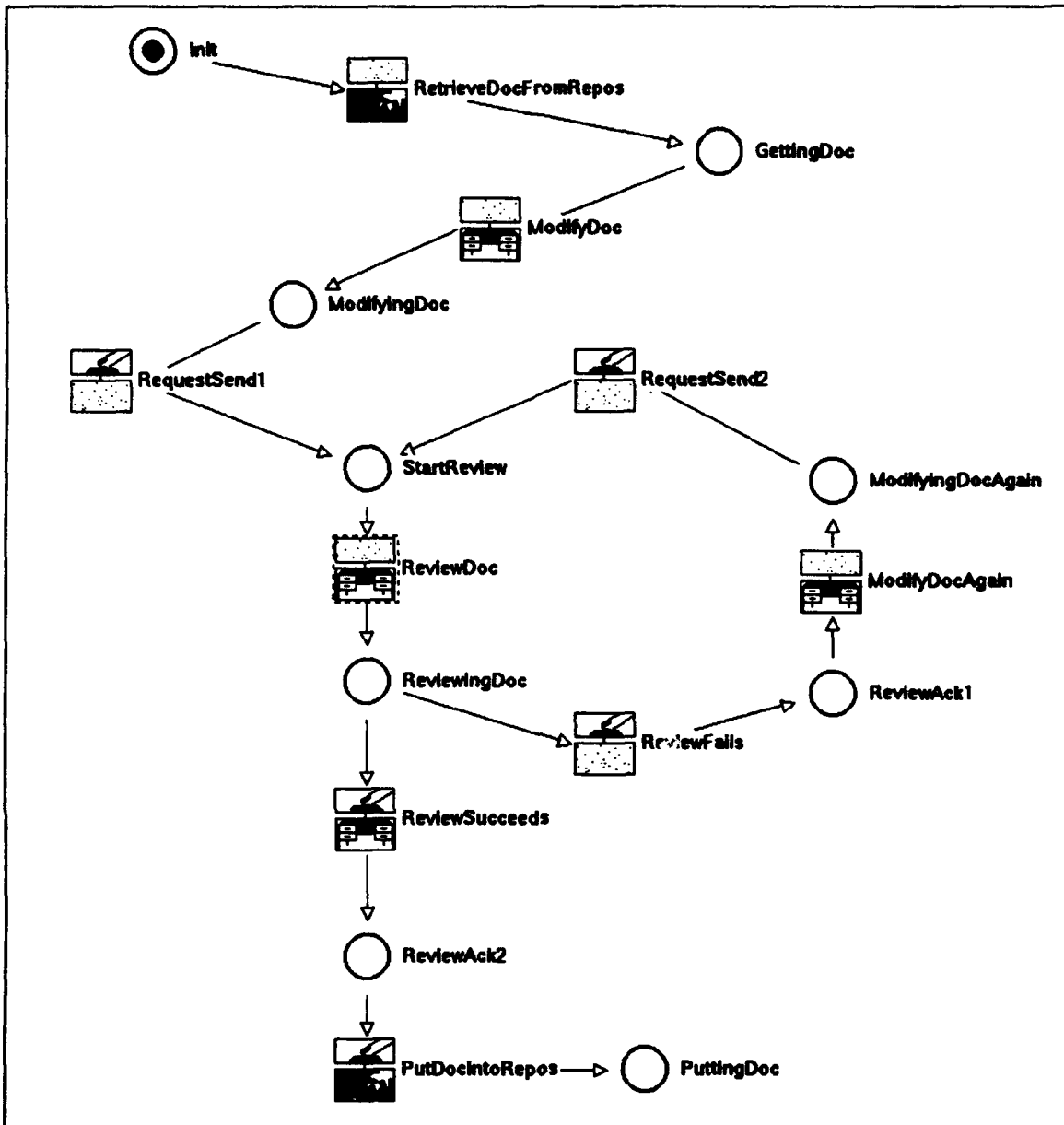

Figure 4-8: Cooperative Procedure for the Activity ReviewIdentify



**Figure 4-9: Cooperative Procedure for the Activity Update**

Unix SCCS commands *get* and *delta* that are embedded in the auxiliary Co-shell functions shown in Figure 4-10. Libraries of such functions can be developed for general process use and are attached to a Cooperative Procedure for use within that Cooperative Procedure.

Notice at the end of Figure 4-8 that the subprocess *Update* (Figure 4-9) is initiated through a procedure call to the action *StartDocMod*. The procedure *EndDocMod* watches for the termination of this subprocess.

```

define sccs_get($path, $file)
    $command=format("cd ", $path, ";", "/usr/ucb/sccs get -e s.", $file,
"sccs.out 2>&1");
    system($command);
end;

define sccs_del($path, $file)
    $command=format("cd ", $path, ";", "/usr/ucb/sccs delta s.", $file,
"sccs.out 2>&1");
    system($command);
end;

```

**Figure 4-10: Co-Shell Library Functions to Retrieve and Save Document Files**

Clearly, the graphical model cannot be expected to define the detailed logic required for enactability. For example, as noted above, calls to SCCS functions have to be made. In other cases, conditions require explicit tests to be performed, and actions may require that assignments of roles to agents be made. These statements are generally made using the Co-shell language windows that can be accessed through the condition and action icons.

### 4.3 The Evaluation

In reviewing the issues to be evaluated, Table 3-3 is the primary focus. Each of the items in categories 1 through 6 of Table 3-3 will be discussed in a separate section below.

#### 4.3.1 Functionality

Category 1 of Table 3-3 is the largest of the six categories, since it is expanded to include an assessment of the capabilities defined in Tables 3-1 and 3-2.

##### 4.3.1.1 Model-Building Capabilities

**Development: Scoping of variables.** ProcessWeaver allows the value of a variable, instantiated in one activity, to be used in activities of children (and their children, etc.). However, variables instantiated at the child level do not have their values propagated up to the parent or higher levels.

**Development: Modeling hierarchies.** ProcessWeaver models activity hierarchies using the Method Editor. While this breakdown describes parent-child relationships between activities as a tree, it does not specify the sequencing of child activities within the parent. This sequencing is specified by the process flow for the parent activity as defined in the Cooperative Procedure. The Cooperative Procedure uses the *Procedure* action (see Section 4.1.5) to initiate sub-activities under it. Because of the scoping problem discussed in the paragraph above, there were significant restrictions imposed on the way the activity hierarchy for the experiment could be constructed. (See also the first paragraph of Section 4.2).

**Development: Supporting model development.** Process models are developed with graphical notations to support high level decomposition of activities (through the Method Editor) and to define the lower level process (through the Cooperative Procedure Editor). Both of these graphical views are supported by textual information that is input through forms linked to the graphical editors. This graphical approach helps productivity by allowing a rapid development of the overall process model. In addition, fewer syntactic and semantic errors are introduced in comparison to a purely textual approach. The graphical form of the model also allows for better communication with persons unfamiliar with process modeling.

**Development: Creating a process library.** ProcessWeaver stores processes in templates and these templates can be reused. Each process is stored in multiple files each of which uses ProcessWeaver's Universal Storage Mechanism. This mechanism uses an ASCII format which aids in porting process from one platform type to another. Different file types are created for Methods, Cooperative Procedures, and Work Contexts. These files are humanly readable and can be manipulated using certain Co-shell functions. However, they are created primarily as means to capture, in textual form, the graphically-defined process models.

**Development: Supporting flexibility of task control.** Humans can be very creative at starting tasks in an opportunistic manner. Thus they may wish to start tasks before all the preconditions for these task have been satisfied (as defined in the process model). For example, a certain task may require the integration of ten software components, and cannot formally begin until all the components are available. However, preliminary integration work can reasonably start when only five of the components have been completed. In this case, one would like to relax the constraint that all components must be available before the task can begin. Allowing for different degrees of constraint on task initiation is thus an important feature which should be incorporated into the process programming language.

Currently, ProcessWeaver does not allow such flexibility in task initiation. When one defines the Petri net associated with a Cooperative Procedure, all tokens must be in the places preceding a transition before that transition can be acted upon. A more flexible approach would be to provide for two types of places: the first type (as now exist) are mandatory, i.e., the transition cannot start without a token being in the place preceding the transition. The second type of place is non-mandatory, i.e., a transition can start without there being a token in the preceding place. While the transition could be initiated without a full compliment of tokens, the transition could not terminate until all tokens are in place.

**Development: Modeling standard programming constructs.** Because of the graphical nature of the process modeling approach, there is a reduced need for conventional programming. This reduction is enhanced by the fact that much information is supplied through fields in standard forms. However, ProcessWeaver does have an expressive textual language called Co-shell with which to describe lower level constructs to support list manipulation, variable assignment and testing, and flow of control. Co-shell programming scripts are most commonly found in the *Prog* actions described in Section 4.1.5.

Besides supporting these standard programming constructs, Co-shell also provides functions to support the manipulation of data and events. ProcessWeaver files conform to an ASCII-based humanly readable format (called the Universal Storage Mechanism) and are used to store the elements of a process. For example, Work Contexts and Cooperative Procedures are stored in USM files. A suite of functions is supplied that allows for the manipulation of these files at a low level. A suite of functions is also supplied to manage events and communication. These allow Co-shell to send and receive messages, allowing components (Unix processes) to communicate through the network. Co-shell can thus, for example, listen for the saving of a specific file and take action when this occurs. Finally, a useful feature of the Co-shell facility is that the shell language can be invoked from a Unix window and can be used to interactively debug Co-shell scripts.

A second method of invoking tools is through direct calls to the Unix operating system using the Co-shell language. This was the approach used in the experiment to invoke the SCCS tools *get* and *delta*, in order to automatically extract and return the document to the configuration management repository (see Figure 4-10).

***Development: Performing parallel aggregated processes.*** There are many situations where multiple, identical subprocesses converge into a single downstream process. An example of this is where several software components are integrated to produce a complete system. To facilitate the development task in such cases, ProcessWeaver allows one to create a default Cooperative Procedure and then load this into multiple parallel activities. Thus, for example, one could load the Cooperative Procedure shown in Figure 4-9 into each of the three parallel activities shown in Figure 4-3.

***Enactment: Assigning agents to roles.*** ProcessWeaver has a very explicit approach to role assignment (or variable assignment in general). In a process template, any process entity (e.g., role, product) can be defined as a variable, to be instantiated when the process starts. Associated with each Cooperative Procedure is a list which specifies the variables needed to run the process. These variables can be instantiated by hand through the procedure parameters list, or, in the case of a child process, the parent process may instantiate them.

***Enactment: Supporting on-the-fly process modification.*** The ability to modify an on-going process may be important, either to adapt to unforeseen circumstances or to improve some procedure (e.g., replacing someone who has left the project, or adding an improved testing tool). Currently there are no mechanisms to allow this.

***Enactment: Logging process data.*** Process data logging is a useful feature for multiple reasons. First, a historical log of process data generated during a debugging run can provide insights into a process model's logical correctness. Second, if a product or process error is made and requires correction, a historic log of the performed process can, in principle, allow this process to be rolled back to an earlier state and restarted. Third, a historic log of a performed process can support process verification, i.e., a post-project analysis can be performed to assure that the process was adequately followed. Finally, process improvement can be supported by process data logs as they allow analysis of the effectiveness of the pro-

cess. ProcessWeaver does not explicitly provide the capability to gather historic data. However, it does provide the underlying functionality for such a capability to be built. It does not, however, provide the capability to perform process roll-back.

**Resource: Invoking tools.** Tools can be invoked in two ways. First, when a tool is invoked through a Work Context icon, it must first be defined in a *weaver.tls* file. A *weaver.tls* file provides a mapping between a tool function and the corresponding specific tool for a specific platform. Thus, when a Work Context calls for a word processor, the *weaver.tls* file can be set up to call FrameMaker for the Sun4. In the experiment, Emacs was invoked to display and edit the text files.

**Resource: Managing Objects.** During software product construction, multiple versions of intermediate and final products will be produced. There is therefore a close tie between process management and product management. (This can be seen in Figure C-2 of Appendix C.) Having the capability to retrieve, store, and test for product versions as an integral capability within the Co-shell language could be useful. As it currently stands, one has to use external version control functions. (SCCS functions were used to support the *Document Update* process).

**Communication: Modeling communication between agents.** Communication between human agents is modeled principally using the Work Context concept. Work Contexts can be used in two ways. First, individual Work Context templates can be instantiated for simple tasks. After selecting the appropriate Work Context from the Agenda, the initiator of the task fills out a Work Context parameters form, in which the task roles are instantiated with the specific entities (e.g., names of people and documents). The appropriate Work Context icon then appears on the initiator's Agenda window and can be dispatched to the appropriate person by dragging the icon over the Delegation icon. Thus ProcessWeaver supports simple task management and communication between team members.

Second, Work Contexts can, of course, be embedded within processes. This has been described at some length above. As with simple task initiation, process initiation requires that roles be instantiated with specific entities prior to process enactment. However, unlike simple task delegation, the initiator of a process does not have to explicitly dispatch Work Contexts to assignees; this is done automatically since the process knows which roles are associated with which tasks, and agents have been associated to roles.

ProcessWeaver can respond to messages broadcast by tools using a protocol which conforms to Hewlett-Packard's Broadcast Message Server. This can be implemented through the *Event* condition (see Section 4.1.5). ProcessWeaver can also access tools that are already available within IBM's WorkBench/6000 (or equivalently Hewlett-Packard's Softbench) using the Co-shell language. This communication is performed by creating a Unix script supported by the ProcessWeaver command *wb\_send*, that allows WorkBench messages to be sent. This form of communication was not investigated in the experiment.

**Communication: Modeling automatic actions.** Automatic actions (i.e., elements of the process that are performed without human intervention) can be easily implemented as was demonstrated in the experiment. The experiment applied this in two areas: requests to end users for decisions and invocation of SCCS tools.

**Debugging: Syntax checking.** Syntax checking is supported both in the Methods Editor and in the Cooperative Procedure Editor. With the Methods Editor, one can check that all the inputs, outputs and roles between activities are consistent. Another type of check is the *Run-Time* check. This check evaluates whether there are inconsistencies between an activity and its related Cooperative Procedure (e.g., it can identify inconsistent parameters).

Supporting the Cooperative Procedures Editor is a syntax checking feature. This graphically highlights any conditions or actions that have faulty syntax statements in attached Co-shell scripts. If one has a condition or action box open, this option will also highlight the offending line of Co-shell script.

Co-shell scripts can be interactively debugged off-line by typing *coshell* in any Unix window. This provides a vehicle for debugging routines such as shown in Figure 4-10.

**Debugging: Tracing process dynamics.** One can graphically view an executing process by selecting the *View* button located in the Cooperative Procedures main menu. In this mode, the Petri net tokens can be observed to move from place to place as the process evolves, thus providing good insight into behavior characteristics of the process. Ongoing processes can always be viewed with the *View* feature, so it also provides a window into the real-time status of project tasks.

**Debugging: Querying.** At any point in the process, the *interact* option allows the user to implement Co-shell commands thus, for example, allowing values of variables to be examined.

**Debugging: Spying.** While one cannot spy on the variables of the process, ProcessWeaver is supported by a simple spy function that provides information on the messages that are broadcast on the communication channel (e.g., for event notification and reply).

**Debugging: Reachability, deadlock, logging of process data.** These are not explicitly supported in the reviewed version of ProcessWeaver.

#### **4.3.1.2 End-User Functional Capabilities**

**Scheduling periodic work.** ProcessWeaver has the ability to initiate periodic Work Contexts. The period can be set, for example, so that the Work Context for a task appears on a particular day of the week or on a particular date in the month.

**Collecting metric data.** ProcessWeaver has no explicit mechanisms for collecting metric data. Events can, however, be recorded using the event handler functions of the Co-shell language. These mechanisms could be used to construct a metric gathering capability.

**Supporting project management tasks.** ProcessWeaver provides the capability to communicate with project management tools through a supplied Cooperative Procedure that starts up a project. This can invoke either MicroSoft Project for Windows or Project Management Workbench 3.1 under PC/DOS.

**Supporting the individual user.** ProcessWeaver (V1.2) is primarily designed to support processes management, and, other than scheduling periodic Work Contexts, does not support, for example, "to do" lists or the tracking personal tasks.

**Supporting group communications.** ProcessWeaver provides effective communication through the Work Context feature. This feature can be used to initiate and delegate individual tasks (or just send messages) and is also the communication mechanism used when tasks are embedded within processes.

### 4.3.2 Developer Issues

**Ease of learning.** The graphical nature of ProcessWeaver is a considerable help to developing processes. ProcessWeaver allows the major activities to be defined through a work-break-down type of diagram, with each activity having its own process defined through a Cooperative Procedure (Petri net diagram). This is intuitively appealing and helps with learning. The novice user may however find the connection between all the diagrams and associated text boxes somewhat confusing at first, although this decreases as the user gains experience with the system. The graphical component of ProcessWeaver is supported by the textual Co-shell language. This provides lower-level constructs that are difficult to describe graphically. Use of simple Co-shell scripts was made in the experiment and little difficulty was experienced.

**Ease of use.** Once ProcessWeaver's organization is understood, one can develop process models quite rapidly. The graphical approach to model development is fun, easy to use, and less likely to promote errors than a textual approach. A generic Cooperative Procedure (that may be user-defined) can be generated for each activity specified through the Method Editor, and this is useful for developing and debugging prototypes of the model. However, experience gained during this investigation indicates that Cooperative Procedures will most likely need customizing.

The window that displays Cooperative Procedures works well for small process models, like those discussed in this report. However, ProcessWeaver does not currently have the ability to zoom in and out of a diagram and scrolling across and down the window is quite slow. These implementation details are likely to cause some frustrations when larger models are constructed.

**Effectiveness of support for development.** ProcessWeaver's graphical approach to process definition significantly simplifies and speeds up model-building. The Method Editor provides a range of options with which to construct and edit activity hierarchies; the Cooperative Procedure editor allows process elements to be rapidly accessed, linked, and rearranged, while the Work Context editor provides a very straightforward means of creating the end-user

interface. Navigating between the editor windows and other supporting windows was found to be very easy, once the relationships between the elements was understood. In addition, support for model debugging (to be described later) was found to be quite comprehensive.

Because each Method, Cooperative Procedure, and Work Context is stored in a separate text file, the number of files associated with a complete process model can become quite large. (There were 15 files for the simple example model.) Thus file management and version control could become an issue. Transmitting all the files for the example model was found to be somewhat tedious.

**Quality of on-line help.** On-line help is not implemented in the version (1.2) of Process Weaver that was used.

**Error handling.** ProcessWeaver provides a variety of high-level process-oriented error messages. For example, if one attempts to generate a default Cooperative Procedure for an activity before any inputs, outputs, or roles have been defined, the message *Activity "XXX" has not been edited yet => no inputs/outputs/roles* appears. In some cases, errors cannot occur as syntax checking prevents illegal states. For example, in constructing a Cooperative Procedure, the system prevents the linking of two contiguous transitions or places.

### 4.3.3 End-User Issues

**Ease of learning.** There is a spectrum of end users from those who simply respond to Work Contexts sent (from an ongoing automated process), to those who develop Work Contexts in order to communicate requests, and to those who develop simple Cooperative Procedures to automate short processes. Each of these end-user categories requires different levels of expertise. Technical learning for the first group is likely to be minimal, although significant behavioral adjustments will be needed for such people. In the second category, development of Work Contexts can help an individual in scheduling periodic tasks such as writing end-of-the-month reports, as well as for interaction between individuals. Such development requires knowledge of a limited subset of ProcessWeaver's functionality (making and instantiating a Work Context template), so learning should be straightforward. The third category of end user will require a lengthier period of training, as knowledge of a significant fraction of ProcessWeaver's capabilities will be required.

The current ProcessWeaver manual does not address end-user categories, or how ProcessWeaver should be implemented by an end user. Having some guidance in this area (perhaps through an end-user manual) would thus be of considerable help. End-user learning in the broader sense must also address technology adoption issues, since a PCF such as ProcessWeaver can potentially have a dramatic impact on the way people work. Teaching personnel to work within a process that is driven by automation will be a greater challenge than simply training these personnel on these technical issues.

**Ease of use.** ProcessWeaver provides a standard Work Context format for presenting information related to one task to the end user. This format allows for:

- the display of textual information that explains what the task involves,
- document icons that allow access to the documents themselves, and
- control buttons, that allow for decision making such as indicating that the task has been completed (see Figure 4-2 as an example).

This format was found to be intuitive and easy to use. For some more complex applications it might be useful to have the functionality provided by pull-down menus, but this is not currently provided.

**Clarity of presentation.** As indicated in *ease of use*, the format of basic Work Context windows through which information is presented is well designed. ProcessWeaver cannot of course be responsible for process models that have poor explanatory text, inappropriate icons, or badly chosen controls.

#### 4.3.4 Performance

**Execution time efficiency.** With respect to response times, there were no long delays experienced. The following times are for the experimental model that was implemented on a Sun 4 SPARC station running under Sun OS 4.1.2. For the end user, loading a new cooperative procedure took about one second, while after the roles had been instantiated with agents, it took about eight seconds for the first Work Context icon to appear in the Agenda window. Transmitting a Work Context from one user to another took about four seconds. Delay times associated with developing process models were also modest. Opening the method window took about a second, opening a Cooperative Procedure window took about five seconds, while opening a Work Context window took about three seconds. These times are approximate, as a regular watch was used, and there was some minor variability in the times resulting from different machine loadings. Note that the process used model was small, and the results do not indicate how response times will vary with model size, nor is it known how response times will vary with larger numbers of users.

**Space efficiency.** The ProcessWeaver files take about 13.5Mb of memory (in the *bin* directory). User files for the process example took up about 15.8 Kb, half of this being for the Work Contexts. Additional memory is taken up by each instantiated (run-time) process model. For the experiment, each instance took up about 8Kb. Since these can accumulate, they can take up an increasing amount of space if they are not managed. They are deleted if the process successfully terminates.

#### 4.3.5 System Interface

**Ease of tool integration.** As discussed above, tool integration was implemented:

- using the *weaver.tls* file that associates a tool class with specific tools on specific platforms, and
- making Unix calls through Co-shell scripts.

Both approaches were found to work with few problems. These interfaces are relatively simple and essentially allow one to start and stop tools.

**Portability.** ProcessWeaver runs on Unix platforms from Hewlett Packard, DEC, and Sun that support X-windows, X11R4, Motif, NSF 4.0. The Agenda can also be run on PCs running Microsoft Windows 3.1.

The process model files are all defined using ProcessWeaver's Universal Storage Mechanism which is based ASCII-based. They are therefore portable between machines.

**Interface to the operating system.** Bourne shell commands can be embedded in Co-shell scripts through the Co-shell *system* function. Using this mechanism, file read-write access and the SCCS calls were implemented. Within ProcessWeaver, only files owned by ProcessWeaver can have their access permissions changed. This constraint is more a consequence of the Unix system design than of ProcessWeaver design. In a large project, such files would all have to be owned by the "process" rather than appropriate individuals, and this might have restrictive consequences.

#### 4.3.6 Off-line User Support

**Support from Customer Representatives.** ProcessWeaver does not yet have a large support staff in the US, although Cap Gemini is planning to expand this function. However the support that was provided for the work associated with this report was both responsive and technically knowledgeable.

**Clarity of Documentation.** The current manuals (User and Reference) [ProcessWeaver 92] are good for reference but not as tutorials. The User's Manual does an effective job of explaining many of the low level details. However, it is weak on providing the broad picture, i.e., explaining how all the functional elements of a process model are linked together. The User's Manual could also be improved if it provided examples of use, such as leading a model developer through the process of model construction, including the use of the Co-shell. In the Reference Manual, code fragments illustrating the use of Co-shell functions are provided with the function definitions and these are necessary but not sufficient. A set of functions is provided to manipulate the ProcessWeaver data files, but little explanation is provided on why these functions are needed or how they are used. Finally, if the user wishes to use the event-driven features of ProcessWeaver, he/she must have a working knowledge of this subject — again little more than a listing of the functions is provided. Thus, a separate tutorial manual covering model construction, use of the Co-shell language and its event-driven features, etc., would be of great value and would make ProcessWeaver more accessible to potential users. As mentioned earlier, a separate manual covering both end-user applications and automated process adoption issues would also strengthen the product.

The ProcessWeaver manuals are logically organized and in general information can be found rapidly. The indexes for both manuals are good, but could be more complete. For example, none of the terms associated with "viewing" a running cooperative procedure (see *Debugging:*

*Tracing of process dynamics*) such as *view*, *kill*, *stop*, and *sleep* are in the User's Manual index.

**Availability of Hands-On Training.** Currently training sessions are limited by the small number of support personnel in the US. However, Cap Gemini intends to expand this area as it does with customer support.

**Availability of Encoded Process Examples.** To date there are few available encoded examples. The version supplied (1.2) came with one working demonstration. A variety of enactable examples of varying size and application would be of great benefit, not only for learning the system, but also as a foundation for customized applications.

#### **4.4 Improvements in Functionality**

ProcessWeaver Version 1.2 was reviewed in this report. However, this version is soon to be superseded by Version 2. Some of the significant updates, which relate to the preceding discussions, are summarized below. Note that, at the time of writing, the author has no hands-on experience with this new version. It is anticipated that the new version will be made available for general release at the end of June 1994.

Version 2 is expected to include, but not be limited to, the following:

- Links will allow integration with Hewlett-Packard's Broadcast Message Server (or equivalently IBM's WorkBench 3.0) and with the IBM implementation of PCTE.
- A change will be made in the scoping rules to remove the restrictive scoping problem discussed in Section 4.2.
- A tutorial manual with large example and "how-to" section will be included with the documentation. Also, user documentation will be available as on-line context-sensitive help.
- Folders will be provided for organizing Work Contexts.
- Through selection lists, an event can be generated without terminating a Work Context, as is required in Version 1.2.
- A set of application tools covering configuration management, software testing and test tracking, and general office automation will be available.
- An Activity Instance Manager (AIM) will be added. This will provide project management with functions for planning, process tracking, and graphical browsing of the process model. It is anticipated that the feature will remove the need for use of external project management tools.

By adding the end-user application capabilities described in the last two items, ProcessWeaver is no longer a framework but takes on some of the characteristics of an environment. Thus, like SynerVision, ProcessWeaver, Version 2, may be called a process-centered environment (PCE).

## 5 The Synervision Experiment

As in the previous section on ProcessWeaver review, this section starts out with a review of SynerVision's approach to process automation. The subsequent sections then deal with SynerVision in the context of the evaluation experiment.

### 5.1 Review of SynerVision

SynerVision provides four "use-models" that address increasingly broad measures of process support. These use-models cover:

- management of personal tasks,
- management of group tasks,
- process enactment through the use of process template,
- process-centered environments.<sup>6</sup>

In the management of personal tasks, personal task hierarchies can be created, and attributes associated with these tasks can be attached. Such attributes may be associated, for example, with management of time or with dependencies between tasks. In this way the owner of these tasks can track and monitor their status. In addition to these personal functions, the use-model for group tasks contains functionality to support group interactions. Thus tasks can be delegated, and broader use is made of attributes to support project management such as task status and time spent on tasks. More formal support is provided through the process-enactment use-model. At this level, processes (i.e., task hierarchies and their behavior) are captured in templates that can be reused. These templates support facilities for communication, tool invocation, metrics collection, etc., and provide the "glue" that embeds these facilities in user-defined processes. Process-centered environments (the final use-model) apply the concepts of the three previous use-models to implement major process enactment applications, and Hewlett Packard foresees that commercial vendors will be mainly responsible for their development. Once developed, process-centered environments will be customized to meet the needs of individual organizations. To date, the only significant process-centered environment built on the SynerVision framework is HP's ChangeVision, a product for managing change request tracking and software updating.

Given the discussion of Section 2.2, a possible relationship between SynerVision's use-models and the levels of the Capability Maturity Model can be seen to exist. At CMM Level 1 SynerVision's first two use-models can be effectively adopted, since neither use-model needs to have strong notions of defined process. At these levels, individuals can be helped in the informal management of personal tasks, and modest group communications are supported. It

---

<sup>6</sup> By an unfortunate coincidence, SynerVision's name for their last use-model (process-centered environments) is the same one as used in a more general context within this report. (See Appendix D for the report's definition). However, the term *process-centered environment* is only used with SynerVision's meaning in Section 5, and it is made clear when referred to in this sense.

should be noted, however, that use of these models is an effective precursor to having processes defined, in that identification of tasks and gathering of simple task metrics are encouraged. In the third use-model, enactable processes are defined, and this encourages CMM Level 2 behaviors. Having the processes automated prevents groups from sliding back into informal, ad-hoc practices. The final use-model (process-centered environments) envisages ambitious use of process automation, with defined processes being adopted throughout an organization. To the extent that such process models are accepted consistently by multiple groups within an organization, this use-model may support CMM Level 3 behaviors.

### 5.1.1 Managing Personal Tasks

The variety of functions that SynerVision provides for the management of personal projects, are briefly reviewed below. Central to task management is the notion of the task and task hierarchies. Figure 5-1 shows the main SynerVision window in which a simple task breakdown

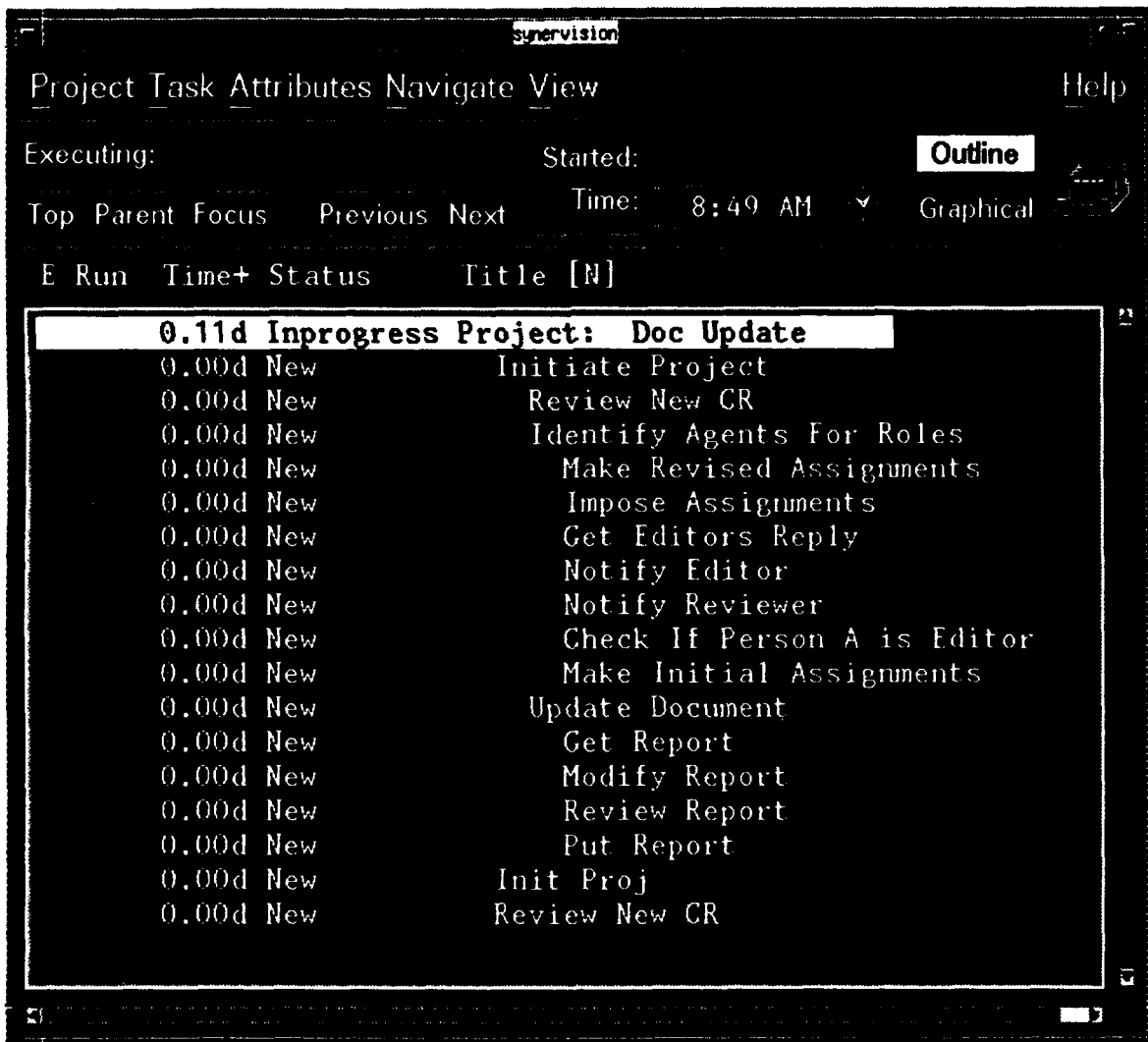

Figure 5-1: SynerVision Main Window Illustrating a Task Hierarchy

structure is illustrated. Note the task information columns to the left of the tasks themselves. This information can be customized, and a variety of display options such as *earliest start date* can be included in these columns.

Lists of current tasks, such as shown in Figure 5-1, can be developed for individual use. When a task is executing (i.e., it is highlighted and has an "E" in the cell of the column marked with an "E"), time is allocated against it. The times spent on higher-level tasks reflect the durations spent in child tasks. This time-recording mechanism provides support for such activities as managing monthly objectives and distributing time between projects. One can also filter tasks according to the task's attributes using such attributes as task status or priority. For example, one can suppress all the tasks that have the status *Inprogress* from the task structure shown in Figure 5-1. In a similar way, one can also sort tasks according to task attributes such as status or priority.

SynerVision provides a set of windows through which one can customize the attributes of tasks to be performed. The first of these windows is the *Basic* window. This window allows the user to input information such as task priority, earliest start time, and estimated task duration. The window also displays how much time has been spent to date on a task. The second window (*Notes*) allows one to attach one or multiple textual notes to a task. This can be useful for recording either what should be performed in this task or information on how the task was performed. The *Dependency* window then allows one to set constraints on the sequence through which the tasks are performed. Thus one can state that task B should be started before task A is completed and whether this constraint is only advisory or whether it is mandatory. To support automation inside a task, SynerVision has the capability to attach action scripts through the *Actions* window. These scripts are written in the language of the Unix Bourne shell with SynerVision extensions and can thus support a wide range of functionality. As a minimum, one can call on utilities such as for e-mail or word processing, but more complex requests can be made through this feature.

A major advantage of automating the software process is that metrics can be collected relatively accurately and painlessly (as compared to manual approaches). Because SynerVision contains or generates information related to tracking project progress, it can provide the user with a variety of standard and customized reports that are useful to track both individual and project efforts. These data are useful, not only to control an ongoing project, but for subsequent process improvement. Standard process reports include:

- Estimation accuracy (planned vs. actual times)
- Hierarchical results (copy of the task information shown in Figure 5-1)
- Planned vs. unplanned tasks
- Process adherence by user
- To do list
- Total tasks by project
- Total tasks by user

Standard project reports include:

- Blocked tasks
- Completed tasks
- Project completion
- Project time
- Quality status
- Task time

### 5.1.2 Managing Group Tasks

The major extension that the group feature provides is the ability of group members to communicate about tasks. The project leader can set up a task (with a sub-task structure) and can define which members of the group have access privileges to each task. Tasks in a task hierarchy can only have one assigned owner, and sub-tasks can be created by individuals who have been assigned a higher-level task, and, during project execution, individuals can accept, reject, or delegate tasks. This team-oriented task structure and related task status information can be viewed by members of the project. However, read permissions are attached to all tasks to control visibility of task information, and write permissions are attached to control execution/modification privileges.

In order to set access permissions on a task, the original owner of the task uses the *Access* window shown in Figure 5-2. This window allows control of who has read and write permissions for that task. It also allows for the forwarding of the task to the person identified under the *NewOwner* column. Upon receiving notice of the task (the in-box shown in the upper right of Figure 5-1 becomes full), the new owner can open the *task in-box* shown in Figure 5-3 and has the option of accepting, reassigning, or rejecting the task.

### 5.1.3 Process Enactment Through the Use of Templates

Within SynerVision, there is an incremental growth of concepts from personal processes to group processes and then to process enactment through the use of process templates. Processes that have been developed for personal or group support can be automatically captured in templates and reused. Thus personal and group processes can be modified and improved upon and, when they are considered effective, can be transformed into templates for adoption by similar groups. In this way, there is less likely to be a major cultural impact, since they have not been imposed from outside, but were evolved within the organization's culture [Kellner 93a].

When a template is automatically generated from a personal or group process, a text-based script is generated and stored in a file. This file is humanly readable since the process description is compiled into a script that is based on the Unix Bourne shell language [Sobell 89] with extensions to account for process needs. Alternately, partial scripts can be automatically generated from a task hierarchy and then completed by hand, or they can be fully written by hand.

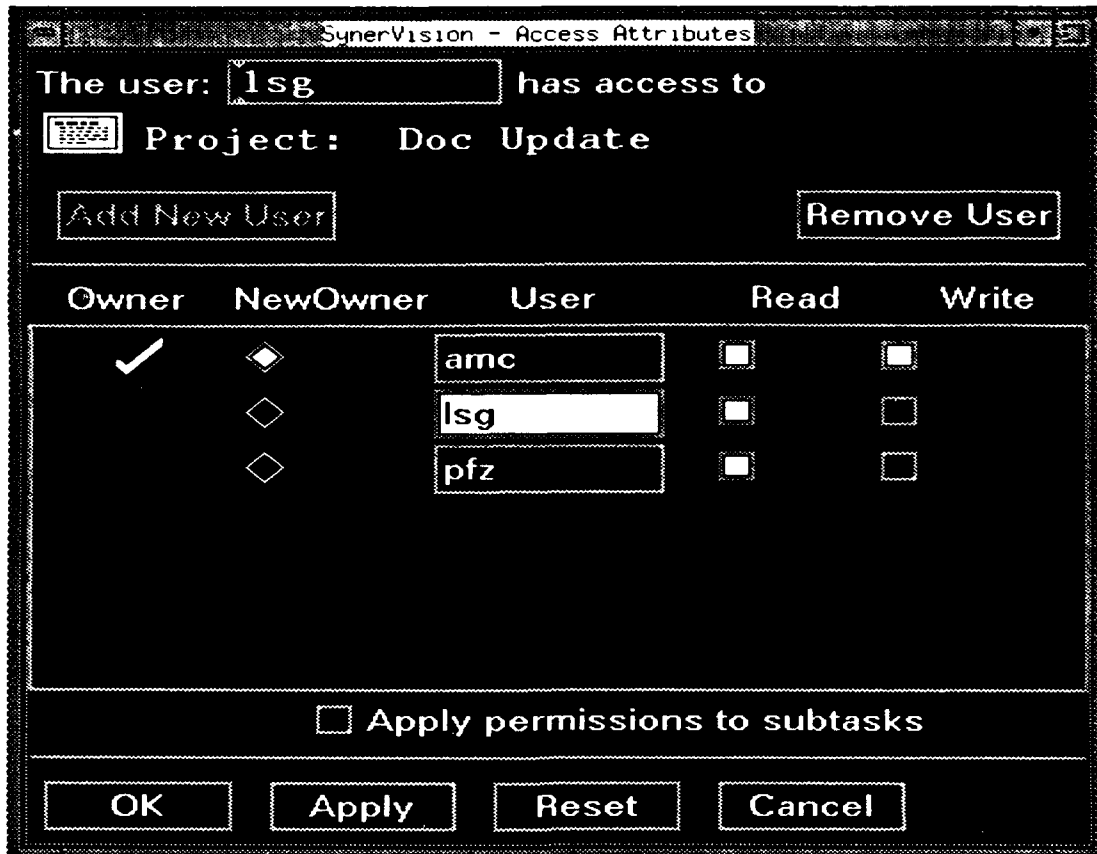

Figure 5-2: SynerVision Access Attributes Window

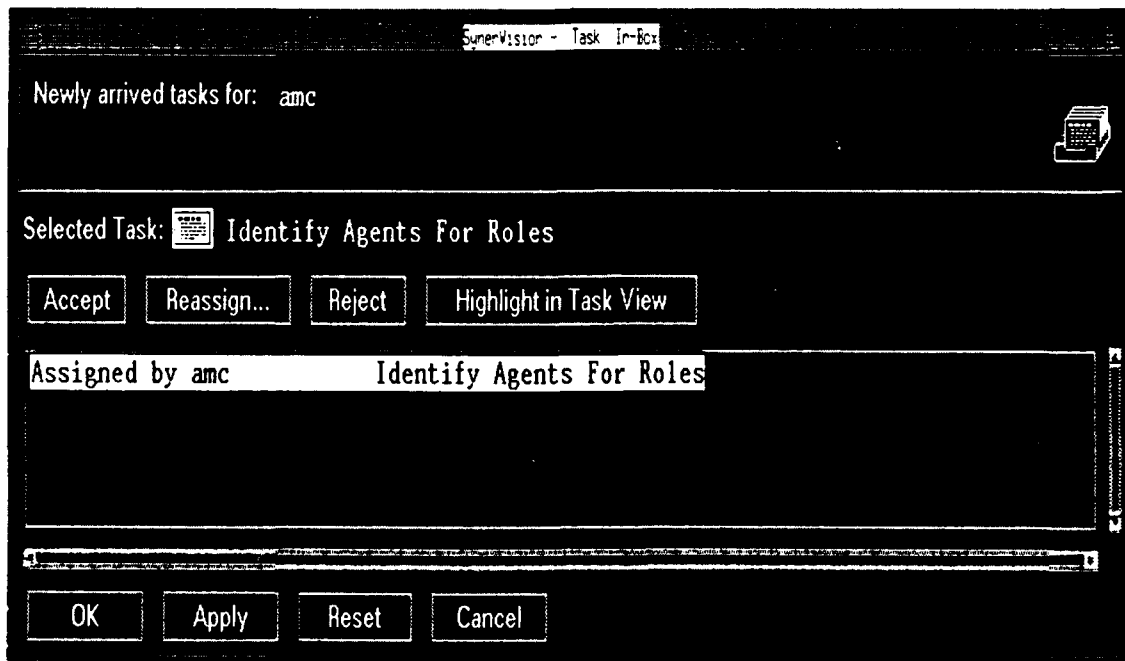
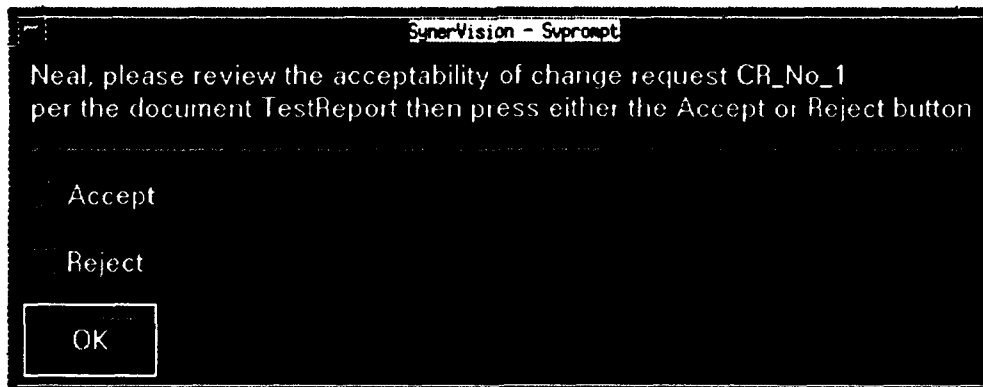

Figure 5-3: SynerVision Task In-Box Window

The template language (as an extension of the Bourne shell language) provides features that are not available in automatically generated scripts. In this context, one of the more important additions to the process-template use-model is the `AUTOMATIC_ACTION` function. Section 5.1.1 discussed the *Actions* window, a window in which commands can be placed to invoke actions. If such actions are compiled into a template, they are embedded in what are called `MANUAL_ACTIONS` and, to be initiated during process enactment, require human intervention. On the other hand, `AUTOMATIC_ACTIONS` can be initiated by the machine, with no human intervention. However, they cannot currently be generated from the *Actions* window and must be written into the script. An overview of this scripting language will be given in Section 5.2.

One does not need to follow a process script from beginning to end. For example, one can start at a task in the middle of a process script, provided that the preconditions are consistent with that task and its children. However, doing so may be contrary to the project's policies. Thus SynerVision provides a function *Process Adherence*, that analyzes that tasks have actually been performed. This information is also useful from a metrics analysis point of view.

Figure 5-3 shows the standard communication dialog window. However, this does not always provide sufficient functionality. For example, it does not allow text to be entered into the system. Thus SynerVision provides a Bourne shell-based function *svprompt* with which allows custom dialog windows can be designed. These dialog windows allow for buttons, text display, and input. One such window is shown in Figure 5-4. This type of dialog window is used exten-



**Figure 5-4: Dialog Window Generated Through the *svprompt* Command**

sively in the process example, and is the equivalent of ProcessWeaver's Work Context window.

#### 5.1.4 Process-Centered Environments

The final use-model is called the *process-centered environment* (HP's term). This use-model provides little in the way of technical extensions to the previous use-models, but focuses mainly on tailoring existing large-scale process templates for specific applications. Hewlett-Packard envisions that these large models are likely to be developed commercially and cite their Chan-

geVision as an example of such a case. Customizing existing process models is seen as requiring much less investment of effort than having to develop the processes from scratch. Precedents for this exist, for example with building one's own CM system or word processor. Often these systems come with features that make them user-tailorable.

## 5.2 Developing the Synervision Process Model

In this section we will discuss the development of the enactable SynerVision process scripts from the process graphs shown in Figures 3-2, 3-3, and 3-4. For a complete understanding of these scripts, a knowledge of the Bourne shell scripting language is useful but not essential for the following discussion. Appendix B provides a full listing of the complete enactable script that was developed for the experiments, and for illustrative purposes, Figure 5-4 shows a short, simplified, but executable, version of the Appendix B script. This script implements the top-level task (Figure 3-2) breakdown, but does not expand the lower-level tasks *Review New CR* and *Identify Agents for Roles*.

The top-level task has three sub-tasks or children, and associated with each of these is an action defined by the associated `AUTOMATIC_ACTION` statement. The task breakdown structure can be created manually by simply typing in the text, or it can be generated automatically using the facilities provided by the main SynerVision window. In either case, the associated `AUTOMATIC_ACTIONS` have to be generated manually.<sup>7</sup> Some comments on this script are appropriate.

A task can be automatically activated when the value of either the *executing* or *status* attribute of that task is changed. For example, at the end of the first `AUTOMATIC_ACTION` in Figure 5-5, the `ATTRIB` function sets the *Executing* condition of the task *RevNewCR* to *Running\_Foreground* (see line 1). The second `AUTOMATIC_ACTION` is fired when status of its associated task (*RevNewCR*) changes from *New* to *InProgress* (see line 2). Since *RevNewCR*'s initial state is *New* and *Running\_Foreground* implies a status of *InProgress*, the activity *RevNewCR* is activated automatically at the end of the *InitProj* activity. Similar state transitions can be followed for the other tasks. Thus each task may activate and deactivate other tasks through the `ATTRIB -i -v -t $task...` command. This does not, however, prevent one from starting a task in the middle of a process sequence; one is free to start anywhere, although errors may occur if, for example, the preconditions for that task are incorrect. In order to force a task to complete before another one begins, the `DEPENDENCY` function (not used in the example) may be applied.

## 5.3 The Evaluation

As with *ProcessWeaver*, the six categories of Table 3-3 and the items within these categories provide the basis for the review of SynerVision.

---

<sup>7</sup>. Some automation of this is currently possible, and it is anticipated that future versions of SynerVision will be able to accommodate both `MANUAL_ACTIONS` and `AUTOMATIC_ACTIONS`.

```

#####
# identify task structure (main task and child tasks) #
#####

TASK 'Initiate Project'
InitProj=$last_TASKID

CHILDREN_BEGIN

    TASK 'Review New CR'
    RevNewCR=$last_TASKID

    TASK 'Identify Agents For Roles'
    IdenAgForRl=$last_TASKID

    TASK 'Update Document'
    UpdateDoc=$last_TASKID

CHILDREN_END

#####
# Define AUTOMATIC_ACTIONS associated with tasks #
#####

# Initialize variables
AUTOMATIC_ACTION -t $InitProj Status New Inprogress perform <<EOF
    ATTRIB -i -v manager "Paul"
    ATTRIB -i -v report "War and Peace"
    ATTRIB -i -v CR "Change Title"
    ATTRIB -i -v -t $RevNewCR "Executing=Running_Foreground" ### line 1 ###
EOF

#send message to manager identifying document to be reviewed
AUTOMATIC_ACTION -t $RevNewCR Status New Inprogress perform <<EOF ### line 2 ###
    CR='\GET_ATTRIB CR\'
    report='\GET_ATTRIB report\'
    manager='\GET_ATTRIB manager\'
    result='\svprompt -p \"$manager, please review change request \${CR}
for document \${report} and identify whether to accept or reject.\" -L -d "accept
reject\'
# mark this task completed
    ATTRIB -i -v -t $RevNewCR "Status=Completed"
    if [ \${result} = "accept" ]; then
# start the next task
        ATTRIB -i -v -t $IdenAgForRl "Executing=Running_Foreground"
    else
# mark parent task as abandoned
        ATTRIB -i -v -t $InitProj "Status=Abandoned"
    fi
EOF

AUTOMATIC_ACTION -t $IdenAgForRl Status New Inprogress perform <<EOF
    svprompt -p "Now performing Identify Agents For Roles"
    ATTRIB -i -v -t $UpdateDoc "Executing=Running_Foreground"
    ATTRIB -i -v -t $IdenAgForRl "Status=Completed"
EOF

AUTOMATIC_ACTION -t $UpdateDoc Status New Inprogress perform <<EOF
    svprompt -p "Now performing Update Document"
    ATTRIB -i -v -t $UpdateDoc "Status=Completed"
EOF

```

Figure 5-5: Example of a Short SynerVision Script

### 5.3.1 Functionality

Category 1 of Table 3-3 (functionality) is the largest category, since it is expanded to include assessments of the capabilities defined in Tables 3-1 (Model-Development Capabilities) and 3-2 (End-User Capabilities).

#### 5.3.1.1 Model-Development Capabilities

Item 1a of Table 3-3 addresses "completeness of major functional areas for development, as identified in Table 3-1". This subsection thus reviews the items of Table 3-1.

**Development: Scoping of variables:** SynerVision allows variable values, defined anywhere in the process hierarchy to be used anywhere else. However, visibility of the variable's value in the hierarchy is controlled using the ATTRIB function.

**Development: Modeling hierarchies.** SynerVision models task hierarchies through a textual task breakdown structure. An example of such a structure is shown in Figure 5-1. Also provided in this view are columns of user-customizable information on the tasks, such as time spent on the task. One can also illustrate this task structure graphically. However, the textual form provides a more compact and useful view of the task information than the graphical form.

**Development: Supporting model development.** As discussed in Section 5.1.3, SynerVision processes can be developed incrementally, from personal processes to group processes to formal process templates. All of this can be performed with little or no programming. In this lies a real strength. However, if one has to develop processes with any complexity, templates are likely to require significant hand-coding. This requires a knowledge of the Bourne shell language, and in this there are two drawbacks. First, development time can be lengthy and error prone. As discussed in the following subsection, SynerVision currently has few debugging aids to support development. Second, it is likely to be difficult to communicate the resulting process descriptions, using the templates, to the people who have either to use the processes, or to sign off on their acceptability. In this regard, a front-end graphical interface for process definition would be very helpful

**Development: Creating a process library.** One can build SynerVision process templates for library creation in two ways. In the first approach, the menu items in the window interface (see Figure 5-1) provide the functionality necessary to define logically simple processes. The *Generate Template* feature can then be used to automatically generate a permanent template script for that process. In the second approach, the template script is written by hand. Of course, an automatically generated script can subsequently be modified or expanded by hand.

**Development: Supporting flexibility of task control.** SynerVision allows the end user of a process to start intermediate tasks at any time. For example, one may wish to start writing code, even although the formal code design has not yet officially been signed off. In this case, it is the user's responsibility to make sure that the inputs to the task are correct. However, SynerVision also provides the means to control task initiation, if necessary, through the

DEPENDENCY function. In addition, a task attribute *dependency-enforcement* can be used to specify whether this dependency is mandatory or can be overridden. Dependencies can also be used to implement AND and XOR relationships between tasks. This flexibility of task control in SynerVision reflects a practical understanding of real-world user issues.

**Development: Modeling standard programming constructs.** Since the SynerVision template language is based on the Bourne shell scripting language, it has all the standard programming constructs that the shell contains, i.e., looping, conditionals, variable binding, etc.

**Development: Performing parallel aggregated processes.** For a discussion of this topic, see *Performing parallel aggregated tasks* in Section 4.3.1.1. SynerVision does not include any explicit capability in this area. If one wishes to have identical processes performed in parallel, one would have to program this into the script by hand, either by placing the common process in a shell function which is called multiple times, or by duplicating the appropriate segment of script for the common process.

**Enactment: Assigning agents to roles.** There is no explicit concept of "role" within SynerVision (other than the system administrator function) and thus there are no mechanisms for assigning agents to roles. Specific individuals are assigned read/write access to tasks and documents, depending on what their responsibilities are. One must explicitly program into a template the role mechanism, as is done in the experiment template (see the first AUTOMATIC\_ACTION in Appendix B).

**Enactment: Supporting on-the-fly process modification.** From practical considerations, there may be times when modification of a process that is currently being enacted is required. For example, a task performed late in a process may have to use a product different from that specified at the start of the process.<sup>8</sup> In SynerVision, a process is guided by executing its pre-defined process script. The script cannot be changed during this execution and thus adapting processes on-the-fly is not allowed. In the above example, this means that once the product has been specified, it cannot be replaced by another, unless the possibility for this change has been accounted for in the process script.

**Enactment: Logging process data.** For a discussion of this topic, see *Logging process data* in Section 4.3.1.1. SynerVision provides a feature called Process Adherence through which reports of tasks actually performed can be generated. Additional data logging capability could be incorporated into a SynerVision script by saving information about tasks performed to a file. In theory, process roll-back could be implemented if appropriate process and product data were logged. However, considerable thought would have to be given to its implementation, particularly with respect tracking back through product versions — and SynerVision does not provide any explicit capability to manage product versions. (See *Managing Objects* below.)

---

<sup>8</sup> However, if such modifications are allowed, they must be very carefully planned, or there could be serious side effects on the execution of the rest of the process.

**Resource: Invoking tools.** Tools can be invoked in the template language through Bourne shell calls. This approach provides the simple ability to start and stop a tool, and was used in the experiment (see Appendix B). HP's Broadcast Message Server can be used to provide greater encapsulation functionality, but is not used here.

**Resource: Managing Objects.** For a discussion of this topic, see *Managing Objects* in Section 4.3.1.1. SynerVision process scripts are based on the Bourne Shell language and as such have full access to all the Shell's commands, including the SCCS version management functions. There is, however, no explicit support for version control at the process management level.

**Communication: Modeling communication between agents.** Communications can be performed in several ways:

- Tasks can be assigned from one person to another using the Access Attributes window (Figure 5-2). Such assigned tasks appear in the receivers Task In-Box (Figure 5-3). Tasks assigned automatically (using the ATTRIB function in a process template) can also appear in the Task In-Box window.
- Communications between human agents or from the machine to a human agent is supported inside scripts using the *svprompt* function. *svprompt* generates a customized dialog box that provides optionally for textual messages, a text input field, and buttons.
- Communications can also be established through a connection to SoftBench's Broadcast Message Server. Since this is not an explicit part of SynerVision's functionality, it is not used here.

**Communication: Modeling automatic actions.** If a task needs to initiate an automatic action, or a sequence of actions,(i.e., actions without human intervention), the function AUTOMATIC\_ACTION is used. This was discussed in Section 5.2

**Debugging: Syntax checking.** SynerVision provides error information when a model is instantiated and also at run-time. Since the template language is an extension of the Bourne shell, one can interactively debug expressions or redirect values of variables.

**Debugging: Tracing process dynamics.** Tracing of the real-time status of tasks can be performed by viewing the *status* column of the SynerVision Main window (see Figure 5-1). As a process evolves the status of tasks change and provide a limited indication of what is happening. During the execution of a process, this feature also allows participants in the process to view task status. However, this trace feature is fairly limited as an aid for debugging.

**Debugging: Logging process data.** Selected process data can be logged to a file during process execution through manually inserted statements in the process script.

**Debugging: Reachability, deadlock, querying, spying.** SynerVision does not support these functions.

### 5.3.1.2 End-User Functional Capabilities

**Scheduling periodic work.** The ability to automatically schedule periodic tasks such as weekly meetings can be very useful. However, SynerVision does not explicitly provide this capability (at least not without writing some Bourne shell script). This is an example of where some built-in higher-level functionality could improve end-user effectiveness.

**Collecting metric data.** One of the advantages of adopting a PCE is its potential for gathering accurate and complete metric data automatically, thus relieving the end-user of a distasteful chore. SynerVision provides very effective support for the collection and review of time- and task-related metric data. For example, it will track actual-to-estimated task times, and percentage of tasks complete.

**Supporting project management tasks.** Project management is supported through the metric data described above. Thus a project manager can maintain current knowledge of task status and can generate customized reports providing information about the status of a project.

**Supporting the individual user.** The individual user is supported in a variety of features for:

- generating personal task metrics,
- associating notes with tasks for guidance on the task, or for journaling,
- specifying task dependencies, and
- automating tasks (e.g., for tool invocation).

**Supporting group communications.** Users are supported in a variety of features for:

- setting up and operating a shared project,
- communicating between project members, and
- providing metric information on project status.

### 5.3.2 Developer Issues

**Ease of learning.** SynerVision is in a conceptually new class of software product, is quite complex, and has many features. The novice to SynerVision must understand such concepts as tasks (their ownership, status, behavior, etc.), processes (task hierarchies and dependencies, construction of personal and group processes), communication (accessing information, communication between project member and event management), metrics specification and capture, and process template construction (using the Bourne shell and its SynerVision extensions).

Of these items the most challenging (in this author's estimation) is the manual development of process templates. As previously mentioned, this requires, as a basis, a good working knowledge of the Bourne shell language. Significant use is made of the *here* feature of the language and this, combined with the need to distinguish between variable binding at process instantiation time and process run-time, can be a considerable challenge for new users.

However, the development of simple processes (i.e., those not requiring manual construction of templates) for either personal use or group use is well supported and much easier to do. It is likely that an organization investing in SynerVision would start with these processes, work up to template customization, and then go on to the development of hand-written process templates. This incremental approach provides a safe way in which to gain the necessary experience.

**Ease of use.** SynerVision can be used in several ways. First, individuals can develop process templates for personal task management. Second, limited-size process templates can be developed to support group activities. Both of these functions can be handled without a detailed knowledge of the SynerVision template language. These templates can be generated automatically and can thus be quickly and informally prepared, tested, used, improved, or discarded without too much investment of time or resources. Greater thought has to be given when standard templates are developed for complex processes in which the greater power and expressiveness of the template language has to be used. This is likely to require significant developer training, investment in requirements definition, coding, testing, etc., and a broader consideration of the process adoption issues.

**Effectiveness of support for development.** The developer's view is accessed through the SynerVision main window (Figure 5-1) and is supported by the SoftEdit editor. The SynerVision main window contains all of the capability to develop processes and automatically define their templates. Pull-down menus are used to select supporting functionalities, such as who has access to tasks (Figure 5-2). Through the *Task* item in the menu-bar (Figure 5-1), one can select options to create sub-tasks in the task hierarchy, to instantiate a process from a template file, or to generate a new template from a defined task hierarchy. This approach is effective for developing process templates but could be enhanced in two ways. First, a more effective means for testing and debugging process models is needed (Section 5.3.1.2), and second, a process-oriented graphical front end would help define the model and communicate its nature to affected individuals.

**Quality of on-line help.** SynerVision has an extensive and excellent on-line help capability with hypertext support. The path taken through the current hypertext sequence of selections is provided above the current help page. This prevents the user from becoming lost. The major elements of the SynerVision help feature are the Step-by-Step Instructions and the Guided Tour. Also provided is an on-line Information OverView of ChangeVision. As an example of the Help features, Step-by-Step Instructions include the topics:

- Basics of Using SynerVision
- Creating and Manipulating tasks
- Setting Task Attributes
- Annotating a Task with Process Guidance Notes
- Viewing Tasks the Way you Prefer
- Project Metrics and Reports

- Creating and Manipulating Manual Task Actions
- Using Shared Projects and Tasks
- Creating and Manipulating Process Templates

However, this on-line help does not cover programming in the SynerVision template language, a feature that could be very useful.

**Error handling.** SynerVision provides both instantiation and run-time error messages. Instantiation error messages provide some insights to problems, but do not, for example, identify template line numbers where errors have occurred. The run-time error messages usually provide insightful information. In developing and running the process models, no system crashes occurred.

### 5.3.3 End-User Issues

**Ease of Learning.** There are two main classes of end-user and each has different learning issues. The first class of end user will develop personal or group processes for its own immediate use through the automated generation of process templates. While some learning is required, a major investment in time is not, since a high percentage of a process script is generated by the machine with appropriate end-user guidance. With this class of end-user, process adoption is not a primary issue since, by developing their own processes, such users are internally motivated to apply them. The second class of end user will only be expected to use pre-defined templates, and thus need not be closely involved with their technical development. Learning to use the templates should not be difficult, since the process guides the user through the sequence of tasks. However, these end users are more likely to have the automated process imposed upon them and thus may show resistance to change. Learning for them is thus less technically focused and more culturally focused.

**Ease of use.** Using the automated process is not, by itself, difficult since the user is guided through the needed process steps. In fact, if not designed effectively from a behavioral perspective, this ease of use may well make the user feel like a cog in a machine, with the potential for reducing creativity to button pushing and form filling.

**Clarity of presentation.** The standard end-user windows provided by SynerVision are shown in Figures 5-2 and 5-3. These allow for the sending and receiving of task delegation information and are straightforward to understand. However, the task information which can be displayed in the Task In-Box (Figure 5-3) is limited basically to the task name and who assigned it.

During execution of a complex process scenario, a large number of currently active tasks may be displayed at any one terminal. The Task In-Box can be used to list these tasks so long as only brief information on the tasks is required. However, if more complex instructions or decision making is required, then the Task In-Box is insufficient. For such tasks, customizing the presentation must be done and this is performed using the *svprompt* function. A typical display

generated by this function is shown in Figure 5-4. The clarity of information presented by these displays has more to do with the developer's use of the interface and the process context in which the windows are displayed than it does with SynerVision's underlying features.

However, the currently implemented *svprompt* function provides a less than adequate means for managing its windows. Many task windows, such as shown in Figure 5-4 may reside on the terminal simultaneously, taking up space or hiding each other. In addition, the designer of the process interface is not provided with any control over the placement of documents or tools, that may be associated with tasks, are displayed. Management of these various windows is an issue with which SynerVision has yet to deal.

### 5.3.4 Performance

**Execution time efficiency.** SynerVision was run on a HP Apollo 9000 Series 700 workstation running under HP-UX. The slowest common procedure with a noticeable delay is the instantiation of a process from its template. A one-task template (with eight lines of code) took 5 seconds for instantiation from the template, while the experimental model defined in Appendix B (184 lines of code) took about 33 seconds. This primarily affects developers who are debugging models and thus are required to instantiate models often, but it can also affect end users, since a process has to be instantiated from its template before it is used. Run-times for executing the process model are usually of less importance, since instant responses are not required. (For example, when one end user sends a message to another end user, the communication time is generally not critical.) As with ProcessWeaver, these times are approximate, as a regular watch was used. Variability in times, resulting from different loadings on the machine, was not a problem with SynerVision since the machine was isolated from other users.

**Space efficiency.** With respect to space efficiency, SynerVision takes about 2.7Mb of memory, while the files in the SynerVision 'bin' directory takes about 7.2Mb. The experimental model (Appendix B) takes about 8Kb.

### 5.3.5 System Interface

**Ease of tool integration.** Invoking Unix tools in process templates was simple to do using Bourne shell constructs (see Appendix B). However, directing SynerVision output to the appropriate end-user terminals created some frustration. This is in part because higher-level constructs for directing output were not available in SynerVision; this functionality had to be built up from the Bourne shell. This is one area where some simple extensions to the scripting language could be a real benefit to the process developer.

More complex integrations using SoftBench's Broadcast Message Server were not attempted.

**Portability.** At the time of writing, SynerVision is available only on Hewlett Packard Apollo computers. However, the product is planned for release on Sun workstations in the first quarter of 1994.

**Interface to the operating system.** SynerVision process models are based on the Bourne shell language which is part of the Unix operating system. In addition, SynerVision uses the Unix file system to store the process models.

### 5.3.6 Off-Line User Support

**Support from customer representatives.** Customers purchase an annual support contract for phone-in question answering and document update. Customers can also purchase specific services such as for the development of specialized process templates.

**Clarity of documentation.** The current documents which support SynerVision are:

1. Installing SynerVision and ChangeVision
2. Introduction to SynerVision: Models of Use [SynerVision 93a]
3. Developing SynerVision Processes [SynerVision 93b]

The first document was not used since it had little relevance to the technology behind SynerVision and in addition SynerVision was already installed on the HP platform. The second document provides a good explanation of the different use-models described throughout Section 5 of this report. It was very helpful in understanding the philosophy that guided the development of SynerVision and as a practical hands-on guide for exploring models that did not require template programming. The third document, which is required for template programming, is considerably less helpful and needs revision to be effective. Its principal weakness is the assumption that its readership knows the Bourne shell language. A review of this language, emphasizing the features that are commonly required in SynerVision templates, would be valuable. The document's other main weaknesses are its weak organization and lack of good illustrative examples (not just code fragments) to clarify the technical points it is making. It might have made more sense for the latter two documents to be organized as a user manual and a reference manual. A tutorial manual would also be of significant help.

**Availability of hands-on training.** Customer on-site training is currently offered. In addition, a one-day management overview course will be given that focuses on the development and use of SynerVision-supported processes.

**Availability of encoded process examples.** Since it is an example of a conceptually new class of product, SynerVision should provide some simple application examples. This would help support the successful transfer of the technology to early adopters. As a minimum, examples of simple templates for personal processes and group processes could be very useful. In addition, template programs, manually developed using the Bourne shell constructs, would help more advanced users.

## 6 End-User Role Plays

This section deals with feedback obtained from persons who performed the end-user role plays. Two groups of three persons performed these role plays; one technology oriented group of three persons and one process-oriented group of three persons. Each group performed the document review scenario with both the SynerVision implementation and the ProcessWeaver implementation. It should be noted that the number of persons participating in the role plays was small and further studies, which involve larger numbers of people, would be worthwhile. However, the results of this investigation showed some interesting and consistent results. The script shown in Table E-1 was used to guide the role-plays and, on completion of each role play, the participants filled in the questionnaire shown in Table E-2. Figures 6-1 through 6-3 below summarize the results of the end-user responses to this questionnaire.

ProcessWeaver was run from a Sun 4 host, while SynerVision was run from an HP-9000 host. In both cases, the client machines were either Sun 4 platforms or Macintoshes (using MacX). Thus the hardware environment was quite heterogeneous.

Before discussing the results, some aspects of Figures 6-1 through 6-3 are first explained. Each statement in the questionnaire is associated with five boxes which allow for a range of responses from full disagreement to full agreement. The number of responses for each box was tallied and totals are shown in the figures. These totals range from zero to four. (There were never more than four out of the six responses in any one box.) The 'Bias' column at the right hand side reflects the degree to which opinion differed between those participants with a process background and those with a technology background. A positive bias indicated that the "technology" participants were more favorably inclined to agree with the statement than the "process" participants, while a negative bias reflects the reverse. The bias was calculated simply by assigning the box number (items 1 through 5 in Table E-2) to the responses in that box, summing these assignments for the "technology" responses and also for the "process" responses and then subtracting the "process" total from the "technology" total. For example if the "technology" responses were in the boxes marked with a 2, a 4, and 5 while the "process" responses were in the boxes marked with a 1, a 3, and a 3, then the bias would be  $(2+4+5)-(1+3+3) = +4$ . It should also be noted here that the statements were designed to focus on the characteristics of the products' features and not on the process example implementations. However, this clean separation was not always possible. Hence some of the responses may be colored by the way in which the end-user interfaces of these products were constructed.

### 6.1 User Interface

Examining the data in Figure 6-1, it appears that there is a slight tendency to agree with the statements rather than disagree. If one considers the response range being from 1 (total disagreement with the statement) through 5 (total agreement), a neutral response is reflected by a 3. Averaging across all ProcessWeaver's responses (across all statements and all partici-

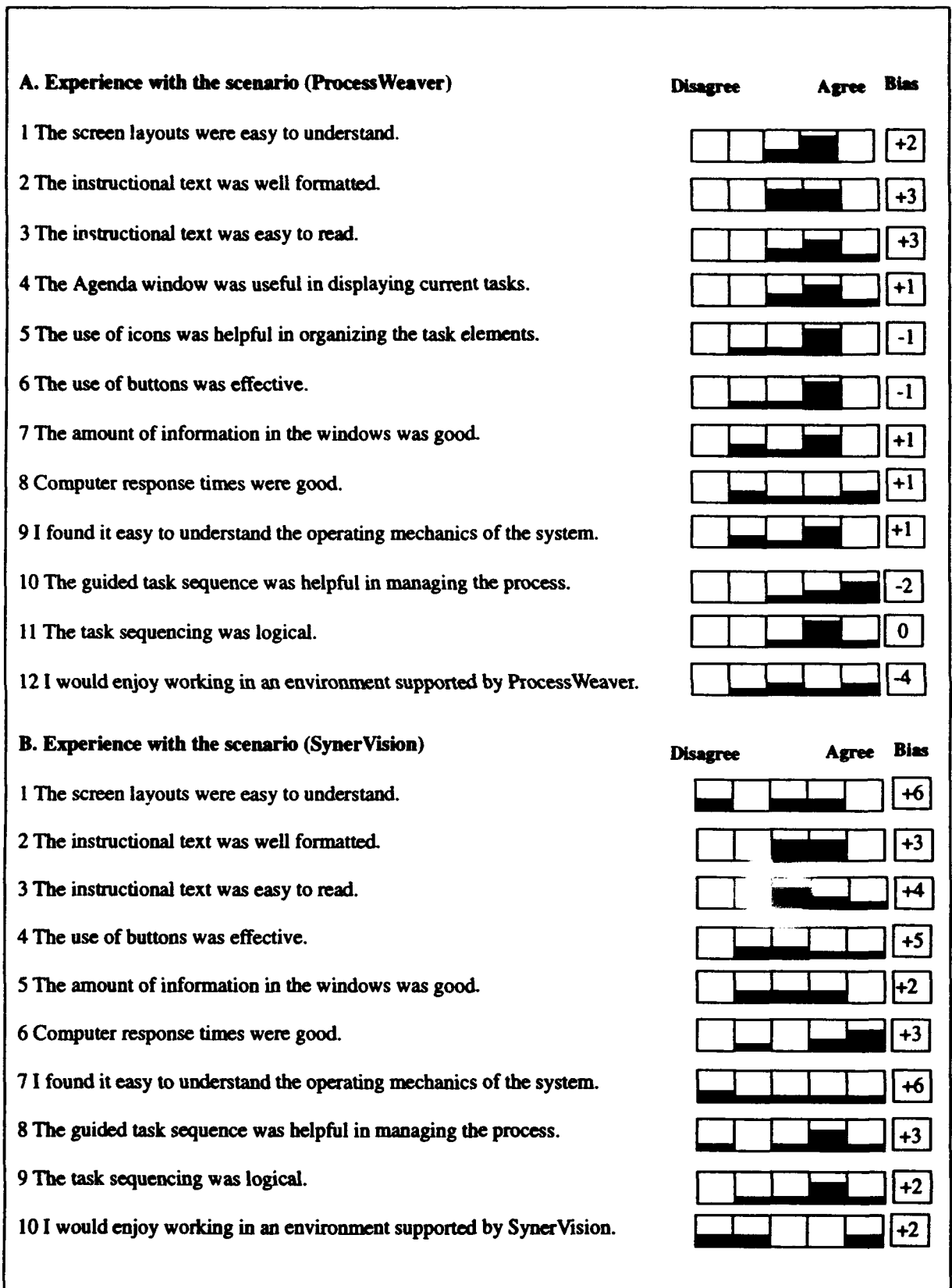
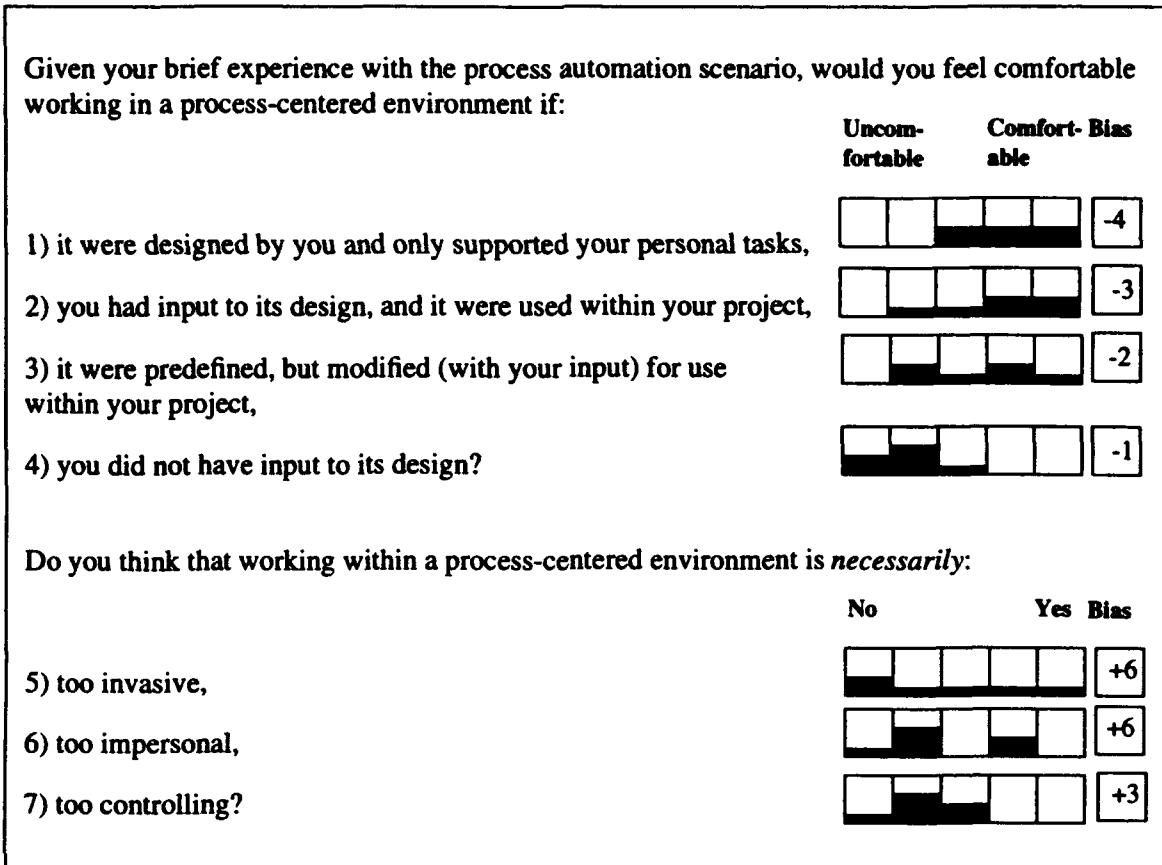
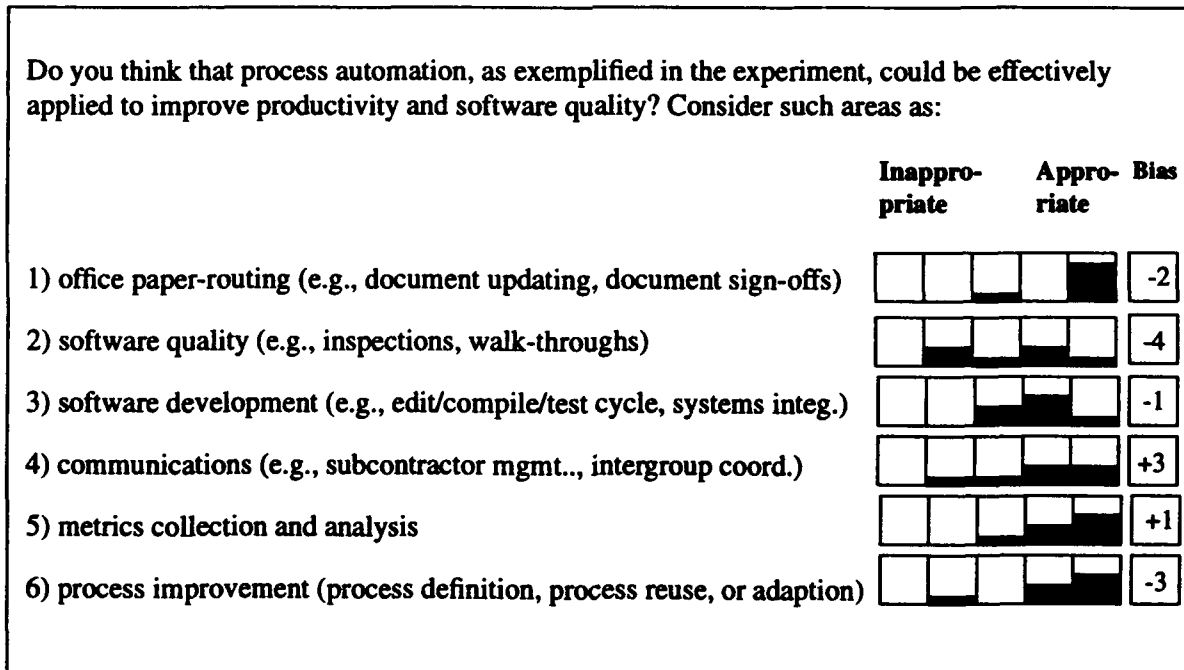

Figure 6-1: Summary of End-User Experiences



**Figure 6-2: Summary of End-User Views on Adoption of Automated Process**



**Figure 6-3: Summary of End-User Views on Appropriate Applications**

pants) the mean response is 3.64. The corresponding mean response for SynerVision is 3.21. The three categories in which ProcessWeaver's had a noticeably higher rating than SynerVision were:

- The screen layouts were easy to understand.
- The guided task sequence was helpful in managing the process.
- I would enjoy working in an environment supported by ProcessWeaver.

This result may, in part, be because ProcessWeaver manages all tasks (i.e., the Work Contexts) as icons inside its Agenda window and thus provides mechanisms for organizing and controlling one's tasks at a symbolic level. The SynerVision interface lacked this level of abstraction (see *Clarity of presentation* in Section 5.3.3).

It is interesting to note the technology/process bias in Figure 6-1. The bias column clearly indicates that the technology participants were more positively inclined to the interfaces (particularly SynerVision's) than the process participants. The one significant counterpoint to this general conclusion is the response to statement A12. Here, the process participants appeared to be more favorably inclined to working within the ProcessWeaver environment than the technology people. The following is an itemized list of (paraphrased) comments from the participants. The comments are italicized, followed by the author's remarks (non-italicized)

- *Little context is provided when tasks arrived — I may know what I have to do, but I am not be provided with adequate context. For example, when the technical writers rejected the role of editor, there is no opportunity for them to provide the reason(s) why.* This is a design problem with the process model, not a problem with either product. However, the example does point out the importance of providing human communication channels when developing an automated environment.
- *SynerVision window management was lacking functionality. When a document is invoked in the scenario, the document is simply thrown on the screen, and may cover up other ongoing work.* An inelegant solution to this problem could be devised by implementing additional buttons to allow documents (and tools) to be opened. However, a built-in feature to support this functionality should be part of the product.
- *Both products lack the capability to undo an erroneous action (such as clicking on the wrong button).* This is a necessary capability for a real-world applications. A generalization of this is process roll-back (discussed in Section 2.3.2), also missing in both products.
- *I really liked the idea of the Agenda window in ProcessWeaver, where one could keep track of outstanding work in one place.*

- **Training:** Comments clearly indicated a need for training in understanding the process. With the role play, little training was supplied. In a real-world setting, setting end-user expectations through training will be critical.
  - a. *End-user training in the use of the process automation is essential.*
  - b. *In practice, users need some form of tutorial on PCEs, either classroom style or through access to self-help materials.*
  - c. *In some cases in the scenario, it would be nice to have a bit better description of what exactly to expect and when to expect it. In this way I would know that the scenario was proceeding according to plan or not.*
- *The foundations of process automation, as exhibited by both products is impressive, but the technology has some way to go before it can be considered mature.*
- *When I shut off my terminal, do I lose all the tasks currently on the screen?*  
 This question was answered for the Macintoshes by exiting MacX (the Macintosh software which allows Macintoshes to act as terminals for X window applications). This action disconnected the running SynerVision model from the Macintosh and the connection could not be reestablished. For ProcessWeaver, tasks (i.e., Work Contexts) did persist when the same procedure was performed. On shutting down, and restarting SynerVision on the HP-9000, the Synervision task structure and the task status was recovered, but the process seemed to lack information about the process status prior to the shutdown. Thus the process could still not be continued. On the other hand, ProcessWeaver appears to store this status information since shutting down and restarting ProcessWeaver did not appear to affect the Work Contexts in the Agenda window.

## 6.2 Adoption Issues

Adoption issues are addressed here independently of either SynerVision or ProcessWeaver. Figure 6-2 provides the adoption-issue data from the end users. The responses to items 1 through 4 clearly indicate a greater willingness to accept automation if one has control over the process. Greatest acceptance is found when the processes are developed for personal use, although there appears to be significant support for these processes in which the users have input to the design. There was a consistently negative reaction to having an imposed external process.

The bias factors in Figure 6-2 indicate that process-oriented individuals were less concerned with adoption issues than were the technology individuals. This trend is particularly noticeable with statements 5 through 7 where the issues of invasiveness, impersonality, and control are examined. However, the *trends* shown by both groups were similar. (Note that the sign reversal between items 1 through 4 and 5 through 7 reflects the manner in which the statements were made and not a reversal of opinion.) Typical of the comments in this area are:

- *I would like to see the wider scope of what is happening.* This might be helped by providing workers visibility into the status of activities in the project, and by providing the ability to send explanatory or confirmational messages.

- *Whether I felt comfortable in an automated environment would depend on how process-driven I was. Acceptance might also be easier if one were new to a project or if the project itself were new (i.e., there are no built-in expectations) rather than if a unfamiliar process were imposed upon an existing project.*
- On working in a process in which the user does not have input:
  - a. *I would be uncomfortable working in someone else's process.*
  - b. *If I do not have any input to the design of the process, there's a chance I could live with it, but if it does not match my reality, I would be dissatisfied.*
- Comments of the 'too invasive' issue:
  - a. *It could be too invasive if it tells me how to accomplish work instead of telling me what needs to be accomplished.*
  - b. *Unlike e-mail I cannot elect when to receive information.*
  - c. *It's too invasive only to the extent that windows get popped in front of you while you are concentrating on something else. The second issue is one of metrics gathering coupled with personnel evaluations. If this is not handled well (i.e., the ground rules are well established, well known and accepted), it could be a really big issue. Otherwise I don't feel a process-centered environment is too invasive.*
- Comments on the 'too impersonal' issue:
  - a. *It's no more impersonal than with e-mail. As with anything else, process automation is not a substitute for communication between staff.*
  - b. *Automated environments would likely reduce personal interaction with other human beings.*
- Comments on the 'too controlling' issue:
  - a. *I find the elimination of process navigation concerns to be a relief. I can have the files and tools I need when I need them. It allows me to concentrate on the work, not the setup.*
  - b. *Where do I get a chance for input other than "yes-no"? The machine controls my destiny with no human on the other end (or so it seems).*
  - c. *The only way it would be too controlling is if the process-centered environment restricted all of my efforts to exactly what the process is scripted for. As long as this is not the case, and the environment is providing timely guidance, this is OK with me.*

### **6.3 Application Issues**

Contrary to the results in Section 6.2 where concerns were raised about adoption of process automation technology, Figure 6-3 indicates that there was a fairly positive response to applying the technology to particular areas. In this section, the Bias indicator did not show any consistent trends between the technology and process individuals. The three applications where process automation was seen to be most suited were: office paper routing, metrics collection and analysis, and process definition and improvement. The following are typical comments:

- Office paper routing:
  - a. *Somewhat helpful, particularly in getting sign-offs.*
  - b. *Excellent application, particularly if the tool supports tracking.*
- Software quality:
  - a. *Too people-intensive, a PCE doesn't add much.*
  - b. *I think the quality of inspections would decrease without face-to-face meetings.*
  - c. *For coordinating inspections, walk-throughs and for follow-up action items, this would be good.*
- Software development:
  - a. *Good for the individual.*
  - b. *Good for automating a tasks that are (almost) always followed in the same sequence.*
  - c. *If it is supported by automated metrics collection, such as time spent in each phase.*
- Communications:
  - a. *Yes — if it makes sure everybody gets appropriate mail and info.*
  - b. *Only appropriate if everyone has PCE support.*
  - c. *PCEs should make communication as easy as with e-mail.*
  - d. *A great way to ensure some form of recorded communications.*
- Metrics collection and analysis:
  - a. *Definitely could make these activities easier.*
  - b. *Must watch out for gathering too much, or irrelevant information.*
- Process improvement:
  - a. *I think it would be a BIG mistake to encode process this way for a development group.*
  - b. *Looks like a winner for assisting activities in process improvement.*
  - c. *Good for process definition. However, need for a process asset library.*

As can be seen from the results above, there were clear differences of opinion, ranging from enthusiasm to concern, as to the effectiveness of applying automation to software development process. There was a slight but noticeable and fairly consistent divergence of opinion between those with a technology background and those with a process background. As might be expected, the technology-oriented participants viewed process automation with greater degree of scepticism. Since involving technical personnel will be central to successful implementing process automation, it is important to identify and deal with the issues technology-oriented individuals raise.



## 7 A Comparison of ProcessWeaver and SynerVision

The objective of the experiments conducted with SynerVision and ProcessWeaver is to explore an emerging technology using these products as examples. Both of these process-centered frameworks have powerful mechanisms for enacting process and both, as members of a new class of software, have their weaknesses. In any case, the successful application of either PCF (or other PCF as listed in Appendix A) is likely to depend as much on organizational and human factors as on the product selected. Such issues as having an effectively defined process, good developer and end-user training, and sensitivity to technology adoption issues will be at least as important for success as the chosen PCF.

ProcessWeaver and SynerVision have many similar capabilities, but implement these capabilities in different ways. Currently, both SynerVision and ProcessWeaver do not differentiate between the process developer and end user — each PCF provides the same functionality to both groups. This allows end-users to implement their own personal processes or define processes for local project support, as well as allowing for the development of more ambitious processes. However, there may be a need, particularly with large processes, to distinguish between process-developer and end-user capabilities. Both PCFs implement reuse templates so that a process can be instantiated and enacted from a library of previously defined processes. Both PCFs allow the end-user to enact subprocesses, independent of the parent process to which they are associated. While tasks form the “building blocks” of processes in both PCFs, tasks can also be initiated, communicated, and worked on by end users in isolation from any process.

It should be noted that neither of these PCFs is repository-based, and in that sense they emphasize the control aspects of process rather than the data management aspects. Thus neither has mechanisms for handling versions of products, or for controlling potential conflicts that can arise from multiple agents modifying the same product. Data-centered products that have emerged primarily from the configuration management community are also entering the market place. Such products (e.g., CaseWare) do provide a repository and also allow one to define and enact the processes that focus on a product's evolution. However, these CM products have narrower process modeling capabilities. Integration of PCFs with configuration management products is probably needed, but since CM and PCF products may have different notions of “process,” care is probably required in this effort. It should also be pointed out that neither ProcessWeaver nor SynerVision support some of the groupware concepts such as simultaneous, remote collaboration on work, for example, in editing a document.

There are also some noticeable differences between the two products. ProcessWeaver emphasizes a graphical approach to process definition. This approach defines a process by graphically specifying an activity hierarchy, each activity being supported by a lower-level Petri net model. In SynerVision, processes are defined in a text-oriented manner using an activity hierarchy, which is supported by scripting that specifies task behaviors and dependencies.

SynerVision integrates some end-user applications,<sup>9</sup> while a design decision was made with ProcessWeaver to focus strictly on process support,<sup>10</sup> allowing for application extensions to be added as required. The following topics highlight some of the similarities and differences in more detail.

**Developing process models.** With both ProcessWeaver and SynerVision, simple process models can be developed without any knowledge of their textual scripting languages. Because of its built-in project management and metrics tools, SynerVision allows one to develop reasonably sophisticated models without knowledge of its textual language. Also, as discussed in Section 5.1, SynerVision's design provides a smooth incremental learning curve from supporting simple personal tasks to managing of group tasks. However, when one needs to describe processes that require the explicit writing of SynerVision scripts, the learning curve becomes much steeper.

As stated above, ProcessWeaver does not provide built-in metrics and project functionalities that SynerVision provides. Thus, to include such capability in ProcessWeaver, one may have to start using ProcessWeaver's scripting language at an earlier point than with SynerVision. However, because of the graphical nature of much of the ProcessWeaver model, the degree to which the scripting language has to be used may not be significant. Through ProcessWeaver's graphical approach, both the activity hierarchy and the process models associated with each activity are defined. This approach provides two advantages:

- model development is faster, and
- fewer syntactic and semantic errors are introduced.

SynerVision's approach to model definition is textually oriented (see Figure 5-5). The activity hierarchy can be displayed graphically, but this is somewhat superfluous as the textual view is quite adequate (see Figure 5-1). However, because of the textual approach, building SynerVision process models by hand requires a greater investment in learning the language and is more time consuming than with ProcessWeaver's graphical approach. Productivity in constructing SynerVision models could also be improved if SynerVision had a richer set of higher-level functions. During the construction of the experiment, it was found that time was spent developing supporting functions from Bourne shell elements and it would have helped if these had been built in.

While the graphical process support provided by ProcessWeaver is very helpful in developing models, neither SynerVision nor ProcessWeaver supported by a true graphical process enactment language. A graphical process enactment language is desirable in order to communicate all the essential process elements to others who will either have to sign off on a process or

---

<sup>9</sup>. That is, it has characteristics of a process-centered environment (PCE) since it supports end-user capabilities for metrics collection and project management.

<sup>10</sup>. That is, version 1.2 of ProcessWeaver is strictly a process-centered framework (PCF).

who will have to live within it. In addition to defining the relationships between all the major process elements, such a graphical language should be able to display tasks, artifacts used by tasks, and the agents (or roles) who perform the tasks.

The software underlying both SynerVision and ProcessWeaver was found to be robust in the sense that no system crashes and no significant system bugs were encountered during development.

**Templates, roles, and process instantiation.** Both SynerVision and ProcessWeaver have explicit mechanisms to allow for the initiation of isolated tasks and for sending these tasks off to the persons responsible for their execution.

With respect to processes (that embed tasks) SynerVision and ProcessWeaver provide for the development of process templates that allow for the repeated use of defined processes. If one develops a process in SynerVision, there is an explicit step that must be taken to generate a template from an existing runnable process. However, in ProcessWeaver, one develops models as templates (which, in turn, may embed default Cooperative Procedure templates). In either case, an instance of the template is generated and executed at run-time.

Every Cooperative Procedure in ProcessWeaver provides a *parameters* box to the process developer in which variables required for the execution of that process are placed. Later, at run-time, ProcessWeaver presents the process executor with a *procedure parameters* box in which the variable instances are filled in. In SynerVision, the process developer must explicitly build such mechanisms into the model using the scripting language. This is an example of where the process developer's task could be simplified if higher level functionality were built into SynerVision.

A SynerVision process model is basically contained within one file. This was found to be very useful for electronically transmitting the model to a remote location when debugging support was needed. Because a ProcessWeaver model consists multiple files, such a procedure becomes less convenient.

**Process control.** Process definition in ProcessWeaver is based on a Petri net formulation, and this has resulted in one overly restrictive characteristic. Before a task in a Cooperative Procedure can begin, all the upstream tasks must have been completed. In real situations, it may be possible for someone to start a task before all the formal conditions for task initiation have been met, and indeed this opportunistic behavior may result in greater productivity. Section 4.3.1.1 discussed a possible resolution of this problem.

SynerVision does not exhibit this modeling constraint. Unless explicitly specified to the contrary, an agent responsible for performing a task can begin at any time. Clearly there will be tasks that must not start prior to other tasks ending, but this can be specified in the model.

**Accessing external tools and the external environment.** SynerVision allows access to external tools using the standard Unix mechanisms and can communicate with its external environment using the functionality provided by Hewlett Packard's Broadcast Message Server.

ProcessWeaver supports similar mechanisms for tool invocation and communication. ProcessWeaver and SynerVision both provide a convenient means for associating tools with tool classes. Thus on different platforms or with different users, different tools within the same class may be invoked.

SynerVision provides project management and metrics capabilities that are seamlessly integrated into the product. Processes can be developed incorporating these tools without a knowledge of the SynerVision scripting language. In addition the metrics tools provide the capability to gather metric data such as time spent on a task without any intervention on the part of the task owner.

ProcessWeaver provides project management support through integration to external tools, but this is not as integrated as SynerVision's support. Two tools are currently supported by ProcessWeaver are: MicroSoft Project for Windows and Project Management Workbench 3.1 (under PC/DOS).

**Debugging.** ProcessWeaver provides a variety of tools to support debugging. These include support for consistency checking (e.g., between inputs and outputs of Cooperative procedures), syntax checking of scripts, interactive debugging for the Co-shell language, and process visualization (that allows one to view tokens as they move around the Petri net and to spy on variable values during this process). SynerVision does not currently support any debugging aids other than that provided by the interactive *shell* that comes with Unix.

**Documentation and examples.** Neither SynerVision nor ProcessWeaver currently provide adequate documentary support. SynerVision's manual *Introduction to SynerVision: Models of Use* [SynerVision 93a] provides an excellent grounding in those aspects of SynerVision that do not require one to program. However, the more advanced manual, *Developing SynerVision Processes* [SynerVision 93b], is less well organized, needs improved explanations of the concepts, and should contain a greater number of complete examples rather than code fragments. This manual tries to be both a reference manual and a tutorial, and these two focuses should probably be separated. SynerVision has extensive on-line support that supports the development of processes that do not need manually-encoded scripts.

The ProcessWeaver manuals (User and Reference) have three significant weaknesses. First, the User Manual lacks a good explanation of how the high-level elements of ProcessWeaver (Methods, Cooperative Procedures and Work Contexts and their supporting information boxes) relate to each other. Second, the Reference Manual needs to provide expanded coverage of the concepts in event handling supported by illustrative examples. Third, the Reference Manual should provide more background into the functions that support the manipulation of the files stored under ProcessWeaver's Universal Storage Mechanism format. In this version of ProcessWeaver (1.2) on-line help was not implemented.

Both SynerVision and ProcessWeaver lack a good library of illustrative and executable process examples.

***The end-user view.*** ProcessWeaver provides a means of easily customizing, within a limited format, the information that is sent, either from one person to another, or that is sent to a person as a result of an automatic action. This window is called a Work Context (see Figure 4-2) and allows for text boxes, document or tool icons, and control buttons to be displayed. Upon clicking on an icon, a window containing the document or tool is opened for use. This end-user window management in ProcessWeaver was found to be quite effective.

SynerVision provides three main types of window for displaying end-user information. First, a Task In-box (see Figure 5-3) is provided that simply lists a person's assigned tasks along with the names of the task assigners. The main purpose of this window is to allow the assignee to accept, reject, or reassign a task. Second, customized windows can be developed that contain both textual information related to the task, and control buttons. However, neither the Task In-box nor the customized windows can display icons representing documents or tools. A supporting document or tool can, however, be opened as needed to support the task, and this is done by writing a line or two of Bourne shell script. However, this approach is not very elegant and SynerVision could incorporate improved functionality for managing end-user windows, particularly with respect to the support of task-related documents and tools. Finally, the *Notes* feature may be used to supply the end-user with guidance on the task at hand or to document how a task was accomplished.

In summary, each PCF has different strengths and weaknesses. There is no "best" product — it truly depends on one's needs. For example, ProcessWeaver provides developer-friendly support for graphically-based model building, while SynerVision has effective built-in support for project management and automatic metrics gathering. SynerVision provides more extensive capability for the project with modest process enactment objectives (when one can build models without having to resort to hand-coded shell scripting). On the other hand, the higher-level functionality for building and debugging process models may make ProcessWeaver a more attractive choice when large models are being considered. The choice of which product to use (including the others listed in Appendix A) has to be made based on the requirements of the project for which the process enactment model is being built. Both reviewed products show significant insights into what is needed for effective process enactment, but the implementation paths have gone in different directions. The technology has some way to go before reaching maturity, and practical field experience will make it more robust and provide the vendors with greater application knowledge.



## **8 Adopting and Using Process Automation Technology**

Because there is as yet little industry experience in automating large-scale software processes, it is wise to proceed cautiously. The following three subsections discuss some conservative guidelines to follow when adopting this technology as well as providing some practical steps to its implementation.

### **8.1 Process Automation and Process Maturity**

Automated processes are more "brittle" than manual processes, i.e., they are less adaptable to unforeseen circumstances and they cannot be modified as easily on the fly. Thus an understanding of one's manually-driven process is a prerequisite to the success of process automation. It can be argued that a CMM Level 1 organization should not use a process-centered framework for critical processes if these processes are not already understood, stable, and well-defined. While it is tempting to think that a process-centered framework can help move a organization from Maturity Level 1 to Level 2, stable manual processes (an essential ingredient of a level 2 organization) will significantly reduce the risk of implementing a PCF. There is also a concern that a Level 1 organization will become too preoccupied with the PCF technology rather than focus on the main issue which is process improvement.

This is not to say that a Level 1 organization cannot use some of the functionality provided by PCFs (such as supporting individuals in product development) or experiment with them in small-scale noncritical areas, but experience should be gained before process automation is imposed on critical parts of one's product line. Application to small-scale, noncritical areas will provide a means to learn and gain confidence about both the technology and the adoption issues.

### **8.2 Guidelines for Adopting Automated Process**

Adopting any new technology is likely to meet with significant resistance. Because of its pervasiveness and potentially impersonal nature, this is particularly true with process automation. As with any new technology, some of this resistance will simply result from the fact that people often do not like to change from their comfortable routine to new and uncertain ways. However, some resistance will also come from reasons unique to process automation technology. Such reasons are related to the controlling nature of the technology and the automated collection of personal productivity metrics. Typical reactions to these changes will include:

- Now I don't talk to people, I only communicate through my terminal.
- I don't want management to know every move I make.
- I don't want to be treated like a cog in a machine.
- I know these metrics are going to be used against me in my annual evaluation.

Such comments reflect the natural fears of staff members, particularly if management is viewed as authoritarian. Some of the resistance reflects a general reluctance to any change which significantly affects how one does one's job. However, process automation imposes behavioral changes that are unique to that technology. Most computer tools (for software development, project management, etc.) are passive in the sense that they respond to the commands of, and perform actions to support, the human agent. Process automation is different in that it can request actions of the human. While the roles of the computer and human are not entirely reversed, this puts the computer at the same status level as the human (since the human can still request the machine to perform actions too). This question of roles may be difficult for many to take, and is a major reason why adoption issues for process automation technology are so critical.

If management wishes to succeed, then it has to create an environment of trust that can only be achieved through closely involving the people who will have to live within the system. While Henry Ford may have been able to impose his will on the men in his assembly line by increasing their wages, such a crude approach is unlikely to work in the software field [Womack 90, Yourdon 92]. More sensitive strategies have to be used. The following points provide some experience-based guidelines which may be useful to address when considering the application of process automation technology. [Fletcher 93] discusses similar issues with reference to CASE.

1. **Resistance to change.** Resistance should be expected. Overt resistance is to be encouraged otherwise it can easily become covert and undermining. Issues, such as those in the bulleted list above, should be aired and discussion encouraged. Out of such discussions, ideas and approaches may be found, which, as well as being excellent in their own right, will foster a feeling of "buy-in". Some of the strategies suggested in the paragraphs below relate to resistance and its resolution.
2. **Process ownership.** The philosophy of pushing down responsibility to as low an organizational level as possible should be adopted. Thus the group responsible for performing a process which is to be automated should help define, and should feel that it has ownership of, that automated process. This may be done by encouraging close collaboration between the user group and a software engineering process group (SEPG). The SEPG should know how to elicit information on the current processes and identify the user-group's requirements on its automated equivalent, by:
  - knowing how to define process models,
  - knowing how to implement and validate enactable models,
  - understanding metrics collection and analysis issues, and
  - having the necessary skills to address adoption/transition issues.
3. **Training.** Training (for example, on process definition/automation, metrics collection and analysis) and setting expectations (for example, no layoffs resulting from automation, non-attribution of metrics data etc.) are significant contributors to the success of this adoption task.

4. **Process improvement.** In the same way that a group operating a process should feel ownership if it, the group should also have the responsibility for improving it. Thus the group should be responsible for collecting and analyzing its own process metrics, encouraging suggestions for enhancing the process and for implementing changes. These changes should, of course conform to the organizational standards (see Item 8 below).
5. **Process metrics.** Process metrics should be managed by the group and should be non-attributable to individuals. With the automated metric collection, access to confidential metric data should be controllable, thus assuring those involved that such data will not be used in employee evaluations. Only non-attributable data is passed up the management chain. Person-specific metrics are used by the group only to improve the group's process; group-averages may then be used to support the improvement of higher-level processes.
6. **Organizational context.** Project processes should be defined within the broader context of the organization. Thus the organization has the responsibility to develop process definition standards (e.g., type of process definition/enactment methodologies), process interface standards (to allow for compatibility between project processes and higher level processes), and data format standards (to allow for information consistency between projects). However, broad organizational standards should only be imposed after sufficient exploratory experience is gained with process automation at the project level.
7. **Process interfaces.** Broad higher-level process models may be used to guide the organization of the lower-level processes and information flows. However, these higher-level processes should not specify the details of the individual processes. Detailed process definition should be a bottom-up task (using the standards). The top-down model may be periodically revised as a result of bottom-up integration of tasks. In this way the model is organic, being neither completely top-down nor bottom-up. Constraints on the construction of individual processes include:
  - inputs and outputs (both artifacts and decisions), derived from the higher level,
  - guidelines and standards on process definition, and
  - data formats.
8. **Transitioning strategies.** To institute automated processes in an existing project, real-time validation may be required before commitment to the new process is made. One approach to this is to run the old (perhaps manual) process in parallel, side-by-side with the new automated process, making sure that the inputs to both are identical. Outputs are then compared for some time to assure that they are identical. In cases where the old and new processes are not the same, the two processes can still be run side-by-side until sufficient confidence is gained that the new process is providing correct output (parallel strategy). Another strategy is to incrementally insert small components of the automated process into the old process in such a way that the change-over to the new process occurs gradually (incremental strategy).

9. **Process reuse.** Processes that have been successfully run by one project can be captured in a corporate repository for use or modification by others. This not only reduces the effort in implementing processes in subsequent projects, but will support the drive to organizational consistency of process and encourage communication between projects.
10. **Granularity of process control.** The manner in which a process is modeled should depend on the application area. In general, processes closer to technical development should provide increasing degrees of support or guidance and decreasing degrees of imposed control. For example, developers are unlikely to accept a level of overt, external control in which every act in the edit/compile/test cycle is regulated. However, they may wish to support their activities by developing their own personal process scripts. On the other hand, persons managing change requests or document review activities may be very happy to have the support of an externally defined process in order to lift some of the administrative burdens from their shoulders.

### 8.3 Transitioning to a PCF

In order to install an organization-wide integrated software development environment (not necessarily a PCF), significant planning must be done [Humphrey 89]. While Humphrey suggests a two-phase strategy, the following approach expands that suggested by him and has three phases. The first phase is exploratory and allows for technical and adoption experience to be gained. This phase may be done by projects having the characteristics of an organization at Maturity Levels 1 or 2.<sup>11</sup> The second (strategic) phase involves planning for organizational adoption and requires the organization to be at least a high maturity Level 2. The third phase covers actual implementation of process automation within projects as directed in phase 2.

#### *Phase 1: Exploration*

This phase is very important in allowing an organization to assess the appropriateness of process automation for its culture, prior to making significant investments. Thus implementing one or more pilot processes should be the first step. Before starting, it is probably wise to read about technology change management. Little has yet been written explicitly about adopting process automation, but many of the issues are the same as those in the adoption of other technologies. Excellent places to start are [Oaks 92, Humphrey 89, Fletcher 93, and Block 81]. The paper by [Dart 94] illustrates how close the issues of adopting automated configuration management are to that of adopting automated process. The following criteria are suggested in selecting an appropriate process to be automated:

---

<sup>11</sup>. The Capability Maturity Model [Paulk 93a] associates maturity levels with organizational characteristics, not project characteristics. However, nearly all of Level 2 practices within the CMM focus on project characteristics. It is in this sense that the term "a project showing Level 2 characteristics" is used. Of course, the term "a project showing Level 3 characteristics" makes little sense.

- the process is modest in size,
- the process is well understood and stable,
- the process is not on the critical production path of external products,
- the project, of which the process is a part, is not constantly putting out "brushfires", and
- the users of the process are positively inclined to automation.

### ***Phase 2: Strategic planning***

Once confidence has been gained through the demonstration process(es), the knowledge and skills gained can be put to use in developing a strategy that will allow wider and consistent implementation throughout the organization. The following activities are suggested:

- Establish an automation focal point (an individual). This person was probably part of the Phase 1 activities, could be part of a software engineering process group, and must have an understanding of issues related to technology, process and adoption. Communication is also an essential skill for this individual.
- Define application focuses for automation (i.e., individuals, projects leaders, upper management and corporate staff).
- Develop a high-level requirements statement for the automation project. Include requirements for:
  - communication,
  - metric data collection,
  - management tools,
  - development tools,
  - data repositories,
  - vendor support, and
  - training.
- Establish a strategic plan for PCF for adoption and maintenance.
- Assess the most promising PCF.
- Establish a corporate process reuse repository.
- Develop a handbook for the adoption of automated process which covers the technical, adoption, training, and reuse issues.

### ***Phase 3: Project implementation***

With experience in hand from the demonstrations, and the organizational framework provided by Phase 2, implementation throughout the organization's projects can begin. For this phase, the following activities are suggested:

- Establish an implementation group composed of experts in the automation technology and members of the affected project. If necessary train individuals in the PCF and in adoption techniques.

- Identify and evaluate project-based costs, benefits and risks associated with adoption of process automation.
- Develop project and application-specific process automation objectives and implementation plans.
- Develop project and application-specific migration strategy based on the handbook for the adoption of automated process.
- Define, develop and implement the process templates based on the handbook for the adoption of automated process.
- Validate the effectiveness of the process by involving future users in simulated process role-plays (see Section 6)
- Provide training and hands-on experience for all affected parties.
- Track the progress of the automation project (getting feedback from users), document lessons learned, and improve the process model.

It may be helpful to expand on the activity of defining a project's migration path by suggesting one possible scenario. This scenario assumes that Phases 1 and 2 have been completed and that Phase 3 (project implementation) is starting. As mentioned above, a project showing Level 1 characteristics will not have the process maturity to effectively use a PCF in the broad sense. A project with level 2 characteristics is therefore chosen to pilot the installation. At this point, the manually defined process is chosen and adapted for automation using the organization's standards. It is then tested off-line through simulation. Critical project members are closely involved in these activities. The functional elements supported by the PCF may include development tools such as compilers, debuggers, etc., or management tools such as for project planning and cost estimating. At this point a transition strategy must be planned and implemented, and could, for example, use either the parallel or incremental approach discussed earlier (see Item 8 in Section 8.2). Transitioning the automated process into the project also requires that the project members be trained in how to work and feel comfortable with the automated process.

When sufficient confidence has been reached with the first project, other projects transition to the use of the PCF, perhaps while concurrently achieving Maturity Level 2 characteristics. In adopting the PCF, these latter projects will have to conform to the data standards set up for the repository. This not only allows projects to communicate, but also sets the stage for the organization to reach maturity Level 3. At Level 3, a major focus is on organizational consistency of process. Thus each project's process will be tailored to reflect the organization's standard process. The process, as defined for each project, will be developed using standard process modeling tools and stored within the organization's repository under CM control. Also, in moving towards Level 3, the organization will support access tools allowing upper management to query the repository. This is possible since data across the organization is now stored in a consistent manner.

The functionality provided by the PCF will need to accommodate changes in the process as process improvement takes place. Increasing complexity is to be expected as new requirements, greater process complexity, and product variety are imposed. Significant

modification of the process program is also likely since mistakes will be made as experience is gained. If the process model is not resilient and flexible, it is likely that continued modification of the associated software will overstress the original concept. This problem of process evolution and maintenance affects not only the process template design, but also challenges the underlying mechanisms provided by the process programming language.



## 9 Summary and Conclusions

As software systems have grown in size and complexity, the ability to predictably manage them with respect to cost, quality, and on-time delivery has declined. This has led to an awareness of the importance of well understood software process as an essential ingredient in software development [Humphrey 89]. However, managing all the elements of software process requires a significant investment in time and resources, and this may discourage organizations otherwise favorably inclined to process improvement. Fortunately elements of many process-related tasks can be automated, providing support for both developers and managers in their day-to-day efforts. Approached in the right manner, automation of the process has the ability to bring improvements in both quality and productivity.

Automation can support process activities in many ways. Some of the important ones are:

- It assures that the development process is actually followed and can provide a "paper trail" of the sequence of activities performed.
- It allows developers to communicate with each other and coordinate tasks with less effort.
- It can support project oversight by providing project and upper management with the current status of development activities.
- It can automatically link to project management tools, thus making updates to project plans much simpler.
- It can reduce the chance of many process-related errors occurring by transferring process control to the enacted model.
- It can support the automatic collection of metric data, thus eliminating the time consuming and error prone tasks of manual collection.
- It can automatically provide input to a corporate repository to support process improvement and project estimation.
- Through automation, many menial tasks can be removed from human involvement.
- Process automation can provide a setting in which the developer has easy and context-dependent access to the tools he/she needs to perform the tasks.
- Finally, it can contribute to process reuse since a defined and validated model can be captured in a process database.

It should be noted that there are also some potential pitfalls to using this technology. Most importantly, a process-centered environment cannot be viewed as simply a CASE tool to be imposed on a developer. Process automation involves at least the whole project and perhaps the broader organization. Any process-centered framework will impose ways of doing things that may differ significantly from past experience. If not approached correctly, users of such a PCF could easily subvert it. A second issue is that of working within a defined process. It is unlikely that an automated process can be successfully implemented without the project having a well understood and stable manual process. This does not imply that the automated process need

slavishly follow the manual process, but without an understanding of the basic project tasks and information flows, etc., it is unlikely that the automated process will succeed. PCFs are fragile in the sense that they cannot easily change strategy in mid-stream if problems arise. Humans have a remarkable ability to adapt to unforeseen circumstances; software systems have still to learn this ability. Finally, PCFs are not a panacea, and indeed are still in their infancy. Adopters cannot rely on the practical experience of others as there are, as yet, few examples of day-to-day industrial use.

Two PCFs, ProcessWeaver from Cap Gemini and SynerVision from Hewlett Packard, were examined in some depth in order to better understand the technology. It was found that they provided some functionality in common, but also differed in a significant number of ways. Characteristics in common include the ability to generate process templates thus allowing for process reuse, the ability to support personal task management in addition to implementing predefined task sequences (i.e., processes), the ability to develop simple processes without having to know either PCF's scripting language, and an interface that serves the needs of both the developer and end-user. This latter feature allows end-users to develop simple processes for themselves or group use.

Differences between these PCFs include the following. ProcessWeaver's approach to developing models is primarily graphical. A process is defined at a high level through an activity hierarchy, each activity being supported by an associated process diagram. These process diagrams are defined using a Petri net notation. This graphical approach allows for a rapid process development and helps reduce the likelihood of errors. SynerVision essentially uses a textual approach to defining the process. An activity hierarchy is defined textually (although a graphical representation of this is available), and each of the activities has actions that are performed to satisfy it. Other information, such as dependencies between activities, may form part of the activity definition. ProcessWeaver's Petri net approach is less flexible in that one must complete all upstream tasks to the current task before it can begin. With SynerVision one can begin a task any time providing that the necessary inputs are available and there are no explicit constraints imposed by the process model.

SynerVision provides an effective suite of tools for automatically capturing different metric data and for performing simple project management functions. These two features support each other since both rely on the same types of data. On the other hand, the version of ProcessWeaver which was evaluated (V1.2) provides links to connect to project management tools but does not provide this functionality directly. ProcessWeaver's lack of support for process metrics is seen as a weakness since there is such a close relationship between process automation and the collection of process metrics. ProcessWeaver does, however, provide useful features for debugging process models, from consistency checking to simulation. To date SynerVision provides little support for debugging. Information windows, that provide the end user with task-dependent messages for guidance and control buttons for decision making, are used by both SynerVision and ProcessWeaver. ProcessWeaver has the added capability of display-

ing icons in these windows. These icons can represent documents or tools and can be opened to display the document (in, for example, a word processor) or tool, and provide a very effective means for managing tasks.

The documentation of both ProcessWeaver and SynerVision could be improved. One of SynerVision's manuals provides a good explanation of the product if one is only going to generate processes without invoking the scripting language. However, the manual that describes the scripting language needs to be clarified and reorganized. ProcessWeaver's documentation provides a good explanation of the product's major elements but fails to adequately explain how these elements fit together. ProcessWeaver's manual could also provide expanded coverage of the product's lower level features. Both products could be significantly improved if they were supported by a wider set of executable examples and simple application cases (similar to the one developed in this report).

In conclusion ProcessWeaver and SynerVision both had the functionality to construct the experimental model described earlier, and provided robust environments in which to build and enact the models. There were frustrations during model construction and debugging, and these resulted from:

- inexperience at using the methodologies,
- product features that reflect early technology,
- less than adequate documentation, and
- lack of good illustrative and executable examples.

Unlike coding tools whose users typically have a sophisticated programming background, PCFs will have a less technical, and more process-oriented set of users. Both SynerVision and ProcessWeaver have features that indeed support nontechnical users, but the needs of these users could be more adequately addressed. The basic technical approach used by either product is believed to be solid and form a good foundation for process automation. The current limitations of these products (most likely reflected in other PCFs; see Appendix A) are to a great extent a consequence of the newness of this technology, and it is hoped that these limitations will be removed in time.

Process-centered frameworks provide the structure to support process automation. However, successful introduction of this technology imposes fundamental changes in the way software is developed. First, application of process automation is more likely to succeed if the organization's processes have already been defined and operated manually. This not only provides a basis for developing the automated equivalent of the process, but educates the organization's staff on what it is like to work within a defined process. Second, imposing an automated process requires a significant degree of trust between developers and management since it can be perceived as being intrusive. Two major implications of this are:

- in order to encourage feelings of ownership, affected project members should be closely involved in developing or adapting process to meet their project needs, and
- automated metrics collection is designed to assure that the data is used to improve the process and not to evaluate an individual's performance.

Third, to achieve success in process automation, a transition strategy is necessary. It is suggested that a three phase approach is used. The focus of the first phase is gaining experience with the technology and its adoption in small, noncritical processes. The second phase then involves strategic organizational planning, while the third phase involves implementation across multiple projects. The strategic plan must have the visible and continued support of upper management since the culture changes introduced by process automation will be significant and will likely be resisted.

The future of process automation has yet to be decided. Potentially it can bring dramatic improvements in software productivity and quality, but questions remain to be answered. Is the technology sufficiently responsive and adaptable to human needs? Conversely will implementers be sufficiently aware of the critical human-factors issues? Will early failures at automation prematurely give the field a bad reputation? Will resistance to working in an automated process be a major impediment? Will process automation products be sufficiently flexible to describe most process characteristics and sufficiently scalable to model "industrial-strength" projects? While answers to these questions will only be resolved in time, awareness of the issues and plans to deal with them will immeasurably improve the chances for success.

## References

- [Block 81] Block, P. *Flawless Consulting*, San Diego: Pfeiffer and Co., 1981.
- [Boone 91] Boone, G. "CASE and its Challenge for Change", *International Journal of Software Engineering and Knowledge Engineering* 1,2 (1991): 151-163.
- [Brown 92] Brown, A. W.; Earl, A. N.; McDermid, J.A. *Software Engineering Environments: Automated Support for Software Engineers*, New York: McGraw-Hill, 1992.
- [Brown 93a] Brown, A. W. et al. "Experiences with a Federated Environment Testbed", *Proceedings of the European Software Engineering Conference*, Garmisch, Germany: Springer Verlag, September 1993.
- [Brown 93b] Brown, A.; Carney, D.; Oberndorf, P. & Zelkowitz; M.; eds. *Reference Model for Project Support Environments*. (CMU/SEI-93-TR-23). Pittsburgh, PA: Software Engineering Institute, Carnegie Mellon University, November 1993.
- [Chen 83] Chen, P. P., ed. *Entity-Relationship Approach to Information Modeling and Analysis*, Amsterdam: North Holland, 1983.
- [Christie 93a] Christie, A.M. "Process-Centered Development Environments: An Exploration of Issues". (CMU/SEI-93-TR-04). Pittsburgh, PA: Software Engineering Institute, Carnegie Mellon University, June 1993.
- [Christie93b] Christie, A.M. "A Graphical Process Definition Language and its Application to a Maintenance Project". *Information and Software Technology*, 35, 6/7, (June/July) 1993: 364-374.
- [Curtis 92] Curtis, B.; Kellner, M.; Over, J. "Process Modeling", *Communications of the ACM*, 35, 9, (September 1992): 75-90.
- [Cusumano 91] Cusumano, M. A. *Japan's Software Factories*, New York: Oxford University Press, 1991.
- [CaseWare] *CaseWare/CM Integration*. Technical note from CaseWare Inc.
- [Dart 91] Dart, S. "Concepts in Configuration Management Systems", *Proceedings of the Third International Conference on Software Configuration Management*, ACM Press, Trondheim, Norway, June, 1991.
- [Dart 94] Dart, S. "Adopting an Automated Configuration Management Solution", *Sixth Annual Software Technology Conference*, Salt Lake City: Paper presented at STC Conference, April 1994.

- [Demiame 92] Demiame, J.C. ed. "Software Process Technology", *Second European Workshop, EWSPT, '92*, Trondheim, Norway: Springer-Verlag, September 1992.
- [Earl 93] Earl, A. "An Introduction to the Notations of ProcessMaker", Mark V Systems, Encino, CA., 1993.
- [Ett 91] Ett, W.H. "Enacting the Software Process", Washington DC: STARS '91 Proceedings, December 1991.
- [Feiler 88] Feiler, P.H., & Smeaton, R. *The Project Management Experiment (CMU/SEI-88-TR-7, ADA197490)*, Pittsburgh, PA: Software Engineering Institute, Carnegie Mellon University, July 1988.
- [Feiler 92] Feiler, P.H.; & Humphrey, W.S. *Software Process Development and Enactment, (CMU/SEI-92-TR-04, ADA258465)*. Pittsburgh, PA: Software Engineering Institute, Carnegie Mellon University, September, 1992.
- [Fletcher 93] Fletcher, T.; & Hunt, J. *Software Engineering and CASE: Bridging the Cultural Gap*, New York: McGraw-Hill Cap Gemini America Series, 1993.
- [Humphrey 89] Humphrey, W. S., "Managing the Software Process", Reading, MA: Addison-Wesley, 1989.
- [Kaiser 90] Kaiser, G.E.; Barghouti, N. S.; & Sokolski, M. H. "Preliminary Experience with Process Modeling in the Marvel Software Development Environment Kernel", *Proceedings of the Twenty-Third Annual Hawaii International Conference on Systems Science*, Vol. 2. IEEE Computer Society Press 1990.
- [Kellner 89] Kellner, M. "Software Process Modeling: Value and Experience", *1989 SEI Technical Review*, Pittsburgh, PA: Software Engineering Institute, Carnegie Mellon University, 1989.
- [Kellner 90] Kellner, M.; & Rombach, H. D. "Comparison of Software Process Descriptions", *Proceedings of the 6th International Software Process Workshop: Support for the Software Process*, Hakodate, Japan: IEEE Computer Society Press, October 1990.
- [Kellner 93a] Kellner, M.; & Gates, L. P. "Evolution of Software Process", *Proceedings of the International Workshop on the Evolution of Software Process*, Quebec, Canada, January, 1993.
- [Kellner 93b] Kellner, M.; & Phillips, R. W. "State of the Practice in Process Technology", *Proceedings of the 8th International Software Process Workshop*, Wadern, Germany: IEEE Computer Society Press, March, 1993.
- [Majkiewicz 94] Majkiewicz, J. "How Smart are Smart Documents", *SunExpert* 5,3 (March 1994): 46-54.

[Mi] Mi, P.; & Scacchi, W. "Process Integration in CASE Environments", *IEEE Software* 9,2 (March 1992): 45-53.

[NIST 93] "Reference Model for Frameworks of Software Engineering Environments, NIST Special Publication 500-211, August, 1993.

[Oaks 92] Oaks, K. S., Smith, D., Morris, E. *Guide to CASE Adoption*, (CMU/SEI-92-TR-15), Pittsburgh, PA: Software Engineering Institute, Carnegie Mellon University, November 1992.

[Osterweil 87] Osterweil, L. "Software Processes are Software Too", *9th International Conference on Software Engineering*, Monterey, California, IEEE Computer Society Press, 1987.

[Page-Jones 92] Page-Jones, M. "The CASE Manifesto", *CASE Outlook*, January-February, 1992: 33-42.

[Paulk 93a] Paulk, M. C., et. al. *Capability Maturity Model for Software, Version 1.1*, (CMU/SEI-93-TR-24, ADA263403), Pittsburgh, PA: Software Engineering Institute, Carnegie Mellon University, February, 1993.

[Paulk 93b] Paulk, M. C.; et al. *Key Practices of the Capability Maturity Model, Version 1.1*, (CMU/SEI-93-TR-25, ADA 263432), Pittsburgh, PA: Software Engineering Institute, Carnegie Mellon University, February, 1993.

[Peuschell 92] Peuschel, B. Schafer, W., Wolf, S. "A knowledge-based Software Development Environment Supporting Cooperative Work", *International Journal of Software Engineering and Knowledge Engineering*, 2,1, (1992): 79-106.

[ProcessWeaver 93] *ProcessWeaver User's Manual and Reference Manual, Version PW1.2*. Grenoble, France: CapGemini Sogeti, 1992.

[Rader 93] Rader, J.; Morris, E.J.; & Brown, A.W. "An Investigation into the State of the Practice of CASE Integration", pp. 209-221. *Proceedings of Software Engineering Environments, '93*, IEEE Computer Society, July 1993.

[Reisig 82] Reisig, W., *Petri Nets*, Heidelberg: Springer-Verlag, 1982.

[Sobell 89] Sobel, M. G. *A Practical Guide to the Unix System, 2nd Edition*, Redwood City, CA: Benjamin Cummings, 1989.

[Soley 92] Soley, R. M., ed. *Object Management Architecture Guide, V2.0*, Object Management Group, September 1992.

[STARS 92] STARS Joint Activity Group. *A Compendium of Process Concepts For Practitioners - PCP Abstracts*, Submitted to Electronic Systems Center, Hanscomb AFB, October 30, 1992.

[SynerVision 93a] SynerVision. *Introduction to SynerVision: Models of Use*, Hewlett-Packard document B3261-90002, Draft May 5, 1993.

[SynerVision 93b] SynerVision. *Developing SynerVision Processes*, Hewlett-Packard document B3261-90003.

[Weiderman 86] Weiderman, N. H.; et al. "A Methodology for Evaluating Environments", pp199-207, *Proceedings of the ACM SIGSOFT/SIGPLAN Software Engineering Symposium on Practical Software Development Environments*, Palo Alto, CA: ACM publication, December 1986.

[Womack 90] Womack, J. P., Jones D. T., Roos, D. *The Machine that Changed the World*, New York,: Rawson Associates, 1990.

[Yourdon 92] Yourdon, E., "The Decline and Fall of the American Programmer", Englewood Cliffs, NJ: Prentice Hall, 1992.

## **Appendix A Vendor Information on PCFs**

The following is a list of products which support process automation for software development or business workflow. This list is not all-inclusive. Configuration management products such as CaseWare and groupware products such as Lotus Notes are also making an impact in the process area. For a review of other products (with a focus on document management) [Majkiewicz 94] should be consulted

### **Life\*Flow**

Company: Computer Resources International A/S

14205 SE 36th St.

Suite 100

Bellevue, WA 98006

Contact: John Wilkerson

Phone: 206-649-1134

Platforms supported: Sun SPARC, IBM RS6000, HP9000, PC Windows (client mode).

### **Process Engineer**

Company: LBMS, Inc.

1040 North Kings Highway

Suite 724

Cherry Hill, NJ 08034

Contact: Joni Fuller

Phone: 609-482-2011

Platforms supported: Networked PCs

### **ProcessWeaver**

Company: Cap Gemini America

1114 Ave. of the Americas

29th floor

New York, NY 10036

Contact: Larry Proctor

Phone (US): 1-800-759-8255 (pin: 513-3640)

Platforms supported: Unix platforms including HP, Dec, Sun SPARC, IBM RS6000. The Agenda (client mode) also runs under MicroSoft Windows.

**ProcessWise**

**Company: ICL**

**ProcessWise Portfolio Center**

**ICL Waterside Park**

**Cain Road**

**Bracknell, Berkshire, RG12 1FA**

**United Kingdom**

**Contact: Jane Burns**

**Phone (UK): 44-0344-711795**

**Platforms supported: ICL DRS6000, ICL Series 39, Sun, Bull DPX20, IBM RS6000**

**SynerVision**

**Company: Hewlett-Packard Company**

**Software Engineering Systems Division**

**3404 East Harmony St., MS 7**

**Fort Collins, Colorado 80525**

**Contact: Dave Pugmire, Process Program Manager**

**Phone: 303-229-3265**

**Platforms supported: HP9000. Sun SPARC platforms should be supported by the time this report is released.**

## Appendix B Listing of SynerVision Experiment Script

The following script is for the SynerVision implementation of the experimental model. It is provided a) to illustrate the programming that was required to implement the model and b) as a basis for others who may wish to explore SynerVision's capabilities. Each *AUTOMATIC\_ACTION* in the script corresponds to one of the activities in the task hierarchy shown at the beginning of the script. Also provided at the end of the script is a listing of the function *getTerm* that is used in the process model. Clearly the script needs to be modified to be used on other machines, as path names will be different. In addition, the variables *manager*, *person1*, etc., instantiated in the first *AUTOMATIC\_ACTION*, need to be defined in SynerVision's *schema* file.

ProcessWeaver defines its graphical model as a series of ASCII files. While these are readable, they are machine-generated, quite lengthy, and thus not provided.

```
# This is the task hierarchy for the Update Document project
*****
```

```
TASK "Initiate Project"
InitProj=$last_TASKID
```

```
CHILDREN_BEGIN
```

```
    TASK "Review New CR"
    RevNewCR=$last_TASKID
```

```
    TASK "Identify Agents For Roles"
    IdenAgForRl=$last_TASKID
```

```
        CHILDREN_BEGIN
```

```
            TASK "Make Revised Assignments"
            ReviseAssign=$last_TASKID
```

```
            TASK "Impose Assignments"
            ImposeAssign=$last_TASKID
```

```
            TASK "Get Editors Reply"
            GetEdReply=$last_TASKID
```

```
            TASK "Notify Editor"
            NotifyEd=$last_TASKID
```

```
            TASK "Notify Reviewer"
            NotifyRev=$last_TASKID
```

```
            TASK "Check If Person A is Editor"
            CheckA=$last_TASKID
```

```
            TASK "Make Initial Assignments"
            InitAssign=$last_TASKID
```

```
        CHILDREN_END
```

```
    TASK "Update Document"
    UpdateDoc=$last_TASKID
```

```
        CHILDREN_BEGIN
```

```
            TASK "Get Report"
            GetReport=$last_TASKID
```

```
            TASK "Initial Mods"
            InitMod=$last_TASKID
```

```

TASK "Modify Report"
ModReport=$last_TASKID

TASK "Review Report"
RevReport=$last_TASKID

TASK "Put Report"
PutReport=$last_TASKID

CHILDREN_END

CHILDREN_END

# Each AUTOMATIC_ACTION below is associated with one of the tasks above
#####

AUTOMATIC_ACTION -t $InitProj Status New Inprogress perform <<EOF
# Initialize the variables for the project
ATTRIB -i -v manager "Paul"
ATTRIB -i -v person1 "Leonard"
ATTRIB -i -v person2 "Alan"
ATTRIB -i -v report "TestReport"
ATTRIB -i -v CR "CR_No_1"
ATTRIB -i -v notes "ReviewNotes"
ATTRIB -i -v inc 0
ATTRIB -i -v -t $RevNewCR "Executing=Running_Foreground"
EOF

AUTOMATIC_ACTION -t $RevNewCR Status New Inprogress perform <<EOF
# Send a message to the manager requesting him to decide on the acceptability of the
# modification. If the modification is unacceptable, the project terminates here.
CR=`GET_ATTRIB CR`
report=`GET_ATTRIB report`
manager=`GET_ATTRIB manager`
display=`getTerm $manager`
DISPLAY=$display
export DISPLAY
cd /users/amc/SVdata
get -e s.\$report>temp
chmod a-w \$report
emacs \$CR &
emacs \$report &
result=`svprompt -p "\$manager, please review the acceptability of change request \$CR
per the document \$report then press either the Accept or Reject button" -L -d "Accept
Reject"`
# mark this task completed
ATTRIB -i -v -t $RevNewCR "Status=Completed"
if [ \$result = "Accept" ]; then
# start the next task
ATTRIB -i -v -t $IdenAgForRl "Executing=Running_Foreground"
else
# mark parent task as abandoned
ATTRIB -i -v -t $InitProj "Status=Abandoned"
fi
delta s.\$report>temp
EOF

AUTOMATIC_ACTION -t $IdenAgForRl Status New Inprogress perform <<EOF
# This task is for continuity -- it has no action except to call to a lower-level task
ATTRIB -i -v -t $InitAssign "Executing=Running_Foreground"
EOF

AUTOMATIC_ACTION -t $UpdateDoc Status New Inprogress perform <<EOF
# This task is for continuity -- it has no action except to call to a lower-level task
ATTRIB -i -v -t $GetReport "Executing=Running_Foreground"
EOF

AUTOMATIC_ACTION -t $InitAssign Status New Inprogress perform <<EOF
# The manager makes an initial assignment of the proposed editor, and by default, also the
# reviewer.
report=`GET_ATTRIB report`
manager=`GET_ATTRIB manager`
personA=`GET_ATTRIB person1`
personB=`GET_ATTRIB person2`
display=`getTerm $manager`
DISPLAY=$display
assign=`svprompt -p "\$manager, please make an initial assignment of who
will edit the report \$report" -L -d "\$personA
\$personB"`
if [ \$assign = \$personA ]; then
ATTRIB -i -v -t $InitProj editor \$personA

```

```

        ATTRIB -i -v -t $InitProj reviewer \ $personB
    else
        ATTRIB -i -v -t $InitProj editor \ $personB
        ATTRIB -i -v -t $InitProj reviewer \ $personA
    fi
    ATTRIB -i -v -t $InitAssign "Status=Completed"
    ATTRIB -i -v -t $GetEdReply "Executing=Running_Foreground"
EOF

```

```

AUTOMATIC_ACTION -t $ReviseAssign Status New Inprogress perform <<EOF
# As a result of the first person refusing the editor role, the second person is chosen to be
# the editor.
    personA=\`GET_ATTRIB reviewer\`
    personB=\`GET_ATTRIB editor\`
    ATTRIB -i -v -t $InitProj editor \ $personA
    ATTRIB -i -v -t $InitProj reviewer \ $personB
    ATTRIB -i -v -t $ReviseAssign "Status=Completed"
    ATTRIB -i -v -t $CheckA "Status=New"
    ATTRIB -i -v -t $GetEdReply "Status=New"
    ATTRIB -i -v -t $GetEdReply "Executing=Running_Foreground"
EOF

```

```

AUTOMATIC_ACTION -t $ImposeAssign Status New Inprogress perform <<EOF
# As a result of the second person refusing the editor role, the manager must decide who will be
# the editor (and then by default, who will be reviewer).
    manager=\`GET_ATTRIB manager\`
    personA=\`GET_ATTRIB person1\`
    personB=\`GET_ATTRIB person2\`
    display=\`getTerm \ $manager\`
    DISPLAY=\$display
    assign=\`svprompt -p "\ $manager, both staff members have refused the editing assignment.
Please assign either \ $personA or \ $personB to be editor" -L -d "\ $personA
\ $personB"\`
    if [ \ $assign = \ $personA ]; then
        ATTRIB -i -v -t $InitProj editor \ $personA
        ATTRIB -i -v -t $InitProj reviewer \ $personB
    else
        ATTRIB -i -v -t $InitProj editor \ $personB
        ATTRIB -i -v -t $InitProj reviewer \ $personA
    fi
    ATTRIB -i -v -t $NotifyEd "Executing=Running_Foreground"
    ATTRIB -i -v -t $NotifyRev "Executing=Running_Foreground"
    ATTRIB -i -v -t $ImposeAssign "Status=Completed"
EOF

```

```

AUTOMATIC_ACTION -t $NotifyEd Status New Inprogress perform <<EOF
# The person selected to be editor is notified of the manager's choice.
    report=\`GET_ATTRIB report\`
    personA=\`GET_ATTRIB editor\`
    display=\`getTerm \ $personA\`
    DISPLAY=\$display
    svprompt -p "\ $personA, you have been selected to be editor for report \ $report"
    ATTRIB -i -v -t $NotifyEd "Status=Completed"
EOF

```

```

AUTOMATIC_ACTION -t $NotifyRev Status New Inprogress perform <<EOF
# The person selected to be reviewer is notified of the manager's choice.
    report=\`GET_ATTRIB report\`
    personB=\`GET_ATTRIB reviewer\`
    display=\`getTerm \ $personB\`
    DISPLAY=\$display
    svprompt -p "\ $personB, you have been selected to be reviewer for report \ $report"
    ATTRIB -i -v -t $UpdateDoc "Executing=Running_Foreground"
    ATTRIB -i -v -t $NotifyRev "Status=Completed"
    ATTRIB -i -v -t $IdenAgForRl "Status=Completed"
EOF

```

```

AUTOMATIC_ACTION -t $CheckA Status New Inprogress perform <<EOF
# Select path to next task depending on whether this is the first of second request for a
# volunteer to be editor.
    report=\`GET_ATTRIB report\`
    reviewer=\`GET_ATTRIB reviewer\`
    inc=\`GET_ATTRIB inc\`
    personA=\`GET_ATTRIB editor\`
    display=\`getTerm \ $personA\`
    DISPLAY=\$display
    if [ \ $inc = 0 ]; then
        ATTRIB -i -v -t $InitProj inc 1
        reviewer=\`GET_ATTRIB reviewer\`
        svprompt -p "I will check to see if \ $reviewer will be editor"
        ATTRIB -i -v -t $ReviseAssign "Executing=Running_Foreground"
    fi

```

```

else
    manager=\`GET_ATTRIB manager\`
    reportA=\`GET_ATTRIB report\`
    svprompt -p "\$manager will have to decide who will update \$report"
    ATTRIB -i -v -t \$ImposeAssign "Executing=Running_Foreground"
fi
ATTRIB -i -v -t \$CheckA "Status=Completed"
EOF

AUTOMATIC_ACTION -t \$GetEdReply Status New Inprogress perform <<EOF
# Send message asking if person will volunteer to be editor. Depending on the result, select
# appropriate next task.
CR=\`GET_ATTRIB CR\`
report=\`GET_ATTRIB report\`
personA=\`GET_ATTRIB editor\`
reportA=\`GET_ATTRIB report\`
display=\`getTerm \$personA\`
DISPLAY=\$display
reply=\`svprompt -p "\$personA are you willing to act as editor for \$report
per the change request \$CR" -L -d "accept
reject"\`
if [ \$reply = "accept" ]; then
    ATTRIB -i -v -t \$NotifyRev "Executing=Running_Foreground"
else
    ATTRIB -i -v -t \$CheckA "Executing=Running_Foreground"
fi
ATTRIB -i -v -t \$GetEdReply "Status=Completed"
EOF

AUTOMATIC_ACTION -t \$GetReport Status New Inprogress perform <<EOF
# Retrieve report form repository.
report=\`GET_ATTRIB report\`
CR=\`GET_ATTRIB CR\`
cd /users/amc/SVdata
get -e s.\$report>temp
chmod a-w \$CR
ATTRIB -i -v -t \$InitMod "Executing=Running_Foreground"
ATTRIB -i -v -t \$GetReport "Status=Completed"
EOF

AUTOMATIC_ACTION -t \$InitMod Status New Inprogress perform <<EOF
# Request the the editor updates the document as requested in the change request.
editor=\`GET_ATTRIB editor\`
report=\`GET_ATTRIB report\`
CR=\`GET_ATTRIB CR\`
display=\`getTerm \$editor\`
DISPLAY=\$display
export DISPLAY
cd /users/amc/SVdata
chmod a+w \$report
emacs \$report &
emacs \$CR &
svprompt -p "\$editor, please update \$report, as
requested in the chnage request \$CR. When you are fininshed,
press the OK button"
ATTRIB -i -v -t \$RevReport "Executing=Running_Foreground"
ATTRIB -i -v -t \$InitMod "Status=Completed"
EOF

AUTOMATIC_ACTION -t \$ModReport Status New Inprogress perform <<EOF
# A a result of the document review, the document still needs revision. The editor is requested
# to make these revisions.
editor=\`GET_ATTRIB editor\`
report=\`GET_ATTRIB report\`
CR=\`GET_ATTRIB CR\`
ReviewNotes=\`GET_ATTRIB notes\`
display=\`getTerm \$editor\`
DISPLAY=\$display
export DISPLAY
cd /users/amc/SVdata
chmod a+w \$report
emacs \$report &
emacs \$CR &
chmod a-w \$ReviewNotes
emacs \$ReviewNotes &
svprompt -p "\$editor, unfortunately your revisions to \$report did not pass review.
Please modify the document as indicated by the comments in \$ReviewNotes.
When you are finished, press the OK button."
ATTRIB -i -v -t \$RevReport "Status=New"
ATTRIB -i -v -t \$RevReport "Executing=Running_Foreground"
ATTRIB -i -v -t \$ModReport "Status=Completed"

```

EOF

```
AUTOMATIC_ACTION -t $RevReport Status New Inprogress perform <<EOF
# The reviewer checks the revised document against the change request. This can result in the
# document passing or the review or requiring further work.
reviewer=\`GET_ATTRIB reviewer\`
report=\`GET_ATTRIB report\`
CR=\`GET_ATTRIB CR\`
ReviewNotes=\`GET_ATTRIB notes\`
display=\`getTerm \$reviewer\`
DISPLAY=\$display
export DISPLAY
cd /users/amc/SVdata
chmod a-w \$report
emacs \$report &
emacs \$CR &
chmod a+w \$ReviewNotes
emacs \$ReviewNotes &
reply=\`svprompt -p "\$reviewer, please review this updated version of \$report,
using the change request \$CR, and comments in \$ReviewNotes. Any additional comments
should also go into \$ReviewNotes." -L -d "DocOK
NeedsFurtherWork"\`
if [ \$reply = "DocOK" ]; then
  chmod a-w \$ReviewNotes
  ATTRIB -i -v -t $PutReport "Executing=Running_Foreground"
else
  ATTRIB -i -v -t $ModReport "Status=New"
  ATTRIB -i -v -t $ModReport "Executing=Running_Foreground"
fi
ATTRIB -i -v -t $RevReport "Status=Completed"
EOF
```

```
AUTOMATIC_ACTION -t $PutReport Status New Inprogress perform <<EOF
# The updated document is saved in the repository and the manager is informed of completion of
# the project
manager=\`GET_ATTRIB manager\`
report=\`GET_ATTRIB report\`
display=\`getTerm $manager\`
cd /users/amc/SVdata
delta s.\$report>temp
DISPLAY=\$display
svprompt -p "\$manager, the report \$report has been successfully updated"
ATTRIB -i -v -t $UpdateDoc "Status=Completed"
ATTRIB -i -v -t $InitProj "Status=Completed"
EOF
```

The following is a listing of the function getTerm used in the above script.

```
#Given a user's name, return the display they use
user_name=$1
( grep $user_name | awk -F/t '{print $3}' ) <<EOF

Proper Name Login Display
-----
Alan Christie amc bs
Paul Zarella pfz ncdays:0.0
Leonard Green lsg ncdays:0.0

EOF
```



## Appendix C A Brief Overview of ProNet

To understand the process diagrams of Section 3, this section provides a brief guide to the ProNet notation. ProNet diagrams are based on a modified Entity-Relation model [Chen], in which the entities fall into one of eight classes. The following list defines the entity classes used in an enactable model, and shows the symbols associated with each entity class<sup>12</sup>:



• **Activities** - are central elements of the process model and both consume artifacts or conditions (as inputs) and generate artifacts or conditions (as outputs). Activities may be atomic or may be composed of subprocesses.

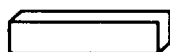

• **Artifacts**<sup>13</sup> - can either be required to support an activity or be produced by an activity.



• **Conditions** - can either be required to initiate an activity or result from an activity and take the values TRUE or FALSE.



• **Agents** - are specific entities that perform activities. Humans or non-human entities capable of performing activities are considered to be agents.



• **Composites** - are boolean combinations of conditions, artifacts, agents, etc.



• **Stores** - allow for persistence of instantiated entities. Artifacts, condition values, and even agents can be deposited in or retrieved from stores.

Relationships link the entities to the activities. Thus relationships are of the form:

{artifact} *is entrance artifact for* {activity}

{activity} *has exit artifact* {artifact}

{agent} *is entrance agent for* {activity}

Artifacts, conditions, agents and stores may have unknown values at the time the process is defined. For these entities, a "\$" sign is placed in front of the entity's name. These entities will need to have their value instantiated at execution time<sup>14</sup>.

In the process diagrams, these relationships allow the reader to identify the class of entity that is linked to the activity. Also, if the relationship "artifact\_1 *is entrance artifact for* activity\_1" holds, so does the inverse relationship "activity\_1 *has entrance artifact* artifact\_1". A black dot

<sup>12</sup> The set of graphical symbols defined here is expanded over the set used in [Christie 93a].

<sup>13</sup> The term "product", which was used in the initial version of ProNet, has been replaced by the term "artifact."

<sup>14</sup> In the initial version of ProNet [Christie 93a, Christie 93b] the convention of prefixing entities with a "\$" was not used. In that initial version, the entity classes "agent" and "role" were defined separately. Placing a "\$" sign in front of an agent's name implies that the agent is unspecified prior to run-time. This is equivalent to the previous notion of a role, and hence there is no longer a need for the "role" class.

is placed next to the entity at the end of the relationship. For example in the relationship "ABC is entrance artifact for XYZ", the dot would appear in the graphical relationship close to the box surrounding the activity XYZ.

## C.1 Hierarchical Decomposition

Activities can be processes in their own right. Thus an activity at one level can be expanded into a process diagram at a lower level. For consistency, inputs to and outputs from an activity must propagate through to the lower-level process that it represents. Thus consistency of information at the interface between levels is maintained.

To illustrate these points, examine Figures 3-2 and 3-3. The activity *Identify Agents or Roles* in Figure 3-2 has its elements defined by the process diagram in Figure 3-3. As can be seen, inputs to the process diagram are attached to the left-hand edge of the diagram, while outputs from that process are attached to the right-hand edge of the diagram.

## C.2 Composites, Versions, and Stores

An important concept in the basic notation is the composite class. Composites allow boolean combinations of entities to be logically related, either as input to an activity or as the output from an activity. There are four instances of the composite class: CA, CO, DA, and DO, where "C" stands for "convergent", "D" stands for "divergent", "A" stands for "AND", and "O" stands for "OR". Since convergent composites are always implemented prior to an activity they are called "entrance composites". Similarly, since divergent composites are always implemented after an activity they are called "exit composites".

Iteration is required when, for example, an artifact undergoes a series of revisions, each revision being different from the last and thus requires looping around a sequence of process steps. Consider an artifact (*prod*) that is initially created, at which time an incrementing variable is set to an initial value (*create\_prod | i=1*). Each time the artifact is updated in the activity *update\_prod*, the variable is also incremented (*update\_prod | i++*). Versions of artifacts are tagged with the variable *i*, and hence versions of the artifact are defined. Thus *prod | i* represents the *i*'th version of the artifact. Nested loops can also be implemented using this notation.

Stores support collections of artifacts and conditions values, and thus allow for modeling of persistency of generated entities. Since we must be able to add these entities to or retrieve these entities from a store, we introduce two special activities. These do not generate artifacts, conditions, etc., but add artifacts to and remove artifacts from a store. The activity types (*put*, *get*) are illustrated in Figure C-1 and are added on to the front of the activity name as shown in the Figure C-1.

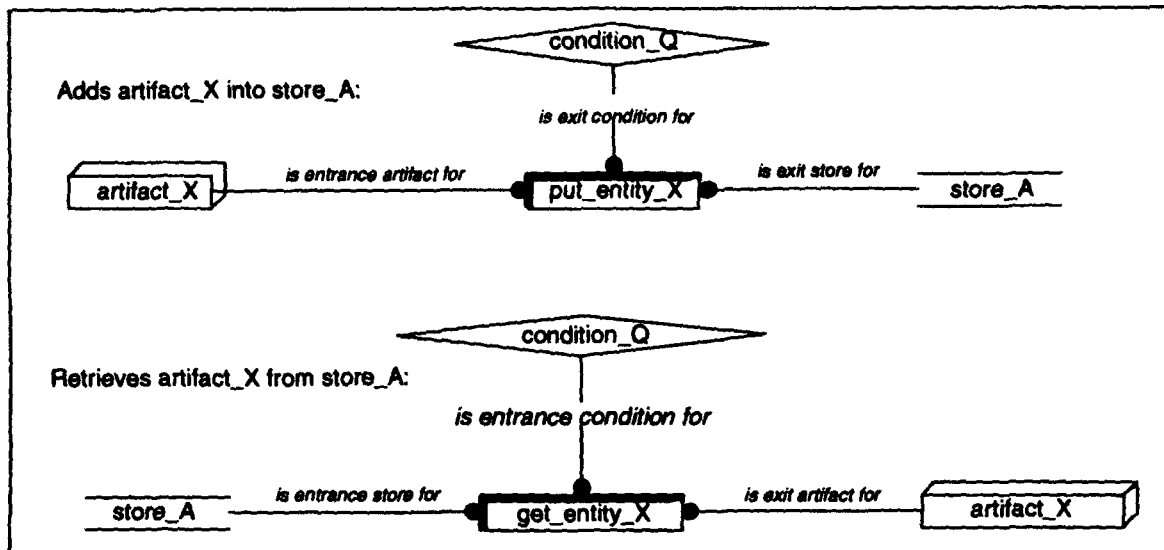

Figure C-1: Definition of Activities Associated Only with "Store" Entities

### C.3 An Example of a Simple ProNet Model

Figure C-2 illustrates a simple ProNet model fragment. A change request (CR) is initialized at which time the incrementing variable is set to an initial value (*initialize CR | i=1*). The output from that activity is the first version of the change request (*CR | 1*). The composite (CO) accepts either the first or subsequent versions of the change request as input to the activity *review CR*. Output from *review CR* can either be the condition *CR OK* or the artifact *revision request | i*. Each time the change request is updated, the variable *i* is incremented (*update CR | i++*). Note that each activity is supported by an agent.

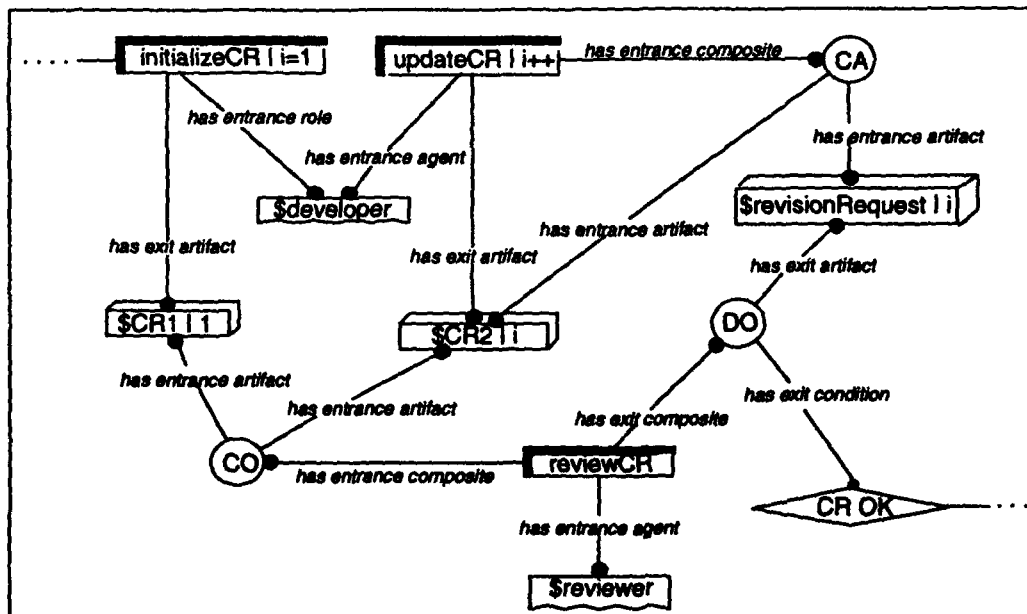

Figure C-2: Simple ProNet Change Request Model



## Appendix D Terminology and Concepts

This appendix provides an overview of some of the process-related terminology and concepts used in the body of the report. Definitions of basic terms have been extracted from [Feiler 92] and are used with the same meaning as in that document. However, there are other terms used in the report which need to be explained more fully, since these terms have not gained general acceptance. This appendix also relates some of the process entities examined to the process categories defined in [NIST 93]. [Osterweil 87] also provides a good explanation of concepts in this area.

### D.1 Basic Terminology

Some basic process-related definitions, extracted from [Feiler 92] are given below.

**Process:**

*A set of partially ordered steps intended to reach a goal.* While the term process is used in many different contexts, the context for this definition is software. For software development, the goal is production or enhancement of software products or the provision of services. Other examples are the software maintenance process, the acceptance testing process, or the process development process.

**Process automation:**

*The use of machine process agents in process enactment.* Here the use of the machine agent is facilitated by a fully-developed process definition embodied in a suitable process program.

In the report, this term process automation is also used in a more general sense. It is used when dealing with the broader organizational context in which the process-centered framework implemented (as in the title of the report).

**Process definition:**

*The implementation of a process design in the form of a partially ordered set of process steps that is enactable.* At the lower end abstraction, each process step may be further refined into more detailed process steps. A process definition may consist of (sub)process definitions that can be enacted concurrently. Process definitions whose level of abstraction are refined fully are referred to as complete or fit for enactment. Completeness, however, depends on context since a definition that is complete for one process agent may not be for another. A process definition may be for a class of projects, a specific project team, or an individual professional.

**Enactable process:**

*An instance of a process definition that includes all the elements required for enactment. An enactable process consists of a process definition, required process inputs, assigned enactment agents and resources, an initial enactment state, an initial enactment agent and continuation and termination capabilities. A process that lacks any of these capabilities is not enactable.*

**Process model:**

*An abstract representation of a process architecture, design, or definition. Process models are process elements at the architectural, design, or definitions level, whose abstraction captures those elements of a process relevant to the modeling. Any representation of the process is a process model. Process models are used where use of the complete process is undesirable or impractical. A process model can be analyzed, validated and, if enacted, can simulate the modelled process. Process models may be used to assist in process analysis, to aid in process understanding, or to predict process behavior.*

The process example referred to in the report (and in Figure D-1) is an instance of a process model for a specific application, and described using a graphical process notation (ProNet).

**Process program:**

*A process definition which is suitably designed and instantiated for enactment by machine. Process programs must be designed to fit the particular computing environmental needs for format and generally be tested, debugged, and modified much like computer programs*

## **D.2 Process-Related Concepts**

Two related concepts are used throughout this report: process-centered framework (PCF) and process-centered environment (PCE). These terms are defined below and their relationships to other process terms are illustrated through the Entity-Relation model of Figure D-1. These definitions attempt to capture the spirit of the concepts *framework* and *environment* as defined in [Brown 93b]. We also introduce below the term *process template*.

**Process centered framework (PCF):**

*A PCF is a software product which provides the functionality necessary for the definition and enactment of process. It includes a process enactment language, mechanisms for process enactment, a means to invoke tools, support for communications (between persons and tools), and capabilities to support the debugging the process models described within the process enactment language.*



### Process-centered environment (PCE):

A PCE is a software product which includes the facilities of a PCF, and also includes application tools. Examples of applications that these tools may support are: metrics collection, project management, and software development.

### Process template:

A process template is a process program in which the variables have not been instantiated.

Both a PCF and a PCE must have certain basic functionality, such as a supporting a process programming language, while only a PCE will have an end-user application as part of the product. ProcessWeaver (V1.2) is clearly a PCF since it does not have any application tools embedded in it. On the other hand SynerVision may be considered to be a PCE since it has some end-user applications embedded in it. Either a PCF or a PCE can invoke end-user application tools to support a particular process and this can be seen in the figure.

## D.3 Relationship to the NIST/ECMA Reference Model

The report *Reference Model for Frameworks of Software Engineering Environments* [NIST 93] defines a conceptual model which is relevant to the discussions in this appendix. It partitions services needed by a Software Engineering Environment into seven categories. The sixth category, *process management*, is then structured into six process-related services: *development*, *enactment*, *visibility*, *monitoring*, *transaction*, and *resource*. The [NIST 93] process management categories are similar to those described in Table 3-1 (i.e., *development*, *enactment*, *debugging*, *resource*, and *communication*), which were found to be a useful set of categories in the investigations of SynerVision and ProcessWeaver. A new category, not found in the [NIST 93] model, is *debugging*, while the NIST model defined the category *transaction* which was not needed since neither SynerVision nor ProcessWeaver had mechanisms to support the concept. The NIST category of *monitoring* is similar to the categories of *communication*. A correlation between the NIST process service categories and the elements of Table 3-1 is shown in Table D-1.

**Table D-1: Relationship to NIST Service Categories**

[NIST] Service <sup>a</sup>	Item Numbers from Table 3-1
development	1b, 1c, 1d, 1e, 1f, 1g
enactment	2a, 2b, 2c
visibility	1a
monitoring	4a, 4b
transaction	3b <sup>b</sup>
resource	3a

a. Debugging services are not covered in [NIST].

b. Neither SynerVision nor ProcessWeaver supports transaction services.

## Appendix E End-User Evaluation Materials

**Objective:** To evaluate the effectiveness end-user interface capability provided by SynerVision and Processweaver. Note that the objective is *not* to evaluate the process model itself or its implementations in the products. To this end, the two implementations have been kept as similar as possible.

In order to consider this evaluation of ProcessWeaver and Synervision from an end-user perspective, you are asked to participate in an exercise in which you will act out one of three roles in a simple document update scenario. This scenario, as defined in Figures 3-2 through 3-4, will be enacted twice, once using a process model which has been implemented with ProcessWeaver, and once in a model implemented with SynerVision. You will then be asked to answer some questions about the two versions of the scenario and also about process automation in general.

The scenario deals with updating a document. There are three roles; a manager and two technical writers. Also, there are three documents: the *document* to be modified, the *change request* that contains the modifications to be made, and *review notes* that contain any information which the document reviewer may wish to send to the editor. There are four tasks in the exercise which are:

- to determine if the change request should be implemented (manager's task).
- to select one of the two technical writers as editor and the other as reviewer (manager's task). The sequence of events is as follows. The manager suggests that the first writer be the editor. If the first writer rejects the role, the second writer is automatically asked to be the editor. If the second writer also refuses the role, the manager then dictates which writer will be editor. By default, the other writer becomes reviewer.
- to update the document (editor's task).
- to review and either accept or reject the revisions (reviewer's task). If a review fails, then the document, the change request and a review notes document (in which the reviewer adds review notes) goes back to the editor. The edit/review cycle continues until the reviewer is satisfied.

In the scenario, many of the administrative tasks (e.g., making sure that the right persons have the right documents at the right times) are automated. The information in Table E-1 provides you with the guidance necessary to follow the scenario. The actions in this table are all sequential. If you are given the role of *Technical Writer A*, then follow the instructions for that role. When an action needs to be performed, guidance is displayed at the terminal of the appropriate person, along with the documents necessary to perform the action.

After performing the scenario, please answer the questions in Table E-2 as fully as possible. Answers to some of these questions may require technical and human insights which stretch the limited scope of the simple scenario. Therefore, please use your own background experience in conjunction with knowledge gained in the role play to answer the questions.

**Table E-2: Process Enactment Scenario**

#	Role	Action
1	Manager	a) Review the change request <i>CR_No_1</i> with respect to document <i>TestReport</i> . b) Close both documents (control-x control-c). c) Accept the change request by clicking on <i>accept</i> button.
2	Manager	Select Technical Writer A as editor by clicking on button beside <i>Technical Writer A</i> .
3	Technical Writer A	Reject role as editor, by clicking on <i>reject</i> button.
4	Technical Writer A	Remove the information window by clicking on the OK button.
5	Technical Writer B	Reject role as editor by clicking on <i>reject</i> button.
6	Technical Writer B	Remove the information window by clicking on the OK button.
7	Manager	Force selection of <i>Technical Writer A</i> as editor by clicking on button beside <i>Technical Writer A</i> .
8	Technical Writer A	Remove the information window by clicking on the OK button.
9	Technical Writer B	Remove the information window by clicking on the OK button.
10	Technical Writer A	a) Modify the document <i>TestReport</i> as described in <i>CR_No_1</i> . b) Save the updated <i>TestReport</i> file (control-x control-s). c) Close both documents (control-x control-c). d) Click on the OK button.
11	Technical Writer B	a) Review the document <i>TestReport</i> against the modifications in <i>CR_No_1</i> . b) In the <i>ReviewNotes</i> document add "Replace last period ('.') in report with an exclamation point ('!')". c) Save the updated <i>ReviewNotes</i> file (control-x control-s). d) Close all documents (control-x control-c). e) Click on the <i>NeedsFurtherWork</i> button.
12	Technical Writer A	a) Modify the document <i>TestReport</i> as described in <i>ReviewNotes</i> . b) Save the updated <i>TestReport</i> file (control-x control-s). c) Close all documents (control-x control-s). d) Click on the <i>OK</i> button.
13	Technical Writer B	a) Review the document <i>TestReport</i> against the modifications in <i>ReviewNotes</i> and in the change request. b) Close all documents (control-x control-c). c) Accept review by clicking on the <i>DocOK</i> button.
14	Manager	Click on the OK button.

**Table E-3: Questionnaire for End-User Role Plays<sup>a</sup>**

<b>A. Experience with the scenario (ProcessWeaver)</b>						
1	The screen layouts were easy to understand.	1	2	3	4	5
2	The instructional text was well formatted.	1	2	3	4	5
3	The instructional text was easy to read.	1	2	3	4	5
4	The Agenda window was useful in displaying current tasks.	1	2	3	4	5
5	The use of icons was helpful in organizing the task elements.	1	2	3	4	5
6	The use of buttons was effective.	1	2	3	4	5
7	The amount of information in the windows was good.	1	2	3	4	5
8	Computer response times were good.	1	2	3	4	5
9	I found it easy to understand the operating mechanics of the system.	1	2	3	4	5
10	The guided task sequence was helpful in managing the process.	1	2	3	4	5
11	The task sequencing was logical.	1	2	3	4	5
12	I would enjoy working in an environment supported by ProcessWeaver.	1	2	3	4	5
<b>B. Experience with the scenario (SynerVision)</b>						
1	The screen layouts were easy to understand.	1	2	3	4	5
2	The instructional text was well formatted.	1	2	3	4	5
3	The instructional text was easy to read.	1	2	3	4	5
4	The use of buttons was effective.	1	2	3	4	5
5	The amount of information in the windows was good.	1	2	3	4	5
6	Computer response times were good.	1	2	3	4	5
7	I found it easy to understand the operating mechanics of the system.	1	2	3	4	5
8	The guided task sequence was helpful in managing the process.	1	2	3	4	5
9	The task sequencing was logical.	1	2	3	4	5
10	I would enjoy working in an environment supported by SynerVision.	1	2	3	4	5

Please add any comments here.

a. In ranking your answers, 1 implies total disagreement, 5 represents full agreement.

**Table E-2: Questionnaire for End-User Role Plays (cont.)**

<b>C. Adoption issues</b>	
Given your brief experience with the process automation scenario, would you feel comfortable working in a process-centered environment if:	
1) it were designed by you and only supported your personal tasks,	<input type="checkbox"/> 1 <input type="checkbox"/> 2 <input type="checkbox"/> 3 <input type="checkbox"/> 4 <input type="checkbox"/> 5
2) you had input to its design, and it were used within your project,	<input type="checkbox"/> 1 <input type="checkbox"/> 2 <input type="checkbox"/> 3 <input type="checkbox"/> 4 <input type="checkbox"/> 5
3) it were predefined, but modified (with your input) for use within your project,	<input type="checkbox"/> 1 <input type="checkbox"/> 2 <input type="checkbox"/> 3 <input type="checkbox"/> 4 <input type="checkbox"/> 5
4) you did not have input to its design?	<input type="checkbox"/> 1 <input type="checkbox"/> 2 <input type="checkbox"/> 3 <input type="checkbox"/> 4 <input type="checkbox"/> 5
Please explain your reasons.	
Do you think that working within a process-centered environment is <i>necessarily</i> :	
1) too invasive,	<input type="checkbox"/> 1 <input type="checkbox"/> 2 <input type="checkbox"/> 3 <input type="checkbox"/> 4 <input type="checkbox"/> 5
2) too impersonal	<input type="checkbox"/> 1 <input type="checkbox"/> 2 <input type="checkbox"/> 3 <input type="checkbox"/> 4 <input type="checkbox"/> 5
3) too controlling?	<input type="checkbox"/> 1 <input type="checkbox"/> 2 <input type="checkbox"/> 3 <input type="checkbox"/> 4 <input type="checkbox"/> 5
Please explain your reasons.	





## Acknowledgments

I'd like to thank Mike Baumann of Hewlett Packard, and Jean-Luc Meunier and Larry Proctor of Cap Gemini for all their support and patience while I developed the process models. Without their help, I could not have performed the in-depth analysis that I did. In particular I would like to thank Mike Baumann for helping develop parts of the process script and the supporting function *getTerm* and to thank Jean-Luc Meunier for helping to develop parts of the ProcessWeaver model and supporting SCCS functions. I'd also like to thank Granville Gosa and Paul Zarella whose local technical support was invaluable. I'd like to thank Christer Fernstrom, Jean-Luc Meunier and Gerald Perdreau of Cap Gemini for their technical review of the ProcessWeaver sections of the report and to thank Dave Pugmire of Hewlett Packard for his review of the Synervision section. I'd also like to thank Edward Averill, Alan Brown, David Carney, Marc Kellner Leonard Green, and Patricia Oberndorf for the wealth of excellent suggestions they gave me from their reviews. These have significantly improved the quality of the document. I appreciate the support of those who participated in the end-user evaluations and who provided me the excellent insights which resulted from that experience (Jim Armitage, Edward Averill, Cliff Huff, Ed Morris, Neal Reizer, and Paul Zarella). Finally, I'd like to thank Julia Deems and Sandra Bond for their copy-editing of the final draft. Of course, I take full responsibility for any remaining errors in the report.



## REPORT DOCUMENTATION PAGE

<b>1a. REPORT SECURITY CLASSIFICATION</b> Unclassified		<b>1b. RESTRICTIVE MARKINGS</b> None													
<b>2a. SECURITY CLASSIFICATION AUTHORITY</b> N/A		<b>3. DISTRIBUTION/AVAILABILITY OF REPORT</b> Approved for Public Release Distribution Unlimited													
<b>2b. DECLASSIFICATION/DOWNGRADING SCHEDULE</b> N/A															
<b>4. PERFORMING ORGANIZATION REPORT NUMBER(S)</b> CMU/SEI-94-TR-007		<b>5. MONITORING ORGANIZATION REPORT NUMBER(S)</b> ESC-TR-94-007													
<b>6a. NAME OF PERFORMING ORGANIZATION</b> Software Engineering Institute	<b>6b. OFFICE SYMBOL (if applicable)</b> SEI	<b>7a. NAME OF MONITORING ORGANIZATION</b> SEI Joint Program Office													
<b>6c. ADDRESS (city, state, and zip code)</b> Carnegie Mellon University Pittsburgh PA 15213		<b>7b. ADDRESS (city, state, and zip code)</b> HQ ESC/ENS 5 Eglin Street Hanscom AFB, MA 01731-2116													
<b>8a. NAME OFFUNDING/SPONSORING ORGANIZATION</b> SEI Joint Program Office	<b>8b. OFFICE SYMBOL (if applicable)</b> ESC/ENS	<b>9. PROCUREMENT INSTRUMENT IDENTIFICATION NUMBER</b> F1962890C0003													
<b>8c. ADDRESS (city, state, and zip code)</b> Carnegie Mellon University Pittsburgh PA 15213		<b>10. SOURCE OF FUNDING NOS.</b> <table border="1" style="width: 100%; border-collapse: collapse; margin-top: 5px;"> <tr> <td style="width: 25%;">PROGRAM ELEMENT NO</td> <td style="width: 25%;">PROJECT NO.</td> <td style="width: 25%;">TASK NO</td> <td style="width: 25%;">WORK UNIT NO.</td> </tr> <tr> <td>63756E</td> <td>N/A</td> <td>N/A</td> <td>N/A</td> </tr> </table>		PROGRAM ELEMENT NO	PROJECT NO.	TASK NO	WORK UNIT NO.	63756E	N/A	N/A	N/A				
PROGRAM ELEMENT NO	PROJECT NO.	TASK NO	WORK UNIT NO.												
63756E	N/A	N/A	N/A												
<b>11. TITLE (Include Security Classification)</b> A Practical Guide to the Technology and Adoption of Software Process Automation															
<b>12. PERSONAL AUTHOR(S)</b> Alan M. Christie															
<b>13a. TYPE OF REPORT</b> Final	<b>13b. TIME COVERED</b> FROM                      TO	<b>14. DATE OF REPORT (year, month, day)</b> March 1994	<b>15. PAGE COUNT</b> 128												
<b>16. SUPPLEMENTARY NOTATION</b>  															
<b>17. COSATI CODES</b> <table border="1" style="width: 100%; border-collapse: collapse; margin-top: 5px;"> <thead> <tr> <th style="width: 33%;">FIELD</th> <th style="width: 33%;">GROUP</th> <th style="width: 33%;">SUB. GR.</th> </tr> </thead> <tbody> <tr><td> </td><td> </td><td> </td></tr> <tr><td> </td><td> </td><td> </td></tr> <tr><td> </td><td> </td><td> </td></tr> </tbody> </table>		FIELD	GROUP	SUB. GR.										<b>18. SUBJECT TERMS (continue on reverse of necessary and identify by block number)</b> software process automation, CASE tools, software process improvement	
FIELD	GROUP	SUB. GR.													
<b>19. ABSTRACT (continue on reverse if necessary and identify by block number)</b> Process automation provides a means to integrate people in a software development organization with the development process and the tools supporting that development. For many reasons, this new technology has the potential to significantly improve software quality and software development productivity. As yet, however, there is little practical experience in its day-to-day use. The main goal of this report is thus to provide information for organizations that are considering its adoption. For these reasons, the report aims to identify how process automation relates to both process improvement and CASE tools, to review in some detail two of the major commercial process automation <p style="text-align: right; margin-top: 10px;">(please turn over)</p>															
<b>20. DISTRIBUTION/AVAILABILITY OF ABSTRACT</b> UNCLASSIFIED/UNLIMITED <input checked="" type="checkbox"/> SAME AS RPT <input type="checkbox"/> DTIC USERS <input checked="" type="checkbox"/>		<b>21. ABSTRACT SECURITY CLASSIFICATION</b> Unclassified, Unlimited Distribution													
<b>22a. NAME OF RESPONSIBLE INDIVIDUAL</b> Thomas R. Miller, Lt Col, USAF		<b>22b. TELEPHONE NUMBER (include area code)</b> (412) 268-7631	<b>22c. OFFICE SYMBOL</b> ESC/ENS (SEI)												

ABSTRACT — continued from page one, block 19

products, and to address relevant organizational adoption issues. It is hoped that the report will help bridge the gap between those whose focus is software process improvement and those whose focus is software technology.