

PROCUREMENT EXECUTIVE, MINISTRY OF DEFENCE
SIGNALS RESEARCH AND DEVELOPMENT ESTABLISHMENT

REPORT NO 75007

ADA 279 119

OPERATION AND PERFORMANCE OF A SIMPLE MULTIMODE
TRACKING SYSTEM FOR SATELLITE COMMUNICATIONS

M CHIVERS

Accession For	
NTIS CRA&I	<input checked="" type="checkbox"/>
DTIC TAB	<input checked="" type="checkbox"/>
Unannounced	<input type="checkbox"/>
Justification	
By	
Distribution /	
Availability Codes	
Dist	Avail and/or Special
A-1	

SUMMARY

This report sets out the results of tests on a simple multimode microwave aerial tracking system built under contract for SRDE. A description of the equipment and suggestion for an improved model are included. The system was found to operate very satisfactorily and in accordance with the specification.

**Best
Available
Copy**

CONTENTS LIST	Page
1. INTRODUCTION	1
2. DESCRIPTION OF TRACKING SYSTEM	1
2.1 Outline of Theory of Operation	1
2.2 Details of Microwave Section	2
2.3 Details of Demodulator Section	2
3. TESTING AND PERFORMANCE OF TRACKING SYSTEM	4
4. TESTS PERFORMED BY MARCONI CO AT GREAT BADDOW	4
4.1 Description of Test Range	4
4.2 Test Results	4
4.2.1 Loss in Transmit Band	4
4.2.2 Loss in Receive Band	4
4.2.3 Alignment of Tracking Axes	5
4.2.4 Variation in Tracking Error with Change in Signal Level	5
4.2.5 Offset between True Electrical Boresight and Indicated Boresight	6
4.2.6 Tracking Error Indicator Output Signal to Noise Ratio	6
5. TESTS PERFORMED AT SRDE	
5.1 Test Apparatus	6
5.1.1 Satellite Test Apparatus	6
5.1.2 Test Antenna Pattern Measurement	7
5.2 Satellite Tests	7
5.2.1 Acquisition Margin	7
5.2.2 Tracking Error Indicator Output Signal to Noise Ratio	7
5.2.3 Linearity of Indicated Tracking Error Versus 'Off Boresight' Angle	8
5.2.4 Dynamic Range	8
5.2.5 Offset between 'True' and 'Indicated' Boresight	8
5.3 Non Satellite Tests at SRDE	9
5.3.1 Insertion Loss	9
5.3.2 Tests with High Power Transmitter	9
6. SUMMARY OF COMPLIANCE WITH TARGET SPECIFICATION	9
7. DISCUSSION	11
8. CONCLUSIONS	12
9. REFERENCES	13

DIAGRAMS

FIG

- 1 TE_{11} and TM_{01} mode radiation patterns
- 2 Waveguide system
- 3 Bi-phase modulation spectrum
- 4 Mode coupler and hybrid tee
- 5 Microwave section of tracking system
- 6 Tracking system schematic
- 7 Beacon receiver and tracking demodulator unit
- 8 Transmit band insertion loss
- 9 Corrected receive band insertion loss and noise temperature
- 10 Axis rotation with temperature
- 11 Error voltage output Vs signal input level
- 12 Percentage change in error signal for a ± 5 dB change in signal input
- 13 Test set up
- 14 TE_{11} and TM_{01} mode radiation patterns of the 2 metre Cassegrain antenna
- 15 Sample of elevation channel output recording
- 16 Elevation error channel output signal Vs variation of demodulator input level
- 17 Elevation error channel voltage Vs off boresight angle (A), TE_{11} mode antenna pattern symmetry (B)
- 18 Elevation error channel voltage Vs off boresight angle
- 19 Change in elevation channel error volts with input signal level
- 20 Ohmic losses in receive band

APPENDIX A

APPENDIX B

1. INTRODUCTION

In recent years part of the SRDE programme of research on satellite communications has been directed towards the design of SHF earth stations which will be much simpler, more reliable and cheaper than the ones now in existence. This work has included the construction of aerial tracking systems less complex than those at present in service, current systems being considered unnecessarily complex because they generally employ several feed horns and associated low noise amplifiers, or use mechanical devices for their operation.

In 1970 intra-mural work commenced on a simple microwave tracking system. The basis of the system was the derivation of information for tracking purpose by sensing the presence of a particular waveguide mode which is normally generated by an aerial when the angle of arrival of an incoming circularly polarised signal is slightly off the axis of the aerial. The system was partly based on that used at the Andover, Maine earth station¹, but it differed in that microwave and base-band systems were much less complex², in particular only one feed-horn, one parametric amplifier and one receiver system had to be used.³ The SRDE system was sufficiently developed for it to be successfully demonstrated in conjunction with a 3.9 m diameter spherical aerial system on the SRDE Open Days in 1971. Subsequently it was thought that the system should be developed further and in preparation to placing a contract an SRDE Technical Specification was written in 1971.⁴ Following this, a contract was placed with the GEC - Marconi Electronics Ltd Research Laboratories, Great Baddow, in 1973.

The contract objectives were:-

- i to study the design of simple multimode tracking systems
- ii to determine the most favourable configuration(s) in the context of small and medium sized earth stations
- iii to provide detailed design information
- iv to produce one or more systems for evaluation by SRDE

Work on the contract started early in 1973 and the Marconi Design Study Report⁵ was produced in June 1973. This described several possible configurations and summarised their respective merits and drawbacks. Using this report, a choice of system was made and in February 1974 a completed system was delivered to SRDE and installed by Marconi engineers.

The main body of this report consists of a description of the operation of the tracking system, an account of the tests performed on it and the results obtained.

2. DESCRIPTION OF TRACKING SYSTEM

2.1 Outline of Theory of Operation

The system is based on the phase and amplitude variations of the TE_{11} and TM_{01} modes that are excited in the circular wave guide of an antenna by an off-axis signal source.

The TE_{11} mode signal (which is used for communications) is maximum when the distant source is on the axis (on boresight) of the circular guide. At the same time the TM_{01} mode signal is minimum. Departure from boresight results in a reduction of the TE_{11} signal and an initial rapid rise in the TM_{01} mode signal. See Fig 1.

The phase of the TE_{11} mode is virtually independent of angle of arrival of the signal, whereas the phase of the TM_{01} mode depends strongly on the direction of the off axis source. The TM_{01} mode signal will in fact change in phase by up to 360° as the pointing of the antenna describes a circle around the distant source. Thus by examining the relative amplitudes and phases of the TE_{11} and TM_{01} mode signals it is possible to determine the angle of arrival relative to boresight. Antenna tracking is performed on a low power beacon signal radiated by the satellite.

The TM_{01} mode signal is extracted by a mode coupler situated between the antenna feed horn and diplexer, and bi-phase modulated at 1 kHz. (See Fig 2 which is a block diagram of the waveguide system). This modulation generates a series of sidebands at 1, 3, 5 kHz etc: with respect to the carrier. (See Fig 3). The sidebands are re-injected into the main waveguide run via the mode coupler as TE_{11} mode signals and are amplified together with the normal TE_{11} mode signals (communications channel and beacon) by a single parametric amplifier. The signals are then down converted to IF (93.1 MHz) and fed to the tracking demodulator where the tracking information contained in the 1 kHz side bands is extracted and presented as elevation and azimuth antenna pointing errors.

2.2 Details of Microwave Section

Considering Fig 2, the TE_{11} and TM_{01} mode signals from the antenna enter the polarizer where the circularly polarised TE_{11} is transformed to a plane polarised signal, in the normal way. Any TM_{01} mode signal energy generated by an off axis signal passes through the polariser and is extracted by the mode coupler and fed into the hybrid T. Some TE_{11} mode signal energy is also coupled out. Due to the configuration of the TE_{11} and TM_{01} mode fields the phase of the signals in the hybrid T arms is such that it splits up the signals and directs the TM_{01} and TE_{11} mode energies to different ports. The TM_{01} mode energy is modulated by a phase modulator consisting of a 3 dB side wall coupled hybrid terminated by PIN diodes a quarter of a wave in front of short circuits. Switching the diodes results in bi-phase modulation of the TM_{01} mode energy signal. The phase modulated signal after passing through an isolator and a beacon band pass filter is fed into the TE_{11} port of the hybrid T. It is then re-injected into the main circular waveguide. The TE_{11} mode energy at the beacon frequency which has been coupled out passes through the beacon filter and is absorbed in the isolator. This prevents such energy being phase modulated and re-injected in the main waveguide as TM_{01} mode energy. The beacon filter is placed so that it presents a short circuit at the coupler ports to signals in the communications band, thus preventing these signals being coupled out and lost. A matching section (not shown) is placed between the mode coupler and the diplexer.

Figure 4 is a cutaway section of the mode coupler, Fig 5 is a sketch of the mechanical layout of the complete microwave section of the tracking system.

The communications channel signals, the beacon signal and sidebands of the beacon signal arising from bi-phase modulation of the TM_{01} mode signal are all amplified in one parametric amplifier. (The diplexer and receive band pass filter prevent transmitter power reaching the parametric amplifier). The beacon signal is then converted to IF (93.1 MHz) by the down converter and applied to the demodulator.

2.3 Details of Demodulator Section

From the description of the microwave section it is apparent that the signal at the beacon frequency will consist of two superimposed components; an

unmodulated signal corresponding to the normal TE_{11} mode, and a signal of arbitrary phase derived from the TM_{01} mode which is 'labelled' by being square wave phase modulated at 1 KHz. The purpose of the tracking demodulator is to provide tracking information by examining the amplitude and phase of the TM_{01} mode relative to the TE_{11} mode signal.

A simplified block diagram of the tracking receiver is shown in Fig 6. For convenience of explanation this diagram is further sub divided into five sections A, B, C, D, and E. The purpose of section A is simply to down convert the microwave signal to 93.1 MHz. The overall function of sections B and C is to derive two 1 KHz square waves, the amplitudes of which are proportional to the Azimuth and Elevation tracking errors. In section D the square waves are coherently detected with respect to the square wave used to modulate the microwave phase shifter, this is done to improve sensitivity and to determine the 'sense' of the error.

Considering the sections in more detail, section B contains a down converter and phase locked loop. This enables the signal to be further down converted and locked in phase to the 2.8 MHz crystal controlled source. The outputs of this section are therefore the modulated signal converted to 2.8 MHz plus a 'clean' unmodulated signal from the local oscillator phase locked to the centre frequency of the incoming signal.

At the input to section C the modulated signal is connected to the 'Azimuth' and 'Elevation' branches. The section contains identical coherent detectors in each branch. Both are connected to the 2.8 MHz signal. The 'reference' to each of the coherent detectors is derived from the 2.8 MHz source (which was locked to the signal in section B). A 90° phase shift is applied to the reference of one detector. The output of each detector is a 1 KHz square wave. Since the references applied to the detectors are in quadrature the relative amplitudes of the square wave outputs will be proportional to the RF phase of the modulated TM_{01} signal as resolved into 'in-phase' and quadrature components respectively. By suitable adjustment of the pre-set phase shifter the square wave output of each of the detectors can be made to correspond to elevation and azimuth error signals. The coherent detectors are also responsive to amplitude, hence the absolute magnitude of the output of each detector is a measure of the magnitude of the elevation or azimuth tracking error.

In section D the 'sense' of the tracking error is determined and the signal-to-noise of the two 1 KHz channels further improved by coherent detection with respect to the 1 KHz (which also drives the microwave phase shifter) source and filtering. The resultant DC constitutes the required outputs.

Section E consists only of an electronic phase shifter. Its purpose is merely to compensate for phase shifts generated in the microwave filter due to changes of ambient temperature. This compensation is required because any changes in the phase shift due to temperature would result in an apparent rotation of the pointing axes, eg the 'azimuth' channel would contain some 'elevation' information and vice versa.

The tracking demodulator also incorporates AGC circuitry (not shown in Fig 6). Further circuit details are given in Ref 6.

The prototype equipment (not designed for minimum size, weight etc) is housed in a 21.5 cm high, 48.26 cm rack mounted unit. See Fig 7. Power supplies are separate. The front panel carries four meters to show the departure from nominal frequency of the search oscillator, the beacon signal level, and the

elevation and azimuth error outputs. Signal acquisition is indicated by the lighting of a lamp.

3. TESTING AND PERFORMANCE OF TRACKING SYSTEM

The tracking system was designed to be tested in conjunction with a 7/8 GHz 2 metre diameter antenna, as this was thought to be about the smallest size antenna that such a tracking system was likely to be used with in service. The use of such a small antenna provides a stringent test of the system as the available signal was small. The antenna was built at SRDE and to avoid its transportation to the contractor's plant, a simple horn was used as an aerial during the contractor's tests.

The description of the testing of the system is therefore split into two sections. The first deals with the tests performed by Marconi staff at Great Baddow and the second deals with the tests performed at Steamer Point SRDE using the 2 metre antenna and satellites.

4. TESTS PERFORMED BY MARCONI CO AT GREAT BADDOW

NOTE: Only those tests directly related to the Technical Specification⁶ are described. A more detailed account of all tests performed by the Marconi Company is given in Ref 7.

4.1 Description of Test Range

The microwave section of the tracking system and the feed horn were mounted on a remotely controlled turntable placed on the roof of a trailer. The feed horn was approximately 5 m above ground level. The output of the tracking system was connected to down-conversion and base-band equipment inside the trailer.

To simulate a satellite beacon signal for test purposes, a crystal controlled high stability CW source was constructed. Its output was coupled to a circularly polarised horn mounted on top of a 6.7 m high tower 13 m away from the system under test.

To check the thermal stability of the system a temperature controlled enclosure was built to house the microwave section of the tracking system. The feed horn was not enclosed so that the system could still receive signals whilst undergoing thermal tests. The temperature range of the enclosure was that required by the specification.

4.2 Test Results

4.2.1 Loss in Transmit Band

The target specification required the insertion loss of the microwave section of the system to be less than 0.2 dB over the transmit band 7975 to 8025 MHz. Figure 8 shows the measured loss and this meets the specification over the whole band.

4.2.2 Loss in Receive Band

The target specification required the degradation of the receiving noise temperature due to the insertion of the tracking system to be less than 15^o K over the band 7250 to 7300 MHz.

Assuming an antenna temperature of 47°K and an ambient of 283°K (10°C) the above implies that the ohmic loss of the tracking system should not exceed 0.29 dB. Fig 9 shows the measured insertion loss over the band. The reflection coefficients over the band were converted to VSWR loss (also plotted) and this was subtracted from the measured insertion loss to obtain the ohmic loss. It can be seen from the figure that the target specification was met over most of the band.

As explained in paragraph 2.2 a beacon band pass filter is used to prevent loss of communications band signals. The inevitable finite skirt response of this filter is responsible for the small but increasing loss at the top end of the communications band.

4.2.3 Alignment of Tracking Axes

Changes in temperature of the microwave section of the tracking system cause variations in the path lengths which would, if not compensated for in the demodulator section, cause the tracking axes to rotate ie, the 'elevation' channel would also be sensitive to azimuth and vice versa. To test the effectiveness of the compensation system the tracking axes were aligned and the temperature of the microwave section varied over the specified temperature range (-7°C to $+27^{\circ}\text{C}$). The deviation of the axes from their nominal position was measured every few degrees Centigrade. The observed deviations are shown in Fig 10. It will be seen that at certain temperatures the angle between the axes differs by up to 5° from the nominal 90° . The reason for this is not known.

The target specification required the ratio between the true error signal and an orthogonal false error signal to be a maximum of 10:1. This implies that the axes must be within 5.7° of their nominal position. These limits are drawn on Fig 10 which shows that this requirement is met over the majority of the temperature range. The small amount by which the specification was not met will not be serious in practice.

4.2.4 Variation in Tracking Error with Change in Signal Level

The target specification required that the variation in indicated tracking error caused by a + 10 dB change in signal strength should not be greater than 10%. The change was subsequently amended to ± 5 dB. See Appendix B.

To test the performance of the system the feed was offset by half a beam width and the output of the elevation and azimuth channels recorded as the level of the signal into the demodulator was varied. The results are shown in Fig 11.

Derived from this result Fig 12 shows the percentage change in error signal of both channels when the input to the demodulator was stepped + 5 dB for a number of nominal mean input levels. It will be seen that the azimuth channel performance met the specification, but that the elevation channel change exceeded the specified limit at some input levels. No reason for the different behaviour of the two channels has been given. The shortfall from the specified accuracy is not serious. However, later tests on satellite signals (See para 5.2.4) indicated a greater shortfall.

4.2.5 Offset between True Electrical Boresight and Indicated Boresight

This was initially specified as 3% FSD maximum, but was later amended, at the request of Marconi Ltd, to be "the error which would result in not more than 0.1 dB loss in communications signal" (roughly one fifth of the 3 dB beam width). See Appendix B.

The angular displacement between the true electrical boresight and the boresight as measured by the tracking system was measured and found to represent a radial error of .05 beamwidth. The angle at which the gain of the feed horn used in conjunction with the tracking system had dropped by 0.1 dB was calculated to be 0.2 beamwidths off axis. The error in indicated boresight is therefore well inside the specification limit.

4.2.6 Tracking Error Indicator Output Signal-to-Noise Ratio

The target specification required the tracking error output signal to noise ratio to be 20 dB minimum in 1/10 Hz bandwidth when certain input signal level conditions applied; namely the TM_{01} signal-to-noise to be 30 dB Hz and the signal to be off boresight by such an angle as to make the TM_{01} signal level 10 dB below the TE_{11} maximum (roughly 1/6 of a beamwidth). Under these conditions the measured value of tracking error output signal-to-noise was found to be 26 dB in a 2 Hz bandwidth, this would have given about 39 dB in a 1/10 Hz bandwidth, thereby easily satisfying the specification.

5. TEST PERFORMED AT SRDE

After completion of the tests at Baddow the tracking system was brought to SRDE and fitted to a 2 metre antenna with the object of testing the system on a typical small aerial when receiving actual satellite signals. The gain of the antenna used was measured to be about 37 dB, which is about 2 dB less than might be expected of a modern high efficiency antenna. This, together with the losses due to a long waveguide run between the antenna and the receiver, reduced the effective antenna diameter to about 0.8 to 1.2 m; the consequent reduction in signal to noise ratio placed a stringent requirement on tracking system performance. In addition to the satellite tests advantage was taken of other facilities (eg a 1 kW transmitter) available at SRDE to carry out further non satellite tests to supplement those made at Baddow.

All the satellite tests described in this section were carried out on the beacon of a defence communications satellite. The C/K_T when receiving this signal on the 2 metre antenna was measured as 41.5 dB Hz. Provision was made for reducing this further by placing a calibrated attenuator in the waveguide connecting the antenna to the parametric amplifier. See Fig 13.

5.1 Test Apparatus

5.1.1 Satellite Test Apparatus

For field tests the equipment was set up as shown in Fig 13. A 1 kW transmitter operating in the 20 MHz wide transmit band (7985 to 8005 MHz) was connected to the transmit port of the system diplexer by 21 m of waveguide 15. The loss of this wave guide run was estimated to be 1.7 dB.

The receive port of the diplexer was connected to an adjustable rotary vane attenuator (to further reduce the signal to noise ratio as required) and parametric amplifier in the laboratory via approximately

18 m of waveguide 14. The loss of this run was measured as 1.6 dB. The gain of the parametric amplifier was 25 dB. Its noise temperature was 128°K. The parametric amplifier was connected to a down converter and IF amplifier. The output of the amplifier was connected either to a spectrum analyser for signal strength measurements or to the tracking demodulator. The output of the elevation error channel of the tracking demodulator was connected to a pen recorder to obtain error signal recordings. This channel was chosen because a clinometer capable of measuring changes in the antenna elevation to 1 minute of arc was available.

5.1.2 Test Antenna Pattern Measurement

In addition, to enable antenna pattern measurements of both the TE₁₁ and the TM₀₁ modes of the 2 metre antenna used in the tests to be made by the Marconi engineers, the previously mentioned beacon signal source was coupled to a circularly polarised horn mounted on top of a 21 m high tower approximately 300 m away from the antenna.

The output of the parametric amplifier was connected to a microwave receiver. The output of the receiver was connected to the Y axis input of a pattern recorder. A synchro transmitter driven from the azimuth axis of the antenna mount was used to provide the X axis to the pattern recorder.

Fig 1- shows both the TE₁₁ and TM₀₁ mode antenna patterns. The TE₁₁ mode was measured at the Rx port of the diplexer. The TM₀₁ mode was measured at the TM₀₁ port of the mode coupler.

The lack of symmetry in the patterns is thought to be due to multipath arising from the poor quality of the test range.

Elevation plane antenna patterns were not recorded.

5.2 Satellite Tests

5.2.1 Acquisition Margin

During the first attempt at receiving signals from the satellite it was found that the available signal to noise was only just sufficient for the tracking demodulator to lock on to the signal. In order to improve this situation a number of modifications were made to the equipment. These are described in appendix A.

The specification required the system to work down to a C/KT of 30 dB Hz (TM₀₁ mode signal) which corresponded to a C/KT of 40 dB Hz for the total beacon signal. After the modifications described in appendix A had been carried out it was possible to acquire and lock on to the satellite signal with the waveguide attenuator set to 9 dB, thus giving a C/KT of about 30.5 dB Hz for the total beacon signal. The specification requirement was therefore exceeded by 9.5 dB.

5.2.2 Tracking Error Indicator Output Signal to Noise Ratio

The specification required this to be 20 dB minimum as measured in 1/10 Hz bandwidth subject to certain input signal conditions. These were that the TM₀₁ mode signal/noise was 30 dB Hz and that the TM₀₁ signal level was 10 dB below peak TE₁₁ mode signal level.

The 10 dB difference in level occurred when the antenna was 22 minutes off boresight. From a series of recordings of the elevation channel output signal the error voltage and noise was determined at this angle. With a time constant of 10 seconds in the output circuit the resulting signal to noise was 20 dB and was therefore within specification.

Fig 15 is a sample of an elevation channel output recording at plus 10, plus 20 and plus 30 minutes from boresight.

Fig 16 is a recording of the elevation channel error signal obtained when the antenna was on boresight and shows the change in noise output which occurred when the input level to the parametric amplifier was reduced.

5.2.3 Linearity of Indicated Tracking Error Versus 'Off Boresight' Angle

The elevation channel output voltage was measured at various measured off boresight angles and plotted, see Fig 17, curve A.

The system is seen to possess a linear change of output voltage with off axis angle to about + 40 minutes off boresight ie 3 dB beamwidth. The measured signal to noise level (on boresight) was 42 dB Hz.

Fig 18 shows the performance of the system when the paramp input was reduced to 34 dB Hz. It is seen that the system is linear over the same range as before but that the sensitivity (volts/minutes of arc) has decreased. This aspect is discussed below.

5.2.4 Dynamic Range

The specification required the variations in indicated tracking error to be less than 10% for a + 5 dB change in beacon signal strength. Fig 19 is a plot of the elevation channel error voltage with change in input level when the antenna was 22 minutes off boresight (approximately $\frac{1}{2}$ beamwidth). From the figure it may be seen that there is a 40% drop in error voltage for a 7 dB drop in signal level. This change in error voltage output exceeds the target specification and is greater than that which occurred during the Marconi tests. Examination of Fig 12 shows that the greatest percentage change that occurred during the Marconi tests was approximately 16%. The difference in percentage change in system performance is attributed to the presence of more noise associated with the test signal during the SRDE tests than during the Marconi tests. In a future design this aspect of performance could be improved by arranging the AGC input to operate from a part of the circuit where less noise is present.

Fig 19 also shows the associated S/N ratios at different input signal levels.

5.2.5 Offset between 'True' and 'Indicated' Boresight

The specification required that the loss in communications signal due to the offset between true boresight and that indicated by the tracking system should not exceed 0.1 dB.

Fig 17B is a plot of the antenna TE₁₁ mode pattern. From the figure there appears to be a difference of 8 minutes of arc between boresight as indicated by the tracking system and the antenna axis as determined

from the antenna pattern. The resulting pointing error results in a loss of less than 0.1 dB in received signal strength and therefore it satisfies the specification.

Fig 16 also shows that, on boresight, the system output signal is virtually unaffected by change of input signal level ie the indicated boresight position does not depend on signal strength.

5.3 Non satellite tests at SRDE

5.3.1 Insertion Loss

Following the modifications to improve the acquisition performance described in appendix A the tracking system was removed from the antenna and the loss in the receive communications band and at the beacon frequency, (previously measured at Baddow) re-measured.

The results are shown in Fig 20(a).

As the loss in the communications band exceeded the specification it was necessary to retune the 3 screw tuner to reduce the loss and simultaneously retain the previous matching conditions. After retuning, the loss was as shown in Fig 20(b).

The receive band loss of the system is seen to comply with the target specification except at the extreme top end of the band. The loss of 1.6 dB at the beacon frequency was almost exactly that calculated when the modifications to improve the acquisition performance described were first proposed.

5.3.2 Tests with High Power Transmitter

The target specification required that the indicated tracking error should not change by more than 3 per cent due to the transmission of one kilowatt of CW through the system. This test was performed at SRDE since no suitable transmitter was available on the Marconi site. The test arrangement is shown in Fig 13. Due to the length of waveguide needed to couple the transmitter to the antenna only about 700 watts was in fact available. The frequency used for the test was 7995 MHz; this is the centre of the 20 MHz transponder in the satellite. The test was carried out by switching the transmitter on and off whilst receiving the beacon signal from the satellite. No change in the output of the tracking error signal was detectable.

6. SUMMARY OF COMPLIANCE WITH TARGET SPECIFICATION

In almost all significant parameters the target specification was met or exceeded. Table 1 summarises the compliance obtained.

As the work proceeded it was found necessary to amend two items of the target specification, mainly to remove any possible ambiguity in interpretation. The amendments are set out in detail in Appendix B.

7. DISCUSSION

The tests performed on the tracking system have shown that it meets the target specification in most respects and that it is capable of tracking low power satellites.

When considering the performance of the system as tested it should be remembered that the gain of the antenna was lower and the loss of the waveguide run between

the antenna and the paramp greater than might be expected in a typical small ground station. The resulting loss of signal reduced the effective diameter of the antenna to 1 to 1.2 metres. It is anticipated that the small stations on which such a tracking system might be used will have antennas of at least 1.8 m in diameter hence a considerable increase in signal strength may be expected.

Although the present model has clearly established the feasibility of operating a multimode tracking system and the simplicity of such a system, there are several disadvantages to the present design. These are:

- a. It will work only with satellites radiating one particular beacon frequency, this being due to the use of a fixed narrow band pass filter. Satellites radiating beacon signals on different frequencies are coming into service, and hence a method must be found for the system to work over a range of frequencies. Changing the filter is one inelegant solution to the problem.
- b. The present phase modulator is rather large and its use results in the need for a bulky waveguide assembly. Two proposals for smaller modulators are given⁷. The first is a microstrip modulator and isolator with waveguide input and output ports. In the second, phase modulation is achieved by switching a PIN diode mounted in a length of waveguide on arm 2 of a circulator. Either would simplify the waveguide assembly.
- c. The beacons of certain satellites are bi-phase modulated in such a way as to completely suppress the carrier. The present equipment will not work on this type of signal.
- d. The indicated error signal is to some extent affected by variations in signal level. This is only a minor disadvantage in a practical system. The indicated 'on boresight' position is independent of signal level.
- e. The present system will work only with circularly polarised beacon signals.
- f. Variations in temperature of the waveguide system (especially the filter in the modulation loop) produce phase variations between the TE_{11} and TM_{01} modes causing an apparent rotation of the tracking axes. A compensation system is used to nullify this effect in the present prototype model, but it would be advantageous if the need for it could be eliminated.

Apart from the 'operational' limitations discussed above, there is no doubt that the technical functioning of the scheme has been very adequately demonstrated. With regard to its usefulness for practical earth stations it is apparent that the complication of the present design as it now stands makes it non-competitive for very small low-cost stations. These stations are normally fitted with small dish aerials which can be pointed adequately by simpler means, such as single-axis prediction or step track. Its use on larger high-performance stations may also be limited by the inability of the present design to tune over a wide range of beacon signals or to operate on bi-phase modulated beacons, however with large stations there is the opportunity to design for low efficiency in the beacon-signal circuits and this provides an extra degree of freedom.

There may be an application of the system for medium size land transportable stations which have to be frequently moved. The multimode system has the advantage for this class of station in that a pointing-error indication is available instantly on setting-up the station: under these circumstances step-track takes appreciable time to settle down and prediction-track systems are more difficult to set up quickly and are upset by movement of the aerial mount,

eg by settling of the vehicle on which the equipment may be mounted. For these stations the restriction as to choice of beacon may be acceptable.

Since this work was started, it has been to some extent overtaken by events, in that a number of recent developments have made the present design less competitive; these include the increased emphasis on the need to tune over a range of beacon frequencies for interoperability and satellite 'sharing', the use of bi-phase modulated beacons by the USA and the successful development of "steptrack" and simple "single axis" prediction tracking methods.

8. CONCLUSIONS

8.1 The performance of the tracking system has clearly demonstrated that it is possible to design and construct a simple multimode tracking system that will provide accurate antenna pointing information even when used with a small antenna.

8.2 There are a number of disadvantages and short comings associated with the present design. The principal one is that which limits the system to fixed frequency operation and, it is apparent that extra development work is required to produce a more flexible system for wider general application. If the use of the system is restricted to larger size aerials then important simplifications are possible.

9. REFERENCES

- 1 J S Cook and R Lovell
The Auto-Track System
The Bell System Technical Journal
P1283-1307 July 1963
- 2 T W G Dawson, P H Masterman
and M Chivers
A Simple Multimode Auto-Track System
for Steerable Aerials
SRDE Memorandum No S71/70
- 3
The following patents have been granted
in connection with this tracking system.

UK	No:	1344098
US	No:	3790941
Canada	No:	949180
- 4
Technical Specification for the Study,
Design and Manufacture of a Simple
Multimode Tracking System for Satellite
Earth Terminals
SRDE Technical Specification TS/1473
- 5 J R Brain et al
Multimode Tracking Feed Design Study
Report. Marconi Technical Report
MTR 73/63 June 1973
- 6 J R Brain et al
Multimode Tracking Feed Equipment Manual
Marconi Technical Report MTR 74/1
March 1974
- 7 J R Brain et al
Final Report on the Design and Development
of a Multimode Tracking System for SRDE
Marconi Technical Report MTR 74/9 May 1974

SUMMARY OF COMPLIANCE WITH TARGET SPECIFICATION

TABLE 1

PARAMETER	TARGET SPECIFICATION	RESULT
<u>Relating to waveguide feed</u>		
Waveguide system loss in transmit band.	0.2 dB max.	Target achieved - see Fig. 8.
Degradation of receiving noise temperature due to the insertion of the tracking system.	1 ¹ / ₂ K max: or 0.27 dB loss with feed at 240°K and 50°K antenna temperature.	Target achieved over the majority of the 20 MHz wide communications band - see Fig. 20(b).
Degradation of TE ₁₁ mode antenna gain as a result of false zero error indication.	0.1 dB.	Target achieved - see Fig. 17.
Variation in indicated tracking error caused by ± 17°C in ambient temperature. (Ambient 10°C).	± 5%.	Target achieved over 80% of the band, approx.
Increase in tracking error caused by transmitting 1 KW CW through waveguide system.	3% FSD	Target achieved.
<u>Relating to demodulator</u>		
Variation of indicated error for ± 5 dB change in input level.	< 10%	According to Marconi tests, target achieved by azimuth channel and partly by elevation channel. See Fig. 12.
Ratio between true error signal and orthogonal false error signal.	10:1 max (corresponds to 5.7° displacement of axes).	According to SRDE tests on satellite target not achieved by elevation channel. See Fig 19.
Error signal output S/N for TM ₀₁ mode 10 dB below TE ₁₁ max:	20 dB (in 1/10 Hz BW) min:	Target achieved over most of band - see Fig. 10.
		Target achieved - measured figure 21 dB in approx 1/10 Hz BW. (Only elevation channel measured).

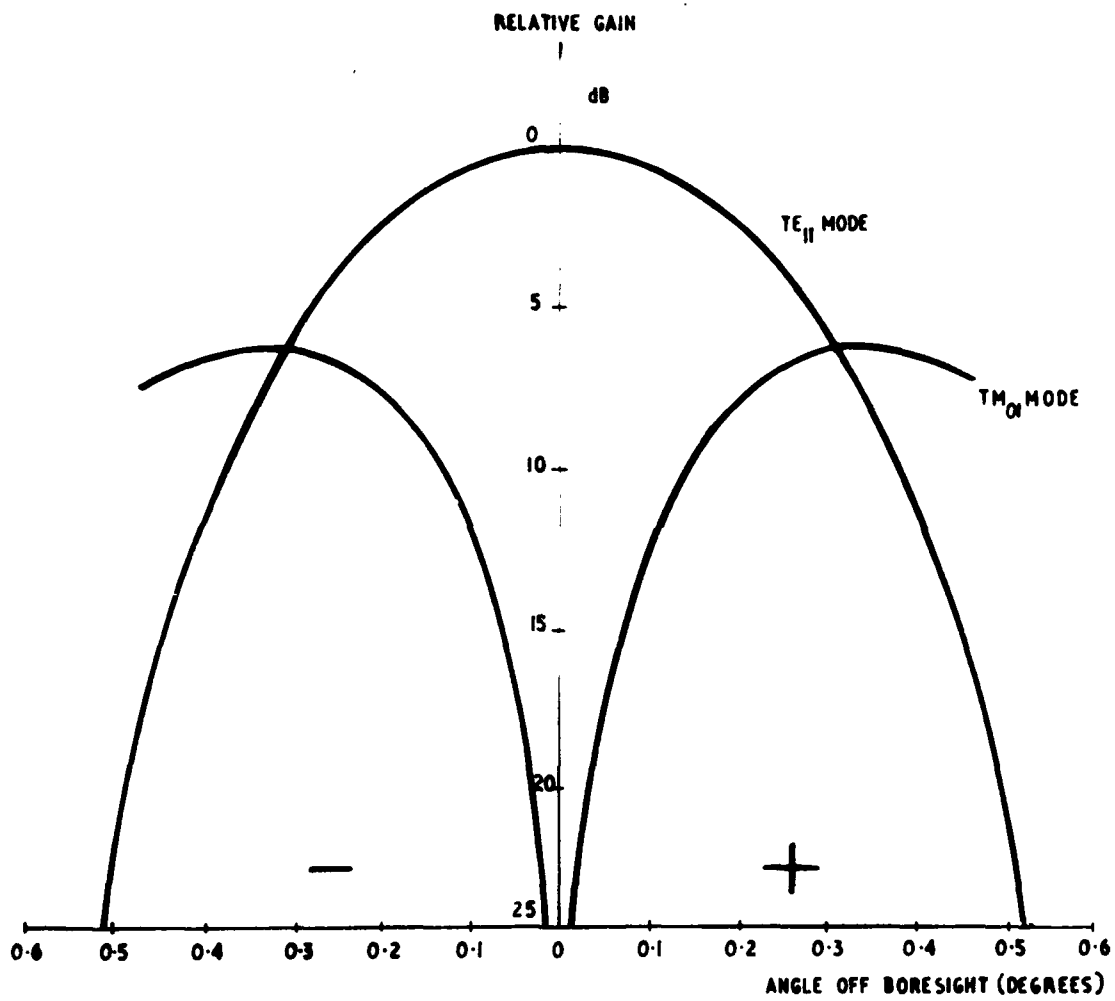

FIG 1. TE₁₁ AND TM₀₁ MODE RADIATION PATTERNS

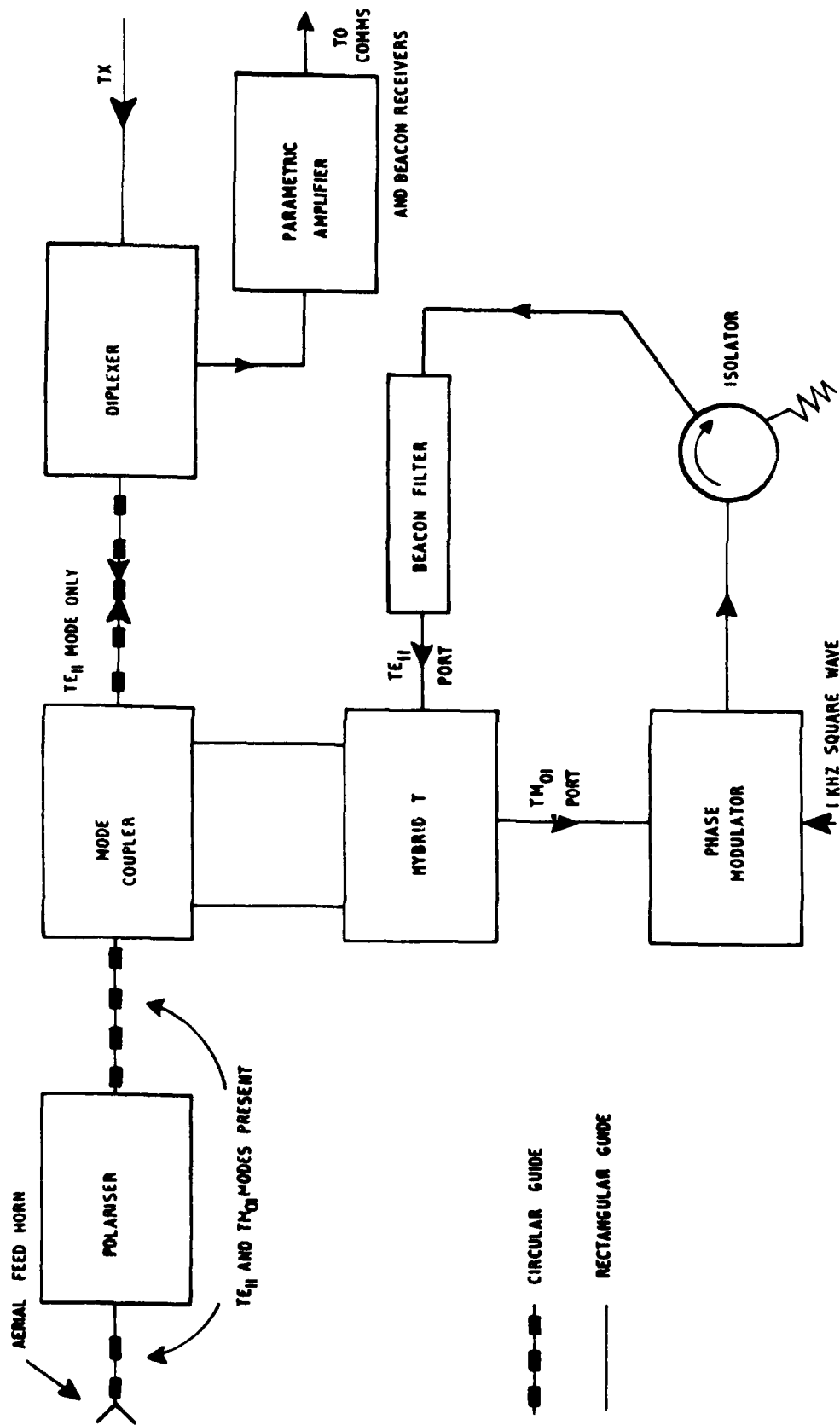

FIG. 2 WAVEGUIDE SYSTEM

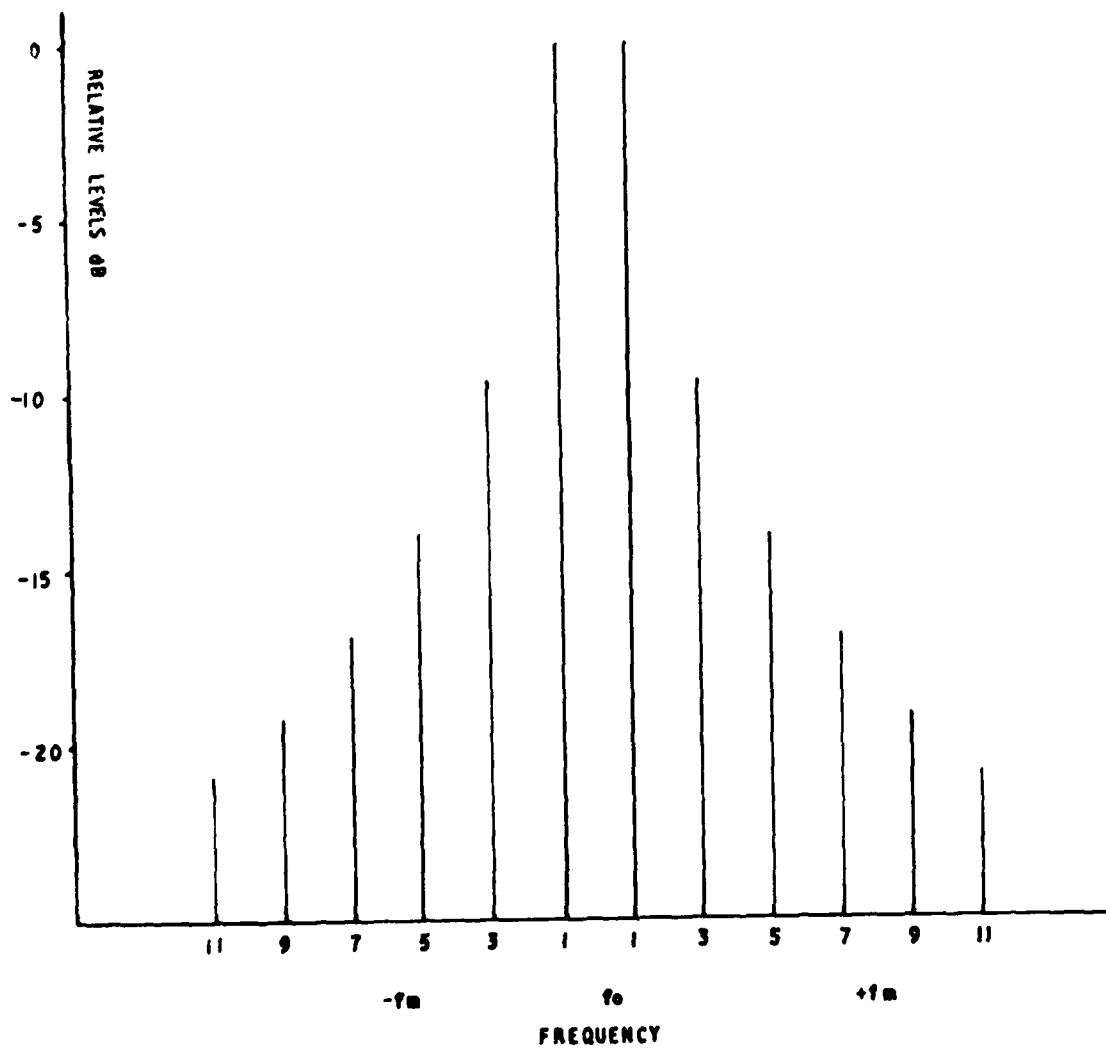

FIG. 3 BI-PHASE MODULATION SPECTRUM

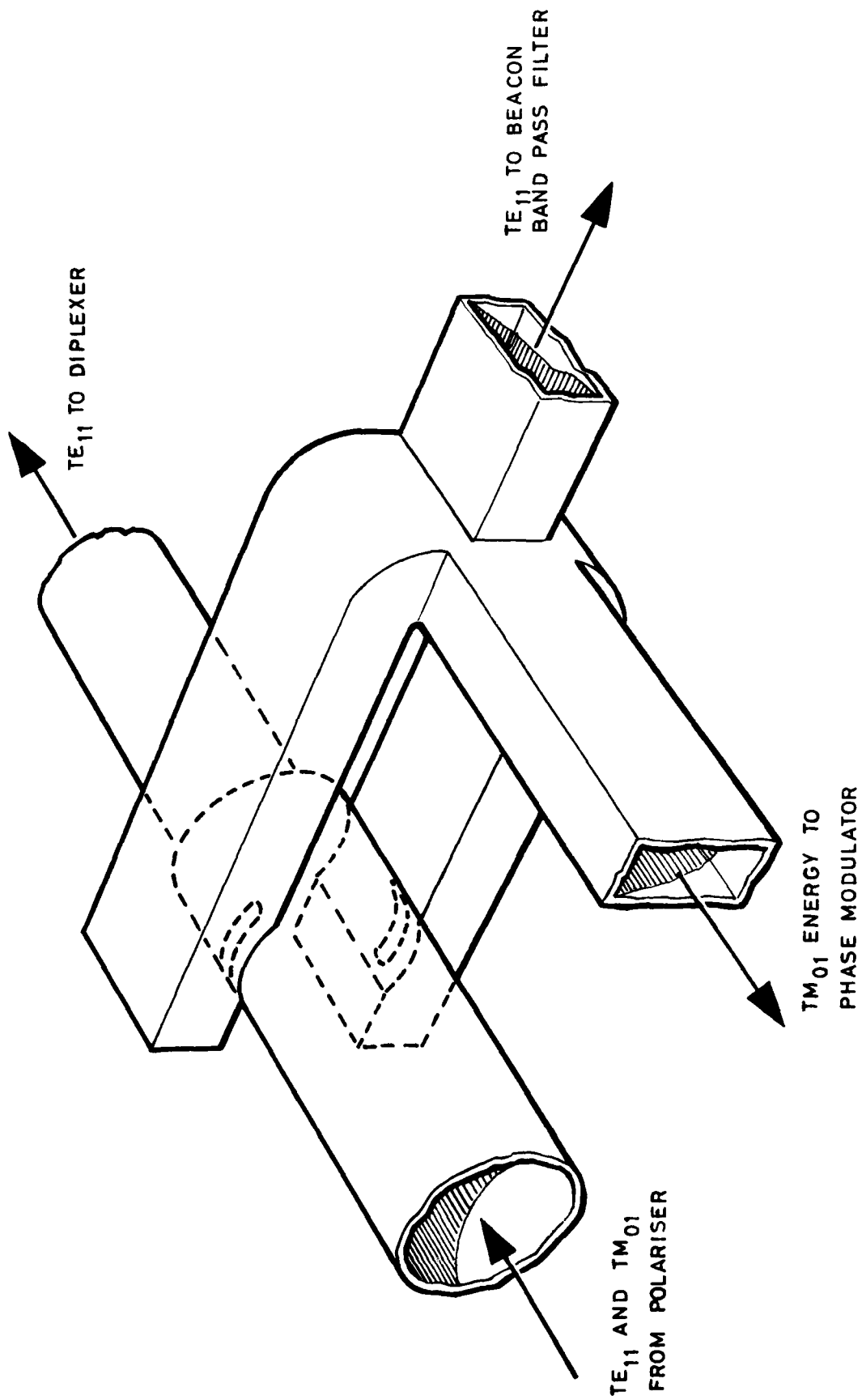

FIG.4 MODE COUPLER AND HYBRID TEE

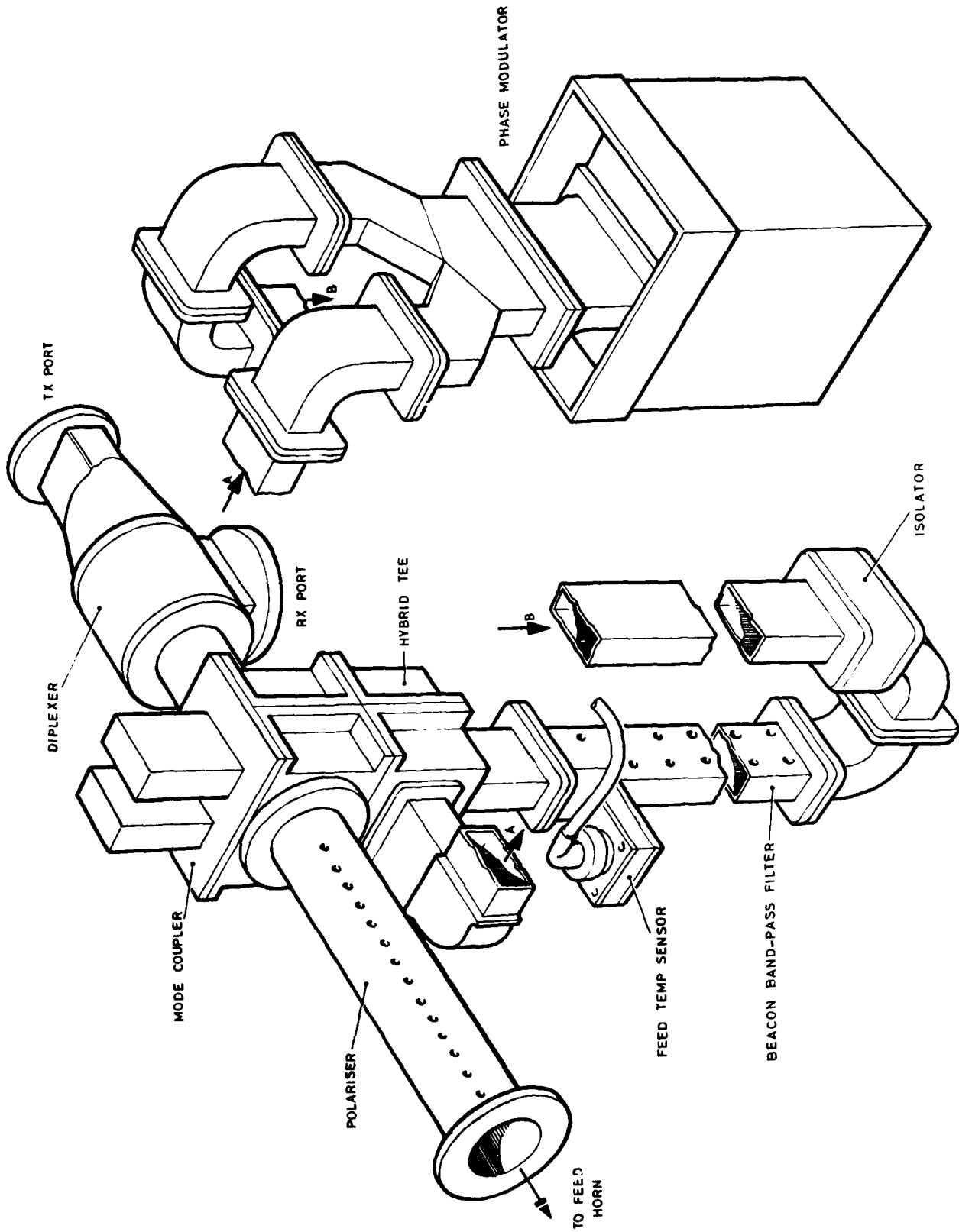

FIG.5 MICROWAVE SECTION OF TRACKING SYSTEM

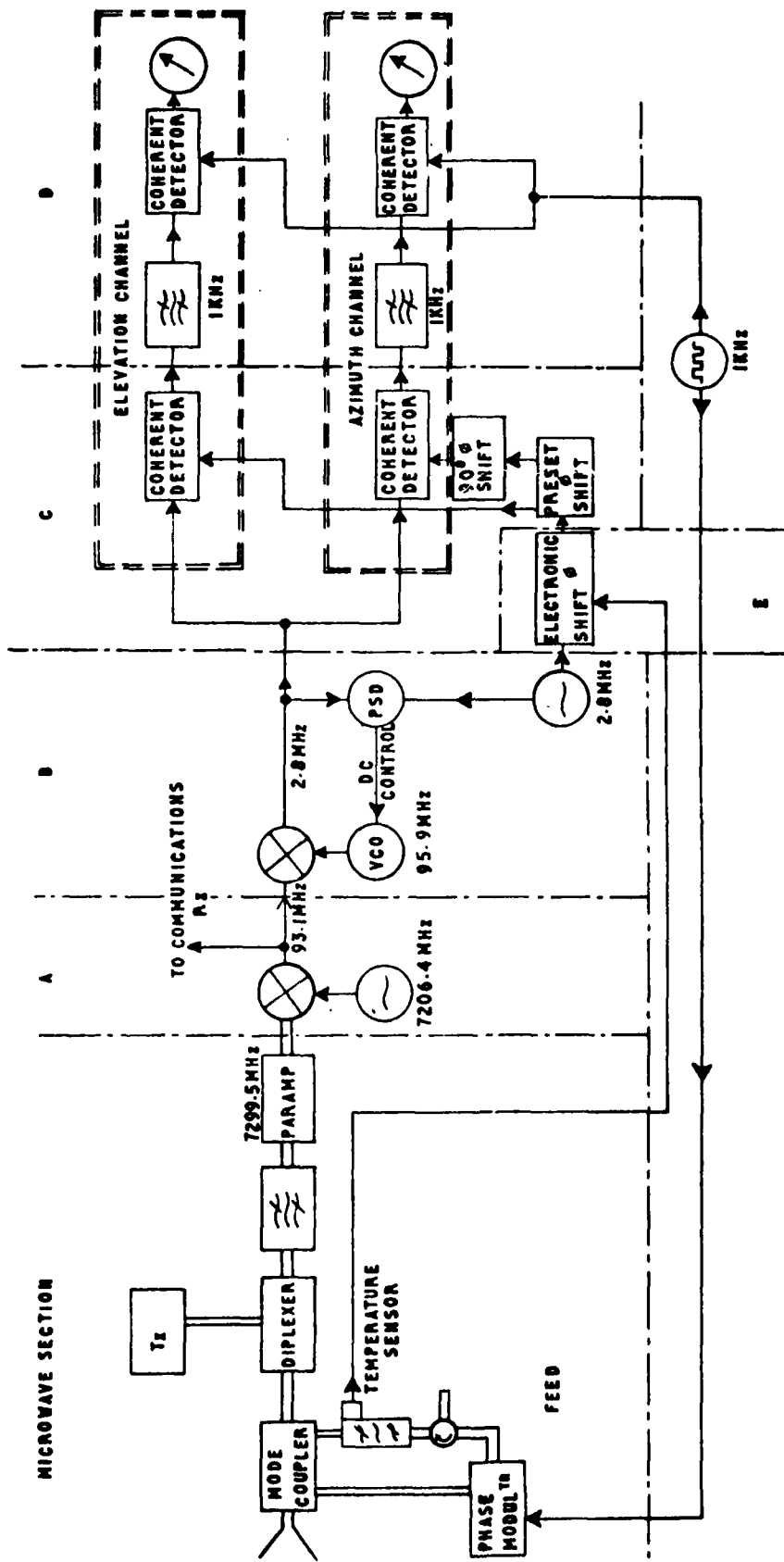

FIG. 6. TRACKING SYSTEM - SCHEMATIC

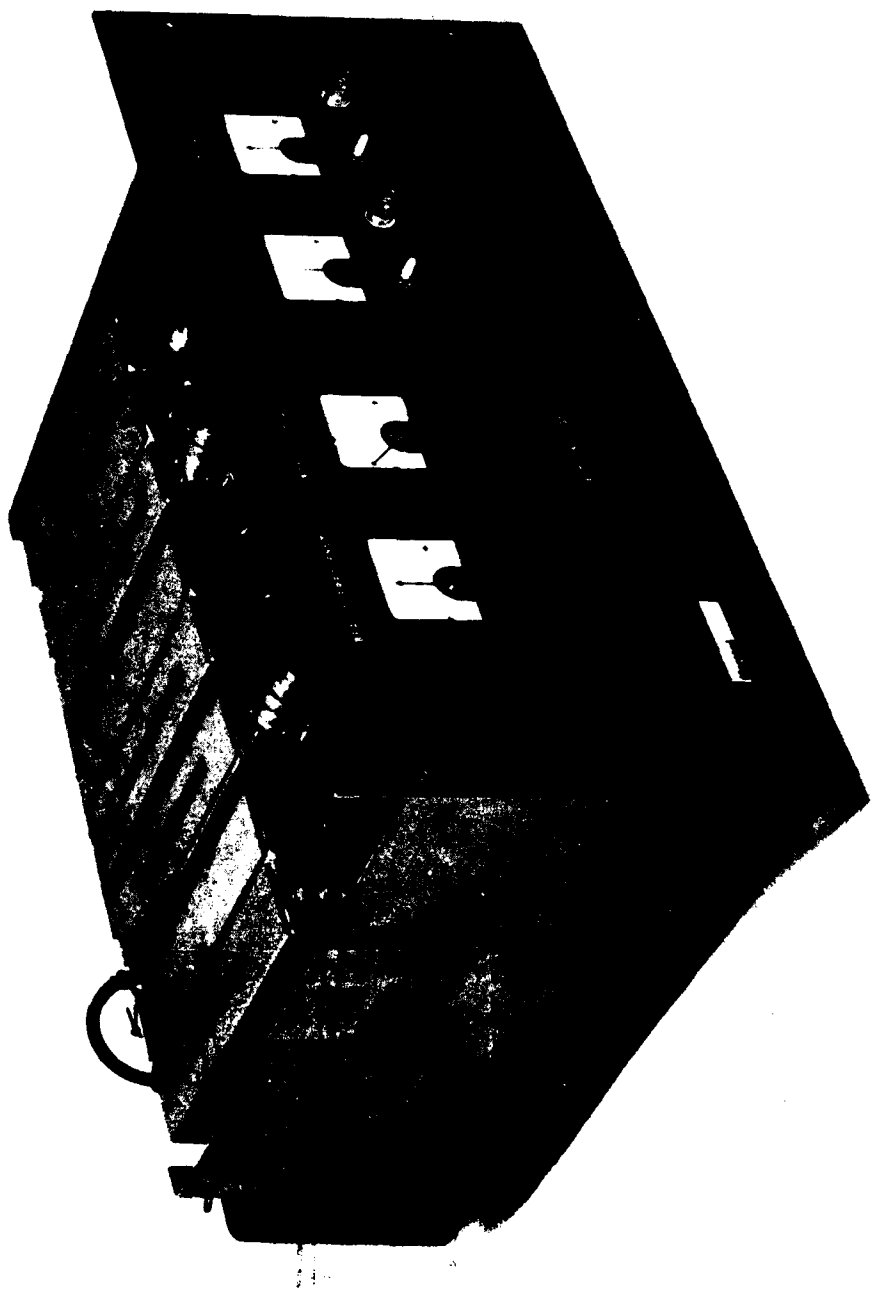

FIG.7 BEACON RECEIVER AND TRACKING DEMODULATOR UNIT

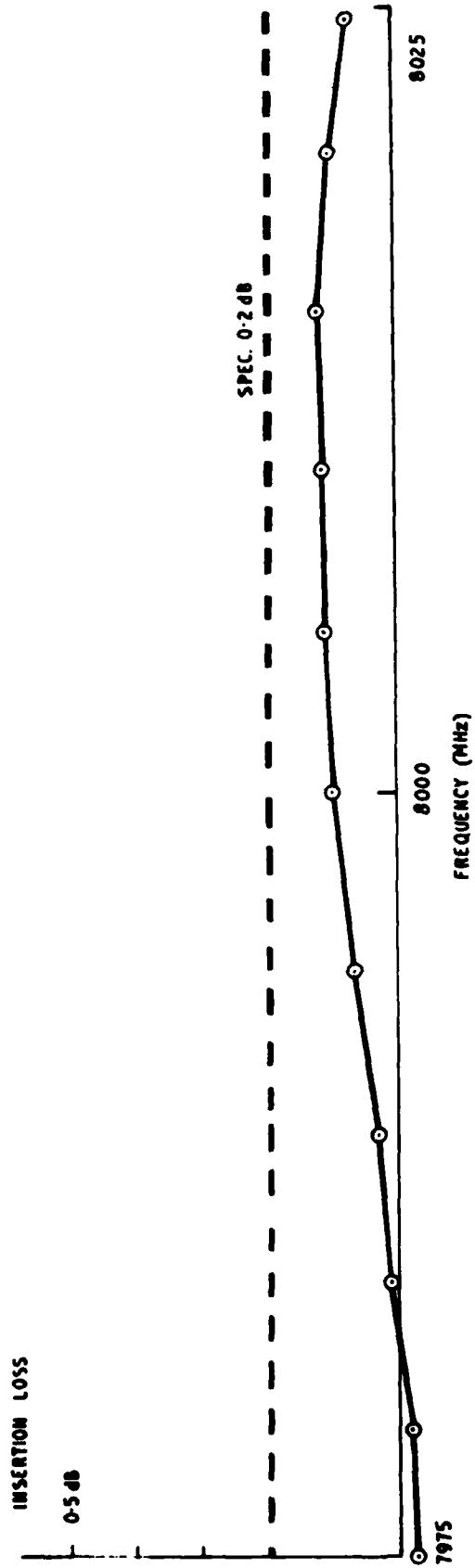

FIG 8. TRANSMIT BAND INSERTION LOSS

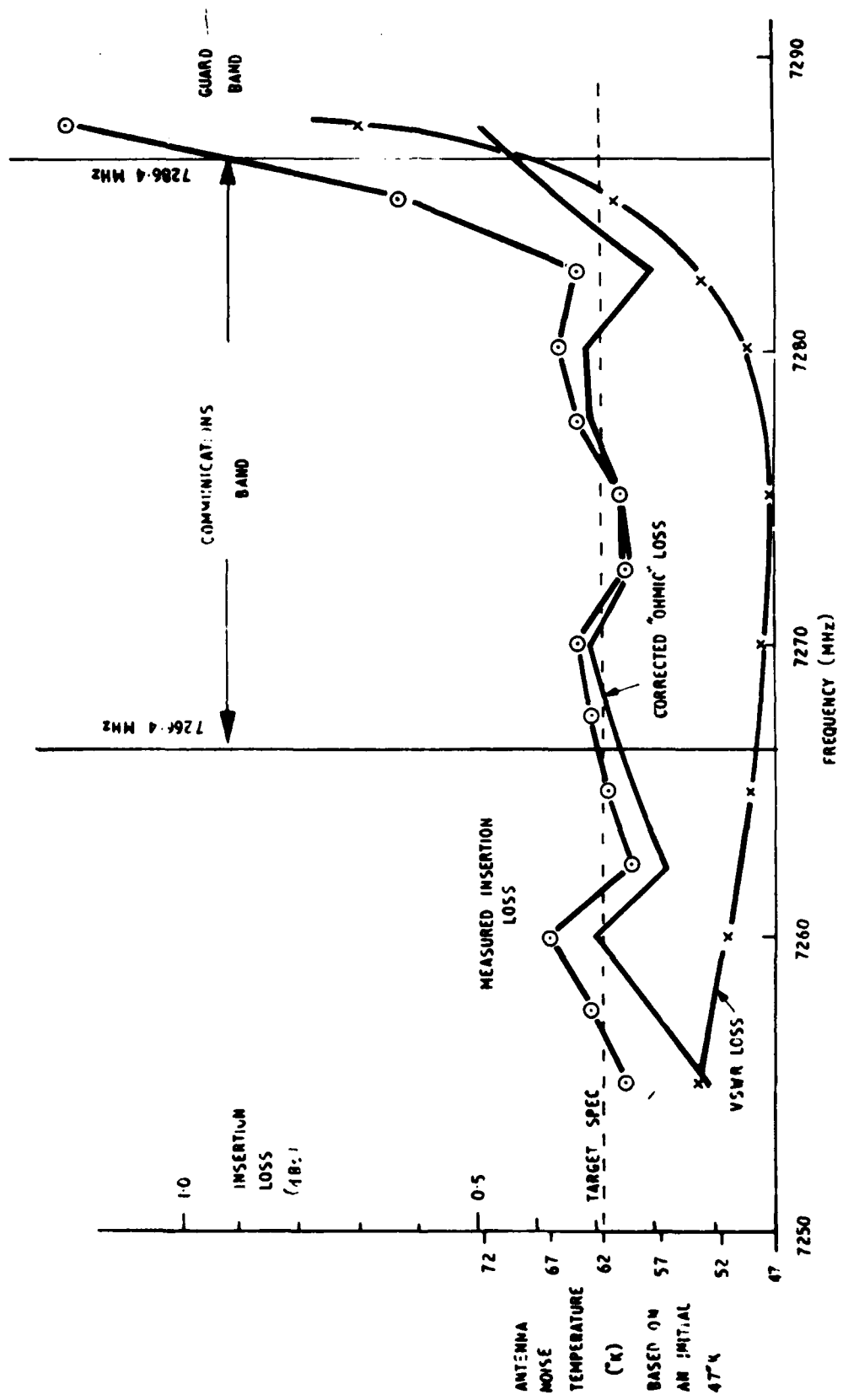

FIG 9. CORRECTED RX BAND INSERTION LOSS AND NOISE TEMPERATURE

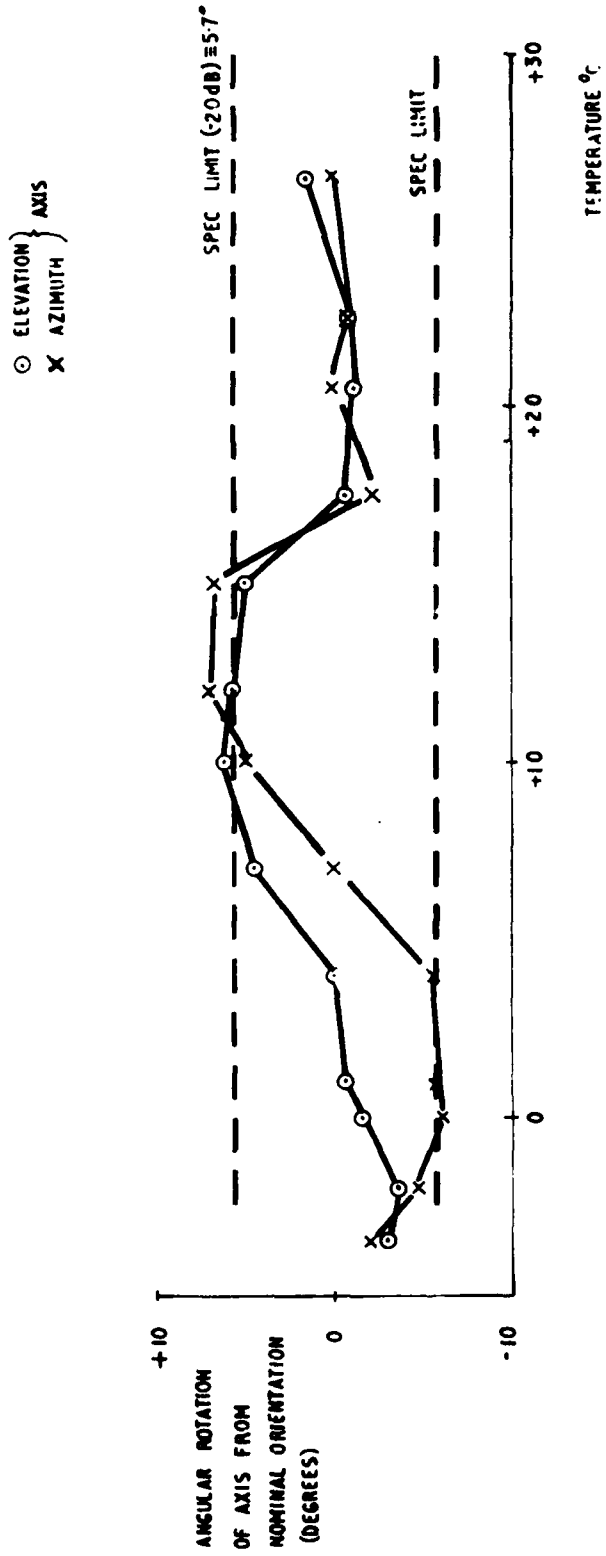

FIG 10. AXIS ROTATION WITH TEMPERATURE

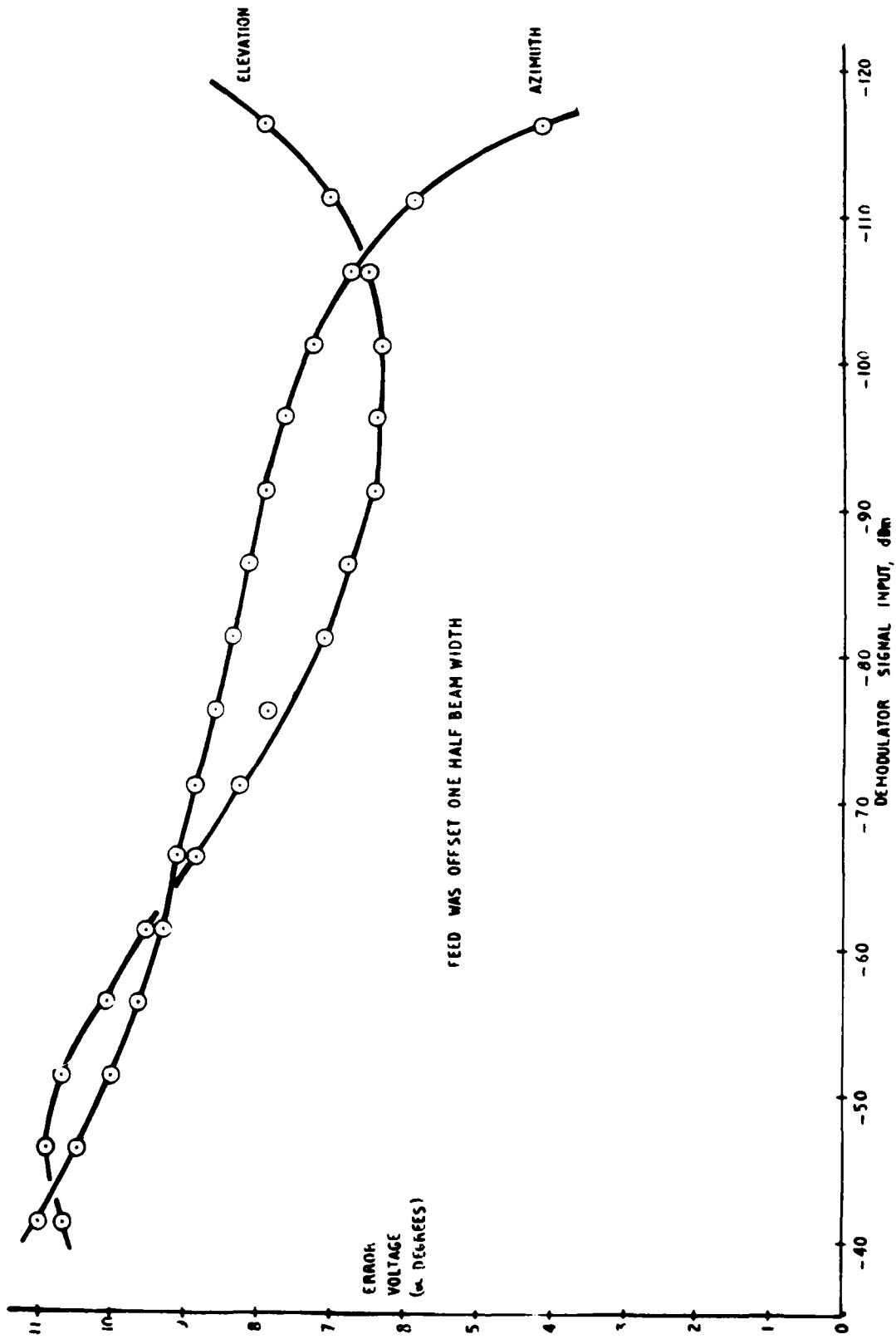

FIG II. ERROR VOLTAGE OUTPUT VS SIGNAL INPUT LEVEL

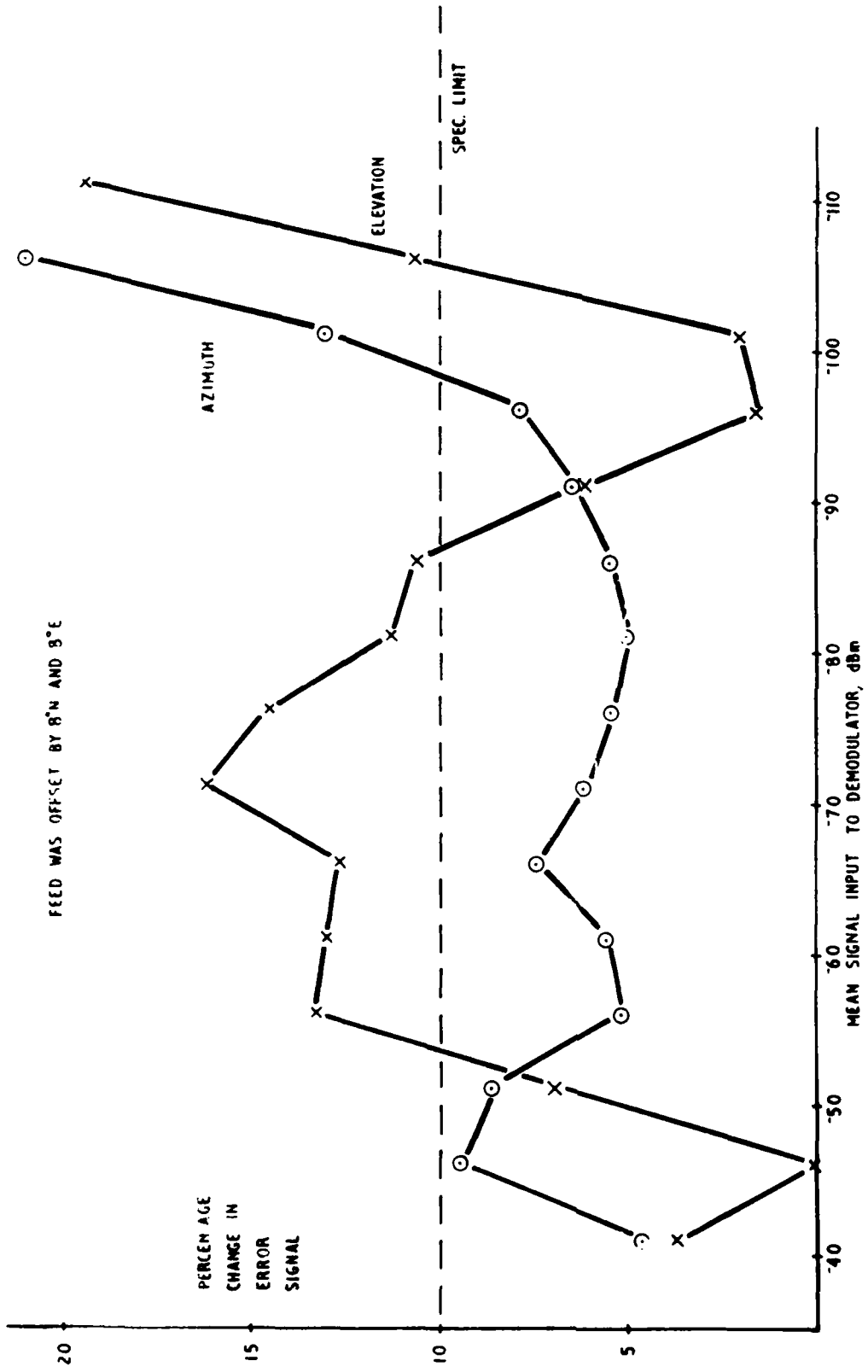

FIG 12. PERCENTAGE CHANGE IN ERROR SIGNAL FOR A ± 5 dB CHANGE IN SIGNAL INPUT

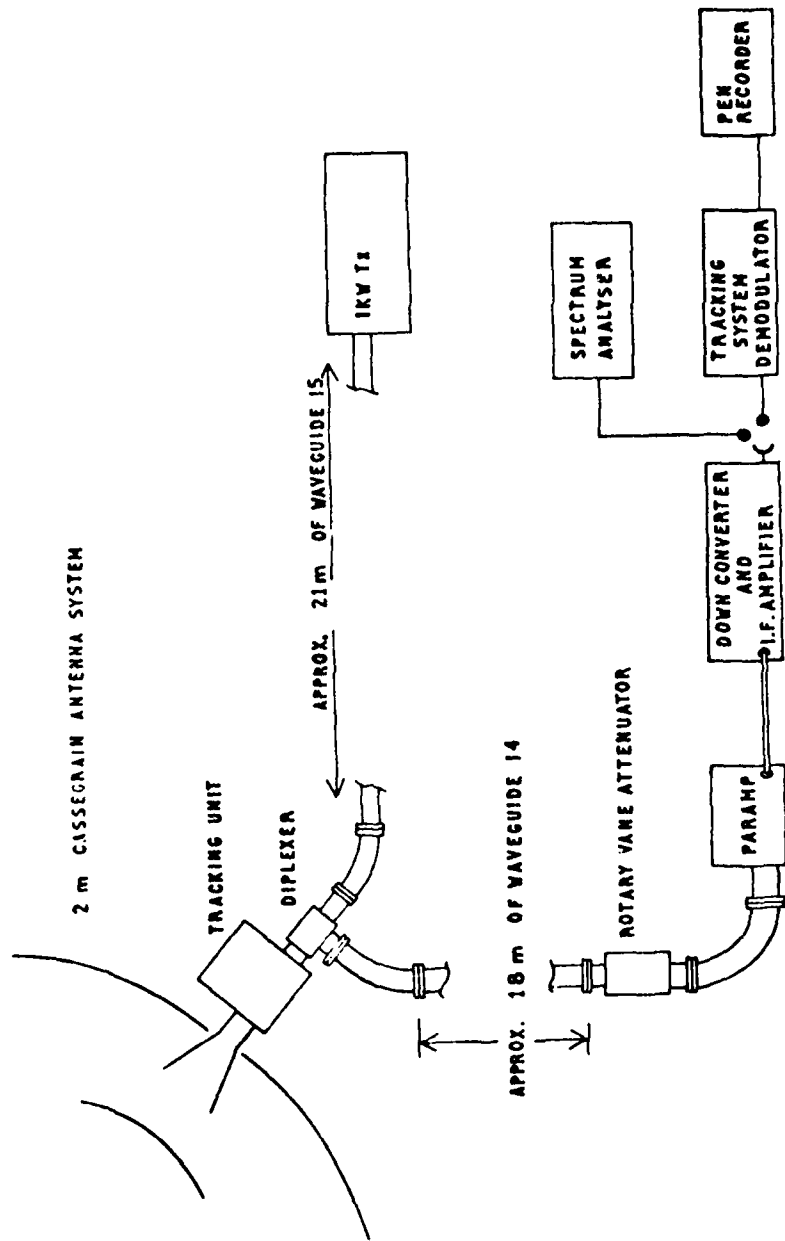

FIG. 13. TEST SET UP

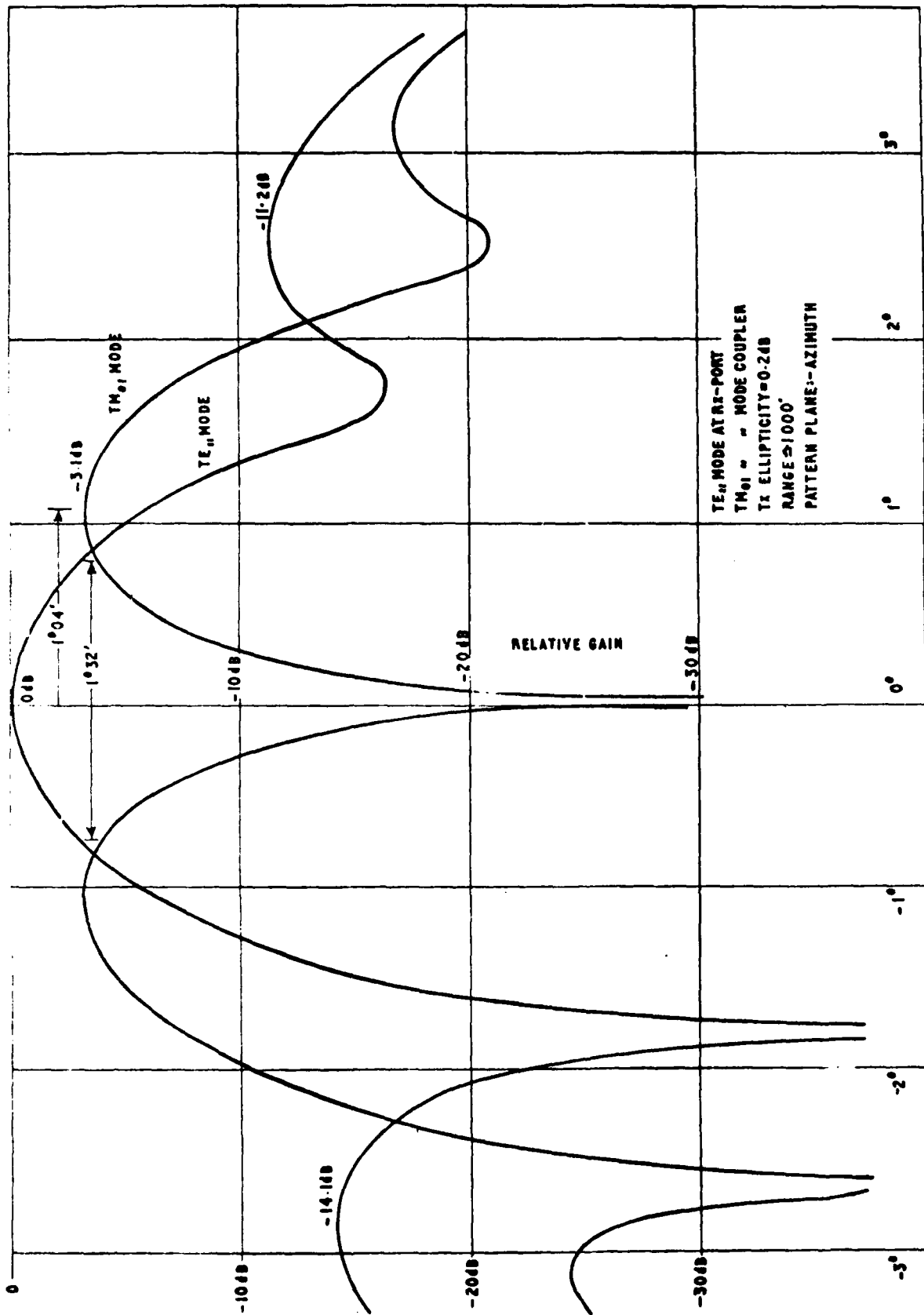

FIG. 14. TE₁₁ AND TM₀₁ MODE RADIATION PATTERNS OF 2 m CASSEGRAIN ANTENNA (7300MHZ)

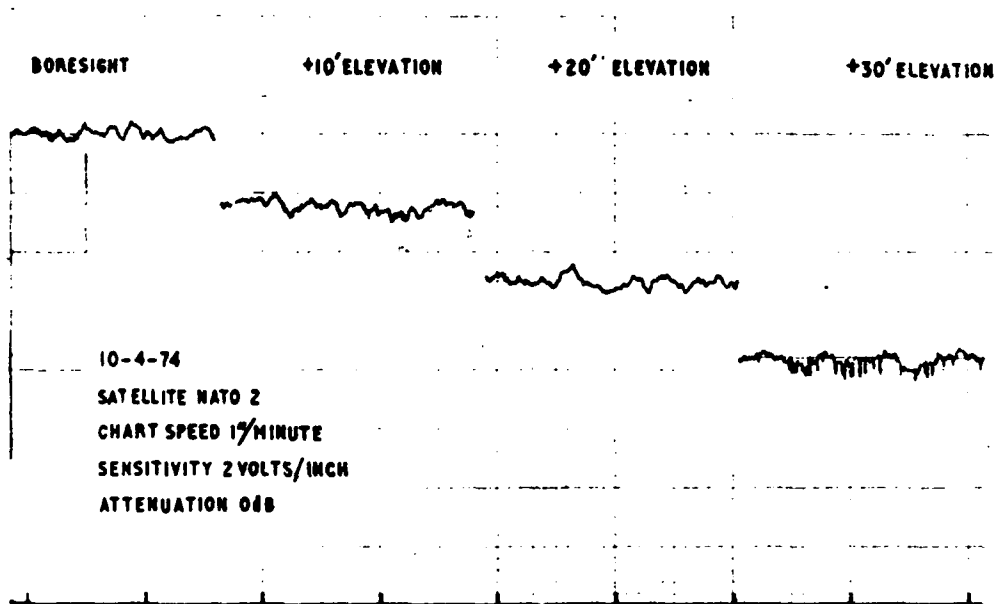

FIG. 15. SAMPLE OF ELEVATION CHANNEL OUTPUT RECORDING

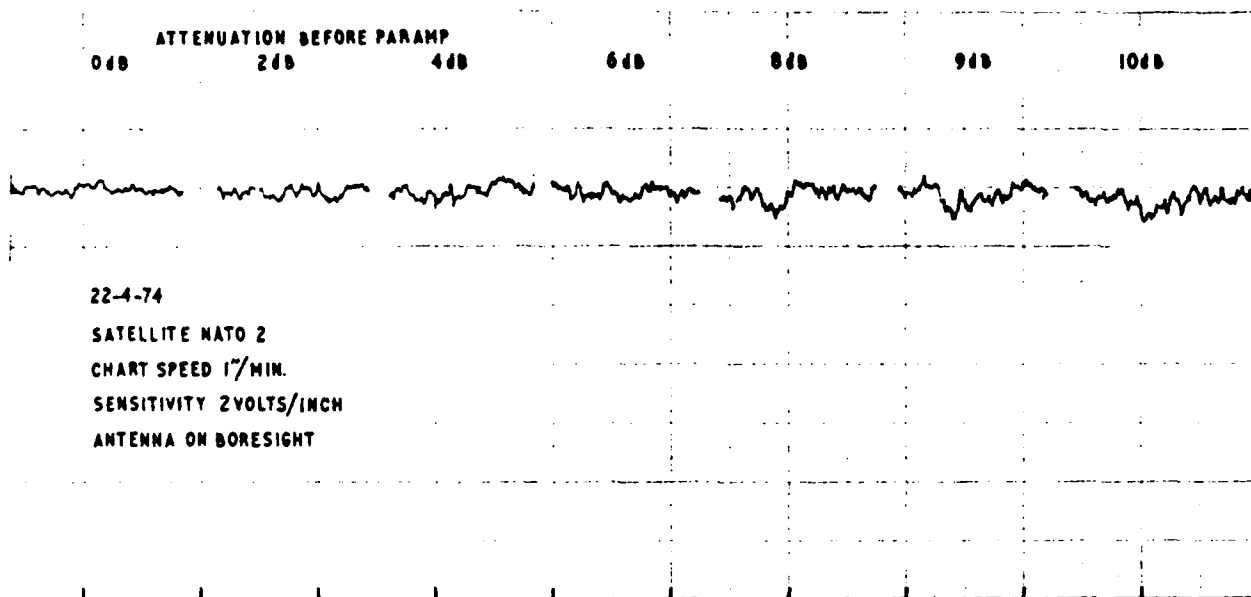

FIG. 16. ELEVATION ERROR CHANNEL OUTPUT SIGNAL Vs VARIATION OF DEMODULATOR INPUT LEVEL

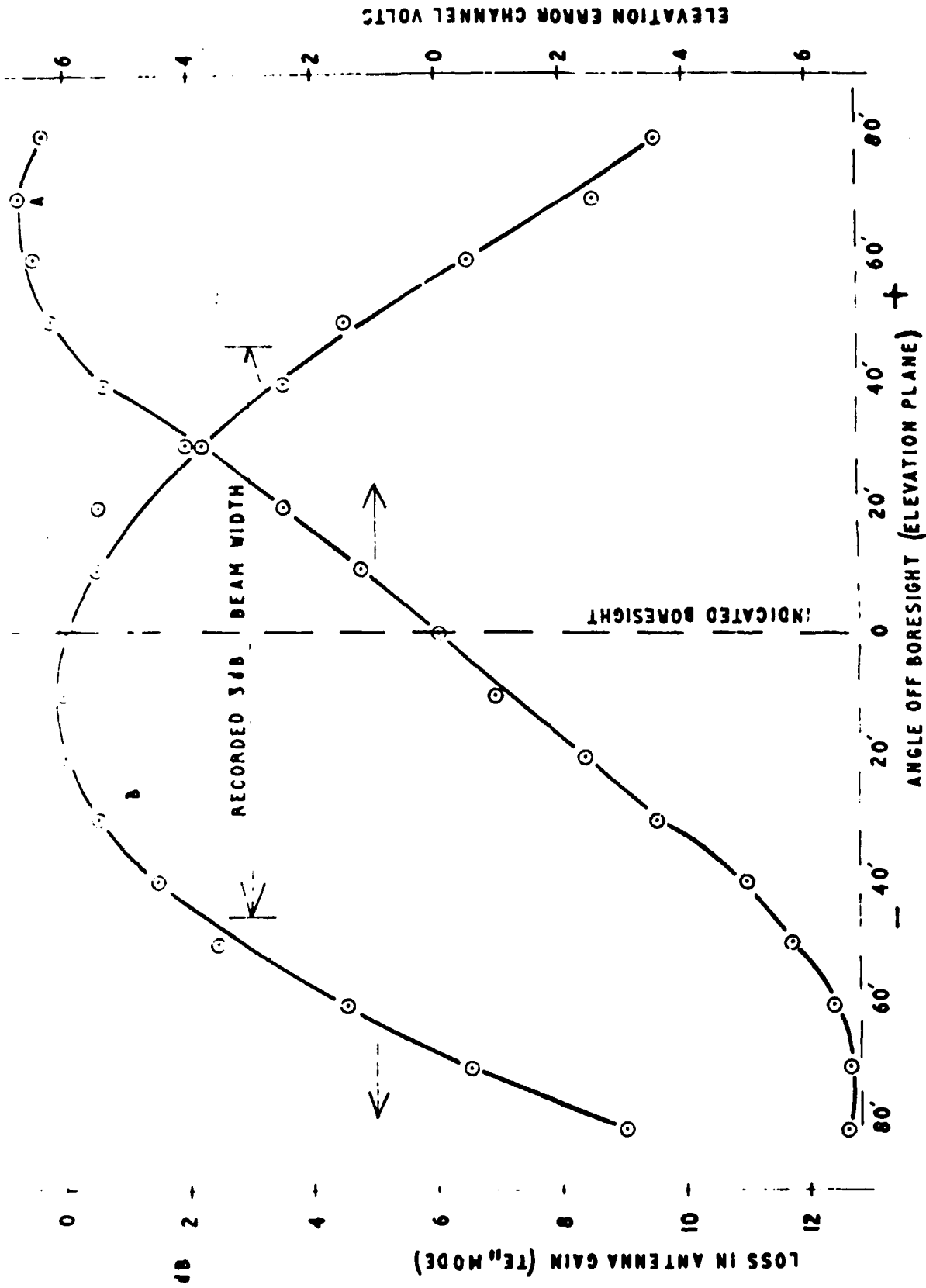

FIG. 17. ELEVATION ERROR CHANNEL VOLTAGE VS OFF BORESIGHT ANGLE (A)
 TE₁₁ MODE ANTENNA PATTERN SYMMETRY (B)

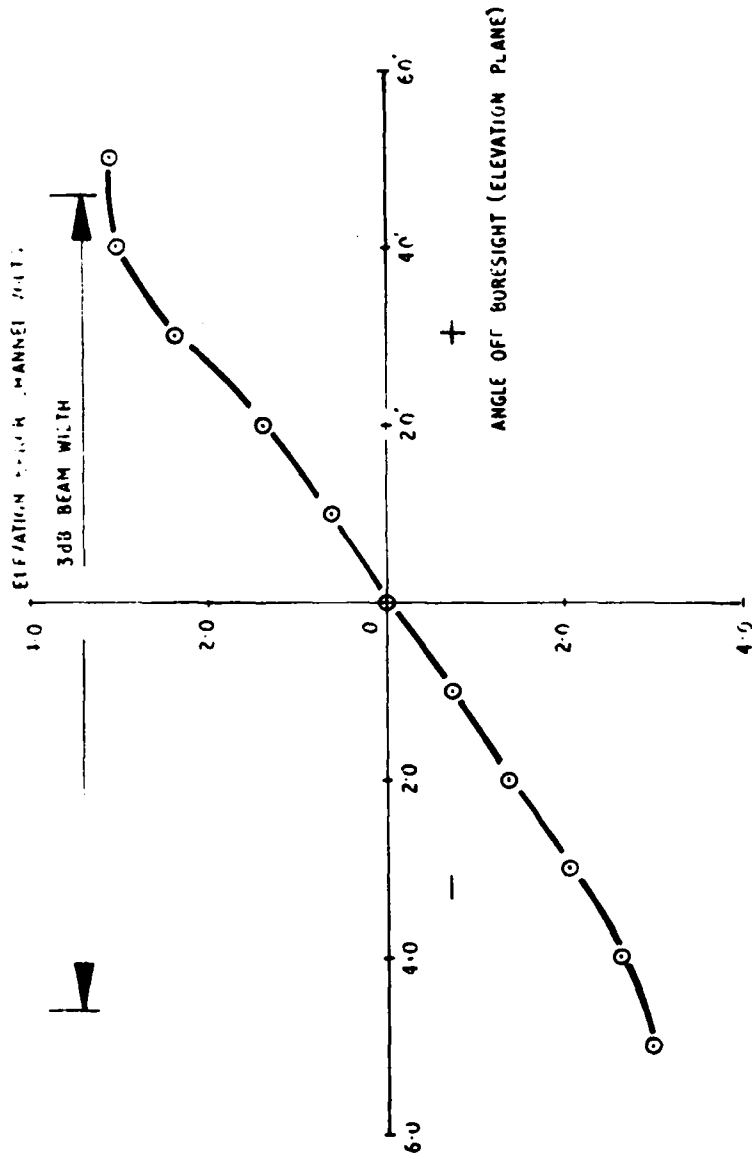

FIG 10. ELEVATION ERROR CHANNEL VOLTAGE V_S OFF BORESIGHT ANGLE
(6dB BEFORE PARAMP)

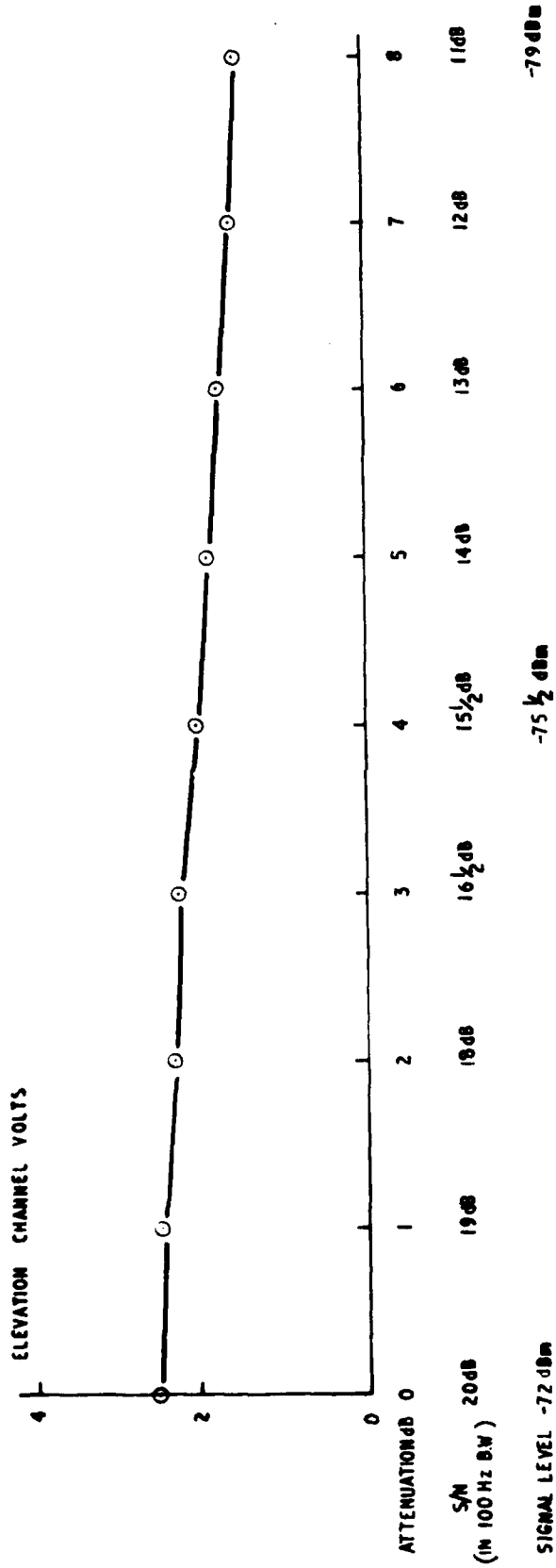

FIG. 19. CHANGE IN ELEVATION CHANNEL ERROR VOLTS WITH INPUT SIGNAL LEVEL

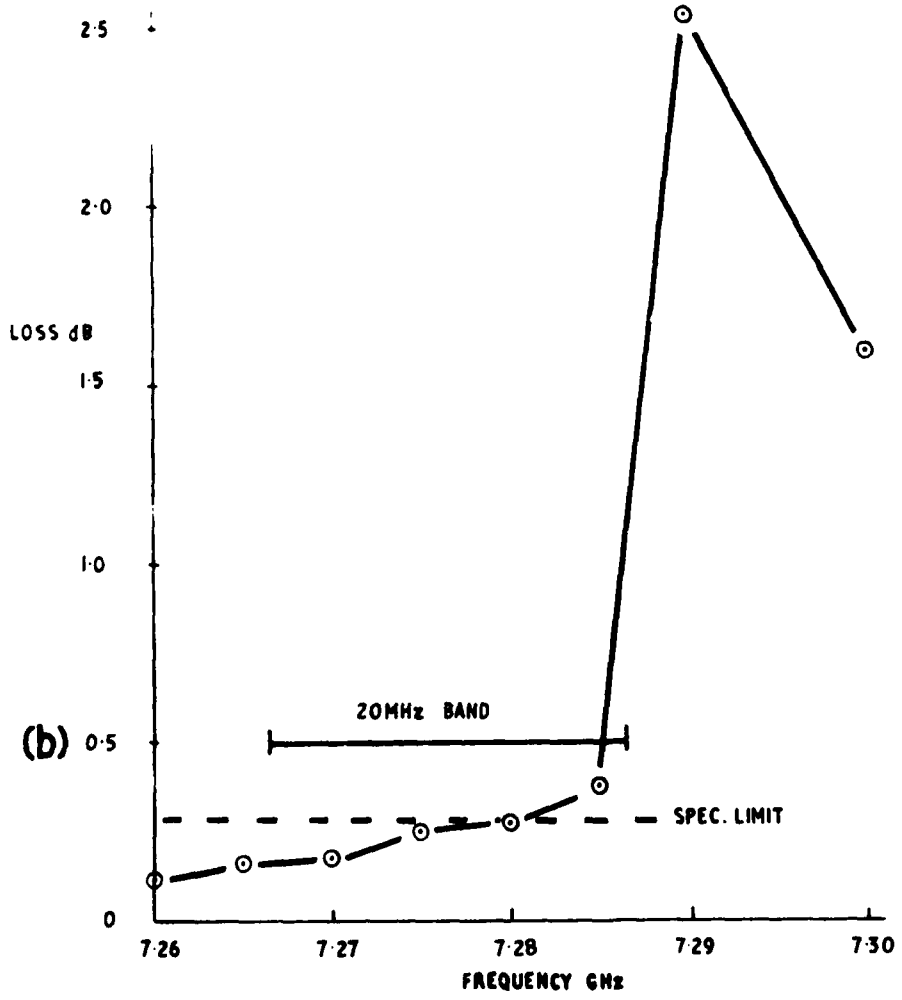
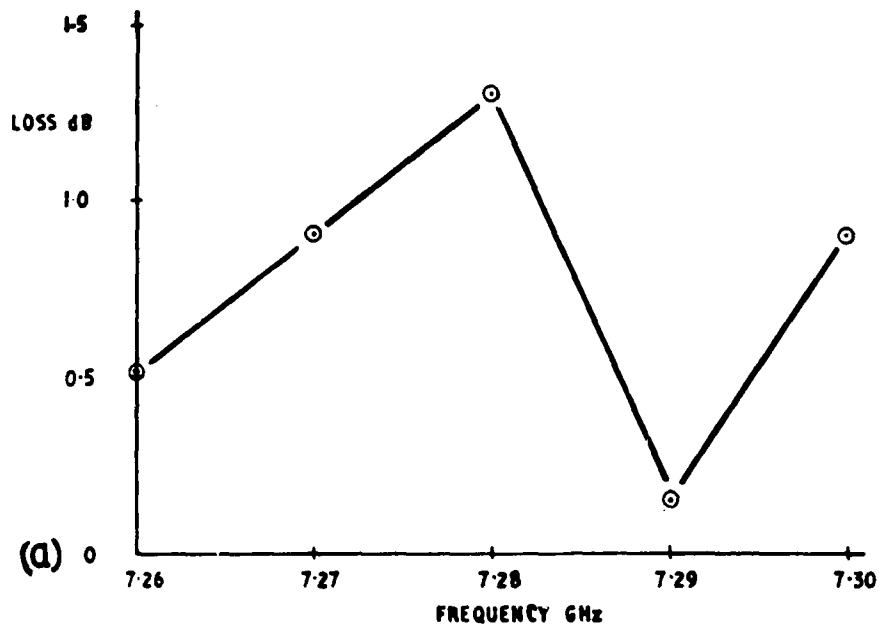

FIG 20. OHMIC LOSSES IN RECEIVE BAND

APPENDIX A

EQUIPMENT MODIFICATIONS CARRIED OUT AT SRDE TO IMPROVE SIGNAL ACQUISITION MARGIN

After initial setting up, the beacon signal of the satellite was acquired. By use of the microwave attenuator it was found that there was only a $1\frac{1}{4}$ dB signal margin on acquisition, the antenna requiring to be almost on boresight before the beacon signal was acquired. However, once acquired, the signal level could be reduced by approximately $3\frac{1}{2}$ dB before the tracking demodulator lost phase lock.

To increase the acquisition sensitivity the Marconi engineers proposed several modifications to the equipment. They were:

- i Reduction of the bandwidth of the demodulator tracking loop.
- ii Reduction of the sweep rate of the automatic beacon acquisition frequency search. This circuit swept ± 15 KHz in 5 seconds.
- iii Reduction of the loss of the tracking system at the beacon frequency.

A good match looking into the TE_{11} port of the hybrid T had been achieved in order to reinject the phase modulated TM_{01} mode energy back into the main circular guide as the TE_{11} mode, the path being the hybrid T and the mode coupler. By reciprocity a good match was provided in the reverse direction for TE_{11} mode energy at the beacon frequency. Analysis of the situation showed that when the horn was excited a quarter of the power was reflected back, half absorbed in the TE_{11} port (and ultimately by the isolator) and a quarter absorbed by the receive port. This produced an insertion loss of 6 dB (5.9 dB was measured by Marconi. Calculations showed that by suitably altering the match it was possible to reduce the insertion loss of the tracking system at the beacon frequency to 1.6 dB whilst reducing the level of the reinjected TM_{01} mode energy by only 2.6 dB. This loss could be tolerated due to the adequate error signal S/N ratio.

The above proposed changes were implemented as follows.

- i The loop bandwidth which was originally ± 100 Hz was reduced in steps. No appreciable increase in system performance was found with bandwidths less than ± 50 Hz. Reducing the bandwidth to ± 50 Hz gave an increase in S/N of 2.7 dB.
- ii The sweep period of the automatic beacon acquisition frequency search was increased from 5 to 14 seconds.
- iii The change in match was achieved by removing a single post matching section at the TE_{11} port of the hybrid T and replacing it by a 3 screw tuner. The tracking system was offset by about $\frac{1}{8}$ from a satellite and the 3 screw tuner was then adjusted to achieve maximum increase in beacon signal (as determined with a spectrum analyser) whilst not allowing the error meter reading to fall more than 2.6 dB below the reading shown when the single post section was in the waveguide assembly.

The above changes resulted in the signal acquisition margin being increased to approximately 12 dB. The increase in system acquisition range enabled the low powered IDCSP satellites to be acquired.

It was also noted that the various beacon frequencies were always within 1kHz of the nominal beacon frequency. The range of the automatic frequency search was therefore reduced to ± 5 kHz. This change reduced the acquisition time.

APPENDIX B

TARGET SPECIFICATION AMENDMENTS

The following amendments were made to the Target Specification in Ref 4 during the course of the contract to build the tracking system:

- | | | | |
|----|------------------------|--|---|
| a. | Original specification | Variation in indicated tracking error caused by + 10 dB change in signal strength. | 10% Max: |
| | Amended version | Variation in indicated tracking error caused by + <u>5</u> dB change in signal strength. | 10% Max: |
| b. | Original specification | Standing error between true TM_{01} null and indicated 'zero error'. | 3% FSD Max: |
| | Amended version | Standing error between true TM_{01} null and indicated 'zero error'. | Such as not to cause more than 0.1 dB loss in received communications signal. |

DOCUMENT CONTROL SHEET
(Notes on completion overleaf)

Overall security classification of sheetUnclassified.....

(As far as possible this sheet should contain only unclassified information. If it is necessary to enter classified information, the box concerned must be marked to indicate the classification eg (R),(C) or (S)).

1. DRIC Reference (if known) Not known	2. Originator's Reference 75 007	3. Agency Reference -	4. Report Security Classification Unclassified
5. Originator's Code (if known)	6. Originator (Corporate Author) Name and Location -		
5a. Sponsoring Agency's Code (if known) -	6a. Sponsoring Agency (Contract Authority) Name and Location -		
7. Title OPERATION AND PERFORMANCE OF A SIMPLE MULTIMODE TRACKING SYSTEM FOR SATELLITE COMMUNICATIONS			
7a. Title in Foreign Language (in the case of translations) -			
7b. Presented at (for conference papers). Title, place and date of conference -			
8. Author 1. Surname, initials CHIVERS M	9a. Author 2 -	9b. Authors 3, 4... -	10. Date pp ref 7.1975
11. Contract Number -	12. Period -	13. Project 5053	14. Other References -
15. Distribution statement Not limited			
Descriptors (or keywords) Aerial, amplitude, antenna, bandpass, beacon, circular, communications, coupler, demodulator, filter, mode, modulator, multimode, microwave, phase, polarisation, satellite, tracking, waveguide, sidebands, feed. continue on separate piece of paper if necessary			
Abstract The report gives an outline of the theory of operation of a simple microwave multimode aerial tracking system built under contract for SRDE. An account is presented of the tests performed on the system and the results obtained.			

DETACHABLE ABSTRACT CARDS

When a card is taken out, complete the appropriate space on the inside back cover. These cards are subject to the same security regulations as the parent document.

PROCUREMENT EXECUTIVE, MINISTRY OF DEFENCE
SIGNALS RESEARCH AND DEVELOPMENT ESTABLISHMENT

REPORT NO 75007

OPERATION AND PERFORMANCE OF A SIMPLE MULTIMODE
TRACKING SYSTEM FOR SATELLITE COMMUNICATIONS

M CHIVERS

SUMMARY

This report sets out the results of tests on a simple multimode microwave serial tracking system built under contract for SRDE. A description of the equipment and suggestion for an improved model are included. The system was found to operate very satisfactorily and in accordance with the specification.

July 1975

PROCUREMENT EXECUTIVE, MINISTRY OF DEFENCE
SIGNALS RESEARCH AND DEVELOPMENT ESTABLISHMENT

REPORT NO 75007

OPERATION AND PERFORMANCE OF A SIMPLE MULTIMODE
TRACKING SYSTEM FOR SATELLITE COMMUNICATIONS

M CHIVERS

SUMMARY

This report sets out the results of tests on a simple multimode microwave serial tracking system built under contract for SRDE. A description of the equipment and suggestion for an improved model are included. The system was found to operate very satisfactorily and in accordance with the specification.

July 1975

PROCUREMENT EXECUTIVE, MINISTRY OF DEFENCE
SIGNALS RESEARCH AND DEVELOPMENT ESTABLISHMENT

REPORT NO 75007

OPERATION AND PERFORMANCE OF A SIMPLE MULTIMODE
TRACKING SYSTEM FOR SATELLITE COMMUNICATIONS

M CHIVERS

SUMMARY

This report sets out the results of tests on a simple multimode microwave serial tracking system built under contract for SRDE. A description of the equipment and suggestion for an improved model are included. The system was found to operate very satisfactorily and in accordance with the specification.

July 1975