

AD-A279 799



0

FINAL REPORT
FEBRUARY 1994

REPORT NO. 94-15

EVALUATION OF 1-1/4- VERSUS
2-INCH METAL BANDING OF
500-POUND MK82 BOMBS ON
THE M127, M871, AND M872
SEMITRAILERS TRANSPORTABILITY
TESTS



DTIC
ELECTE
MAY 31 1994
S G D

1990 94-16070

Prepared for:
U.S. Army Defense Ammunition
Center and School
ATTN: SMCAC-DET
Savanna, IL 61074-9639

Distribution Unlimited



94 5 27 04 6

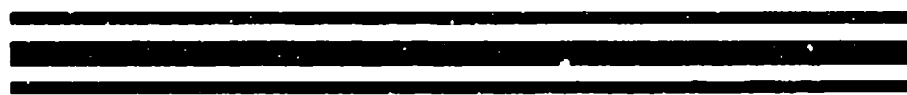

VALIDATION ENGINEERING DIVISION
SAVANNA, ILLINOIS 61074-9639

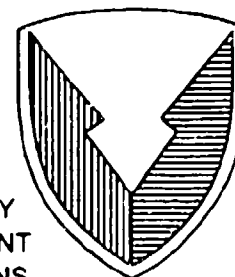

U.S. ARMY
ARMAMENT
MUNITIONS
CHEMICAL COMMAND
U.S. ARMY DEFENSE AMMUNITION
CENTER AND SCHOOL

AVAILABILITY NOTICE

A copy of this report will be furnished each attendee on automatic distribution. Additional copies or authority for reprinting may be obtained by written request from Director, U.S. Army Defense Ammunition Center and School, ATTN: SMCAC-DEV, Savanna, IL 61074-9639.

DISTRIBUTION INSTRUCTIONS

Destroy this report when no longer needed. Do not return.

Citation of trade names in this report does not constitute an official endorsement.

The information contained herein will not be used for advertising purposes.

Accession For	
NTIS CRA&I	<input checked="" type="checkbox"/>
DTIC TAB	<input type="checkbox"/>
Unannounced	<input type="checkbox"/>
Justification	
By	
Distribution/	
Availability Codes	
Dist	Avail and/or Special
A-1	

UNCLASSIFIED

SECURITY CLASSIFICATION OF THIS PAGE

REPORT DOCUMENTATION PAGE

Form Approved
OMB No. 0704-0188

1a. REPORT SECURITY CLASSIFICATION UNCLASSIFIED		1b. RESTRICTIVE MARKINGS	
2a. SECURITY CLASSIFICATION AUTHORITY		3. DISTRIBUTION / AVAILABILITY OF REPORT UNLIMITED	
2b. DECLASSIFICATION / DOWNGRADING SCHEDULE			
4. PERFORMING ORGANIZATION REPORT NUMBER(S) 94-15		5. MONITORING ORGANIZATION REPORT NUMBER(S)	
6a. NAME OF PERFORMING ORGANIZATION U.S. Army Defense Ammunition Center and School	6b. OFFICE SYMBOL <i>(if applicable)</i> SMCAC-DEV	7a. NAME OF MONITORING ORGANIZATION	
6c. ADDRESS <i>(City, State, and ZIP Code)</i> ATTN: SMCAC-DEV Savanna, IL 61074-9639		7b. ADDRESS <i>(City, State, and ZIP Code)</i>	
8a. NAME OF FUNDING / SPONSORING ORGANIZATION U.S. Army Defense Ammunition Center and School	8b. OFFICE SYMBOL <i>(if applicable)</i> SMCAC-DET	9. PROCUREMENT INSTRUMENT IDENTIFICATION NUMBER	
8c. ADDRESS <i>(City, State, and ZIP Code)</i> ATTN: SMCAC-DET Savanna, IL 61074-9639		10. SOURCE OF FUNDING NUMBERS	
		PROGRAM ELEMENT NO.	PROJECT NO.
		TASK NO.	WORK UNIT ACCESSION NO.
11. TITLE <i>(Include Security Classification)</i> Evaluation of 1-1/4- Versus 2-Inch Metal Banding of 500-Pound MK82 Bombs on the M127, M871, and M872 Semitrailers Transportability Tests			
12. PERSONAL AUTHOR(S) A. C. McIntosh, Jr.			
13a. TYPE OF REPORT Final	13b. TIME COVERED FROM _____ TO _____	14. DATE OF REPORT <i>(Year, Month, Day)</i> 1994 February	15. PAGE COUNT
16. SUPPLEMENTARY NOTATION			
17. COSATI CODES		18. SUBJECT TERMS <i>(Continue on reverse if necessary and identify by block number)</i>	
FIELD	GROUP	SUB-GROUP	
19. ABSTRACT <i>(Continue on reverse if necessary and identify by block number)</i>			
<p>The U.S. Army Defense Ammunition Center and School (USADACS), Validation Engineering Division (SMCAC-DEV), was tasked by USADACS, Transportation Engineering Division (SMCAC-DET), to evaluate the substitution of 1-1/4-inch metal banding in lieu of 2-inch metal banding in the road transportation of 500-pound MK82 bombs on M127, M871, and M872 semitrailers. The substitution is due to the nonavailability of 2-inch metal banding and the 2-inch metal banding being difficult to work with in the preparation of ammunition loads. Currently, two 2-inch metal bands are used to secure a load unit of two pallets of 500-pound MK82 bombs to a flatbed semitrailer for road transportation. These tests are to investigate the use of three 1-1/4-inch metal bands to secure 500-pound MK82 bombs to the M127, M871, and M872 semitrailers during road transportation. These tests document the load securing ability of three 1-1/4-inch metal bands versus two 2-inch metal bands.</p>			
20. DISTRIBUTION / AVAILABILITY OF ABSTRACT <input checked="" type="checkbox"/> UNCLASSIFIED/UNLIMITED <input type="checkbox"/> SAME AS RPT. <input type="checkbox"/> DTIC USER.		21. ABSTRACT SECURITY CLASSIFICATION UNCLASSIFIED	
22a. NAME OF RESPONSIBLE INDIVIDUAL JEROME H. KROHN		22b. TELEPHONE <i>(Include Area Code)</i> 815-273-8929	22c. OFFICE SYMBOL SMCAC-DEV

U.S. ARMY DEFENSE AMMUNITION CENTER AND SCHOOL
VALIDATION ENGINEERING DIVISION
SAVANNA, IL 61074-9639

REPORT NO. 94-15

EVALUATION OF 1-1/4- VERSUS 2-INCH METAL BANDING OF 500-POUND
MK82 BOMBS ON THE M127, M871, AND M872 SEMITRAILERS
TRANSPORTABILITY TESTS

FEBRUARY 1994

TABLE OF CONTENTS

PART	PAGE NO.
1. INTRODUCTION	1-1
A. BACKGROUND	1-1
B. AUTHORITY	1-1
C. OBJECTIVE	1-1
D. CONCLUSION	1-1
E. RECOMMENDATION	1-2
2. ATTENDEES	2-1
3. TEST PROCEDURES	3-1
4. TEST RESULTS	4-1
5. DRAWINGS	5-1

PART 1

INTRODUCTION

A. **BACKGROUND**. The U.S. Army Defense Ammunition Center and School (USADACS), Validation Engineering Division (SMCAC-DEV), was tasked by USADACS, Transportation Engineering Division (SMCAC-DET), to evaluate the substitution of 1-1/4-inch metal banding in lieu of 2-inch metal banding in the road transportation of 500-pound MK82 bombs on the M127, M871, and M872 semitrailers. The substitution is due to the nonavailability of 2-inch metal banding and the 2-inch metal banding being difficult to work with in the preparation of ammunition loads. Currently, two 2-inch metal bands are used to secure a load unit of two pallets of 500-pound MK82 bombs to a flatbed semitrailer for road transportation. By using three 1-1/4-inch metal bands, the same load securing ability is achieved.

B. **AUTHORITY**. This test was conducted IAW mission responsibilities delegated by U.S. Army Armament, Munitions and Chemical Command (AMCCOM), Rock Island, IL 61299-6000. Reference is made to Change 4, 4 October 1974, to AR 740-1, 23 April 1971, Storage and Supply operations; AMCCOMR 10-17, 13 January 1986, Mission and Major Functions of U.S. Army Defense Ammunition Center and School (USADACS).

C. **OBJECTIVE**. The objective of these tests is to validate the concept of using three 1-1/4-inch metal bands in place of two 2-inch metal bands in securing two pallets of 500-pound MK82 bombs to the M127, M871, and M872 semitrailers for road transportation. The test requirements are set forth in TP-91-01, Transportability Testing Procedures, July 1991.

D. **CONCLUSION**. After subjecting all test loads to the road hazard course and the 30-mile road trip and panic stops, no movement in any loads were observed and no loosening of the 1-1/4-inch metal banding was observed. One metal band slipped off a pallet loaded on the

M871 semitrailer at the end of the second pass over the road hazard course. The load proceeded over the washboard course with 1-inch forward movement. The banding was placed over the pallet at a dimension of less than 3-1/2 inches from the top pallet edge.

E. RECOMMENDATION. Recommend three 1-1/4-inch metal bands be used to secure two 500-pound MK82 bombs to the M127, M871, and M872 semitrailers for road transportation provided that the banding is 3-1/2 inches or more from the top edge of the pallet.

PART 2

22 FEBRUARY AND 21-23 MARCH 1994

ATTENDEES

A. C. McIntosh
General Engineer
DSN 585-8989
815-273-8989

Director
U.S. Army Defense Ammunition Center
and School
ATTN: SMCAC-DEV
Savanna, IL 61074-9639

Ralph H. Arnold
Industrial Engineering Technician
DSN 585-8073
815-273-8073

Director
U.S. Army Defense Ammunition Center
and School
ATTN: SMCAC-DET
Savanna, IL 61074-9639

Jerome H. Krohn
Supervisory General Engineer
DSN 585-8908
815-273-8908

Director
U.S. Army Defense Ammunition Center
and School
ATTN: SMCAC-DEV
Savanna, IL 61074-9639

PART 3

TEST PROCEDURES

These procedures were extracted from TP-91-01, Transportability Testing Procedures, July 1991, for tactical vehicles used for shipping munitions by tactical truck.

A. All test loads were prepared using the drawing specified for the munitions (see part 5). The 500-pound MK82 bombs used in all loads were inert (nonexplosive). The weight and physical characteristics of the load configuration for all tests were identical to the live (explosive) ammunition provided for in the drawing in part 5; i.e., weights, physical dimensions, center of gravity (CG), etc.

B. Tests for this load configuration are as follows:

1. Road Hazard Course (Test Method No. 2).
2. Road Trip (Test Method No. 3).
3. Road Hazard Course (Test Method No. 2).
4. Washboard Course (Test Method No. 6).

C. The test methods are as follows:

1. Test Method No. 2 (Road Hazard Course). This method required the bomb loaded semitrailer be pulled over the 200-foot-long segment of concrete-paved road which consists of two series of railroad ties projecting 6-inches above the level road surface. The semitrailer traversed this course two times. The road hazard course is constructed as shown in Figure 1, page 3-3.

2. Test Method No. 3 (Road Trip). The semitrailer transported two pallets of MK82 bombs for a distance of 30 miles over a combination of roads surfaced with gravel, concrete, or asphalt. The test route included curves, corners, railroad crossings, cattle guards, and stops and starts. The load traveled at the maximum speed suitable for the particular road being traversed, except as limited by legal restrictions. Upon completion of the 30-mile road trip, the load was subjected to three full airbrake stops while traveling in the forward direction and one in the reverse direction. The first three stops were at 5, 10, 15mph, while the stop in the reverse direction was approximately 5mph.

3. Test Method No. 6 (Washboard Course). Each trailer load was driven over the washboard course at a speed that produced the most violent response of the vehicle. The washboard course is constructed as shown in Figure 2, page 3-4.

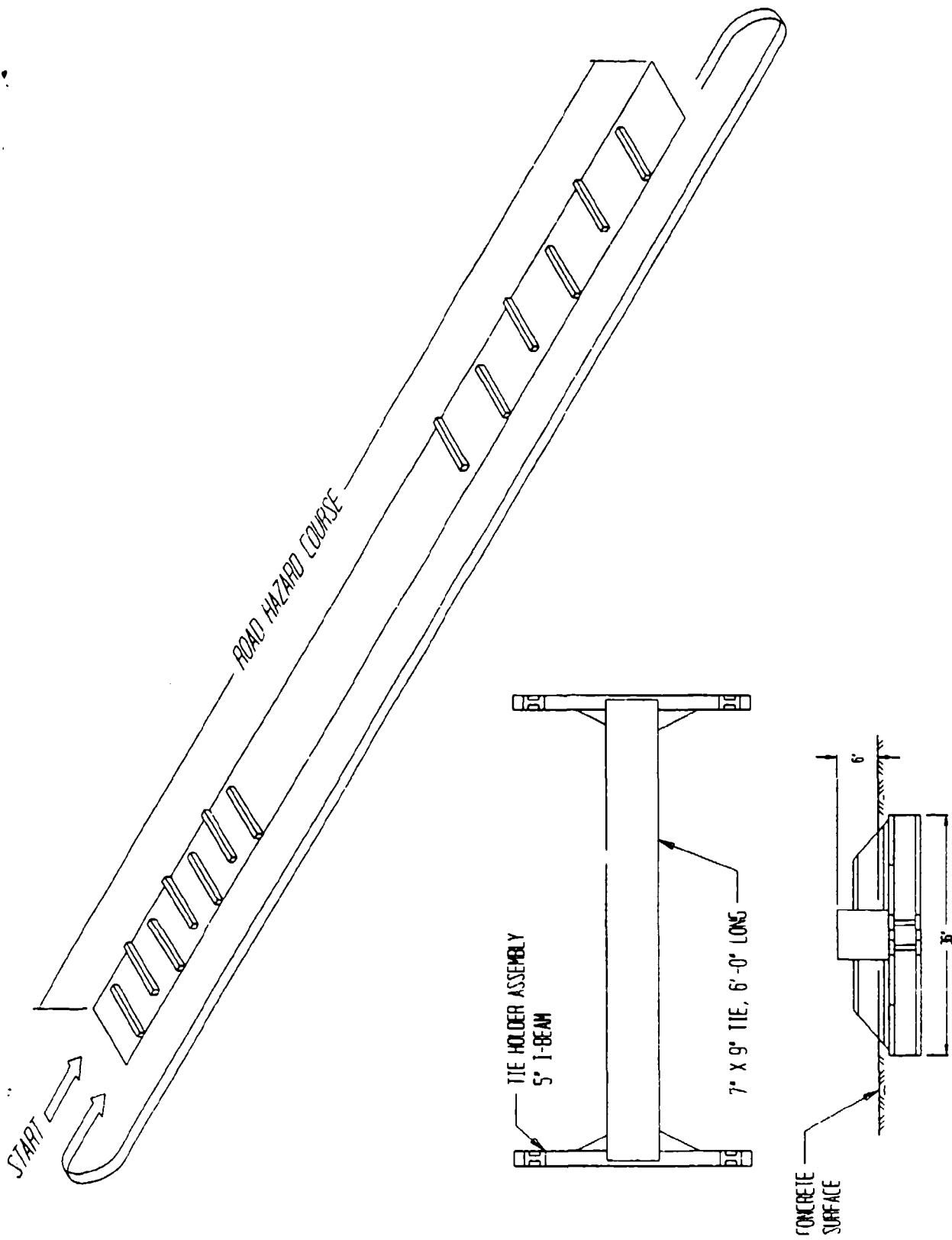

FIGURE 1

TIE HOLDER DETAILS

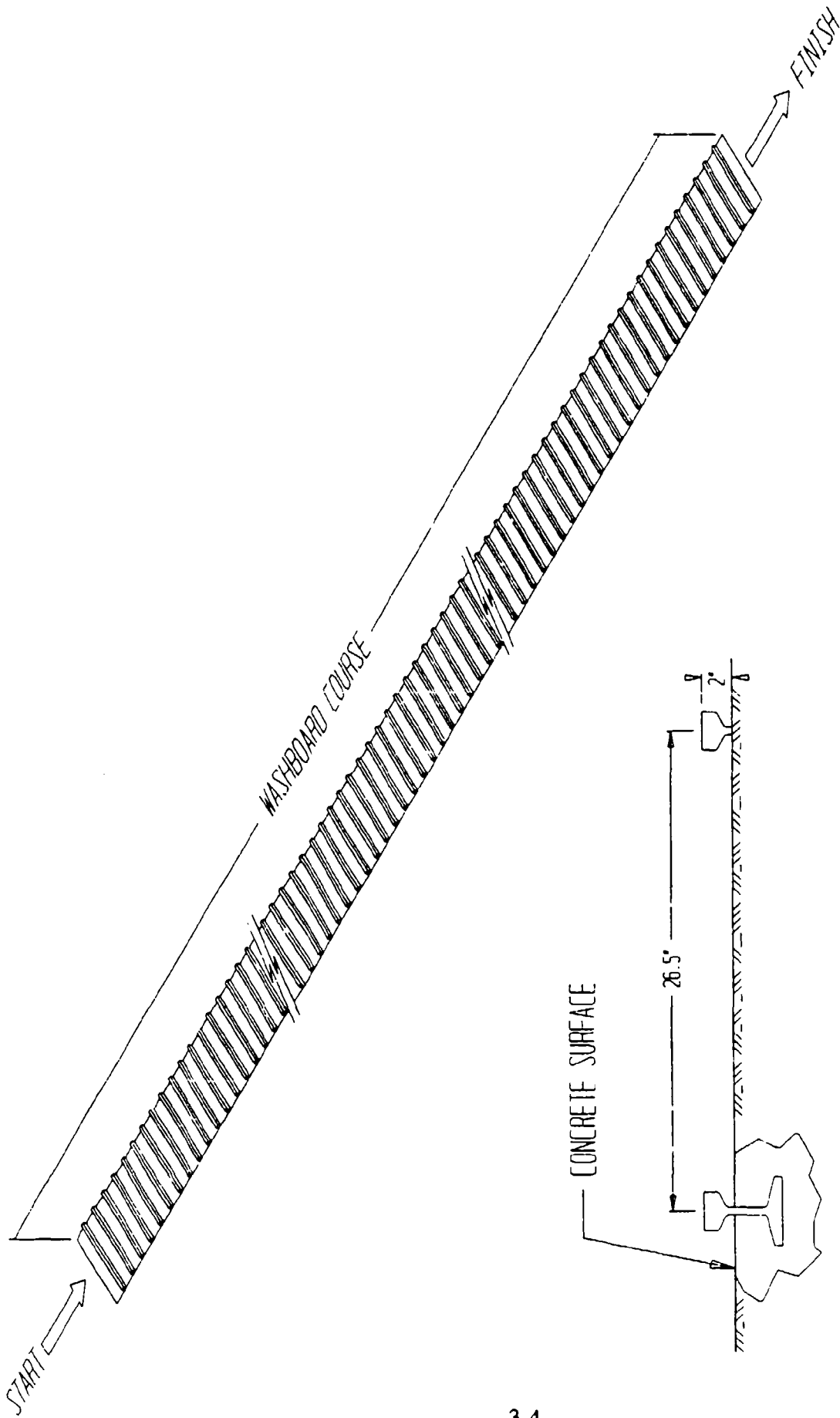

FIGURE 2

PART 4

TEST RESULTS

ROAD TEST DATA

Test No.: 1

Date: 22 February 1994

Specimen Load: Two pallets of 500-pound MK82 bombs on an M127 semitrailer.

ROAD HAZARD COURSE:

PASS 1-A OVER FIRST SERIES OF TIES: 6.08 SEC 5.6 MPH

PASS 1-B OVER SECOND SERIES OF TIES: 6.29 SEC 5.2 MPH

REMARKS: No damage to the semitrailer or load movement.

PASS 2-A OVER FIRST SERIES OF TIES: 6.89 SEC 4.9 MPH

PASS 2-B OVER SECOND SERIES OF TIES: 6.42 SEC 5.1 MPH

REMARKS: No damage or load movement.

30-MILE ROAD TEST: No damage or load movement.

PANIC STOP TEST: At 5, 10, and 15 mph in the forward direction and 5 mph in reverse; no load movement or damage.

PASS 3-A OVER FIRST SERIES OF TIES: 6.20 SEC 5.5 MPH

PASS 3-B OVER SECOND SERIES OF TIES: 6.53 SEC 5.0 MPH

REMARKS: No load movement. Rear wheels fell off the M127 semitrailer. Test stopped.

ROAD TEST DATA

Test No.: 2

Date: 21 March 1994

Specimen Load: Two pallets of 500-pound MK82 bombs on an M871 semitrailer.

ROAD HAZARD COURSE:

PASS 1-A OVER FIRST SERIES OF TIES: 6.72 SEC 5.1 MPH

PASS 1-B OVER SECOND SERIES OF TIES: 6.85 SEC 4.8 MPH

REMARKS: No damage to the semitrailer or load movement.

PASS 2-A OVER FIRST SERIES OF TIES: 6.54 SEC 5.2 MPH

PASS 2-B OVER SECOND SERIES OF TIES: 6.18 SEC 5.3 MPH

REMARKS: No damage or load movement.

30-MILE ROAD TEST: No damage or load movement.

PANIC STOP TEST: At 5, 10, and 15 mph in the forward direction and 5 mph in reverse; no load movement or damage.

PASS 3-A OVER FIRST SERIES OF TIES: 6.32 SEC 5.4 MPH

PASS 3-B OVER SECOND SERIES OF TIES: 6.93 SEC 4.7 MPH

REMARKS: No damage or load movement.

PASS 4-A OVER FIRST SERIES OF TIES: 6.10 SEC 5.6 MPH

PASS 4-B OVER SECOND SERIES OF TIES: 6.49 SEC 5.0 MPH

REMARKS: The rear band holding the MK82 pallets to the truck slipped off the pallet. Reason: the bands were initially placed less than 3 1/2-inches from the edge of the pallet top. No pallet damage.

WASHBOARD COURSE: The pallets slid approximately 1-inch forward during the pass over the washboard course. No pallet damage.

ROAD TEST DATA

Test No.: 3

Date: 22 March 1994

Specimen Load: Two pallets of 500-pound MK82 bombs on an M872 semitrailer.

ROAD HAZARD COURSE:

PASS 1-A OVER FIRST SERIES OF TIES: 6.50 SEC 5.2 MPH

PASS 1-B OVER SECOND SERIES OF TIES: 6.21 SEC 5.3 MPH

REMARKS: No damage to the semitrailer or load movement.

PASS 2-A OVER FIRST SERIES OF TIES: 6.07 SEC 5.6 MPH

PASS 2-B OVER SECOND SERIES OF TIES: 6.09 SEC 5.4 MPH

REMARKS: No damage or load movement.

30-MILE ROAD TEST: No damage or load movement.

PANIC STOP TEST: At 5, 10, and 15 mph in the forward direction and 5 mph in reverse; no load movement or damage.

PASS 3-A OVER FIRST SERIES OF TIES: 6.36 SEC 5.4 MPH

PASS 3-B OVER SECOND SERIES OF TIES: 6.06 SEC 5.4 MPH

REMARKS: No damage or load movement.

PASS 4-A OVER FIRST SERIES OF TIES: 6.20 SEC 5.5 MPH

PASS 4-B OVER SECOND SERIES OF TIES: 6.55 SEC 5.0 MPH

REMARKS: No damage to the pallets. The driver's side pallet moved 1/4-inch forward and 1/4-inch to the outside of the semitrailer. The curb side of the pallet moved 1/2-inch forward with no lateral movement.

WASHBOARD COURSE: No pallet damage or load movement.

ROAD TEST DATA

Test No.: 4

Date: 23 March 1994

Specimen Load: Two pallets of 500-pound MK82 bombs on an M127 semitrailer.

ROAD HAZARD COURSE:

PASS 1-A OVER FIRST SERIES OF TIES: 6.00 SEC 5.6 MPH

PASS 1-B OVER SECOND SERIES OF TIES: 6.78 SEC 4.8 MPH

REMARKS: No damage to the semitrailer or load movement.

PASS 2-A OVER FIRST SERIES OF TIES: 6.98 SEC 4.9 MPH

PASS 2-B OVER SECOND SERIES OF TIES: 6.17 SEC 5.3 MPH

REMARKS: No damage or load movement.

30-MILE ROAD TEST: No damage or load movement.

PANIC STOP TEST: At 5, 10, and 15 mph in the forward direction and 5 mph in reverse; no load movement or damage.

PASS 3-A OVER FIRST SERIES OF TIES: 6.07 SEC 5.6 MPH

PASS 3-B OVER SECOND SERIES OF TIES: 6.83 SEC 4.7 MPH

REMARKS: No damage or load movement.

PASS 4-A OVER FIRST SERIES OF TIES: 6.81 SEC 5.0 MPH

PASS 4-B OVER SECOND SERIES OF TIES: 6.30 SEC 5.2 MPH

REMARKS: No damage to the pallets or load movement.

WASHBOARD COURSE: No pallet damage. The driver side pallet moved 3/4-inch forward and the curb side pallet moved forward 1/2-inch. No measurable lateral movement was observed.

PART 5

DRAWINGS

STEEL STRAP, 1 1/4" X .035" OR .031" X 20'-0" (3 REQ'D). INSTALL FROM TWO 10'-0"-LONG PIECES.

SEAL FOR 1 1/4" STRAP (18 REQ'D, 6 PER STRAP). DOUBLE NOTCH.

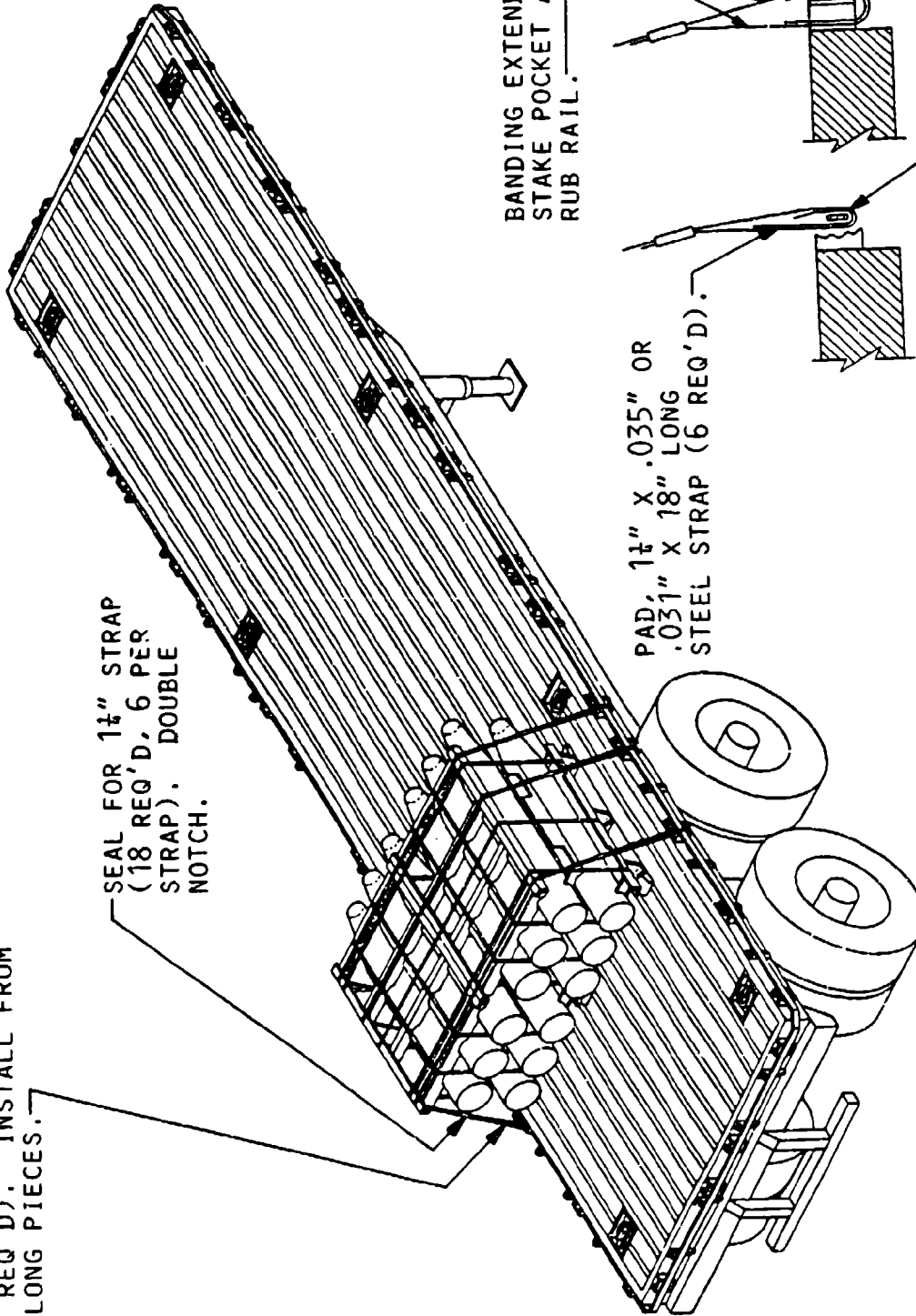

BANDING EXTENDS THROUGH STAKE POCKET AND AROUND RUB RAIL.

PAD, 1 1/4" X .035" OR .031" X 18" LONG STEEL STRAP (6 REQ'D).

BANDING ENCIRCLES TRAILER RUB RAIL.

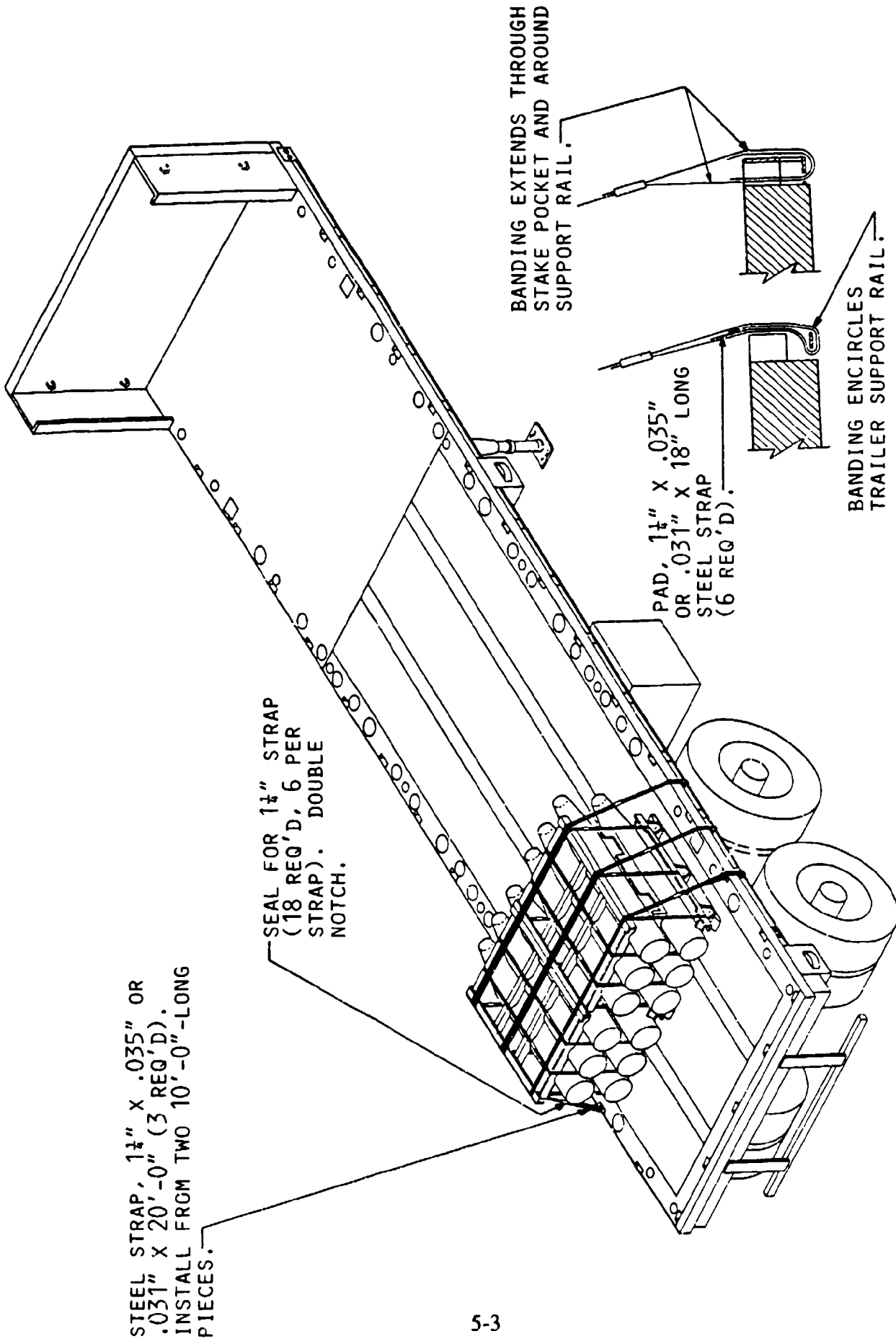

STEEL STRAP, 1 1/2" X .035" OR .031" X 20'-0" (3 REQ'D). INSTALL FROM TWO 10'-0"-LONG PIECES.

SEAL FOR 1 1/2" STRAP (18 REQ'D, 6 PER STRAP). DOUBLE NOTCH.

BANDING EXTENDS THROUGH STAKE POCKET AND AROUND SUPPORT RAIL.

PAD, 1 1/2" X .035" OR .031" X 18" LONG STEEL STRAP (6 REQ'D).

BANDING ENCIRCLES TRAILER SUPPORT RAIL.

TWO PALLETS OF 500-POUND MK82 BOMBS ON AN M871 SEMITRAILER

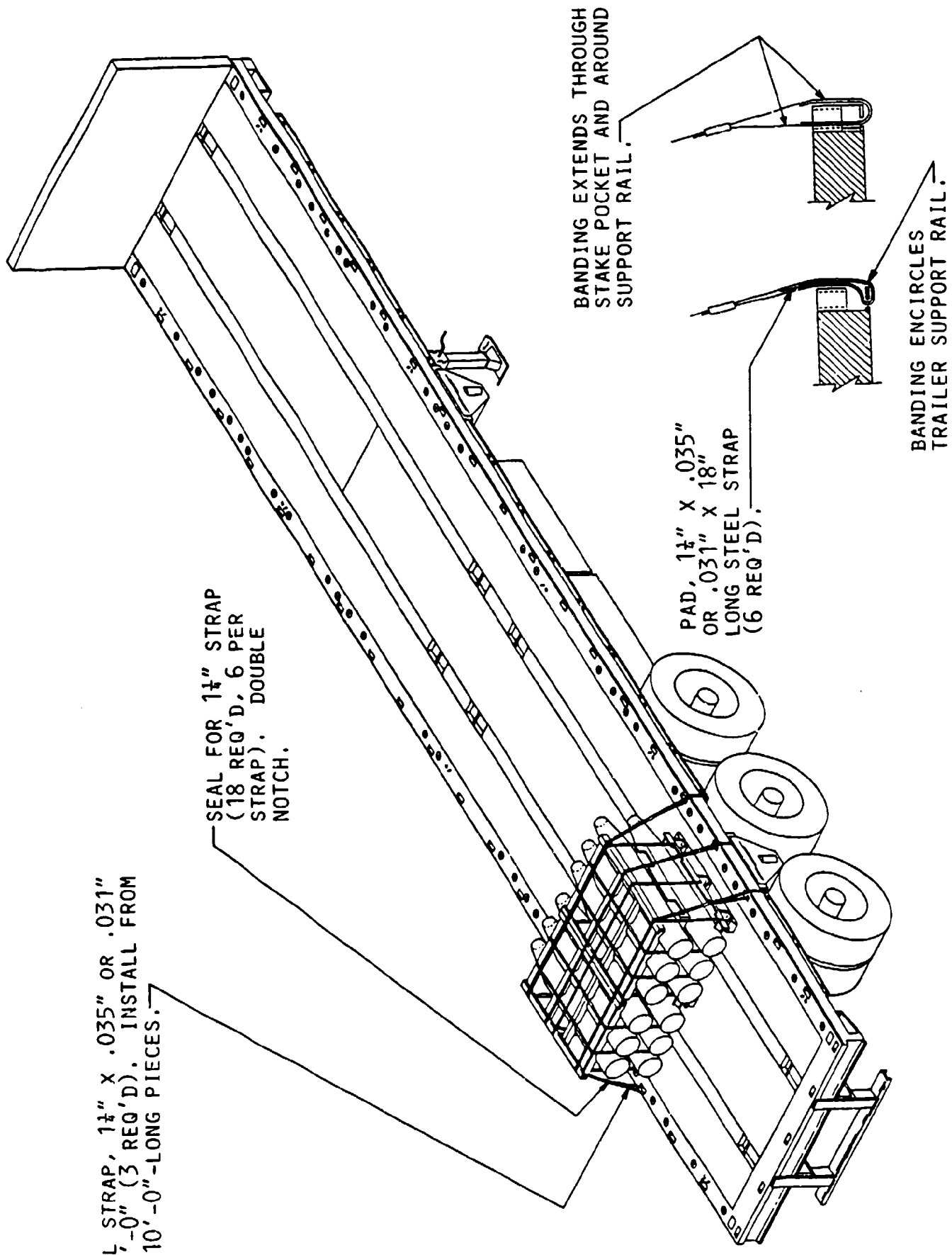

TWO PALLETS OF 500-POUND MK82 BOMBS ON AN M872 SEMITRAILER