

AD-A280 236



AD

TECHNICAL REPORT ARCCB-TR-94011

CHROMIUM/MOLYBDENUM ALLOY PLATING

PART I: THE ELECTRODEPOSITION OF LOW CONTRACTION CHROMIUM/MOLYBDENUM ALLOYS USING UNIPOLAR (ON/OFF) PULSE PLATING

MARK D. MILLER
STEPHEN LANGSTON

DTIC
ELECTE
JUN 14 1994
S G D

MARCH 1994



US ARMY ARMAMENT RESEARCH,
DEVELOPMENT AND ENGINEERING CENTER
CLOSE COMBAT ARMAMENTS CENTER
BENÉT LABORATORIES
WATERVLIET, N.Y. 12189-4050



APPROVED FOR PUBLIC RELEASE; DISTRIBUTION UNLIMITED

94-18225



19126

94 6 13 117

DISCLAIMER

The findings in this report are not to be construed as an official Department of the Army position unless so designated by other authorized documents.

The use of trade name(s) and/or manufacturer(s) does not constitute an official indorsement or approval.

DESTRUCTION NOTICE

For classified documents, follow the procedures in DoD 5200.22-M, Industrial Security Manual, Section II-19 or DoD 5200.1-R, Information Security Program Regulation, Chapter IX.

For unclassified, limited documents, destroy by any method that will prevent disclosure of contents or reconstruction of the document.

For unclassified, unlimited documents, destroy when the report is no longer needed. Do not return it to the originator.

REPORT DOCUMENTATION PAGE

Form Approved
OMB No. 0704-0188

Public reporting burden for this collection of information is estimated to average 1 hour per response, including the time for reviewing instructions, searching existing data sources, gathering and maintaining the data needed, and completing and reviewing the collection of information. Send comments regarding this burden estimate or any other aspect of this collection of information, including suggestions for reducing this burden, to Washington Headquarters Services, Directorate for Information Operations and Reports, 1215 Jefferson Davis Highway, Suite 1204, Arlington, VA 22202-4302, and to the Office of Management and Budget, Paperwork Reduction Project (0704-0188), Washington, DC 20503.

1. AGENCY USE ONLY (Leave blank)	2. REPORT DATE March 1994	3. REPORT TYPE AND DATES COVERED Final
----------------------------------	------------------------------	---

4. TITLE AND SUBTITLE CHROMIUM/MOLYBDENUM ALLOY PLATING PART I: THE ELECTRODEPOSITION OF LOW CONTRACTION CHROMIUM/ MOLYBDENUM ALLOYS USING UNIPOLAR (ON/OFF) PULSE PLATING	5. FUNDING NUMBERS AMCMS: 6111.02.H611.1
---	---

6. AUTHOR(S) Mark D. Miller and Stephen Langston	
---	--

7. PERFORMING ORGANIZATION NAME(S) AND ADDRESS(ES) U.S. Army ARDEC Benét Laboratories, SMCAR-CCB-TL Watervliet, NY 12189-4050	8. PERFORMING ORGANIZATION REPORT NUMBER ARCCB-TR-94011
--	---

9. SPONSORING / MONITORING AGENCY NAME(S) AND ADDRESS(ES) U.S. Army ARDEC Close Combat Armaments Center Picatinny Arsenal, NJ 07801-5000	10. SPONSORING / MONITORING AGENCY REPORT NUMBER
---	---

11. SUPPLEMENTARY NOTES

12a. DISTRIBUTION / AVAILABILITY STATEMENT Approved for public release; distribution unlimited	12b. DISTRIBUTION CODE
---	------------------------

13. ABSTRACT (Maximum 200 words)

The microstructure and mechanical properties of a pulse-plated low contraction (LC) chromium/molybdenum (Cr/Mo) alloy deposit were evaluated and compared to both pulse-plated LC chromium and direct (dc)-plated LC chromium. Molybdenum concentrations as high as approximately 2.4 percent were obtained at a pulsing frequency of 5 Hz (100 ms on-time/100 ms off-time). This represents nearly a 300 percent increase over the percent molybdenum obtained in a dc-plated LC Cr/Mo alloy deposit. However, pulse-plated LC Cr/Mo deposits were generally poor in quality with deposits that were frequently cracked and nodular in appearance. Hardness values as high as 900 KHN (50 gm load) were obtained for the pulse-plated LC Cr/Mo alloy deposits. This hardness represents an 18 percent increase over the maximum reported hardness obtained in a dc-plated LC chromium deposit. The maximum cathode current efficiency (CCE) obtained while pulse plating an LC Cr/Mo alloy was 7.3 percent. This is nearly 52 percent less than the reported CCE obtained when dc plating LC chromium.

14. SUBJECT TERMS Chromium/Molybdenum Alloy, Aqueous, Pulse, Electrodeposition	15. NUMBER OF PAGES 13
	16. PRICE CODE

17. SECURITY CLASSIFICATION OF REPORT UNCLASSIFIED	18. SECURITY CLASSIFICATION OF THIS PAGE UNCLASSIFIED	19. SECURITY CLASSIFICATION OF ABSTRACT UNCLASSIFIED	20. LIMITATION OF ABSTRACT U1
--	---	--	--------------------------------------

TABLE OF CONTENTS

ACKNOWLEDGEMENTS	ii
INTRODUCTION	1
EXPERIMENTAL PROCEDURE	1
RESULTS AND DISCUSSION	2
CONCLUSIONS	4
REFERENCES	5

List of Illustrations

1. Schematic diagram of the pulse plating cell used to electrodeposit LC Cr/Mo alloy	6
2. The frequency and duty cycle for each on-time/off-time condition evaluated during the pulse electrodeposition of LC Cr/Mo alloys	7
3. The energy dispersive x-ray analysis of the LC Cr/Mo alloy at (a) 5 Hz (100 ms on/100 ms off) and (b) 50 Hz (10 ms on/10 ms off)	8
4. The effects of pulse plating on the (a) hardness and (b) CCE of the LC Cr/Mo electrodeposits	9
5. The topographical photomicrographs of pulse-plated LC Cr/Mo electrodeposits	10
6. SEM photomicrographs of the cross-sectional microstructure of LC Cr/Mo alloy electrodeposited using pulse plating	11

Accession For	
NTIS CRA&I	<input checked="" type="checkbox"/>
DTIC TAB	<input type="checkbox"/>
Unannounced	<input type="checkbox"/>
Justification	
By	
Distribution /	
Availability Codes	
Dist	Avail and/or Special
A-1	

ACKNOWLEDGEMENTS

The authors wish to express their appreciation to C. Rickard and A. Kapusta of Benét Laboratories for their metallographic data.

INTRODUCTION

A chromium/molybdenum (Cr/Mo) alloy electrodeposit is very desirable because of its reported benefits including improved wear, corrosion, and erosion resistance compared to conventional chromium deposits (refs 1-3). Bing et al. (ref 4) have found that a Cr/Mo alloy electrodeposit possessed better tribological characteristics than pure chromium electrodeposits (ref 4). Brenner (ref 5) has reported that the Cr/Mo alloy did not have the network of cracks characteristic of the unalloyed chromium deposit and, in addition, the Cr/Mo codeposit lasted from three to eight times longer in wear tests than pure chromium deposits.

The molybdenum content in an aqueously-deposited Cr/Mo alloy is usually quite low--no more than 1 percent. Investigators such as Ma (ref 6) have claimed to have obtained Cr/Mo alloy deposits with molybdenum contents as high as 22 percent. However, attempts by Brenner (ref 5) and Holt (ref 7) to duplicate Ma's results were unsuccessful. More recent attempts to aqueously electrodeposit a direct current (dc)-plated Cr/Mo alloy with molybdenum contents higher than 1 to 2 percent have also been unsuccessful (ref 8). Eckler et al. has successfully raised the molybdenum content in the Cr/Mo alloy above 2 percent through the use of pulse plating (ref 9). The results obtained in Eckler's studies showed that pulse plating can be used to produce crack-free deposits with more than three times the molybdenum content of dc-plated coatings. In addition, Eckler reported that a pulse-plated Cr/Mo alloy deposit had a sixfold increase in wear resistance when compared to conventional chromium deposit and a twofold increase in wear resistance when compared to dc-plated Cr/Mo alloy.

Recognizing the need to improve the erosion and corrosion properties of chromium deposits, as well as the microstructure and mechanical properties of LC chromium, a pulse plating study of LC Cr/Mo alloys was investigated. Unipolar (or on/off) pulse plating, the most conventional form of pulse plating, was used.

EXPERIMENTAL PROCEDURE

The experimental procedure was carried out exactly as described in a previous report (ref 10) except for the electrodeposition process. A standard plating condition consisting of a peak current density of 100 A/dm² and a bath temperature of 85°C was used. The plating bath concentration consisted of the following:

- chromic acid: 250 g/l
- ammonium molybdate: 80 g/l
- sulfuric acid: 2.5 g/l
- trivalent chromium: 4.0 g/l

A schematic diagram showing the pulse plating cell is shown in Figure 1.

In order to use the plated specimens in tensile tests, they were electroformed in the shape of cylinders. A copper tube with a 0.40-cm outer diameter was used as the mandrel (cathode) and masked to a plating area of 5 cm². The cathode was placed vertically in the center of the beaker and rotated at 150 RPM during plating. A cylindrical mesh platinum-coated titanium anode, with a 10.8-cm diameter and 12.7 cm long, was placed inside the beaker. The distance between the cathode and the anode was 5.2 cm. For energy dispersive x-ray analysis (EDAX), specimens were prepared by depositing the pulse-plated LC Cr/Mo alloy on a 2.8 by 2.8 cm copper cathode. The cathode was masked on one side and then positioned and rotated in the same manner as the cylindrical cathode.

A rapid pulse power supply was used to pulse plate the LC Cr/Mo alloy electrodeposits. A rectangular pulsating current, which fluctuated between zero and constant peak cathodic current value, was used. The wave form of the pulsed current was checked with an oscilloscope (Nicolet Model No. 2090). The plating time was adjusted so that the total charge transfer (A-hr/dm²) was kept constant at 240 A-hr/dm².

The on/off pulsing was conducted using low frequency pulse plating (long pulse cycles). On-times of 10, 20, 40, 80, and 100 ms were evaluated for each cycle. The frequency range of the pulsing cycle varied from 5 to 50 Hz, while the duty cycle varied from 9.1 to 91 percent. The frequency and duty cycle corresponding to each on/off condition are shown in Figure 2.

Four specimens were prepared for each of the plating conditions investigated. The current cathode efficiency (CCE), microhardness, and ultimate tensile strength (UTS) are the average of the measurements for the four specimens.

RESULTS AND DISCUSSION

The percent molybdenum in the pulse-plated LC Cr/Mo alloy electrodeposits ranged from approximately 2.4 percent at 5 Hz (100 ms on-time/100 ms off-time) to approximately 1.5 percent at 50 Hz (10 ms on-time/10 ms off-time). The percentages are only approximations due to the limitations of obtaining quantitative measurements with EDAX. Although there was no direct correlation between the plating frequency and the percent molybdenum in the deposits, lower plating frequencies tended to result in higher percentages of molybdenum. The EDAX analysis for the LC Cr/Mo deposits pulsed at 5 Hz and 50 Hz is shown in Figure 3. This trend agrees with Eckler et al. (ref 9) who found that a Cr/Mo alloy electrodeposited at room temperature decreased in molybdenum content from 2 percent to 0.6 percent as the pulsing frequency was increased from 5 to 50 Hz. Power supply limitations prevented investigating lower pulsing frequencies to determine if higher molybdenum contents could have been obtained below 5 Hz.

Although the percent of molybdenum in the pulsed LC Cr/Mo deposits was almost three times greater than the percent obtained through dc plating, the deposits were cracked, somewhat dark in appearance, and insufficiently thin (less than 2 mils). The effects of pulse plating on the hardness and CCE of the LC Cr/Mo electrodeposits are shown in Figure 4. Figure 4a reveals that some of the deposits, particularly all of those plated with an on-time of 10 ms, yielded hardness values greater than 760 KHN--the highest hardness obtained by dc plating LC chromium (ref 10). However, the hardness values showed no improvement over those obtained

when the LC chromium deposits were pulse-plated (ref 11). The pulse-plated LC chromium deposits had hardness values in excess of 1000 KHN.

The maximum hardness values occurred when the on-time was held constant at 10 ms. The one exception was when the off-time was 100 ms. With an off-time of 100 ms, on-times of 10, 20, and 40 ms all yielded hardness values around 900 KHN. The maximum hardness value obtained, 900 KHN, represents an 18 percent increase over the maximum hardness obtained by dc-plating. In general, hardness values for the LC Cr/Mo deposits increased as the on-time decreased and the off-time increased. This same trend was observed with pulse plating LC chromium deposits.

The effects of pulse-plating on the CCE of the LC Cr/Mo electrodeposits are shown in Figure 4b. All CCE values were significantly lower than those obtained through dc or pulse plating LC chromium (refs 10,11). The maximum CCE obtained, 7.3 percent at a on/off condition of 10/100 ms, was 52 percent less than the 15.2 percent CCE obtained when dc plating LC chromium (ref 10).

When the off-time was 40 ms or less, the CCE values were less than 4.3 percent for all on/off conditions tested. This is significantly less than the 12 to 22 percent CCE range obtained when LC chromium was pulse-plated with off-times of 40 ms or less. In general, CCE increased as the off-time increased, with each on-time reaching its maximum CCE at an off-time of 100 ms. This same trend was observed with pulse-plated LC chromium and suggests that lower frequencies and lower duty cycles result in CCE increases. In addition, the 0.5 to 7.3 percent CCE range obtained for these LC Cr/Mo electrodeposits was much lower than the 14 to 27 percent CCE range that Eckler et al. (ref 9) obtained when pulse plating a Cr/Mo alloy. Eckler's deposits were produced at room temperature using a current density of 46.5 A/dm².

Low contraction Cr/Mo electrodeposits produced by pulse plating were of poor quality, poor adhesion, and high stress, and as a result, tensile test measurements were not possible.

The topographical photomicrographs of LC Cr/Mo pulsed deposits are shown in Figure 5. The morphology of the LC Cr/Mo pulsed deposits was some what similar to the morphology of pulse-plated LC chromium (ref 11), but it differed significantly from the morphology of dc-plated LC chromium (ref 10). The topography changed considerably by varying the on/off pulsing conditions. For on/off times of 80/10, 80/20, 100/10, and 100/20 ms, the topography resembled a pattern of interwoven platelets. For on/off times of 20/20, 10/20, and 10/40, the topography resembled a flat cauliflower-like grain surface. However, when the on/off condition was changed to 20/40 and 20/80 ms, the topography resembled a cubic-type structure. Only when the on-time was 40 ms or higher and the off-time was 80 ms or higher, did the topography resemble the hemispherical nodular appearance typical of dc-plated LC chromium (ref 10).

Scanning electron microscope (SEM) photomicrographs showing the cross-sectional microstructure of the pulse-plated LC Cr/Mo electrodeposits are shown in Figure 6. For each of the five on-times tested, the quality of the microstructure tended to increase as the off-time increased. For instance, the microstructure of deposits with off-times of 10 ms tended to be quite porous and cracked, while the microstructure of deposits with off-times of 100 ms was very similar to the typical fibrous grain associated with LC chromium (ref 10).

This trend in the microstructure could explain why the hardness tended to increase as the off-time increased for each on-time tested. In addition, the quality of the microstructure also increased as each on-time was decreased. The microstructure of the LC Cr/Mo deposits pulsed at an on-time of 10 ms more closely resembled the typical fibrous grain associated with LC chromium than the microstructure of deposits pulsed at an on-time of 100 ms. This trend in the microstructure could explain why the hardness of the deposit increased as the on-time decreased.

CONCLUSIONS

The microstructure and mechanical properties of pulse-plated LC Cr/Mo have been evaluated. In addition, comparisons between pulse-plated LC Cr/Mo, pulse-plated LC chromium, and dc-plated LC chromium were made with respect to the microstructure and mechanical properties. Based on the results of our experimental studies, the following conclusions can be made.

1. Pulse plating an LC Cr/Mo alloy at 85°C significantly improved the percent molybdenum in the deposit when compared to dc plating. Molybdenum concentrations as high as 2.4 percent were obtained at the pulsing condition of 100 ms on-time/100 ms off-time. This represents nearly a 300 percent increase over the percent molybdenum obtained in a dc-plated LC Cr/Mo alloy deposit.
2. Lower pulsing frequencies tended to increase the percent molybdenum in the LC Cr/Mo deposit. A pulse frequency of 5 Hz (100 ms on-time/100 ms off-time) resulted in a deposit with 2.4 percent molybdenum.
3. Pulse-plated LC Cr/Mo deposits were generally poor in quality with deposits that were frequently cracked and nodular in appearance. In addition, thicknesses greater than 2 mils could not be obtained at several of the pulsing conditions.
4. Hardness values as high as 900 KHN were obtained for the LC Cr/Mo alloy deposits. This represents an 18 percent increase over the maximum hardness obtained in a dc-plated LC chromium deposit. However, the hardness of the LC Cr/Mo deposits was not as high as the hardness obtained for a pulse-plated LC chromium deposit (1000 KHN).
5. The maximum CCE obtained while plating an LC Cr/Mo alloy deposit was only 7.3 percent. This is nearly 52 percent less than the CCE obtained when dc plating LC chromium.

REFERENCES

1. P. Fenton and A. Oolbekkink, Diesil Engineers and Users Association, June 1973.
2. K. S. Indira and B. Sheno, "Electrodeposition of Chromium-Molybdenum Alloys," *Metal Finishing*, Vol. 63, 1965, pp. 56-79 and pp. 94-97.
3. K. Aotani and K. Nistimoto, *J. Metal Finishing Society of Japan*, Vol. 21, No. 7, 1970, p. 356.
4. F. Bing, X. Fang, G. Wenzhen, Z. Yuan, and L. Yunfeng, "Tribological Characteristics of Cr-Mo Dispersed Electrodeposits," *Proceedings of the JSLE International Tribology Conference*, Tokyo, Japan, 1985.
5. A. Brenner, Electrodeposition of Alloys, Vol II, 1st Ed., Academic Press, Inc., New York, 113, 1963.
6. Chuk Ching Ma (for Westinghouse Electric Corp.), "Electroplating of Chromium-Molybdenum Alloys," U.S. Patent No. 2526227, 1950.
7. M.L. Holt, "Less Common Metals and Alloys, Electrodeposition From Aqueous Solutions," *Metal Finishing*, Vol. 54, 1956, pp. 48-55.
8. Y.V. Pozdeeva, M.A. Shluger, and L.D. Tok, "Effect of Molybdate Ions on Electrodeposition of Chromium," *Prot. Met.*, Vol. 16, No. 3, March-April 1980, pp. 278-280.
9. T. Eckler, B. Manty, and D. McDaniel, *J. Plating and Surface Finishing*, Vol. 67, September 1980, pp. 60-64.
10. S.K. Pan, M.D. Miller, and F.J. Nelson, "Optimization of Plating Parameters for Low Contraction Chromium Electrodeposits," ARCCB-TR-89024, U.S. Army ARDEC, Benét Laboratories, Watervliet, NY, October 1989.
11. M. Miller and S.K. Pan, "The Effects of Pulse Plating On Low Contraction Chromium Electrodeposits," ARCCB-TR-91029, Benét Laboratories, U.S. Army ARDEC, Watervliet, NY, September 1991.

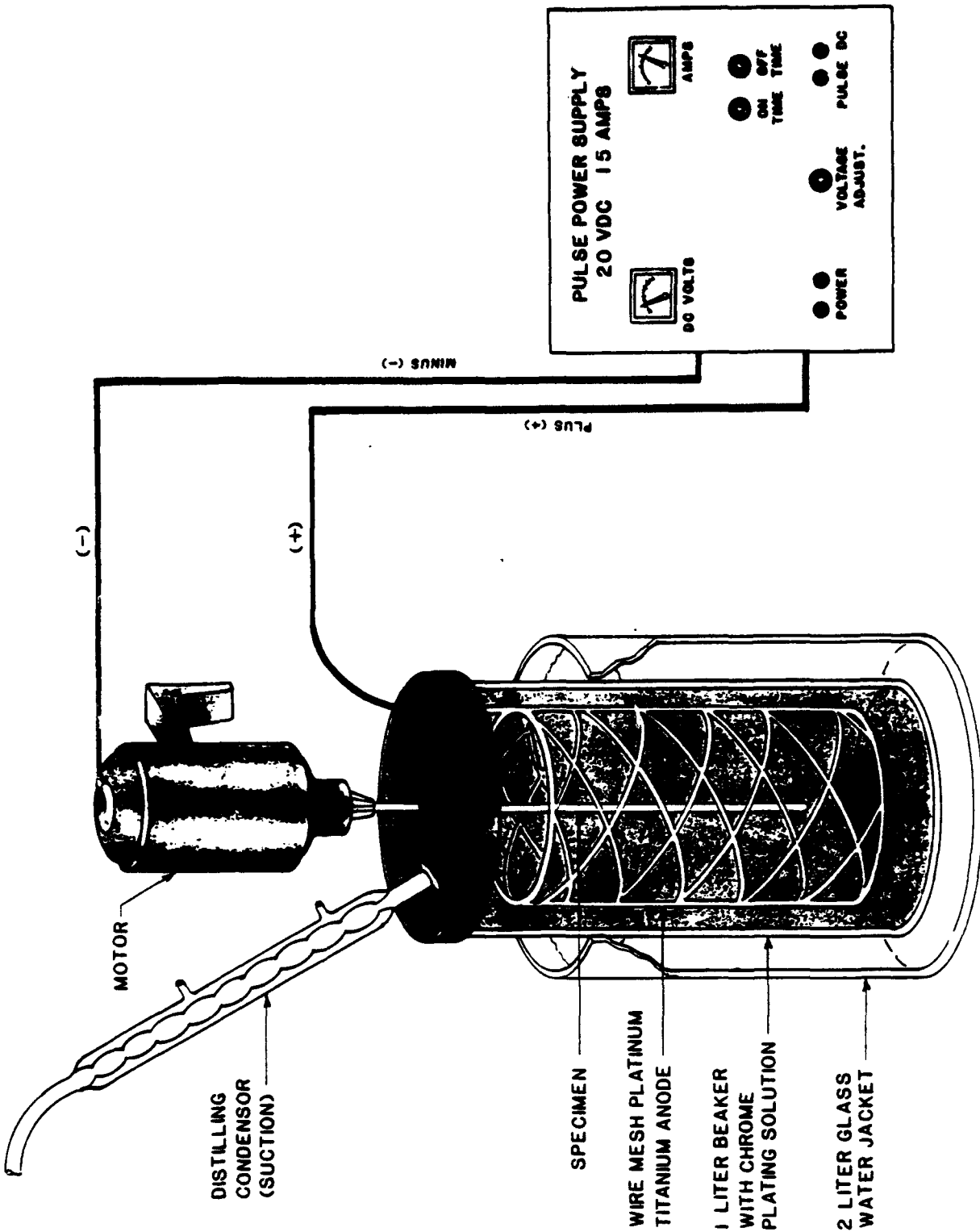

Figure 1. Schematic diagram of the pulse plating cell used to electrodeposit LC Cr/Mo alloy.

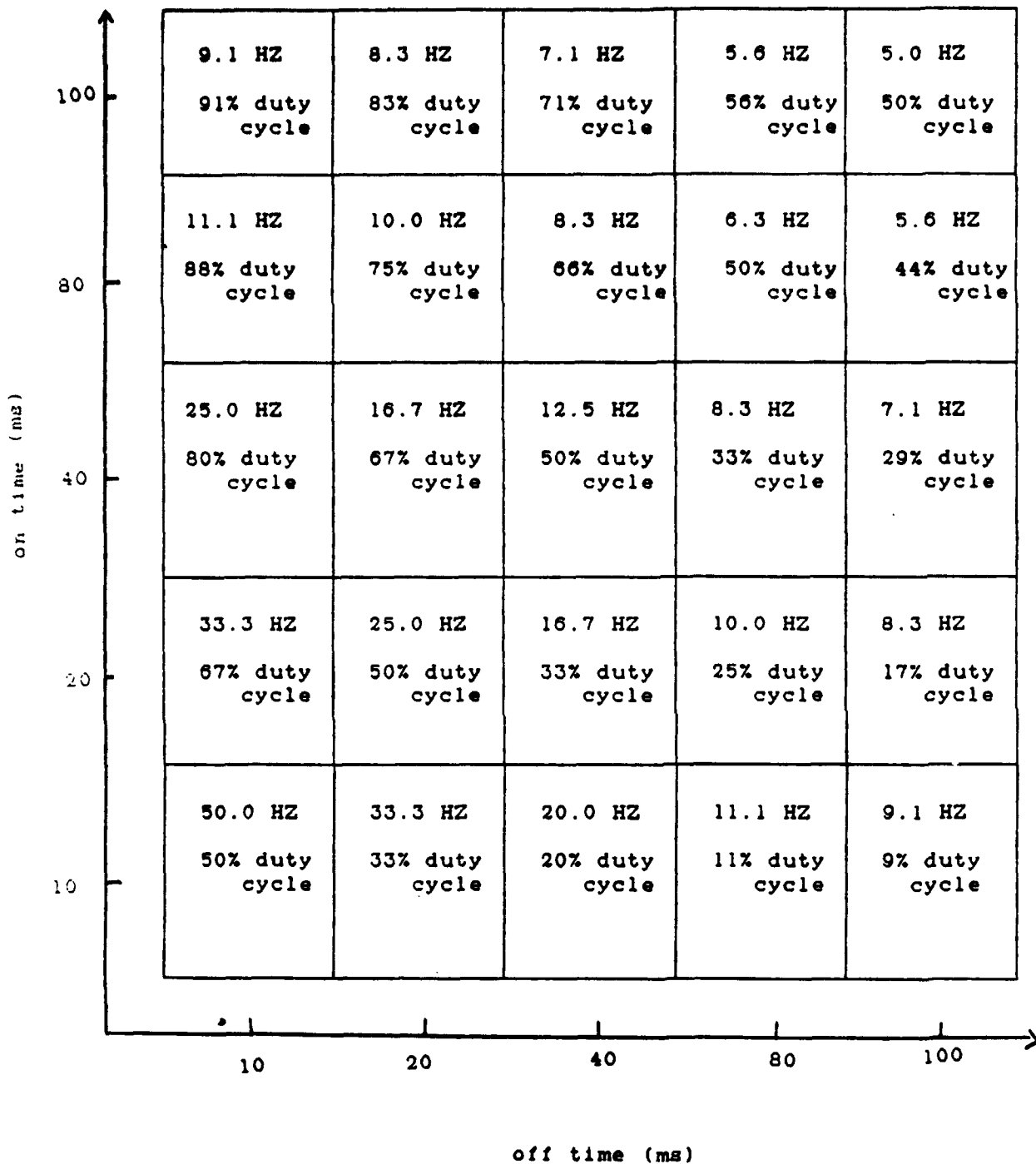

Figure 2. The frequency and duty cycle for each on-time/off-time condition evaluated during the pulse electrodeposition of LC Cr/Mo alloys.

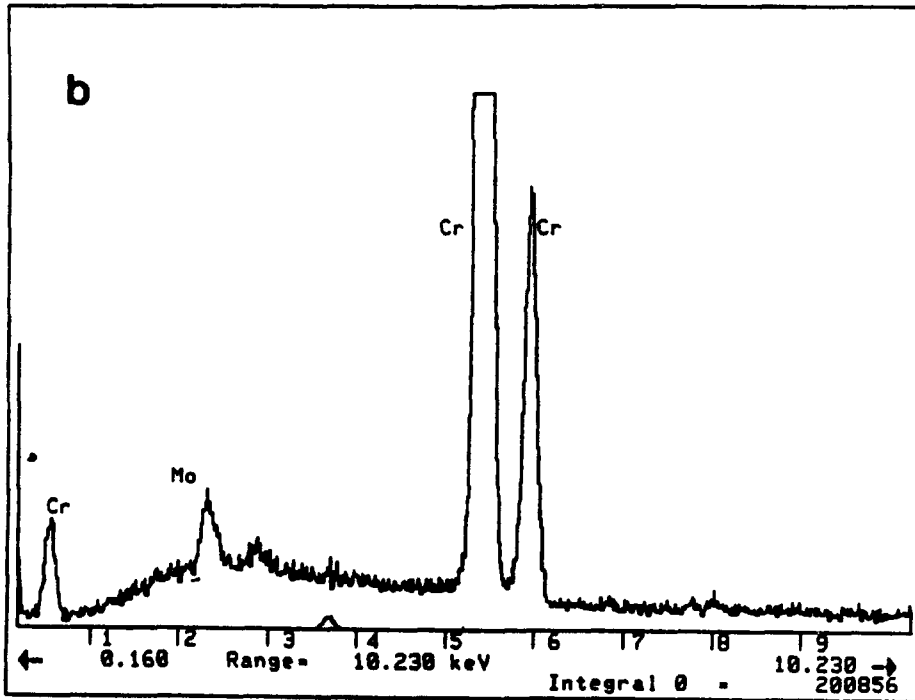
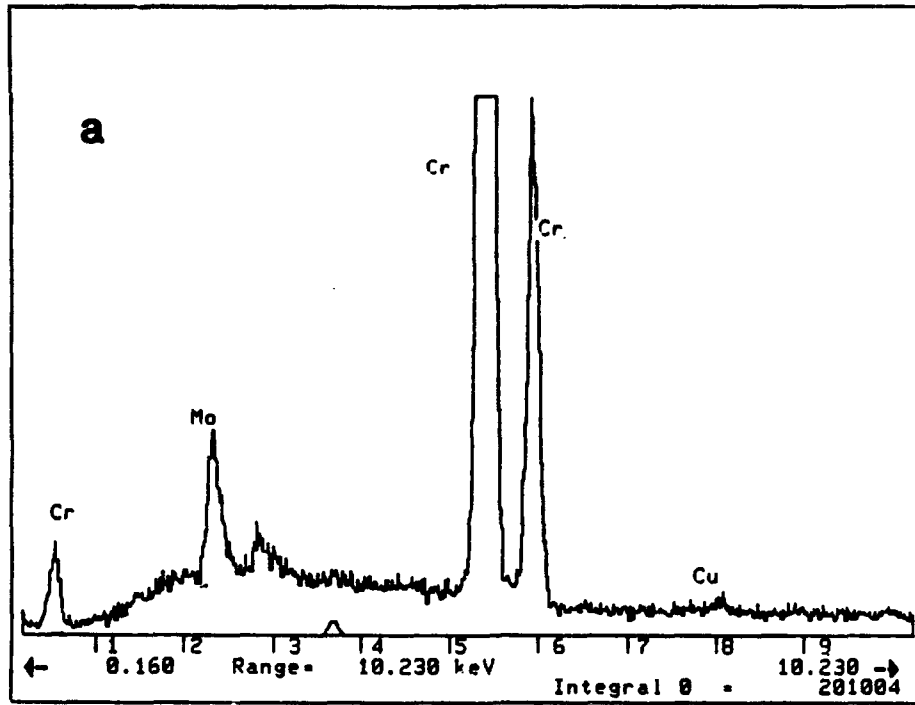

Figure 3. The energy dispersive x-ray analysis (EDAX) of the LC Cr/Mo alloy at (a) 5 Hz (100 ms on/100 ms off) and (b) 50 Hz (10 ms on/10 ms off).

CHROMIUM/MOLYBDENUM ALLOY PLATING STUDY -85°C

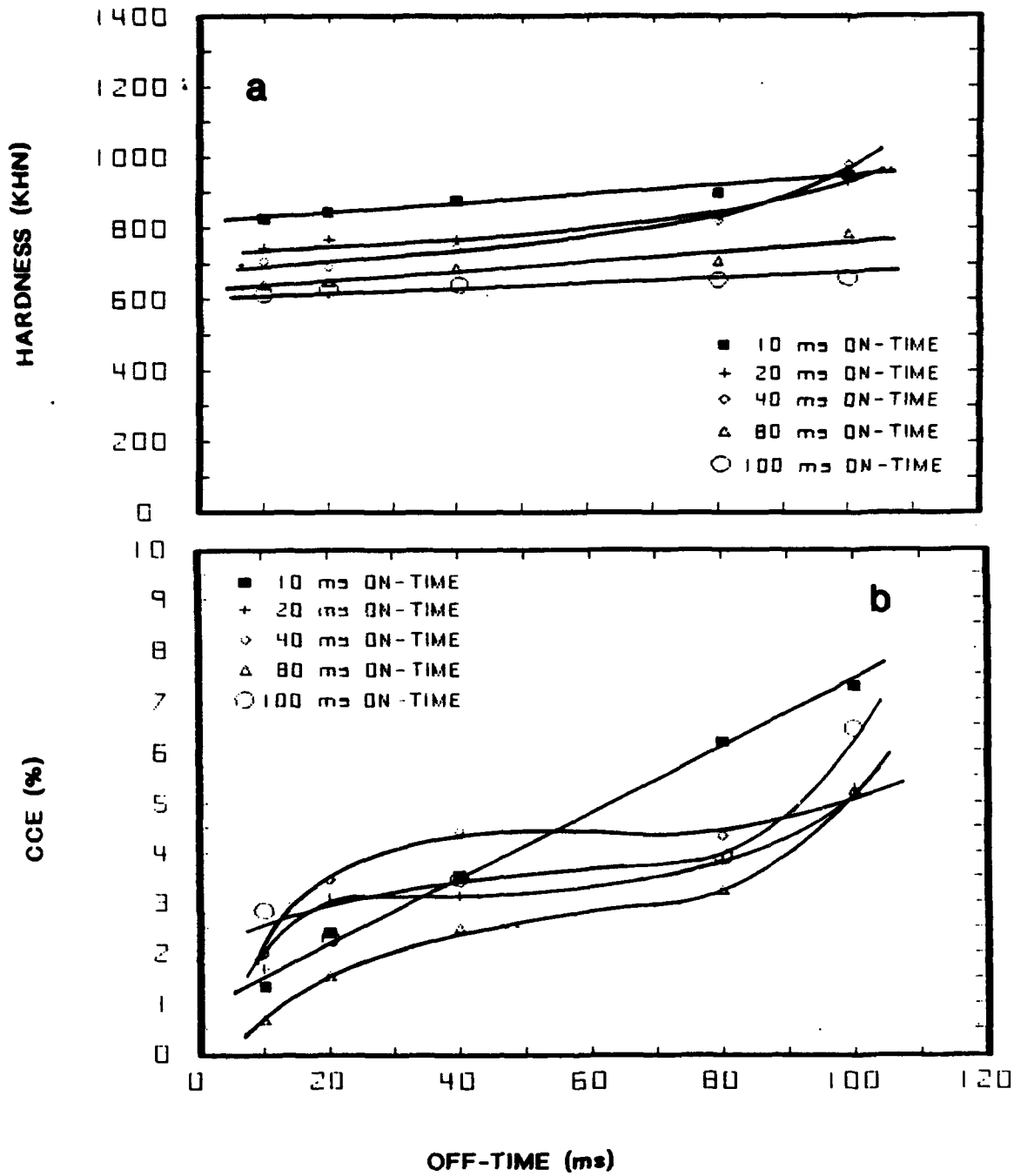

Figure 4. The effects of pulse plating on the (a) hardness and (b) CCE of the LC Cr/Mo electrodeposits.

Cr/Mo ALLOY PULSE PLATING

85°C TOPOGRAPHY

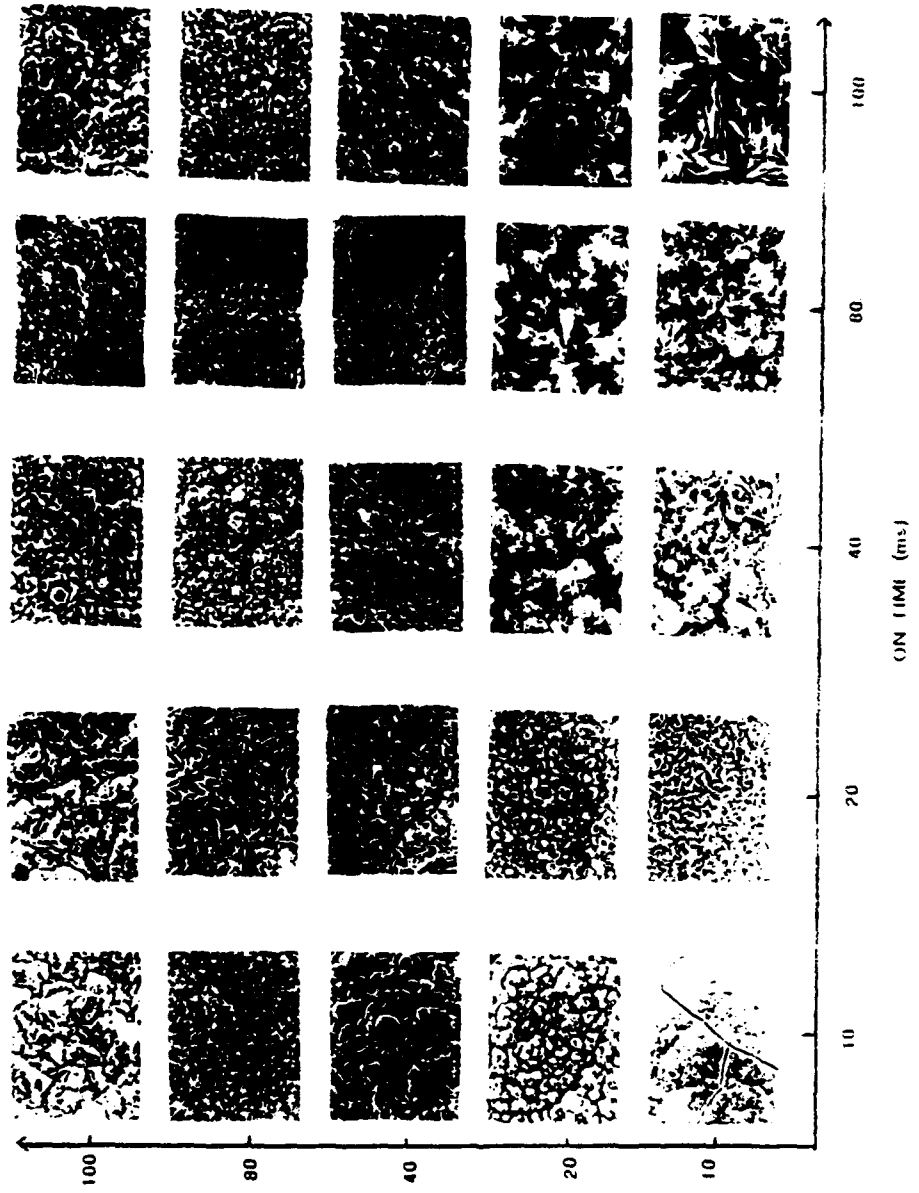

Figure 5. The topographical photomicrographs of pulse-plated LC Cr/Mo electrodeposits.

Cr/Mo ALLOY PULSE PLATING

85°C - MICROSTRUCTURE

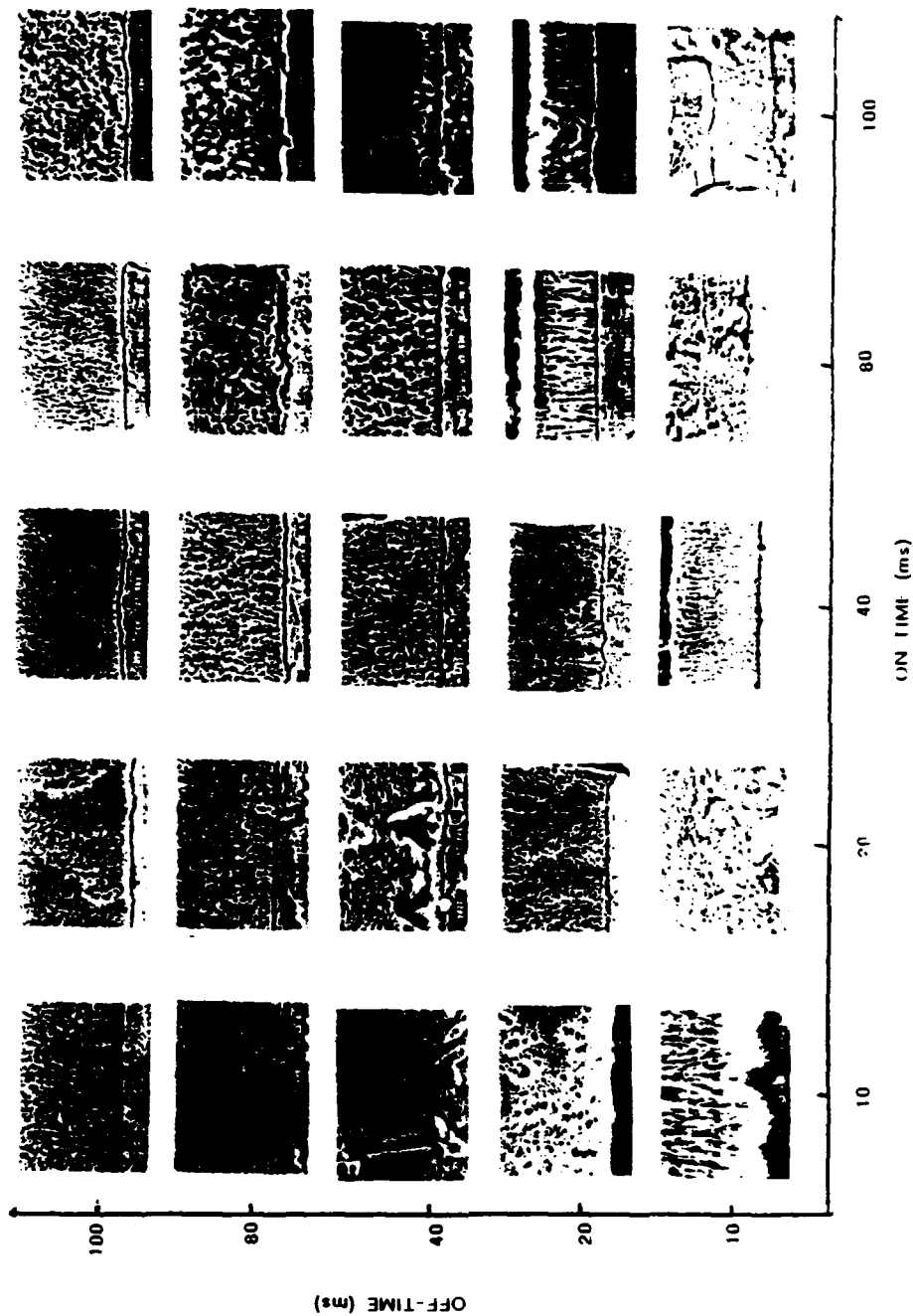

Figure 6. SEM photomicrographs of the cross-sectional microstructure of LC Cr/Mo alloy electrodeposited using pulse plating.

TECHNICAL REPORT INTERNAL DISTRIBUTION LIST

	<u>NO. OF COPIES</u>
CHIEF, DEVELOPMENT ENGINEERING DIVISION	
ATTN: SMCAR-CCB-DA	1
-DC	1
-DI	1
-DR	1
-DS (SYSTEMS)	1
CHIEF, ENGINEERING DIVISION	
ATTN: SMCAR-CCB-S	1
-SD	1
-SE	1
CHIEF, RESEARCH DIVISION	
ATTN: SMCAR-CCB-R	2
-RA	1
-RE	1
-RM	1
-RP	1
-RT	1
TECHNICAL LIBRARY	
ATTN: SMCAR-CCB-TL	5
TECHNICAL PUBLICATIONS & EDITING SECTION	
ATTN: SMCAR-CCB-TL	3
OPERATIONS DIRECTORATE	
ATTN: SMCWV-ODP-P	1
DIRECTOR, PROCUREMENT & CONTRACTING DIRECTORATE	
ATTN: SMCWV-PP	1
DIRECTOR, PRODUCT ASSURANCE & TEST DIRECTORATE	
ATTN: SMCWV-QA	1

NOTE: PLEASE NOTIFY DIRECTOR, BENÉT LABORATORIES, ATTN: SMCAR-CCB-TL OF ADDRESS CHANGES.

TECHNICAL REPORT EXTERNAL DISTRIBUTION LIST

	<u>NO. OF COPIES</u>		<u>NO. OF COPIES</u>
ASST SEC OF THE ARMY RESEARCH AND DEVELOPMENT ATTN: DEPT FOR SCI AND TECH THE PENTAGON WASHINGTON, D.C. 20310-0103	1	COMMANDER ROCK ISLAND ARSENAL ATTN: SMCRI-ENM ROCK ISLAND, IL 61299-5000	1
ADMINISTRATOR DEFENSE TECHNICAL INFO CENTER ATTN: DTIC-FDAC CAMERON STATION ALEXANDRIA, VA 22304-6145	12	MIAC/CINDAS PURDUE UNIVERSITY P.O. BOX 2634 WEST LAFAYETTE, IN 47906	1
COMMANDER U.S. ARMY ARDEC ATTN: SMCAR-AEE	1	COMMANDER U.S. ARMY TANK-AUTMV R&D COMMAND ATTN: AMSTA-DDL (TECH LIBRARY) WARREN, MI 48397-5000	1
SMCAR-AES, BLDG. 321	1	COMMANDER	
SMCAR-AET-O, BLDG. 351N	1	U.S. MILITARY ACADEMY	
SMCAR-CC	1	ATTN: DEPARTMENT OF MECHANICS	1
SMCAR-FSA	1	WEST POINT, NY 10966-1792	
SMCAR-FSM-E	1		
SMCAR-FSS-D, BLDG. 94	1	U.S. ARMY MISSILE COMMAND	
SMCAR-IMI-I, (STINFO) BLDG. 59	2	REDSTONE SCIENTIFIC INFO CENTER	2
PICATINNY ARSENAL, NJ 07806-5000		ATTN: DOCUMENTS SECTION, BLDG. 4484 REDSTONE ARSENAL, AL 35898-5241	
DIRECTOR U.S. ARMY RESEARCH LABORATORY ATTN: AMSRL-DD-T, BLDG. 305 ABERDEEN PROVING GROUND, MD 21005-5066	1	COMMANDER U.S. ARMY FOREIGN SCI & TECH CENTER ATTN: DRXST-SD 220 7TH STREET, N.E. CHARLOTTESVILLE, VA 22901	1
DIRECTOR U.S. ARMY RESEARCH LABORATORY ATTN: AMSRL-WT-PD (DR. B. BURNS) ABERDEEN PROVING GROUND, MD 21005-5066	1	COMMANDER U.S. ARMY LABCOM MATERIALS TECHNOLOGY LABORATORY ATTN: SLCMT-IML (TECH LIBRARY) WATERTOWN, MA 02172-0001	2
DIRECTOR U.S. MATERIEL SYSTEMS ANALYSIS ACTV ATTN: AMXSY-MP ABERDEEN PROVING GROUND, MD 21005-5071	1	COMMANDER U.S. ARMY LABCOM, ISA ATTN: SLCIS-IM-TL 2800 POWER MILL ROAD ADELPHI, MD 20783-1145	1

NOTE: PLEASE NOTIFY COMMANDER, ARMAMENT RESEARCH, DEVELOPMENT, AND ENGINEERING CENTER, U.S. ARMY AMCCOM, ATTN: BENÉT LABORATORIES, SMCAR-CCB-TL, WATERVLIET, NY 12189-4050 OF ADDRESS CHANGES.

TECHNICAL REPORT EXTERNAL DISTRIBUTION LIST (CONT'D)

	<u>NO. OF COPIES</u>		<u>NO. OF COPIES</u>
COMMANDER U.S. ARMY RESEARCH OFFICE ATTN: CHIEF, IPO P.O. BOX 12211 RESEARCH TRIANGLE PARK, NC 27709-2211	1	COMMANDER AIR FORCE ARMAMENT LABORATORY ATTN: AFATL/MN EGLIN AFB, FL 32542-5434	1
DIRECTOR U.S. NAVAL RESEARCH LABORATORY ATTN: MATERIALS SCI & TECH DIV CODE 26-27 (DOC LIBRARY) WASHINGTON, D.C. 20375	1 1	COMMANDER AIR FORCE ARMAMENT LABORATORY ATTN: AFATL/MNF EGLIN AFB, FL 32542-5434	1

NOTE: PLEASE NOTIFY COMMANDER, ARMAMENT RESEARCH, DEVELOPMENT, AND ENGINEERING CENTER, U.S. ARMY AMCCOM, ATTN: BENÉT LABORATORIES, SMCAR-CCB-TL, WATERVLIET, NY 12189-4050 OF ADDRESS CHANGES.
