

①

**DREDGING RESEARCH PROGRAM**

CONTRACT REPORT DRP-94-2

**ACOUSTIC RESUSPENSION MEASUREMENT  
SYSTEM (ARMS) INSTRUMENTATION MANUAL**

by

Robert E. Van Evra III, Keith W. Bedford

Ohio State University  
2070 Neil Avenue  
Columbus, Ohio 43210

**AD-A282 901**

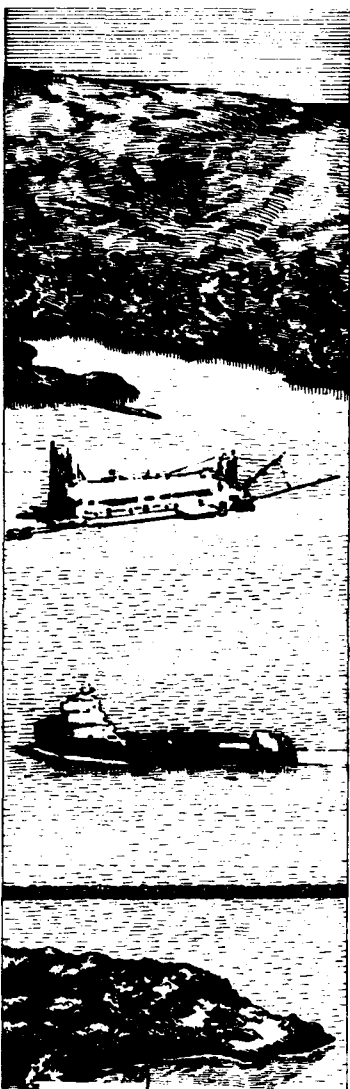
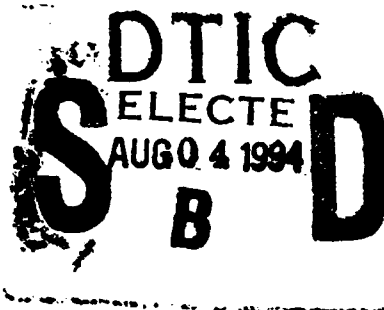

03 037

June 1994

Final Report

Approved For Public Release; Distribution Is Unlimited

Prepared for DEPARTMENT OF THE ARMY  
U.S. Army Corps of Engineers  
Washington, DC 20314-1000

Monitored by U.S. Army Corps of Engineers  
Waterways Experiment Station  
3909 Halls Ferry Road, Vicksburg, Mississippi 39180-6199

Under Work Unit No. 32464



US Army Corps  
of Engineers

1322g

**94-24514**



**The Dredging Research Program (DRP) is a seven-year program of the US Army Corps of Engineers. DRP research is managed in these five technical areas:**

- Area 1 - Analysis of Dredged Material Placed in Open Water**
- Area 2 - Material Properties Related to Navigation and Dredging**
- Area 3 - Dredge Plant Equipment and Systems Processes**
- Area 4 - Vessel Positioning, Survey Controls, and Dredge Monitoring Systems**
- Area 5 - Management of Dredging Projects**

**Destroy this report when no longer needed. Do not return it to the originator.**

**The contents of this report are not to be used for advertising, publication, or promotional purposes. Citation of trade names does not constitute an official endorsement or approval of the use of such commercial products.**



US Army Corps  
of Engineers  
Waterways Experiment  
Station

# Dredging Research Program Report Summary



## ***Acoustic Resuspension Measurement System (ARMS) Instrumentation Manual (CR DRP-94-2)***

**ISSUE:** Accurate field data are needed to characterize fluid motion and sediment-transport properties of proposed dredged material placement sites for site designation and for later site monitoring. Such data are also required to verify environmental numerical simulation models.

**RESEARCH:** Advances in the field of high-frequency acoustics have made available an assortment of instruments using sound frequencies that allow direct observations of fluid and sediment motion within 0.1 cm/sec. Parallel advances in high-speed, low-power integrated electronics enabled the contractor to combine these instruments and their controlling circuitry in compact battery-powered packages. These instrument packages (ARMS) were contained in relatively small pressure housings and mounted on an unobtrusive bottom-standing tripod. ARMS was tested in open water as part of a dredging project and proved to be highly accurate and reliable. The ARMS system is available for turn-key use by Corps field offices.

**SUMMARY:** The Instrumentation Manual includes: descriptions of the sensors and the tripod platform; ARMS control and signal-conditioning circuitry; and power control, hardware, storage, and battery considerations. The appendices contain comprehensive physical and schematic diagrams, timing schemes, and the software codes.

**NOTE:** Deployment techniques for ARMS were described in the *Dredging Research Technical Note DRP-1-05*, "Acoustic Resuspension Measurement System," April 1992.

**AVAILABILITY OF REPORT:** The report is available through the Interlibrary Loan Service from the U.S. Army Engineer Waterways Experiment Station (WES) Library, telephone number (601) 634-2355. National Technical Information Service (NTIS) report numbers may be requested from WES Librarians.

To purchase a copy of the report, call NTIS at (703) 487-4780.

**About the Authors:** Both authors are on the staff of the Department of Civil Engineering, Ohio State University: Robert E. Van Evra III, Senior Research Scientist, and Dr. Keith W. Bedford, Professor.

**Point of Contact:** E. Clark McNair, Jr., WES, who is the Manager of the Dredging Research Program, at (601) 634-2070.

# **Acoustic Resuspension Measurement System (ARMS) Instrumentation Manual**

by **Robert E. Van Evra III, Keith W. Bedford**

**Ohio State University  
2070 Neil Avenue  
Columbus, OH 43210**

**Final report**

*Approved for public release; distribution is unlimited*

<b>Accession For</b>	
<b>NTIS GRA&amp;I</b>	<input checked="" type="checkbox"/>
<b>DTIC TAB</b>	<input type="checkbox"/>
<b>Unannounced</b>	<input type="checkbox"/>
<b>Justification</b>	
<b>By</b>	
<b>Distribution/</b>	
<b>Availability Codes</b>	
<b>Dist</b>	<b>Avail and/or Special</b>
<i>1</i>	

**Prepared for U.S. Army Corps of Engineers  
Washington, DC 20314-1000**

**Monitored by U.S. Army Engineer Waterways Experiment Station  
3909 Halls Ferry Road, Vicksburg, MS 39180-6199**

**Under Work Unit 32464**



**US Army Corps  
of Engineers**  
Waterways Experiment  
Station

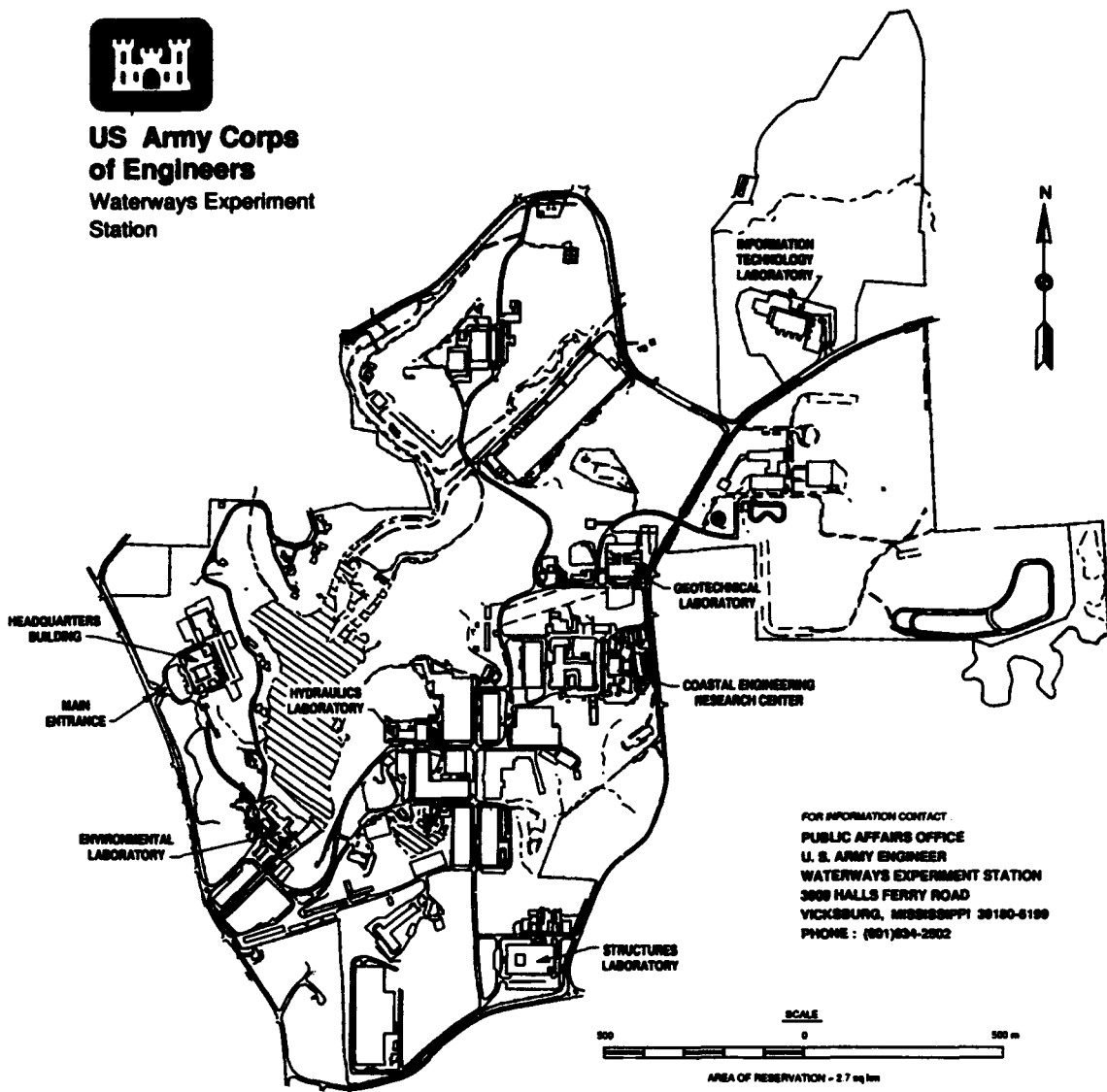

**Waterways Experiment Station Cataloging-in-Publication Data**

Van Evra, Robert E.

Acoustic Resuspension Measurement System (ARMS) instrumentation manual by Robert E. Van Evra, Keith W. Bedford ; prepared for U.S. Army Corps of Engineers ; monitored by U.S. Army Engineer Waterways Experiment Station.

130 p. : ill. ; 28 cm. — (Contract report ; DRP-94-2)

1. Suspended sediments — Environmental aspects. 2. Dredging spoil — Environmental aspects. 3. Boundary layer — Data processing. 4. Sedimentation and deposition — Measurement — Instruments. I. Bedford, Keith W. II. United States. Army. Corps of Engineers. III. U.S. Army Engineer Waterways Experiment Station. IV. Dredging Research Program. V. Title. VI. Series: Contract report (U.S. Army Engineer Waterways Experiment Station) ; DRP-94-2. TA7 W34c no.DRP-94-2

# Contents

---

Preface .....	ix
Conversion Factors, Non-SI to SI Units of Measurement .....	x
1—Introduction .....	1
The Dredging Research Program .....	1
Goals of Technical Area 1 .....	1
Report Goals and Content .....	2
2—Instrument Requirements .....	3
Overview .....	3
Necessary Boundary Layer Measurements .....	4
Desired Associated Measurements .....	6
3—ARMS Instrumentation .....	8
Acoustic Concentration Profiler .....	8
Acoustic Velocimeter .....	14
Pressure Sensor .....	18
4—Ancillary Instrumentation .....	22
Inclinometer .....	22
Compass .....	23
Thermistor .....	26
Optical Backscatter Sensor .....	26
High-Frequency Acoustic Non-Destructive Sediment Sizer .....	28
5—Field Configuration .....	30
Design Considerations .....	30
ARMS Tripod .....	32
6—ARMS Control System .....	35
Overview .....	35
Requirements .....	35
Microcontroller .....	36
Programmable Logic Device .....	38
Analog/Digital Conversion .....	44
Controller Board .....	47
7—Signal Conditioning .....	49

Requirements .....	49
Specialized Profilometer Circuitry .....	50
Other Conditioning Circuits .....	53
Signal Conditioning Board .....	55
8—Power Control .....	56
Overview .....	56
Switching Schemes .....	57
Power Control Board .....	58
9—ARMS Hardware Chassis .....	60
Pressure Container .....	60
BASS Chassis .....	60
ARMS Chassis .....	62
Internal Connectors .....	62
External Connectors .....	62
10—Mass Storage Unit .....	64
Streaming Tape Drive .....	64
Isolated Battery Supply .....	66
Pressure Housing .....	66
11—Battery Pack .....	67
Power Requirements .....	67
Battery Options .....	67
References .....	69
Appendix A: Physical Diagrams .....	A1
Appendix B: Schematic Diagrams .....	B1
Appendix C: Circuit Signals and Timing Diagrams .....	C1
Appendix D: Software .....	D1
SF 298	

## List of Figures

---

Figure 1. ACP conceptual diagram .....	9
Figure 2. ACP electronic characteristics .....	12
Figure 3. BASS cage .....	15
Figure 4. Tattletale V .....	16
Figure 5. BASS and ARMS chassis in place .....	16
Figure 6. BASS vector representation .....	18
Figure 7. Wika ST-420 pressure transducer .....	21

Figure 8.	Lucas Accustar II dual-axis inclinometer	23
Figure 9.	Aanderaa Model 1248 potentiometric compass	25
Figure 10.	YSI #44018 thermistor composite	26
Figure 11.	OBS	28
Figure 12.	HANDSS	29
Figure 13.	BASS-ACP positioning	31
Figure 14.	ARMS tripod	33
Figure 15.	HPC 16000 microcontroller block diagram	37
Figure 16.	PLD block diagram	40
Figure 17.	Max 158 block diagram	45
Figure 18.	MAX 158 reference circuit	45
Figure 19.	ADC timing diagram	46
Figure 20.	Controller board layout	48
Figure 21.	Switched integrator block diagram	51
Figure 22.	Integrator mode of operation	52
Figure 23.	DAC block diagram	53
Figure 24.	Unity gain amplifier circuit	54
Figure 25.	Thermistor conversion circuit	54
Figure 26.	Signal conditioning board layout	55
Figure 27.	Distributed power diagram	57
Figure 28.	Power board layout	59
Figure 29.	BASS end caps	61

## List of Tables

---

Table 1.	ACP Transducer Data	12
Table 2.	ACP Electronics Specifications	13
Table 3.	Wika ST-420 Pressure Transducer Specifications	19
Table 4.	Pressure Transducer Ranges Available	20
Table 5.	Inclinometer Environmental Specifications	23
Table 6.	Inclinometer Electrical Specifications	24
Table 7.	Inclinometer Performance Specifications	24
Table 8.	Compass Specifications	25

<b>Table 9.</b>	<b>YSI Thermistor Specifications</b>	<b>27</b>
<b>Table 10.</b>	<b>HPC Features</b>	<b>38</b>
<b>Table 11.</b>	<b>PLD Features</b>	<b>41</b>
<b>Table 12.</b>	<b>PAD Configurations</b>	<b>42</b>
<b>Table 13.</b>	<b>16000/301 Memory Map</b>	<b>43</b>
<b>Table 14.</b>	<b>MAX 158 Channel Codes</b>	<b>45</b>
<b>Table 15.</b>	<b>Streaming Tape Drive Specifications</b>	<b>65</b>

# Preface

---

This study was conducted at the Department of Civil Engineering, the Ohio State University (OSUCE), under contract with the Coastal Engineering Research Center (CERC), U.S. Army Engineer Waterways Experiment Station (WES). The work described herein was authorized as part of the Dredging Research Program (DRP) of the U.S. Army Corps of Engineers (USACE) and was performed under Work Unit 32464, "Measurement of Entrainment and Transport (Noncohesive Sediments)." Messrs. Glenn R. Drummond, Rixie J. Hardy, Vincent Montante, and John J. Perez were DRP Technical Monitors from Headquarters, USACE. Mr. E. Clark McNair, Jr., CERC, is Program Manager (PM) for the DRP, and Dr. Lyndell Z. Hales (CERC) is Assistant PM.

This study was performed and the report prepared over the period 1 December 1991 through 28 February 1992 by Robert E. Van Evra III, Senior Research Scientist, OSUCE, under the supervision of Dr. Keith W. Bedford, Professor, OSUCE. Assisting in preparation of the report were Messrs. Sean O'Neil, Sumarto Sulistio, and Jongkook Lee, Graduate Research Associates, OSUCE. Dr. Nicholas C. Kraus, Senior Scientist, Research Division (RD), CERC, was the Principal Investigator of Work Unit 32464 and provided review of the report. Work was conducted under the general supervision of Dr. James R. Houston, Director, CERC; Mr. Charles C. Calhoun, Jr., Assistant Director, CERC; and Mr. H. Lee Butler, Chief, RD, CERC. Ms. Michelle M. Thevenot, CERC, edited the draft report submitted from OSUCE.

At the time of publication of this report, Director of WES was Dr. Robert W. Whalin. Commander was COL Bruce K. Howard, EN.

Additional information can be obtained from Mr. E. Clark McNair, Jr., DRP Program Manager, at (601) 634-2070.

# Conversion Factors, Non-SI to SI Units of Measurement

---

Non-SI units of measurement used in this report can be converted to SI units as follows:

Multiply	By	To Obtain
degrees (angle)	0.01745329	radians
Fahrenheit degrees	5/9	Celsius degrees or kelvins*
feet	0.3048	meters
inches	2.54	centimeters
ounces (mass)	28.34952	grams
pounds (force) per square inch	6.894757	kilopascals
pounds (mass)	0.4535924	kilograms

\* To obtain Celsius (C) temperature readings from Fahrenheit (F) readings, use the following formula:  $C = (5/9) (F - 32)$ . To obtain kelvin (K) readings, use:  $K = (5/9) (F - 32) + 273.15$ .

# 1 Introduction

---

## The Dredging Research Program

The Dredging Research Program (DRP) is a major research and development program initiated by the Corps of Engineers to address problems arising in the performance of the Corps' dredging mission and to develop improved technologies to reduce the costs of dredging operations (U.S. Army Corps of Engineers 1988). The program focuses on five problem areas. Technical areas 1 and 2 deal with analysis of open-water disposed dredged material and material properties related to navigational dredging, respectively. Technical areas 3, 4, and 5 address dredging equipment and processes, monitoring vessel positioning, and management of dredging projects, respectively. This study is a part of DRP Technical Area 1.

## Goals of Technical Area 1

Technical Area 1 of the DRP is designated Analysis of Dredged Material in Open Waters. The following is a list of its goals:

- a.* Better calculation of boundary layer properties for analyzing behavior of open-water disposal areas.
- b.* Acquisition of field data sets for use in improving the calculation of boundary layer properties.
- c.* Improvement of computational techniques to predict the short-and long-term fate of dredged material.
- d.* Collection of data for input to improved simulation methods and development of improved site-monitoring techniques.

In partial fulfillment of these goals, the Acoustic Resuspension Measurement System (ARMS) has been designed and constructed. The ARMS employs a suite of ultrasonic and other instruments to observe near-bottom sediment resuspension and transport driven by waves and currents at open-water disposal sites. Using a sophisticated custom-designed electronics package, ARMS processes and collects the field data necessary to improve the

understanding of boundary layer properties and development methods for simulating and monitoring in situ benthic boundary layer (BBL) processes. The entire self-contained ensemble is mounted on a rapidly deployable tripod for ease of use under the wide variety of field conditions and available support experienced in dredging operations.

## **Report Goals and Content**

This report provides a description of the various BBL measurement requirements, as well as a detailed description of the instrumentation and electronics of the ARMS package. (Deployment techniques for ARMS were described in *Dredging Research Technical Note DRP-1-05*, "Acoustic Resuspension Measurement System," April 1992.) Chapters 1 and 2 address the objectives of the DRP and the requirements of the instrumentation used to meet these goals. The individual ARMS sensors and their tripod platform are presented in Chapters 3, 4, and 5. Chapters 6 and 7 describe the ARMS control and signal conditioning circuitry, and Chapters 8-11 deal with the power control, hardware, storage, and battery considerations, respectively.

Appendix A is a comprehensive set of physical diagrams, Appendix B is made up of schematic diagrams, timing schemes are provided in Appendix C, and the software code is provided in Appendix D.

## 2 Instrument Requirements

---

### Overview

In order to investigate bottom boundary layer conditions thoroughly, an instrument array must be able to observe all of the related parameters very closely. Unfortunately, the scale of some of the phenomena involved is so small that the physical intrusion of any solid probe into the measured volume will alter the local hydrodynamic conditions. This is enough to invalidate an assumption that the probe is measuring undisturbed, naturally occurring conditions.

There are parameters that can be measured with probes. Some measure background conditions that do not vary appreciably within the study area. Other probes can be deployed remotely enough, yet yield quantifiable representations of the ambient conditions on the bottom. Probes pass a crucial test of utility if they do not impede the parameter that they are being used to measure.

One method of observing a remote area of seafloor is with the use of light. Optical instruments have been used for years to characterize some of the parameters associated with boundary layer activity. However, most of these make measurements within close proximity of the instrument itself, not allowing the local flow field to remain unaltered. Using light to measure values farther away from the instrument is sometimes possible, but the amount of suspended sediment in the water column during strong turbulent episodes is usually high enough to prevent light from penetrating far enough to consistently reach all points being studied.

Using sound to gather information about underwater conditions is a more effective process. Sound can travel much farther through water than light before it is significantly absorbed/dissipated, depending on the frequency used. Sound is also reflected by suspended sediment particles. The advantage of sound, however, is that its slower velocity makes it possible to determine the position of objects relative to the source/receiver, by measuring the two-way travel time. Sonar has been in use for over 50 years, originally by the Navy for use in determining range between vessels. More recently, advances in electronics and transducer technology have allowed the evolution of sonar into various active and passive applications that yield even more information through digital processing of the acoustic signals.

The same properties that make sound useful in large-scale applications like sonar have inspired the development of electronics and transducers that utilize the small-scale behavior of high frequencies. These high frequencies are greatly attenuated by water and are not useful over long distances, but over short ranges they may yield extremely detailed information about minute variations in certain variables, such as suspended sediment and water velocities. These characteristics are the key to the development and use of instruments that can measure the micro-scale interactions of water and sediment occurring at the bottom boundary layer without physically being close enough to interfere with ambient conditions.

## **Necessary Boundary Layer Measurements**

In this section the background requirements of an instrument array used to measure entrainment are discussed.

### **Suspended sediment**

In field conditions, depending on the amount of energy being imparted to the area from wind, waves, and currents, there is a varying amount of sediment that is being resuspended into the water column off the seafloor. The manner in which this occurs determines the physical transport of bottom material at the site. Attempts to characterize the mechanisms of this process will benefit greatly from the quantification of the dimensional and temporal orientation of the particles themselves, since the sediments are the focus of concern for dredging researchers. The best possible scenario for an instrument solution is a device that can measure multiple characteristics of the suspended sediment simultaneously.

To observe the time history accurately, the instrument must sample rapidly enough to capture all of the small and complex motions occurring. The Nyquist frequency of the required sampling to statistically identify temporal variations is twice that of the varying parameter itself. Since sediment concentrations in the bottom boundary layer may vary on the order of seconds (Bedford and Abdelrhman, 1987), a device must sample on the order of 1-5 Hz, depending on the temporal resolution desired.

The spatial distribution of suspended sediment is critical to its availability for movement both vertically and horizontally. The small-scale structure occurring right at the bottom is especially important to what happens to the sediment higher in the water column. To see the fine structures in both cases, a remote instrument must be able to measure variations within a centimeter (Bedford and Abdelrhman, 1987). Again, high-frequency sound has wavelengths small enough to effectively sample and differentiate in this scale.

Sediment properties other than motion are also important. The amount of sediment at each of these locations at every sampling interval is basic to

understanding the total mass transport occurring at a BBL site. Important hydrodynamic information can be obtained from the grain size distribution of sediment particles, their mobility, settling velocity, and other associated attributes such as surface reflectivity and composition.

### **Velocities**

The motion of the sediment particles into the water column may also be investigated by observing the motion of the water that suspends them. Knowing the motion of the water mass above a studied area of bottom sediment is fundamental to representing the hydrodynamics at work even during the shortest period of time, down to the slightest movement. In order to record motions, velocity readings must be both highly accurate, with resolutions down to tenths of a centimeter per second, and taken rapidly in time to capture subtle, yet important, variations over small scales. Again, sampling rates in the 1- to 5-Hz range are needed to observe the time scale of variations occurring in most boundary layer environments.

The importance of three-dimensional measurements cannot be overemphasized, since motion in any direction in a fluid medium is possible. Also, the availability of velocity readings from more than one point will assist in reconstructing overall larger-scale patterns occurring at the site. Since a solid probe cannot be placed in a flow field without causing a disturbance in the motion of water and particles, and since accounting for the disturbance in the data generated would be difficult, a remote method for measuring velocities is ideal.

### **Pressure**

The motions of the water mass are ultimately driven by larger forces at the site, such as waves and currents. While velocity instrumentation operated at 1- to 5-Hz sampling rates with resolutions down to tenths of a centimeter per second will have no trouble discerning any larger-scale current activity in the area, it is difficult to use wave-induced velocity variations at the bottom by themselves to back-calculate and infer surface wave conditions.

A hydraulic pressure reading taken in a geometrically significant position with relation to simultaneous velocity readings will help in resolving at least crest-to-trough pressure variations and, if sampled as frequently as the velocity, should help in differentiating wavelengths (and even possibly the shape of each wave). A fast-response sensor that can differentiate 1-2 cm of water pressure would be adequate. With even less resolution, as long as it is sampled in a 1- to 5-Hz range, pressure readings will enhance other data as well as yield their own important information.

## **Temperature**

Temperature variation can be used to determine many characteristics of the study site. For example, it can help discern transient coherent packets of water or the effects of day and night variations at the site. Fortunately, due to the high thermal conductivity of water, temperature does not tend to vary on the extremely small temporal and spatial scales that sediment concentration and velocity do, so it is not necessary to insert a temperature probe into the middle of a flow field to infer the local temperature. Taken in the area, however, a temperature record will help determine local hydrostatic conditions such as density and speed of sound.

## **Desired Associated Measurements**

This section provides a description of other parameters related to the water column activity at a field site that will be useful (but not required) in assisting interpretation of the hydrodynamic environment there.

### **Bottom topography**

To keep an instrument array operating in a pertinent manner, it is desirable to obtain as much information about the peripheral environment around the study area. Knowledge of the local bottom topography will initially help determine the suitability of an area for study, especially if the goal is to find a site with a flat, uniform bottom where data acquired would be uncomplicated by obstructed flow patterns. If the site is in an area of irregular bottom topography, having bathymetric information from the area will be very helpful in assisting the processing of all boundary layer data obtained.

The very important relationship to be established is the position of the instrument array with respect to the local bottom topography. This information is fundamental to the proper interpretation of observations by the other instrumentation at the field site. Over small scales, the exact bottom slope is a direct input into the boundary layer solutions of hydrodynamic activity. The slope, as well as its compass orientation, will assist in verifying the exact attitude of the instruments relative to the physical layout of the study site.

### **Bottom conditions**

In understanding the resuspension being observed by field instrumentation, it is helpful to know the physical nature of the bottom. As mentioned before, grain size data are very important to understanding the sediment, but they can also be helpful in quantifying how thoroughly the sediments are compressed or if there is any nonhomogeneity in the vertical cross section. This, as well as information about any bottom features such as ripples, can help establish the

bottom's erodibility, which makes all of the hydrodynamic data collected ultimately more valuable.

### **Large-scale hydrodynamics**

The velocity information taken at the site will yield data revealing magnitudes and directions of the predominant currents. It is desirable to associate these readings with larger-scale activity. Tidal cycles, offshore eddies, and internal waves can all influence the local velocity distribution through the water column. Although the field instruments may collect data that infer their effects, any supplemental information concerning these larger-scale phenomena will help determine their significance to boundary layer occurrences.

### **Surface activity**

Although pressure and velocity instrumentation yield the necessary data concerning the boundary layer effects of surface waves and their magnitude and periodicity, any available corroborating information about the speed, direction, period, and height of each set of surface waves will assist in the reduction of the field data. Observations of local wind speed and direction and associated air temperature and barometric pressure will also be of possible value in understanding shear stress effects at the sea surface.

## **3 ARMS Instrumentation**

---

### **Acoustic Concentration Profiler**

To obtain high speed/high resolution numerical data on the vertical suspended sediment concentration profile, a device called the acoustic concentration profiler (ACP), or profilometer, has been developed by the Coastal Engineering Laboratory at the Ohio State University. This device was originally designed as the Model 563 high-resolution depth sounder by the Edo Corporation, Western Division, of Salt Lake City, UT (Edo Corporation 1981). The version used in the ARMS system has been modified to improve performance in the near field of the transducer. By using a special diamond-shaped transducer, the manufacturers were able to significantly reduce its side lobes while also narrowing the main beam. This makes the instrument both very responsive and able to insonify a small enough cross section of the water column to allow range-gated reflectivity measurements over volumetric bins of statistically suitable size for the study of hydrodynamic motion of entrained sediment.

In the range of the 3-MHz sound source, the resulting acoustic reflections off individual suspended sediment particles are strong enough to be detected by the transducer (Figure 1). By rapidly switching the transducer over to an electronic receiver circuit after it has transmitted an acoustic pulse, the instrument becomes an extremely sensitive hydrophone, picking up and amplifying the series of reflected signals from locations along the profile. The received signals are amplified, processed, and stored by the ARMS circuitry to later be converted into actual concentration profile data. The following statistical and acoustic considerations of the data conversion process are covered completely in Libicki, Bedford, and Lynch (1989).

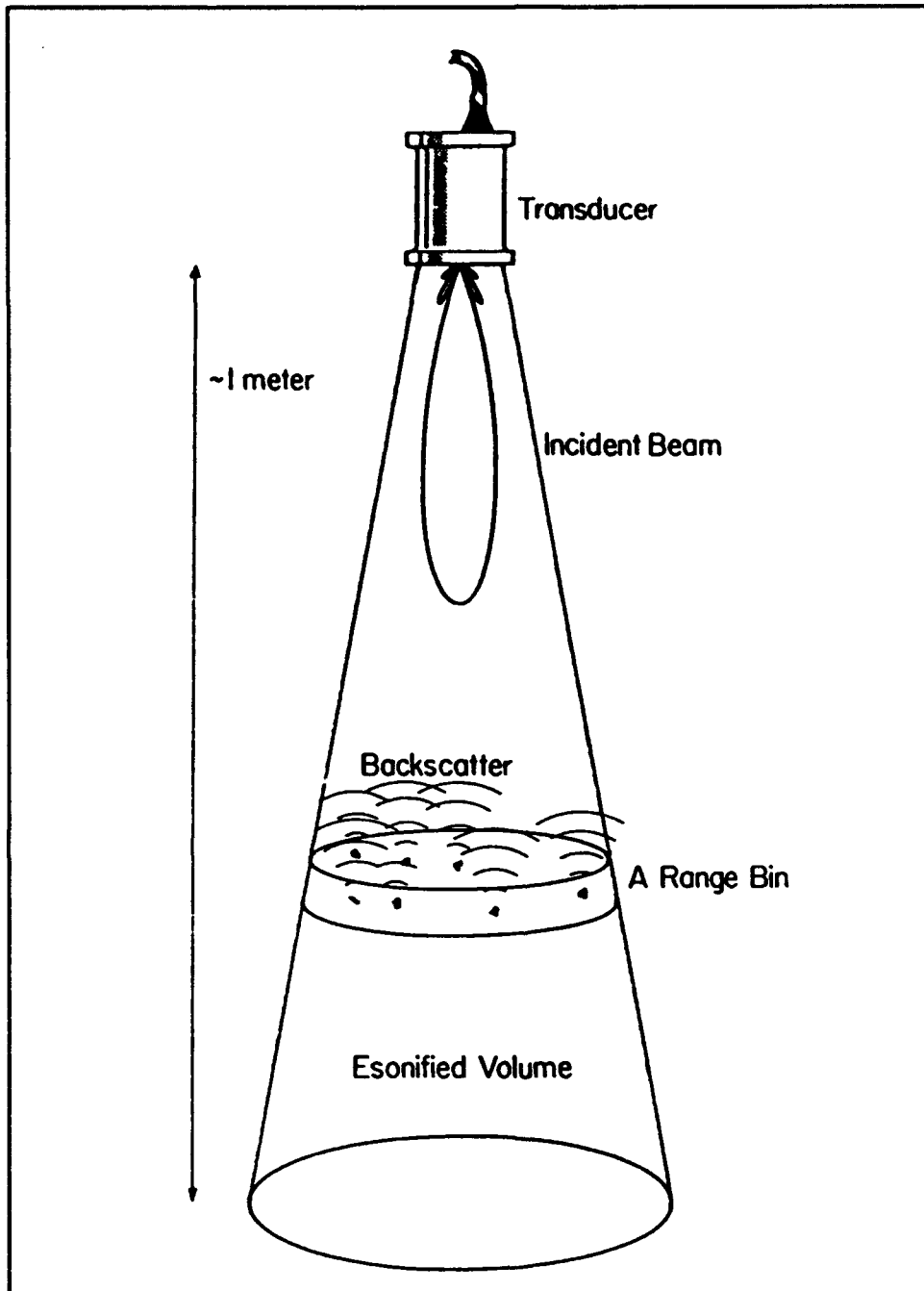

Figure 1. ACP conceptual diagram

### ACP concept

The received acoustic backscatter intensity, from a field of particles located at distance  $z$  from the transducer, at time  $t$  is given by single scattering theory as

$$I(z,t) = N + F(z,T,P) \left( \sum_i n(i,z,t) \mathfrak{A}_i a_i^2 \right) \times \exp \left( - \int_0^z 4\alpha_s(\xi,t) d\xi \right) \quad (1)$$

where

$N$  = intensity of additive noise

$F$  = response function of the instrument, at ambient temperature  $T$ , and pressure

$T$  = ambient temperature

$P$  = pressure

$n$  = number of scatterers of radius  $a_i$  and backscatter function  $\mathfrak{A}_i$  in the sampling volume

$a_i$  = radius

$\mathfrak{A}_i$  = backscatter function

$\alpha_s$  = coefficient of attenuation due to scatterers (attenuation due to the medium is handled by adjustments to  $F$ )

$\xi$  = ensonified volume

Equation 1 is basically the sonar equation with all effects not specifically related to the scatterers grouped together as  $F$ . Under the summation is the target strength of the scattering field, with energy returned to the transducer being proportional to the number of scatterers in each size class  $i$ . Finally, attenuation due to these factors causes energy to be dissipated at a rate proportional to the number of scatterers in each size class, but with a proportionality constant distinct from that appropriate to backscatter.

Under the assumption that the size distribution and backscatter function are effectively invariant in time and space (see Libicki, Bedford, and Lynch (1989) for a full discussion of the implications of such an assumption), and only the total concentration  $C$  varies, the following transformation can be made:

$$F(z,T,P) \sum_i n(i,z,t) \mathfrak{A}_i a_i^2 \rightarrow R(z,T,P) C(z,t) \quad (2)$$

where  $R$  is related to  $F$  by a constant factor, which depends upon the actual scattering population, and  $C$  is an unknown function to be determined. Equation 1 is then solved for  $C$  to obtain

$$C(z,t) = \frac{(I(z,t) - N) \times \exp \left( \int_0^z 4\alpha_s(\xi,t) d\xi \right)}{R(z,T,P)} \quad (3)$$

The response function  $R$  is determined to within a constant factor, by acoustic modeling and instrument calibration. The scaling of  $R$  is determined by comparing the concentration in a water sample taken at a known height with the received signal at that height and time. The value of the additive noise  $N$  is determined by "listen interval" experiments done during the ACP testing and evaluation process.

### Physical characteristics

The profilometer electronics, connectors, and transducer are housed in a cylindrical (12-in. by 4-in. radius)<sup>1</sup> stainless steel pressure container designed to withstand external hydrostatic pressures of more than 3,000 psi. Two O-ring sealed end caps are secured by eight hex screws driven into holes tapped in the matching faces of the cylinder's flanged ends. One end cap has the acoustic transducer mounted into its external face. The other end cap holds the electronic circuitry chassis on its internal side and a 10-pin underwater electrical bulkhead connector (that carries power to and signals from the profilometer) is mounted on the external face.

Access into the profilometer housing for inspection or repair of its contents is made by first removing the four screws holding the transducer cap, then carefully pulling it an inch or two away from the housing. The BNC coaxial cable connector to the transducer may then be unfastened, allowing the removal of the other end cap and the attached internal electronics chassis. The chassis holds three epoxy glass circuit boards, two of them printed with the transmitter and receiver circuits, and their components, respectively, and the third left blank for circuitry additions and/or modifications. Great care must be taken not to damage the O-ring seals, internal electronics, or the transducer face, with the latter requiring extra caution to avoid contact with greases, oils, or solvents that may degrade the rubber potting compound. Physical drawings and layout diagrams are included in Appendix A.

### Electronic characteristics

The profilometer (Figure 2) passes all electrical connections to the ARMS control circuitry via an underwater cable attached to its bulkhead connector. It requires an externally supplied  $\pm 15$  volts direct current (VDC), and 400 mA, to activate its circuitry. A 5-VDC key pulse provided by the ARMS microcontroller signals the transmitter, which sends a 35-W, 10- $\mu$ sec, 3-MHz tone burst out through the transducer. The transducer is then immediately switched into a receive circuit, which internally amplifies and processes the returning pulse echoes into a corresponding 0- to 5-VDC linear output. This signal is wired back to the ARMS circuitry where it is converted into digital information and stored. Transducer performance data are listed in Table 1.

---

<sup>1</sup> A table of factors for converting non-SI units of measurement to SI units is presented on page x.

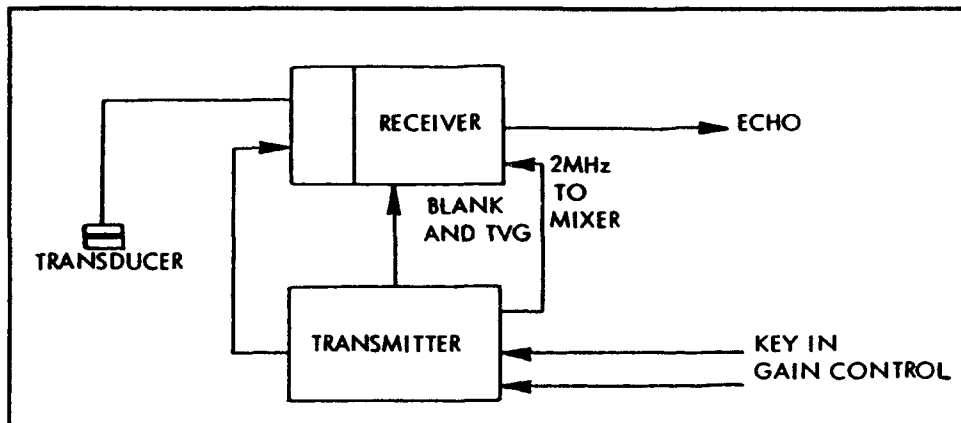

Figure 2. ACP electronic characteristics

Table 1 ACP Transducer Data	
Efficiency (min.)	30
Duty cycle (max.)	10%
Power input (max.)	2 W
Beam width at -3 dB	1° ± 0.5°
Source level (approx.)	105 dB
Side lobes/main lobe	-13 dB
Receiving response	-98 dB
Directivity index	45 dB
Maximum pressure	500 psi
Weight	1 lb

The profilometer can be keyed up to 200 times a second with full transmitter output. To conserve battery power, though, it is best to empirically determine the ideal repetition rates of the profiling function. Neutralization of high frequency configurational noise (Libicki, Bedford, and Lynch 1989) is accomplished by triggering the ACP multiple times over each desired sampling interval and ensemble averaging the individual profiles bin by bin. Both the sampling interval and the averaging scheme are software assignable and can be adjusted to provide optimal measurement in conditions of widely ranging magnitude.

The receiver circuit's sensitivity is controllable by applying a 0- to 15-VDC level to the profilometer's external gain line. In the ARMS ensemble, the gain voltage is supplied by a Digital to Analog (D/A) converter under machine control. Through onboard interpretation of the statistical distributions

of digitized values from the echo returns, pre-established protocols programmed into the operational software prevent the instrument readings from saturating by appropriately adjusting the gain voltage. Keeping the signals in the statistically significant range guarantees subsequent conversion of the data into reliable sediment concentration information.

The manufacturer-supplied time variable gain (TVG) circuit is disabled in the ARMS ACP. Although it is intended to compensate for distance-from-transducer effects on return signal strength, the TVG is not desirable in the ARMS configuration, because a more accurate treatment of the distance effects can be easily performed on the raw data during later data reduction and conversion. Another optional control is a listen-interval circuit. Installed at the Ohio State University Department of Civil Engineering, the circuit occasionally puts the transducer into the receive mode without transmitting the 3-MHz tone burst. It was used in preliminary tests to determine the background noise environment in the profilometer's frequency range. The circuit was disabled in place after proving that, due to attenuation, these background levels were insignificantly small compared to the echoes from the active pinging. A summary of the electronic specifications is found in Table 2. Detailed electronic schematics and wiring diagrams are included in Appendices B and C.

<b>Table 2 ACP Electronics Specifications</b>	
Operating frequency	3 MHz
Pulse width	10 $\mu$ sec
Power output	1 watt
Typical range	30 ft
Keying:	
External	Positive pulse, TTL compatible
Internal	200 pulses per second
Output level	TTL compatible positive pulse
Input power	$\pm$ 15 VDC at 50 mA maximum

### Data processing

The complex set of considerations pertinent to the conversion of the acoustic reflection data into representative sediment concentration profiles is covered in Libicki, Bedford, and Lynch (1989). The considerations include calibrative allowances for parameters such as ambient temperature, total suspended mass, grain size distributions, and speed of sound. As mentioned previously, all available measurements of these values will greatly assist in the data conversion procedure.

## Acoustic Velocimeter

Multiple three-dimensional measurements of velocities at discrete points in the vertical water column are needed to apply models for estimating Reynolds stresses and turbulent kinetic energies there. To detect small, turbulence-scale velocity fluctuations, non-intrusive methods must be employed to prevent introduction of flow disturbances. For that purpose, Woods Hole Oceanographic Institution scientists developed the Benthic Acoustic Stress Sensor (BASS) (Williams 1990).

### Physical characteristics

The BASS incorporates the differential time of travel of high-frequency sound caused by its propagation along a moving medium. Technological achievements such as high-speed 12-bit A/D converter chips, microprocessors, and high-frequency acoustic transducers provided the capability to quantify and record over these minute amounts of time. The result is an instrument that can make the dozens of readings, conversions, and calculations per second needed to trigger and interrogate a geometric array of acoustic sensors fast and accurately enough to provide the desired information.

The BASS transducers are mounted on a cylindrical stainless steel frame called a cage (Figure 3) with four pairs oriented 90 deg apart around the inner edge of two vertically separated mounting rings. Each transducer is tilted 45 deg from the vertical to point at the transducer opposite it on the other ring. The axes of the four pairs are coincident at the midpoint of the open cylindrical volume created by the two mounting rings. The components of velocity measured along these four vectors are input into a trigonometric solution for corresponding velocity components in the X, Y, and Z directions. The BASS cage is reinforced by two additional outer coupling rings attached by fine wire struts to the sensor assembly. The cages are bolted together end to end to form a vertical column of four cages, providing four evenly spaced locations for precise, unimpeded, three-dimensional flow measurements.

The BASS sensors are precisely aimed and aligned along the mounting rings of the cages. Even though the cages are quite sturdy, care must be taken to avoid stresses that could cause their deformation. Like the profilometer transducer, the faces of the BASS transducers must be kept clean and oil free to preserve their integrity. Tap water used for calibration and testing in the laboratory must first be allowed to stand for 24-48 hr to dissipate chlorine that could soften the potting shells.

The tiny 2-pin connectors that attach each transducer to its coaxial cable have internal fixed O-ring seals, and these should be cable-tied circumferentially on either side of the flexible seal to assure strong water-tight connections. The eight coaxial cables from each sensor cage are tied individually along the cage struts to secure and immobilize them. The cables from each

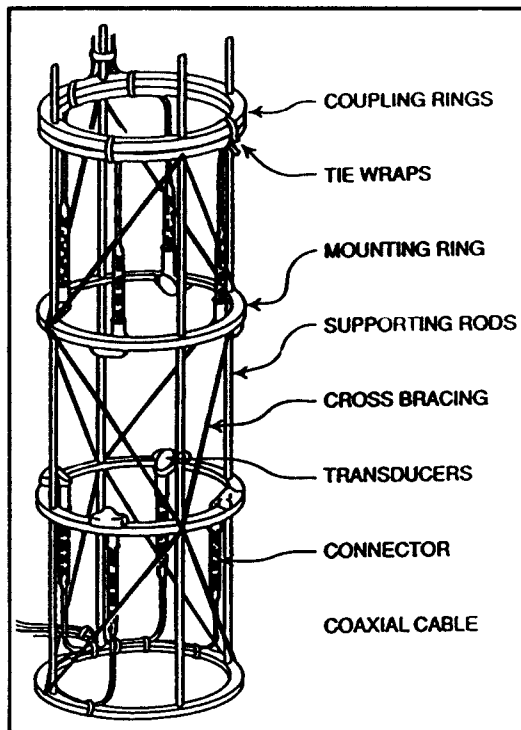

Figure 3. BASS cage

cage are wrapped together in a bundle with spiral-wrap PVC sheathing that protects their insulation jackets from abrasion, and immobilizes them with respect to each other for reduction of drifting capacitive offsets between their individual conductors. The sheathing also makes each bundle easier to handle and secure in the field, and it relieves some of the strain at the junction of the cables and the potting material that joins them to the 10-pin bulkhead connector. Care must be taken in mating these connectors to prevent bending the delicate pins of the receptacle. All O-rings must be kept clean and free of abrasions to preserve their underwater sealing performance.

### Electronic characteristics

The sensors of the four BASS cages of the ARMS system are interrogated by a microprocessor-driven circuitry package that the manufacturer, Oceanographic Instrument Systems, supplied in a 3,000-psi pressure case outfitted with end cap bulkhead connectors to feed and read the 1.75-MHz acoustic pulses through individual coaxial cables. The electronics chassis fastened to the connector end cap holds the system's printed circuit boards in edge connectors wired together as a backplane. There is a pair of receiver and transmitter boards for each of the four BASS cages, along with three timing boards, and a microprocessor board, for a total of eleven boards. The board and chassis layouts appear in Appendix A.

The microcomputer used in BASS is a 6303-based system by Onset Computer called the Tattletale V (Onset 1989). The Tattletale is programmed in TT BASIC, a special version of BASIC, with a personal computer (PC) hooked up to a 4-pin telephone jack. The operational software is stored in electronically erasable/programmable read-only memory, or EEPROM, for non-volatility under less than optimal field conditions. The small Tattletale board (Figure 4) is piggybacked onto the microprocessor board and may be disconnected to isolate its performance from that of the BASS system. The Tattletale board requires a 9-VDC (battery) power supply. Programming of the Tattletale requires an external device (dubbed "Romulator" by the manufacturer) to provide the necessary signals and voltage levels.

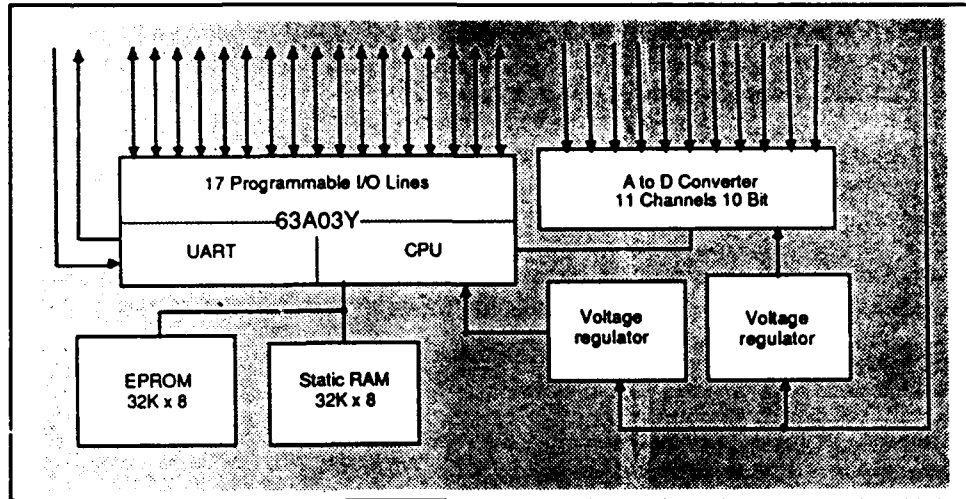

Figure 4. Tattletale V

The entire BASS package is supplied by a +24-VDC battery source, switched on as necessary by the ARMS power control circuitry. The only other lines provided external to the instrument are ground and serial data out. Inside the pressure housing, however, all of the BASS wiring is accessible. This can be exploited since there is enough spare room inside the BASS pressure housing to hold the ARMS control circuitry on a chassis fastened to the opposite end cap, as seen in Figure 5. With both in the same case, all connections between the ARMS and BASS microprocessors are short and internal, reducing noise and the probability of disruption in the field.

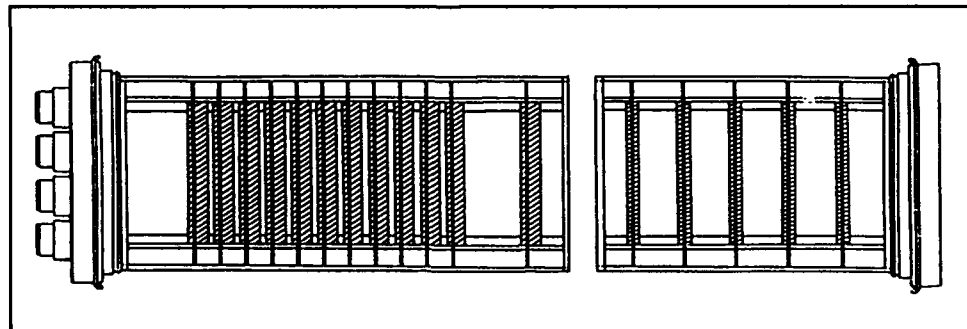

Figure 5. BASS and ARMS chassis in place

The programmability of the Tattletale allows the BASS to be configured into many operational schemes. The entire array of four sensor cages can be sampled at up to 5 Hz, which will capture enough data to enumerate most of the inertial subrange velocity fluctuations occurring at each. The programs also have the ability to keep a time clock and to include elapsed time in the data output for double-checking instrument synchronization later. The data stream is sent out from a 9,600-baud, 0- to 5-V Universal Asynchronous Receiver Transmitter (UART) directly to the ARMS microcontroller, the

format of which may be modified by changing parameters in the TT BASIC software. In most BASS programs written for use with ARMS in the field, the time clock and sampling commence immediately upon powering up to remove the need for control lines and to ensure proper reinitiation subsequent to any planned or unplanned temporary power disruption. All electronic and wiring schematics are shown in Appendices B and C.

### Data processing

The BASS electronics are laboratory calibrated to provide high-precision conversion of the propagation delays into correspondingly accurate velocity readings. BASS data output is in the form of four-bit hexadecimal bytes, four from each cage, that describe the velocities along the lines formed by each pair of transducers.

The form of the velocity component data values, centered around 0000, ranges from +4,095 bits (or 0FFF) to -4,096 bits (or F000) which correspond to +120 and -120 cm/sec, respectively. Each bit represents a 0.03-cm/sec increment in magnitude, and vector direction is described by the first hexadecimal character of each byte. The BASS electronics are programmed to replace a velocity reading with a hex 8000 (which is far out of the range of possible readings) to flag a missed measurement to prevent incorrect interpretation as a velocity value.

The four vector velocity components are converted into components in the X, Y, and Z directions (Figure 6) by applying the measured values to a set of right-hand rule trigonometric equations to obtain  $u$ ,  $v$ , and  $w$  velocities, respectively. Multiplying the differences in vector contributions between the A, B, C, and D transducer pairs with the sine and cosine components of the bit-velocity unit of 0.02931 cm/sec, the equations become:

$$u = 0.0207 * (B - B_0 - D + D_0) \text{ cm/sec} \quad (4)$$

$$v = 0.0207 * (A - A_0 - C + C_0) \text{ cm/sec} \quad (5)$$

$$w = 0.0207 * (A - A_0 + C - C_0) \text{ cm/sec, or} \quad (6)$$

$$w = 0.0207 * (B - B_0 + D - D_0) \text{ cm/sec, or} \quad (7)$$

$$w = 0.2070 * (A - A_0 + B - B_0 + C - C_0 + D - D_0) \text{ cm/sec} \quad (8)$$

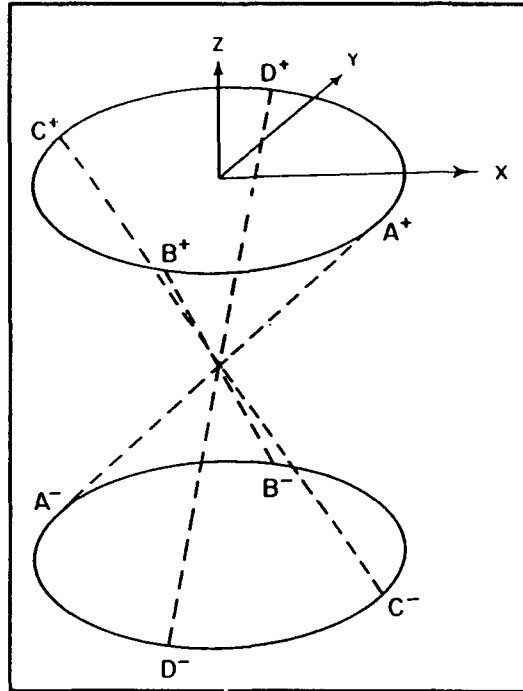

Figure 6. BASS vector representation

The zeroed values for each transducer pair, which may differ from true 0000 hex due to the previously mentioned capacitive configurations experienced in different field conditions, are figured into the equations. The zeroes are obtained at the beginning (and possibly the end) of each deployment by dipping the BASS cage array (as configured) into still water, or by wrapping it with cellophane and submerging it, to perform several minutes of velocity-free calibration. Unless the system is removed from the ARMS instrument tripod, the zeroes remain valid for the entire deployment. Physical and timing diagrams as well as electronic schematics can be found in Appendices A, B, and C.

## Pressure Sensor

Hydrodynamic pressure history over an ARMS data collection deployment is recorded using a pressure sensor, a resistive piezo-amplified transducer, Model ST-420, by Wika Instrument Corporation of Lawrenceville, GA (Wika Instrument Corporation 1989). This device's linearity and accuracy are optimal (Table 3) for the intended deployments. The accuracy of the ST-420 model is a percentage of full scale, so the pressure range version should be matched to the required application for best performance (Table 4). However, the accuracy of each version always is finer than the desired level of digital resolution, which in shallower areas, is on the order of 2 cm of freshwater equivalent.

The ST-420's piezoresistive element is protected from the wetted pressure port by a stainless steel diaphragm and an intermediate isolating filling that enhances its long-term physical integrity. The transducer's amplifier electronics, that boost its output to 0-5 VDC over its pressure range, are encapsulated in a silicone gel for protection from environmental effects. The package requires only application of +10 to +30 VDC to initiate signal output to the ARMS controller.

<b>Table 3 Wika ST-420 Pressure Transducer Specifications</b>	
Overall accuracy	± 0.25% of full scale (best fitting straight line, BFSL)
Output signal	0-5 VDC, 3-wire
Supply voltage	10-30 VDC
Supply voltage error	<0.1% of full scale/10 V
Linearity	<0.25% of full scale
Hysteresis	<0.1% of full scale
Repeatability	<0.1% of full scale
Process temperature	-20°F to +220°F
Ambient temperature	-10°F to +180°F
Storage temperature	-40°F to +220°F
Temperature error	<0.005% of full scale per 1°F (32°F to 180°F)
Max. overpressure	See above
Body-Material	304 stainless steel
Wetted parts	316 stainless steel (up to 250 psi) 17-4 PH (500 psi and above)
Process connection	½ in. NPT (standard)
Electrical connector	DIN 43650 solderless screw terminals
Electrical protection	Against reverse polarity; against short circuit output; suppressor-diode for high-voltage protection
Vibration protection	Internal electronics 100% potted with silicone gel
Weight	Approx. 8 oz.
Dimensions	See drawing

The ST-420 is housed in a stainless steel assembly with a 1/2-in. NPT threaded pipe fitting (Figure 7). This is fastened through the end cap of a small underwater casing for use on the ARMS frame. The other end cap has an underwater bulkhead connector that allows connection with ARMS via underwater cable.

**Table 4  
Pressure Transducer Ranges Available**

Pressure Ranges	Maximum	Burst
0 - 30" vacuum	20	50
30" - 0 - 30 psi	100 psi	250 psi
30" - 0 - 60 psi	150 psi	300 psi
30" - 0 - 100 psi	250 psi	500 psi
0 - 5 psi	15 psi	30 psi
0 - 10 psi	20 psi	50 psi
0 - 25 psi	100 psi	250 psi
0 - 50 psi	150 psi	300 psi
0 - 60 psi	180 psi	300 psi
0 - 100 psi	250 psi	500 psi
0 - 160 psi	400 psi	1,000 psi
0 - 250 psi	600 psi	1,500 psi
0 - 500 psi	1,000 psi	2,000 psi
0 - 750 psi	1,500 psi	3,000 psi
0 - 1,000 psi	2,000 psi	4,000 psi
0 - 1,500 psi	3,000 psi	6,000 psi
0 - 3,000 psi	5,000 psi	10,000 psi
0 - 5,000 psi	10,000 psi	15,000 psi
0 - 8,000 psi	12,000 psi	17,000 psi
0 - 10,000 psi	15,000 psi	20,000 psi
0 - 15,000 psi	20,000 psi	25,000 psi

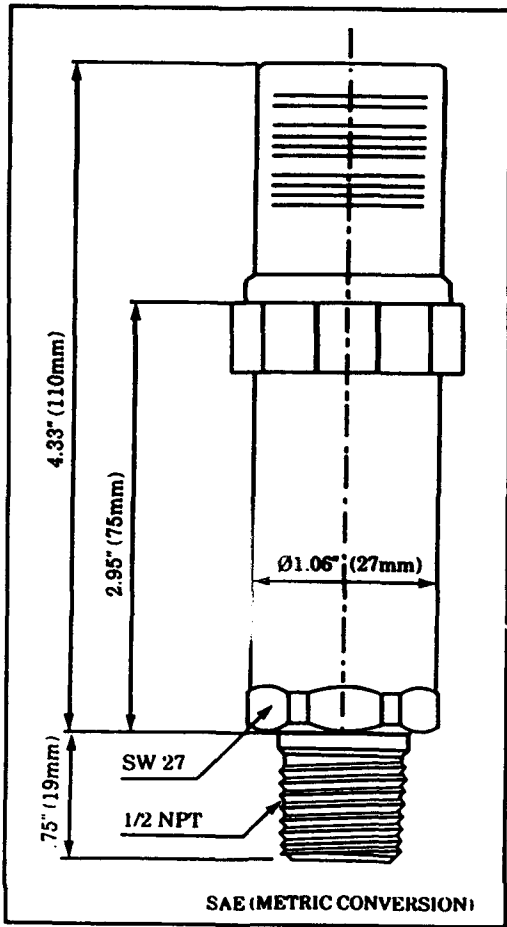

Figure 7. Wika ST-420 pressure transducer

## 4 Ancillary Instrumentation

---

To complete its self-contained suite of capabilities aimed at thorough reconnaissance of all local hydrodynamic activity, a secondary level of ARMS instrumentation is required. Sensors measuring tripod attitude and the back-ground water column environment in the tripod's vicinity are listed in this chapter.

### Inclinometer

#### Functions/utilities

The ARMS tripod design allows it to be repeatedly placed into an upright position with the vertical axes of the velocity sensors aligned perpendicularly to the seafloor. However, seldom are field sites encountered that are completely free of at least a somewhat gentle bottom slope. To account for any tilt of the local X-Y-Z coordinate system during the subsequent data reduction process, an inclinometer is fastened to the top of the BASS cages to record their deviation from gravitational vertical.

#### Instrument characteristics

The Lucas Sensing System Accustar II dual-axis inclinometer (Figure 8) is an economical unit small enough to be enclosed in a compact Plexiglas housing and mounted unobtrusively atop the velocity sensor array (Lucas 1990). It utilizes a variable capacitance sensor that permits two forms of output; an analog voltage level and a pulse-width-modulated (PWM) digital signal. Both forms are decipherable by the ARMS conversion circuitry, although the analog version is slightly more compatible with the outputs of the other instruments used. The device's excellent resolution and linearity make it well-suited for long-term monitoring of tilt during a deployment. Furthermore, combined with the time constant of the sensing mechanism, it is valuable for discerning any unwanted vibratory oscillations that may appear in the ARMS data. Environmental, electrical, and performance specifications of the inclinometer are listed in Tables 5, 6, and 7, respectively.

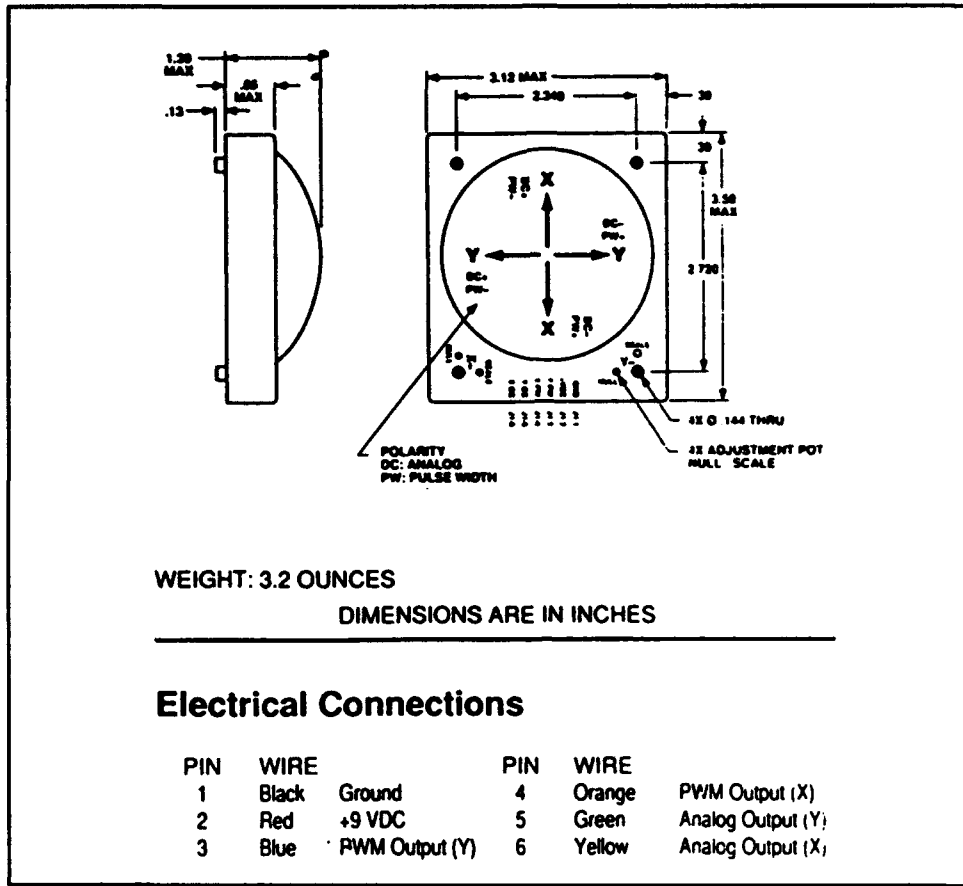

Figure 8. Lucas Accustar II dual-axis inclinometer

Table 5 Inclinometer Environmental Specifications	
Temperature range	
Operating	-40 to +85°C
Storage	-55 to +85°C
Temperature coefficient of null	± 0.01° per °C
Temperature coefficient of scale factor	± 0.10% per °C

## Compass

### Function

To prevent the tangling of multiple tethers during its placement, the ARMS tripod is lowered to the bottom using a single cable. The cable is hooked to a

<b>Table 6 Inclinometer Electrical Specifications</b>	
Voltage supply nominal	+9 VDC
Voltage supply range	+5 to +15 VDC regulated
Current	3.5 milliamps maximum
Analog output	
Scale factor @ +9 VDC	100 millivolts per degree
Load resistance	10K ohms minimum
Pulse Width Output	
Null 50%	
Scale factor	= 0.7 % per degree or = 14 $\mu$ sec per degree
Duty cycle	$t_2/(t_1 + t_2)$ ; $t_1$ & $t_2$ vary from 0.2 to 0.7 millisecond
Frequency	= 1kHz nominal

<b>Table 7 Inclinometer Performance Specifications</b>	
Range	$\pm 20$ deg
Threshold & resolution	0.01 deg
Linearity	
null to 10 deg	$\pm 0.2$ deg
10 to 15 deg	2% of reading
15 to 20 deg	Monotonic
Null repeatability	$\pm 0.1$ deg
Time constant	0.3 sec
Frequency response	0.5 Hz

lifting ring bolted to the center of the upper part of the tripod's central frame. This arrangement allows a balanced descent, but it relinquishes topside control of the tripod's directional orientation as it settles into place on the bottom. To provide a record of the initial orientation as well as any subsequent rotational shifting during a deployment, a compass is mounted in the Plexiglas pressure container (housing the inclinometer) that is fixed to the BASS array.

#### **Instrument characteristics**

The ARMS compass is an Aanderaa Instruments Model 1248 potentiometric version designed for use in recording current meters (Aanderaa Instruments

1972) (Figure 9). The device's directional orientation is given as a potentiometric setting. The central magnet assembly in the compass normally rotates freely in a plane normal to the vertical axes of the velocity sensors, keeping itself aligned with and pointing toward magnetic north. An attached wire wiper passes closely along a wound wire potentiometric ring molded into the housing of the compass.

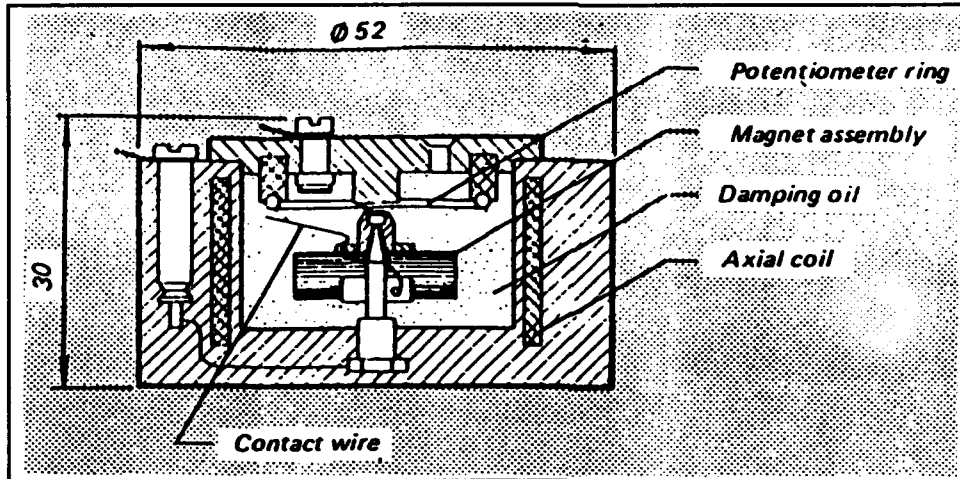

Figure 9. Aanderaa Model 1248 potentiometric compass

When a compass reading is required, the ARMS power control actuates a +6-VDC, 15-mA clamping current to a coil surrounding the magnet assembly. When clamped, the wiper makes contact with the ring. Because the potentiometer is wired as a linear voltage divider, the resistance value yields a voltage output that is directly proportional to the existing orientation of the compass and, consequently, to the attached velocity probes.

The specifications of the compass are listed in Table 8. Signal conditioning, power control, and pressure container information for the tilt/direction instruments are found in Chapters 7, 8, and 9, respectively, of this report. Engineering drawings are included in Appendix A.

<b>Table 8 Compass Specifications*</b>	
Clamping voltage	6 volts
Clamping current	15 milliamps
Potentiometric resistance	2,000 ohms
Allowable tilt	12 deg
Accuracy	± 2 deg
* Time for true reading after compass is suddenly turned 90 deg is 3.5 sec.	

## Thermistor

The background water temperature is necessary for determining the local speed of sound, for precise calibration of the acoustical instruments. Temperature variations at the ARMS tripod result from random turbulent or wave-induced motions with time scales ranging from seconds to hours. It is therefore desirable to take a continuous, high-frequency water temperature record at the ARMS site.

### Instrument description

Hundreds of different temperature sensors are available, many of which may be easily incorporated into the ARMS ensemble. Experience with the YSI Company's YSI44204 Thermilinear® Component shows it to be a very accurate sensor (YSI 1977). The precise YSI#44018 thermistor can be configured into two circuits if a pair of low-temperature coefficient resistors is included to form a highly linear voltage or resistance network, depending on which output is desired. ARMS can use either form interchangeably, since the electronics of the component are mounted on the system's signal conditioning board.

The thermistor itself (Figure 10) is potted directly onto a cable connector that mates to a bulkhead connector through the pressure housing end cap. This thermistor plug is easily removable and reattachable, and it is free of an external signal cable. For remote placement, the plug may be mated with a matching receptacle at the end of an underwater cable. Thermistor network specifications are listed in Table 9. Schematic diagrams are found in Appendix B.

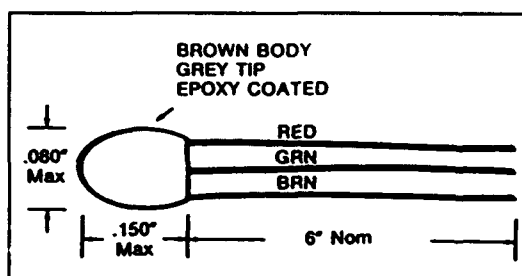

Figure 10. YSI #44018 thermistor composite

of sediment particles entrained in the water column, like the temperature, varies as independent water masses move advectively through the study site. Also, the local boundary layer environment will provide a resuspensive contribution to the total suspended mass per unit volume (TSM). Although these long- and short-term variations can be seen in the profilometer data, a supplemental measurement, obtained using a different method (optical instead of

## Optical Backscatter Sensor (OBS)

### Utility

As with the temperature record, concurrent background suspended solids measurements can further enhance the quality of the ARMS data set. The amount

<b>Table 9 YSI Thermistor Specifications</b>		
<b>Specification</b>	<b>Voltage Mode</b>	<b>Resistance Mode</b>
Thermistor absolute accuracy and interchangeability	$\pm 0.27^\circ \text{ F}$	$\pm 0.27^\circ \text{ F}$
Linearity deviation	$\pm 0.055^\circ \text{ F}$	$\pm 0.98 \text{ ohm}$
E <sub>in</sub> Max	4 v	
I <sub>T</sub> Max		685 microamps
Sensitivity	$0.0031289 \text{ Ein}^\circ \text{ F}$	$17.834 \text{ ohms}^\circ \text{ F}$
Load resistance	10-Megohm minimum	
Time constant	The time required for the thermistor to indicate 63% of a new impressed temperature, in 'well-stirred' oil, 1 sec; in free still air, 10 sec.	
Storage temperature	-112 to +250° F (-80 to +120° C)	

acoustic), may reveal clues to behavior not readily decipherable from the acoustical returns. The optical result of increased sediment concentration is increased opacity, or turbidity, of the water column. The profilometer is well-suited to penetrating the entire boundary layer to reveal the fine scale spatial structure of the evolving suspended sediment profile. Light, however, is very rapidly attenuated while traveling through turbid water; thus, the effective path lengths of light-based instruments are limited by the range of TSM that they will operate in. Nevertheless, a properly applied optical measurement, even if taken at a single point along the acoustically obtained profile, provides a useful corroborative comparison between measurements in a wide range of applications. A discussion covering all available devices and methods they employ is available in Bedford, Wai, and Libicki (1991). A specific device easily adaptable for use with the ARMS instrumentation, the optical backscatter sensor (OBS), is mentioned here.

### **Instrument description**

The OBS® sensor, made by D & A Instrument Company (D & A Instrument Company 1991), is a device that measures particulate optical backscatterance of an 875-nm infrared (IR) light source. Its silicon photodetector selectivity responds to IR reflections from a narrow (140 to 160 deg) angular range (Figure 11) that provides a linearly proportional voltage output in response to ambient turbidity levels. Conversion of turbidity readings to TSM values is possible if the sensor is calibrated properly with suspended material from the monitoring site.

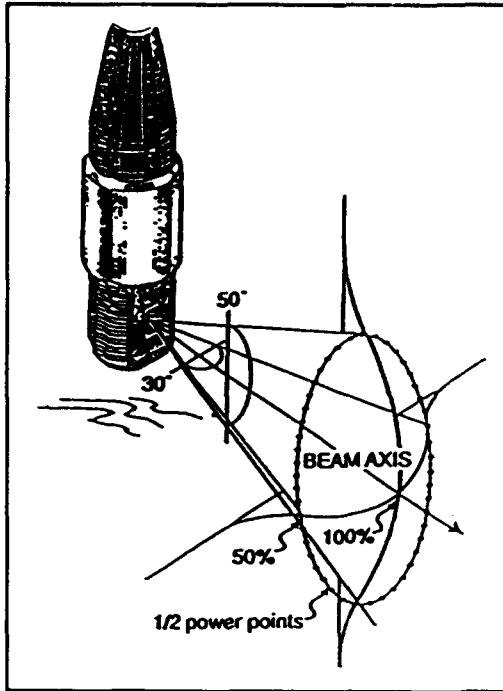

Figure 11. OBS

The OBS sensor is constructed of corrosion-resistant, glass-filled polycarbonate with injection-molded connectors. It is made available as a temperature-compensated, stand-alone device (in an underwater pressure housing) that accepts external gain and offset adjustments. The 0- to 5-V output range is directly compatible with the ARMS digital conversion circuitry and the sensor requires only 14 mA of current at +7 to +15 VDC. Detailed diagrams are included in Appendix A.

### High-Frequency Acoustic Non-Destructive Sediment Sizer (HANDSS)

To provide grain size distribution calibrations for the ACP and OBS sensors, the High-Frequency Acoustic Non-Destructive Sediment Sizer (HANDSS) is currently being developed. HANDSS incorporates five acoustic transducers, ranging from 2.25 to 50 MHz, to estimate particle size spectra at the ARMS field site. The transducers measure both close-range backscatter and attenuation of reflections off a nearby fixed hard target. This provides the suite of necessary signals to adequately define the local sediment size characteristics.

HANDSS is a stand-alone device housed in an underwater pressure container (Figure 12). One end cap of the canister holds all transducers and the hard target mount. Controlled by an HPC 16000 series microcontroller, HANDSS does all necessary computations on board and outputs its data in an RS-232 serial format. The output is fed to ARMS through an underwater cable that carries power to the device.

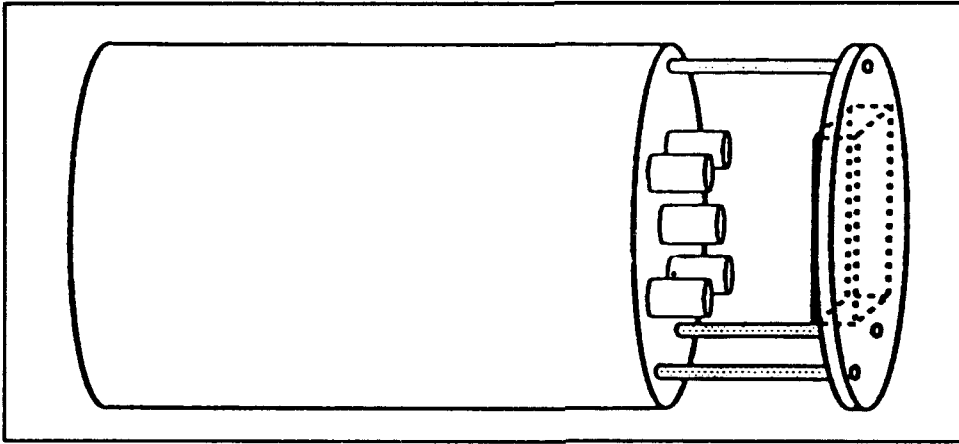

Figure 12. HANDSS

## 5 Field Configuration

---

This section outlines considerations regarding placement of the underwater instruments relative to each other and to local topography. After establishing these requirements, their application towards optimal design of the ARMS tripod is discussed.

### Design Considerations

With two profiling instruments sampling the benthic boundary layer within the 1- to 5-Hz domain (the BASS measuring velocities and the ACP measuring concentrations) it is desirable to have them measuring the same profile (Bedford et al. 1991). It is not possible to have both instruments simultaneously measuring exactly the same volume of water due to several factors. While the BASS should be mounted so that all four cages are aligned vertically, the ACP should be tilted slightly off vertical a few degrees. This is done to avoid strong secondary and tertiary bottom reflections off the faceplate that can linger long enough to be picked up by the receiver, fouling subsequent profiles. This and the interference of side lobe reflections from any objects off center in the very near field make it impractical to aim the ACP straight down through the center of the BASS cages.

### Instrument-relative positioning

The two measured profiles should be positioned as proximally as possible without mutual interference. The vertical plane of the tilted ACP beam should contain the line formed by the midpoints of each BASS cage. To achieve this, the profilometer should be mounted near the top of the BASS cage array and tilted away (Figure 13). Tilt in this direction reduces the side lobe effects, and maintains a proportional distance between the lower BASS cages and the widening profilometer beam. The profilometer needs to be separated about 20 cm horizontally from the BASS cage so as to eliminate spurious reflections. Consideration of the relative geometry of the two profiles during analysis allows the data from each to be properly applied and investigated.

The pressure terms in the governing boundary layer equations are usually directly related to the time history of the surface and internal wave velocity

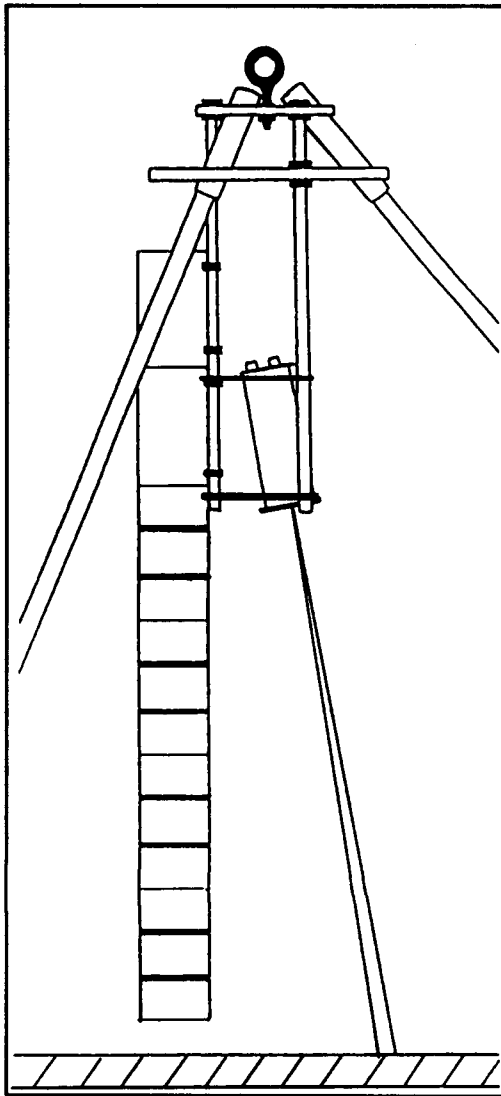

Figure 13. BASS-ACP positioning

components. Therefore, the pressure readings should be taken at a point vertically aligned with the midpoints from the velocity readings. Since locally observed pressure is a result of hydrostatic pressure variations, the vertical spacing between the upper BASS sensor and the pressure transducer is not as crucial as the alignment. However, to minimize the effects of any lags that may occur, it is best to mount the pressure transducer as close to the top of the BASS array as possible without blocking the flow patterns.

### Seafloor-relative positioning

As mentioned in the ACP description, a thorough reconnoitering of the sediment concentration profile should include the reflection off the seafloor itself. Also, the ideal placement of the bottommost BASS sensor would be as close to the bottom as possible without actually causing disturbances at the water-sediment interface. These considerations, along with those concerning instrument-relative positioning, serve to constrain the mounting design options dramatically.

Within these peripheral limits, it may become desirable to alter the positions of the acoustic instruments in order to fine-tune them for specific field environments or alternative sampling requirements. However, once the devices are mounted in an optimal configuration, it is necessary not only that they remain motionless in these positions relative to the seafloor during an entire deployment, but that they have the capacity to be repositioned precisely and rapidly in the same fashion at other bottom sites. This allows the collection of many directly comparable field data sets, each free of peculiar oscillations resulting from sympathetic instrument vibrations.

Being able to place the ARMS instruments in the same positions relative to the boundary layer at different sites is not enough to ensure the compatibility of the separate data sets. The supporting structure itself must be designed to maximize the unimpeded movement of water and sediment from all directions.

Any solid structural members substantial enough to secure the profilometer and BASS in high-energy conditions will disrupt flow patterns locally. If the scale and location of these disturbances do not interfere with the sampling volume, then the benefits gained from using the acoustic instruments to unobtrusively observe in situ benthic boundary layer activity will not be compromised.

### **Deployability**

Occasionally the instrument package may be placed at sites where power and serial communications cables would be employed to link it directly to external power supplies and/or computer hardware nearby, e.g., in a shore facility or aboard a moored vessel. The majority of the deployments will be at remote areas, where the ensemble would collect data autonomously. In both situations, the equipment will need to be manually hoisted clear of the decks of various vessels, then lowered through the air, water surface, and water column to the seafloor, and released. This operation may be required to proceed under a wide variety of weather conditions.

To account for this, the instrument pod needs to be self-contained enough to avoid any damage or disconnection due to the sometimes unavoidable rough handling it may receive. Long delicate appendages, unsecured cables, and exposed connectors could be subjected to many destructive stresses during deployment and must be avoided. Besides enhancing instrument survivability, a balanced, compact, and ruggedly designed platform will be generally quicker and easier to handle, requiring fewer deckhands. Getting it to the seafloor quickly and effectively reduces the total amount of time the system spends precariously attached to a bobbing vessel, and it reduces ship time on station.

### **ARMS Tripod**

The ARMS tripod is the result of a comprehensive design process consisting of field experiences, laboratory tests, and structural analyses. The design considerations ranged from availability of materials to flow field signature while attempting to cover all fine points optimally.

#### **Platform design**

As observed in similar applications in telescoping, photography, and surveying, the most stable geometric design for use as a precision instrument platform is the tripod. As long as it is lowered into place in a relatively upright attitude, a tripod will settle firmly on the seafloor without wobbling regardless of any local bottom contour. Keeping the vertical axis of the center of gravity aligned with the intersection of the three legs is enough to facilitate this upright deployment position in all but the most extreme wave and/or current environments.

The ARMS tripod (Figure 14) utilizes a sturdy central frame that serves as a stable instrument perch when joined to three solid legs. The three evenly spaced angled sleeves that accommodate the legs are welded between two vertically separated 3/4-in.-thick disks of aircraft aluminum. These sleeves each have three 3/8-in. clearance holes that line up with holes drilled in the tops of each leg, allowing stainless steel bolts to secure them once the legs are slid into place. Three 1-in. stainless steel threaded rods pass vertically through clearance holes drilled in the two aluminum disks and can protrude as much as 36 in. downward, depending on how they are fastened into place with stainless steel hex nuts and washers.

The expandable and interchangeable legs are cut to their desired length from readily available 2-in. galvanized steel pipe. Twelve-in.-diam aluminum footpads are fitted to the bottom of each leg and bolted securely in the same manner as the upper sleeves. The feet allow the tripod to settle evenly onto the seafloor without sinking. Each foot has a clamped fitting drilled through it to hold an optional bottom-penetrating spike, which could restrict sliding of the feet when the tripod is placed on smooth surfaces in high-velocity conditions.

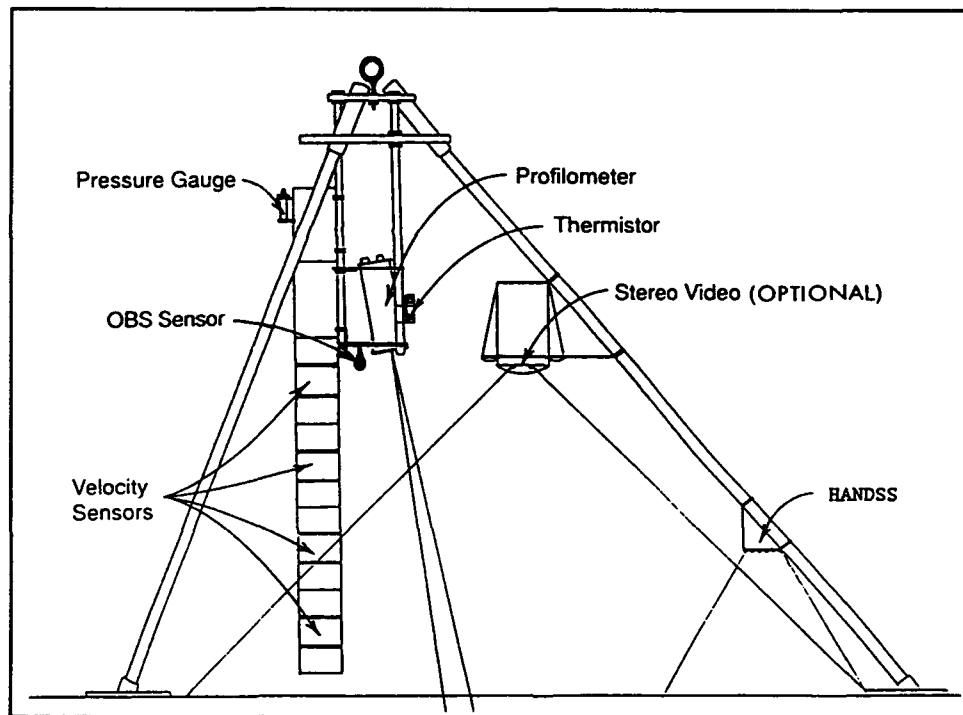

Figure 14. ARMS tripod

Tripod height can be changed by substituting legs of different length, but the optimal instrument positions described previously dictate a preferred tripod height. The diameter of the legs and their angle relative to vertical are a result of the compromise between rigidity and spacing considerations. Short stout legs are more rigid than long slender ones, but they present a larger cross-sectional obstruction to local flow fields. To arrange the legs farther from the

sampling area (below the vertex of the tripod), they could be angled out shallowly, but this requires the legs to be longer to achieve the same height, thus increasing susceptibility to torsional flexure. The chosen combination of angle, length, and diameter of the legs satisfactorily addresses all stated requirements.

### **Mounting**

The main ARMS instruments are attached via customized mounts to the three vertical threaded rods of the tripod's central frame. As stated before, the overall positioning of the rods may be changed by adjusting the hex nuts holding them to the frame. Using additional hex nuts to clamp them into place, the instrument mounts may also be positioned securely anywhere along the lengths of the three threaded rods. Utilizing these degrees of adjustability, the instruments may be placed precisely as needed to meet all dimensional requirements.

Mounted below the disks of the central frame, the instruments are afforded a degree of protection from objects dropped or towed from the surface, such as nets, downriggers, or anchors. The angled tripod legs also marginally guard the perimeter of the large open area of seafloor beneath the instrument from drifting litter. The rods and undersides of the upper legs are also ideal places to mount the electronics canisters and batteries out of harm's way. This arrangement also effectively reduces the lengths of vulnerable cables needed to connect the closely spaced components, and it keeps the cables entirely beneath the protective canopy.

# 6 ARMS Control System

---

## Overview

To downsize the ARMS instrument package from its bulky predecessors and provide the most flexible sampling and control characteristics, the latest, most technologically advanced electronics are used; integrated circuitry. The control circuit, oversized for extra performance and expandability, and a well-integrated microcontroller, paired with a versatile programmable logic device, provide the entire suite of signals and ports required to run the ARMS system.

## Requirements

### High speeds

To run an array of underwater acoustic instruments, a sophisticated set of electronic hardware must be employed. Since data from several instruments are collected in real time, high-speed circuitry is required, not only for the generation of the high-frequency sound itself, but also for the timing of the tonal bursts sent out, whether in packets, wave groups, or individual pulses. The digitization of received signals must be precise, so as not to induce any computational noise or aliasing of the coherent returns. While all of this is happening, real-time communication controls must be in place to feed raw and computed data onto mass storage efficiently, as well as signal the control hierarchy of any problems, overflows, or redirections necessary. Simultaneously, the central processing unit (CPU) must remain alert to interrupts coming from the outside, such as operator intervention or conditional shutdowns during "uninteresting" periods of non-collection. All of these functions need to be software-programmable to allow adaptive changes of operational parameters.

### Low power

The high-speed circuitry must be as efficient as possible, because the remote data platform will rarely have the convenience of an unlimited power supply. In fact, unless close to shore or dockside, the ARMS package must

always rely on battery power. Voltages should ideally be kept low, with just enough power to run the necessary routines. Fortunately, the background amount of stray radio frequency and electromagnetic frequency noise decreases rapidly with depth of water, so that low operating control and signal voltages may be used. Care must be taken, however, to identify local sources of electrical interference of larger amplitudes, especially static electricity. Battery longevity is also enhanced by occasional "sleep" periods where system functions are suspended during the previously mentioned programmed intervals or conditionally uninteresting periods.

### **Minimal size**

The physical size of the unit must be minimized as well. Minimal physical sizing allows the pressure containers holding the data collection circuitry to be placed closer to the sensors themselves without disturbing the flow around them, thus reducing the antenna effect of long cables. Also, the smaller pressure vessels are less buoyant and require less bulky ballasting for ease of handling above and below the water surface. Optimization of the mass storage machinery allows a certain amount of long-term storage given the actual bytes per second being collected, which imposes its own set of size versus length-of-deployment considerations, usually on the same time scale as available battery life. Furthermore, the amount of circuitry needs to be optimized to allow the required number of input/output (I/O) ports and timing signals without accumulating too much electronic chip overhead.

## **Microcontroller**

### **Control and computation**

The above requirements are met using the HPC 16000 series microcontroller by National Semiconductor (Figure 15) (National Semiconductor Corporation 1987). This microcontroller is really a compromise between a full-size microcomputer (with an extensive set of command functions and internal logic capabilities) and a programmable controller (a smaller dedicated functional machine usually relegated to certain I/O and control functions). Although it is not a true microcomputer, the HPC 16000 is still able to function almost completely as a stand-alone device. At 20 MHz, it is fast enough to perform complex coded instruction combinations allowing real-time control of the ultrasonic instruments as well as the rapid data transfers to process the voluminous incoming data quickly. Along with the required speeds, the HPC™ has enough I/O and computational ability to make a perfect CPU for the ARMS package (Table 10). The 32- by 16-bit divide and 16- by 16-bit multiply capabilities allow enough accuracy to process the incoming data from sensors in either 8- or 16-bit formats, interchangeable by modifying software rather than hardware.

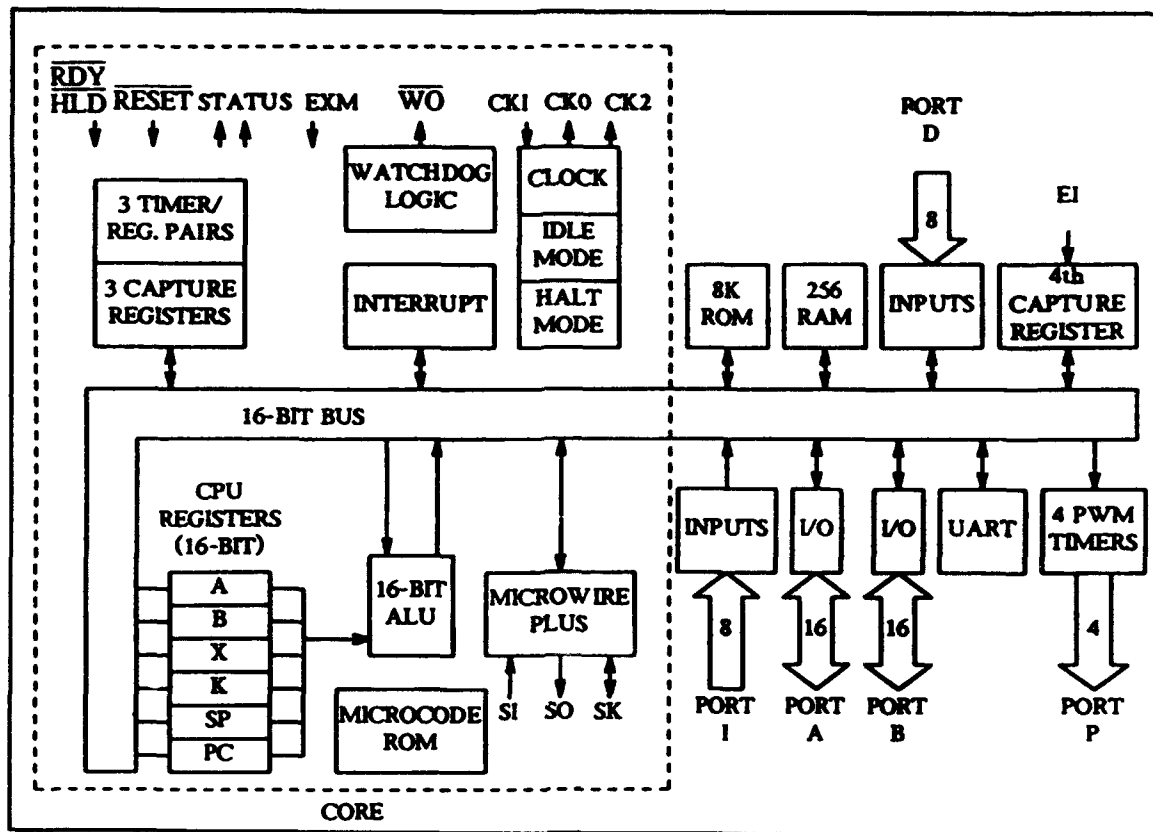

Figure 15. HPC 16000 microcontroller block diagram

## Communication

In the HPC 16000, the independently assignable data transfer rates (up to 38.4K baud) and receiving and transmitting full duplex UART allow various communication possibilities, especially when combined with the External UART Interrupt (EXUI) or software-specified interrupts. The proprietary Microwire™ serial I/O can be used with any number of other National Semiconductor Microwire™ devices that may enhance or add extra functions to the controller. This can also be used for timing and control, and to supplement the nine 16-bit timers on board the HPC™, which may be tied to up to 10 timer outputs for a wide range of controlled synchronous or PWM functions.

## Power

The HPC™ has HALT and IDLE modes for reduced power consumption during the conditional or prearranged "off" times associated with staggered long-term sampling schemes. The hardy CMOS (complementary metal oxide/silicon) circuitry, while still static sensitive and requiring some handling

**Table 10  
HPC Features**

■ HPC family—core features:
— 16-bit architecture, both byte and word.
— 16-bit data bus, Arithmetic Logic Unit, and registers.
— 64k bytes of external memory addressing.
— 200 ns for registering instructions when using 20-MHz clock.
— High code efficiency — most instructions are single byte.
— 16 × 16 multiply and 32 × 16 divide.
— Eight vectored interrupt sources.
— Four 16-bit timer/counters with four synchronous outputs and WATCHDOG logic.
— MICROWIRE/PLUS serial I/O interface.
— Complementary Metal Oxide Silicon (CMOS) — very low power with two power save modes: IDLE and HALT.
■ UART — full duplex, programmable baud rate.
■ Four 16-bit timer/counters with pulse-width-modulated outputs.
■ Four input capture registers.
■ 52 general-purpose I/O lines (memory mapped).
■ 512 bytes of random access memory (RAM) on chip.
■ Wide voltage supply range: 3V to 5.5V.
■ Commercial (0 to +70°C), industrial (-40 to +85°C), automotive (-40 to +105°C), and military (-55 to +125°C) temperature ranges.

precautions, draws small amounts of power while performing all signalling, transfers, and controls at the desirable +5-V level, making design changes simple as well as power-conservative. Electronic schematics and board layouts are found in Appendices A and B.

## Programmable Logic Device

One drawback of the microcontroller format is the small amount of RAM - only 512 bytes on the specialized 16004 series, and 256 bytes on all other models. Unfortunately, the only read-only memory (ROM) version is available in mask-programmed large-quantity purchases of 12,500 pieces or more, which is not compatible with the small-to-moderate quantities required for research projects. Therefore, the required memory must exist off-chip. For larger data and instruction set formats, latches for transfers as well as the memory chips become important required hardware on the microcomputer. Unfortunately, these would need to be hooked directly to the 16000's principal I/O and address port, which would necessitate further latching control of any other

devices requiring similar direct access or branching. To handle these requirements, a quasifunctional integrated circuit (IC) called a Programmable Logic Device (or PLD) was added to the circuitry.

## **Memory**

A User-Configurable Peripheral w/ Memory (Figure 16) is an extremely flexible PLD that possesses - in one chip - all of the extra devices needed to expand the microcontroller into a fully functional microcomputing engine (WSI 1990a). With built-in CMOS and low power consumption, the WSI PSD 301 (like the HPC™) can function in both the byte (8-bit) and word (16-bit) modes interchangeably, allowing mixing of data sizes and a wide range of addressing capabilities (Table 11). This includes the partitioning of the on-chip EEPROM (electronically erasable programmable read-only memory) (256K as 32K × 8 or 16K × 16) and SRAM (static random access memory) (16K as 2K × 8 or 1K × 16). The EEPROM, divided into eight equal mappable blocks of either 4K bytes or 2K words, is large enough to hold software programs consisting of even the most lengthy instruction sets of op codes. The SRAM is spacious and flexible enough to be used for almost any combination of onboard computations possible, as well as the direct access of data to and from address/data ports. As mentioned before, if not for the highly integrated nature of the PLD, the microcontroller design would have to include two octal latches, two 8 × 16K EPROMS, two 8 × 1K SRAMS, plus a field-programmable gate array and at least three separate port transceivers to even approach duplicating its performance.

All of the hardware and software needed to incorporate the PSD 301 into a system is available in a design kit that includes two PLCC (plastic leaded chip carrier) version samples. The chip's EPROM is programmed by a simple menu-driven personal computer interface consisting of three levels: a top-level menu, an environment in which the user selects all options and parameters required for device configuration, and a routine that controls the programmer to handle the actual programming of the device. There are three versions of the 301 available, each with a different access speed tolerance. For use with the microcontroller running at 20 MHz, the version with the "fastest" access time of 120 ns is well within the required timing limits.

## **Program address decoder (PAD)**

The device's operational mode is set up by assigning on or off values to each of 45 bits in a non-volatile configuration menu during the programming phase. These bits, not accessible during program execution, control a programmable address decoder, or PAD, which designates various functional aspects of the chip's ports, control lines, and memory. Some of the configurational bits assign active polarity levels for certain control pins such as reset and read/write, while others initialize the electronic status of I/O ports. A security bit, when set high, prevents reading of the PAD configuration and of the internal code of the PLD. With the  $\overline{CS1}$  bit set low, the 301 can be put

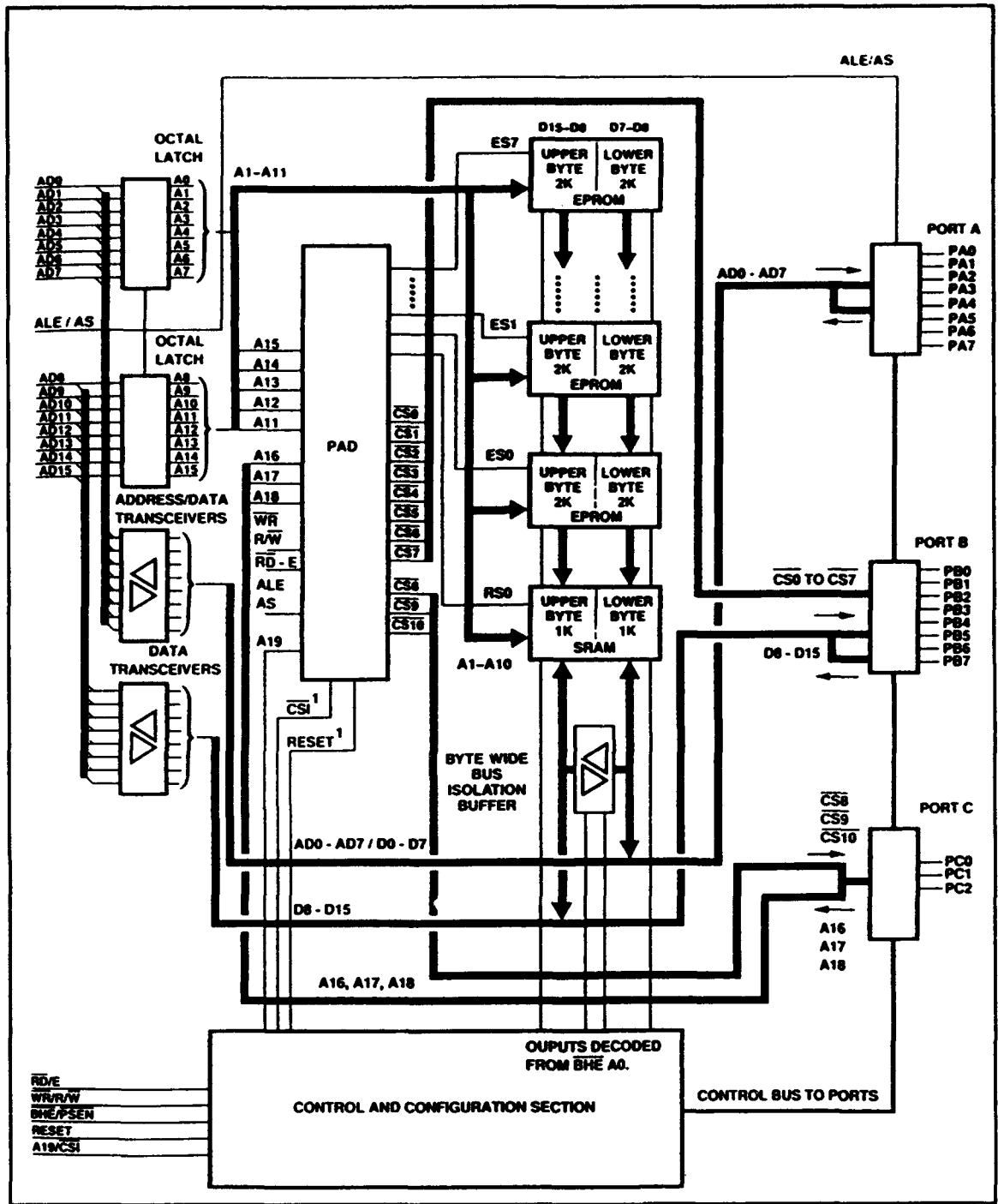

Figure 16. PLD block diagram

<b>Table 11 PLD Features</b>	
■	Second generation programmable system device
■	User-configurable peripheral for microcontroller-based applications
—	Enables rapid design implementation and fast time to market
■	Available in space-saving surface mount and through-hole packages
■	Windowed package option for prototyping
■	Low-cost OTP (one-time programmable) package for high-volume applications
■	CMOS for low power consumption
■	User-configurable to interface with any 8- or 16-bit microcontroller
—	Programmable address decoder (PAD)
—	Programmable control signals
—	Programmable polarity
—	Built-in address latches
■	Port expansion/reconstruction of up to 16 I/O Lines
—	Individually configurable as output or input
■	Highly configurable, many operational modes
—	Multiplexed or non-multiplexed address/data buses
—	Selectable 8- or 16-bit bus width
—	Power-down
—	Address inputs can be latched or transparent
—	Latched low-order address byte available as output
■	High-density UV EPROM
—	256K bits configurable as 32K × 8 or 16K × 16
—	Divided into eight equal mappable blocks
—	EPROM block resolution of 4K bytes or 2K words
—	EPROM: Up to 120 ns access time (including PAD decoding time)
■	Static RAM
—	16K bits configurable as 2K × 8 or as 1K × 16
—	SRAM: Up to 120 ns access time (including PAD decoding time)
■	Addressable range
—	1 Mbyte or 0.5 Mword
■	Low-power TTL-compatible CMOS device

into a power-down mode similar to the IDLE mode of the HPC™ by asserting the  $\overline{CS}$  (chip select input) pin prior to the IDLE period. This electronic and functional similarity creates the foundation for designing the system so that the two chips operate as a unit during entire deployments.

The assignable latches and address/data transceivers on board the 301 allow its control circuitry to establish the configurational combinations necessary to best use the host processor (WSI 1990b). In ARMS, the microcontroller is connected to the PLD using a 16-bit multiplexed address/data bus. This arrangement gets maximum performance out of the direct 16-line bus between the two chips while negating any other parallel connections to it that could compromise speed and noise immunity by introducing extra inductive and/or capacitive loads. The other configurational settings are listed in Table 12, along with brief descriptions of how they direct the behavior of the 301 as used in the ARMS package.

The PAD of the 301 also facilitates the mapping of the eight blocks of EPROM, each into any available area of the HPC™'s address space. The memory map of the available HPC16004 locations is shown in Table 13, noting that this use of the ROMless version of the microcontroller opens up a large area for use by the 301's EPROM, which holds the ARMS operational software routines. The 16000's reset vector address must be between F000 and FFFF, so the chosen operational program in the EPROM is mapped starting at F000 with that location as the reset vector address. This, combined with

**Table 12**  
**PAD Configurations**

Configuration Bit Name	Assigned Value	Description
CDATA	1	16-bit data bus
CADDRDAT	1	Multiplexed address/data
CRRWR	1	RD and WR mode
CA19/ $\overline{\text{CS}}$	0	Power down enabled for IDLE; power drain of 50 mA
CALE	1	Address latch enable - high polarity
CRESET	0	Reset - low polarity
$\overline{\text{COMB/SEP}}$	0	Combined address space for RAM & EPROM
CPAF2	0	Port A is I/O port
CPAF1	00H	Port A is I/O
CPBF	FFH	Port B is I/O
CPCF	11	Port C chip select decodes 8-channel A/D
CPACOD	00H	CMOS I/O buffer for port A
CPBCOD	00H	CMOS I/O buffer for port B
CADDHLT	X	A16-A19 transparent - not used
CSECURITY	0	For development, off; if released, on

<b>Table 13 16000/301 Memory Map</b>		
FFFF:FFFE ⋮ F001:F000	Operational EPROM PSD 301	USER MEMORY
EFFE:EFFE ⋮ C001:C000	Reserve EPROM PSD 301	USER MEMORY
BFFF:BFFE ⋮ 5001:5000	External Expansion Memory	USER MEMORY
4FFF:4FFE ⋮ 3001:3000	Reserved	HPC™ Development Board Monitor
2FFF:2FFE ⋮ 0701:0700	External Expansion Memory	USER MEMORY
06FF:06FE ⋮ 0301:0300	PSD 301 SRAM	USER MEMORY
02FF:02FE ⋮ 0201:0200	On-Chip RAM HPC 16004 (512-byte version)	USER RAM
01FF:01FE ⋮ 01C1:01C0	On-Chip RAM HPC 16000	USER RAM
00BF:00BE ⋮ 0001:0000	On-Chip RAM HPC 16000	USER RAM

the PAD's ability to also map I/O ports and configure chip select outputs, allows the CPU to boot up at the proper location with the necessary combinations of control and I/O lines to run each different routine effectively. The same flexibility exists in mapping the static RAM locations, with corresponding control signals and I/O to implement the many different data manipulation functions available within the HPC™ architecture.

### Port expansion

The pin-by-pin assignability of the ports as chip selects or other I/O provides direct access from the digitization hardware (used to decode the high frequency return signals from the acoustic instruments) directly into RAM locations without branching off the main address/data bus. This reconstructive port expansion not only allows running of a wider variety of non-interruptive, high-speed reading algorithms, but also frees up other ports on both the microcontroller and the PLD for more efficient combinational clustering of external components, such as gain control D/A converters and intelligent power supply modules. Combined with the numerous timer outputs of the HPC™, this

permits a large variety of intelligent triggering/switching of external devices and signal conditioning circuitry, using a minimum of additional components and keeping the crucial chip overhead and power consumption low. The use of an 8-channel CMOS A/D converter controlled by the chip select outputs allows the entire control circuit to draw currents in the milliamperere range. Since this entire control circuit of ARMS is roughly the size of a pack of cigarettes, all chips and their passive components leave room to spare on a 4-1/2-in. by 4-in. pressure-container-sized circuit board. All detailed electronic schematics and board layouts are included in Appendices A and B.

## **Analog/Digital Conversion**

The microcontroller and its PLD are so well optimized in both size and power drain that similar economy in the rest of the ARMS control circuit is essential to prevent the compromise of the enhanced performance. Their supporting circuitry must also provide the same multifunctional yet micropowerful attributes. Many analog-to-digital converters (ADC's) have specifications that fulfill the general requirements, but again, one device in particular has design features that make it a perfect match for the ARMS package.

### **Design**

All of the information measured by ARMS is in analog form. After preliminary signal conditioning to boost the individual instruments' outputs into the appropriate voltage range, these signals must be converted into digital data for transfer and storage onto both solid-state and magnetic media. To avoid the peculiarities as well as the redundancy of using individual ADC's for each instrument, a single device converts all outputs. This also saves board space and lowers power consumption.

The Maxim Integrated Products MAX 158 (Maxim Integrated Products 1988) is a complete eight-channel data conversion system (Figure 17). Its analog signal inputs are fed through separate track/holds into an eight-channel multiplexer. These and a precision external reference circuit are all contained on chip, thus eliminating all but the most specific components upstream and requiring only two capacitors to complete the chosen reference configuration (Figure 18).

At the interface between the ADC and the microcontroller/PLD pair, the A/D converter appears as a memory location or input port. Thus, no other logic is required, and the digital data outputs connect directly to one of the PLD's multipurpose address/data ports through internally latched tristate buffers. The input channel selection of the MAX 158 is also supplied directly from another of the PLD's ports configured as a 3-bit coded chip select (Table 14).

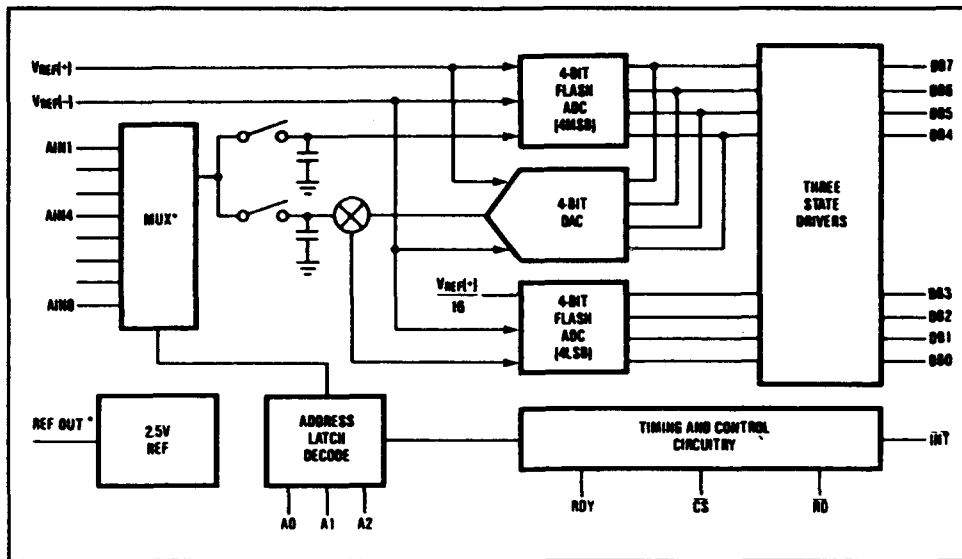

Figure 17. MAX 158 block diagram

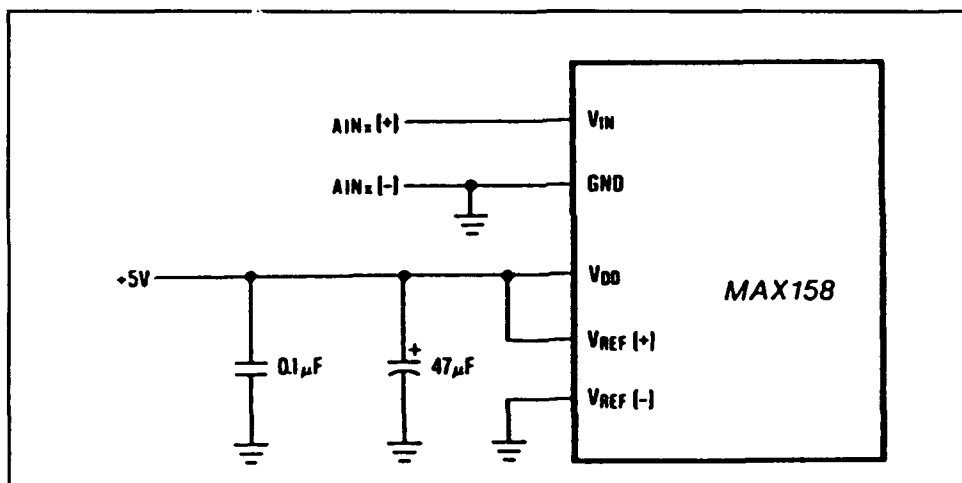

Figure 18. MAX 158 reference circuit

CS10	CS9	CS8	Analog Input Channel
0	0	0	CH1
0	0	1	CH2
0	1	0	CH3
0	1	1	CH4
1	0	0	CH5
1	0	1	CH6
1	1	0	CH7
1	1	1	CH8



The CMOS architecture of the MAX 158 permits direct connection of all pins to those of the HPC 16000 and the PSD 301. The associated +5-VDC supply and logic levels and low power requirements are also comparable, allowing the three chips to function as a completely self-contained unit. With the microcontroller, PLD, ADC, and their passive components on one circuit board, the entire board can be switched on and off independently of the other ARMS circuitry or may be completely removed for testing or installation into another compatible circuit board chassis.

## **Controller Board**

### **Board layout**

The microcontroller, PLD, and ADC are packaged in 64-pin PGA (pin grid array), 44-pin PLCC, and 28-pin DIP (dual in-line plastic package), respectively. The chips are physically installed in mating sockets. The sockets are wired and soldered into place on the controller circuit board. All electronic connections are made before the chips are inserted. This common practice prevents catastrophic static damage during the wiring process, as well as avoiding the conduction of soldering heat through the pins into the delicate IC itself. Prewiring also allows unlimited testing of the wire connections and passive components prior to adding the chips, thus possibly preventing damage to the latter at power up.

The three chip sockets are arranged to take the best possible advantage of the individual pin assignments and their positioning relative to physical termination of each conductor (Figure 20). The microcontroller and PLD are centered on the 4-1/2- by 4-in. board surrounded by the 20-MHz crystal, capacitors, and resistors. The ADC is located between the PLD and the edge connector, so that all connections to it from the signal conditioning board through the edge connector are kept as short as possible to minimize system noise.

### **Connectors/components**

The BASS carriage employs 35-pin Elco-style edge connectors as the units of the chassis backplane (or motherboard). Wired together, they carry signals and supply voltages between individual circuit boards. These connectors provide an extremely secure footing and good constant electrical contact between the pins and captive receptacles. They are designed specifically for printed circuit boards, although they sacrifice some of the accessibility to the connector and lower part of the circuit board itself. For the ARMS circuit boards, a more conventional 44-pin double-fingered slot is employed for added access during field inspection and repair. The circuit boards are double secured by a pair of lateral clamps, which restrict movement even in violent buffetings.

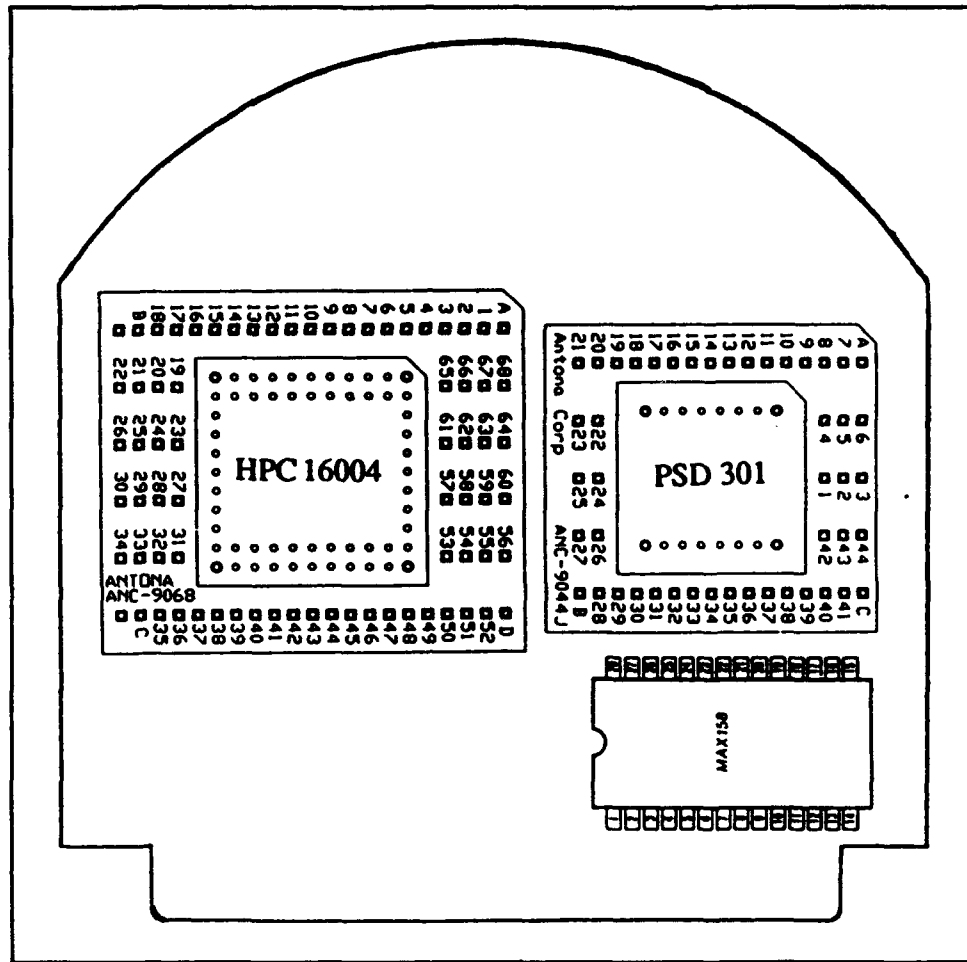

Figure 20. Controller board layout

The sockets and passive components are also secured firmly on the individual boards. During testing deployments, some wire wrap (WW) sockets are used to allow changing configurations of pin hookups and adding special chips in certain specific applications. All components not equipped with WW posts, however, are secured tightly to the board and soldered thoroughly, using heat sinks to prevent damage. Wiring and layout diagrams are included in Appendices A and B.

# 7 Signal Conditioning

---

This part addresses the specific signal conditioning requirements of the instruments directly controlled by the ARMS CPU.

## Requirements

The profilometer, pressure transducer, thermistor, compass, inclinometer, and OBS all have analog signal characteristics that require only a minimal amount of pre-conditioning prior to digitization (the BASS and HANDSS serial outputs are preprocessed). The signals are routed to a dedicated signal-conditioning circuit board. Each output is individually buffered and amplified into a standard analog voltage range upstream of the ADC on the controller board. This further exploits the modular board concept, while spatially and electronically isolating the transducers from the control circuitry and providing immunity from noise and surge.

### Profilometer

The profilometer is a self-conditioned unit that performs the entire transformation of the faint 3-MHz echoes into a 0- to 5-VDC representative signal. This output is an analog time series corresponding to the reflected sound intensity from points incrementally distant along the insonified path. These returns must be range-gated into discrete spatial bins prior to digitization on the controller board. The range-gating circuit must also integrate the total reflected signal strength returning from each range bin during the sampling procedure. By using two separate integrators, the complete profile signal can be enumerated. This is crucial to thorough interpretation of total mass transport at the boundary layer site. This format is slightly different from traditional sampling theory, wherein a signal is sampled discretely at a finite number of points, forming an averaged representation of the original. The integrators allow the generation of a bin-averaged input to the ADC. This method permits the ADC to operate at lower frequencies while achieving similar resolution.

Digital interaction is also required between the control circuit and the profilometer, channeled through the signal conditioning board. The length and position of the range bins are software-controlled by precise clocking lines coming directly from the microcontroller. The overall repetition rate of the

trigger and listen sequences for ensemble averaging of the sampled profiles is similarly synchronized. The digital-to-analog converter (DAC) that translates digital gain control information into the appropriate profilometer levels is also mounted on the signal conditioning board so that it, like the other instruments and their dedicated circuitry, may be powered down when not in use.

### **Other Instrumentation**

The other analog instruments in the ARMS ensemble do not require the level of interactive control that the profilometer does. Their signals are close to the working range of the system ADC and most need only protective isolation and buffering before being sampled. The thermistor and compass outputs consist of variable resistances and require simple analog circuits for conversion and amplification into a usable voltage range aboard the signal conditioning board.

## **Specialized Profilometer Circuitry**

### **Keying**

The sampling sequence of the profilometer begins with a 5-V key pulse that triggers the transmitter, which in turn emits a 10- $\mu$ sec-long, 3-MHz tone burst out through the transducer. The key pulse is provided by the microcontroller from one of the timer output ports. This timer pulse is triggered repetitively at precisely spaced intervals under command from the control software program. On the signal conditioning board, the key pulse is buffered through a Schmitt trigger IC as it is sent to the ACP transmitter. This circuit both isolates the profiler from the microcontroller and sharpens the rising edge of the pulse to ensure clean triggering of the device.

### **Signal Integration**

The conditioning of the incoming profilometer signal requires a combination of synchronized switching and rapid integration over small time intervals. These intervals correspond to the length of time it takes for sound to traverse a profile range bin. After each triggering, there is a short delay to eliminate the extreme near-field returning echoes. Then a pair of switched integrators (Figure 21) alternately parcel the signal train into range-bin size increments. The switching of the integrators is clocked by additional timer outputs from the microcontroller running under the same synchronous command sequence beginning with the key pulse. These control lines activate the integrator hold and reset the switches appropriately (Figure 22).

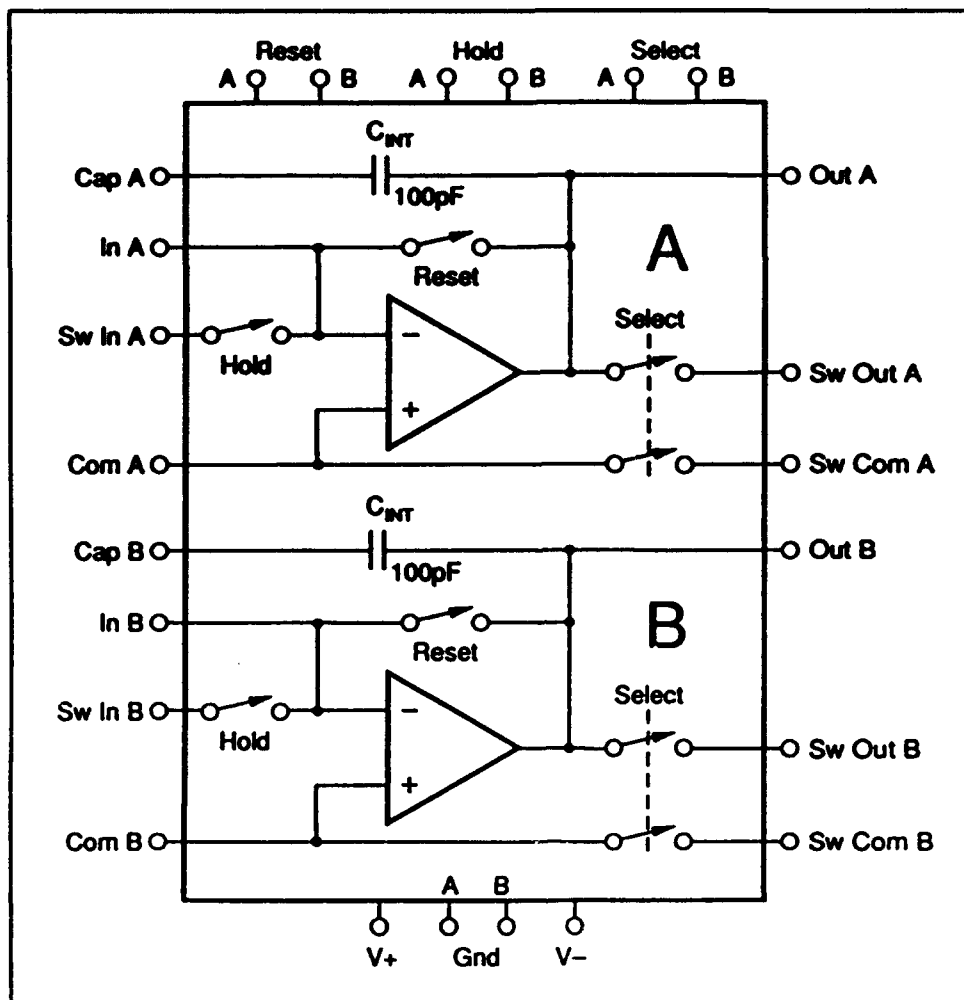

Figure 21. Switched integrator block diagram

This is done with a minimum of hardware connections on the signal conditioning board to heighten isolation from digital noise and stray voltage interference. Additional circuit schematics and timing diagrams are located in Appendices B and C.

### Profile data transfer

The integrated range-gated profile is fed alternately into two separate channels of the system ADC on the microcontroller board. The select switch of each integrator circuit is closed, while the track/hold of the converter captures the signal voltage, also under sequence timing control. The ADC digitizes and sends the binary value directly into controller memory while the select and hold switches are opened, allowing the integrator to be reset to zero. The circuit is now ready to process the next range bin while the other channel is repeating the above procedure. This sequential procedure feeds the profile data into memory in real time, which is fast enough to incorporate the necessary

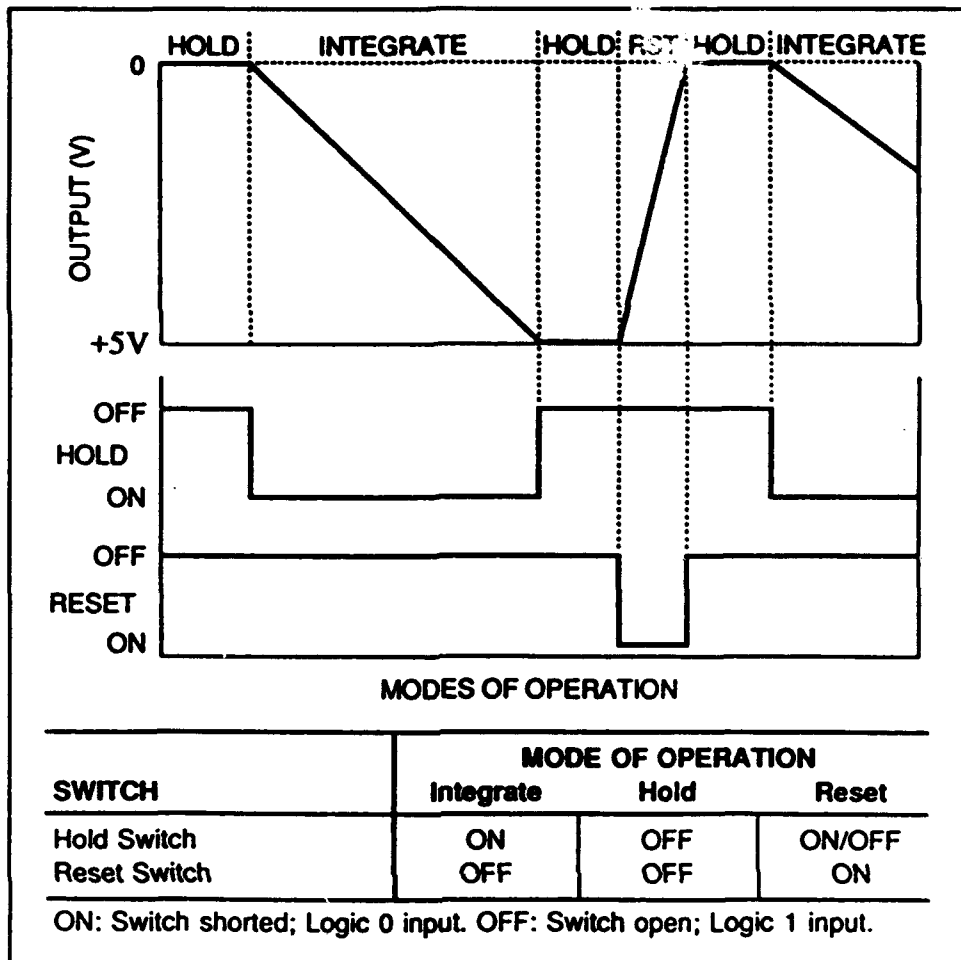

Figure 22. Integrator mode of operation

ensemble averaging computations directly into the timed sampling sequence. At the end of the averaging period, the averaged bin values are available in accessible memory for monitoring and transfer to long-term storage on tape.

### Gain control

The profilometer has an external gain input that is used to control the sensitivity of the device. The gain is regulated by a voltage applied across the inputs ranging from a +15-VDC maximum to a 0-V minimum. Maximum gain is desirable to discern extremely low concentrations and/or small particles. In highly reflective conditions, the gain may be lowered to avoid blooming, (i.e., overwhelming the profile with statistically inconsistent large readings).

The gain voltage is provided by a 4-bit DAC mounted on the signal conditioning board. The DAC may be disabled to supply a fixed gain manually or set by DIP switches at the data inputs or enabled to respond to intelligent

direction from the controller circuitry (Figure 23). The latter scenario relies on running computations on the statistical structure of the individual range bin values by the microcontroller. If the gain is changed, the corrected binary value is fed through a controller data port to the DAC, which in turn sends the adjusted level to the gain input.

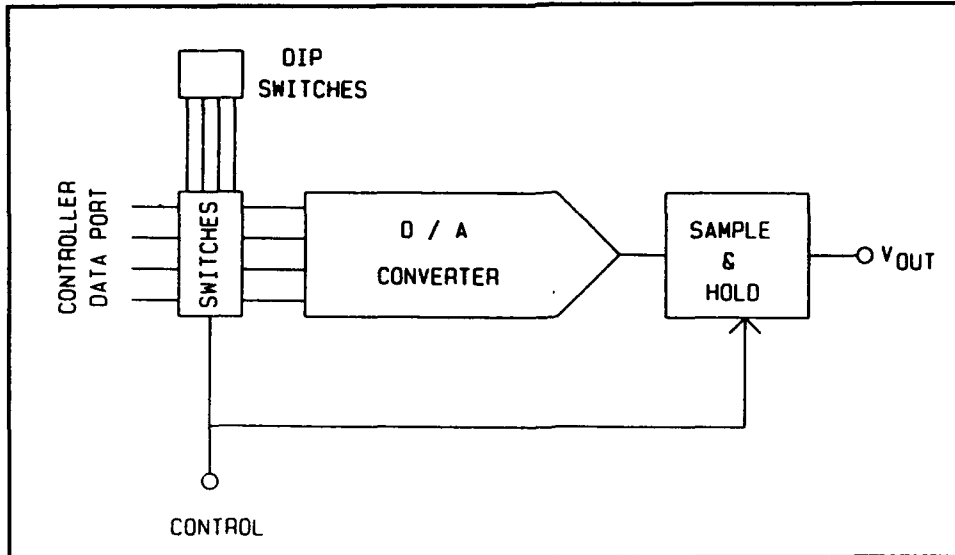

Figure 23. DAC block diagram

## Other Conditioning Circuits

### High-level signals

As mentioned above, the instruments with output voltage levels directly compatible with the 0- to +5-V input range of the ADC require little in the way of signal conditioning. The pressure transducer, inclinometer, transmissometer, and OBS must be impedance matched to their ADC channels. Their signals are therefore buffered through individually isolated unity gain amplifiers on the signal conditioning board. Each signal is sampled sufficiently by the converter track/hold input, eliminating the need to provide that function externally in the preconditioning circuitry. A schematic of the buffer circuit is shown in Figure 24.

### Low level signals

The compass and thermistor are instruments utilizing variable resistance to reflect changes in observed bearing and temperature, respectively. They require simple circuits to convert their resistive values into the working ADC

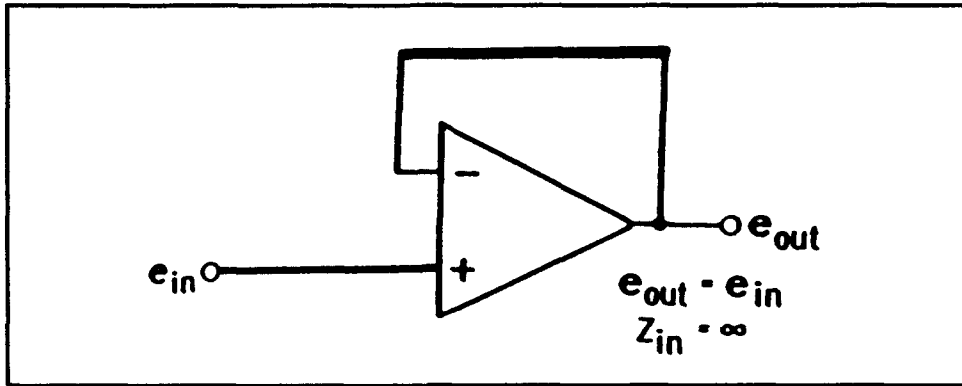

Figure 24. Unity gain amplifier circuit

range prior to sampling and digitizing. Each instrument's resistor circuit is incorporated directly into an individual voltage amplifier (Figure 25) to provide isolated outputs in the 0- to +5-V range (Jung 1978). These outputs feed directly into designated ADC channels, where they are sampled and converted like the other analog voltage signals.

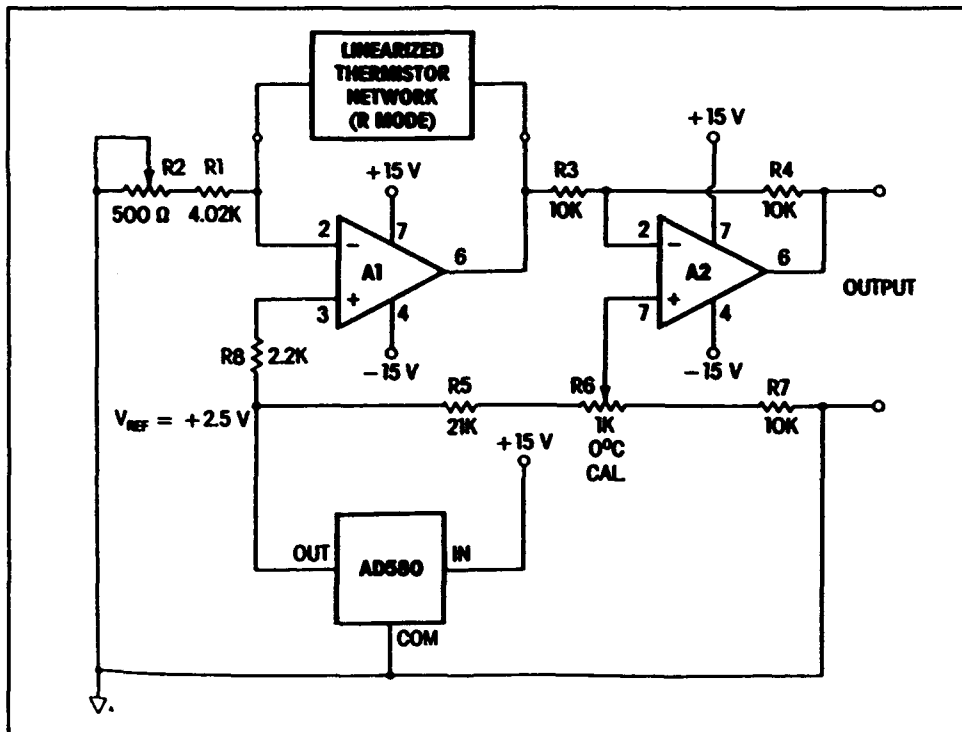

Figure 25. Thermistor conversion circuit

## Signal Conditioning Board

The signal conditioning circuit board is arranged with the individual instrument circuits placed side by side above the edge connector conductors that carry each conditioned output to the ADC. The instrument cables are attached to small connectors at the top end of each circuit. This configuration (Figure 26) prevents crossing of signal lines while providing a distinguishable visual identification of each circuit; this is valuable for testing and repair operations. The complete cabling and schematic diagrams are included in Appendices B and C.

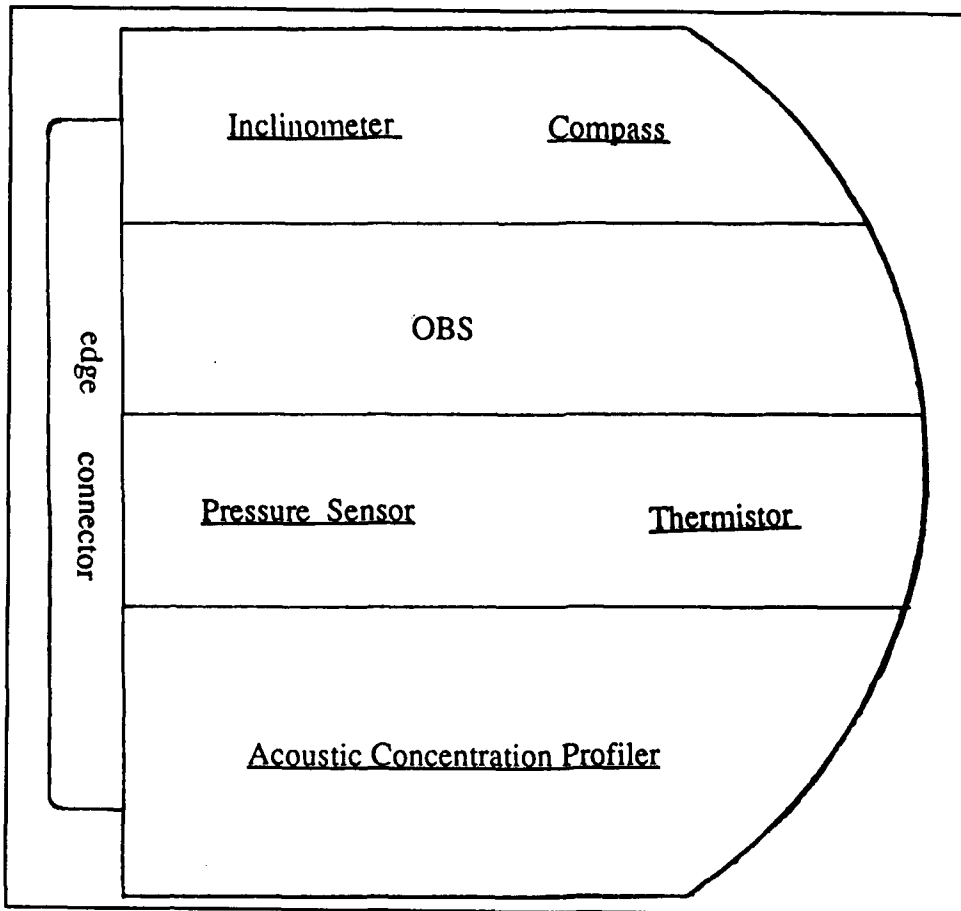

Figure 26. Signal conditioning board layout

# 8 Power Control

---

## Overview

In field deployments, ARMS must rely on a limited battery power supply to run all instruments and supporting circuitry. Many elements that aim to reduce power consumption without sacrificing data acquisition performance are employed in the system's design. Several of these have been discussed, including low voltage field instruments, CMOS circuitry, and hybridized IC chips.

Another way to achieve overall energy efficiency is the intelligent switching of distributed power to each system subdivision. Power control is applied in ARMS over two distinct hierarchies. First, the individual instruments themselves are switched on only when necessary. Recent design advances have provided small distributed power supplies that increase noise immunity by eliminating lengthy conductors carrying "clean" conditioned current. Instead, raw battery power is switched under controller direction to each local DC-DC converter separately (Figure 27). This allows instruments and their signal conditioning circuits to be deactivated in case of component failure, as detected by instrument status checks in a software feedback routine. Error detection thus helps to prevent component damage and excessive battery drain of a shorted connection without using a myriad of fuses, one for each small circuit.

The second distinct hierarchy of switching control is power control of the entire system. There are intervals during continuous data collection when certain measurements, such as tripod bearing and tilt, may be suspended while the others operate. There are also situations when the whole system, except for a timekeeping clock chip, shuts down to stretch battery life as well as tape capacity. Sampling schemes (also under software control) may be temporarily staggered. The system may also sample conditionally by activating only occasionally to measure certain key parameters (e.g., velocities or wave heights) to determine whether they are above assigned threshold values; if so, the entire system begins acquiring data until the observed activity dies off enough to warrant idling down again, or "sleeping," until the next interesting episode. This multiple-scenario flexibility allows ARMS to be programmed for

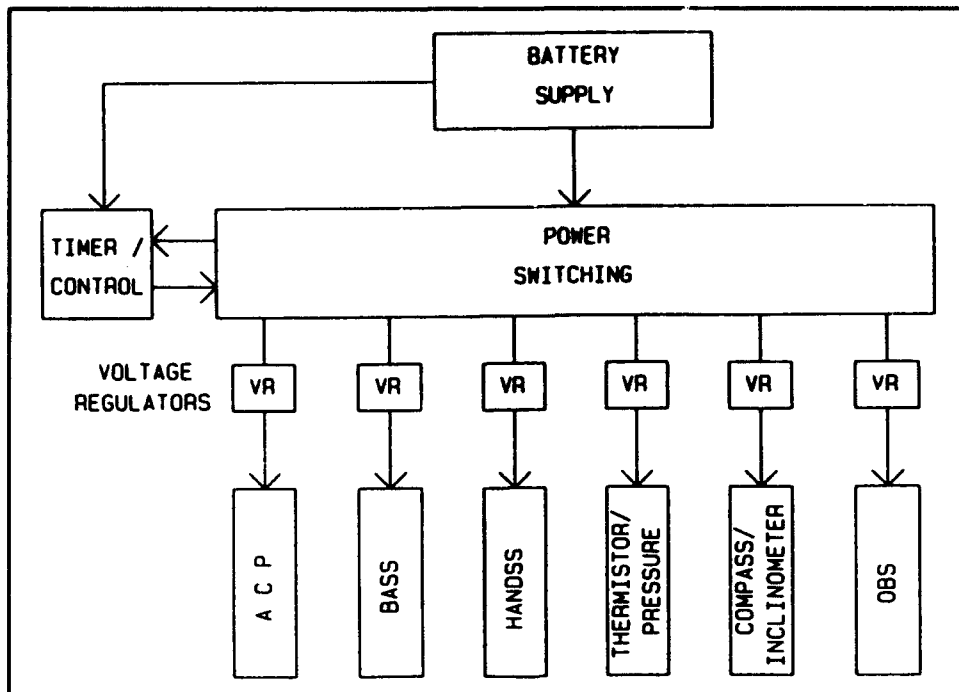

Figure 27. Distributed power diagram

any reasonable custom sampling schedule and is made possible by controlled power switching.

## Switching Schemes

### Acoustic Instruments

The two instruments that output serial data streams, BASS and HANDSS, feed directly into the controller serial interface and require very little power switching hardware. A high-level switch activates them independently when instructed by the controller and they immediately begin transmitting data to their designated receiver ports. This ease of control makes using the velocity readings even more attractive for providing conditional threshold level determination. While the grain size distribution may also be used to trigger the system, its observed response to changing conditions is sometimes more indirect and delayed. The HANDSS device is usually switched on intermittently, because continuous grain size measurements over an entire deployment are rarely necessary.

The profilometer and its signal conditioning circuitry are supplied by a single power switch, so that both operate together. After the controller circuit has been activated, it zeroes the digital outputs to the profilometer, switches the latter on, and initializes all outputs for the beginning of sampling. The data ports to the gain-control DAC are tri-state and are initialized in the high

impedance state, preventing damage from stray voltage spikes. The profilometer and BASS run continuously during data collection, unless a problem is detected by the controller, since their measurements are fundamental to observing the local hydrodynamics.

### **Pressure/temperature**

The pressure and temperature sensors usually run continuously during data collection. Both are activated along with their respective signal conditioning circuits by separate power switches, which allow either to be shut down if necessary. The pressure circuit is a good candidate for a conditional sampling threshold detection trigger since it gives a direct indication of surface wave activity. It may be switched on with other instruments to provide multiple sets of vital readings for inspection and comparison by the conditional software program. Unlike the profilometer, the pressure and temperature circuits do not require digital timing outputs from the controller, so no specific pre-switching initialization is required.

### **Tilt/direction/TSM**

The ancillary devices are seldom used continuously and are switched on only when necessary. The inclinometer and compass and their signal conditioning circuitry are activated by a common power supply switch, because they are usually queried in tandem. The OBS is switched separately, because it may be run continuously with the profilometer or intermittently with the grain size device. These ancillary instruments, which require no control lines once activated, are wired directly into the system ADC.

### **Controller power**

The power supply for the system controller is always enabled; this helps to avoid sporadic interruption during program execution. The controller circuit is placed into an idle mode using programmed criteria fed into a timekeeping IC. When finished with a sampling run, the controller shuts all instrument power switches off and then activates the timekeeping circuit. This timer asserts the appropriate control lines to idle the controller chips and counts down until the next run. When the sleep time has elapsed, the timer awakens the controller and triggers program execution. A small power switch turns the ADC off and on when the controller idles and restarts, respectively. The timing and circuit diagrams are located in Appendices B and C.

## **Power Control Board**

Like the signal conditioning board, the individual power switches are placed side by side on the power control circuit board (Figure 28) to line up with the

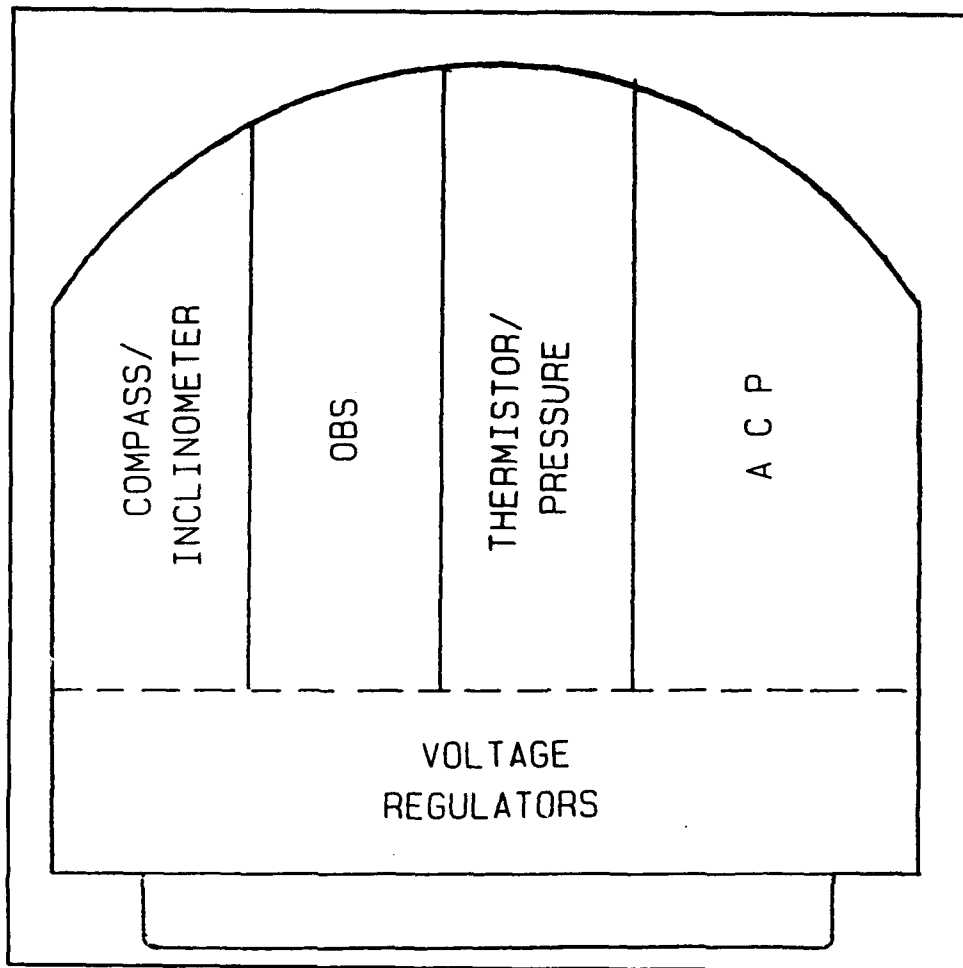

Figure 28. Power board layout

corresponding conditioning circuits on the former. Again, this eliminates crossing of activated power lines and provides visually separated circuits for individual testing and repair. The switches are located near the upper end of the circuit board, above the DC voltage converters which reside next to the edge connector. The supply voltages to the signal conditioning board are routed along the edge connector.

The inputs to the switches are raw +24-VDC battery supply. When the batteries are connected to the ARMS package, the controller initializes itself and then successively activates each power switch and queries the corresponding instrument. Once all instruments are switched on and checked, the controller begins executing the preprogrammed sampling routine, switching itself and the instruments accordingly. As stated above, when the sampling run is over, the controller switches off each instrument and puts itself into idle mode. All electronic schematics and connection diagrams are included in Appendices B and C.

## 9 ARMS Hardware Chassis

---

### Pressure Container

The ARMS and BASS circuitry reside in a common pressure housing supplied with the BASS system. The pressure housing is a cylindrical steel pipe section with milled ends that accept steel end caps. The end caps have internal circumferential O-rings that facilitate placement into the cylinder and seal the container. The caps are secured with external tensioned ring clamps. The pressure container is rated for use at pressures up to 3,000 psi, although the safe working depth range of the entire system is down to 100 ft. For deeper deployments, extra recovery devices must be added to the tripod, which compromise its ability to make the delicate readings it was designed for.

The design of the end cap makes use of two contact surfaces between it and the pressure cylinder itself. The internal "plug" side of the cap is fitted with a circumferential O-ring that forms a seal between it and the internal cylinder wall (Figure 29). A second O-ring is placed loosely in a groove around the inner face of a flange on the outer edge of the end cap that mates flush with the end of the cylinder. When the end cap is clamped into place, the O-ring is captured in its groove between the two machined faces. This provides a secondary seal that serves to isolate the primary inner seal. Pressure container dimensional drawings are found in Appendix A.

### BASS Chassis

The BASS electronics are mounted on printed circuit boards that plug into parallel edge connectors mounted on a metal chassis. The chassis is mounted rigidly to the inside face of the pressure container end cap that is equipped with underwater bulkhead connectors mounted on the external face. The chassis, with circuit boards in place, is aligned with the axis of the pressure cylinder and slid gently in until the end cap lip meets the end of the cylinder.

Four of the bulkhead connectors carry signals to each of the four BASS cages. They are directly connected to four sets of analog receiver and

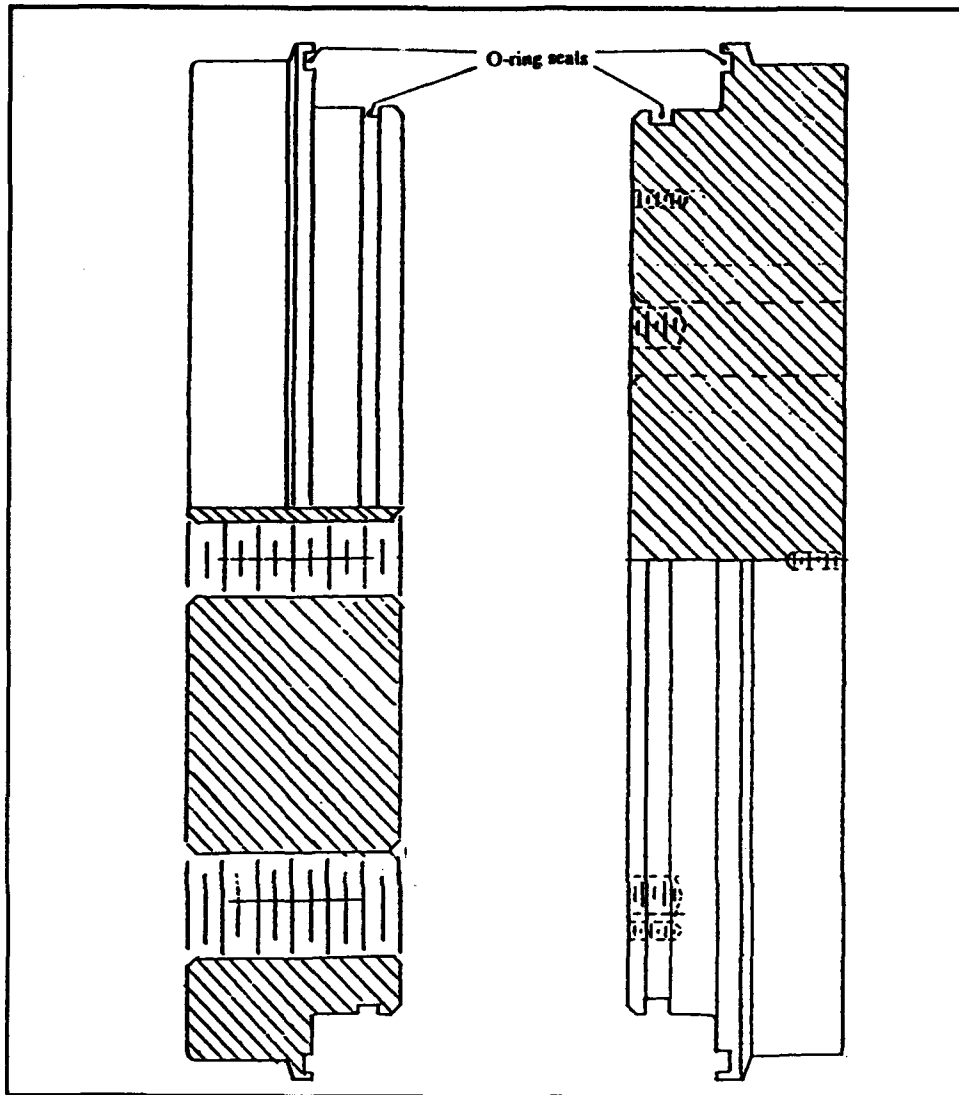

Figure 29. BASS end caps

transmitter circuit boards in the eight edge connector slots closest to the end cap. The coaxial cable connections are shortened and secured to prevent damage and electrical interference. This, however, makes their positioning semi-permanent and it is recommended that the analog boards and connections be removed only if electrical problems occur.

The analog boards are electronically connected to timing and CPU boards with insulated wires that span their edge connectors in parallel fashion. The timing boards process the received signals and, under control of the CPU board, translate them for digitization. The ADC that digitizes the translated signal voltages for serial transmission is on the small Tattletale board piggy-backed to the CPU board. The CPU board is protected by a plate fastened to the internal end of the chassis. Chassis layouts and wiring diagrams and dimensional container information are presented in Appendices A, B, and C.

## **ARMS Chassis**

The ARMS circuitry is housed on circuit boards similar in shape to those of the BASS. They also fit into edge connectors that transfer signals and voltages between boards. The edge connectors are mounted on a chassis that is attached to the inside of the other end cap of the BASS pressure housing. When inserted to the opposite end of the pressure cylinder, the chassis fills the space left by the BASS chassis, with enough room between the two protective chassis end plates to accept excess cable lengths when the container is sealed.

The circuit boards are arranged according to their functions and necessary connections. Closest to the end cap is the controller board, located there to isolate it from the BASS and other ARMS boards. It also requires no connections other than the edge connector itself. Next to it is a serial communications board that houses the receiver and transmitter drivers controlled by the microcontroller UART. The signal conditioning board is next in line with instrument cable connectors along the top edge of the board. The last board, next to the protective end plate of the chassis, is the power switching board, located between BASS and ARMS to provide power to both without running power lines any further than necessary. All associated diagrams are located in Appendices A, B, and C.

## **Internal Connectors**

Several sets of internal cables and connectors transfer non-edge connector signals between circuit boards. One pair of conductors runs from the BASS to the ARMS chassis, one carrying power to the BASS and the other carrying the serial velocity data to the communications circuitry. The rest of the internal cables run from five other bulkhead connectors on the BASS end cap to boards in the ARMS chassis. One carries power and serial data to the tape housing from the power and communications boards, respectively. A second carries signals to and from the profilometer and the power and signal conditioning boards. A third carries tilt and bearing signals and power lines between the compass/inclinometer housing atop the BASS cage array and the ARMS boards. A fourth and fifth transfer power to and signals from the HANDSS and OBS. All internal cabling diagrams are included in Appendix C.

## **External Connectors**

The five bulkhead connectors mentioned above accept the underwater cables that run from the external instruments to the BASS/ARMS pressure housing. Cables run directly between all of the underwater containers except for the tape housing. The cable between ARMS and this housing carries serial data to the tape and power to the ARMS circuitry. The cable also carries additional serial lines in and out of the ARMS package. These are relayed through the tape housing and fed through a separate cable connecting the

system to the operator interface. This connection allows monitoring the data stream into the tape drive as well as interactive control and inspection of the ARMS circuitry, both prior to deployment and while testing is under way. The external battery supply lines are fed through the tape housing in a similar manner. All cabling diagrams and connector drawings are included in Appendices A and B.

# 10 Mass Storage Unit

---

## Streaming Tape Drive

In field deployments, a data-intensive system like ARMS can acquire a large amount of information quickly. Drawing current within the battery-supplied power range while accepting and storing large data sets at high transfer rates is a difficult task. Technologies are advancing in the fields of solid-state memory and disk drives to the point where both are becoming rugged, small, fast, and efficient enough to be considered for use in field environments. For the present, storage versus power versus size considerations point to the streaming tape drive for long-term mass storage of ARMS data.

The Sea Data HCR-660 High Capacity Recorder (Sea Data 1986) is a battery-powered field version of the backup tape storage system common to office computers. The attribute that makes the streaming tape adaptable for field use is the rapid rate of transfer. The tape drive motor only operates when a 128-kilobyte data buffer is full, approximately once every 7 min. The motor switches on, first rewinding the tape to the end of the previous record, then rapidly "streaming" the data onto tape. The motor is then shut off for another 7 min. The intermittent format allows the overall power consumption to be kept reasonably low for the amount of data transferred.

The streaming tape drive records onto 60-Mbyte 1/4-in. tape cartridges in the standard QIC-24 format. Tape and recorder specifications are listed in Table 15. The microprocessor aboard the recorder can be programmed to accept different baud rates of both incoming serial data and operator programming commands. The operational software allows the recorder to be inspected and tested for electronic problems. It is also possible to inspect the content of a tape to trace data gaps and to qualify the ends of records to ensure that data transfers are being completed properly.

**Table 15  
Streaming Tape Drive Specifications**

<b>Power Supply Requirements</b>	
<b>Voltage:</b>	12V min, 20V max (12V to 36V optional)
<b>Current:</b>	Standby: 40 $\mu$ A min, 250 $\mu$ A typ, 1 mA max While acquiring data: 30 mA min, 50 mA max Tape running: 1.8A av, 2.6A max with 15V input, 500 mA (with optional NiCad booster battery)
<b>Energy:</b>	100 mAH (15V battery) per MByte max
<b>Batteries:</b>	Alkaline battery pack, 12V sealed lead-acid battery, or 15V NiCad battery pack
<b>Interface</b>	
<b>Serial:</b>	RS-232 compatible (-5V to 5V or 0 to 5V levels) Baud rates 300 - 38.4k baud; 7 or 8 data bits; 1 or 2 stop bits; even, odd or no parity
<b>Data Formats</b>	ASCII, ASCII encoded hex, 8-bit binary, formatted ASCII-encoded hex
<b>Capacity</b>	1 MByte per 10 feet of tape
<b>Media</b>	Data Electronics 450 ft or 555 ft tape certified for 10,000 fpi, or any 0.25 in. cartridge certified for 10,000 fpi
<b>Average Rates</b>	
<b>Write:</b>	3 kBytes/sec (max) using serial interface
<b>Read:</b>	2.8 kBytes/sec (average) using serial interface Equivalently, 6 min/MByte approx (higher rates using parallel interface)
<b>Design Details</b>	
<b>Tape Drive:</b>	Tandberg basic tape drive (QIC-44) with Sea Data's modifications
<b>Formatter:</b>	Tandberg QIC-24/QIC-02 with Sea Data's modifications
<b>Controller:</b>	Sea Data QB-85 low-power microprocessor controlled
<b>Buffer:</b>	128 kByte standard, 256 kByte optional
<b>I/O Buffer:</b>	16 kByte, serial I/O interrupt driven
<b>Mechanical (HCR-660M modular version)</b>	
<b>Dimensions:</b>	6.20 in. (15.75 mm) diameter, 15 in. (38.10 mm) high
<b>Weight:</b>	10.6 lb (4.6 kg)
<b>Vibration:</b>	At 60-500Hz, acceleration 1 G (drive in operation)
<b>Impact:</b>	50 mm free drop
<b>Environmental</b>	
<b>Temperature:</b>	-5°C to 40°C (drive in operation), with no more than 6°C variation per hour
<b>Humidity:</b>	15 to 90% RH (drive in operation)
<b>Pressure:</b>	70 to 106kPa (maximum altitude 3km, 10,000 ft)
<b>Audible Noise:</b>	45 dBA

## **Isolated Battery Supply**

When the streaming tape drive is actually rewinding and transferring data onto tape, it draws over 1 A of current from a +18-V battery supply. Although this occurs only for a few seconds, it is enough to draw down the voltage level of the batteries momentarily, even when using a nickel-cadmium booster battery pack designed to trim the peak off the power demand curve. In addition, stray motor noise leaks from the tape drive into the power supply lines. Therefore, a separate battery supply is provided for the tape recorder. Aside from preventing detrimental voltage sags and noise propagation, the separation of the two power sources also extends the effective life of both, allowing longer full-power deployments. If problems arise in one of the two power circuits, a separated scheme permits longer data collection time before a failure and prevents damage to the other system.

## **Pressure Housing**

The streaming tape drive is encased in its own underwater pressure housing. The separate housing reinforces the modular concept, keeping all of the ARMS tripod components small, thus reducing obstructions to the local flow field. The tape housing contains twenty 6-V lead-acid gelled electrolyte batteries, providing power to fill a 60-Mbyte tape over any time duration of deployment. The modular design allows quick disconnections in the field for easy changing of the tape before redeploying the system.

As mentioned above, the tape housing has external bulkhead connectors for incoming serial data from ARMS, the operator interface, and the main battery supply for the system. Grouping these connectors at the tape container allows the operator to check both battery supplies, tape drive performance, and ARMS data stream status from a common location. Schematic, connector, and cable diagrams are provided in Appendices A, B, and C.

# 11 Battery Pack

---

## Power Requirements

The ARMS circuitry requires only a single +24-VDC voltage source to supply all of its distributed power converters. Depending on how the system is programmed, it will require different amounts of reserve power to fulfill the entire deployment mission. For continuous sampling, the battery pack must supply full power until the deployment is over. Over staggered or conditional sampling periods, the power consumption will vary from full drain to a small standby level. For both sampling scenarios, rechargeable sealed lead-acid batteries provide the most workable field solution toward the optimization of battery size versus capacity.

If a tape is used to store ARMS data, its 60-Mbyte length determines the total elapsed time of data sampling that can be accomplished. Under the normal range of data acquisition rates with the full complement of ARMS instruments, the tape will be full in 3-5 days. A staggered sampling scheme can collect the same amount of data over a longer deployment with idle periods. A battery pack that has just enough power to supply ARMS for a complete continuous run, however, will not have enough capacity to provide a complete staggered deployment over a longer time period. This is due to the extra standby capacity required for the idle intervals between sampling. The idled system draws only a tiny fraction of the operating power, allowing the batteries to recover slightly, but there is still a net power drain. Depending on the schedule of intermittent sampling, including the frequency with which instruments are activated to check for conditional thresholds, capacity of the batteries must be upgraded accordingly.

## Battery Options

The basic power cell for use with ARMS is a rechargeable sealed +12-VDC lead-acid storage battery. Two of these units, in series, produce the +24 V needed to run the system. If the batteries are pre-built inside plastic under-water housings, they may be directly mounted under the top of the ARMS tripod. This allows quick turnaround of the system between deployments,

since only the underwater cables need to be disconnected. After a fresh pair of batteries is mounted and the tape is changed, the cables are reconnected and the tripod may be immediately returned to the seafloor. This can feasibly be done quickly onsite.

For slightly longer intermittent deployments, a second pair of +12-V batteries can be added to provide additional power capacity. These are connected to the first pair in parallel and switched inside the tape housing, using a diode for reverse current protection. This nearly doubles the reserve capacity, minus a small percentage due to reduced efficiency and diode voltage drop.

To provide power over months-long deployments, two options are possible. First, multiple pairs of +12-V batteries may be daisy-chained together with level-sensitive switches that change battery packs automatically when a pack has dropped below a usable level. A second option is to use an intermediate DC converter that has a much wider input range upstream of the ARMS power circuitry. This may be connected to higher-voltage batteries that will drain over a longer time period before approaching the lower voltage limit of the intermediate converter. Though slightly less efficient due to increased heat dissipation, these recently available wide-range converters may allow enough extra capacity to make certain longer-term deployment schedules possible. Battery configurations and power circuit schematics are included in Appendix B.

# References

---

- Aanderaa Instruments. (1972). "Model 1248 potentiometric compass," Technical Note No. 148, Nesttun, Norway.
- Bedford, K., and Abdelrhman, M. (1987). "Analytical and experimental studies of the benthic boundary layer and their applicability to the near-bottom transport in Lake Erie," *Journal of Great Lakes Research* 13, 628-48.
- Bedford, K.W., Wai, O.W., Velissariou, P., Van Evra, R.E., and Lee, J. (1991). "Fine material entrainment and flux at a shallow-water dredged mound." *Marine Technology Society conference proceedings*, Vol 1, 260-64.
- D&A Instrument Company. (1991). "OBS® suspended solids & turbidity monitors-instruments data brochure," Port Townsend, WA.
- Edo Corporation. (1981). "Instruction manual for the model 563 3MHz depth sounder," Report No. 13331, Salt Lake City, UT.
- Jung, W. G. (1978). *IC converter cookbook*. Howard W. Sams and Co., Inc., Indianapolis, IN, 533.
- Libicki, C. M., Bedford, K. W., and Lynch, J. F. (1989). "The interpretation and evaluation of a 3 MHz acoustic backscatter device for measuring benthic boundary layer sediment dynamics," *Journal of the Acoustical Society of America* 85(4), 1501-15.
- Lucas Sensing Systems. (1990). "Accustar II dual axis clinometer data sheet," Phoenix, AZ.
- Maxim Integrated Products. (1988). "Max 158, CMOS high speed 8-bit A/D converter with multiplexer and reference datasheet," Sunnyvale, CA.
- National Semiconductor Corporation. (1987). "HPC™ HPC16083/HPC160431/HPC16003 user's manual," NSC Publication Number 424410-897-001A, Santa Clara, CA.
- Onset Computer Corporation. (1989). "Tattletale® single board loggers/controllers with TT BASIC operating system," North Falmouth, MA.

- Sea Data Corporation. (1986). "HCR-660, HCR-1760 reference manual: Preliminary draft rev. 2.00," Newton, MA.
- US Army Corps of Engineers. (1988). "The Dredging Research Program," *Dredging Research*, Vol DRP-88-1, U.S. Army Engineer Waterways Experiment Station, Vicksburg, MS.
- Wika Instrument Corporation. (1989). "ST-420 pressure transducer data sheet," No. 9734635, Lawrenceville, GA.
- Williams, A. J. (1990). "BASS instructions," Oceanographic Instrument Systems, Woods Hole, MA.
- WSI. (1990a). "Programmable system™ device, PSD301, user configurable peripheral with memory datasheet," Fremont, CA.
- \_\_\_\_\_. (1990b). "Programmable system™ device, application note 011, using the PSD301 with microprocessors and microcontrollers," by Chris Jay, Rev 1.31, Fremont, CA.
- YSI. (1977). "Thermilinear® component YSI 44204 data sheet," Item 003490, Yellow Springs, OH.

# **Appendix A**

## **Physical Diagrams**

---

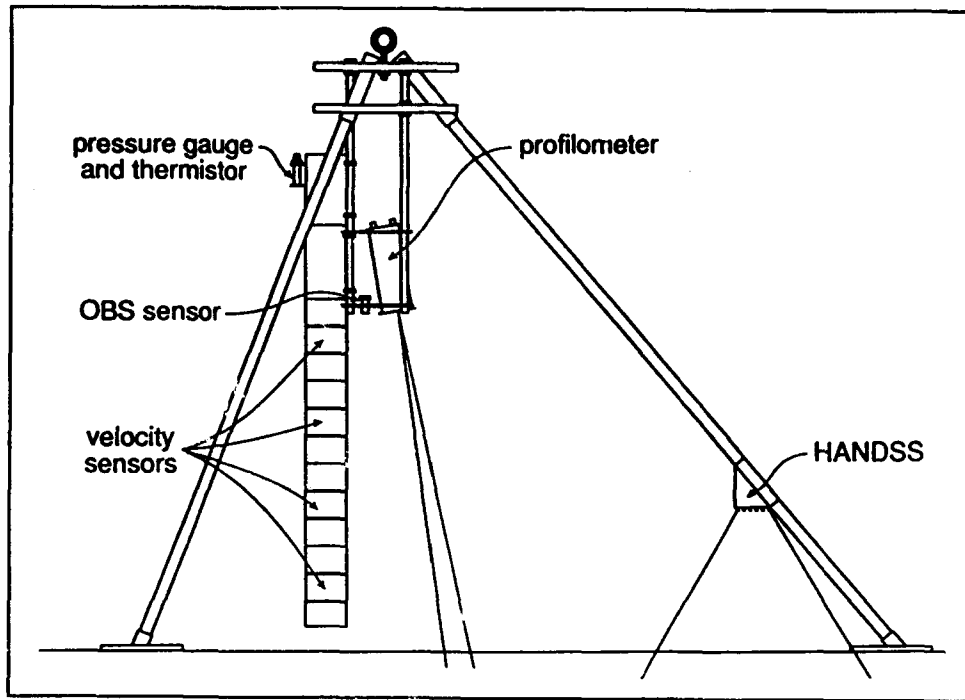

Figure A1. ARMS tripod

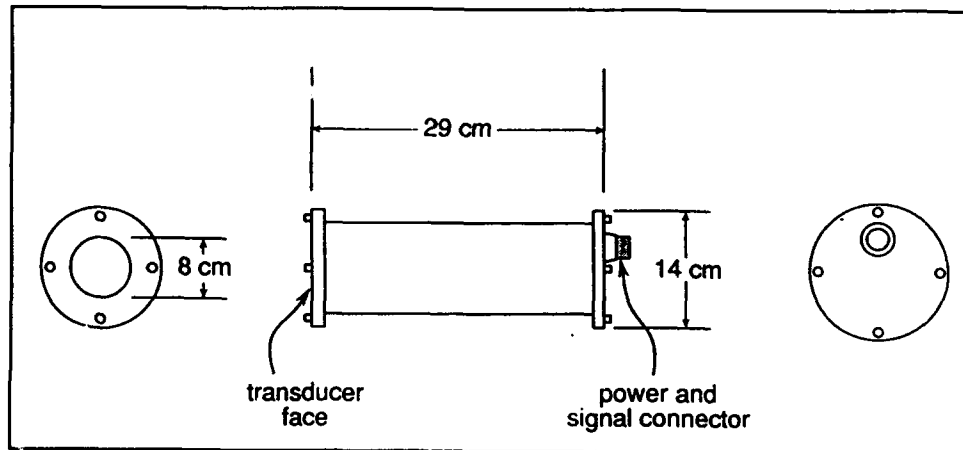

Figure A2. Profilometer

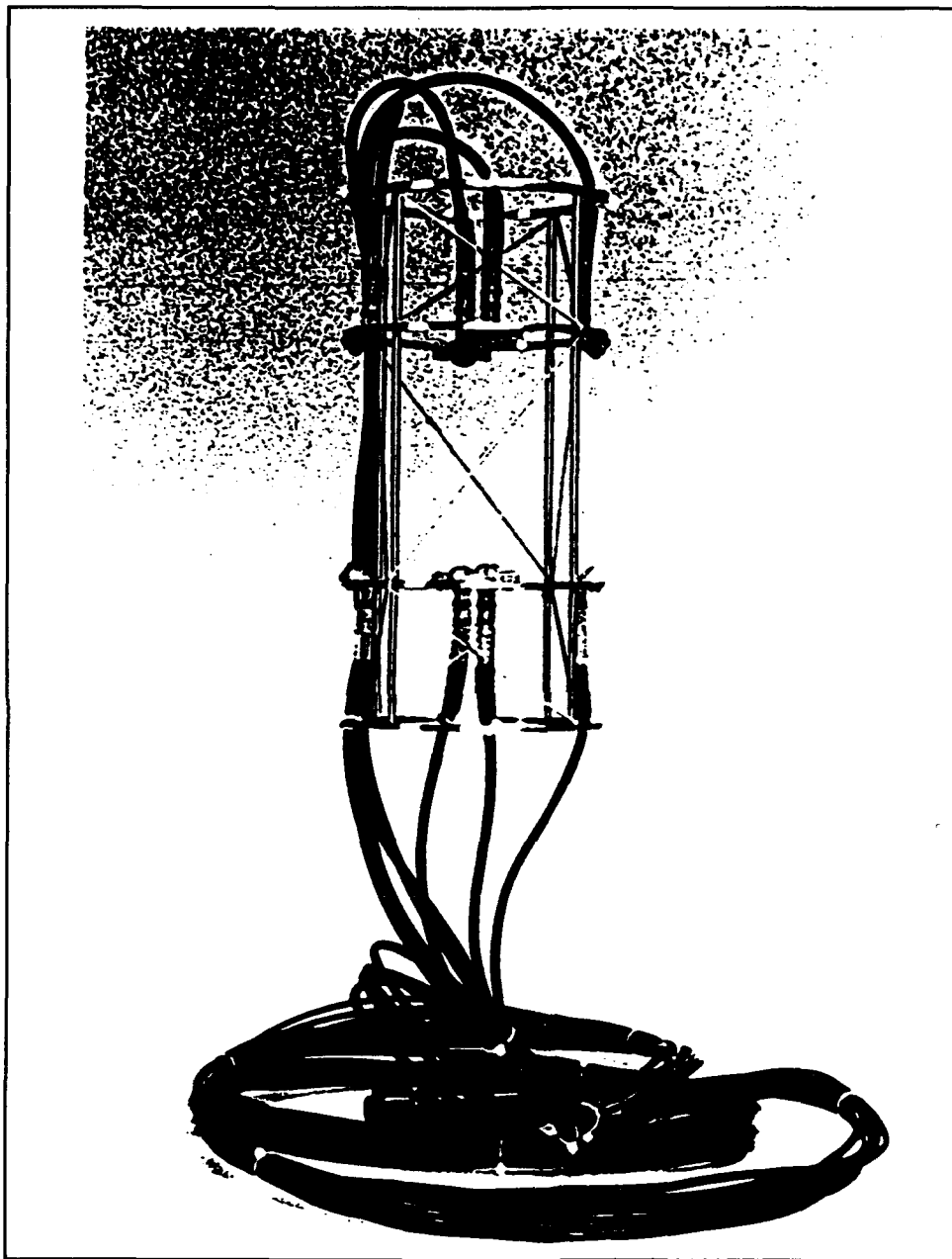

Figure A3. BASS cage

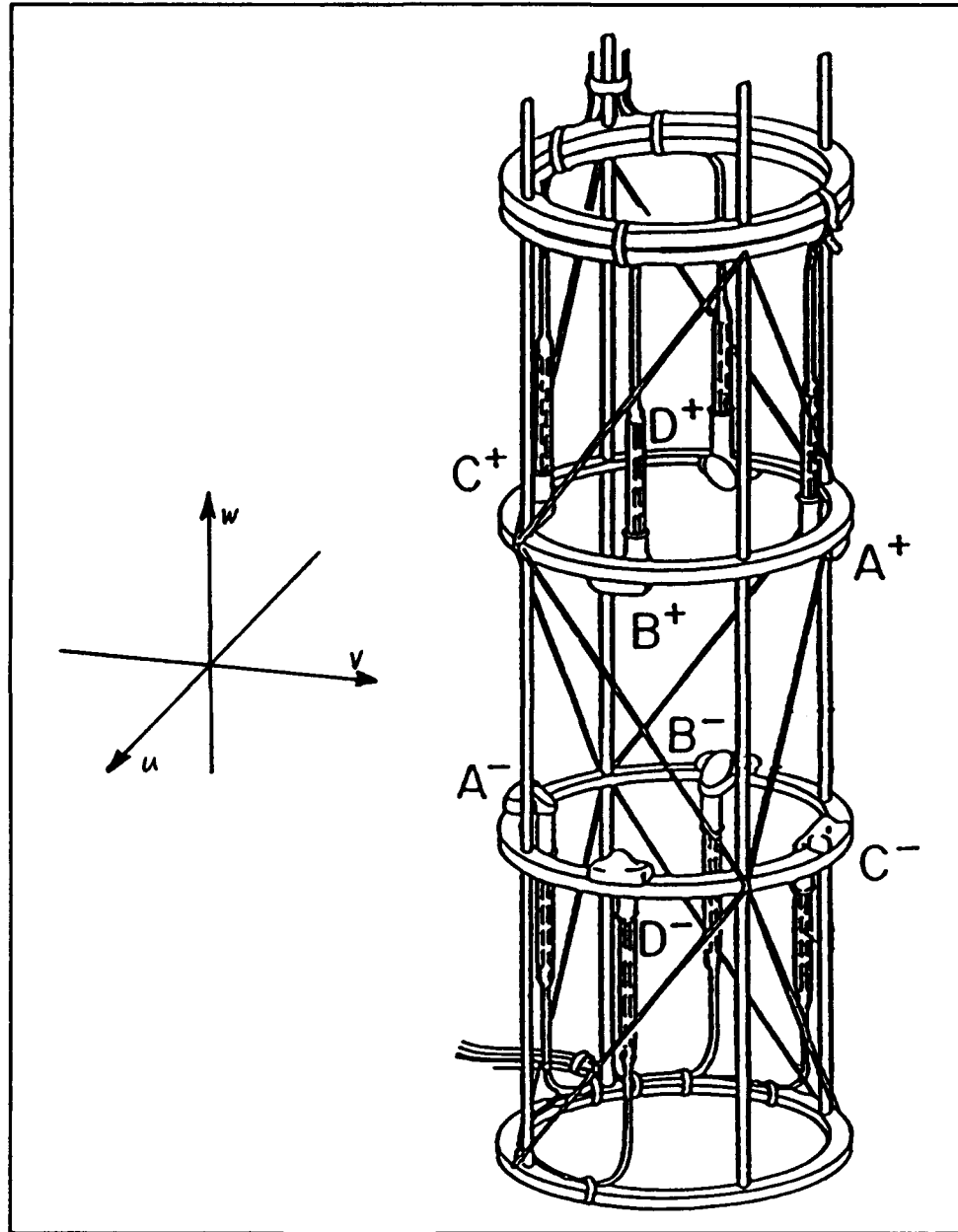

Figure A4. BASS transducer orientation

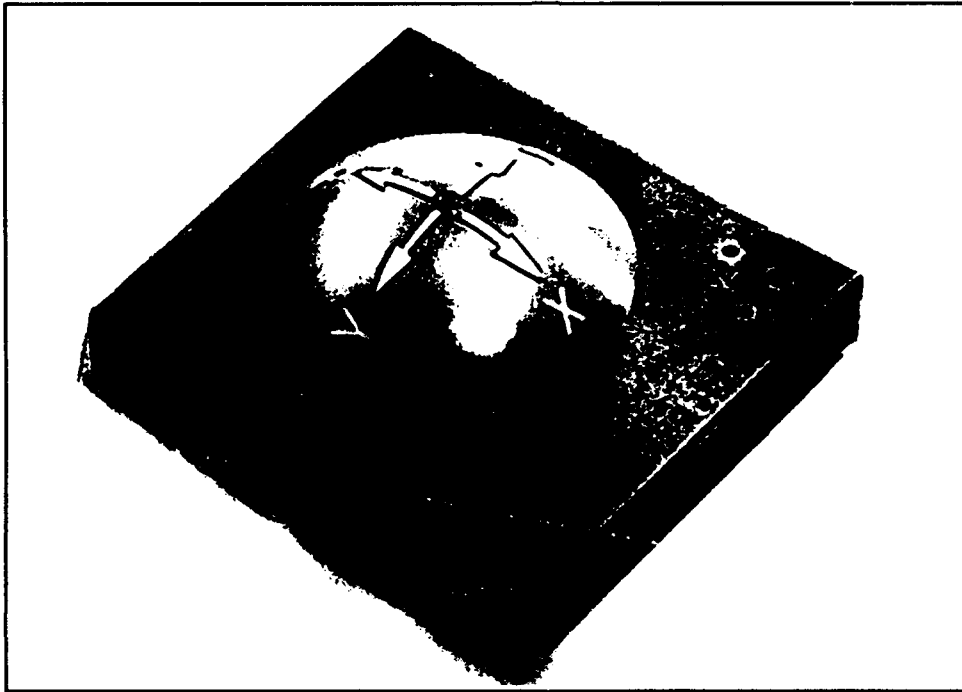

Figure A5. Inclinometer

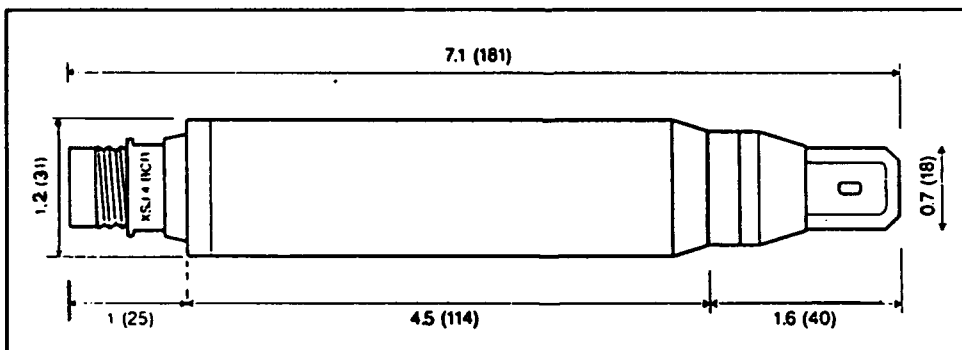

Figure A6. OBS

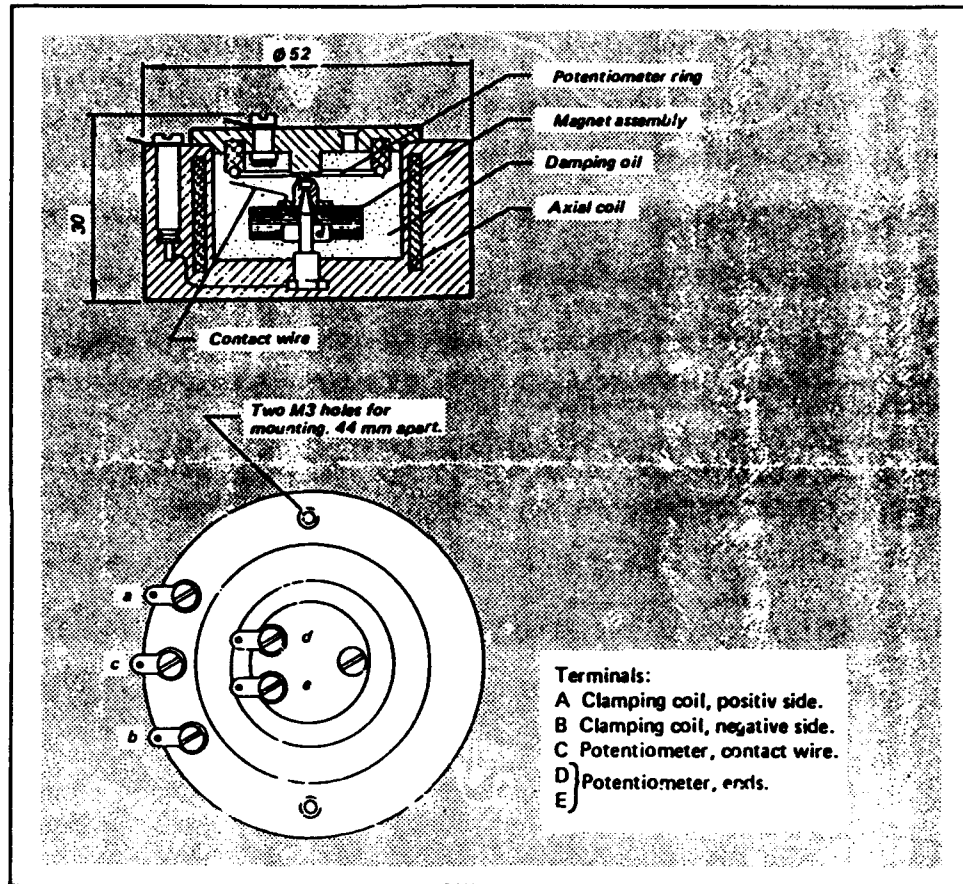

Figure A7. Compass

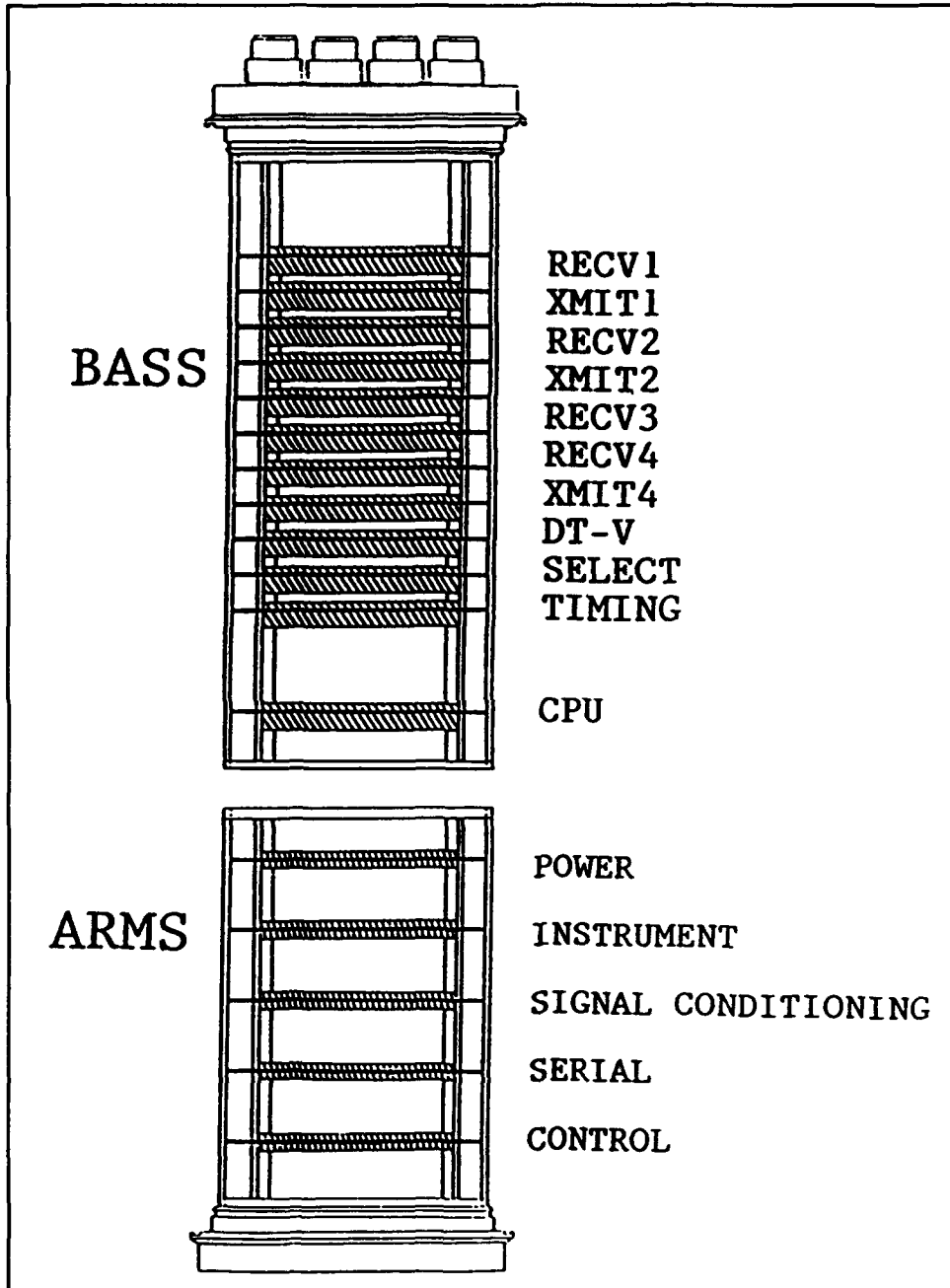

Figure A8. ARMS/BASS circuit chassis

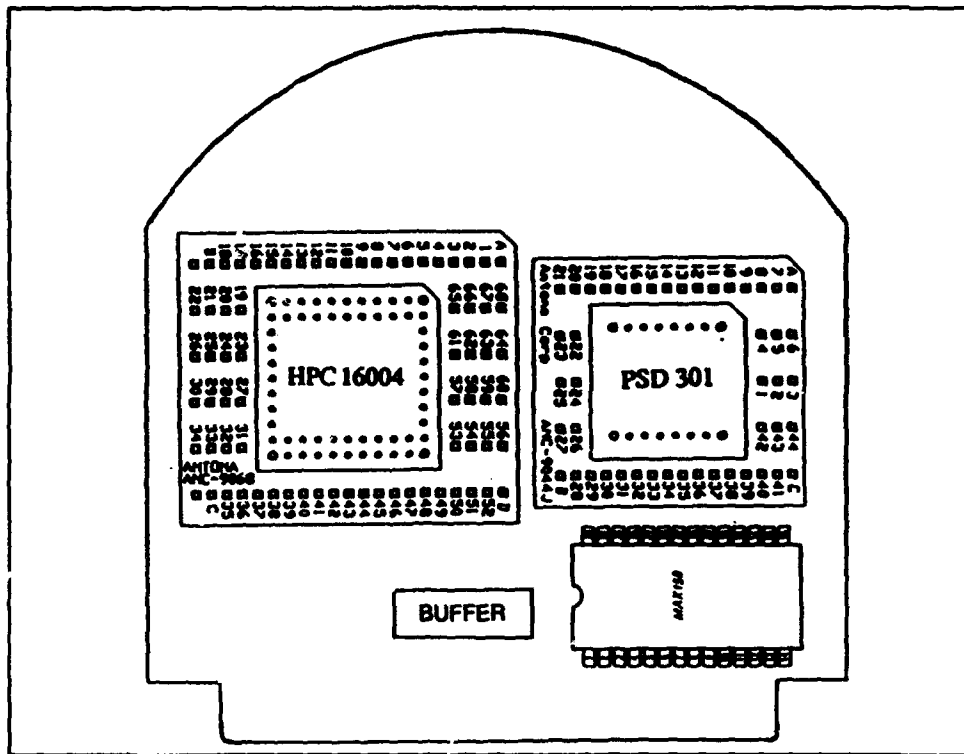

Figure A9. Controller board

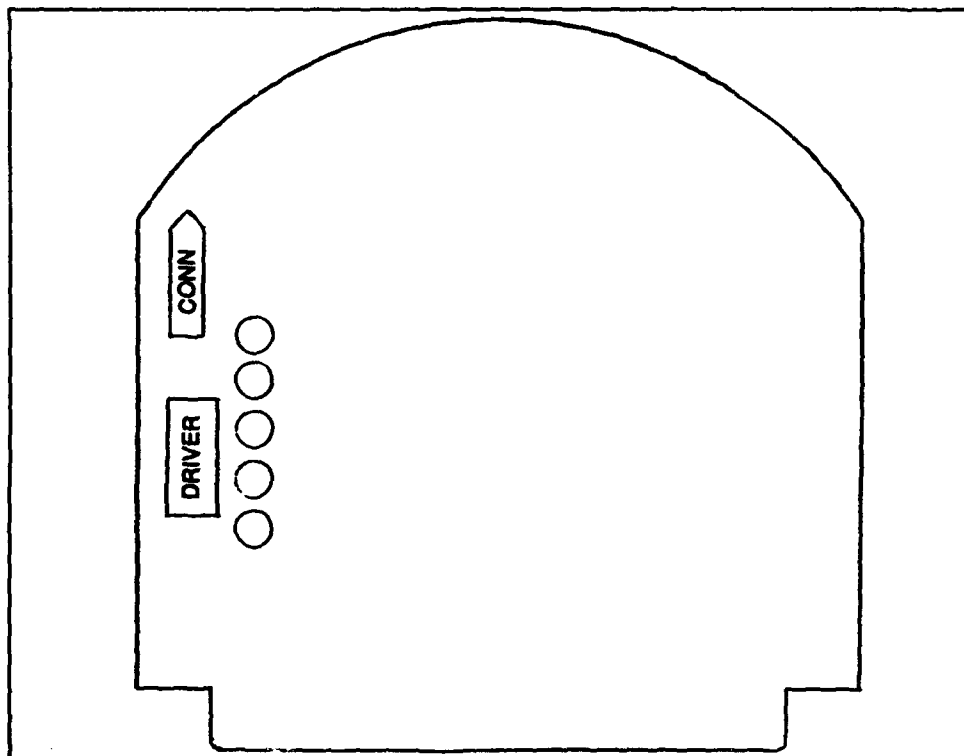

Figure A10. Serial communications board

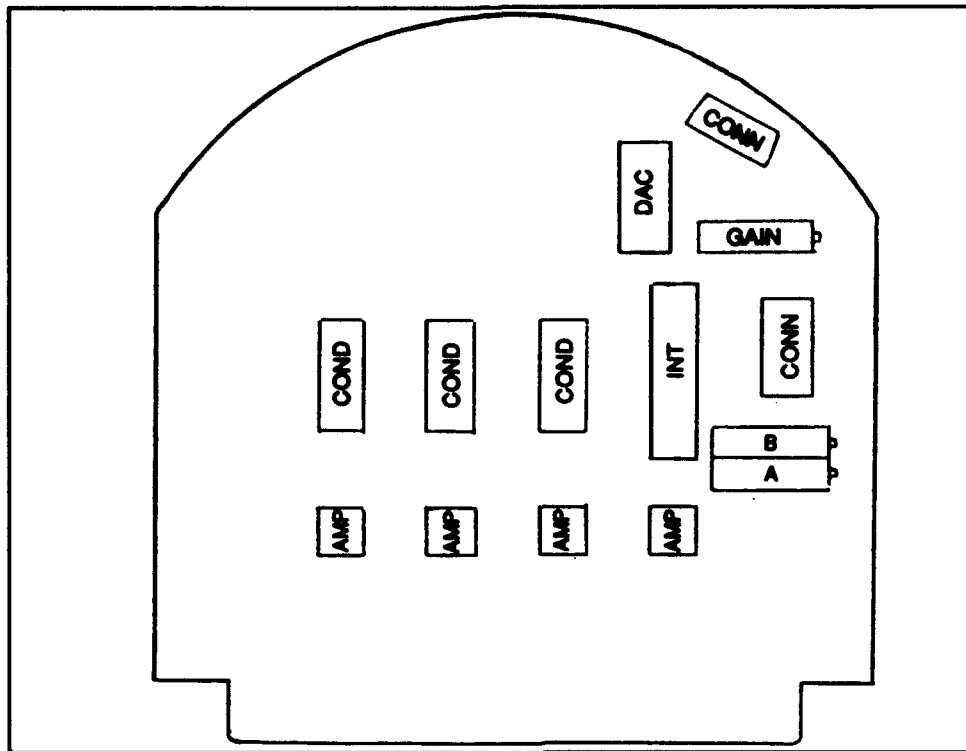

Figure A11. Signal conditioning board

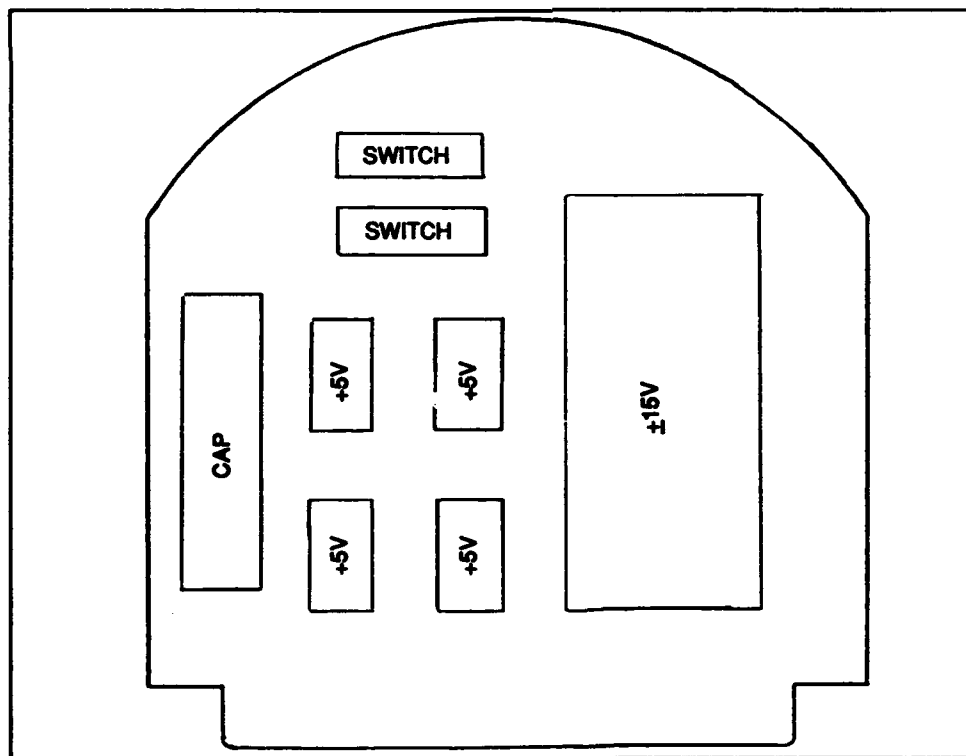

Figure A12. Power control board

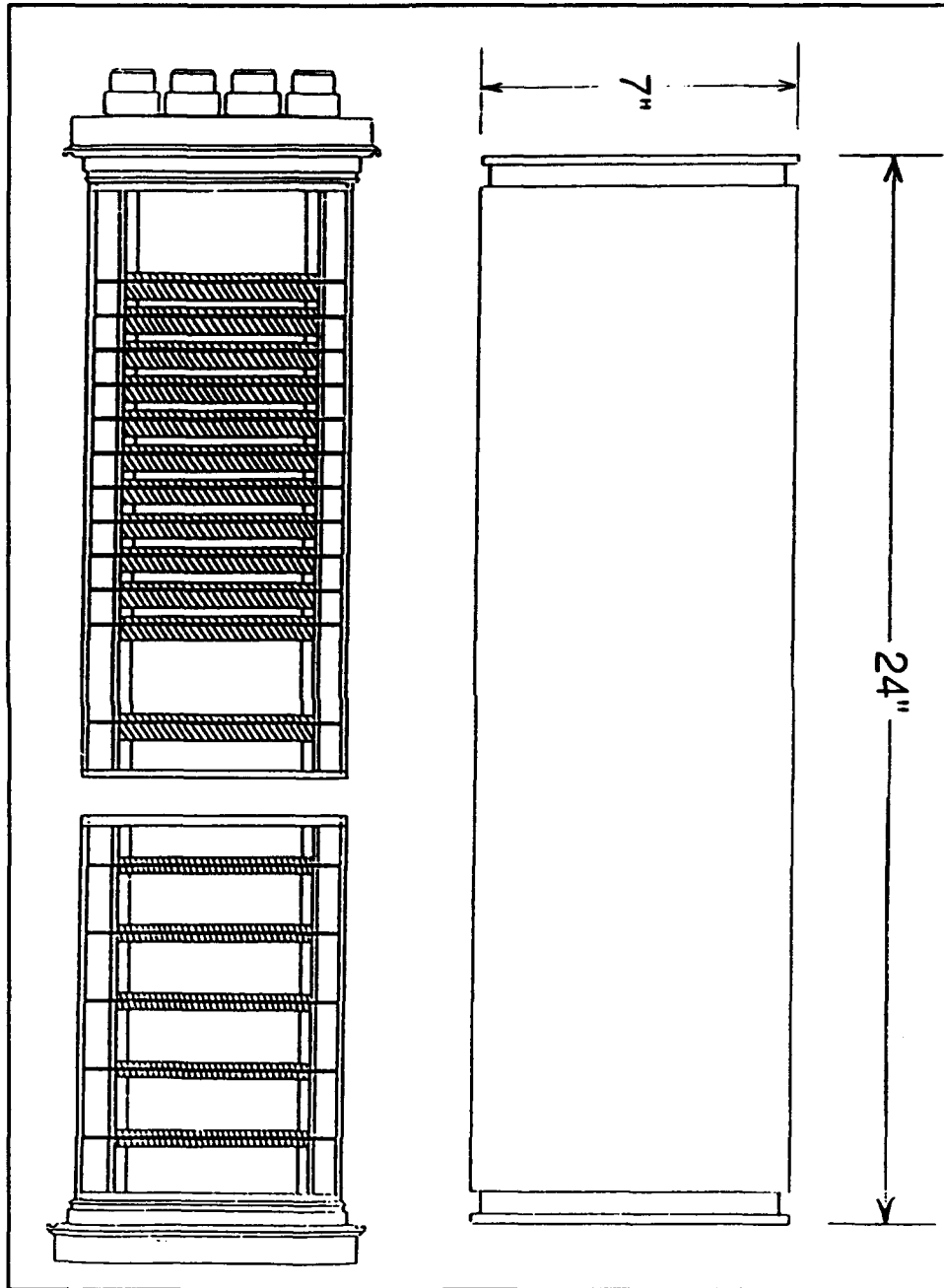

Figure A13. ARMS/BASS pressure housing

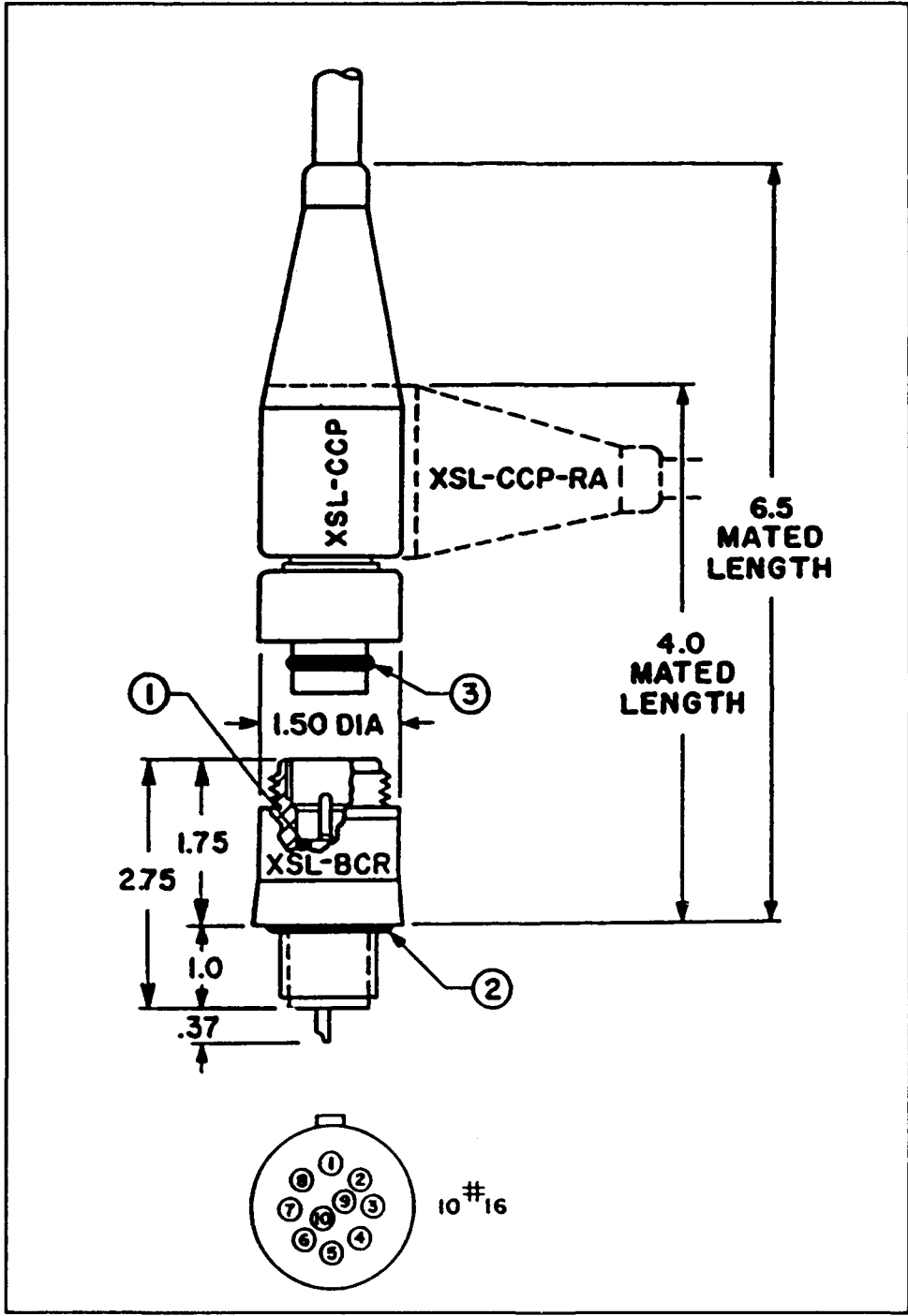

Figure A14. Profilometer connectors-XSL

SIZE	XSL			
TYPE	BCP	BCR	CCR	CCP
MATED (PSI) PRESSURE RATING	20,000	20,000	20,000	20,000
HEX DIMENSION ACROSS FLATS	FLATS 1.60	HEX 1.30	DIA 1.55	N/A
MATED LENGTH	N/A	6.5	10.0	N/A
THREAD SIZE	1-14 NF-2	1-14 NF-2	N/A	N/A
MOUNTING TORQUE (NOT TO EXCEED)	130 IN LBS.	130 IN LBS.	N/A	N/A
1. O-RING	2-017	2-016	2-016	N/A
2. O-RING	2-017	2-123	N/A	N/A
3. O-RING	N/A	N/A	N/A	2-017
4. O-RING	N/A	N/A	N/A	N/A
MATING CONNECTOR	XSL-CCR	XSL-CCP	XSL-CCP	N/A
OPTIONAL THREAD LENGTH	N/A	1.25	N/A	N/A
NUT & WASHER SET	N/A	1-14	N/A	N/A

Figure A15. XSL connector specifications

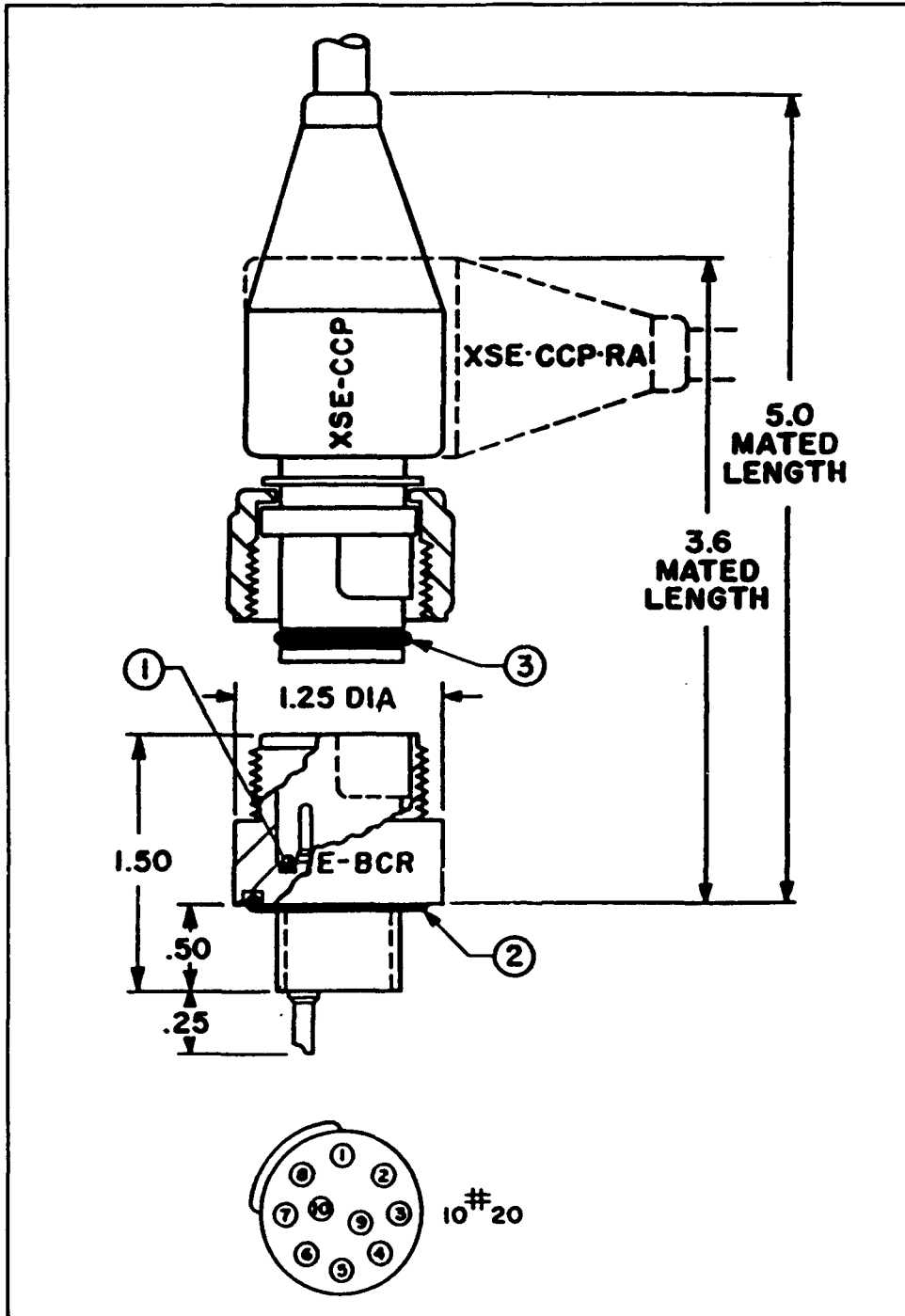

Figure A16. Other connectors-XSE

SIZE	XSE		
	BCR	CCR	CCP
TYPE			
MATED (PSI) PRESSURE RATING	10,000	10,000	10,000
HEX DIMENSION ACROSS FLATS	FLATS 1.12	DIA 1.25	N/A
MATED LENGTH	5.0	8.0	N/A
THREAD SIZE	3/4- 16 NF-2	N/A	N/A
MOUNTING TORQUE (NOT TO EXCEED)	75 IN LBS.	N/A	N/A
1. O-RING	2-015	2-015	N/A
2. O-RING	2-022	N/A	N/A
3. O-RING	N/A	N/A	2-014
4. O-RING	N/A	N/A	N/A
MATING CONNECTOR	XSE-CCP	XSE-CCP	N/A
OPTIONAL THREAD LENGTH	N/A	N/A	N/A
NUT & WASHER SET	3/4-16	N/A	N/A

Figure A17. XSE connector specifications

# **Appendix B**

## **Schematic Diagrams**

---

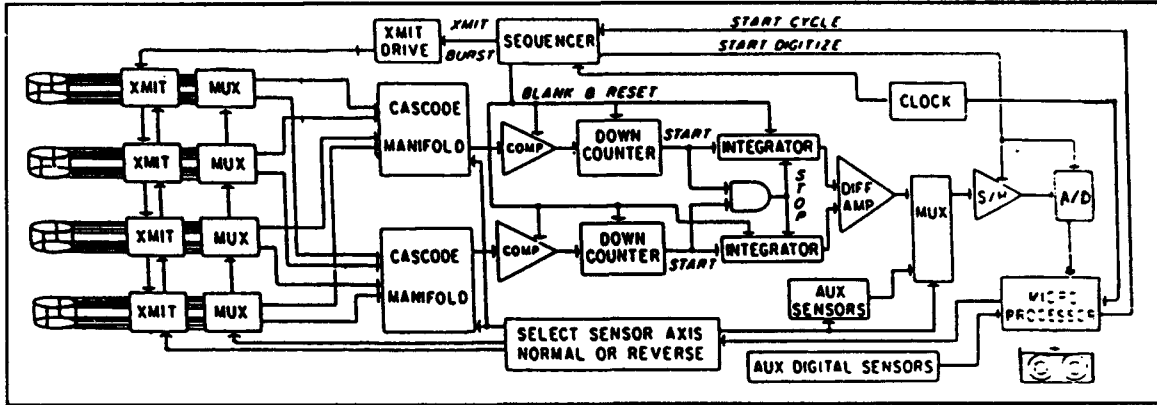

Figure B1. BASS block diagram

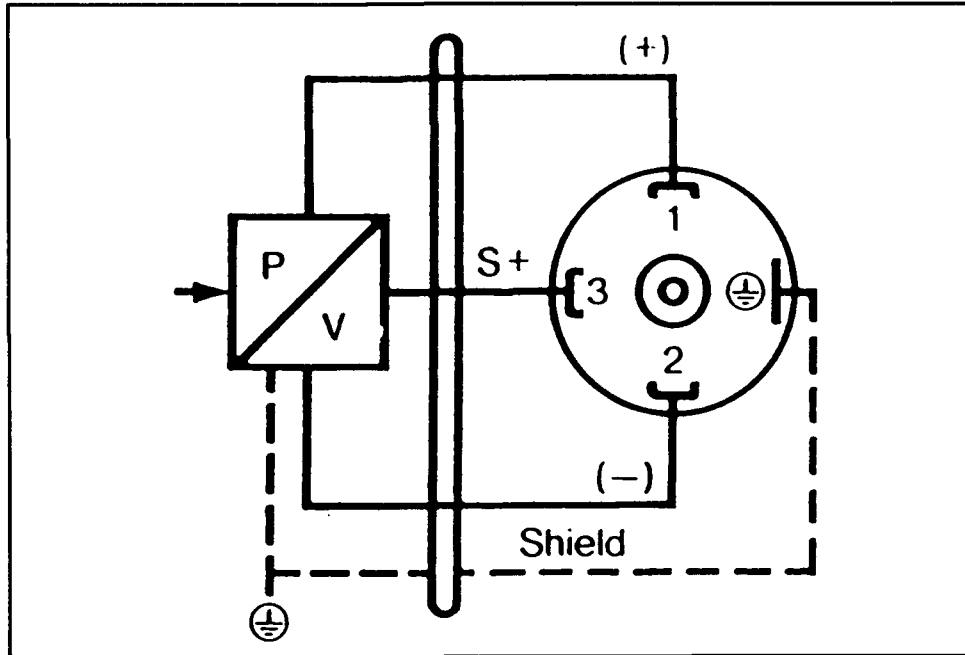

Figure B2. Pressure transducer

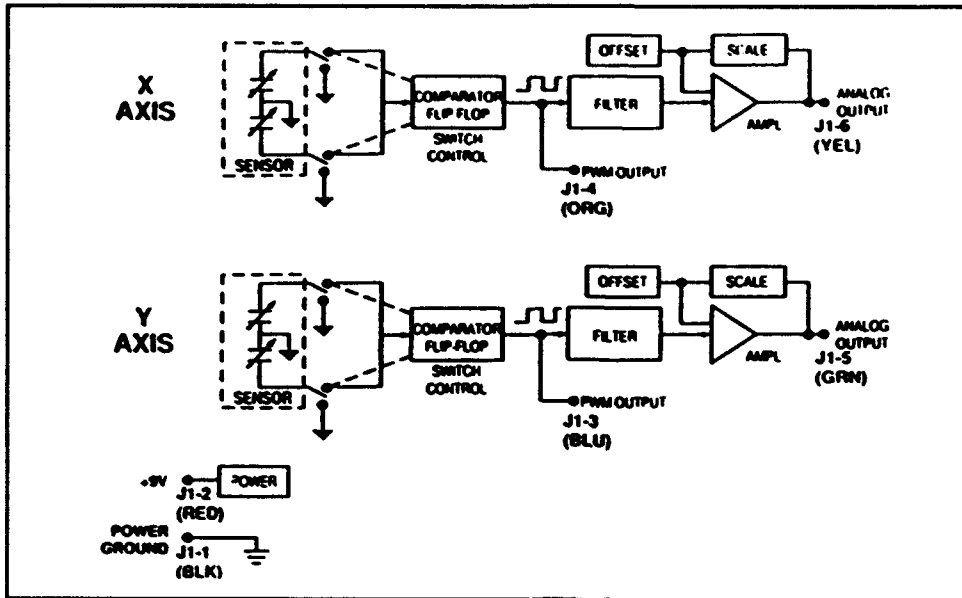

Figure B3. Inclinometer

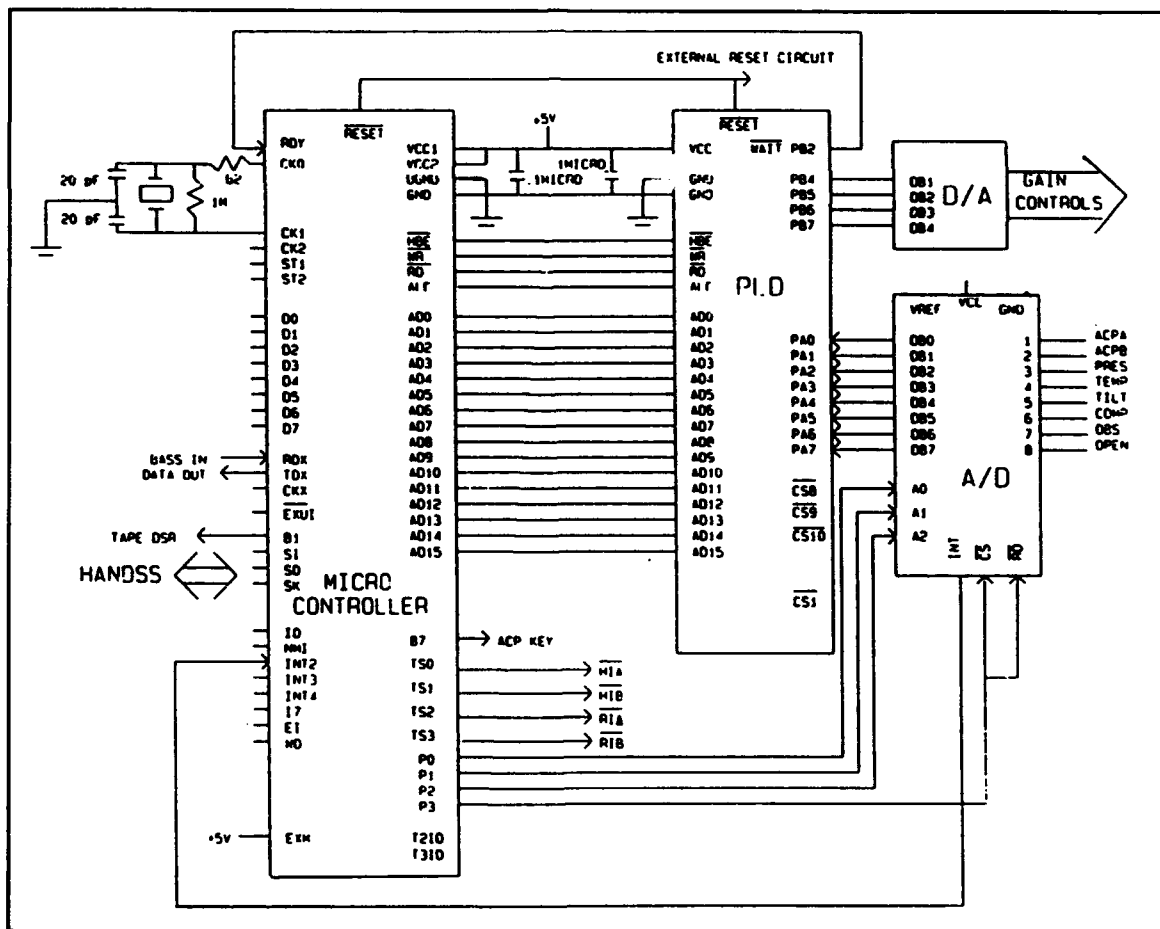

Figure B4. Controller board circuit diagram

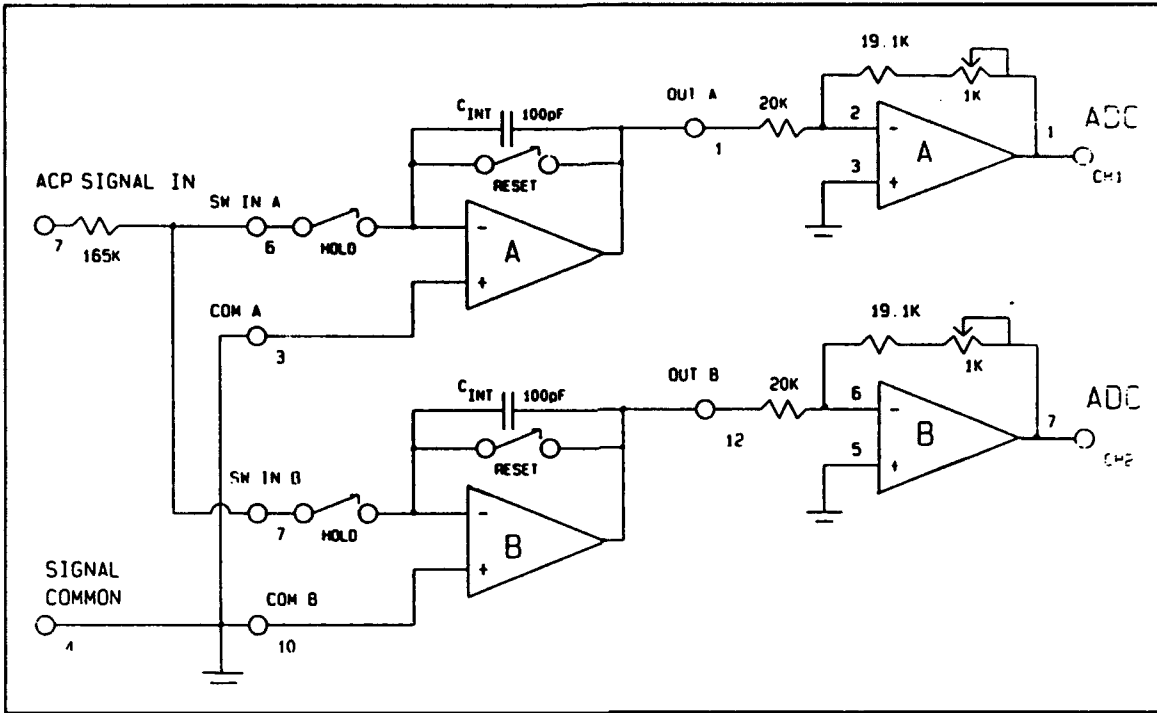

Figure B5. Profilometer circuit diagram

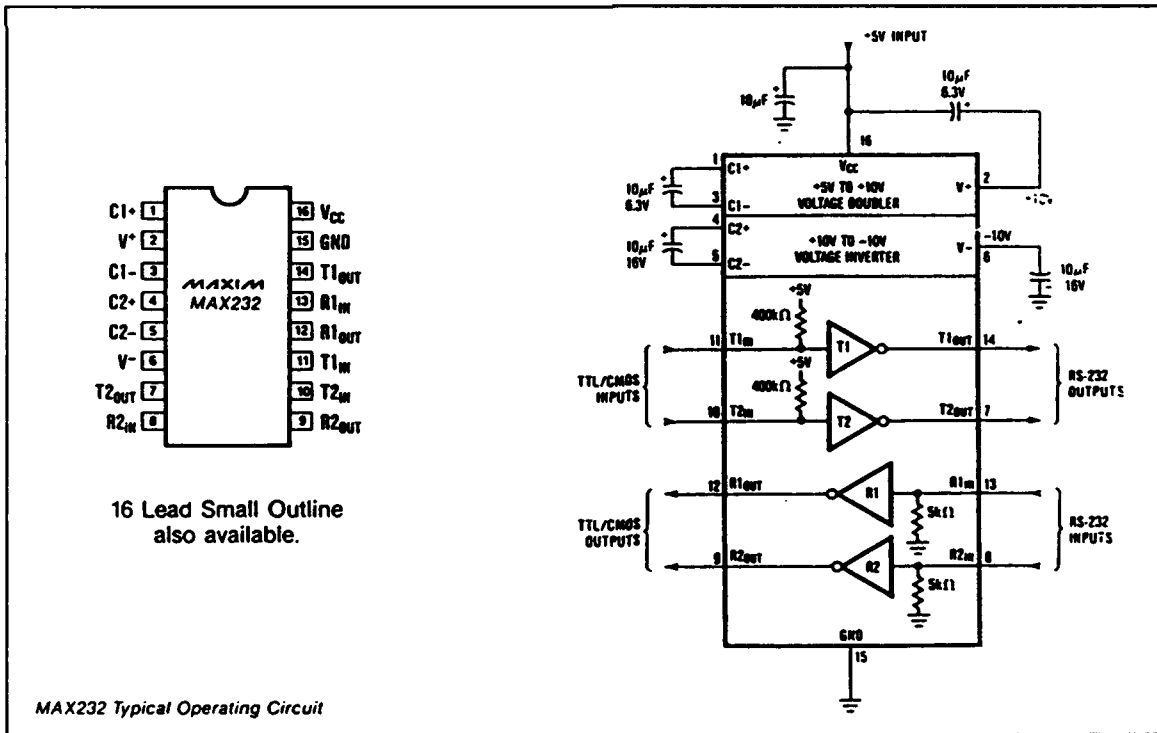

Figure B6. Serial driver diagram

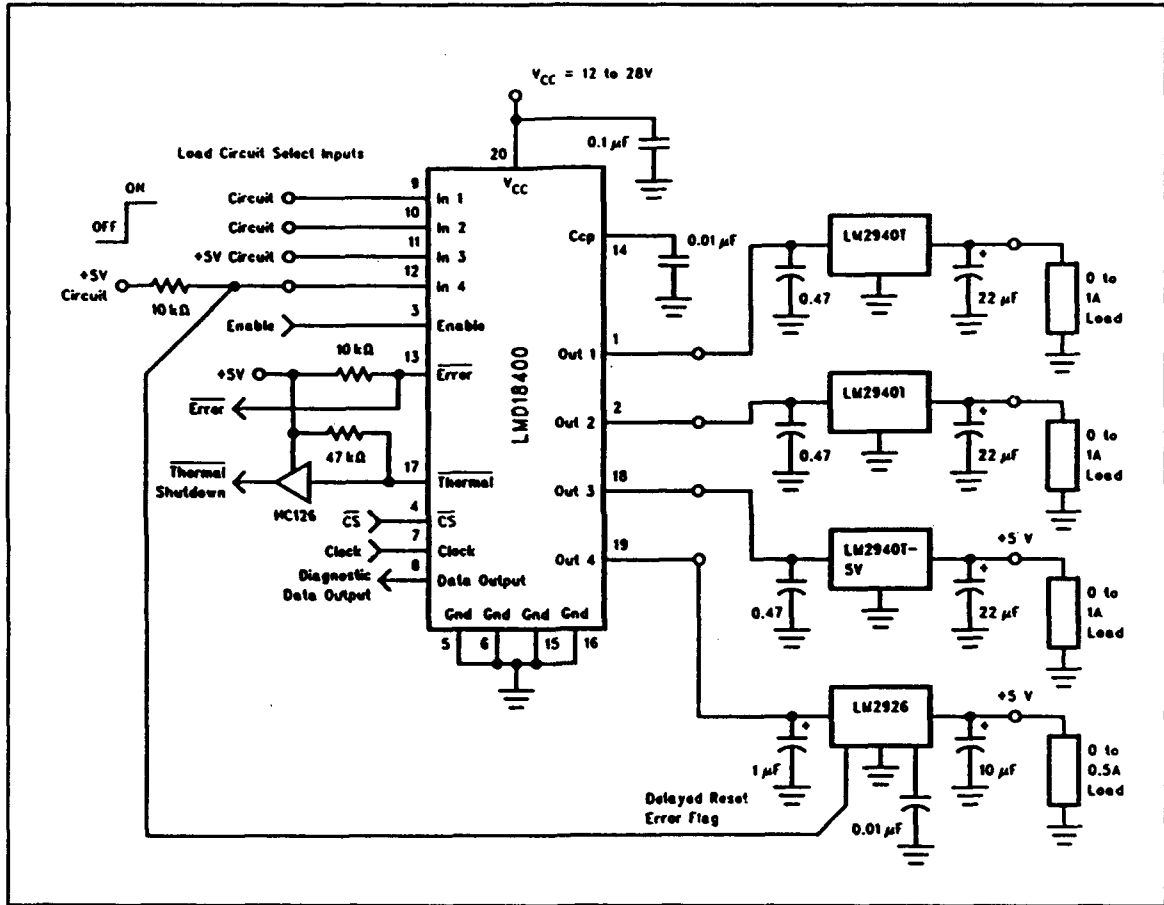

Figure B7. Power switcher diagram

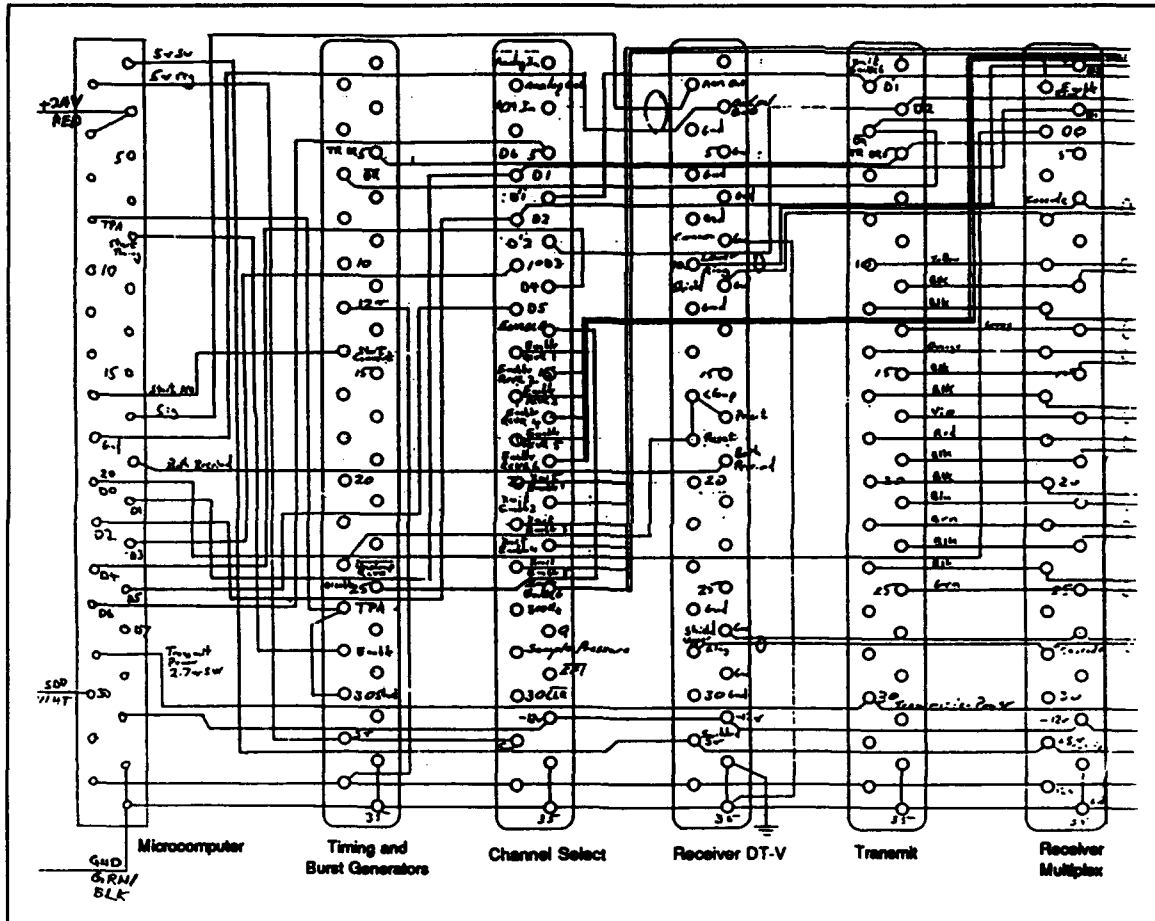

Figure B8. BASS chassis diagram

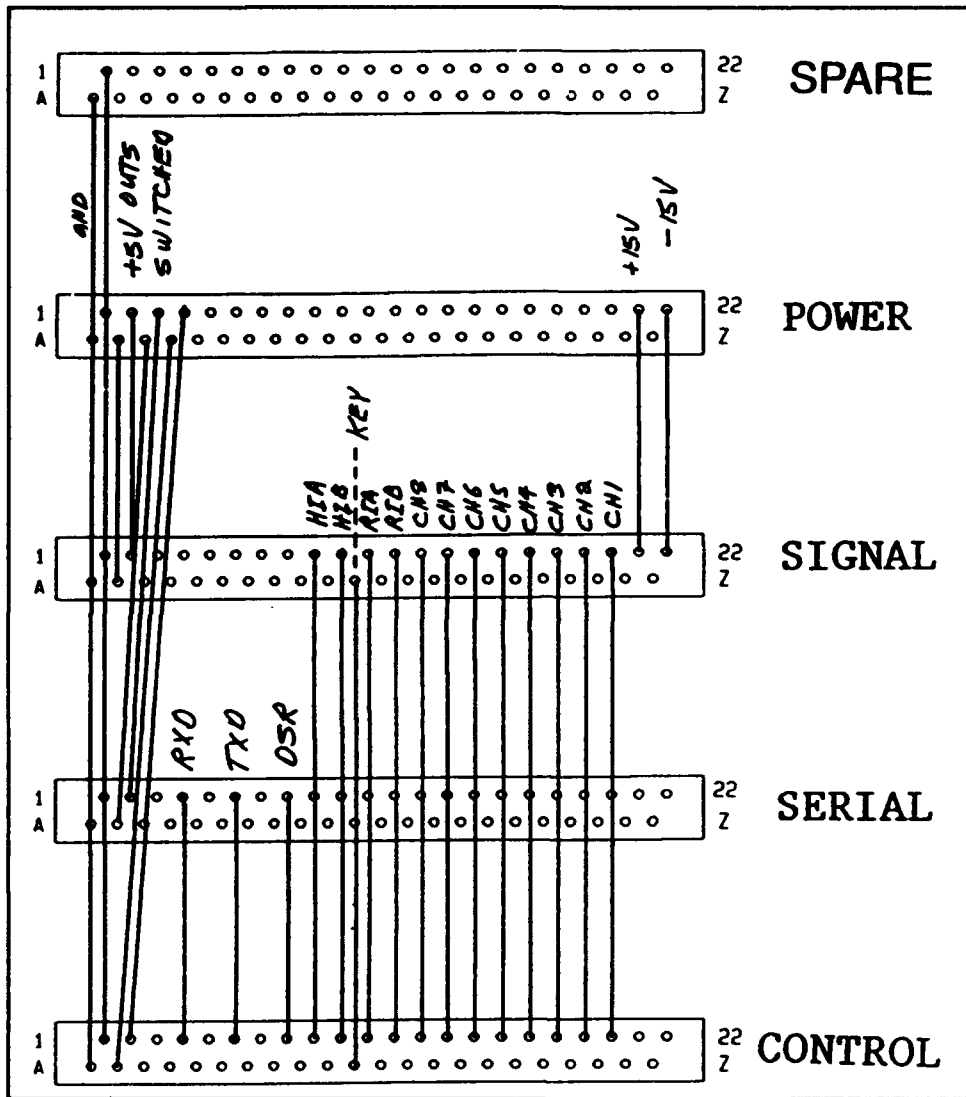
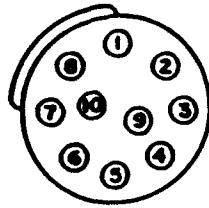

Figure B9. ARMS chassis diagram



POWER / TAPE CONNECTOR

1. RXDAT into tape drive (green)
2. Spare tape line ( shield )
3. Spare
4. Spare
5. Spare
6. Spare tape line ( white )
7. Tape DSR ( red )
8. Tape GND ( black )
9. +24 volt D.C. from batteries ( red )
10. GND from batteries (black)

Figure B10. Power/tape connector pinout

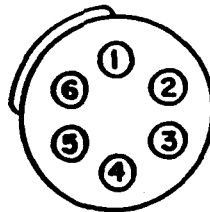

OPERATOR INTERFACE CONNECTOR

1. GND
2. BATTERY SUPPLY
3. TAPE SUPPLY
4. TXC INTO TAPE
5. RXD INTO HPC
6. CONTROL LINE

Figure B11. Operator interface connector pinout

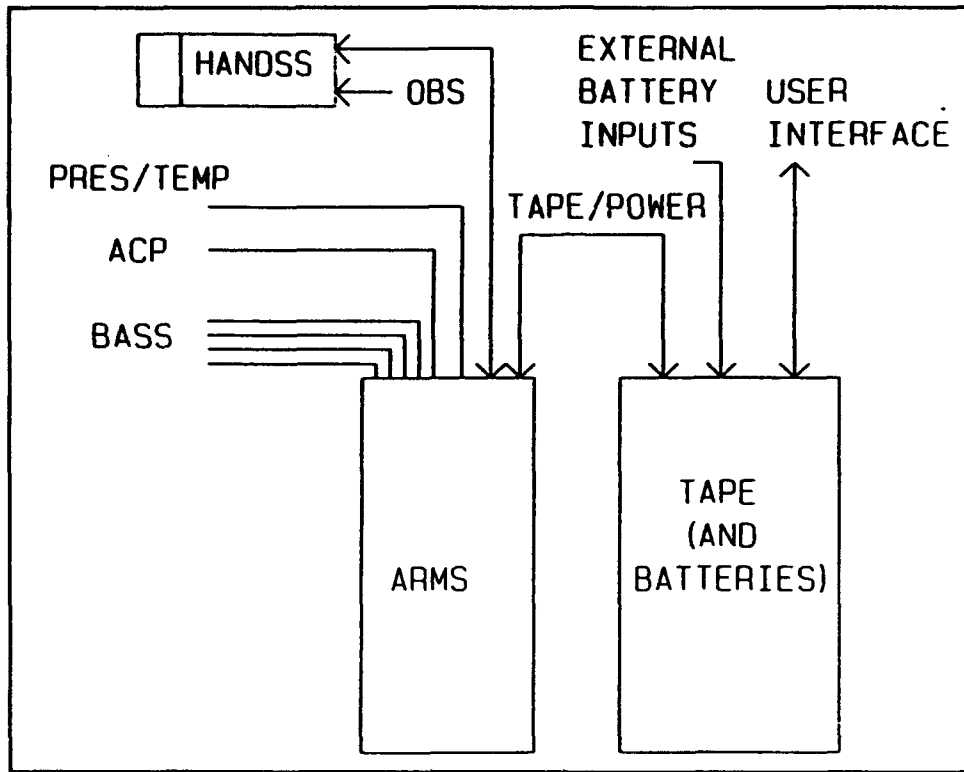

Figure B12. External cabling diagram

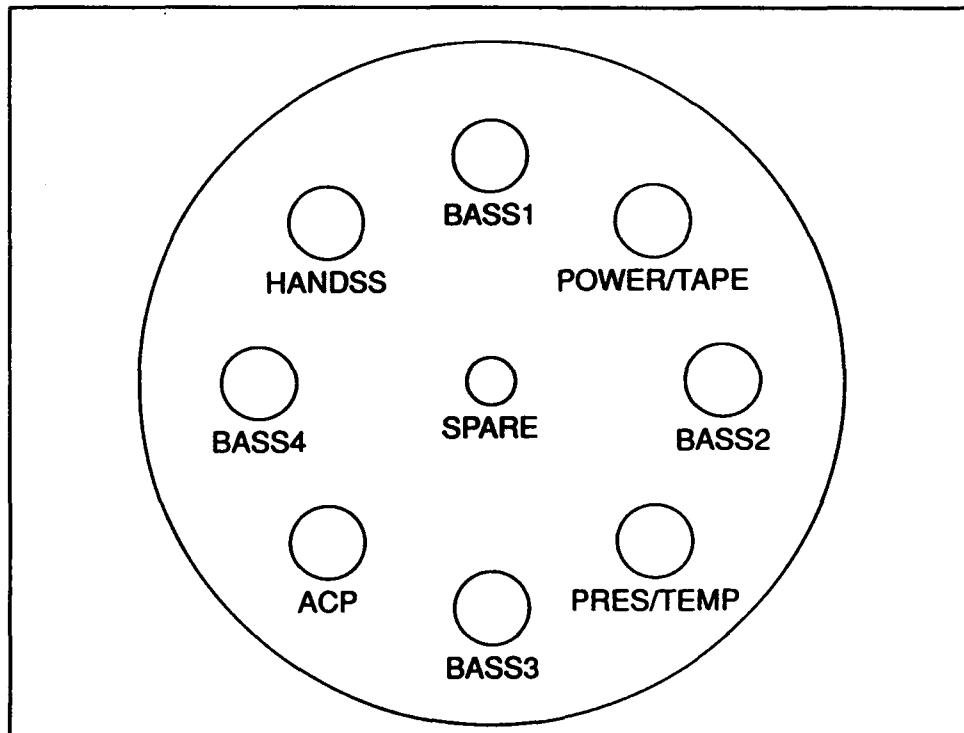

Figure B13. External connector layout

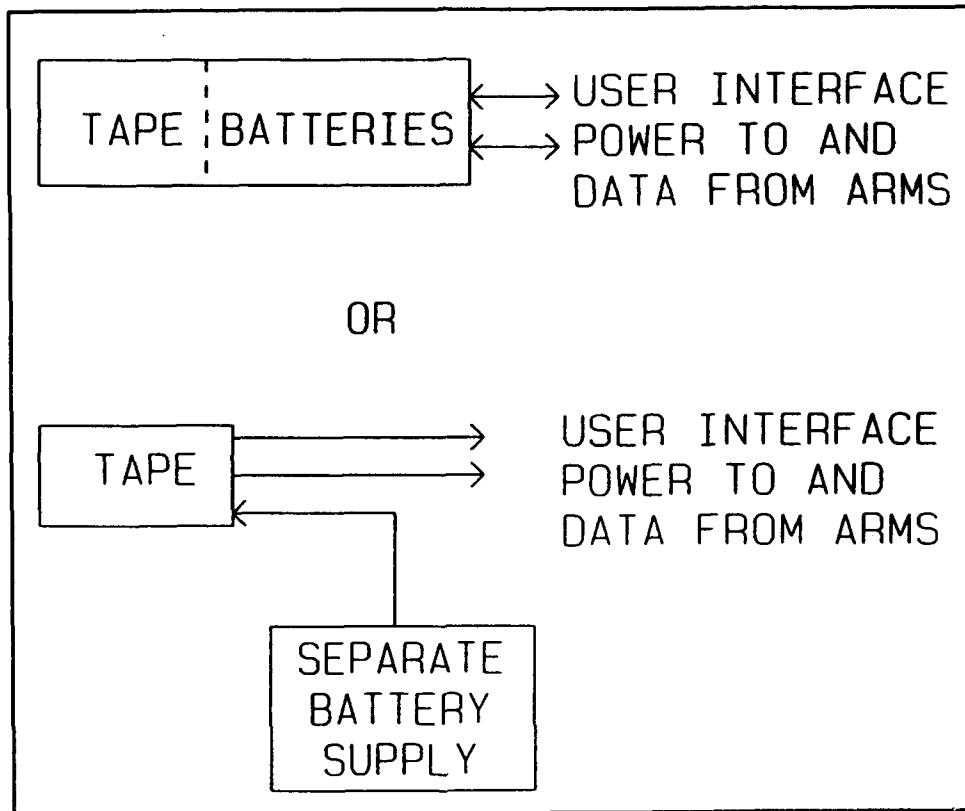

Figure B14. Battery configuration diagram

# **Appendix C**

## **Circuit Signals and Timing Diagrams**

---

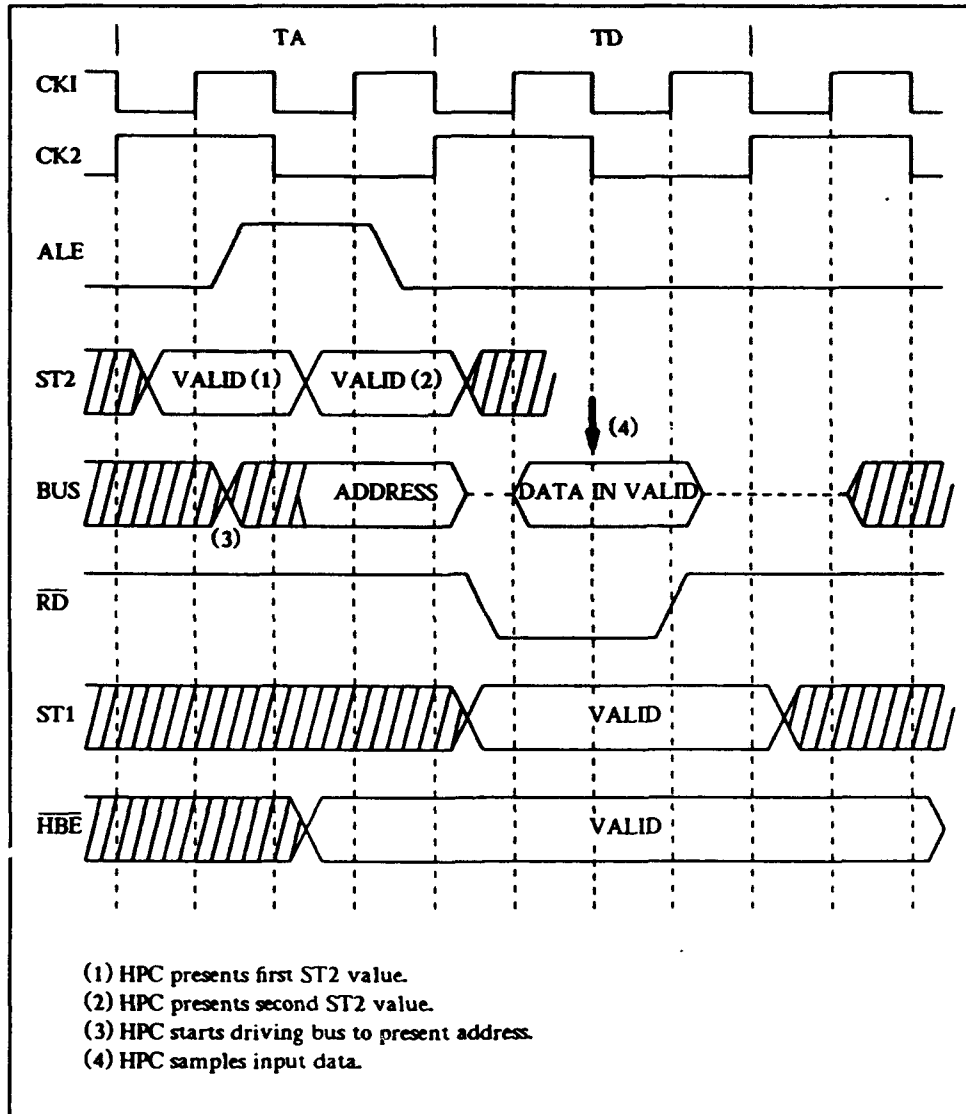

Figure C1. Controller read cycle - no-wait states

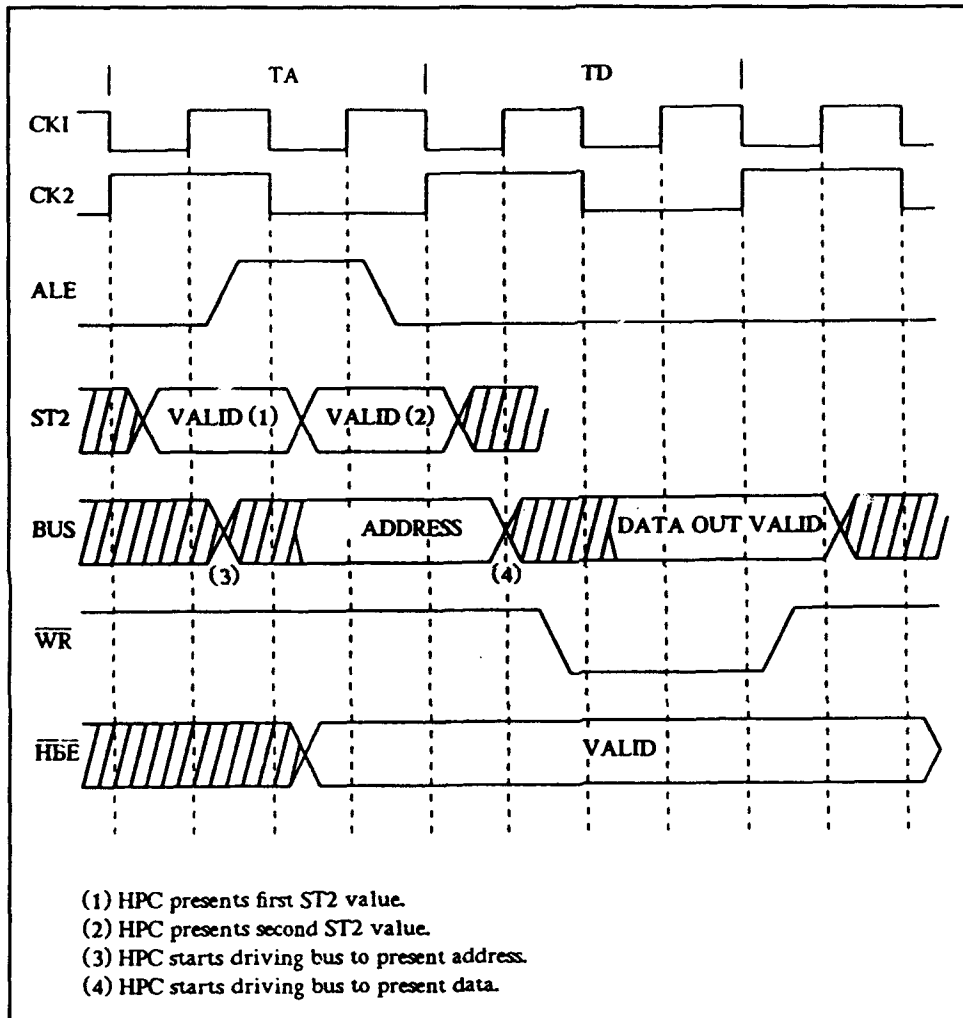

Figure C2. Controller write cycle - no-wait states

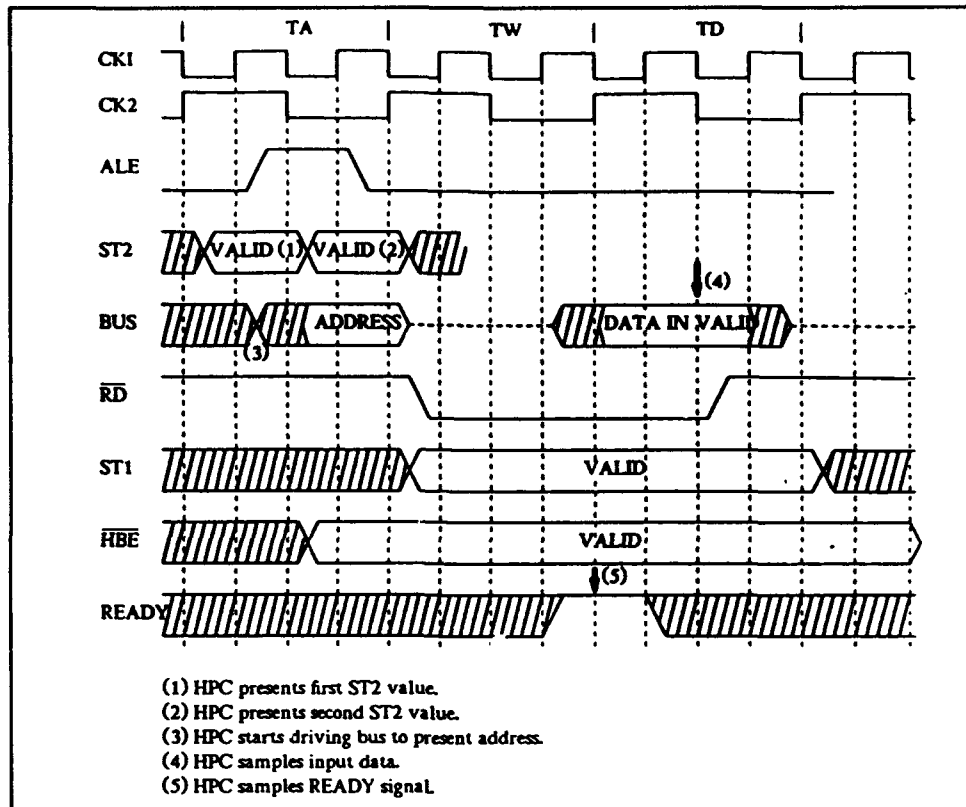

Figure C3. Controller read cycle - one-wait state

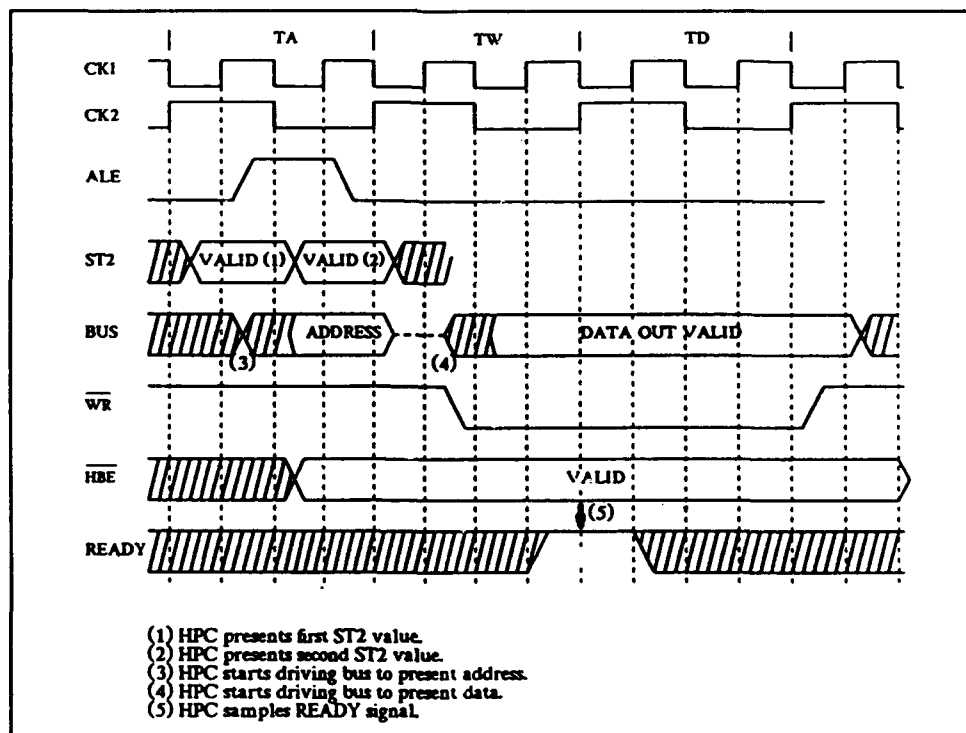

Figure C4. Controller write cycle - one-wait state

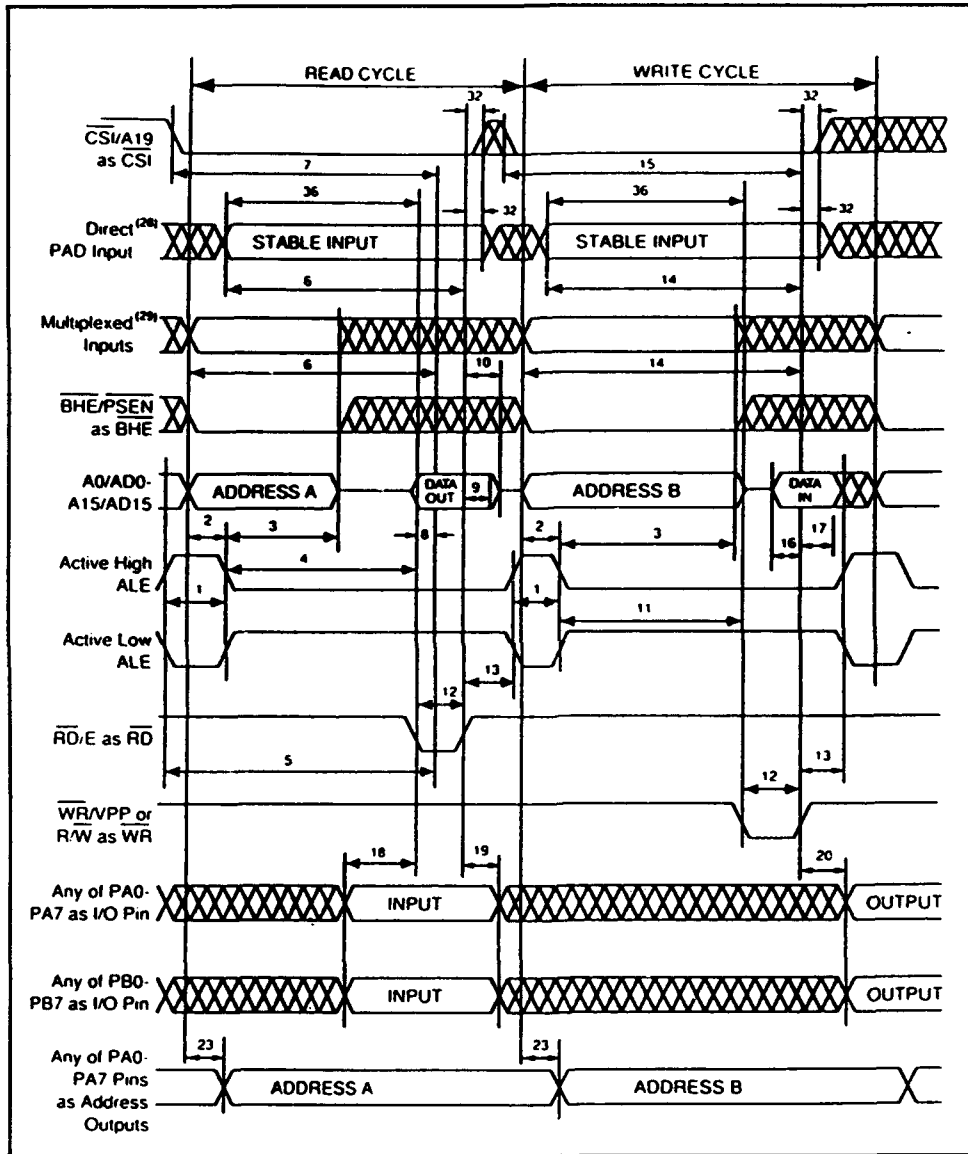

Figure C5. Programmable logic device timing - read and write

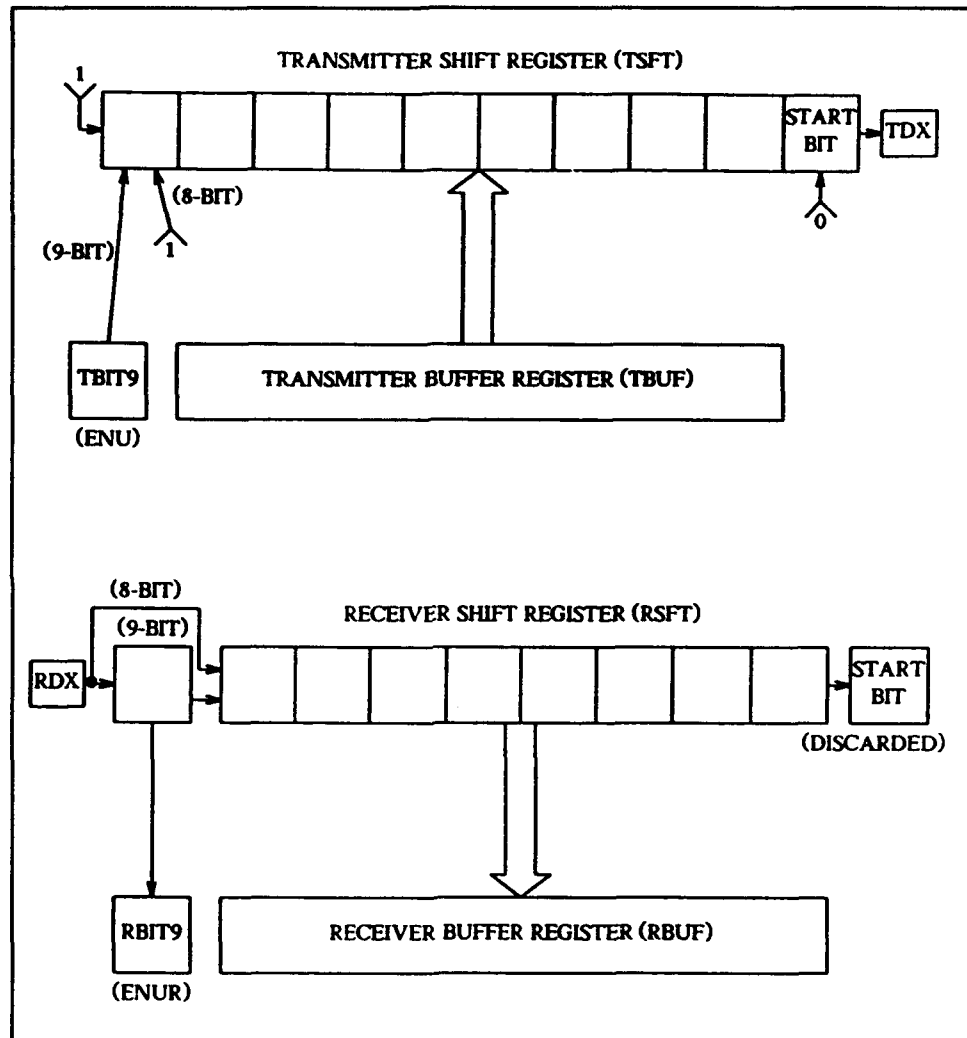

Figure C6. Controller serial communication data flow

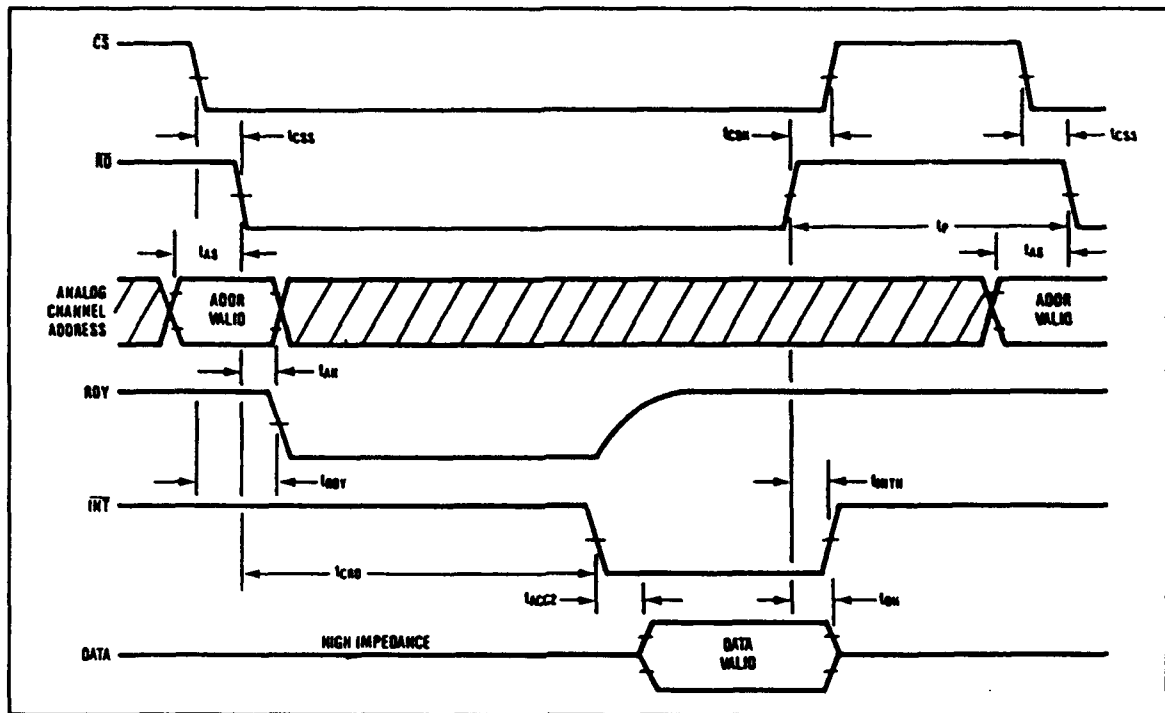

Figure C7. Analog conversion timing diagram

**TIMING CHARACTERISTICS**  
(V<sub>DD</sub> = +5V, V<sub>REF+</sub> = +5V, V<sub>REF-</sub> = GND, T<sub>A</sub> = T<sub>MIN</sub> to T<sub>MAX</sub>, unless otherwise specified.)

PARAMETER	SYMBOL	CONDITIONS	T <sub>A</sub> = +25°C			MAX15XC/E AD782XK/L/B/C		MAX15XM AD782X7/U		UNITS	
			MIN.	TYP.	MAX.	MIN.	MAX.	MIN.	MAX.		
CS to RD, Setup Time	t <sub>CSs</sub>		0			0		0		ns	
CS to RD, Hold Time	t <sub>CSH</sub>		0			0		0		ns	
Multiplexer Address Setup Time	t <sub>AS</sub>		0			0		0		ns	
Multiplexer Address Hold Time	t <sub>AH</sub>		30			35		40		ns	
CS to RDY Delay	t <sub>RDY</sub>	C <sub>L</sub> = 50pF, R = 5kΩ		30	40		60		60	ns	
Conversion Time (Mode 0)	t <sub>CRD</sub>			1.6	2.0		2.4		2.8	μs	
Data Access Time After RD	t <sub>ACC1</sub>				85		110		120	ns	
Data Access Time After INT, Mode 0	t <sub>ACC2</sub>			20	50		60		70	ns	
RD to INT Delay (Mode 1)	t <sub>INTH</sub>	C <sub>L</sub> = 50pF		40	75		100		100	ns	
Data Hold Time	t <sub>OH</sub>				60		70		70	ns	
Delay Time Between Conversions	t <sub>P</sub>		500			500		600		ns	
RD Pulse Width (Mode 1)	t <sub>RD</sub>			60	600		60	500	60	400	ns

Figure C8. Analog conversion timing characteristics

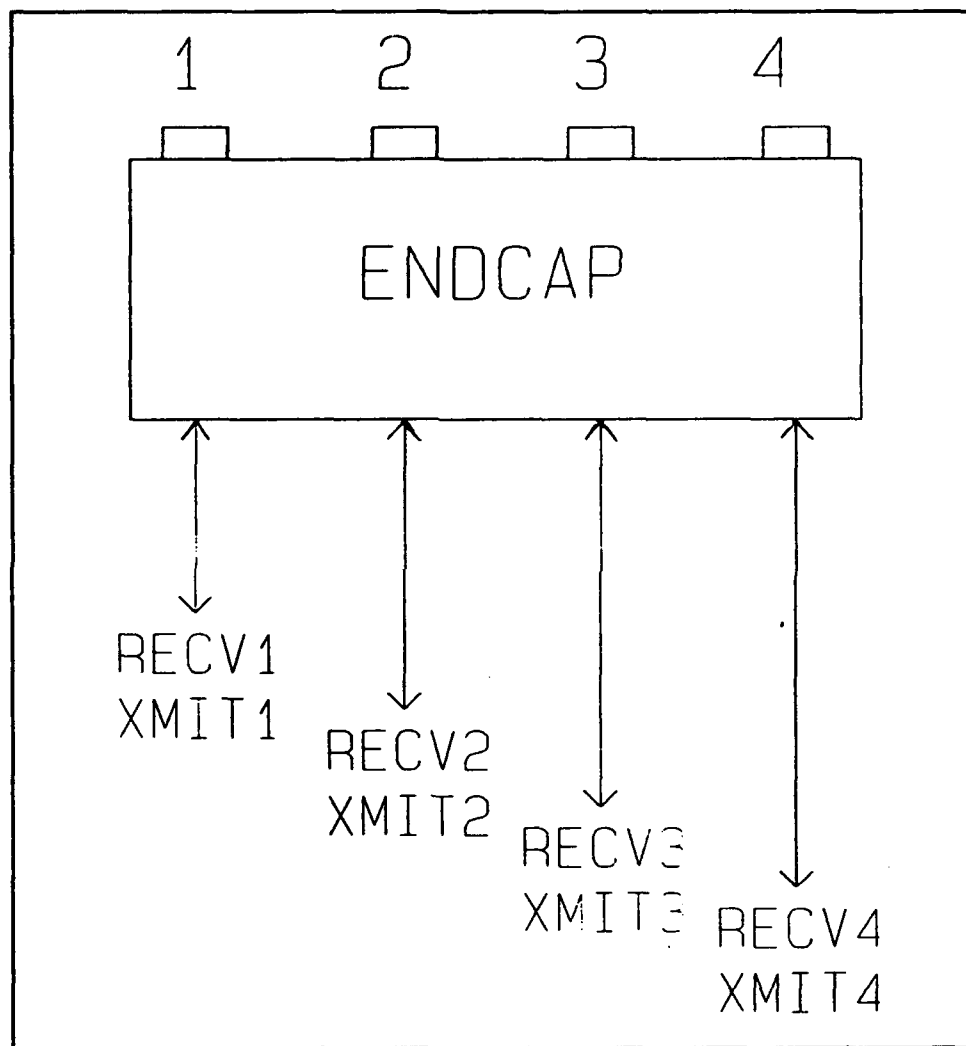

Figure C9. Internal instrument signal cabling - BASS

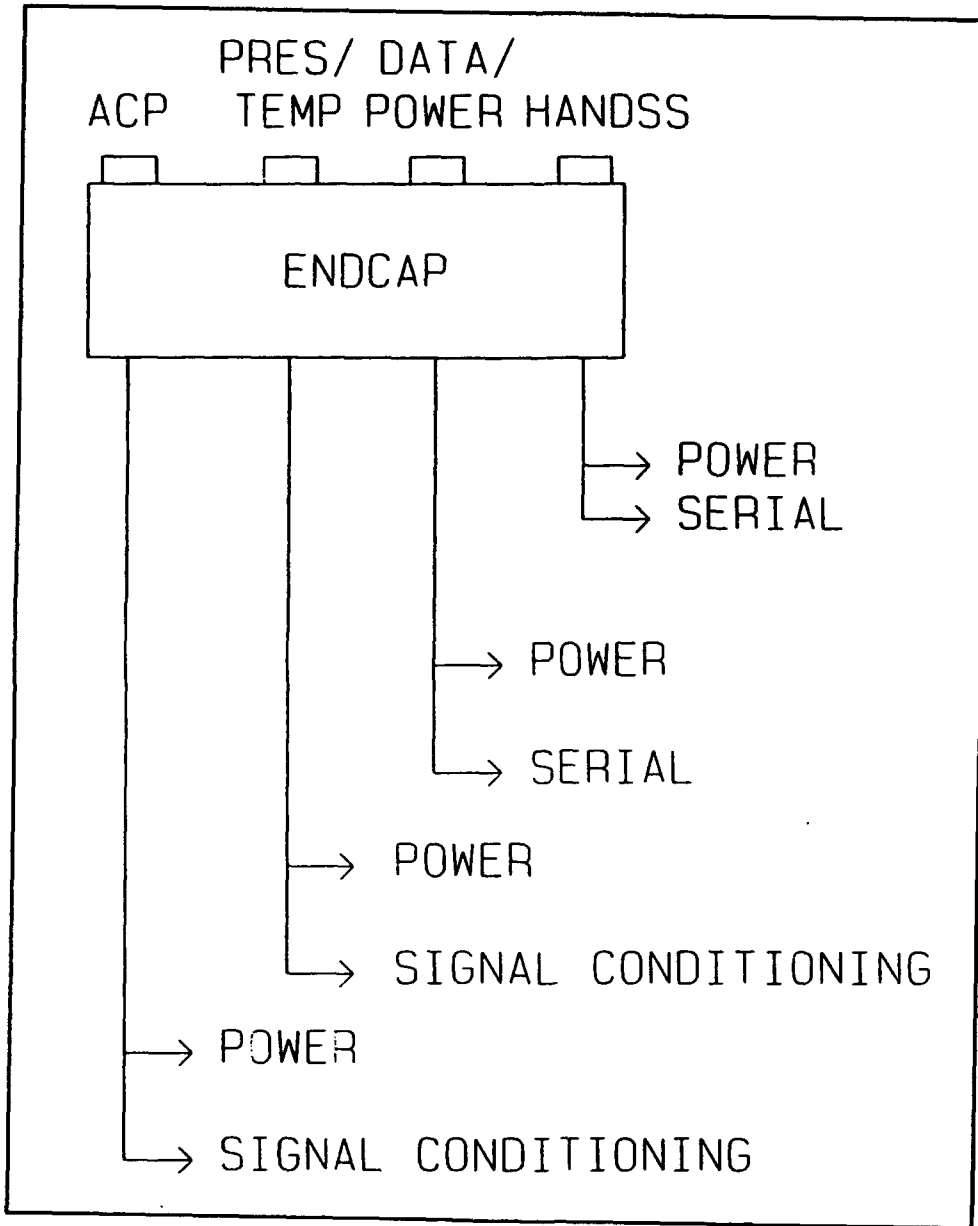

Figure C10. Internal instrument signal cabling - ARMS

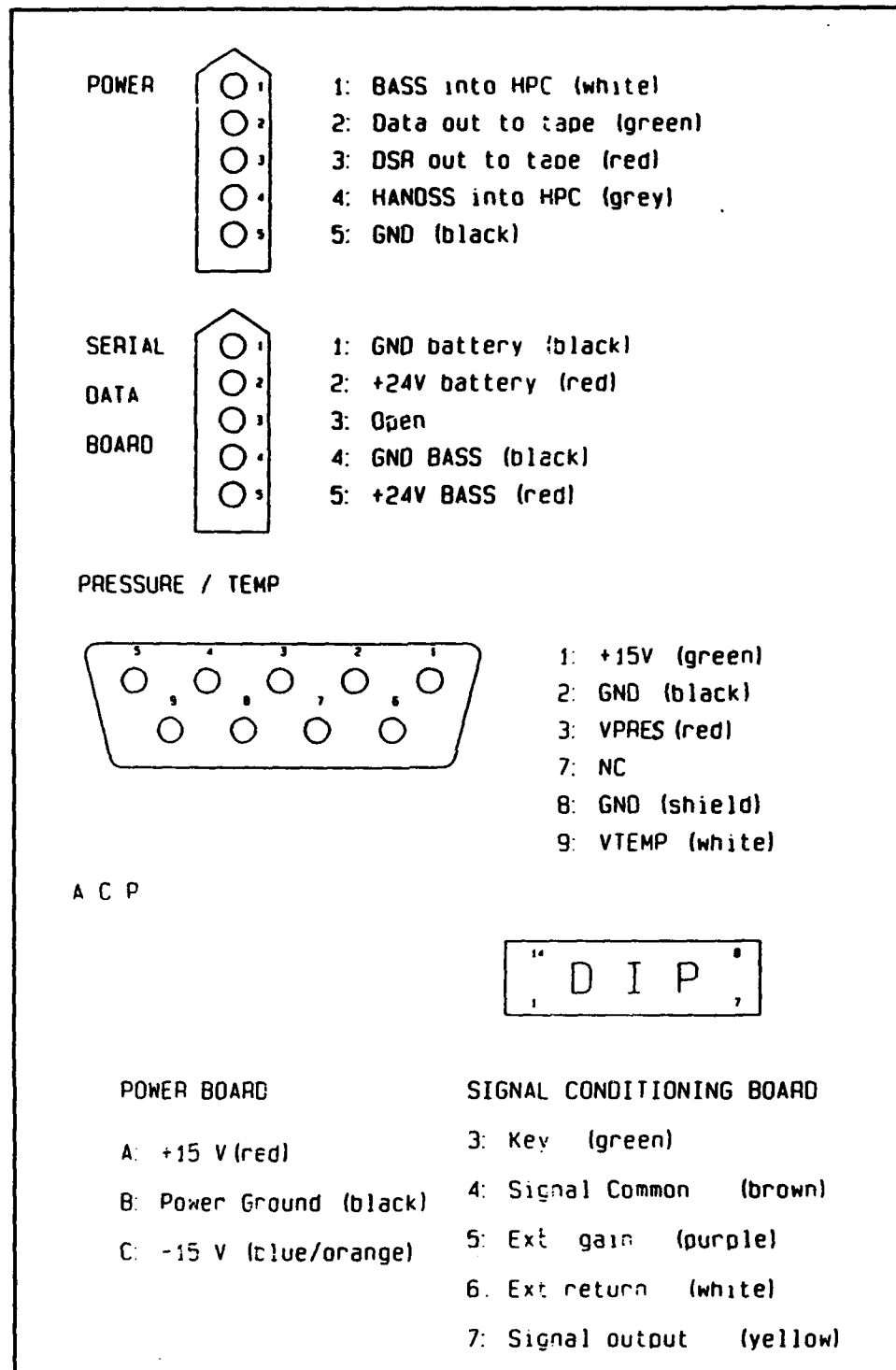

Figure C11. ARMS internal connector lines

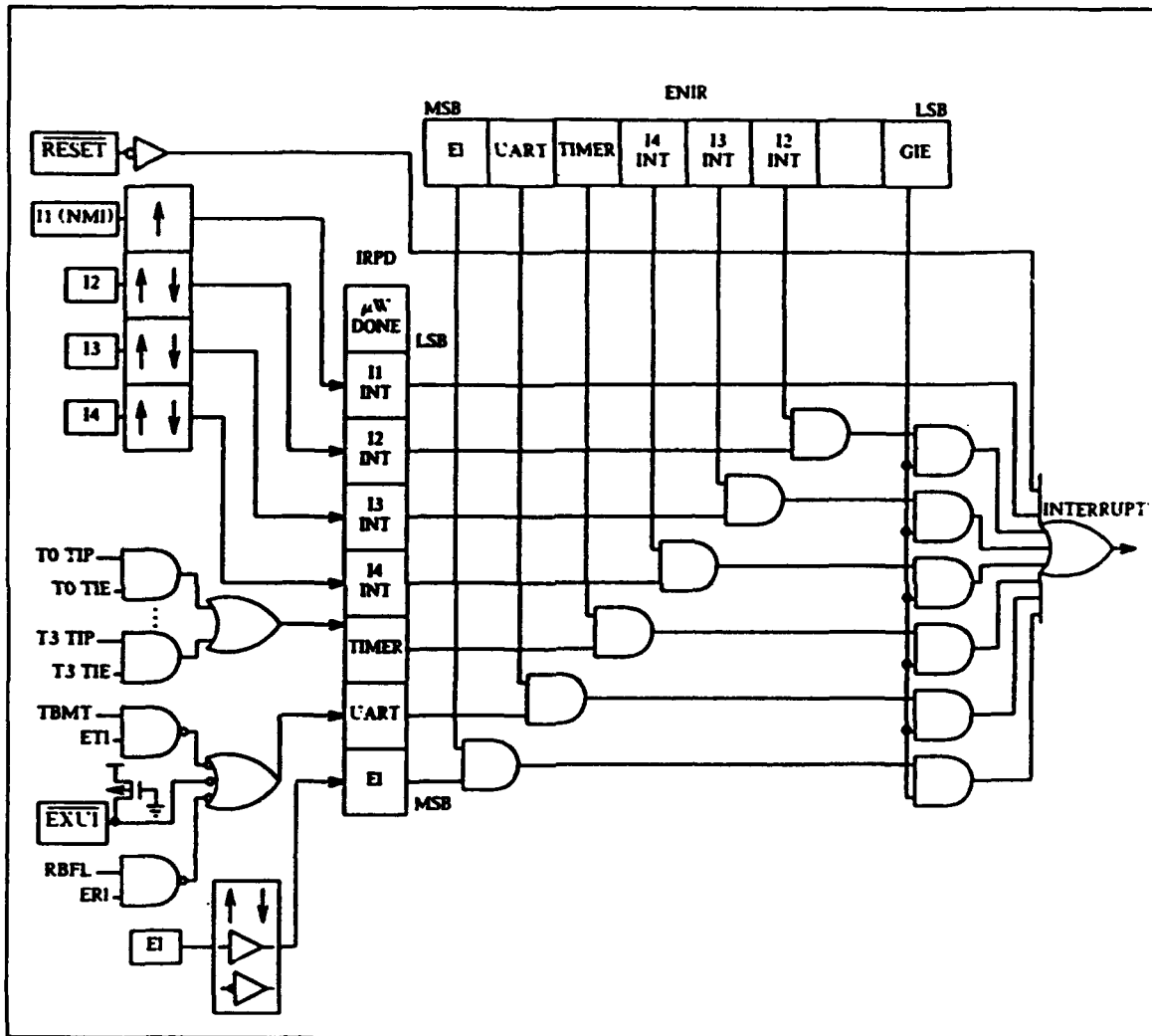

Figure C12. Block diagram of controller interrupt logic

# **Appendix D Software**

---

## Operational Code of Core Program

.TITLE ARMSOS, 'Operating System of ARMS'

```
-----  
ARMSOS:VER 1.0 OS of Acoustical Resuspension Measuring System  
  Ohio State University Coastal Engineering Lab  
-----
```

.includ reg16083.inc

```
basslen = 0x26 ; bass data buffer size (1/4 sec)  
proflen = 0x78 ; 120 bins of profilometer size (1 sec)  
exlen   = 0x18 ; 6X4X1 bytes storage space for rest samples
```

```
.sect buffer,base,rel ; sector definition  
stks   : .dsw 0x10 ; make room for stack  
bassbuf : .dsb basslen ; make room for bass  
exbuf  : .dsb exlen ; make room for extra transducers
```

```
gapin   : .dsw 1 ; not xmit busy signal check flag  
numchr  : .dsw 1 ; number of holding bytes in bassbuf  
numout  : .dsw 1 ; number of sent out from bassbuf  
cadin   : .dsw 1 ; current address of incoming bass byte in buffer  
cadout  : .dsw 1 ; current address of outgoing bass byte in buffer  
endbuf  : .dsw 1 ; address of top bass buffer  
pendbuf : .dsw 1 ; top address of profbuf buffer  
padout  : .dsw 1 ; current address of outgoing prof byte from profbuf  
temp    : .dsw 1 ; temporary address holding word  
block   : .dsw 1 ; block counter (10 min)  
record  : .dsw 1 ; record counter (1 sec)  
oneblk  : .dsw 1 ; 1 block(10min) = 600 rec(sec)  
intflag : .dsb 1 ; flag of integrater indicator  
addpt   : .dsw 1 ; address pointer of prof data addition  
profcnt : .dsb 1 ; profile counter for 1 frame addition  
exbufptr : .dsw 1 ; extra transducers' readings storing pointer
```

.endsect

```
.sect vars,ram16,rel ; sector for holding temporary address or flags  
profbuf : .dsb proflen ; make room for profbuf  
profadd : .dsw proflen ; make room for addition storage  
.endsect
```

.sect code,rom16,rel

.ipt 5, checkin

```
go:  
    ld    psw,#0ff18 ; enable external memory with 1 wait state  
          ; (EA bit on)  
    ld    ircd,#00005 ; enable RDY function giving extra wait  
          ; and set I2 pin polarity high  
    ld    sp,#stks ; initialize stkpnr  
    jsr   setup ; general initial setup  
  
    ld    divby,#02250 ; setup CKX pin for 9600 baud (@20MHz)  
  
uloop:  
    jp    uloop ; wating input interrupt
```

-----

```

;initialization subroutine - to get the system ready for an UART op.
;=====
setup:
    ld    enir,#00000    ;disable all interrupts
    ld    irpd,#00000    ;.. all pendings
    ld    enur,#00000
    ld    enu,#00000

;initialize timers

    ld    tmode,#04440    ; initlz T1,T2,T3 timers
    nop
    nop
    ld    tmode,#0ccc8

    ld    divby,#00000    ; stop timers
    ld    t3,#00          ; initlz t3 register
    ld    r3,#00          ; initlz r3 register

    ld    portb,#0fb18    ; initial state of B pins
    ld    dirb,#0639f     ; b0 = tdx, b1 = dsr, b2 = uart clk,
                        ; b3 = T2, b4 = T3, b7 = KEY
                        ; b8 = /HIA, b9 = /HIB, b10 = ALE
                        ; b11 = /WR, b12 = /HBE, b13 = /RIA
                        ; b14 = /RIB, b15 = /RD

    ld    bfun,#0001d     ; port B functions as tdx, clk, T2, T3

    ld    cadin,#bassbuf  ; initlz bassbuf parameters
    ld    cadout,#bassbuf
    ld    endbuf,#bassbuf+basslen-1
    ld    numchr,#00000
    ld    numout,#00000

    ld    padout,#profbuf ; initlz profbuf parameters
    ld    pendbuf,#profbuf+proflen-1

    ld    block,#00001    ; initlz block counter
    ld    record,#00000   ; initlz record counter
    ld    gapin,#00000    ; initlz calm detect pointer
    ld    exbufptr,#exbuf ; reset pointer after 1-sec samplings

; clear profilometer data buffer location
bufclr:
    ld    bk,#profbuf,#profbuf+proflen-1 ; set clearing bounds
    clr   a                               ; reset A register
    xs   a,[b+].b
    jp   bufclr

; setup routine for ADC and PSD operations

    ld    intflag,#000    ; initlz integrater sel flag as Ch A
    ld    portp,#01000    ; initlzly select AD channel 1 as Logic 0
                        ; initlz /CS and /RD of AD as logic 1

    ld    a,rbuf          ; clear eri
    ld    enui,#002       ; uart clk and eri
    ld    enir,#041       ; enable uart intrpt

    ret

```

```

;-----
; interrupt handler
;-----

checkin:
    ifbit    1,enu           ; if rbf1 is set, means busy in receiving
    jp      rx              ; go to receiver intrpt. rtn.

    inc     gapin           ; recongnize no event
    ifgt   gapin,#00010    ; consec. x10 events of waiting input
    jp     pxini           ; check prof xmit

    ifgt   numchr,#00      ; means some bass data waiting for xmit
    jp     tx              ; xmit a bass data routine

    jp     checkin         ; waiting next event

pxini:
    jsr    profsample      ; sample profilometer eight times

    ifgt   numout,#0017c   ; check number of bytes sent out
    jsr    pxmit           ; YES, process prof data sending out

    jp     checkin         ; waiting next event

;-----
; Subroutines
;-----

rx:
    ld     a,rbuf           ; get the character
    inc   numchr           ; increase # of holding bass bytes cnt.
    st    a,[cadin].b     ; store in the circ. buffer
    ld    a,cadin         ; get input buffer ptr.
    inc   a               ; next location in the buffer
    ifgt  a,endbuf        ; is ptr > end of buffer ?
    ld    a,#bassbuf      ; YES, so initlz. it to start
    st    a,cadin         ; No, save the current ptr
    ld    gapin,#0000     ; reset calm period detector
    jp    checkin        ; wating consec. bass input

tx:
    ld    a,[cadout].b    ; get the char. to be tx from buffer
    jsr   chkopen         ; check whether the pin open now
    st    a,tbuf          ; write onto the tx buffer
    ld    a,cadout        ; get the ptr to buffer
    inc   a               ; ptr to next location
    ifgt  a,endbuf        ; ptr > end of buffer ?
    ld    a,#bassbuf      ; YES, so wrap it to begining
    st    a,cadout        ; put it back
    ld    a,numchr        ; load holding counter
    dec   a               ; decrease
    st    a,numchr        ; put it back
    inc   numout           ; increment of sent out counter in 1 sec
    ld    gapin,#00000    ; reset interval counter
    jp    checkin        ; waiting next event

pxmit:
    jsr   average         ; do ensemble averaging of prof data
    ; one averaged bin takes two bytes(word)
    ; later it has to be one byte.
    ld    padout,#profbuf ; re_initlz padout pointer
    jsr   heading         ; do heading job (record, block)

```

```

cont:
    ld    a,[padout].b    ; load a prof byte to send out
    jsr   chkopen        ; check whether the pin open now
    st    a,tbuf         ; sending out
    ld    a,padout       ; load loading pointer in profbuf
    inc   a              ; increase pointer
    ifgt  a,pendbuf      ; check top of profbuf
    jp    onerec         ; do the record processing
    st    a,padout       ; save current pointer info

    jp    cont           ; send next byte process

onerec:
    ld    a,#profbuf     ; YES, initlz the pointer
    st    a,padout       ; save current pointer info
    ld    numout,#00000  ; reset the sent out counter
    ld    gapin,#00000   ; reset interval counter
    ld    exbufptr,#exbuf ; reset pointer after 1-sec samplings

    inc   record         ; increase the record counter
    inc   oneblk         ; increase the one block counter
    ifgt  oneblk,#600    ; ? time to increase block counter
    jsr   addblk         ; jump to block increment routine

    ret                ; retrun to call sub rtn.

heading:
    ld    temp,#block    ; get adress of block pointer
    ld    a,[temp].b    ; load high byte of block counter
    jsr   chkopen        ; check whether the pin open now
    st    a,tbuf         ; xmit
    inc   temp           ; low byte address
    ld    a,[temp].b    ; load low byte of b.c.
    jsr   chkopen        ; check whether the pin open now
    st    a,tbuf         ; xmit

    ld    temp,#record  ; load record adress
    ld    a,[temp].b    ; load the high byte record counter
    jsr   chkopen        ; check whether the pin open now
    st    a,tbuf         ; xmit
    inc   temp           ; low byte address
    ld    a,[temp].b    ; load the low byte record counter
    jsr   chkopen        ; check whether the pin open now
    st    a,tbuf         ; xmit

    ret                ; return to calling routine

addblk:
    inc   block         ; increase the block counter
    ld    oneblk,#00    ; reset the one block counter
    ret                ; return to interrupt call routine

chkopen:
    ifbit 0,enu         ; check xmit port open
    ret                ; OK, it's open now
    jp    chkopen       ; check again

;-----
;               profilometer sampling routine
;-----

profsample:
    ld    profcnt,#000  ; initlz profile counter

addsample:

```

```

        sbit    7,portbl    ; do toggle high of KEY pulse
        nop     ; gives 1 micro-sec delay
        nop     ; gives another 1 micro-sec delay
        rbit    7,portbl    ; reset KEY pulse
        ld      t2,#00100   ; load T2 register for 200 micro-sec delay
        rbit    2,tmmode    ; start T2 clock
chk2:
        ifeq    t2,#00000   ; check underflow
        jp      first_RIA   ; generate the first RIA pulse
        jp      chk2_       ; do loop for checking t2 underflow

first_RIA:
        sbit    2,tmmode    ; stop T2 clock
        rbit    5,portbh    ; do toggle low of the 1st /RIA
        nop     ; give 1 micro-sec delay
        ld      bk,#profbuf,#profbuf+proflen-1 ; set start and end
        ; this instruction acts as a delay
        ; address of profilometer buffer
        sbit    5,portbh    ; reset 1st /RIA

docon:
        ifeq    intflag,#001 ; if Ch_B now
        jp      preCh_B     ; YES, do toggle lines for Ch B
        ld      portbh,#0fa  ; initlz /HIA, /HIB, /RIA and /RIB
        ;          low  high  high  high
        ;          B9   B10  B13   B14
        rbit    0,portpl    ; select ADC Ch1
        jp      seladc      ; jump to start sampling

preCh_B:
        ld      portbh,#0f9  ; set /HIA, /RIA and /RIB as high
        ; set /HIB as low
        sbit    0,portpl    ; select ADC Ch2

seladc:
        rbit    4,portph    ; get low /CS and /RD signals
        ; to begin sampling
        sbit    4,portph    ; complete one conversion process
        ld      a,0c000.b   ; read PSD porta bits (VOLTS)
        xs     a,[b+].b     ; store in the buffer
        jp      wait        ; NO, stay inner bound and go wait rtn.
        jp      onedone     ; sampling of profilometer done and jump
        ; to next step

wait:
        ifeq    intflag,#001 ; if int. flag indicates channel A
        jp      Ch_B        ; NO, select channel B rtn.
        rbit    6,portbh    ; get low reset signal of /RIB
        nop
        sbit    0,intflag    ; reset flag to select B channel next
        jmp     docon        ; next conversion

Ch_B:
        rbit    5,portbh    ; get low reset signal of /RIA
        nop
        rbit    0,intflag    ; reset flag to select A channel next
        jmp     docon        ; next conversion

onedone:
        inc     profcnt     ; increase profile counter
        ld      addpt,#profadd ; initlz addition pointer
        ld      bk,#profbuf,#profbuf+proflen-1 ; set start and end address
        ; one profile

addbin:

```

```

        lds    a,[b+].b          ; load stored value
        jmp    next_prof        ; jump to an next sampling

        add    a,[addpt].w      ; add current content
        inc    addpt            ; increase one word index
        jmp    addbin           ; do continue to add bins

next_prof:
        ifeq   profcnt,#008     ; if 8 profiles were sampled and added
        jmp    exsample        ; YES, jump to sample extra data sets

interval:
        ; -----time interval routine will be here-----
        jmp    addsample       ; jump to get one more profile

;=====
;          other transducers sampling routine
;          pressure, temperature, tilt, compass, OBS
;=====

exsample:
        ld     portpl,#010      ; set AD channel as Ch_3 for _pressure
        rbit   4,portph        ; get low /CS and /RD signals
        ; to begin sampling
        sbit   4,portph        ; complete one conversion process
        ld     a,0c000.b       ; read PSD porta bits (VOLTS)
        st     a,exbufptr      ; save reading
        inc    a,exbufptr      ; increase storing pointer by 1

        ld     portpl,#011      ; set AD channel as Ch_4 for _temperature
        rbit   4,portph        ; get low /CS and /RD signals
        ; to begin sampling
        sbit   4,portph        ; complete one conversion process
        ld     a,0c000.b       ; read PSD porta bits (VOLTS)
        st     a,exbufptr      ; save reading
        inc    a,exbufptr      ; increase storing pointer by 1

        ld     portpl,#100      ; set AD channel as Ch_5 for _tilt
        rbit   4,portph        ; get low /CS and /RD signals
        ; to begin sampling
        sbit   4,portph        ; complete one conversion process
        ld     a,0c000.b       ; read PSD porta bits (VOLTS)
        st     a,exbufptr      ; save reading
        inc    a,exbufptr      ; increase storing pointer by 1

        ld     portpl,#101      ; set AD channel as Ch_6 for _compass
        rbit   4,portph        ; get low /CS and /RD signals
        ; to begin sampling
        sbit   4,portph        ; complete one conversion process
        ld     a,0c000.b       ; read PSD porta bits (VOLTS)
        st     a,exbufptr      ; save reading
        inc    a,exbufptr      ; increase storing pointer by 1

        ld     portpl,#110      ; set AD channel as Ch_7 for _pressure
        rbit   4,portph        ; get low /CS and /RD signals
        ; to begin sampling
        sbit   4,portph        ; complete one conversion process
        ld     a,0c000.b       ; read PSD porta bits (VOLTS)
        st     a,exbufptr      ; save reading
        inc    a,exbufptr      ; increase storing pointer by 1

        ld     portpl,#111      ; set AD channel as Ch_8 for _open
        rbit   4,portph        ; get low /CS and /RD signals
        ; to begin sampling

```

```

        sbit    4,portph      ; complete one conversion process
        ld     a,0c000.b     ; read PSD porta bits (VOLTS)
        st     a,exbufptr    ; save reading
        inc   a,exbufptr    ; increase storing pointer by 1

        jmp    checkin      ; jump to get bass data interrupt

average:
                                ; ensemble averaging routine to caclulate
                                ; 32 times per second prof. data
        ld     padout,#profbuf ; set output buffer ptr.
        ld     bk,#profadd,#profadd+proflen*2-2 ; set clearing bounds

nextbin_avg:
        lds   a,[b+].w        ; load one bin prof datum
        ret                                ; limit passed,
                                ; return to send out rtn.
        shr  a                    ; divide by 2
        shr  a                    ; divide by 4
        shr  a                    ; divide by 8
        shr  a                    ; divide by 16
        shr  a                    ; divide by 32
        st   a,[padout].b      ; store one bin in output
                                ; buffer

; in above routine only low byte (LSB bits) will be stored in output buffer
; word to byte operation

        ld     a,padout        ; increse store pointer
        inc   a                ; increse one
        jp    nextbin_avg      ; do loop until finishing

.endsect
.end go
.end

```

## Serial Communications Prctocols

```
.title talk
; An interrupt subroutine for transmitting data
; Transmit from a circular buffer of size BUFLen
; Transmit only on -CTS (I4)

BUFLen = 128
WBUFLN = 64
THERM = 0X0200:WORD
TMMODE = 0X0190:WORD
DIVBY = 0X018E:WORD
T3 = 0X018C:WORD
R3 = 0X018A:WORD
PWMODE = 0X0150:WORD
TBUF = 0X0126:BYTE
RBUF = 0X0124:BYTE
ENUI = 0X0122:BYTE
BFUN = 0X00F4:WORD
DIRB = 0X00F2:WORD
PORTI = 0X00D8:BYTE
IRCD = 0X00D4:BYTE
ENIR = 0X00D0:BYTE
BUFTOP = 0X0010:WORD
BUFBOT = 0X0012:WORD

.sect C_STACK, RAM16, WORD
    .public STACK_start, STACK_end
STACK_start:
    .DSW 256
STACK_end:
    .public BUFP
BUFP:
    .DSW 1
    .public INBUF
INBUF:
    .DSW BUFLen
    .endsect
.sect TEST_MAIN, ROM16, WORD
UART_SEND:
; XMIT one byte via UART
    PUSH A
    PUSH X
; LD A, PORTI ; Sample CTS (I4)
; AND A.B, #H'10
; IFEQ A.B, #H'10 ; Clear & exit on high
; JMP CLR_TBMT
    LD X, BUFP.W ; Pointer to next byte to XMIT
    IFEQ X, #INBUF+BUFLen ; Wrap-around circular buffer
    LD X, #INBUF
    IFEQ X, BUFTOP ; More bytes to XMIT?
    JMP CLR_TBMT
    X A, [X+].B
    ST A, TBUF
    LD BUFP.W, X
    JMP US_END
CLR_TBMT:
    AND ENUI, #H'FE ; Clear XMIT interrupt
US_END:
    POP X
    POP A
    RETI
```

```

        .ipt      6,UART_SEND
CTS_OK: JSR      UART_SEND      ; Restart XMIT cycle when CTS goes low
        RET
        .ipt      4,CTS_OK
TEST_MAIN:
        LD      SP,#STACK_start
        LD      BUFP.W,#INBUF   ; Inbitialize buffer pointer
        LD      K.W,#INBUF+WBUFLN
        LD      TMODE,#H'4440   ; Stop timers T1 - T3
        NOP
        NOP                    ; Delay 8 cycles of CK2 clock
        LD      TMODE,#H'CCC8   ; Clear PND bits, T0 - T3
        LD      PWMODE,#H'4444  ; Same for T4 - T7
        NOP
        NOP                    ; Delay 8 cycles of CK2 clock
        LD      PWMODE,#H'CCCC  ;
        LD      BFUN,#H'0001    ; XMIT on B0 of PORTB
        LD      DIRB,#H'0001    ; It's an output
        LD      DIVBY,#H'201D   ; Set Order-of-Mag. for T3,T2,UART,Microwire
        LD      R3,#H'0006      ; 17 MHz/((6+1)x256) = 9487
        LD      T3,#H'0006      ; -1% error from 9600 Baud
        LD      TMODE,#H'0440   ; Start T3
; Set UART and CTS (I4) bits in ENIR register
; and ETI bit in the ENUI register.
; Clear XRCLK and XTCLK bits in the ENUI register.
        LD      ENUI,#H'C1      ; 2 stop bits, enable XMIT interrupt
        LD      IRCD,#0         ; Trigger interrupt on falling edge
        LD      BUFBOT,#INBUF   ; Initialize head and tail of circular queue
        LD      BUFTOP,#INBUF
        LD      ENIR,#H'51      ; Enable UART, I4 and global interrupts
;
; This section of the program would load data, and increment BUFTOP as it
; goes. Then, when transmission is allowed, it would enable interrupts
; and kick off the process by enabling interrupts and doing a JSRL
; (Jump to SubRoutine, Long) to UART_SEND. When it is time to collect more
; data, it disables interrupts, and so on. If you ever have to test the
; value of BUFBOT, be sure to disable interrupts (or at least the UART and
; CTS interrupts) first.
;
LOOP2:  LD      A,#0
LOOP1:  LD      B,#0              ; 100-count idle loop
LOOP3:  NOP
        NOP
        NOP
        NOP
        INC    B
        IFGT  B,#100
        JMP   NOLOOP3
        JMP   LOOP3
NOLOOP3:
        INC    A
        IFGT  A,#1000
        JMP   NOLOOP1
        JMP   LOOP1
NOLOOP1:
        AND   ENUI,#H'FE        ; Clear XMIT interrupt

```

```

        LD      B,#INBUF
        LD      A,#0
LOOP0:  ST      A,[B].B
        INC    B
        INC    A
        IFGT  A,#BUFLN
        JMP   NOLOOP0
        JMP   LOOP0
NOLOOP0: LD    BUFP.W,#INBUF
        LD    BUFTOP,#INBUF+WBUFLN
        OR    ENUI,#H'01      ; Enable XMIT interrupt
        JSRL UART_SEND
        JMP   LOOP2
        JMP   .
        .END  TEST_MAIN

```

```

        .title listen, 'A test program to simply listen to the BASS'
        ; and store data to memory
        ; Program sections:
        ; 1) Initialize HPC
        ; 2) Initialize timers
        ; 3) Initialize UART, including interrupts
        ; 4) Set memory buffer and loop 'til buffer full
        ; 5) Interrupt routine reads data
        ; and increments buffer pointer

BUFLen = 64
RBUF = 0x0124:byte
TMODE = 0x0190:word
PWMODE = 0x0150:word
BFUN = 0x00F4:word
DIRB = 0x00F2:word
DIVBY = 0x018E:word
R3 = 0x018A:word
T3 = 0x018C:word
ENUI = 0x0122:byte
ENIR = 0x00D0:byte

.sect C_STACK, RAM16, WORD
    .public STACK_start, STACK_end
STACK_start:
    .DSW 256
STACK_end:
    .public BUFP
BUFP:
    .DSW 1
    .public INBUF
INBUF:
    .DSW BUFLen
    .endsect

.sect TEST_MAIN, ROM16, WORD
UART_RCV:
    LD A, RBUF
    LD X, BUFP.W
    X A, [X+].B
    LD BUFP.W, X
    RETI
    .ipt 6, UART_RCV
;
TEST_MAIN:
    LD SP, #STACK_start
    LD TMODE, #H'4440 ; Stop timers T1 - T3
    NOP ; Delay 8 cycles of CK2 clock
    NOP
    LD TMODE, #H'CCC8 ; Clear PND bits (pending interrupts), T0 - T3
    LD PWMODE, #H'4444 ; Same for T4 - T7
    NOP ; Delay 8 cycles of CK2 clock
    NOP
    LD PWMODE, #H'CCCC
    LD BFUN, #H'0000 ; This program listens only
    LD DIRB, #H'0000 ; so clear TDX
    LD DIVBY, #H'201D ; Set Order-of-Magnitude for T3, T2, UART, Microwir
    LD R3, #H'0006 ; 17MHz/((6+1)x256) = 9487
    LD T3, #H'0006 ; ~1% error from 9600 Baud
    LD TMODE, #H'0440 ; Start T3
; Set UART bit and GIE bit in ENIR register.

```

```

; and ERI bit in the ENUI register. Clear XRCLK bit in the ENUI register.
LD      ENUI,#H'82      ; 2 stop bits, enable receive interrupt
LD      ENIR,#H'41     ; Enable UART interrupts
LD      BUFP.W,#INBUF  ; Initialize buffer pointer
LD      X,#INBUF       ; Base of input buffer
LOOP:   LD      ENIR,#H'41 ; Enable UART interrupts
NOP
NOP
NOP
NOP
NOP
LD      ENIR,#H'00     ; Disable UART interrupts
LD      A,#INBUF+BUFLN ; Check current buffer pointer
LD      X,BUFP.W
IFGT   A,X
JMP    LOOP
LD      ENUI,#H'00     ; Disable interrupts
LD      ENIR,#H'00
JMP    .
.END    TEST_MAIN

```

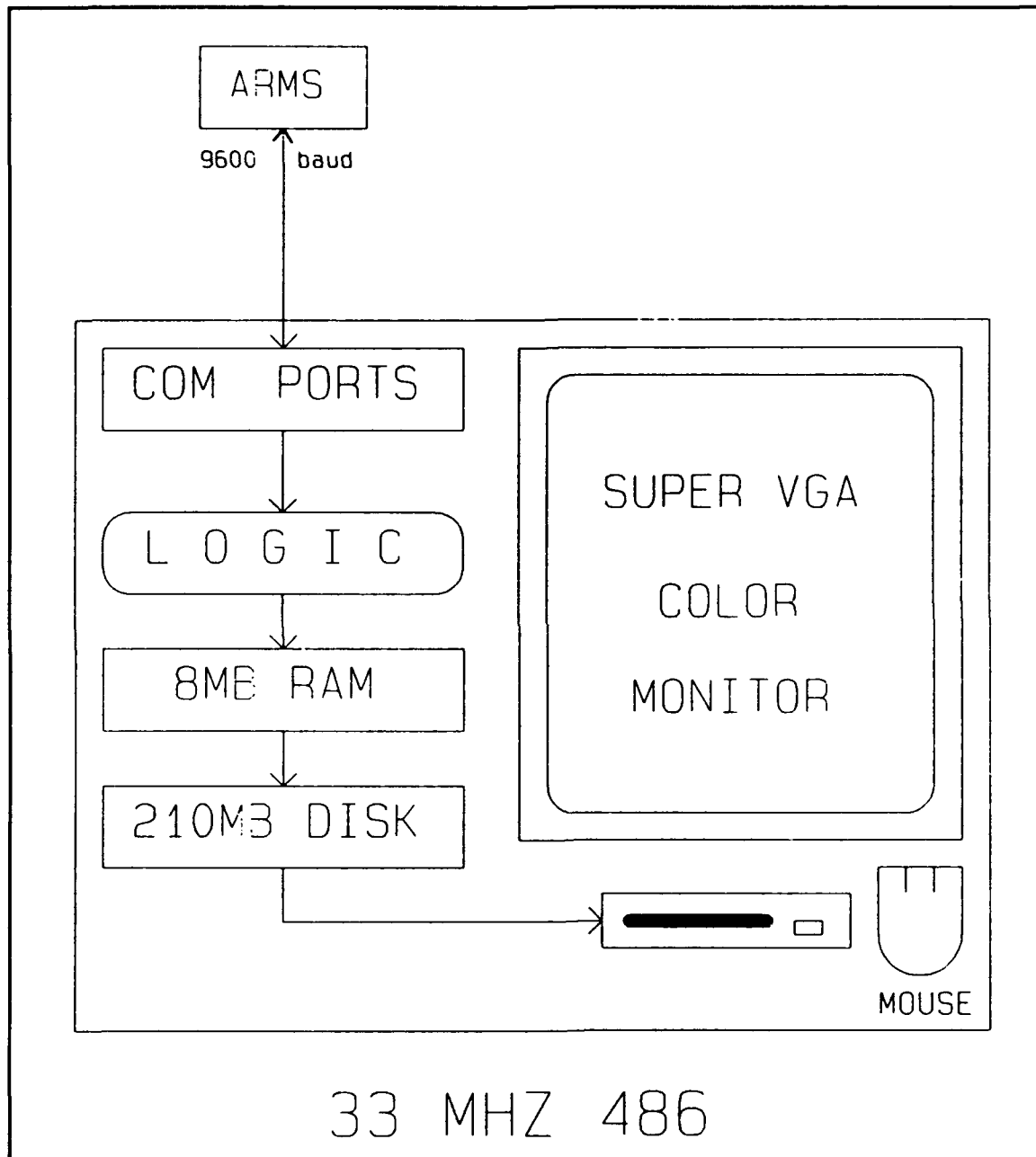

REPORT DOCUMENTATION PAGE			Form Approved OMB No. 0704-0188	
Public reporting burden for this collection of information is estimated to average 1 hour per response, including the time for reviewing instructions, searching existing data sources, gathering and maintaining the data needed, and completing and reviewing the collection of information. Send comments regarding this burden estimate or any other aspect of this collection of information, including suggestions for reducing this burden, to Washington Headquarters Services, Directorate for Information Operations and Reports, 1215 Jefferson Davis Highway, Suite 1204, Arlington, VA 22202-4302, and to the Office of Management and Budget, Paperwork Reduction Project (0704-0188), Washington, DC 20503.				
1. AGENCY USE ONLY (Leave blank)	2. REPORT DATE June 1994	3. REPORT TYPE AND DATES COVERED Final report		
4. TITLE AND SUBTITLE Acoustic Resuspension Measurement System (ARMS) Instrumentation Manual			5. FUNDING NUMBERS WV 32464	
6. AUTHOR(S) Robert E. Van Evra III, Keith W. Bedford				
7. PERFORMING ORGANIZATION NAME(S) AND ADDRESS(ES) Ohio State University 2070 Neil Avenue Columbus, OH 43210			8. PERFORMING ORGANIZATION REPORT NUMBER Contract Report DRP-94-2	
9. SPONSORING / MONITORING AGENCY NAME(S) AND ADDRESS(ES) U.S. Army Engineer Waterways Experiment Station Coastal Engineering Research Center 3909 Halls Ferry Road, Vicksburg, MS 39180-6199			10. SPONSORING / MONITORING AGENCY REPORT NUMBER	
11. SUPPLEMENTARY NOTES Available from National Technical Information Service, 5285 Port Royal Road, Springfield, VA 22161				
12a. DISTRIBUTION / AVAILABILITY STATEMENT Approved for public release; distribution is unlimited.			12b. DISTRIBUTION CODE	
13. ABSTRACT (Maximum 200 words)  This report describes the physical and electronic characteristics of an underwater instrument platform that is specifically designed to measure parameters associated with benthic boundary layer activity. The data-acquisition system is intended for use in studies of sediment resuspension and movement in the water column at existing and proposed dredged material placement sites. The system, ARMS, an acronym for <u>A</u> coustic <u>R</u> esuspension <u>M</u> easurement <u>S</u> ystem, can be deployed remotely at field sites from many vessels of opportunity. The ARMS utilizes technologically advanced underwater acoustic transducers to provide precise remote measurements of fluid and sediment motion. The local water column can thus be studied in an unobstructed state that preserves its naturally occurring hydrodynamic activity over small space and time scales. Other sensors collect information on sediment morphology, wave climate and seafloor orientation; thus, the system acquires data necessary to sufficiently reconstruct the boundary layer entrainment and bottom response characteristics. Such data may be used for site designation and monitoring or verification of environmental numerical simulation models.  <p style="text-align: right;">(Continued)</p>				
14. SUBJECT TERMS Boundary layer--Data processing Dredging spoil--Environmental aspects Sedimentation and deposition--Measurement-Instruments			Suspended sediments-- Environmental aspects	15. NUMBER OF PAGES 130
				16. PRICE CODE
17. SECURITY CLASSIFICATION OF REPORT UNCLASSIFIED	18. SECURITY CLASSIFICATION OF THIS PAGE UNCLASSIFIED	19. SECURITY CLASSIFICATION OF ABSTRACT	20. LIMITATION OF ABSTRACT	

### 13. ABSTRACT (Concluded).

The ARMS instruments and controlling circuitry are designed using high-speed and low-power integrated electronic components. Power and size efficiency enable the system to be contained in compact battery-supplied packages contained in relatively small pressure housings that mount unobtrusively on a portable bottom-standing tripod.

The ARMS is software-programmable using a personal computer to communicate directly with the system control circuitry. This operator interface allows field checking of instrument condition and performance. The control program parameters can be assigned to provide continuous, interval, or conditional operation of individual instruments, depending on desired sampling schemes. The digitized time series are stored on tape, to be loaded directly into minicomputers or workstations.