

AD-A283 595



①

NAMRL Special Report 91-2

DYNASIM: A SPATIAL  
DISORIENTATION RESEARCH TOOL

E. A. Molina, F. E. Guedry, and J. M. Lentz

DTIC  
ELECTE  
AUG 25 1994  
S G D

Naval Aerospace Medical Research Laboratory  
Naval Air Station  
Pensacola, Florida 32508-5700

Approved for public release; distribution unlimited

①

**NAVAL AEROSPACE MEDICAL RESEARCH LABORATORY  
NAVAL AIR STATION, PENSACOLA, FL 32508-5700**

**NAMRL Special Report 91-2**

**DYNASIM: A SPATIAL  
DISORIENTATION RESEARCH TOOL**

**E. A. Molina, F. E. Guedry, and J. M. Lentz**

Accession For	
NTIS CRA&I	<input checked="" type="checkbox"/>
DTIC TAB	<input type="checkbox"/>
Unannounced	<input type="checkbox"/>
Justification .....	
By .....	
Distribution /	
Availability Codes	
Dist	Avail and / or Special
A-1	

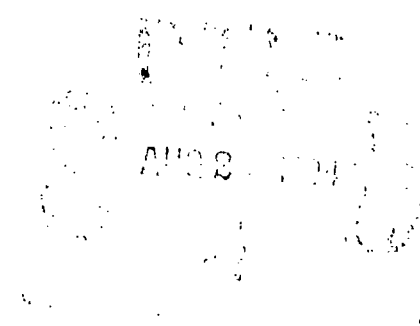

36p 94-26618  
406061



Approved for public release; distribution unlimited.

**94 8 22 01 6**

Reviewed and approved 9 August 1991

*J.A. Brady*

J. A. BRADY, CAPT, MSC USN  
Commanding Officer



This research was sponsored by the Naval Medical Research and Development Command under work unit 61703N MR00001.001-7037.

The views expressed in this article are those of the authors and do not reflect the official policy or position of the Department of the Navy, Department of Defense, or the U.S. Government.

Volunteer subjects were recruited, evaluated, and employed in accordance with the procedures specified in the Department of Defense Directive 3216.2 and Secretary of the Navy Instruction 3900.39 series. These instructions are based upon voluntary informed consent and meet or exceed the provisions of prevailing national and international guidelines.

Trade names of materials and/or products of commercial or nongovernment organizations are cited as needed for precision. These citations do not constitute official endorsement or approval of the use of such commercial materials and/or products.

Reproduction in whole or in part is permitted for any purpose of the United States Government.

# REPORT DOCUMENTATION PAGE

Form Approved  
OMB No. 0704-0188

Public reporting burden for this collection of information is estimated to average 1 hour per response, including the time for reviewing instructions, searching existing data sources, gathering and maintaining the data needed, and completing and reviewing the collection of information. Send comments regarding this burden estimate or any other aspect of this collection of information, including suggestions for reducing this burden, to Washington Headquarters Services, Directorate for Information Operations and Reports, 1215 Jefferson Davis Highway, Suite 1204, Arlington, VA 22202-4302, and to the Office of Management and Budget, Paperwork Reduction Project (0704-0188), Washington, DC 20503.

<b>1. AGENCY USE ONLY (Leave blank)</b>		<b>2. REPORT DATE</b> August 1991	<b>3. REPORT TYPE AND DATES COVERED</b> Final	
<b>4. TITLE AND SUBTITLE</b>  DYNASIM: A SPATIAL DISORIENTATION TOOL			<b>5. FUNDING NUMBERS</b>  61703N MR00001.001-7037	
<b>6. AUTHOR(S)</b>  E.A. Molina, F.E. Guedry, and J.M. Lentz				
<b>7. PERFORMING ORGANIZATION NAME(S) AND ADDRESS(ES)</b>  Naval Aerospace Medical Research Laboratory Bldg. 1953, Naval Air Station Pensacola, FL 32508-5700			<b>8. PERFORMING ORGANIZATION REPORT NUMBER</b>  NAMRL SR91-2	
<b>9. SPONSORING/MONITORING AGENCY NAME(S) AND ADDRESS(ES)</b>  Naval Medical Research and Development Command National Naval Medical Center, Bldg. 1 Bethesda, MD 20889-5044			<b>10. SPONSORING/MONITORING AGENCY REPORT NUMBER</b>	
<b>11. SUPPLEMENTARY NOTES</b>				
<b>12a. DISTRIBUTION / AVAILABILITY STATEMENT</b>  Approved for public release; distribution unlimited.			<b>12b. DISTRIBUTION CODE</b>	
<b>13. ABSTRACT (Maximum 200 words)</b>  The Dynasim can be used for research on the important problem of pilot disorientation. The facility consists of three main components: a motion system visual surround for presentation of Earth-fixed or moving targets, and a computer control system. The motion system is a short-arm centrifuge that provides yaw-axis rotation (at a maximum angular velocity of $\pm 150$ deg/s and angular acceleration of $\pm 15$ deg/s <sup>2</sup> ) of an off-center cockpit housed in an aircraft-like fuselage that moves about its own pitch and roll axes. The pitch and roll axes of the fuselage are closed-loop position feedback systems that can be controlled manually or by computer through $\pm 30$ deg. The fuselage can be oriented manually in four different headings: 0, 90, 180, and 270 deg relative to the center of rotation. The pitch and roll axes can be operated in a mode where the cockpit is kept aligned with the resultant linear acceleration vector for an angular range of 0-15 deg corresponding to an angular velocity of 0-90 deg/s. The computer system can present a variety of visual displays on two CRT scopes in the cockpit instrument panel. A Malcolm Horizon installed inside the cockpit displaying across the face of the panel can be used by the "pilot" to fly by instruments and counteract computer control of the motion device.				
<b>14. SUBJECT TERMS</b>  Naval aviation, Spatial disorientation, Pilot vertigo, Acceleration, Motion Device, Vestibular			<b>15. NUMBER OF PAGES</b> 36	
			<b>16. PRICE CODE</b>	
<b>17. SECURITY CLASSIFICATION OF REPORT</b> UNCLASSIFIED	<b>18. SECURITY CLASSIFICATION OF THIS PAGE</b> UNCLASSIFIED	<b>19. SECURITY CLASSIFICATION OF ABSTRACT</b> UNCLASSIFIED	<b>20. LIMITATION OF ABSTRACT</b> SAR	

## CONTENTS

ABSTRACT . . . . .	v
INTRODUCTION . . . . .	1
DYNASIM DESCRIPTION . . . . .	2
CHAMBER AREA . . . . .	2
VERTIFUGE . . . . .	3
Central Pedestal and Rotary Structure . . . . .	5
Fuselage and Cockpit . . . . .	8
Drive Systems and Performance Features . . . . .	8
Rotary Structure Main Drive System . . . . .	8
Base Platform Angular Positioning Drive Systems . . . . .	12
Base Platform Modes of Operation . . . . .	16
Slip Ring Assembly . . . . .	19
THE PROJECTED VISUAL DISPLAYS . . . . .	19
Overhead Projector System . . . . .	20
Onboard Projector System . . . . .	20
CONTROL ROOM AREA . . . . .	21
Control Room Layout . . . . .	21
Instrumentation Racks . . . . .	21
Operator's Control Console Rack . . . . .	24
DIGITAL CONTROLLER SYSTEM . . . . .	26
Onboard Computer System . . . . .	26
Control Room Computer . . . . .	26
SOFTWARE OPERATING SYSTEM . . . . .	27
Stimulus Function . . . . .	27
Response Function . . . . .	28
Storage Function . . . . .	28
Projector Functio . . . . .	28
UTC-PAB Functions . . . . .	28
Integrated Vertifuge Control Function . . . . .	28
OVERVIEW OF DYNASIM CAPABILITIES . . . . .	29
REFERENCES . . . . .	30

## ABSTRACT

The Dynasim is a facility for research on the important problem of pilot disorientation. The facility consists of three main components: a motion system, a visual surround for presentation of Earth-fixed or moving targets, and a computer control system. The motion system is a short-arm centrifuge that provides yaw-axis rotation of an off-center cockpit housed in an aircraft-like fuselage that is capable of motion about its own pitch and roll axes. For the yaw axis, maximum angular velocity is  $\pm 150$  deg/s, and nominal maximum angular acceleration is  $\pm 15$  deg/s<sup>2</sup>. Drive systems for the pitch and roll axes of the fuselage are closed-loop position feedback systems for controlling pitch and roll through  $\pm 30$  deg. The fuselage can be manually positioned in four different headings relative to the center of rotation (centripetal, centrifugal, and two tangential headings). The motion system can be controlled both, manually and under computer control via programmable function generators. The pitch and roll drive systems can be operated in a mode where the cockpit (tangentially or radially positioned) can be kept in continuous alignment with the resultant linear acceleration vector  $A_r = [1 + (W^2 * R / 32.2)^2]^{1/2}$  at an angle  $\tan^{-1}(W * R)$  for an angular displacement range of 0-15 deg, when the angular velocity changes from 0 to 90 deg/s.

The computer system provides capability for presenting a variety of visual displays on two scopes (cathode ray tubes) in the cockpit instrument panel. Currently available scope displays include an Attitude Direction Indicator (ADI) and five tests of cognitive performance. A functional Malcolm Horizon can also be displayed across the face of the panel. The main axis of the rotary device is centered in a 50-ft diameter white visual surround for presentation of patterns and targets external to the cockpit. Motion characteristics about pitch and roll axes and changes in visual displays (cockpit and external targets) are under computer control. In the cockpit, the "pilot" can fly by instruments and counteract computer control of the motion device. The computer provides immediate assessment of "man-in-the-loop" performance. This report describes structural features and capabilities of the Dynasim.

## Acknowledgments

The authors wish to acknowledge the following Naval Aerospace Medical Research Laboratory personnel: Dr. J. Grissett, Head Medical Sciences Department (during the period the Vertifuge was acquired) for his continuous support; Mr. W. Hixson for his contribution in acquisition of the Vertifuge Subsystem, engineering suggestions, and writing of the Dynasim Operation and Maintenance Instructions; Messrs. C. Lowery, E. Ricks, A. Dennis, and J. Sansing for their engineering technician support during the development of the device; Mr. T. Griner for the design of UTC-PAB test programs; and Messrs. J. Norman and G. Turnipseed for their technical assistance. Acknowledgment is also given to ensigns from the Schools Command for their technical assistance during documentation and testing, and Mr. S. Lacour, Naval Computer and Telecommunications Station, for Dynasim's Software System Design including programs used to calibrate and measure performance of both the radial and tangential angular position drive systems.

The authors also wish to acknowledge the typing and report layout skills of N. Davis and S. Dasho, and the editorial comments provided by K. Mayer.

## INTRODUCTION

Disorientation error accidents continue to be a major problem, resulting in the loss of student pilots, experienced pilots, and aircraft. The estimated cost of U.S. Navy Class A aircraft mishaps attributed to disorientation from 1974-1983 is \$0.5 billion and 100 pilots. In the U.S. Air Force, spatial disorientation was identified as a definite or contributing cause in 34% of USAF aircraft operator error mishaps over the 5-yr period 1980-1985 (1). In the Army Air Corps of the United Kingdom, 34% of all helicopter fatalities over a 16-yr period were attributed to disorientation (2). Pilot disorientation is also a significant contributor to mission failure in combat situations (3) and in peace-time patrol operations (4).

Efforts to reduce the disorientation problem should be directed along several lines including research on basic mechanisms of disorientation, research on disorientation demonstration scenarios for critical initial and follow-on training, research on idiosyncratic reactions to disorientation stress that increase the probability of control errors in operational settings, and research directed toward development of concepts for instrumentation, avionics packages and procedures for overcoming or avoiding disorientation. Each of these areas of research can be addressed by the facility described herein.

The facility designated as Dynasim was developed to augment our existing facilities for research on the important topic of disorientation. Dynasim consists of three main components: a motion system, a visual surround for presentation of Earth-fixed or moving targets, and a computer system. The motion system is a short-arm centrifuge that provides yaw-axis rotation of an off-center cockpit housed in an aircraft-like fuselage that is capable of motion about its own pitch and roll axes. The computer system provides capability for presenting a variety of visual displays on two scopes (cathode ray tubes) in the cockpit instrument panel. Currently available scope displays include an Attitude Direction Indicator (ADI) and five tests of cognitive performance. A functional Malcolm Horizon can also be displayed across the face of the panel. The main axis of the rotary device is centered in a 50-ft diameter white visual surround for presentation of patterns and targets external to the cockpit. Motion characteristics about pitch and roll axes and changes in visual displays (cockpit and external targets) are under computer control. In the cockpit, the "pilot" can fly by instruments and counteract computer control of the motion device. The computer provides immediate assessment of "man-in-the-loop" performance. The main body of this report provides a description of the major components and subsystems of Dynasim and their structural and operational characteristics.

## DYNASIM DESCRIPTION

All components, instrumentation, and computers that comprise Dynasim are contained within the chamber area and the control room area. Figure 1 is an artist's sketch of Dynasim, showing the motion system, the circular chamber area, and the control room area.

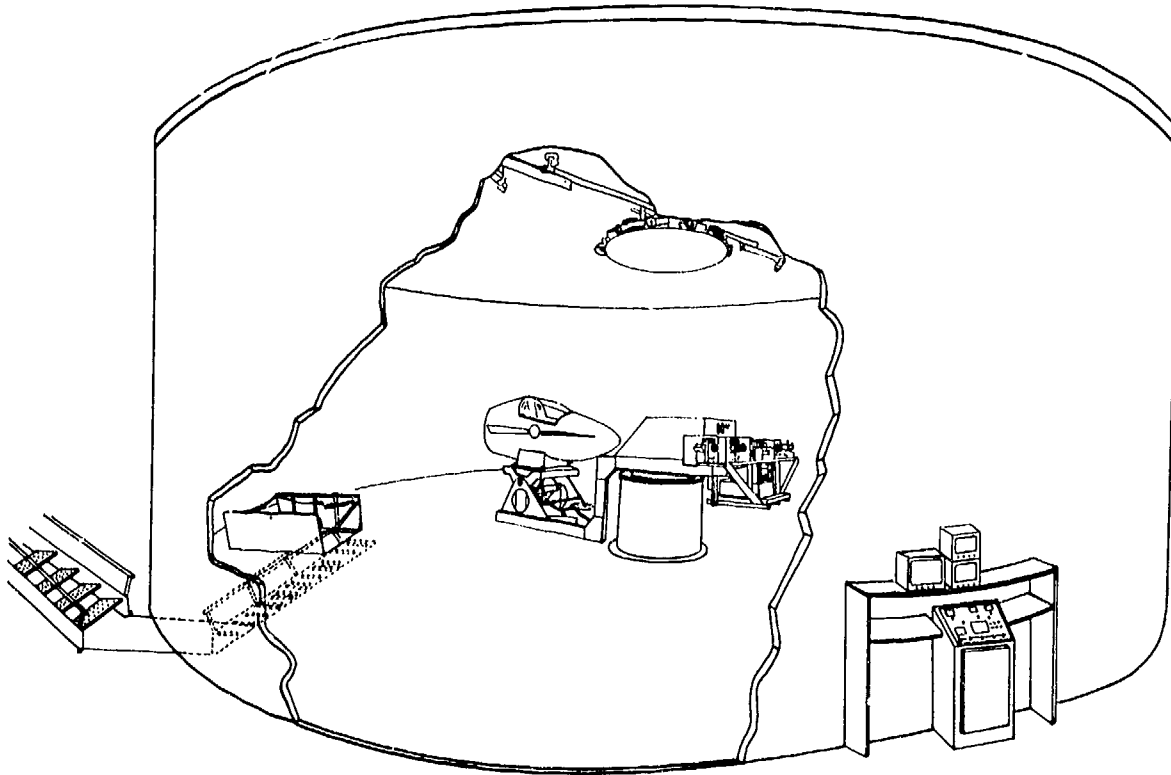
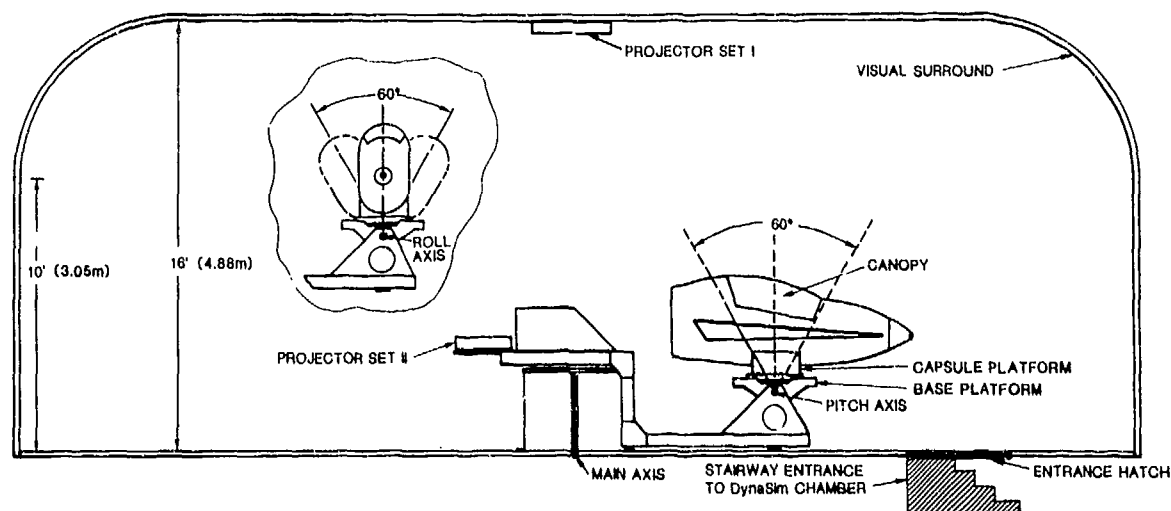

**Figure 1.** Artist's sketch of Dynasim depicting the Vertifuge fuselage (in centripetal configuration), circular surround, entrance, control console, "onboard" projectors, overhead projectors, and video cameras suspended from overhead arms.

### CHAMBER AREA

The chamber is a cylindrical room 15.24 m in diameter and 4.88 m in height. The wall, ceiling, and floor are painted white so as to approximate a surrounding homogeneous visual field. Entrance to the chamber is possible only through the access door located in the floor at a distance of 4.47 m from the center of the room. Heavy-duty switches on the frame of the access door

are wired to indicate the open/close status of the door at the control console in the control room. A cross-sectional sketch of the chamber is shown in Fig. 2.

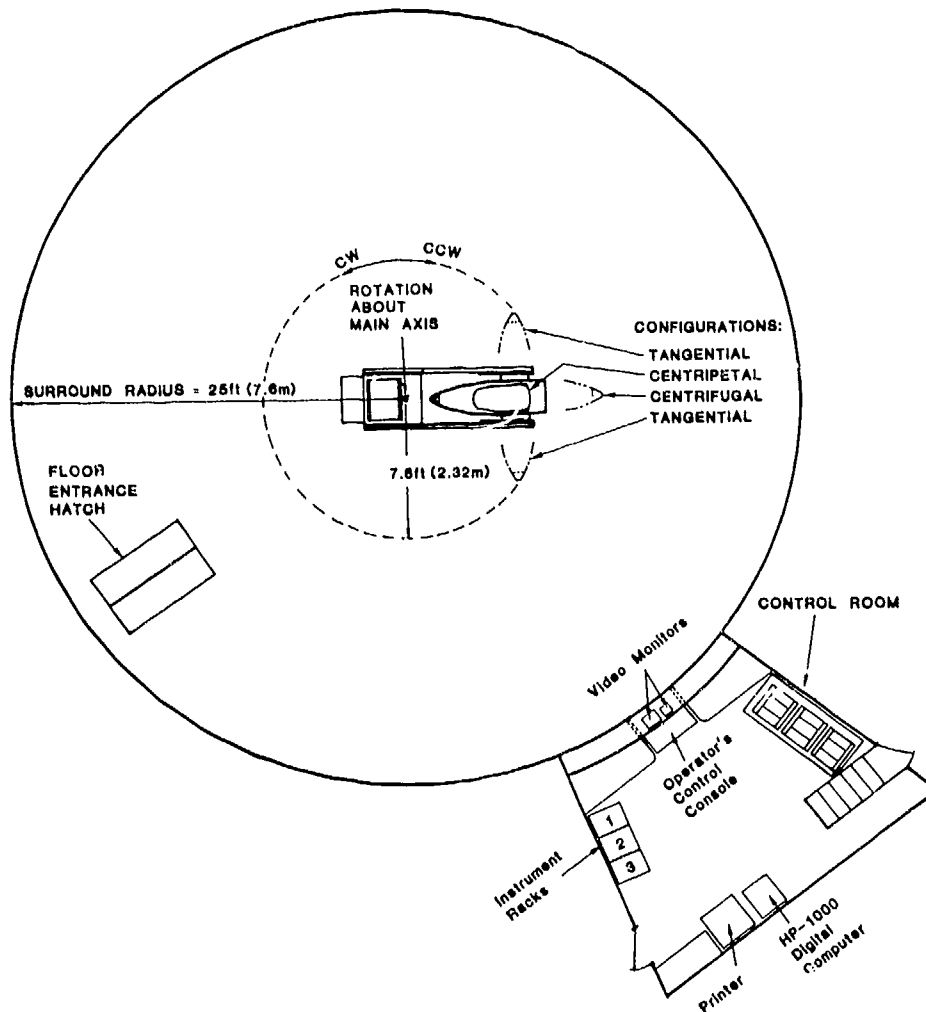

**Figure 2.** Elevation sketch showing chamber, Vertifuge fuselage (in centrifugal configuration), Projector Set I (overhead projectors), Projector Set II (onboard projectors) and entrance way.

The chamber houses the Vertifuge, a three-axis motion system, and two sets of projectors. The overhead projector set (Set I in Fig. 2) can project Earth-fixed scenes and patterns onto the visual surround. The "on board" projector Set (Set II, Fig. 2) can project targets at different angular displacements relative to the subject in the cockpit of the Vertifuge. All audio/visual equipment needed for communication between control room operators and the human subject in the Vertifuge cockpit and for visual monitoring of the chamber area and the subject in the cockpit is contained within the chamber, the Vertifuge, and the control room. A plan view of the chamber, the Vertifuge, and the control room is presented in Fig. 3.

## VERTIFUGE

Our Model 2200 Vertifuge, manufactured by Emro Engineering Company, is firmly secured (by eight 2.54-cm anchor bolts) to the floor and leveled so that its main axis is vertical and centered in the circular chamber area. Overall weight of the Vertifuge is 1000 kg.



**Figure 3.** Plan view sketch illustrating the control room area, chamber area, and the four possible configurations of the Vertifuge.

Essentially, the Vertifuge is a centrifuge designed to rotate a human subject seated in a cockpit at a mean radius of 2.32 m about an Earth-vertical main axis. The cockpit is housed in an aircraft-like fuselage that is mounted above two orthogonal axes of its own, one above the other. The lower axis is tangentially aligned and carries the housing for the bearings of the upper axis, which is radially aligned. These stacked axes allow independent or simultaneous pitch and roll of the fuselage through  $\pm 30$  deg from the upright cockpit position. When the fuselage is in the centripetal configuration (Fig. 3), the lower axis provides the pitch movement of the fuselage. When the Vertifuge is in the tangential configuration (Fig. 3), the upper

axis allows pitch movement of the fuselage. Because the subject's head is located considerably above these axes, the radial displacement of the head from the main axis varies during either pitch or roll of the fuselage.

The fuselage is mounted on top of a 91.44- by 83.82-cm platform that is coupled via a bearing and latching pins to a second platform (base platform) of the same dimensions. The fuselage and its platform must be positioned manually with respect to the base platform to achieve the four different configurations shown in Fig. 3. Once a particular configuration has been selected, the fuselage and supporting platform are secured to the base platform by means of four spring-loaded latching pins.

Our Vertifuge is equipped with three interchangeable canopies for pursuit of different procedural objectives. An opaque canopy blocks out external light and restricts the subject's vision to the cockpit interior. A translucent canopy transmits external light but obscures the subject's view of external visual detail. A clear canopy provides the subject relatively unrestricted view of the external visual surround.

#### Central Pedestal and Rotary Structure

Two major components of the Vertifuge are the center supporting pedestal and the rotary structure. The center pedestal is a cylindrical hollow structure, 132 cm in diameter and 86.36 cm in height, which houses the main bearing for the rotary structure as well as the reduction gear and motor to drive the rotary structure.

Two radial arms extend out from the center of the rotary structure, one long radial arm and an antipodal short radial arm. The long arm supports the fuselage with its underlying orthogonal pitch and roll axes and attachments to hydraulic servoactuators that position the fuselage about its pitch and roll axes. The central rotary structure contains the hydraulic power source for the pitch and roll servoactuators (including hydraulic pump, reservoir tank, ac motor powering the pump and hydraulic circuitry), slip-ring assembly, and analog instrumentation circuitry. The short radial arm of the rotary structure supports an onboard HP-1000 digital computer/controller, a random projector set (set II Fig. 2) and an interface to the onboard HP-1000 computer, and a 60-400 Hz frequency converter power supply.

The center pedestal and rotating arm structure are shown in Figs. 4a and 4b. Figures 5 and 6 show the pitch and roll servoactuators.

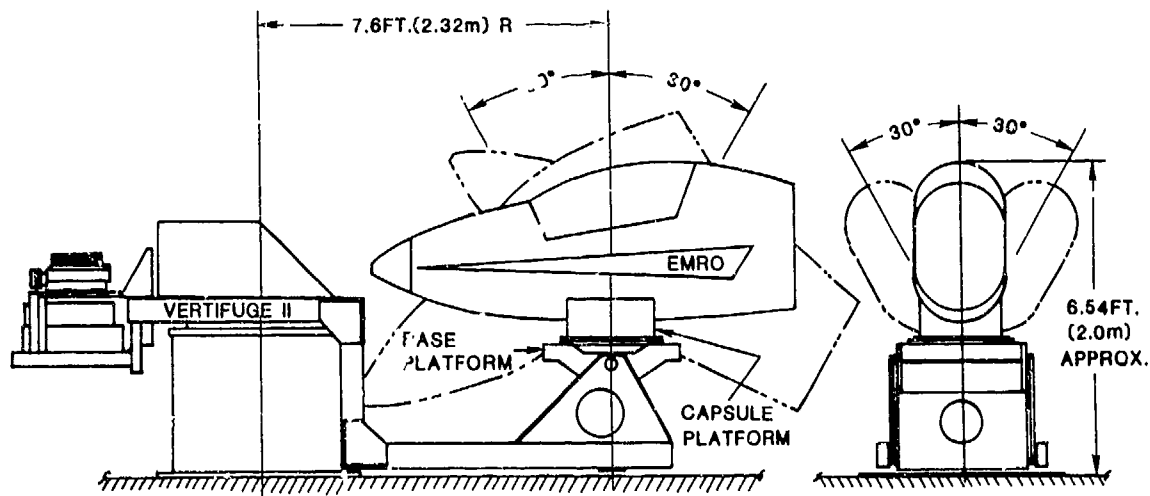

**Figure 4a.** *The center pedestal, the long and short radial arms, and the pitch and roll limits.*

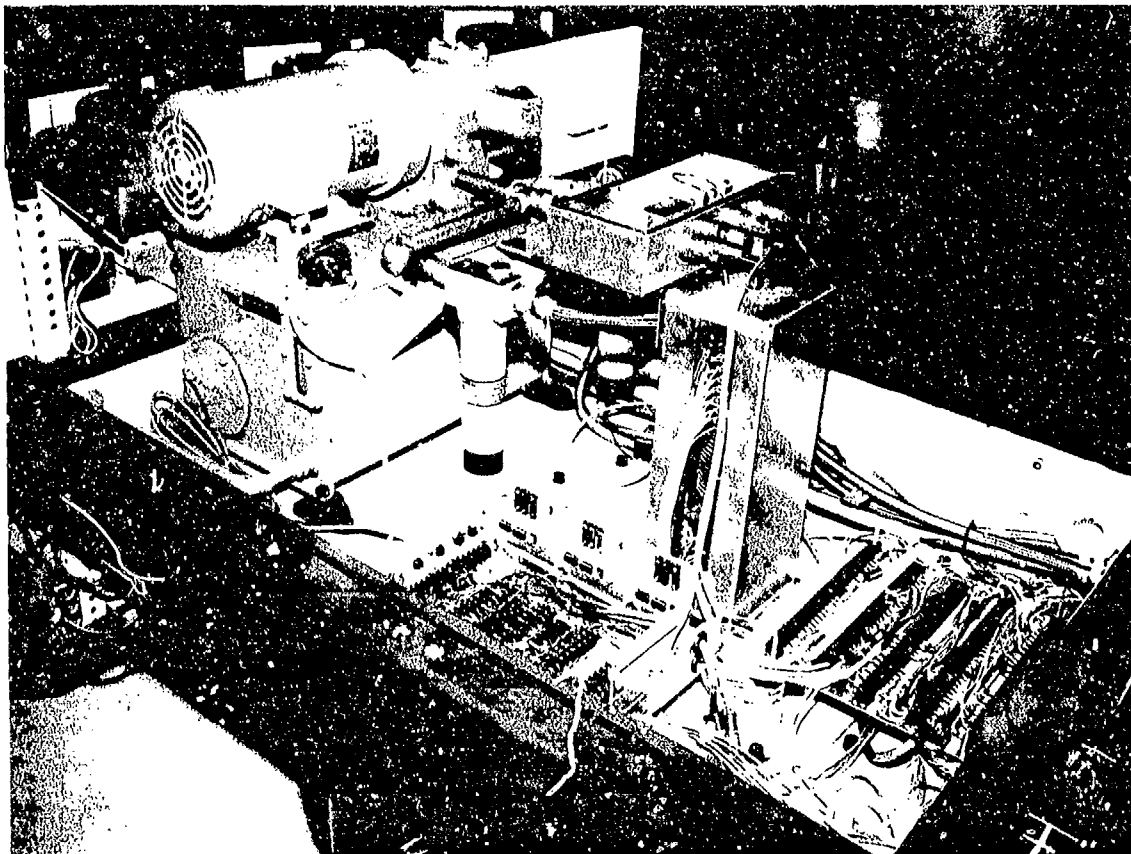

**Figure 4b.** *The central rotary structure showing the hydraulic pump, reservoir tank, ac motor powering the pump, hydraulic lines, slip-ring assembly, and analog instrumentation mounting.*

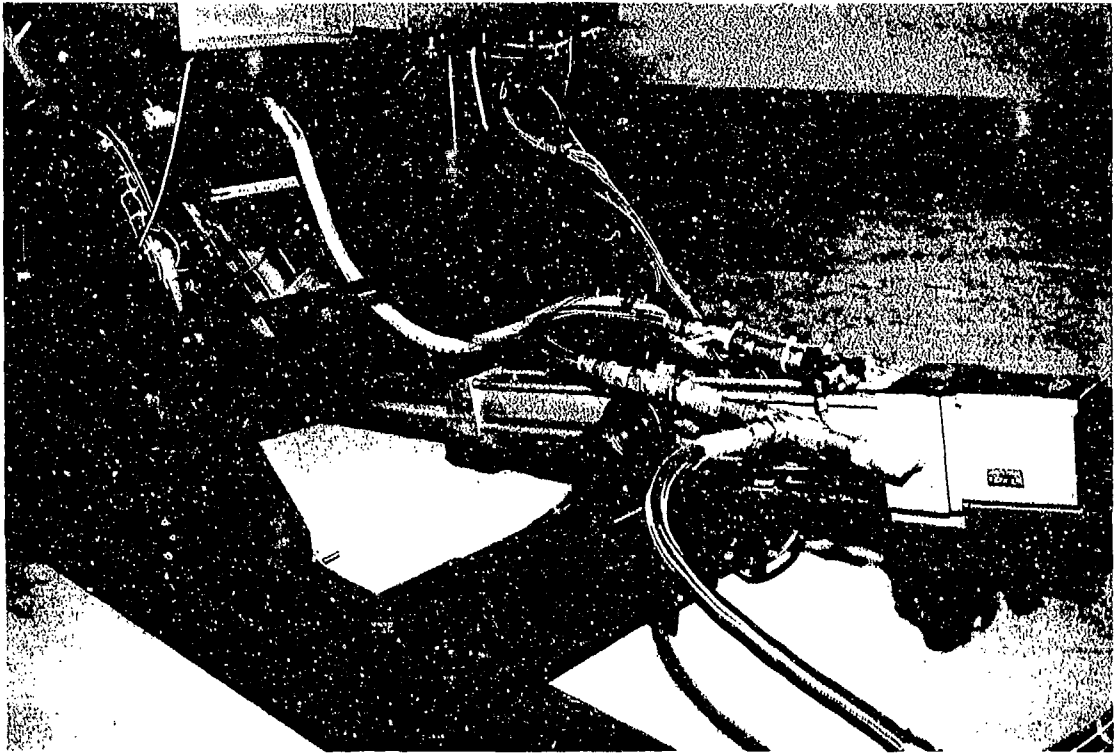

**Figure 5.** *Photograph showing the radially mounted servoactuator for the tangential axis.*

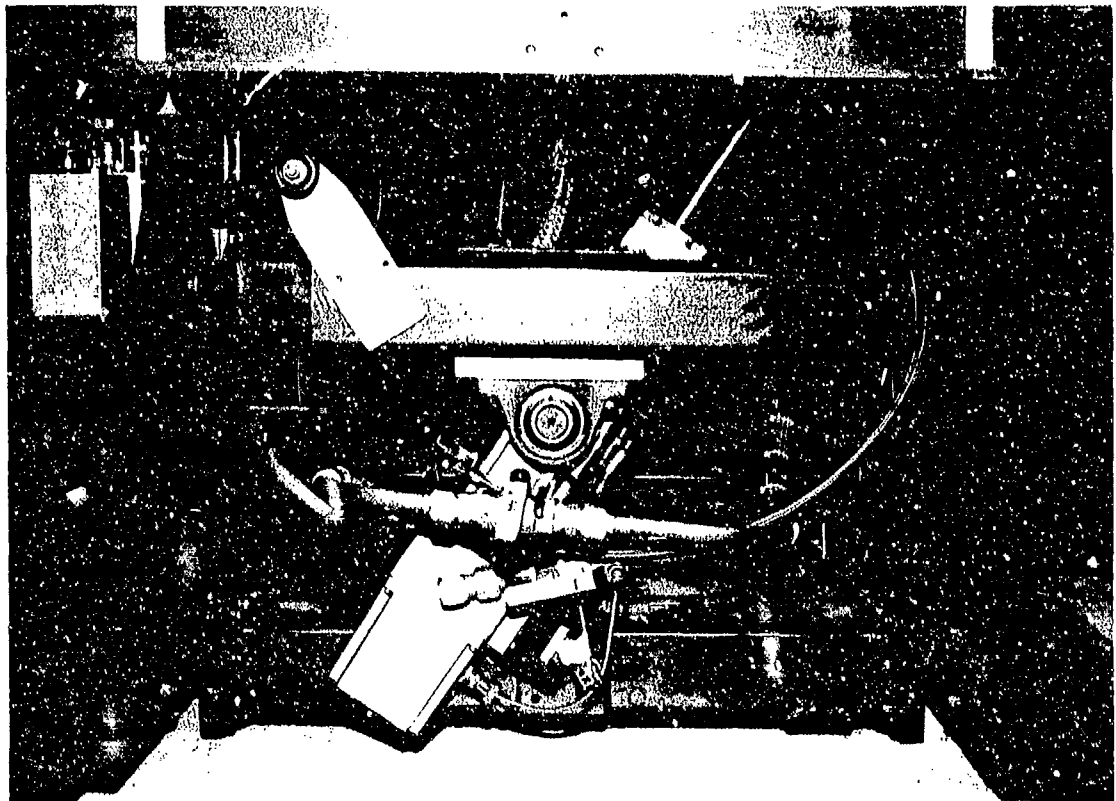

**Figure 6.** *Photograph showing the tangentially mounted servoactuator for the radial axis.*

## Fuselage and Cockpit

The fuselage contains the cockpit (enclosed by interchangeable canopies), a ventilation fan in the forward fuselage, and in the after end, an electronic controller for the Malcolm Horizon, an HP-IB extender interface, terminal boards for interconnecting wiring, and a triple output voltage (+5.00 VDC, +/-15 VDC) power supply for the HP cathode ray tubes (HP CRTs) in the cockpit instrument panel.

The cockpit consists of the subject's seat, control devices, and an instrument panel. Two HP CRTs are installed in the instrument panel.

These are interfaced with the onboard HP-1000 computer for presentation of visual tasks and simulated aircraft instruments. A functional Malcolm Horizon to indicate attitude relative to the horizon can be projected onto the face of the instrument panel. A two-axis joystick provides control of pitch and roll by the human subject.

Rudder pedals and an engine throttle control are not instrumented at present. The subject's seat has a suitably adjustable safety harness. Two video cameras in the cockpit provide control room monitoring of the subject and the instrument panel. Figures 7-9 are photographs of the interior of the cockpit.

## Drive Systems and Performance Features

The Vertifuge has three electromechanically independent drive systems. The main drive for the rotary structure is a dc motor. Two hydraulic drive systems accomplish pitch and roll positioning of the fuselage base platform: the radial-axis angular position drive system and the tangential-axis angular position drive system.

### Rotary Structure Main Drive System

The drive is a rate servo control system. An adjustable speed motor controller by The Vee-Arc Corporation powers a shunt wound dc motor. These have the following operating electrical/mechanical specifications:

Adjustable speed controller:	Model RIVCS-2HP	
Armature supply voltage range, V		0-120
Armature supply current range, A		0-14
Field supply voltage, V		105
Field supply current, A		0.803

DC Motor: Model 5BC79AB544  
Speed range, rpm  
Mechanical rotating power, hp

0-2000  
2.0

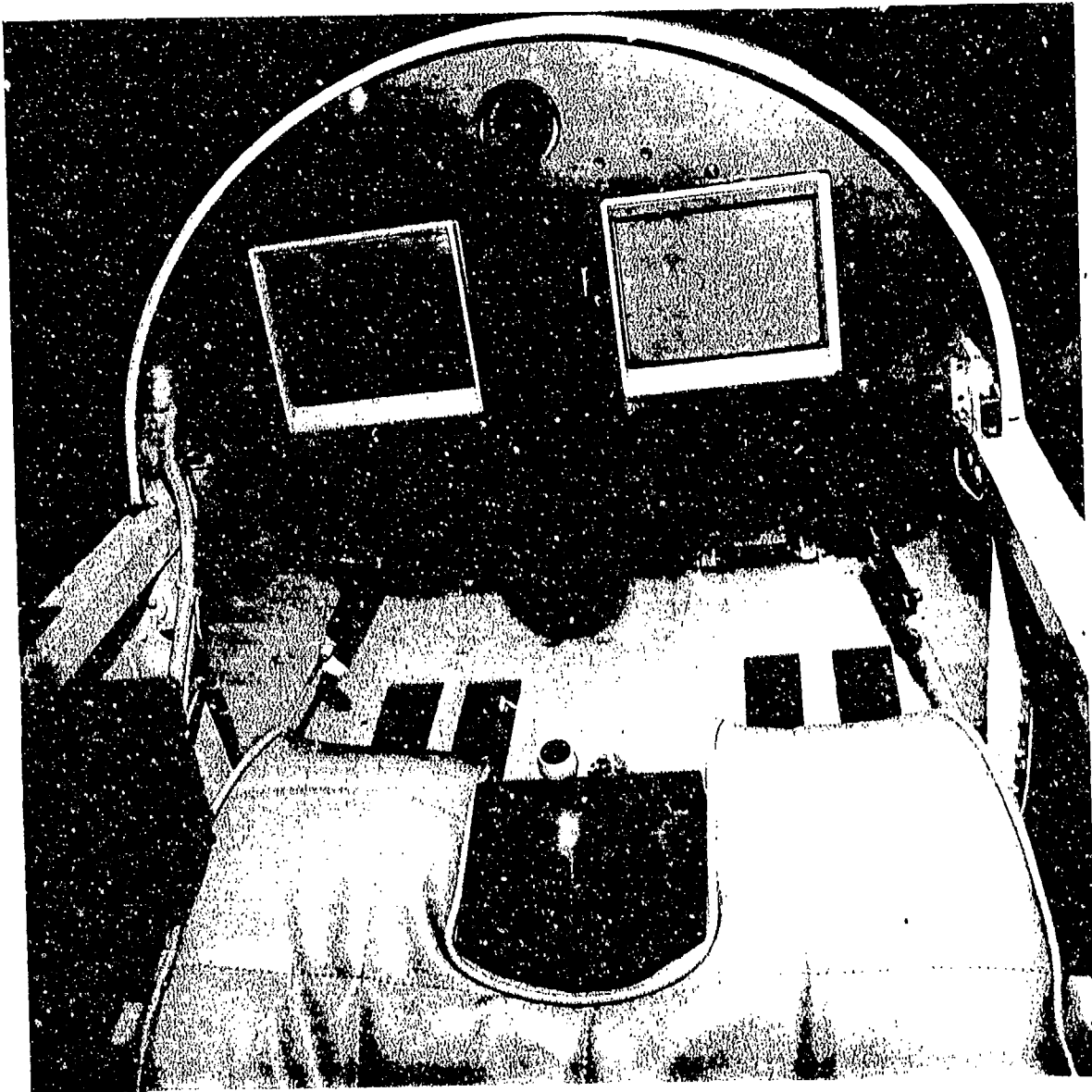

**Figure 7.** Photograph showing the cockpit instrument panel (with two CRT apertures and video camera for viewing the subject), rudder pedals, joystick, and engine throttle control.

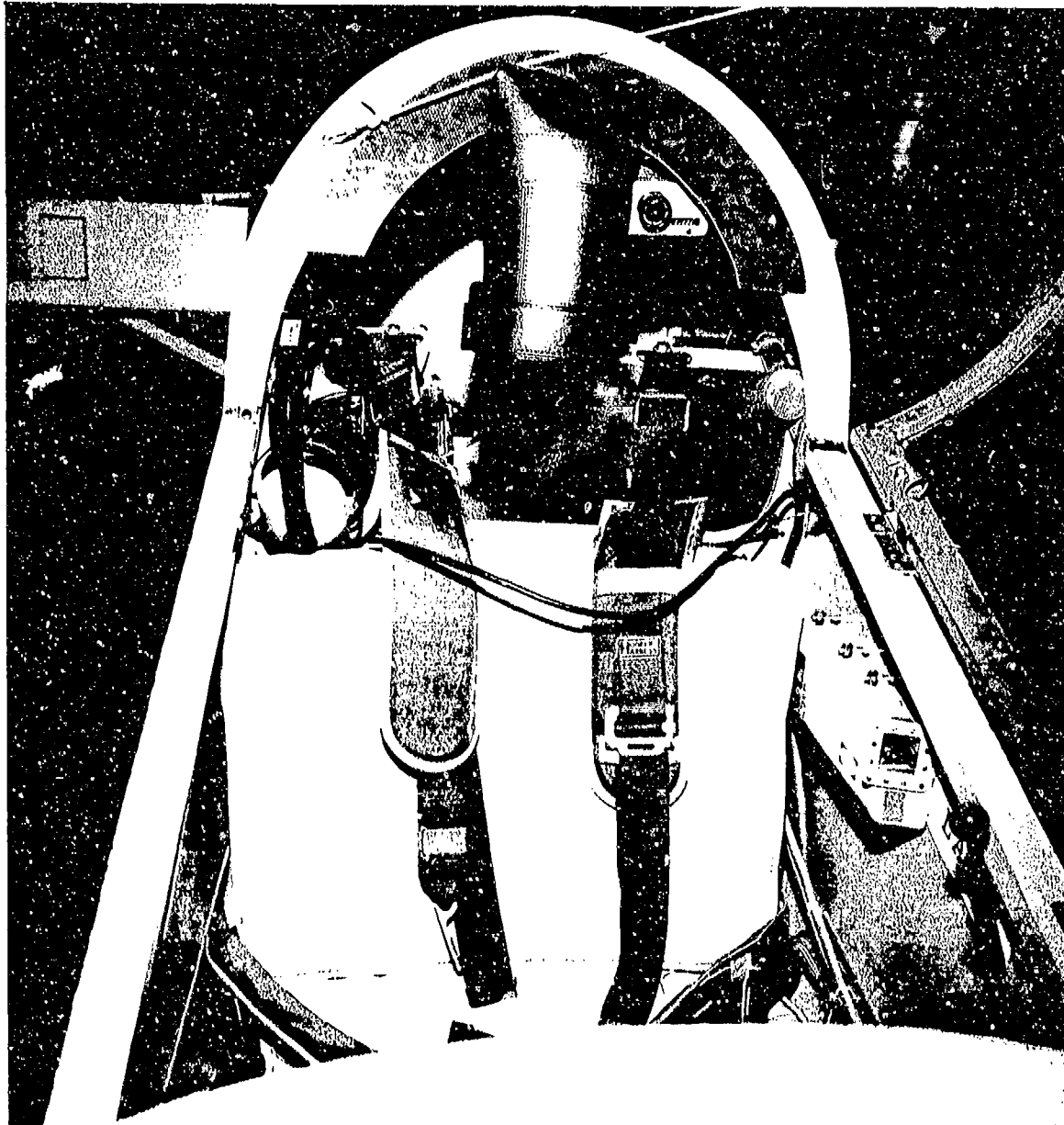

**Figure 8.** Photograph showing the subject seat and head rest, restraint system, video camera to view instrument panel, and the laser projector system for the Malcolm Horizon.

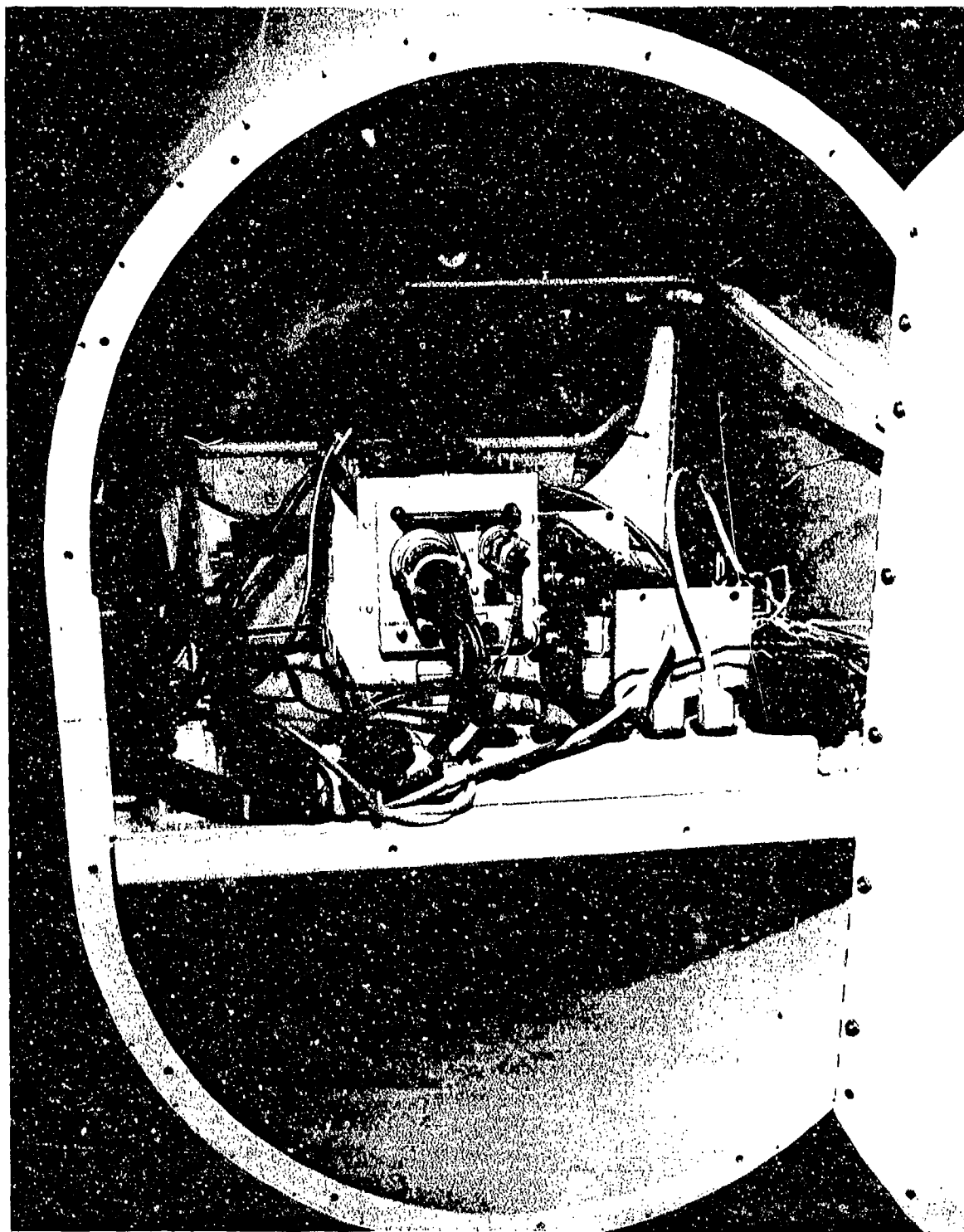

**Figure 9.** *Photograph showing rear fuselage interior containing the Malcolm Horizon processor and power supplies.*

The dc motor, electrically connected as a separately excited dc motor, is mechanically coupled to the rotary structure through an 80:1 gear mechanism. This provides a range of selectable speeds of the main rotary structure from 0 to 25 rpm (150 deg/s). Empirical tests indicate that the maximum mean angular acceleration in attaining selected constant angular speeds is 9.6 deg/s<sup>2</sup> and maximum mean angular acceleration in stopping is 25.6 deg/s<sup>2</sup>. At 2.32 m (the approximate radial distance of a subject's head) and 25 rpm, the centripetal acceleration is 1.62 g, but man-rating of the device limits centripetal acceleration to 1.25 g, which limits maximum angular speed to 2.299 rad/s (21.95 rpm). The drive system, including subject and equipment, is rated for a maximum payload of 638 kg.

### Base Platform Angular Positioning Drive Systems

Pitch and roll positioning of the base platform of the fuselage is achieved by A86 Series Linear Servoactuators from Moog, Incorporated. Each servoactuator consists of a high performance cylinder, servovalve, and transducer assembly built into one unit. The units are designed to minimize fluid compliance of the cylinder lines which gives the highest drive resonant frequency. The integral nature of the A86 series servoactuators eliminates hydraulic manifolds, plumbing between the servovalve and cylinder, transducer mounting brackets, and other mechanical couplings. A position transducer is internally mounted and coaxially connected to eliminate backlash and damage during installation or use.

Each of the linear servoactuators used to tilt the base platform of the fuselage is electrically powered and controlled by an electronics servocontroller connected as a closed-loop position feedback system. The servo electronic controllers are mounted inside the operator's control console as shown in Fig. 10.

Both linear servoactuators have hydraulic power supplied from the hydraulic power source located centrally on the rotary structure. The output hydraulic power supply rating is:

Flow rate, L/min	20
Hydraulic pressure, kg/cm <sup>2</sup>	1759.53

Both the radial and tangential A86 linear servoactuators have the following common operating characteristics:

Bore size, cm	6.35
Piston area, rod end, cm	6.35
Piston area, head area, cm <sup>2</sup>	12.446

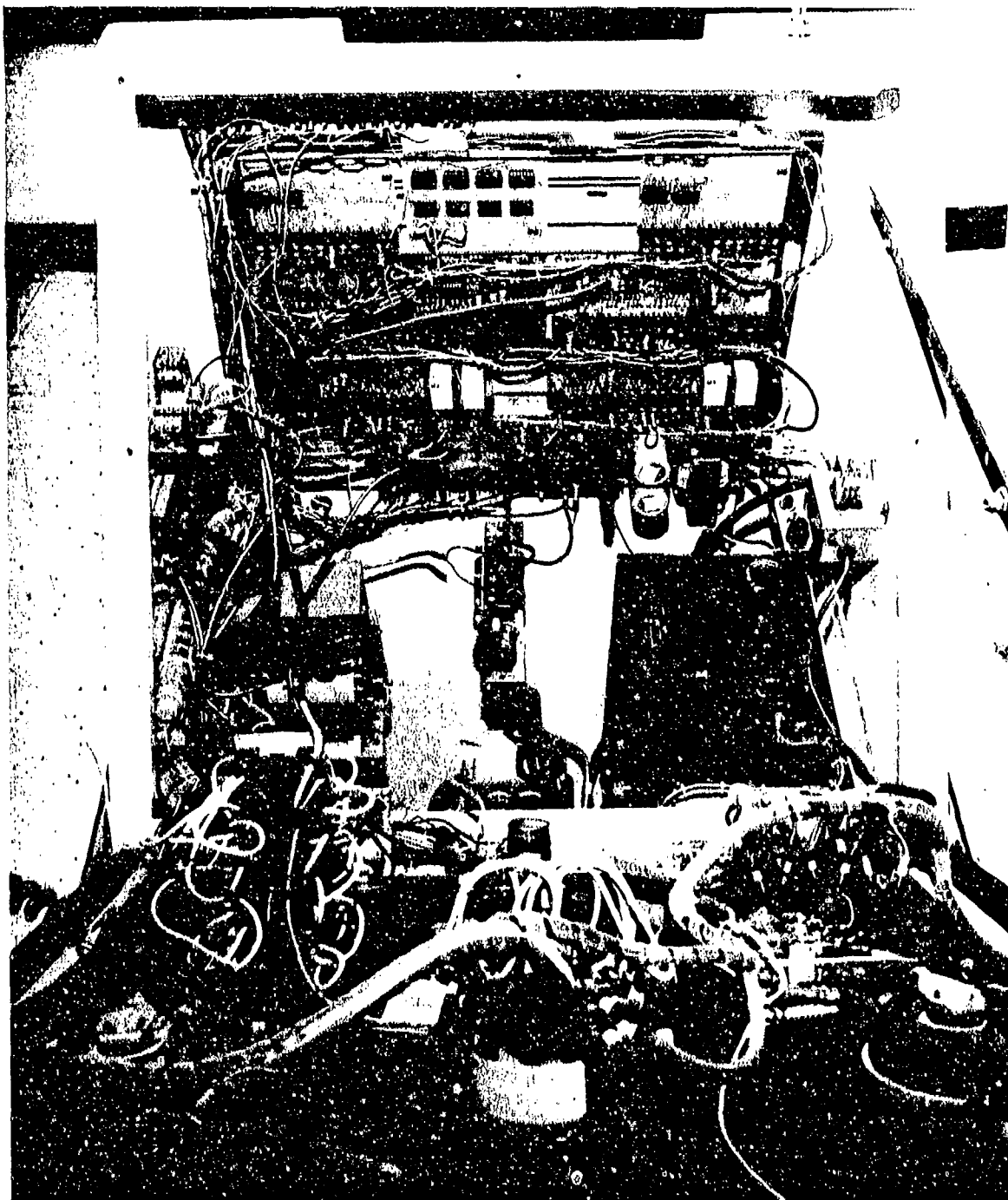

**Figure 10.**

*Photograph of the mounting of the servo electronic controllers inside the operator's control console.*

For a rated pressure of 5865.09 kg/cm<sup>2</sup>:

Maximum stall force	
Fully extended, kg	4454.55
Fully retracted, kg	2272.73
Maximum piston friction, kg	545.45

Mounting installation	midtrunion
-----------------------	------------

Servo valve model:	760-103
--------------------	---------

Rated flow at 1000 psi, L/min	20
Maximum no-load velocity	
Extension, cm/s	35.02
Retraction, cm/s	23.11
First-order time constant, s	0.0037

Positioning of the fuselage base platform about its tangential axis is achieved by the radially mounted A86 Linear Servoactuator having a maximum stroke length of 60.96 cm. Stroke lengths of 0, 30.48, and 60.96 cm correspond respectively to -30, 0, and +30 deg tilt of the base platform. Maximum tilt speeds in degrees/second are given in Table 1.

Positioning of the base platform about the radial axis is achieved by the tangentially mounted A86 Linear Servoactuator, which has a maximum stroke length of 30.48 cm. Stroke lengths of 0, 15.24, and 30.48 cm correspond respectively to -30, 0, and +30 deg tilt of the base platform. Maximum tilt speeds in degrees/second are given in Table 1.

As shown earlier in Fig. 3, the fuselage platform can be positioned with respect to the base platform in four different orientations or configurations. Table 2 shows the tangential and radial hydraulic servoactuators driving the fuselage platform about its pitch or roll axis according to the orientation of the fuselage platform with respect to the base platform.

**TABLE 1.** Radial, Tangential Maximum Angular Velocity as a Function of Command Angular Position.

Angular position (degrees)	Maximum angular velocity $W_{max}$ deg/s	
	Radial	Tangential
5.00	1.54	0.92
10.00	2.44	2.26
15.00	3.33	3.60
20.00	4.23	4.93
25.00	5.13	6.27
30.00	6.03	7.61
- 5.00	-0.25	-1.75
- 10.00	-1.15	-3.09
- 15.00	-2.05	-4.43
- 20.00	-2.94	-5.77
- 25.00	-3.84	-7.10
- 30.00	-4.74	-8.44

**TABLE 2.** Selection of Radial and Tangential Servoactuator as Pitch or Roll Mechanical Positioners when Fuselage Orientation Changes with Respect to the Base Platform.

FUSELAGE		
Orientation	Pitch	Roll
0 Centripetal	radial	tangential
90 Tangential	tangential	radial
180 Centrifugal	radial	tangential
270 Tangential	tangential	radial

## Base Platform Modes of Operation

Operation of the cockpit platform can be performed in any of the following modes and their combinations:

- Operator control of fuselage attitude.
- Subject control of fuselage attitude.
- Automatic alignment with resultant acceleration vector.
- Remote programmed control of fuselage attitude.

Operator and subject control of the fuselage pitch and roll positioning is achieved by joysticks in the operator's control console and inside the fuselage cabin, respectively. A switch in the operator's control console enables or disables the onboard joystick.

In the automatic alignment with resultant acceleration vector mode, the radial positioning drive system uses the electrical output signal from the inclinometer (forced-balanced linear accelerometer) mounted in the radial base platform to align the platform perpendicular to the resultant linear acceleration vector. The amplitude of resultant linear acceleration vector, and the angle it sustains with respect to the vertical axes, is a function of the rotary's angular velocity:

$$A_r = [ 1 + (W^2 * R / 32.2)^2 ]^{1/2} \quad \text{amplitude in g's}$$

$$\text{Angle} = \tan^{-1}(W^2 * R / 32.2) \quad \text{degrees.}$$

Because the angular displacement (rolling or pitching depending on the orientation of the capsule) of the radial system is only  $\pm 30.00$  deg, the maximum angular velocity range for which this mode is operational is 0 through 15 rpm (90.00 deg/s).

Remote programming control of the fuselage pitch and roll positioning is achieved by Wavetek programmable waveform generators under control of the HP-1000 digital computer controller. The following waveform positioning profiles can be used to control the pitch and roll motion:

- Sine wave
- Triangular wave
- Square wave
- Any complex wave stored (2048 point values).

Recorded tracings of base platform positioning about the tangentially and radially oriented axes for a given step command and a sinusoidal command are shown in Figs. 11 and 12.

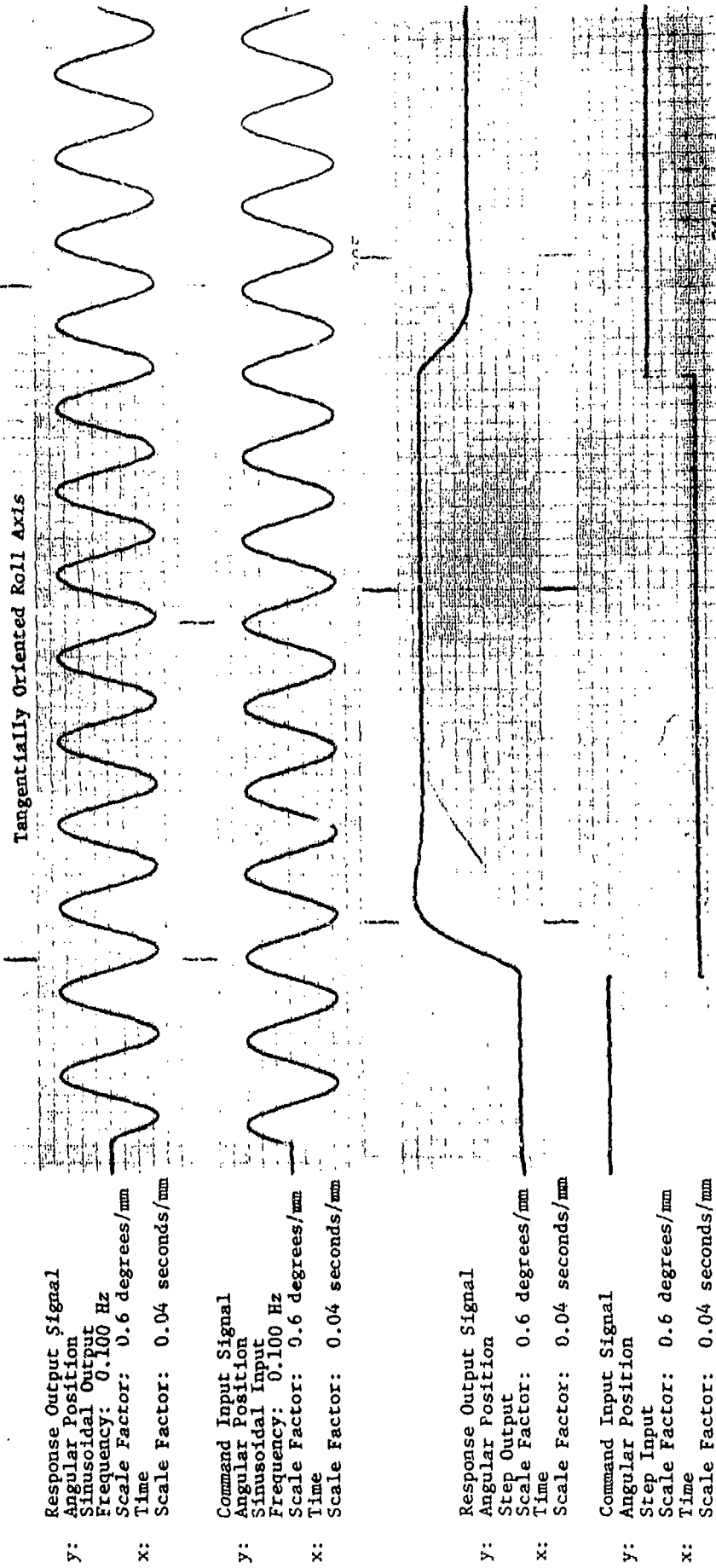

Figure 11. Recorded input/output tracings for the tangentially oriented axis.

Radially Oriented Pitch Axis

Response Output Signal  
y: Angular Position  
Step Output  
Scale Factor: 0.6 degrees/mm  
x: Time  
Scale Factor: 0.04 seconds/mm

Command Input Signal  
y: Angular Position  
Step Input  
Scale Factor: 0.6 degrees/mm  
x: Time  
Scale Factor: 0.04 seconds/mm

Response Output Signal  
y: Angular Position  
Sinusoidal Output  
Frequency: 0.100 Hz  
Scale Factor: 0.6 degrees/mm  
x: Time  
Scale Factor: 0.04 seconds/mm

Command Input Signal  
y: Angular Position  
Sinusoidal Input  
Frequency: 0.100 Hz  
Scale Factor: 0.6 degrees/mm  
x: Time  
Scale Factor: 0.04 seconds/mm

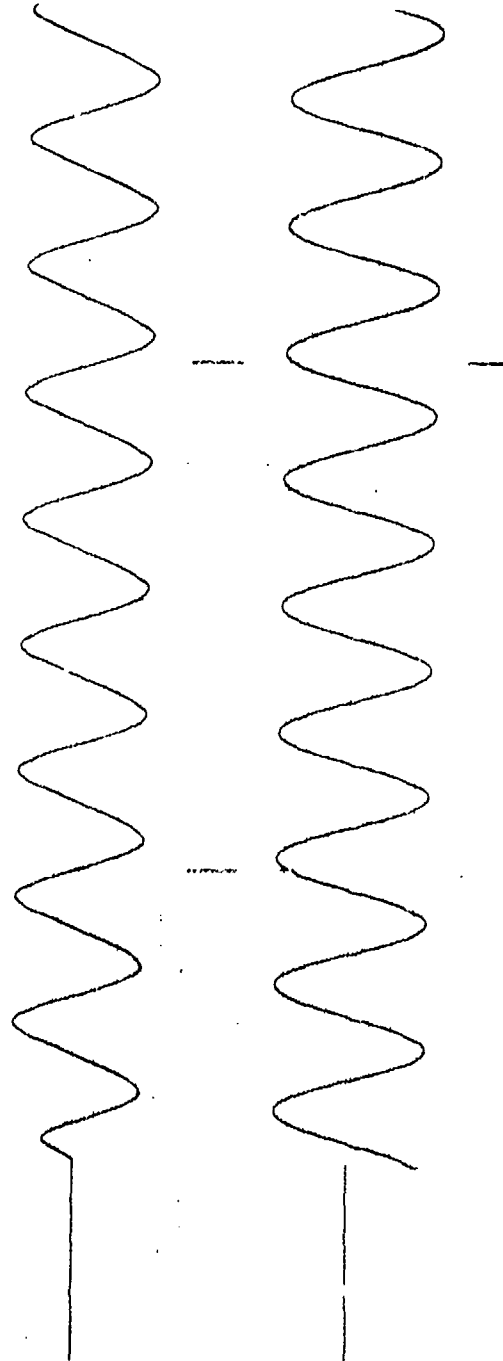

Figure 12. Recorded input/output tracings for the radially oriented axis.

These curves were obtained from analog instrumentation mounted on the rotary structure that provides constant voltage excitation and signal conditioning to potentiometer-type sensors that monitor tilt ( $\pm 30$  deg) of the fuselage base platform about its radial and tangentially oriented axes. Similarly, angular position of the main rotary structure (0-360 deg) relative to the enclosing room, can be monitored. Angular velocity ( $0 \pm 150$  deg/s) of the main rotary structure can be monitored in the control room by a meter driven by the output of a tachometer generator.

In addition to the onboard analog instrumentation, two forced-balanced inclinometer transducers are mechanically installed to monitor the angular position (pitch and roll) of the fuselage. One on the base platform section monitors the radially oriented axis. The other one on the base platform section monitors the tangentially oriented axis.

### Slip Ring Assembly

Electrical power and signals to all electrical equipment on the rotary structure are transmitted by way of brushes, housed in the center pedestal, that contact slip-rings on the main central axis of the rotary structure. Electrical signals emanating from the rotary structure, response data of subjects, and bioelectric potentials are transmitted via the slip-ring assembly to the control room. Because pitch and roll of the fuselage does not exceed  $\pm 30$  deg, flexible hardwired lines provide electrical connections between the central rotary structure and all systems on the long radial arm including the fuselage and cockpit.

The Vertifuge System has 3 sets of 30 slip rings each. The three sets are stacked one above the other and are distributed as follows:

Top stack:	Transmits inertial and physiological signals.
Middle stack:	Transmits control signals.
Bottom stack:	Transmits 115 Vac 30 A electrical power for the onboard HP-1000 digital computer, projector interface, power supplies for the two HP-1346 CRTs inside the cockpit, HP-IB Extender interface, and five onboard projectors.

### **THE PROJECTED VISUAL DISPLAYS**

Visual displays can be projected on the visual surrounds from two sets of projectors, identified as Set I and Set II in Fig. 2. Set I, referred to as the overhead projector system, is suspended from the center of the ceiling of the chamber and is fixed relative to the Earth. Earth-fixed scenes or patterns

covering 360 deg can be projected on the visual surround and can be changed from the control room by computer. Currently available are star scenes and a 360-deg aerial view of distant terrain.

Projector Set II (see Fig. 2) is affixed to the short radial arm of the Vertifuge rotary structure. This projector set is primarily useful when the Vertifuge is in the centripetal configuration (Fig. 3). Because these projectors are fixed relative to the rotary structure, external visual target scenes or patterns can be presented at various selected angular displacements relative to the subject in the cockpit. During presentation of targets by projector Set II, referred to as the onboard projectors, angular displacement of projected visual targets will be fixed relative to the subject in the cockpit, irrespective of the state of motion of the main rotary structure, when the fuselage is not pitching or rolling. During pitch or roll of the fuselage, visual targets generated by the onboard projectors will change angular position relative to the subject as the fuselage moves relative to the main rotary structure. Details of these two projector systems follow below.

### Overhead Projector System

(Projector Set I, Fig. 2). The overhead projector system is composed of 11 Mast II random access projectors mounted on a circular platform 91.44 cm in radius, suspended from the center of the ceiling in the chamber area. The projector lenses are located along the circumference of a circle 1.07 m in radius, spaced at 32.73-deg intervals so that their projections on the wall of the chamber area overlap and provide 360-deg screen projection.

The overhead projectors are controlled by an HP-1000 digital computer/controller located in the control room area via the HP-6942 Multiprogrammer Interface Unit connected to the computer by an HP-IB interface. The optical output of each projector is determined by an electromechanical shutter and a shutter control unit. The overhead projectors can be controlled in sets of three or four projectors or all simultaneously. The control functions that can be performed are:

1. Turn power to the projector(s) ON/OFF.
2. Search for any slide number from 1 through 80.
3. Advance projectors one slide forward or backward.
4. Open or close electromechanical shutters.

### Onboard Projector System

(Projector Set II, Fig. 2). The onboard projector system is composed of five Mast II random access projectors radially oriented to project against the chamber wall through an angular

aperture of  $\pm 30$  deg. This system can project targets at 0,  $\pm 30$ , and  $\pm 60$  deg angular displacements (horizontal) relative to the subject in the cockpit when the vertifuge is in centripetal configuration. The optical output of each projector is controlled by an electromechanical shutter via a shutter control unit. The onboard HP-1000 computer can control each projector to perform the following functions:

1. Turn power to projector ON/OFF.
2. Search for any slide number from 0 through 80.
3. Advance projectors one slide forward or backward.
4. Open or close electromechanical shutters.

#### **CONTROL ROOM AREA**

The control room contains instruments, patch panels, meters, recorders, displays, computer and computer interconnections, and recording equipment necessary for controlling all Dynasim systems also within the room is equipment for maintaining visual and audio communication with the subject, and for recording and storing responses of the motion system and of the subject.

#### **Control Room Layout**

A top view of the control area illustrated in Fig. 3 shows the location of:

1. Instrumentation racks 1, 2, and 3.
2. Operator's control console rack.
3. Video monitors of the chamber area and the cockpit interior.
4. Control room HP-1000 digital computer controller.
5. HP-2563A line printer.
6. HP-2397A color terminal.
7. HP-2627A color terminal.
8. HP-2622A monochrome system terminal.

**Instrumentation Racks.** Figure 13 is a photograph of the front side of the instrument racks, numbered 1 through 3 from right to left. Rack #1 houses two Bogen audio power amplifiers model CT100B, microphone input selection relay circuitry, and speaker/headset output selection relay circuitry to provide communication between the chamber area, control room, ready room, preparation room, and cockpit.

Amplifier #1, mounted on the upper section of the front panel is connected so that microphone inputs from the chamber room, ready room, preparation room, and cockpit can be selected for amplification via the input selection relays. Microphone input from the control room feeds directly into this amplifier. Low impedance output of this amplifier feeds directly to the subject's headset in the cockpit. The line output of this

amplifier can be used to power, via the output selection relays, speakers installed in the chamber room, ready room<sup>1</sup>, preparation room<sup>1</sup>, and cockpit.



**Figure 13.** *The front side of instrument racks in the control room.*

---

<sup>1</sup> Not shown in Fig. 3

Amplifier #2, mounted on the front panel under power amplifier #1, has its inputs directly connected to microphones from the chamber room, ready room, preparation room, and cockpit's microphone; the microphone from the control room is not connected to this amplifier. The line output from amplifier #2 is connected directly to the speakers in the control room and can be connected to power via the output selection relays to the speakers in the chamber room, ready room, preparation room, and subject's headset in the cockpit. The low impedance output of this amplifier is connected directly to the operator's headset.

The output selection relays circuit is used to connect the chamber room, ready room, preparation room speakers, and the cockpit's or subject's headset to either the line output of amplifier #1 or amplifier #2.

Instrumentation rack #2 houses the digital instrumentation patch panel #1, analog instrumentation patch panel #2, Datacheck model 1200B (VS) eight single-channel analog CRTs signal monitors, HP-8848A eight-channel analog instrumentation signal conditioner power supply, and HP-7558A eight-channel thermal recorder.

The digital instrumentation patch panel #1 (DIPP1), mounted in the upper section of the front panel, is used to terminate all analog to digital converter inputs from the analog to digital interface card in stalled in the control room HP-1000 computer, all digital to output converter outputs from the digital to analog interface card, as well as the digital input/outputs, relay contact outputs, digital timer input/outputs from the HP-6942 multiprogrammer interface unit.

The analog instrumentation patch panel #2 (AIPP2), mounted under DIPP1, is used to terminate the input and/or outputs of the following electrical equipment:

1. HP-8848A eight-channel signal conditioners power supply.
2. HP-7758A eight-channel thermal recorder.
3. TEAC R-80 four-channel analog tape recorder.
4. Data check 1200B(VS) eight-channels CRT analog monitors.
5. Wavetek programmable generators model 275.
6. +5 V dc power supply.
7. +15 V dc power supply.
8. -15 V dc power supply.

In addition, 40 slip rings from the pedestal of the Vertifuge terminate at this panel. These are used to send control and instrumentation signals as well as input and output

control signals from the analog electronic controllers of the pitch and roll servo position systems.

Patch panel terminations of DIP1 are made to patch panel terminations of AIPP2 to interconnect analog signals (instrumentation and/or control) to the analog-to-digital converter and from the digital-to-analog converter interfaces of the HP-1000, as well as input/output digital/discrete signals used as interrupts, and control.

Under the AIPP2, instrumentation rack #2 houses the HP-8848A, eight-channel signal conditioner amplifiers, Datacheck 1200B(VS) eight-channel CRT analog monitor Unit, and HP-7758A eight-channel thermal recorder.

Instrumentation rack #3 supports the HP-6942 Multiprogrammer Unit mounted at the upper section of the front panel, three Wavetek programmable generators model 275 mounted below the multiprogrammer unit, the TEAC R-80 four-channel analog instrumentation tape recorder, and the HP-8165A signal programmable source.

**Operator's Control Console Rack.** The operator's control console rack is a free-standing rack with a sloped front panel having the following:

1. ac/dc power control switches.
2. Cockpit heading position indicator.
3. Elapsed time meter.
4. Angular position indicator of cockpit's pitch and roll axes.
5. Armature current indicator of main drive for the rotary structure.
6. Angular velocity indicator for the main rotary structure.
7. Command control potentiometer for angular velocity of the rotary structure.
8. Command control potentiometer for the fuselage pitch and roll angular position.
9. Control stick select switch to allow subject or operator control of fuselage pitch and roll angular position.
10. Control switch to enable or disable the automatic alignment with resultant linear acceleration vector.

Figure 14 is a photograph of the front panel of the operator's control console. The electronic amplifier for the controller of the main drive motor and electronic amplifier controllers for both pitch and roll hydraulic servo position systems are mounted inside the operator's control console. Access to these controllers is available through the control

console panel and the front door of the control console. Video monitors are mounted on a shelf above the operator's control console.

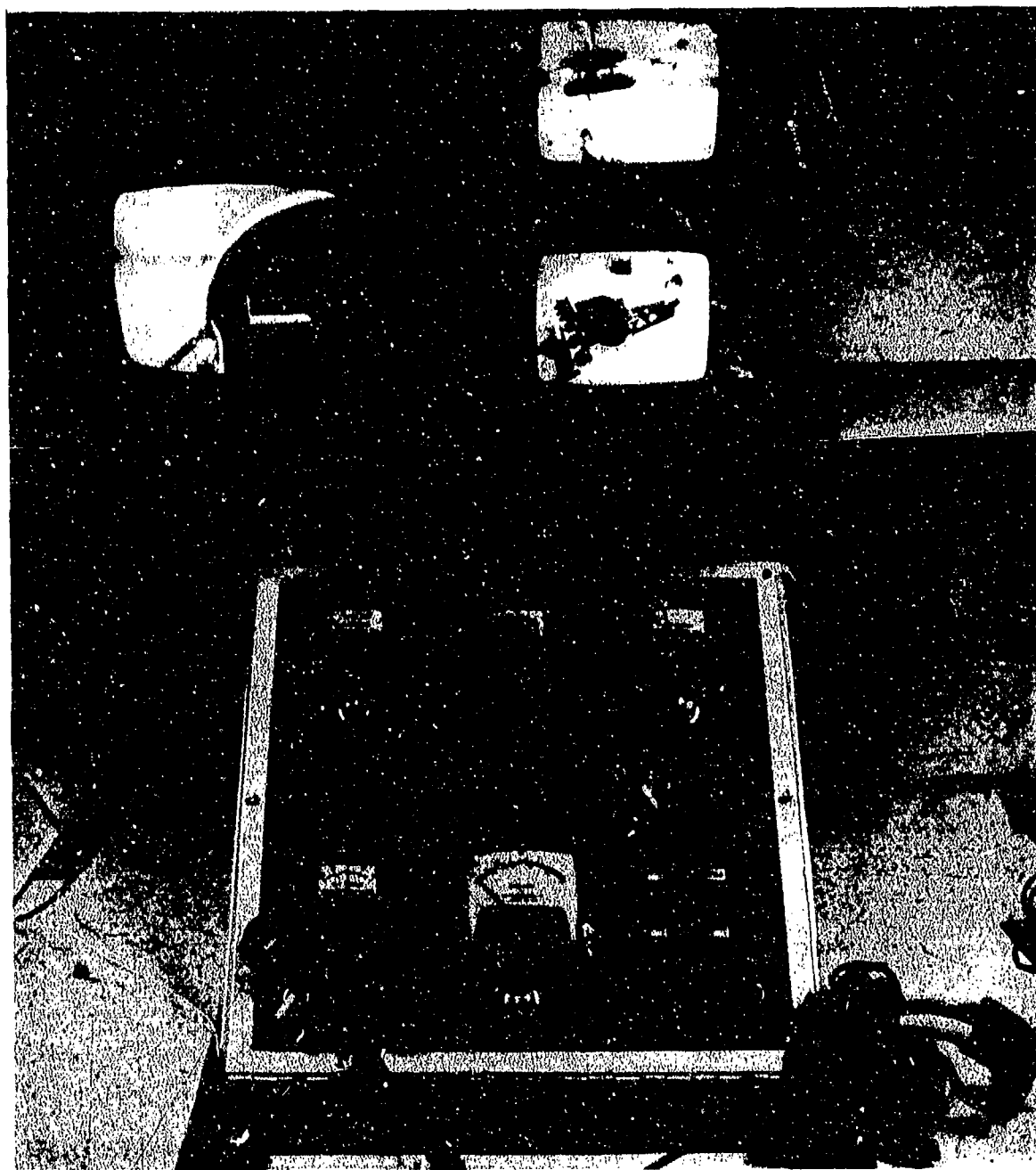

Figure 14. *Front view of the operator's control console.*

## **DIGITAL CONTROLLER SYSTEM**

Dynasim's digital controller subsystem is composed of two HP-1000 digital computer controllers, namely the onboard HP-1000 digital computer and the control room HP-1000 digital computer.

The HP-1000 controllers are linked together by the HP-12007A DS/1000-IV modem interfaces on each computer and wiring interconnection through the topstack of the slip ring assembly.

### **Onboard Computer System**

The HP-1000 digital computer controller system hardware is configured as follows:

- One HP-1000 digital computer with 1536 Kb of RAM memory.
- One HI-12022 built in 20 Mb hard disc drive.
- One HP-12005B serial interface card.
- One HP-2622A monochrome terminal.
- One HP-12060A eight-channels differential analog-to-digital converter.
- Two HP-12006B parallel input output interface.
- One HP-12007A DS/1000-IV modem link interface.
- One HP-IB extender unit to the computer's HP-IB interface.

The Onboard HP-1000 digital computer software runs under control of the Real Time Executive Software Operating System RTE-A. The operating system provides a multiuser and multitasking operating environment.

The Onboard HP-1000 digital controller runs that portion of the Dynasim's software operating system used to administer all the UTC-PAB tests, controls operation of the onboard projectors subsystem, collects subject response switch closures and two-axis joystick flight control responses, and communicates with the control room HP-1000 digital controller via the DS/1000 network system.

### **Control Room Computer**

The HP-1000 digital computer controller system hardware is configured as follows:

- One HP 1000 digital computer with 1536 Kb of RAM memory.
- One HP-12009A HP-IB interface.
- One HP-7914R 132 Mb hard disc drive.
- One HP-2563A graphics/line printer.
- One HP-2397A color terminal.
- One HP-2627A color graphics terminal.

One HP-2622A monochrome system terminal.  
Three HP-12060A eight-channel differential analog-to-digital converters.  
One HP-12062A four-channel digital-to-analog converter.  
Three HP-12006A parallel input/output interfaces.  
One HP-12040B eight-channel asynchronous interface.  
One HP-12007A DS/1000-IV modem link interface.

The HP-1000 digital computer controller subsystem software runs under control of the Real Time Executive Software Operating System RTE-A. The operating system provides a multiuser and multitasking operating environment.

The control room HP-1000 digital controller runs that portion of the Dynasim's software operating system used to control the operation of all three axes of the Vertifuge, namely angular speed of the main rotary structure about its central Earth-vertical axis and the angular position of the fuselage base platform about its radial and tangential axes. In addition, the controller is used to control the random access projectors of the overhead projector subsystem and to communicate with the onboard HP-1000 digital controller via the DS/1000 network system.

#### **SOFTWARE OPERATING SYSTEM**

The Dynasim software operating system is a set of software programs used in conjunction with the Vertifuge to produce controlled motion stimuli and to present various cognitive tasks to a subject in the cockpit. The Dynasim software system provides the user-defined motion commands (pitch, roll, and/or angular rotation or yaw) to generate the motion stimuli. It controls presentation of projector images and collects data from the subject and from the Vertifuge and other peripheral devices. It stores data in time-stamped disc files for later analysis and presentation.

All Dynasim operations are menu-controlled, with the exception of abort processing, which is either menu-selectable or run from any of the other signed-on terminals. Function keys F1 through F8, located on top of the terminal keyboard and displayed on the bottom portion of the CRT, are used to select desired functions displayed on any given screen.

The major Dynasim menu operations are the following:

(a) Stimulus Function. This function defines how the Vertifuge system is to be moved during a run. Each axis (pitch and roll position and yaw or rotation) is defined separately, but on the same time line. Allowable positioning functions are DC, sinusoidal, and ramp.

(b) Response Function. This function defines how data are to be collected from the Vertifuge: A total of 24 analog input channels of data can be collected.

(c) Storage Function. This function is used to define up to 16 different variables for storage to disc during inertial operation.

(d) Projector Function. This function defines how and when the over head and/or onboard projector systems are to be used. Projector functions may be triggered by time or by yaw-axis position.

(e) UTC-PAB Functions. This function allows the existing UTC-PAB tests to be started or triggered at user-definable times during a particular test run.

(f) Integrated Vertifuge Control Function. This function ties all above listed functions to a common time line for execution. The Dynasim software operating system runs under control of the RTE-A operating system of the HP-1000 digital computer controllers (onboard and control room). The multitasking features of the RTE-A operating system allow the scheduling of different tasks to run concurrently. Software development or upgrade is done with the HP-1000 controller in the control room.

The HP-1000 computer in the control room is the one used to bring the Dynasim software operating system on line when power is initialized. Once test programs to be used on the onboard HP-1000 computer have been developed with the HP-1000 control room computer, they are downloaded from the HP-1000 control room computer to the onboard HP-1000 via the DS/1000-IV communication network.

## OVERVIEW OF DYNASIM CAPABILITIES

### VERTIFUGE MOTION

Yaw Axis: 0-25 rpm (1.75-G centripetal acceleration maximum).  
Roll Axis: 0 to  $\pm 30$  deg from earth vertical, peak angular velocity of 8.00 deg/s<sup>2</sup>.  
Pitch Axis: 0 to  $\pm 30$  deg from earth vertical, peak angular velocity, 8.00 deg/s<sup>2</sup>.

### COCKPIT MOTION CONTROL SOURCES

Computer control from control room  
Pilot control from cockpit  
Combined control room/pilot control

### COCKPIT CANOPIES

Clear  
Translucent  
Opaque

### CHAMBER VISUAL SURROUND

White background-without pattern  
Overhead projection system-selected patterns/visual fields  
Moving Horizon: onboard projectors

### PERFORMANCE TEST BATTERY

#### Cognitive Performance Assessment Battery (UTC-PAB Test)

Matrix Rotation Test  
Two-Column Addition Test  
Continuous Recall Test  
Tapping Test  
Hidden Figure Test

#### High Face Validity Tasks

"Flying" by ADI (RMS tracking error)  
"Flying" by Malcolm Horizon (RMS tracking error)

## REFERENCES

1. Lockridge, K., *Current Issues- Flight Safety in High-Performance Aircraft*, Panel presentation at the Aerospace Medical Association Annual Meeting, Las Vegas, NV, May 1987.
2. Edgington, K. and Box, C.J., "Disorientation in Army Helicopter Operations." *Advisory Group for Aerospace Research and Development CP-287*, pp. B6-1 to B6-6, Technical Editing and Reproductions Ltd., Harford House, London, October 1980.
3. Hixson, W.C. and Spezia, E., *Major Orientation-Error Accidents in Regular Army UH-1 Aircraft during FY71: Accident Factors*, NAMRL-1219, Naval Aerospace Research Laboratory, Pensacola, FL, July 1975.
4. Tormes, F.R. and Guedry F.E., "Disorientation Phenomena in Naval Helicopter Pilots." *Aviation, Space, and Environmental Medicine*, Vol. 46, No. 4, pp. 387-393, 1975.