



**AD-A283 821**

ADST/WDL/TR--94 03017-V3.0



# Advanced Distributed Simulation Technology

System Definition Document  
Version 3.0

Loral ADST Program Office  
12151-A Research Parkway  
Orlando, FL 32826

March 10, 1994

Contract N61339-91-D-0001

Prepared for:

U.S. Army Simulation, Training and Instrumentation Command  
12350 Research Parkway  
Orlando, FL. 32826-3275

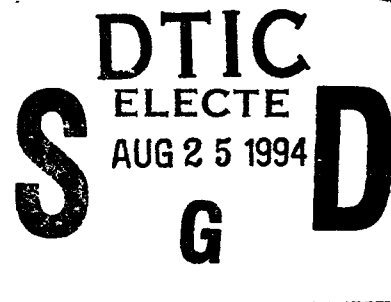

**LOREAL**

DTIC QUALITY INSPECTED 8

94-27167



122P

94 8 24 1 90

**Best  
Available  
Copy**

# REPORT DOCUMENTATION PAGE

Form approved  
OMB No. 0704-0188

Public reporting burden for this collection of information is estimated to average 1 hour per response, including the time for reviewing instructions, searching existing data sources, gathering and maintaining the data needed, and completing and reviewing the collection of information. Send comments regarding this burden estimate or any other aspect of this collection of information, including suggestions for reducing this burden, to Washington Headquarters Services, Directorate for Information Operations and Reports, 1215 Jefferson Davis Highway, Suite 1204, Arlington, VA 22202-4302, and to the Office of Management and Budget Project (0704-0188), Washington, DC 20503.

1. AGENCY USE ONLY (Leave blank)		2. REPORT DATE 3/10/94	3. REPORT TYPE AND DATES COVERED Version 3.0, 3/91 - 3/94	
4. TITLE AND SUBTITLE Advanced Distributed Simulation Technology System Definition Document			5. FUNDING NUMBERS Contract No. N61339-91-D-0001	
6. AUTHOR(S)  Compiled by: Jerry Novak, ed.				
7. PERFORMING ORGANIZATION NAME(S) AND ADDRESS(ES) Loral Systems Company ADST Program Office 12151-A Research Parkway Orlando, FL 32826-3283			8. PERFORMING ORGANIZATION REPORT NUMBER ADST/WDL/TR--94-03017-V3.0	
9. SPONSORING/MONITORING AGENCY NAME(S) AND ADDRESS(ES) U.S. Army Simulation, Training and Instrumentation Command (STRICOM) Naval Training Systems Center 12350 Research Parkway Orlando, FL 32826-3275			10. SPONSORING ORGANIZATION REPORT	
11. SUPPLEMENTARY NOTES				
12a. DISTRIBUTION/AVAILABILITY STATEMENT  Approved for public release; distribution is unlimited.			12b. DISTRIBUTION CODE  	
13. ABSTRACT (Maximum 200 words)  This document contains a concise description of the system under the cognizance of the Advanced Distributed Simulation Technology (ADST) contract. Included are descriptions of the current hardware and software configurations, as well as information on system configuration management, systems engineering, networked simulation standards, terrain and sensor databases, simulation validation, the ADST Technical Library, and other ADST information distribution services.				
14. SUBJECT TERMS  ADST, BDS-D, Configuration Management, Networking, Simulation, STRICOM, Systems Engineering			15. NUMBER OF PAGES	
			16. PRICE CODE	
17. SECURITY CLASSIFICATION OF REPORT UNCLASSIFIED	18. SECURITY CLASSIFICATION OF THIS PAGE UNCLASSIFIED	19. SECURITY CLASSIFICATION OF ABSTRACT UNCLASSIFIED	20. LIMITATION OF ABSTRACT UL	

NSN 7540-01-280-5500

Standard Form 298 (Rev. 2-89)  
Prescribed by ANSI Std Z39-18  
298-102



# Advanced Distributed Simulation Technology



ADST/WDL/TR--94-03017-V3.0

## System Definition Document

Version 3.0 Draft

March 10, 1994

Contract N61339-91-D-0001

Prepared by:

Loral ADST Program Office  
12151-A Research Parkway  
Orlando, FL 32826

Prepared for:

U.S. Army Simulation, Training and Instrumentation Command  
12350 Research Parkway  
Orlando, FL 32826-3275

Accession For	
NTIS CRA&I	<input checked="" type="checkbox"/>
DTIC TAB	<input checked="" type="checkbox"/>
Unannounced	<input type="checkbox"/>
Justification	.....
By .....	
Distribution/ .....	
Availability Codes	
Dist	Avail and/or Special
A-1	

1994

---

**TABLE OF CONTENTS**

1	Introduction.....	1
2	Physical Configuration .....	2
2.1	Simulators and Simulation Support Assets.....	2
2.1.1	Combat Vehicle Command and Control (CVCC) Simulator .....	3
2.1.1.1	CVCC Tank Description.....	3
2.1.1.2	CVCC Tank Operations .....	4
2.1.2	Data Logger .....	4
2.1.2.1	Data Logger Description.....	4
2.1.2.2	Data Logger Operation.....	4
2.1.3	Fixed Wing Aircraft (FWA).....	5
2.1.4	Generic Air Defense Devices (GADDS) .....	5
2.1.5	Line-of-Sight Anti-Tank (LOSAT) .....	5
2.1.6	Management Command and Control .....	5
2.1.6.1	MCC Workstation Operations .....	6
2.1.6.2	Engineer Workstation Operations .....	6
2.1.7	M1 Tank .....	7
2.1.7.1	M1 Description .....	7
2.1.7.2	M1 Operations .....	7
2.1.8	M1A2 Tank.....	7
2.1.8.1	M1A2 Description.....	7
2.1.8.2	M1A2 Operations.....	8
2.1.9	M2/M3 .....	8
2.1.9.1	M2/M3 Description.....	8
2.1.9.2	M2/M3 Operations .....	8
2.1.10	Non-Line-of-Sight (NLOS) System.....	8
2.1.11	Plan View Display.....	9
2.1.11.1	Plan View Display Description .....	9
2.1.11.2	Plan View Display Operations .....	9
2.1.12	Rotary Wing Aircraft (RWA) .....	9
2.1.13	Semi-Automated Forces (SAFOR) .....	10
2.1.13.1	SAFOR Description.....	10
2.1.13.2	SAFOR Operations.....	10
2.1.14	Shadow Box .....	11
2.1.15	Stealth.....	11

1994

**TABLE OF CONTENTS (continued)**

2.2	ADST Sites .....	11
2.2.1	Fort Knox Mounted Warfare Test Bed (MWTB).....	12
2.2.2	Fort Rucker Aviation Test Bed (AVTB) .....	18
2.2.3	ADST Operations, Orlando.....	26
2.2.3.1	SDF Functional Description.....	29
2.2.4	Institute for Defense Analysis (IDA) .....	31
2.2.5	Interfacing Sites.....	33
2.2.5.1	MULTIRAD (Williams AFB).....	33
2.2.5.1.1	Network Interface Unit (NIU) Enhancements.....	34
2.2.5.1.2	Network Communication Protocol.....	34
2.2.5.1.3	Long Haul Network (LHN). .....	35
2.2.5.4	Close Air Support.....	35
2.2.5.2	CSRDF (NASA-Ames).....	35
2.3	Site Interconnectivity .....	37
2.3.1	ADST Orlando Operations Connectivity.....	38
2.3.2	San Jose Connectivity.....	39
2.3.3	IST Connectivity.....	39
2.3.4	Fort Rucker, Fort Knox Connectivity.....	40
3	Software.....	41
3.1	Data Logger.....	47
3.1.1	Description .....	47
3.1.2	Documentation .....	47
3.1.3	Software .....	48
3.1.4	Computer Software Configuration Item (CSCI) Breakdown .....	48
3.2	Digital Message Communications Console (DMCC).....	48
3.2.1	Description .....	48
3.2.2	Documentation .....	49
3.2.3	Software .....	49
3.2.4	Computer Software Configuration Item (CSCI) Breakdown .....	49
3.3	M1/M2/Stealth Simulators .....	50
3.3.1	Description .....	50
3.3.2	Documentation .....	51
3.3.3	Software .....	52
3.3.4	Computer Software Configuration Item (CSCI) Breakdown .....	53

1994

**TABLE OF CONTENTS (continued)**

3.4	Combat Vehicle Command and Control (CVCC).....	52
3.4.1	Description .....	52
3.4.2	Documentation .....	53
3.4.3	Software .....	53
3.5	Protocol Translator (PT).....	54
3.5.1	Description .....	54
3.5.2	Documentation .....	54
3.5.3	Software .....	55
3.5.4	Computer Software Configuration Item (CSCI) Breakdown .....	55
3.6	Plan View Display (PVD).....	55
3.6.1	Description .....	55
3.6.2	Documentation .....	56
3.6.3	Software .....	56
3.6.4	Computer Software Configuration Item (CSCI) Breakdown .....	56
3.7	Semi-Automated Forces (SAF) .....	56
3.7.1	Description .....	56
3.7.2	Documentation .....	57
3.7.2.1	SIMNET SAF .....	57
3.7.2.2	OBG/SAF .....	57
3.7.2.3	ModSAF.....	57
3.7.3	Software .....	57
3.7.3.1	SIMNET SAF .....	57
3.7.3.2	OBG/SAF .....	58
3.7.3.3	ModSAF.....	58
3.7.4	Computer Software Configuration Item (CSCI) Breakdown .....	58
3.7.2.1	Graphical User Interface (GUI) .....	58
3.7.2.2	Parameter Editor.....	58
3.7.2.3	SAF Simulation.....	58
3.8	Rotary Wing Aircraft (RWA) Simulator .....	59
3.8.1	Description .....	59
3.8.2	Documentation .....	60
3.8.3	Software .....	60
3.9	Computer Image Generator (CIG).....	60
3.9.1	Description .....	60

1994

---

**TABLE OF CONTENTS (continued)**

---

4.2.1	System Architecture Definition .....	81
4.2.2	The Synthetic Environment and the Common Database .....	83
4.2.3	Simulation Verification, Validation, and Accreditation (VV&A) .....	84
4.2.4	Networked Simulation Standards .....	84
4.2.4.1	Modular Simulator Standards .....	85
4.2.4.2	Network Protocol Standards .....	85
4.2.5	Terrain and Sensor Databases .....	86
4.2.6	Tape Backup Library .....	88
4.2.7	Technical Reference and Training Library .....	88
4.2.8	Software Reuse .....	88
4.2.9	Software Support .....	88
4.3	Information Services .....	88
4.3.1	ADST Technical Library .....	89
4.3.2	ADST Bulletin Board System (BBS) .....	91
4.3.2.1	Bulletin Board Configuration .....	91
4.3.2.1.1	ADST BBS Components .....	93
4.3.3	Defense Technical Information Center (DTIC) .....	96
5	References .....	97
	Appendix A: Research Areas .....	A - 1
	Appendix B: ADST Points of Contact .....	B - 1
	Appendix C: Deliverables and Products by Delivery Order .....	C - 1
	Appendix D: Acronyms .....	D - 1

1994

---

**LIST OF FIGURES**

---

Figure 2.2.1-1	Mounted Warfare Test Bed Facility Layout .....	13
Figure 2.2.1-2	Mounted Warfare Test Bed Functional Diagram (1 of 2).....	14
Figure 2.2.1-2	Mounted Warfare Test Bed Functional Diagram (2 of 2).....	15
Figure 2.2.2-1	Fort Rucker Aviation Test Bed Facility Layout.....	21
Figure 2.2.2-2	Aviation Test Bed Functional Diagram (1 of 2).....	22
Figure 2.2.2-2	Aviation Test Bed Functional Diagram (2 of 2).....	23
Figure 2.2.2-3	AVTB Standard Communications Profile .....	25
Figure 2.2.3-1	ADST Program Office and Engineering Work Area .....	26
Figure 2.2.3-2	ADST/BDS-D Software Development Facility .....	27
Figure 2.2.3.1-1	SDF Network Diagram-Level 1 .....	29
Figure 2.2.3.1-2	SDF Network Diagram-Level 2 .....	30
Figure 2.2.3.1-3	SDF Fiber Optic Network Distribution .....	31
Figure 2.2.4-1	IDA Functional Diagram.....	32
Figure 2.2.5.1-1	MULTIRAD Network Diagram .....	34
Figure 2.2.5.2-1	CSRDF/AVTB Connectivity Diagram .....	37
Figure 2.3-1	Network Interconnectivity.....	38
Figure 2.3.1-1	Orlando ADST PMO EIEN Connectivity.....	39
Figure 2.3.4-1	Fort Knox MWTB, EIEN Connectivity.....	40
Figure 2.3.4-2	Fort Rucker AVTB, EIEN Connectivity.....	41
Figure 3.1.1-1	Data Logger Diagram .....	47
Figure 3.2.1-1	Digital Message Communication Console (DMCC) Diagram.....	49
Figure 3.3.1-1	M1/M2/Stealth Simulator Diagram .....	51
Figure 3.4.1-1	Combat Vehicle Command and Control (CVCC) Diagram.....	53
Figure 3.5.1-1	Protocol Translator (PT) Diagram.....	54
Figure 3.6.1-1	Plan View Display (PVD) Diagram .....	55
Figure 3.7.1-1	Semi-Automated Forces (SAF) Diagram .....	57
Figure 3.8.1-1	Rotary Wing Aircraft (RWA) Diagram .....	60
Figure 3.9.1-1	Computer Image Generator (CIG) Diagram.....	61
Figure 3.10.1-1	Vehicle Integrated Defense System (VIDS) Diagram .....	63
Figure 3.11.1-1	Masscomp Hosted Management Command and Control (MCC) Diagram.....	64
Figure 3.12.1-1	MIPS Hosted Management Command and Control (MCC) Diagram..	66

1994

---

**LIST OF FIGURES (continued)**

---

Figure 4-1	System Engineering Diagram .....	70
Figure 4.1.3.2-1	Software Support Library Structure.....	75
Figure 4.1.3.2-2	CM SSL Baseline Hierarchy.....	77
Figure 4.3.1-1	Technical Library Maintenance and Information Distribution.....	90
Figure 4.3.2.1.1-1	ADST BBS Block Diagram .....	94

1994

---

**LIST OF TABLES**

---

Table 1-1	ADST Delivery Orders.....	2
Table 2.1-1	Simulator Characteristics .....	3
Table 2.2.1-1	Major Equipment at the MWTB .....	17
Table 2.2.2-1	Major Equipment at the AVTB.....	20
Table 3-1	SIMNET 6.6.0 Software Design Documents.....	43
Table 3-2	CSCI Versions for SIMNET Version 6.6.1 .....	44
Table 3-3	Current Versions of Other CSCIs .....	44
Table 3-4	Initial Source Code Delivery .....	46
Table 4.1.3.1-1	SWCCP Current Status.....	73
Table 4.2.1-1	BDS-D Architectural Components .....	82
Table 4.2.2-1	Currently Modeled Weapon Systems .....	83
Table 4.2.4-1	Networked Simulation Standards Activities.....	85
Table 4.2.5-1	SIMNET Terrain Databases.....	87
Table 4.3.2.1-1	ADST BBS Configuration .....	92
Table 4.3.2.1.1-1	BBS Equipment .....	94
Table 4.3.2.1.1-2	TEAMate Features.....	96
Table A-1	ADST Research Areas .....	A - 1

## 1 INTRODUCTION.

This document contains a concise description of the system under the cognizance of the Advanced Distributed Simulation Technology (ADST) contract at the end of the twelfth quarter (March 10, 1991 through March 10, 1994). This system includes elements of the Battlefield Distributed Simulation - Development (BDS-D) Program, such as the two BDS-D Test Bed sites at Fort Knox and Fort Rucker. The BDS-D system is, in large part, driven by BDS-D Program exit criteria<sup>1</sup>. The first major steps toward satisfying these exit criteria were taken in the BDS-D Architecture Delivery Orders (D.O.s) which have resulted in the Architecture Documents<sup>2</sup>.

This document is also complementary to the BDS-D Guidebook<sup>3</sup>. The BDS-D Guidebook is designed to acquaint the customer with the Battlefield Distributed Simulation - Developmental (BDS-D) Program, the ADST Program, and the purposes and relationships of each of these programs. The guidebook answers some of the more frequently asked questions concerning the program and the benefits and opportunities it can provide. This document provides the most current description of the components that make up the BDS-D system.

This description includes references to other documents which have been identified as comprising the most complete description of the current system with coverage of all system aspects and minimum redundancy. Where no such existing document is available (for example, for a program in progress which has not yet resulted in deliverable documentation), the System Definition Document will provide this information where appropriate.

This document is divided into sections discussing the system's physical and operational configuration and its software configuration. Additional information is provided on key systems engineering activities, such as configuration management, standards, databases, and information services.

A short discussion is attached in Appendix A on the research areas given in the ADST Statement of Work (SOW). This discussion describes the ways in which various efforts, mostly through D.O.s, have contributed to these areas. Appendix B provides a list of ADST Points of Contact.

This document addresses the configuration of the core system, as well as changes made through D.O.s and Engineering Change Orders (ECOs) during the year. The current status of

ADST Delivery Orders<sup>4</sup> is provided in Table 1-1. Appendix C provides a list of deliverables and products by delivery order. Finally, a glossary of terms and list of references is provided in Appendix D.

Table 1-1. ADST Delivery Orders

ACTIVE DELIVERY ORDERS	POTENTIAL DELIVERY ORDERS	COMPLETED DELIVERY ORDERS
BDS-D Architecture Definition & DIS Standards Development	XMDEWS	Hollis Experiment
Horizontal Integration	ARWA Phase II	Land Systems Future Battlefield
MDT2	AUSA May Demonstration 1994	Leavenworth Node
DOS Training Delivery Order	05/06 TOC	Seamless Simulation Experiment
Jayhawk Thunder	FARV	Smart Minefield Simulator
BDS-D System Definition Support	Fox NBCRS	CVCC Battalion Formative Evaluation
ModSAF	DISCSS	Battlefield Synchronization Demonstration
MULTIRAD	Anti-Armor ATD	X-Rod (Experimental AT Missile)
A <sup>2</sup> ATD Phase II		CVCC 93 Tests
Non-Line-of-Sight		CSRDF - BDS-D Interface
Advanced Rotary Wing Aircraft Phase I		AirNet AeroModel and Weapons Model Conversion
Vehicle Integrated Defense Systems (VIDS) Phase III		Rotary Wing Aircraft
Infoscope		MULTIRAD/Warbreaker
National Guard		VIDS Phases I and II
Stingray		Jayhawk Thunder Phase I
Dynamic Terrain		SASC Demonstration
GuardFIST		M1A2 Superthreats
		Testbed Expansion
		Skalnotty
		AUSA February Demonstration 1993
		DOTD

## 2 PHYSICAL CONFIGURATION.

The physical configuration of the system includes the computers, networking, and other equipment and subsystems required to conduct a distributed interactive simulation session. The primary emphasis of the experiments and exercises conducted on this system is on soldier-in-the-loop simulation. Additionally, information about the geographical sites which house the equipment is provided.

## **2.1 Simulators and Simulation Support Assets.**

Table 2.1-1 lists the various simulators and some of their capabilities.

Table 2.1-1. Simulator Characteristics

TYPE	CREW	OTW CIG	CHAN- NELS	RANGE (km)	SENSORS	RANGE (km)	ARMA- MENT	OTHER
CVCC	3	GT-111		3.5	CITV	3.5	105 mm Cannon	IVIS
			1	7				SINCGARS
								POSNAV
FWA	1	GT-111	8	3.5	RADAR	7	Maverick	
			1	7	RADAR Warning	7	Sidewinder	
					Laser Range Finder	7	GAU-8 (30mm)	
GADDS	3	GT-111			FLIR,	7	8 Air Defense Missiles	
					Day TV	7		
					Laser Range Finder	10		
					Radar	15/25		
LOSAT	3	GT-111	7	3.5	FLIR	7	Kinetic Energy Missiles	
			2	7	DAY TV	7		
M1	4	GT-101	8	3.5			105 mm	
M1A2	4	GT-111	8	3.5	CITV	7	120 mm Cannon	POSNAV
			1	7				IVIS
M2/3	3	GT-101	8	3.5			25 mm	
		or 120T / Butterfly					TOW Missiles	
NLOS	2	ESIG 2000	4	3.5	Missile	7	NLOS-TV	EPLRS
		or					NLOS-IIR	SINCGARS
		GT-111					FOG-M	
RWA	2	GT-111	8	3.5	Day TV	7	30 mm	
			1		FLIR	7	Hellfire	
					RADAR Warning	7	ATAS	
							Hydra 70 (3 Types)	
							12.7 mm	
							57 mm rockets	
							TOW Missile	
							50 cal	
							250 lb bomb	
							500 lb bomb	

### 2.1.1 Combat Vehicle Command and Control (CVCC) Simulator.

#### 2.1.1.1 CVCC Tank Description.

The CVCC simulator is a hybrid M1 tank simulator with several future tank design features. This simulator incorporates a position navigation system, a commander's independent thermal

viewer , and a modified, more complex version of the inter-vehicular information system. In addition, it has a thermal channel for the gunner.

#### **2.1.1.2 CVCC Tank Operations.**

The user manual for the tank utilized for the CVCC test is titled SIMNET Combat Vehicle Command and Control (CVC2) System (BBN, December 1990<sup>5</sup>). The Inter-Vehicular Information System (IVIS) has its own user manual, SIMNET CVCC IVIS Utilities User Manual (BBN Report No. 7631, July 1991<sup>6</sup>).

#### **2.1.2 Data Logger.**

##### **2.1.2.1 Data Logger Description.**

The data logger is an MC5600 MASSCOMP computer with a high-performance Ethernet interface to the simulation networking (SIMNET) network. The data logger can capture the network traffic and place the data packets in a disk or tape file. Given the two data logging mediums of disk and tape, logging a disk file is performed by specifying a medium of disk; and logging onto magnetic tape is performed by specifying a medium of tape. The data logger performs the following functions:

- a. Packet Recording: Receives packets from the SIMNET network, time-stamps them, and writes them to a disk or tape.
- b. Packet Playback: Packets from a recorded exercise can be transmitted in real time or faster than real time. The data logger can also suspend play back (freeze time) and skip backward or forward to a designated point in time. The logger can be controlled directly from the keyboard or remotely from the PVD. Playback is visible to any device on the network (PVD, stealth vehicle, vehicle simulator, etc.).
- c. Copying or Converting: Files are copied to another file, which can be on the same or a different medium; and files from the older version of the data logger can be converted to a format compatible with the current version of the data logger.

##### **2.1.2.2 Data Logger Operations.**

The current user manual for the data logger is SIMNET Data Logger (BBN Report No. 7617, June 1991<sup>7</sup>).

### **2.1.3 Fixed Wing Aircraft (FWA).**

The FWA is configured as a single pilot device and replicates the flight dynamics and munitions of a USAF A-10 Wart Hog aircraft. It is armed with the Maverick missile, Sidewinder missile, and the 30mm GAU-8 gun. The FWA also requires a dedicated GT-111 Computer Image Generator (CIG), but its visual effects are slightly different than those described for the RWA. Like the RWA, the FWA uses two rows of TV monitors, three monitors on the top row and five monitors on the bottom row, for OTW views. Unlike the RWA, the FWA does not have FLIR or day TV capability, but uses the CIG's high resolution channel to provide a heads-up display (HUD) and a 7 kilometer OTW view on the bottom row's center monitor. In the OPFOR mode, the FWA replicates the characteristics of a Soviet Su-25 Frogfoot aircraft armed with appropriate munitions.

### **2.1.4 Generic Air Defense Devices (GADDs).**

The generic air defense device is configured for a crew of three (driver, gunner/electro-optical operator, and squad leader/radar operator). The device requires a dedicated GT-111 CIG, which emulates most behaviors of an air defense system. The CIG also provides a 3500 meter OTW view via four vision blocks for the driver, a FLIR and day TV threat detection range of 7 km, and a laser range of 10 km. Additionally, the device features radar, with a selectable range of either 15 km or 25 km, which is driven by a Concurrent 6600 computer connected to a CIG and the network. The device is armed with eight air defense missiles which can only be launched while the vehicle is stationary.

The generic air defense devices are the ADATS or FAADS vehicles. The actual replication of these devices was for the Forward Heavy Line of Site Heavy Air Defense Systems.

### **2.1.5 Line-of-Sight Anti-Tank (LOSAT).**

The LOSAT is an experimental anti-tank system based on a Bradley IFV chassis with a hyper-velocity anti-tank missile system. This simulator was built on site with on-hand simulator components. The LOSAT unique software was installed to replicate system functionality.

### **2.1.6 Management Command and Control (MCC).**

The MCC system is responsible for simulating a variety of combat and combat service support functions. These include ammunition trucks, maintenance vehicles, fuel trucks, artillery

pieces, mortars, command posts, ground mine emplacements devices, and bombs. The host for the MCC is an MC5600 MASSCOMP computer, which incorporates a 68020 microprocessor, two megabytes of memory, a 142-megabyte hard disk, a floppy disk drive, a cartridge tape drive, an Ethernet interface, and an eight-channel RS-232 interface. Users communicate to the MCC through six Apple® Macintosh computers via an AppleTalk network and an RS-232 line. The AppleTalk network features an intermediary Macintosh called the bridge, which translates between the AppleTalk protocols understood by the Macintosh consoles and the RS-232 signals supported by the MCC host. Brief descriptions of the six Macintosh computer functions follow:

- a. Simulation Control Console. The SCC are used to start an operation, establish the scenario within which the operation takes place, initially place select vehicles on the terrain, and carry out functions (such replacing destroyed vehicles) normally performed by echelons above the particular battalion to which the user is assigned.
- b. Close Air Support. The CAS console directs aircraft, armed with 500 pound dumb bombs, against battlefield targets in either a preplanned or on-call modality.
- c. Fire support. The fire support console issues orders to one of three 155 howitzer batteries and to a mortar platoon in either a preplanned or an immediate call-for-fire modality.
- d. Combat Engineer. The combat engineer console allows the user to emplace, breach, or move minefields on the terrain.
- e. Admin/logistics. The administration and logistics console moves trucks carrying ammunition and fuel.
- f. Maintenance. The maintenance console dispatches maintenance vehicles and recovery teams.

#### **2.1.6.1 MCC Workstations Operations.**

The user manual for the Combat Service Support, Fire Support, Close Air Support, Admin/Log, Maintenance and Exercise Initiation workstations is SIMNET Master Documentation (Perceptronics, 15 September 1986<sup>8</sup>).

#### **2.1.6.2 Engineer Workstation Operations.**

The operations documentation for the Combat Engineer MCC console is Technical Report No. PTR-4070-11-8200-91/2<sup>9</sup>.

## **2.1.7 M1 Tank.**

### **2.1.7.1 M1 Description.**

The M1 tank device is a real-time simulation of the M1 Abrams main battle tank configured for a crew of four (driver, commander, gunner, and loader). The device is clocked in real-time at 15 Hz in lockstep synchronization with a dedicated GT-101 CIG. The GT-101 CIG generates eight low resolution channels (seven are for vision blocks and one is for the gunner's primary sight (GPS)) and emulates most behaviors of a real-world M1. The crew operates in a buttoned-up/closed hatch mode and views the virtual world through 1 power vision block which provides vision out to 3500 meters. The simulator's visual system permits the crew to search for and track targets and terrain features, and to maintain tactical formation while moving. The GPS is shared by the commander and features selectable 3x and 10x magnification. The device is armed with the 105mm main gun only and is capable of firing high explosive antitank (HEAT) and sabot munitions.

### **2.1.7.2 M1 Operations.**

The current M1 operations manual is SIMNET Manual No. PTUM 001-1250-89-10 (Rev. 2)<sup>10</sup>.

## **2.1.8 M1A2 Tank.**

### **2.1.8.1 M1A2 Description.**

The M1A2 incorporates a Position Navigation (POSNAV) system, a Commander's Independent Thermal Viewer (CITV), and an Inter-Vehicular Information System (IVIS). The M1A2 is unique in that the simulation by General Dynamics Land Systems (GDLS) is created on the VME chassis and interfaces with the GT-111 CIG with a modified set of interface cards. The CIG creates the graphics and interfaces with the VME chassis through the Ethernet creating the simulation.

Fort Knox has made extensive use of the M1A2 simulators for training, doctrine, and combat development activities.

### **2.1.8.2 M1A2 Operations.**

The current operators manual was produced by GDLS under contract DAAE07-91-R001, Individual - Conduct of Fire Trainer (I-COFT).<sup>11</sup>

### **2.1.9 M2/M3.**

#### **2.1.9.1 M2/M3 Description.**

The M2/M3 device replicates the shooting, moving, and communicating modes of the M2/M3 BFV and is configured for a crew of three (driver, commander, and gunner). Like the M1 above, the BFV requires a dedicated GT-101 CIG. As with the M1, the CIG generates eight low resolution channels (seven are for vision blocks and one is for the gunner's integrated sight unit (ISU)). The crew operates in a closed hatch mode and views the virtual world through 1 power vision block which provides vision out to 3500 meters. The ISU is shared by the commander and features selectable 4x and 12x magnification. The device is armed with a 25mm chain gun capable of firing high explosive and armor piercing ammunition and the Tube-launched, Optically Wire-guided (TOW) missile.

#### **2.1.9.2 M2/M3 Operations.**

The current operations manual covering the M2/M3 is SIMNET Manual No. PTUM 002-1250-89-10 (Rev.1)<sup>12</sup>.

### **2.1.10 Non-Line-of-Sight (NLOS) System.**

The NLOS system is a fiber-optic guided forward area air defense and anti-armor missile system which uses both TV and imaging infrared (IIR) missiles. The NLOS simulated at the AVTB is the light version which is mounted on the high mobility multipurpose wheeled vehicle (HMMWV), carries six missiles, and is operated by a two-member crew (driver and gunner). The system also simulates a single channel ground and airborne radio system (SINCGARS) and an enhanced position location and reporting system (EPLRS). It requires a dedicated ESIG 2000 or GT-111 CIG, which emulates behaviors of a HMMWV and a FOG-M plus provides four channels of low resolution OTW video with a field of view of approximately 160 degrees horizontal by 30 degrees vertical. Maximum visual range is 3500 meters. A higher resolution video channel serves the gunner's sensor.

## **2.1.11 Plan View Display.**

### **2.1.11.1 Plan View Display Description.**

The PVD is powered by an MC5600 MASSCOMP computer and provides high resolution and near real-time displays of data packets received from all vehicles on the network. The PVD allows the user to view the entire database or zoom in to a defined location and view a single vehicle. The PVD also provides the user with numerous map tools, terrain definition options, intervisibility checks, and overlay functions. It also connects to the data logger for remote control of exercise playback.

### **2.1.11.2 Plan View Display Operations.**

The current user manual for the PVD is SIMNET Plan View Display (BBN Report No. 7618, June 1991<sup>13</sup>).

## **2.1.12 Rotary Wing Aircraft (RWA).**

The RWA simulator is reconfigurable as either a scout or an attack aircraft. It is configured with three seats, two of which are manned at any given time, by the pilot and either the copilot/observer (CPO) or the copilot/gunner (CPG). The simulator provides auditory, tactile, and visual stimuli to replicate the effects of shooting, flying, and communicating. Visual effects are generated through eight TV monitors by a dedicated GT-111 CIG. The CIG outputs eight, low resolution channels, each channel providing a 25 x 15.6 degree view of the virtual world out to 3.5 kilometers; and one high resolution channel for the sensor system with a visual range of 7 kilometers. The total field of view available is 125 degrees horizontal and 30.2 degrees vertical. The out-the-window (OTW) views are vertically slewable and update in real time (at a 15 Hz frame rate) as the aircraft flies. The device OTW is vertically slewable in that the view plane can be moved vertically + or - 35°. Consequently, the actual vertical field of view available is 100.2 degrees. The sensor views replicate day TV and forward looking infrared (FLIR) and have various fields of view that are selectable by the CPO or CPG. These devices can replicate either U.S. or Soviet RWA. Each RWA is fully instrumented for data collection with an installed TV camera mounted inside the device, and a gun camera replication tied to the sensor system. Data collection is effected by two time-stamped synchronized video/audio recording devices; one for the sensors and one for the cockpit. The simulator can be armed with 30mm cannon, Hellfire missiles, Air to Air Stinger (ATAS), TOW, 50 caliber gun, and Hydra 70 rockets. In the opposing forces (OPFOR) mode, it is armed with Soviet counterpart munitions.

## **2.1.13 Semi-Automated Forces (SAFOR).**

### **2.1.13.1 SAFOR Description.**

SAFOR is a system of workstation-controlled computer generated forces that interact with manned simulators on the battlefield. SAFOR units are commanded by the workstation operator, who can execute pre-planned scenarios or create responses to the situation as it happens. Each workstation is capable of creating up to a battalion size force.

SAFOR is a computer representation of physical performance capabilities of a system plus the human behavior representation. SAFOR provides doctrine and tactics for the force being represented. The man-in-the-loop is there to correct or modify the behavior as required. The purpose of SAFOR is to provide a richer battlefield environment without being manpower-intensive.

The SAFOR workstation allows users to interact with the semi-automatic forces system and allows for man-in-the-loop supervisory control of air and ground SAFOR. Two configurations of SAFOR are currently used within BDS-D. The original is built around Symbolics hardware, which operates in a Genera software environment and consists of a black-and-white (B&W) monitor, a color monitor, a keyboard, and a mouse. To generate requisite simulation and interface with the local simulation network, it is connected to a MIPS 2000 simulation computer. The latest version has rehosted and enhanced the Symbolics front-end onto a MIPS 3000. The user can effect such functions as unit creation, menu-style input, message display, and execution of system functions on the B&W monitor. The color monitor is used to display terrain, effects, and units. It provides mouse-sensitive graphics facilities to adjust map scale and resolution, to issue orders to units (including combat instruction sets, boundaries, objectives, and routes), and to establish additional control measures (such as phase lines, firing positions, etc.).

### **2.1.13.2 SAFOR Operations.**

The semi-automated forces are operated from the Symbolics workstation, which consists of a keyboard, monitor, and a plan view display. The current manual on how to operate SAFOR is Semi-Automated Forces (SAF) Commander Training, SIMNET (Perceptronics, 11 March 1991<sup>14</sup>). SAFOR Version 3.10.6, released on 15 July 1991 by BBN, is the SAF used at the MWTB.

### **2.1.14 Shadow Box.**

Another viewing platform, the Shadow Box, provides the test officer with the capability to view exactly what the crew members see. The Shadow Box consists of four video monitors slaved to selected video channels in an individual simulator. Since the signal slaved to the Shadow Box is the exact signal sent to one of the nine views in the simulator, what is seen at the Shadow Box is the exact view seen from the view port from which it has been slaved. This gives the test officer the capability to see, first hand, what the crew members see.

### **2.1.15 Stealth.**

The stealth device is a simulated observation vehicle unrelated to any real-world vehicle. It acts like an invisible eye on the virtual world. The Stealth allows the test officer to literally fly around and view the simulation without interfering with the action in the simulation. The stealth is a passive device, having special flight modes which make it the fastest and most maneuverable vehicle on the database. Stealth features allow the observer to view the battlefield from a variety of perspectives. These include a tethered view which allows the user to follow, unnoticed; an individual vehicle, mimic view, which places the user in the vehicle and provides the same view as the vehicle commander; an orbit view which allows the operator to remain attached to a vehicle on the database and revolve 360 degrees still maintaining the vehicle as a center point of view; and the free fly mode, which replicates independent 3-way movement on the battlefield.

The Stealth system is a viewing platform that consists of a plan view display (PVD), an IBM compatible PC with a touch screen, a "Space Ball" data input device, and three 50 inch screen viewers, providing the operator a panoramic view of the battlefield. The stealth is driven by an MC5600 MASSCOMP computer. Its graphics are generated from a BBN 120TX/T image generator or, preferably, a GT 101 image generator (which eliminates the requirement for the MASSCOMP).

## **2.2 ADST Sites.**

There are three main ADST sites, including the Mounted Warfare Test Bed (MWTB), Fort Knox, KY, the Aviation Test Bed (AVTB), Fort Rucker, AL, and the Program Management Office (PMO) and Software Development Facility (SDF) in Orlando, FL. In addition, the ADST Program provides field engineering support for the Institute for Defense Analysis (IDA), located in Reston, VA.

### **2.2.1 Fort Knox Mounted Warfare Test Bed (MWTB).**

The Fort Knox Mounted Warfare Test Bed (MWTB) is a distributed simulation consisting of several local area networks (LANs). Each LAN is an Ethernet linking several simulators, workstations or smaller networks. The simulation can consist of either manned simulators that replicate specific combat vehicles such as the M1A2 main battle tank, or computer generated forces that model a particular vehicle or combat organization. The MWTB is separated into four basic operational areas: the simulator bay, the data collection and analysis area, the maintenance room, and the administrative offices. Refer to Figure 2.2.1-1 for the layout of the MWTB and to Figure 2.2.1-2 for the MWTB functional diagram.

### Mounted Warfare Test Bed

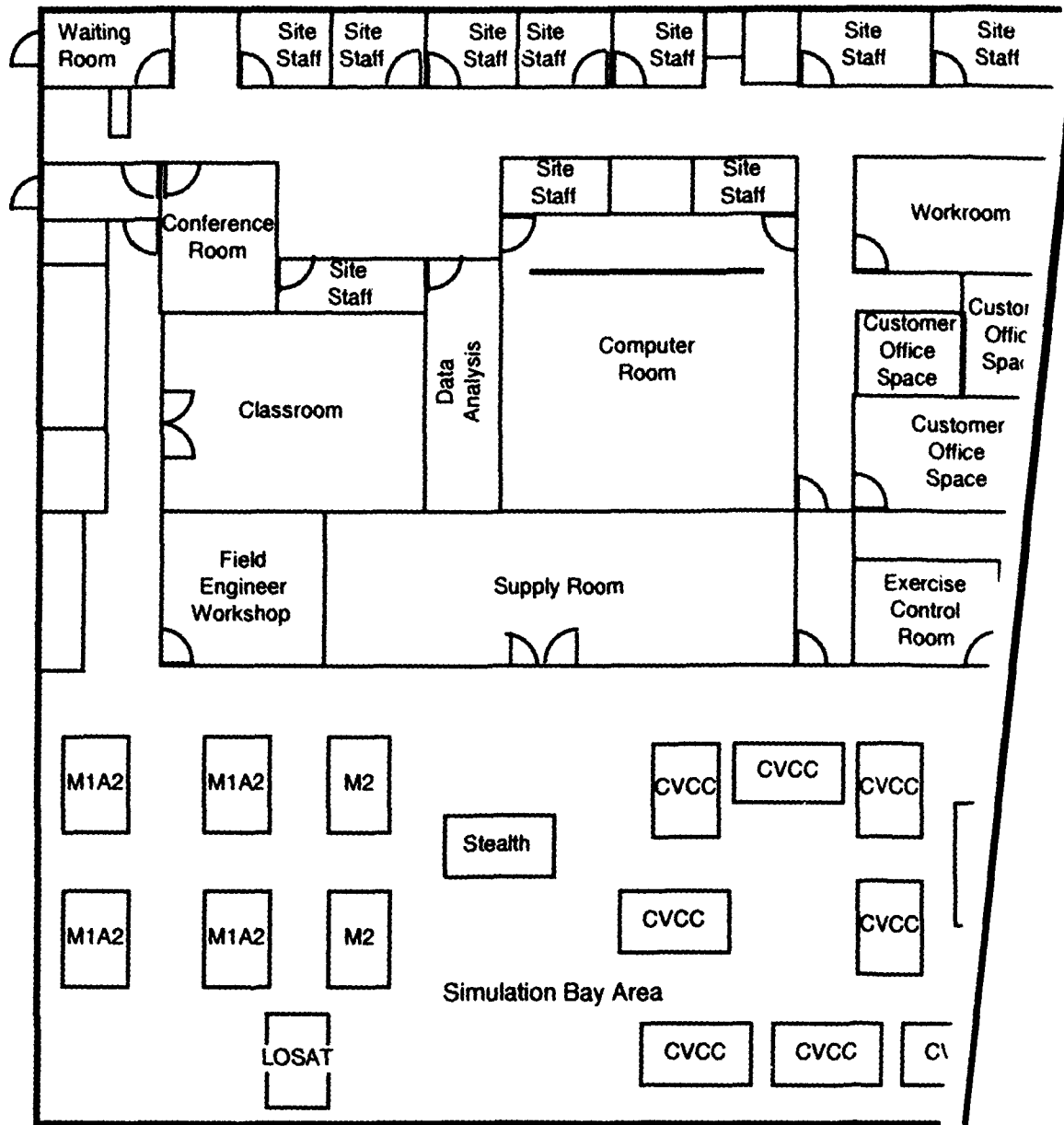

Figure 2.2.1-1. Mounted Warfare Test Bed Facility Layout

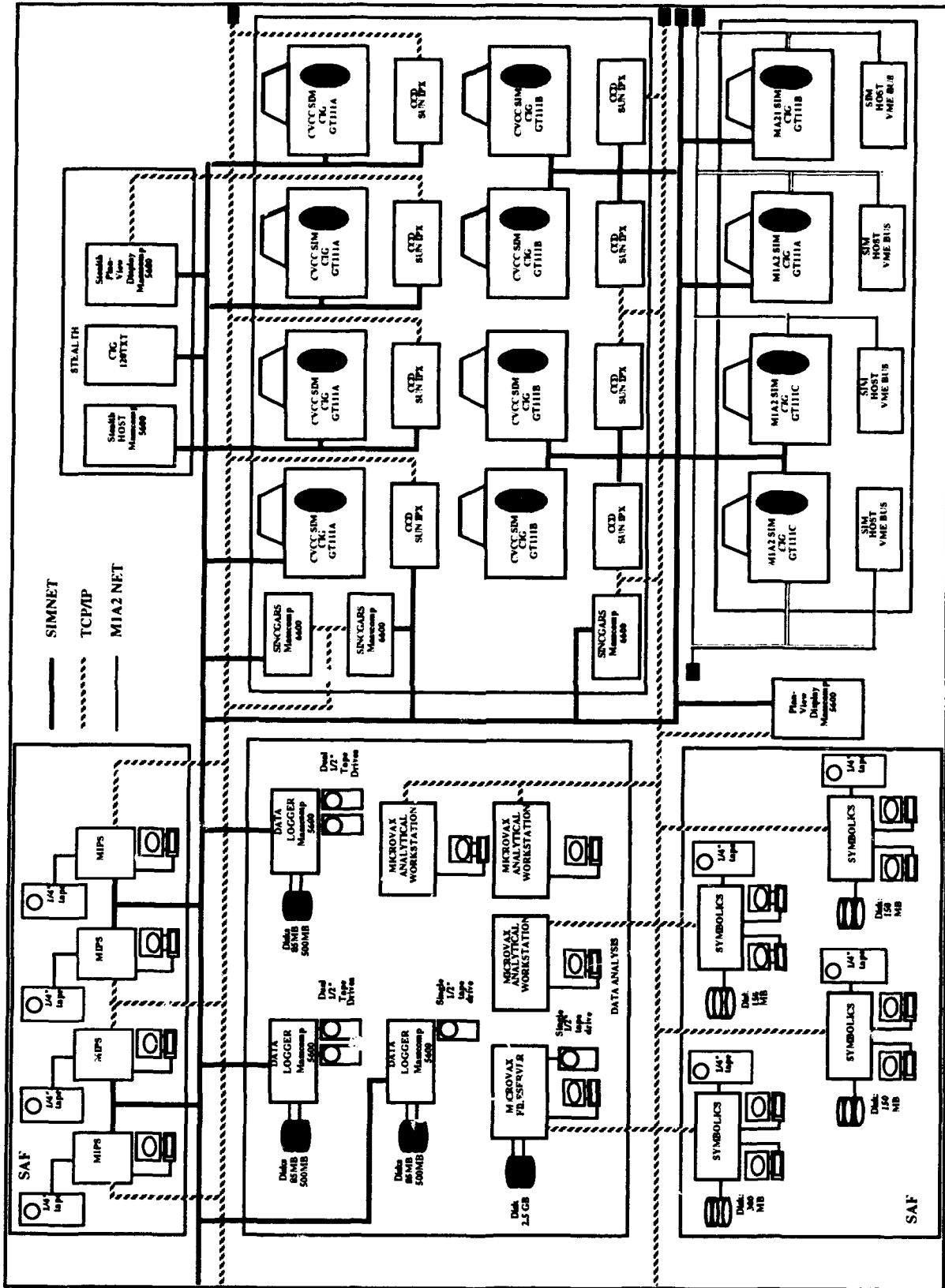

Figure 2.2.1-2. Mounted Warfare Test Bed Functional Diagram (2 of 2)

The simulator bay houses the simulators and associated equipment used in the research efforts. It operates on a 208 volt three phase overhead power bus, with 24 drop line locations for providing power to the simulators. The Ethernet and radio tray run parallel to the power bus. The three lines are color coded providing easy recognition of the individual systems. A computerized environmental control unit monitors and adjusts the temperature and humidity throughout the building, maintaining an environment conducive to the optimum function of this highly computerized operation. Several uninterrupted power source outlets are located throughout the bay. These outlets are primarily used for powering automated data collection equipment which is sometimes operated in the bay instead of the computer room. Two rooms, one at each end of the bay, can be configured for experimental control operations. Test officers will often establish their test control operation in one of these rooms in order to segregate the test participants from the simulation operators and data collection personnel. This provides a more secure evaluation and minimizes the potential for data contamination during the test.

The Maintenance area contains the tools, spare parts, and work space necessary to ensure efficient operation and conduct repairs on all electronic components in the facility. The maintenance operation routinely conducts repairs down to board level, and occasionally down to component level. The maintenance area consists of two rooms: a technician's work room and a storage room. The storage room contains spare parts, consumables, reconfigurable simulator components, and a small simulator fabrication shop.

Administrative offices house personnel who provide resource scheduling, supply requisition, personnel management, security, and safety services as an integral part of the operation of the MWTB. Administrative functions are accomplished by coordinating operations and schedules among the site staff, various clients, and the U. S. Army Technical Oversight Representative (TOR). A communications net enhances communication not only within the confines of the site, but throughout the ADST network of facilities. The Electronic Information Exchange Network (EIEN) has provided an enhanced method of communicating throughout the ADST world, creating a setting for speedy resolution of problems.

The facility currently houses 15 simulator shells: 8 CVCC simulators, 4 M1A2 simulators, 2 M2/3 simulators, and 1 LOSAT simulator (see Table 2.2.1-1). At present, there are not enough computer image generators in the facility to power all simulators. The CIGs used in this facility are GT-111s, which have eight low resolution channels and one high resolution channel, creating a total of nine possible channels for image generation. The recently acquired

M2/3s are configured to use the 120T/Butterfly CIG, which have eight low resolution channels and no high resolution channels.

Table 2.2.1-1. Major Equipment at the MWTB

QUANTITY	DESCRIPTION
4	M1A2 Simulators
8	CVCC Simulators
2	M2/3 Simulators
1	LOSAT Simulator
1	STEALTH
2	Shadow Box
4	SAFOR
4	PVD
3	MCC
1	Long Haul Net
2	Dual tape data logger
1	Single tape data logger
1	Micro VAX data analysis equipment

- a. Terrain Databases. The simulation takes place on a computer generated virtual battlefield which is developed from a terrain database. Maps and charts are supplied. Databases being used include the NTC database, the SAKI database, the Bosnia database, the Fort Knox database, and the Fort Hunter-Liggett database. A complete list of the available databases can be found under Terrain and Sensor Databases.
- b. Long Haul Gateway. A Long Haul Gateway is installed in the MWTB. It consists of a BBN T20 connected to a T-1 telephone line capable of channeling one and a half megabits of data per second. The BBN T20 is capable of including eight voice channels along with the simulation PDU traffic. Through this system, the analog voice is digitized at the sending end and converted back to analog at the receiving end. This allows separate sites to simultaneously interact with each other on the same terrain.
- c. Gateway Security. Fort Knox is in the process of installing a secure gateway to support encrypted long haul exercises.
- d. Data Logging. As a test or simulation is being run, the data is transmitted over an Ethernet in a series of packets or protocol data units (PDUs). These PDUs are normally recorded on any one of three data logger MASSCOMP 5600 data recorders located in the computer room. The data is normally recorded on 9-track tape and then analyzed on a VAX cluster comprised of workstations and a Micro VAX file server. The analysis is not slaved to the simulation and can be accomplished while another

simulation is running. Analysis results can be provided to the user in the form of hard copy data and graphs, 9-track file tapes, cassette tape, or diskettes.

- e. **Data Analysis.** The Loral team on-site staff has expertise and years of experience in designing, conducting, evaluating, and reporting experiments in Distributed Interactive Simulation. This staff includes programmers and field engineers who have the technical knowledge required to assemble simulators and test networks designed to answer a customer's questions. It also includes research scientists, training developers, systems analysts, and data technicians who can plan, conduct, and analyze the results of these experiments. Finally, it includes operations specialists and subject matter experts with military backgrounds who can ensure that the experiments are conducted in a manner which is doctrinally sound.

### **2.2.2 Fort Rucker Aviation Test Bed (AVTB).**

The Aviation Test Bed (AVTB) is the aviation component of Battlefield Distributed Simulation-Developmental Technology and provides Department of Defense agencies with an aviation-oriented, research development test and evaluation (RDT&E) facility consisting of aviation, armor, infantry, air defense artillery, and non-line of sight missile systems simulation devices. The AVTB is sponsored by STRICOM and the United States Army Aviation Center and is a government-owned, contractor-operated facility.

In a training development role, the AVTB serves as a joint and combined arms, collective task trainer and provides real-time simulations which replicate battle at each tactical echelon, team through brigade-level, inclusive of combat, combat support, and combat service support functions. In so doing, the AVTB allows users a means to experiment with training strategies and collective task accomplishment in a professional, cost-effective, and safe environment.

In the RDT&E capacity, the AVTB provides users with a cost effective, pre-prototype development, systems modeling facility. Ultimately, users can simulate before they build, buy, or fight a particular combat system. The site provides an environment in which users can explore the capabilities that should be incorporated into a new system, investigate the numbers and allocation of the system that achieve optimum performance on the battlefield, and determine the best means to employ the system once it is built. It provides a research laboratory for doctrine, force structure, materiel acquisition, and training and leadership development.

The complex offers users an environment with visitor office space; administrative support; a conference room; a classroom with TV/VCR, overhead and 35mm slide projection capabilities, and stealth functions; a student break area; and two tactical operations centers complete with requisite maps, charts, and radio communications. The site also offers a real-time data reduction and analysis center and is an approved classified (secret-level) processing facility. Additionally, the site contains a Video/Audio Data Production Center (VADPC). The VADPC exponentially increases customer service capability by providing state-of-the-art video manipulation equipment. Specific capabilities include dubbing, editing, splicing, and monitoring all standard and super VHS mediums. Cited capabilities are based on time stamp information synchronization for instant, frame-by-frame recall. The VADPC provides a new dimension in customized customer services and additional depth to simulation playback and after-action review activities.

In terms of manned and simulated device interface, all vehicle simulators and their supporting elements communicate via local area and long haul networks. Simulators within the complex are linked via a 10 megabit per second Ethernet. The Ethernet is connected to a single long haul network by a gateway. Table 2.2.2-1 describes the major components of the AVTB.

Table 2.2.2-1. Major Equipment at the AVTB

QUANTITY	DESCRIPTION
1	Long haul network
2	Local area networks
2	AppleTalk™ networks
8	Rotary wing aircraft (RWA) simulation devices
2	Fixed wing air (FWA) simulators
2	M1 Abrams tank simulators
2	M2/M3 Bradley Fighting Vehicle (BFV) simulators
1	Stealth vehicle with logging, playback, and VCR recording capabilities
2	Plan view displays (PVD) powered by Massachusetts Computer Corp. (MASSCOMP™) 5600 computers
4	Semi-automatic forces (SAFOR) workstations
4	Generic air defense simulators
2	Non-line of sight (NLOS) /fiber-optic guided missile (FOG-M) simulators
2	Management command and control systems (MCC)
2	Simulation networking control consoles (SCC)
1	Close air support (CAS) Macintosh® workstation
1	Fire support Macintosh workstation
1	Combat engineer Macintosh workstation
1	Administration and logistics Macintosh workstation
1	Maintenance Macintosh workstation
2	Data loggers powered by MC5600 MASSCOMP computers
8	Bolt, Baranek, and Newman (BBN) GT-111 computer image generators (CIGs)
4	BBN GT-101 CIGs
1	Micro VAX 3600 Computer for data analysis
1	Video/Audio Data Production Center
2	T1 Terrestrial Wideband Gateways
1	Encrypted Longhaul System
1	Video Teleconference System
2	56 kilobyte Lines
1	PC SAS Data Output Terminal

For introductory purposes, all vehicle simulators and their supporting elements communicate via local area and long haul networks. Simulators within the complex are linked via a 10 Megabit per second Ethernet. The Ethernet is connected to a single long haul network by a gateway.

In addition to the aforementioned components, the complex offers users with limited office space; limited administrative support; a conference room; a classroom with TV/VCR, overhead



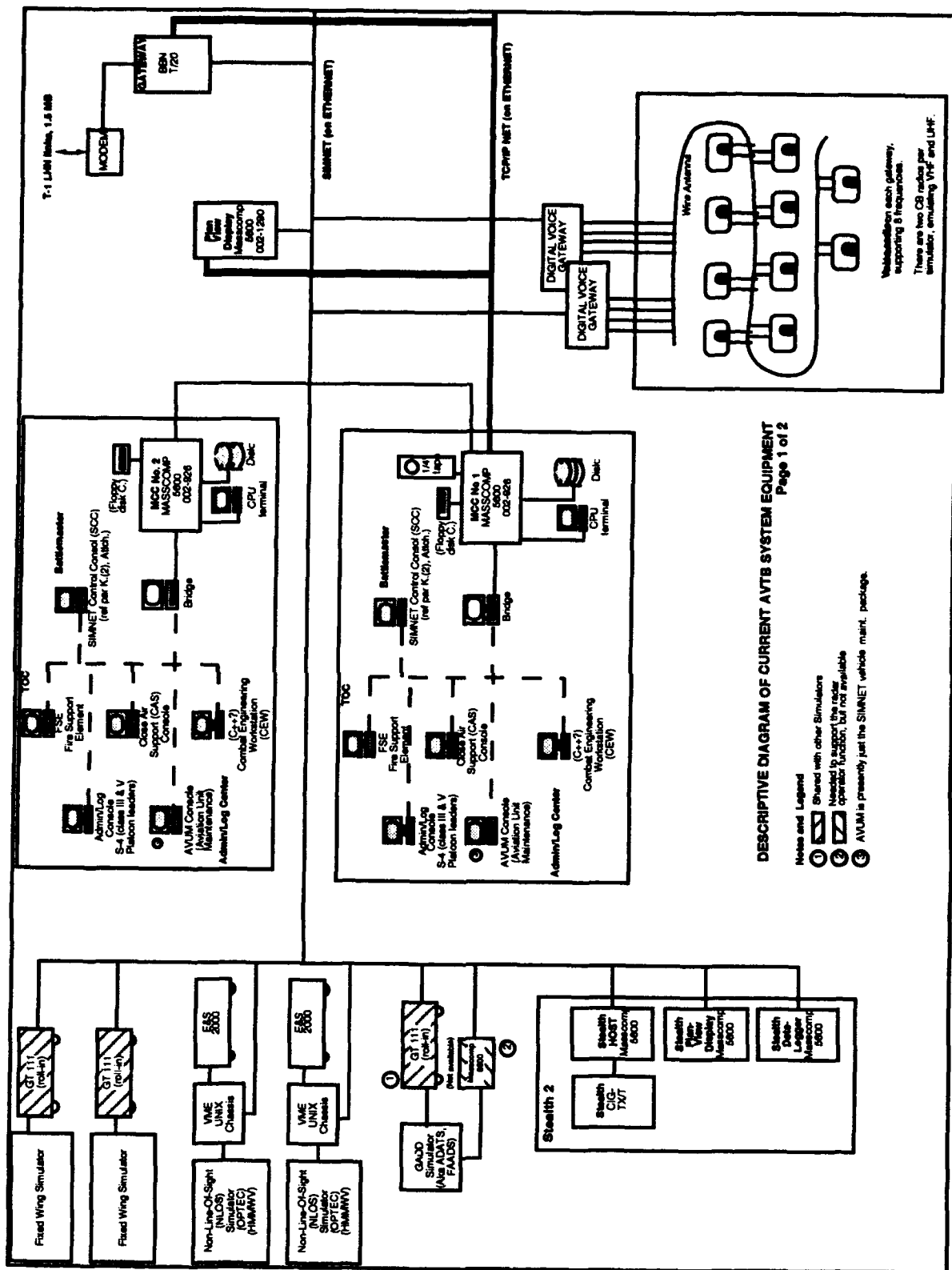

DESCRIPTIVE DIAGRAM OF CURRENT AVTB SYSTEM EQUIPMENT  
Page 1 of 2

- Notes and Legend
- ① Shared with other Simulators
  - ② Needed to support the radar operator function, but not available
  - ③ AVJM is presently just the SIMNET vehicle maint. package.

Figure 2.2.2-2. Aviation Test Bed Functional Diagram (1 of 2)

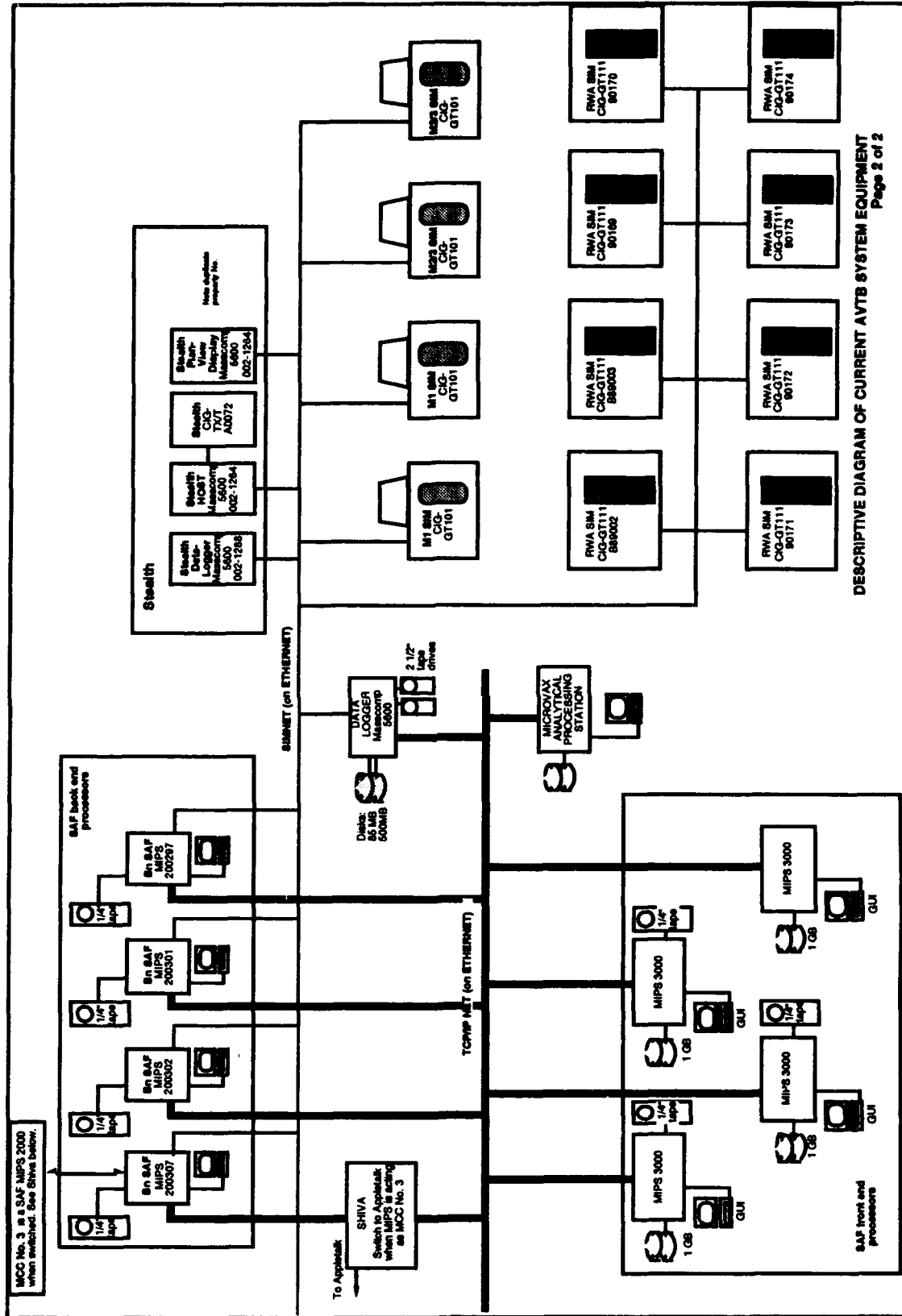

DESCRIPTIVE DIAGRAM OF CURRENT AVTB SYSTEM EQUIPMENT  
Page 2 of 2

Figure 2.2.2-2. Aviation Test Bed Functional Diagram (2 of 2)

- a. **Tactical Communications.** The AVTB uses a combination of hard-wired citizen band radios and army telephones (TA-312) to effect tactical communications for both research and development and training development requirements. Requisite command and control, combat, combat support, combat service support, and administrative communication networks are facilitated in the manner. A communications diagram is provided in Figure 2.2.2-3.
- b. **Data Analysis.** Data analysis is performed using a DEC Micro VAX 3600 Computer with VMS operating system and RS/1 and DataProbe extraction and analysis software. Data recorded on the data logger is transferred by 1/2" magnetic tape to the Micro VAX where it is processed, producing tabulated data, which can then be manipulated in a variety of ways, including x-y graphs, bar graphs, and pie charts. Additionally, an IBM-clone 486-33 microcomputer is networked with the Micro VAX, allowing data output in a number of other formats, to include ASCII, SAS, Lotus, and Dbase III+. Turnaround time for hard copy data output is 4-48 hours, depending upon the size of the dataset and the complexity of the processing. Data output can also be exported via a number of media, including 3-1/2" and 5-1/4" diskettes, 1/2" magnetic tape, 1/4" (9-track) tape cassettes, 8mm tape cassettes, or 90-MB Bernoullis. The site has an assigned Research Analyst who provides test design consultation. The real-time data analysis function is provided by the Plan View Display and Stealth devices, which are monitored by trained observers. Such data (to include full voice recording) can also be captured via in-cockpit cameras, FLIR monitors, and non-interactive playback, all of which may be recorded to VHS videocassette. On-site personnel can additionally provide a full spectrum of test design and development and modeling consultation services.



The ADST Software Development Facility, shown in Figure 2.2.3-2, consists of four principal laboratories and supporting work areas, including:

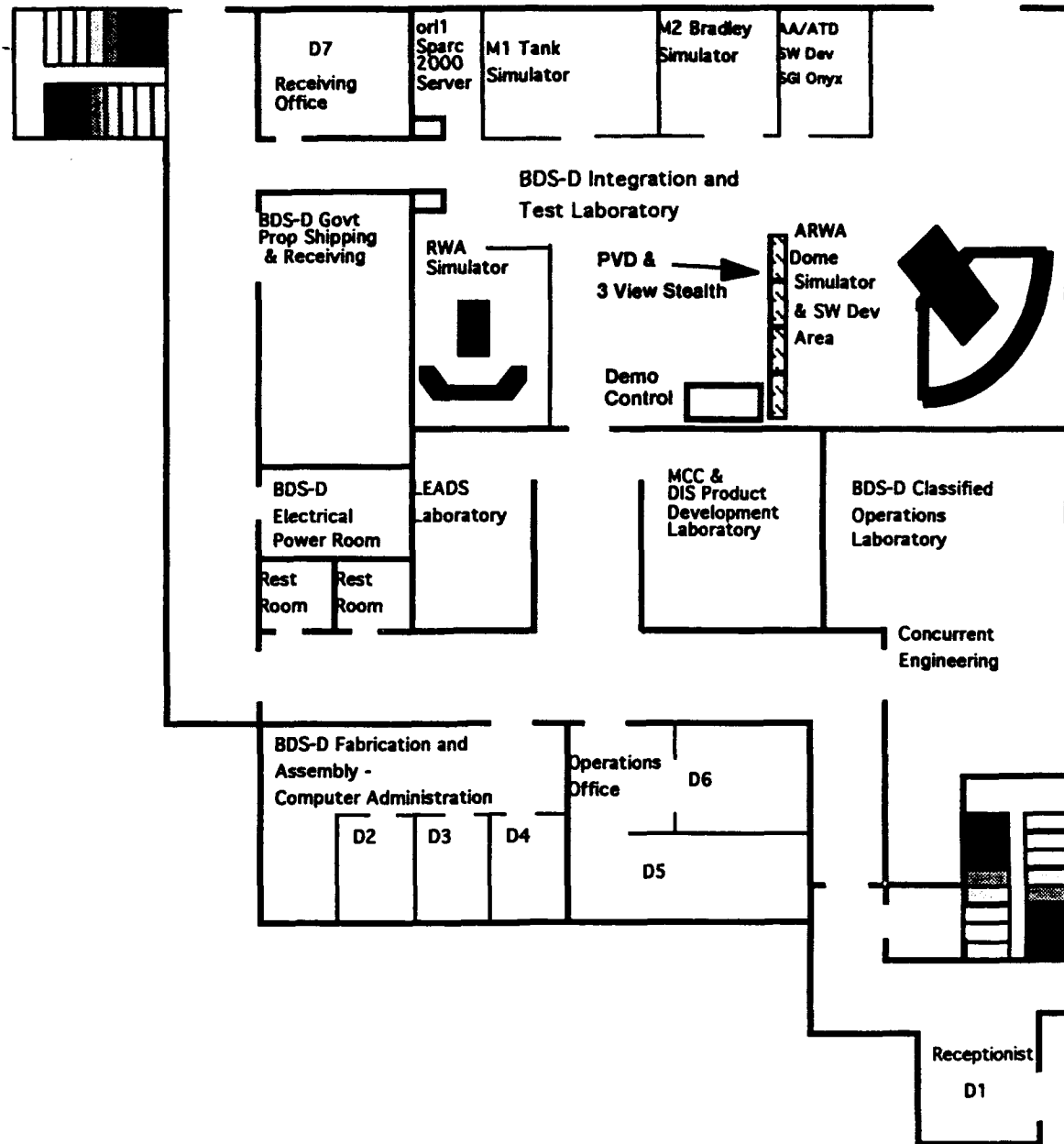

Figure 2.2.3-2. ADST/BDS-D Software Development Facility

- a. BDS-D Integration and Test (I&T) Laboratory. This laboratory consists of a 2000SF highbay (22ft clear) fully networked and reconfigurable area designed to accommodate both current SIMNET and next generation DIS simulators and supporting computer configurations. Presently this laboratory supports a SIMNET M-1 Tank Simulator; a

SIMNET M-2 Bradley Fighting Vehicle Simulator, a SIMNET Rotary Wing Aircraft (RWA) Simulator; a DIS-based Advanced Rotary Wing Simulator (ARWA); and SIMNET Plan View Display, SAFOR, and Three View Stealth Displays. In addition, this laboratory also provides space for computer systems used to development both the ARWA and Anti-Armor Advanced Technology Demonstration (A2/ATD) Delivery Orders. The I&T Laboratory also contains the ADST Multi-processor SparcCenter 2000 Software Development Server. The I&T Laboratory supports both E-Net and FDDI devices.

- b. DIS Products Development Laboratory. This laboratory is a 450SF facility dedicated to the development and testing of DIS products, such as the Cell Adapter Unit( CAU), Cell Interface Unit (CIU), ModSAF and Protocol Data Units (PDUs). The major systems contained in this laboratory include a Sparc 10 computer running Cell Adapter Unit software used to interface DIS and SIMNET devices; a 486 PC computer running DIS Cell Interface Unit software; and a ModSAF configuration hosted on an SGI platform.
- c. Loral Experimental and Developmental Simulation (LEADS) Laboratory. This laboratory, which is approximately the same size as the DIS Products Lab, provides T-1 level DIS long haul connectivity with other Loral facilities such as LADS Cambridge and Bellevue; WDL, San Jose; Space and Range, Sunnyvale; Advanced Projects, Reston; and Vought Missile Systems, Dallas. It is being funded and equipped through the Loral Corporate LEADS Capital project for use as a simulation technology development and demonstration facility. Once completed, this laboratory will complement and extend the overall SDF long haul networking capability.
- d. Classified Operations Laboratory. This laboratory occupies approximately 1200SF of the SDF and provides the capability to conduct classified experiments through the SECRET/Special Access level. Entirely self-contained, it has its own Fiber and E-Net networks, environmental system, and security system, and provides the same level of classified operations support as was previously available in San Jose.
- e. System Fabrication and Assembly Area. This area occupies approximately 600SF of the SDF and provides space for fabrication, assembly, and test of simulators and their subsystems. This area also provides component repair facilities and space for SDF Computer System Administration functions and equipment.
- f. Other SDF Facilities. The SDF also contains space for Program Operations Management, GFE storage, shipping and receiving functions, and the facility main electrical power supply.



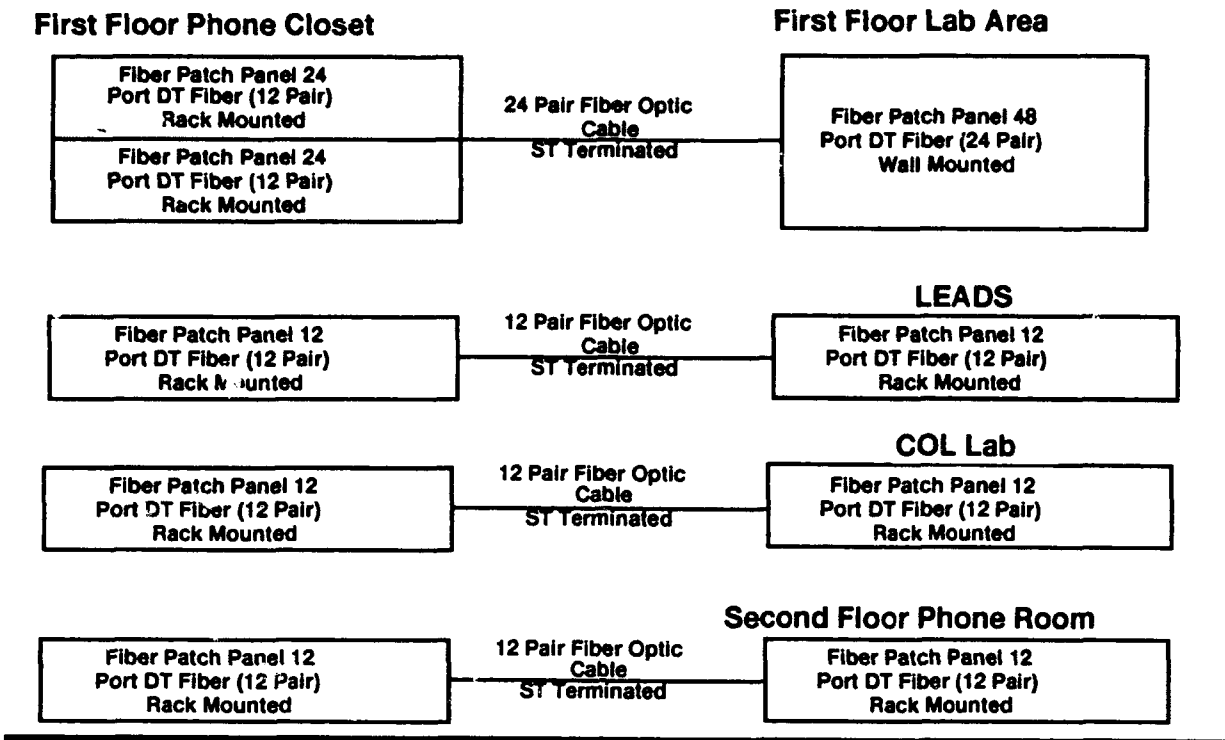

Figure 2.2.3.1-3. SDF Fiber Optic Network Distribution

#### 2.2.4 Institute for Defense Analysis (IDA).

The ADST program supports the Institute for Defense Analysis (IDA) with operations and maintenance support. The IDA facility is a demonstration site and a development facility for improving and enhancing distributed simulation technology. A diagram of the IDA system configuration is shown in Figure 2.2.4-1.



## **2.2.5 Interfacing Sites.**

This section discusses those sites which ADST either currently interacts or plans to interact with.

### **2.2.5.1 MULTIRAD (Williams AFB).**

The MULTIRAD Delivery Order is an important element of the Advanced Distributed Simulation Technology Contract because it provides for networked extensions to Air Force weapon systems as part of the networked simulation battlefield environment. Elements represented include both fixed wing, F-16 and F-15, Airborne Radar AWACS, as part of the DoD networked simulation assets. The ongoing Network Interface Unit (NIU) development is particularly important in interfacing dissimilar fidelity simulators and is a prototype for the DIS Cell Adapter Unit (CAU). The linking of existing simulation assets utilizing NIU capabilities is critical for affordable simulation network extensions.

The MULTIRAD Delivery Order contains the support of the MULTIRAD Network and the DMSO Close Air Support Tasks.

To conduct the required multi-ship training research, network analysis, and aid the development of simulator networking standards, the local area and long haul MULTIRAD network capability will be improved and expanded at the Armstrong Laboratory Aircrew Training Research Division at Williams Air Force Base, AZ. Figure 2.2.5.1-1 represents the existing MULTIRAD network.

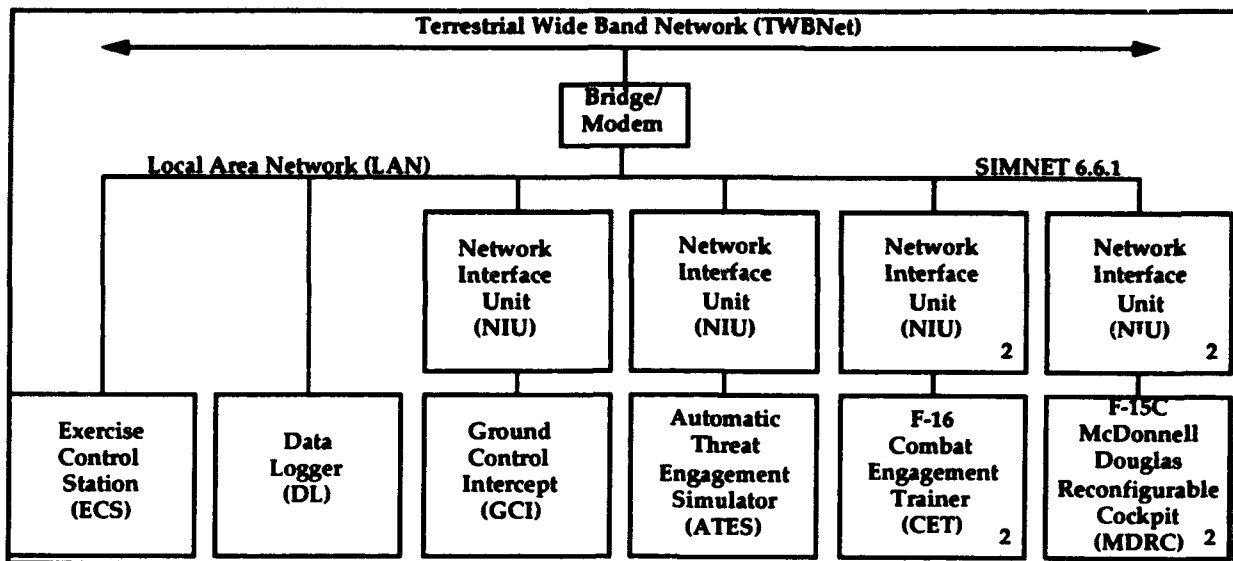

Figure 2.2.5.1-1. MULTIRAD Network Diagram

#### 2.2.5.1.1 Network Interface Unit (NIU) Enhancements.

A new Fiber Distributed Data Interface (FDDI) NIU with pSOS operating system will be implemented on a token ring fiber optic Local Area Network (LAN). To support larger exercises with more entities on the network, improvements to the performance of the NIU will be made. To accommodate devices that generate 100 entities or more, and for individual simulators to process the data of hundreds of entities, parallel processing, faster processors, and/or improved software design will be implemented.

#### 2.2.5.1.2 Network Communication Protocol.

The development of network protocol extensions to support the research requirements of the Air Force and support the development of DoD/Industry standards for Distributed Interactive Simulation (DIS) will continue. The NIU software complying with the Protocol Data Units for Entity Information and Entity Interaction in a Distributed Interactive Simulation will be developed. As the standard evolves, continued monitoring of changes to the standard, influencing modifications to the standard, and implementation of those changes into the NIU design will be made. The goal is to achieve 100% compatibility with all standards for DIS; however, deviations from or extensions to the standard may be implemented to meet the MULTIRAD research requirements.

#### **2.2.5.1.3 Long Haul Network (LHN).**

In cooperation with DoD agencies, the Defense Simulation Internet (DSI) and/or other wide area networks to support research requirements for long haul networking will be used. Systems engineering for requirements analysis, systems integration, specification generation, configuration management, network interface control, test and evaluation, and documentation for any sites on the LHN will be performed. The LHN will provide the capability for multi-ship training evaluation, network performance assessment, and protocol testing using a secure LHN.

#### **2.2.5.1.4 Close Air Support.**

Nodes for the DMSO Close Air Support effort, as agreed upon by the Air Force and DMSO, will be established. The current plans are to use existing nodes on the DSI in combination with dedicated T1/KG-94 connections. The establishment of dedicated long-haul connections, providing and integrating NIUs, and providing operating instruction and training to remote site locations will be provided. The sites are expected to include a ground component, and an air component, a laser target designator, and a command and control component. Other government/contractor sites are expected to be added which will require additional NIUs and integration effort.

#### **2.2.5.2 CSRDF (NASA-Ames).**

The goal of Battlefield Distributed Simulation-Developmental (BDS-D) is to satisfy the U.S. Army and DoD need to conduct experimental test and analysis in support of decision-making for force modernization, such as force and organizational design, doctrine and training development, material requirements definition and documentation, operational testing and evaluation, and material development and acquisition.

A task inherent in this goal is to maximize use of existing and proposed engineering simulators and simulations by making them interoperable among themselves and with BDS-D. By interconnecting the Crew Station Research & Development Facilities (CSRDF) and the AVTB facility at Fort Rucker, the issues related to the linking of these engineering simulators and BDS-D simulators will be examined. Alternative technical approaches will be analyzed and solutions will be implemented compatible with the Distributed Interactive Simulation (DIS) Standard 1.0 of October 30, 1991. Distributed Interactive Simulation (DIS) architectural

design and standards will be assessed and documented and, if warranted, submitted to the appropriate working groups for inclusion in DIS Version 2.0.

This linkage is a cooperative effort among the U.S. Army, DARPA, and the U.S. Navy. Each is aggressively pursuing interoperable simulation as a highly leverage able technology to significantly enhance combat readiness as well as system acquisition. Each has a defined role in this linkage, and success is dependent on the cooperation among the three Government groups and their respective contractors.

The CSRDF / BDS-D project has two phases. Phase 1 is the specification development and linkage implementation phase. After development is completed and the linkage is established, Rotorcraft Pilot Associate (RPA) evaluations will begin. Phase 2 is for the testing with RWA and for further RPA development. The RWA interface specification, design, and implementation is included in Phase 1.

The following identifies those elements of the CSRDF (NASA Ames) / BDS-D (Fort Rucker), interface task that are the responsibility of STRICOM and are to be executed by Loral. The interface will provide several services.

- a. Application Interface Service. The link will support the real-time information exchange using DIS 1.0 between the CSRDF single-mission simulators at NASA Ames and the AVTB multi-mission battlefield simulations at Fort Rucker.
- b. Network Protocol Services. The links will support the Communications Protocol used to transport DIS Protocol Data Units (PDU)s.
- c. Long-Haul Data Link Services. This provides the physical and logical wide band communications between sites.
- d. Correlated Database. This database contains terrain data and graphic models and is common between CSRDF and AVTB.
- e. Data Logger. This provides for recording, searching, and playing back packets that flow across the interface.

The development team includes STRICOM and Loral, NCCOSC (Naval Command, Control, and Ocean Surveillance Center) Research, Development, Test, and Evaluation Division Navy Research and Development(NRaD) and ETA, and U.S. Army Aviation and Troop Command (ATCOM) and CAE, the on-site contractor at Crew Station Research and Development Facility (CSRDF). Figure 2.2.5.2-1 illustrates the CSRDF/AVTB connectivity.

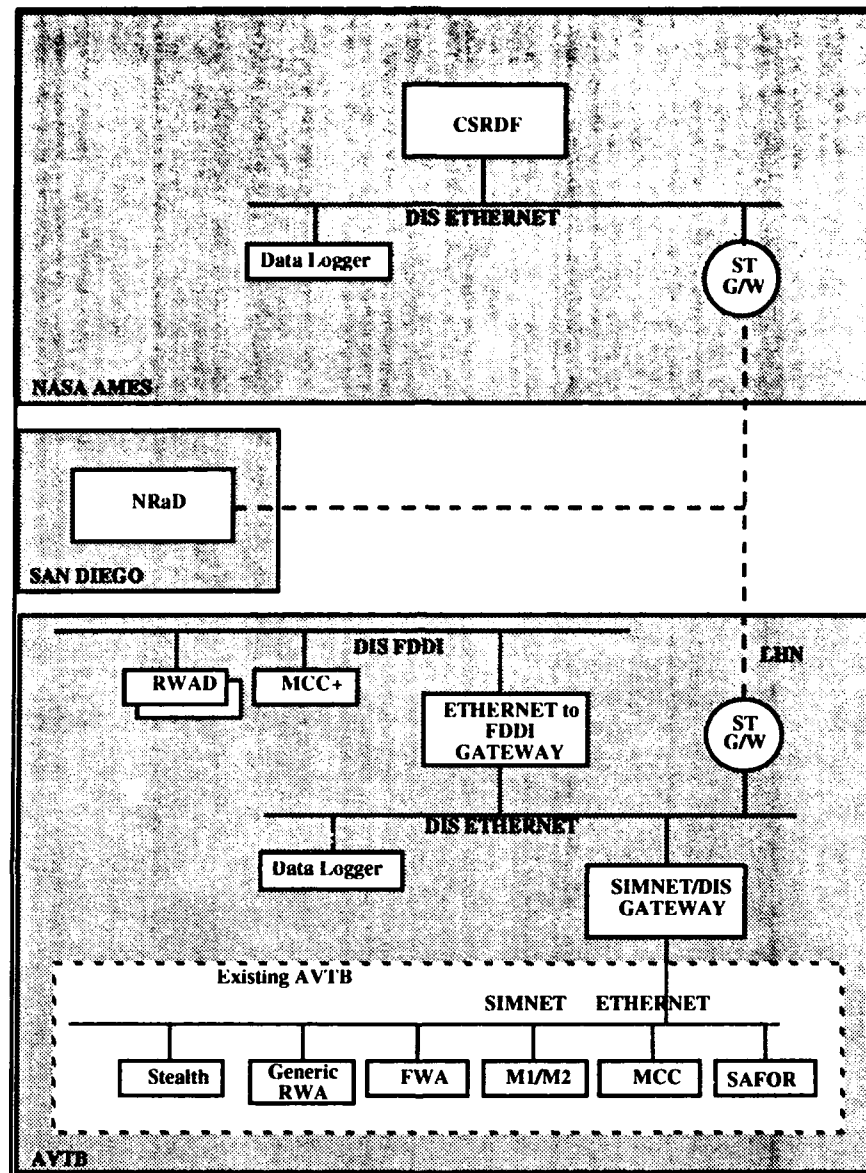

Figure 2.2.5.2-1. CSRDF/AVTB Connectivity Diagram

### 2.3. Site Interconnectivity.

The Electronic Information Exchange Network was established to enhance communication between ADST and the various communities (Government, academic, and industrial) involved in distributed simulation, as well as provide enhanced communication between the ADST sites.

The Electronic Information Exchange Network (EIEN) ECP has provided the hardware infrastructure which supports software engineering and electronic information exchange. The

EIEN has provided an enhanced method of communicating throughout major ADST sites. Figure 2.3-1 illustrates the network interconnections available to ADST and related activities. This network configuration also allows and enhances direct file transfer, file access and e-mail capability between ADST sites.

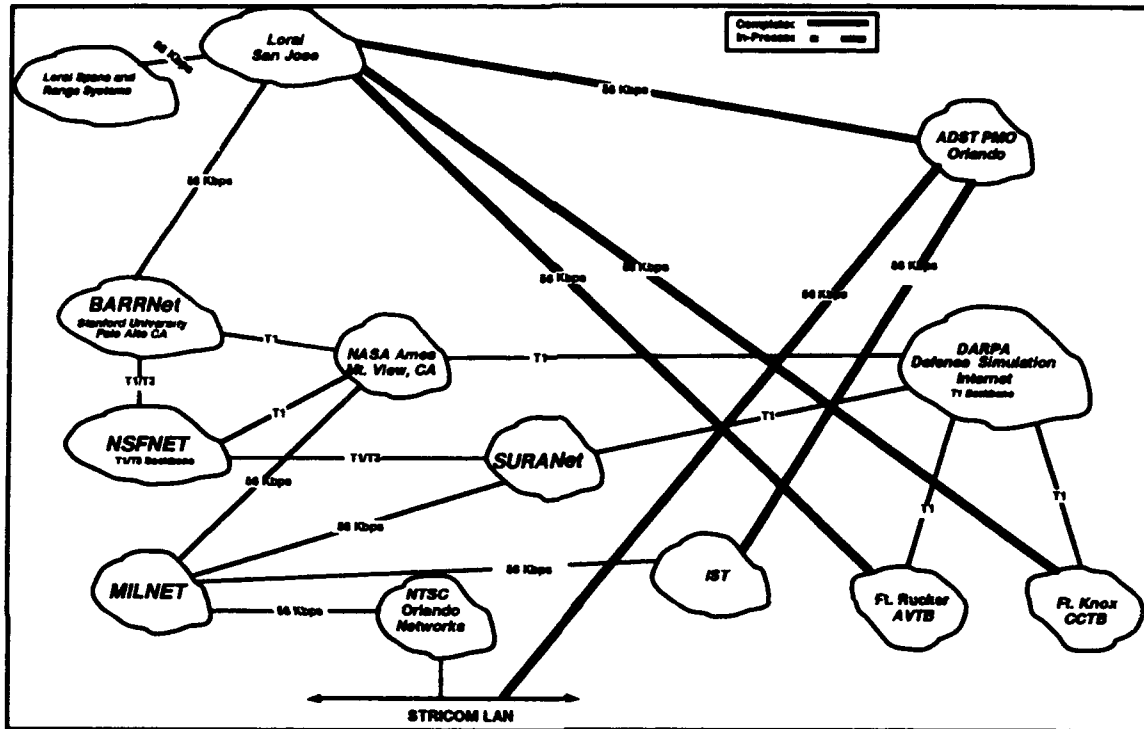

Figure 2.3-1. Network Interconnectivity

### 2.3.1 ADST Orlando Operations Connectivity.

As illustrated in Figure 2.3.1-1, the ADST office in Orlando has both Ethernet and AppleTalk networks installed based on Unshielded-Twisted-Pair (UTP) wiring. A Cabletron hub provides the interface for both Ethernet and AppleTalk communications in a single chassis. A Cayman Systems "GatorStar" provides connectivity between the AppleTalk and Ethernet for both TCP/IP and AppleTalk protocols. The GatorStar also provides file sharing via NFS to a SUN SPARCstation. A Cisco IR/M Remote Protocol Router provides the Wide Area Network (WAN) for the TCP/IP and AppleTalk protocols. A 56Kbps leased data circuit between ADST PMO and Loral WDL San Jose provides the connection to the rest of the EIEN and the Internet. The Cabletron chassis provides 802.3 Ethernet access as required for TCP/IP and

EtherTalk-based computer systems. An additional Cisco MGS router is to be installed to support the connection of IST to the EIEN.

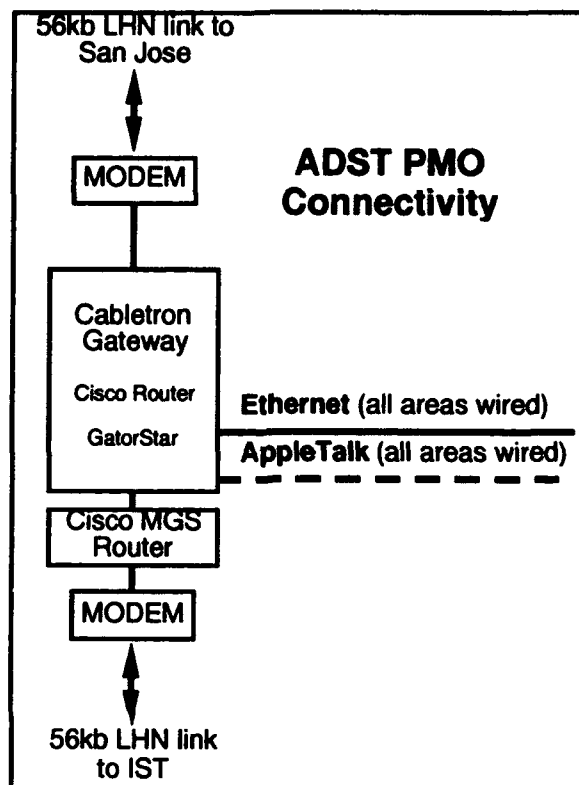

Figure 2.3.1-1. Orlando ADST PMO, EIEN Connectivity

### 2.3.2 San Jose Connectivity.

The Loral WDL San Jose node of the EIEN consist of a Cisco Systems AGS+ Multiprotocol router. This router connects to sites at Fort Rucker, Fort Knox, and Orlando.

### 2.3.3 IST Connectivity.

The Institute for Simulation and Training (IST) in Orlando, FL is connected to the ADST PMO office in Orlando via a 56Kbps data circuit and Cisco MGS routers. This allows TCP/IP-based data to be transferred directly without having to traverse the Internet.

### 2.3.4 Fort Rucker, Fort Knox Connectivity.

The equipment provided to these sites under the EIEN is shown in Figures 2.3.4-1 and 2.3.4-2. Fort Rucker and Fort Knox are connected to Loral WDL San Jose via 56Kbps leased data circuits and Cisco routers. This allows TCP/IP and AppleTalk-based data to be transferred directly without having to traverse the Internet. A Cayman Systems GatorBox CS at each site allows AppleTalk-based traffic to pass to the sites' Ethernet and then on to the WAN for transmission on the EIEN.

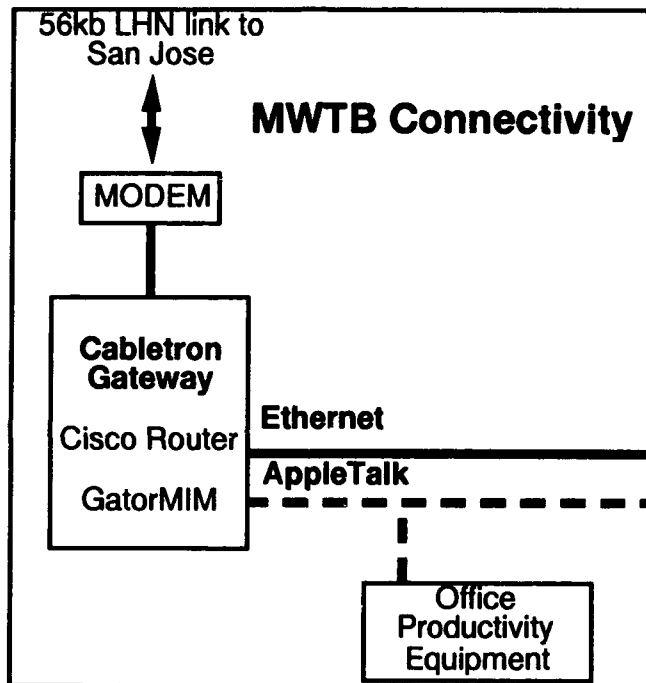

Figure 2.3.4-1. Fort Knox MWTB, EIEN Connectivity

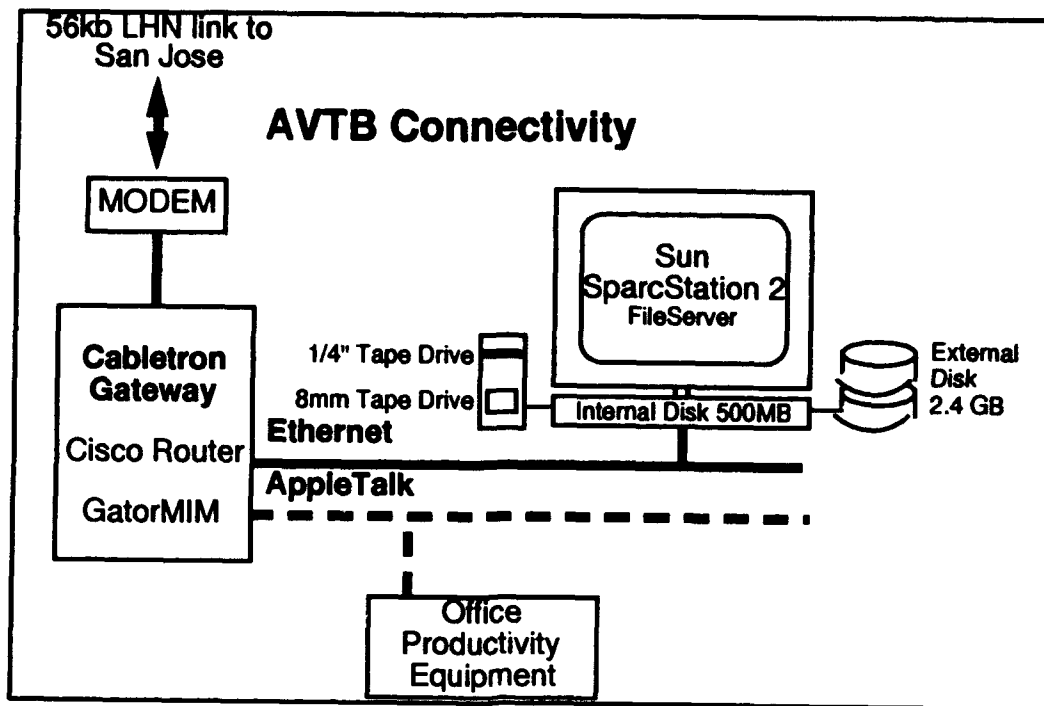

Figure 2.3.4-2. Fort Rucker AVTB, EIEN Connectivity

### 3 SOFTWARE.

At the start of the second contract year, the BDS-D system consisted of the application software and data that was running at the two BDS-D sites, Fort Knox and Fort Rucker (formally known as SIMNET D-Sites). The only source code that was available was from the STRICOM SIMNET library. This source code was incomplete and not the version running at any of the sites. Under the DARPA SIMNET Bridge Contract with BBN, a set of Software Design Documents, a complete set of source code and utilities, and a complete set of cold start procedures were scheduled to be delivered. This effort was terminated prior to the completion of these tasks. A set of Software Design Documents was delivered in June 1991. However, this set of documents reflected SIMNET Release 6.6.0 and not SIMNET 6.6.1, which was fielded to the SIMNET T-sites in early 1991. No source code or code start procedures were delivered.

- a. Documentation. Table 3-1 lists the SIMNET 6.6.0 Software Design Documents. As mentioned, this documentation set reflects SIMNET Version 6.6.0 and not SIMNET Version 6.6.1 that is currently fielded. Therefore, system additions and software problems fixed between Version 6.6.0 and 6.6.1 are not reflected in this documentation

set. The major differences between these versions are the addition of the Dismounted Infantry Simulator and the addition of Combat Engineers to the MCC.

Also, those SIMNET elements that were only fielded to the SIMNET D-Sites were not considered part of the formal SIMNET Version 6.6.1 release. Therefore, no Software Design Documents exist for RWA, FWA, NLOS, FAAD, RWA CTAS extensions, AVTB MCC, SINCGARS, CVCC, M1A2, or any other software that was developed for a particular test or experiment. While NLOS design documentation is not available, source code is available. The M1A2 simulators were developed by General Dynamics Land Systems (GDLS) and no source code or software documentation is available.

Table 3-1. SIMNET 6.6.0 Software Design Documents

<b>CSCI NUMBER</b>	<b>DOCUMENT TITLE</b>
1	Software Design Document MCC CSCI (1) Volume 1 of 2 Sections 1.0 - 2.18
1	Software Design Document MCC CSCI (1) Volume 2 of 2 Section 2.18.1 - 2.22
2	Software Design Document NOM CSCI (2)
3	Software Design Document PVD CSCI (3) Volume 1 of 2 Sections 1.0 - 2.11.3.1
3	Software Design Document PVD CSCI (3) Volume 2 of 2 Appendices
4	Software Design Document DL CSCI (4)
5	Software Design Document Vehicle Simulation CSCI (5) Volume 1 of 4 Sections 1.0 - 2.2.3.1
5	Software Design Document Vehicle Simulation CSCI (5) Volume 2 of 4 Sections 2.2.3.2 - 2.5.3.27.1
5	Software Design Document Vehicle Simulation CSCI (5) Volume 3 of 4 Sections 2.5.4 - 2.6.18.12.1
5	Software Design Document Vehicle Simulation CSCI (5) Volume 4 of 4 Appendices
6	Software Design Document SAF Workstation CSCI (6) Volume 1 of 2 Sections 1.0 - 2.4.3.86
6	Software Design Document SAF Workstation CSCI (6) Volume 2 of 2 Sections 2.4.3.4.87 - 2.9.7 and Appendices
7	Software Design Document SAF Parameter Editor CSCI (7)
8	Software Design Document SAF Simulation Host CSCI (8) Volume 1 of 2 Sections 1.0 - 2.7
8	Software Design Document SAF Simulation Host CSCI (8) Volume 2 of 2 Sections 2.7.1 - 2.15
9A	Software Design Document CIG Host CSCI (9A)
9B	Software Design Document GT Real-Time Software Host CSCI (9B) Volume 1 of 2 Sections 1.0 - 2.12.19.2
9B	Software Design Document GT Real-Time Software Host CSCI (9B) Volume 2 of 2 Sections 2.12.20 - 3.2 and Appendices

Table 3-2 describes the version of each CSCI as it relates to SIMNET Version 6.6.1.

Table 3-3 describes the current version each CSCI that was not part of the formal SIMNET Version 6.6.1 release.

Table 3-2. CSCI Versions for SIMNET Version 6.6.1

CSCI #	CSCI NAME	SIMNET 6.6.1 CSCI VERSION	COMMENTS
1	MCC	6.5.3	include Combat Engineers
2	NOM	N/A	
3	PVD	4.2	
4	Data Logger	6.6.3	
5	Vehicles	6.6.1	
6	SAF Workstations	10.7	
7	SAF Parameter Editor	N/A	
8	SAF Simulator Host	3.10.3	3.10.6 fielded to D-sites
9A	CIG Host	GTOS 4.7	GTOS 4.5 used on CVCC simulator at Fort Knox
9B	GT Real-time SW Host	rt5.7	rt5.5 used on CVCC simulator at Fort Knox
	Dismounted Infantry	2.0	

Table 3-3. Current Versions of Other CSCIs

CSCI NAME	LATEST VERSION
ADATS	N/A
CVCC	6.6.0
FWA	1.2.1
MIA2	1.0
NLOS	N/A
RWA	1.2.1
RWA CTAS	N/A
SINCGARS	2.0

- b. Source Code. Since the implementation of the Software CCP to the LSE in June 1992, Loral has been developing Version Description Documents (VDDs), Cold Start Procedures (CSPs), and certain other documentation useful to the customer and engineering communities in understanding and using SIMNET code for current developmental and experimental purposes. The CCP effort also provides fully baselined and configuration managed source and executable code for distribution to the DIS community. A more detailed discussion of the ADST Configuration Management (CM) process and current status of the ECP software baselining and documentation effort is provided in Section 4.1.

Through the Software Support CCP, the SIMNET source code was delivered to ADST. The initial delivery of software is summarized in Table 3-4. The source code was delivered on 150MB 1/4" cartridge tapes, with the exception of the MCC Macintosh workstation source code, which is on 3 1/2" DS, DD diskettes.

Table 3-4. Initial Source Code Delivery

TAPE OR DISKETT E	DESCRIPTION
Tape 1	rt5.5_gt4.7 for gt release 6.6.1
Tape 2	Knox3cow.001 - Database
Tape 3	gt-release M2-application
Tape 4	gt-release 6.6.1 DI-application
Tape 5	gt-release 6.6.1 Stealth-application
Tape 6	gt-release 6.6.1 M1-application
Tape 7	Source for MCC release 6.5.3 part of 6.6.1
Tape 8	Sources for MASSCOMP release 6.6.1 contains-M1 and Stealth
Tape 9	Sources for gt release of 6.6.1 contains - D1, M1, M2, and Stealth
Tape 10	Release 6.6.1 Logger src
Tape 11	PVD Source release for 6.6.1 pvd/common Tape 1 of 2
Tape 12	PVD Source release for 6.6.1 pvd/simnet pvd/tmp Tape 2 of 2
Tape 13	Masscomp 5600 MCC release 6.6.1 MCC Version 6.5.3
Tape 14	Masscomp 5600 Datalogger release 6.6.1 Make install_appl
Tape 15	Masscomp 5600 Stealth release 6.6.1
Tape 16	Masscomp M1 release 6.6.1/delta/simnet Includes CIG software
Tape 17	AVTB FWA and RWA application tape
Tape 18	AVTB FWA and RWA sources (Made on Sun)
Tape 19	Boot tape gtos4.7 and rtsw5.7
Tape 20	SAF Source code 3.10.6
Tape 21	SAF Coldstart comment source tape
Tape 22	SAF Coldstart Application source tape
Tape 23	SAF Coldstart Terrain Database tape (Knox)
Tape 24	SAF Coldstart Application Tape
Tape 25	SAF Coldstart System Tape
Tape 26	SAF Coldstart FEP Tape 1 (Geneva-7-2-color)
Tape 27	SAF Coldstart FEP Tape 2 (Geneva-7-2-color)
Tape 28	SAF Coldstart Distribution Tape 1 (Knox-terrain system)
Tape 29	SAF Coldstart Carry Dump tape
Tape 30	SAF Coldstart Distribution Tape 1 (map & saf system)
Tape 31	CVCC - gt - release includes - data files
Tape 32	CVCC - CITV source release
Tape 33	PVD release 6.6.1 includes - data files
Diskette	MCC 6.5.3 (Total of 3 diskettes) MAC Sources
Diskette	MCC 6.5.3 (Total of 8 diskettes) for MAC
Tape 34	M2 6.6.1 application tape including Butterfly Operating System and Tools
Tape 35	M2 Butterfly
Tape 37	libipc
Diskette	Missing Mac files

The source code and documentation are part of the ADST Technical Library.

Since the implementation of the ADST contract and initiation of the SWCCP, a significant number of both SIMNET and DIS-based software products have been developed. In some cases, such as the Data Logger, both SIMNET and DIS products now exist. Also, with the introduction of new hardware platforms at the ADST sites, versions of a number of these software products have been rehosted to run on the newer platforms, particularly SGI and SUN. The following section contains a brief discussion of each Computer Software Configuration Item (CSCI). Since formal configuration management has not been completed, the CSCI descriptions are based primarily on those given in the Software Design Document documentation set (refer to Table 3.1).

### 3.1 Data Logger (DL).

#### 3.1.1 Description.

The Data Logger (Figure 3.1.1-1) is a network management tool that captures the events of an exercise run over the network by recording Protocol Data Units (PDUs) sent by all network participants. An exercise can then be replayed from the information captured by the Data Logger. There are different versions of the Data Logger for both SIMNET and DIS protocols.

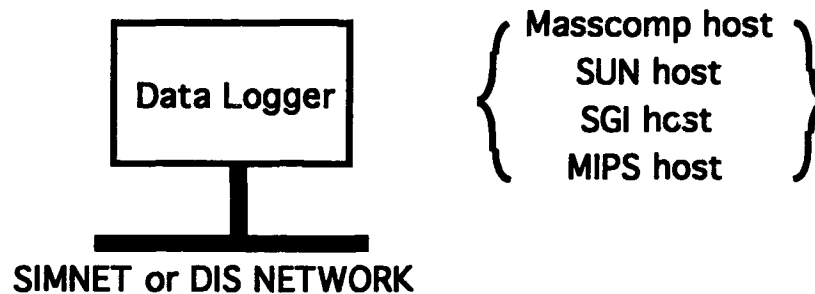

Figure 3.1.1-1. Data Logger Diagram

#### 3.1.2 Documentation.

- a. Cold Start Procedure (CSP) for the Data Logger (TR-93-003074).
- b. Version Description Document (VDD) for the Data Logger (TR-93-003073).
- d. Software Design Document for the Data Logger CSCI (June 1991).
- c. The Logger Interface User Guide (ModSAF).

### **3.1.3 Software.**

- a. Masscomp Real Time UNIX (RTU) Version 4.0A.
- b. BDS-D Data Logger 1.0.0 Source and Runtime Files (SIMNET, Masscomp host).
- c. BDS-D Data Logger 1.2.0 Source and Runtime Files (DIS, Masscomp host).
- d. ModSAF 1.0 Data Logger Source and Runtime Files (DIS or SIMNET, SGI and MIPS hosts).
- e. Logger 6.6.5 Source and Runtime Files (DIS, SUN, SGI, and Masscomp hosts).
- f. Logger 6.6.4 Source and Runtime Files (SIMNET, SUN, SGI, and Masscomp hosts).
- g. Architecture & Standards (AS) Data Logger Source and Runtime Files (DIS, SGI host).

### **3.1.4 Computer Software Configuration Item (CSCI) Breakdown.**

- a. Libraries Computer Software Component (CSC).
- b. Data Logger Files CSC.

## **3.2 Digital Message Communication Console (DMCC).**

### **3.2.1 Description.**

The DMCC (Figure 3.2.1-1) allows transmission, reception, storage of, and access to, pre-formatted and free text tactical messages between Ground Support, Tactical Operations Centers, Fire Support Elements, and manned Vehicle Simulators, via the SIMNET and DIS simulation networks. The DMCC uses graphical user interfaces to emulate vehicle crew station soldier machine interfaces. Up to eight X-terminals may be connected to the server workstation via a dedicated Ethernet local area networks

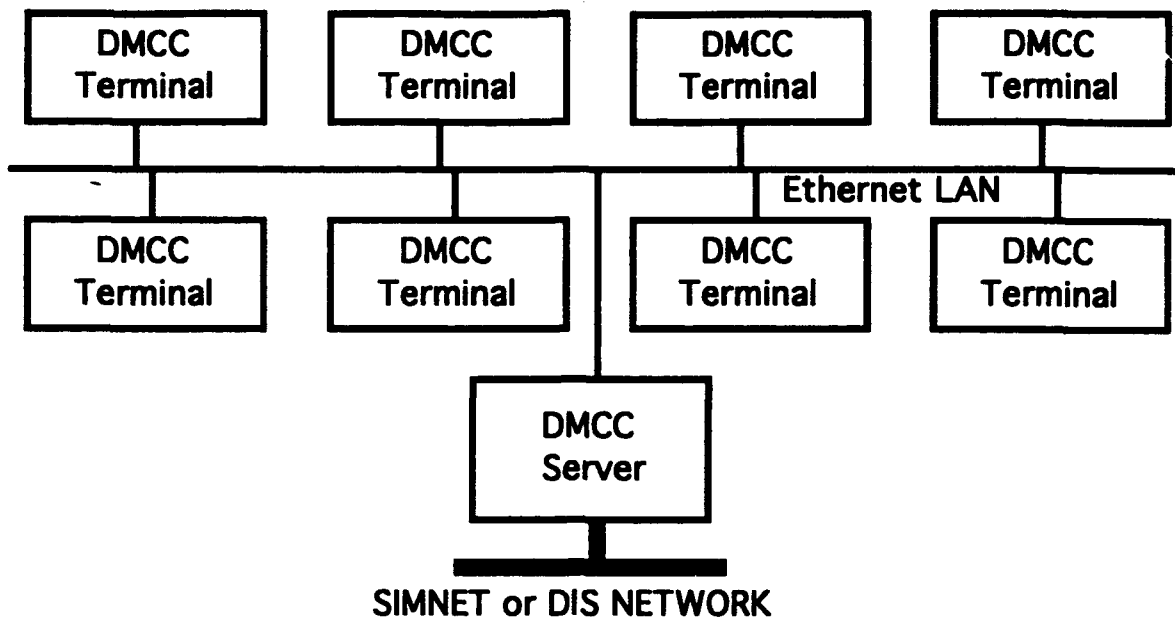

Figure 3.2.1-1. Digital Message Communication Console (DMCC) Diagram

### 3.2.2 Documentation.

- a. Software Maintenance Manual (SMM) for the DMCC (TR-93-003062).
- b. Cold Start Procedure (CSP) for the DMCC (TR-93-003047).
- c. Operations Manual (OPS) for the DMCC (TR-93-003054A).
- d. Version Description Document (VDD) for the DMCC (TR-93-003046).
- e. Software Design Document (SDD) for the DMCC SCSI (TR-93-003036).

### 3.2.3 Software.

- a. BDS-D DMCC 1.0.0 Source and Runtime Files.
- b. X11 Release 5 Windowing System.
- c. Motif Version 1.1.3.
- d. SUNOS 4.1.1.

### 3.2.4 Computer Software Configuration Item (CSCI) Breakdown.

- a. dms Computer Software Component (CSC).
- b. build pdu CSC.
- c. ipc CSC.

- d. ethernet CSC.
- e. client CSC.

### **3.3 M1 / M2 / STEALTH Simulators.**

#### **3.3.1 Description.**

A vehicle simulator is composed of one or more crewstations. Each crewstation provides the subset of controls and indicators that would be available to that specific crew member on the actual vehicle. A critical element of each crewstation is the out-the-window view, or vision block associated with the station. These provide the crew member with a three dimensional graphical representation of the terrain and objects in the environment external to the vehicle. The purpose of the vehicle simulation software (Figure 3.3.1-1) is to maintain the vehicle specific model, respond to crew inputs, update crewstation outputs, and communicate with the network. The vehicle-specific model includes the mathematical model of the drivetrain, power plant, suspension, weapons systems, and other internal systems necessary to compose the vehicle entity. These systems that are modeled have their corresponding operator interfaces in the crewstations. The crewstation outputs include the local sound system and the updates to the Computer Image Generator (CIG), which presents the three dimensional image in the vision blocks. Though it may be composed of several individual crewstations, the vehicle simulation represents a single entity on the network, and interacts with other network entities via the network interface.

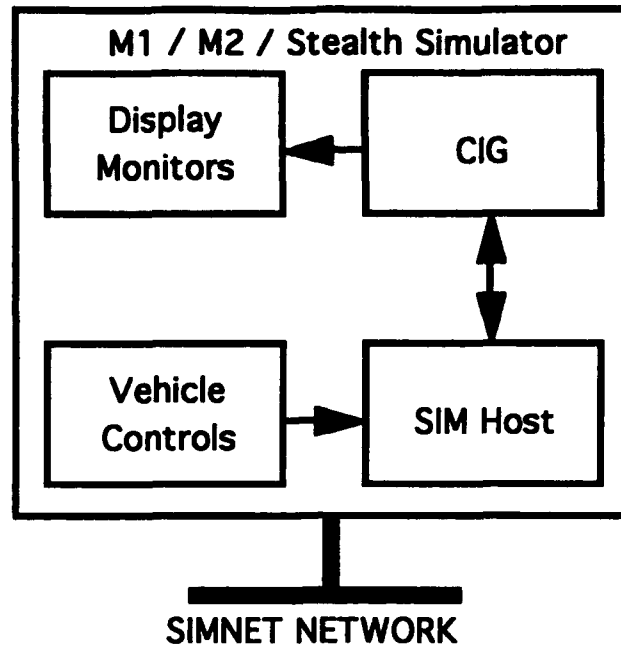

Figure 3.3.1-1. M1 / M2 / Stealth Simulator Diagram

### 3.3.2 Documentation.

- a. Software Design Document for the Vehicle Simulation CSCI (Volumes 1 through 4, June 1991).
- b. Software Design Document for the CIG Host CSCI (June 1991).
- c. Software Design Document for the GT Real-Time Software Host CSCI (Volumes 1 and 2, June 1991).
- d. Version Description Document (VDD) for the GT-M1 (TR-92-003032).
- e. Cold Start Procedure (CSP) for the GT-M1 (TR-92-003033A).
- f. Version Description Document (VDD) for the M1/XROD (TR-93-003030).
- g. Cold Start Procedure (CSP) for the M1/XROD (TR-92-003031A).
- h. Version Description Document (VDD) for the Masscomp-M1 (TR-93-003066).
- i. Cold Start Procedure (CSP) for the Masscomp-M1 (TR-93-003072).
- j. Version Description Document (VDD) for the VIDS-GT-M1 (Draft).
- k. Cold Start Procedure (CSP) for the VIDS-GT-M1 (Draft).
- l. Operation Manual (OPS) for the VIDS-GT-M1 (Draft).

### **3.3.3 Software.**

- a. GT rtt 5.7 Visual System Software.
- b. GTOS 4.7 Operating System.
- c. GT 6.6.1 M1 Source, Application, and Runtime Files.
- d. GT 6.6.1 M2 Source, Application, and Runtime Files.
- e. GT 6.6.1 Stealth Source, Application, and Runtime Files.
- f. Terrain Databases.
- g. BDS-D M1 1.0.0 Source, Application, and Runtime Files.
- h. Masscomp Real Time UNIX RTU4.0A.
- i. BDS-D M1/XROD 1.0.0 Source, Application, and Runtime Files.
- j. BDS-D VIDS Source, Application, and Runtime Files.
- k. DOS 5.0.

### **3.3.4 Computer Software Configuration Item (CSCI) Breakdown.**

- a. Device Interfaces Computer Software Component (CSC).
- b. M1 Vehicle Simulation Functions CSC.
- c. M2 Vehicle Simulation Functions CSC.
- d. Stealth Vehicle Simulation Functions CSC.
- e. Vehicle Libraries CSC.
- f. Simulation Support Utilities CSC.

## **3.4 Combat Vehicle Command and Control (CVCC).**

### **3.4.1 Description.**

The CVCC (Figure 3.4.1-1) is a M1 tank simulator which has been modified to test several future tank design concepts and features. The CVCC incorporates a position navigation system, a commander's independent thermal viewer, a thermal sight channel for the gunner, and an updated version of the Inter-Vehicular Information System (IVIS).

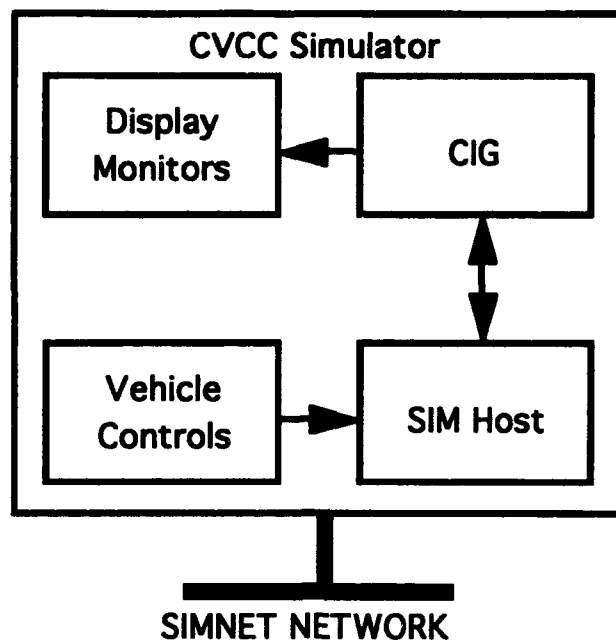

Figure 3.4.1-1. Combat Vehicle Command and Control (CVCC) Diagram

### 3.4.2 Documentation.

- a. Cold Start Procedure (CSP) for the CVCC (TR-93-003211).
- b. Version Description Document (VDD) for the CVCC (TR-93-00312).
- c. SIMNET Combat Vehicle Command and Control (CVC2) System (December 1990).
- d. SIMNET CVCC IVIS Utilities User Manual (July 1991).

### 3.4.3 Software.

- a. SUNOS Version 4.1.2.
- b. SUN OpenWindows 3.0.
- c. ICS Motif Version 1.1.3.
- d. GNU gdbm Version 1.5.
- e. BDS-D CVCC Source, Applications, and Runtime Files.
- f. Terrain Databases.

### 3.5 Protocol Translator (PT).

#### 3.5.1 Description.

The Protocol Translator (PT) (Figure 3.5.1-1) supports interoperability between SIMNET and DIS 1.0 simulation exercises within the constraints of translated PDUs. The PT consists of two parallel processes, the DIS-to-SIM translator and the SIM-to-DIS translator. The DIS-to-SIM translator receives DIS 1.0 UDP datagrams from the designated DIS ethernet interface and sends the translated datagrams in SIMNET format to the SIMNET network through the designated SIMNET ethernet interface. The SIM-to-DIS translator receives SIMNET PDUs from the designated SIMNET ethernet interface and sends the translated PDUs in DIS 1.0 format to the DIS network through the designated UDP port.

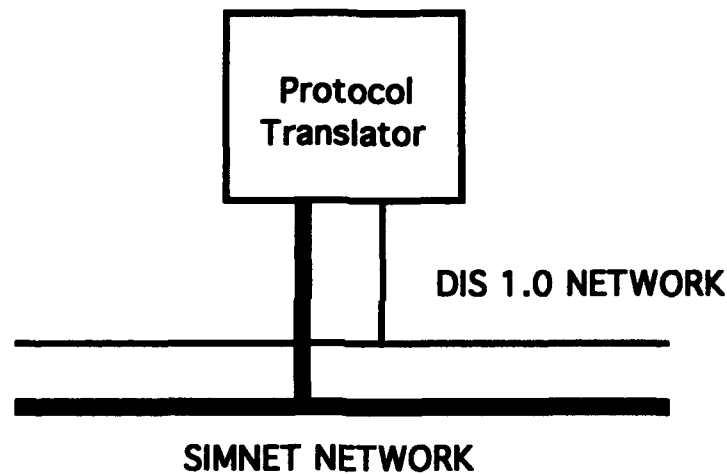

Figure 3.5.1-1. Protocol Translator (PT) Diagram

#### 3.5.2 Documentation.

- a. Software Maintenance Manual (SMM) for the PT (TR-93-003064).
- b. Interface Requirements Specification (IRS) for the PT (TR-93-003065).
- c. Version Description Document (VDD) for the PT (TR-93-003213).
- d. Cold Start Procedure (CSP) for the PT (TR-93-003214).
- e. Software Design Document (SDD) for the PT (TR-93-003071).
- f. Software Requirements Specification (SRS) for the PT (June 1992).

### 3.5.3 Software.

- a. BDS-D PT 2.0.0 Source and Runtime Files.
- b. SUNOS 4.1.1.
- c. Openwindows 3.0.
- d. Gcc C Compiler Version 1.4 (or higher).

### 3.5.4 Computer Software Configuration Item (CSCI) Breakdown.

- a. SIMNET Network Interface Process Computer Software Component (CSC).
- b. DIS Network Interface Process CSC.
- c. SIMNET to DIS Format Translation Process CSC.
- d. DIS to SIMNET Format Translation Process CSC.
- e. Dead Reckoning CSC.

## 3.6 Plan View Display (PVD).

### 3.6.1 Description.

The PVD's (Figure 3.6.1-1) function is to provide a map-based "God's eye view" of one or more distributed simulation exercises. The PVD can display the entire terrain database or selected regions via menu selection. Vehicles in the distributed simulation are represented by small icons that show the vehicle location and hull/turret orientation. Intervisibility between vehicles on the terrain can be displayed. The PVD can remotely control both the data logger and the stealth vehicle.

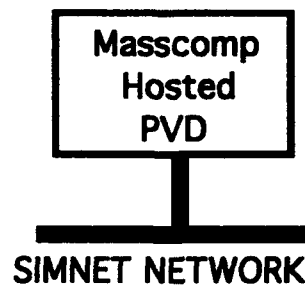

Figure 3.6.1-1. Plan View Display (PVD) Diagram

### **3.6.2 Documentation.**

- a. Cold Start Procedure (CSP) for the PVD (TR-93-003077).
- b. Version Description Document (VDD) for the PVD (TR-93-003076).
- c. Software Design Document for the PVD CSCI (Volumes 1 and 2, June 1991).

### **3.6.3 Software.**

- a. PVD 1.0.0 Source and Runtime Files.
- b. Masscomp Real Time UNIX (RTU) Version 4.0A.

### **3.6.4 Computer Software Configuration Item (CSCI) Breakdown.**

- a. Menu Handling Computer Software Component (CSC).
- b. Icons CSC.
- c. Map Handling CSC.
- d. PVD-Level Processing CSC.
- e. Utilities CSC.
- f. Network Processing CSC.
- g. Graphics CSC.
- h. Overlays CSC.
- i. Popup Windows CSC.
- j. Tools CSC.
- k. Remote Devices Interfaces CSC.

## **3.7 Semi-Automated Forces (SAF).**

### **3.7.1 Description.**

The Semi-Automated Forces (SAF) systems (Figure 3.7.1-1) provide a means of incorporating intelligent, realistic participants not requiring a vehicle simulation into a network battle exercise. It is typically partitioned across several processing platforms, the minimal configuration usually being a vehicle simulation processor and a Graphical User Interface (GUI) processor. There are currently three SAF systems available: the SIMNET SAF system, the Order of Battle Generator (OBG)/SAF system, and the Modular SAF (ModSAF) system.

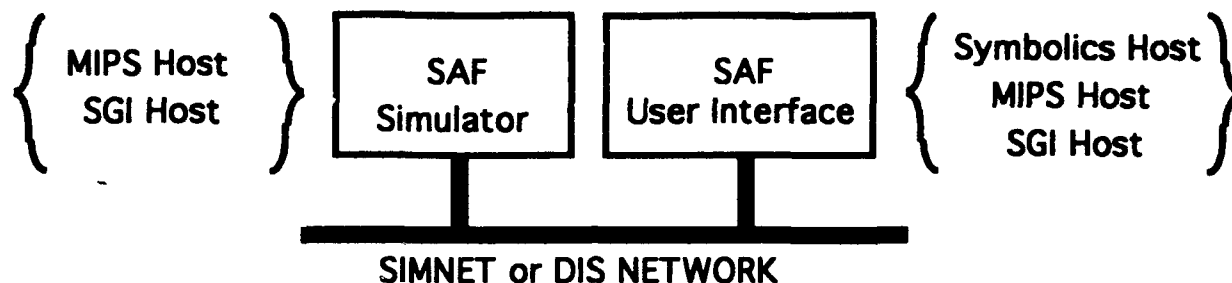

Figure 3.7.1-1. Semi-Automated Forces (SAF) Diagram

### 3.7.2 Documentation.

#### 3.7.2.1 SIMNET SAF.

- a. Software Design Document for the SAF Workstation CSCI (Volumes 1 and 2, June 1991).
- b. Software Design Document for the SAF Parameter Editor CSCI (June 1991).
- c. Software Design Document for the SAF Simulation Host CSCI (Volumes 1 and 2, June 1991).

#### 3.7.2.2 OBG/SAF.

- a. The OBG/SAF Interface Version 4.3.3 User Guide.
- b. Notes for SAF Version 4.3.3 Release.

#### 3.7.2.3 ModSAF.

- a. ModSAF User Manual Version 1.0.
- b. ModAF 1.0 Release Notes.

### 3.7.3 Software.

#### 3.7.3.1 SIMNET SAF.

- a. Geneva 7.2 OS.
- b. SIMNET SAF Version 3.11.2 Source and Runtime Files.
- c. Terrain Database.

### **3.7.3.2 OBG/SAF.**

- a. OBG/SAF 4.3.3 Source and Runtime Files.
- b. Terrain Database.

### **3.7.3.3 ModSAF.**

- a. ModSAF Version 1.0 Source and Runtime Files.
- b. Terrain Database.

## **3.7.4 Computer Software Configuration Item (CSCI) Breakdown.**

### **3.7.4.1 Graphical User Interface (GUI).**

- a. User Process CSC.
- b. Commander CSC.
- c. Battlemaster CSC.
- d. Map Display CSC.
- e. World State CSC.
- f. SAF Command Protocol Interface CSC.
- g. Global CSC.
- h. Utilities CSC.
- i. Compilation and Installation CSC.

### **3.7.4.2 Parameter Editor.**

- a. Model Editor CSC.
- b. Weapons Systems Editor CSC.
- c. Formations Editor CSC.

### **3.7.4.3 SAF Simulation.**

- a. Initialization CSC.
- b. Scheduler CSC.
- c. Network Interface CSC.
- d. SAF Command Interface CSC.
- e. Parser Interface CSC.
- f. Local Vehicles CSC.

- g. Remote Vehicles CSC.
- h. Remote Vehicles CSC.
- i. Units CSC.
- j. SAF Objects CSC.
- k. OPORDERS CSC.
- l. Create CSC.
- m. Terrain CSC.
- n. Global CSC.
- o. Utilities CSC.
- p. Support CSC.

### **3.8 Rotary Wing Aircraft (RWA) Simulator.**

#### **3.8.1 Description.**

The Rotary Wing Aircraft (RWA) (Figure 3.8.1-1) simulates a manned flight vehicle and associated weapons systems for conducting simulated missions within a controlled database and tactical environment. The RWA operates on the same principles as a ground vehicle simulator. It contains a CIG for generating three-dimensional "out-of-the-cockpit" imagery to be displayed using either monitors or projectors. It provides the appropriate controls and indicators for each of the flight crew. A simulation host within the simulator maintains a flight model of the RWA and interacts with the crewstation control systems and CIG.

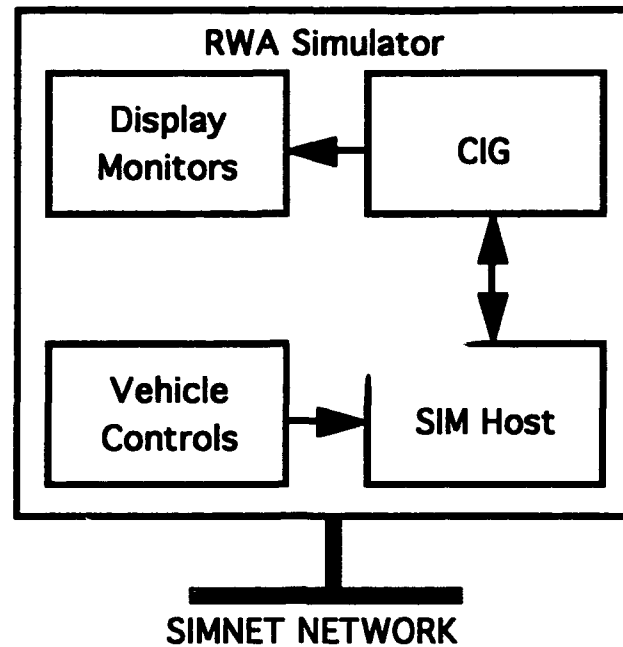

Figure 3.8.1-1. Rotary Wing Aircraft (RWA) Diagram

### 3.8.2 Documentation.

- a. Cold Start Procedure (CSP) for the RWA/Airnet (TR-93-003028A).
- b. Version Description Document (VDD) for the RWA/Airnet (TR-93-003066).

### 3.8.3 Software.

- a. GT rtt 5.7 Visual System Software.
- b. GTOS 4.7 Operating System.
- c. BDS-D RWA 1.0.0 Source, Application, and Runtime Files.

## 3.9 Computer Image Generator (CIG).

### 3.9.1 Description.

A Vehicle Simulator consists of a CIG (Figure 3.9.1-1), a simulation host, one or more display monitors, a user, and the user's control mechanisms. Each simulator simulates the actions of one combat vehicle in real time. The CIG controls the images in the simulation viewports (displays), and houses the database that describes the simulation terrain. The CIG can contain

one or two 9U graphics processor subsystems, also called backends. A backend can be either of the following:

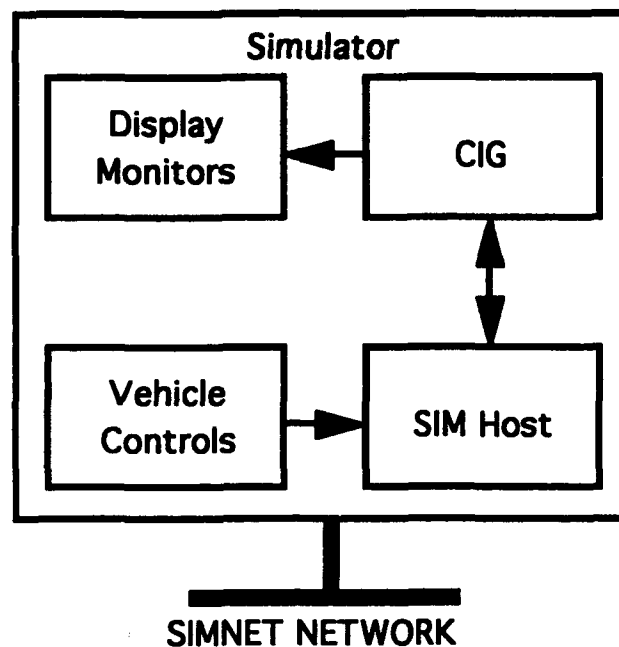

Figure 3.9.1-1. Computer Image Generator (CIG) Diagram

- a. A T backend generates up to eight low-resolution (320 by 200 pixels) views. These views are used in the M1 and M2 Simulators.
- b. A TX backend generates one high-resolution (640 by 480 pixels) view or two low-resolution (320 by 240 pixels) views. These views are used in the Stealth Simulators.

The GT101 is equivalent to the earlier 120T CIG. The GT110 is equivalent to the earlier 120TX CIG.

### 3.9.2 Documentation.

- a. Software Design Document for the CIG Host CSCI (June 1991).
- b. Software Design Document for the GT Real Time Software Host CSCI (June 1991).

### 3.9.3 Software.

- a. GT rt 5.5.
- b. GTOS 4.5 (used on CVCC simulator at Fort Knox).

- c. GTOS 4.7.
- d. GT 6.6.1 Source and Runtime Files.
- e. GT 6.6.1 Stealth Application.
- f. GT 6.6.1 M1 Source Files and Application.
- g. GT 6.6.1 M2 Source Files and Application.
- h. GT 6.6.1 DI Source Files and Application.
- i. Terrain Database.

### **3.9.4 Computer Software Configuration Item (CSCI) Breakdown.**

- a. Task Initialization CSC.
- b. CIG Host Mainline CSC.
- c. Database Management CSC.
- d. Database Feedback CSC.
- e. Ballistics Processing CSC.
- f. User's Interface CSC.
- g. Stand-Alone Message Interface CSC.
- h. Force Processor Task CSC.

### **3.10 Vehicle Integrated Defense System (VIDS).**

#### **3.10.1 Description.**

The VIDS-equipped M1 Tank Simulator (Figure 3.10.1-1) exists to support a series of survivability experiments. The nature of the experiments requires that the VIDS simulation be parameter-driven. The VIDS parameters not only define available sensors and countermeasures, but also define their respective sensitivities and response times. The VIDS M1 simulator and its associated PC communicate with each other over the SIMNET using a custom protocol. For the present, eight sensors and nine countermeasures are simulated. The sensors simulated are the Laser Warning Receiver (LWR), Missile Warning System (MWS), Future Armored System Radar (FASR), Seismic Mine Sensor, Non-Imaging System (NIS), Tank Radar Warning Receiver (TRWR), Muzzle Flash Detector (MFD), and a Nuclear Chemical Sensor (NCS). The countermeasures simulated are the Multi-Salvo Smoke Grenade Launcher/Rapid Obscuration System (ROS), Missile Countermeasure Device (MCD), Combat Protection System (CPS), Laser Countermeasure Device (LCMD), Vehicle Magnetic Signature Duplication (VEMASID), Nuclear Biological Chemical Overpressure (NBCOP), Advanced Threat Radar Jammer (ATRJ), Threat Countermeasure System (TCS), and Chaff/Flares.

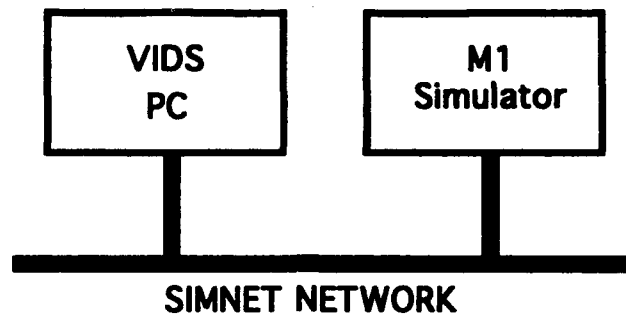

Figure 3.10.1-1. Vehicle Integrated Defense System (VIDS) Diagram

### 3.10.2 Documentation.

- a. Software Design Document for the Vehicle Simulation CSCI (Volumes 1 through 4, June 1991).
- b. Software Design Document for the CIG Host CSCI (June 1991).
- c. Software Design Document for the GT Real-Time Software Host CSCI (Volumes 1 and 2, June 1991).
- d. Version Description Document (VDD) for the GT-M1 (TR-92-003032).
- e. Cold Start Procedure (CSP) for the GT-M1 (TR-92-003033A).
- f. Version Description Document (VDD) for the M1/XROD (TR-93-003030).
- g. Cold Start Procedure (CSP) for the M1/XROD (TR-92-003031A).
- h. Version Description Document (VDD) for the Masscomp-M1 (TR-93-003066).
- i. Cold Start Procedure (CSP) for the Masscomp-M1 (TR-93-003072).
- j. Version Description Document (VDD) for the VIDS-GT-M1 (Draft).
- k. Cold Start Procedure (CSP) for the VIDS-GT-M1 (Draft).
- l. Operation Manual (OPS) for the VIDS-GT-M1 (Draft).

### 3.10.3 Software.

- a. GT rtt 5.7 Visual System Software.
- b. GTOS 4.7 Operating System.
- c. GT 6.6.1 M1 Source Files and Application.
- d. Terrain Databases.
- e. BDS-D M1 1.0.0 Source, Application, and Runtime Files.
- f. Masscomp Real Time UNIX RTU4.0A.
- g. BDS-D M1/XROD 1.0.0 Source, Application, and Run. .es.

- h. BDS-D VIDS Application.
- i. DOS 5.0.

### 3.10.4 Computer Software Configuration Item (CSCI) Breakdown.

- a. VIDS- GT CSC.
- b. VIDS-PC CSC.

### 3.11 Masscomp Hosted Management Command and Control (MCC).

#### 3.11.1 Description.

The MCC System (Figure 3.11.1-1) is used in setting up simulations and simulating elements of the battlefield environment. It tracks the condition of the various manned simulators for which it is responsible, as well as vehicles that it generates for service and repair. The MCC also handles various aspects of minelaying and monitors the availability of fuel and ammunition.

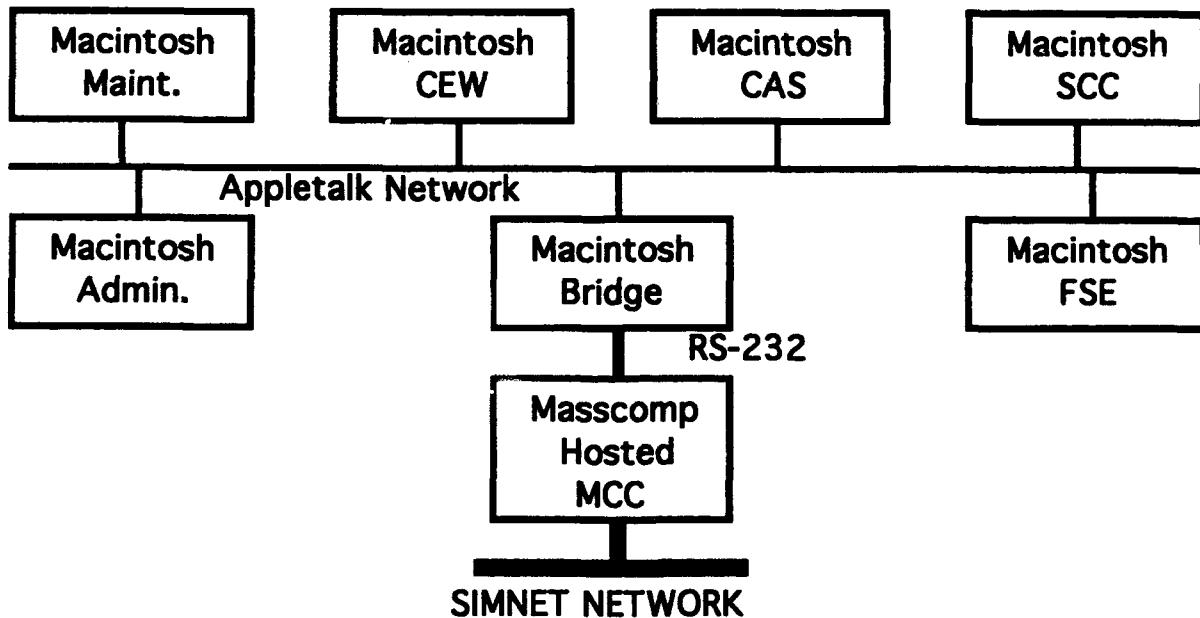

Figure 3.11.1-1. Masscomp Hosted Management Command and Control (MCC) Diagram

#### 3.11.2 Documentation.

- a. Software Maintenance Manual (SMM) for Masscomp hosted MCC (TR-93-003063A).

- f. Cold Start Procedure (CSP) for Masscomp hosted MCC (TR-93-003043).
- c. Operations Manual (OPS) for Masscomp hosted MCC (TR-93-003055B).
- d. Version Description Document (VDD) for Masscomp hosted MCC (TR-93-003042).
- e. Software Design Document for Masscomp hosted MCC (Volumes 1 and 2, June 1991).

### **3.11.3 Software.**

- a. BDS-D MCC/Masscomp Host 1.0.0 Source and Runtime Files.
- b. Masscomp Real Time UNIX (RTU) Version 4.0A.

### **3.11.4 Computer Software Configuration Item (CSCI) Breakdown.**

- a. Mother Process CSC.
- b. SCC Process CSC.
- c. Place Process CSC.
- d. Admin. Process CSC.
- e. Maint. Process CSC.
- f. FSE Process CSC.
- g. CAS Process CSC.
- h. CEW Process CSC.
- i. Terminal Process CSC.
- j. Masscomp Communications Software CSC.
- k. Bridge Process CSC.
- l. Appletalk Software CSC.
- m. SCC Console CSC.
- n. Place Console CSC.
- o. Admin. Console CSC.
- p. Maint. Console CSC.
- q. FSE Console CSC.
- r. CAS Console CSC.
- s. CEW Console CSC.
- t. Network Communications Libraries CSC.
- u. MCC Libraries CSC.
- v. Macintosh Libraries CSC.

### 3.12 MIPS Hosted Management Command and Control (MCC).

#### 3.12.1 Description.

The MCC System (Figure 3.12.1-1) is used in setting up simulations and simulating elements of the battlefield environment. It tracks the condition of the various manned simulators for which it is responsible, as well as vehicles that it generates for service and repair. The MCC also handles various aspects of mine laying and monitors the availability of fuel and ammunition. The MIPS computer has greater computational power than the original MCC Masscomp host. It maximizes the use of the existing SAF code and allows the MCC vehicles to be both visible and vulnerable at all times.

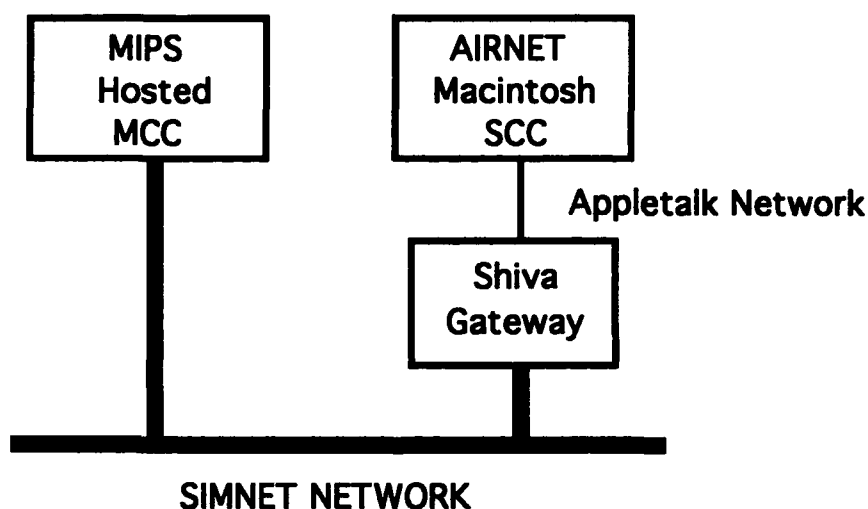

Figure 3.12.1-1. MIPS Hosted Management Command and Control (MCC) Diagram

#### 3.12.2 Documentation.

- a. Software Maintenance Manual (SMM) for the MIPS MCC (TR-93-003063A).
- b. Operations Manual (OPS) for the MIPS MCC (TR-93-003055B).
- c. Version Description Document (VDD) for the MIPS MCC (TR-92-003037).

#### 3.12.3 Software.

- a. MacPlus OS Release 6.0.3.
- b. MIPS RISC OS 4.5.1.
- c. CAP 6.0 KIP (Kinetics IP Appletalk Daemon).

- d. SIMNET Device Driver
- e. Shiva FastPath Version 4.0 (or higher).

#### **3.12.4 Computer Software Configuration Item (CSCI) Breakdown.**

- a. Mother Process Computer Software Component (CSC).
- b. SCC Process CSC.
- c. Place Process CSC.
- d. Terminal Process CSC.
- e. MIPS Communications Software CSC.
- f. Appletalk Software CSC.
- g. SCC Console CSC.
- h. Network Communications Libraries CSC.
- i. MCC Libraries CSC.
- j. Macintosh Libraries CSC.

#### **3.13 Network Protocols.**

The BDS-D network is in the process of migrating from SIMNET protocols to DIS protocols. Currently all BDS-D sites support SIMNET only. The SIMNET protocols are described in the SIMNET Network and Protocols<sup>15</sup>.

The next generation of Distributed Interactive Simulation (DIS) protocols is being developed by the Workshops on the Interoperability of Defense Simulations. Workshops are held biennially and have led to the formal adoption in March 1993 of the *Standard for Information Technology - Protocols for Distributed Interactive Simulation Applications* [IEEE, 1993]<sup>16</sup> as an Institute of Electrical and Electronics Engineers (IEEE) standard. Development of the standard has continued; and the latest description of the DIS protocols can be found in the third draft of DIS 2.0, which was released in May of 1993<sup>17</sup>.

The SIMNET baseline system is implemented using a family of related protocols. These protocols include a simulation protocol, a data collection protocol, and an association protocol. The simulation protocol is used to introduce simulated elements into an exercise, remove them from an exercise, and convey information about the simulated world for use by simulators. The data collection protocol is used to record information about an exercise. The association protocol provides communications services required for distributed simulation and supports both the simulation and data collection protocols.

There are 19 SIMNET Simulation Protocol PDUs:

- a. Activate Request.
- b. Activate Response.
- c. Deactivate Request.
- d. Deactivate Response.
- e. Vehicle Appearance.
- f. Radiate.
- g. Fire.
- h. Impact.
- i. Indirect Fire.
- j. Collision.
- k. Service Request.
- l. Resupply Offer.
- m. Resupply Received.
- n. Resupply Cancel.
- o. Repair Request.
- p. Repair Response.
- q. Marker.
- r. Breached Lane.
- s. MineField.

There are four kinds of SIMNET Association PDUs:

- a. datagram.
- b. request.
- c. response.
- d. padding.

There are eight SIMNET Data Collection PDUs:

- a. Exercise Status.
- b. Simulation Status.
- c. Vehicle Status.
- d. Status Query.
- e. Status Response.
- f. Status Change.
- g. Laser Range.
- h. Event Flag.

The network requirements for running SIMNET protocol are summarized below:

- a. The network must support connectionless data transfer (i.e., datagram service).
- b. A datagram must be able to convey at least 256 octets of information.
- c. The network must provide for either broadcasting of datagrams or multicasting.
- d. The network should have a low rate of non-delivery.
- e. The network should maintain datagram integrity.

In addition, there are certain performance parameters which must be met with respect to throughput and delay.

#### **4 ADST SYSTEM ENGINEERING.**

This section describes the mechanisms, tools and facilities employed by the ADST Program staff to provide for tracking of the BDS-D System Definition status. Both current and future capabilities are included, as appropriate, to afford the reader a better understanding of the data presented in this document.

A major focus of the systems engineering effort is to monitor the wide variety of efforts under ADST cognizance for an orderly and rapid progression towards satisfying the BDS-D Program Plan exit criteria. In particular, the systems engineering function examines projects for deficiencies and inconsistencies with respect to fundamental guiding principles (such as the DIS architecture), as well as attempts to minimize redundancies between D.O.s. In this way, there is assurance that every D.O. can capitalize on the advances made by other D.O.s. Figure 4-1 illustrates this systems engineering process and its relation to other activities.

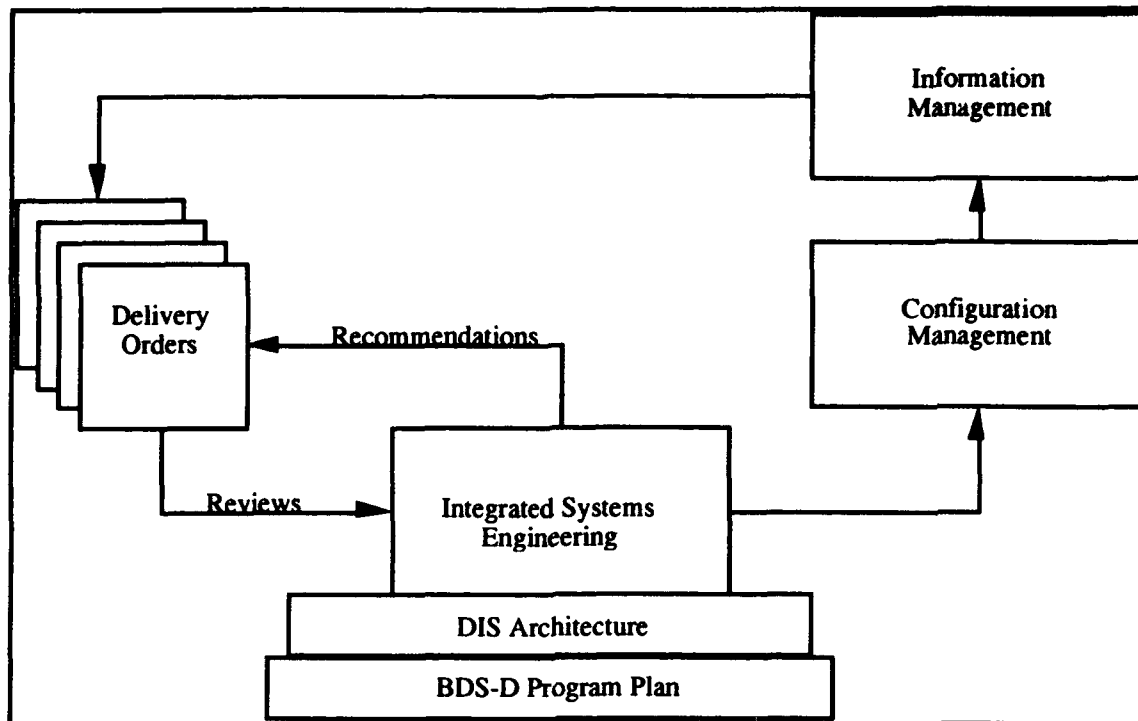

Figure 4-1. System Engineering Diagram

#### 4.1 Configuration Management.

Configuration Management (CM) is a set of processes which creates and maintains a high integrity database of the technical details of a system and establishes a set of procedures for the purpose of controlling modifications to that system. The CM of the BDS-D/DIS system has multiple dimensions, chief among which are hardware CM, software CM, virtual battlefield CM, and operational procedures CM. These dimensions cover all manual and automated procedures, machines, and information elements under the cognizance of the ADST program.

##### 4.1.1 Configuration Management Plan.

A Configuration Management Plan<sup>18</sup> has been developed which describes the organizations, baseline identification, configuration controls, interface management, traceability, status accounting, references company directives where appropriate, and configuration management audits. These audits are provided by the quality assurance organization, which writes a report once it has performed an audit.

#### **4.1.2 Hardware Configuration Management.**

Hardware CM is the management of all system hardware components, to include power distribution and site layout; subsystem electrical signal and power configuration; rack elevations; schematics; and hardware inventories. Currently, hardware CM is a local (site) responsibility. Current hardware inventories of ADST sites are available upon approved request from each site.

#### **4.1.3 Software Configuration Management.**

Software CM is regarded as a major subset of the overall Loral and ADST configuration management system. An established SCM team provides effective management, control, identification, audit and status accounting over the evolving ADST BDS-D/DIS configuration baselines of all software products, and their technical requirements, and conformance to these requirements. The software configuration consists of all documents produced during the software engineering definitions and development phases (i.e., executable code, source files, tests/results, Cold Start Procedures, and Version Description Documents). The software configuration is controlled in a concise process for each succeeding software engineering step.

##### **4.1.3.1 Software Baseline Identification.**

The ADST team approach to managing the software life cycle is based on establishing a product baseline. The Product Baseline (initially SIMNET Version 6.6.1) is used as the starting baseline for subsequent design development and/or D.O.s. Changes to the product baseline will be established to define a formal departure point for control of future revisions, or deliveries. In the event that a new simulator is developed, configuration identification will be established in the form of technical specifications for the system, the system segments, and each Configuration Items (CI/CSCI). Hence, Functional Configuration Identification (FCI) will be established against performance-oriented requirements for the segment design and performance.

The ADST project involves the development and maintenance of many complex software components which execute on several hardware platforms. The project software development is not for the purpose of achieving one delivery; rather, it is for the purpose of achieving multiple releases with potential increasing capabilities for a particular configuration.

The elements below comprise the engineering groundwork required to support a D.O. Software release process. The elements required for a D.O. package may vary based on requested sponsorship and will be funded with each D.O. The release kit, including the code, is for general release unless specified by the customer.

- a. Delivery of a Version Description Document (VDD)
- b. Provide required executable code, object code, data files, tables and parameter files to bring up a system. Include a read.me file with appropriate header information to identify tapes for loading software.
- c. Cold Start Procedures (CSP).
- d. Installation procedures.
- e. Build and distribution instructions.
- f. Identification of known problems.
- g. Regression test results.
- h. English narrative synopsis of functionality of the released system.
- i. List of documents applicable to the configuration.
- j. Release Notes, if appropriate, depicting notes/differences/compatibility since the last release.
- k. Provide tools to support any necessary on-site regression testing.
- l. Provide POC (name/phone number) for each release.
- m. User Guides (as funded by a D.O.).

The current status of the SWCCP is summarized in Table 4.1.3.1-1.

Table 4.1.3.1-1. SWCCP Current Status

SWCCP Xref	Product Title	Asgd	Current Baseline	VDD	CSP	Notes
4	Configuration Management Plan	LADS-SJ	N/A	N/A	N/A	Completed / Accepted
	Common Software Study	LADS-CB	N/A	N/A	N/A	Completed / Accepted
	Software Maintenance Manual	TBD	N/A	N/A	N/A	On hold
5	Software Development Plan	LADS-SJ	N/A	N/A	N/A	To be worked in August
6	M1/GT Host SW Baseline	LADS-SJ	1.1.0 / 1-20-93	1.0.0 / 12-22-92	Due 7-21-93	Completed / Accepted
6	M1/Masscomp Host SW Baseline	LADS-SJ	1.0.0 / 2-26-93	1.0.0 / 4-20-93	4-20-93	Completed / Accepted
7	M2 Butterfly Host SW Baseline	LADS-CB	Need Status	Need Status	Need Status	Awaiting Status
8	NO&M SW Baseline	LADS-CB	Need Status	Need Status	Need Status	Awaiting Status
9	RWA SW Baseline	LADS-SJ	1.4.4 / 3-17-93	1.0.0 / 11-22-92	5-21-93 *	Completed / * Await Accept
10	Stealth Masscomp Host SW Baseline	LADS-OR	TBD	TBD	TBD	Transfer Orlando
10	Stealth GT Host SW Baseline	LADS-CB	Need Status	Need Status	Need Status	Awaiting Status
11	SAF (Symb/MIPS) SW Baseline	LADS-SJ	TBD	TBD	TBD	On Hold. Skalnotty Equip.
12	Dismounted Infantry SW Baseline	LADS-OR	TBD	TBD	TBD	Transfer Orlando
13	FWA SW Baseline	LADS-OR	TBD	TBD	TBD	Transfer Orlando
14	Data Logger SW Baseline	LADS-SJ	2.0.0 / 6-11-93	1.0.0 / 4-9-93	5-21-93 *	Completed / * Await Accept
16	CVCC/IVIS SW Baseline	LADS-SJ	TBD	TBD	TBD	On Hold
17	AirNet MCC/MIPS Host SW Baseline	LADS-SJ	2.0.0 / 3-10-93	1.0.0 / 12-22-92	Due 7-23-93	Partially Complete
	AirNet MCC/Mac Host SCC SW Baseline	LADS-SJ	1.0.0 / 3-23-93	1.0.0 / WIP	Due 7-23-93	Partially Complete
18	MCC/Masscomp Host SW Baseline	LADS-SJ	2.0.0 / 3-24-93	1.0.0 / 4-19-93 *	5-21-93 *	Completed / * Await Accept
	MCC/Mac Host Admin SW Baseline	LADS-SJ	2.0.0 / 5-11-93	2.0.0 / WIP	WIP	Partially Complete
	MCC/Mac Host CAS SW Baseline	LADS-SJ	1.1.0 / 2-10-93	1.1.0 / WIP	WIP	Partially Complete
	MCC/Mac Host CEC SW Baseline	LADS-SJ	1.1.0 / 2-10-93	1.1.0 / WIP	WIP	Partially Complete
	MCC/Mac Host FSE SW Baseline	LADS-SJ	1.1.0 / 2-10-93	1.1.0 / WIP	WIP	Partially Complete
	MCC/Mac Host Maint SW Baseline	LADS-SJ	2.0.0 / 5-11-93	2.0.0 / WIP	WIP	Partially Complete
	MCC/Mac Host Place SW Baseline	LADS-SJ	1.1.0 / 2-10-93	1.1.0 / WIP	WIP	Partially Complete
	MCC/Mac Host SCC SW Baseline	LADS-SJ	2.0.0 / 5-11-93	2.0.0 / WIP	WIP	Partially Complete
CCP Suplmt	PVD SW Baseline	LADS-SJ	1.1.0 / 4-7-93	1.0.0 / 4-9-93	5-21-93 *	Completed / * Await Accept

Table 4.1.3.1-1. SWCCP Current Status (Continued)

Non-SWCCP Products Under CM Control or In Work	Product Title	Asgd	Current Baseline	VDD	CSP	Notes
	CSRDF/Protocol Trans SW Baseline	LADS-SJ	1.3.3 / 5-28-93	1.0.0 / 4-28-93 *	4-28-93 *	Completed / * Await Accept
	ATAC II SW Baseline	LADS-SJ	1.1.0 / 4-7-93	1.1.0 / Due 8-6-93	Due 8-6-93	Working Documentation
	M1 CIG SW Baseline	N/A	N/A	N/A	N/A	Not to be worked
	M1/XROD SW Baseline	LADS-SJ	1.1.0 / 11-2-92	1.1.0 / 12-22-92	Due 7-21-93	Partially Complete
	VIDS-M1 SW Baseline	LADS-SJ	1.0.0 / 6-4-93	After Phase II	Phase II	Builds Completed
	VIDS-CCDP (PC Code) SW Baseline	LADS-SJ	1.0.0 / 6-4-93	After Phase II	Phase II	Builds Completed
	VIDS-MCC SW Baseline	LADS-SJ	1.0.0 / 3-24-93	After Phase II	Phase II	Builds Completed
	VIDS-Mac SCC SW Baseline	LADS-SJ	1.0.0 / 3-22-93	After Phase II	Phase II	Builds Completed
	VIDS-SAFOR SW Baseline	LADS-SJ	After Phase II	After Phase II	Phase II	
	VIDS- SMS SW Baseline	LADS-SJ	WIP	N/A	N/A	WIP
	NLOS SW Baseline	LADS-SJ	N/A	N/A	N/A	Await release to CM 9-93

#### 4.1.3.2 Software Change Control.

The control process for each product or D.O. under development adheres to a set of activities that is accomplished in a particular order to conform to the building block approach of the Software Problem/Change Report (SP/CR) validation and verification. The CM tools and directory structure provide CM with the ability to uniquely identify and build a D.O. product baseline. In this process, there are related phases that provide the ability to incrementally build on a foundation of a tested, controlled, and validated baseline. There is one CM library area that is managed and maintained by the CM team. This domain is referred to as the Software Support Library (SSL). An identical structure is created from the CM area for developers to perform upgrades. Here, developers code and build their changes. After successful development / unit test on the target machine, the change is turned over to CM for control and incorporation into the CM baseline via an approved SP/CR. Figure 4.1.3.2-1 provides a graphical view of the CM SSL structure.

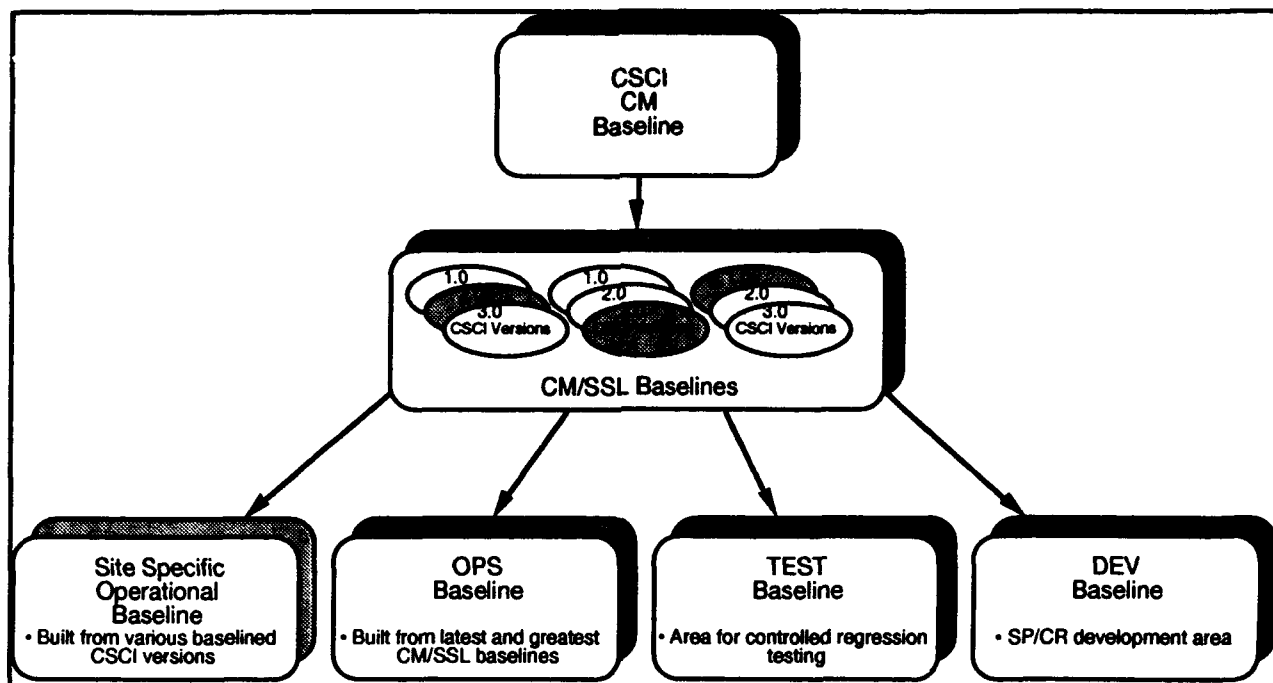

Figure 4.1.3.2-1. Software Support Library Structure

The CM/SSL baseline structure is a controlled environment, which provides protection from unauthorized software changes. It contains modules which have been identified by software engineers for control and are managed by the Configuration Management team under the Revision Control System (RCS) or other CM software packages as applicable. These modules have been built (compiled and linked) to produce an application build load or D.O. Each build load is flagged via RCS with a revision number associated with the particular D.O. Changes to software modules will be identified by an SP/CR number in the header / prologue block of the source. The SP/CR will remain open until the change has been validated through regression testing in a closely monitored integration environment.

The development, test, and operational software baselines are maintained in directory structures on the target machines under the SSL that are closely monitored by CM. The CM Baseline directories contain a snapshot of the controlled baselines, which can be used to recreate a given environment. The Operational Baseline directory contains software which has been derived from some baseline, upgraded, tested, controlled, and labeled "operational." This directory and all subdirectories are under CM control by use of operating system protections. The Test Baseline directory contains a CM-built baseline which is not yet operational. Formal testing of software "captured" from developers is performed in this area. When this testing process has

determined that the software is working properly, it is moved into the Operational baseline directory by CM.

The Development Baseline area is where build loads are downloaded and distributed to the designated development configurations in the Software Development Facility (SDF) for SP/CR incorporation and further development and unit testing.

A CM library hierarchy has been established and includes separate RCS libraries for the specific baselines. Included in each baseline are source code, test plans, and documentation. This library hierarchy mirrors each vehicle and simulation subsystem development directory structure, thus facilitating the transfer of data while maintaining consistency of identification and design. Figure 4.1.3.2-2 provides a sample of the high level overview of the BDS-D SSL directory structure. Detailed module trees for each configuration can be obtained from the CM organization. In addition, each configuration Version Description Document contains a listing of the files and hierarchy structure.

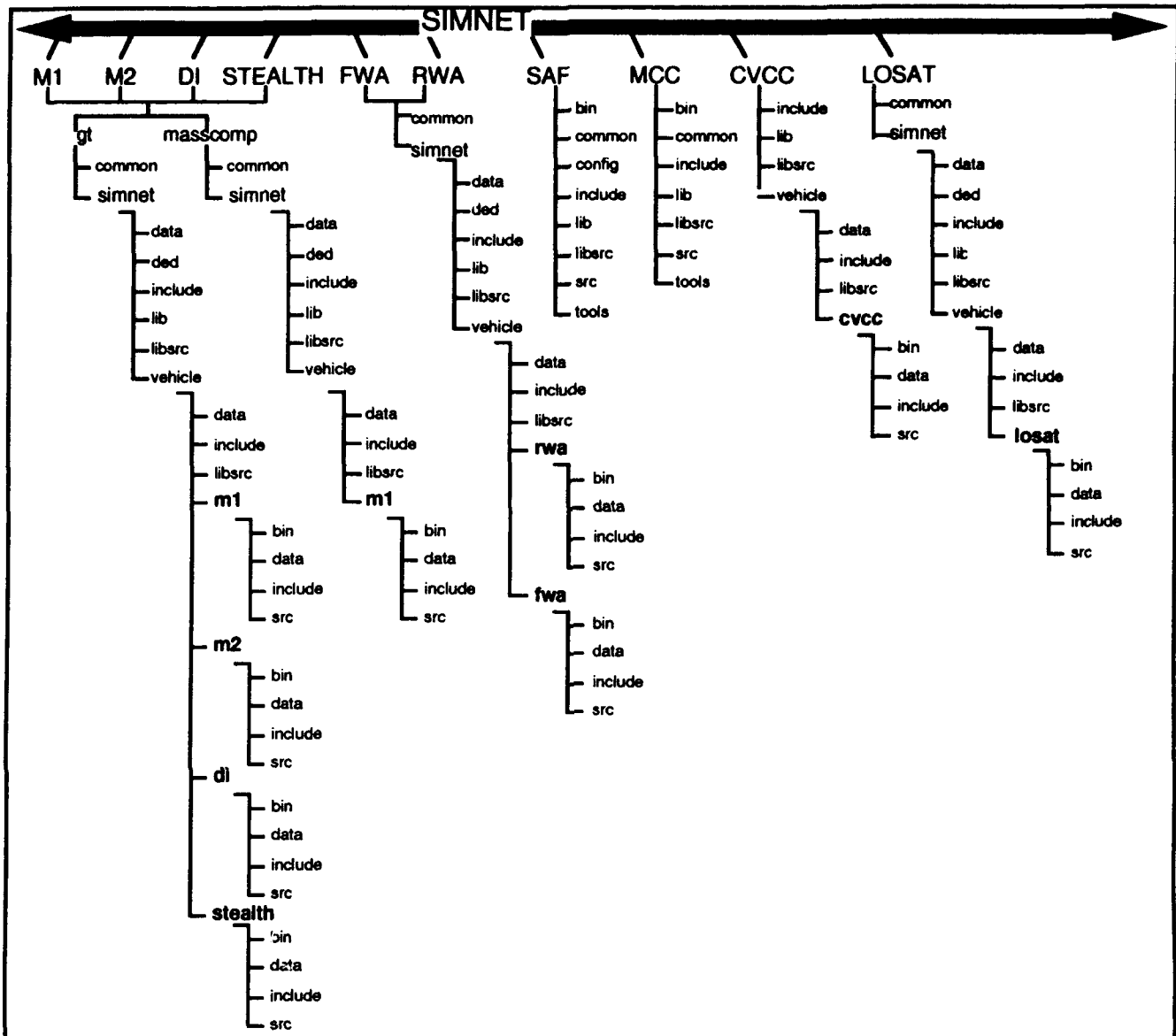

Figure 4.1.3.2-2. CM SSL Baseline Hierarchy

#### 4.1.3.2.1 Software Configuration Control Process.

The primary reporting mechanism for changes to the BDS-D/D.O. system configurations is via the Software Problem/Change Report. The SP/CR is used by the sites and the Configuration Control Board (CCB) to resolve design and document issues to the CM controlled software baseline. The SP/CR provides the means for reporting errors in development, test, and operational software and/or hardware. An SP/CR is completed by any user or developer who discovers a system anomaly, or desires a modification in order to improve system operational

efficiency. The SP/CR provides a formal means for recording all software and hardware faults and modification requests. Each SP/CR will be submitted to the CCB or respective site representative/D.O. Manager for analysis. SP/CRs which are out of scope, such as beyond the normal schedule, scope of current activities, budget or enhancements/improvements, will be forwarded to the LORAL WDL Program office for resolution. An SP/CR status report, which serves as the agenda, is prepared and distributed by Configuration Management in a timely manner to support the functions of the Board. Since the CCB representatives may be located at various facilities, technical interfacing will be accomplished via the conference phone. Status on all of the above actions from the CCB will be provided to the ADST Program Office and the Delivery Order Managers.

#### **4.1.3.2.2 Operating Procedures.**

Maintenance of such a large baseline is particularly challenging when multiple sites, hardware configurations, software configurations, and development organizations are involved. This is further compounded by the fact that these sites are geographically scattered across the country. As a result, it is important to define the procedures by which the existing baseline, SIMNET Version 6.6.1, is distributed to the various users for installation on simulators, development efforts on delivery orders, and for use on other efforts not necessarily related to ADST. A series of software support operating procedures (SSOP) have been written that describe how various activities related to the baseline will be performed. These procedures are:

- a. SSOP 1 - SSOP Purpose/Procedure.
- b. SSOP 2 - Configuration Control Board (CCB) Charter.
- c. SSOP 3 - Problem Reporting Procedure.
- d. SSOP 4 - Integration and Test Procedure.
- e. SSOP 5 - Code Checkout/FTP Procedure.
- f. SSOP 6 - ADST SDF Lab Rules and Procedures.
- g. SSOP 7 - Configuration Management Turnover Procedure.
- h. SSOP 8 - RCS Header Comment Standards.
- i. SSOP 9 - Delivery Order Release Kit Procedure.
- j. SSOP 10 - CM/SDF Build Load Distribution Procedure.
- k. SSOP 11 - ADST SDF Lab Rules and Procedures.
- l. SSOP 12 - Revision Control System (RCS) Procedure.
- m. SSOP 13 - Change Control/Build Procedure Field Support.
- n. SSOP 14 - SP/CR Audit Trails.

- o. SSOP 15 - BDS-D Data Transfer.
- p. SSOP 16 - ADST Documentation Preparation.

#### **4.1.4 Virtual Battlefield CM.**

The CM of the virtual battlefield is the systematic tracking of the configuration of the objects which appear on the BDS-D virtual battlefield. To effect this CM, a process closely related to VV&A (see section 4.2.3) must take place, i.e., the establishment of a detailed database which contains the information necessary to describe, build, and validate battlefield objects on the simulation. Progress toward development of such a capability has been made in both the VV&A subtask and the database subtasks of the BD-D Architecture Study, in particular with the evolution of the database concept. Current virtual battlefield weapon systems and objects are described briefly in Section 4.2.2 of this document.

#### **4.1.5 Configuration Control Board (CB).**

The Loral San Jose DL Configuration Control Board (CB) is designated as the Central CB (i.e. single control point) for all changes to the established BDS-D software product baselines. In order to ensure consistency between the site development changes and the central software baseline, all CM-related operations require communication and coordination in cooperation between the San Jose CM staff, D.O. Managers, and site representatives. The sites will apprise the CB of any possible or proposed changes to the product baseline. The respective D.O. Manager and site representative will review and approve site-generated PS/Cs. Configuration reviews and the CB will ensure proper application of configuration control and establish the basis for status accounting. The CB will provide active program support and establish a team for coordinating, monitoring, and implementing change control. The CB will interact with the Loral Ireland Program Management Office, site representatives, and with the customer to adjudicate proposed changes to the baselines.

#### **4.1.6 Configuration Tracking.**

The CM organization is responsible for tracking the various versions of hardware and software comprising the SIGNET community. For instance, the Management Control Console (CM) may be the same hardware configuration at Fort Knox and Fort Rucker, but be running different software loads as a result of changes being implemented at one site in support of a delivery order. Not only will the CM organization track these changes, they will also be able to archive and retrieve a historical software release should the need arise. The process becomes

even more complex in cases where CM must maintain the build in use at the training sites, support multiple ongoing development efforts in the that change the hardware configuration, while supporting both on site and off site development.

The necessity for maintaining tractability to the parent configuration, both from a hardware and software point of view, requires adherence to the documented procedures described in the previous section.

Another dimension to the configuration tracking process is the requirement to identify the development system required to support the target system, as they are often different hardware suites. Not only must the development system configuration be identified, its location must also be tracked since development can take place at many different locations.

#### **4.1.7 Configuration Status Accounting.**

Configuration Status Accounting will be the means through which control and tracking of discrepancies and change requests affecting CI/CSCIs are reported to STRICOM and engineering managers concerned.

The Configuration Status Accounting contains a Configuration Identification List, D.O. Status Log, and Version Descriptions Documents. Whenever a status change occurs, the Configuration Identifications Database is updated to reflect its current status. Approved D.O.s to the product baseline developmental configurations are listed, thus providing a status accounting of D.O.s against each CSCI.

#### **4.1.8 Configuration Audits.**

Formal configuration audits and reviews for the ADST program are not a requirement of the SWCCP. However, informal technical reviews and technical audits will be part of the surveillance throughout the life cycle of the project.

In addition, a Software Quality Assurance (SQA) function is in place and is responsible for monitoring internal configuration management procedures that ensure compliance with the SWCCP and CMP. The SQA representative provides a continuing check on all software maintained for the ADST program. SQA coordinates and periodically audits the configuration maintenance activities to ensure consistency between the controlled documentation, software, and database elements comprising each D.O. configuration. SQA works with CM to ensure

that baseline, status accounting, library and change control procedures are being appropriately presented to the CCB. SQA will conduct a review of all products in conjunction with a major software baseline capture and/or release, in lieu of a PCA/FCA.

## 4.2 Topics and Activities.

### 4.2.1 System Architecture Definition.

A key function of the ADST systems engineering staff is the definition of an open architecture to support the BDS-D exit criteria. Such an architecture was first introduced in the Strawman Architecture document<sup>19</sup> and has continued to develop in the subsequent periods of performance of the ADST contract. The latest architectural information is contained in the following series of documents.

- a. System Design Specification for the Battlefield Distributed Simulation - Developmental (BDS-D) System Version 1.0.<sup>20</sup> This document defines the requirements for the various components that are to be developed for integration within the standards and guidelines established for Distributed Interactive Simulation (DIS) as applied to BDS-D Version 1.0. This document contains discussion of all major BDS-D architectural components (Table 4.2.1-1).

Table 4.2.1-1. BDS-D Architectural Components

DIS Basic Interface Package (BIP)
DIS Test Tools
DIS Cell Interface Unit (CIU)
DIS Cell Adapter Unit (CAU) for Virtual Cell
BDS-D Simworld Database
DIS Extensions Interface Package
DIS Session Manager
DIS MCC
DIS After Action Review (AAR) Station
DIS Plan View Display
DIS Visual Stealth
DIS Radio Stealth
DIS Data Logger
DIS Statistical Analysis Package
DIS Environmental Simulator
DIS Long Haul Network
DIS Security Unit
DIS Network Manager
DIS ModSAF Upgrade
DIS CAU for Constructive Cell
DIS CAU for Live Cell

- b. Distributed Interactive Simulation (DIS) Architecture Description Document.<sup>21</sup> This document is an update of the original Strawman Architecture document.
- c. System Design ICD for the BDS-D System Version 1.0.<sup>22</sup> This document is an interface requirements specification (IRS) and examines all external system interfaces that allow other simulation systems to interact with the components of the BDS-D Version 1.0 System.
- d. BDS-D System Development Plan, Rev 1.0.<sup>23</sup> This document provides guidance and focus for ADST activities as they relate to the BDS-D System. It defines the specific simulation assets, including sites and simulator devices, that will be included in the BDS-D Version 1.0 system and outlines a phased development plan.
- e. DIS Common Database Standard.<sup>24</sup> This document establishes the requirements for the CDB for the DIS system. The purpose of the DIS CDB is to provide a standard means of structuring, configuring, populating, and maintaining databases for DIS exercises and experiments.

#### 4.2.2 The Synthetic Environment and the Common Database.

System engineering also addresses the synthetic environment (virtual battlefield). The synthetic environment can be described in terms of the simulation entities and the simulated environments in which they interact. Description of the simulators, SAFOR, and other devices (assets) used to produce the simulation is by itself inadequate to provide an understanding of what the synthetic environment itself is like. A further step in this process is to identify and describe the systems replicated. For example, currently modeled weapon systems at the MWTB and AVTB are summarized in Table 4.2.2-1.

Table 4.2.2-1. Currently Modeled Weapon Systems

SYSTEM	US MODELS	OPFOR MODELS
Tank	M1A1, M1A2	T-72
Armd Pers Carrier	M2 Bradley	BMP2
Artillery	M109 (155MM)	2S3 (152MM)
Air Defense	ADATS	ZSU23-4
Mortars	M106 (4.2inch)	2S12 (120MM)
Rotary Wing	Apache, OH-58 Scout	Hind, Havoc
Fixed Wing	A-10 Thunderbolt	SU-25 Frogfoot
Engineer	M113, M57, M58, M128	PMR3, GMZ
Recovery Vehicle	M88	-
Fuel, Ammo Trucks	HEMMT	-
Tactical Ops Center	M577	-
Minefield Objects	Markers, Breech Lane	-
Anti-Tank Vehicle	LOSAT	-

The synthetic environment, however, is much more complex than a list of simulation entities. Each of these simulation entities has certain capabilities and susceptibilities which interact in meaningful ways with other simulation entities but not others. One of the activities of ADST system engineering is to discover ways of describing the public attributes of simulation entities and environments so that they may be configured into useful exercises. The Common Database (CDB) is the major architectural component responsible for this task.

The CDB is organized into three component databases. The SIMWORLD Database (SWDB) contains data relating to the description of the simulation entity and simulation asset types. The SWDB also contains information about SIMWORLD characteristics such as performance, validation, and interoperability data. The Session Database (SDB) instantiates the simulation entity types into specific simulation entities in synthetic environment scenarios. Similarly, the

SDB configures simulation assets into networks of assets (devices). The Review Database (RDB) contains data relating to the archiving of data and its subsequent analysis.

The CDB is intended to provide a flexible and extendible means of making explicit the various attributes of simulation entities (as well as simulation assets) which may affect the interoperability of the simulation. These attributes can be expressed in terms familiar to the military user, and are compatible with those found in standard military references such as TRADOC Pamphlet 11-9, Blueprint of the Battlefield.

#### **4.2.3 Simulation Verification, Validation, and Accreditation (VV&A).**

Simulation validation has been addressed through the BDS-D Feasibility Analysis Study Step 1 D.O. This effort will yield a Model Verification, Validation, and Accreditation (VV&A) plan<sup>25</sup> which is directed toward ensuring the development of a BDS-D simulation system that will be used to produce credible results for its various users. This plan could form the basis of a VV&A effort for a suitable Step 2 D.O. Key points of this plan include:

- a. A VV&A characterization database, implemented compatibly with the BDS-D database system, and containing a non-empty intersection with the SIMWORLD database.
- b. Distinct strategies for accrediting existing models and models specifically developed under BDS-D.
- c. Validation and partial accreditation for specific mission areas independent of, and in advance of, knowledge of specific experiments hosted on the BDS-D.

#### **4.2.4 Networked Simulation Standards.**

The BDS-D System relies on Industry to develop the majority of the required simulation standards. Since appropriate industrial standards are not always available when needed, or do not always include needed capabilities and services, BDS-D relies upon specific working groups to lead the effort in lobbying and guiding Industry toward incorporating the needed standards. The following (Table 4.2.4-1) is a list of the working groups currently tracked by the ADST Program.

Table 4.2.4-1. Networked Simulation Standards Activities

GROUP	SCOPE OF INTEREST	SPONSOR
Distributed Interactive Simulation (DIS)	Simulation Architecture Network Protocols Simulation Environment Communication Architecture Simulation Assessment	STRICOM (using the IST)
Defense Modeling and Simulation Initiative Groups	All aspects of Modeling and Simulation	Defense Modeling and Simulation Office (DMSO)
Joint Modeling and Simulation System(JMASS)	Modeling and Simulation Architecture	DDR&E(T&E)
Project 2851	Terrain database standards	Joint Services Air Force Lead
Multipeer Multicast Consortium	Multipeer/ Multicast promotion to International Standards Groups	Consortium Members
ALSP	Higher Order Model Communication	DARPA (using MITRE)

#### 4.2.4.1 Modular Simulator Standards.

Current plans include the development of a reconfigurable rotary wing aircraft simulator based upon the MODular SIMulator (MODSIM) standards developed under Joint Service sponsorship, lead by the Air Force (USAF Project 2968) using the Boeing Company (Aerospace and Electronics Division). The main concept important to BDS-D is the modular architecture which groups associated aircraft functions with common communication interfaces such that they may be re-used in future aircraft simulators requiring similar functionality. The JMASS group is attempting to collect and catalog simulation models with the intent of establishing a model source available to future developers of simulation devices and systems. Future editions of this document will attempt to reference available JMASS simulation models and data.

#### 4.2.4.2 Network Protocol Standards.

BDS-D will adhere to the standards developed by the DIS Working Groups. The standard required for BDS-D is the candidate IEEE Standard for Information Technology - Distributed Simulation Applications - Process and Data Entity Formats, P1278. A copy of the latest standard is maintained on-line in the ADST Bulletin Board. For information contact the Institute for Simulation and Training, 12424 Research Parkway, Suite 300, Orlando, FL 32826.

#### **4.2.5 Terrain and Sensor Databases.**

BDS-D will be supported by the Topographic Engineering Center (TEC) in the acquisition or development of terrain databases. All BDS-D terrain databases will adhere to the Standard Interface Format (SIF) developed under Project 2851. Information regarding Project 2851 activities and standards may be obtained by contacting COL Richard Tebay, ASD/YWSA. SIMNET terrain databases are summarized in Table 4.2.5-1.

Table 4.2.5-1. SIMNET Terrain Databases

NAME		SOURCE	DEV. TOOL	AREA COVERED	AVTB	MWTB	VERSION
Ft. Knox	3 KM OTW View 7 KM Thermal 7 KM OTW View MCC SAFOR Mips SAFOR Symbolics World	BBN	S1000	50km Y - 75km X	✓ ✓ ✓ ✓ ✓ ✓	✓ ✓ ✓ ✓ ✓ ✓	knox3cow.001 knox7cdh.001 knox7coh.001 KNOX.0311 KNOX.0311 Knox-Terrain 8.0
Ft. Hunter Liggett	3 KM OTW View 7 KM Thermal 7 KM OTW View MCC SAFOR Mips SAFOR Symbolics World	BBN	S1000	50km by 50km	✓ ✓ ✓ ✓ ✓ ✓	✓ ✓ ✓ ✓ ✓ ✓	hunt3cow.001  HUNTER.0110 HUNTER.0110 Hunter-Liggett 6.0
NTC	3 KM OTW View 7 KM Thermal 7 KM OTW View MCC SAFOR Mips SAFOR Symbolics World		S1000	50km by 50km	✓ ✓ ✓ ✓ ✓ ✓	✓	ntc3cow.001
D sub saki	3 KM OTW View 7 KM Thermal 7 KM OTW View MCC SAFOR Mips SAFOR Symbolics World	TEC	S1000	80km Y - 96km X	✓ ✓ ✓ ✓ ✓ ✓	✓ ✓ ✓ ✓ ✓ ✓	dsub3cow.006  ds_sub_0102 ds_sub_0102 DS_Terrain 2.0
Ft. Hood	3 KM OTW View 7 KM Thermal 7 KM OTW View MCC SAFOR Mips SAFOR Symbolics World	BBN	S1000	50 km by 50 km		✓ ✓ ✓ ✓	hood3cow.00c  Hood.0103 Hood.0103 Hood Terrain 2.0
Bergen Hochne	3 KM OTW View 7 KM Thermal 7 KM OTW View MCC SAFOR Mips SAFOR Symbolics World		S1000	25km by 25km		✓	berg3cow.001

#### **4.2.6 Tape Backup Library.**

A tape backup library will be maintained under the SSL and CM control for all software packages used on the development and target machines.

#### **4.2.7 Technical Reference and Training Library.**

CM will maintain a library of technical manuals, text books, video cassettes, and vendor manuals needed to support the software development program.

#### **4.2.8 Software Reuse.**

The SSL supports a central point library collection, maintenance, and distribution of reusable software parts. Software that is developed as a result of other build configurations may be used in another application with little or no modification. The software parts are made up of reusable software components and support documentation where applicable. An example of software reuse under the BDS-D umbrella is the GT M1 code. This code has been applied to the M1/XROD delivery order, the CVCC delivery order, and the VIDS delivery order. RWA is another example of code used on other delivery orders such as ATAC II and the Commanche upgrade. In addition, the SSL for the SIMNET baseline has an identified common library where databases, data files, and weapon applications are pulled into various configurations. In addition, reusable software includes design documentation and Cold Start Procedures. All reusable software on ADST is subject to the same maintenance and change control activities as all other baselined code.

#### **4.2.9 Software Support.**

The vehicles for software support are largely through D.O.s and the Software Contract Change Proposal (CCP).

### **4.3 Information Services.**

This section discusses the capabilities for technical information access and exchange provided for under the ADST contract. A major portion of this activity will be migrating the SIMNET baseline system to the BDS-D system. With this move towards an open-systems architecture and standardized interfaces, it is anticipated that larger sectors of Government, Industry, and Academia will be participating in the design, development, production, and analysis of activities covered under the ADST program. To facilitate synergy among these diverse and

distributed groups, it is essential to maintain a flow of information. ADST provides several methods for dealing with this information management and communications challenge.

#### **4.3.1 ADST Technical Library.**

Another LSE task is the creation, maintenance, and enhancement of the ADST Technical Library. This library is one of the information distribution mechanisms that is needed to facilitate the transition to the open system architecture. The library gathers into one place the system description information and information related to and supporting ADST initiatives. This includes all of the deliverables created by ADST initiatives, other documentation by the DIS community, and an historical repository of SIMNET information.

The initial base of the collection was historical information related to the currently fielded SIMNET system. This information had to be gathered and evaluated, and as a result it was discovered that:

- a. No one site had a complete set of the available system documentation.
- b. Confidence in documents validity in relation to the current system varied.
- c. Not all systems were documented to the level necessary to perform maintenance.
- d. It was not clear which version of the software documents were related to.
- e. Documents necessary for requirements tracking were not present for all systems.

As depicted in Figure 4.3.1-1, the initial task was to place under configuration management the existing system documentation. This required gathering information from primary sources: STRICOM, Fort Knox, Fort Rucker, IST, and IDA. IDA had the most complete library, with over 2000 entries that have been screened and added to the ADST library as appropriate. STRICOM had over 260 documents and other media in their SIMNET library that had been duplicated and included in the library. IST had over 160 documents in their library; those unique to that library have been duplicated. Fort Knox had over 300 documents and Fort Rucker over 100. The unique documents have been identified and reproduced.

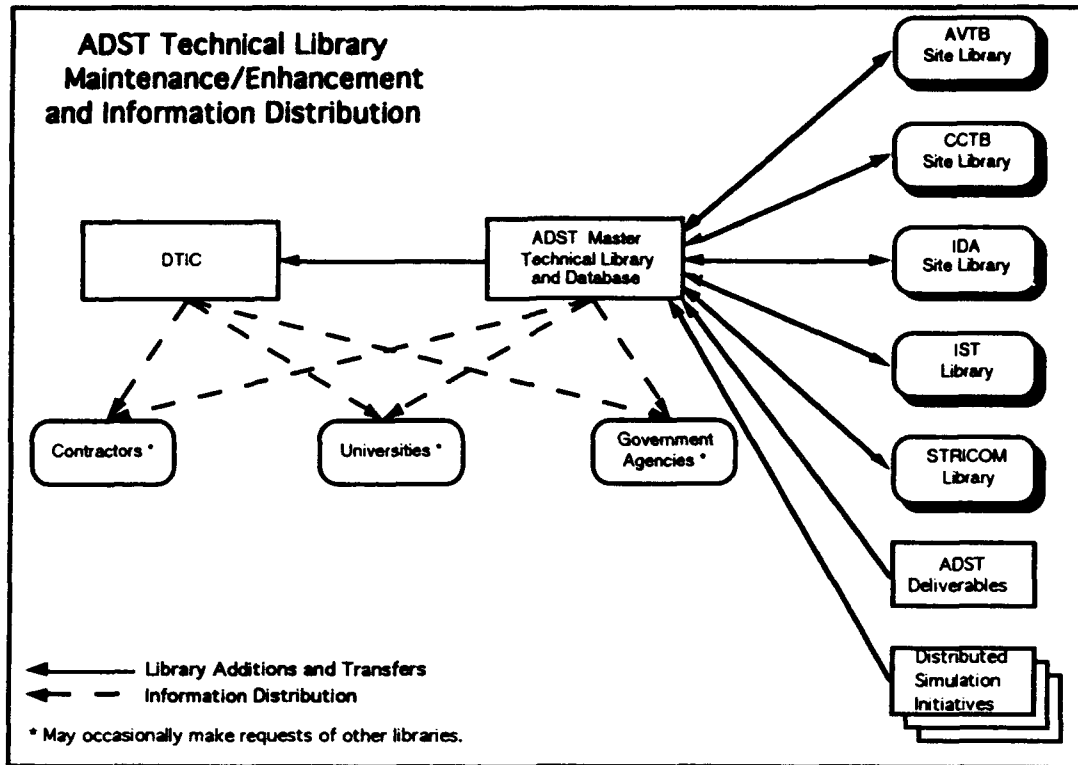

Figure 4.3.1-1. Technical Library Maintenance and Information Distribution

To place the documents and other material under configuration management, a database management system (DBMS) has been developed to track document information. This design will facilitate making old and new reports available to DTIC. Each document in the library is assigned a standard technical report number (STRN) in accordance with ANSI/NISO Z39.23-1990. Each document also retains its identification numbers from the other libraries.

After the creation of the base library at the ADST PMO, the challenges are to make the distribution of information in the library cost-effective and to keep it (and the supporting libraries) up to date. The library inventory DBMS will facilitate both of these objectives. Sites will have on-line access to update the database via EIEN. This will allow the sites to update their on-hand library holdings, browse and request entries in the ADST Master Library, and recommend entries for inclusion in the master library. Data from the DBMS will be uploaded to the BBS where anyone can search/browse the inventory information.

The general policy for gaining access to library materials is that a requester will check out material for a 24 hour period. During this time, requesters can use the material and/or have the material reproduced. An inventory of what is available is maintained on the bulletin board and is available at the ADST PMO. Special arrangements may have to be made in some instances, i.e., for magnetic media.

#### **4.3.2 ADST Bulletin Board System (BBS).**

##### **4.3.2.1 Bulletin Board Configuration.**

The ADST Bulletin Board System (BBS) is a primary means of making technical information available to a wide community of users. The BBS posts information to keep the community up to date on ongoing activities, and also serves as a tool for working groups in specific content areas. Table 4.3.2.1-1 is a brief outline of the topic areas available on the BBS.

Table 4.3.2.1-1. ADST BBS Configuration

<b>ADST Bulletin Board System</b>	
<b>Distributed Simulation Initiatives</b>	
SIMNET to DIS Protocol Translator	IST LOSIM Steering Committee (Private)
Estelle Specification Project	DIS Conference Minutes
ALSP - Aggregate Level Simulation	IST Coordinate Xform SW
<b>Protocol</b>	
<b>DIS Architecture</b>	
DIS Architecture Comments	
Volume I: Summary Discription	
Volume II: Supporting Rationale Book I: Time/Space Coherence	
Volume II: Supporting Rationale Book II: DIS Architecture Issues	
<b>DIS Standard Documents</b>	
Rational Document	
DIS Standard 2.0 First Draft	
DIS Standard 2.0 Second Draft	
DIS Standard 2.0 Third Draft #209 (2)	
<b>DIS Software</b>	
ADA Code	
C Code	
Comments on DIS Software	
<b>DIS Testing</b>	
DIS Test Plan V5.0	
IITSC '92	
<b>Battlefield Distributed Simulation - Developmental</b>	
BDS-D User's Guide	
DIS Compliance and Capability	
Common Database Standard 1.1 (MS Word for Mac)	
<b>IST Computer Generated Forces</b>	
IST CGF V4.210	9-30 PDU Streams
IST CGF V6.0 (DIS)	10-22 data logger update
IST CGF V6.002 Update	IST CGF V6.400
Utilities	IST CGF V6.405 (IEEE 1278 Std)
Terrain Data Bases	IST CGF V6.407 (DIS 2.0.3 Std)
<b>Position Papers</b>	
Recommended Approach for Standardizing DIS Data Base Color...	
Army Air Defense Challenges to the DIS Standard	
ANALYSIS OF THE DIS PROTOCOL FOR DARPA's PROJECT HY-DY	
Euler Angle & Rotation Matrix Conversion between DIS and SIM...	
SIMNET Local Coordinate - DIS 1.0 Geocentric Coordinate Tran...	
<b>ADST Technical Library</b>	
This report provides a listing of the documents available in the LORAL ADST Technical Library.	
<b>Upcoming Conferences</b>	
9th DIS Conference	
<b>Comments and Discussions</b>	
Add messages to this area if you have any questions. Or if you have suggestions on information you would like to see maintained on the BBS, topic areas that you would like to see added or other comments.	

To facilitate communication among members of the simulation community, a listing of Internet Electronic Mail addresses is maintained on the ADST Bulletin Board System. Messages and brief position papers may be passed easily among interested BBS subscribers.

All BBS users will have to be registered to ensure accountability and network security. There are no "guest" or "anonymous" accounts. All users requesting access to the BBS will have to fill out a registration request form. This form will be sent to the Loral ADST office in Orlando. Upon receipt of the registration form, the user will be added to the BBS system and will be assigned a password. The user's password and other pertinent BBS information will be sent, to the user via U.S. Mail. Once users receives this information, they can log on to BBS and change their password to something only the user knows.

The BBS is configured by Groups and Sub-Groups. Each Group and Sub-Group may have multiple Sub-Groups under it. Each Group and Sub-Group will have a responsible person as the administrator. The "administrators" will not be the BBS System Administrators, but will be actual users with authority over the Group and Sub-Groups. Systems Administration will be required only to create Groups, not Sub-Groups.

These groups can be Read or Read/Write for all users or only specified users. Read and Read/Write users can also be mixed in the same Group or Sub-Group.

#### **4.3.2.1.1 ADST BBS Components.**

This BBS is available 24 hours a day via Dial-In and Internet. A block diagram of the BBS components is shown in Figure 4.3.2.1.1-1. BBS equipment is summarized in Table 4.3.2.1.1-1. The INTERNET address of the BBS is 137.249.32.17. The BBS modem telephone number is (408) 428-9470. The following suite of hardware supports the BBS.

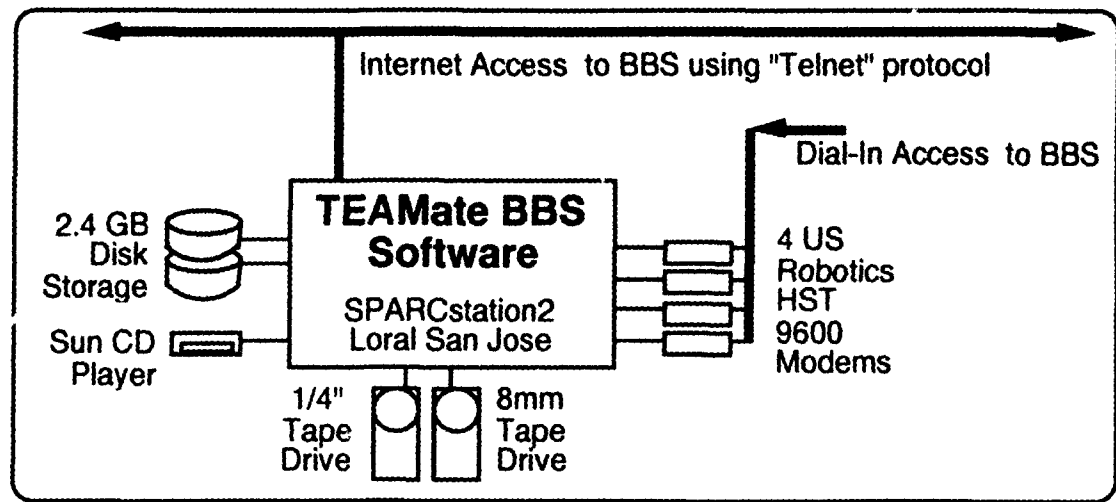

Figure 4.3.2.1.1-1. ADST BBS Block Diagram

Table 4.3.2.1.1-1. BBS Equipment

QUANTITY	EQUIPMENT TYPE	PURPOSE	
1	Sun SPARCstation 2	BBS Server  64 MB Memory 2.4 GB Disk Storage 2.3 GB 8mm Tape Storage 150MB 1/4" Tape Storage Sun CD Player	For BBS application and file storage. For backup and information upload and download. For backup and information upload and download. For system use and information upload.
4	US Robotics HST 9600 Modems	Self-adjusting in speed and protocol to support  V42, V42bis MNP-5 Compression/ Error Correction	currently manufactured modems at the highest speed available to both modems.
2	Telebit TrailBlazer + Modems	UUCP Support. Self-adjusting in speed and  V42, V42bis MNP-5 Compression/ Error Correction	protocol to support currently manufactured modems at the highest speed available to

Table 4.3.2.1.1-2. TEAMate Features

FEATURE	FUNCTION
Point and Select Outline Database	Unique TEAMate feature for ease of use.
User Interface	Full Screen cursor controlled. Forms for data entry. Context sensitive help. User interface may be customized.
Simultaneous Users	Unlimited. Restricted only by host capacity
Electronic Mail	Included with cc:, bcc:, groups, auto receipt notification, foreign mail gateways.
Bulletin Boards	Easy to use topic (menu) oriented with definable access permissions. Group and individual membership.
Computer Conferences	Topic oriented electronic meetings.
Chat	Interactive group discussions with scrollable and saved transcripts. Easy dual window interface.
Private Topics	Membership in topics can be limited.
Immediate Indexing	All information is indexed upon creation for immediate retrieval.
Content Retrieval	Retrieval on subject, author, keywords, reference, topic, creation date, expire date. Full text retrieval optional.
Viewable Indexes	All indexes may be viewed with frequency counts.
Data Transfer	Transaction processor supports loading/unloading bulk data.
Dynamic Data Reorganization	All data can be reorganized on-line. Owners can change the structure. Menu items (topics) can be hoisted or lowered as desired.
Binary Files and Downloads	Unlimited download libraries. Compound entries supported for attaching descriptive text to binary files.
Audit Trails	Topic and Entry tracking.
Network Support	Modems (all speeds), X.25 and local high speed networks
Word Processors	TEAMedit provided and all UNIX editors and word processors supported.
System Operation	Administrative functions built in. User directory maintained by TEAMate. All functions can be performed while system is in full operation.
Customization	Screen layouts, command names, command deletion, help files. No customization required for standard operation.
Forms	Form builder permits building customized data input forms.
Terminal Emulation	Supports all cursor addressable terminals. TEAMterm, MS-DOS communication program, provided with unlimited duplication license.

### 4.3.3 Defense Technical Information Center (DTIC).

The ADST contract has become a registered user of DTIC; documents can requested and submitted. The submission of documents to DTIC is aided by the information gathered and tracked in the ADST Technical Library.

**5 .i. REFERENCES.**

- 1 **BDS-D Program Plan.**
- 2 **Strawman DIS Architecture Description Document.** ADST/WDL/TR-92-003010, 3 volumes, Loral Systems Company, March 1992.  
  
**DIS Architecture Description Document.** Version 1.0, ADST/WDL/TR-93-003010, Loral Systems Company, May 1993.
- 3 **BDS-D User's Guide: A Guidebook for Agencies Conducting Research Using Battlefield Distributed Simulation-Developmental (BDS-D).** Loral Systems Company, 5 May 1993.
- 4 **ADST Delivery Order Summaries.** Loral Systems Company, August 1993.
- 5 **SIMNET Combat Vehicle Command and Control (CVC2) System.** BBN, December 1990.
- 6 **SIMNET CVCC IVIS Utilities User Manual.** BBN Report No. 7631, July 1991.
- 7 **SIMNET Data Logger.** BBN Report No. 7617, June 1991.
- 8 **SIMNET Master Documentation.** Perceptronics, 5 September 1986.
- 9 **Technical Report No. PTR-4070-11-8200-91/2.** Perceptronics, SIMNET, 5 February 1991.
- 10 **SIMNET Manual No. PTUM 001-1250-89-10 (Rev.2).**
- 11 **Integrated Test Plan - SIMNET.** R4-91-01904-001, 18 June 1991.
- 12 **SIMNET Manual No. PTUM 002-1250-89-10 (Rev.1).**
- 13 **SIMNET Plan View Display.** BBN Report No. 7618, June 1991.
- 14 **Semi-Automated Forces (SAF) Commander Training, SIMNET.** Perceptronics, 11 March 1991. (SAFOR version 3.10.6 released on 15 July 1991 by BBN.)
- 15 **Software Design Document, MCC CSCI (1).** 2 volumes, BBN Systems and Technologies, June 1991.
- 16 **Software Design Document, NOM CSCI (2).** 1 volume, BBN Systems and Technologies, June 1991.
- 17 **Software Design Document, PVD CSCI (3).** 2 volumes, BBN Systems and Technologies, June 1991.
- 18 **Software Design Document, Data Logger CSCI (4).** 1 volume, BBN Systems and Technologies, June 1991.
- 19 **Software Design Document, Vehicle Simulation CSCI (5).** 4 volumes, BBN Systems and Technologies, June 1991.
- 20 **Software Design Document, SAF Workstations CSCI (6).** 2 volumes, BBN Systems and Technologies, June 1991.

- 21 Software Design Document, SAF Parameter Editor CSCI (7). BBN Systems and Technologies, June 1991.
- 22 Software Design Document, SAF Simulator Host CSCI (8). BBN Systems and Technologies, June 1991.
- 23 Software Design Document, CIG Host CSCI (9a). 1 volume, BBN Systems and Technologies, June 1991.
- 24 Software Design Document, GT Realtime SW Host CSCI (9b). 1 volume, BBN Systems and Technologies, June 1991.
- 25 The SIMNET Network and Protocols. Arthur R. Pope, BBN Systems and Technologies Corporation, June 1991.
- 26 1278-1993, Standard for Information Technology, Protocols for Distributed Interactive Simulation Applications. IEEE, New York, NY, March 1993.
- 27 Proposed IEEE Standard Draft: Standard for Information Technology - Protocols for Distributed Interactive Simulation Applications. version 2.0 - Third Draft, IST-CR-93-15, UCF Institute for Simulation and Training, 28 May 1993.
- 28 Configuration Management Plan. Version 1.3, Loral Systems Company, ADST/WDL/TR-92-003023, 1/15/93.
- 29 Strawman DIS Architecture Description Document. ADST/WDL/TR-92-003010, 3 volumes, Loral Systems Company, March 1992.
- 30 System Design Specification for the Battlefield Distributed Simulation - Developmental (BDS-D) System. Version 1.0., Loral Systems Company, ADST/WDL/TR-93-W003068, 28 May 1993.
- 31 Distributed Interactive Simulation Architecture Description Document, Volume I: Summary Description. Loral Systems Company, ADST/WDL/TR--93-003010, 28 May 1993.
- 32 System Design ICD for the BDS-D System. Version 1.0., Loral Systems Company, ADST/WDL/TR-93-W003069, 28 May 1993.
- 33 BDS-D System Development Plan. Rev 1.0., Loral Systems Company, ADST/WDL/TR--93-003044, 25 February 1993.
- 34 Distributed Interactive Simulation Common Data Base Standard (Draft). Loral Systems Company, ADST/WDL/TR-93-W003077, 28 May 1993.
- 35 Battlefield Distributed Simulator-Developmental (BDS-D) Model Verification, Validation, and Accreditation Plan. BDM International, Inc. BDM/ABQ--92-0073-TR, 10 November 1992.

**APPENDIX A: RESEARCH AREAS**

This appendix addresses research areas which are listed in the ADST SOW which are being addressed by D.O.s. Further information about the D.O.s is listed in Table A-1 below.

Table A-1. ADST Research Areas

<b>RESEARCH AREA</b>	<b>ADST ACTIVITIES</b>	<b>COMMENTS</b>
Battle Simulation for Individuals, Crews, and Units	CVCC, CSRDF	
Cost Effective Long Haul Networking Capability	BDS-D, CSRDF	BDS-D Network architecture; CSRDF demonstration.
Networking of Simulators with Varying Levels of Resolution	CSRDF	NASA-Ames and AVTB rotary wing simulators
Networking of Manned Simulators and Computer Simulations	BDS-D IHOM	Demonstration planned for IHOM Step 2.
Seamless Simulation Between Manned and Automated Simulators, and Field/Command Post Exercises	BDS-D CGF	Integration of Manned and Automated Simulators only; FTX and CPX not yet addressed.
Low Cost Visual Simulation Technology	BDS-D DIS V&V	
Rapid Terrain Database Generation		
Tactics, Technology, and Virtual Prototypes in a Low Cost, Variable Resolution, Modular Developmental Test Bed	X-ROD, VIDS	X-ROD developing virtual prototype and COEA.VIDS survivability systems prototyping
Instructional System Development Procedures		
Man-machine Interface, e.g., MANPRINT	AirNet Conversion	Task analysis
Embedded Training and Actual Equipment in Distributed Simulation	N/A	
Human Performance and Measurement		
Reconfigurable and Prototype Combat Vehicle, Aviation, and Shipboard Combat System Control Simulators	AirNet Conversion	Reconfigurable simulators
System Requirements Analyses Methods		
Analytical Methodologies for "man in the loop training"	N/A	
Emerging Development in Display Technology	BDS-D, AirNet Conversion	
Computer, Electronic and Mechanical Systems	AirNet Conversion	
Engineering Management Systems	N/A	
Training Technologies	BDS-D	
Artificial Intelligence	BDS-D CGF	

---

**APPENDIX B: ADST POINTS OF CONTACT**

**USA STRICOM:**

**12350 Research Parkway**

**Orlando, FL 32826-3276**

Mr. Stan Goodman, BDS-D Program Manager

(DSN) 960-8165, (407) 380-8165, FAX: (407) 380-4258

e-mail: goodmans@orlando-emh7.army.mil

Mr. Gene Wiehagen, COTR

(DSN) 960-4363, (407) 380-4363, FAX: (407) 380-4258

e-mail: wiehageg@orlando-emh4.army.mil

Mr. John Collins, COTR

(DSN) 960-4382, (407) 380-4382, FAX: (407) 380-4258

e-mail: collinsj@orlando-emh4.army.mil

**Loral ADST Program Management Office**

**12443 Research Parkway, Suite 303**

**Orlando, FL 32826**

Mr. Warren Richeson, ADST Program Manager

(407) 382-4581, FAX: (407) 382-4592

e-mail: richeson@orlando.loral.com

**Mounted Warfare Test Bed**

**2021 Blackhorse Regiment Ave.**

**Fort Knox, KY 40121**

Mr. Tom Radgowski, Site Manager

(502) 942-1092, FAX: (502) 942-1696

e-mail: radgowski@vox.knox.loral.com

**Aviation Test Bed Facility**

**PO Box 385**

**Fort Rucker, AL 36362**

Mr. John Miller, Site Manager

(DSN) 558-2234, (205) 598-3066, FAX: (205) 598-5370

e-mail: miller@charm.isi.edu

**APPENDIX C: DELIVERABLES AND PRODUCTS BY DELIVERY ORDER**

<b>DATES</b>	<b>DELIVERY ORDER</b>	<b>DELIVERABLES/ PRODUCTS</b>
04/91 - 08/91	CVCC STEP 1 D.O.	Feasibility Analysis Study
04/91 - 09/91	RWA STEP 1 D.O.	RWA Design
05/91 - 02/93	DOTD STEP 2 D.O.	Final Report Submitted
07/91 - 06/92	MULTIRAD STEP 2 D.O.	Protocol Extension to SIMNET Submitted Long Haul Network Submitted Network Performance Analysis Submitted Computer Software Product Submitted
10/92 - 02/92	RWA STEP 2	CWBS Submitted System/Segment Spec Submitted Development DES DWGs and Assoc Lists Design Criteria List Submitted System Safety Program Plan Safety Assessment Report Software User's Manual Facility Design Criteria Doc Test Plan/Proc Test Plan/Proc Recommended Spares/Supt Equip
08/91 - 07/93	CVCC STEP 2	Test Plan for HW/SW/INT (submitted 10-18-91) Test Plan for HW/SW/INT (submitted 03-16-92) Test Results: HW/SW/INT (submitted 08-01-92) Test Results: HW/SW/INT (submitted 10-01-92) ECR Workstation Manual Update (submitted) Utilities Manual Update (submitted) Hardware Users Guide (submitted) Research Report (submitted 09-12-92) Research Report Govt. Furnished Research Plan/ Support Package Software Users Guide (submitted) Software Architecture Description (submitted) Innovative Training Methods (submitted) Innovative Training SW Description (submitted) Briefing Slide Library (submitted)
10/91 - 03/92	BDS-D STEP 1 D.O.	Provide Technical Report Provide Cost Proposal
10/91 - 05/92	LSFBD STEP 1 D.O.	Reconfigurable Sim Funct Req Doc Reconfigurable Sim Des Data Handbook Reconfigurable Sim Funct Spec SIMNET-JANUS Intercon Desc Data Handbook SIMNET-JANUS Test Scenario SIMNET-JANUS Funct Req Doc
11/91 - 07/93	X-ROD STEP 2 D.O.	Outline Test Plan Draft Funct Spec Test Des Plan Phase 2 Approach/Schedule Detailed Test Plan Final Functional Spec Doc HW/SW Mod Doc
10/91 - 01/92	CSRDF STEP 1 D.O.	

03/92 - 06/93	CSRDF STEP 2 D.O.	Step 2 Requirement Doc ICD Step 2 Proposal FAS Report
06/92 - 07/92	VIDS STEP 1 D.O.	Step 2 Proposal Feasibility Analysis Report

**APPENDIX C: DELIVERABLES AND PRODUCTS BY DELIVERY ORDER  
(CONTINUED)**

<b>DATES</b>	<b>DELIVERY ORDER</b>	<b>DELIVERABLES / PRODUCTS</b>
04/92 - 02/93	LEAVENWORTH STEP 2 D.O.	Requirements Specification Requirements Specification Feasibility Report Feasibility Report
06/92 - 07/93	AirNet STEP 2 D.O.	Design Criteria List S/W Maintenance Manual Test Plans/ Procedure (prelim) Test Plans/ Procedure (final) Rec Spares and support Equip Software Design Doc MCC Operator's Manual AirNet Conversion Dev Des Dwgs and Assoc Lists (prelim) Dev Des Dwgs and Assoc Lists (final)
07/92 - 06/93	BDS-D STEP 2 D.O.	Arch Def Phase 2 Plan DIS Arch Standards Phase 2 Plan DIS Architecture Description Doc BDS-D Ver. 1.0 Sys Des Spec BDS-D Ver. 1.0 Sys Des ICD Common Database Standard DIS PDU EXTENSION DIS Correlation Metrics BDS-D System Plan Intg w/BDS-D Ver 1.0 Sys Phase 2 Plan Large Scale Exercise Plan Phase 2 Plan for fully Represented Theater Component Demo Test Plan Component Demo Report DIS Demo Test Plan DIS Demo Report Outline Plan and Brief S/W Des, Sys A Code Doc and Reports
07/92 - 07/93	WARBREAKER STEP 2 D.O.	Comp SW Prod End Items Software Design Document Software Design Document Protocol Extension to DIS Network Analysis Network Analysis Software User's Manual Interface Design Document Final Report

07/92 - 08/93	VIDS STEP 2 D.O.	Software Design Doc Software Maintenance Manual Operators/users Manual Test Plan Test Report
09/92 - 09/93	NLOS STEP 2 D.O.	Test Plan Design Drawings (draft) Design Drawings (final) Operator and Maint Manual Software Design Doc Test Report Software Reference Manual
09/92 - 03/93	SMART MINES STEP 2	Technical and Management Work Plan Technical Report (draft) Technical Report (final)

**APPENDIX C: DELIVERABLES AND PRODUCTS BY DELIVERY ORDER  
(CONTINUED)**

<b>DATES</b>	<b>DELIVERY ORDER</b>	<b>DELIVERABLES / PRODUCTS</b>
09/92 - 04/93	BSD STEP 2 D.O.	Hardware Drawings Operator's Manual Change Pages Technical Manual Change Pages Final Report Software Design Document
11/92 - 10/93	MODSAF STEP 2 D.O.	Programmers Reference Manual - D Programmers Reference Manual - F SAFOR Operator Users Manual - D SAFOR Operator Users Manual - F Computer System Operations Manual - D Computer System Operations Manual - F Interface Control Document - D Interface Control Document - F System Requirements Specification Acceptance Test Procedure - D Acceptance Test Procedure - F Version Description Document Installation Plan - D Installation Plan - F Training Plan - D Training Plan - F Maintenance Plan - D Maintenance Plan - F Recommended Spares List
05/92 - 05/92	SASC DEMO STEP 2 D.O.	
10/92 - 10/92	LOSAT/SAFDI DEMO	
08/92 - 03/93	JAYHAWK THUNDER	Stage 1 Report Final Report Software Description Document

09/92 - 01/94	CVCC 93	Final Research Report (draft) Final Research Report (final) Software Architectural Document
01/93 - 01/94	BRIEFING D.O.	
06/92 - 08/92	M1A2 SUPERTHREATS	
12/92 - 03/93	SEAMLESS SIMULATION EXP	After Action Report
03/93 - 02/94	DOS	Test Report
03/93 - 07/93	PVI	Test Report
04/93 - 08/93	TEST BED EXPANSION	
05/93 - 11/93	VIDS PHASE II	Software Design Document Software Maintenance Manual Operators/Users Manual Test Plan Test Report
05/93 - 11/93	SKALNOTTY	Software Design Document Technical Manual Operator and Maintenance Manual Dev Des Drwgs and Assoc Lists Test Report
03/93 - 06/93	CTPS (AUSA MAY)	

**APPENDIX C: DELIVERABLES AND PRODUCTS BY DELIVERY ORDER  
(CONTINUED)**

<b>DATES</b>	<b>DELIVERY ORDER</b>	<b>DELIVERABLES / PRODUCTS</b>
05/93 - 08/94	PROJECT SWORD	
06/93 - 03/94	A/S PHASE 2	DIS Interface Package LAN FDDI Analysis and Product Select DIS Test Tools Documentation DIS CIU Documentation DIS CAU for Virtual Cell BDS-D Simworld Basic Database BDS-D Architecture Expansion Updates DIS Standards Extension for BDS-D
06/93 - 08/93	M1A2 DIFFERENTIAL	
06/93 - 01/94	NATIONAL GUARD	
06/93 - 01/94	ARWA PHASE 1	
07/93 - 12/94	MULTIRAD/CAS	
02/93 - 11/93	05/06 TOC	

**APPENDIX D: ACRONYMS**

The acronyms list contains relevant technical terms from the architecture, SIMNET, DIS, the contract, and the various D.O.s.

ADATS	Air Defense Anti-Tank System
ADL	Ada Design Language
ADST	Advanced Distributed Simulation Technology
AFB	Air Force Base
AIT	Air Intercept Trainer
ALSP	Aggregate Level Simulation Protocol
AMSAA	Army Material Systems Analysis Activity
ARDEC	Armament Research Development and Experimentation Center, Picatinny Arsenal
ARI	Army Research Institute
ASD	Aeronautical Systems Division (of USAF)
ATAC II	Air to Air Combat II
ATAS	Air to Air Stinger
ATCOM	Aviation and Troop Command
AVTB	Aviation Test Bed
ATES	Automated Threat Engagement System
ATCOM	Aviation and Troop Command
AWACS	Airbourne Warning and Control System
BARRNet.	Bay Area Regional Research Network
B&W	Black and White
BBN	Bolt, Beranek, and Newman
BBS	Bulletin Board System
BCIP	Battle Command Integration Program
BDS-D	Battlefield Distributed Simulation - Developmental
BFV	Bradley Fighting Vehicle
BOS	Battlefield Operating System
CAC	Combined Arms Command
CADIS	Computer Architecture for Distributed Interactive Simulation
CAS	Close Air Support
CASS	Communication Architecture and Security Subgroup
CCB	Configuration Control Board
CCP	Contract Change Proposal
MWTB	Mounted Warfare Test Bed
CCTR.	Command and Control Training Research
CCTT	Close Combat Tactical Trainer
CDRL	Contract Data Requirements List
CET	Combat Engagement Trainer
CGF	Computer Generated Force
CGSC	Command and General Staff College
CIG	Computer Image Generator
CITV	Commander's Independent Thermal Viewer
CIU	Cell Interface Unit
COFT	Conduct of Fire Trainer
CONOPS	Concept of Operations
CM	Configuration Management
CMT	Critical Mobile Targets

**APPENDIX D: ACRONYMS (continued)**

CPG	Co-Pilot/Gunner
CPO	Co-Pilot/Observer
CPX	Command Post Exercise
CR	Change Report
CSC	Computer Software Component
CSCI	Computer Software Configuration Item
CSRDF	Crew Station Research and Development Facility
CSS	Combat Service Support
CTAS	Counter Target Acquisition System
CVCC	Combat Vehicle Command and Control
DAC	Digital to Analog Converter
DARPA	Defense Advanced Research Projects Agency
DBMS	Database Management System
DCD	Director of Combat Development
DDR&E	Deputy Director (of Defense) for Research and Engineering
DIS	Distributed Interactive Simulation
DMSO	Defense Modeling and Simulation Office
DN	Discrepancy Notice
DS, DD	Double Sided, Double Density
DSI	Defense Simulation Internet
DTIC	Defense Technical Information Center
D.O.	Delivery Order
DOD	Department of Defense
ECO	Engineering Change Order
ECP	Engineering Change Proposal
EIEN	Electronic Information Exchange Network
EPLRS	Enhanced Position Location and Reporting System
EW	Electronic Warfare
FAADS	Forward Area Air Defense System
FBL	Future Battle Laboratory
FCA	Functional Configuration Audit
FDT&E	Field Developmental Test and Evaluation
FLIR.	Forward Looking InfraRed
FOG-M	Fiber-Optic Guided Missile
FOV	Field of View
FSE	Fire Support Element
FTP	File Transfer Protocol
FTX	Field Test Exercise
FWA	Fixed Wing Aircraft.
GADD	Generic Air Defense Device
GCI	Ground Control Intercept.
GDLS	General Dynamics Land Systems
GFE	Government Furnished Equipment
GPS	Gunner's Primary Sight.
GPS	Global Positioning Satellite
HEAT	High Explosive Anti-Tank
HEL	Human Engineering Laboratories
HEMTT	Heavy Expanded Mobility Tactical Truck
HMMWV	High Mobility Multipurpose Wheeled Vehicle
HRA	Human Resources (Laboratory) "A"
HUD	Heads-Up Display
ICD	Interface Control Document

**APPENDIX D: ACRONYMS (continued)**

I-COFT	Individual - Conduct of Fire Trainer
IDA	Institute for Defense Analysis
IFV	Infantry Fighting Vehicle
IHOM	Integration of Higher Order Models
IIR	Imaging InfraRed
IP	Internet Protocol
IST	Institute for Simulation and Training
ISU	Integrated Sight Unit
ITT	Integration and Test Team
ITV	Improved TOW Vehicle
IVIS	Inter-Vehicular Information System
JMASS	Joint Modeling and Simulation System
JSTARS	Joint Surveillance Target Attack Radar System
LAN	Local Area Network
LCAC	Low Cost Auxilliary Cockpit
LDN	Local Data Network
LOSAT	Line of Sight Anti-Tank
LSE	Laboratory Sustaining Effort
MCC	Management, Command and Control
MILNET	Military Network
MORS	Military Operations Research Society
MPET	MultiPlatform Engagement Trainer
MPMC	MultiPeer/MultiCast
MULTIRAD	Multiship Research and Development (Facility)
NCCOSC	Naval Command, Control, and Ocean Surveillance Center
NETT	New Equipment Training Team
NIU	Network Interface Unit
NLOS	Non-Line-Of-Sight
NOM	Network Operations and Maintenance
NRaD	Navy Research and Development
NFS	Network File System
NSC	National Simulation Center
NSFNET	National Science Foundation Network
NTC	National Training Center
NTSC	Naval Training Systems Command
OOS	Operational Operating Systems
OPFOR.	Opposing Force
OPORDERS	Operation Orders
OPS	Operations
OTW	Out The Window
PCA	Physical Configuration Audit
PDL	Program Design Language
PICT	a graphic format standard
POSNAV	Position Navigation
PDU	Protocol Data Unit
PMO	Program Management Office
POC	Point of Contact
PVD	Plan View Display
RCS	Revision Control System
RDT&E	Research, Development, Test and Evaluation
RPA	Rotocraft Pilot's Associate
RWA	Rotary Wing Aircraft

**APPENDIX D: ACRONYMS (continued)**

SAAC	Simulator for Air to Air Combat
SAF	Semi-Automated Forces
SAFOR	Semi-Automated Forces
SAKI	Saudi Arabia, Kuwait and Iraq (terrain database)
SAS	Statistical Analysis System
SCC	Simulation networking Control Consoles
SCM	Software Configuration Management
SCN	Specification Change Notice
SCRB	Software Configuration Review Board
SCTB	Simulator Complexity Test Bed
SDF	Software Development Facility
SHORAD	Short Range Air Defense
SIF	Standard Interface Format
SIMNET	Simulation Networking
SIMWORLD	Simulation World
SMI	Soldier Machine Interface
SMS	Smart Minefield Simulator
SINCGARS	Single Channel Ground and Airborne Radio System
SOP	Standing Operating Procedure
SP	Software Problem
SPR	Software Problem Report
SRC	Source (code)
SSL	Software Support Library
SSOP	Software Support Operating Procedures
STRICOM	Simulation, Training and Instrumentation Command
STRN	Standard Technical Report Number
T&E	Test and Evaluation
TACOM	Tank Automotive Command
TCP	Transmission Control Protocol
TEC	Topographic Engineering Center
TNE	Threat and Natural Environment
TOC	Tactical Operations Center
TOR	Technical Oversight Representative
TOW	Tube-launched, Optically Wire-guided
TRAC	TRADOC Analysis Center
TRADOC	US Army Training and Doctrine Command, Fort Monroe
USA.	United States Army
USAF	United States Air Force
UTP	Unshielded Twisted Pair
VADPC	Video/Audio Data Production Center
VTRS	Visual Technology Research Simulator
V&V	Verification and Validation
VHS	Video Home System
VIDS	Vehicle Integrated Defense System
VMS	Virtual Machine System (DEC Operating System)
VV&A	Verification, Validation, and Accreditation
WAN	Wide Area Network
WAREX	War Exercise
WDL	Western Development Laboratories (a Loral Company)
WISSARD	What If Simulation System for Aircraft Research and Development