

AD-A283 922

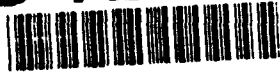

INSTRUCTION REPORT CERC-91-1

①

US Army Corps
of Engineers

COASTAL MODELING SYSTEM (CMS) USER'S MANUAL

by

Mary A. Cialone, David J. Mark, Lucia W. Chou, David A. Leenknecht,
Jack E. Davis, Linda S. Lillycrop, Robert E. Jensen,
Edward F. Thompson, Mark B. Gravens, Julie D. Rosati,
Randall A. Wise, Nicholas C. Kraus, P. Magnus Larson, Jane M. Smith

DEPARTMENT OF THE ARMY
Waterways Experiment Station, Corps of Engineers
3909 Halls Ferry Road, Vicksburg, Mississippi 39180-6199

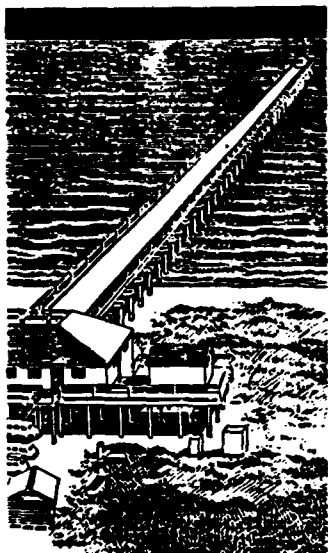

DTIC
ELECTE
AUG 29 1994
S B D

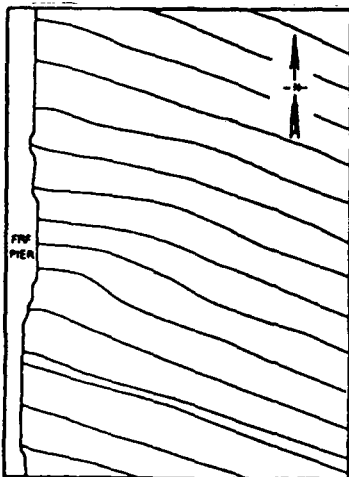

WAVE REFRACTION DIAGRAM
PERIOD 8 SECONDS ANGLE 35 DEGREES

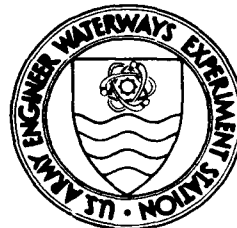

August 1994

Supplement 3 to September 1991 Manual

Approved For Public Release; Distribution Is Unlimited

2000

94-27592



037050



Prepared for DEPARTMENT OF THE ARMY
US Army Corps of Engineers
Washington, DC 20314-1000

Under Work Unit 31675

94 8 26

137

**Destroy this report when no longer needed. Do not return
it to the originator.**

**The findings in this report are not to be construed as an official
Department of the Army position unless so designated
by other authorized documents.**

This user's manual is furnished by the Government and is accepted and used by the recipient with the express understanding that the United States Government makes no warranties, expressed or implied, concerning the accuracy, completeness, reliability, usability, or suitability for any particular purpose of the information and data contained in this manual or furnished in connection therewith, and the United States shall be under no liability whatsoever to any person by reason of any use made thereof. The manual belongs to the Government. Therefore, the recipient further agrees not to assert any proprietary right therein or to represent this manual to anyone as other than a Government manual.

**The contents of this report are not to be used for advertising,
publication, or promotional purposes. Citation of trade names
does not constitute an official endorsement or approval of the
use of such commercial products.**

THE COASTAL MODELING SYSTEM USER'S MANUAL
Supplement 3

Issued August 1994

Enclosed are additions and corrections to the *Coastal Modeling System (CMS) User's Manual*, which was originally published in September 1991 and sent to your office. If you do not have or cannot find the original publication, please contact Mary Cialone at (601) 634-2139 for another copy. Please note the following:

- a. Chapter 1 has been modified because model WICM was added to the CMS.
- b. Chapter 13, which documents model HURWIN, has been modified because the model was enhanced.
- c. Chapter 14, which documents model WICM, is an addition to the *CMS User's Manual*.

REPORT DOCUMENTATION PAGE

Form Approved
OMB No. 0704-0188

Public reporting burden for this collection of information is estimated to average 1 hour per response, including the time for reviewing instructions, searching existing data sources, gathering and maintaining the data needed, and completing and reviewing the collection of information. Send comments regarding this burden estimate or any other aspect of this collection of information, including suggestions for reducing this burden, to Washington Headquarters Services, Directorate for Information Operations and Reports, 1215 Jefferson Davis Highway, Suite 1204, Arlington, VA 22202-4302, and to the Office of Management and Budget, Paperwork Reduction Project (0704-0188), Washington, DC 20503.

1. AGENCY USE ONLY (Leave blank)	2. REPORT DATE August 1994	3. REPORT TYPE AND DATES COVERED Supplement 3 to September 1991 Manual	
4. TITLE AND SUBTITLE Coastal Modeling System (CMS) User's Manual		5. FUNDING NUMBERS WU 31675	
6. AUTHOR(S) See reverse		7. PERFORMING ORGANIZATION NAME(S) AND ADDRESS(ES) U.S. Army Engineer Waterways Experiment Station 3909 Halls Ferry Road, Vicksburg, MS 39180-6199	
9. SPONSORING / MONITORING AGENCY NAME(S) AND ADDRESS(ES) U.S. Army Corps of Engineers Washington, DC 20314-1000		8. PERFORMING ORGANIZATION REPORT NUMBER Instruction Report CERC-91-1	
11. SUPPLEMENTARY NOTES Available from National Technical Information Service, 5285 Port Royal Road, Springfield, VA 22161.			
12a. DISTRIBUTION / AVAILABILITY STATEMENT Approved for public release; distribution is unlimited		12b. DISTRIBUTION CODE	
13. ABSTRACT (Maximum 200 words) The Coastal Modeling System (CMS) is a software package aimed at organizing the Coastal Engineering Research Center's larger numerical models and their supporting software into a user-friendly system that is available to all Corps elements having a need to apply the supported modeling technology. Since some of the models share similar input requirements, output capability, and procedural implementation, efforts are made to standardize these portions of the models as much as possible. FORTRAN 77 programming language is used exclusively in the system software to ensure portability of the models and supporting programs to other computer systems. Graphics programs also make use of DISSPLA software. Models selected for inclusion in CMS are well advanced in their development and have been rigorously tested over a wide range of conditions. The models in CMS can be considered tested, reliable, and mature. The numerical models documented here include: SPH, WIFM, RCPWAVE, CLHYD, SHALWV, STWAVE, and HARBD. Numerical model SPH is a parametric model for representing wind and atmospheric pressure fields generated by hurricanes. Numerical model WIFM solves the vertically integrated Navier-Stokes equations in stretched Cartesian coordinates. The model simulates shallow-water, long-wave hydrodynamics such as tidal circulation, storm surges, and tsunami propagation. Numerical model			
14. SUBJECT TERMS See reverse		<i>(Continued)</i>	
17. SECURITY CLASSIFICATION OF REPORT UNCLASSIFIED		15. NUMBER OF PAGES 201	
18. SECURITY CLASSIFICATION OF THIS PAGE UNCLASSIFIED		16. PRICE CODE	
19. SECURITY CLASSIFICATION OF ABSTRACT		20. LIMITATION OF ABSTRACT	

6. (Concluded).

Mary A. Cialone, David J. Mark, Lucia W. Chou, David A. Leenknecht, Jack E. Davis, Linda S. Lillycrop, Robert E. Jensen, Edward F. Thompson, Mark B. Gravens, Julie D. Rosati, Randall A. Wise, Nicholas C. Kraus, P. Magnus Larson, Jane M. Smith

13. (Concluded).

RCPWAVE is a short-wave model used to predict linear, plane wave propagation over an open coast region of arbitrary bathymetry. Numerical model CLHYD simulates shallow-water, long-wave hydrodynamics such as tidal circulation and storm surge propagation. CLHYD can simulate flow fields induced by wind fields, river inflows/outflows, and tidal forcing. Numerical model SHALWV is a time-dependent spectral wind-wave model for computing a time-history of wind-generated waves. STWAVE is a computationally efficient finite-difference model for near-coast time-independent spectral wave energy propagation simulations. HARBD is a harbor wave oscillation model for use in the design and modification of harbors. Numerical model GENESIS is a collection of generalized computer programs in a single menu-driven module that enables complete design level shoreline evolution investigations to be performed by field engineers from within the CMS on the CRAY Y-MP supercomputer. SBEACH simulates beach profile change, including the formation and movement of major morphologic features such as longshore bars, troughs, and berms, under varying storm waves and water levels. PBLWIND is a generalized numerical model used to predict winds near the water surface based on atmospheric pressure gradients and temperature differences between the air and water. Numerical model HURWIN measures surface stress and wind speed and direction in the planetary boundary layer of a tropical cyclone. WICM is a two-dimensional, depth-averaged model for computing wave-induced currents and water surface setup.

14. (Concluded).

CLHYD
CMS
Coastal Modeling System (CMS)
GENESIS
HARBD

HURWIN
PBLWIND
RCPWAVE
SBEACH
SHALWV

SPH
STWAVE
WICM
WIFM

Accession For

RTIS GRA&I

DTIC TAB

Unannounced

Justification

By _____

Distribution/

Availability Codes

Dist Avail and/or Special

AM

PREFACE

This manual presents the documentation for eleven numerical models and supporting software that comprise the Coastal Modeling System. The system developed documented here was authorized as part of the Civil Works Research and Development Program of Headquarters, U.S. Army Corps of Engineers (HQUSACE). This work was funded under Work Unit 31675, "Development of a Coastal Modeling System," which is part of the Harbor Entrances and Coastal Channels Program. Messrs. John H. Lockhart, Jr.; John G. Housley; Barry W. Holliday; and John Sanda were the HQUSACE Technical Monitors. Ms. Carolyn M. Holmes was the CERC Program Manager.

The system development was conducted under the direction of Dr. James R. Houston, Director, Coastal Engineering Research Center (CERC) of the U.S. Army Engineer Waterways Experiment Station (WES); Mr. Charles C. Calhoun, Jr., Assistant Director, CERC; Mr. H. Lee Butler, Chief, Research Division (RD); and Mr. Bruce A. Ebersole, Chief, Coastal Processes Branch (CPB). Technical Editor for the *Coastal Modeling System User's Manual* was Ms. Mary A. Cialone, CPB, RD. The various chapters of the manual were authored by the following individuals:

Chapter 1	Mary A. Cialone
Chapter 2	Mary A. Cialone and Lucia W. Chou, CPB, RD
Chapter 3	Mary A. Cialone and David J. Mark, CPB, RD
Chapter 4	Mary A. Cialone
Chapter 5	Mary A. Cialone
Chapter 6	Mary A. Cialone
Chapter 7	Jack E. Davis, Coastal Oceanography Branch (COB), RD, and Robert E. Jensen, COB, RD
Chapter 8	Jack E. Davis and Robert E. Jensen
Chapter 9	Linda S. Lillycrop, COB, RD
Chapter 10	Mark B. Gravens
Chapter 11	Julie D. Rosati, Randall A. Wise, Nicholas C. Kraus, P. Magnus Larson
Chapter 12	Edward F. Thompson
Chapter 13	Edward F. Thompson
Chapter 14	Mary A. Cialone and Jane M. Smith, CPB, RD
Appendix A	Mary A. Cialone, David J. Mark, and David A. Leenknecht, Automated Coastal Engineering (ACES) Group, RD
Appendix B	Mary A. Cialone, David J. Mark, and David A. Leenknecht
Appendix C	Mary A. Cialone and Lucia W. Chou
Appendix D	Mary A. Cialone and Lucia W. Chou

An extensive amount of word processing and figure preparation for this report were provided by Ms. Dawn E. Abbe, CPB, RD.

At the time of publication of this report, Director of WES was Dr. Robert W. Whalin. Commander was COL Bruce K. Howard, EN.

CONTENTS

	<u>Page</u>
PREFACE	i
CONVERSION FACTORS, NON-SI TO SI (METRIC) UNITS OF MEASUREMENT . . .	ix
CHAPTER 1: COASTAL MODELING SYSTEM (CMS) OVERVIEW	1-1
PART I: INTRODUCTION	1-1
Background	1-1
Objective	1-2
PART II: IMPLEMENTATION OF CMS	1-4
Organization	1-4
Host Computer System	1-4
Model Support	1-5
<i>Coastal Modeling System (CMS) User's Manual</i>	1-6
Point of Contact	1-6
PART III: PRESENT CMS COMPONENTS	1-8
Chapter 2: Using the Coastal Modeling System	1-8
Chapter 3: Standard Project Hurricane (SPH)	1-8
Chapter 4: WES Implicit Flooding Mode (WIFM)	1-8
Chapter 5: Regional Coastal Processes Wave Propagation Model (RCPWAVE)	1-9
Chapter 6: Curvilinear Long-Wave Hydrodynamic Model (CLHYD)	1-9
Chapter 7: Spectral Wave Modeling Module: Model SHALWV	1-9
Chapter 8: Spectral Wave Modeling Module: Model STWAVE	1-9
Chapter 9. Harbor Wave Oscillation Model (HARBD)	1-10
Chapter 10. Generalized Model for Simulating Shoreline Change (GENESIS)	1-10
Chapter 11. Storm-Induced Beach Change Model (SBEACH)	1-10
Chapter 12. Extratropical Storm Planetary Boundary Layer Wind Model (PBLWIND)	1-11
Chapter 13. Tropical Storm Planetary Boundary Layer Wind Model (HURWIN)	1-11
Chapter 14. Wave-Induced Current Model (WICM)	1-12
Appendix A: CMSGRID	1-12
Appendix B: CMSUTIL	1-12
Appendix C: CMSPOST	1-12
Appendix D: CMSSAMP	1-13
Reference	1-13
CHAPTER 2: USING THE COASTAL MODELING SYSTEM	2-1
PART I: ACCESS TO THE VAX 8800 AND CRAY Y-MP	2-1
Introduction	2-1
Computer Account Information	2-1
Login Procedure for the CRAY Y-MP	2-1
PART II: ACCESSING THE CMS	2-3

PART III: ILLUSTRATIONS OF THE CMS	2-6
Compilation	2-6
Execution	2-12
PART IV: CREATING AND EDITING INPUT FILES TO THE CMS	2-37
PART V: FILE TRANSFER PROCEDURE BETWEEN THE PC AND CRAY Y-MP	2-38
CHAPTER 3: STANDARD PROJECT HURRICANE (SPH) MODEL THEORY AND PROGRAM DOCUMENTATION	3-1
PART I: INTRODUCTION	3-1
PART II: COMPUTATIONAL TECHNIQUE	3-3
PART III: DETERMINATION OF HURRICANE PARAMETERS	3-12
Parameters for the SPH	3-12
Parameters for Historical Storms	3-21
PART IV: DISCUSSION OF INPUT DATA REQUIREMENTS	3-23
Model Control Specifications	3-23
Wind-Field Specification	3-29
Output Specification	3-32
PART VI: TEST PROBLEMS	3-38
Test Problem 1	3-41
Test Problem 2	3-50
REFERENCES	3-60
APPENDIX 3-A: SPH DATA SPECIFICATION RECORDS	3-61
CHAPTER 4: WES IMPLICIT FLOODING MODEL (WIFM) THEORY AND PROGRAM DOCUMENTATION	4-1
PART I: INTRODUCTION	4-1
PART II: SHALLOW-WATER WAVE EQUATION	4-3
Assumptions and Limitations	4-3
Governing Equations	4-4
Grid System	4-10
Computational Technique	4-12
Boundary Conditions	4-16
PART III: DEFINITION OF INPUT DATA FORMAT	4-19
PART IV: DISCUSSION OF INPUT DATA REQUIREMENTS	4-22
Model Control Specifications	4-22
Grid Description	4-26
Physical Characteristics	4-29
Boundary Conditions	4-37
Wind-Field Specifications	4-47
Output Specification	4-49

PART V:	ILLUSTRATIVE EXAMPLES	4-53
	Tidal Forcing Simulation	4-54
	Tidal Forcing Simulation with Nonlinear Terms	4-60
	Wind-Induced Setup Simulation	4-60
	River Discharge Simulation	4-71
	Storm Surge Example	4-77
	REFERENCES	4-85
	APPENDIX 4-A: WIFM DATA SPECIFICATION RECORDS	4-87
CHAPTER 5:	REGIONAL COASTAL PROCESSES WAVE PROPAGATION MODEL THEORY AND PROGRAM DOCUMENTATION	5-1
PART I:	INTRODUCTION	5-1
	Report Organization	5-2
PART II:	THEORETICAL DEVELOPMENT	5-3
	Assumptions and Limitations	5-3
	Governing Equations Outside the Surf Zone	5-3
PART III:	DEFINITION OF INPUT DATA FORMAT	5-18
PART IV:	DISCUSSION OF THE INPUT DATA REQUIREMENTS	5-21
	Model Control Parameters	5-21
	Grid Description	5-22
	Physical Characteristics	5-23
	Output Specifications	5-26
PART V:	ILLUSTRATIVE EXAMPLES	5-29
	Duck, North Carolina	5-29
	Homer Spit, Alaska	5-33
	REFERENCES	5-36
	APPENDIX 5-A: RCPWAVE DATA SPECIFICATION RECORDS	5-37
	APPENDIX 5-B: INPUT DATA SET FOR DUCK, NORTH CAROLINA	5-49
	APPENDIX 5-C: INPUT DATA SET FOR HOMER SPIT, ALASKA	5-59
CHAPTER 6:	CLHYD - A CURVILINEAR LONG WAVE HYDRODYNAMIC MODEL THEORY AND PROGRAM DOCUMENTATION	6-1
PART I:	INTRODUCTION	6-1
PART II:	CLHYD MODEL FORMULATION	6-2
	Assumptions and Limitations	6-2
	Governing Equations	6-3
	Grid Systems	6-8
	Governing Equations in General Curvilinear Coordinates	6-13
	Finite Difference Methods	6-14
	Computational Theory	6-20

PART III: DEFINITION OF INPUT DATA FORMAT	6-26
PART IV: DISCUSSION OF INPUT DATA REQUIREMENTS	6-29
Model Control Specifications	6-29
Grid Description	6-33
Physical Characteristics	6-35
Boundary Conditions	6-39
Wind-Field Specifications	6-48
Output Specification	6-50
PART V: ILLUSTRATIVE EXAMPLES	6-54
Tidal-Forcing Simulation	6-55
Tidal-Forcing Simulation with Nonlinear Terms	6-61
Wind-Induced Setup Simulation	6-61
River Discharge Simulation	6-72
Orthogonal Curvilinear Grid Test Series	6-78
Static Basin Tests	6-78
Wind-Induced Setup Tests	6-79
Tidal-Forcing Test	6-82
Grid Resolution Tests Using Orthogonal Curvilinear Grids	6-85
REFERENCES	6-114
APPENDIX 6-A: TRANSFORMATION OF ADVECTION AND DISPERSION TERMS	6-117
APPENDIX 6-B: CLHYD DATA SPECIFICATION RECORDS	6-123
APPENDIX 6-C: INPUT DATA SET FOR THE INDIAN RIVER INLET EXAMPLE	6-159
CHAPTER 7: SHALWV THEORY AND PROGRAM DOCUMENTATION	7-1
PART I: INTRODUCTION	7-1
PART II: DESCRIPTION OF THE SPECTRAL WAVE MODELING PROGRAMS	7-2
Theoretical Foundation	7-2
Advection Terms	7-3
Source Terms	7-4
Diffraction and Sheltering	7-6
Initial and Boundary Conditions	7-7
Preprocessing Options	7-8
Warm Starts	7-9
Computational Grids and Subgrids	7-10
Assumptions and Limitations of SHALWV	7-10
PART III: STRUCTURE OF THE SPECTRAL WAVE MODELING MODULE	7-14
Introduction	7-14
Operational Structure of the SHALWV Branch	7-14
PART IV: MODULE FUNCTIONS AND ROUTINES	7-20
SHALWV Module Functions and Routines	7-20
Input Descriptions	7-61

Function to Run Programs	7-71
Function to Plot/Print SHALWV Output	7-73
PART V: SPECTRAL WAVE MODELING MODULE FILE DESCRIPTIONS . . .	7-76
SHALWV Files	7-76
File Descriptions and Data Formats	7-76
Example Data Sets	7-94
REFERENCES	7-104
CHAPTER 8: STWAVE THEORY AND PROGRAM DOCUMENTATION	8-1
PART I: INTRODUCTIONS	8-1
Theoretical Foundation	8-1
Solution Method	8-3
PART II: STRUCTURE (THE SPECTRAL WAVE MODELING MODULE . . .	8-6
Introduction: Operational Structure of the	
STWAVE Branch	8-6
Organizational Procedures for Common Simulations	8-6
PART III: MODULE FUNCTIONS AND ROUTINES	8-11
STWAVE Module Functions and Routines	8-11
File-Building Functions	8-11
Function to Run Programs	8-32
Function to Plot/Print STWAVE Output	8-33
PART IV: SPECTRAL WAVE MODELING MODULE FILE DESCRIPTIONS . . .	8-34
STWAVE Files	8-34
File Descriptions and Data Formats	8-35
REFERENCES	8-44
CHAPTER 9: HARBOR WAVE OSCILLATION MODEL (HARBD) THEORY AND	
PROGRAM DOCUMENTATION	9-1
PART I: INTRODUCTION	9-1
Background	9-1
Report Organization	9-2
PART II: MATHEMATICAL FORMULATION	9-3
Assumptions and Limitations	9-3
Boundary Value Problem	9-3
Solution Method	9-9
Hybrid Element Solution Method	9-9
PART III: DEFINITION OF INPUT DATA FORMAT	9-14
PART IV: DISCUSSION OF THE INPUT DATA REQUIREMENTS	9-17
Model Control Specifications	9-17
Finite Element Grid Description	9-18
Physical Characteristics	9-23
Output Specifications	9-25

PART V: ILLUSTRATIVE EXAMPLES	9-28
Agat Harbor, Guam	9-28
Maalaea Harbor, Maui, Hawaii	9-32
REFERENCES	9-39
APPENDIX 9-A: HARBD FUNCTION INDEX	9-43
APPENDIX 9-B: INPUT DATA SET FOR FINITE ELEMENT GRID	9-57
APPENDIX 9-C: INPUT DATA SET FOR AGAT HARBOR, GUAM EXAMPLE	9-61
APPENDIX 9-D: OUTPUT LISTING FOR AGAT HARBOR, GUAM EXAMPLE	9-95
APPENDIX 9-E: INPUT DATA SET FOR MAALAEA HARBOR, MAUI, HAWAII EXAMPLE	9-111
APPENDIX 9-F: OUTPUT LISTING FOR MAALAEA HARBOR, MAUI, HAWAII EXAMPLE	9-117
CHAPTER 10: GENESIS: GENERALIZED MODEL FOR SIMULATING SHORELINE CHANGE	10-1
PART I: INTRODUCTION	10-1
GENESIS Module Contents	10-1
Chapter Overview	10-2
PART II: GENESIS MODULE STRUCTURE AND USE	10-3
Level 1 Menu: MAIN	10-3
Level 2 Menu: GENESIS SYSTEM	10-5
Level 2 Menu: GENESIS SYSTEM SUPPORT TOOLBOX	10-6
Level 3 Menu: PREPARATION OF SHORELINE DATA	10-7
Level 3 Menu: OFFSHORE WAVE DATA ANALYSIS	10-8
Level 3 Menu: NEARSHORE WAVE DATA ANALYSIS	10-9
PART III: ANALYSIS PROCEDURES	10-12
Shoreline Data Analysis	10-13
Analysis of Offshore Wave Data	10-15
Analysis of Nearshore Wave Data	10-17
PART IV: OVERVIEW OF GENESIS	10-23
GENESIS.	10-23
Calibration and Verification Procedures	10-26
Sensitivity Testing	10-28
Interpretation of Model Results	10-29
PART V: GENESIS MODULE GRAPHICS PROGRAMS	10-30
GENESIS Graphics	10-30
SSPGRAF	10-34
REFERENCES	10-41
APPENDIX 10-A: HYPOTHETICAL GENESIS INPUT AND OUTPUT DATA SET	10-43
CHAPTER 11: SBEACH: NUMERICAL MODEL FOR SIMULATING STORM-INDUCED BEACH CHANGE	11-1

PART I:	INTRODUCTION	11-1
	Overview of SBEACH	11-1
	Chapter Overview	11-4
PART II:	SBEACH INPUT DATA SET	11-5
	Overview	11-5
	Configuration File	11-6
	Profile, Wave, Water Elevation, and Wind Data Files	11-19
PART III:	THE CMS SBEACH MODULE	11-22
	MAIN MENU	11-23
	Level 1: Execute SBEACH Menu	11-25
	Level 1: SBEACH GRAPH MENU	11-28
	Level 2: Select Plot Type	11-33
	Level 2: Select Plotting Device	11-36
	Level 3: View Plot on Screen	11-38
PART IV:	EXAMPLE APPLICATIONS	11-41
	Example 1: Seawall Option	11-41
	Example 2: Schematized Profile	11-44
	Example 3: Beach Fill Option	11-49
	Obtaining Assistance, Updates, and Reporting Problems	11-51
PART V:	CALIBRATION AND VERIFICATION	11-52
	Overview	11-52
	Profile Data	11-52
	Grain Size Data	11-53
	Water Level Data	11-54
	Wave Data	11-55
	Wind Data	11-56
	Model Parameters	11-56
	Calibration Strategy	11-57
REFERENCES	11-58
CHAPTER 12: PBLWIND: GENERAL-PURPOSE PLANETARY BOUNDARY LAYER		
	WIND MODEL THEORY AND PROGRAM DOCUMENTATION	12-1
PART I:	INTRODUCTION	12-1
	Report Organization	12-1
PART II:	THEORETICAL DEVELOPMENT	12-2
	Assumptions and Limitations	12-2
	Geostrophic Wind	12-3
	Gradient Wind	12-5
	Planetary Boundary Layer Wind	12-6
	Special Cases in PBL Calculation	12-11
PART III:	DEFINITION OF INPUT DATA FORMAT	12-13
PART IV:	DISCUSSION OF THE INPUT DATA REQUIREMENTS	12-16
	Model Control Specifications	12-16
	Grid Description	12-18

Physical Characteristics	12-22
Pressure Field Specifications	12-23
Temperature Field Specifications	12-23
Output Specifications	12-24
Input and Output File Names	12-26
PART V: ILLUSTRATIVE EXAMPLES	12-27
REFERENCES	12-37
APPENDIX 12-A: PBLWIND RECORD FUNCTION INDEX	12-39
APPENDIX 12-B: IDEALIZED PRESSURE FIELD EXAMPLE	12-61
APPENDIX 12-C: NORTH ATLANTIC OCEAN EXAMPLE	12-67
CHAPTER 13: HURWIN: TROPICAL STORM PLANETARY BOUNDARY LAYER	
WIND MODEL	13-1
PART I: INTRODUCTION	13-1
PART II: THEORETICAL FOUNDATION	13-3
Overview	13-3
Terrain Transformation Model	13-13
PART III: GENERAL STRUCTURE OF HURWIN	13-17
PART IV: HURWIN MODULE FUNCTIONS AND ROUTINES	13-24
File-Building Function	13-24
Run Programs Function	13-41
PART V: HURWIN FILE DESCRIPTIONS	13-43
Introduction	13-43
File Descriptions and Data Formats	13-43
PART VI: EXAMPLE APPLICATION	13-53
REFERENCES	13-59
CHAPTER 14: WICM: A WAVE-INDUCED CURRENT MODEL THEORY AND	
PROGRAM DOCUMENTATION	14-1
PART I: INTRODUCTION	14-1
PART II: WICM MODEL FORMULATION	14-2
Assumptions and Limitations	14-2
Governing Equations	14-3
Grid Systems	14-8
Governing Equations in General Curvilinear	
Coordinates	14-14
Computational Theory	14-20
Boundary Conditions	14-22
PART III: DEFINITION OF INPUT DATA FORMAT	14-26

PART IV:	DISCUSSION OF INPUT DATA REQUIREMENTS	14-29
	Model Control Specifications	14-29
	Grid Description	14-33
	Physical Characteristics	14-35
	Boundary Conditions	14-39
	Wind-Field Specifications	14-47
	Wave Field Specifications	14-50
	Output Specification	14-51
PART V:	ILLUSTRATIVE EXAMPLES	14-55
	Plane Beach Simulation	14-55
	Leadbetter Beach, CA, Simulation with RCPWAVE	14-59
	Leadbetter Beach, CA, Simulation with STWAVE	14-62
APPENDIX 14-A:	TRANSFORMATION OF ADVECTION AND DIFFUSION TERMS.	14-66
APPENDIX 14-B:	WICM DATA SPECIFICATION RECORDS	14-72
APPENDIX 14-C:	INPUT DATA SET FOR THE INDIAN RIVER INLET EXAMPLE	14-109
APPENDIX A:	CMSGRID	A-1
	Introduction	A-2
	Computational Technique of Program MAPIT	A-3
	Generating Stretch Rectilinear Grids	A-9
	Program MAPIT	A-14
	Program DRAWIT	A-25
	Program LISTIT	A-34
	Reference	A-38
APPENDIX B:	CMSUTIL	B-1
	Introduction	B-2
	Program TIDEGEN	B-2
APPENDIX C:	CMSPOST	C-1
	Introduction	C-2
	Data Requirements	C-2
	Program HYDPLT	C-13
	Program HYDLST	C-21
	Program HYDADD	C-27
	Program SNAPVEC	C-32
	Program SNAPLST	C-38
	Program RAYPLT	C-43
	Program PROFPLT	C-50
APPENDIX D:	CMSSAMP	D-1
	Introduction	D-2

CONVERSION FACTORS, NON-SI TO SI (METRIC)
UNITS OF MEASUREMENT

Non-SI units of measurement used in this report can be converted to SI (metric) units as follows:

<u>Multiply</u>	<u>By</u>	<u>To Obtain</u>
acres	4,046.873	square meters
cubic feet	0.02831685	cubic meters
cubic yards	0.7645549	cubic meters
degrees (angle)	0.01745329	radians
fathoms	1.8288	meters
feet	0.3048	meters
inches	25.4	millimeters
knots (international)	0.5144444	meters per second
miles (US nautical)	1.852	kilometers
miles (US statute)	1.609347	kilometers
pounds (force) per square inch	6.894757	kilopascals

COASTAL MODELING SYSTEM (CMS) USER'S MANUAL

CHAPTER 1

COASTAL MODELING SYSTEM (CMS) OVERVIEW

PART I: INTRODUCTION

Background

1. Numerical modeling technology is increasingly being employed as a tool to study complex problems in many engineering disciplines. In the field of coastal engineering, processes studied with numerical models include: hydrodynamics and transport associated with astronomical tides, storm surges, and tsunamis; refraction, diffraction, shoaling and breaking of waves; wave-induced currents; shoreline change induced by littoral movement of sand; erosion caused by short-term severe storms; and the fate and stability of dredged material placed in open water.

2. Numerical models use sophisticated methodology to solve governing equations describing the physical processes of interest. When a physical process is well described by the specified equations, the numerical modeling technique is capable of providing accurate solutions to engineering problems. However, the model developer must take extreme care in implementing the equations in a numerical scheme, and the model must be thoroughly tested for a variety of conditions and compared with prototype measurements to ensure correct model operation. Of equal importance is the care the engineer must take in applying the model to a field problem by ensuring that the model's governing equations are appropriate for representing the dominant physical processes at the site. Also, errors in input specification could dramatically alter model results, and without diligent inspection of model output, the errors could go undetected.

3. The Coastal Engineering Research Center (CERC) has developed a number of numerical models that are used for studying a variety of coastal processes under existing and proposed configurations. Some of these models are large and complex and may require a substantial amount of input data and/or computing effort. The models usually have a battery of supporting software for creating computational grids, running the model on the host

computer, and evaluating large amounts of output from the simulations. Because of the complexity of the model software and the diversity of modifications to input data associated with individual applications, these models have required considerable effort to apply.

4. Traditionally, most of the models were developed by researchers as individual efforts to solve a specific problem. Consequently, models have used different input/output structures, have been sparsely documented, and have been frequently altered to accomplish application-specific tasks. In addition, each model had its own set of supporting utilities to plot results, reformat data, etc. Often code alterations resulted in several versions of the same model, each with specific or enhanced capabilities. This situation had the potential for introducing errors, either by engineers applying the wrong version of the model or by programmers inadvertently altering the operation of a previously tested portion of the model.

5. Because of these factors, some of the most useful models at CERC have also been the most difficult to apply; and in some cases, it was necessary for the model developer to oversee the specific application. This dependence on the model developer meant that he or she had less time to devote to providing improved models to solve Corps problems.

6. The condition of the models described above implied a need for:

- a. Maintenance of a single version of each model.
- b. Standardization of the model input/output processes.
- c. A central location for using the models.
- d. Versatile models capable of covering a wide range of problems at different sites by using model options.
- e. Comprehensive model documentation in the form of a user's manual.

Objective

7. The Coastal Modeling System (CMS) is a software package aimed at organizing CERC's larger numerical models and their supporting software into a user-friendly system that is available to all Corps elements having a need to apply the supported modeling technology.

8. Several objectives are followed in developing and expanding CMS. Since some of the models share similar input requirements, output capability,

and procedural implementation, efforts are made to standardize these portions of the models as much as possible. This standardization promotes efficiency because coding effort is reduced, new users learn the models in the system more rapidly, and chances for errors in entering input or interpreting output are reduced because of user familiarity with the system structure.

9. Most numerical models are applied to specific areas by representing the spatial bathymetric and topographic features as depths or elevations on a matrix called a computational grid. In some instances, it is possible to share a common numerical grid between models. This commonality allows efficient application of several different models to the same site without additional effort in building new grids. Similarly, processing of model output data can proceed in the same manner for several different models. To the extent possible, models in CMS share the same numerical grids, utilities, plotting programs, post-processing routines, and job control files.

10. FORTRAN 77 programming language is used exclusively in the system software to ensure portability of the models and supporting programs to other computer systems. Graphics programs also make use of DISSPLA™ software. When appropriate, attempts are made to produce a code that is capable of being vectorized for efficient and economical use on vector array processing computers such as the CRAY Y-MP, where CMS resides.

11. Models selected for inclusion in CMS must be well advanced in their development, and they must have been rigorously tested over a wide range of conditions. In most cases, a selected model has already been applied to numerous field problems and, thus, has reached some level of maturity through careful application to the types of problems encountered by the Corps. Incorporation of these time-tested models into CMS involves modification to the input/output structure and, possibly, re-coding of sections to produce more efficient use of computer resources. Once included in CMS, the models are not expected to be modified unless errors are found or new features are added. Therefore, the models in CMS can be considered tested, reliable, and mature.

PART II: IMPLEMENTATION OF CMS

Organization

12. CMS software is organized into three major groups: models, supporting utilities, and procedure files that draw components together for execution. Several software elements use common algorithms, and efforts are made to place these software elements into shared libraries. This placement eliminates redundant software and reduces associated development costs.

13. Another level of organization concerns user interfaces to the software, which are arranged according to various activities encountered during a modeling endeavor. These major procedure files provide users access to the various CMS software elements on the available computers.

14. Although the models and supporting software are written in standard FORTRAN 77, library structures and procedure files are specific to the computer system hosting CMS. In addition, some plotting utilities rely on specific graphics software that resides on the host computer, and certain terminal/plotter configurations may be required to produce plots of the model output at the user's local site.

Host Computer System

15. Most models included in CMS, or targeted for addition to CMS, are both memory-intensive and computationally intensive, requiring use of large supercomputers for efficient operation. It is possible to run some of the models on smaller minicomputers, but double precision would probably be necessary to avoid accumulated round-off errors, and applications could take from several hours to several days of CPU time on the smaller machines.

16. To satisfy the objective of Corps-wide access to the models, initial installation of CMS was on a mainframe computer operated by Scientific Information Services (SIS), formerly CYBERNET, which provided Corps-wide mainframe and supercomputer service. Now, with the installation of a CRAY Y-MP at the US Army Engineer Waterways Experiment Station (WES), Corps-wide access is available, and CMS has been transferred to that system to take advantage of reduced costs and the likelihood of a permanent home for CMS.

17. Corps personnel have access to the CRAY Y-MP through several communication networks. Presently, the supercomputer can be accessed through INTERNET, MILNET, ARPANET, ASNET, SURANET, BITNET, NSFNET, through a 1200, 2400, or 9600 baud modem or a dedicated line.

18. Generally, CMS users are not required to learn the operating system associated with the supercomputer (UNICOS) because most of the job control commands normally required to submit models and data files to the computer for execution are accomplished by the CMS procedure files. This setup reduces learning time appreciably and minimizes errors caused by improper commands. However, users must be able to manipulate files, create and edit ASCII files, and download output files to a printer or plotter. These functions are easily mastered, and manuals are available to all Corps users of the CRAY Y-MP at a nominal fee by contacting the Information Technology Laboratory (ITL) Research Library, Ms. Susan Hicks (601) 634-2296. Presently there are 26 CRAY manuals covering such topics as UNICOS User Commands, CF77 Reference, UNICOS Support Tools, and UNICOS Symbolic Debugging.

Model Support

19. Including a model in CMS represents a technology transfer from CERC to the field. CERC will maintain the CMS on the WES CRAY Y-MP and will provide support services to Corps users of the system. Support includes correcting recognized flaws in the codes, updating the models with new capabilities and technology, improving the user interface to the models, improving graphics and visualization capabilities, updating the *User's Manual* to reflect changes to the models and/or CMS, conducting periodic workshops for Corps personnel, and providing telephone support services.

20. Additionally, CERC staff can assist Corps personnel in applications of the CMS via "one-stop services" or by direct participation in site-specific studies. One-stop service is intended to address questions or problems that arise during field application of a model in CMS. Usually, these questions can be satisfactorily resolved in a short time over the telephone. More involved questions requiring a substantial effort by CERC engineers or scientists may require reimbursement. Experience at CERC indicates that field application of these models usually requires a significant initial consulting effort by CERC engineers until experience has been gained by the field user.

Coastal Modeling System (CMS) User's Manual

21. The *Coastal Modeling System (CMS) User's Manual* is intended to be an evolving document, and it is structured in a modular fashion, much like the modeling system itself. Individual numerical models and major supporting utility software are documented in separate chapters. Attempts are made to structure all chapters in a similar format to facilitate learning the system models.

22. The unbound format of the user's manual allows efficient and cost-effective updating of the manual as models are added to CMS, and it allows users to remove chapters for convenient reference during model applications. The documentation for each new model will be an added chapter to the *CMS User's Manual*. Updates will also include additions of (or alterations to) utilities and procedures.

23. Initial distribution of the *CMS User's Manual* will be to all Corps Divisions and Districts with coastal interests. A register of all manuals distributed within the Corps of Engineers will be maintained by CERC, and updates will be provided for all Corps-registered copies of the manual.

24. Training on the usage of CMS and on application of specific models within CMS is accomplished during periodic workshops. Workshop participants, especially new users, will be introduced to CMS. Each workshop will demonstrate sign-on procedures, building input data files, file transfer methods, accessing CMS, running workshop-specific models, and post-processing model results. Technical presentations of workshop specific models will also be given. More intensive training can be provided at CERC as part of joint field applications between CERC and personnel from a field activity.

Point of Contact

25. Each model residing in CMS has a CERC point of contact (POC). Most often that person is the model developer or someone with extensive experience in applying the model. Table 1-1 provides POC's for models presently included in CMS. This table will be updated periodically to assure that it continues to be a useful reference for CMS users. The modules listed in column 1 of Table 1-1 are briefly described in Part III of this chapter and are extensively documented in later chapters.

Table 1-1
CERC Points of Contact

<u>Subject</u>	<u>Point of Contact</u>	<u>Office Symbol</u>	<u>Phone Number</u>
CMS general inquiries	Ms. Mary A. Cialone	CEWES-CR-P	601-634-2139
Using CMS	Ms. Lucy W. Chou	CEWES-CR-P	601-634-2843
SPH	Mr. Dave J. Mark	CEWES-CR-O	601-634-2094
WIFM	Ms. Mary A. Cialone	CEWES-CR-P	601-634-2139
RCPWAVE	Mr. Steven M. Bratos	CEWES-CR-O	601-634-4230
CLHYD	Ms. Mary A. Cialone	CEWES-CR-P	601-634-2139
SHALWV	Dr. Robert E. Jensen	CEWES-CR	601-634-2101
STWAVE	Mr. Steven M. Bratos	CEWES-CR-O	601-634-4230
HARBD	Dr. Edward F. Thompson	CEWES-CR-O	601-634-2027
GENESIS	Mr. Mark B. Gravens	CEWES-CR-P	601-634-3809
SBEACH	Mr. Randall A. Wise	CEWES-CR-P	601-634-3085
PBLWIND	Dr. Edward F. Thompson	CEWES-CR-O	601-634-2027
HURWIN	Dr. Edward F. Thompson	CEWES-CR-O	601-634-2027
WICM	Ms. Jane M. Smith	CEWES-CR-P	601-634-2079
CMSGRID	Ms. Mary A. Cialone	CEWES-CR-P	601-634-2139
CMSUTIL	Ms. Lucy W. Chou	CEWES-CR-P	601-634-2843
CMSPOST	Ms. Lucy W. Chou	CEWES-CR-P	601-634-2843
CMSSAMP	Ms. Lucy W. Chou	CEWES-CR-P	601-634-2843

PART III: PRESENT CMS COMPONENTS

26. The following briefly describes the numerical models, major utility software, and major procedures currently in the Coastal Modeling System.

Chapter 2: Using the Coastal Modeling System

27. This chapter provides information on execution of the CMS on the WES CRAY Y-MP. The new user should refer to this chapter to learn to compile or run a model for a specific application. Once the user becomes familiar with the system, this chapter can be used as a quick reference.

Chapter 3: Standard Project Hurricane (SPH)

28. The numerical model SPH is a parametric model for representing wind and atmospheric pressure fields generated by hurricanes. It is based on the Standard Project Hurricane criteria developed by the National Oceanic and Atmospheric Administration (NOAA 1979), and the model's primary output is hurricane-generated wind fields that can be used in storm surge modeling. It can be run separately, or it can be invoked from within the WES Implicit Flooding Model (WIFM).

Chapter 4: WES Implicit Flooding Model (WIFM)

29. The numerical model WIFM solves the vertically integrated Navier-Stokes equations in stretched Cartesian coordinates. The model simulates shallow-water, long-wave hydrodynamics such as tidal circulation, storm surges, and tsunami propagation. WIFM contains many useful features for studying these phenomena, such as moving boundaries to simulate flooding/drying of low-lying areas and subgrid flow boundaries to simulate small barrier islands, jetties, dunes, or other structural features. The model may be driven at the outer boundary by tide elevations, flow velocities, specification of uniform flux, or inverted barometer effects. WIFM also accepts wind fields for including the effects of wind stress during hurricanes or other strong storm systems.

Chapter 5: Regional Coastal Processes Wave Propagation Model (RCPWAVE)

30. The numerical model RCPWAVE is a short-wave model used to predict linear, plane wave propagation over an open coast region of arbitrary bathymetry. RCPWAVE uses linear wave theory because it has been shown to yield fairly accurate first-order solutions to wave propagation problems at a relatively low cost. Refractive and bottom-induced diffractive effects are included in the model; however, the model cannot treat diffraction caused by surface-piercing structures. This model does not include nonlinear wave effects or a spectral representation of irregular waves.

Chapter 6: Curvilinear Long-Wave Hydrodynamic Model (CLHYD)

31. The numerical model CLHYD simulates shallow-water, long-wave hydrodynamics such as tidal circulation and storm surge propagation. CLHYD can simulate flow fields induced by wind fields, river inflows/outflows, and tidal forcing. CLHYD is similar to WIFM, with the added feature of operating on a boundary-fitted (curvilinear) grid system. However, CLHYD cannot simulate flooding/drying of low-lying areas as WIFM can. This feature will be incorporated in a later release of CLHYD.

Chapter 7: Spectral Wave Modeling Module: Model SHALWV

32. The numerical model SHALWV is a time-dependent spectral wind-wave model for computing a time-history of wind-generated waves. The model solves the inhomogeneous energy balance equation using finite-difference methods. It simulates the growth, decay, and transformation of a wave field over a spatial area (i.e., an ocean basin, bay, or lake) for a given time period. SHALWV can simulate the wave climate for a specific storm or idealized events, such as a standard project hurricane.

Chapter 8: Spectral Wave Modeling Module: Model STWAVE

33. The numerical model STWAVE is a near-coast, time-independent spectral wave energy propagation model. The model solves the spectral energy balance equation (including refraction, shoaling, and wave breaking) using

finite-difference methods. This steady-state model simulates wave propagation over a spatial area assuming wave conditions vary sufficiently slowly. The variation of waves at a given point may be neglected relative to the time required for waves to pass across the computational grid if the model is limited to near-coast applications in which waves move quickly across the grid (within 30 minutes).

Chapter 9: Harbor Wave Oscillation Model (HARBD)

34. The numerical model HARBD is a finite element model for predicting wave oscillations in harbors. HARBD is a steady-state, linear monochromatic wave model that assumes bathymetric gradients are small and neglects wave-wave interaction, wave-current interaction, wave breaking, and wave transmission and overtopping of structures. The model has been used in the design and modification of numerous harbors, the study of dredging effects on wave propagation, and in the design and planning of wave protection structures for existing harbors.

Chapter 10: Generalized Model for Simulating Shoreline Change (GENESIS)

35. The numerical model GENESIS is a one-dimensional ("one-line") model for simulating long-term shoreline change. It can predict shoreline change and longshore transport rates under a wide range of beach, coastal structure, wave, initial and boundary conditions, which may vary in space and time. Input data include the initial shoreline position, measured shoreline position for calibration purposes, structure positions, depths along the nearshore reference line (where input from a wave model are saved), and the wave height, period, and direction for every time-step. Model output includes the shoreline position and longshore transport rates at user-specified time-steps.

Chapter 11: Storm-Induced Beach Change Model (SBEACH)

36. The numerical model SBEACH is an empirically-based two-dimensional model for predicting short-term, storm-induced beach erosion and post-storm recovery. Short-term erosion is treated as a process dominated by cross-shore

sand transport processes. Input requirements include a time-series of wave height and period, a time-series of water level, median beach grain size, and initial profile shape. Optionally, model input may include the presence of a seawall or revetment, and SBEACH simulates the profile response to such a structure. Model output includes the beach profile at all user-specified time-steps, as well as the cross-shore distribution of various process parameters (maximum wave height and water level, and wave height and water level at user-specified intervals).

Chapter 12: Extratropical Storm Planetary Boundary Layer Wind Model (PBLWIND)

37. The numerical model PBLWIND is a generalized numerical model used to predict winds near the water surface based on atmospheric pressure gradients and temperature differences between the air and water. PBLWIND is a steady state model which includes computational modules for geostrophic, gradient, and surface boundary layer winds. The model should not be used for modeling of hurricanes and tropical storms because their compact size, intense pressure gradients, and rapid changes in time require special treatment. Output from PBLWIND consists of wind speed and direction at a desired elevation above the water surface which can be used as input to a hydrodynamic model (SHALWV, WIFM, CLHYD).

Chapter 13: Tropical Storm Planetary Boundary Layer Wind Model (HURWIN)

38. The numerical model HURWIN is a two-dimensional, time-dependent model for predicting surface stress and wind speed and direction in the planetary boundary layer of a tropical cyclone. Wind information is calculated from meteorological storm parameters available for historical hurricanes and provided at a user-specified elevation. The model is based on the momentum equations that are vertically-averaged through the depth of the planetary boundary layer. Options are also provided for estimating surface wind over terrain of specified roughness including lakes, marshes, plains, woods, and cities. It has been used extensively in the Wave Information Studies (WIS) to hindcast historical hurricanes along U.S. coasts.

Chapter 14: Wave-Induced Current Model (WICM)

39. The numerical model WICM is a two-dimensional, depth-averaged model for predicting wave-induced currents and water surface setup. WICM can simulate flow fields induced by waves, winds, river inflows/outflows, and tidal forcing. Similar to CLHYD, this finite difference model is developed in boundary-fitted (curvilinear) coordinates and cannot simulate flooding and drying of low-lying areas.

Appendix A: CMSGRID

40. Grid development is a major part of successfully applying a numerical model to a specific site. Module CMSGRID contains software used in the generation of stretched coordinate, rectilinear computational grids for several models in CMS. The software employs sophisticated techniques that allow concentration of grid cells in regions of interest, or where geographic features are irregular, and wider spacing of grid cells in areas where conditions are not expected to change rapidly. The ability to generate variably spaced grids provides economy in computational time and costs. Generated grids can be plotted to scale on Mylar for overlaying bathymetric charts to obtain depths and elevations.

Appendix B: CMSUTIL

41. Module CMSUTIL contains useful programs that supplement numerical models in CMS. Presently, there are two programs in this module: a program to determine tidal constituents from a time-history of tidal elevations, and a program to generate a time series of water elevations from tidal constituent input.

Appendix C: CMSPOST

42. Most numerical models generate large output files containing results saved at user-specified grid cells and time-steps during the simulation. Module CMSPOST contains post-processing plotting packages that plot the model output for comparison and analysis purposes. Four basic types of

plotting are available: (a) time-histories of field arrays such as water surface elevation or velocity at selected grid points, (b) "snapshots" of the entire flow field at a given instant in time, (c) wave ray plots, and (d) profile plots that show the spatial variation of a model variable at an instant in time.

Appendix D: CMSSAMP

43. Module CMSSAMP is used to access sample input files for each of the models in the CMS. This provides the user with the required format of input data, and can also be used as a template for generating the user's own input file(s). In addition, sample files can be used to run a particular model in the CMS to help the user gain familiarity with the model. Appendix D contains a table of sample input file names and the procedure for accessing these files from within the CMS.

REFERENCE

National Oceanic and Atmospheric Administration. 1979. "Meteorological Criteria for Standard Project Hurricane and Probable Maximum Hurricane Wind Fields, Gulf and East Coasts of the United States," Technical Report NWS 23, National Weather Service, Washington, DC.

CHAPTER 13

HURWIN: TROPICAL STORM PLANETARY BOUNDARY LAYER WIND MODEL

PART I: INTRODUCTION

1. The HURWIN model in the Spectral Wave Modeling Module of the Coastal Modeling System (CMS) computes surface stress and wind speed and direction in the planetary boundary layer of a tropical cyclone. Wind information is calculated from meteorological storm parameters available for historical hurricanes and provided at a user-specified elevation. The full time history of the surface wind field is described by linear interpolation in time using a series of characteristic wind field "snapshots." Snapshots are calculated at discrete times in a storm's history, assuming the storm can be represented as a series of steady-state configurations.

2. The model, developed by Cardone, Greenwood, and Greenwood (1992) and upgraded by Cardone et al. (1994), is based on a numerical primitive equation model of the planetary boundary layer in a moving tropical cyclone. A surface drag formulation, based on Arya's (1977) similarity model, is coupled with a roughness parameter specification for a water surface consistent with Cardone's (1969) law. Options are also provided for estimating surface wind over terrain of specified roughness including lakes, marshes, plains, woods, and cities.

3. The CMS includes another hurricane wind model, the Standard Project Hurricane (SPH, Chapter 3). Although the SPH model and the HURWIN model provide similar information, the SPH model has traditionally been used in the Corps of Engineers (CE) as input to storm surge models (e.g. CLHYD, Chapter 6) and the HURWIN model with wave models (SHALWV, Chapter 7). The HURWIN model is more flexible and more nearly represents the physical processes in a hurricane. It has been used extensively in the Wave Information Studies (WIS) to hindcast historical hurricanes along U.S. coasts (Abel et al. 1989). The CMS will allow the two models to be more easily evaluated and compared in various applications. A broad overview of wind processes and CE modeling applications is given by Thompson and Leenknecht (1994).

4. Theoretical background of HURWIN is described in the following section. Operation of the HURWIN portion of the CMS Spectral Wave Modeling module is described in the remaining sections. The structure of the module is

described in Part III. Organizational procedures for a HURWIN simulation are described in Part IV. Part V covers the required data for a successful HURWIN simulation. An example problem, simulation of winds in Typhoon Russ, is presented in Part VI to illustrate application of the model.

PART II: THEORETICAL FOUNDATION

Overview

5. The basic model is based on a vortex model developed by Chow (1971) and modified by Cardone, Greenwood, and Greenwood (1992). The basic model was further modified by Cardone et al. (1994) to include options for more detailed spatial resolution and more general specification of radial pressure variation. Chow's model concerns the planetary boundary layer (PBL) only and solves for the wind field and horizontal convergence in the PBL of a moving tropical cyclone from the equations of motion. The pressure field in the boundary layer is prescribed and fixed, so that there are no atmospheric gravity waves excited in the numerical solution. This facilitates the use of a nested grid system, which allows grid spacings as small as 2 km near the hurricane inner region without sacrifice of overall computational efficiency.

6. The model is based upon the equation of horizontal motion, vertically averaged through the depth of the PBL, written in coordinates fixed to the earth as:

$$\frac{d\hat{V}}{dt} + f\vec{K} \times \hat{V} = -\frac{1}{\rho} \nabla p + \nabla \cdot (K_H \nabla \hat{V}) - \frac{C_D}{h} |\hat{V}| \hat{V} \quad (13-1)$$

where

$$\frac{d}{dt} = \frac{\partial}{\partial t} + \hat{V} \cdot \nabla$$

$\frac{\partial}{\partial t}$ - time change local to the fixed coordinates

\wedge - fixed coordinates

\hat{V} - vertically averaged horizontal velocity

∇ - two-dimensional del operator

f - Coriolis parameter

\vec{K} - unit vector in the vertical direction

ρ - mean air density

p - pressure

K_H - horizontal eddy viscosity coefficient

C_D - drag coefficient

h - depth of the planetary boundary layer

It is assumed that the vertical advection of momentum is small compared to the horizontal advection and can be neglected and that the shearing stress vanishes at the top of the PBL.

7. Pressure is prescribed as the sum of p_c and \bar{p}

$$p = p_c + \bar{p} \quad (13-2)$$

where

p_c - pressure field representing the tropical cyclone; not necessarily axisymmetric; assumed to translate with the storm at a specified velocity \hat{v}_c

\bar{p} - large-scale pressure field, which may be specified by the corresponding constant geostrophic flow \hat{v}_g as

$$f\vec{K} \times \hat{v}_g = -\frac{1}{\rho} \nabla \bar{p} \quad (13-3)$$

With this pressure specification, Equation 13-1 may be rewritten as follows:

$$\frac{d\hat{v}}{dt} + f\vec{K} \times (\hat{v} - \hat{v}_g) = -\frac{1}{\rho} \nabla p_c + \nabla \cdot (\kappa_H \nabla \hat{v}) - \frac{C_D}{h} |\hat{v}| \hat{v} \quad (13-4)$$

A moving Cartesian coordinate system (x, y) is now defined such that its origin always coincides with the moving low center of p_c . In terms of the moving system, Equation 13-4 is transformed into

$$\frac{d\hat{v}}{dt} + f\vec{K} \times (\hat{v} - \hat{v}_g) = -\frac{1}{\rho} \nabla p_c + \nabla \cdot (\kappa_H \nabla \hat{v}) - \frac{C_D}{h} |\hat{v} + \hat{v}_c| (\hat{v} + \hat{v}_c) \quad (13-5)$$

where

\vec{v} = horizontal wind velocity relative to the low center; $= \hat{v} - \vec{v}_c$
 \vec{v}_g = effective geostrophic flow relative to the low center; $= \hat{v}_g - \vec{v}_c$
 \vec{v}_c = velocity of the moving reference system relative to the fixed earth

$$\frac{d}{dt} = \left(\frac{\partial}{\partial t} \right)_c + \vec{v} \cdot \nabla$$

where $\left(\frac{\partial}{\partial t} \right)_c$ = time change local to the moving coordinate system;
 $= \frac{\partial}{\partial t} + \vec{v}_c \cdot \nabla$

8. Equation 13-5 can be expanded from vector form into equations involving the scalar x- and y-components of velocity. After some rearranging of terms, the equations to be solved are

$$\frac{du}{dt} = fv - P_x + H_x - F_x \quad (13-6)$$

$$\frac{dv}{dt} = -fu - P_y + H_y - F_y \quad (13-7)$$

where

u, v = components of \vec{v}

u_g, v_g = components of \vec{v}_g

$$P_x = fv_g + \frac{1}{\rho} \frac{\partial p_c}{\partial x}$$

$$P_y = -fu_g + \frac{1}{\rho} \frac{\partial p_c}{\partial y}$$

x, y = horizontal coordinates

H, F = functional operators defined as

$$H = \frac{\partial}{\partial x} \left(K_H \frac{\partial \cdot}{\partial x} \right) + \frac{\partial}{\partial y} \left(K_H \frac{\partial \cdot}{\partial y} \right)$$

$$F = \frac{C_D}{H} \left[(u + u_c)^2 + (v + v_c)^2 \right]^{1/2} (\cdot + \cdot_c)$$

u_c, v_c = components of \vec{v}_c

9. The general formulation is completed with the specification of the form of C_D , K_H and the boundary condition at the outermost boundary of the grid. Following Smagorinsky (1963) the horizontal eddy viscosity coefficient is given by

$$K_H = 2\kappa^2 \left(\frac{\Delta}{2}\right)^2 \left[\left(\frac{\partial u}{\partial x} - \frac{\partial v}{\partial y} \right)^2 + \left(\frac{\partial v}{\partial x} + \frac{\partial u}{\partial y} \right)^2 \right]^{\frac{1}{2}} \quad (13-8)$$

where

Δ - mesh size

κ - non-dimensional constant ($\kappa = 0.4$ is assumed)

The term in brackets in Equation 13-8 may be viewed as a total deformation due to tension and shearing strains. Drag coefficient is computed based on a revised PBL parameterization discussed later in this chapter. The boundary condition at the outermost boundary of the grid is obtained by neglecting acceleration and horizontal diffusion of momentum, implying a balance between Coriolis, pressure gradient, and surface friction forces. With this assumption, Equation 13-5 can be simplified along the outer boundary to

$$f\vec{k} \times (\vec{v} - \vec{v}_g) = -\frac{1}{\rho} \nabla p_c - \frac{C_D}{h} |\vec{v} + \vec{v}_c| (\vec{v} + \vec{v}_c) \quad (13-9)$$

10. Several options are available for specifying the pressure field. The simplest and most used is an axisymmetric pressure field defined by the well-known exponential pressure law. This expression, which is also used in the SPH (Chapter 3), is given by

$$p_c(r) = p_o + \Delta p e^{-r/R_p} \quad (13-10)$$

where

p_o - storm central pressure

Δp - storm pressure anomaly defined as

R_p - scale radius

r - radial distance from the eye

$$\Delta p = p_o - p_o \quad (13-11)$$

where p_o - axisymmetric ambient (far-field) pressure

11. A more general option is available in which the parameters Δp and R_p in Equation 13-10 can be specified by storm quadrant. The final pressure field under this option is devised by smoothing between the pressure variation specified for each quadrant.

12. Some storms are not well represented by Equation 13-10, even when the parameters are varied by quadrant. Options for more general specifications of *radially symmetric* pressure variation were introduced by Cardone et al. (1994). A more general form of Equation 13-10, which has proved successful in describing some storms (Holland 1980), is given by

$$p_c(r) = p_o + \Delta p e^{-(R_p/r)^B} \quad (13-12)$$

where B is a constant in the general range 0.5-2.5.

13. Field evidence has accumulated in recent years that the radial pressure profile in the inner core of some storms is so irregular that even Equation 13-12 provides a poor approximation. Willoughby (1990) and Black and Willoughby (1992) describe the tendency for concentric rings in the radial wind distribution to be a fairly typical characteristic of intense tropical cyclones. The rings appear to be related intimately to storm intensity evolution. A capability for modeling radial wind distributions with broad or double maxima can be added by extending the generalization of Equation 13-12 to a double exponential form (Cardone et al. 1994)

$$p_c(r) = p_o + \sum_{i=1}^2 dp_i e^{-(R_{pi}/r)^{B_i}} \quad (13-13)$$

where

dp_i = pressure anomaly for the i 'th component

R_{pi} = scale radius for the i 'th component

B_i = Holland's B coefficient for the i 'th component

Since the values of dp_i are constrained by the relationship

$$\sum_{i=1}^2 dp_i = p_o - p_o \quad (13-14)$$

only the values of Δp and dp_i need be specified to determine the value of dp_2 .

14. The boundary layer depth h was investigated by Cardone, Greenwood, and Greenwood (1992) for two historical hurricanes (Camille and Carla). They concluded that an appropriate boundary layer depth is approximately 500 m.

15. In summary, the main independent variables are:

p_c - central pressure

Δp - storm pressure anomaly

R_e, R_m - scale radius values

B, B_1 - Holland's (1980) B coefficients

dp_1 - pressure anomaly for inner component

u_o, v_o - components of storm forward speed

h - boundary layer depth

u_s, v_s - components of geostrophic steering flow

Either one or four values (by quadrant) may be provided for each of the first three variables if the simple pressure profile is used (Equation 13-10).

16. The computational grid is a system of rectangular nested grids within each of which the mesh is constant. Figure 13-1 shows the inner three nests in one quadrant of the grid system. Mesh size doubles with each successive nest, and each mesh extends 10 mesh spacings from the center. The number of nests is at most seven and generally at least five. If five nests are used and the mesh size of the innermost nest is 5 km, the second through fifth mesh sizes are 10, 20, 40, and 80 km, respectively, and the entire grid covers a square 1,600 km on a side. If seven nests are used and the resolution of the innermost nest is refined to 2 km, the other mesh sizes (nests two through seven) are 4, 8, 16, 32, 64, and 128 km, and the grid covers a 2,560-km square.

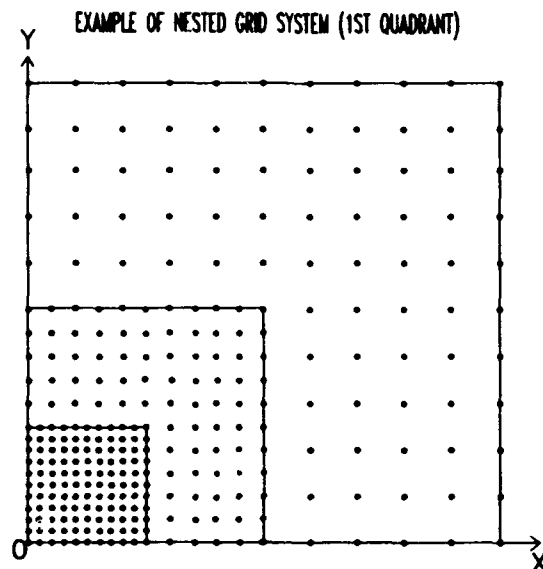

Figure 13-1. Example of nested grid system, first quadrant

17. Details of the finite difference formulation and of the computational scheme are given by Chow (1971) and are not repeated in detail here. Basically, a combination of diagonal and ordinary upstream differencing is used for spatial derivatives in order to reduce computational errors in the calculation of the advection terms and at the interior mesh boundaries. The computation starts with an initial guess field consisting of the gradient wind components (computed from p_c). At each grid point, Equations 13-6 and 13-7 are integrated forward in time until the acceleration $(\partial \vec{V} / \partial t)_c$ is tolerably small. The computational time-step, in seconds, is taken as ten times the finest computational mesh size, in kilometers. For example, if the innermost grid mesh size is 5 km, the time-step is 50 sec. Chow found that 800 iterations (equivalent to 13 hr 20 min if the time-step is 60 sec) were sufficient to achieve a steady-state solution. Cardone et al. (1994) recommended 3,200 iterations when using the generalized pressure specification.

18. The drag law used by Chow (1971) was revised by Cardone, Greenwood, and Greenwood (1992) to provide an accurate and consistent PBL wind and stress representation in the vortex model.

19. The framework for parameterization of the fluxes of momentum, heat, and moisture in the PBL was developed by Blackadar and Tennekes (1968) and Zilitinkevich (1969). The parametric relations result from the matching of mean profiles of wind, temperature, and moisture predicted by surface and outer-layer similarity theories for a PBL in which the flow is assumed to be horizontally homogeneous and quasi-stationary.

20. A particularly convenient form of the parameterization, first proposed by Deardorff (1972), expresses the PBL fluxes in terms of layer-averaged mean PBL properties. Deardorff's parameterization, combined with Cardone's roughness parameterization, has been found to provide reasonable results for hurricanes. The parameterization adapted in this model is taken from Arya's (1977) update of Deardorff's scheme.

21. The general form of the parametric relations may be written:

$$\frac{ku}{u_*} = -(\ln \hat{z}_* + A_m) \quad (13-15)$$

$$\frac{kv}{u_*} = -B_m \frac{f}{|f|} \quad (13-16)$$

$$\frac{k(\theta_v - \theta_*)}{\theta_*} = -(\ln \hat{z}_* + C_m) \quad (13-17)$$

$$\frac{k(q - q_*)}{q_*} = -(\ln \hat{z}_* + D_m) \quad (13-18)$$

where

- k - von Karman's constant
- u, v - vertically integrated (as in Equations 13-6 and 13-7) horizontal wind components (in the direction of the surface shear and perpendicular to it)
- u_* - friction velocity
- \hat{z}_* - roughness parameter normalized by the PBL height (z_*/h)
- A_m, B_m, C_m, D_m - universal functions of dimensionless similarity parameters
- $f/|f|$ - sign of f (+ or -)
- θ_* - mean layer virtual potential temperature at desired elevation
- θ_*, q_* - potential temperature and specific humidity at z_*
- θ_* - potential temperature scale expressed in terms of the heat flux
- q - specific humidity at desired elevation
- q_* - a specific humidity scale involving the moisture flux

22. The Monin-Obukov length L may be expressed in terms of θ_* and u_* since

$$L = \frac{-u_*^3 \theta_* \rho c_p}{kgH} = \frac{-u_*^2 \theta_*}{g\theta_*} \quad (13-19)$$

where H is the heat flux.

23. Two competing theories exist for the form of the universal functions. In one theory, known as the Rossby-number similarity theory, the boundary layer height is uniquely determined by u_*/f and L . For the near neutral hurricane PBL, that theory predicts the PBL to increase as the ratio u_*/f increases toward the center of storms, in apparent contradiction to observation.

24. In the generalized theory, the depth of the PBL h is specified as an independent variable. Arya (1977) presents expressions for the similarity functions in terms of this generalized theory as follows:

$$\begin{aligned}
 A_m &= \ln\left(-\frac{h}{L}\right) + \ln\frac{fh}{u_*} + 1.5 \\
 B_m &= 1.8\frac{fh}{u_*} e^{0.2h/L} & \frac{h}{L} \leq -2 \\
 C_m &= \ln\left(-\frac{h}{L}\right) + 3.7 & (\text{unstable})
 \end{aligned}
 \tag{13-20}$$

$$\begin{aligned}
 A_m &= -0.96\frac{h}{L} + 2.5 \\
 B_m &= 0.80\frac{h}{L} + 1.1 & \frac{h}{L} \geq +2 \\
 C_m &= -2.00\frac{h}{L} + 4.7 & (\text{stable})
 \end{aligned}
 \tag{13-21}$$

For near-neutral conditions, $-2 < h/L < 2$, A_m , B_m , and C_m are assumed to be given by linear interpolation between the above computed values at $h/L = \pm 2$.

25. In terms of the similarity relations (Equations 13-15 through 13-18), the drag coefficient with respect to the integrated PBL wind is

$$C_D = \frac{k^2}{(\ln \hat{z}_o + A_m)^2 + B_m^2}
 \tag{13-22}$$

while the angle β , between the surface wind and the integrated PBL wind, is

$$\beta = \tan^{-1}(v/u)
 \tag{13-23}$$

26. To incorporate the similarity theory in the hurricane model, two cases were considered:

- a. Land. In a PBL over land, the following parameters are prescribed: f , z_o , h , $\theta_s - \theta_o$. The parametric relations then define the following functions

$$C_D = F_1(|\vec{V}|)_{f, z_o, h, \theta_s - \theta_o}
 \tag{13-24}$$

$$\beta = F_2(|\vec{V}|)_{f, z_o, h, \theta_s - \theta_o}
 \tag{13-25}$$

- b. Water. Over water, the roughness parameter is not known but can be expressed in terms of u_* through a Charnock-type relation

$$z_0 = a \frac{u_*^2}{g} \quad (13-26)$$

or the form proposed by Cardone (1969). The parametric relations can then be solved for

$$C_D = F_3(|\vec{V}|)_{f, h, \theta_s, -\theta_s} \quad (13-27)$$

$$\beta = F_4(|\vec{V}|)_{f, h, \theta_s, -\theta_s} \quad (13-28)$$

27. The Charnock constant a and the constant k are assignable in the model. However, recommended values, based on the work of Garratt (1977) and Cardone, Greenwood, and Greenwood (1992), are

$$a = 0.035$$

$$k = 0.35$$

28. Some assumptions are introduced to simplify solution of the boundary layer. It is assumed that

$$\frac{fh}{u_*} = 1 \quad (13-29)$$

so that the similarity functions in Equation 13-20 depend only on the ratio h/L . Further, it is assumed that over water the air-sea temperature difference and boundary layer height can be considered to be invariant over the domain of the storm. This appears to be a reasonable approximation. Except for hurricanes crossing major ocean-current boundaries, the assumption of horizontal homogeneity of $\theta_s - \theta_0$ also seems reasonable, especially for Gulf of Mexico and lower U.S. east coast hurricanes. Little is known about the characteristics of the PBL in hurricanes over land. However, given the high level of turbulent mixing in hurricanes, it is reasonable to assume that an adiabatic lapse rate is established and that at least in the near-coastal zone, the boundary layer depth is close to that assumed for the over-water case.

29. Given the above conditions, the parametric relations F_1 , F_2 , F_3 , and F_4 can be found once for a given storm by iteration, and expressed in terms of tables. In practice, the upwind and crosswind drag coefficients, the ratio

$u_s/|\bar{V}|$, and the angle β between the surface wind and the integrated wind are computed and stored in a table for $|\bar{V}|$ values ranging from 0.8 to 80 m/sec in increments of 0.8 m/sec. Values for intermediate wind speeds are found by linear interpolation.

Terrain Transformation Model

30. In this section a simple model is developed to derive the surface wind and stress over terrain of arbitrary roughness from the numerical wind-field solution computed exclusively from the revised over-water drag formulation. The approach is to employ equilibrium PBL theory to relate the over-water integrated PBL wind to the flow at the top of the PBL and then to employ a consistent equilibrium model to compute the surface wind stress from the wind at the top of the PBL for terrain (including lakes) of arbitrarily specified roughness. The model proposed assumes that the PBL over land or inland lakes in a hurricane is neutrally stratified.

31. The transformations are derived quite simply from consideration of the alternate forms of the similarity PBL theory adapted in this study. Surface drag in the numerical vortex model was parameterized using Equations 13-15 and 13-16, which relate the stress to the integrated PBL wind. Alternatively (Arya 1977), surface drag may be referenced to the wind at the top of the PBL with components u_h and v_h :

$$\frac{ku_h}{u_*} = - (\ln \hat{z}_o + A) \quad (13-30)$$

$$\frac{kv_h}{u_*} = - B \frac{f}{|F|} \quad (13-31)$$

or to the surface geostrophic wind components

$$\frac{ku_z}{u_*} = - (\ln \hat{z}_o + A_o) \quad (13-32)$$

$$\frac{kv_z}{u_*} = - B_o \frac{f}{|F|} \quad (13-33)$$

As noted by Arya, A_o and B_o may be expected to differ from A and B due to the presence of baroclinicity and also in very low latitudes where winds are strongly geostrophic. In hurricanes, baroclinicity in the PBL may be ignored,

but the flow at the top of the PBL is more nearly in gradient balance. The effects of curvature on A and B have not been studied, but the success achieved with the similarity PBL theory in the overwater case suggests that such effects are not large. In this model, differences between A and B and A_0 and B_0 are ignored.

32. The relationship between A_0 and B_0 and A_m and B_m is given by Arya (1977) as derived from the equations of mean motion for a barotropic atmosphere in which the momentum flux is assumed to vanish at $z = h$:

$$A_m = A_0 \quad (13-34)$$

$$B_m = B_0 - k \left(\frac{fh}{u_*} \right)^{-1} \quad (13-35)$$

For the restricted case of $fh/u_* = 1$, which was adopted only for the purposes of attaining a workable parameterization, it can be shown simply from Equations 13-15 through 13-18, 13-30, 13-31, 13-34, and 13-35 that the flow at the top of the PBL, $z = h$, is related to the vertically integrated flow through

$$u_h = u \quad (13-36)$$

$$v_h = v - u_* \quad (13-37)$$

In the coordinate system adopted (see Figure 13-2), v_h is negative and u_h is always positive, so that the wind speed at the top of the PBL is always larger than the mean layer wind speed \bar{V} and turned clockwise (in the Northern Hemisphere) with respect to the mean layer wind \bar{V} .

33. Given the wind at level h , the consistent similarity theory defined by Equations 13-30 and 13-31 may be solved for the surface stress and surface layer wind in a neutral PBL over terrain of specified roughness z_0 . For a neutrally stratified PBL, A_0 and B_0 are reduced simply to constants (1.39 and $1.95 + k$, respectively). If z_0 is a constant, as, say, over a homogeneous land surface, u_* may be obtained directly from Equations 13-30 and 13-31. However, since roughness over a lake probably depends on u_* , z_0 may in general be prescribed in terms of u_* using the general form proposed by Cardone (1969):

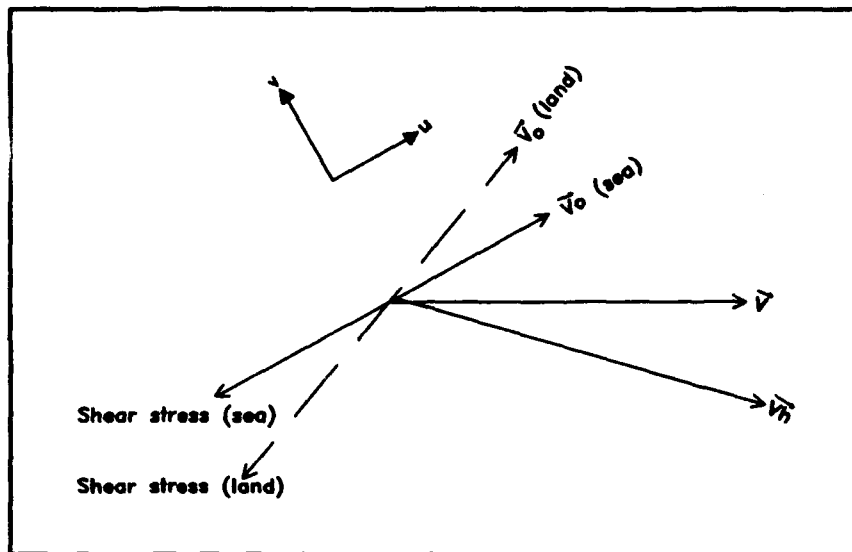

Figure 13-2. Internal coordinate system for PBL model

$$z_0 = C_1 \frac{1}{u_*} + C_2 u_*^2 + C_3 \quad (13-38)$$

where C_1 , C_2 , and C_3 are constants to be chosen to impose a desired drag law. (For example, for a Charnock law, $C_1 = C_3 = 0$, $C_2 = a/g$; for land, $C_1 = C_2 = 0$, C_3 is the roughness parameter for the terrain type).

34. Implementation of the above model in the specification of hurricane surface wind fields over terrain of arbitrary roughness or lakes is coded as subroutine UPDOWN, which allows for the calculation of transformations for up to six terrain categories. Roughness constants C_1 , C_2 , and C_3 are specified for each terrain category. The procedure followed is:

- a. Given the integrated boundary layer wind u , v , and the conditions of a given hurricane over water (h , $\theta_s - \theta_o$, f , k , a), compute u_* from the revised overwater similarity parameterization.
- b. From Equations 13-36 and 13-37, compute the wind speed and direction at level h , the top of the PBL.
- c. For each terrain roughness specified in terms of Equation 13-38, the neutral similarity model (13-30 and 13-31) is used to compute the friction velocity appropriate to the terrain roughness u_* , the ratio $u_*/|\vec{V}|$, and the angle between the surface stress and the integrated wind. The ratio and the turning angle are computed for $|\vec{V}|$ ranging from 0.8-80.0 m/sec in increments of 0.8 m/sec, for each roughness category and stored for use in the specification of surface winds in a given simulation over a grid covering different terrain types.

35. The overall behavior of the transformations is exemplified in Figure 13-3, which shows the ratio of surface wind speeds at 20 m (overland divided by oversea) and the difference between the overland and oversea inflow angle for two terrain roughnesses: 0.04 m and 0.32 m. For comparison, Figure 13-3 shows the results for the wind-speed ratio derived from numerical mixed-terrain and overwater solutions for a symmetric stationary vortex (radius and pressure drop as in Camille). To arrive at the indicated quantities, the surface wind speed and direction along a radial extending north of the eye over land in the mixed terrain case were referenced to the (symmetrical) solution along the radial for open ocean. It should be recalled that in the mixed-terrain solution, the wind field over land looked reasonable. Apparently, that solution can be retrieved simply from the overwater solution using the equilibrium model described above. It is also interesting to note that the form of the dependence shown in Figure 13-3 conforms closely to the empirical wind-speed ratio derived from measurements in hurricanes in and around Lake Okeechobee by the U.S. Weather Bureau, Hydrometeorological Section (Cardone, Greenwood, and Greenwood 1992).

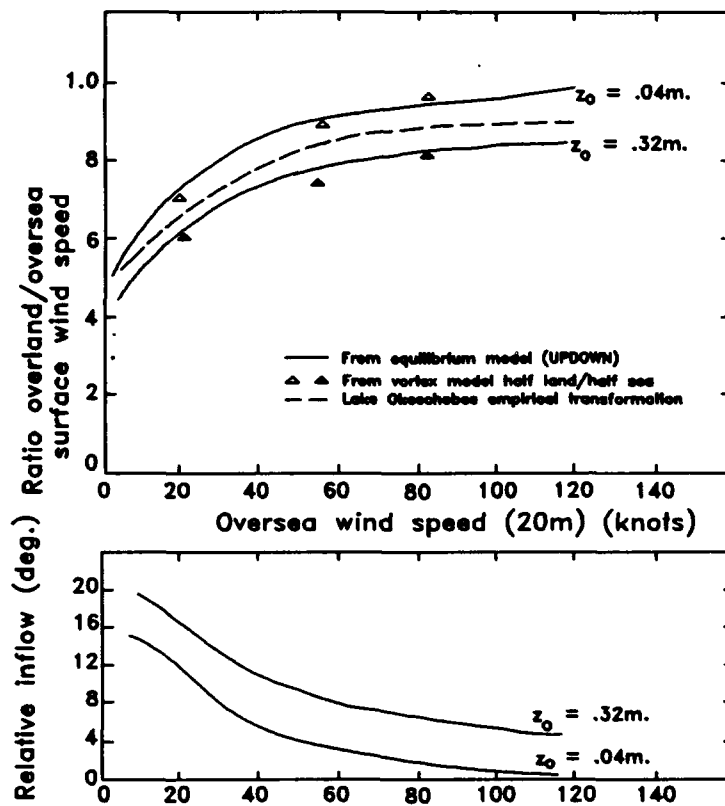

Figure 13-3. Behavior of overland/oversea transformation (from Cardone, Greenwood, and Greenwood (1992))

PART III: GENERAL STRUCTURE OF HURWIN

36. HURWIN was prepared to simplify usage of the tropical storm planetary boundary layer routines. The program, in conjunction with CMS library routines, assists with construction of input files, building SCRIPT files (job control language on the Cray supercomputer) to run the programs and manipulate files, and producing various output products. HURWIN is a branch of the CMS Spectral Wave Modeling Module. The name HURWIN represents the whole collection of codes needed to generate hurricane wind fields (wind direction and either wind speed or wind stress defined as u^2) with the planetary boundary layer model. An option is available to save pressure fields as well. The terms "tropical storm," "hurricane," and "typhoon" are used interchangeably. A hurricane is merely a tropical storm with maximum sustained wind speeds exceeding 75 mph. A typhoon is a tropical storm located west of the date line in the western Pacific Ocean. The present version of HURWIN is not generalized or verified for use with tropical storms in the Southern Hemisphere.

37. HURWIN is based on the concept that a tropical storm generally changes structure relatively slowly. For example, the structure of a hurricane traveling over open water can usually be well-represented by parameters specified at intervals of from 6 to 24 hr. These representative states are referred to as "snapshots" in HURWIN nomenclature. Although the structure typically changes slowly, the storm position can change relatively quickly. The differences in time scale between storm structure and position changes are accommodated in HURWIN by a very flexible procedure. The user is allowed to specify the position of the storm center at every hour. The appropriate snapshot or pair of snapshots for that hour is also specified. Snapshot(s) are assumed to be coincident with the actual storm center. If a pair of snapshots is given, the user specifies the relative weighting to be assigned to each snapshot and the wind field is linearly interpolated between the two snapshots. The user has additional flexibility through an option to rotate snapshots through any angle. This option changes the direction of storm approach.

38. The operational functions of the HURWIN branch of the Spectral Wave Modeling module are illustrated in Figure 13-4. The three main functions are: input file building, running programs, and post-processing. In general, the

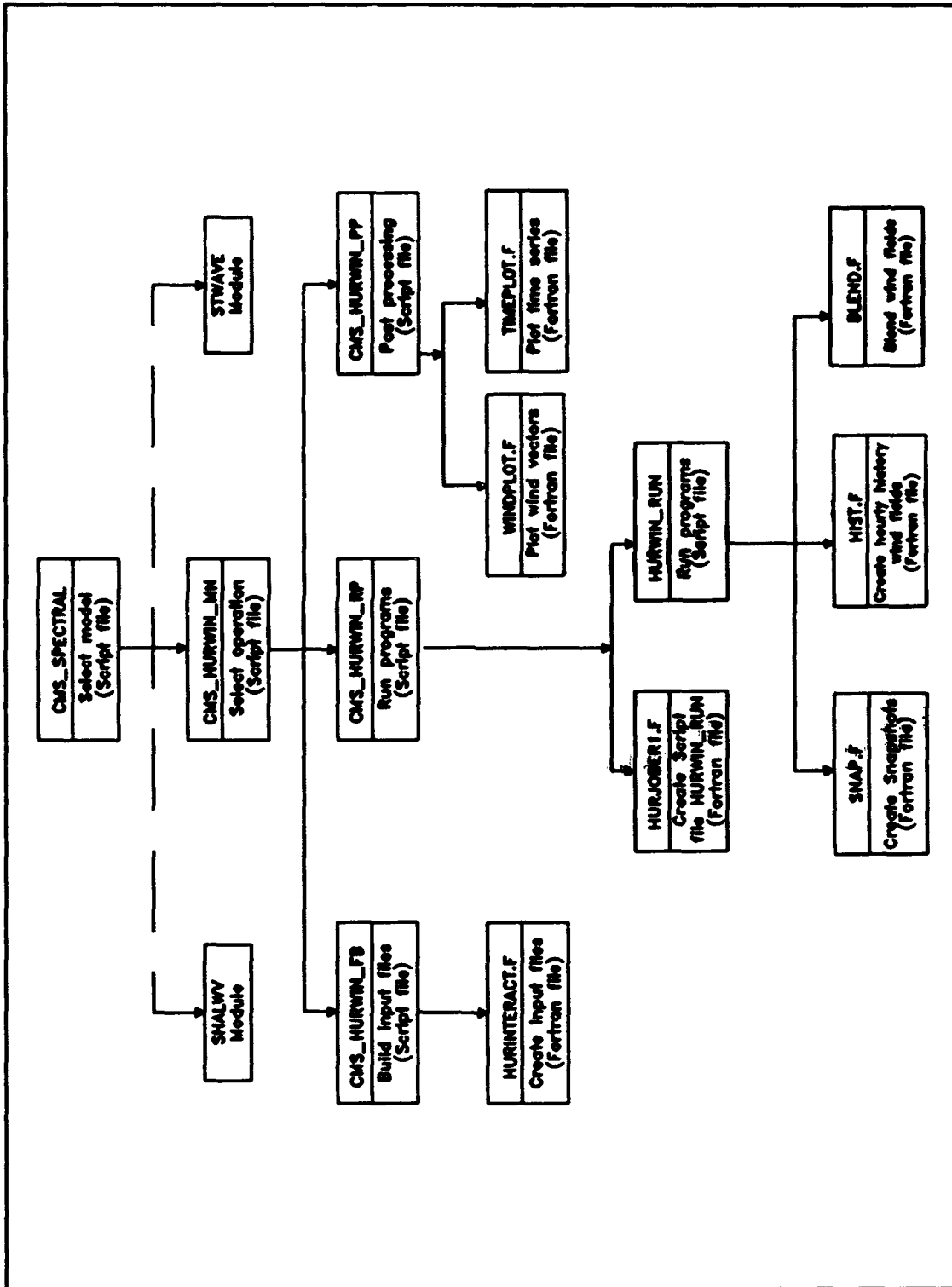

Figure 13-4. Operational functions of HURWIN

file-building function must be used prior to the functions to run programs and post-process the model results. The routines called under each function are represented in Figure 13-4. Those with names ending in ".F" are written in FORTRAN. The others are written in SCRIPT. The main purpose of each routine is as follows:

- CMS_HURWIN_MN: SCRIPT file to select the desired function (build input files, run, or post-process) and run the appropriate SCRIPT file.

File-Building Function

- CMS_HURWIN_FB: SCRIPT file to run input file-building routine.
- HURINTERACT.F: FORTRAN program to create input data files or specify input files that are already available, including: 1) namelists (described in a following section); 2) output grid information; 3) output station information; and 4) hourly time history information on the storm.

Run Programs Function

- CMS_HURWIN_RP: SCRIPT file to run HURJOB1.F and hurricane wind computation programs (HURWIN_RUN).
- HURJOB1.F: FORTRAN program to create SCRIPT file to run winds, including: 1) create HURWIN_RUN; 2) prompt user for output file name header; and 3) write output file names to a plotting file.
- HURWIN_RUN: SCRIPT file to run hurricane wind computation programs.
- SNAP.F: FORTRAN program to compute snapshot wind fields at specified times. (Note: There are two different programs here. HURWIN automatically invokes the proper program, depending on the parameters specified by the user. The program file "snap_adc.f" is used for the standard pressure profile; the program file "snap_hol.f" is used for the generalized pressure profile.)
- HIST.F: FORTRAN program to interpolate wind fields in space and time to provide hourly results at selected stations and/or output grid locations.
- BLEND.F: FORTRAN program to blend wind fields created during coarse (background) and fine resolution runs of SNAP.F and HIST.F to provide winds on the user-specified output grid. The blended wind field consists of winds from the fine grid over its coverage area and winds from the coarse grid (with 25-km cell size) for other output grid areas. A nearly identical program "blendp.f" performs the same function for pressure fields.

Post-Processing Function

- CMS_HURWIN_PP: SCRIPT file to run post-processing programs.
- WINDPLOT.F: FORTRAN program to plot wind fields.
- TIMEPLOT.F: FORTRAN program to plot time history of winds at selected stations or output grid locations.

39. Program HURWIN uses a number of files as inputs or outputs for various routines. Some of the files may be pre-existing files provided as input by the user, but most are created in HURWIN. Many files are created and used internally as part of the HURWIN stream of programs, and are not of direct interest to the user. The user has some freedom in specifying names of external input and output files. All internal files are pre-named. Figures 13-5 through 13-7 indicate the files created and used by each program in HURWIN. Each file has associated option and unit numbers. Unit numbers are arbitrary. They are important in understanding program operation, but they are irrelevant to a routine user. Required input files are identified with the letter "R." Files that are automatically created by routines are identified with the letter "A." Files that the user has an option of providing or not providing (though they may be required later in the program stream) are identified with the letter "O." The contents and format of data within each file are described in Part V. Coordination between programs in the three functions is evident in that files created in one function are often used as input in another function.

40. The organizational procedure for a typical simulation is as follows:

- Run the input file-building routine to provide input data on the simulation and desired output.
- Using the input data, run the computational programs to generate wind fields at desired stations and/or on a desired output grid.
- Plot time history of wind parameters at selected stations and/or plot full wind field at selected times.
- Use output wind fields as input to a wave, storm surge, or circulation model (e.g., the SHALWV wave branch of the Spectral Wave Modeling Module).

		FILE-BUILDING ROUTINE		FILE #
OPTION #	INPUT FILES		OUTPUT FILES	OPTION #
0	1	SNAPSHOT INPUT (USER-SPECIFIED NAME)		A 12
0	2	HOURLY HISTORY INPUT (USER-SPECIFIED NAME)	GENERAL	A 16
0	3	OUTPUT GRID PARAMETERS (USER-SPECIFIED NAME)	FILE	0 18
0	4	LAND/SEA (TERRAIN) TABLE (USER-SPECIFIED NAME)	BUILDING	0 14
				A 9
				A 8
				A 21
				A 22

*A = Automatically Created Output File
 0 = Optionnally Created or Required File
 R = Required Input File

Figure 13-5. File-building function

OPTION #		FILE #		RUN PROGRAMS ROUTINE		OPTION #		FILE #	
R	4	PARAMETER FILE (file1.hur)		RUN	JCL TO RUN WIND COMPUTATIONAL PROGRAMS (hurwin_run)	A	10		
R	8	FILE NAMES (filenmi.hur)		hurjober1	FILE NAMES, POST-PROCESSING (filenmpst.hur)	A	15		
R	12	SNAPSHOT INPUT (snapin.hur)		RUN	SNAPSHOT INFORMATION (fort.13)	A	13		
R	21	VERSION OF SNAP (snap1.hur or snap2.hur)		snap	GENERAL RUN INFORMATION (fort.25)	A	25		
R	4	PARAMETER FILE (file1.hur)							
R	16	HOURLY HISTORY INPUT (histin.hur)		RUN	INITIAL WIND FIELD OR WIND STRESS FIELD (wind01 or wind02)	A	20		
O	18	OUTPUT GRID PARAMETERS (gridparm.hur)		hist	WIND CHARACTERISTICS (USER-SPECIFIED + .sum)	A	9		
O	14	LAND/SEA (TERRAIN) TABLE (lndsea.hur)			INITIAL PRESSURE FIELD (pres01 or pres02)	O	17		
R	13	SNAPSHOT INFORMATION (fort.13)			GENERAL RUN INFORMATION (fort.26)	A	26		
R	4	PARAMETER FILE (file1.hur)							
R	7	INITIAL WIND OR PRESSURE FIELD ON COARSE GRID (wind01 or pres01)		RUN	FINAL OUTPUT WIND OR PRESSURE FIELD (USER-SPECIFIED + .win OR USER-SPECIFIED + .prs)	A	11		
R	8	INITIAL WIND OR PRESSURE FIELD ON FINE GRID (wind02 or pres02)		blend					
R	4	PARAMETER FILE (file1.hur)							
<p>*A = Automatically Created Output File O = Optionally Created or Required File R = Required Input File</p>									

Figure 13-6. Run programs function

POST-PROCESSING ROUTINES		FILE #	OPTION #
R	7	FILE NAMES (filermi.hur)	
R	8	FILE NAMES (filermpst.hur)	
R	1	HISTORY INPUT FILE (histin.hur)	
R		PARAMETER FILE (filel.hur)	
R	3	WIND FIELD (USER-SPECIFIED + .win)	
R	11	WIND CHARACTERISTICS (USER-SPECIFIED + .sum)	
		GRAPHICS	
		SCREEN DISPLAYS NO FILES	
R	12	FILE NAMES (filermpst.hur)	0 NA
R	5	FILE NAME FILE (filermi.hur)	0 NA
R	2	HISTORY INPUT FILE (histin.hur)	0 NA
R	9	WIND FIELDS (USER-SPECIFIED + .win)	
R	11	WIND CHARACTERISTICS (USER-SPECIFIED + .sum)	
		STATISTICS	
		WIND CHARACTERISTICS FILE (USER-SPECIFIED) GENERAL STATISTICS FILE (USER-SPECIFIED) WIND FIELD OUTPUT FILE (USER-SPECIFIED)	

*A - Automatically Created Output File
 O - Optionally Created or Required File
 R - Required Input File

Figure 13-7. Post-processing function

PART IV: HURWIN MODULE FUNCTIONS AND ROUTINES

41. The first function of the HURWIN branch of the Spectral Wave Modeling module of CMS is to build most or all of the necessary input files for the user's application. The second function is to run the computational programs. The third function is to display graphically or statistically the results of the user's most recent HURWIN run. Descriptions of the operation of each function and routine and the specific information required by each function and routine are presented in the following sections.

File-Building Function

42. The first function of the HURWIN module is to assist users in building the input files required. Users are prompted for input through a series of menu selections and question-answer sessions. It is recommended that the file-building function routines be used at all times to organize data and files for a HURWIN run. This precaution will minimize potential file format and organizational errors.

43. The HURWIN file-building function includes options to use any pre-existing input files. File names of pre-existing files must be different from the file names used in HURWIN. For example, a pre-existing file must not be named 'snapin.hur.' The user can specify which files are already complete and which files need to be built. Then HURWIN will assist the user in building the necessary files. It will also show the user the contents of pre-existing files, give the user an opportunity to change any values, and write the pre-existing information, with any user-specified changes, to the appropriately named HURWIN input files.

44. The input file-building routine is used to construct the required files of namelists 1, 2, and 3 (snapin.hur); namelists 4 and 5, station and history parameters (histin.hur); parameter file (file1.hur); main file of file names (filenmi.hur); output grid parameters (gridparm.hur); and land/sea table (lndsea.hur). The latter two files are optional, needed only when an output grid of winds is desired.

45. Descriptions of the data requested by the input file-building routine (HURINTERACT.F) are provided below. The descriptions have the following format: the prompts that the user will see during the interactive file-building session are provided by "Question:" as they would appear on the

user's terminal during the interactive file-building session along with an identifying number for reference (e.g. GF-1, which stands for General File Building question number 1). A list of "Options:" is provided, which may be used to answer the question. If the question allows only a limited range of responses, then the permitted range of values is given. Some questions allow the user to choose preset responses, defined in "Default:". Also the FORTRAN name of the variable being specified is given in parentheses on the "Default:" line. "Preselect:" identifies answers to previous questions that are required in order for the user to encounter the current question. For example, question GF-7 will be asked only if the user previously answered "Yes" to question GF-6. Each question is explained under the "Define:" section, and a list of "Cautions:" is provided when appropriate to alert users to special requirements of the module. When necessary, a "PATH:" is provided that indicates which question is next based on answers to previous questions. While all of the possible questions are listed below, the user will not encounter all of them in any simulation.

- GF-1 Question : Enter DESIRED SYSTEM OF UNITS >
Options : 1 - METRIC (m & km, s, m/s, Deg-C)
2 - ENGLISH1 (ft & miles, s, mph, Deg-F)
3 - ENGLISH2 (ft & nm, s, knots, Deg-F)
4 - OCEANWEA (units of Cardone et al. 1992)
Default : 4 (IUNITS)
Preselect : None.
Define : Select the system of units to be used for user-specified input.
Caution : None.
- GF-2 Question : Enter FOUR CHARACTER NAME OF STORM >
Options : Any group of up to four characters or numbers.
Default : None. (STORM)
Preselect : None.
Define : Specify an identifying name for the storm.
Caution : None.
- GF-3 Question : Enter NUMBER OF SNAPSHOTS >
Options : value > 0
Default : None. (NZ)
Preselect : None.

Define : Specify the number of snapshots to be read.
 Caution : None.

GF-4 Question : Enter TIME ZONE FOR STARTING TIME >
 Options : 1 - (UTC) Universal Time Coordinate (formerly GMT)
 2 - (EST) Eastern Standard Time
 3 - (EDT) Eastern Daylight Time
 4 - (CST) Central Standard Time
 5 - (CDT) Central Daylight Time
 Default : 1 (IZONE)
 Preselect : None.
 Define : Select time zone for input and output.
 Caution : None.

GF-5 Question : Enter STARTING TIME (YYMMDDHH) >
 Options :
 Default : None. (ISTART)
 Preselect : None.
 Define : Enter the year, month, day, and hour for the first simulation time.
 Caution : None.

GF-6 Question : Change parameters in roughness law? >
 Options : Y - yes, change at least one parameter;
 N - no, use default values.
 Default : None. (REPLY)
 Preselect : None.
 Define : Provides an option to change roughness law parameters.
 Caution : None.

PATH: o IF "N" ON GF-6, GO TO GF-14.

GF-7 Question : Enter AIR-LAND TEMP DIFFERENCE (Deg-C, Deg-F) >
 Options : -12.0 ≤ value ≤ 12.0
 Default : 0.0 (DTH1)
 Preselect : GF-6, option "Y".
 Define : Specify temperature difference between air and land.
 (+ = land temperature is lower, - = land temperature is higher)
 Caution : None.

GF-8 Question : Enter AIR-SEA TEMP DIFFERENCE (Deg-C, Deg-F) >
 Options : -12.0 ≤ value ≤ 12.0.

Default : -2.0 (DTH2)
 Preselect : GF-6, option "Y".
 Define : Specify temperature difference between air and water.
 (+ = sea temperature is lower, - = sea temperature is higher).
 Caution : None.

GF-9 Question : Enter BOUNDARY LAYER HEIGHT OVER WATER (m,ft) >
 Options : 0.0 < value ≤ 2000.0 m;
 0.0 < value ≤ 6600.0 ft.
 Default : 500.0 m; 1640.4 ft. (HH)
 Preselect : GF-6, option "Y".
 Define : Specify the height of the planetary boundary layer over water.
 Caution : The default value should be used unless the user has specific knowledge about the storm being modeled.

GF-10 Question : Enter POTENTIAL TEMPERATURE (deg C, deg F, deg K) >
 Options : 0.0 ≤ value ≤ 47.0 deg C
 32.0 ≤ value ≤ 116.6 deg F
 280 ≤ value ≤ 320 deg K
 Default : 26.85 Deg-C; 80.33 deg F; 300 deg K. (PTH)
 Preselect : GF-6, option "Y".
 Define : Specify the potential temperature.
 Caution : The default value should be used unless the user has specific knowledge about the storm.

GF-11 Question : Enter VON KARMAN'S CONSTANT >
 Options : 0.3 ≤ value ≤ 0.5
 Default : 0.35 (K35)
 Preselect : GF-6, option "Y".
 Define : Specify value of von Karman's constant.
 Caution : The default value is recommended.

GF-12 Question : Enter ROUGHNESS LENGTH OVER LAND >
 Options : 0.0 < value < 1.0
 Default : 0.08 (ZOLAND)
 Preselect : GF-6, option "Y".
 Define : Specify the characteristic roughness length over land.
 Caution : None.

GF-13 Question : Enter CHARNOCK'S CONSTANT >
 Options : 0.01 ≤ value ≤ 0.05.

Default : 0.035 (GARR)
 Preselect : GF-6, option "Y".
 Define : Specify Charnock's constant.
 Caution : The default value is recommended.
 GF-14 Question : Do you want to change any of the Z0 coeff.? >
 Options : Y - yes, change at least one set of coeff.;
 N - no, use default values.

Default : (ZCOEFF)

<u>Terrain</u>	<u>C₁</u>	<u>C₂</u>	<u>C₃</u>
1) Lake	0.0	0.0037	0.015
2) Marsh	0.0	0.0	0.04
3) Plains	0.0	0.0	0.16
4) Woods	0.0	0.0	0.32
5) Cities	0.0	0.0	1.28

Preselect : None.
 Define : Provides an option to change roughness law coefficients for non-open water terrains (Equation 13-25). Note that the coefficients are dimensioned in metric units.
 Caution : None.

PATH: o IF "N" ON GF-14, GO TO GF-19.

GF-15 Question : Correct which number ? (1-5) >
 Options : 1 ≤ value ≤ 5
 Default : None.
 Preselect : GF-14, option "Y".
 Define : Specify terrain for which new roughness coefficients are desired. Terrain type identification numbers are given with GF-14.
 Caution : None.

GF-16 Question : Enter value C1:
 Options :
 Default : None.
 Preselect : GF-14, option "Y".
 Define : Specify value for C₁ in roughness law (Equation 13-25).
 Caution : There are no internal checks to ensure that reasonable values are entered.

GF-17 Question : Enter value C2:
 Options :

Default : None.
Preselect : GF-14, option "Y".
Define : Specify value for C_2 in roughness law
(Equation 13-25).
Caution : There are no internal checks to ensure that
reasonable values are entered.

GF-18 Question : Enter value C3:
Options :
Default : None.
Preselect : GF-14, option "Y".
Define : Specify value for C_3 in roughness law
(Equation 13-25).
Caution : There are no internal checks to ensure that
reasonable values are entered.

GF-19 Question : Enter CHOICE FOR PRESSURE SPECIFICATION >
Options : 1 - standard (single exponential)
2 - generalized (double exponential)
Default : 1 (IPSPEC)
Preselect : None.
Define : Specify form of pressure profile.
Caution : None.

GF-20 Question : Enter NUMBER OF COMPUTATIONAL NESTS (5-7) >
Options : $5 \leq \text{value} \leq 7$
Default : 7 (NESTS)
Preselect : None.
Define : Specify number of grid nests to be used in
computing the vortex wind fields.
Caution : None.

GF-21 Question : Enter INNERMOST GRID SPACING (km,miles,nm) >
Options : 0.0 < value < 20.0 km
0.0 < value < 12.4 miles
0.0 < value < 10.8 nm
Default : 2.0 km; 1.2 miles; 1.0 nm. (DXX)
Preselect : None.
Define : Specify spacing between points in the
innermost (and finest) nested grid to be used
for computation. DXX is converted to the
parameter DX described by Cardone et al. (1994).
Caution : None.

GF-22 Question : Enter NUMBER OF WIND COMPUTATION CYCLES >
Options : 0 < value < 4,000
Default : 800 (GF-19, option "1");
3200 (GF-19, option "2") (NM)
Preselect : None.
Define : Specify number of iterations to be used in
computing the vortex wind fields.
Caution : Default values are recommended.

GF-23 Question : Enter PRESSURE FIELD QUADRANT INDICATOR >
Options : 0 - circularly symmetric pressure field.
1 - first quadrant is right front.
2 - first quadrant is forward.
Default : 0 (IQUAD)
Preselect : GF-19, option "1".
Define : Specify whether the pressure field is to be
circularly symmetric or not. If not, specify
the location of the first quadrant.
Caution : None.

***** Questions GF-24 through GF-35 are repeated
***** for each snapshot.

GF-24 Question : Enter SURFACE GEOSTROPHIC WIND, SGW
(m/s, mph, knots)>
Options : 0.0 ≤ value < 50.0 m/sec.
0.0 ≤ value < 111.85 mph.
0.0 ≤ value < 97.2 knots.
Default : None. (SGW)
Preselect : None.
Define : Specify the speed of the surface geostrophic
wind or steering flow (i.e., the wind which
would be present if the hurricane were not
there).
Caution : None.

GF-25 Question : Enter DIRECTION OF SGW (Deg) >
Options : 0.0 ≤ value < 360.0
Default : None. (AN1)
Preselect : None.
Define : Specify the direction from which the surface

geostrophic wind is blowing, in deg azimuth
(meteorological convention).

- Caution : Some old parameter files may be based on other conventions, such as direction toward which the wind is blowing and deg measured counterclockwise from the x-axis (Cardone, Greenwood, and Greenwood 1992).
- GF-26 Question : Enter NORTH LATITUDE OF EYE OF STORM (Deg) >
Options : 0.0 < value < 90.0
Default : None. (EYELAT)
Preselect : None.
Define : Specify latitude coordinate of storm eye (Northern Hemisphere).
Caution : The value entered should best characterize the snapshot (even though it may actually be changing).
- GF-27 Question : Enter TRACK DIRECTION, clockwise from north >
Options : 0.0 ≤ value < 360.0
Default : None. (DIREC)
Preselect : None.
Define : Specify direction toward which storm is moving, in deg azimuth.
Caution : None.
- GF-28 Question : Enter FORWARD SPEED OF STORM (m/s, mph, knots) >
Options : 0.0 ≤ value < 50.0 m/s
0.0 ≤ value < 111.85 mph
0.0 ≤ value < 97.2 knots
Default : None. (SPEED)
Preselect : None.
Define : Specify forward translation speed of storm.
Caution : None.
- GF-29 Question : Enter PRESSURE AT EYE OF STORM (mb) >
Options : 850.0 ≤ value < 1,000.0 mb
Default : None. (EYPRES)
Preselect : None.
Define : Specify central pressure of storm.
Caution : None.
- GF-30 Question : Enter PRESSURE PROFILE SCALE
RADIUS(km, miles, nm) >
Options : 0.0 < value ≤ 200.0 km

0.0 < value ≤ 125.0 miles
 0.0 < value ≤ 125.0 nm

Default : None. (RADIUS)

Preselect : GF-19, option '1' and GF-23. If GF-23, option '0' is chosen, only 1 value for RADIUS is needed (other 3 default to 0). If '1' or '2' option is chosen, four values for RADIUS are needed. GF-19, option '2'. Two values for RADIUS are needed.

Define : Specify scaling radius (often equivalent to "radius to maximum wind") for storm.

Caution : None.

GF-31 Question : Enter FAR FIELD PRESSURE (mb) >

Options : 950.0 < value < 1,050.0 mb

Default : None. (PFAR)

Preselect : None.

Define : Specify atmospheric pressure outside the hurricane area.

Caution : None.

GF-32 Question : Enter DISTANCE FROM AXIS TO 0.5 SGW (km,miles,nm)>

Options : 0 ≤ value

Default : 0.0 (ST12)

Preselect : GF-19, option '1'.

Define :

Caution : The default value is recommended.

GF-33 Question : Enter EXPONENT FOR INNER PRESSURE RADIUS >

Options : 0.0 < value ≤ 3.0

Default : 1.0 (B1)

Preselect : GF-19, option '2'.

Define : Specify Holland's (1980) B coefficient for the inner pressure component.

Caution : None.

GF-34 Question : Enter EXPONENT FOR OUTER PRESSURE RADIUS > 0.0

Options : 0.0 ≤ value ≤ 3.0

Default : 0.0 (B2)

Preselect : GF-19, option '2'.

Define : Specify Holland's (1980) B coefficient for the outer pressure component.

Caution : Automatically set to 0.0 if DP1 not specified

(GF-35) or if DP1=PFAR-EYPRES. If B2=0.0, the second value of RADIUS (GF-30) is set to 0.0.

GF-35 Question : Enter PRESS. DIFF. BETW. EYE & INNER RADIUS (mb) >
Options : 0.0 ≤ value ≤ (PFAR - EYPRES)
Default : PFAR - EYPRES (DP1)
Preselect : GF-19, option '2'.
Define : Specify pressure anomaly for the inner pressure component.
Caution : Automatically set to PFAR - EYPRES if B2 = 0.0 (GF-34).

***** Questions GF-24 through GF-35 are repeated
***** for each snapshot.

GF-36 Question : Enter OUTPUT FIELD OPTION >
Options : 1 - surface wind speed and direction.
2 - surface wind stress.
Default : 1 (IFIELD)
Preselect : None.
Define : Specify the type of output desired. The wind stress option gives u^2 as output instead of wind speed.
Caution : None.

GF-37 Question : Enter DESIRED WIND ELEVATION (m,ft) >
Options : 0.0 < value ≤ 500.0
Default : 10.0 m; 33.0 ft (GRIDHT)
Preselect : GF-36, option "1".
Define : Specify the elevation above the water at which wind output is desired.
Caution : None.

GF-38 Question : Enter DESIRED OUTPUT UNITS > 2
Options : 1 - m/sec
2 - knots
Default : 2 (KSPD)
Preselect : GF-36, option "1".
Define : Specify the desired units for output wind speed.
Caution : None.

GF-39 Question : Enter DESIRED DIRECTION OUTPUT UNITS > 2
Options : 1 - meteorological convention (deg azimuth, coming from)

2 - WIS convention (Figure 13-8)

Default : 2 (KDIR)

Preselect : None.

Define : Specify the desired units for output wind direction.

Caution : None.

GF-40 Question : Enter DESIRED OUTPUT OPTION > 0

Options : 0 - suppress pressure field output
1 - create pressure field output

Default : 0 (PRSOUT)

Preselect : None.

Define : Specify whether an output file of pressure fields is desired.

Caution : None.

GF-41 Question : Enter DESIRED OPTION FOR PRINTING >

Options : 0 - suppress printing
1 - print pressures and initial winds (first snapshot only)

Default : 0 (IB)

Preselect : None.

Define : Specify whether or not detailed printouts are desired for the first snapshot.

Caution : The default value is recommended.

GF-42 Question : Do you want winds interpolated to output grid? >

Options : Y - yes, interpolate winds to output grid;
N - no, do not use output grid.

Default : Y (INTERP)

Preselect : None.

Define : Specify whether winds are to be interpolated onto an output grid.

Caution : None.

PATH: o IF "N" ON GF-42, GO TO GF-52.

GF-43 Question : Enter INTERVAL (hrs) TO PRINT WINDS ON GRID >

Options : 0 ≤ value

Default : None. (NPRT)

Preselect : GF-42, option Y.

Define : Specify time interval in hours at which printed winds are desired. NPRT equal to 0 suppresses printing.

Caution : If NPRT equal to 0, printing of selected windfields can still be done using NRPTGRID (GF-69).

GF-44 Question : Enter LATITUDE FOR NORTH EDGE OF GRID (Deg) >
Options : $0 \leq \text{value} < 90.0$
Default : None. (LATN)
Preselect : GF-42, option Y.
Define : Specify latitude boundary of output grid.
Caution : None.

GF-45 Question : Enter LATITUDE FOR SOUTH EDGE OF GRID (Deg) >
Options : $0 \leq \text{value} \leq 90.0$
Default : None. (LATS)
Preselect : GF-42, option Y.
Define : Specify latitude boundary of output grid.
Caution : LATS cannot be greater than LATN; grid must be in Northern Hemisphere.

GF-46 Question : Enter LONGITUDE FOR WEST EDGE OF GRID (Deg) >
Options : $0 \leq \text{value} \leq 360.0$
Default : None. (LONW)
Preselect : GF-42, option Y.
Define : Specify longitude boundary of output grid.
Caution : If the grid falls west of the International Date Line, longitudes must be increased above 180 deg. Negative longitude values are not permitted. LONW cannot be less than LONE.

GF-47 Question : Enter LONGITUDE FOR EAST EDGE OF GRID (Deg) >
Options : $0 < \text{value} \leq 360.0$
Default : None. (LONE)
Preselect : GF-42, option Y.
Define : Specify longitude boundary of output grid.
Caution : LONE cannot be greater than LONW.

GF-48 Question : Enter GRID CELL SPACING (Deg) >
Options : $\text{value} > 0.0$
Default : None. (DXOUT)
Preselect : GF-42, option Y.
Define : Specify spacing between points on the output grid.
Caution : Spacing must be the same (in terms of degrees) in both the latitude and longitude directions.

GF-49 Question : Enter the LAND/WATER MATRIX OPTION >
Options : 1 - enter the matrix interactively.
 2 - set constant land/water parameter.
Default : None. (IOPTION)
Preselect : GF-42, option Y.
Define : Specify whether or not the land/water matrix
 values are constant.
Caution : None.

GF-50 Question : Enter TERRAIN CODE >
Options : 1 - open water
 2 - lake
 3 - marsh
 4 - plains
 5 - woods
 6 - city
Default : 1 (LANDSEA)
Preselect : GF-42, option Y; GF-49, option 2.
Define : Specify a single terrain code to be used for
 the entire land/water matrix.
Caution : None.

GF-51 Question : Enter TERRAIN CODE FOR LAND/WATER MATRIX >
Options : Same as for GF-50.
Default : None. (LSTAB(NX,NY))
Preselect : GF-42, option Y; GF-49, option 1.
Define : Specify the terrain code for each point in the
 land/water matrix. The user is prompted for
 each value.
Caution : None.

GF-52 Question : Enter NUMBER OF MEASUREMENT STATIONS >
Options : $0 \leq \text{value} \leq 100$
Default : None. (NOGAGES)
Preselect : None.
Define : Specify the number of measurement stations.
Caution : None.

PATH: o IF VALUE = 0 ON GF-52, GO TO GF-60.

***** Questions GF-53 through GF-59 are repeated
***** for each station.

- GF-53 Question : Enter DEGREES OF NORTH LATITUDE >
Options : $0 \leq \text{value} < 90$
Default : None. (NORLATD)
Preselect : GF-52, value > 0
Define : Specify station latitude coordinate.
Caution : None.
- GF-54 Question : Enter MINUTES OF LATITUDE >
Options : $0 \leq \text{value} < 60$
Default : None. (NORLATM)
Preselect : GF-52, value > 0
Define : Specify station latitude coordinate.
Caution : None.
- GF-55 Question : Enter DEGREES OF WEST LONGITUDE >
Options : $0 \leq \text{value} < 360$
Default : None. (WESLOND)
Preselect : GF-52, value > 0
Define : Specify station longitude coordinate.
Caution : None.
- GF-56 Question : Enter MINUTES OF LONGITUDE >
Options : $0 \leq \text{value} < 60$
Default : None. (WESLONM)
Preselect : GF-52, value > 0
Define : Specify station longitude coordinate.
Caution : None.
- GF-57 Question : Enter TERRAIN CODE FOR STATION >
Options : 1 - open water
2 - lake (continued)

3 - marsh

4 - plains

5 - woods

6 - city

Default : 1 (ITERRAIN)

Preselect : GF-52, value > 0

Define : Specify terrain code for station.

Caution : None.

GF-58 Question : Enter STATION HEIGHT IN METERS >

Options : $0.0 \leq \text{value} \leq 50.0$

Default : 10.0 (GAGEHGT)

Preselect : GF-52, value > 0

Define : Specify elevation of station.

Caution : None.

GF-59 Question : Enter STATION NUMBER >

Options : $0 \leq \text{value} \leq 999$

Default : None. (IDGAGE)

Preselect : GF-52, value > 0

Define : Specify station identification number.

Caution : None.

***** Questions GF-53 through GF-59 are repeated
***** for each station.

GF-60 Question : Enter NUMBER OF HOURS FOR HISTORY >

Options : $0 < \text{value} \leq 300$

Default : None. (NOHRS)

Preselect : None.

Define : Specify number of hours for time-history of
storm.

Caution : None.

***** Questions GF-61 through GF-69 are repeated
***** for each history hour.

- GF-61 Question : Enter DEG OF NORTH LATITUDE OF EYE OF STORM>
Options : $0 \leq \text{value} < 90$
Default : None. (HISNLATD)
Preselect : None.
Define : Specify latitude coordinate of storm eye
(Northern Hemisphere).
Caution : None.
- GF-62 Question : Enter MIN OF NORTH LATITUDE OF EYE OF STORM>
Options : $0 \leq \text{value} < 60$
Default : None. (HISNLATM)
Preselect : None.
Define : Specify latitude coordinate of storm eye.
Caution : None.
- GF-63 Question : Enter DEG OF WEST LONGITUDE OF EYE OF STORM>
Options : $0 \leq \text{value} < 360$
Default : None. (HISWLOND)
Preselect : None.
Define : Specify longitude coordinate of storm eye
(Western Hemisphere).
Caution : None.
- GF-64 Question : Enter MIN OF WEST LONGITUDE OF EYE OF STORM>
Options : $0 \leq \text{value} < 60$
Default : None. (HISWLONM)
Preselect : None.
Define : Specify longitude coordinate of storm eye.
Caution : None.
- GF-65 Question : Enter SEQ. NO. OF 1ST SNAPSHOT WIND FIELD >
Options : $1 \leq \text{value} < \text{NZ}$
Default : None. (NOISNAP)
Preselect : None.
Define : Specify sequence number of first snapshot to
be used in interpolating winds for this hour.
Caution : None.

GF-66 Question : Enter SEQ. NO. OF 2ND SNAPSHOT WIND FIELD >
 Options : NO1SNAP ≤ value ≤ NZ; or value = 0
 Default : 0 (NO2SNAP)
 Preselect : None.
 Define : Specify sequence number of second snapshot to
 be used in interpolating winds for this hour.
 Normally NO2SNAP is equal to NO1SNAP + 1.
 Caution : None.

GF-67 Question : Enter INTERPOLATION DISTANCE (1ST,2ND SNAPSHOTS)>
 Options : 0.0 < value < 1.0
 Default : None. (DISTANCE)
 Preselect : GF-3, value > 1
 GF-66, value > NO1SNAP
 Define : Specify the proportionate weighting to be
 given to the second snapshot wind field during
 interpolation. A weighting of 1 - DISTANCE
 will be given to the first snapshot wind
 field.
 Caution : None.

GF-68 Question : Enter CLOCKWISE ROTATION OF SNAPSHOT (Deg) >
 Options : 0 ≤ value < 360
 Default : 0 (IROTATE)
 Preselect : None.
 Define : Specify the clockwise rotation to be given to
 the snapshot. When this parameter is not
 equal to zero, the storm direction will be
 rotated. The default value (no rotation) is
 recommended.
 Caution : None.

GF-69 Question : Enter DESIRED OPTION FOR PRINTING >
 Options : 0 - no printing of output grid wind field
 1 - print output grid wind field
 Default : 0 (NPRTGRID)
 Preselect : None.
 Define : Specify desired printing option for each
 history hour. When NPRTGRID is set to 1, it
 overrides NPRT (GF-43) and causes printing.
 Caution : When NPRTGRID is set to 0, printing is
 controlled by NPRT.

PATH: o END GENERAL FILE BUILDING SESSION

Run Programs Function

46. When the user is ready to initiate the run programs function, all of the necessary input data must be composed and formatted into the proper files. After selecting the run programs function, the user is asked to specify a reference name under which the output data will be stored. The reference name must conform to the file name conventions of the UNIX operating system. Up to 10 characters can be specified in the name. The name must NOT have a file name extension (e.g. ".dat" or ".out") because this part of the file name is specified by the program. The user-specified reference name is attached to three output files, each with its own extension.

47. One output file created by HURWIN is the Final Output Wind Field File (given the ".win" extension) which contains a date header and the wind speed or stress matrix and direction matrix for each point on the user-specified output grid and each hourly output interval of the simulation. Another output file is the Wind Characteristics File (given the ".sum" extension) which contains time histories of wind speed and direction for each user-specified output station (questions GF-52 through GF-59). Wind speeds are in m/sec or knots (as selected in GF-38). Wind directions are given either in the coordinate system used for input to the SHALWV wave model (Figure 13-8) or following a meteorological convention, depending on the selection in GF-39. The third (optional) output file is the Final Output Pressure Field File (given the ".prs" extension), which contains a date header and the pressure matrix for each point on the user-specified output grid and each hourly output interval of the simulation. Pressures are in millibars.

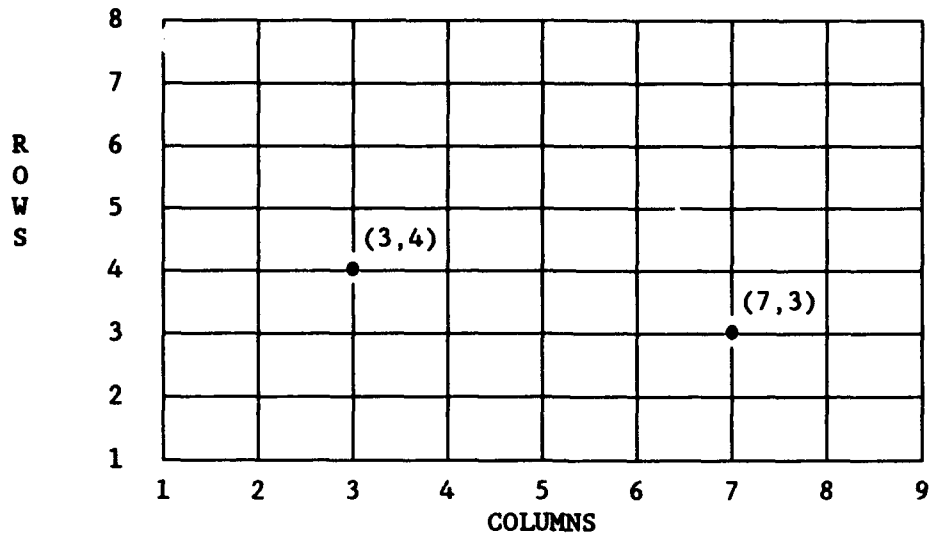

GRID CONVENTION

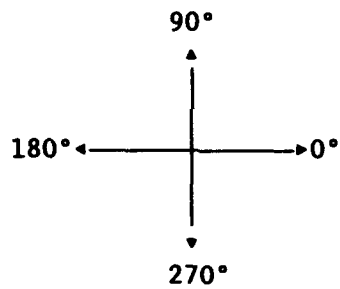

DIRECTION CONVENTION

NOTE: When grid information is entered in matrix form (as from a file), then the first line of data corresponds to ROW 8 on the grid above.

Figure 13-8. Orientation convention for the computational grid

PART V: HURWIN FILE DESCRIPTIONS

Introduction

48. The organization of files used in the HURWIN branch of the Spectral Wave Modeling module is shown in Figures 13-5 through 13-7. A list of the files (and related file numbers) is provided in Table 13-1. Reference numbers in the table correspond to file numbers given in the figures. In general, the creation, organization, and usage of almost all files in the CMS Spectral Wave Modeling module are transparent to the user. The module creates and organizes the files, prompting the user for information only when necessary. For reference, however, a brief description of the data and data format required by each file is provided in this section. Default values, available in HURWIN for some data fields, are given in parentheses.

File Descriptions and Data Formats

Snapshot Input File (snapin.hur)

49. The Snapshot Input File is one of the files built by the Input File-Building routine (Part IV). The file contains data needed to compute hurricane snapshots. RECORD 3 of this file takes two different forms, depending on the selection in GF-19, because of the additional parameters required when the general pressure profile is used.

a. RECORD 1, Namelist Format (NAME1)

- Field 1 - Desired printing option (0).
- Field 2 - Number of snapshots.
- Field 3 - System of units (OCEANWEA).

b. RECORD 2, Namelist Format (NAME2)

- Field 1 - Air-land temperature difference (0.0).
- Field 2 - Air-sea temperature difference (-2.0).
- Field 3 - Boundary layer height over water (500.0 m; 1,640.4 ft).
- Field 4 - Roughness length over land (0.08).
- Field 5 - Charnock's constant (0.035).
- Field 6 - Potential temperature (26.85 deg C; 80.33 deg F; 300.0 deg K).
- Field 7 - von Karman's constant (0.35).

Table 13-1

Summary of Files Used in HURWIN

<u>File Title</u>	<u>Name</u>	<u>Reference Number</u>
Snapshot Input File	snapin.hur	12
Hourly History Input File	histin.hur	16
Output Grid Parameters Input File	gridparm.hur	18
Land/Sea Table Input File	lndsea.hur	14
Version of "snap" Files	snap1.hur snap2.hur	21 22
Parameter File	file1.hur	9
Main File of File Names	filenmi.hur	8
Post-Processing File Names	filenmpst.hur	15
Job Control File To Run Wind Computational Programs	hurwin_run	10
Snapshot Wind Information File	fort.13	13
General Run Information from "snap"	fort.25	25
General Run Information from "hist"	fort.26	26
Initial Wind Field or Pressure on Fine Grid	wind01 or pres01	7
Initial Wind Field or Pressure on Coarse Grid	wind02 or pres02	8
Wind Field Output File	user-specified + ".win"	11
Wind Characteristics Output File	user-specified + ".sum"	9
Pressure Field Output File	user-specified + ".prs"	11

c. RECORD 3 (standard pressure profile, GF-19, option "1"), Namelist format (NAME3) (repeated for each snapshot)

- Field 1 - Storm name.
- Field 2 - Surface geostrophic wind speed.
- Field 3 - Surface geostrophic wind direction.
- Field 4 - North latitude of storm characteristic or average value).
- Field 5 - Track direction.
- Field 6 - Forward speed of storm.

- Field 7 - Pressure at storm eye.
- Field 8 - Pressure profile scale radius.
- Field 9 - Far field pressure.
- Field 10 - Number of wind computation cycles (800).
- Field 11 - Innermost grid spacing (2.0 km; 1.2 miles; 1.0 nm). Note this is equal to the innermost grid spacing used for computation (GF-21) only if NESTS = 7 (GF-20) (see Table 1, Cardone et al. 1994).
- Field 12 - Index to the number of active nests for computation (parameter INSIDE in Table 1, Cardone et al. 1994).
- Field 13 - Distance from axis to 0.5 surface geostrophic wind (0.0).
- Field 14 - Units for track direction (0).
- Field 15 - Pressure field quadrant indicator (0).
- Field 16 - Switch for creating pressure field output (0).

d. RECORD 3 (generalized pressure profile, GF-19, option "2"),
 Namelist format (NAME3A) (repeated for each snapshot)

- Field 1 - Storm name.
- Field 2 - Surface geostrophic wind speed.
- Field 3 - Surface geostrophic wind direction.
- Field 4 - North latitude of storm eye (characteristic or average value).
- Field 5 - Track direction.
- Field 6 - Forward speed of storm.
- Field 7 - Pressure at storm eye.
- Field 8 - Pressure profile scale radius, inner component.
- Field 9 - Pressure profile scale radius, outer component.
- Field 10 - Far field pressure.
- Field 11 - Number of wind computation cycles (3200).
- Field 12 - Innermost grid spacing (2.0 km; 1.2 miles; 1.0 nm). Note this is equal to the innermost grid spacing used for computation (GF-21) only if NESTS = 7 (GF-20) (see Table 1, Cardone et al. 1994).
- Field 13 - Index to the number of active nests for computation (parameter INSIDE in Table 1, Cardone et al. 1994).
- Field 14 - B coefficient for inner pressure component (1.0).

- Field 15 - B coefficient for outer pressure component (0.0).
- Field 16 - Pressure anomaly for inner pressure component (PFAR - EYPRES).
- Field 17 - Pressure anomaly for outer pressure component (0.0).
- Field 18 - Switch for creating pressure field output (0).

Hourly History Input File (histin.hur)

50. The Hourly History Input File is one of the files built by the Input File-Building routine (Part IV). The file contains data needed to compute the hourly wind histories.

a. RECORD 1, Namelist Format (NAME4)

- Field 1 - Storm name.
- Field 2 - Starting time.
- Field 3 - Time zone for starting time (1 = UTC).
- Field 4 - Desired output grid (0 = no; 1 = yes).
- Field 5 - Interval (hours) to print winds on grid.
- Field 6 - Output field option (1 = wind fields).
- Field 7 - Desired wind elevation (10.0 m; 33.0 ft).
- Field 8 - Desired output wind speed units ("knots").
- Field 9 - Desired output wind direction convention ("WIS").

b. RECORD 2, Namelist Format (NAME5)

- Field 1 - Roughness law coefficients (non-open water terrains, GF-14 for defaults).
- Field 2 - Number of measurement stations.
- Field 3 - Number of hours for history.

c. RECORD 3, Format (5I4,F6.1,1X,I3) Station Location and Data (repeated for each measurement station)

- Field 1 - Degrees of north latitude.
- Field 2 - Minutes of latitude.
- Field 3 - Degrees of west longitude.
- Field 4 - Minutes of longitude.
- Field 5 - Terrain code (see GF-57 for codes).
- Field 6 - Station height (10.0 m).
- Field 7 - Station number (for identification only).

- d. RECORD 4, Format (6I4,F8.4,2I4) Hourly History Data (repeated for each hour)

Field 1 - Degrees of north latitude, storm eye location.
Field 2 - Minutes of latitude, storm eye location.
Field 3 - Degrees of west longitude, storm eye location.
Field 4 - Minutes of longitude, storm eye location.
Field 5 - Sequence number of first snapshot to be used for this hour.
Field 6 - Sequence number of second snapshot wind field to be used for this hour (blank if no interpolation this hour).
Field 7 - Interpolation distance between first and second snapshots (blank if Field 6 is blank).
Field 8 - Clockwise rotation of snapshot (deg).
Field 9 - Printing flag (= 0 to suppress printing of the output grid wind field).

Output Grid Parameters Input File (gridparm.hur)

51. The Output Grid Parameters Input File is one of the files built by the Input File-Building routine (Part IV). It is optional and is needed only when an output grid is requested. The file contains data needed to define the output grid.

- a. RECORD 1, Format (4F6.1,F6.2,2I4)

Field 1 - North latitude for north edge of grid (deg).
Field 2 - North latitude for south edge of grid (deg).
Field 3 - West longitude for west edge of grid (deg).
Field 4 - West longitude for east edge of grid (deg).
Field 5 - Grid cell spacing (deg).
Field 6 - Number of rows (y-values or latitudes).
Field 7 - Number of columns (x-values or longitudes).

Land/Sea Table Input File (lndsea.hur)

52. The Land/Sea Table Input File is one of the files built by the Input File-Building routine (Part IV). The file contains data needed to define the type of land or water surface (terrain) at each point on the output grid. The file is needed only if an output grid is requested.

- a. RECORD 1, Format (78I1) (repeated for each row of the output grid, beginning with the most northerly)

- Field 1 - Terrain code for first (most westerly) grid point in row (see GF-57 for possible codes).
- Field 2 - Terrain code for second grid point in row.
- .
- .
- Field N - Terrain code for Nth grid point in row.

Version-of-"Snap" Files (snap1.hur and snap2.hur)

53. The Version-of-"Snap" Files are very short files created and deleted automatically each time HURWIN is run. Their only purpose is to indicate to program "snap" whether a coarse or fine output grid is to be run.

a. RECORD 1, Format (A5)

- Field 1 - Version of "snap" to be run (- snap1 for coarse grid; - snap2 for fine grid).

Parameter File (file1.hur)

54. The Parameter File is created by the Input File-Building routine. Values in the parameter file are used to dimension variables in HURWIN and its supporting programs. The programs use the FORTRAN command "INCLUDE" to include the Parameter File in the programs during compilation. The Parameter File contains a FORTRAN "PARAMETER" statement. The variables in the "PARAMETER" statement are defined as follows:

- IDMN - Number of columns (I values) in the output grid.
- JDMN - Number of rows (J values) in the output grid.
- IF - 1
- IA - 1
- KSST - 0
- MKST - 0
- NBPS - 0
- NDIF - 0 to suppress pressure field output; - 1 to activate.
- ITDM - Number of hours for history.
- NDMN - Number of measurement (gage) stations.
- MODEL - 3, specifies HURWIN model.
- INDM - 1
- MAXI - Number of columns (I values) in the output grid.
- MAXJ - Number of rows (J values) in the output grid.
- MAXHRS - Number of hours for time history.
- MAXSTA - Number of measurement (gage) stations.

Main File of File Names (filenmi.hur)

55. The Main File of File Names contains the name of the main input files. It also contains the file name of the "snap" FORTRAN program to be used. The format is as follows:

- a. RECORD 1, Free Format.
Field 1 - Snapshot input file name.
- b. RECORD 2, Free Format.
Field 1 - Hourly history input file name.
- c. RECORD 3, Free Format.
Field 1 - Output grid parameters file name.
- d. RECORD 4, Free Format.
Field 1 - Land/sea (terrain) table file name.
- e. RECORD 5, Free Format.
Field 1 - File name of the "snap" program to be used
(= 'snap_adc.f' for standard pressure profile;
= 'snap_hol.f' for generalized pressure profile).

Post-Processing File Name File (filenmpst.hur)

56. The Post-Processing File Name File contains the names of the output files from HURWIN. The format is as follows:

- a. RECORD 1, Free Format.
Field 1 - File name for wind characteristics output file
(used for creating time history plots and statistics).
- b. RECORD 2, Free Format.
Field 1 - Blank.
- c. RECORD 3, Free Format.
Field 1 - File name for wind field output file.

Job Control File To Run Wind Computational Programs (hurwin_run)

57. The file of job control language (SCRIPT file) used to run the wind computational programs is created automatically when HURWIN is run. It controls file handling and execution of the FORTRAN programs needed to run HURWIN. Because of its specialized nature, it is not discussed in detail here.

Snapshot Wind Information File (fort.13)

58. The Snapshot Wind Information File contains detailed information on each snapshot computed in program "snap." For each snapshot, the file includes parameters and the full wind field on the nested computational grid.

This file is created and deleted automatically when HURWIN is run. Because it is written in binary form, it is not discussed in detail in this report.

Initial Wind or Pressure Field on Fine Grid File (wind01 or pres01)

59. The Initial Wind or Pressure Field on Fine Grid File contains wind or pressure fields for each requested hour. They are computed using the user-specified grid spacing for the nested computational grid (specified in GF-21 for the innermost computational nest); but they are output in terms of the user-specified output grid. This file is created and deleted automatically when HURWIN is run and an output grid has been requested. Pressure fields are optional (GF-40).

- a. RECORD 1, Format (I10) (Records 1-3 are repeated for every hour requested in the hourly history)

Field 1 - Date-time for the wind field (YYMMDDHH).

- b. RECORD 2, Format (21F6.1) for wind speed; (21F6.3) for wind stress; (21F6.1) for pressure (repeated for successive rows in maximum groupings of 21 columns)

Field 1 - Wind speed, stress (u^2 ; see GF-32), or pressure at northwest corner of output grid (knots).

Field 2 - Wind speed, stress, or pressure at first point east of northwest corner of output grid.

- c. RECORD 3, Format (21F6.1) (repeated as with RECORD 2 for wind speed or stress; omitted for pressure)

Field 1 - Wind direction at northwest corner of output grid (deg; 0 deg - wind blowing toward east; 90 deg - wind blowing toward north; etc.; see Figure 13-8).

(same repetition as with RECORD 2)

Initial Wind or Pressure Field on Coarse Grid File (wind02 or pres02)

60. The Initial Wind or Pressure Field on Coarse Grid File contains wind or pressure fields for each requested hour. They are computed using an initial coarse spacing for the nested computational grid, which is preset in HURWIN (25-km spacing for the inner nest); but they are output in terms of the user-specified output grid. This file is created and deleted automatically when HURWIN is run and an output grid has been requested. The record structure and formats are identical to those for the Initial Wind or Pressure Field on Fine Grid. They are not repeated here.

Wind Field Output File (user specified + ".win")

61. The Wind Field Output File is the file of final hourly hurricane wind fields on the user-specified output grid. It is created in program "blend" by merging the initial wind fields computed on the coarse and fine grids onto the output grid. Winds from the fine grid are used in all areas of the output grid covered by the fine grid. Winds from the coarse grid are used for areas of the output grid (if any) which lie outside the fine grid coverage. Record structure and formats are identical to those for the initial wind fields on fine and coarse grids. They are not repeated here.

Wind Characteristics Output File (user specified + ".sum")

62. The Wind Characteristics Output File contains information on the hourly time history of winds from selected special output (measurement) stations. The number of stations and descriptive data for each selected station are described in questions GF-52 through GF-59. Records are organized as follows:

- a. RECORD 1 - Station 1, Hour 1
- b. RECORD 2 - Station 1, Hour 2
- c. RECORD 3 - Station 1, Hour 3
-
-
-
- n. RECORD n - Station 1, Hour NOHRS
- n+1. RECORD n+1- Station 2, Hour 1
- n+2. RECORD n+2- Station 2, Hour 2
-
-

Each record contains the following data:

RECORD n, Format (I10,2I5,2F6.1)

- Field 1 - Date (YYMMDDHH).
- Field 2 - Hour.
- Field 3 - Sequential station number.
- Field 4 - Wind speed (knots).
- Field 5 - Wind direction (degrees, see Figure 13-8).

Pressure Field Output File (user specified + ".prs")

63. The Pressure Field Output File is the file of final hourly hurricane pressure fields on the user-specified output grid. It is created in program "blendp" by merging the initial pressure fields computed on the coarse and fine grids onto the output grid. Pressures from the fine grid are used in all areas of the output grid covered by the fine grid. Pressures from the coarse grid are used for areas of the output grid (if any) which lie outside the fine grid coverage. Record structure and formats are identical to those for the initial pressure fields on fine and coarse grids. They are not repeated here.

PART VI: EXAMPLE APPLICATION

64. An example application is presented in this section to illustrate the use of the HURWIN model, including input files and model output. The example also serves as a benchmark against which future versions of the model can be checked.

65. The example is based on the passage of a typhoon near the island of Guam in the south Pacific Ocean (Northern Hemisphere). Typhoon Russ impacted Guam during December of 1990. The basic snapshot information for Typhoon Russ was developed by WIS from the 1990 Joint Typhoon Warning Center publication, *1990 Annual Tropical Cyclone Report (NOCC/JTWC 1990)*.

66. The fine mesh computational grid was run with a grid spacing of 10 km on the innermost nest. An output grid was defined with 13 rows, 13 columns, and a grid spacing of 0.1 deg. The grid boundaries are 12.9-14.1 deg north latitude and 214.9-216.1 west longitude (143.9-145.1 deg east longitude). The grid encompassed the island of Guam. To represent the island and surrounding reef areas, three points on the grid were defined as "woods" (or land) and five points were defined as "lake." While the "lake" term may seem unusual for this application, the corresponding surface roughness values give a rough approximation of the actual situation. The remaining grid points were defined as "open water." Input files for simulating 2 hr (not consecutive) during the passage of Typhoon Russ are given in Figure 13-9.

67. During the first hour simulated (1500 hr on 20 December 1990) Typhoon Russ was nearly due south of Guam. Maximum wind speed on the output grid exceeded 95 mph. Wind speed contours are shown in Figure 13-10. Because the storm center is relatively near (but outside) the grid boundary, wind contours have a noticeable curvature. Wind speeds were reduced significantly at Guam because of the increased roughness specified for those grid points. Wind speed and direction across the grid, as given in the output file "guam.win," are tabulated in Figure 13-11.

68. The second hour simulated is 0000 hr on 21 December 1990. (In a normal HURWIN run, wind fields would be simulated every hour). The storm center had moved to a position due west of Guam. The center is more than 1 deg west of the western boundary of the output grid. Maximum wind speed on the grid is 58.6 mph. Wind speed contours are reasonably straight across the grid, with the exception of distortions around Guam (Figure 13-12). Tabulated wind speeds and directions are given in Figure 13-13.

SNAPIN.HUR Input File

&NAME1 IB=0, NZ=3, UNITS = ' METRIC', &END

&NAME2 DTH=0.0, -2.0, HH=500.0, ZOLAND=8.0E-02, GARR=1.44E-02, PTH=26.85, K35=0.35, &END

&NAME3 STORM='russ', SGW=9.0, AN1=161.0, EYELAT=12.0, EYLONG=215.0, DIREC=289.0, SPEED=6.17333,
EYPRES=924.0, RADIUS=37.04, 3*0.0, PFAR=1012.0, NM=800, DX=10.0, ST12=0.0, ITRACK=0, IQUAD=0, &END

&NAME3 STORM='russ', SGW=9.0, AN1=161.0, EYELAT=12.0, EYLONG=215.0, DIREC=289.0, SPEED=7.202222,
EYPRES=924.0, RADIUS=37.04, 3*0.0, PFAR=1012.0, NM=800, DX=10.0, ST12=0.0, ITRACK=0, IQUAD=0, &END

&NAME3 STORM='russ', SGW=9.0, AN1=161.0, EYELAT=12.0, EYLONG=215.0, DIREC=289.0, SPEED=8.231111,
EYPRES=924.0, RADIUS=37.04, 3*0.0, PFAR=1012.0, NM=800, DX=10.0, ST12=0.0, ITRACK=0, IQUAD=0, &END

HISTIN.HUR Input File

&NAME4 STORM='russ', ISTART=90122015, ZONE='UTM', ICNVRT=1, NPRT=1, IFIELD=1, GRIDHT=10.0, &END

&NAME5 ZCOEFF=0.0, 3.7E-03, 1.5E-02, 2*0.0, 4.0E-02, 2*0.0, 0.16, 2*0.0, 0.32, 2*0.0, 1.28, NOGAGES=0,
NOHRS=2, &END

12 30 215 9 1 2 0.3333 0 0
12 58 217 22 2 2 0.8333 0 0

GRIDPARM.HUR Input File

14.1 12.9 216.1 214.9 0.10 13 13

LNDSEA.HUR Input File

11111111111111111111
11111111111111111111
11111111111111111111
11111111111111111111
11111111111111111111
11111111111111111111
11111111251111111111
11111112511111111111
11111112511111111111
11111112211111111111
11111111111111111111
11111111111111111111
11111111111111111111

Figure 13-9. Example data files, Typhoon Russ

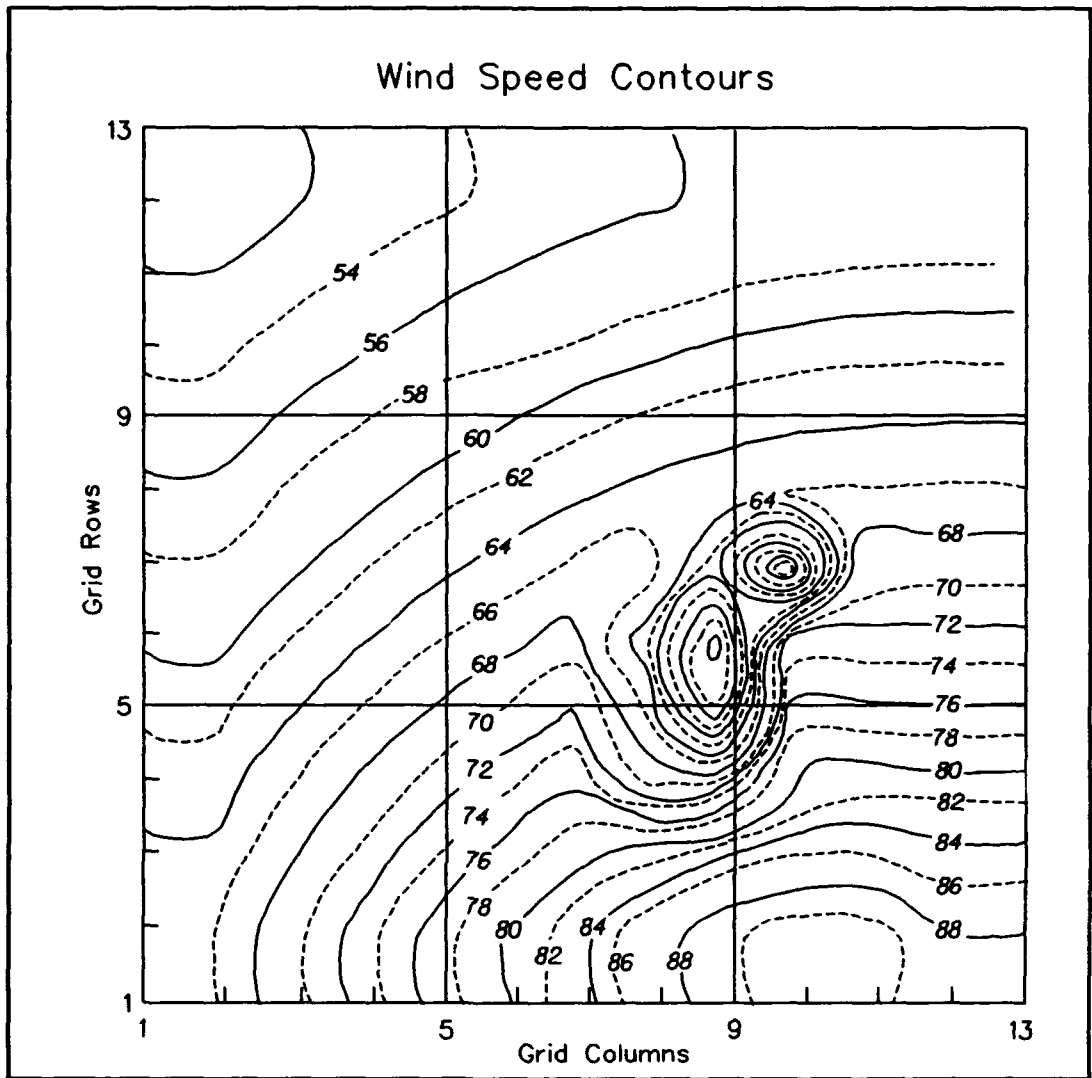

Figure 13-10. Wind speed contours, 1500 hr, 20 Dec 90

48.6	49.5	50.4	51.2	52.0	52.7	53.4	54.0	54.4	54.8	55.0	55.1	55.0
49.8	50.8	51.8	52.7	53.6	54.4	55.2	55.8	56.3	56.7	56.9	57.1	56.9
51.0	52.1	53.2	54.2	55.2	56.1	57.0	57.7	58.3	58.7	59.0	59.1	58.9
52.3	53.5	54.7	55.8	57.0	58.0	59.0	59.8	60.5	61.0	61.3	61.4	61.1
53.6	54.9	56.3	57.6	58.9	60.1	61.2	62.1	62.9	63.5	63.8	63.9	63.5
55.0	56.5	58.0	59.5	61.0	62.2	63.6	64.6	65.5	66.1	66.4	66.5	66.1
56.4	58.1	59.8	61.5	63.2	64.7	66.2	67.4	61.2	49.3	69.6	69.6	69.0
57.9	59.7	61.7	63.6	65.6	67.2	69.0	62.9	51.2	72.4	72.8	72.8	72.0
59.2	61.4	63.6	65.9	68.1	70.2	72.2	66.2	54.2	76.4	76.8	76.6	75.7
60.5	63.0	65.6	68.2	70.8	73.3	75.7	69.8	71.4	80.9	81.3	80.8	79.5
61.7	64.5	67.5	70.5	73.6	76.7	79.6	82.3	84.5	85.9	86.1	84.9	83.0
62.8	65.9	69.2	72.7	76.4	80.2	83.8	87.1	89.7	91.0	90.4	88.0	85.3
63.6	67.0	70.7	74.7	79.0	83.5	88.0	92.0	94.8	95.1	92.3	88.3	84.9
254.7	253.0	251.3	249.2	247.2	245.0	242.7	240.2	237.7	235.0	232.3	229.5	226.7
256.6	254.8	253.0	250.8	248.7	246.3	243.8	241.1	238.4	235.6	232.6	229.6	226.6
258.5	256.7	254.8	252.5	250.3	247.7	245.0	242.1	239.2	236.1	232.9	229.6	226.3
260.6	258.7	256.7	254.3	252.0	249.2	246.3	243.2	240.0	236.6	233.1	229.6	225.9
262.9	260.9	258.9	256.4	253.9	250.8	247.8	244.4	240.9	237.1	233.3	229.3	225.3
265.3	263.2	261.2	258.5	255.9	252.6	249.3	245.5	241.7	237.6	233.4	229.0	224.6
268.0	265.9	263.8	261.0	258.3	254.7	251.1	246.9	246.1	247.6	233.2	228.3	223.3
270.7	268.6	266.5	263.5	260.6	256.8	252.9	251.6	253.1	238.4	233.1	227.5	222.0
273.9	271.8	269.4	266.6	263.3	259.4	254.9	253.2	253.8	238.6	232.4	226.0	219.6
277.1	275.2	272.8	269.9	266.5	262.3	257.4	255.0	248.6	238.5	231.2	223.6	216.0
280.8	278.9	276.5	273.7	270.1	265.7	260.3	253.9	246.4	238.0	229.0	219.5	210.6
284.6	282.9	280.7	277.9	274.3	269.7	263.8	256.4	247.3	236.7	224.8	212.7	201.9
288.8	287.4	285.3	282.7	279.2	274.5	268.2	259.5	248.0	233.8	217.6	201.7	188.8

Figure 13-11. Output wind speeds and directions,
1500 hr, 20 Dec 90

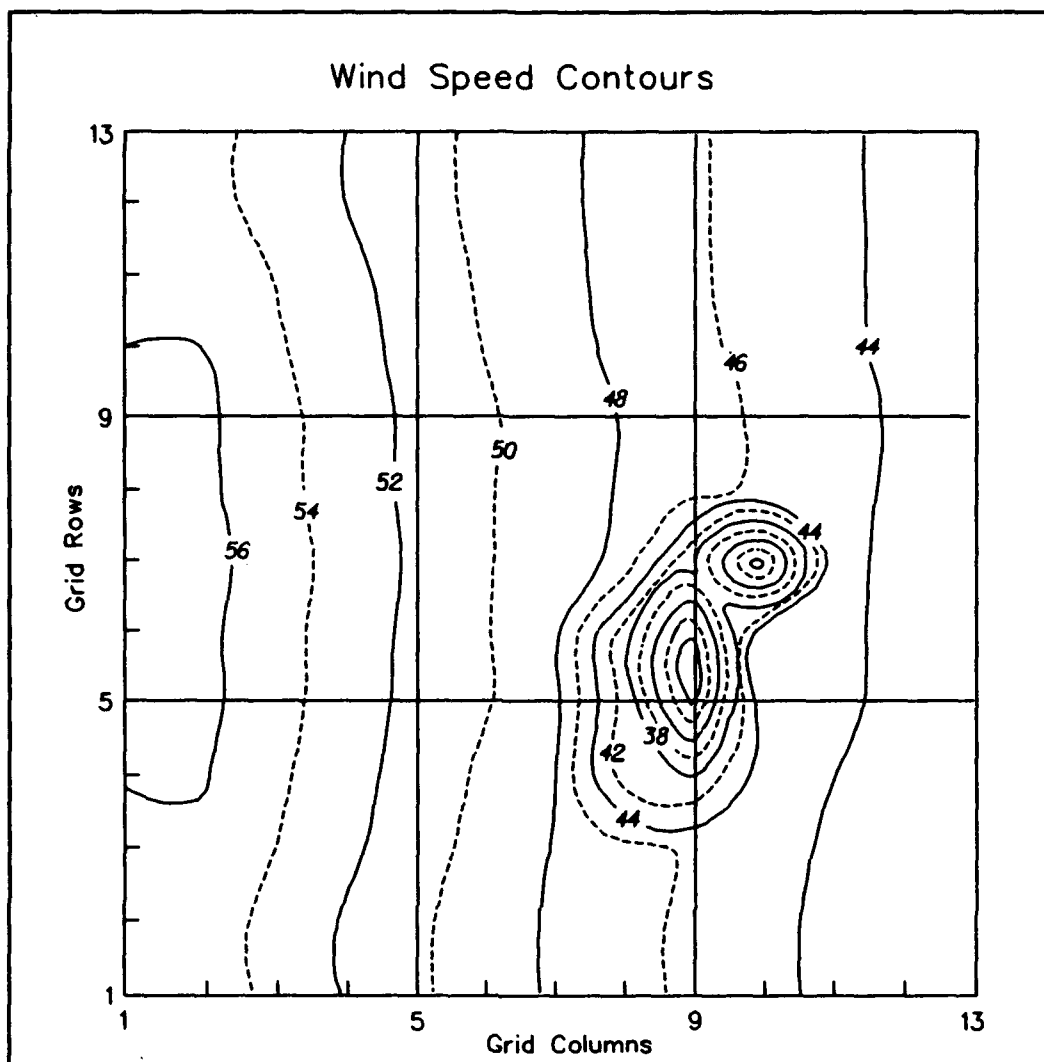

Figure 13-12. Wind speed contours, 0000 hr, 21 Dec 90

55.1 53.9 52.7 51.6 50.4 49.3 48.2 47.2 46.2 45.2 44.3 43.4 42.5
 56.1 54.8 53.5 52.2 50.9 49.7 48.6 47.5 46.5 45.4 44.5 43.6 42.7
 57.1 55.6 54.1 52.7 51.3 49.9 48.6 47.6 46.5 45.4 44.5 43.6 42.7
 57.6 56.0 54.4 53.0 51.5 50.1 48.8 47.7 46.7 45.6 44.6 43.6 42.7
 58.2 56.5 54.8 53.2 51.7 50.4 49.2 48.0 46.9 45.8 44.7 43.8 42.9
 58.3 56.5 54.8 53.2 51.7 50.3 49.0 47.9 46.7 45.6 44.6 43.7 42.8
 58.6 56.8 55.0 53.4 51.8 50.3 48.8 47.7 40.7 31.1 44.5 43.6 42.6
 58.3 56.5 54.8 53.2 51.6 50.2 48.8 41.8 31.9 45.5 44.5 43.5 42.6
 58.3 56.5 54.8 53.1 51.5 50.2 48.9 41.8 31.9 45.5 44.4 43.5 42.6
 57.8 56.1 54.4 52.8 51.2 49.7 48.2 41.3 40.2 45.0 44.0 43.1 42.2
 57.4 55.7 54.0 52.4 50.9 49.3 47.9 46.8 45.7 44.7 43.7 42.8 41.9
 56.7 55.0 53.4 51.8 50.4 49.0 47.7 46.6 45.6 44.5 43.5 42.6 41.7
 55.9 54.2 52.6 51.1 49.7 48.4 47.1 46.1 45.0 44.0 43.0 42.2 41.3
 191.9 189.8 187.8 186.1 184.4 183.1 181.7 180.6 179.4 178.2 177.2 176.3 175.4
 189.0 187.0 185.0 183.4 181.8 180.5 179.2 178.2 177.1 175.9 174.9 174.2 173.4
 185.7 183.8 181.9 180.3 178.7 177.4 176.1 175.2 174.2 173.2 172.3 171.6 170.9
 181.8 180.0 178.2 176.8 175.4 174.2 173.0 172.2 171.3 170.4 169.6 169.0 168.4
 177.5 175.8 174.3 173.0 171.8 170.9 170.0 169.2 168.5 167.7 167.0 166.5 166.0
 172.2 170.9 169.6 168.7 167.7 167.0 166.3 165.7 165.1 164.5 164.0 163.6 163.2
 166.7 165.7 164.9 164.2 163.5 163.0 162.4 162.0 165.9 172.4 160.8 160.6 160.3
 160.3 159.9 159.5 159.3 159.0 158.8 158.5 162.5 169.2 157.8 157.6 157.6 157.5
 153.9 154.0 154.1 154.3 154.4 154.5 154.6 158.8 165.7 154.5 154.5 154.5 154.6
 147.1 147.7 148.4 149.0 149.5 150.0 150.4 154.8 155.0 150.9 151.1 151.3 151.5
 140.5 141.6 142.7 143.7 144.7 145.4 146.1 146.5 146.8 147.2 147.6 148.0 148.3
 133.8 135.4 136.9 138.3 139.7 140.8 141.8 142.3 142.9 143.6 144.1 144.6 145.1
 127.7 129.5 131.4 133.1 134.9 136.6 137.7 138.4 139.2 140.0 140.8 141.4 142.1

Figure 13-13. Output wind speeds and directions,
0000 hr, 21 Dec 90

REFERENCES

- Abel, C. E., Tracy, B. A., Vincent, C. L., and Jensen, R. E. 1989. "Hurricane Hindcast Methodology and Wave Statistics for Atlantic and Gulf Hurricanes from 1956-1975," WIS Report 19, US Army Engineer Waterways Experiment Station, Vicksburg, MS.
- Arya, S. P. S. 1977. "Suggested Revisions to Certain Boundary Layer Parameterization Schemes Used in Atmospheric Circulation Models," Monthly Weather Review, Vol 105, pp 215-227.
- Black, M. L., and Willoughby, H. E. 1992. "The Concentric Eyewall Cycle of Hurricane Gilbert," Monthly Weather Review, Vol 120, pp 947-957.
- Blackadar, A. K., and Tennekes, H. 1968. "Asymptotic Similarity in Neutral Barotropic Planetary Boundary Layers," Journal of Atmospheric Sciences, Vol 25, pp 1015-1020.
- Cardone, V. J. 1969. "Specification of the Wind Distribution in the Marine Boundary Layer for Wave Forecasting," TR-69-1, Geophysical Sciences Laboratory, New York University, New York, NY.
- Cardone, V. J., Cox, A. T., Greenwood, J. A., and Thompson, E. F. 1994. "Upgrade of Tropical Cyclone Surface Wind Field Model," Miscellaneous Paper CERC-94-xx (in publication), US Army Engineer Waterways Experiment Station, Vicksburg, MS.
- Cardone, V. J., Greenwood, C. V., and Greenwood, J. A. 1992. "Unified Program for the Specification of Hurricane Boundary Layer Winds Over Surfaces of Specified Roughness," Contract Report CERC-92-1, US Army Engineer Waterways Experiment Station, Vicksburg, MS.
- Chow, S. 1971. "A Study of the Wind Field in the Planetary Boundary Layer of a Moving Tropical Cyclone," M.S. thesis, Dept. of Meteorology and Oceanography, New York University, New York, NY.
- Deardorff, J. W. 1972. "Parameterization of the Planetary Boundary Layer for Use in General Circulation Models," Monthly Weather Review, Vol 100, pp 93-106.
- Garratt, J. R., Jr. 1977. "Review of Drag Coefficients Over Oceans and Continents," Monthly Weather Review, Vol 105, pp 915-929.
- Holland, G. J. 1980. "An Analytic Model of the Wind and Pressure Profiles in Hurricanes," Monthly Weather Review, Vol 108, pp 1212-1218.
- NOCC/JTWC. 1990. "1990 Annual Tropical Cyclone Report," NOCC/JTWC, COMNAVMAR, PSC 489, Box 12, FPO AP 96540-0051, 278 pp.
- Smagorinsky, J. 1963. "General Circulation Experiments with the Primitive Equations; I. The Basic Experiment," Monthly Weather Review, Vol 91, pp 99-164.

Thompson, E. F., and Leenknecht, D. A. 1994. "Wind Estimation for Coastal Modeling Applications," Journal of Coastal Research (in publication).

Willoughby, H. E. 1990. "Temporal Changes fo the Primary Circulation in Tropical Cyclones," Journal of Atmospheric Sciences, Vol 47, pp 242-264.

Zilitinkevich, S. S. 1969. "On the Computation of the Basic Parameters of the Interaction Between the Atmosphere and the Ocean," Tellus, Vol 21, pp 17-24.

CHAPTER 14

WICM: A WAVE-INDUCED CURRENT MODEL THEORY AND PROGRAM DOCUMENTATION

PART I: INTRODUCTION

1. This chapter documents the Wave-Induced Current Model (WICM). WICM is a two-dimensional, depth-averaged model for computing wave-induced currents and water surface setup. The model solves finite difference approximations of the Navier-Stokes (continuity and horizontal momentum) equations for water surface displacement (S) and unit flow rate components (U and V). WICM is a two-dimensional model; therefore, velocities are treated as depth-averaged quantities (i.e., velocities are constant through the water column in both magnitude and direction). WICM can simulate flow fields induced by waves, winds, river inflows/outflows, and tidal forcing. This finite difference model is developed in boundary-fitted (curvilinear) coordinates.

2. WICM is a specialized version of the curvilinear long wave hydrodynamic model CLHYD documented in Chapter 6. In addition to the forcing mechanisms in CLHYD, WICM includes wave stresses (gradients in radiation stress) caused by breaking waves to force nearshore circulation and wave setup. To calculate radiation stress, WICM requires input wave fields from either a monochromatic (Regional Coastal Processes Wave Propagation model (RCPWAVE), Chapter 5) or spectral (Steady-State Spectral Wave Energy Propagation Model (STWAVE), Chapter 8) wave model.

3. The user must have a thorough understanding of the model's capabilities and limitations before applying it to a particular study. WICM does not provide the "total solution" to any given hydrodynamic problem. The user must ensure that limitations imposed by the governing equations (e.g., linear wave theory) are applicable to the problem being investigated. Furthermore, the model should not be treated as a "black box"; the engineer or scientist must check computed results and assess their reasonableness.

4. This chapter is divided into five sections: Part II presents the governing equations and computational scheme used in the model, Part III defines the input data formats, Part IV discusses the model's input data requirements, and Part V contains several illustrative examples.

PART II: WICM MODEL FORMULATION

5. The concept of radiation stress, introduced by Longuet-Higgins and Stewart (1962, 1963, 1964), has been used to model wave-induced currents and setup in one dimension (Bowen 1969; Longuet-Higgins 1970a, b; and Thornton 1970) and two dimensions (Keely and Bowen 1977; Ebersole and Dalrymple 1979; Vemulakonda 1984; and Wind and Vreugdenhil 1986). Radiation stress is a measure of the momentum flux in the wave field. Gradients in radiation stress due to decay of the wave height (wave breaking) exert a stress on the water column. This wave stress transfers momentum from the wave field to the longshore and cross-shore flow field. This chapter documents the two-dimensional WICM model for simulating wave-induced currents and water surface setup. In two-dimensional models, the governing three-dimensional equations are integrated over the water depth to yield vertically averaged velocities; that is, velocities that are constant through the water column.

Assumptions and Limitations

6. Proper application of the model requires a clear understanding of the physical processes occurring in a study area and comprehension of the capabilities of the model to simulate those processes. The limitations of a model define its range of applicability. In particular, WICM is a two-dimensional depth-averaged model; therefore, the model should be applied only where the water column is well mixed and no significant vertical variations occur. Hydrostatic pressure conditions are assumed in the model formulation. Thus, the model should be applied only where there is no significant vertical acceleration of the water.

7. Responsible application of WICM requires knowledge of the model's capabilities as well as its limitations. The model should be applied such that time and length scales associated with breaking short-wave and long-wave (for simulations including tide) processes can be resolved. WICM is most applicable for open coast situations where the primary focus is surf zone circulation. Assumptions in the model include linear wave theory (calculation of radiation stress), no wave-current interaction, linear bottom friction, and no significant velocity variations over depth.

8. Presently, the model lacks a flood/dry capability and cannot treat submerged or overtopping barriers. A thorough comprehension of the physical processes simulated by the model is necessary to ensure that the model is applied to appropriate problems, that it is applied correctly, and that accurate results are produced.

9. A discussion of the hydrodynamic equations used in WICM is provided in the following section. It is recommended that the reader refer to Horikawa (1988) for a detailed discussion of coastal hydrodynamics.

Governing Equations

10. The hydrodynamic equations used in WICM are derived from the classical Navier-Stokes equations formulated in a Cartesian coordinate system (Figure 14-1). If vertical water accelerations are assumed to be small compared with gravitational acceleration (hydrostatic pressure conditions exist) and the fluid is homogeneous, the depth-averaged approximation is appropriate and yields the following two-dimensional form of the governing equations:

$$\frac{\partial U}{\partial t} + \frac{\partial}{\partial x} \left(\frac{UU}{H} \right) + \frac{\partial}{\partial y} \left(\frac{UV}{H} \right) + gH \frac{\partial S}{\partial x} - fV - \frac{\tau_{xx}}{\rho} - \frac{\tau_{yx}}{\rho} + \frac{\tau_{Bx}}{\rho} + A_H \left(\frac{\partial^2 U}{\partial x^2} + \frac{\partial^2 U}{\partial y^2} \right) = 0 \quad (14-1)$$

$$\frac{\partial V}{\partial t} + \frac{\partial}{\partial x} \left(\frac{UV}{H} \right) + \frac{\partial}{\partial y} \left(\frac{VV}{H} \right) + gH \frac{\partial S}{\partial y} + fU - \frac{\tau_{xy}}{\rho} - \frac{\tau_{yy}}{\rho} + \frac{\tau_{By}}{\rho} + A_H \left(\frac{\partial^2 V}{\partial x^2} + \frac{\partial^2 V}{\partial y^2} \right) = 0 \quad (14-2)$$

$$\frac{\partial S}{\partial t} + \frac{\partial U}{\partial x} + \frac{\partial V}{\partial y} = 0 \quad (14-3)$$

I II III IV V VI

where

- U, V - unit flow rate components in the x- and y-directions, respectively (discharge per unit width)
- t, x, y - independent space and time variables
- H - total water depth ($h+S$)
- h - static water depth measured from the same vertical datum
- S - water surface displacement measured relative to an arbitrary vertical datum

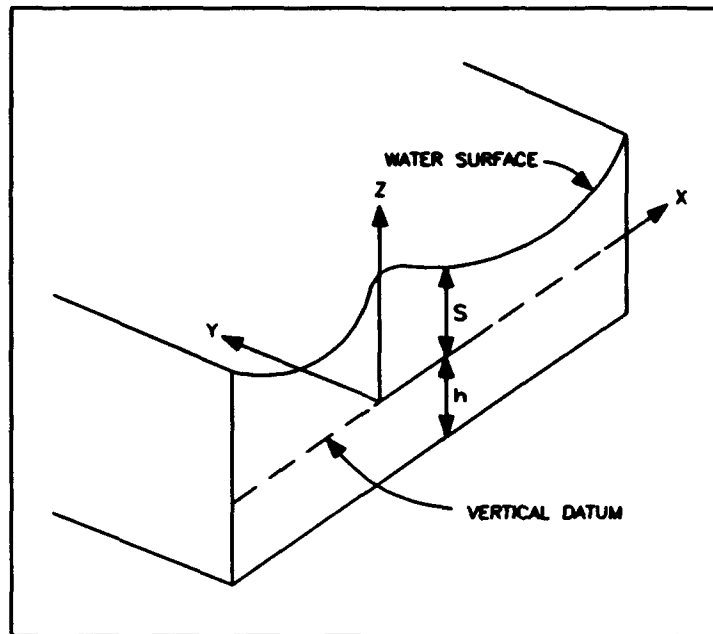

Figure 14-1. Definition sketch for Cartesian coordinate system

- g - gravitational acceleration
- f - Coriolis parameter
- τ_{xx}, τ_{yy} - external surface shear stresses, such as wind stress, in the x- and y-directions, respectively
- ρ - fluid density (assumed to be constant)
- τ_{wx}, τ_{wy} - wave stress (gradients in radiation stress), in the x- and y-directions, respectively
- τ_{Bx}, τ_{By} - bottom friction components in the x- and y-directions, respectively
- A_H - generalized diffusion coefficient

Equations 14-1, 14-2, and 14-3 represent the x-momentum, y-momentum, and continuity equations, respectively.

11. A detailed discussion of the Navier-Stokes equations with a rigorous derivation of each term is found in Harris and Bodine (1977). Wave stress and friction terms are derived in Longuet-Higgins (1970a, b). A brief discussion of the physical significance of the six groups of terms in Equations 14-1 through 14-3 is given in Table 14-1 and below. The Roman numerals below correspond to those in Equations 14-1 through 14-3:

Table 14-1

Description of Terms in the Governing Equations

Term	Definition and Discussion
$\frac{\partial U}{\partial t}, \frac{\partial V}{\partial t}$	Change of the vertically averaged flow per unit width with respect to time. Change may result from temporal acceleration of the mean flow.
$gH \frac{\partial S}{\partial x}, gH \frac{\partial S}{\partial y}$	Pressure gradient terms; describes the slope of the water surface; principal driving force of fluid flow.
τ_{bx}, τ_{by}	Bottom friction terms; stress of the fluid layer against the bottom boundary; serves as an energy dissipator.
fU, fV	Coriolis terms; accounts for the effect of the Earth's rotation.
$\frac{\partial}{\partial x} \left(\frac{UU}{H} \right)$	Advective (inertia) terms; describes the movement of water due to the fluid motion itself.
τ_{ax}, τ_{ay}	External shear stresses (such as the wind); any forcing function that serves to drive the fluid motion.
τ_{wx}, τ_{wy}	Wave stresses; forcing by gradients in radiation stress caused by wave breaking.
$A_H \left(\frac{\partial^2 U}{\partial x^2} + \frac{\partial^2 U}{\partial y^2} \right)$	Horizontal diffusion of momentum; describes the diffusion of momentum due to fluid motion; A_H is sometimes referred to as the eddy viscosity.
$\frac{\partial S}{\partial t}$	Change in water level with respect to time.
$\frac{\partial U}{\partial x}, \frac{\partial U}{\partial y}$	Rate at which water is converging or diverging horizontally at a given point (x,y) in space.

- I. Local flow acceleration (i.e., local variation of momentum with respect to time).
- II. Transport of momentum by advection (i.e., spatial acceleration).
- III. Barotropic pressure forces and conservation of mass.
- IV. Momentum sources and sinks due to Coriolis force, surface wind stress, and wave stress.
- V. Momentum sink due to bed friction.
- VI. Horizontal diffusion of momentum.

12. Various formulations of the terms in the governing equations are permissible. The expressions for bottom friction, diffusion, wind stress, wave stress, and the Coriolis coefficient employed in WICM are given below:

Bottom friction

13. The bottom shear stress impeding fluid motion is expressed in terms of a linear friction law (Longuet-Higgins 1970a):

$$\tau_{Bx} = \rho C_f \langle |u_{orb}| \rangle U \quad (14-4)$$

$$\tau_{By} = \rho C_f \langle |u_{orb}| \rangle V \quad (14-5)$$

where

C_f = constant friction factor (order 0.01)

$\langle |u_{orb}| \rangle$ = absolute value of the wave orbital velocity at the bottom, averaged over one wave period

From linear wave theory, the absolute value of the wave orbital velocity at the bottom, averaged over one wave period, is given by:

$$\langle |u_{orb}| \rangle = \frac{2 H_s}{T \sinh(k |H_s|)} \quad (14-6)$$

where

H_s = wave height

T = wave period

k = wave number

Equations 14-4 through 14-6 are based on the assumption that the velocity components U and V are small compared with the wave orbital velocity.

Diffusion coefficient

14. The diffusion coefficient A_H is treated as a constant in WICM and describes the rate of diffusion of momentum due to fluid motion. A_H is a function of the grid spacing with typical values of 0.0 to 1.0 m²/sec. Due to the current representation of the advective terms in WICM, results are not extremely sensitive to A_H .

Wind stress coefficient

15. Wind stress τ_s is formulated as:

$$\tau_s = \rho_{air} C_D |W|W \quad (14-7)$$

where ρ_{air} is air density, C_D is the wind drag coefficient determined from Garratt's equation (Garratt 1977):

$$C_D = \frac{(0.75 + 0.067\omega)}{1000}, \quad (14-8)$$

where ω is the resultant wind speed (meters/second) at 10 m above the water surface, and W is the wind velocity.

Wave stress

16. Wave stress τ_w is formulated in terms of gradients in radiation stress:

$$\tau_{wx} = - \frac{\partial S_{xx}}{\partial x} - \frac{\partial S_{xy}}{\partial y} \quad (14-9)$$

$$\tau_{wy} = - \frac{\partial S_{xy}}{\partial x} - \frac{\partial S_{yy}}{\partial y} \quad (14-10)$$

where S_{xx} , S_{xy} , and S_{yy} are components of radiation stress, defined as:

$$S_{xx} = E [n (\cos^2(\alpha) + 1.0) - 0.5] \quad (14-11)$$

$$S_{xy} = E n \cos(\alpha) \sin(\alpha) \quad (14-12)$$

$$S_{yy} = E [(2n - 0.5) \sin^2(\alpha) + (n - 0.5) \cos^2(\alpha)] \quad (14-13)$$

where E is wave energy, n is the ratio of group to phase velocity, and α is the local wave direction. Wave energy is calculated from linear wave theory using monochromatic wave input (from RCPWAVE) as:

$$E = 0.125 \rho g (H_p)^2 \quad (14-14)$$

where H_p is significant wave height, and using spectral wave input (from STWAVE) as:

$$E = 0.0625 \rho g (H_{m0})^2 \quad (14-15)$$

where H_{m0} is the energy-based, zero-moment wave height. Further details on the calculation of wave stress based on radiation stress are given in Longuet-Higgins (1970a).

Coriolis coefficient

17. The Coriolis term accounts for the fact that the Earth is rotating, whereas the coordinate frame of the computations is fixed. The Coriolis parameter f is expressed as:

$$f = 2\nu \sin \lambda \quad (14-16)$$

where ν is the angular speed of the Earth's rotation (7.292×10^{-5} rad/sec) and λ is the latitude of the study area. The extent of nearshore current problems is usually small enough that the Coriolis term may be neglected.

18. This completes the basic model formulation. If further details are desired, the reader should refer to Roache (1976) or Horikawa (1988).

Grid Systems

19. The governing equations (Equations 14-1, 14-2, and 14-3) that describe the physical processes associated with nearshore circulation contain partial derivatives with respect to time and space. Model WICM uses mathematical (finite difference) approximations to represent these continuous equations. The continuum is, therefore, represented by discrete points in time and space. Discretization of the horizontal plane is accomplished via a computational grid composed of a lattice network of cells. Each cell has certain flow field parameters associated with it. In the case of WICM, the water surface elevation is defined at the center of each cell and the unit flow rate components are defined on the cell faces. All information required as input to the model, including water depths and external forces (such as wind), is also defined at each cell center.

20. WICM is capable of using a uniform Cartesian grid, a stretched Cartesian grid, or a general curvilinear grid (Figures 14-2 through 14-4). Each of these grid types provides a successively more accurate representation of the modeled area; however, the complexity of the governing equations increases with each successive grid type. The grid type for WICM must match the grid type used by the wave model providing the input wave field for wave stress calculations (uniform Cartesian grid (RCPWAVE and STWAVE)). The stretched Cartesian and general curvilinear grid options in WICM are reserved for possible future applications.

21. Uniform Cartesian grids simply have cells of equal size in the x-direction and equal size in the y-direction. The advantages of using this type of grid are: (a) the simplicity of generating a grid; (b) the simplicity of formulating the governing equations; (c) the computational requirements are minimized because there are fewer terms in the governing equations; and (d) the uniform grids have been widely used and thoroughly tested.

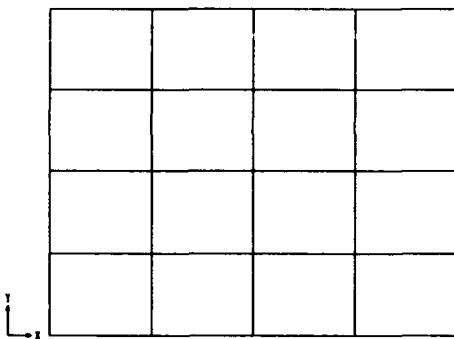

Figure 14-2. Uniform Cartesian grid

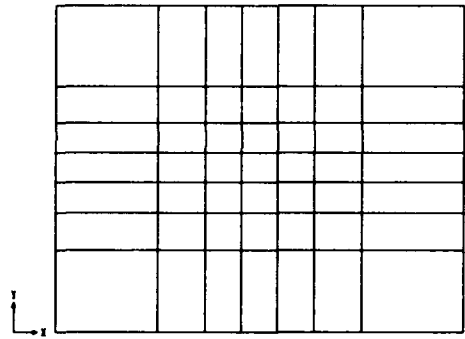

Figure 14-3. Stretched Cartesian grid

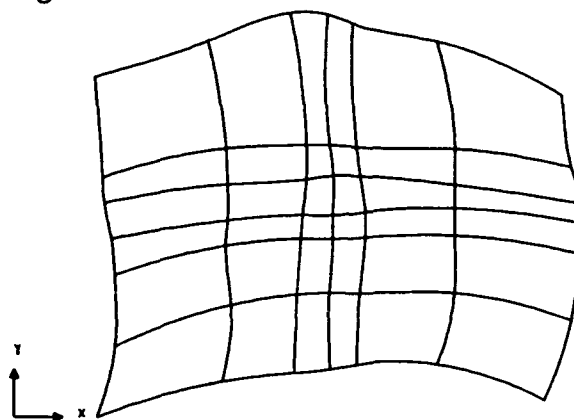

Figure 14-4. General curvilinear grid

Disadvantages of using a uniform Cartesian grid include: (a) inability to increase grid resolution in areas of interest; (b) usually uneconomical to use a fine-resolution grid throughout entire area; and (c) inability to efficiently resolve an irregular shoreline thus requiring "stair-stepping," which can lead to computational inaccuracies (Weare 1979).

22. Stretched Cartesian grids are flexible enough to increase grid resolution and, therefore, provide a more economical representation of an area than a uniform Cartesian grid. In other words, the number of grid cells required to represent an area can be reduced by using a stretched grid, which in turn reduces computational costs. However, the user must also consider that the number of terms in the governing equations increases when going from a uniform to a stretched grid.

23. Neither the uniform nor the stretched Cartesian grids can accurately depict irregular shorelines and must therefore resort to "stair-stepping." However, nonorthogonal curvilinear (boundary-fitted) grids can be generated to conform to bathymetric features and provide a more accurate means of representing a specific study area (Figure 14-4). These grids can be generated using a numerical grid generator such as program EAGLE (Thompson, Warsi, and Mastin 1985), which has the flexibility to concentrate grid lines in shallow/deep areas or in areas where the bathymetric gradients are great. With the increase in accuracy and adaptability comes increased complexity of the governing equations and the associated computational costs. In addition, general curvilinear grids are complex networks and are therefore more difficult to generate. However, increased accuracy and adaptability are often necessary to adequately represent features in coastal areas.

General curvilinear grid

24. For areas having irregular geometries, WICM is capable of using a nonorthogonal curvilinear grid. Thompson (1983) developed a method for generating two-dimensional boundary-fitted grids by solving elliptic equations. These equations relate the nonorthogonal curvilinear coordinate system in the physical plane (x,y) with a uniformly spaced coordinate system in the transformed plane (ξ,η) (Figure 14-5). The elliptic equations are:

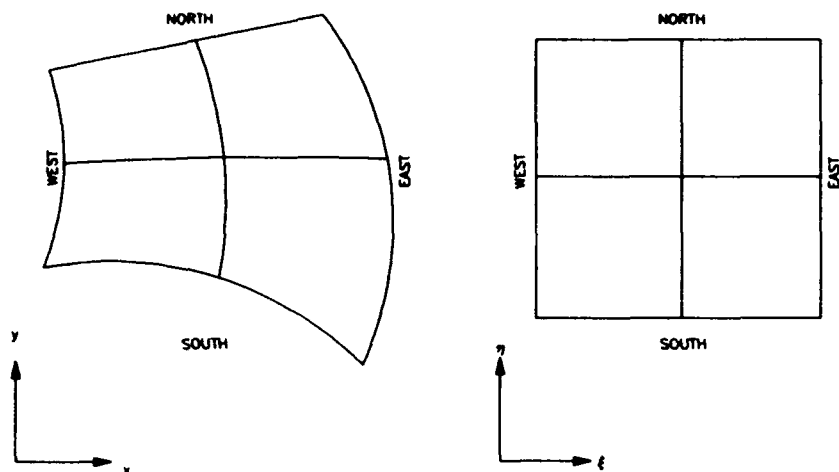

Figure 14-5. Physical and transformed planes

$$\xi_{xx} + \xi_{yy} = P \quad (14-17)$$

$$\eta_{xx} + \eta_{yy} = Q \quad (14-18)$$

with the following boundary conditions:

$$\left. \begin{array}{l} \xi = \xi(x, y) \\ \eta = \text{constant} \end{array} \right\} \text{ on north and south boundaries}$$

$$\left. \begin{array}{l} \xi = \text{constant} \\ \eta = \eta(x, y) \end{array} \right\} \text{ on east and west boundaries}$$

where the functions P and Q may be chosen to obtain the desired grid resolution and alignment.

25. When using a nonorthogonal curvilinear grid, the governing equations must be transformed into curvilinear coordinates. A straightforward method is to transform only the independent variables (x, y) and then solve for the Cartesian components of the velocity and water surface displacement (Johnson 1982). The advantage of this method is its simplicity in generating the transformed equations via the chain rule; although the resulting equations are quite complex. Disadvantages are: (a) the boundary conditions are complicated because the Cartesian velocity components are generally not aligned with the grid lines; (b) a staggered grid (i.e., a grid in which values of velocity and water surface elevation are defined at different points) cannot be readily used; and (c) numerical instabilities may develop (Sheng 1986).

26. To avoid these problems, Sheng transformed the dependent (S, U, V) as well as the independent variables (x, y). Vector quantities (e.g., U, V) are transformed by multiplying the vector by a scale factor. Scalar quantities (e.g., S) in the physical plane are the same in the transformed plane; however, the spatial derivatives require transformation via scale factors. Equations in the transformed plane (ξ, η) can be obtained in terms of the contravariant, covariant, or physical velocity components via coordinate transformations (Thompson, Warsi, and Mastin 1985). Sheng recommended use of contravariant components. Contravariant components ($\underline{a}^1, \underline{a}^2, \underline{a}^3$) are normal to coordinate planes, and covariant components ($\underline{a}_1, \underline{a}_2, \underline{a}_3$) are tangential to coordinate lines (Figure 14-6). The three components are identical in a uniform Cartesian coordinate system with square grid cells, but differ for other systems. Model WICM employs contravariant components in the transformation of the governing equations.

27. The flow rate components in physical space (i.e., $U(i)$ and $V(j)$) are related to the contravariant components (i.e., U^i, V^i, U^j, V^j) by the following equations:

$$U(i) = \frac{g_{11}}{|g|} U^i + \frac{g_{12}}{|g|} V^i \quad (14-19)$$

$$V(j) = \frac{g_{21}}{|g|} U^j + \frac{g_{22}}{|g|} V^j \quad (14-20)$$

where:

$$g_{ij} = \begin{bmatrix} x_\xi^2 + y_\xi^2 & x_\xi x_\eta + y_\xi y_\eta \\ x_\eta x_\xi + y_\eta y_\xi & x_\eta^2 + y_\eta^2 \end{bmatrix} \quad (14-21)$$

or

$$g_{ij} = \begin{bmatrix} g_{11} & g_{12} \\ g_{21} & g_{22} \end{bmatrix} \quad (14-22)$$

and $|g|$ is the determinant of the metric tensor g_{ij} :

$$|g| = g_{11}g_{22} - g_{12}g_{21} \quad (14-23)$$

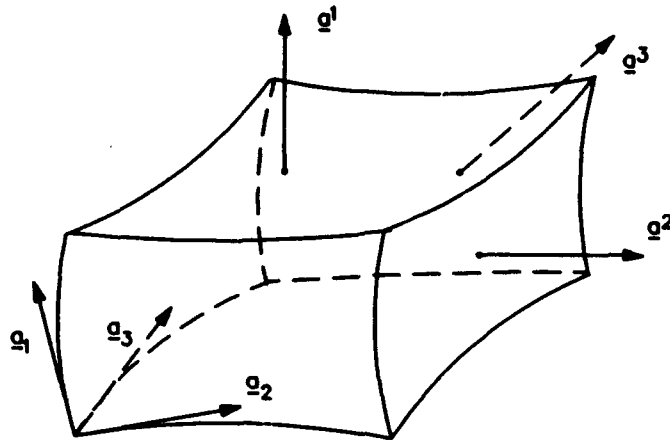

Figure 14-6. Covariant and contravariant components

The surface slope terms are transformed as follows:

$$\frac{\partial S}{\partial x} = g^{11} \frac{\partial S}{\partial \xi} + g^{12} \frac{\partial S}{\partial \eta} \quad (14-24)$$

$$\frac{\partial S}{\partial y} = g^{21} \frac{\partial S}{\partial \xi} + g^{22} \frac{\partial S}{\partial \eta} \quad (14-25)$$

where g^{ij} are inverse metric tensor components:

$$g^{ij} = \frac{1}{|g|} \begin{bmatrix} x_{\eta}^2 + y_{\eta}^2 & -(x_{\eta}x_{\xi} + y_{\eta}y_{\xi}) \\ -(x_{\xi}x_{\eta} + y_{\xi}y_{\eta}) & x_{\xi}^2 + y_{\xi}^2 \end{bmatrix} = \frac{1}{|g|} \begin{bmatrix} g_{22} & -g_{21} \\ -g_{12} & g_{11} \end{bmatrix} \quad (14-26)$$

or

$$g^{ij} = \begin{bmatrix} g^{11} & g^{12} \\ g^{21} & g^{22} \end{bmatrix} \quad (14-27)$$

For details of these transformations, the reader is referred to Thompson, Warsi, and Mastin (1985).

Governing Equations in General Curvilinear Coordinates

28. The transformed governing equations developed by Sheng (1986) are as follows:

ξ -Momentum

$$\begin{aligned} \frac{\partial U}{\partial t} + Inertia^* + gH \left(g^{11} \frac{\partial S}{\partial \xi} + g^{12} \frac{\partial S}{\partial \eta} \right) - \frac{g_{12}}{|g_u|} fU - \frac{g_{22}}{|g_u|} f\bar{V} - \frac{\tau_{\xi\xi}}{\rho} \quad (14-28) \\ - \frac{\tau_{\xi\eta}}{\rho} + \frac{2C_f H_s}{H T \sinh(kH)} \left(\frac{g_{11}}{|g_u|} U + \frac{g_{12}}{|g_u|} \bar{V} \right) + Diffusion^* = 0 \end{aligned}$$

η -Momentum

$$\begin{aligned} \frac{\partial V}{\partial t} + Inertia^* + gH \left(g^{21} \frac{\partial S}{\partial \xi} + g^{22} \frac{\partial S}{\partial \eta} \right) + \frac{g_{12}}{|g_v|} f\bar{U} + \frac{g_{22}}{|g_v|} fV - \frac{\tau_{\eta\eta}}{\rho} \quad (14-29) \\ - \frac{\tau_{\eta\xi}}{\rho} + \frac{2C_f H_s}{H T \sinh(kH)} \left(\frac{g_{12}}{|g_v|} \bar{U} + \frac{g_{22}}{|g_v|} V \right) + Diffusion^* = 0 \end{aligned}$$

Continuity

$$\frac{\partial S}{\partial t} + \frac{1}{|g_s|} \frac{\partial}{\partial \xi} (|g_u| U) + \frac{1}{|g_s|} \frac{\partial}{\partial \eta} (|g_v| V) = 0 \quad (14-30)$$

where

- U, V - contravariant unit flow rate components in the transformed plane (superscripts have been dropped for convenience)
- g^{ij} - inverse metric tensor components (where i and j are 1 or 2)
- g_{ij} - metric tensor components (where i and j are 1 or 2)
- $|g_u|$ - determinant of the metric tensor, $|g|$, at a U-face^m
- \bar{V} - average y-direction unit flow rate at a U-face^m
- $\tau_{\xi\xi}, \tau_{\xi\eta}$ - external surface shear stresses, such as wind stress, in the ξ - and η -directions, respectively
- $\tau_{\eta\xi}, \tau_{\eta\eta}$ - wave stress (gradients in radiation stress), in the ξ - and η -directions, respectively
- $|g_v|$ - determinant of the metric tensor, $|g|$, at a V-face^m
- \bar{U} - average x-direction unit flow rate at a V-face^m
- $|g_s|$ - determinant of the metric tensor, $|g|$, at an S-point^m

* Inertia and diffusion terms are given in Appendix 14-A.

^m S-, U-, V-positions are defined in Figure 14-7.

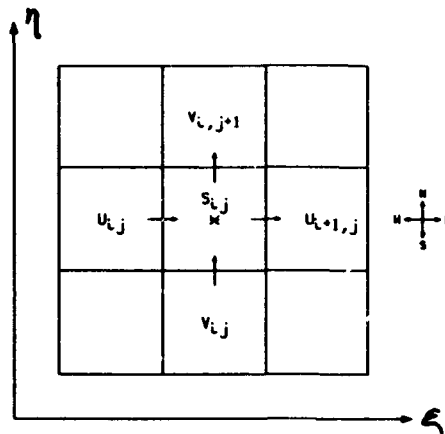

Figure 14-7. Definition of variable positions

Finite Difference Methods

29. Although analytic solutions of the governing equations exist for simple situations, they do not exist for situations generally encountered in the field. Therefore, it is necessary to use numerical approximations of the governing equations to produce a general-purpose model. This can be accomplished by representing the derivatives presented in Equations 14-28 through 14-30 with finite difference approximations.

30. In the finite difference approach, the continuous problem domain is discretized so that dependent variables are defined only at discrete points. Derivatives are approximated by differences resulting in an algebraic problem. Several factors determine whether the solution obtained is a good approximation to the exact solution of the original partial differential equation (PDE) including: truncation error, numerical stability, roundoff error, and discretization error. These factors will be discussed later in this section.

31. As was previously mentioned, the continuous problem domain is represented with a finite difference grid in the (x,y) or (ξ,η) plane (Figure 14-8). It should be noted that the (x,y) and (ξ,η) planes can be used interchangeably here. The (x,y) plane is used merely for explanation purposes. If a variable $a(x,y)$ is defined at each point on the grid as $a(i\Delta x, j\Delta y)$, then a difference equation can be written in terms of the general point (i,j) and its neighboring points:

$$\begin{array}{lll}
 a_{ij} = a(x,y) & a_{i+1,j} = a(x+\Delta x,y) & a_{i,j+1} = a(x,y+\Delta y) \\
 & a_{i-1,j} = a(x-\Delta x,y) & a_{i,j-1} = a(x,y-\Delta y)
 \end{array}$$

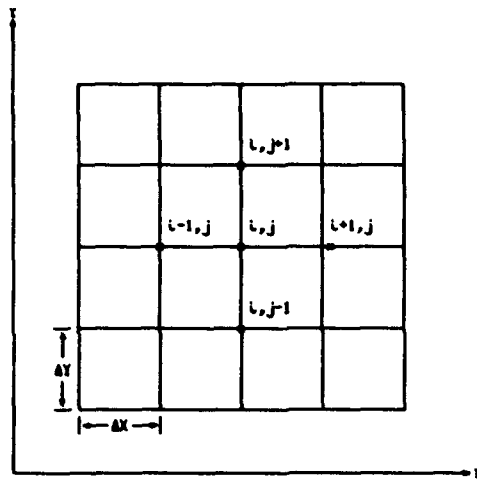

Figure 14-8. Finite difference grid

32. Recall that the definition of the derivative of a function $a(x, y)$ at a point $(x = x_0, y = y_0)$ is given by:

$$\left. \frac{\partial a}{\partial x} \right|_{x_0, y_0} = \lim_{\Delta x \rightarrow 0} \frac{a(x_0 + \Delta x, y_0) - a(x_0, y_0)}{\Delta x} \quad (14-31)$$

This approximation improves as Δx decreases. Developing a Taylor series expansion for $a(x + \Delta x, y)$ about (x_0, y_0) yields:

$$a(x_0 + \Delta x, y_0) = a(x_0, y_0) + \left. \frac{\partial a}{\partial x} \right|_{x_0, y_0} \Delta x + \left. \frac{\partial^2 a}{\partial x^2} \right|_{x_0, y_0} \frac{(\Delta x)^2}{2!} + H.O.T. \quad (14-32)$$

where H.O.T. signifies Higher Order Terms.

A forward difference is formed by rearranging Equation 14-32:

$$\left. \frac{\partial a}{\partial x} \right|_{x_0, y_0} = \frac{a(x_0 + \Delta x, y_0) - a(x_0, y_0)}{\Delta x} - \left. \frac{\partial^2 a}{\partial x^2} \right|_{x_0, y_0} \frac{(\Delta x)}{2!} + H.O.T. \quad (14-33)$$

or by simply using the (i, j) notation, the following is obtained:

$$\left. \frac{\partial a}{\partial x} \right|_{i, j} = \frac{a_{i+1, j} - a_{i, j}}{\Delta x} + O(\Delta x) \quad (14-34)$$

where $O(\Delta x)$ is used to indicate terms of order Δx . The backwards difference can be obtained similarly as:

$$\left. \frac{\partial a}{\partial x} \right|_{i, j} = \frac{a_{i, j} - a_{i-1, j}}{\Delta x} + O(\Delta x) \quad (14-35)$$

The central difference representation is as follows:

$$\left. \frac{\partial a}{\partial x} \right|_{i,j} = \frac{a_{i+1,j} - a_{i-1,j}}{2\Delta x} + O(\Delta x)^2 \quad (14-36)$$

These are only a few examples of the ways in which derivatives can be approximated. Primarily central differences are used to approximate spatial derivatives in the formulation of WICM.

33. The accuracy of these approximations is dependent on a number of factors. Roundoff error is inherent to repetitive computations that are rounded to a finite number of digits, such as the continual solution of the finite difference equations in WICM. Truncation error is defined as the difference between the PDE and the difference approximation. A finite difference representation is said to be consistent if the truncation error vanishes as the grid is refined. A more difficult problem is ensuring that the solution scheme is stable. A stable scheme does not permit errors, such as truncation or roundoff, to grow as the calculations proceed from one time-step to another. Discretization error is the error in the solution to the PDE caused by replacing the continuous problem by a discrete one, and it is defined as the difference between the exact solution of the PDE and the exact solution to the finite difference equation. In other words, it is the sum of the truncation error and any errors introduced by the treatment of the boundary conditions.

34. The finite difference approximations incorporated into WICM are based on a Eulerian system where the velocities and water surface fluctuations are computed at discrete locations within the flow field. A network of grid cells is used to define the parameter locations. A representative grid cell in computational space (ξ, η) is shown in Figure 14-7. In this staggered grid, the water surface fluctuation is defined at the cell center (i, j) , ξ -direction unit flow rates (U) are defined at the "west" (i, j) and "east" $(i+1, j)$ cell faces, and the η -direction unit flow rates (V) are computed at the "south" (i, j) and "north" $(i, j+1)$ cell faces. Finite difference approximations of the governing equations follow. Note that the continuity equation is split into two parts (Equations 14-39 and 14-40) to be used in the solution scheme described in paragraph 35. The sum of these equations is the one original continuity equation.

ξ -Momentum

$$\frac{U_{i,j}^* - U_{i,j}^n}{\Delta t} + I_{i,j}^n + \theta g H g^{11} \left(\frac{S_{i,j}^* - S_{i-1,j}^*}{\Delta \xi} \right) + \quad (14-37)$$

$$(1-\theta) g H g^{11} \left(\frac{S_{i,j}^n - S_{i-1,j}^n}{\Delta \xi} \right) + g H g^{12} \left(\frac{S_{i-1/2,j+1/2}^n - S_{i-1/2,j-1/2}^n}{\Delta \eta} \right) -$$

$$\frac{g_{12}}{|g_u|} f U_{i,j}^n - \frac{g_{22}}{|g_u|} f \bar{V} - \frac{\tau_{\omega}}{\rho} - \frac{\tau_{\omega}}{\rho} + \theta (FRIC) U_{i,j}^* + (1-\theta) (FRIC) U_{i,j}^n + D_{i,j}^n = 0$$

where

- n - previous time level
- * - intermediate time level
- n+1 - solve for this time level
- θ - weighting factor between successive time levels
- I - inertia
- D - diffusion

and

$$FRIC = \frac{2 C_f H_a}{H T \sinh(kH)} \left(\frac{g_{11}}{|g_u|} + \frac{g_{12}}{|g_u|} \frac{\bar{V}}{U_{i,j}} \right)$$

evaluated at time level n

Finite difference forms of the inertia and diffusion terms are given in Appendix 14-A.

η -Momentum

$$\frac{V_{i,j}^{n+1} - V_{i,j}^n}{\Delta t} + I_{i,j}^n + g H g^{21} \left(\frac{S_{i+1/2,j-1/2}^n - S_{i-1/2,j-1/2}^n}{\Delta \xi} \right) + \quad (14-38)$$

$$\theta g H g^{22} \left(\frac{S_{i,j}^{n+1} - S_{i,j-1}^{n+1}}{\Delta \eta} \right) + (1-\theta) g H g^{22} \left(\frac{S_{i,j}^n - S_{i,j-1}^n}{\Delta \eta} \right) + \frac{g_{11}}{|g_v|} f \bar{U} +$$

$$\frac{g_{12}}{|g_v|} f V_{i,j}^n - \frac{\tau_{\omega}}{\rho} - \frac{\tau_{\omega}}{\rho} + \theta (FRIC) V_{i,j}^{n+1} + (1-\theta) (FRIC) V_{i,j}^n + D_{i,j}^n = 0$$

ξ -Continuity

$$\frac{S_{i,j}^* - S_{i,j}^n}{\Delta t} + \theta \frac{|g_u|}{|g_s|} \left(\frac{U_{i+1,j}^* - U_{i,j}^*}{\Delta \xi} \right) + (1-\theta) \frac{|g_u|}{|g_s|} \left(\frac{U_{i+1,j}^n - U_{i,j}^n}{\Delta \xi} \right) + \quad (14-39)$$

$$\frac{|g_v|}{|g_s|} \left(\frac{V_{i,j+1}^n - V_{i,j}^n}{\Delta \eta} \right) = 0$$

η -Continuity

$$\frac{S_{i,j}^{n+1} - S_{i,j}^*}{\Delta t} + \theta \frac{|g_v|}{|g_s|} \left(\frac{V_{i,j+1}^{n+1} - V_{i,j}^{n+1}}{\Delta \eta} \right) + (1-\theta) \frac{|g_v|}{|g_s|} \left(\frac{V_{i,j+1}^n - V_{i,j}^n}{\Delta \eta} \right) - \quad (14-40)$$

$$\frac{|g_v|}{|g_s|} \left(\frac{V_{i,j+1}^n - V_{i,j}^n}{\Delta \eta} \right) = 0$$

Rearranging the terms in Equations 14-37 through 14-40 yields:

ξ -Momentum

$$\theta \left(-gHg^{11} \frac{\Delta t}{\Delta \xi} \right) S_{i-1,j}^* + (1 + \theta (FRIC) \Delta t) U_{i,j}^* + \theta \left(gHg^{11} \frac{\Delta t}{\Delta \xi} \right) S_{i,j}^* = B_4 \quad (14-41)$$

B_1 B_2 B_3
where: B_4 represents all known quantities

η -Momentum

$$\theta \left(-gHg^{22} \frac{\Delta t}{\Delta \eta} \right) S_{i,j-1}^{n+1} + (1 + \theta (FRIC) \Delta t) V_{i,j}^{n+1} + \theta \left(gHg^{22} \frac{\Delta t}{\Delta \eta} \right) S_{i,j}^{n+1} = B_4 \quad (14-42)$$

B_1 B_2 B_3

ξ -Continuity

$$\theta \left(\frac{-|g_u|}{|g_s|} \frac{\Delta t}{\Delta \xi} \right) U_{i,j}^* + [1] S_{i,j}^* + \theta \left(\frac{|g_u|}{|g_s|} \frac{\Delta t}{\Delta \xi} \right) U_{i+1,j}^* = A_4 \quad (14-43)$$

A_1 A_2 A_3

where: A_4 represents all known quantities

η -Continuity

$$\theta \left(\frac{-|g_v|}{|g_s|} \frac{\Delta t}{\Delta \eta} \right) V_{i,j}^{n+1} + [1] S_{i,j}^{n+1} + \theta \left(\frac{|g_v|}{|g_s|} \frac{\Delta t}{\Delta \eta} \right) V_{i,j+1}^{n+1} = A_4 \quad (14-44)$$

A_1 A_2 A_3

Computational Theory

35. The computational procedure used in WICM is based on an Alternating Direction Implicit (ADI) scheme (Roache 1976). Using this method, the ξ - and η -momentum equations are solved separately, and each calculation in time is made in two stages (Figure 14-9). In the first stage, the ξ -continuity and ξ -momentum equations are solved along each row of the grid to progress from time level n to an intermediate time level $*$. The ξ -direction unit flow rate components and water surface fluctuations are solved implicitly, and the η -direction unit flow rate components are supplied from time level n . The ξ -direction unit flow rates from this step represent those at time level $n+1$, whereas the water surface fluctuations are only an approximation to those at time level $n+1$. The η -direction unit flow rate components remain at time level n . In the second stage, the η -continuity and η -momentum equations are solved along each column for the η -direction unit flow rates and the water surface fluctuations at time level $n+1$. ξ -direction unit flow rate components are supplied from the first stage calculations.

36. As shown in the finite difference approximations to the governing equations, a weighting factor θ is used to place the water surface slope and bottom friction terms between time levels n and $n+1$. When the weighting factor equals 0.0, these terms are evaluated at the previous time level n (explicit treatment), whereas when the weighting factor equals 1.0, they are evaluated at the new time level $n+1$ (implicit treatment). Usually a value between 0.0 and 1.0 is used. Tests have shown that a value of 0.55 produces a stable solution with less damping of the solution than occurs with a value of 1.0.

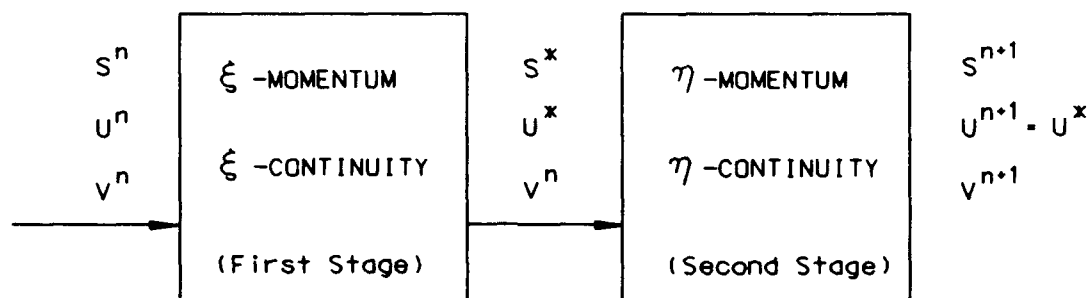

Figure 14-9. Computational procedure for ADI scheme

Tridiagonal matrix

37. As was mentioned earlier, the ξ -direction continuity and momentum and the η -direction continuity and momentum equations are solved separately. For a given segment (Figure 14-10), the ξ -continuity and ξ -momentum equations are alternately solved at S- and U-points, respectively. Similarly, the η -continuity and η -momentum equations are alternately solved at S- and V-points. The equations corresponding to Figure 14-10 are:

$$\begin{array}{rcl}
 C: & A_{11}U_{ij} + A_{21} S_{ij} + A_{31} U_{i+1,j} & - A_{41} \\
 M: & B_{1,i+1}S_{ij} + B_{2,i+1}U_{i+1,j} + B_{3,i+1}S_{i+1,j} & - B_{4,i+1} \\
 C: & A_{1,i+1}U_{i+1,j} + A_{2,i+1}S_{i+1,j} + A_{3,i+1}U_{i+2,j} & - A_{4,i+1} \\
 M: & B_{1,i+2}S_{i+1,j} + B_{2,i+2}U_{i+2,j} + B_{3,i+2}S_{i+2,j} & - B_{4,i+2} \\
 C: & A_{1,i+2}U_{i+2,j} + A_{2,i+2}S_{i+2,j} + A_{3,i+2}U_{i+3,j} & - A_{4,i+2}
 \end{array}$$

where C: indicates the x-continuity equation and M: indicates the x-momentum equation, or in matrix form:

$$\begin{bmatrix} A_{2,i} & A_{3,i} & 0 & 0 & 0 \\ B_{1,i+1} & B_{2,i+1} & B_{3,i+1} & 0 & 0 \\ 0 & A_{1,i+1} & A_{2,i+1} & A_{3,i+1} & 0 \\ 0 & 0 & B_{1,i+2} & B_{2,i+2} & B_{3,i+2} \\ 0 & 0 & 0 & A_{1,i+2} & A_{2,i+2} \end{bmatrix} \begin{bmatrix} S_{i,j} \\ U_{i+1,j} \\ S_{i+1,j} \\ U_{i+2,j} \\ S_{i+2,j} \end{bmatrix} = \begin{bmatrix} A_{4,i} & -A_{1,i}U_{i,j} \\ B_{4,i+1} \\ A_{4,i+1} \\ B_{4,i+2} \\ A_{4,i+2} & -A_{3,i+2}U_{i+3,j} \end{bmatrix}$$

This system of equations is in the form of a banded or tridiagonal matrix and is solved using the Thomas (1949) algorithm (Gaussian elimination and back substitution procedures).

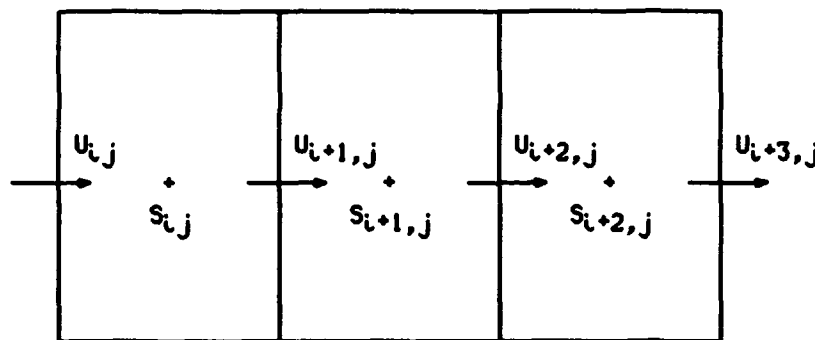

Figure 14-10. ξ -sweep solution segment

38. In the Gaussian elimination step, all lower diagonal elements (A_i 's and B_i 's) are eliminated and are incorporated into other matrix elements. The system of equations is thus reduced to an upper diagonal matrix with only two unknowns per equation. The back substitution sweep then involves the solution of the system of equations for all variables, U_i and S_i .

Boundary Conditions

39. The matrix equation previously shown contains $N-2$ simultaneous equations containing N unknowns. Boundary conditions provide the remaining information needed to solve the system of equations. The boundary conditions are classified into three general categories: open boundaries, land-water boundaries, and subgrid barriers.

Open boundary

40. Boundaries classified as open include: a seaward edge of a computational grid defined as water, or a channel (river) that flows across any boundary. Water surface (tide) levels or unit flow (river flow) rates can be specified along an open boundary as functions of time. An open boundary can also be specified with a uniform flux (zero gradient) boundary condition. Research has been conducted to add a radiation boundary condition option, which relates water levels and flow rates, into the model. This option will be incorporated in a later release of WICM.

Tidal boundary

41. A tidal boundary condition (TBC) allows for fluctuations in the free surface and is, therefore, applied at an S -point (Figure 14-11). The computations proceed from the first internal U -face to the last S -point. For the case of a tidal boundary on the west (or south), a special formulation of the momentum equation at the next internal U -face is required:

$$B_{2,i+1}U_{i+1,j} + B_{3,i+1}S_{i+1,j} = B_{4,i+1} - B_{1,i+1}S_{i,j} \quad (14-45)$$

The sweep proceeds from this U -point to the easternmost S -point.

42. For a tidal boundary on the east (or north), a special formulation of the momentum equation at the last internal U -face is required:

$$B_{1,i_{max}}S_{i_{max}-1,j} + B_{2,i_{max}}U_{i_{max},j} = B_{4,i_{max}} - B_{3,i_{max}}S_{i_{max},j} \quad (14-46)$$

The sweep proceeds from the westernmost S -point to this U -point.

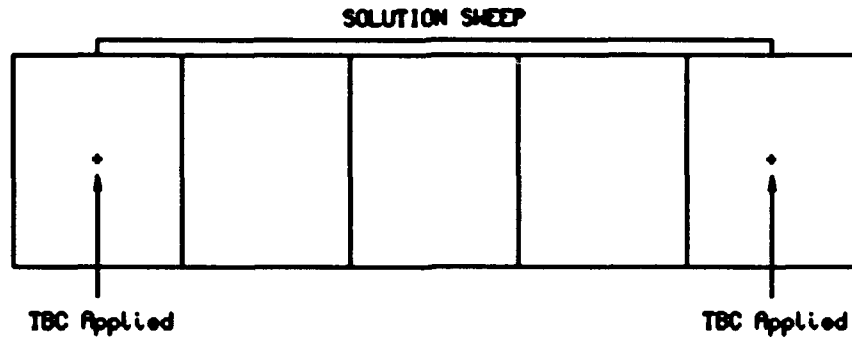

Figure 14-11. Tidal boundary condition (TBC)

River boundary

43. A river boundary condition (RBC) allows flow into or out of a computational grid. Being a flow condition, the river boundary condition is applied at a U - or V -face (Figure 14-12). The solution proceeds from the next internal S -point to the last S -point. For a river boundary on a west (or south) boundary a special formulation of the A_i in the continuity equation at the first S -point is required:

$$A_{21}S_{1,j} + A_{31}U_{1+1,j} = A_{41} - A_{11}U_1 \quad (14-47)$$

The sweep proceeds from this S -point to the last S -point.

44. For a river boundary on an east (or north) boundary, a special formulation of the A_i in the continuity equation at the last S -point is required:

$$A_{1,imax}U_{imax,j} + A_{2,imax}S_{imax,j} = A_{4,imax} - A_{3,imax}U_{imax+1,j} \quad (14-48)$$

The sweep proceeds from the first S -point to this last S -point.

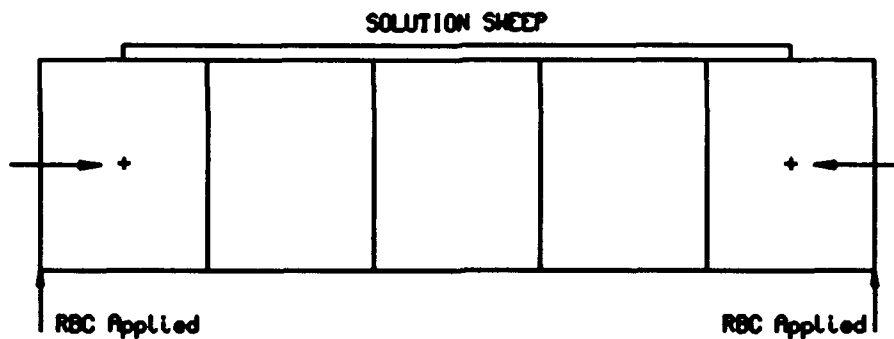

Figure 14-12. River boundary condition (RBC)

Uniform flux boundary condition

45. A uniform flux (or zero gradient) boundary condition (UFBC) implies that flow is constant across such a boundary. Similar to a river boundary, the UFBC is applied at a *U*- or *V*-face, and the solution begins at the next internal *S*-point (Figure 14-13). For a UFBC on a west (or south) boundary, a special formulation of the A_i in the continuity equation at the first *S*-point is required:

$$A_{2i}S_{i,j} + (A_{1i} + A_{3i})U_{i+1,j} = A_{4i} \quad (14-49)$$

The sweep proceeds from this *S*-point to the last *S*-point.

46. For a UFBC on an east (or north) boundary, a formulation of the A_i in the continuity equation at the last *S*-point is required:

$$(A_{1,i_{max}} + A_{3,i_{max}})U_{i_{max},j} + A_{2,i_{max}}S_{i_{max},j} = A_{4,i_{max}} \quad (14-50)$$

The sweep proceeds from the first *S*-point to this last *S*-point.

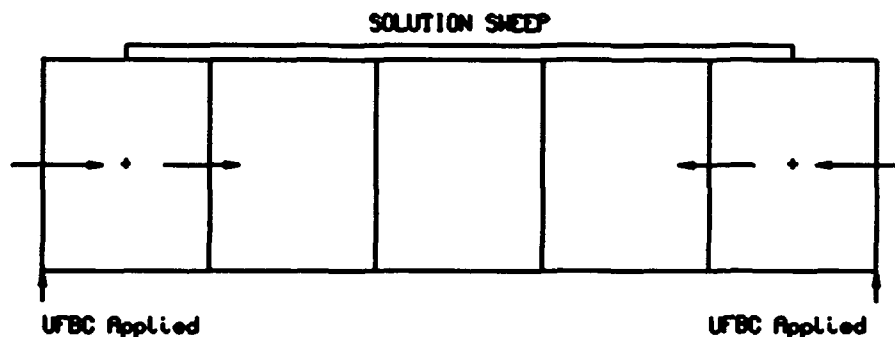

Figure 14-13. Uniform flux boundary condition (UFBC)

Land-water boundaries

47. With land-water boundaries (i.e., the coastline), water velocities normal to the land-water interfaces are set equal to zero in the WICM model. This condition means that the boundary is closed and no flow is permitted across such a boundary. Therefore, this model lacks the capability to simulate flooding and drying of low-lying areas. This capability will be added with a future release of WICM.

48. A land-water (closed) boundary is applied at a *U*- or *V*-face, and the solution begins at the next internal *S*-point. For a land-water boundary

on a west (or south) boundary, a special formulation of the A_i in the continuity equation at the first S-point is required:

$$A_{2i}S_{i,j} + A_{3i}U_{i+1,j} = A_{4i} \quad (14-51)$$

The sweep proceeds from this S-point to the last S-point.

49. For a land-water boundary on an east (or north) boundary, a special formulation of the A_i in the continuity equation at the last S-point is required:

$$A_{1,i_{max}}U_{i_{max},j} + A_{2,i_{max}}S_{i_{max},j} = A_{4,i_{max}} \quad (14-52)$$

The sweep proceeds from the first S-point to this last S-point.

Subgrid barriers

50. Subgrid barriers (e.g., breakwaters) are treated as thin, impermeable walls that extend above the water surface, preventing flow from one cell to the next. These exposed barriers are defined along specified interior cell faces and can be used to represent any nonovertopping structure in a study area. They can also be used to represent small islands when using a coarse grid. A subsequent release of WICM will include submerged and overtopping barriers.

PART III: DEFINITION OF INPUT DATA FORMAT

51. The input data set format was designed to resemble the format required by the series of models released by the USAE Hydrologic Engineering Center. It is the intent that this structure, being familiar to Corps personnel, will reduce the time needed to learn this system. The general format of the input data set records, where a record refers to one line of data, is presented below:

- a. Each record is divided into 10 fields containing 8 columns each.
- b. Field 1 (i.e., columns 1 through 8) contains a mnemonic identification label that describes the purpose or function of each record.
- c. Fields 2 through 10 contain data that may be real, integer, or character in type. Integers must be right-justified. Real numbers must also be right-justified if the decimal point is omitted. Character data do not need to be right- or left-justified.
- d. Array data, such as depths, are read with DO or Implied DO loops. No label is required for array data records. However, a general specification record, such as BATHSPEC, which defines bathymetric attributes, must precede that array.

52. Spelling of record identification labels and alphanumeric variables is important. Misspelled entries will result in either recognized error conditions that force the model to abort execution or bypassing of desired user-defined operations, such as saving time-history data.

53. Certain records and variables have been assigned default values in the model for minimizing input data and computer resources. Thus, not all input data records will be needed for each application, and only those records pertinent to the simulation or required by the model should be included. Default values are representative of those chosen in previous studies performed by the U.S. Army Engineer Waterways Experiment Station Coastal Engineering Research Center. Although these quantities may not be applicable to all studies, they can serve as a guide when selecting alternative values.

54. Default values are processed when the record field corresponding to that variable is blank. Hence, the user must be careful when leaving fields blank in a record; blank fields will not necessarily result in an input variable being assigned a value of zero. Input variables and their respective default values are noted in Appendix 14-B. The following discussion pertains to the general format of the input records given in Appendix 14-B.

55. Each record is presented in a standardized tabular format and has as its heading the mnemonic identification label or name with a brief description of its function. Following its name, the record has an abbreviated note documenting whether it is required for a simulation. These abbreviations have the following definitions:

(Req) Record or variable is required for each simulation.

(Opt) Record or variable is optional. Omitting this item results in either the default value being used or the defined operation not being performed.

(C-opt) Record or variable is required if related or parent options have been selected.

For example, record TIMESPEC, presented in Appendix 14-B, contains the note (Req), meaning that this record must reside in the input data set for each simulation. Record CHNGBATH contains the note (Opt), meaning this record is optional and is used only when changes to the bathymetric data are desired. Record XSTRETCH contains the note (C-opt), meaning this record is required only if a stretched Cartesian grid has been specified on the GRIDSPEC record.

56. Input variables, presented in column 2 of each table, are referenced to their respective record fields shown in column 1. Generally, data for each variable occupy a single 8-column data field. However, variables assigned titling or formatting information can occupy several fields.

57. Variable attributes are presented in columns 3 through 6 of each table. Valid data types are listed in column 3 and can be real, integer, or alphanumeric. Abbreviations presented in this column are described below:

Char*16 Alphanumeric character string containing up
 to 16 characters

Char*8 Alphanumeric character string containing up
 to 8 characters

Integer Integer data

Real Real (floating point) data

58. Column 4 of each table defines whether the respective variable must be assigned a value. Abbreviations listed in this column have identical meanings as those for the records. Default values are listed in column 5. A blank entry in this column denotes that the respective variable does not have a default value.

59. Column 6 of each table lists the variables' permitted data type or all valid character strings. Variables having integer or real data types are specified with the following notation:

A Alphanumeric values

+R Positive real values

R Positive, zero, or negative real values

+I Positive integer values

I Positive, zero, or negative integer values

60. Variable definitions are listed in column 7 of each table. Variables whose quantities are unit-dependent contain a reference to that variable designating its system of units. For example, variable TMAX is assigned a value having units defined by variable TUNITS. Variables defining input data units and the record on which they reside are presented below.

<u>Variable</u>	<u>Record</u>	<u>Definition</u>
BUNITS	BATHSPEC	Bathymetry/topography data
FUNITS	FUNCTION	Tidal and discharge boundary data
GUNITS	GRIDSPEC	Numerical grid data
SUNITS	GENSPECS	Model computations and output
TUNITS	TIMESPEC	Time-dependent variables
WUNITS	WINDSPEC	Wind velocity data

PART IV: DISCUSSION OF INPUT DATA REQUIREMENTS

61. The types of data processed by WICM are extensive and encompass a wide range of possible applications. Since each application is unique, the type of input data required for each specific study will vary. In this discussion of model input, data have been divided into seven categories to present model capabilities and data requirements. These categories are:

- a. Model control specifications.
- b. Grid description.
- c. Physical characteristics.
- d. Boundary conditions.
- e. Wind-field specifications.
- f. Wave field specifications.
- g. Output specifications.

62. Table 14-2 presents WICM input data records pertaining to each category. A record refers to one line of data, and each record begins with a mnemonic character string to identify one record type from another. Record format is defined in Part III. Detailed specification of each record follows. While reading this part of the report, the user will find it beneficial to refer to Appendix 14-B, where descriptions for each input data record are given.

Model Control Specifications

63. Model control parameters define how the user controls the model's execution. Records contained in this category include GENSPECS, TIMESPEC, STARTUP, and ADDTERMS.

64. Record GENSPECS is used to specify the general title of the simulation (TITLE) and the system of units (SUNITS) used for model computations and displaying model results. Variable names are typically given in parentheses. In addition to the general title, other input data records have provisions for titles. Although this information is optional, it can be very helpful when reviewing a series of simulations. A title should specifically

Table 14-2
Input Data Set Records

<u>Category</u>	<u>Record Name</u>
Model control specifications	GENSPECS TIMESPEC STARTUP ADDERMS
Grid description	GRIDSPEC GRIDCORN XSTRETCH YSTRETCH
Physical characteristics	BATHSPEC CHNGBATH FRICTION FRICTABL CHNGFRIC XBARRIER YBARRIER
Boundary conditions	XBOUNDRY YBOUNDRY FUNCTION CNRECORD CONSTIT TERECORD TFRECORD TABELEV TABFLOW
Wind-field specifications	WINDSPEC TABWINDS
Wave field specifications	WAVESPEC
Output specifications	PRWINDOW RECGAGE RECSNAPS XRECRANG YRECRANG

state data set attributes, such as data source or collection date, to differentiate it from data used in other simulations.

65. Model output is presented in either English or metric units. However, the user can specify a different system of units for the input data. For example, the user can supply wind velocity data having units of either miles per hour, feet per second, meters per second, or knots. WICM will perform the necessary conversion to place the input data into the system of units used for computations.

66. Record TIMESPEC controls the processing of all time-related variables. Variable DT defines the time-step or time interval between consecutive flow field computations and has units of seconds. Variable TUNITS controls the units of all other time-dependent variables. Valid units for TUNITS are hours, minutes, and seconds.

67. For meaningful model results, the selected time-step must be consistent with the Courant criterion C_r . The maximum permissible time-step size for a given value of C_r can be computed from:

$$C_r = \frac{\sqrt{gH}}{\Delta x / \Delta t} \quad (14-53)$$

where g is the gravitational acceleration, H is the depth at that cell, Δx is the dimension of the smallest grid cell within the computational domain, and Δt is the length of the time-step. Experience indicates that the value for C_r should be less than 5. Larger values of the Courant number may be permissible at locations distant from the area of interest within the computational domain; however, numerical accuracy will be affected.

68. Variable IT1 defines the time-step number at the start of the simulation, and variable IT2 defines the length of the simulation (in time-steps). Typically, a simulation begins at time-step 1 and has a duration ranging from one to several hours. This duration provides the hydrodynamic model sufficient time in which to develop accurate circulation fields and avoids the generation of numerical instabilities induced by instantaneously applying forces to a static water basin. Longer simulations are required for tidal forcing. Additional details concerning duration are discussed with tidal boundary conditions.

69. Variable NFREQ specifies the frequency at which numerical gauge time-history data (i.e., water velocities and free surface elevations) are

saved for subsequent processing by the post-processing package in the CMS. Numerical gauge locations (locations for which time histories are saved) are selected with the RECGAGE record, which is discussed in the model output specifications section. Variable ITBRKINC defines the time interval for saving field data for use in a follow-up simulation (see STARTUP record).

70. The STARTUP record defines the flow-field conditions at the start of a simulation. Normally, the initial flow field is assumed to be static (i.e., water surface elevations and unit flow rates are set to zero). Although this assumption may not be entirely correct, it is often necessary because prototype data rarely have the resolution to accurately define the flow field throughout the model domain at the start of a simulation. To allow for dampening of transients associated with starting from static initial conditions, the simulation should begin well before the time period of interest.

71. Initial conditions can also be supplied from a previous simulation (SELEV = HOTSTART). These simulations must be sequential in time since the second simulation is a continuation of the first. When initial conditions are supplied from a previous simulation, the second simulation is referred to as a "hotstart." Slight computational inaccuracies also exist for hotstart conditions due to data roundoff incurred by storing formatted data. These precision errors cause transients that are significantly smaller than those generated from starting with static conditions and can be minimized to a greater extent by overlapping the simulations. Overlapping is performed by saving the hotstart data file approximately 10 to 20 time-steps before the end of the first simulation. The second simulation is then run with this hotstart file. When analyzing model results, the user should ignore the repeated (overlapping) time-steps in the second simulation.

72. When a hotstart is selected, variable IT1 on record TIMESPEC must be set to the time-step when the desired field data were saved. These times are printed in the input data summary file of the preceding run. The hotstart simulation will begin at time IT1 and end at time IT2 + IT1. Therefore, the user should not incorporate the simulation time of the previous run into variable IT2. All remaining time variables should reflect the change in starting time. The STARTUP record also contains variable SECHO. A brief or full report of input data is written to the output file by specifying SECHO equal to SHORT or DETAILED, respectively.

73. Record ADDTERMS must reside in the input data set if either the inertial or diffusion terms are to be computed in the Navier-Stokes calculations. Variable ADVFLAG is set to either NO for no inertial terms or YES to include the inertial terms. Diffusion is set with variable DIFFLAG equal to either NO for no diffusion or YES for diffusion. The value of the diffusion coefficient is defined by variable AH and is treated as a constant in WICM. The value of the Coriolis coefficient is defined by variable COR on record ADDTERMS.

Grid Description

74. The study area is defined in the model via a computational grid. The grid is composed of rectilinear or curvilinear cells, where each cell is assigned a two-dimensional index. The first index (i) corresponds to the x-coordinate, and the second index (j) corresponds to the y-coordinate. The grid index system is presented in Figure 14-14. All flow field data, such as depths, are assigned and referenced to their respective grid cells with this system. Guidelines for developing grids are discussed in Appendix A of the 1991 edition of this manual.

75. WICM permits uniform grids; rectilinear stretched grids, where successive grid cells can smoothly vary in width; or general curvilinear grids. Procedures for constructing a grid are presented in documentation of package CMSGRID (Appendix A, 1991 edition of this manual). CMSGRID guidelines for grid generation pertaining to hydrodynamic models are therefore useful for WICM applications.

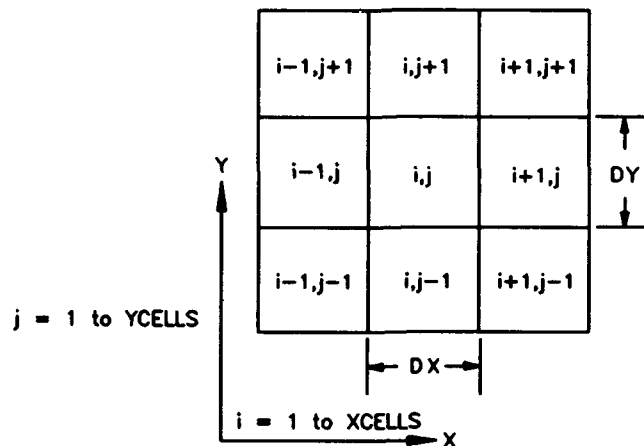

Figure 14-14. Definition of coordinate system and grid cell convention

76. Selection of grid coordinate systems is controlled by variable GRTYPE on record GRIDSPEC. A uniform, or constant, grid cell size is selected by assigning the character string RECTANG to variable GRTYPE, whereas string RSTRETCH selects a stretched rectilinear grid. If the stretched grid option is selected, record GRIDSPEC must be followed by a set of XSTRETCH and YSTRETCH records (Table 14-3). These records are generated by the interactive grid generation program MAPIT contained in package CMSGRID and can be placed directly into the input data set without modification. The reader can refer to Appendix A in the 1991 edition of this manual for more information on XSTRETCH and YSTRETCH.

77. A general curvilinear grid is selected by assigning the character string CURVILIN to variable GRTYPE. If the curvilinear grid option is selected, record GRIDSPEC must be followed by a GRIDCORN record. This record specifies the format of the x- and y-coordinate (XCT and YCT) data produced by the grid generation program EAGLE; the data directly follow the GRIDCORN record. (The CMSGRID package will contain the EAGLE software.)

78. Variable GUNITS on record GRIDSPEC controls the system of units for the computational grid. Valid units are feet and meters. WICM will convert the data to the system of units for computations (SUNITS) internally. Variables ICELLES and JCELLS specify the number of grid cells in the x- and y-directions, respectively. Variables ALXREF and ALYREF on record GRIDSPEC specify a grid's overall length in the x- and y-directions, respectively. The variable XMAP is assigned the value of the map scale if relative map distances were used in generating the grid. For example, a map with a scale of 1:80,000 is used to generate a stretched rectangular grid. If the physical

Table 14-3
Sample XSTRETCH and YSTRETCH Records

XSTRETCH	1	4	-.696333695	.696333695	.933460501
XSTRETCH	4	9	-6.69031772	5.80606023	.277821490
XSTRETCH	9	19	.143110486	.710267924	.770050578
XSTRETCH	19	26	.167892340	.730987967	.809764231
.YSTRETCH	1	17	-.500000000	.500000000	1.00000000
YSTRETCH	17	26	.177832310	.755987967	.823454231

map distances (i.e., distances computed using the appropriate scaling) are used to generate the mapping coefficients, then XMAP is 1.0 because no conversion is necessary. However, if the map distances (i.e., grid distances measured in map inches) are used to generate the mapping coefficients, then XMAP must be 6666.67 to convert map inches to physical distances (e.g., in feet).

Physical Characteristics

79. A study area's physical characteristics include its (a) topography/bathymetry, (b) bottom friction coefficients, and (c) if applicable, any barriers or obstructions influencing tidal circulation or storm surge levels. Records pertaining to each of the above topics are described individually in the following sections.

Topography/bathymetry

80. Each grid cell must be assigned a water depth or land elevation. Topography/bathymetry data are referenced to an arbitrary datum. Typically, the map datum from which the depths are taken is used. Water cells are designated by positive values, whereas land cells are zero or negative values.

81. One BATHSPEC record is required for defining the general characteristics of the topography/bathymetry array and must precede this array. Variable BUNITS defines the units of topography/bathymetry data. Valid units are feet, meters, or fathoms. The input sequence for reading this array is controlled by variable BSEQ. Eight options for the input sequence are available for reading the array data and are documented in Table 14-4. As an example, for the first input sequence (Figure 14-15), the depths are read along the x-direction, then y is incremented to a value of 2, and again the sweep in the x-direction takes place. This procedure is repeated until the entire array is read. The input format for reading this array can be specified by the user with variable BFORM.

82. The maximum water depth is specified with variable DLIMIT, and any array values deeper than DLIMIT are set to DLIMIT (in BUNITS). Grid-wide adjustments to land elevations contained in the topography/bathymetry array can be made with variable LDATUM. The value assigned to this variable is subtracted from all land cells in the grid. Positive LDATUM values will increase land elevations, whereas negative values will decrease land eleva-

Table 14-4
Input Sequence for Array Data

No	Sequence	Description
1	XY	DO 1 J=1,JCELLS 1 READ(LUN,BFORM) (VAR(I,J),I-1,ICELLS)
2	-XY	DO 2 J=1,JCELLS 2 READ(LUN,BFORM) (VAR(I,J),I-ICELLS,1,-1)
3	X-Y	DO 3 J=JCELLS,1,-1 3 READ(LUN,BFORM) (VAR(I,J),I-1,ICELLS)
4	-X-Y	DO 4 J=JCELLS,1,-1 4 READ(LUN,BFORM) (VAR(I,J),I-ICELLS,1,-1)
5	YX	DO 5 I=1,ICELLS 5 READ(LUN,BFORM) (VAR(I,J),J-1,JCELLS)
6	-YX	DO 6 I=1,ICELLS 6 READ(LUN,BFORM) (VAR(I,J),J-JCELLS,1,-1)
7	Y-X	DO 7 I=ICELLS,1,-1 7 READ(LUN,BFORM) (VAR(I,J),J-1,JCELLS)
8	-Y-X	DO 8 I=ICELLS,1,-1 8 READ(LUN,BFORM) (VAR(I,J),J-JCELLS,1,-1)

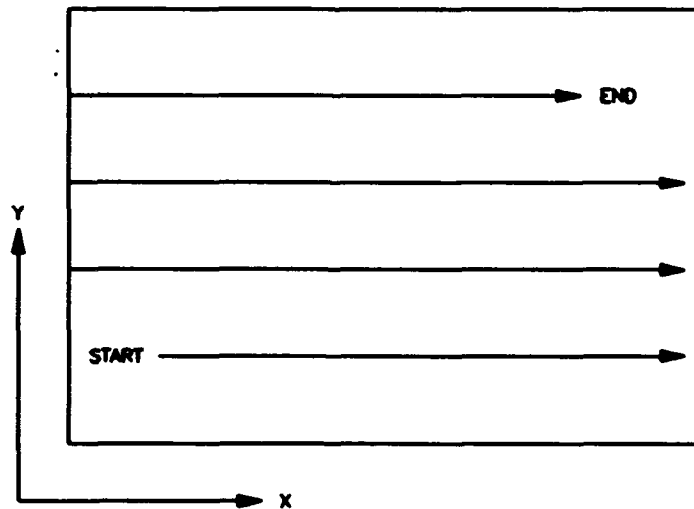

Figure 14-15. Input sequence - option 1

tions. Similarly, grid-wide adjustments to water depths can be made with variable WDATUM. The value assigned to this variable is added to all water cells. Since these cells have positive values, positive WDATUM values produce deeper basins, and negative WDATUM values produce shallower basins.

83. Changes to the topography/bathymetry array can also be made to individual cells, or a group of cells with record CHNGBATH. This record allows the user to quickly change values assigned to the bathymetry array (using variable BATH) without editing the array itself. It should be noted that (a) values of the variable BATH on the CHNGBATH record are assumed to have units consistent with those selected for bathymetry/topography (i.e., variable BUNITS on record BATHSPEC), and (b) LDATUM and WDATUM are not applied to cells specified with record CHNGBATH; therefore, the effect of nonzero LDATUM and WDATUM must be included in the value of variable BATH.

84. Variables X1INDX and X2INDX on the CHNGBATH record specify the minimum and maximum cell numbers in the x-direction, respectively, where the bathymetry/topography value will change. Similarly, variables Y1INDX and Y2INDX on the CHNGBATH record specify the minimum and maximum cell numbers in the y-direction, respectively, where the bathymetry/topography value will change. More than one CHNGBATH record is permitted.

Bottom friction coefficient

85. Several choices are available for specifying bottom friction coefficients. Bottom friction coefficients may be specified as constant C_f values (FRDEF = CONSTANT), as individual values for each cell (FRDEF=TABLE), or as functions of depth/elevation (FRDEF = VARYBATH). For the constant value option, separate friction coefficients can be assigned to land and water cells. Friction coefficients for land are assigned to variable FRLAND, and coefficients for water cells are specified by variable FRWATR. A coefficient is assigned to each cell based on its topography/bathymetry value at the start of a simulation and will remain constant throughout the simulation.

86. The tabular friction option (FRDEF=TABLE) requires friction coefficients for each individual cell. The friction array must follow immediately after the FRICTION record. The input sequence for reading the friction array is controlled by variable FSEQ on record FRICTION. Eight options for the input sequence are available for reading the array data and are documented in Table 14-4. The input format for reading the friction array can be specified by the user with variable FFORM on record FRICTION.

87. The depth-variable friction option requires at least two FRICTABL records, which must follow immediately after the FRICTION record in the input data set. Each FRICTABL record must contain a depth/elevation (FDEPTH) and a corresponding friction value (FRICT) for creating a tabular friction function. Cells with a water depth greater than or equal to FDEPTH are assigned a friction value of FRICT. Cells whose depths are deeper than the deepest depth entered in the table are assigned the friction coefficient corresponding to the deepest table depth.

88. In deep water, bottom friction has a negligible effect on long-wave hydrodynamics. Variable FDMAX on record FRICTION defines the maximum depth at which bottom friction influences hydrodynamics. It is provided for reducing computer memory requirements when the depth-variable option is requested and has a default value of 300.0 ft.

89. Friction coefficients can also be assigned to individual cells, or a group of cells with record CHNGFRIC. Record CHNGFRIC overrides the above options for all cells entered on this record. This feature permits the user to change a cell's friction coefficient in certain areas, such as rivers, where parameters differ from the norm. Variables (X1INDX, Y1INDX) and (X2INDX, Y2INDX) define the "patch" of cells where friction values are to be changed. More than one CHNGFRIC can be used in a simulation. These records must follow FRICTION and, if applicable, FRICTABL records.

Barriers

90. Subgrid barriers refer to flow field obstructions, such as breakwaters, whose widths are much narrower than the widths of adjacent grid cells, but have lengths that are equal to or greater than those of a grid cell. Barriers are treated as exposed, impermeable structures in model WICM.

91. Barriers that prevent or impede flow in the x-direction (i.e., barriers perpendicular to the x-axis) are specified with XBARRIER records (Figure 14-16). A barrier for a particular cell is defined at the cell face, where the velocity is also defined. Barrier grid locations are defined with variables BRPOS1, BRPOS2, and BRPOS3. Variable BRPOS1 is assigned the barrier's grid cell X-index, and variables BRPOS2 and BRPOS3 are assigned the barrier's starting and ending grid cell Y-indices, respectively.

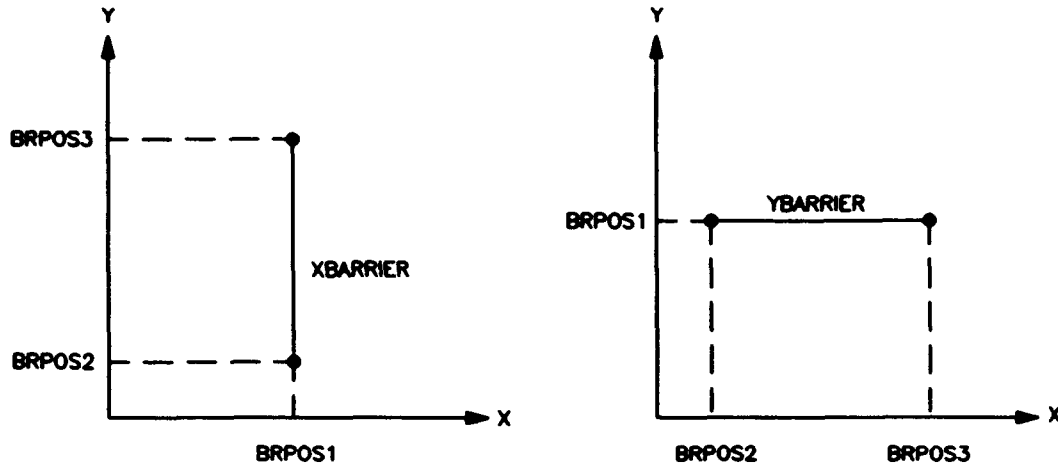

Figure 14-16. Definitions of XBARRIER and YBARRIER

92. Similarly, YBARRIER records define those barriers that prevent or impede flows in the y-direction. Variable BRPOS1 is assigned the barrier's grid cell Y-index. Variables BRPOS2 and BRPOS3 are assigned the barrier's starting and ending grid cell X-indices.

Boundary Conditions

93. WICM is generally applied in regions where three grid boundaries lie in open water (e.g., open coast regions). In these cases, the flow field is typically driven or forced by prescribing a time series of water surface levels along this boundary throughout a simulation. Regions may also contain a river whose flow influences local circulation patterns. These river flow rates can be specified as a function of time.

94. To encompass as many modeling scenarios as possible, three types of open boundary conditions are incorporated into this model, including:

- a. Tidal elevation.
- b. Discharge.
- c. Uniform flux condition.

Discussion of these open boundary conditions is presented in three parts. First, an overview of each type of open boundary describes its application and attributes. Second, input data requirements for defining a boundary's grid location are presented. Third, input data requirements for entering time series data are described.

Overview of open boundary conditions

95. With the tidal elevation boundary condition, the flow field is driven by specifying the water surface elevations as a function of space and time along a grid's outer boundary. Water surface elevations are measured relative to the topography/bathymetry datum and can be supplied from tidal constituent parameters or tabulated data.

96. Two options are available for specifying the spatial distribution of data along a boundary. The first option applies a spatially constant elevation function across a boundary segment where each cell in the segment acts in unison, having identical water surface elevations at each time-step. This option is normally applied along a grid's lateral boundary (i.e., perpendicular to the shoreline) in areas of deep water. It can also be used along a seaward boundary if no significant phase or elevation differences occur along this segment.

97. The second option is a spatially variable elevation forcing boundary where separate time-series functions are specified at each end of a boundary segment. Elevations for each cell within the boundary segment are obtained by linearly interpolating the two forcing functions (at each time-step). This option is typically applied along the grid's seaward boundary. A boundary can be treated as one continuous segment, or as several segments.

98. Discharge boundary conditions can be specified at any interior grid cell face. An error message will be printed and execution terminated if this boundary condition is specified at the edge of the computational grid. Furthermore, depths on each side of the boundary cell faces must be greater than zero, signifying water cells. Discharges are required to have units of flow per unit width (i.e., cubic feet/second/foot or cubic meters/second/meter), and flow trajectories are referenced relative to the grid axes. Positive discharge rates define flows directed in the positive x- or y-directions, whereas negative discharge rates define flows directed in the negative x- or y-direction.

99. A uniform flux boundary condition is similar to a river discharge boundary condition in that a flux is applied at the boundary cell face. However, the flux through the cell face is computed internally by the model, as opposed to a user-defined flux. This boundary condition assumes that the flux through the boundary cell face equals the flux through the opposing cell face.

100. The uniform flux boundary condition is the most common lateral boundary condition for wave-induced current applications. There are three situations where it can be applied. First, it can be applied across the entire lateral boundaries for current fields, in relatively shallow water, driven within the model domain by wave forcing.

101. Second, uniform flux boundary conditions can be applied across the lateral boundaries near the shoreline (Figure 14-17). Tidal signals generated from constituents, which are normally prescribed as a forcing function along the seaward boundary, should not be used in this reach because bottom friction effects attenuate the tidal signal. Hence, forcing a tidal signal in this reach may not accurately depict the physical processes occurring within the study area. Third, the uniform flux boundary condition may be applicable to steady-state, storm surge analyses of lakes. However, wind must be the only driving force causing surge, and resulting seiches cannot be simulated with this boundary condition.

102. Because the uniform flux boundary condition provides an estimate of the actual flow entering/exiting the grid, its use will introduce error into the flow field solution. Bottom friction effects can dampen these inaccuracies, ensuring accuracy of results in the area of interest, if the uniform flux boundaries are placed a suitable distance away from the area of interest. Generally, this distance ranges from 1.5 to 2.0 times that distance measured from the shoreline to the seaward boundary.

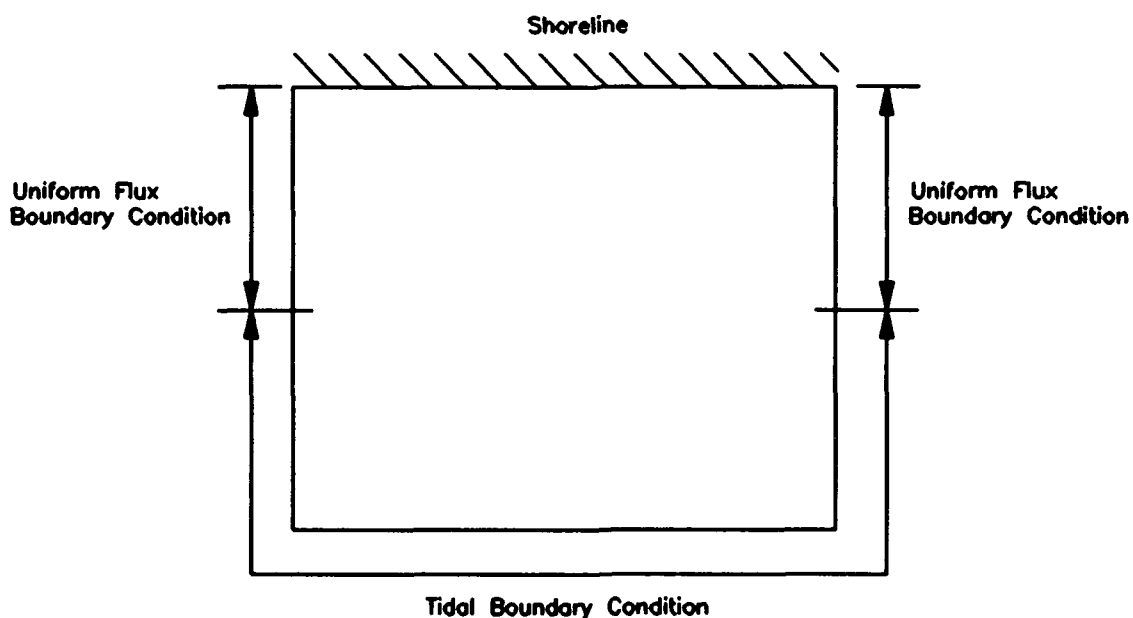

Figure 14-17. Uniform flux boundary condition

Spatial description of open boundaries

103. Each distinct open boundary must be declared by either an XBOUNDRY or a YBOUNDRY record. Record XBOUNDRY defines a boundary that induces or forces flow in the x-direction (i.e., boundary is perpendicular to the x-axis) (Figure 14-18). Conversely, a YBOUNDRY record defines a boundary that is perpendicular to the y-axis.

104. Boundary types are declared on records XBOUNDRY and YBOUNDRY with variable BNDTYP and can be assigned any of the three options previously discussed: (a) spatially constant tide boundaries are selected with character string CONSTELV, (b) spatially variable tide boundaries are chosen with string INTRPELV, (c) spatially constant discharge boundaries are selected with string CONSTDIS, and (d) uniform flux boundaries are selected with string UNIFLUX.

105. This model employs a staggered grid cell system where water surface levels, x-direction velocities, and y-direction velocities are defined at different locations on a cell. These positions were defined in Figure 14-7. Elevations are referenced relative to a cell's center, and river discharge boundaries are specified along cell faces.

106. Boundary grid positions are defined with variables BNPOS1, BNPOS2, and BNPOS3. For XBOUNDRY records, variable BNPOS1 is assigned the boundary's X-index, whereas variables BNPOS2 and BNPOS3 are assigned the Y-indices of the starting and ending cells, respectively (Figure 14-18). For YBOUNDRY records, variable BRPOS1 is assigned the boundary's Y-index, and variables BRPOS2 and BRPOS3 are assigned the X-indices of the starting and ending cells, respectively. Boundaries can be identified by assigning each one a boundary name with variable BNDNAM on the XBOUNDRY or YBOUNDRY records.

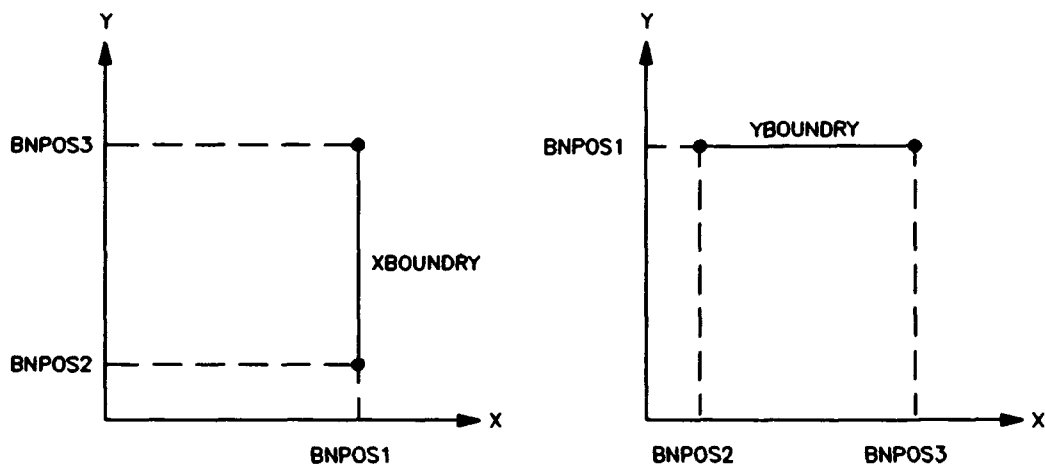

Figure 14-18. Definition of XBOUNDRY and YBOUNDRY

Time-series description of open boundaries

107. Time-series data are required for driving the flow field for all of the boundary options: (a) spatially constant elevation, (b) spatially variable elevation, and (c) spatially constant discharge boundary options. XBOUNDRY and YBOUNDRY variables BDNFN1 (for all three options) and BDNFN2 (for spatially variable elevation boundaries only) define which group of time-series data is to be used to drive the boundary, and correspond to the function index number assigned to variable FUNNO on record FUNCTION. For example, an application may have a spatially variable elevation boundary and two spatially constant elevation boundaries (Figure 14-19). This application would require two FUNCTION records (one at each end of the spatially variable boundary) to define the time series at two locations. These values are also used along the spatially constant boundaries.

108. The FUNCTION record is required for time-series data and defines the character of the forcing function driving the boundary. Variable FUNTYP on record FUNCTION is used to determine if the boundary is forced with harmonic constituents (HARMCNST), tabular elevation data (TABELEVS), or tabular discharge data (TABFLOWS). Variable FUNITS defines the units used for the given elevations or flows. The forcing function can be adjusted by shifting it in time (phase shift) or in the vertical (datum shift), or by multiplying the entire time-series by an adjustment factor. Variables FSHIFT,

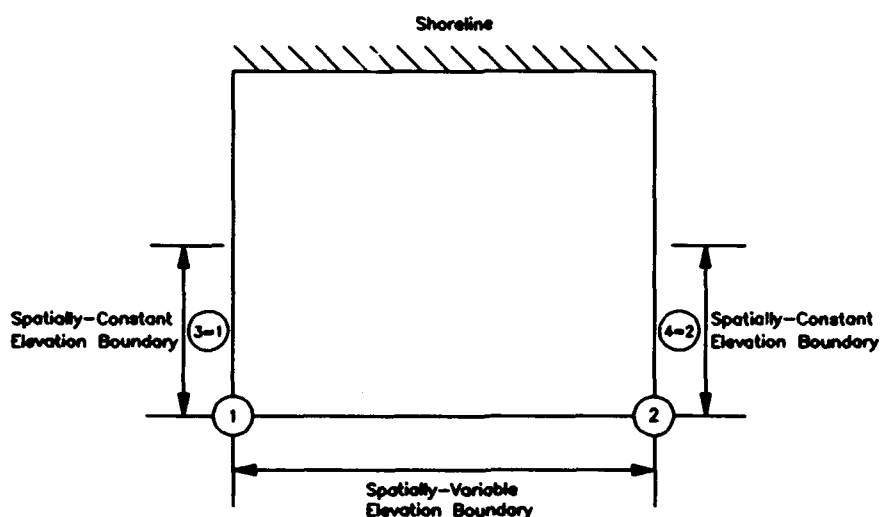

Figure 14-19. Example showing use of BDNFN1, BDNFN2, and FUNNO variables

FDATUM, and FMULT on record FUNCTION, respectively, are used to perform these tasks. The forcing function can be gradually spline-fit from initial conditions (usually zero) to the given function value over the time period assigned to variable FEATHR defined on record FUNCTION.

Harmonic constituents

109. A boundary driven with harmonic constituents (FUNTYP = HARMCNST) requires at least two records following the FUNCTION record: one CNRECORD record and at least one CONSTIT record. First, the CNRECORD record specifies the physical coordinates and timing associated with a constituent forcing function. The calendar date (variables RYEAR, RMONTH, and RDAY), time at the start of the simulation (variable RHOURL), and the west longitude of the grid cell where the forcing function is applied (RLONG) are specified on record CNRECORD. Dates and times can be referenced to Greenwich Mean Time (GMT) or local time. GMT is assumed if the longitude (RLONG) equals zero, and nonzero longitude values signal a local time specification. CNRECORD also contains variable RNAME for specifying a record name for the forcing function.

110. One CONSTIT record is needed for each constituent used in generating the time-series data. Variable CNAME on record CONSTIT defines which constituents are selected. Table 14-5 provides a list of the 37 constituents available. A maximum of 37 constituents can be selected (requiring 37 CONSTIT records) and are referenced with the naming convention developed by the National Ocean Survey. Variable CNAME on record CONSTIT is used to select any of the constituents listed in Table 14-5. Other data entered on this record include the constituent's amplitude (CAMP) and epoch (CEPOCH).

Tabular elevation time series

111. Tabular elevation data can be used to specify, or force, a boundary. WICM can access components of program TIDEGEN in package CMSUTIL (Appendix B of the 1991 edition of this manual) to internally compute the tabular elevation time-history data from tidal constituents. Each tabular tide boundary requires a TERECD to precede the actual water surface elevation data. The elevation data can be given at even (constant) time increments (RRINT = Real number) or at user-specified (irregular) times (RRINT = IRREGINT).

112. Constant time-interval data are entered as a one-dimensional array immediately following record TERECD. The time interval between entries is specified with variable RRINT (in TUNITS) on record TERECD. The total

Table 14-5

List of Available Constituents

<u>NOS Name</u>	<u>Description</u>
M2	Semidiurnal
S2	Semidiurnal
N2	Semidiurnal
K1	Diurnal
M4	Shallow-water quarter diurnal
O1	Diurnal
M6	Shallow-water sixth diurnal
MK3	Shallow-water terdiurnal
S4	Shallow-water quarter diurnal
MN4	Shallow-water quarter diurnal
NU2	Semidiurnal
S6	Shallow-water sixth diurnal
MU2	Semidiurnal
2N2	Semidiurnal
OO1	Diurnal
LAMBDA2	Semidiurnal
S1	Diurnal
M1	Diurnal
J1	Diurnal
MM	Long-period
SSA	Long-period
SA	Long-period
MSF	Long-period
MS	Long-period
RHO1	Diurnal
Q1	Diurnal
T2	Semidiurnal
R2	Semidiurnal
2Q1	Diurnal
P1	Diurnal
2SM2	Shallow-water semidiurnal
M3	Terdiurnal
L2	Semidiurnal
2MK3	Shallow-water terdiurnal
K2	Semidiurnal
M8	Shallow-water eighth diurnal
MS4	Shallow-water quarter diurnal

number of tabular elevation data entries in the one-dimensional array is specified with variable RENT. The user must also specify which of the array elements corresponds to the start of the simulation with variable RSTART. Typically, this element is the first value in the array. However, this variable must be updated for hotstart simulations. Variable RFORM is used to specify the format for reading the one-dimensional array, and variable RNAME is used for naming the tabular tide record.

113. For irregularly spaced (in time) tabular tide data, one TERECD and a series of TABELV records are required. Variable RRINT on record TERECD is set to IRREGINT for irregularly spaced (in time) tide data. The remaining variables on this record are ignored with this option.

114. One TABELV record is needed for each tabular tide entry. The elevation (FMAG in FUNITS) and time of occurrence (FHR, FMIN, FSEC in hours, minutes, and seconds) are required on each TABELV record. Elevations are linearly interpolated at those time-steps occurring between entries; therefore, at least two TABELV records are required. The first TABELV record must specify the elevation at or before the start of the simulation, whereas the last TABELV record must specify the elevation at or after the end of the simulation.

Tabular river discharge time series

115. River discharge boundary conditions can be specified at any interior grid cell face. An error message will be printed and execution terminated if this boundary condition is specified at an outer-boundary face. Furthermore, depths on opposite sides of the river boundary cell face must be greater than zero, signifying a water cell. Discharges are required to have units of flow per unit width (i.e. cubic feet/second/foot or cubic meters/second/meter).

116. Each river discharge boundary function requires one TFRECORD (analogous to the tabular tide function record (TERECD) discussed previously) to precede the flow data. The flow data can be given at even (constant) time increments (RRINT = real number), or at user-specified (irregular) times (RRINT = IRREGINT).

117. Constant time-interval data are entered as a one-dimensional array immediately following record TFRECORD. The time interval between entries is specified with variable RRINT (in TUNITS) on record TFRECORD. The total number of tabular flow data entries in the one-dimensional array is specified

with variable RENT. The user must also specify which of the array elements corresponds to the start of the simulation with variable RSTART. Typically this element is the first value in the array. However, this variable must be updated for hotstart simulations. Variable RFORM is used to specify the format for reading the one-dimensional array, and variable RNAME is used for naming the tabular flow record.

118. For irregularly spaced (in time) tabular flow data, one TFRECORD and a series of TABFLOW records are required. Variable RRINT on record TFRECORD is set to IRREGINT for irregularly spaced (in time) flow data. The remaining variables on this record are ignored with this option.

119. One TABFLOW record is needed for each tabular flow entry. The flow rate (FMAG in FUNITS) and time of occurrence (FHR, FMIN, FSEC in hours, minutes, and seconds) are required on each TABFLOW record. Flow rates are linearly interpolated at those time-steps occurring between entries; therefore, at least two TABFLOW records are required. The first TABFLOW record must specify the flow rate at or before the start of the simulation, whereas the last TABFLOW record must specify the flow rate at or after the end of the simulation.

Uniform flux boundary condition

120. The uniform flux boundary condition is similar to a river discharge boundary condition in that a flux is applied at the boundary cell face. However, the flux through the cell face is computed internally by the computer as opposed to specifying the flux for a river boundary. This boundary condition assumes that the flux through the boundary cell face is equal to the flux through the opposing cell face.

121. Since the UFBC does not drive a flow field, its application is limited. Therefore, care must be taken in applying it. Selecting an inappropriate reach (length) of the boundary may lead to erroneous results. The user should test the sensitivity of choice by trying other segment lengths that band the chosen reach.

Wind-Field Specifications

122. WICM can simulate hydrodynamics influenced by uniform, non-uniform, steady, and time-varying wind fields. However, wind-field calculations are only performed if record WINDSPEC and related records reside in the

input data set. Uniform (spatially and temporally constant) wind fields are specified by assigning character string UNIFSTRS or UNIFSPED to variable WNTRVL on record WINDSPEC. The WINDSPEC record is followed by one TABWINDS record specifying the x- and y-components of constant wind stress or speed (Table 14-6).

123. Nonuniform (spatially variable) wind fields are specified by assigning character string SPVRSTRS or SPVRSPED to variable WNTRVL on record WINDSPEC. The WINDSPEC record is followed by one TABWINDS record specifying the sequence (TSEQ) and format (TWFORM) of the wind-stress or wind-speed arrays, similar to the bathymetry sequence (BSEQ) and format (BFORM) (see Figure 14-15). The TABWINDS record is then followed by the wind-stress or wind-speed arrays.

124. Time-variable, spatially constant wind fields are specified by assigning character string TVRUNISP or TVRUNIST to variable WNTRVL on record WINDSPEC. The WINDSPEC record must be followed by at least two TABWINDS records that specify the x- and y-components of the wind stress or speed at specific times during the simulation.

125. Wind fields that vary in time and space are specified by assigning character string TSPVRSTR or TSPVRSPD to variable WNTRVL on record WINDSPEC. The WINDSPEC record is followed by at least two TABWINDS records, and each TABWINDS record is followed by wind-stress or wind-speed arrays.

126. For the time-variable uniform wind options, one TABWINDS record is typically entered for each hour of the simulation. (More frequent data rarely exist.) The model will then linearly interpolate to obtain wind-speed and direction values at the time interval specified by WINTRP on record WINDSPEC. It should be noted that WINTRP must be assigned a value that is an integer multiple of the time-step DT.

127. Variable WUNITS declares the system of units for wind magnitudes. Valid units are: (a) miles/hour, selected with character string MPH; (b) feet/second, chosen with FPS; (c) meters/second, specified with MPS; and (d) knots, selected with KNOTS.

128. Strong winds instantaneously applied to a static water basin, such as at the start of a simulation, will generate extraneous water oscillations that can lead to the model becoming unstable or can remain in the model solution for a significant portion of a simulation. These problems can be alleviated by gradually increasing wind magnitudes from zero at the start of

Table 14-6

Options for Wind-Field Specifications

Cases 1 and 2 Constant wind field with respect to time and space

WINDSPEC or TABWINDS	UNIFSTRS UNIFSPED	MPH	WINTRP		WIND DATA NAME
			TAUX	TAUY	

Cases 3 and 4 Spatially variable wind field

WINDSPEC or TABWINDS	SPVRSTRS SPVRSPED	MPH	WINTRP		WIND DATA NAME
					TSEQ TWFORM

(Array of TX1)
(Array of TY1)

Cases 5 and 6 Time-variable wind field

WINDSPEC or TABWINDS	TVRUNISP TVRUNIST	MPH	WINTRP		WIND DATA NAME
TABWINDS	IDAY(1)	Ihour(1)	TAUX(1)	TAUY(1)	
TABWINDS	IDAY(2)	Ihour(2)	TAUX(2)	TAUY(2)	
TABWINDS	IDAY(3)	Ihour(3)	TAUX(3)	TAUY(3)	

Cases 7 and 8 Time and spatially variable wind field

WINDSPEC or TABWINDS	TSPVRSTR TSPVRSPD	MPH	WINTRP		WIND DATA NAME
(Array of TX1) (Array of TY1)	IDAY(1)	Ihour(1)			TSEQ TWFORM
(Array of TX1) (Array of TY1)	IDAY(2)	Ihour(2)			

the simulation, to the actual magnitude several hours into the simulation. This task can be accomplished by adjusting wind magnitudes entered on the TABWINDS records.

129. All TABWINDS records must immediately follow the WINDSPEC record. Furthermore, times entered on these records must correspond to the simula-

tion's starting time defined by variable IT1 on record TIMESPEC. The first TABWINDS record must occur no later than the start of the simulation. For the time-variable option, the last TABWINDS record must occur no earlier than the end of the simulation.

130. For example, if the simulation begins at 0 hr 0 min and has a duration of 36 hr, the first TABWINDS record must specify wind conditions occurring at (or before) 0 hr 0 min, and the last record must occur at 36 hr 0 min (or later). Should the simulation be continued with the hotstart option, all times entered on the TABWINDS record are referenced to the original starting time. Assuming the hotstart begins at hour 36 and has a duration of 24 hr, the first TABWINDS record must have a time no later than 36 hr 0 min. The last TABWINDS record must have a time of 60 hr 0 min (or later).

Wave-Field Specifications

131. WICM can simulate hydrodynamics driven by steady, nonuniform, monochromatic or spectral wave fields. Wave stress calculations are performed only if record WAVESPEC resides in the input data set. Wave fields are specified by assigning character string RCPWAVE or STWAVE to variable WAVMODEL on record WAVESPEC. WAVMODEL specifies the type of wave input (monochromatic for RCPWAVE or spectral for STWAVE). Values of wave height, period, and direction for each grid cell follow the WAVESPEC record in the format produced by the RCPWAVE or STWAVE wave model. That is, if variable WAVMODEL is RCPWAVE, then WICM reads wave data in RCPWAVE output format. Similarly, if variable WAVMODEL is STWAVE, then WICM reads wave data in STWAVE output format.

132. Strong wave stress applied to a static water basin at the start of a simulation will generate extraneous water surface oscillations that can lead to the model becoming unstable or remain in the model solution for a significant portion of a simulation. These problems can be alleviated by gradually increasing the wave stress from zero at the start of the simulation to the actual magnitude over several time-steps. This task is accomplished by specifying the number of time-steps over which to build the wave stress to its actual value with variable IBUILD.

Output Specification

133. WICM provides several options for displaying output, including: (a) numerical gage time-histories at selected grid cells (e.g., elevations, wind, and/or water velocities), (b) wind or water velocity vector fields at user-specified times during a simulation, and (c) an output listing containing an input data summary and a printout of field arrays (e.g., free surface elevations, water velocities, wind velocities, bathymetry). CMSMODEL will prompt the user to provide a name for each specific output file (i.e., hydrograph file name for RECGAGE data, snapshot file name for field array (REC-SNAPS) data). These data files can be used as input to other hydrodynamic models as well as wave hindcast models contained within the CMS. Data can be displayed in either tabular or graphical form with the post-processing package CMSPOST discussed in Appendix C.

134. The output listing containing a summary of the input data set is generated for every simulation. Diagnostic error and warning messages are also contained in this listing. A sample output listing containing a summary of the input data set is presented in Figure 14-20.

135. Each input record is summarized in tabular form with a heading containing its record identification label followed by a brief description of that record's function. A table is composed of each variable's name, a description of that variable (including its units, when applicable), and an error diagnostic note.

136. WICM contains error diagnostic features that inspect an input data set for possible errors. These features include: (a) comparing an input value against a range of quantities that are representative for that variable, (b) checking for misspelled character data, and (c) checking for missing data. The error diagnostic note can be assigned one of three character strings, which are: (a) "FATAL" for errors where the model cannot execute given the value supplied, (b) "WARN" for data that are outside the range of values typically selected for that variable, and (c) a null string for instances where an error condition has not been identified. Although this model contains error diagnostic capabilities, the user should thoroughly inspect the input data summary to ensure that the data are correct.

137. Field arrays (e.g., free surface elevations, water velocities, wind velocities, bathymetry) are printed along with the input data summary by

COASTAL MODELING SYSTEM (CMS): WICM , VERSION 1.0

---- WICM SIMULATION NO. 1: PLANE BEACH, H=1.4M,T=4S,A=30DEG ----

***** GENSPES CARD: SPECIFICATION OF TITLE AND GENERAL SYSTEM OF UNITS

VARIABLE	DESCRIPTION OF USAGE:	VALUE:	NOTES:
UNITS	UNITS SYSTEM USED IN COMPUTATIONS	METRIC	

***** GRIDSPEC CARD: SPECIFICATION OF THE TYPE OF FINITE-DIFFERENCE GRID USED

VARIABLE	DESCRIPTION OF USAGE:	VALUE:	NOTES:
GRTYPE	TYPE OF FINITE-DIFFERENCE GRID	RECTANG	
GUNITS	SYSTEM OF UNITS USED FOR THE GRID	METRIC	
XCELL	NUMBER OF GRID CELLS, X DIRECTION	60	
YCELL	NUMBER OF GRID CELLS, Y DIRECTION	8	
ALXREF	TOTAL LENGTH IN X DIRECTION	900.	
ALYREF	TOTAL LENGTH IN Y DIRECTION	240.	

***** TIMESPEC CARD: SPECIFICATION OF COMPUTATIONAL TIME UNITS

VARIABLE	DESCRIPTION OF USAGE:	VALUE:	NOTES:
DELT	COMPUTATIONAL TIME STEP (SECONDS)	5.	
TUNITS	TIME UNITS FOR ALL INPUT VARIABLES	SECONDS	
IT1	TIMESTEP AT START OF MODEL SIMULATION	1	
IT2	TOTAL NUMBER OF TIMESTEPS SIMULATED	480	
NFREQ	TIMESTEP INTERVAL TO SAVE GAGE DATA	6	

***** ADDTERMS CARD: SPECIFICATION OF ADDITIONAL TERMS IN GOVERNING EQUATIONS

VARIABLE	DESCRIPTION OF USAGE:	VALUE:	NOTES:
ADVFLAG	GOVERNS USE OF ADVECTION TERMS	NO	
DIFFLAG	GOVERNS USE OF DIFFUSION TERMS	NO	
DIFCOF	DIFFUSION COEFFICIENT	0.0	
CORIOLIS	CORIOLIS COEFFICIENT	0.0	

Figure 14-20. Sample output listing

including one or more PRWINDOW records. Variable WPRVAR on record PRWINDOW is used to specify which field arrays are to be printed (e.g. WPRVAR = E for water surface elevations). The user can control printing of field arrays through the course of a simulation by specifying the starting (WPRSTR) and ending (WPREND) time-steps, together with the time interval (WPRINT), at which the data will be printed. Furthermore, the user can specify printing of subgrid regions (or windows) as opposed to the entire grid. This is done by specifying the x- and y-boundaries of a subgrid region with variables WXCEL1, WXCEL2, WYCEL1, and WYCEL2.

138. Gage time-histories of field arrays are saved with record RECGAGE. One RECGAGE record is required for each desired output location where the field array data are to be saved. A maximum of 120 gages, each containing up to 1,000 points, can be processed. All gage time-histories are stored in one file and are processed by programs HYDADD, HYDLST, and HYDPLT in package CMSPOST.

139. Variables IST and JST on record RECGAGE define the grid location where field arrays are saved. The time interval at which these data are stored is controlled by variable NFREQ on record TIMESPEC.

140. Record RECSNAPS allows the user to store wind and water velocity data for generating vector plots. The stored data can also be used as input to other models. Data can be saved at regular time intervals (SNPTYP = INTERVAL), at specific time-steps during a simulation (SNPTYP = TIMES), or both. For data storage at regular time intervals, SNPSTR defines the time-step at which data storage is to begin, SNPEND defines the time-step at which data storage is to end, and SNPINT is the regular time-step interval at which data storage occurs. For data storage at user-specified times, one RECSNAPS record is required for each time (SNPTIM) at which a snapshot is to be recorded. More than one RECSNAPS record can be used, and up to 100 snapshots can be saved in a file. These data can be processed with programs SNAPCON, SNAPLST, and SNAPVEC, which reside in package CMSPOST.

141. Records XRECRANG and YRECRANG allow the user to save data describing discharges across arbitrary transects. These data allow the user to check flow through various tributaries or to determine the tidal prism. One record is required for each desired transect. A maximum of 120 ranges, each containing up to 1,000 points, can be processed. All range time-histories are stored

in one file and are processed by programs HYDADD, HYDLST, and HYDPLT in package CMSPOST.

142. Similar to barriers and boundaries, variable RPOS1 defines the x-cell position (for XRECRANG) or the y-cell position where data are to be recorded. Variables RPOS2 and RPOS3 define the range, or extent, of the recording range location. For XRECRANG, records RPOS2 and RPOS3 indicate the y-extent, and for YRECRANG, records RPOS2 and RPOS3 indicate the x-extent. The time interval at which these data are stored is controlled by variable NFREQ on record TIMESPEC. RNAME is used to name the range data.

PART V: ILLUSTRATIVE EXAMPLES

143. Three illustrative examples are included in this section to demonstrate WICM's capabilities. The first example is a simple case of waves breaking on a plane beach. RCPWAVE is used to supply the input wave field. The other two examples involve application of WICM to Leadbetter Beach, CA, using wave fields calculated from both RCPWAVE and STWAVE. Examples demonstrating tidal forcing, wind-induced setup, and river discharge are given in Chapter 6 (CLHYD model).

Plane Beach Simulation

144. The plane beach simulation was executed on a 60- by 8-cell grid. The grid's spatial resolution was 15 m in the on-offshore (x-) direction and 30 m in the longshore (y-) direction for an overall grid size of 900 by 240 m. Water depth varied linearly from 0.15 m along the shoreline cells to 9.00 m at the offshore boundary. The duration of the simulation was 40 min.

145. The wave field was calculated with RCPWAVE for the plane beach simulation. RCPWAVE was run with input wave parameters of 1.4 m wave height, 4 sec period, and 30 deg wave angle. Bathymetric data used for RCPWAVE are the same as required for WICM (see Table 14-7). Figure 14-21 shows the wave height calculated from RCPWAVE and the plane beach profile. Wave height is approximately constant up to incipient breaking, then it decays rapidly. (Instructions for RCPWAVE implementation are given in Chapter 5.)

146. The WICM input data set is given in Table 14-7 and is discussed below. Wave input is specified by the WAVESPEC record (wave information from RCPWAVE, built from zero to the full value over 20 time-steps). Record FRICTABL specifies the constant friction coefficient. The location and type of boundary forcing functions are specified with XBOUNDRY and YBOUNDRY records. FUNCTION, TERECD, and TABELV records give specifics about the offshore boundary (elevations in tabular form). Record BATHSPEC is used to describe the bathymetric data, and RECGAGE records show the locations of the recording gages. The PRWINDOW record was used to print elevations and velocities for the entire grid to the output summary file at 10-min time intervals (120 time-steps).

Table 14-7

Input Data Set for the Plane-Beach Simulation

GENSPECS WICM SIMULATION NO. 1: PLANE BEACH, H=1.4M,T=4S,A=30DEG METRIC										
TIMESPEC	5.	SECONDS	1	480	6					
GRIDSPEC		METRIC	60	8	900.	240.	1.			
PRWINDOW					120					EV
ADDTERMS	NO	NO								
WAVESPEC	RCPWAVE		20							
RECGAGE	1		4							
RECGAGE	2		4							
RECGAGE	3		4							
RECGAGE	4		4							
.	.									
RECGAGE	45		4							
RECGAGE	50		4							
RECGAGE	55		4							
RECGAGE	59		4							
FRICTABL	0.01		10.0							
XBOUNDRY	CONSTELV		60	1	8	1				BDRYX
YBOUNDRY	UNIFLUX		1	1	59					BDRY1
YBOUNDRY	UNIFLUX		8	1	59					BDRY2
FUNCTION		1	TABELEV							
TERECORD	2		1	2400.						
TABELEV	0.0	0.0		0.0	0.0					
TABELEV	0.0	40.0		0.0	0.0					
BATHSPEC						YX	(8X,9F8.2)			
1	0.15	0.15	0.15	0.15	0.15	0.15	0.15	0.15	0.15	0.15
2	0.30	0.30	0.30	0.30	0.30	0.30	0.30	0.30	0.30	0.30
3	0.45	0.45	0.45	0.45	0.45	0.45	0.45	0.45	0.45	0.45
4	0.60	0.60	0.60	0.60	0.60	0.60	0.60	0.60	0.60	0.60
5	0.75	0.75	0.75	0.75	0.75	0.75	0.75	0.75	0.75	0.75
.	.									
57	8.55	8.55	8.55	8.55	8.55	8.55	8.55	8.55	8.55	8.55
58	8.70	8.70	8.70	8.70	8.70	8.70	8.70	8.70	8.70	8.70
59	8.85	8.85	8.85	8.85	8.85	8.85	8.85	8.85	8.85	8.85
60	9.00	9.00	9.00	9.00	9.00	9.00	9.00	9.00	9.00	9.00

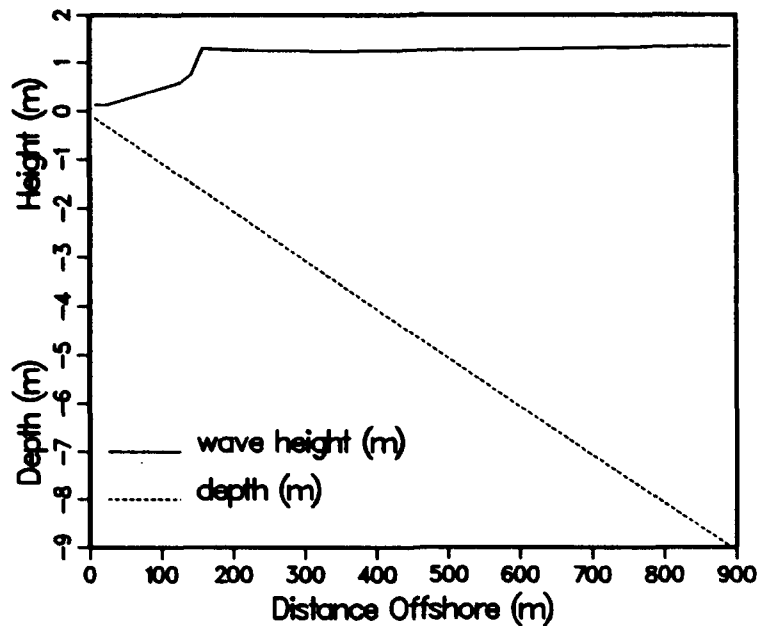

Figure 14-21. RCPWAVE results for plane beach simulation

147. The simulation was run for 480 time-steps of 5 sec each (40 min), and elevation and velocity values were saved every 6 time-steps at the 20 recording gage locations. At the conclusion of the simulation, calculated velocities and elevations were examined to check model results (Figures 14-22 and 14-23). The evolution of the water surface elevation and the cross-shore and longshore velocities with time at grid cell (10,4) are shown in Figure 14-22. Wave stress is built up over 20 time-steps (100 sec), and it takes approximately 240 time-steps for the solution to reach steady state. The small oscillations in S and U can be reduced by applying the wave forcing more gradually, but this is unnecessary if only steady-state results are required. Figure 14-23 shows S , U , and V for a cross-section of the grid for the final time-step. The cross-shore velocity is zero because the cross-shore wave stress is balanced by the water surface setup against the shoreline and the bathymetry is homogenous alongshore. The peak longshore velocity is 2.5 m/sec at the point of maximum wave height decay. The sharp discontinuity in the longshore current profile is due to the absence of diffusion ($A_H = 0.0$). The water surface elevation shows the typical depression (setdown) at the break point and superelevation (setup) near the shoreline.

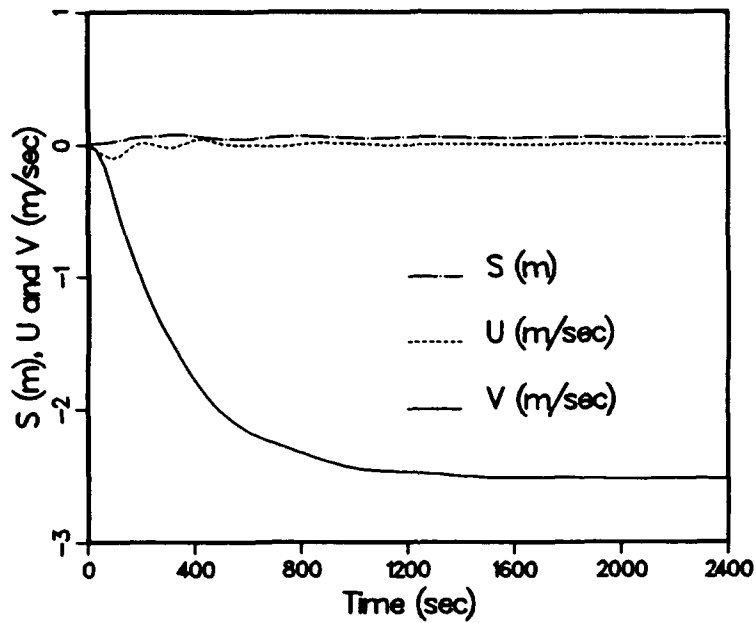

Figure 14-22. Time evolution of S, U, and V for plane beach simulation

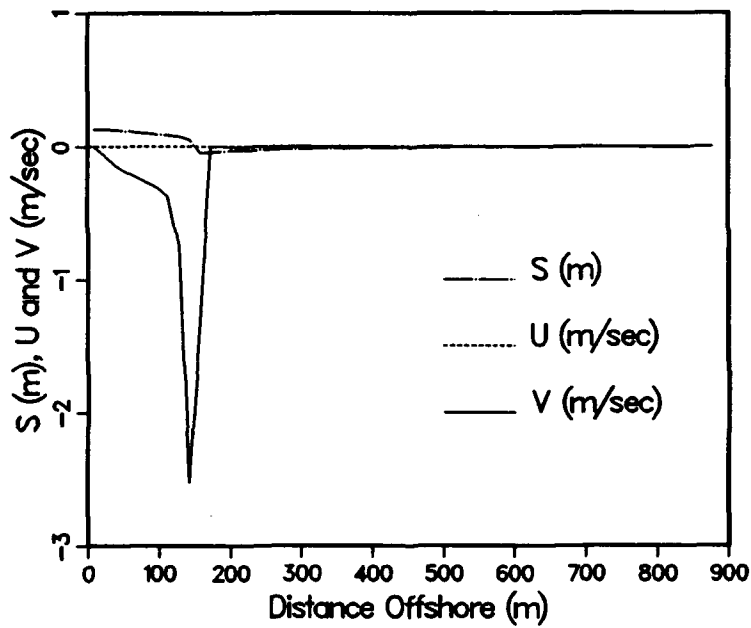

Figure 14-23. WICM results for plane beach simulation

148. In summary, a longshore current was simulated for monochromatic wave breaking on a plane beach, neglecting mixing. This simple example is a good test case for first-time users.

Leadbetter Beach, CA. Simulation with RCPWAVE

149. Leadbetter Beach, CA, was selected as an example because field data are available at this site from the National Sediment Transport Study (NSTS) (Thornton and Guza 1986) for model verification. This example uses data collected on 4 February 1980. NSTS data consist of root-mean-square wave height ($H_{rms} = 0.56$ m), peak period (14.2 sec), and mean direction (9.0 deg) measured at a water depth of 3.8 m for model input and wave height and longshore current measurements across the almost-plane profile at Leadbetter Beach. To apply the input wave conditions to RCPWAVE, the wave height and direction were linearly transformed to deep water using Snell's law, with H set equal to H_{rms} . Also, the incipient breaking criterion in RCPWAVE was changed to a height-to-depth ratio of 0.45. (RCPWAVE is formulated for incipient breaking of a monochromatic wave. Since a random wave field consists of a distribution of wave heights, a reasonable incipient breaking criterion is an H_{rms} -to-depth ratio of 0.4 to 0.5 (Thornton and Guza 1986).) The beach profile was assumed to be homogeneous in the alongshore direction. Figure 14-24 shows the beach profile and wave height across shore calculated from RCPWAVE.

150. A WICM grid was constructed with a 5-m grid spacing offshore (18 cells) and 10-m spacing alongshore (10 cells). A time-step of 3 sec was used, and the simulation length was 400 time-steps. Wave stress was built up over 20 time-steps. The bottom friction coefficient was set to 0.007 and the diffusion coefficient was set to 0.1. The WICM input data set is given in Table 14-8. Figure 14-25 shows the calculated velocities and surface elevations along across-shore row 5 at the end of the simulation. The lines represent model results and the symbols are longshore current measurements. The model longshore velocity results compare well with the measurements. The model was "calibrated" to the measurements by adjusting the friction factor and diffusion coefficient (within reasonable limits) to best fit the data. The current profile is much smoother in this example than in the plane beach simulation because diffusion is included.

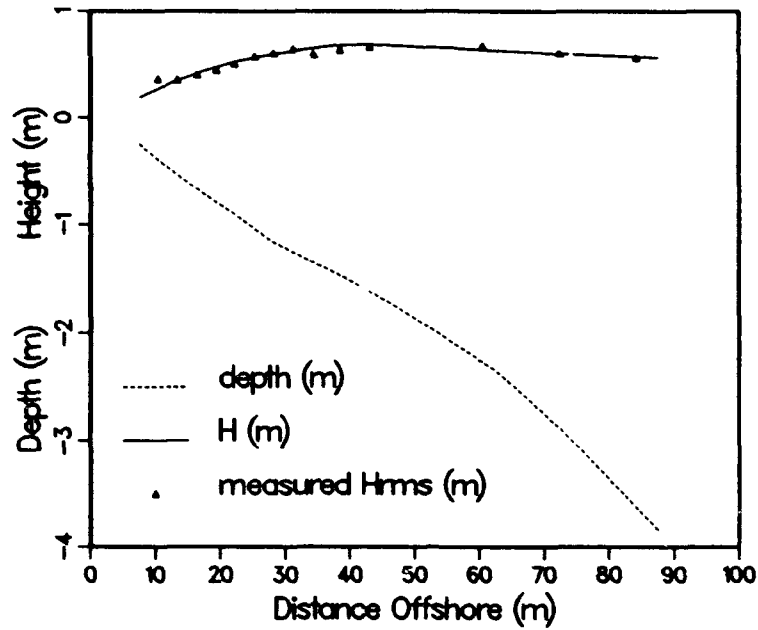

Figure 14-24. RCPWAVE results for Leadbetter Beach

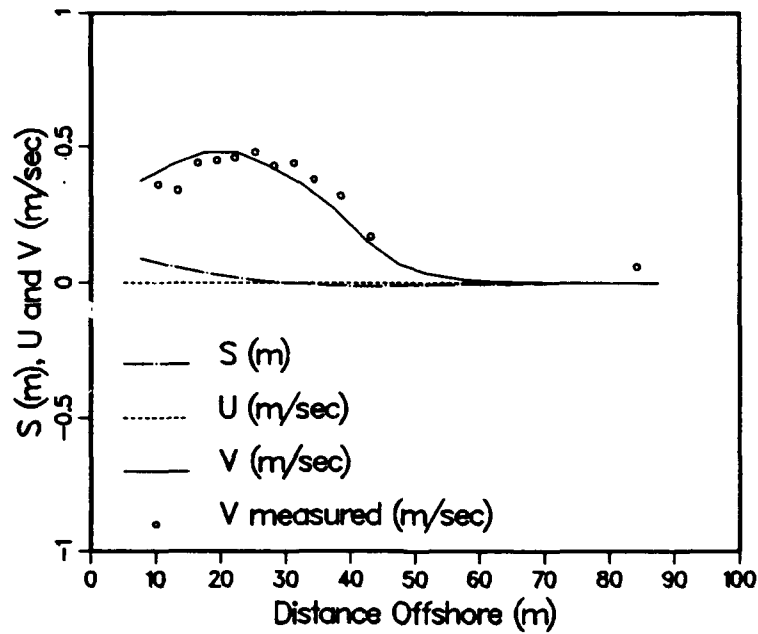

Figure 14-25. WICM results for Leadbetter Beach simulation (driven by RCPWAVE)

Table 14-8

Input Data Set for the Leadbetter Beach Simulation

WICM SIMULATION NO. 2: LEADBETTER, 4 OCT 1980, RCPWAVE										
GENSPECS	3. SECONDS		1	400	10					METRIC
TIMESPEC	METRIC		18	10	90.	100.	1.			
GRIDSPEC					100					EV
PRWINDOW										
ADDTERMS	NO	YES							0.1	
WAVESPEC	RCPWAVE								20	
RECGAGE	1	5								
RECGAGE	2	5								
RECGAGE	3	5								
RECGAGE	4	5								
.										
.										
RECGAGE	15	5								
RECGAGE	16	5								
RECGAGE	17	5								
RECGAGE	18	5								
FRICTABL	0.001	5.0								
XBOUNDRYCONSTELV		18	1	10	1			BDRYX		
YBOUNDRYUNIFLUX		1	1	17					BDRY1	
YBOUNDRYUNIFLUX		10	1	17					BDRY2	
FUNCTION	1TABELEV									
TERECORD	2	1	1200.							
TABELEV	0.0	0.0	0.0	0.0					0.0	
TABELEV	0.0	20.0	0.0	0.0					0.0	
BATHSPEC										
1	0.00	0.00	0.00	0.00	0.00	0.00	0.00	0.00	0.00	0.00
2	0.25	0.25	0.25	0.25	0.25	0.25	0.25	0.25	0.25	0.25
3	0.50	0.50	0.50	0.50	0.50	0.50	0.50	0.50	0.50	0.50
4	0.72	0.72	0.72	0.72	0.72	0.72	0.72	0.72	0.72	0.72
5	0.92	0.92	0.92	0.92	0.92	0.92	0.92	0.92	0.92	0.92
6	1.14	1.14	1.14	1.14	1.14	1.14	1.14	1.14	1.14	1.14
7	1.30	1.30	1.30	1.30	1.30	1.30	1.30	1.30	1.30	1.30
8	1.44	1.44	1.44	1.44	1.44	1.44	1.44	1.44	1.44	1.44
9	1.60	1.60	1.60	1.60	1.60	1.60	1.60	1.60	1.60	1.60
10	1.77	1.77	1.77	1.77	1.77	1.77	1.77	1.77	1.77	1.77
11	1.96	1.96	1.96	1.96	1.96	1.96	1.96	1.96	1.96	1.96
12	2.15	2.15	2.15	2.15	2.15	2.15	2.15	2.15	2.15	2.15
13	2.35	2.35	2.35	2.35	2.35	2.35	2.35	2.35	2.35	2.35
14	2.61	2.61	2.61	2.61	2.61	2.61	2.61	2.61	2.61	2.61
15	2.89	2.89	2.89	2.89	2.89	2.89	2.89	2.89	2.89	2.89
16	3.20	3.20	3.20	3.20	3.20	3.20	3.20	3.20	3.20	3.20
17	3.53	3.52	3.52	3.52	3.52	3.52	3.52	3.52	3.52	3.52
18	3.84	3.84	3.84	3.84	3.84	3.84	3.84	3.84	3.84	3.84

Leadbetter Beach, CA. Simulation with STWAVE

151. To apply the input wave conditions to STWAVE, the input H_{rms} measured at the depth of 3.8 m was multiplied by a factor of 1.4 to give the input energy-based wave height H_{mo} required by STWAVE (for a Rayleigh distribution of wave heights, $H_{mo} \approx 1.4 H_{rms}$ well outside the surf zone). Input wave period, wave direction, and bathymetric data were the same as used in the RCPWAVE simulation. Instructions for STWAVE implementation are given in Chapter 8. Figure 14-26 shows the beach profile and wave height across shore calculated from STWAVE. Note that the calculated wave height is H_{mo} and the measured wave height is H_{rms} in Figure 14-26, so it is expected that calculated values will exceed measured values.

152. The WICM grid used for this simulation is the same as discussed in paragraph 150. The WICM input data set is similar to the one given in Table 14-8, except "RCPWAVE" is replaced with "STWAVE" on the WAVESPEC record and the bottom friction coefficient is 0.006. Figure 14-27 shows calculated velocities and surface elevations along across-shore row 5 at the end of the simulation. The lines represent model results and the symbols are the longshore current measurements. Model results compare well with measurements.

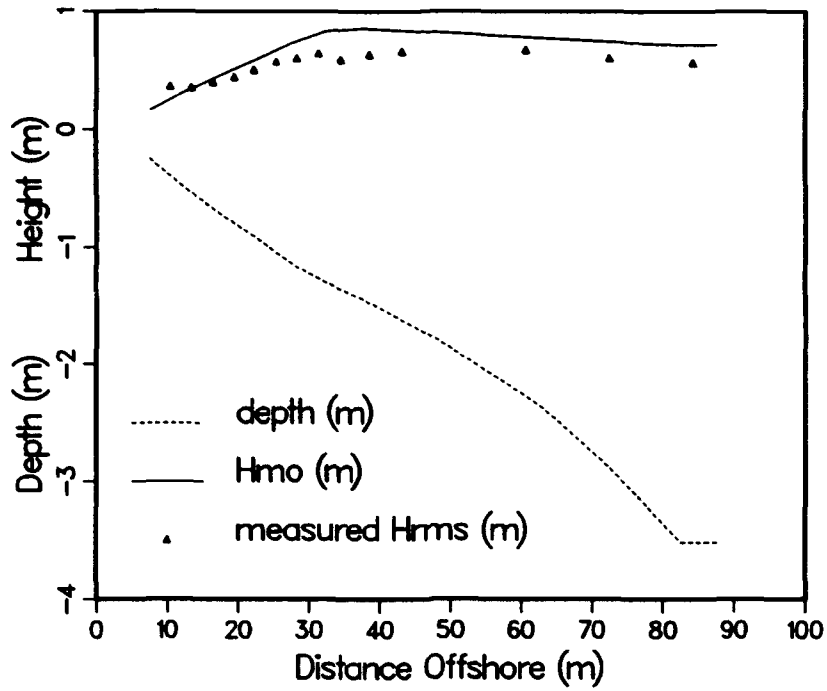

Figure 14-26. STWAVE results for Leadbetter Beach

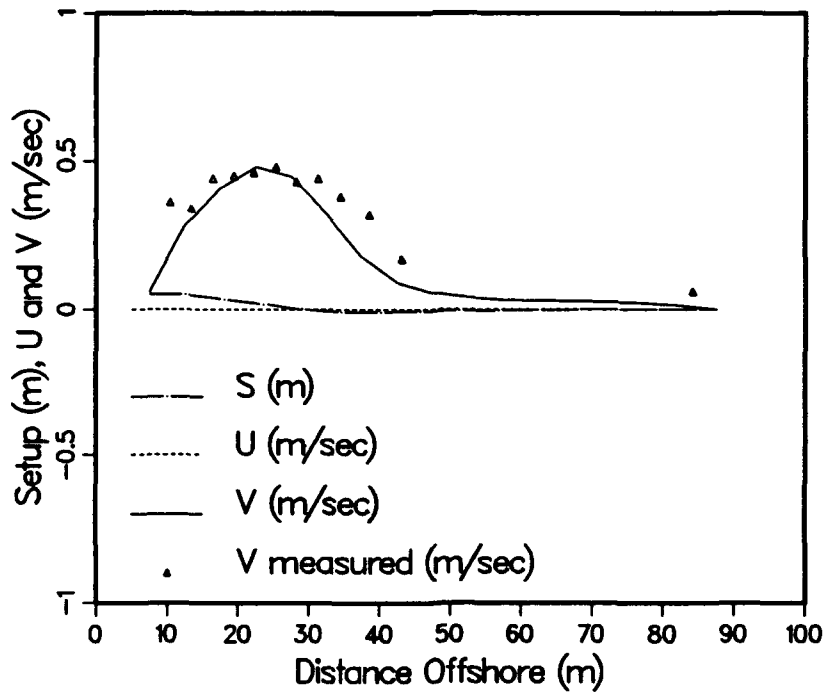

Figure 14-27. WICM results for Leadbetter Beach simulation (driven by STWAVE)

REFERENCES

- Bowen, A. J. 1969. "The Generation of Longshore Currents on a Plane Beach," Journal of Marine Research, Vol 73, No. 8, pp 2569-2577.
- Ebersole, B. A., and Dalrymple, R. A. 1979. "A Numerical Model for Nearshore Circulation Including Convective Accelerations and Lateral Mixing," Ocean Engineering Report No. 21, University of Delaware, 87 p.
- Garratt, J. R. 1977. "Review of Drag Coefficients Over Oceans and Continents," Monthly Weather Review, Vol 106, pp 915-929.
- Harris, D. L., and Bodine, B. R. 1977. "Comparison of Numerical and Physical Hydraulic Models, Masonboro Inlet, North Carolina," GITI Report 6, US Army Engineer Waterways Experiment Station, Coastal Engineering Research Center, Vicksburg, MS.
- Horikawa, K. 1988. Nearshore Dynamics and Coastal Processes Theory, Measurement and Predictive Models, University of Tokyo Press, Tokyo, Japan.
- Johnson, B. H. 1982. "Numerical Modeling of Estuarine Hydrodynamics on a Boundary-Fitted Coordinate System," Numerical Grid Generation Foundations and Applications, J. Thompson, ed., Elsevier Science Publishing Co., Inc., pp 409-436.
- Keely, J. R., and Bowen, A. J. 1977. "Longshore Variation in Longshore Currents," Canadian Journal of Earth Science, Vol 14, No. 8, pp 1897-1905.
- Longuet-Higgins, M. S. 1970a. "Longshore Currents Generated by Obliquely Incident Sea Waves, 1," Journal of Geophysical Research, Vol 75, No. 33, pp 6778-6789.
- _____. 1970b. "Longshore Currents Generated by Obliquely Incident Sea Waves, 2," Journal of Geophysical Research, Vol 75, No. 33, pp 6790-6801.
- Longuet-Higgins, M. S., and Stewart, R. W. 1962. "Radiation Stress and Mass Transport in Gravity Waves, with Application to 'Surf Beats'," Journal of Fluid Mechanics, Vol 13, No. 4, pp 481-504.
- _____. 1963. "A Note on Wave Setup," Journal of Marine Research, Vol 21, No. 1, pp 4-10.
- _____. 1964. "Radiation Stress in Water Waves; A Physical Discussion with Applications," Deep Sea Research, Vol 11, No. 4, pp 529-562.
- Roache, P. J. 1976. Computational Fluid Dynamics, Hermosa Publishers, Albuquerque, NM.
- Sheng, Y. P. 1986. "A Three-Dimensional Mathematical Model of Coastal, Estuarine, and Lake Currents Using Boundary Fitted Grid," A.R.A.P. Report No. 585, Aeronautical Research Associates of Princeton, Inc., Princeton, NJ.

Thomas, L. H. 1949. "Elliptic Problems in Linear Difference Equations Over a Network," Watson Sci Computer Lab Report, Columbia University, New York.

Thompson, J. F. 1983. "A Boundary-Fitted Coordinate Code for General Two-Dimensional Regions with Obstacles and Boundary Intrusions," Technical Report E-83-8, US Army Engineer Waterways Experiment Station, Vicksburg, MS.

Thompson, J. F., Warsi, Z. U. A., and Mastin, C. W. 1985. Numerical Grid Generation Foundations and Applications, Elsevier Science Publishing Co., Inc., New York.

Thornton, E. B. 1970. "Variation of Longshore Current Across the Surf Zone," Proceedings of the 12th Coastal Engineering Conference, American Society of Civil Engineers, pp 291-308.

Thornton, E. B., and Guza, R. T. 1986. "Surf Zone Longshore Currents and Random Waves: Field Data and Models," Journal of Physical Oceanography, American Meteorological Society, Vol 16, pp 1165-1178.

Vemulakonda, S. R. 1984. "Erosion Control of Scour During Construction; Report 7: CURRENT -- A Wave-Induced Current Model," Technical Report HL-80-3, US Army Engineer Waterways Experiment Station, Vicksburg, MS.

Weare, T. J. 1979. "Errors Arising from Irregular Boundaries in ADI Solutions of the Shallow-Water Equations," International Journal for Numerical Methods in Engineering, Vol 14, pp 921-931.

Wind, H. G., and Vreugdenhil, C. B. 1986. "Rip-current Generation Near Structures," Journal of Fluid Mechanics, Vol 171, pp 459-476.

APPENDIX 14-A: TRANSFORMATION OF ADVECTION AND DIFFUSION TERMS

The advective (inertia) terms in the x- and y-momentum equations are given as:

X-Momentum

$$\frac{\partial}{\partial x} \left(\frac{UU}{H} \right) + \frac{\partial}{\partial y} \left(\frac{UV}{H} \right)$$

Y-Momentum

$$\frac{\partial}{\partial x} \left(\frac{UV}{H} \right) + \frac{\partial}{\partial y} \left(\frac{VV}{H} \right)$$

These expressions are represented in the transformed plane as:

X-Momentum

$$\begin{aligned} & \frac{\partial x}{\partial \eta} \left[U \frac{\partial}{\partial \xi} \left(\frac{U}{H} \frac{\partial y}{\partial \xi} + \frac{V}{H} \frac{\partial y}{\partial \eta} \right) \sqrt{g_s} + V \frac{\partial}{\partial \eta} \left(\frac{U}{H} \frac{\partial y}{\partial \xi} + \frac{V}{H} \frac{\partial y}{\partial \eta} \right) \sqrt{g_v} \right] \\ & + \frac{\partial y}{\partial \eta} \left[U \frac{\partial}{\partial \xi} \left(\frac{U}{H} \frac{\partial x}{\partial \xi} + \frac{V}{H} \frac{\partial x}{\partial \eta} \right) \sqrt{g_s} + V \frac{\partial}{\partial \eta} \left(\frac{U}{H} \frac{\partial x}{\partial \xi} + \frac{V}{H} \frac{\partial x}{\partial \eta} \right) \sqrt{g_v} \right] \end{aligned}$$

Y-Momentum

$$\begin{aligned} & \frac{\partial x}{\partial \xi} \left[U \frac{\partial}{\partial \xi} \left(\frac{U}{H} \frac{\partial y}{\partial \xi} + \frac{V}{H} \frac{\partial y}{\partial \eta} \right) \sqrt{g_u} + V \frac{\partial}{\partial \eta} \left(\frac{U}{H} \frac{\partial y}{\partial \xi} + \frac{V}{H} \frac{\partial y}{\partial \eta} \right) \sqrt{g_s} \right] \\ & - \frac{\partial y}{\partial \xi} \left[U \frac{\partial}{\partial \xi} \left(\frac{U}{H} \frac{\partial x}{\partial \xi} + \frac{V}{H} \frac{\partial x}{\partial \eta} \right) \sqrt{g_u} + V \frac{\partial}{\partial \eta} \left(\frac{U}{H} \frac{\partial x}{\partial \xi} + \frac{V}{H} \frac{\partial x}{\partial \eta} \right) \sqrt{g_s} \right] \end{aligned}$$

Finite Difference Representation

The upwind treatment of the advective terms, otherwise known as the "pigpen method" (Roache 1976), is implemented in the WICM model. In this formulation, the effect of a perturbation is carried only in the direction of

the velocity. D. B. Spalding called this the pigpen method because a concentrated quantity would be "smelled" only downwind of the source. This translates into the model as meaning that a point in the grid is affected only by what occurs upwind of it. Advantages of this method are its simplicity in formulation and stability of the solution due to its diffusive nature. The stability can also act as a disadvantage if the diffusion becomes excessive.

X-Momentum

For flow in the positive x-direction, the finite differences are taken between cells $i-1$ and i in accordance with the pigpen method:

$$\begin{aligned} & \frac{-\frac{\partial x}{\partial \eta}}{g_x H} \left[\frac{U \left(\frac{U}{H} \frac{\partial y}{\partial \xi} + \frac{\bar{V}}{H} \frac{\partial y}{\partial \eta} \right) \sqrt{g_x} \Big|_i - U \left(\frac{U}{H} \frac{\partial y}{\partial \xi} + \frac{\bar{V}}{H} \frac{\partial y}{\partial \eta} \right) \sqrt{g_x} \Big|_{i-1}}{\Delta \xi} \right. \\ & \left. + \frac{\bar{V} \left(\frac{U}{H} \frac{\partial y}{\partial \xi} + \frac{\bar{V}}{H} \frac{\partial y}{\partial \eta} \right) \sqrt{g_v} \Big|_{j+\frac{1}{2}} - \bar{V} \left(\frac{U}{H} \frac{\partial y}{\partial \xi} + \frac{\bar{V}}{H} \frac{\partial y}{\partial \eta} \right) \sqrt{g_v} \Big|_{j-\frac{1}{2}}}{\Delta \eta} \right] \\ & + \frac{\frac{\partial y}{\partial \eta}}{g_x H} \left[\frac{U \left(\frac{U}{H} \frac{\partial x}{\partial \xi} + \frac{\bar{V}}{H} \frac{\partial x}{\partial \eta} \right) \sqrt{g_x} \Big|_i - U \left(\frac{U}{H} \frac{\partial x}{\partial \xi} + \frac{\bar{V}}{H} \frac{\partial x}{\partial \eta} \right) \sqrt{g_x} \Big|_{i-1}}{\Delta \xi} \right. \\ & \left. + \frac{\bar{V} \left(\frac{U}{H} \frac{\partial x}{\partial \xi} + \frac{\bar{V}}{H} \frac{\partial x}{\partial \eta} \right) \sqrt{g_v} \Big|_{j+\frac{1}{2}} - \bar{V} \left(\frac{U}{H} \frac{\partial x}{\partial \xi} + \frac{\bar{V}}{H} \frac{\partial x}{\partial \eta} \right) \sqrt{g_v} \Big|_{j-\frac{1}{2}}}{\Delta \eta} \right] \end{aligned}$$

For flow in the negative x-direction, the finite differences are taken between cells $i+1$ and i in accordance with the pigpen method, and the equations are similar to those shown above.

Y-Momentum

For flow in the positive y-direction, finite differences are taken between cells $j-1$ and j in accordance with the pipepen method:

$$\begin{aligned} & \frac{\partial x}{\partial \xi} \left[\frac{\bar{U} \left(\frac{\bar{U}}{H} \frac{\partial y}{\partial \xi} + \frac{V}{H} \frac{\partial y}{\partial \eta} \right) \sqrt{g_x}}{\Delta \xi} \Big|_{i+\eta} - \bar{U} \left(\frac{\bar{U}}{H} \frac{\partial y}{\partial \xi} + \frac{V}{H} \frac{\partial y}{\partial \eta} \right) \sqrt{g_x} \Big|_{i-\eta} \right. \\ & \left. + \frac{V \left(\frac{\bar{U}}{H} \frac{\partial y}{\partial \xi} + \frac{V}{H} \frac{\partial y}{\partial \eta} \right) \sqrt{g_x}}{\Delta \eta} \Big|_j - V \left(\frac{\bar{U}}{H} \frac{\partial y}{\partial \xi} + \frac{V}{H} \frac{\partial y}{\partial \eta} \right) \sqrt{g_x} \Big|_{j-1} \right] \\ & - \frac{\partial y}{\partial \xi} \left[\frac{\bar{U} \left(\frac{\bar{U}}{H} \frac{\partial x}{\partial \xi} + \frac{V}{H} \frac{\partial x}{\partial \eta} \right) \sqrt{g_x}}{\Delta \xi} \Big|_{i+\eta} - \bar{U} \left(\frac{\bar{U}}{H} \frac{\partial x}{\partial \xi} + \frac{V}{H} \frac{\partial x}{\partial \eta} \right) \sqrt{g_x} \Big|_{i-\eta} \right. \\ & \left. + \frac{V \left(\frac{\bar{U}}{H} \frac{\partial x}{\partial \xi} + \frac{V}{H} \frac{\partial x}{\partial \eta} \right) \sqrt{g_x}}{\Delta \eta} \Big|_j - V \left(\frac{\bar{U}}{H} \frac{\partial x}{\partial \xi} + \frac{V}{H} \frac{\partial x}{\partial \eta} \right) \sqrt{g_x} \Big|_{j-1} \right] \end{aligned}$$

Diffusion

Diffusion terms in the x- and y-momentum equations are given as:

X-Momentum

$$A_H \left(\frac{\partial^2 U}{\partial x^2} + \frac{\partial^2 U}{\partial y^2} \right)$$

Y-Momentum

$$A_{\#} \left(\frac{\partial^2 V}{\partial x^2} + \frac{\partial^2 V}{\partial y^2} \right)$$

These expressions are represented in the transformed plane as:

X-Momentum

$$\begin{aligned} & U_{\xi\xi} H_{11} + 2U_{\xi\eta} H_{12} + U_{\eta\eta} H_{22} \\ & + (D_{11}^1 U)_{\xi} H_{11} + (D_{11}^1 U)_{\eta} H_{12} + (D_{12}^1 U)_{\xi} H_{12} + (D_{12}^1 U)_{\eta} H_{22} \\ & + (D_{12}^1 V)_{\xi} H_{11} + (D_{12}^1 V)_{\eta} H_{12} + (D_{22}^1 V)_{\xi} H_{12} + (D_{22}^1 V)_{\eta} H_{22} \\ & - U_{\xi} (D_{12}^1 H_{12} + D_{22}^1 H_{22}) \\ & + U_{\eta} (D_{11}^1 H_{12} + D_{12}^1 H_{22} - D_{11}^2 H_{11} - 2D_{12}^2 H_{12} - D_{22}^2 H_{22}) \\ & + V_{\xi} (D_{12}^1 H_{11} + D_{22}^1 H_{12}) + V_{\eta} (D_{12}^1 H_{12} + D_{22}^1 H_{22}) \\ & + [(D_{12}^1 D_{12}^1 + D_{22}^1 D_{12}^2 - D_{22}^1 D_{11}^1 - D_{22}^2 D_{12}^1) H_{22} - (D_{12}^1 D_{12}^2 - D_{11}^2 D_{22}^1) H_{12}] U \\ & + [(D_{12}^1 D_{12}^2 - D_{11}^2 D_{22}^1) H_{11} - (D_{12}^1 D_{12}^1 + D_{22}^1 D_{12}^2 - D_{22}^1 D_{11}^1 - D_{22}^2 D_{12}^1) H_{12}] V \end{aligned}$$

where

$$\begin{aligned} U_{\xi} &= \frac{\partial U}{\partial \xi} & V_{\xi} &= \frac{\partial V}{\partial \xi} \\ U_{\eta} &= \frac{\partial U}{\partial \eta} & V_{\eta} &= \frac{\partial V}{\partial \eta} \\ U_{\xi\xi} &= \frac{\partial^2 U}{\partial \xi^2} & V_{\xi\xi} &= \frac{\partial^2 V}{\partial \xi^2} \\ U_{\xi\eta} &= \frac{\partial^2 U}{\partial \xi \partial \eta} & V_{\xi\eta} &= \frac{\partial^2 V}{\partial \xi \partial \eta} \\ U_{\eta\eta} &= \frac{\partial^2 U}{\partial \eta^2} & V_{\eta\eta} &= \frac{\partial^2 V}{\partial \eta^2} \end{aligned}$$

H_{ij} = inverse metric tensor components

D_{ij}^k = Christoffel symbols of the second kind

$(D_{ij}U)_\xi$ = derivative with respect to ξ

$(D_{ij}U)_\eta$ = derivative with respect to η

$(D_{ij}V)_\xi$ = derivative with respect to ξ

$(D_{ij}V)_\eta$ = derivative with respect to η

Y-Momentum

$$\begin{aligned} & V_{\xi\xi}H_{11} + 2V_{\xi\eta}H_{12} + V_{\eta\eta}H_{22} \\ & + (D_{11}^2U)_\xi H_{11} + (D_{11}^2U)_\eta H_{12} + (D_{12}^2U)_\xi H_{12} + (D_{12}^2U)_\eta H_{22} \\ & + (D_{12}^2V)_\xi H_{11} + (D_{12}^2V)_\eta H_{12} + (D_{22}^2V)_\xi H_{12} + (D_{22}^2V)_\eta H_{22} \\ & + U_\xi(D_{11}^2H_{11} + D_{12}^2H_{12}) + U_\eta(D_{11}^2H_{12} + D_{12}^2H_{22}) \\ & + V_\xi(D_{12}^2H_{11} + D_{22}^2H_{12} - D_{11}^1H_{11} - 2D_{12}^1H_{12} - D_{22}^1H_{22}) \\ & - V_\eta(D_{11}^2H_{11} + D_{12}^2H_{12}) \\ & + [(D_{12}^2D_{11}^1 + D_{22}^2D_{11}^2 - D_{12}^1D_{11}^2 - D_{12}^2D_{12}^2)H_{12} + (D_{11}^2D_{22}^1 - D_{12}^1D_{12}^2)H_{22}]U \\ & + [(D_{11}^2D_{22}^1 - D_{12}^1D_{12}^2)H_{12} + (D_{12}^2D_{11}^1 + D_{22}^2D_{11}^2 - D_{12}^1D_{11}^2 - D_{12}^2D_{12}^2)H_{11}]V \end{aligned}$$

Treatment of the advective and diffusive terms is different near boundaries. The velocity cross derivative is assumed to be zero near the boundary, and a slip condition exists. This "slip" boundary is assumed for both the advection and diffusion terms.

APPENDIX 14-B: WIGM DATA SPECIFICATION RECORDS

Model Control Specifications

(Req)	GENSPECS	Specify general title and system of units
(Req)	TIMESPEC	Specify time-related controlling variables
(Opt)	ADDTERMS	Specify optional terms in governing equations
(Opt)	STARTUP	Specify initial conditions

Grid Description

(Req)	GRIDSPEC	Specify general grid characteristics
(C-Opt)	GRIDCORN	Specify x- and y corner points for grid
(C-Opt)	XSTRETCH	Specify x-coordinates to create stretched grid
(C-Opt)	YSTRETCH	Specify y-coordinates to create stretched grid

Physical Characteristics

(Req)	BATHSPEC	Specify characteristics of bathymetry/topography
(Req)	--	Two-dimensional array of bathymetric/topographic data
(Opt)	CHNGBATH	Specify changes to the bathymetric/topographic data
(Opt)	XBARRIER	Specify barrier perpendicular to x-axis
(Opt)	YBARRIER	Specify barrier perpendicular to y-axis
(Opt)	FRICITION	Specify character of bottom friction
(Opt)	FRICTABL	Specify entry for depth-variable friction table
(Opt)	CHNGFRIC	Modify the friction values at selected locations

Boundary Conditions

(Opt)	XBOUNDARY	Specify driving boundary perpendicular to x-axis
(Opt)	YBOUNDARY	Specify driving boundary perpendicular to y-axis
(C-Opt)	FUNCTION	Specify driving boundary forcing function
(C-Opt)	CNRECORD	Specify attributes of constituent forcing
(C-Opt)	CONSTIT	Specify harmonic constituent forcing function
(C-Opt)	TERECORD	Specify attributes of tabular elevation forcing
(C-Opt)	TFRECORD	Specify attributes of tabular velocity forcing
(C-Opt)	TABELEV	Specify irregularly spaced tabular elevations

(C-Opt) TABFLOW Specify irregularly spaced tabular velocities

Wind-Field Specifications

(Opt) WINDSPEC Specify the character of wind-field data

(C-Opt) TABWINDS Specify wind-field tabular data

Wave-Field Specifications

(Opt) WAVESPEC Specify the character of wave-field data

Output Specifications

(Req) PRWINDOW Specify location and timing of a print window

(Opt) RECGAGE Specify location of recording gage in grid

(Opt) RECSNAPS Specify snapshot time(s) for recording

(Opt) XRECRANG Specify discharge range perpendicular to x-axis

(Opt) YRECRANG Specify discharge range perpendicular to y-axis

CMS Data Specification: GENSPECS Record: (Req)
 Purpose: Specify general title and system of units.

Field	Variable	Type	Status	Default	Permitted Data	Usage
1	CARDID	Char *8	(Req)		GENSPECS	Record identifier.
2-9	TITLE	Char *64	(Opt)		A*	General title for simulation.
10	SUNITS	Integer	(Opt)	ENGLISH	ENGLISH METRIC	Declares the system of units for model computations and results.
					UNIT	ENGLISH METRIC
					(SI)	(British)
					Length	ft m
					Time	sec sec
					Velocity	ft/sec m/sec
					Discharge	cu ft/sec cu m/sec
					Pressure	ft (of water) m (of water)

CMS Data Specification: **TIMESPEC Record: (Req)**
 Purpose: Specify time-related controlling variables.

Field	Variable	Type	Status	Default	Permitted Data	Usage
1	CARDID	Char *8	(Req)		TIMESPEC	Record Identifier.
2	DT	Real	(Req)		+R*	Time step for simulation (secs).
3	TUNITS	Char *8	(Opt)	HOURS	HOURS MINUTES SECONDS	Units for all time variables (except where noted).
4	IT1	Integer	(Opt)	1	+I*	Provisional model timestep at the start of the simulation.
5	IT2	Integer	(Opt)	1	+I*	Length of simulation (in timesteps).
6	NFREQ	Integer	(Opt)		+I*	Time interval (in timesteps) for recording time history data (water velocities and free surface elevations)
7	ITBRKINC	Integer	(Opt)	IT2	+I*	Time interval (in timesteps) for saving HOTSTART data.

CMS Data Specification: ADDTERMS Record: (Opt)
 Purpose: Specify optional terms in governing equations.

Field	Variable	Type	Status	Default	Permitted	Usage
		Char #8	(Req)		Data	Record Identifier.
					ADDTERMS	
1	CARDID	Char #8	(Req)			
2	ADVFLAG	Char #8	(Opt)	NO	NO YES	No advective (inertial) terms. Advective terms to be included.
3	DIFFLAG	Char #8	(Opt)	NO	NO YES	No diffusion (eddy viscosity) terms. Diffusion terms to be included.
4	AH	Real	(C-opt)	0.	+R*	The diffusion coefficient (required if YES specified for DIFFLAG).
5	COR	Real	(Opt)	0.	+R*	Coriolis coefficient.

Notes:
 (1) All terms on this record are omitted from the Governing Equations if this record is omitted.

CMS Data Specification: STARTUP Record: (Opt)
 Purpose: Specify initial conditions.

Field	Variable	Type	Status	Default	Permitted Data	Usage
1	CARDID	Char *8	(Req)		STARTUP	Record identifier.
2	SELEV	Real	(Opt)	0.	R*	Initial water surface elevation levels. Velocities are initialized to zero.
		(or) Char *8			HOTSTART	Field variables (S, u, and v) to be read to start simulation.
3	SECHO	Char *8	(Opt)	SHORT	SHORT DETAILED	Short report of input and preliminary data to be written. Full (detailed) report of input and preliminary data to be written.
4-10	SNAME	Char *56	(Opt)		A*	Name of startup conditions.

CMS Data Specification: GRIDSPEC Record: (Req)
 Purpose: Specify general computational grid characteristics.

Field	Variable	Type	Status	Default	Permitted Data	Usage
1	CARDID	Char #8	(Req)		GRIDSPEC	Record identifier.
2	GRTYPE	Char #8	(Opt)	RECTANG	RECTANG	Cartesian system with constant-spaced grid cells.
					RSTRETCH	Cartesian system with stretching function employed to create grid cells. (requires XSTRETCH and YSTRETCH records after the GRIDSPEC).
					CURVILIN	Curvilinear grid system (requires GRIDCORN record after the GRIDSPEC).
3	GUNITS	Char #8	(Opt)	ENGLISH	ENGLISH METRIC	System of units for grid data.
4	ICELLS	Integer	(Req)		+I*	Number of grid cells in x-direction.
5	JCELLS	Integer	(Req)		+I*	Number of grid cells in y-direction.
6	ALXREF	Real	(Req)		+R*	Overall length of grid in x-direction (in GUNITS).
7	ALYREF	Real	(Req)		+R*	Overall length of grid in y-direction (in GUNITS).
8	XMAP	Real	(Req)		R*	Map scale.

CMS Data Specification: GRIDCORN Record: (C-opt)

Purpose: Specify general characteristics of the curvilinear grid coordinate data.

<u>Field</u>	<u>Variable</u>	<u>Type</u> Char #8	<u>Status</u> (Req)	<u>Default</u>	<u>Permitted Data</u> GRIDCORN	<u>Usage</u> Record Identifier.
1	CARDID					
2	CSEQ	Char #8	(Opt)	XY	XY -XY X-Y -X-Y YX -YX Y-X -Y-X	The 2-d array of grid coordinate data which follows this record, is read in a sequence specified by this mnemonic code (see notes for the conventions represented by these mnemonics).
3-4	CFORM	Char #16	(Opt)	(8G10.3)	A*	Format used to read the following 2-d array of grid coordinate data.

(Continued)

(Concluded)

Notes:

(1) Conventions for 2-d array read sequence mnemonics:

```
***** SEQ - XY *****
DO 1 J-1, JCELLS+1
1 READ(LUN, FORM) (XCT(I, J), I-1, ICELLS+1)
DO 11 J-1, JCELLS+1
11 READ(LUN, FORM) (YCT(I, J), I-1, ICELLS+1)

***** SEQ - -XY *****
DO 2 J-1, JCELLS+1
2 READ(LUN, FORM) (XCT(I, J), I-1, ICELLS+1, 1, -1)
DO 12 J-1, JCELLS+1
12 READ(LUN, FORM) (YCT(I, J), I-1, ICELLS+1, 1, -1)

***** SEQ - X-Y *****
DO 3 J-JCELLS+1, 1, -1
3 READ(LUN, FORM) (XCT(I, J), I-1, ICELLS+1)
DO 13 J-JCELLS+1, 1, -1
13 READ(LUN, FORM) (YCT(I, J), I-1, ICELLS+1)
***** SEQ --X-Y *****
DO 4 J-JCELLS+1, 1, -1
4 READ(LUN, FORM) (XCT(I, J), I-1, ICELLS+1, 1, -1)
DO 14 J-JCELLS+1, 1, -1
14 READ(LUN, FORM) (YCT(I, J), I-1, ICELLS+1, 1, -1)

***** SEQ - YX *****
DO 5 I-1, ICELLS+1
5 READ(LUN, FORM) (XCT(I, J), J-1, JCELLS+1)
DO 15 I-1, ICELLS+1
15 READ(LUN, FORM) (YCT(I, J), J-1, JCELLS+1)

***** SEQ - -YX *****
DO 6 I-1, ICELLS+1
6 READ(LUN, FORM) (XCT(I, J), J-1, JCELLS+1, 1, -1)
DO 16 I-1, ICELLS+1
16 READ(LUN, FORM) (YCT(I, J), J-1, JCELLS+1, 1, -1)

***** SEQ - Y-X *****
DO 7 I-ICELLS+1, 1, -1
7 READ(LUN, FORM) (XCT(I, J), J-1, JCELLS+1)
DO 17 I-ICELLS+1, 1, -1
17 READ(LUN, FORM) (YCT(I, J), J-1, JCELLS+1)
***** SEQ - -Y-X *****
DO 8 I-ICELLS+1, 1, -1
8 READ(LUN, FORM) (XCT(I, J), J-1, JCELLS+1, 1, -1)
DO 18 I-ICELLS+1, 1, -1
18 READ(LUN, FORM) (YCT(I, J), J-1, JCELLS+1, 1, -1)
```

CMS Data Specification:

XSTRETCH and YSTRETCH Records: (C-opt)

Purpose: Specify the data to create grid coordinates in a stretched rectilinear cartesian coordinate system.

Field	Variable	Type Char *8	Status (Req)	Default	Permitted		Usage
					Data		
1	CARDID				XSTRETCH		Record identifier. (for X-coordinates)
					YSTRETCH		(for Y-coordinates)
2	ALPHAB	Integer	(Req)		I*		Alpha at beginning of grid subregion.
3	ALPHAE	Integer	(Req)		I*		Alpha at end of grid subregion.
4-5	A	Real	(Req)		R*		Stretching coefficients used to determine the X- and Y- coordinates in this grid subregion employing a power function of the form: X (or) Y = A + B * (ALPHA ** C)
6-7	B	Real	(Req)		R*		
8-9	C	Real	(Req)		R*		

Notes:

- (1) Use one record per grid subregion (must be sequential...ie..Region1, Region2....etc)
- (2) These records may be generated by MAPIT in the CMSGRID package.
- (3) These records are required if RSTRETCH was specified for CRTYPE on GRIDSPEC record.
- (4) A, B, and C use a special format: each should be G16.9 (occupies two fields)

CMS Data Specification: BATHSPEC Record: (Req)
 Purpose: Specify general characteristics of the bathymetry/topography data.

Field	Variable	Type	Status	Default	Permitted Data	Usage
1	CARDID	Char #8	(Req)		BATHSPEC	Record identifier.
2	BUNITS	Char #8	(Opt)	FEET	FEET METERS FATHOMS	Declares the units for the following bathymetry/topography data.
3	WDATUM	Real	(Opt)	0.	R*	Positive values of bathymetry (depths) are added to this datum value (in BUNITS)
4	LDATUM	Real	(Opt)	0.	R*	Negative values of topography are added to this datum (in BUNITS).
5	DLIMIT	Real	(Opt)	6000. ft	R*	A limiting water depth (deeper values are set to this value in BUNITS).
6	BSEQ	Char #8	(Opt)	XY	XY -XY X-Y -X-Y YX -YX Y-X -Y-X	The 2-d array of bathymetry/topography which follows this record, is read in a sequence specified by this mnemonic code (see notes for the conventions represented by these mnemonics).
7-8	BFORM	Char #16	(Opt)	(8G10.3)	A*	Format used to read the following 2-d array of bathymetry/topography values.
9-10	BNAME	Char #16	(Opt)		A*	Name of bathymetry/topography set.

(Continued)

(Concluded)

Notes:

- (1) The actual 2-d array of bathymetry/topography data follows this record.
- (2) Conventions for 2-d array read sequence mnemonics:

```
***** SEQ = XY *****
DO 1 J=1,JCELLS
  1 READ(LUN,FORM) (VAR(I,J),I=1,ICELLS)
***** SEQ = -XY *****
DO 2 J=1,JCELLS
  2 READ(LUN,FORM) (VAR(I,J),I=ICELLS,1,-1)
***** SEQ = X-Y *****
DO 3 J=JCELLS,1,-1
  3 READ(LUN,FORM) (VAR(I,J),I=1,ICELLS)
***** SEQ = -X-Y *****
DO 4 J=JCELLS,1,-1
  4 READ(LUN,FORM) (VAR(I,J),I=ICELLS,1,-1)
***** SEQ = YX *****
DO 5 I=1,ICELLS
  5 READ(LUN,FORM) (VAR(I,J),J=1,JCELLS)
***** SEQ = -YX *****
DO 6 I=1,ICELLS
  6 READ(LUN,FORM) (VAR(I,J),J=JCELLS,1,-1)
***** SEQ = Y-X *****
DO 7 I=ICELLS,1,-1
  7 READ(LUN,FORM) (VAR(I,J),J=1,JCELLS)
***** SEQ = -Y-X *****
DO 8 I=ICELLS,1,-1
  8 READ(LUN,FORM) (VAR(I,J),J=JCELLS,1,-1)
```

CMS Data Specification: CHNGBATH Record: (Opt)
 Purpose: Specify changes to the bathymetry data.

Field	Variable	Type	Status	Default	Permitted	Usage
		Char #8	(Req)		Data	Record Identifier.
					CHNGBATH	
1	CARDID					
2	BATH	Real	(Req)		R*	New bathymetry/topography value (in BUNITS ... the two datum shift values LDATUM and WDATUM will not be applied to this value).
3	X1INDX	Integer	(Req)		I*	Declares the location of the bathymetry /topography value as a point, line, or a rectangular patch in the grid.
4	Y1INDX	Integer	(Req)		I*	
5	X2INDX	Integer	(Opt)	0	I*	
6	Y2INDX	Integer	(Opt)	0	I*	

Note:

- (1) Use one CHNGBATH record per value (no changes if this record is omitted).
- (2) All CHNGBATH records must follow 2-dimensional bathymetry array.

CMS Data Specification: XBARRIER and YBARRIER Records: (Opt) .
 Purpose: Specify the location and characteristics of a subgrid-scale barrier.

Field	Variable	Type	Status	Default	Permitted Data	Usage
1	CARDID	Char *8	(Req)		XBARRIER	Record identifier. (Aligned perpendicular to X- axis)
					YBARRIER	Record identifier. (Aligned perpendicular to Y- axis)
2	BRPOS1	Integer	(Req)		+I*	Cell indices declaring the barrier location within the grid; Barrier extends from (and includes) cells BRPOS2 to BRPOS3 along the face of cell BRPOS1.
3	BRPOS2	Integer	(Req)		+I*	
4	BRPOS3	Integer	(Req)		+I*	
5-7	BARNAM	Char *24	(Opt)		A*	Barrier name.

Note:
 (1) Use one XBARRIER or YBARRIER record per barrier.

CMS Data Specification: FRICTION Record: (Opt)
 Purpose: Specify the character of bottom friction.

Field	Variable	Type	Status	Default	Permitted		Usage
					Char #8	Char #8	
1	CARDID	Char #8	(Req)	CONSTANT	CONSTANT	FRICTION	Friction values constant in time and space (constant C_f); separate values for "land" and "water" areas permitted (see FRLAND and FRWATER below).
4	FRDEF	Char #8	(Req)	CONSTANT	CONSTANT	VARYBATH	Friction values vary with bathymetry (as defined with FRICTABL records following this record).
						TABULAR	Friction values are assigned to each cell and the 2-D array must follow this record).
5	FRLAND	Real	(C-opt)	.048 (SI) .040 (British)	+R*	+R*	Friction value for all "land" areas (used only if CONSTANT specified for FRDEF).
6	FRWATR	Real	(C-opt)	.030 (SI) .025 (British)	+R*	+R*	Friction value for all "water" areas (used only if CONSTANT specified for FRDEF).
7	FDMAX	Real	(Opt)	300 ft 100 m	R*	R*	Maximum water depth (in SUNITS) which will exert a change in variable friction.

(Continued)

(Concluded)

8	FSEQ	Char *8	(Opt)	XY	XY -XY X-Y -X-Y YX -YX Y-X -Y-X	The 2-D array of friction values that follows this record is read in a sequence specified by this mnemonic code (see notes for the conventions represented by these mnemonics).
---	------	---------	-------	----	--	---

9	FFORM	Char *8	(Opt)	(8G10.3) A*		Format used to read the following 2-D array of friction values. friction.
---	-------	---------	-------	-------------	--	--

Notes:

- (1) If this record is omitted, the above default values will be used.
- (2) If VARYBATH is selected for FRDEP, the table of friction values versus the depth follows this record as FRICTABL records.

CMS Data Specification: FRICTABL Record: (C-Opt)

Purpose: Specify an entry in the friction values versus bathymetry table.

Field	Variable	Type	Status	Default	Permitted	
					Data	Usage
1	CARDID	Char *8	(Req)		FRICTABL	Record identifier.
2	FRICT	Real	(Req)		R*	Friction coefficient (C_f) value.
3	FDEPTH	Real	(Req)		R*	Bathymetry value to use for the corresponding friction value (less than or equal to this depth).

Note: Friction values are not interpolated; they are assigned on a "less than or equal" basis governed by the given bathymetry value (in a range down to the next lower valued bathymetry entry); since the first entry (lowest bathymetry value) has no lower limit, all regions with bathymetry values less than this entry will have the friction value entry on the first FRICTABL record.

CMS Data Specification: CHNGFRIC Record: (Opt)

Purpose: Modify the friction values at selected locations.

Field	Variable	Type	Status	Default	Permitted		Usage
					Data	CHNGFRIC	
1	CARDID	Char *8	(Req)				Record identifier.
2	FRICT	Real	(Req)		+R*		New friction coefficient (C_1) value (in FRUNIT).
3	X1INDX	Integer	(Req)		+I*		Declares the location of the new friction values as a point, line, or a rectangular patch of cells in the grid.
4	Y1INDX	Integer	(Req)		+I*		
5	X2INDX	Integer	(Opt)	0	+I*		
6	Y2INDX	Integer	(Opt)	0	+I*		

Notes:

- (1) No changes to friction are made if this record is omitted.
- (2) Use one CHNGFRIC record for each new friction value (or location).

CMS Data Specification: XBOUNDRY and YBOUNDRY Record: (OPT)
 Purpose: Specify location and character of a driving boundary.

Field	Variable	Type	Status	Default	Permitted Data	Usage
1	CARDID	Char #8	(Req)		XBOUNDRY YBOUNDRY	Record identifier. (Boundary perpendicular to X-axis) (Boundary perpendicular to Y-axis)
2	BNDTYP	CHAR #8	(Req)		CONSTELV	All cells of the driving boundary act in unison as a single elevation forcing function.
					INTRPELV	Driving boundary cells vary independently as interpolated from two elevation forcing functions applied at the ends of the boundary segment.
					CONSTDIS	All cells of the driving boundary act in unison as a single discharge forcing function.
					BAROMETR	Driving boundary cells vary independently as determined by the "inverted barometer" effect (from windfield and pressure data).
					UNIFLUX	Boundary is specified as a "uniform flux" condition.
3	BNPOS1	Integer	(Req)		+I*	Cell indices declaring driving boundary location within the grid: Boundary extends from (and includes) cells BNPOS2 to BNPOS3 along cell BNPOS1.
4	BNPOS2	Integer	(Req)		+I*	
5	BNPOS3	Integer	(Req)		+I*	

(Continued)

(Concluded)

6	BNDFN1	Integer	(C-opt)	+I*	Integer index of forcing function (tabular or harmonic constituent) for CONSTELV, INTRPELV or CONSTDIS type boundaries.
7	BNDFN2	Integer	(C-opt)	+I*	Integer index of 2nd forcing function used for interpolation on a INTRPELV type boundary.
8-10	BNDNAM	Char *24	(Opt)	A*	Boundary name.

Notes:

- (1) An XBOUNDRY or YBOUNDRY record is required for each distinct driving boundary.
- (2) For BNDTYP of CONSTELV or CONSTDIS, a function must be provided (the same function may be shared by several driving boundaries).
- (3) For BNDTYP of INTERPELV, 2 functions must be provided (and again may be shared).

CMS Data Specification: FUNCTION Record: (C-opt)

Purpose: Specify index number and character of driving boundary forcing function.

Field	Variable	Type	Status	Default	Permitted Data	Usage
			(Req)		FUNCTION	Record Identifier.
1	CARDID	Char *8				
2	FUNNO	Integer	(Req)		+I*	Index number of Function.
3	FUNTP	Char *8	(Req)		HARMCNST	Elevation forcing function to be generated using harmonic constituents (2 groups of data must follow this record ... CNRECORD and CONSTIT(s)).
					TABELEVS	Elevations are provided in tabular form (2 groups of data must follow this record ... TERECD and TABELV or 1-D array).
					TABFLOWS	Discharges are provided in tabular form (2 groups of data must follow this record ... TFRECORD and TABFLOW or 1-D array).
4	FUNITS	Char *8	(Opt)	FEET	FEET METERS FPS MPS	Declares units for the given elevations or flows (function values).
5	FMULT	Real	(Opt)	1.0	R*	The function values are multiplied by this factor.
6	FDATUM	Real	(Opt)	0.0	R*	The function values are added to this "datum" quantity.

(Continued)

(Concluded)

7	FSHIFT	Real	(Opt)	0.	R*
The function values are shifted in time by this amount (in TUNITS).					
NOTE: + Shift forward in time					
- Shift backward in time					
8	FEATHR	Real	(Opt)	0.	R*
The function is gradually spline fit from initial conditions (usually zero) to the given function value over the FEATHR period (in TUNITS).					

CMS Data Specification: CNRECORD Record: (C-opt)

Purpose: Specify physical coordinates and timing of a constituent forcing function.

Field	Variable	Type Char #8	Status (Req)	Default	Permitted		Usage
					Data	Record identifier	
1	CARDID	Char #8	(Req)		CNRECORD		Record identifier.
2	RLONG	Real	(Opt)	0.	R*		Record longitude (in decimal degrees).
3	RYEAR	Real	(Req)		I*		Year at beginning of record.
4	RMONTH	Real	(Req)		I*		Month at beginning of record.
5	RDAY	Real	(Req)		I*		Day (of month) at beginning of record.
6	RHOUR	Real	(Req)		R*		Hour (of day) at beginning of record.
7-16	RNAME	Char #32	(Opt)		A*		Record name.

Notes:

- (1) This record must follow a FUNCTION record if HARMCNST was specified as FUNTYP.
- (2) This record must be followed by one or more CONSTIT records.

CMS Data Specification:
 Purpose:

CONSTIT Record: (C-opt)
 Specify and quantify a harmonic constituent for a boundary forcing function.

Field	Variable	Type	Status	Default	Permitted Data	Usage
1	CARDID	Char *8	(Req)		CONSTIT	Record identifier.
2	CNAME	Char *8	(Req)		A*	Constituent name (see list of 37 available constituents in Table 4-5)
3	CAMP	Real	(Req)		+R*	Constituent amplitude (in FUNITS).
4	CEPOCH	Real	(Req)		R*	Constituent epoch (decimal degrees).

Notes:
 (1) Use one CONSTIT record for each constituent to be included in the forcing function.

CMS Data Specification: TERECORD and TFRECORD Record: (C-opt)
 Purpose: Specify general information for a tabular elevation (TERECORD)
 or tabular (TFRECORD) boundary forcing function.

Field	Variable	Type	Status	Default	Permitted Data	Usage
1	CARDID	Char *8	(Req)		TERECORD	Record identifier for tabular elevations. Record identifier for tabular flows.
2	RENT	Integer	(C-opt)		+I*	Number of entries in the tabular record.
3	RSTART	Integer	(C-opt)		+I*	Index number of an entry in the tabular record to be used as the start of the record.
4	RRINT	Real	(Req)		+R*	Time interval (in TUNITS) at which entries are recorded (applies to regularly-spaced data to be provided in a 1-d array following this record).
5-6	RFORM	Char *16	(Opt)	(8G10.3)	A*	Tabular data are provided at irregular intervals (times of individual entries will be specified on TABLEV or TABFLOW records following this record). Optional format specifier used for reading tabular data (applies to regularly-spaced data provided in a 1-d array following this record ... does not apply if IRREGINT selected for RPRINT above).
7-10	RNAME	Char *32	(Opt)		A*	Tabular record name.

(Continued)

(Concluded)

Notes:

- (1) This record must follow a FUNCTION record if TABELVS or TABFLOWS specified for FUNTYP.
 - (2) If the tabular data are regularly-spaced (in time), a 1-d array must follow this record.
 - (3) If the tabular data are provided at irregular time intervals, one or more TABELEV or TABFLOW records must follow this record.
-

CMS Data Specification:
Purpose:

TABELEV or TABFLOW Records: (C-Opt)
 Specify the time and value of an entry in an irregularly-spaced tabular elevation or flow forcing function.

Specify the time and value of an entry in an irregularly-spaced tabular elevation or flow forcing function.

<u>Field</u>	<u>Variable</u>	<u>Type</u> Char *8	<u>Status</u> (Req)	<u>Default</u>	<u>Permitted</u> Data	<u>Usage</u>
1	CARDID		(Req)		TABELEV	Record identifier for a tabular elevation entry.
					TABFLOW	Record identifier for a tabular flow entry.
2	FHR	Real	(Req)		R*	Hour of the tabular entry (hours).
3	FMIN	Real	(Req)		R*	Minute of the tabular entry (minutes).
4	FSEC	Real	(Req)		R*	Second of the tabular entry (seconds).
5	FMAG	Real	(Req)		R*	Value of tabular entry at the above time (in FUNITS).

Notes:

(1) Use one TABELEV or TABFLOW record for each entry of the tabular forcing function.

CMS Data Specification: WINDSPEC Record: (Opt)
 Purpose: Specify the character of wind field data.

Field	Variable	Type	Status	Default	Permitted Data	Usage
1	CARDID	Char *8	(Req)		WINDSPEC	Record identifier.
2	WNTRVL	Char *8	(Opt)		UNIFSTRS UNIFSPED SPVRSTRS SPVRSPED TVRUNIST TVRUNISP TSPVRSTR TSPVRSPD	<p>If wind stress is constant with respect to time and space, one TABWINDS record should follow this record.</p> <p>If wind speed is constant with respect to time and space, one TABWINDS record should follow this record.</p> <p>If wind stress varies spatially, this record is followed by one TABWINDS record and wind stress arrays.</p> <p>If wind speed is varies spatially, this record is followed by one TABWINDS record and wind speed arrays.</p> <p>If wind stress varies with respect to time, several TABWINDS records follow this record.</p> <p>If wind speed varies with respect to time, several TABWINDS records follow this record.</p> <p>If wind stress varies with respect to time and space, this record is followed by several TABWINDS records. Each TABWINDS record is followed by wind stress arrays.</p> <p>If wind speed varies with respect to time and space, this record is followed by several TABWINDS records. Each TABWINDS record is followed by wind speed arrays.</p>

(Continued)

(Concluded)

3 WUNITS Char *8 (Opt) FPS Units for wind values.

MPH
FPS
MPS
KNOTS

8-10 WNAME Char *24 (Opt) A* Wind event name.

Note: (1) No winds are applied to the model if this record is omitted.

CMS Data Specification: TABWINDS Record: (C-opt)
 Purpose: Specify wind field data.

Field	Variable	Type	Status	Default	Permitted Data	Usage
1	CARDID	Char *8	(Req)		TABWINDS	Record identifier.
2	IDAY	Integer	(C-opt)		+I*	Day of wind data entry (days).
3	IHOURL	Integer	(C-opt)		+I*	Hour of wind data entry (hours).
4	TAUX	Real	(Req)		R*	X-component of wind stress or speed.
5	TAUY	Real	(Req)		R*	Y-component of wind stress or speed.

CMS Data Specification: WAVESPEC Record: (Opt)
 Purpose: Specify the character of wave-field data.

Field	Variable	Type	Status	Default	Permitted		Usage
					Data	Record identifier	
1	CARDID	Char *8	(Req)		WAVESPEC		Record identifier.
2	WAVMODEL	Char *8	(Req)		RCPWAVE STWAVE		Wave input from RCPWAVE model. Wave input from STWAVE model.
3	IBUILD	Integer	(Opt)	0	+I*		Time interval (in time-steps) over which the wave stress term in built up from zero to the full value.

CMS Data Specification: PRWINDOW Record: (Opt)
 Purpose: Specify location and timing of a print window.

Field	Variable	Type	Status	Default	Permitted	Usage
						Record identifier.
1	CARDID	Char #8	(Req)		PRWINDOW	
2	WXCEL1	Integer	(Opt)	1	+I*	Cell indices declaring the grid subregion or window for printing the selected variables. The window will be bounded by (and include) the region from (WXCEL1,WYCEL1) to (WXCEL2,WYCEL2).
3	WXCEL2	Integer	(Opt)	ICELLS	+I*	
4	WYCEL1	Integer	(Opt)	1	+I*	
5	WYCEL2	Integer	(Opt)	JCELLS	+I*	
6	WPRINT	Integer	(Opt)	1	+I*	Time interval (in timesteps) at which the print window is to be recorded.
7	WPRSTR	Integer	(Opt)	1	+I*	Timestep at which print window is to begin recording.
8	WPREND	Real	(Opt)	TMAX	+R*	Timestep at which print window is to end recording.
9-10	WPRVAR	Char #16	(Opt)	EV	E V W B D F	Water surface elevations. Water velocities (2 components). Wind velocities (2 components). Bathymetry value. Depth of water column. Friction value.

Note: Use 1 PRWINDOW record/window (in space or time).

CMS Data Specification: RECGAGE Record: (Opt)
 Purpose: Specify location and character of a recording gage in the grid.

Field	Variable	Type	Status	Default	Permitted	Data	
1	CARDID	Char #8	(Req)			RECGAGE	Record identifier.
2	IST	Integer	(Req)		+I*		X-index of gage location within grid.
3	JST	Integer	(Req)		+I*		Y-index of gage location within grid.
4-5	STATID	Char #16	(Opt)		A*		Station (or gage) name.

Notes:
 (1) Use 1 RECGAGE record per gage.
 (2) The interval for recording all gage data was specified by NFREQ on the TIMESPEC record.

CMS Data Specification: RECSNAPS Record: (Opt)
 Purpose: Specify snapshot time(s) for recording.

Field	Variable	Type	Status	Default	Permitted Data	Usage
1	CARDID	Char *8	(Req)		RECSNAPS	Record identifier.
2	SNPTYP	Char *8	(Req)		INTERVAL	Snapshot data to be recorded regular time intervals.
3	SXCELL1	Integer	(Opt)	1	+I*	Cell indices declaring the grid subregion or window for printing the selected variables. The window will be bounded by (and include) the region from (SXCELL1,SYCELL1) to (SXCELL2,SYCELL2).
4	SXCELL2	Integer	(Opt)	ICELLS	+I*	
5	SYCELL1	Integer	(Opt)	1	+I*	
6	SYCELL2	Integer	(Opt)	JCELLS	+I*	
7	SNPINT	Integer	(Opt)	1	+I*	Regular time interval (in timesteps) at which snapshot data are to be recorded.
8	SNPSTR	Integer	(Opt)	1	+I*	Timestep at which snapshot recording is to begin.
9	SNPEND	Real	(Opt)	IT2	+I*	Timestep at which snapshot recording is to end.

(Continued)

(Concluded)

----- Alternate form for specific times -----

Field	Variable	Type	Status	Default	Data	Usage
1	CARDID	Char *8	(Req)		RECSNAPS	Record identifier.
2	SNPTYP	Char *8	(Req)		TIMES	Snapshot data to be recorded at specific times (which follow on this record in fields 3-10).
3-10	SNPTIM	Real	(Req)		+R*	Timestep at which a snapshot is to be recorded (1 SNPTIM/field in fields 3-10). Use additional records of this format if more than 8 specific times are required.

Notes: (1) Any number of both types of snapshot records may be specified.

(2) Times specified must be integer multiples of DT

CMS Data Specification: XRECRANG and YRECRANG Records: (Opt)
 Purpose: Specify location and name of a discharge recording range within the grid.

Field	Variable	Type	Status	Default	Permitted	Usage
1	CARDID	Char #8	(Req)		XRECRANG	Record identifier. (Range perpendicular to X-axis)
					YRECRANG	Record identifier. (Range perpendicular to Y-axis)
2	RPOS1	Integer	(Req)		+I*	Cell indices declaring recording range location within the grid; Range extends from (and includes) cells RPOS2 to RPOS3 along the face of cell RPOS1.
3	RPOS2	Integer	(Req)		+I*	
4	RPOS3	Integer	(Req)		+I*	
5-10	RRNAME	Char #45	(Opt)		A*	Range name.

Notes:
 (1) Use 1 XRECRANG or YRECRANG record per range.
 (2) The time interval for recording range data was specified by NFREQ on the TIMESPEC record.

APPENDIX 14-C: INPUT DATA SET FOR THE INDIAN RIVER INLET EXAMPLE

GFNSPECS	INDIAN RIVER INLET				ENGLISH
GRIDSPECCURVILIN	ENGLISH	84	84	66666.6 66666.6	1.0
GRIDCORN	XY (F12.5,4F16.5)				
3333.33301	5000.00000	6666.66699	8333.33301	10000.0000	
11666.6699	13333.3301	15000.0000	16666.6699	18333.3301	
20000.0000	21666.6699	23333.3301	25000.0000	26666.6699	
28333.3301	30000.0000	31666.6699	33333.3281	35000.0000	
36666.6602	38106.6719	39183.3281	40000.0000	40666.6602	
41250.0000	41770.0000	42226.6719	42636.6719	43003.3281	
43333.3281	43633.3281	43906.6602	44160.0000	44396.6719	
44613.3281	44813.3281	45000.0000	45186.6602	45390.0000	
45610.0000	45846.6602	46100.0000	46373.3281	46666.6602	

TIMESPEC	20.	SECONDS	1	11340	90									
ADDTERMS	YES	NO	0.0	0.00009										
YBOUNDRYCONSTELV	1	70	83	1										
XBOUNDRYCONSTELV	84	1	84	1										
YBOUNDRYCONSTELV	84	68	83	1										
FUNCTION	1	TABELEV	FEET	0.5										
TERECORD	127	1	1800.	(15F5.2)										
1.80	1.90	2.00	2.11	2.42	2.42	2.39	2.23	1.90	1.54	1.12	0.72	0.13	-.56	-1.15
-1.61	-2.07	-2.30	-2.42	-2.39	-2.29	-1.97	-1.74	-1.41	-0.98	-0.49	-0.10	0.30	0.59	0.69
0.76	0.66	0.06	0.36	0.13	-.26	-.62	-1.18	-1.61	-2.07	-2.36	-2.49	-2.52	-2.26	-2.00
-1.61	-1.18	-.69	-.10	0.56	1.12	1.77	2.20	2.62	2.78	2.88	2.79	2.49	2.20	1.77
1.28	0.66	0.16	-.46	-1.12	-1.67	-2.07	-2.26	-2.29	-2.19	-1.90	-1.64	-1.32	-.89	-.26
0.16	0.59	0.98	1.12	1.25	1.25	1.18	0.95	0.66	0.46	0.00	-.43	-1.05	-1.54	-1.94
-2.19	-2.26	-2.32	-2.10	-1.74	-1.35	-.85	-.39	0.23	0.85	1.51	2.03	2.55	2.88	3.05
2.92	2.82	2.62	2.30	1.84	1.35	0.62	-.16	-.89	-1.44	-1.94	-2.16	-2.19	-2.23	-2.00
-1.77	-1.38	-.98	-.69	-.10	0.26	0.76	0.00	0.00						
WINDSPECTVRUNISP		FPS												
TABWINDS	0	0	-2.201	11.077										
TABWINDS	0	1	-2.096	12.884										
TABWINDS	0	2	-0.763	13.472										
TABWINDS	0	3	2.750	13.210										
TABWINDS	0	4	5.101	8.570										
TABWINDS	0	5	3.952	7.200										
TABWINDS	0	6	5.934	5.022										
TABWINDS	0	7	5.988	3.088										
TABWINDS	0	8	7.783	2.120										
TABWINDS	0	9	6.150	0.348										
TABWINDS	0	10	4.494	-0.692										
TABWINDS	0	11	6.008	-1.361										
TABWINDS	0	12	4.059	-0.625										
TABWINDS	0	13	3.290	-0.745										
TABWINDS	0	14	3.857	-2.117										

TABWINDS	0	15	5.194	-2.396
TABWINDS	0	16	2.875	2.031
TABWINDS	0	17	-3.090	0.930
TABWINDS	0	18	-6.266	2.501
TABWINDS	0	19	-5.526	5.876
TABWINDS	0	20	-6.123	7.497
TABWINDS	0	21	-10.286	3.899
TABWINDS	0	22	-8.928	6.916
TABWINDS	0	23	-5.832	4.200
TABWINDS	1	0	-3.526	4.317
TABWINDS	1	1	10.423	1.696
TABWINDS	1	2	11.877	0.257
TABWINDS	1	3	10.183	3.755
TABWINDS	1	4	6.334	2.720
TABWINDS	1	5	4.485	1.860
TABWINDS	1	6	4.708	1.643
TABWINDS	1	7	7.489	3.372
TABWINDS	1	8	6.713	-0.677
TABWINDS	1	9	4.413	1.987
TABWINDS	1	10	0.535	3.924
TABWINDS	1	11	7.816	3.357
TABWINDS	1	12	5.941	4.044
TABWINDS	1	13	6.841	3.371
TABWINDS	1	14	7.104	2.341
TABWINDS	1	15	8.083	1.460
TABWINDS	1	16	7.517	-3.309
TABWINDS	1	17	3.155	-6.129
TABWINDS	1	18	-6.163	-1.913
TABWINDS	1	19	-7.929	-3.082
TABWINDS	1	20	-9.665	-2.999
TABWINDS	1	21	-7.295	1.652
TABWINDS	1	22	-7.072	3.881
TABWINDS	1	23	-6.039	1.819
TABWINDS	2	0	-6.660	4.286
TABWINDS	2	1	-3.646	8.490
TABWINDS	2	2	-2.020	7.961
TABWINDS	2	3	3.413	4.406
TABWINDS	2	4	8.600	1.866
TABWINDS	2	5	10.069	-1.016
TABWINDS	2	6	4.721	-5.990
TABWINDS	2	7	5.169	-4.780
TABWINDS	2	8	-0.551	-11.427
TABWINDS	2	9	-3.668	-11.454
TABWINDS	2	10	-8.492	-13.718
TABWINDS	2	11	-5.476	-9.200
TABWINDS	2	12	-2.071	-7.340
TABWINDS	2	13	-3.808	-8.250
TABWINDS	2	14	-8.427	-9.776
TABWINDS	2	15	-7.454	-9.624
BATHSPEC	FEET	0.0	0.0	
0.0	0.0	0.0	9.5	9.4
8.5	8.5	8.5	8.5	8.5
7.5	7.4	7.4	7.4	7.4
7.8	7.7	7.7	7.7	7.7
7.2	7.2	7.2	6.7	6.7

YX(10F8.1)

9.6	10.1	7.4	10.0	8.5
8.4	8.4	7.9	7.8	7.5
7.9	7.8	7.8	7.8	7.8
7.7	7.6	7.6	7.6	7.6
7.2	7.2	7.1	7.1	7.1

0.020	0.020	0.020	0.020	0.020	0.020	0.020	0.020	0.020	0.020
0.020	0.020	0.020	0.020	0.020	0.020	0.020	0.020	0.020	0.020
0.020	0.020	0.020	0.020	0.020	0.020	0.020	0.020	0.020	0.020
0.020	0.020	0.020	0.020	0.020	0.020	0.020	0.020	0.020	0.020
0.020	0.020	0.020	0.020	0.020	0.020	0.020	0.020	0.020	0.020
0.020	0.020	0.020	0.020	0.020	0.020	0.020	0.020	0.020	0.020
0.020	0.020	0.020	0.020	0.020	0.020	0.020	0.020	0.020	0.020
0.020	0.020	0.020	0.020	0.020	0.020	0.020	0.020	0.020	0.020
0.020	0.020	0.020	0.020	0.020	0.020	0.020	0.020	0.020	0.020
0.020	0.020	0.020	0.020	0.020	0.020	0.020	0.020	0.020	0.020
0.020	0.020	0.020	0.020	0.020	0.020	0.020	0.020	0.020	0.020
RECGAGE	70	27							
RECGAGE	70	28							
RECGAGE	70	29							
RECGAGE	36	49							
RECGAGE	44	48							
RECGAGE	42	48							
RECGAGE	38	49							
RECGAGE	6	5							
RECGAGE	16	45							
RECGAGE	36	57							
RECGAGE	58	81							
RECGAGE	63	32							
RECGAGE	43	48							
RECGAGE	37	50							
RECGAGE	35	50							
RECGAGE	69	27							
RECGAGE	69	28							
RECGAGE	69	29							
RECSNAPSINTERVAL						720	7920	9360	
RECRANG XRECRANG		69	26	29					
RECRANG XRECRANG		45	48	53					