

AD-A283 988



Field Screening Method for TNT and RDX in Groundwater

Thomas F. Jenkins, Phillip G. Thorne and Marianne E. Walsh

May 1994

DTIC
ELECTE
SEP. 02 1994
S B D

DISTRIBUTION STATEMENT A
Approved for public release
Distribution Unlimited

DTIC QUALITY INSPECTED 1

Abstract

Two field screening methods were developed to determine TNT and RDX in groundwater. Both methods rely on solid phase extraction to remove analytes from the water and effect preconcentration. For the first method, a 500-mL water sample is passed through a 3-mL solid phase extraction cartridge packed with HayeSep R. TNT and RDX are then eluted from the cartridge with acetone and the extract divided into two portions. One portion of the extract is reacted with acetic acid and zinc to convert RDX to nitrous acid. The nitrous acid is converted to an azo dye with a Griess reagent and the concentration estimated by the absorbance at 507 nm (Griess method). The second portion of the extract is reacted with a pellet of KOH and about 0.3 mg of sodium sulfite. The concentration of TNT is estimated from the absorbance at 540 nm of the Janowsky anion (Janowsky method). Using these methods, and visual detection of the colored solutions produced, samples containing $5 \mu\text{g L}^{-1}$ of either TNT or RDX can be reliably distinguished from uncontaminated water. In the second method, a 2-L water sample is passed through a stack of two 47-mm Empore SDVB disks to preconcentrate TNT and RDX. The top disk is removed, the bottom disk eluted with 5 mL of acetone and the extracted RDX determined using the Griess method described above. The top disk is then replaced and eluted with 20 mL of acetone and the extracted TNT determined by the Janowsky method described above. Using these methods and visual detection of the colored solutions, water samples containing $2 \mu\text{g L}^{-1}$ of either TNT or RDX can be reliably distinguished from uncontaminated water. For quantitative analysis, use of these methods and absorbance measurements with a spectrophotometer resulted in Method Detection Limits (MDL) of $0.9 \mu\text{g L}^{-1}$ for TNT, but a higher value of $3.8 \mu\text{g L}^{-1}$ for RDX. The higher MDL for RDX is caused by poor reproducibility in RDX recovery from the bottom membrane.

For conversion of SI metric units to U.S./British customary units of measurement consult *Standard Practice for Use of the International System of Units (SI)*, ASTM Standard E380-89a, published by the American Society for Testing and Materials, 1916 Race St., Philadelphia, Pa. 19103.

This report is printed on paper that contains a minimum of 50% recycled material.

Special Report 94-14



**US Army Corps
of Engineers**

Cold Regions Research &
Engineering Laboratory

Field Screening Method for TNT and RDX in Groundwater

Thomas F. Jenkins, Phillip G. Thorne and Marianne E. Walsh

May 1994

199 94-28483



Prepared for
U.S. ARMY ENVIRONMENTAL CENTER
SFIM-AEC-TS-CR-94034

Approved for public release; distribution is unlimited.

94 9-01 004

PREFACE

This report was prepared by Dr. Thomas S. Jenkins, Research Chemist, and Philip G. Thorne, Physical Sciences Technician, Biological Sciences Branch, Research Division, and Marianne E. Walsh, Research Chemical Engineer, Applied Engineering Branch, Experimental Engineering Division, U.S. Army Cold Regions Research and Engineering Laboratory. Funding was provided by the U.S. Army Environmental Center (formerly the U.S. Army Toxic and Hazardous Materials Agency), Aberdeen Proving Ground, Maryland, Martin H. Stutz, Project Monitor.

The authors gratefully acknowledge Dr. C.L. Grant, Professor Emeritus, University of New Hampshire, and Louise Parker, CRREL, for their technical reviews of this manuscript. Susan Golden, formerly of Science and Technology Corporation, and Brande Roemholt and Elizabeth Nadeau, CRREL, are acknowledged for conducting several of the experiments described in this report. Martin H. Stutz of the U.S. Army Environmental Center is acknowledged for several useful suggestions.

This publication reflects the personal views of the authors and does not suggest or reflect the policy, practices, programs, or doctrine of the U.S. Army or Government of the United States. The contents of this report are not to be used for advertising or promotional purposes. Citation of brand names does not constitute an official endorsement or approval of the use of such commercial products.

CONTENTS

Preface ii
 Introduction 1
 Analytical requirements and objective 2
 Materials and methods 2
 Cartridges 2
 Membranes 2
 Test solutions 3
 Sample preparation 3
 Color-development-cartridge method 3
 Absorbance measurements 4
 RP-HPLC analysis 4
 Results 4
 Cartridge-based method 4
 Membrane-based method 5
 Recommended method 10
 Conclusions 10
 Literature cited 11
 Abstract 13

ILLUSTRATIONS

Figure
 1. Device used for cartridge solid phase extraction 3
 2. Device used for membrane solid phase extraction 3
 3. Breakthrough curves for RDX using cartridge solid phase extraction with
 HayeSep R 4
 4. Breakthrough curves for RDX using solid phase extraction with SDVB
 Empore extraction membrane 5
 5. Membrane stack used for membrane solid phase extraction 6

TABLES

Table
 1. Proposed water quality criteria for TNT and RDX 2
 2. Results from MDL test for reagent grade water samples 9

Accession For	
NTIS GRA&I	<input checked="" type="checkbox"/>
DTIC TAB	<input type="checkbox"/>
Unannounced	<input type="checkbox"/>
Justification	
By _____	
Distribution/Avail. _____	
Availability Codes	
Dist	Avail and/or Special
A-1	

Field Screening Method for TNT and RDX in Groundwater

THOMAS F. JENKINS, PHILIP G. THORNE AND MARIANNE E. WALSH

INTRODUCTION

Over the last 50 years, a serious environmental problem has developed at many U.S. Army installations: the contamination of soil with residues of secondary explosives from waste discharges from munitions manufacture and the destruction of out-of-date or off-specification material. The most common residues contain 2,4,6-trinitrotoluene (TNT), hexahydro-1,3,5-trinitro-1,3,5-triazine (RDX), and associated impurities and environmental transformation products (Walsh et al. 1993). Unlike many other pollutants, TNT and RDX can often migrate to pollute the groundwater (Pugh 1982, Spaulding and Fulton 1988). To eliminate this pollution, contaminated soils must first be located and characterized. Until recently, this was done exclusively by sending soil samples to off-site laboratories for analysis. While the quality of these data was generally acceptable, it often took weeks or months to receive them, resulting in long project delays. In addition, most of the soils tested blank, wasting Army resources and reducing accurate delineation of the boundaries of contaminated soil. Field methods have been developed at CRREL to rapidly screen soils for the presence of TNT (Jenkins 1990), RDX (Walsh and Jenkins 1991) and 2,4-dinitrotoluene (Jenkins and Walsh 1991). These methods are now in common use and the TNT method has been given work group approval by the EPA Office of Solid Waste as Draft SW846 Method 8515.

Recently, we have had a number of inquiries about field screening methods for explosives in water. The applications appear to be for rapid assessment of potentially contaminated ground-

water and for monitoring of aqueous waste streams after some form of treatment. Several field screening techniques for TNT and RDX in water have been developed. Heller et al. (1982) developed an ion exchange tube that consists of two sections. The first contains a basic oxide to convert TNT to the Meisenheimer anion, which migrates to the second section of the tube where an alkyl quaternary ammonium chloride ion exchange resin retains these anions. This results in a stained region in which the concentration of TNT is proportional to stain length. These tubes are available commercially from Supelco (Bellefonte, Pennsylvania). CRREL evaluated this approach (Jenkins and Schumacher 1990) and concluded that it quite effectively detects TNT at concentrations as low as 40 $\mu\text{g L}^{-1}$, but that accurate quantitation is not possible.

Stevanovic and Mitrovic (1990) developed another method that could be adapted to field use (also discussed in Yinon and Zitrin [1993] p. 233). In this procedure, a 50-mL sample is passed through a porous disk coated with a thin film of silica gel. TNT and RDX are adsorbed onto the surface. The disk is then dried and sprayed with color forming solutions (o-toluidine for TNT and a Griess reagent for RDX). Quantitation is made by measuring diffusely reflected light from the colored surface. The authors estimate detection limits of about 200 $\mu\text{g L}^{-1}$ for TNT and RDX.

A method based on fiber optics for determining TNT in water was developed by Seitz and co-workers (Zhang et al. 1989, Zhang and Seitz 1989) using the reaction of TNT with an amine-loaded PVC (poly(vinyl)chloride) membrane to form a colored product. They used the degree of color

formation, as measured by single fiber optics, to estimate TNT concentration, with a detection limit of about 100 $\mu\text{g L}^{-1}$.

Another approach to the measurement of TNT and RDX was reported by Jian and Seitz (1990). In this method, TNT and RDX are absorbed into a cellulose triacetate membrane containing a fluorophore (pyrenebutyric acid) and their concentration is estimated by fluorescence quenching by the nitro groups on TNT and RDX. Jian and Seitz estimated detection limits for TNT and RDX of 2 and 10 mg L^{-1} respectively.

Simple photometric methods for TNT and RDX have also been developed by Haas and Stork (1989) and Haas et al. (1990), respectively, that could be modified for use in field screening of water samples. To use these methods, a 500-mL water sample is evaporated to dryness at 60°C under vacuum. For RDX, the residue is dissolved in 2 mL of a solution of 1% diphenylamine in 88% sulfuric acid. After the solution reacts for 5 minutes at 50°C, its absorbance is measured at 596 nm. A detection limit of 5 $\mu\text{g L}^{-1}$ is estimated by the authors.

An enzyme immunoassay (EIA) for TNT residues on human hands has been described recently by Fetterolf et al. (1991). Keuchel et al. (1992a,b) describe the development of an EIA method for TNT in water, and test kits for soil and water are available commercially from D TECH Environmental Detection Systems (Hutter et al. 1993) and as prototypes from Millipore Corporation.* These assays use the specific recognition and binding of TNT to proprietary antibodies. TNT in the sample displaces TNT that has been labeled with a color-producing enzyme. Color development is inversely proportional to sample TNT concentration and can be visually compared to a color chart or read electronically. Detection limits are reported to be 5.0 $\mu\text{g L}^{-1}$ for the D TECH kit and 0.5 $\mu\text{g L}^{-1}$ for the Millipore EnviroGard kit. An RDX kit will soon be available from D TECH† with detection limits of 5.0 $\mu\text{g L}^{-1}$.

ANALYTICAL REQUIREMENTS AND OBJECTIVE

In this report, we will evaluate the colorimetric procedure developed at CRREL for field screening of soils to see if it is adaptable to water. While there

* Personal communication with B. Ferguson, ImmunoSystems, Inc., Scarborough, Maine, 1993.

† Personal communication with G.B. Teaney, Strategic Diagnostics, Inc., Newark, Delaware, 1993.

Table 1. Proposed water quality criteria for TNT and RDX (EPA 1988, 1989).

Compound	Health advisory value (lifetime) ($\mu\text{g/L}$)	Cancer model (10 ⁻⁶ risk) ($\mu\text{g/L}$)
TNT	2.0	1.0
RDX	2.0	0.3

are at present no drinking water limits, the EPA has issued health advisories for TNT and RDX (EPA 1989, 1988). Proposed criteria for TNT and RDX are given in Table 1. Both the lifetime health values and the cancer risk values are much lower than can be obtained using any of the methods described above, except for the EnviroGard TNT kit, which is not yet available.

To use the CRREL method, TNT and RDX must be removed from the water matrix and dissolved in acetone. A significant preconcentration must also be achieved since the required detection limits in water are in the low microgram-per-liter or part-per-billion range, whereas the requirements in soil were in the microgram-per-gram or parts-per-million range. So, solid phase extraction was tested to determine its ability to provide the required preconcentration, and then the Janowsky and Griess reactions were used for TNT and RDX, respectively.

MATERIALS AND METHODS

Cartridges

We obtained solid phase extraction tubes (HayeSep R) from Supelco as a special order. Each 3-mL polypropylene tube contained 0.60 g of packing between two polyethylene frits (20- μm pore size). The HayeSep R resin is composed of divinylbenzene (85%) and n-vinyl-2-pyrrolidone (15%) and was 80/100 mesh.

Membranes

Empore extraction membranes (3M) were obtained from Varian. One set of membranes was composed of spherical poly(styrene-divinylbenzene) copolymer (SDVB) particles (particle size 8- μm diameter, pore size 80 Å) in a PTFE matrix (90 \pm 2% adsorbent particle, 10 \pm 2% PTFE). Membrane thickness was 500 μm , in both 47- and 90-mm diameters. According to the manufacturer, the membranes permit flow rates of 5–15 $\text{mL min}^{-1} \text{cm}^{-2}$.

The other set of membranes was composed of irregular C18 (octadecyl) particles (particle size 8-

μm , bonded silica based, pore size 60 Å) in a PTFE matrix. Permissible flow rates are 1–2 mL min^{-1} cm^{-2} . Only the 47-mm-diameter membranes were tested.

Test solutions

All aqueous test solutions were prepared from stock standards obtained by dissolving solid TNT and RDX in water without added organic solvents (Grant et al. 1993).

Sample preparation

Using cartridges

For the field method, each extraction cartridge was placed in the hole of a rubber stopper, and the stopper placed in the neck of a 1-L vacuum flask (Fig. 1). The barrel of a 50-mL disposable syringe was fitted to the top of the solid phase extraction cartridge to serve as a reservoir for the water sample. The barrel reservoir was filled with water, and we pulled a slight vacuum on the flask using a manual vacuum pump, such that the water passed through the cartridge at about 10 mL min^{-1} . The reservoir was refilled periodically to keep the extraction cartridge from drying out until the entire sample had been extracted. Following the sample, a 10-mL aliquot of distilled water was pulled through the cartridge to remove inorganic ions. To elute the analytes, the cartridge and syringe barrel were removed from the rubber stopper, a 10-mL

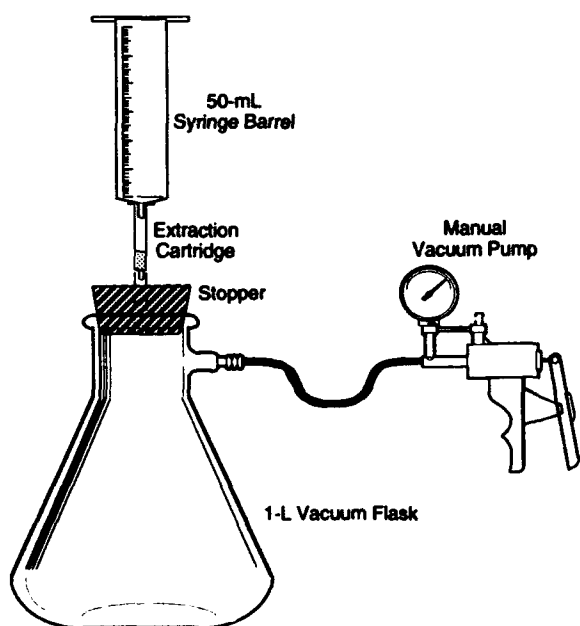

Figure 1. Device used for cartridge solid phase extraction.

aliquot of acetone was added to the syringe barrel, and a plunger was used to force the acetone through the cartridge at 5 mL min^{-1} . The acetone was collected in a 10-mL graduated cylinder. Generally, about 9 mL of acetone was recovered; the volume was brought to 10 mL using acetone.

Using membranes

Membranes were centered on the filtration apparatus (Fig. 2) and cleaned by soaking in acetone for 3 minutes. Vacuum was turned on and before all of the acetone was pulled through, 10 mL of distilled water was added. Sample was then added such that the membrane was not allowed to dry and the reservoir was continuously refilled until all the sample was extracted. The membrane was then dried by maintaining vacuum for 10 minutes. Retained analytes were eluted by adding a small volume of acetone to the filter funnel, allowing the acetone to soak into the membrane for about 3 minutes, and turning on the vacuum, thereby pulling the acetone through the membrane into a test tube placed in the receiver (Fig. 2). The amounts of water extracted, the volume of acetone used and the extraction times observed will be described for each individual experiment.

Color-development-cartridge method

The 10 mL of acetone from each cartridge was split into two 5-mL aliquots in individual scintillation vials. To test for TNT, a pellet of KOH and 0.1–0.5 g of Na_2SO_3 was added to one vial, and the vial was shaken for 3 minutes. The sample was filtered

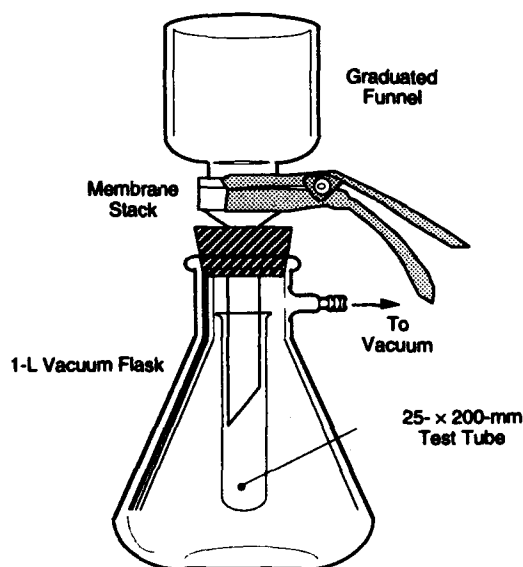

Figure 2. Device used for membrane solid phase extraction.

through a 0.5- μm Millex SR filter unit into a clean scintillation vial and the color of the filtrate noted. Red is a positive test for TNT. Other nitroaromatics are also detected and give various colors: TNB (red), DNB (purple), 2,4-DNT (blue), 2,6-DNT (purple) and tetryl (orange). To test for RDX, 0.5 mL of glacial acetic acid was added to the other 5-mL aliquot of acetone and mixed with 0.3 g of zinc dust. The mixture was rapidly filtered into 20 mL of distilled water and the contents of a Hach NitrVer3 powder pillow added. The sample was shaken briefly and allowed to stand 10 minutes. Development of pink is a positive test for RDX. Other nitramines (such as HMX) and nitrate esters (such as nitroglycerine and PETN) also give a pink color with this procedure. Slight modifications were used for color development for extracts from the membranes and these changes will be discussed later.

Absorbance measurements

Absorbance measurements were made on either a Hach DR/2000 or Hach DR2 spectrophotometer operating on battery power. TNT measurements were made at 540 nm. RDX measurements were made at 507 nm.

RP-HPLC analysis

Water samples and the aqueous effluent from the solid phase extraction cartridges or membranes were analyzed on a 25-cm \times 4.6-mm (5- μm) LC-18 (Supelco) column (EPA 1992). A mobile phase composed of 1:1 (v/v) methanol-water was used at a flow rate of 1.5 mL min^{-1} . A 100- μL aliquot of sample was injected using a sample loop injector and a 254-nm UV detector was used for peak quantitation.

RESULTS

Cartridge-based method

Solid phase extraction and analyte breakthrough—initial studies

On the basis of the work of Valis et al. (1989) and Bicking (1987), we chose to evaluate the use of resin SPE to preconcentrate RDX and TNT from water. Both Valis et al. and Bicking reported excellent analyte recovery using HayeSep R, a commercial cross-linked divinylbenzene-polyvinylpyrrolidone polymer.

To determine how much water could be passed through the resin before analyte breakthrough, aqueous solutions of RDX (148 $\mu\text{g L}^{-1}$) and TNT (42 $\mu\text{g L}^{-1}$) were prepared from aqueous stock solutions (Grant et al. 1993). Two liters of solution was passed through a cartridge at about 10 mL min^{-1} and collected in 100-mL aliquots for determination of RDX and TNT by HPLC. RDX was detected after 400 mL had passed through the cartridge; after 2000 mL, the concentration found in the outflow solution was approximately 26% of the feed solution (Fig. 3). No TNT was detected in the effluent.

To increase the RDX partitioning toward the resin from the water phase, sodium chloride (360 g) was added to another 2-L aqueous solution of RDX and TNT. After 2000 mL, the RDX concentration found in the outflow solution was only 8% of the feed solution (Fig. 3).

Detection capability of cartridge field screening method

On the basis of favorable retention of RDX and TNT by the HayeSep R resin, we tested cartridge solid phase extraction as a practical preconcentration step in a field screening method. To keep

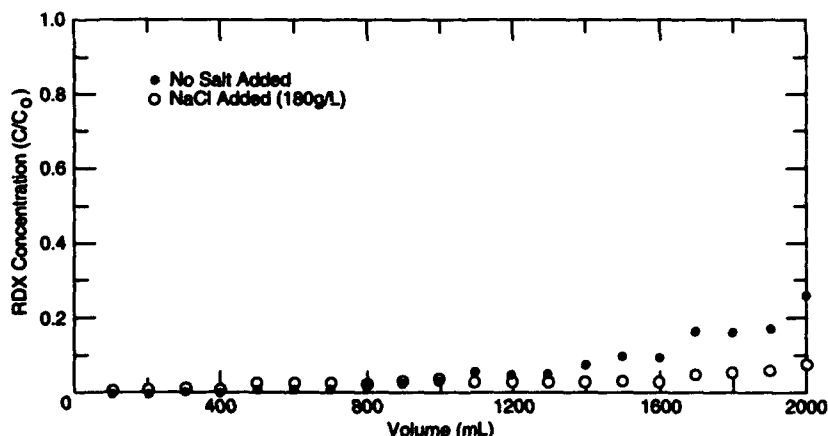

Figure 3. Breakthrough curves for RDX using cartridge solid phase extraction with HayeSep R.

the time required for extraction to about an hour, and because the extraction is most efficient at slow flow rates (less than 10 mL min^{-1}), we chose to extract a 500-mL water sample without added salt. A low-concentration ($5\text{-}\mu\text{g L}^{-1}$) aqueous solution of TNT and RDX was prepared, and four 500-mL replicate subsamples were extracted. Four blank water samples were also extracted. Each extraction cartridge was eluted with 10 mL of acetone, and the acetone split into two aliquots, one for the TNT test and one for the RDX test. Following color development, we asked six people to distinguish the positive samples from the blank samples. Sufficient color had formed such that each examiner correctly identified all blank and positive samples for both TNT and RDX.

Field testing of cartridge method

The field screening procedure was tested at Eagle River Flats, Alaska. Thirty-three 1-L surface water samples were collected and a 500-mL aliquot of each was tested in the field. Neither TNT nor RDX was detected by the field screening procedure. The remaining portion of each water sample was shipped to CRREL for analysis by the standard laboratory HPLC procedure. Again, neither TNT nor RDX was detected. Thus, there were no false negatives for the samples from Eagle River Flats.

The field testing of this method revealed a major problem. Samples that contained suspended material plugged the cartridge and reduced the volume that could be extracted. This problem was minimized by letting the suspended material settle out overnight prior to extracting the sample, but this increased the analysis time of the method and may not always be an acceptable option.

Membrane-based method

Extraction with membranes

A new approach to solid phase extraction was introduced in 1990 (Hagen et al. 1990), using porous membranes that are embedded with adsorptive particles. The main advantage of these membranes is that high flow rates (100 mL min^{-1}) may be used without compromising extraction efficiency. Thus, the length of time required for extraction may be reduced by an order of magnitude. Additionally, wide-diameter membranes (90 mm) that are less susceptible to clogging than the standard 47-mm diameter were marketed in 1992.

We conducted an initial test using 47-mm styrene divinylbenzene (SDVB) and C-18 membranes and aliquots of an aqueous solution containing approximately $50 \mu\text{g L}^{-1}$ each of RDX and TNT. To determine the breakthrough volume of each analyte on each type of membrane, a 10-L sample was passed through the membrane and aliquots of the effluent were collected after each 125 mL for the first 500 mL, every 250 mL up to 2 L, then every 1 L up to 10 L, and the water analyzed for TNT and RDX by HPLC.

In the effluent from the SDVB membranes, RDX was detected after 375 mL, and the effluent concentration was equal to the inflow concentration after 1 L (Fig. 4). In contrast, TNT was well retained; it was not detected in the effluent even after 10 L had passed through the membrane. The C-18 membrane did not retain RDX well at all (Fig. 4) and the retention of TNT was also poor (breakthrough volume less than 500 mL).

To further increase the retention of RDX on the 47-mm SDVB membrane, we added sodium chloride (180 g L^{-1}) to the aqueous analyte solution and

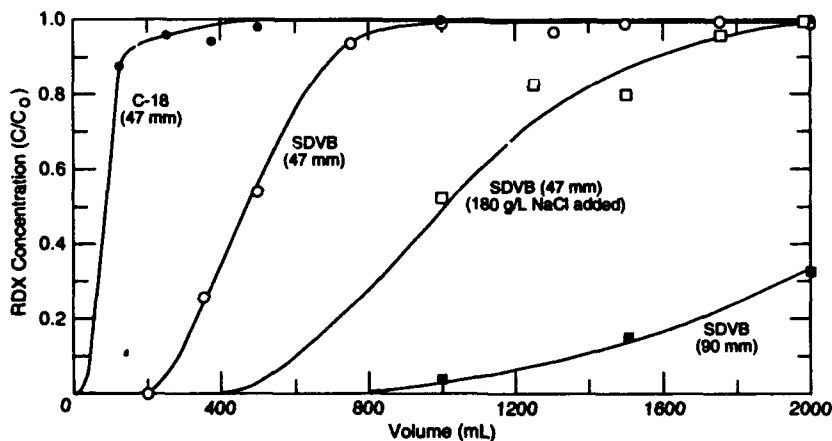

Figure 4. Breakthrough curves for RDX using solid phase extraction with SDVB Empore extraction membrane.

repeated the experiment. The volume at which the effluent concentration was equal to the inflow concentration was increased from about 1.0 to about 2.0 L (Fig. 4). An even larger increase in RDX retention was observed when the same test was repeated without added sodium chloride, but using a 90-mm SDVB membrane (Fig. 4). After 2.0 L had passed through the 90-mm membrane, the effluent RDX concentration was only about 30% of the inflow concentration and this increased to only about 50% even after 10 L had passed through the membrane.

Assessment of alternatives

The major goal of this work is to develop a colorimetric screening procedure that can detect TNT and RDX at $2 \mu\text{g L}^{-1}$ (health advisory levels) in water within a reasonable sample processing time (about 1 hour). The cartridge-based method was constrained by a maximum flow rate of 10 mL min^{-1} , which limited sample size to about 500 mL. While $5 \mu\text{g L}^{-1}$ was detectable, we could not reproducibly detect lower concentrations. Acceptable flow rates for the membrane are much higher and so the sample volume can be larger. Thus, the membrane approach had a greater potential to satisfy the desired detection criteria within time constraints. We therefore concentrated on development of the membrane technique.

Since more often than not, TNT and RDX contaminate groundwater together, the following discussion is based on the assumption that both tests would be conducted for a given sample. If a single membrane is used, the extract from membrane solid phase extraction would be split into two aliquots, one used for the TNT test and the other for the RDX test. When several analytes are present in the acetone extracts, it is important that they do not interfere with each other. Earlier work with the soil method did not show that RDX interferes in any way with the TNT test (Jenkins 1990), and results obtained since have confirmed this conclusion. There was an indication, though, that the presence of TNT did have an effect on the color developed for the RDX test (Walsh and Jenkins 1991). So, we conducted some additional tests that demonstrated that if any TNT is present the color obtained for the RDX test was modified from pink to purple, yellow or orange, depending on the absolute concentrations.

Since TNT and RDX are often co-contaminants in groundwater, TNT in the extract from Solid Phase Extraction (SPE) can significantly interfere with the RDX test. In an attempt to eliminate this

problem, we decided to investigate the use of two membranes in series. In this approach, a 2-L aqueous sample would be drawn through a stack of two 47-mm SDVB membranes and any TNT in the sample would be retained on the top membrane. Since the concentration of RDX in the effluent equals that in the inflow after 1 L for a single membrane, the amount of RDX retained on the bottom membrane should be approximately equal to that in the top membrane after 2 L have passed through a stack of two membranes. This was confirmed experimentally. Thus, the extract from the bottom membrane can be used for RDX determination without any interference from TNT because TNT should be completely retained on the top membrane. The extract of the top membrane will contain both TNT and RDX, but since RDX does not interfere in the TNT test, this extract can be used for the TNT method. This approach seems more useful than the alternative of either using salt or a 90-mm membrane to increase the recovery of RDX. For those cases where RDX may be expected to be present, but TNT is not, use of the 90-mm membrane to improve extraction efficiency for RDX is a reasonable alternative. Adding salt, even if reagent grade, increases the viscosity of the solution, slowing extraction significantly.

The following method is developed on the basis of use of a stack of two 47-mm SDVB membranes. Because they can be plugged if a significant amount of suspended matter is present in the water, a 47-mm glass fiber filter was added on top of the two 47-mm SDVB membranes (Fig. 5). We envisioned that if plugging took place, the filter could be removed and replaced without sample loss.

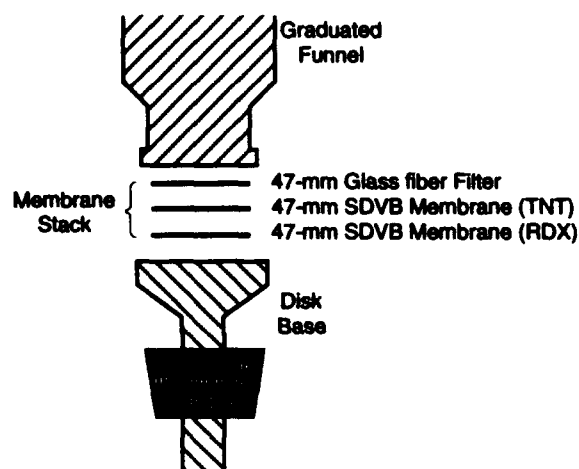

Figure 5. Membrane stack used for membrane solid phase extraction.

RDX recovery from membranes using two-membrane approach

A study was conducted to determine the percent recovery of RDX from the bottom membrane using the two membrane approach described above. Three aqueous solutions were prepared with RDX concentrations at 3, 10 and 50 $\mu\text{g L}^{-1}$. A 2.0-L aliquot of each solution was drawn through two 47-mm SDVB membranes covered with a 47-mm glass fiber filter. In each case the filter was discarded, the top membrane removed and the bottom membrane eluted with 5.0 mL of acetone. Each extract was analyzed using the RDX colorimetric procedure described previously. Recoveries were 25, 20 and 25%, respectively, which was approximately equal to the recovery of RDX from extracts of the top membranes. Thus, recovery does not appear to be a function of concentration. Calibration can be obtained by drawing a 2.0-L volume of RDX standard solution through a two membrane stack and using the bottom membrane for obtaining the RDX response factor.

Test of glass fiber filter

A further test was conducted to see if the glass fiber filters can effectively reduce or eliminate membrane plugging by particulate matter without loss of either TNT or RDX. We did this by preparing a 2.0-L aqueous solution containing 2.0 $\mu\text{g L}^{-1}$ of TNT and 2.0 $\mu\text{g L}^{-1}$ of RDX, and adding 20 mg L^{-1} of Morin clay. This produced a sample with noticeable turbidity, comparable to what is sometimes obtained from a groundwater well during sampling. The suspension was drawn through a SPE membrane stack (Fig. 5) and the filter plugged rapidly, dramatically reducing the flow rate. The filter was replaced three times (total of four filters used) before the entire 2.0-L sample could be extracted. The filters were discarded and the bottom membrane used to assess RDX recovery and the top membrane used for TNT recovery.

Recoveries for RDX and TNT were not significantly affected by the presence of the clay or its removal by the glass fiber filters. Thus, the use of the glass fiber filters does not seem to reduce analyte recovery and does reduce membrane plugging.

Water content of membranes after extraction

Water present in membranes after sample extraction will become a component of the acetone extracts. Water in the acetone is known to affect the degree of color development in the TNT test (Jenkins 1990) and the rate of RDX reduction to nitrous acid in the RDX test (Walsh and Jenkins 1991). There-

fore, an experiment was run to see if the amount of water retained by the SDVB membranes after extraction and before elution with acetone was appropriate for the two colorimetric procedures.

This study was conducted gravimetrically by weighing the membrane before and after pulling 250 mL of water through the stack of membranes and filter. Weights increased by a mean value of 0.57 g and the reproducibility from membrane to membrane was 0.02 g. This weight was not drastically affected by the length of time air was drawn through the membrane after the sample was extracted.

If the membrane was then eluted with 5 mL of acetone, and assuming all the water was displaced, the percentage of water in the acetone would be 11% by weight, which would be in an acceptable range for the RDX test. If 20 mL of acetone was used for elution, as could be the case for the TNT method, the percentage of water in the acetone would be 3%, also an acceptable water content for the TNT test. This level of water appears to be sufficiently reproducible that adding additional water is unnecessary.

Elution of analytes from the membranes

Once water samples are extracted using the membranes, the extracted analytes are eluted from the membrane with acetone. The following experiment was conducted to find the volume of acetone required to elute the extracted analytes from the membrane. A 2.0-L aliquot of test solution containing TNT (10 $\mu\text{g L}^{-1}$) and RDX (50 $\mu\text{g L}^{-1}$) was extracted through the two-membrane stack. The top membrane was removed, and the bottom membrane was eluted sequentially with three 5.0-mL aliquots of acetone, which were collected separately. The bottom membrane was then removed and the top membrane replaced. The top membrane was then eluted with a 10.0-mL aliquot of acetone.

We analyzed the extracts from the bottom membrane using the colorimetric RDX test, finding that 98% of the recoverable RDX was present in the first 5-mL extract. We also analyzed the 10-mL extract from the top membrane using the colorimetric TNT test, recovering 100% of the TNT. Thus, 5 mL of acetone is adequate for RDX elution from the bottom membrane and 10 mL of acetone is adequate for elution of TNT from the top membrane.

Recovery of TNT and RDX from other water matrices

To determine if the recovery of TNT and RDX, using the two membrane approach, was indepen-

dent of the water matrix, we obtained samples of water from a deep groundwater well, the Connecticut River, and a pond near Lebanon, New Hampshire. The samples were fortified with TNT and RDX at $2.0 \mu\text{g L}^{-1}$.

A 2.0-L aliquot of the well water was extracted with the SPE membrane stack, as described above, and RDX and TNT determined colorimetrically. Results indicated that recovery was equivalent to that obtained using reagent grade water.

The results for the two surface waters were very different. Even using the glass fiber filter, or a glass bead ($40\text{-}\mu\text{m}$) depth filter as recommended by 3M Corporation, plugging of the membranes prohibited sampling more than 500 mL. Since only 500 mL could be processed, absorbance measurements were too low to assess recovery using the $2.0\text{-}\mu\text{g L}^{-1}$ experiment described. So, a second experiment was run with 2.5 L of pond water on a single 90-mm SDVB membrane. The concentration of TNT and RDX was $40 \mu\text{g L}^{-1}$. This test indicated that four times as much acetone was needed to elute the TNT from the membrane, and the extract was highly colored, which caused interferences with the colorimetric determinations. The source of this color appears to be dissolved and colloidal organic material present in the pond water that penetrated deep within the membrane, and a portion of which was eluted with the acetone. The same phenomenon was observed with the river water. Thus, without some additional step to remove this interference, the membrane approach is not particularly useful for TNT or RDX in surface waters, but does a good job for groundwater, which is the principal matrix of interest here. The test would also presumably work with process water derived from a potable water source, although no tests with this type of matrix were conducted.

Spot test for TNT

Our inability to extract sufficient surface water using SDVB membranes led us to develop of a simple spot test for TNT. After 0.5 L water is extracted and the vacuum allowed to pull air through the membrane for 1 minute, the vacuum is released and the glass fiber filter removed to expose the top membrane. One drop of EnSys TNT reagent (EnSys Corporation, Research Triangle Park, North Carolina) is applied to the edge of the wetted part of the disk (there is no need to add extra acetone). Pink will show in a few seconds, which indicates the presence of more than $2 \mu\text{g L}^{-1}$ TNT in the sample. The unwetted part of the disk will serve as the

blank and should remain colorless. This color is visible even when brown deposits from surface waters are present. Other nitroaromatics (TNB, DNB, 2,4 DNT) that produce a color with this reagent should also be detectable, but were not tested. If quantitation is still desired, the disk can be washed with 10 mL of deionized water and the standard 2-L extraction continued with the remaining sample. The spot test does not preclude the standard TNT and RDX tests. Thus, this approach may be used to screen surface water samples for TNT at the microgram-per-liter level.

Modification of RDX determination

Our initial tests with the 5-mL extract from $2.0\text{-}\mu\text{g L}^{-1}$ samples were conducted using the procedure described by Walsh and Jenkins (1991). In this procedure the 5-mL extract is acidified with 0.5 mL of acetic acid and added to the barrel of a syringe containing zinc dust. After a 15-second reaction time, the solution is filtered into 20 mL water. With the $2.0\text{-}\mu\text{g L}^{-1}$ samples, we were unable to obtain reproducible results as judged by the development of a visually detectable pink color. While the capacity of the cuvettes used for absorbance measurements is 25 mL, only 20 mL is necessary to allow absorbance measurements using the cuvettes commercially available from Hach.* To make the method as sensitive as possible, we modified it slightly by filtering the zinc-reacted acetone extract into 15 mL of water rather than 20 mL to obtain a final volume of 20 mL. Resulting absorbances were about 20% higher and resulted in a visually detected pink color for all $2.0\text{-}\mu\text{g L}^{-1}$ extracts. About half of the reactions that we attempted in the syringe barrel, however, either dripped extract prematurely or became plugged with zinc and remained in the syringe too long. Since timing is critical to the reproducibility of this reaction (Walsh and Jenkins 1991), the alternative of reducing the RDX with zinc and acetic acid in the collection tube, followed by syringe-filtering, was tried. Relative standard deviations of replicate standards fell from 13 to 4.7% using this modification. Thus, for Method Detection Limit tests (MDL), this modification was used.

Modification of TNT determination

Results discussed above indicated that 10 mL of acetone is sufficient to elute the retained TNT from

* While smaller cuvettes could be fabricated, our method development activities were constrained to work with commercially available instrumentation.

the membrane. As mentioned, the cuvette used in the Hach spectrophotometer has a 25-mL capacity but a 20-mL volume is adequate to allow absorbance measurements. A 20-mL volume was therefore used in the TNT procedure to make the method as sensitive as possible.

Method detection limit and qualitative detection tests

MDL is defined as the "minimum concentration of a substance that can be measured and reported with 99% confidence that the analyte concentration is greater than zero and is determined from analysis of a sample in a given matrix containing the analyte" (Federal Register 1984). After estimating the MDL from instrument responses, a set of at least seven replicate samples is prepared with the analyte concentrations in the range of one to five times the estimated MDL. These samples are then processed through the entire analytical procedure and the standard deviation obtained. The MDL is calculated by multiplying the standard deviation of the replicate measurements by the one-sided *t*-statistic corresponding to *n*-1 degrees of freedom at the 99% confidence level.

MDLs for the TNT and RDX screening methods were obtained as follows. A 20-L aqueous solution was prepared with TNT and RDX concentrations at 5.0 µg L⁻¹ by diluting stock standards of TNT and RDX in reagent grade water. Seven replicate 2.0-L samples were extracted using the SDVB membrane stacks (47-mm glass fiber filter and two 47-mm SDVB membranes). The extraction process took about 50 minutes for each sample, with a resulting flow rate of about 40 mL min⁻¹. After extraction, the glass fiber filter was discarded and the top membrane removed and placed in a plastic weigh boat. The bottom membrane was eluted with 5.0 mL of acetone and the extract processed using the RDX procedure described above. The bottom membrane was then removed; the top membrane was replaced on the filter funnel and eluted with 20 mL of acetone. This extract was processed by the TNT procedure described above. Individual absorbances obtained, mean concentrations and standard deviations for TNT and RDX are presented in Table 2, with resulting MDLs of 0.91 µg L⁻¹ for TNT and 3.8 µg L⁻¹ for RDX. We acquired the response factors used for calibration from the absorbances obtained when a standard containing TNT and RDX at 40 µg L⁻¹ was run through the entire procedure.

The result for TNT was adequate to allow quantitation below the target value of 2 µg L⁻¹ (Table 1). The result for RDX was inadequate for measure-

ment at 2 µg L⁻¹ according to the MDL, because of the degree of random error obtained. The sensitivity, in terms of absorbancy, however, appeared adequate to detect RDX visually at the 2.0-µg L⁻¹ concentration. To assess our ability to detect RDX at 2.0 µg L⁻¹, we processed five replicate samples of reagent grade water containing RDX and TNT at 2.0 µg L⁻¹ as described above. Five 2.0-L reagent grade water blanks were also processed in an identical fashion. The extracts from the top and bottom membranes from all ten tests were subjected to the colorimetric tests described above and the resulting solutions assessed visually by five people. In all cases, solutions resulting from samples with TNT and RDX present were identified as colored and the five blank samples identified correctly. Thus, both TNT and RDX can be screened successfully at the 2.0-µg L⁻¹ level using this procedure and visual detection, but reliable quantification is only possible for TNT at that concentration.

Practical considerations

Membranes will shed SDVB beads if the vacuum is applied too suddenly. These particles interfere with quantification by adding turbidity and removing color. Care must be taken to avoid membrane damage. If the acetone extract is cloudy, it must be filtered before reacting with reagents to avoid color loss. Membranes can be reused since the elution and subsequent restart rinses remove all analytes. However, they show reduced flow even with the glass fiber filter and reagent grade water. Two or three samples of well water is a likely maximum. Acetone wetted membranes will stick to plastic when they dry, so those to be reused should be placed on Parafilm.

Table 2. Results from MDL test for reagent grade water samples containing TNT and RDX at 5.0 µg/L.

Replicate	Found concentration (µg/L)			
	TNT		RDX	
	Absorbance	Concentration	Absorbance	Concentration
1	0.061	4.09	0.051	4.60
2	0.053	3.55	0.037	3.34
3	0.063	4.22	0.040	3.61
4	0.055	3.69	0.037	3.34
5	0.064	4.29	0.073	6.58
6	0.057	3.82	0.058	5.23
7	0.062	4.15	0.058	5.23
X	—	3.97	—	4.56
% recovery	—	90%	—	28%
S	—	0.29	—	1.22
<i>t</i>	—	3.14	—	3.14
MDL	—	0.91	—	3.83

RECOMMENDED METHOD

Two Empore SDVB extraction membranes are placed on a filter funnel. One GF/F glass fiber filter is placed on top and the funnel reservoir clamped in place (Fig. 5). A 10-mL portion of acetone is added and allowed to soak into the filter stack for 3 minutes. Vacuum is then applied and 10 mL of deionized water is added just before the last acetone penetrates into the membrane. Likewise, the sample is added just before the last of the deionized water penetrates, refilling the reservoir as needed to keep it from running dry. After the last of the 2-L sample has been extracted, vacuum is continued for a few minutes to remove excess water. The GF/F filter is discarded and the top SDVB membrane set aside. The reservoir is replaced and 5.0 mL acetone is added. After a 3-minute soak, vacuum is applied and the acetone is drawn into a 25- \times 200-mm tube that has been placed under the funnel (Fig. 2). The bottom SDVB membrane is then removed from the filter funnel and the top membrane replaced and treated in like manner using 20 mL of acetone.

To determine RDX, 0.5 mL of glacial acetic acid and 0.2 g of zinc dust are added to the extract from the bottom membrane. After 10 seconds, the reaction mixture is poured into a 10-mL syringe and filtered through a 0.5- μ m Millex SR filter into 15 mL of deionized water in a 22-mL scintillation vial. One Hach NitriVer3 powder pillow is added and then the vial is shaken briefly. After 15 minutes, the sample is filtered through a 0.5- μ m Millex SR filter into a cuvette and the absorbance is read at 507 nm. The color should also be noted. An aqueous concentration of 2 μ g L⁻¹ will reliably produce a faint pink color when compared to a reagent blank. The spectrophotometer is zeroed on acetone. One reagent blank is run during the day and its absorbance subtracted from the sample absorbances. The blank should be run after 15 minutes, since the absorbance rises as time passes (e.g., from 0.005 to 0.014 in 7 hours). Absorbance is linear with concentration to 0.700 A.U.

To determine TNT, the acetone extract from the top disk is used. If the extract is cloudy, it must be filtered. An initial absorbance at 540 nm is read. The extract is then poured back into the collection tube and one pellet of potassium hydroxide and 0.2 g of sodium sulfite is added. A drop of Ensyt TNT color developing reagent can be substituted for the potassium hydroxide and sodium sulfite. The tube is shaken continuously for 3 minutes. The reaction mixture is filtered through a 0.5- μ m Millex SR filter into a cuvette and the absorbance read at

540 nm. Color is noted. Various nitroaromatics produce different colors (Jenkins and Walsh 1991). The spectrophotometer is zeroed on acetone. The initial absorbance is doubled and subtracted from the reacted absorbance (Jenkins 1990). Absorbance is linear with concentration to at least 0.600 A.U.

Absorbance values for RDX and TNT are converted to microgram-per-liter values based on a daily calibration standard. This standard is made by spiking 2 L of deionized water at 40 μ g L⁻¹ TNT and RDX using 80 μ L each of 1000 mg L⁻¹ acetone stock solutions dispensed from a glass syringe. The presence of 160 μ L of acetone has no effect on recovery of either analyte. This calibration standard is treated as a sample and the absorbances obtained for TNT and RDX should fall in the following ranges: TNT 0.60 \pm 0.02 and RDX 0.46 \pm 0.10. To calculate sample concentrations

$$\text{TNT } (\mu\text{g L}^{-1}) = \text{Absorbance} \times 67$$

and

$$\text{RDX } (\mu\text{g L}^{-1}) = \text{Absorbance} \times 90.$$

CONCLUSIONS

The colorimetric screening methods described above were developed for the situation where results for TNT and RDX are desired from a common groundwater sample. The stack of two membranes is useful because it allows the processing of an extract from the bottom membrane for the RDX test, which is free of TNT, a possible interference. In addition, this procedure develops two separate extracts for the two tests and thus a common extract is not split, reducing the sensitivity of both methods.

The SDVB membranes have been shown to be quite effective for preconcentration of TNT prior to colorimetric determination. The method we describe above specifies the use of a 2.0-L sample but at least 10 L of water can be passed through a 47-mm membrane without significant TNT breakthrough. The 2.0-L sample was adequate to allow detection of TNT below the 2- μ g L⁻¹ criteria limit (MDL = 0.9 μ g L⁻¹). Because the recovery of TNT using the SDVB membranes is near quantitative, calibration for TNT can be obtained as described by processing a calibration solution in the same manner as a sample or, alternatively, by running an acetone standard solution that contains the appropriate amount of water (3 mL of water per 100 mL of acetone [Jenkins 1990]).

The SDVB membranes are not nearly as efficient at preconcentration of RDX as they are for

TNT. This, and the potential interference of TNT in the RDX method, were the major technical challenges in this method development program. Using the HayeSep R cartridge, RDX recovery for a 500-mL sample was near quantitative but the resulting preconcentration was inadequate to allow detection at the $2\text{-}\mu\text{g L}^{-1}$ target level. Processing additional water through the cartridge was considered to be impractical since efficient recovery is achieved only at flow rates of 10 mL m^{-1} or less and processing of 2 L would take over 3 hours for the preconcentration step alone. In addition, TNT could also be present in the extract and it can interfere with the RDX test.

The use of a single SDVB membrane for RDX preconcentration was found to be inadequate for this application since, here again, TNT could not be removed from the extract and hence could interfere in the RDX test. The use of a stack of two membranes was successful in eliminating the potential for TNT interference but it must be remembered that the recovery of RDX on the bottom membrane averages only about 28% and the reproducibility of this recovery from membrane to membrane is poor. The result of this poor precision is a method detection limit that exceeds the $2.0\text{-}\mu\text{g L}^{-1}$ target value. The sensitivity of the colorimetric test is adequate to allow reproducible visual detection at $2.0\text{ }\mu\text{g L}^{-1}$, however, and qualitative use for screening at a $2.0\text{-}\mu\text{g L}^{-1}$ level is therefore possible.

LITERATURE CITED

- Bicking, M.K.L. (1987) Evaluation of solid sorbent technology. Aberdeen Proving Ground, Maryland: U.S. Army Toxic and Hazardous Materials Agency. Final Report from Contract No. DAAG29-81D-0100.
- Federal Register (1984) Definition and procedure for the determination of the method detection limit. Code of Federal Regulations, Part 136, Appendix B, October 26.
- Fetterolf, D.D., J.L. Mudd and K. Teten (1991) An enzyme-linked immuno-sorbent assay (ELISA) for trinitrotoluene (TNT) residue on hands. *Journal of Forensic Science*, 36: 343-349.
- Grant, C.L., T.F. Jenkins and S.M. Golden (1993) Evaluation of pre-extraction analytical holding times for nitroaromatics and nitramines explosives in water. USA Cold Regions Research and Engineering Laboratory, Special Report 93-24.
- Haas, R. and G. Stork (1989) Konzrpt zur Untersuchung von Rustungsaltslasten: 1. Untersuchung ehemaliger TNT-Fabriken und Fullstellen. *Fresenius Journal of Analytical Chemistry*, 335: 839-846.
- Haas, R., I. Schreiber, E. von Low and G. Stork (1990) Conception for the investigation of contaminated munition plant wastes: 2. Investigation of former RDX-plants and filling stations. *Fresenius Journal of Analytical Chemistry*, 338: 41-45.
- Hagen, D.F., C.G. Markell and G.A. Schmitt (1990) Membrane approach to solid-phase extraction. *Analytica Chimica Acta*, 236: 157-164.
- Heller, C.A., S.R. Grenl and E.E. Erickson (1982) Field detection of 2,4,6-trinitrotoluene in water by ion-exchange resins. *Analytical Chemistry*, 54: 286-289.
- Hutter, L., G. Teaney and J.W. Stave (1993) A novel field screening system for TNT using EIA. In *Field Screening Methods for Hazardous Wastes and Toxic Chemicals, Proceedings of the 1993 U.S. EPA International Symposium*, vol. 1, p. 472.
- Jenkins, T.F. (1990) Development of a simplified field method for the determination of TNT in soil. USA Cold Regions Research and Engineering Laboratory, Special Report 90-38.
- Jenkins, T.F. and P.W. Schumacher (1990) Evaluation of a field kit for detection of TNT in water and soils. USA Cold Regions Research and Engineering Laboratory, Special Report 90-20.
- Jenkins, T.F. and M.E. Walsh (1991) Field screening method for 2,4-dinitrotoluene in soil. USA Cold Regions Research and Engineering Laboratory, Special Report 91-17.
- Jian, C. and W.R. Seitz (1990) Membrane for in situ optical detection of organic nitro compounds based on fluorescence quenching. *Analytica Chimica Acta*, 237: 265-271.
- Keuchel, C., L. Weil and R. Niessner (1992a) Effect of the variation of the length of the spacer in a competitive enzyme immunoassay (ELISA) for the determination of 2,4,6-trinitrotoluene (TNT). *Fresenius Journal of Analytical Chemistry*, 34: 143.
- Keuchel, C., L. Weil and R. Niessner (1992b) Enzyme-linked immuno assay for the determination of 2,4,6-trinitrotoluene and related nitroaromatic compounds. *Analytical Sciences*, 8: 9-12.
- Pugh, D.L. (1982) Milan Army Ammunition Plant contamination survey. Aberdeen Proving Ground, Maryland: USA Toxic and Hazardous Materials Agency, Report DRXTH-FR-8213.
- Spaulding, R.F. and J.W. Fulton (1988) Groundwater munition residues and nitrate near Grand Island, Nebraska, U.S.A. *Journal of Contaminant Hydrology*, 2: 139-153.
- Stevanovic, S. and M. Mitrovic (1990) Colorimetric

method for semiquantitative determination of nitroorganics in water. *International Journal of Environmental Analytical Chemistry*, 40: 69-76.

U.S. Environmental Protection Agency (1988) Health advisory for RDX. Washington, D.C.: Criteria and Standards Division, Office of Drinking Water.

U.S. Environmental Protection Agency (1989) Trinitrotoluene health advisory. Washington, D.C.: Office of Drinking Water.

U.S. Environmental Protection Agency (1992) Nitroaromatics and nitramines by HPLC. Second Update, SW846 Method 8330.

Valis, R.J., T.A. Bishop and K.E. Williams (1989) Validation of a sorbent tube/high-performance liquid chromatographic procedure for the determination of eight explosives in water. Aberdeen Proving Ground, Maryland: U.S. Army Environmental Hygiene Agency (AEHA), Final Report AD-A210777

Walsh, M.E. and T.F. Jenkins (1991) Development of a field screening method for RDX in soil. USA

Cold Regions Research and Engineering Laboratory, Special Report 91-7.

Walsh, M.E., T.F. Jenkins, P.S. Schnitker, J.W. Elwell and M.H. Stutz (1993) Evaluation of SW846 Method 8330 for characterization of sites contaminated with residues of high explosives. USA Cold Regions Research and Engineering Laboratory, CRREL Report 93-5.

Yinon, J. and S. Zitrin (1993) *Modern Methods Applications in Analysis of Explosives*. New John Wiley and Sons.

Zhang, Y. and W.R. Seitz (1989) Single fiber absorption measurements for remote detection of 2,4,6-trinitrotoluene. *Analytica Chimica Acta*, 221: 1-9.

Zhang, Y., W.R. Seitz, C.L. Grant and D.C. Sunberg (1989) A clean, amine-containing poly(vinyl)chloride membrane for in-situ optical detection of 2,4,6-trinitrotoluene. *Analytica Chimica Acta*, 217: 217-227.

REPORT DOCUMENTATION PAGE

Form Approved
OMB No. 0704-0188

Public reporting burden for this collection of information is estimated to average 1 hour per response, including the time for reviewing instructions, searching existing data sources, gathering and maintaining the data needed, and completing and reviewing the collection of information. Send comments regarding this burden estimate or any other aspect of this collection of information, including suggestion for reducing this burden, to Washington Headquarters Services, Directorate for Information Operations and Reports, 1215 Jefferson Davis Highway, Suite 1204, Arlington, VA 22202-4302, and to the Office of Management and Budget, Paperwork Reduction Project (0704-0188), Washington, DC 20503.

1. AGENCY USE ONLY (Leave blank)	2. REPORT DATE May 1994	3. REPORT TYPE AND DATES COVERED	
4. TITLE AND SUBTITLE Field Screening Method for TNT and RDX in Groundwater		5. FUNDING NUMBERS	
6. AUTHORS Thomas F. Jenkins, Philip G. Thorne and Marianne E. Walsh		8. PERFORMING ORGANIZATION REPORT NUMBER Special Report 94-14	
7. PERFORMING ORGANIZATION NAME(S) AND ADDRESS(ES) U.S. Army Cold Regions Research and Engineering Laboratory 72 Lyme Road Hanover, New Hampshire 03755-1290		10. SPONSORING/MONITORING AGENCY REPORT NUMBER SFIM-AEC-TS-CR-94034	
9. SPONSORING/MONITORING AGENCY NAME(S) AND ADDRESS(ES) U.S. Army Environmental Center Aberdeen Proving Ground, Maryland		11. SUPPLEMENTARY NOTES	
12a. DISTRIBUTION/AVAILABILITY STATEMENT Approved for public release; distribution is unlimited. Available from NTIS, Springfield, Virginia 22161.		12b. DISTRIBUTION CODE	
13. ABSTRACT (Maximum 200 words) <p>Two field screening methods were developed to determine TNT and RDX in groundwater. Both methods rely on solid phase extraction to remove analytes from the water and effect preconcentration. For the first method, a 500-mL water sample is passed through a 3-mL solid phase extraction cartridge packed with HayeSep R. TNT and RDX are then eluted from the cartridge with acetone and the extract divided into two portions. One portion of the extract is reacted with acetic acid and zinc to convert RDX to nitrous acid. The nitrous acid is converted to an azo dye with a Griess reagent and the concentration estimated by the absorbance at 507 nm (Griess method). The second portion of the extract is reacted with a pellet of KOH and about 0.3 mg of sodium sulfite. The concentration of TNT is estimated from the absorbance at 540 nm of the Janowsky anion (Janowsky method). Using these methods, and visual detection of the colored solutions produced, samples containing 5 µg L⁻¹ of either TNT or RDX can be reliably distinguished from uncontaminated water. In the second method, a 2-L water sample is passed through a stack of two 47-mm Empore SDVB disks to preconcentrate TNT and RDX. The top disk is removed, the bottom disk eluted with 5 mL of acetone and the extracted RDX determined using the Griess method described above. The top disk is then replaced and eluted with 20 mL of acetone and the extracted TNT determined by the Janowsky method described above. Using these methods and visual detection of the colored</p>			
14. SUBJECT TERMS Analysis Explosives Field analysis		Field screening Nitramines Nitroaromatics	RDX TNT Water
17. SECURITY CLASSIFICATION OF REPORT UNCLASSIFIED		18. SECURITY CLASSIFICATION OF THIS PAGE UNCLASSIFIED	15. NUMBER OF PAGES 19
19. SECURITY CLASSIFICATION OF ABSTRACT UNCLASSIFIED		16. PRICE CODE	
20. LIMITATION OF ABSTRACT UL		17. SECURITY CLASSIFICATION OF ABSTRACT UNCLASSIFIED	

13. ABSTRACT (cont'd)

solutions, water samples containing $2 \mu\text{g L}^{-1}$ of either TNT or RDX can be reliably distinguished from uncontaminated water. For quantitative analysis, use of these methods and absorbance measurements with a spectrophotometer resulted in Method Detection Limits (MDL) of $0.9 \mu\text{g L}^{-1}$ for TNT, but a higher value of $3.8 \mu\text{g L}^{-1}$ for RDX. The higher MDL for RDX is caused by poor reproducibility in RDX recovery from the bottom membrane.