

AD-A284 382



Technical Document 2664
July 1994

High-Frequency Skywave Signal Power Measurement System

Richard Sprague
William Moision
NRaD

John Theisen
Science and Technology Corp.



94-29992



Approved for public release; distribution is unlimited.

DTIC QUALITY CONTROL

94 9 17

50

**Best
Available
Copy**

Technical Document 2664

July 1994

High-Frequency Skywave Signal Power Measurement System

Richard Sprague

William Moision

NRaD

John Theisen

Science and Technology Corp.

**NAVAL COMMAND, CONTROL AND
OCEAN SURVEILLANCE CENTER
RDT&E DIVISION
San Diego, California 92152-5001**

**K. E. EVANS, CAPT, USN
Commanding Officer**

**R. T. SHEARER
Executive Director**

ADMINISTRATIVE INFORMATION

The work described in this report was performed under the Atmospheric Effects Assessment Program, which is managed by the Naval Command, Control and Ocean Surveillance Center. RDT&E Division (NRaD), and sponsored by the Office of Naval Research.

Released by
J. A. Ferguson, Head
Ionospheric Branch

Under authority of
J. H. Richter, Head
Ocean and Atmospheric
Sciences Division

ACKNOWLEDGMENTS

We acknowledge the cooperation of the personnel of the Navy Radio Receiving Facility, Imperial Beach, California, and the personnel of the Air Force Vananda Radar Site (Det 18), Forsyth, Montana. We especially acknowledge USAF Master Sergeants Thornberry and Dilley in Forsyth for their efforts in installing and maintaining the transmission installation.

EXECUTIVE SUMMARY

OBJECTIVES

Verify high-frequency (HF) models for prediction of signal strength, signal-to-noise ratio, and circuit reliability. Derive model of the short-term variability of signal strength.

METHOD

Establish a transmission path for making high time resolution measurements of received power and transmission loss. Use collected data to verify current models and develop new models.

RESULTS

A transmission circuit was established between Forsyth, Montana, and Imperial Beach, California. Transmitting and receiving systems were designed and built. Software was developed for computer control of both transmitting and receiving systems. Measurements of received power at three selected frequencies in the HF band was begun in late December 1993.

Accession For	
NTIS GRA&I	<input checked="" type="checkbox"/>
DTIC TAB	<input type="checkbox"/>
Unannounced	<input type="checkbox"/>
Justification	
By _____	
Distribution Statement	
Availability Codes	
Dist	Avail and/or Special
A1	

CONTENTS

EXECUTIVE SUMMARY	iii
INTRODUCTION	1
TRANSMITTING SYSTEM	2
RECEIVING SYSTEM	5
MEASUREMENTS	8
DATA SAMPLES	9
CONCLUSION	19

FIGURES

1. Relative locations of the transmitter site (Vananda), receiver site (Imperial Beach), and approximate path mid-point (Salt Lake City).	2
2. Transmitter system.	3
3. Transmit schedule for received power measurements.	4
4. Receiver system.	5
5. Smith Chart showing input impedance of antenna for 3.35-MHz signal (Marker 2).	6
6. Smith Chart showing input impedance of antenna for 7.8-MHz signal (Marker 1).	7
7. Smith Chart showing input impedance of antenna for 14.4-MHz signal (Marker 1).	7
8. Received power for 3.35 MHz at 00:20:15 PST on 1 January 1994.	10
9. Received power for 7.8 MHz at 00:20:15 PST on 1 January 1994.	10
10. Received power for 14.4 MHz at 00:20:15 PST on 1 January 1994.	11
11. Received power for 3.35 MHz at 12:00:15 PST on 1 January 1994.	11
12. Received power for 7.8 MHz at 12:00:15 PST on 1 January 1994.	12
13. Received power for 14.4 MHz at 12:00:15 PST on 1 January 1994.	12
14. Oblique ionograms taken during sweeps corresponding to figures 8 through 10 (top) and figures 11 through 13 (bottom).	13
15. Median signal-to-noise ratios at 3.35 MHz from 29 December 1993 to 1 January 1994.	15
16. Median signal-to-noise ratios at 7.8 MHz from 29 December 1993 to 1 January 1994.	15

17. Median signal-to-noise ratios at 14.4 MHz from 29 December 1993 to 1 January 1994.	16
18. Median noise power at 3.35 MHz from 29 December 1993 to 1 January 1994.	16
19. Median noise power at 7.8 MHz from 29 December 1993 to 1 January 1994.	17
20. Median noise power at 14.4 MHz from 29 December 1993 to 1 January 1994.	17

TABLES

1. Transmitter system losses	5
2. Receive site antenna and system losses	8

INTRODUCTION

In December 1993, a high-frequency (HF) propagation circuit was established between the Air Force Vananda Radar Site near Forsyth, Montana, and the Naval Radio Receiving Facility in Imperial Beach, California, for the purpose of making high time resolution measurements of HF skywave received power. The data collected from this effort will be used to test the accuracy of median propagation model predictions and to quantify the level of short-term variations of received power to improve current and future models of short-term variability.

This report describes the data collection system being used to measure the HF received power, and it presents examples of the measured data. A future report will describe the data analysis procedures and compare the measured data with the predictions.

The choice of the Montana-to-California circuit was driven by two main requirements for this measurement effort. The first requirement was that the receiver be located near the site of the Naval Command, Control and Ocean Surveillance Center, Research, Development, Test and Evaluation Division (NRaD) in San Diego, California. A high time resolution measurement, such as the one being done in this effort, produces a large amount of data that can quickly fill a data storage device. It is thus necessary that personnel be available to routinely change final data storage media. Routine maintenance of the receive site equipment also requires the availability of personnel. Because the Imperial Beach site ($32^{\circ} 36' 18''$ N, $117^{\circ} 7' 42''$ W) is approximately 20 miles south of the NRaD site, these routine functions can easily be accomplished by NRaD personnel.

A more important requirement for the chosen circuit is that a vertical incidence (VI) sounder be located near the mid-point of the path. True electron density height profiles derived from ionograms taken by the VI sounder will be used to define the state of the ionosphere during a measurement period. Take-off and receive angles will be determined for each propagating mode by ray-tracing through the defined ionosphere. These angles will then be used to determine path antenna gain for each mode.

The vertical sounder, owned by Utah State University and operated at their Bear Lake research facility as part of another project at NRaD, is producing ionograms on a schedule that is compatible with the requirements of this effort. To take advantage of that vertical sounder for this project, the Vananda site ($46^{\circ} 21' 14''$ N, $107^{\circ} 0' 23''$ W) was chosen as the transmitter site, since the Bear Lake facility is approximately mid-way between Vananda and Imperial Beach. The orientation of the path is shown in figure 1.

The chosen circuit, which is approximately 1770 km long, is somewhat longer than originally intended. A circuit of 1000 km or less would be desirable in making an assumption of ionospheric uniformity when analyzing the data; however, the lack of a vertical sounder closer to the Imperial Beach site forced the selection of the path of figure 1.

Three measurement frequencies were chosen for this experiment: 3.35 MHz, 7.8 MHz, and 14.4 MHz. The frequencies were selected so that one frequency (3.35 MHz) would be available during the nighttime hours, one frequency (14.4 MHz) would be available during the daytime, and the third frequency (7.8 MHz) would be available both day and night. These assumptions of availability proved to be approximately correct in the data collected to date.

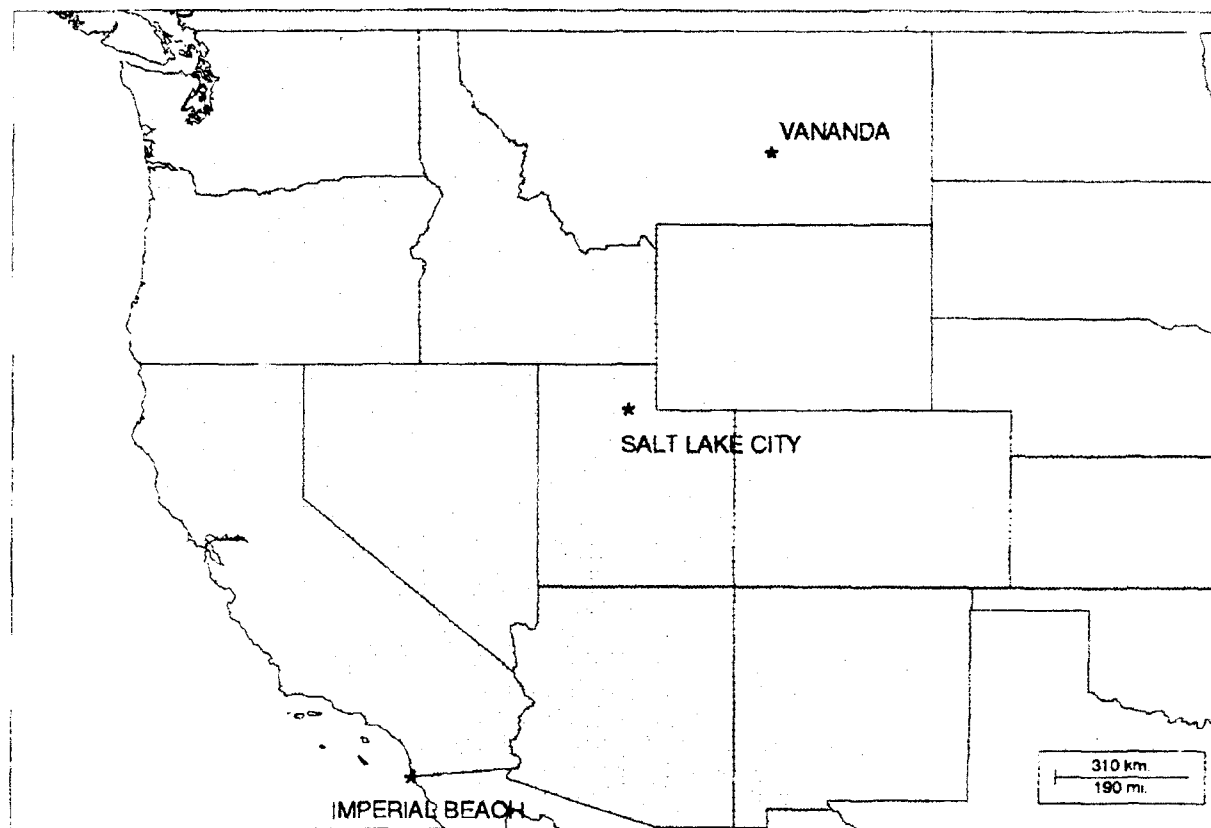

Figure 1. Relative locations of the transmitter site (Vananda), receiver site (Imperial Beach), and approximate path mid-point (Salt Lake City).

TRANSMITTING SYSTEM

A block diagram of the transmission system located in Montana is shown in figure 2. Four vertical monopole antennas have been erected at the site, an approximately 1/4-wavelength antenna (including a 1/4-wavelength, 50-wire radial ground plane) for each of the three transmission frequencies, and a 32-foot antenna for the oblique sounder system that is also deployed on the path.

The 1/4-wavelength antennas are connected via low-loss coaxial cable to the output of an ICOM EX-627 antenna switch, which is connected to the output of a 150-watt (51.76 dBm) ICOM 781 transceiver, which also provides frequency switching for antenna selection (see figure 2). The ICOM 781 also provides automatic tuning of the transmission system to produce minimum VSWR for each frequency. Computer control for the system is provided by a 486-class PC that is connected to the transmitter via an RS-232 serial connection to an ICOM communications interface. Figure 2 shows a 500-watt ICOM 4KL amplifier connected to the output of the transceiver. This amplifier was removed from the transmission system shortly after data collection started in order to simplify the system and improve reliability.

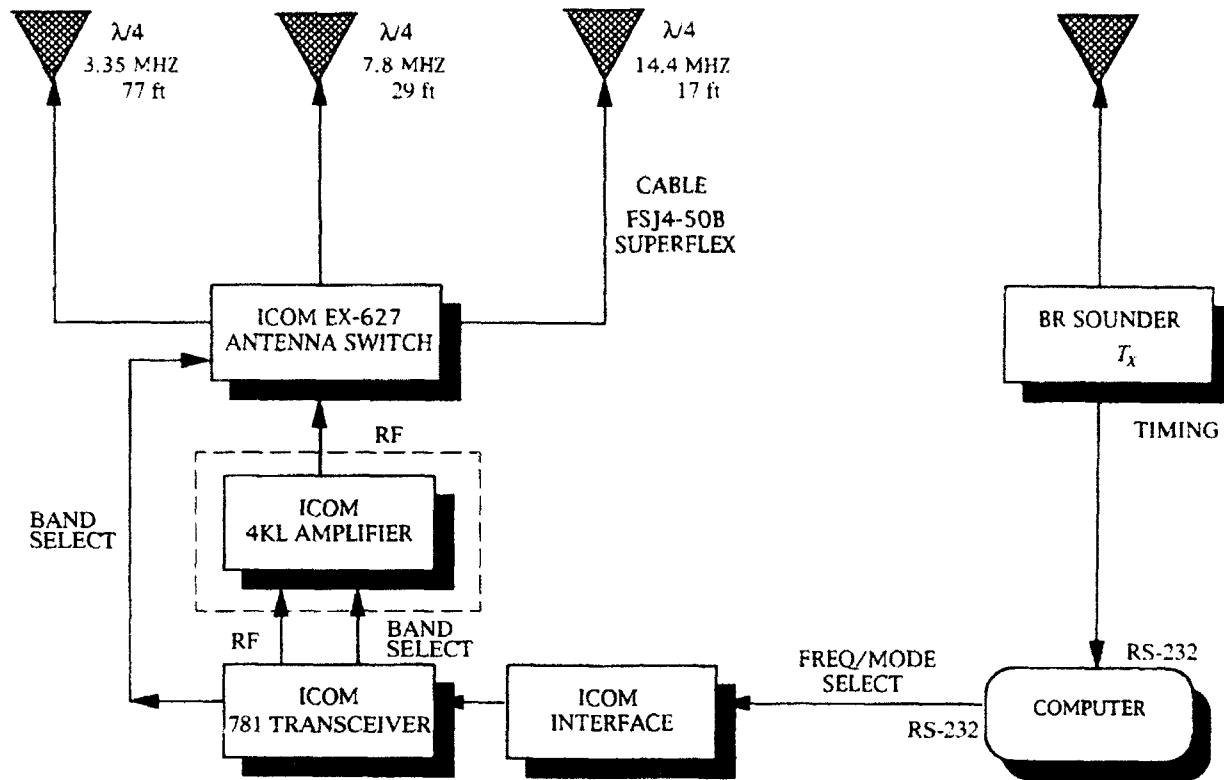

Figure 2. Transmitter system.

Timing for the experiment is provided by an oblique chirp sounder system, which is also deployed on the propagation path. Every 5 minutes, the chirp sounder transmits a 10-watt (40 dBm) signal swept from 2 MHz to 16 MHz, at a rate of 50 kHz/s. The sounder transmitter clock provides timing for the system via an RS-232 serial connection to the computer. The sounder transmission is received at Imperial Beach by an oblique sounder receiver which is synchronous with the transmitter to within 1 second.

The transmission schedule for the system is shown in figure 3. The top graph in this figure shows the chirped transmission of the oblique sounder transmitter. A complete sweep from 2 MHz to 16 MHz takes 4 minutes and 40 seconds (280 seconds). The bottom graph in figure 3 shows the power transmitted from the ICOM transceiver/amplifier as a function of time during one sweep of the sounder transmitter. One second after the sounder has swept through one of the three measurement frequencies, the ICOM transmits that frequency for 15 seconds. This process repeats every 5 minutes for a total of 288 measurement periods for each frequency per day. The offset start time for the sounder is 0 minutes and 15 seconds.

The heights of the transmit antennas at the Montana site were not adjusted for exact 1/4-wavelength resonance. However, since the initial VSWR for each antenna was less than 2.0 for the selected frequency, the internal tuning network of the ICOM 781 was able to match the transmitter at each frequency for maximum power transfer consequently, the input power to each antenna is 150 watts (51.76 dBm) as measured by the ICOM 781. A BIRD Model 4221 RF Power Meter was used to calibrate the ICOM for this measurement by using a standard 50-ohm load. The total system loss at the Montana transmitter site for each frequency is shown in table 1.

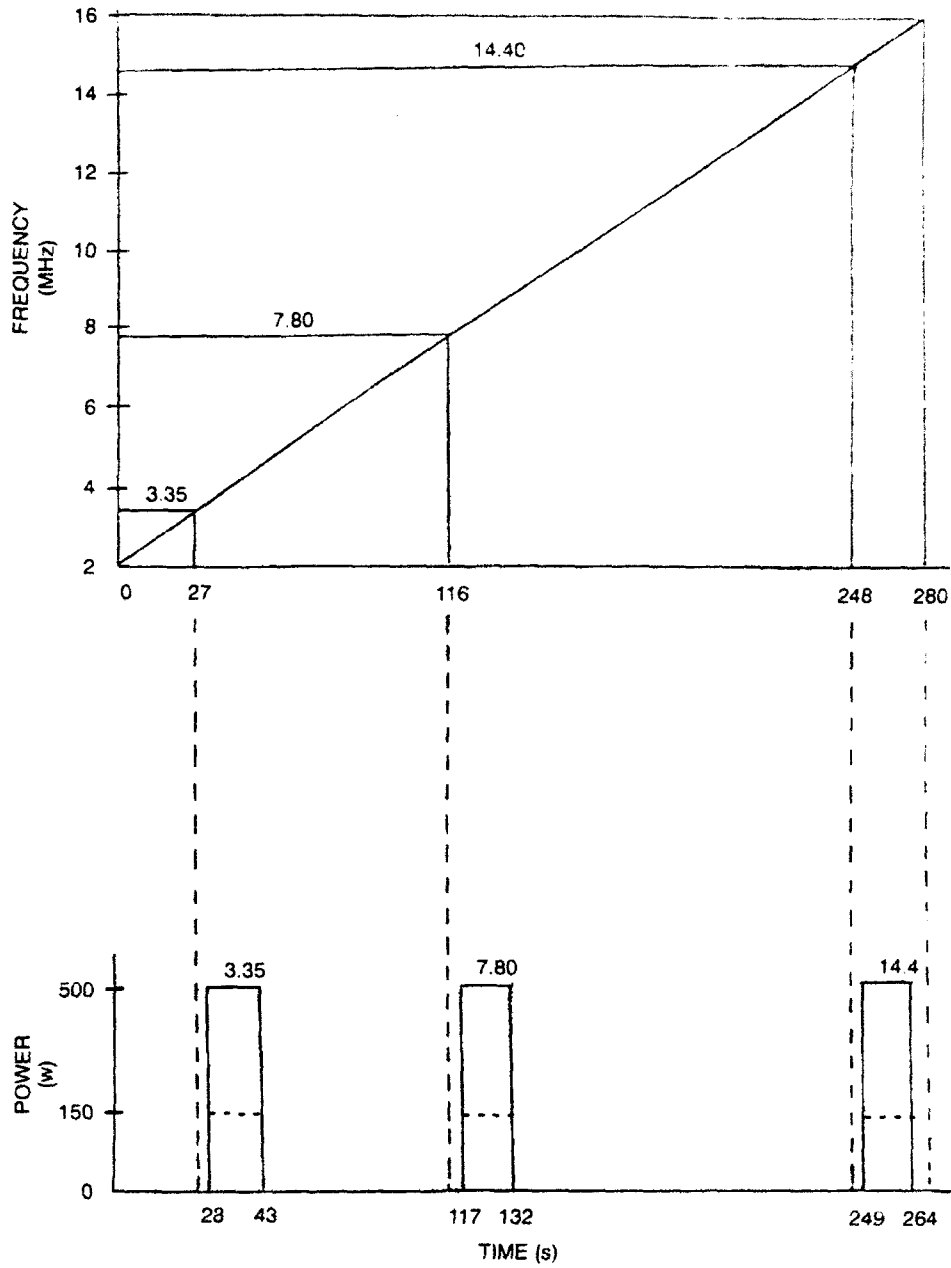

Figure 3. Transmit schedule for received power measurements. Top plot shows linear chirp of sounder transmitter. Bottom plot shows transmission schedule of 150-watt transmitter.

Table 1. Transmitter system losses

Antenna Frequency, MHz	Impedance, ohms	Antenna Match, dB	Cable Length, ft	Cable Loss, dB	Total Loss, dB
3.35	24.6	0.2	158	0.2	0.4
7.8	33.8	0.2	160	0.5	0.7
14.4	32.5	0.2	166	0.8	1.0

RECEIVING SYSTEM

A block diagram of the receiver system, located at the Naval Radio Receiving Facility in Imperial Beach, California, is shown in figure 4. The antenna configuration at the receive site matches that at the transmission site, with one 1/4-wavelength vertical monopole antenna for each of the three transmission frequencies, and a 32-foot vertical antenna for the chirp sounder receiver.

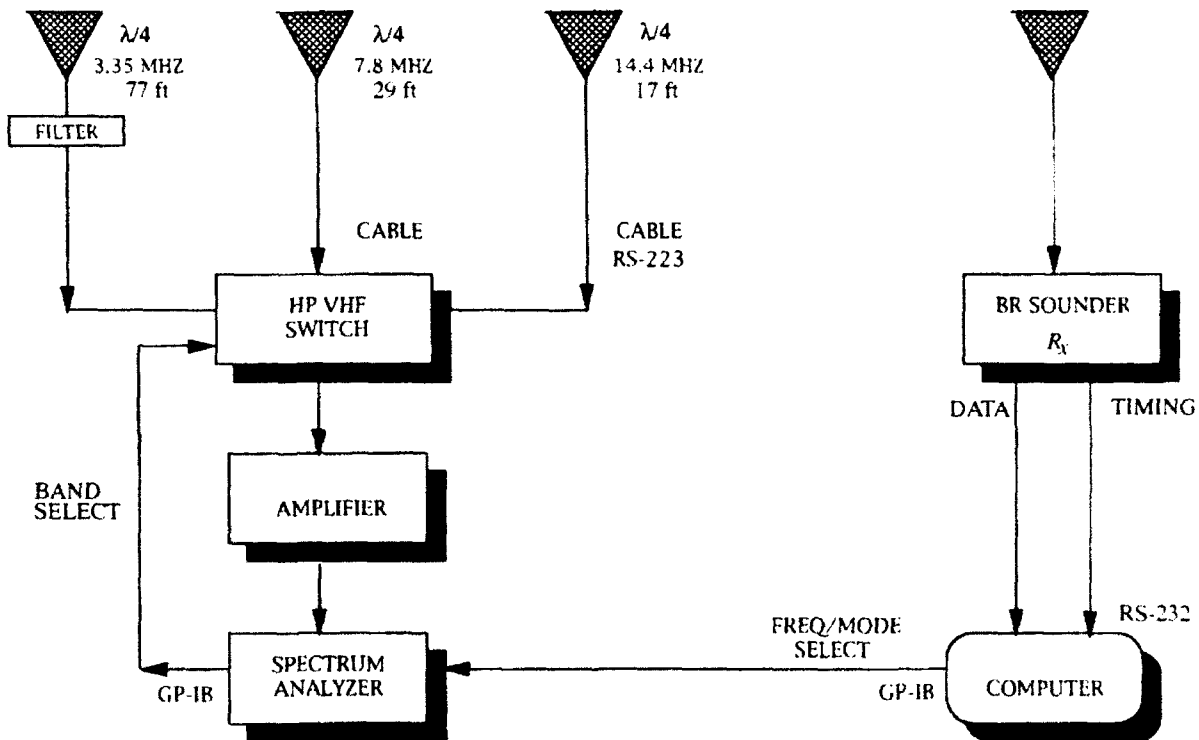

Figure 4. Receiver system.

The 1/4-wavelength antennas are each erected over a ground plane consisting of 50 1/4-wavelength-long ground wires which are equally spaced in a radial pattern around the antenna base. The relative dielectric constant of the ground at the Imperial Beach site is estimated to be approximately 10, and the conductivity is approximately 0.002 mho/m.

Each antenna is connected to an HP VHF antenna switch via RG-223 double-shielded coaxial cable. The 3.35-MHz antenna also has a narrowband filter between the antenna and the HP VHF switch to remove some of the low-frequency man-made noise observed at the site. The output of the VHF switch is connected to a pair of preamplifiers (11 dB each, 22 dB total), which are connected to an HP-8566b spectrum analyzer. The preamplifiers are required to boost the external noise to a level that exceeds the internal noise level of the spectrum analyzer. They also act as a 'fuse' to protect the spectrum analyzer from the occasional strong noise bursts observed at the site.

The receiver system is controlled by a GP-IB cable connection between the VHF switch, the spectrum analyzer, and the controlling computer. Timing is provided by an RS-232 cable connection between the computer and the oblique sounder receiver, which maintains synchronization with the sounder transmitter in Montana, as previously described.

At the receiver site, the height of the 7.8-MHz and 14.4-MHz antennas was adjusted to near resonance; however, the size of the 3.35-MHz antenna made adjustment impractical. An HP 8593A network analyzer was used to measure the input impedance as a function of frequency for each antenna. Smith Chart plots, figures 5 through 7, show the results of the measurements for 3.35 MHz, 7.8 MHz, and 14.4 MHz, respectively. The measured impedances are also listed in table 2.

The receiver site mismatch losses were computed using the measured antenna input impedances and the 50-ohm coaxial cable impedance. The loss of the RG-223 double-shielded coaxial cable was computed based on physical cable length for each frequency. The combined losses for each frequency are shown in table 2. Note that the 3.35-MHz antenna also has additional insertion loss from the filter mentioned above.

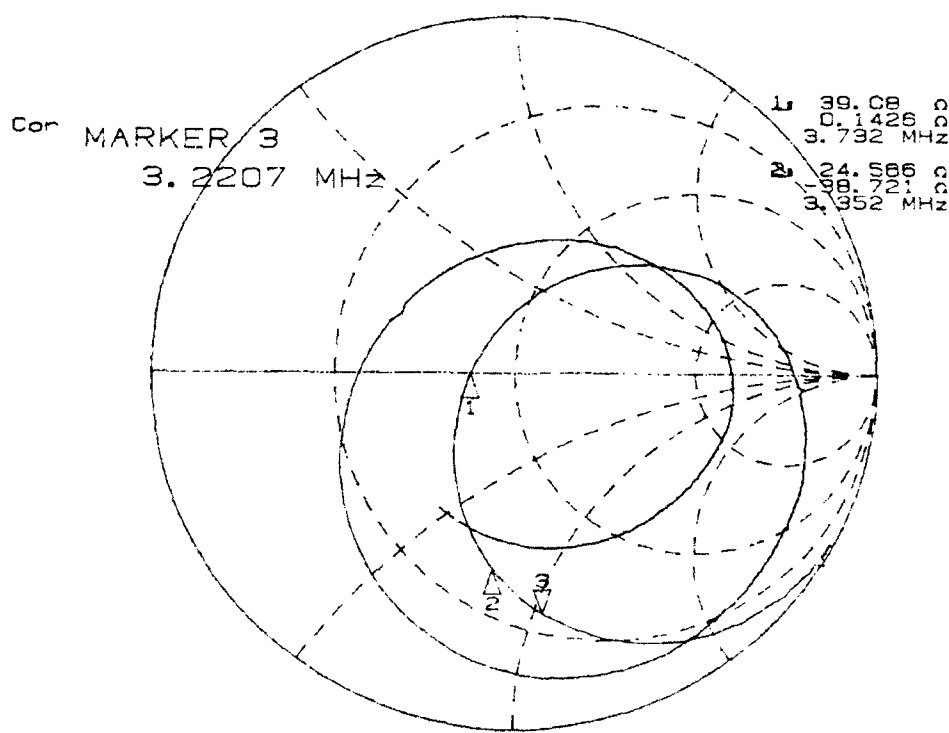

Figure 5. Smith Chart showing input impedance of antenna for 3.35-MHz signal (Marker 2).

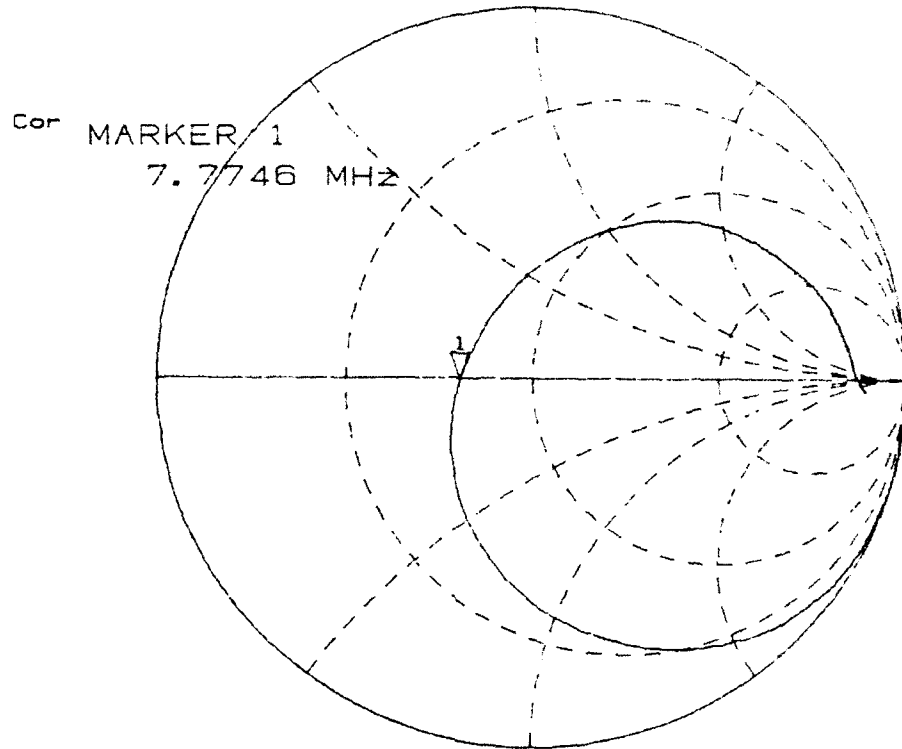

Figure 6. Smith Chart showing input impedance of antenna for 7.8-MHz signal (Marker 1).

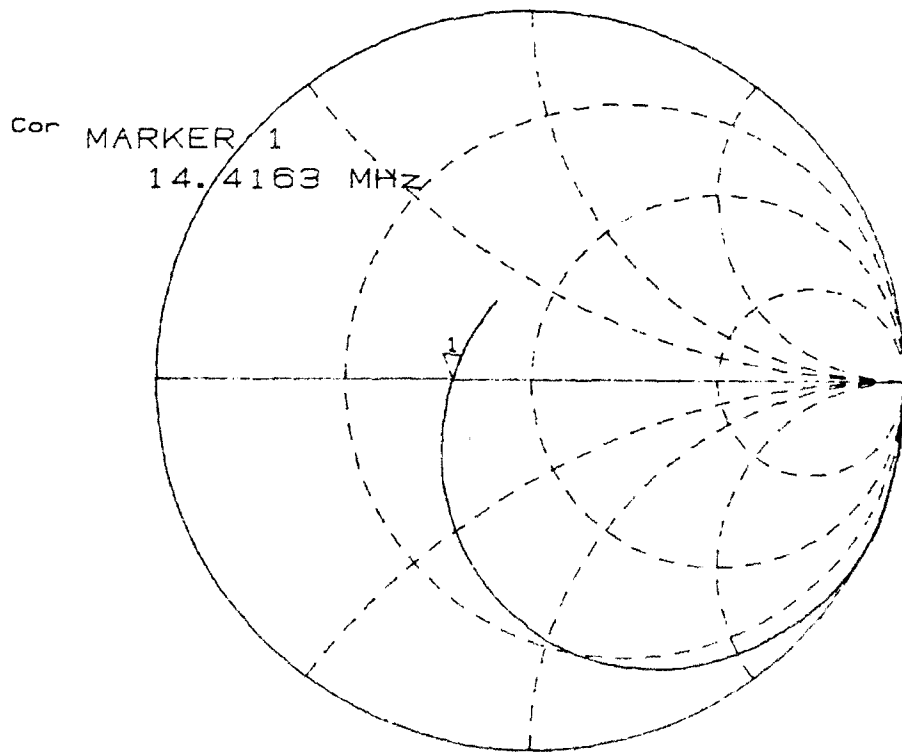

Figure 7. Smith Chart showing input impedance of antenna for 14.4-MHz signal (Marker 1).

Table 2. Receive site antenna and system losses.

Antenna Frequency, MHz	Measured Impedance, ohms	Antenna Match, dB	Cable Length, ft	Cable Loss, dB	Filter Loss, JB	Total Loss, dB
3.35	24.6-i38.7	1.6	147	1.0	3.0	5.5
7.8	33.8+i0.01	0.2	107	1.2	0.0	1.4
14.4	32.5+i0.06	0.2	64	1.0	0.0	1.2

MEASUREMENTS

As mentioned, timing for the measurement system is provided by the oblique sounder system deployed on the circuit. A measurement cycle begins with the start of a sweep on the sounder system. The controlling computer at the transmit site continuously monitors the clock on the oblique sounder transmitter. At the start of a sweep, the computer begins to count seconds until the first of the three frequencies is to be transmitted. One second after the lowest measurement frequency (3.35 MHz) is transmitted by the sounder, the computer remotely tunes the ICOM to that frequency and begins CW transmission of the lowest frequency for 15 seconds. At the end of this period, the computer resets the ICOM to USB mode, effectively stopping transmission. The computer then resumes counting seconds until 1 second after the next transmission frequency (7.8 MHz) is sent. At that time, the ICOM is tuned to the second frequency and CW transmission begins at that frequency for 15 seconds. The computer then resets the ICOM to USB mode and the process is repeated for the final measurement frequency (14.4 MHz). At the end of a sweep, the computer again begins to monitor the sounder clock for the beginning of the next sweep, at which time the process is repeated.

On the receive end, timing is provided by the sounder receiver, which maintains time synchronism with the sounder transmitter to within 1 second. Again, the controlling computer continuously monitors the clock on the sounder receiver until a sweep begins. Fifteen seconds before the lowest measurement frequency is to be transmitted by the ICOM transmitter, the computer remotely selects the antenna for that frequency, tunes the spectrum analyzer to that frequency, and begins to measure the local noise environment. This measurement continues for 30 seconds, the last 15 of which the transmitter in Montana is transmitting on that frequency. At the end of 30 seconds, 1000 data samples are written to a data file on the controlling computer and the computer resumes monitoring the sounder clock. Fifteen seconds before the next frequency is to be transmitted, the antenna for that frequency is selected and the spectrum analyzer begins monitoring at that frequency for 30 seconds. At the end of that period, data are again written to a data file on the computer and the process is repeated for the last frequency. At the end of a sweep, the computer again goes into its clock-monitoring mode until the next sweep begins.

This process is repeated every 5 minutes throughout the day, resulting in 288 data measurement periods each day. The sounder receiver readjusts its sweep start time after each sweep to insure that time synchronism is maintained with the remote transmitter.

At the end of each sweep, the sounder receiver is polled for mode information from that sweep. This information, which consists of the propagating frequency band for each mode

detected on the ionogram, is also written to the data file on the controlling computer. A second sounder receiver which produces printed copies of the entire oblique ionogram is also available for periodic verification of the mode data.

For each 5-minute period, the data set consists of 15 seconds of measured noise power, followed by 15 seconds of measured (signal plus noise) power, at each of the three frequencies. In addition, the propagating mode structure for each frequency (taken 1 second before the data measurement) is available for each frequency.

DATA SAMPLES

Figures 8 through 13 provide examples of the measured data. Figures 8 through 10 show the received power at each frequency for the sweep, which began at 00:20:15 PST, on January 1, 1994. Figures 11 through 13 show similar data for the sweep, which began at 12:00:15 PST, on the same day. Both sets of plots show received power in dBm (decibels relative to a milliwatt). Data shown in all figures in this section were obtained when the 500-watt amplifier was still in use at the Montana transmitting site. As explained previously, this amplifier has since been removed from the transmission system.

Figures 8 and 9 clearly show the effect of the transmitted signal on received power for 3.35 MHz and 7.8 MHz. In each case, the received power increases by approximately 30 dBm when the Montana site begins transmission. Figure 10 shows that very little signal is received at 14.4 MHz. This is to be expected since these data were obtained shortly after local midnight when the ionosphere is depleted and cannot support propagation at the higher frequency.

Figures 11 through 13 show examples of data collected near local noon, and the opposite frequency effects are noted. In this case, the lowest frequency signal, shown in figure 11, is almost completely absorbed in the lower ionosphere and the resulting received power is extremely low. Figure 12 shows that a signal of over 30 dBm is received at 7.8 MHz. At the highest frequency, figure 13 shows a very strong signal, approximately 50 dBm.

It should be stressed that the data examples shown in figures 8 through 13 have not been corrected for the gains and losses introduced by the transmitting and receiving systems as detailed above. These figures simply show the raw received data as observed on the spectrum analyzer.

The oblique ionograms taken during the measurement periods of the data shown in figures 8 through 13 are shown in figure 14. Figure 14a is the oblique ionogram generated during the sweep which began at 00:20:15 PST on 1 January 1994, corresponding to the data shown in figures 8 through 10. Figure 14b, taken on the same day during the sweep that began at 12:00:15 PST, corresponds to the data of figures 11 through 13.

The data in figure 8 show quasiperiodic fades of 15 dBm throughout the 15 second noise collection period. Assuming that the noise is predominantly locally generated, the fluctuations in the received power in the final 15 seconds are likely due to the same source. However, figure 14a shows that multiple modes were propagating at 3.35 MHz, which may have produced some intermodal fading of the signal during this period.

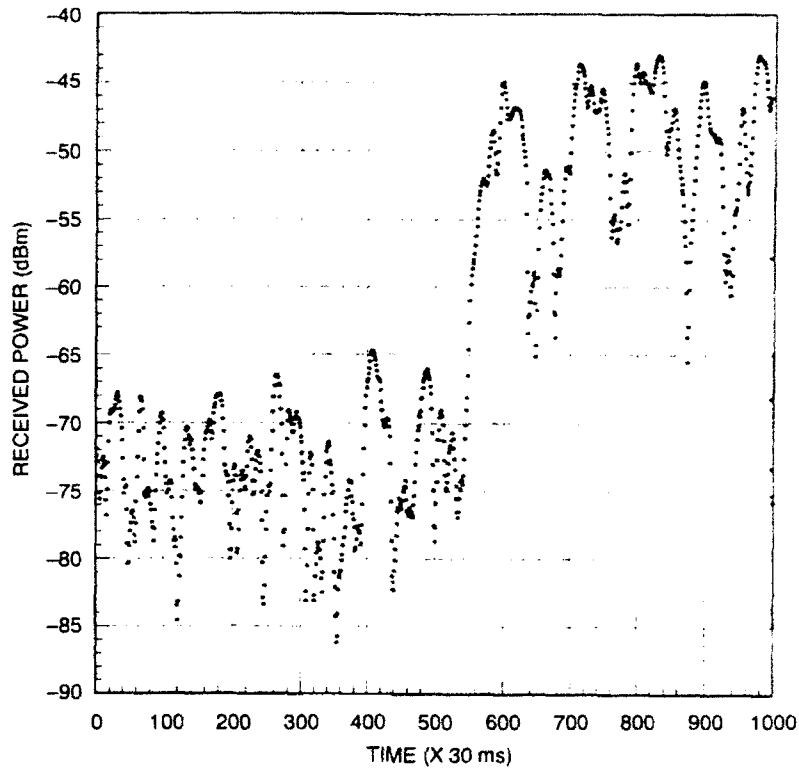

Figure 8. Received power for 3.35 MHz at 00:20:15 PST on 1 January 1994.

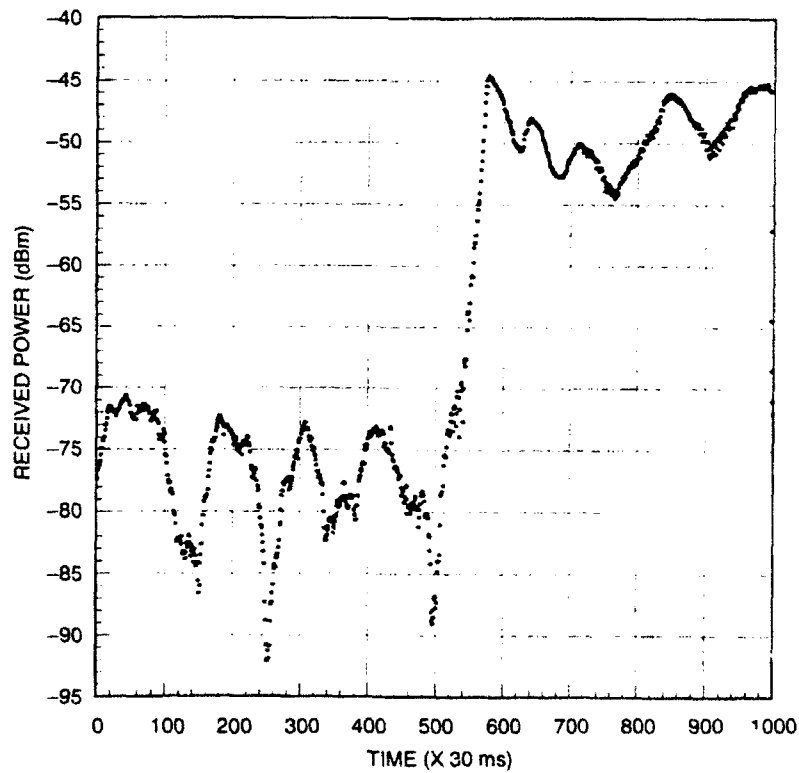

Figure 9. Received power for 7.8 MHz at 00:20:15 PST on 1 January 1994.

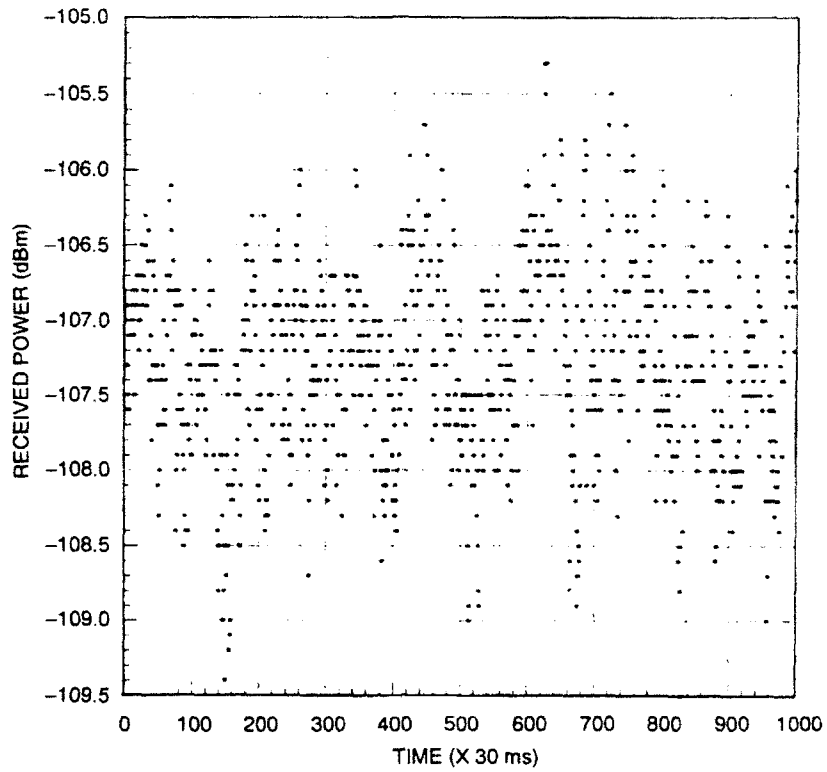

Figure 10. Received power for 14.4 MHz at 00:20:15 PST on 1 January 1994.

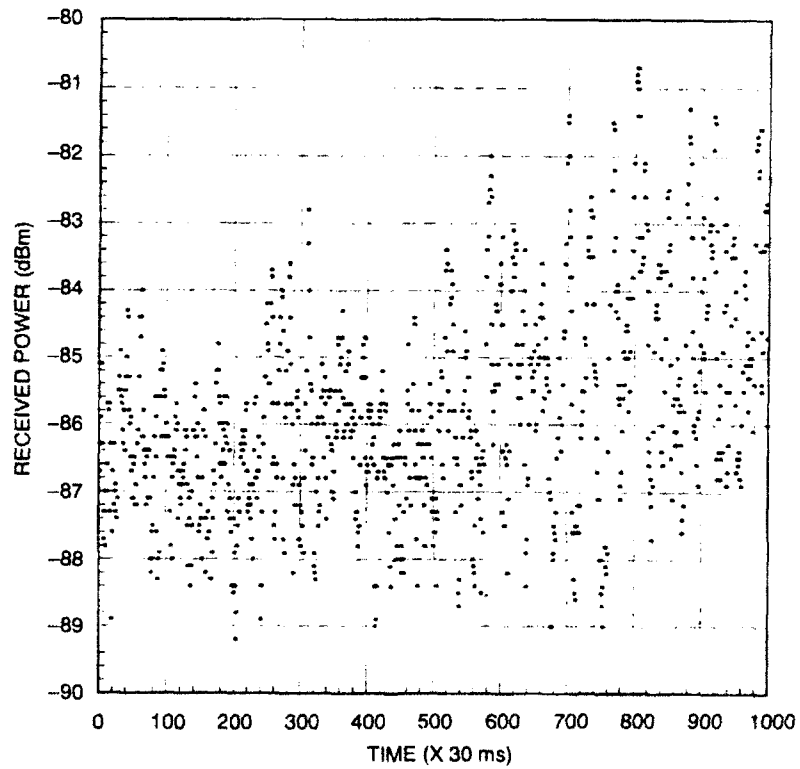

Figure 11. Received power for 3.35 MHz at 12:00:15 PST on 1 January 1994.

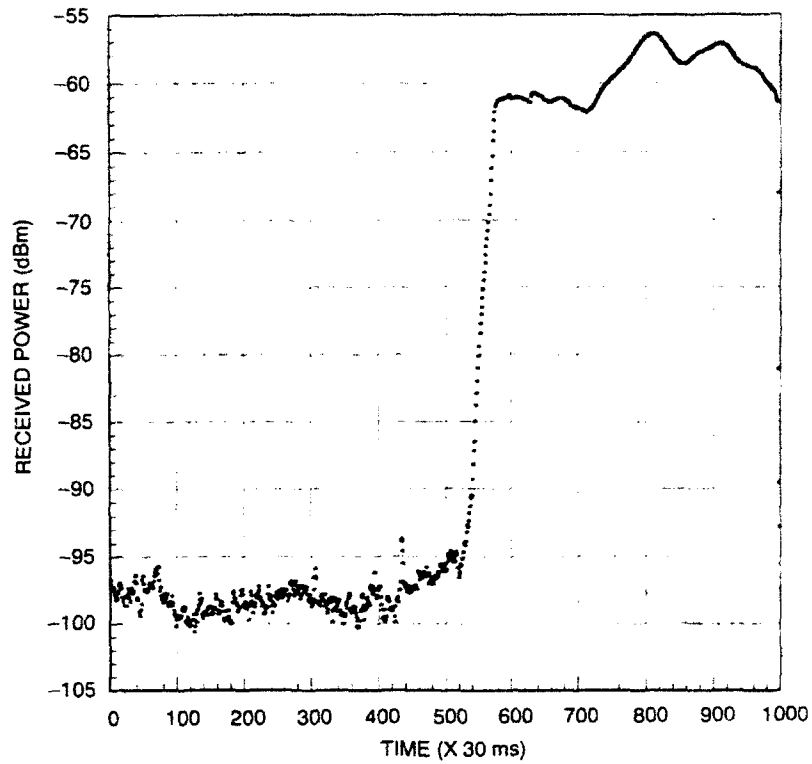

Figure 12. Received power for 7.8 MHz at 12:00:15 PST on 1 January 1994.

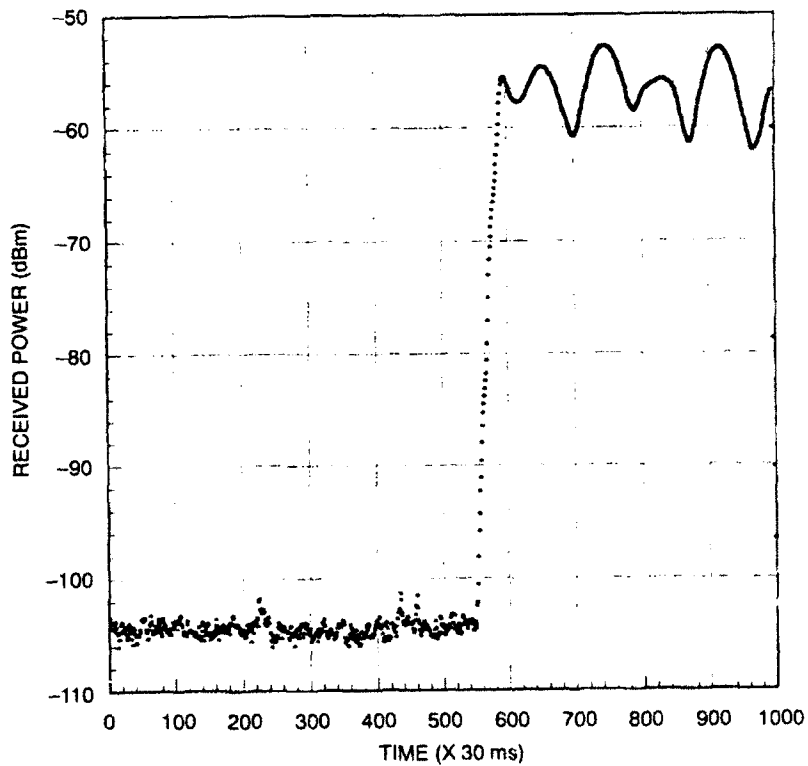
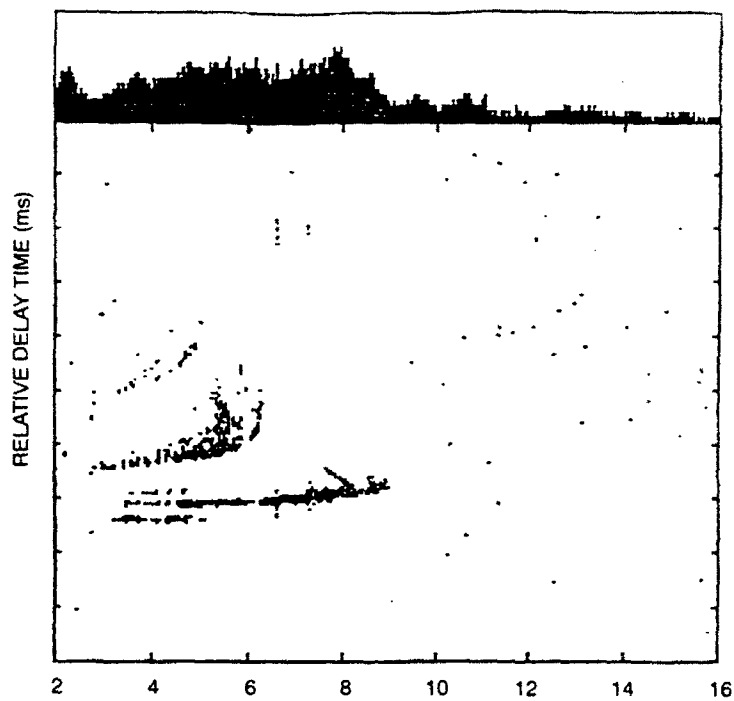
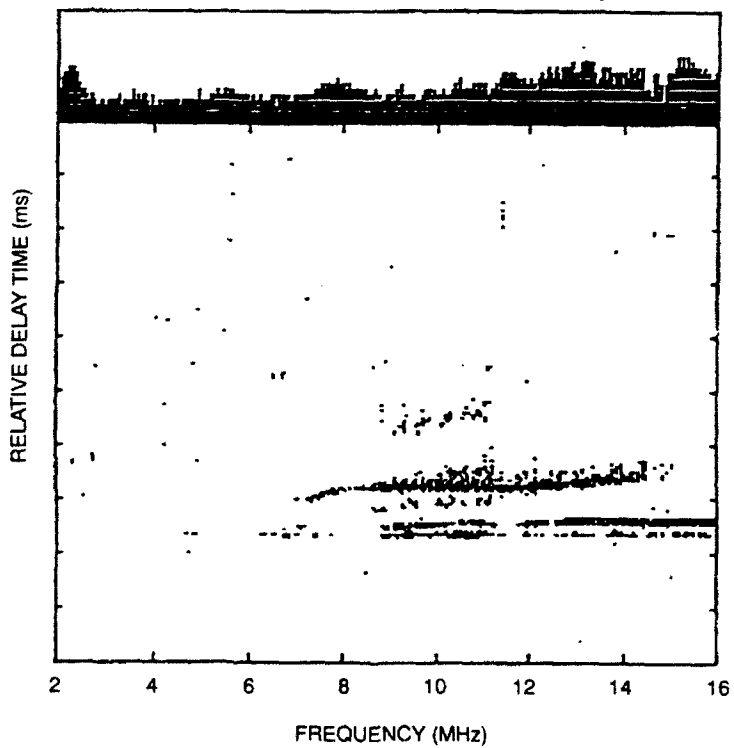

Figure 13. Received power for 14.4 MHz at 12:00:15 PST on 1 January 1994.



(a) Plot taken at 00:20:15 PST on 1 January 1994.



(b) Plot taken at 12:00:15 PST on 1 January 1994.

Figure 14. Oblique ionograms taken during sweeps corresponding to figures 8 through 10 (top) and figures 11 through 13 (bottom).

The fading of the signal in the final 15 seconds shown in figure 9 is somewhat different than that seen in the noise measurements of the first 15 seconds. The noise again shows a quasiperiodic variation, likely due to a local man-made noise source; however, the signal variation seen in the last 15 seconds appears to be related to changes on the propagation path. The ionogram of figure 14a shows that the modal structure at 7.8 MHz was dominated by the one-hop *F*-layer mode, so intermodal interference was probably minimal. The fading shown in the last 15 seconds of figure 9 is likely due to electron density variations along the propagation path that can produce fluctuations in the absorption and polarization of the signal and loss of signal due to scattering.

The reason for the lack of a detectable signal in the last 15 seconds of data shown in figure 10 is made clear by inspecting figure 14a. The maximum usable frequency on the propagation path for this period is approximately 9 MHz; thus, the ionosphere was not capable of supporting propagation at 14.4 MHz.

The received signal power at 3.35 MHz in figure 11 shows very little change between the first and last 15 seconds. Figure 14b shows that no modes at that frequency were detectable by the ionosonde receiver. This is to be expected for such a low frequency during mid-day, when ionospheric absorption is maximum; however, the sensitivity of the spectrum analyzer measuring system is greater than that of the sounder receiver since it has been optimized to receive these three frequencies. Also, the transmitted power level for the sounder system is more than 15 dBm less than for the measurement system. For these reasons, some energy from the Montana transmitter reached the analyzer, causing the slight increase (3–4 dBm) in the final 15 seconds, even though the oblique ionogram did not record a signal at this frequency.

At 7.8 MHz, figure 12 shows a weak noise variation with an apparent period of approximately 9 seconds during the first 15 seconds. The final 15 seconds shows a 5-dBm signal rise approximately 5 seconds into the transmission. The ionogram of figure 14b shows the possible existence of a sporadic-E (*Es*) layer at this frequency. An *Es* layer is a thin layer of increased ionization which forms near 100 km in the ionospheric E-layer. Because the layer is very thin, reflections from such layers usually take place with little absorption in the layer. This may be the cause of the slight increase in received power for this frequency.

Finally, in figure 13, the received power for 14.4 MHz shows little variation in the noise during the first 15 seconds. The oscillations occurring during the final 15 seconds are likely due to modal interference between the *Es* and one-hop *F*₂-layer reflections, which are indicated in figure 14b for this frequency.

The purpose of the previous data plots is to give the reader a feeling for the level of variation of received power which is typical for the mid-latitude ionosphere over time scales of 15 seconds. To see variations on longer time scales (days), median values of the noise and signal plus noise have been determined for each 5-minute period, at each frequency, for several consecutive days. These median values are shown in figures 15 through 20.

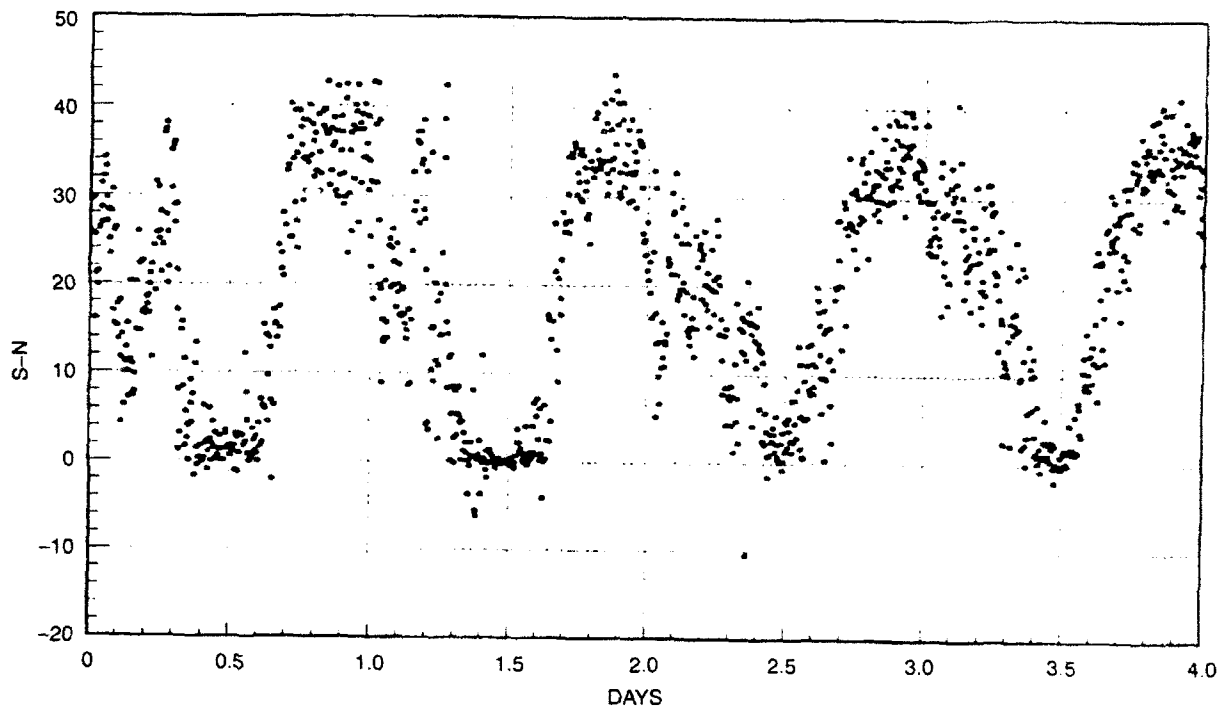

Figure 15. Median signal-to-noise ratios at 3.35 MHz from 29 December 1993 to 1 January 1994.

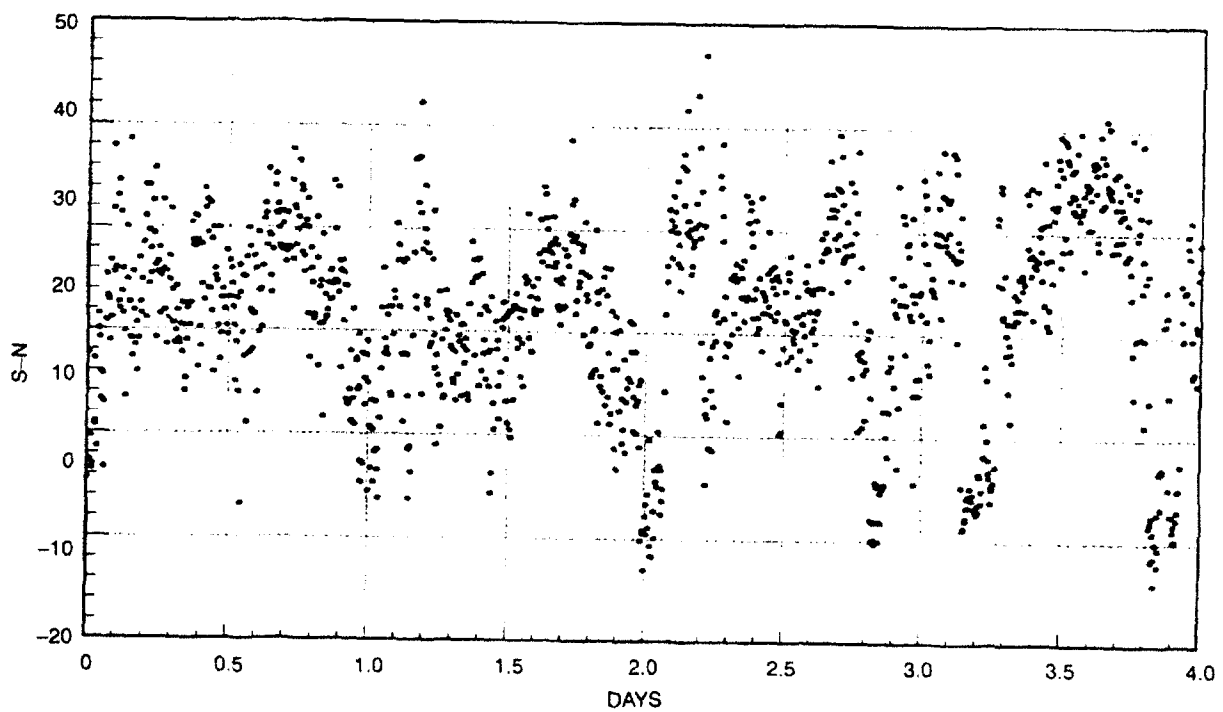

Figure 16. Median signal-to-noise ratios at 7.8 MHz from 29 December 1993 to 1 January 1994.

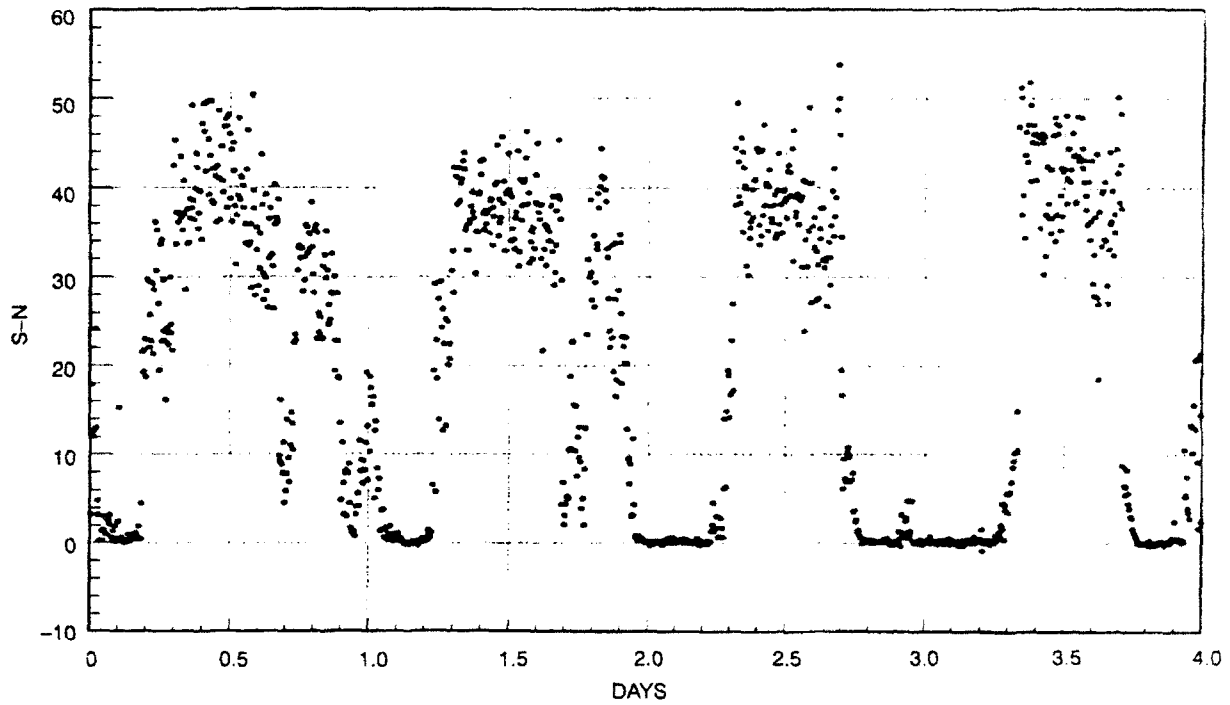

Figure 17. Median signal-to-noise ratios at 14.4 MHz from 29 December 1993 to 1 January 1994.

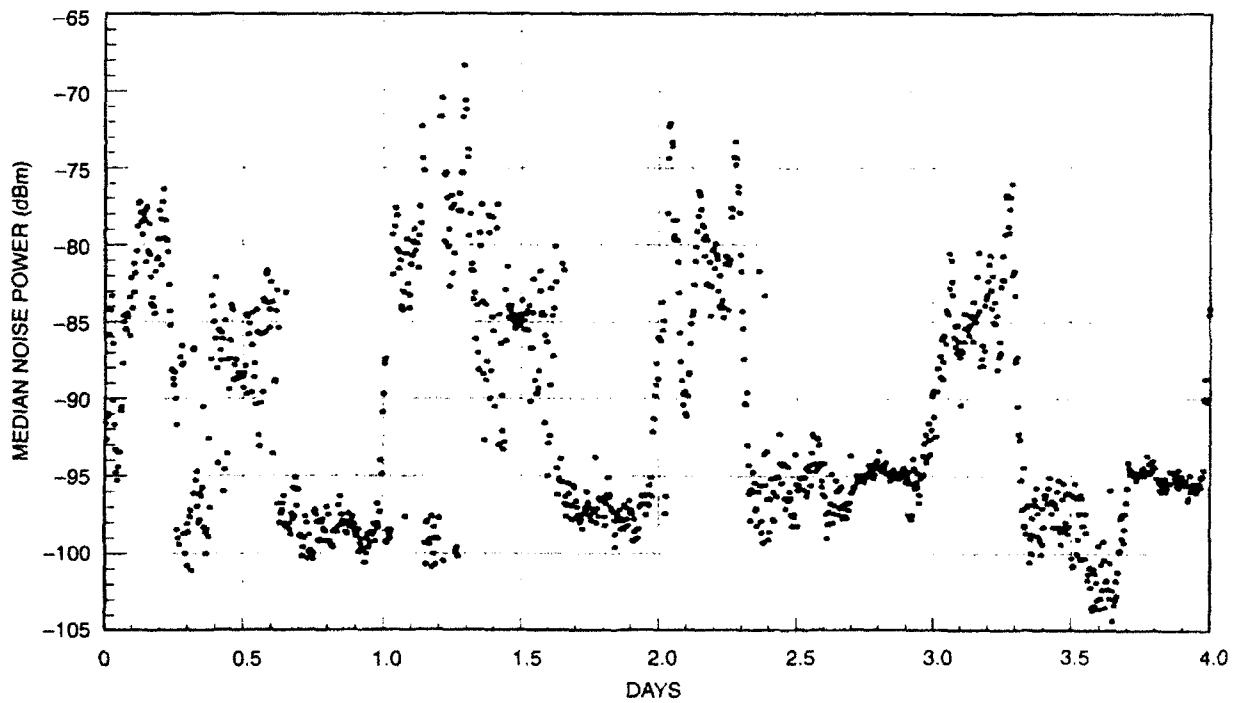

Figure 18. Median noise power at 3.35 MHz from 29 December 1993 to 1 January 1994.

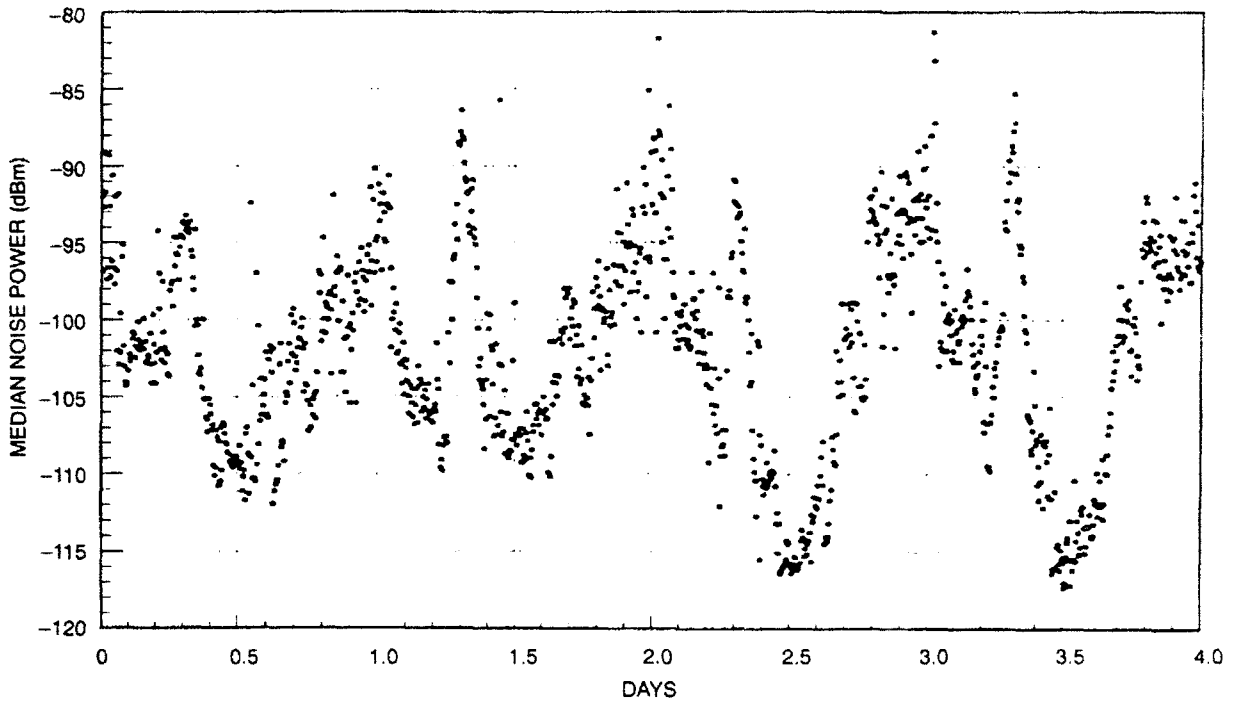

Figure 19. Median noise power at 7.8 MHz from 29 December 1993 to 1 January 1994.

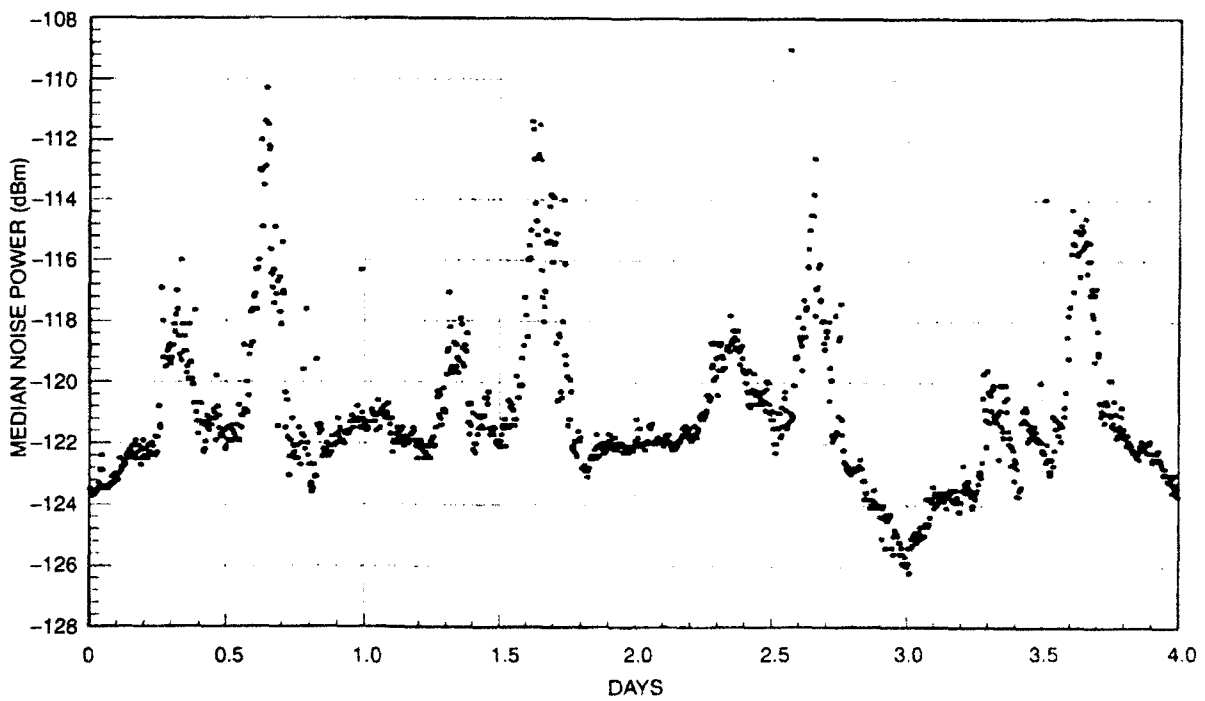

Figure 20. Median noise power at 14.4 MHz from 29 December 1993 to 1 January 1994.

Figures 15 through 17 show median signal-to-noise ratios for the three frequencies from 29 December 1993 through 1 January 1994. Data for these figures were obtained by determining the median noise power for the first 15 seconds of each measurement period and by subtracting that value from the signal-plus-noise power measured during the final 15 seconds when the Montana transmitter was active. In practice, only the middle 12 seconds of noise and signal-plus-noise data were used to determine the median values. Figures 8 through 13 show that it takes some time for the ICOM amplifier to reach a full 500-watt signal strength and to relax back to zero power transmitted at the end of the 15-second cycle. To avoid including this transition data in the analysis, only the middle segments of data were used to determine median values.

Figure 15 shows median signal-to-noise ratios for 3.35 MHz for the four consecutive days. Clearly visible is the expected diurnal variation. Signal strength peaks during the nighttime and drops to noise level at mid-day.

Figure 16 shows median signal-to-noise ratios for 7.8 MHz for the four consecutive days. In this case, the signal is generally maintained at a level which exceeds the noise level at all times. This frequency was chosen because it was hoped that it would propagate by some mode at most hours of the day. That this is the case is evident in figure 16.

Signal-to-noise ratios on the 14.4-MHz signal for the four days are shown in figure 17. Here the diurnal variation is again evident. Propagation is good during mid-day, with typical values of 40 dBm; however, at night the signal will not propagate and the signal level falls to zero.

Figures 18 through 20 show the median noise power, corrected for the losses and gains at the receive site, at each frequency for the same four days used in figures 11 through 13. The median noise at 3.35 MHz is shown in figure 18. Noise levels at this frequency rise sharply at midnight each day and maintain a high level till near sunrise. Noise levels are typically low at midday. This gross behavior can be understood by the same reasoning as that regarding daytime absorption at low frequencies. It is clear from figure 18 that there is considerable local interference at the Imperial Beach site at this frequency.

The median noise at 7.8 MHz, shown in figure 19, has a similar diurnal behavior as that for 3.35 MHz. Noise at this frequency also peaks during the nighttime; however, the increase begins much earlier in the night than the 3.35-MHz noise. A secondary peak in the early morning is probably produced by a local man-made source.

The median noise at 14.4 MHz is shown in figure 20. In this case, man-made noise dominates and maintains approximately the same level throughout the day. Clearly visible in this plot is the existence of a strong local source which appears symmetrically around local noon each day.

CONCLUSION

This report describes the HF signal power measurement system that has been implemented on the Montana to California propagation path. Measurement of HF signals began in late December 1993. In January 1994 a major hardware failure caused the shutdown of the system until repairs could be completed in March 1994. Since that time, however, data collection has been relatively continuous, with only periodic hardware failure or power outages at the Montana site.

Data collected from the measurement system are currently being reduced for the extraction of parameters for comparison to existing propagation models. A report describing the data preparation methods and results of the comparison to models is in preparation.

REPORT DOCUMENTATION PAGE

Form Approved
OMB No. 0704-0188

Public reporting burden for this collection of information is estimated to average 1 hour per response, including the time for reviewing instructions, searching existing data sources, gathering and maintaining the data needed, and completing and reviewing the collection of information. Send comments regarding this burden estimate or any other aspect of this collection of information, including suggestions for reducing this burden, to Washington Headquarters Services, Directorate for Information Operations and Reports, 1215 Jefferson Davis Highway, Suite 1204, Arlington, VA 22202-4302, and to the Office of Management and Budget, Paperwork Reduction Project (0704-0188), Washington, DC 20503.

1. AGENCY USE ONLY (Leave blank)		2. REPORT DATE <p style="text-align: center;">July 1994</p>	3. REPORT TYPE AND DATES COVERED <p style="text-align: center;">Preliminary: Oct 1993-July 1994</p>
4. TITLE AND SUBTITLE <p style="text-align: center;">HIGH-FREQUENCY SKYWAVE SIGNAL POWER MEASUREMENT SYSTEM</p>		5. FUNDING NUMBERS <p style="text-align: center;">PE: 0602435N WU: DN30221</p>	
6. AUTHOR(S) Richard Sprague and William Moison, <i>NRaD</i> . John Theisen, <i>Science and Technology Corp.</i>		8. PERFORMING ORGANIZATION REPORT NUMBER <p style="text-align: center;">TD 2664</p>	
7. PERFORMING ORGANIZATION NAME(S) AND ADDRESS(ES) Naval Command, Control and Ocean Surveillance Center (NCCOSC) RDT&E Division San Diego, CA 92152-5000		10. SPONSORING MONITORING AGENCY REPORT NUMBER	
9. SPONSORING/MONITORING AGENCY NAME(S) AND ADDRESS(ES) Office of Naval Research 800 N. Quincy St. Arlington, VA 22217-5000		11. SUPPLEMENTARY NOTES	
12a. DISTRIBUTION/AVAILABILITY STATEMENT <p style="text-align: center;">Approved for public release; distribution is unlimited.</p>		12b. DISTRIBUTION CODE	
13. ABSTRACT (Maximum 200 words) <p style="text-align: center;">This report describes the high-frequency received power measurement system which was recently deployed on a transmission circuit between Montana and California. Transmitter and receiver systems are described, and examples of the measured data are given.</p>			
14. SUBJECT TERMS HF field strength measurements radio propagation		15. NUMBER OF PAGES <p style="text-align: center;">29</p>	
		16. PRICE CODE	
17. SECURITY CLASSIFICATION OF REPORT <p style="text-align: center;">UNCLASSIFIED</p>	18. SECURITY CLASSIFICATION OF THIS PAGE <p style="text-align: center;">UNCLASSIFIED</p>	19. SECURITY CLASSIFICATION OF ABSTRACT <p style="text-align: center;">UNCLASSIFIED</p>	20. LIMITATION OF ABSTRACT <p style="text-align: center;">SAME AS REPORT</p>

UNCLASSIFIED

21a NAME OF RESPONSIBLE INDIVIDUAL Richard Sprague	21b TELEPHONE <i>include Area Code</i> (619) 553-3064	21c OFFICE SYMBOL Code 542

INITIAL DISTRIBUTION

Code 0012	Patent Counsel	(1)
Code 0274	Library	(2)
Code 0275	Archive/Stock	(6)
Code 50	H. O. Porter	(1)
Code 54	J. H. Richter	(1)
Code 542	J. A. Ferguson	(1)
Code 542	R. A. Sprague	(10)
Code 542	W. K. Moision	(10)

Defense Technical Information Center
Alexandria, VA 22304-6145 (4)

NCCOSC Washington Liaison Office
Washington, DC 20363-5100

Center for Naval Analyses
Alexandria, VA 22302-0268

Navy Acquisition, Research and Development
Information Center (NARDIC)
Arlington, VA 22244-5114

GIDEP Operations Center
Corona, CA 91718-8000

Naval Radio Receiving Facility
Imperial Beach, CA 91933 (2)

Air Force Vananda Radar Site
Forsyth, MT 59321-5026 (2)