

CECOM-TR-91-J258-F

AD-A284 454



COMPREHENSIVE STUDY OF DIODE-PUMPED DYE LASERS

Mr. David Benfey
Dr. David Brown

Laser Technology Associates, Inc.
25 Ozalid Road
Johnson City, NY 13790

Final Report

July 26, 1991

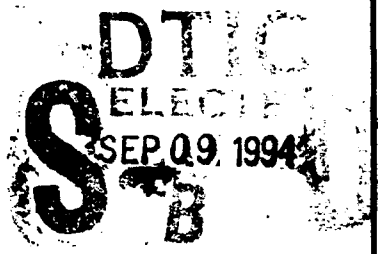

NIGHT VISION & ELECTRONIC SENSORS DIRECTORATE
(NVESD)
AMSEL-RD-NV-SE-EOIR
FORT MONMOUTH, NJ 07703-5206

US Army Contract #DAAB07-91-C-J258

Period Covered June 1 through July 26, 1991

APPROVED FOR PUBLIC RELEASE;
DISTRIBUTION IS UNLIMITED.

94-29501

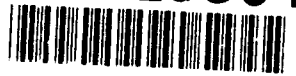

2/28

DTIC QUALITY ASSURED

COMMUNICATIONS-ELECTRONICS COMMAND (CECOM)
FORT MONMOUTH, NJ 07703-5206

NOTICES

Disclaimers

The findings in this report are not to be construed as an official Department of the Army position, unless so designated by other authorized documents.

The citation of trade names and names of manufacturers in this report is not to be construed as official Government endorsement or approval of commercial products or services referenced herein.

DTIC QUALITY ASSURANCE

REPORT DOCUMENTATION PAGEForm Approved
OMB No. 0704-0188

Public reporting burden for this collection of information is estimated to average 1 hour per response, including the time for reviewing instructions, searching existing data sources, gathering and maintaining the data needed, and completing and reviewing the collection of information. Send comments regarding this burden estimate or any other aspect of this collection of information, including suggestions for reducing this burden, to Washington Headquarters Services, Directorate for Information Operations and Reports, 1215 Jefferson Davis Highway, Suite 1204, Arlington, VA 22202-4302, and to the Office of Management and Budget, Paperwork Reduction Project (0704-0188), Washington, DC 20503.

1. AGENCY USE ONLY (Leave blank)		2. REPORT DATE July 1991	3. REPORT TYPE AND DATES COVERED Final Report: 1 Jun to 26 Jul 91	
4. TITLE AND SUBTITLE COMPREHENSIVE STUDY OF DIODE-PUMPED DYE LASERS			5. FUNDING NUMBERS C: DAAB07-91-C-J258	
6. AUTHOR(S) David Benfey, David Brown				
7. PERFORMING ORGANIZATION NAME(S) AND ADDRESS(ES) Laser Technology Associates, Inc. 25 Ozalid Road Johnson City, NY 13790			8. PERFORMING ORGANIZATION REPORT NUMBER	
9. SPONSORING/MONITORING AGENCY NAME(S) AND ADDRESS(ES) US Army Communications-Electronics Command (CECOM) Night Vision and Electronic Sensors Directorate ATTN: AMSEL-RD-NV-SE-EOIR (C. Pearce) Fort Monmouth, NJ 07703-5206			10. SPONSORING/MONITORING AGENCY REPORT NUMBER CECOM-TR-91-J258-F	
11. SUPPLEMENTARY NOTES SBIR Phase I Report				
12a. DISTRIBUTION/AVAILABILITY STATEMENT Approved for public release; distribution is unlimited.			12b. DISTRIBUTION CODE	
13. ABSTRACT (Maximum 200 words) This report covers progress since the second periodic report of May 31, 1991 through completion. Previously in this program, two laser dyes were selected as candidates for diode pumping. These were a visible dye, LD-800, and a near infrared (NIR) dye, IR-26. Under a subcontract to Physical Sciences, Inc. (PSI), these two dyes were characterized to provide critical parameters necessary for laser design/optimization. Having completed these characterization experiments, we have achieved Technical Objective 3 of the proposed program, having analyzed and optimized the design of the two dye lasers. These analyses are presented in detail in this report. To summarize our results, it appears quite feasible to produce both CW and pulsed diode-pumped dye lasers using currently available components and technology.				
14. SUBJECT TERMS Dye lasers; diode-pumped lasers; CW lasers; LD-800 dye; IR-26 dye			15. NUMBER OF PAGES 32	
			16. PRICE CODE	
17. SECURITY CLASSIFICATION OF REPORT Unclassified	18. SECURITY CLASSIFICATION OF THIS PAGE Unclassified	19. SECURITY CLASSIFICATION OF ABSTRACT Unclassified	20. LIMITATION OF ABSTRACT UL	



Laser Technology Associates, Inc.

25 Ozalid Road • Johnson City • N.Y. • 13790 • (607) 798-9064 • FAX (607) 798-9911

*M...
8/15/91*

Laser Technology Associates, Inc.
25 Ozalid Road
Johnson City, New York 13790

U.S. Army Contract #DAAB07-91-C-J258
July 26, 1991

Comprehensive Study of Diode-Pumped Dye Lasers

Final Report
Period Covered: June 1 through July 26, 1991

Persons Preparing Report: **Mr. David Benfey**
Dr. David Brown

Person Submitting Report: **Mr. David Benfey**

Accession For	
NTIS GRA&I	<input checked="" type="checkbox"/>
DTIC TAB	<input type="checkbox"/>
Unannounced	<input type="checkbox"/>
Justification	
By _____	
Distribution/ _____	
Availability Codes	
Dist	Avail and/or Special
A-1	

The views, opinions, and/or findings contained in this report are those of the author(s) and should not be construed as an Official Department of the Army position, policy, or decision, unless designated by other documentation. The contractor, Laser Technology Associates, Inc., certifies that, to the best of its knowledge and belief, the technical data delivered here-with under Contract Number DAAB07-91-C-J258 is complete, accurate, and complies with all requirements of the contract.

8/14/91
Date

Mr. David Benfey, Vice President, Laser Systems

Abstract

In this Final Report, we describe progress made on our Phase I Small Business Innovation Research (SBIR) project entitled "Comprehensive Study of Diode Pumped Dye Lasers." This report covers progress since our second periodic report of May 31, 1991 through completion. Previously in this program, two laser dyes were selected as candidates for diode pumping. These were a visible dye, LD-800, and a near infrared (NIR) dye, IR-26. Under a sub-contract to Physical Sciences, Inc. (PSI), these two dye were characterized to provide critical parameters necessary for laser design/optimization. Having com-

pleted these characterization experiments, we have achieved Technical Objective 3 of the proposed program, having analyzed and optimized the design of the two dye lasers. These analyses are presented in detail in this report. To summarize our results, it appears quite feasible to produce both CW and pulsed diode-pumped dye lasers using currently available components and technology. The design concepts conceived in this Phase I SBIR project are proposed to be demonstrated in a follow-on Phase II SBIR contract.

I. Introduction

Organic dye lasers are widely used for scientific, commercial, and military applications, including remote sensing, laser spectroscopy, laser isotope separation, and countermeasure lasers. All present commercial and military dye lasers have the common feature that they are notoriously inefficient, primarily since all such dye lasers are optically-pumped by an inefficient source laser (Q-switched Nd:YAG, argon-ion, copper-vapor, nitrogen, or excimer). While the recent emergence of diode-pumped Nd:YAG lasers will significantly increase the efficiency of doubled Nd:YAG pumped dye laser systems, such systems will nevertheless remain complicated and bulky.

In recent years, there have become available an increasing variety of semiconductor diode lasers. Indeed, as each year passes new records for the output power of diode single emitters are reported and one and two dimensional arrays of diode lasers are becoming increasingly common. An important recent trend is that diode lasers operating at shorter and shorter wavelengths are becoming commercially available. That technology is being driven by the need for short wavelength diodes for the compact and optical disk markets. Red diodes with wavelengths as short as 630 nm are now commercially available.

As reported in our Phase I proposal submitted to the U.S. Army CECOM in response to the 1990 DOD SBIR Solicitation (Topic A90-250) entitled "Comprehensive Study of Diode-Pumped Dye Lasers," the potential marriage of dye laser and diode laser technology has a number of significant advantages, among them:

- Diode lasers have been reported with efficiencies as high as 45%. Broad bandwidth diode-pumped dye lasers (DPDL) could, in principle,

be developed with a wallplug efficiency in the vicinity of 24%. The primary advantage of this in most applications is that compact, lightweight, efficient dye lasers result.

- Organic dyes have very broad absorption features, thus the normally stringent requirements on diode bandwidth and temperature control characteristics, typically associated with diode-pumped Nd:YAG lasers, are considerably relaxed. It is likely that complicated, bulky, and power intensive temperature control systems can be all but eliminated with DPDL systems.
- The wide availability of diode lasers with different operating wavelengths means that efficient operation across the entire visible and near-infrared will be achievable in the near future, as shorter and shorter wavelength diode lasers become available.
- A dye/diode system can be chosen such that absorption at the peak or at any other wavelength within the dye absorption band can be achieved, resulting in another tool for the laser designer - the ability to change the dye cell thickness and dye concentration at will.
- Simple tunable lasers will result, eliminating much of the complexity found in present-day optically-pumped dye laser systems.

To explore the potential efficiency advantage of DPDL's, in Table 1 we compare the system to two commonly used dye laser systems. The first system shown in Table 1, the pulsed Q-switched, flashlamp-pumped, doubled Nd:YAG laser, operates with a typical wallplug efficiency of only about 1%. Frequency doubling reduces the efficiency to about 0.5%. Conversion efficiency from green to dye laser output typically varies from 20-60%, depending

Table 1. Comparison of Common Dye Laser Systems with Diode-Pumped Dye Laser

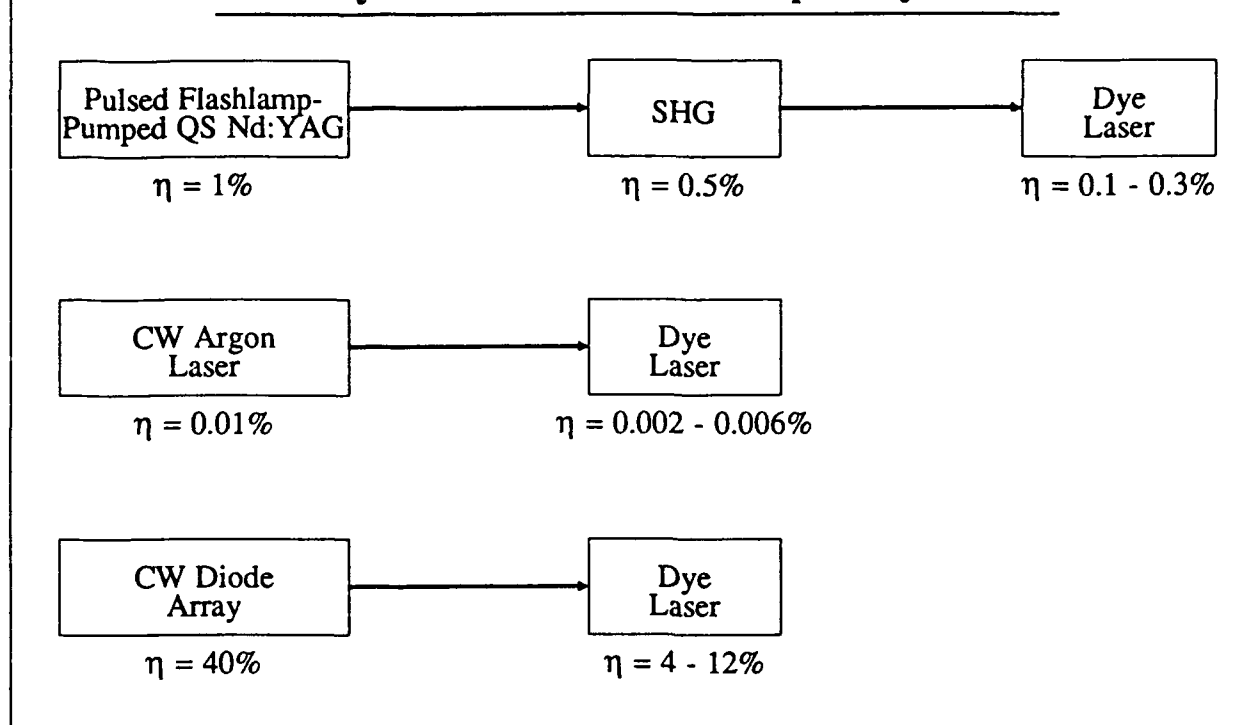

upon the bandwidth, operating wavelength, and pumping configuration. Thus present commercially available dye laser systems have an efficiency in the range of 0.1-0.3%. With the advent of diode-pumped Nd:YAG lasers, however, it is likely that the wallplug efficiency will fall in the range of 0.3-1.5%.

The second system shown in Table 1 is the argon-ion laser pumped dye laser. The typical wallplug efficiency of an argon-ion laser is about 0.01%. The resulting dye laser system then has a wallplug efficiency in the range of 0.002-0.006%, again depending upon the bandwidth and pumping configuration.

In contrast to both of the aforementioned dye laser systems, we show in Table 1 a DPDL that utilizes efficient semiconductor diodes or diode-arrays. Diode-arrays are now available with a typical wallplug efficiency of 40%. Assuming that the array can be efficiently coupled into the dye laser medium, the efficiency of the resulting dye laser system is in the range of 4-12%, a dramatic increase over the Nd:YAG and argon-ion based dye laser systems. Due to the homogeneous nature of the organic dye laser and its broad absorption features, it is likely that the device will be minimally sensitive to the operating temperature of the diode-array, eliminating the need for active cooling. The wallplug efficiency

of diode-pumped Nd:YAG lasers is typically halved due to the need to keep the diode emission wavelength within the Nd:YAG absorption band at 808 nm. The typical diode-array wavelength change with temperature is 0.15-0.25 nm/°C.

It can be seen from the comparison in Table 1 that a tenfold increase in the efficiency of dye lasers can be achieved by using a diode-array source for optical pumping. The (dramatic) consequences of this are that compact, lightweight, dye lasers can be developed that consume a minimum of electrical power.

To further refine our DPDL concept in this U.S. Army Phase I SBIR project, our study approach has been divided into three sections or Technical Objectives. The first two objectives were completed prior to our first Progress Report (March 25, 1991).

The first Technical Objective consisted of surveying and identifying applicable commercially available laser dyes operating at wavelengths suitable for pumping by laser diodes. Likewise, a similar survey of commercially available laser diodes, capable of pumping such dyes, was performed. As a result of this investigation, we chose two dyes which appeared promising for an efficient diode pumped dye laser (DPDL) system.

The second Technical Objective consisted of analyzing laser pump/operation methods in terms of

efficiency and system complexity. It was determined in this task that, at least for the near term, CW operation is most feasible. This is because laser dyes have such short fluorescence lifetimes, on the order of nanoseconds, that a substantial (and costly) number of laser diodes are needed to achieve pulsed operation.

We have decided upon an approach that will initially utilize a flowing dye jet configuration to eliminate thermal effects, intrasystem crossing losses, and dye burning associated with optical windows. This is shown in Figure 1. The jet is placed at Brewster angle to eliminate reflective losses, and at the minimum waist associated with a spherical cavity. An advantage of a CW dye-laser is that most losses associated with amplified spontaneous emission (ASE) are eliminated. ASE is a significant problem with pulsed dye lasers due to the high gain cross-sections of laser dyes. In addition, losses due to fluorescence decay can be minimized if the rate of stimulated emission is comparable to or greater than the fluorescence decay rate. An eventual goal of this approach is to engineer an enclosed or jetless dye

laser that would use more conventional and easily implemented dye cuvettes. Note that for pulsed, nanosecond duration dye laser, the singlet-triplet crossing problem is eliminated, allowing the use of a standard dye cuvette.

Pulsed operation may be achieved with higher diode energies and/or a more sophisticated and complex pump format and resonator design. In fact, we have identified a promising design concept to achieve pulsed operation using synchronous pumping. This concept will be described later in this report.

In Technical Objective 3, we characterized the two dyes chosen in Technical Objective 1 to obtain critical parameters such as absorption/emission spectra (cross-sections), radiative lifetimes, and quantum yields. PSI's final report describing these experiments is included in Appendix A of this report. These measurements have been included in the design analyses for efficient operation of a diode-pumped dye laser and will be described in detail in the following section.

Figure 1. CW Diode Pumped Dye Laser Concept

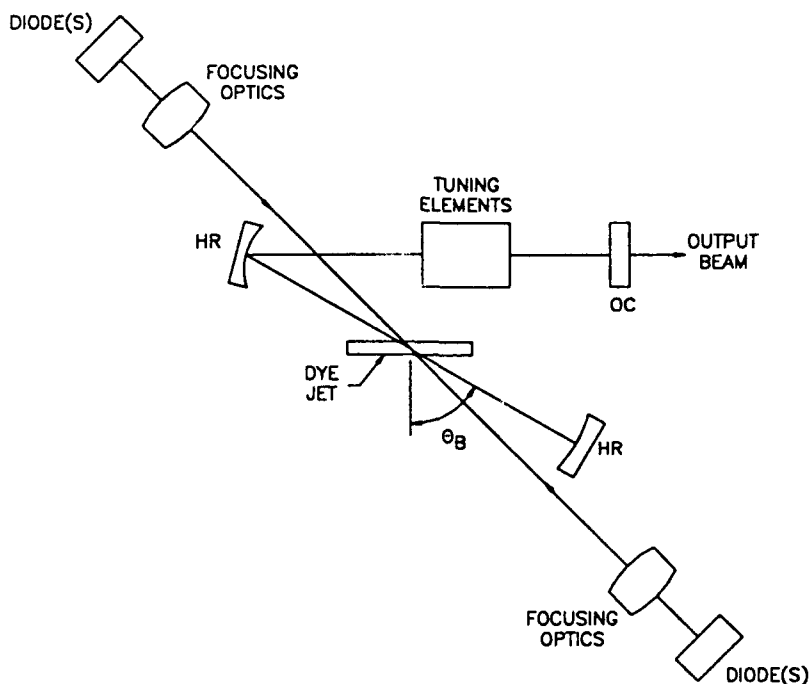

II. Work Completed

Technical Objective 3

This report describes work accomplished in Technical Objective 3 to complete this Phase I SBIR project. The two laser dyes selected previously have been characterized and, using the parameters generated, two dye laser designs have been analyzed and optimized for high efficiency operation. The following sections discuss these accomplishments in more detail.

Laser Dye Characterization

Under a subcontract to PSI, detailed measurements of laser dye characteristics were performed on the two laser dyes selected in Technical Objective 1 of this project. For comparison purposes, the dye Rhodamine 590 (also known as Rhodamine 6G or Rd-590) was also characterized as its parameters are well known and documented. These measurements determined the dye absorption/emission spectra (cross-sections), radiative lifetimes, and quantum yields. Appendix A contains PSI's Final Report describing these experiments in detail - equipment used, procedures, and initial data reduction. We have further processed the absorption/emission spectra to obtain the singlet absorption and emission cross-sections. These are shown in Figures 2 and 3 for the LD-800 and IR-26 dyes, respectively.

Table 2 lists the relevant optical properties of the three dyes. As noted in Table 2, the quantum yields measured are rather low for LD-800 and IR-26. This is partially due to the fact that such calculations are based on absolute spectrometry for which it is difficult to establish accurate instrument calibration. The LD-800 quantum yield is probably reasonably accurate since its emission spectrum is closer to the standard Rd-590 dye and is easier to calibrate. On the other hand, there is no standard in the 1 μ M region resulting in poorer calibration for the IR-26 dye fluorescence measurement and, thus, quantum yield calculation.

Our calculated quantum yield of 8.6% for the LD-800 dye is, nevertheless, significantly lower than the reported value of 39% [1]. A probable source of discrepancy for this is that we used methanol for the solvent and the reported value was for dichloroethane. In a similar dye, the quantum yield is reported to change from 50% in dichloroethane to 16% in ethanol [1]. This implies that the solvent may indeed have a large effect on the quantum efficiency. Clearly, further measurements should be performed on these dyes in other solvents.

For our design analysis purposes, described in the next section, we have chosen to bracket the performance predictions. At the low end, we used our

Table 2. Optical Properties of Selected Laser Dyes

Parameter	Rd-590	LD-800	IR-26
Solvent	Methanol	Methanol	Dichloroethane
Pump Emission Wavelength, λ_p (nm)	520	670	1080
Singlet Absorption Cross-Section, σ_p (cm ²)	4.5×10^{-16}	3.7×10^{-16}	5.6×10^{-16}
Peak Dye Emission Wavelength, λ_e (nm)	570	720	1190
Peak Emission Cross-Section, σ_e (cm ²)	2.2×10^{-16}	2.9×10^{-16}	1.9×10^{-16}
Quantum Yield, Φ (%)	95	8.6	0.1
Radiative Lifetime, τ (ns)	3.9	8.2	14.4

Figure 2. LD-800 Absorption/Emission Spectra

Cross-Sections vs. Wavelength

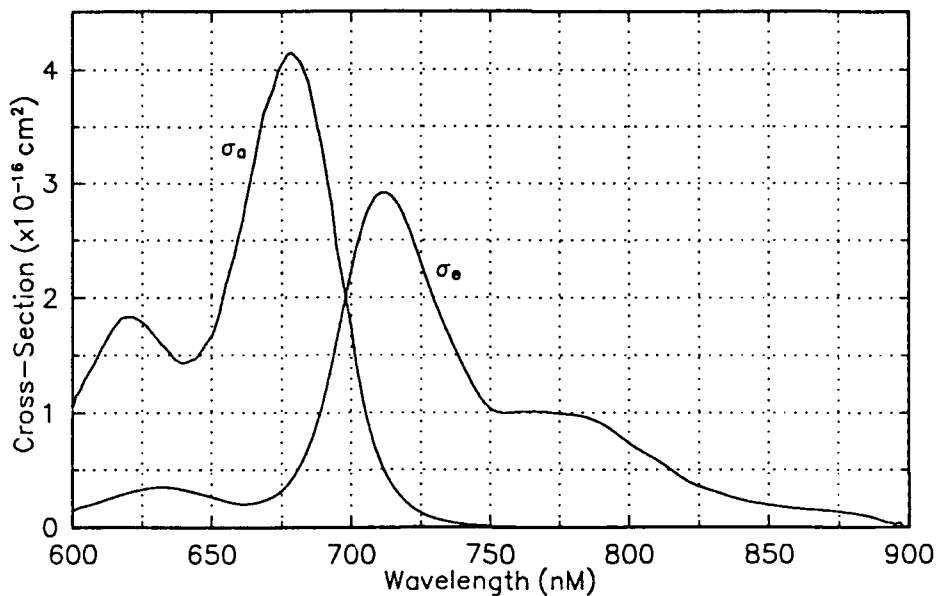
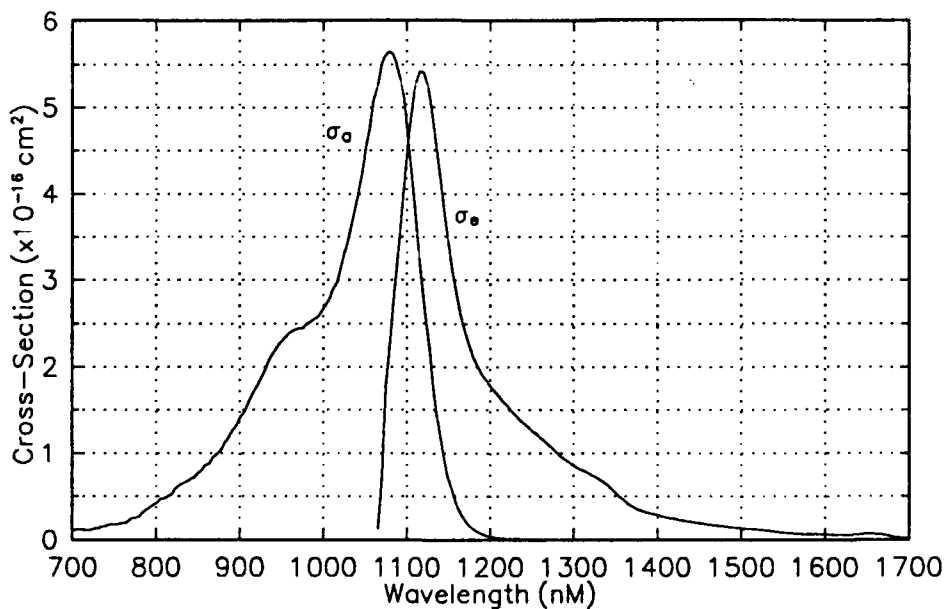

Figure 3. IR-26 Absorption/Emission Spectra

Cross-Sections vs. Wavelength



measured values for quantum yield - 8.6% and 0.1% for LD-800 and IR-26, respectively. At the high end, for the LD-800 dye, we used the reported 39% value, while for the IR-26 dye, we (arbitrarily) used an order of magnitude higher value of 1%. We expect the actual performance to fall within the range calculated.

CW Diode Pumped Dye Laser Design

We have analyzed the operation of a CW DPDL for the selected laser dyes, using the optical properties data listed in Table 2 with the cross-section spectra shown in Figures 2 and 3. While the stimulated emission cross-sections of the three dyes is quite comparable, the quantum yields of the LD-800 and IR-26 dyes are significantly lower than the Rd-590. In addition, the radiative lifetimes are longer than for Rd-590. If we make the reasonable assumption that the singlet-triplet crossing is a negligible effect, then the threshold intensity, I_p^{thr} , for the CW dye laser is given by the equation [2]

$$I_p^{thr} = \frac{hc\lambda_p}{\sigma_p \tau \Phi} \left(\frac{T}{NL(\sigma_e - \sigma_a) - T} \right) \quad (1)$$

Here, λ_p , σ_p , σ_e , Φ , and τ are as given in Table 2, σ_a is the dye absorption cross-section (cm^2) at λ_e , N is the dye concentration (cm^{-3}), and L is the dye jet length (cm). T is the total resonator loss given by

$$T = \alpha + (1-\alpha)(1-R_\infty) \quad (2)$$

where α represents the passive resonator loss due to effects such as surface scattering, and R_∞ is the outcoupler reflectivity. For the calculations presented here, we assume that the dye concentration, N , is nominally $6 \times 10^{17} \text{ cm}^{-3}$ and the dye jet length is 0.01 cm. This provides in excess of 90% absorption of the pump light.

From Eqn. (1), we see that the threshold intensity, I_p^{thr} , is directly dependent upon the outcoupler reflectivity, Eqn. (2), and the wavelength dependent absorption and stimulated-emission cross-sections, $\sigma_a(\lambda)$ and $\sigma_e(\lambda)$, respectively. Using this data and the relevant parameters for LD-800 and IR-26 from Table 2, we can generate the plots shown in Figures 4 and 5. The two plots in Figure 4 show the variation of I_p^{thr} for LD-800 given our measured value for quantum yield, $\Phi=8.6\%$ (Figure 4a), and the reported $\Phi=39\%$ (Figure 4b). Likewise, Figure 5a shows the variation of I_p^{thr} for IR-26 given our measured value of $\Phi=0.1\%$ and a more optimistic value of $\Phi=1.0\%$ (Figure 5b). As mentioned earlier, due to possible inaccuracies or discrepancies of the measured values for quantum yield, we have bracketed the performance predictions using our lower measured values and the possible higher values.

From Figure 4, we can see that threshold can easily be achieved for $\Phi=39\%$ with 20 kW/cm^2 of pump intensity and R_∞ between 92 and 99%. For $\Phi=8.6\%$, the required outcoupler reflectivity is about 99% and for good tuning about 99.9% for the same pump intensity. From Figure 5, it appears that somewhat higher pump intensities are required to achieve threshold and realize reasonable tuning range.

Calculations show that Rd-590 has the lowest oscillation threshold, followed by LD-800 and IR-26. This behavior is primarily because of the lower quantum yield of the latter two dyes. Modern day argon pumped dye lasers operate with typically a watt of output power and produce usable dye laser output with typically a few tens of kW/cm^2 of intensity. This is obtained with dye jets placed at the resonator minimum waist. For good efficiency, the spot size of the focused diode laser or array should be comparable to the fundamental mode spot size at the resonator waist. Diodes used to pump modern solid-state lasers can easily achieve a spot diameter of $50 \mu\text{m}$ when focused with standard gradient index lenses. Assuming a reasonable 200 mW of CW power from a red diode, this corresponds to about 10 kW/cm^2 of intensity. Pumping from both sides, as shown in Figure 1, can double this value. As can be seen from Figure 4, this intensity is more than sufficient to achieve threshold for the dye LD-800, the minimum occurring at a wavelength of approximately 715 nm. As seen in Figure 5, the dye IR-26 will require significantly higher pump intensity and/or higher outcoupler reflectivity (>99%) to reach threshold.

Recent results reported to us by McDonnell Douglas indicate that 400 mW per diode is routinely achieved. Thus, up to 40 kW/cm^2 of pump intensity will be available from two 670 nm diodes.

As a result of our analysis, and budgetary constraints (diode cost), we will attempt to achieve oscillation using the dye LD-800 in a proposed Phase II program. General conclusions reached during the completion of this Technical Objective are that diode pumping a CW dye laser appears quite feasible, with presently available diode lasers, and that outcoupler transmission will be small if one or two single emitters (diodes) are used. With the advent of higher power diode arrays, however, the outcoupler transmission will increase.

We have analyzed the diode-pumped LD-800 and IR-26 lasers in more detail. Of interest here is the extraction efficiency achievable with this system. Using the same assumption as in connection with Eqn. (1), one can show that the CW dye gain g is given by the equation

Figure 4a. LD-800 Threshold Pump Intensity vs. Wavelength

Outcoupler Reflectivity Varied - $\Phi = 8.60\%$

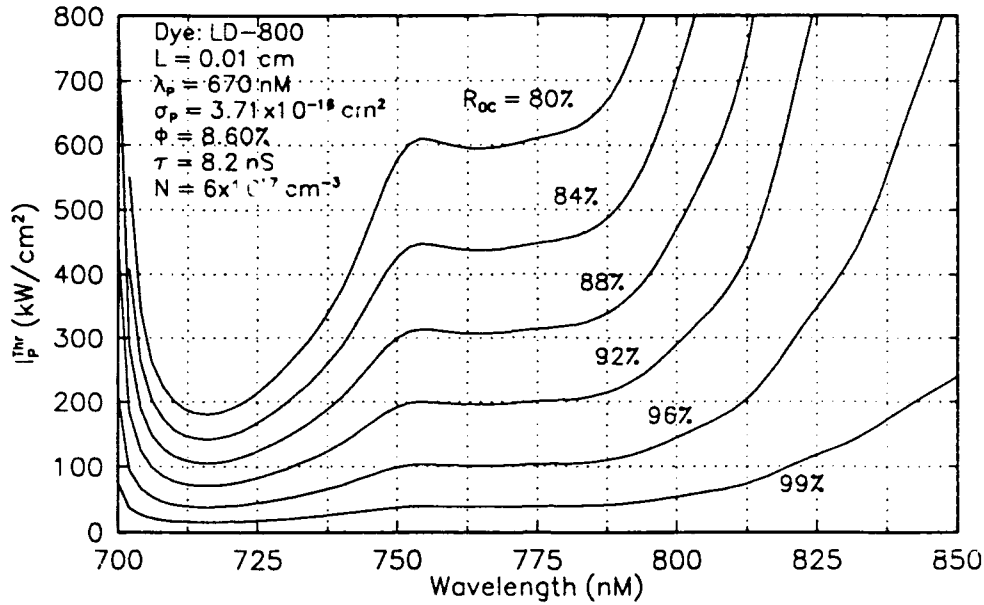

Figure 4b. LD-800 Threshold Pump Intensity vs. Wavelength

Outcoupler Reflectivity Varied - $\Phi = 39.0\%$

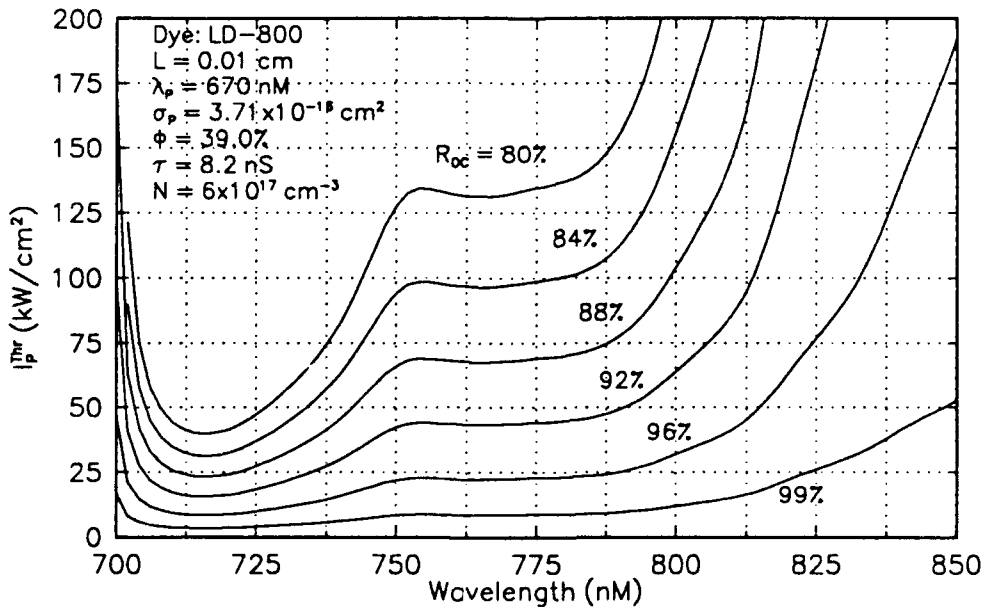

Figure 5a. IR-26 Threshold Pump Intensity vs. Wavelength

Outcoupler Reflectivity Varied - $\Phi = 0.1\%$

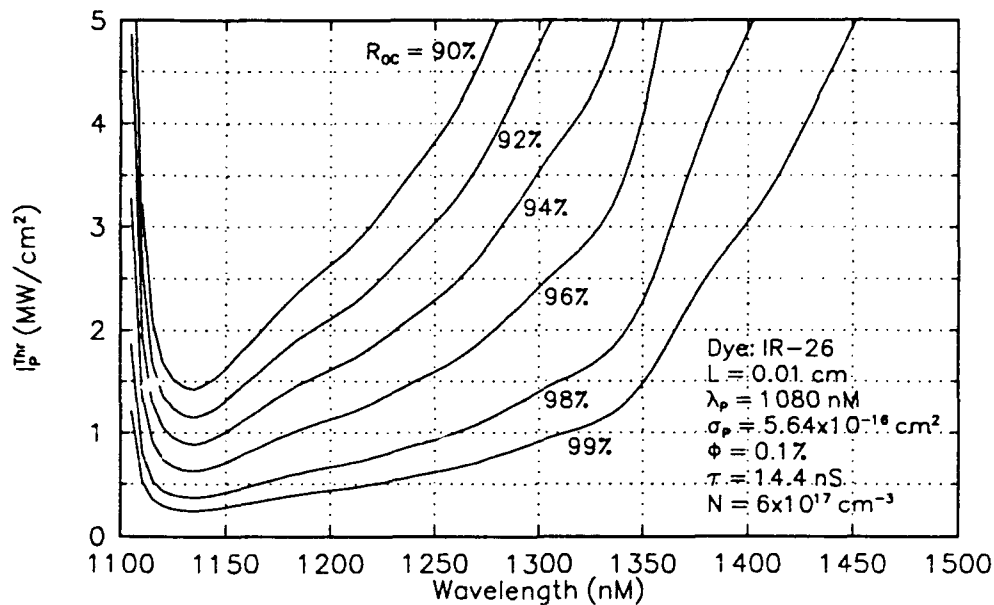
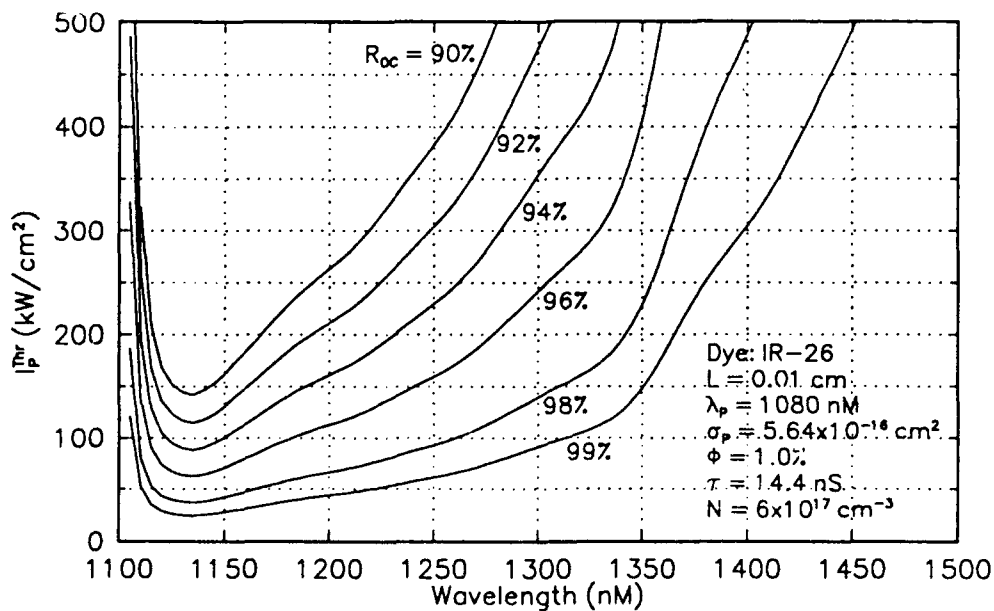

Figure 5b. IR-26 Threshold Pump Intensity vs. Wavelength

Outcoupler Reflectivity Varied - $\Phi = 1.0\%$



$$g = \frac{g_0}{1 + \frac{I_e}{I_s}} \quad (3)$$

where I_e is the dye laser emission intensity and I_s the dye saturation intensity. The gain g_0 is given by

$$g_0 = \frac{N\sigma_p J_p \tau \Phi (\sigma_e - \sigma_a)}{hc\lambda_p + \sigma_p J_p \tau \Phi} \quad (4)$$

where I_p is the diode pump intensity. If we make the reasonable assumption that we will utilize two visible laser diodes to pump the dye, and that each is focused to a spot size of 50 μM and completely absorbed, then the pump intensity is about 20 kW/cm^2 . In order to calculate the expected extraction efficiency, we use the standard relationship

$$\eta_{\text{EX}} = \left(\frac{1 - R_{\text{oc}}}{1 + R_{\text{oc}}} \right) \left(\frac{2g_0 L}{\alpha - \ln(R_{\text{oc}})} - 1 \right) \quad (5)$$

Here, R_{oc} is the outcoupler reflectivity and α the resonator losses. If we assume $I_p = 20 \text{ kW}/\text{cm}^2$, then, by using Eqns. (4) and (5) as well as the wavelength dependent σ_a and σ_e , we can generate the plots shown in Figures 6 and 7. In Figure 6a, we show the extraction efficiency for LD-800 as a function of wavelength and at the optimum outcoupler reflectivity. Figure 6b shows the optimum outcoupler reflectivity vs. wavelength for LD-800. Figures 7a and 7b show the same calculations for IR-26. Again, we show η_{EX} and optimum R_{oc} for both values of Φ . Note that for the lower quantum yield the extraction efficiency is also lower; the use of higher power diodes, as they become available, however, increases η_{EX} . While currently available diodes are nominally rated at 200 mW, they may be run at 500 mW for short times (a total of 1.0 W of pump power), hence our maximum pump intensity will be 50 kW/cm^2 . Even though the actual efficiency will be somewhat lower due to the incomplete overlap of the dye laser resonator mode and the diode pump focal spots, and the incomplete absorption of the pump light by the dye, our calculations indicate that, with the dye LD-800, we can achieve about a ten fold increase in wallplug efficiency over conventional flashlamp-pumped Nd:YAG pumped dye laser systems. This efficiency improvement is not as clear for the diode-pumped IR-26 dye laser at these pump powers.

Pulsed Diode-Pumped Dye Laser

We have developed a conceptual design for a synchronously-pumped dye laser, shown in Figure 8, that offers the promise of scaling to large energy/pulse. This concept will utilize diode arrays that are modulated in such a way that the array pulsewidth is of the order of a nanosecond, and the repetition rate is adjusted so that the pump pulse ar-

rives at the dye cell coincident with the circulating dye pulse.

The circulating pulse concept is shown in more detail in Figure 9: the diode array pump pulses, at most a few nanoseconds in duration, are pulsed at a frequency of 100-300 MHz for N pulses, where N is a number that will be determined with more precision during a follow-on Phase II contract. The circulating dye pulse, which grows from spontaneous-emission noise produced by the first pump pulse, continually increases in energy from each round-trip dye cell amplification, until the desired energy per pulse is reached. Every effort is made to reduce the round trip cavity loss by utilizing high reflectivity mirrors, operating in the fundamental TEM00 mode where diffraction losses are minimum, and by minimizing the insertion losses due to the Faraday rotator and polarizer. Finally, after N pulses, the Faraday rotator is switched and the laser output pulse emerges from the polarizer. Following the recovery of the Faraday rotator, the sequence is then repeated.

In Table 3 below we show the ring resonator length (ignoring the dye jet optical thickness), the round-trip time, and the required diode-array repetition rate to achieve synchronous pumping. It can be seen that for a 1-3 M long resonator, the round-trip time is in the range 3.33-10 nS, and the required diode-array repetition rate is only in the range 100-300 MHz. This repetition rate is easily achievable with single diodes or diode-arrays. Note that, while in principle the diode array could be activated every second, third, or more round-trips of the resonator, thus reducing the array repetition rate, this is not acceptable here due to the finite absorption of organic dyes whose absorption and emission bands significantly overlap. An attractive alternative here would be to use a number of diode arrays whose excitation pulses are interleaved, effectively increasing the repetition rate.

Another consideration for this laser is that the switching time of the Faraday rotator must be only a few nanoseconds; this is also achievable with modern Faraday rotator designs. This limitation will likely make the use of a resonator with a minimum length of approximately 1 M necessary.

We have examined what pumping conditions may be achieved with modern diode-array technology. A safe peak-intensity limitation for presently available diode arrays is 1.5 kW/cm^2 . Thermal limitations dictate that the array duty cycle be limited to 5%, although duty cycles 2-3 times as large have been demonstrated. The combination of peak power and duty cycle limitations leads to an diode-array average power limit of 150 W/cm^2 . If we choose a pump pulse duration of 1 nS, ideal for pumping most dye lasers, then the maximum duty cycle-limited repetition rate is 50 MHz, and a 6 M long resonator must

Figure 6a. LD-800 Extraction Efficiency (η_{EX}) vs. Wavelength

Diode Pump Power (P_p) and Quantum Yield (Φ) Varied

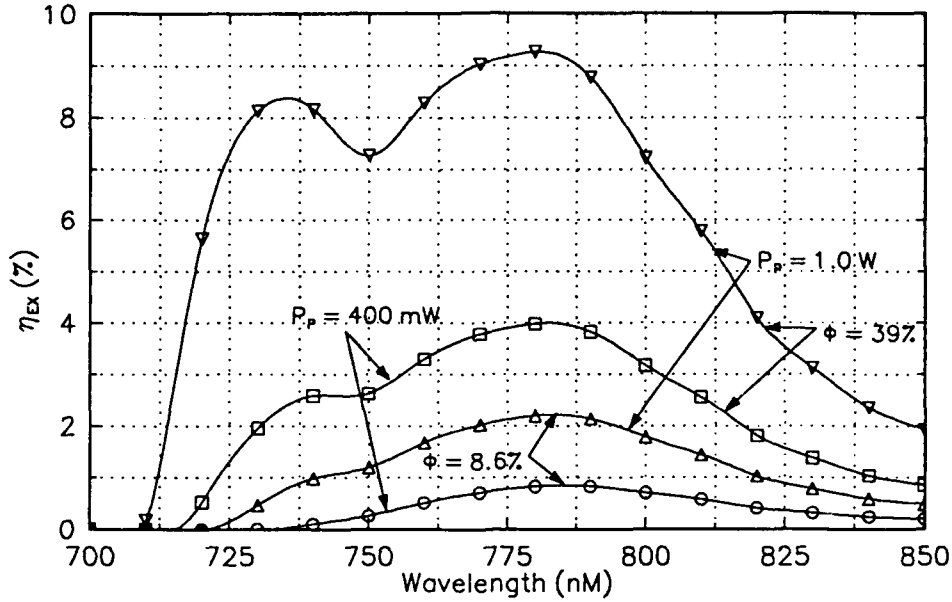

Figure 6b. LD-800 Optimum Reflectivity (R_{OC}) vs. Wavelength

Diode Pump Power (P_p) and Quantum Yield (Φ) Varied

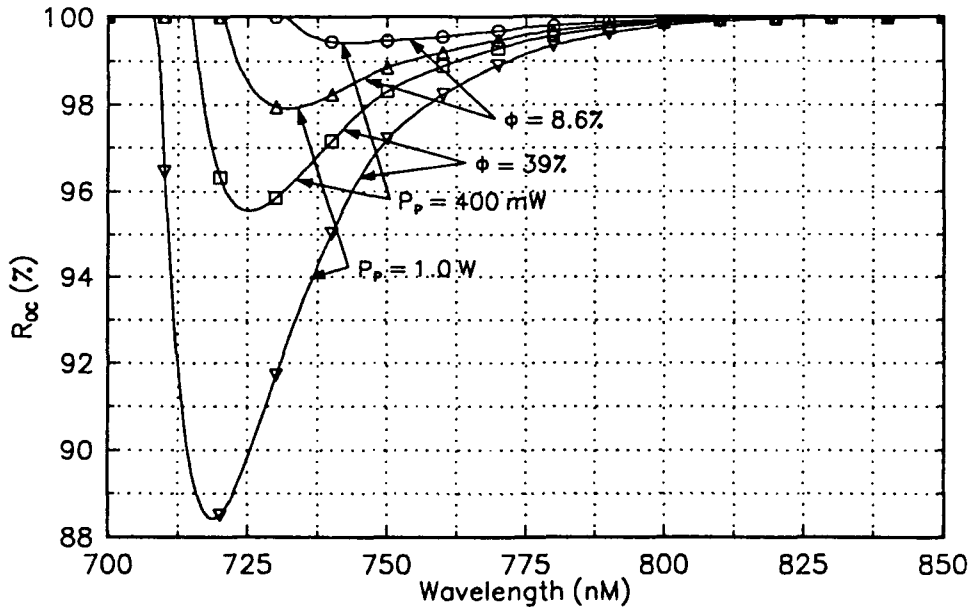

Figure 7a. IR-26 Extraction Efficiency (η_{EX}) vs. Wavelength

Diode Pump Power (P_p) and Quantum Yield (Φ) Varied

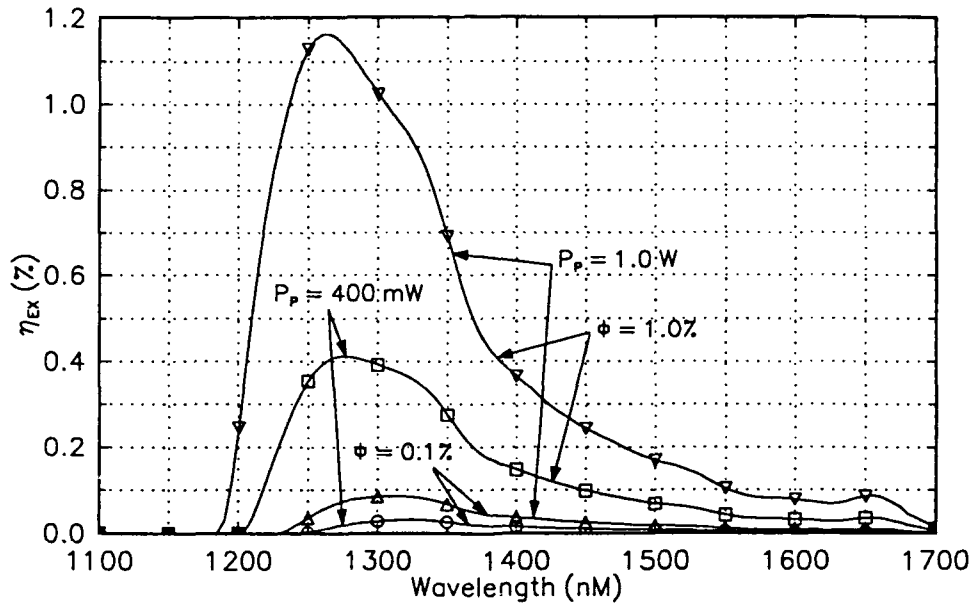
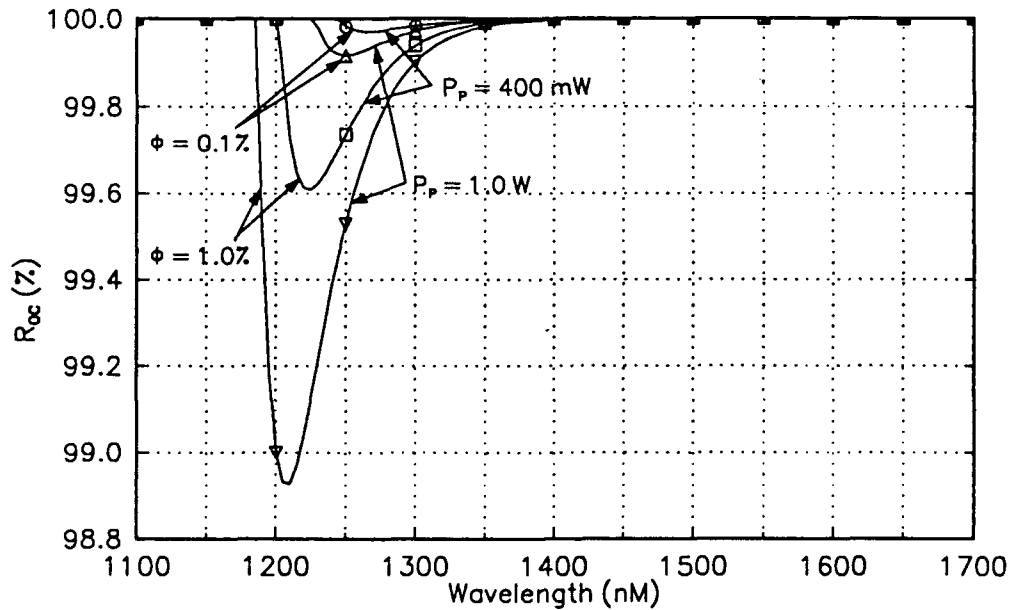

Figure 7b. IR-26 Optimum Reflectivity (R_{OC}) vs. Wavelength

Diode Pump Power (P_p) and Quantum Yield (Φ) Varied



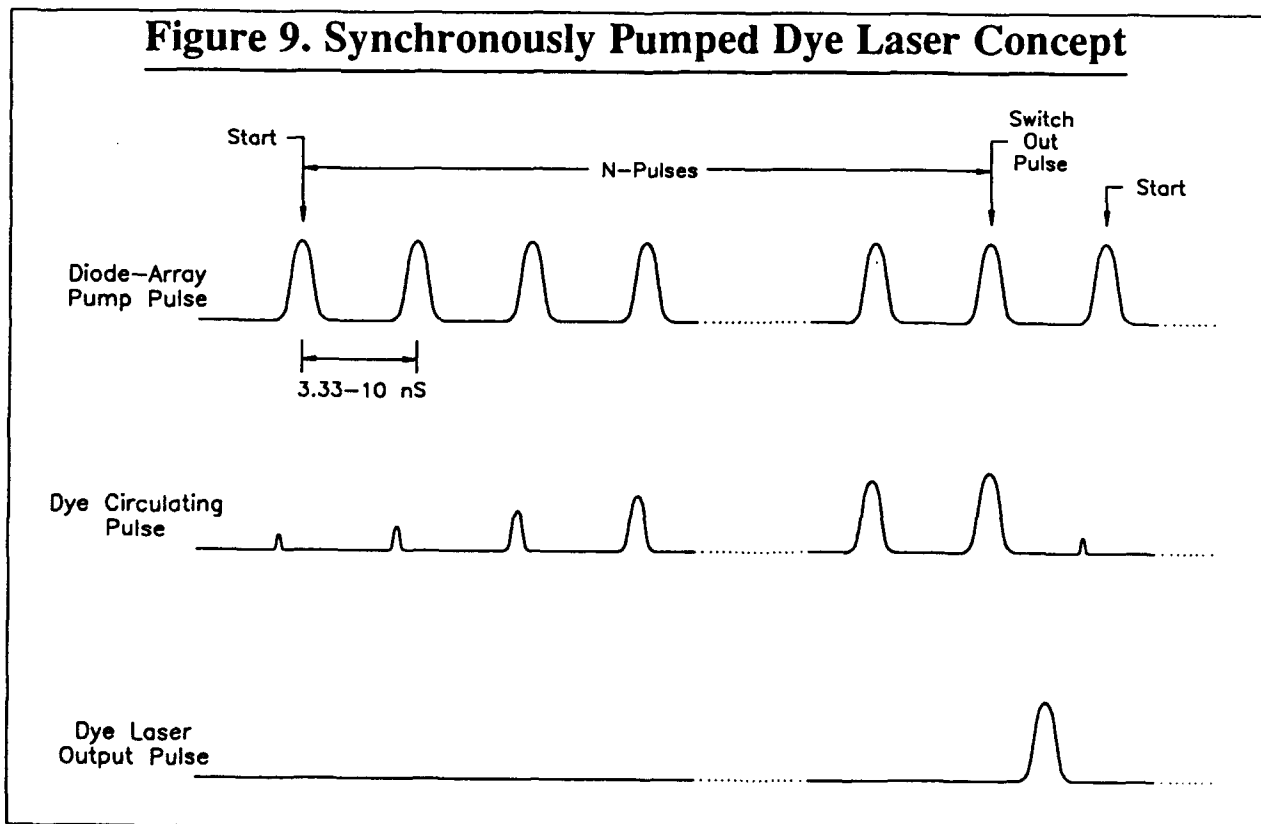
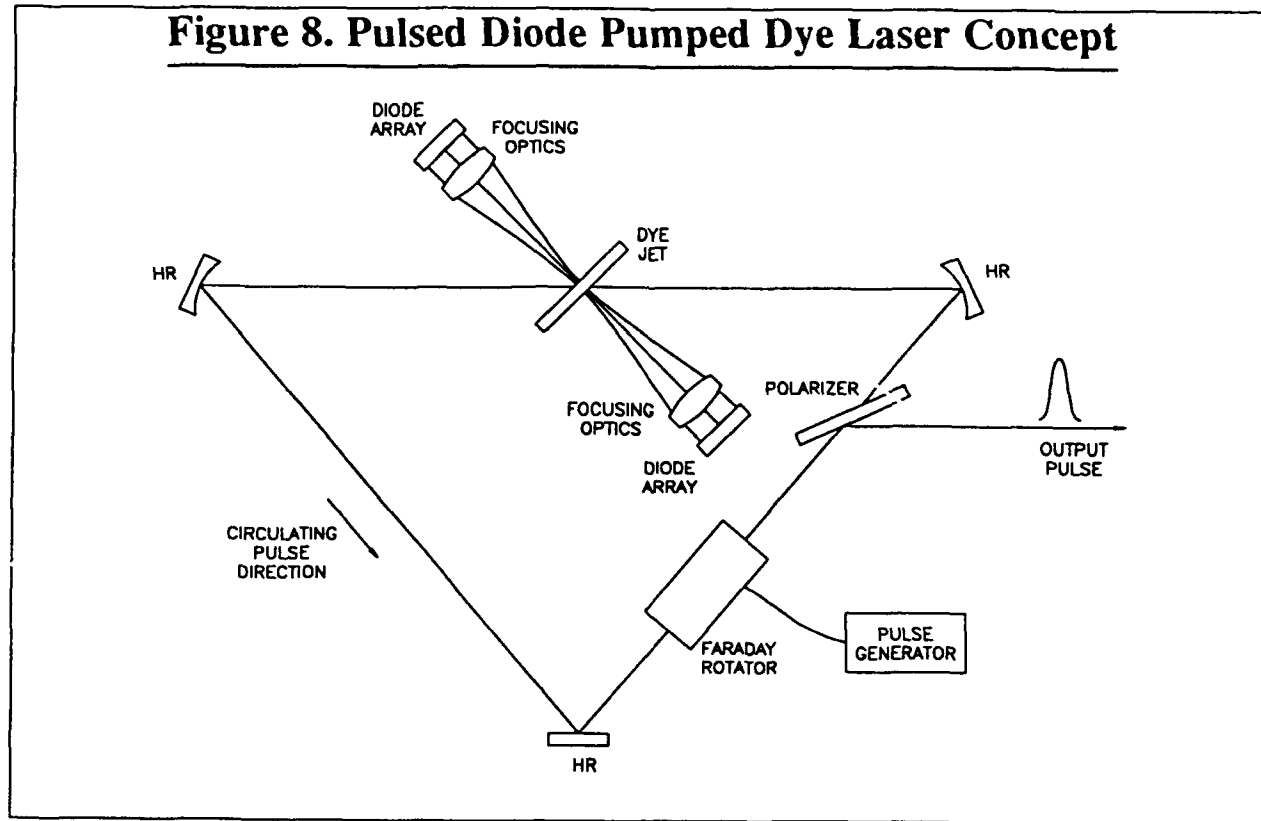

Table 3. Synchronous Dye Laser Pumping Conditions

Resonator Length (M)	Roundtrip Time (nS)	Array Repetition Rate (MHz)
1	3.33	300
2	6.67	150
3	10.00	100
4	13.33	75
5	16.67	60
6	20.00	50

be used. Carrying this further, assume that two diode arrays are used, with each array's pulses incident upon the dye medium at the same time. Further assume that each array has 1 cm² of area, thus 3 kW of peak power is available per pulse. Assuming that all of the diode light is absorbed, then 3 μJ are deposited in the dye per pulse. If the desired output pulse energy is 100 mJ, and the assumed overall extraction efficiency is 25%, then 400 mJ of pump light must be deposited in the dye. This corresponds to 133,333 individual pump pulses, each containing 3 μJ; the time to deposit the energy is then 2.67 mS. Then the maximum dye laser output repetition rate is 375 Hz. This corresponds to a dye laser output average power of 37.5 W or a wallplug efficiency of 10%.

Detailed modeling of this synchronous pumping approach, while beyond the scope of this Phase I program, is proposed to be completed during a fol-

low-on Phase II program. Until such modeling is carried out, the expected extraction efficiency number assumed in the above analysis cannot be verified. However, even if the extraction efficiency is as pessimistically low as 10%, a wallplug efficiency of 4% results and the pulsed laser concept is still attractive.

From our analysis, it is clear that the major unanswered question regarding the synchronous pumping approach is the achievable pulse duration of the diode array. The minimum pulse duration will depend upon such considerations as the parasitic capacitance of the array, the array electronic transit time, and the power supply design. We are not aware of any published data regarding the nanosecond excitation of diode arrays and will thus propose that we experimentally investigate this issue early in a follow-on Phase II program.

III. Summary

In summary of the major findings in this Phase I SBIR program, it has been concluded that:

(1) CW diode pumping of dye lasers is indeed practical using currently available diode laser and dye laser technology. Efficiency improvements of at least an order of magnitude over flashlamp- and laser-pumped dye lasers are achievable with the dye LD-800 pumped by 670 nM laser diodes, and tunable over a range of approximately 725-825 nM. The dye IR-26 appears less adequate for diode-pumping at this time. The CW DPDL concept analyzed in this program is reasonably straightforward and demonstrable for the diode pumped LD-800 dye laser.

(2) Further characterization of the LD-800 laser dye needs to be performed in order to more adequately determine performance predictions and optimizations. The sensitivity of quantum yield with solvent must be measured.

(3) Pulsed diode pumping of dye lasers is also feasible with today's diode laser technology. Again, 670 nM diode laser pumping of the dye LD-800 appears to be a good candidate. A pulsed DPDL concept has been analyzed to first order and appears achievable. More analysis and design need to be performed during a Phase II follow-on contract.

IV. Conclusion

In this Phase I SBIR program, LTA has investigated the feasibility of constructing an efficient, tunable diode-pumped dye laser. We have considered the state-of-the-art in both diode and dye lasers as applicable and available in the near term, while considering longer term expected advances in terms of diode laser emission characteristics. We have found that, for the dye LD-800 pumped by currently available laser diodes emitting at 670 nm, it is indeed possible and practical to achieve efficient, tunable CW dye laser emission. Pulsed operation is also feasible.

In a follow-on Phase II SBIR program, we will propose to demonstrate a CW as well as a pulsed diode

pumped LD-800 dye laser. Early in the Phase II program, more detailed characterization of the dye LD-800 will be performed, as well as procurement of the necessary laser diode emitters and arrays. In parallel, we will more fully design and analyze the pulsed concept. We will then demonstrate the CW DPDL, followed by a demonstration of the pulsed DPDL. Much of the work proposed under the Phase II program will be performed in conjunction (sub-contract) with PSI who has been instrumental in the success of this Phase I program. We feel that the concept of diode pumping a dye laser is an exciting technology as well as having significant application to both the U.S. Army and commercial markets.

V. References

- [1] R. Raue, H. Harnisch and K.H. Drexhage, "Dyestuff Lasers and Light Collectors - Two New Fields of Application for Fluorescent Heterocyclic Compounds," *Heterocycles*, **21**(1), 167 (1984).
- [2] F.J. Duarte and L.W. Hillman, *Dye Laser Principles with Applications*, pp. 194-6 (Academic Press, San Diego, CA, 1990).

Appendix A

THE DETERMINATION OF LASER DYE CHARACTERISTICS

Final Report

Submitted to

Laser Technology Associates Inc.
25 Ozalid Road
Building 2, Room 226
Johnson City, New York 13790

Prepared by

S.J. Davis, R.F. Foutter, W.J. Kessler, and L.G. Piper

Physical Sciences Inc.
20 New England Business Center
Andover, MA 01810

12 June 1991



TABLE OF CONTENTS

	<u>Page</u>
ABSTRACT	1
INTRODUCTION	2
Fluorescence Measurements	3
Results	4

LIST OF FIGURES

<u>Figure</u>		<u>Page</u>
1	Apparatus for the Fluorescence Measurements of the IR-26 Dye	3
2	Absorption Spectrum for Rd-590 Dye at a Concentration of $1.23 \times 10^{-5}M$	4
3	Absorption Spectrum for LD-800 Dye at a Concentration of $2.42 \times 10^{-5}M$	5
4	Absorption Spectrum for IR-26 Dye at a Concentration of $2 \times 10^{-5}M$	5
5	Dependence of Rd-590 Peak Absorption Coefficient Upon the Product of the Dye Concentration and the Cell Length	6
6	Dependence of Rd-800 Peak Absorption Coefficient Upon the Product of the Dye Concentration and the Cell Length	6
7	Dependence of IR-26 Peak Absorption Coefficient Upon the Product of the Dye Concentration and the Cell Length	7
8	Fluorescence Spectrum of Rd-590 Dye for Excitation at 514 nm	8
9	Fluorescence Spectrum of LD-800 Dye for Excitation at 610 nm	9
10	Fluorescence Spectrum of IR-26 Dye for Excitation at 1064 nm	9

ABSTRACT

In this report we describe the results of a dye characterization study designed to determine dye parameters relevant to diode laser pumping. We have carried out four different experimental tests on several visible and near infrared laser dyes that have potential for direct diode laser pumping. This brief summary is intended to describe the procedures and the salient results of these characterization tests. We have included some plots of the data obtained. In addition, all data has been transferred onto floppy disks in an ASCII format. These disks are included under a separate cover as part of the deliverables.

INTRODUCTION

There is considerable interest in developing new laser sources that offer tunable outputs in the one micron wavelength range. In particular, incorporating a visible to near infrared diode laser to excite laser dyes may offer important advantages over existing dye lasers. These devices could be miniature in size and electrically efficient. At the present time, there have been no reports of dye lasers that are directly pumped by a diode laser. In order to design such a system one must incorporate important dye parameters into a design model. These parameters include the absorption cross section for the dye at the wavelength of the diode laser that will be used for the excitation. In addition, one must have accurate values for the radiative lifetime and fluorescence yields of the singlet state of the dye that will serve as the upper laser level.

In this report PSI describes the results of a series of measurements that determined important dye parameters. We have determined the following characteristics for three dyes, Exciton Rd 590, LD 800, and IR 26:

- . Absorption coefficients
- . Emission spectra
- . Radiative lifetimes of the singlet state of each dye.
- . Fluorescence yields for the dyes.

Selection of the dyes was done in consultation with researchers at LTA. The IR-26 dye was mixed in dichloroethane and both the Rd-590 and LD-800 were mixed in methanol. Several molar concentrations were used ranging from 1×10^{-3} to 1×10^{-6} M. The dyes were stored in Pyrex containers and transferred to 1 cm pathlength quartz cuvettes for the absorption measurements.

We have completed these measurements using several experimental set ups that are described below. The absorption spectra were obtained using a Shimadzu spectrophotometer

that provided absolute absorption spectra over the excitation range of 300 to 1200 nm. The dye absorption spectra were digitized and stored as ASCII files for later analysis. We determined both peak absorption coefficients and integrated absorptions. As we show later the integrated absorptions are valuable since one can determine the radiative transition probability from the integrated absorption.

Fluorescence Measurements

a) IR-26 dye

The IR-26 fluorescence spectra were obtained using a CVI Nd:YAG laser. This CW laser produces 500 mW at 1064 nm. The fluorescence was detected using an Acton model 502 spectrometer in combination with a Applied Detector Corporation model 403L intrinsic Ge detector. The entire detection system was calibrated for absolute spectral response using a quartz-halogen irradiance standard lamp. The output of the Ge detector was fed into a PC using an A/D converter and the spectra were collected using the LabTech Notebook software package. A block diagram of this apparatus is shown in Figure 1. We also measured the absorbed laser power for several concentrations of the dye using a Scientec model power meter. Spectra were recorded at several YAG laser power to assure that the dye was not saturated.

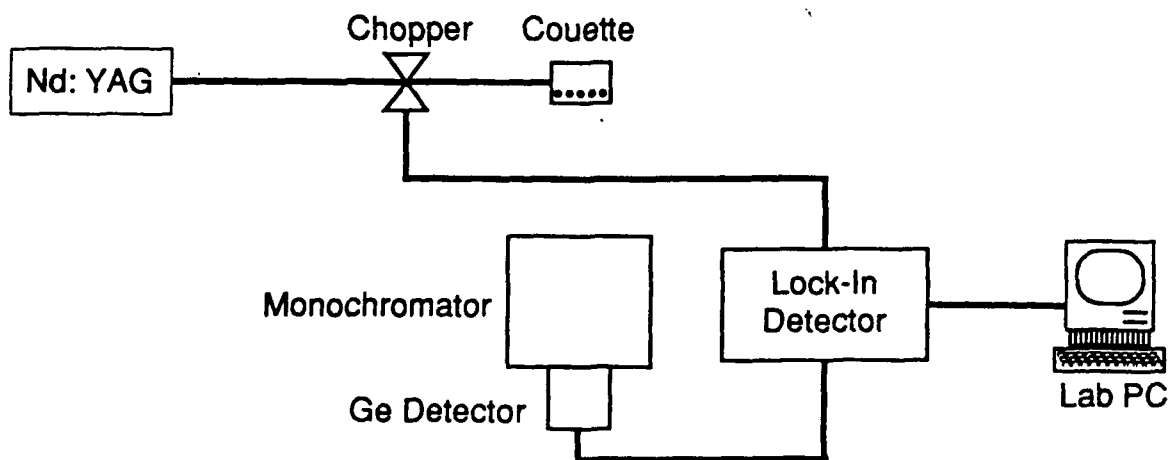

B-8327

Figure 1. Apparatus for the Fluorescence Measurements of the IR-26 Dye

b) LD-800 and Rd-590 dyes

We used a similar apparatus for measurements of the Rd-590 and LD-800 dyes. Two lasers were used, a Coherent Radiation Innova 100 Argon Ion laser at 514.5 nm and a Coherent model 699-05 ring dye laser which is tunable in the range 550 to 630 nm. These lasers provided good matches with strong absorption features for both Rd-590 and LD-800. The fluorescence was detected using a McPherson 0.3m (model 218) monochromator and a Hamamatsu 943-02 PMT with a GaAs photocathode. The photocurrent was measured using a Pacific Instruments photometer in the current mode. These data were also stored using LabTech Notebook. A Scientec model power meter was used to determine the fraction of the laser power that was absorbed by the dye.

Results

In Figures 2 through 4 we present absorption spectra for the three dyes each at a single concentration. The absolute absorption coefficients and integrated absorption coefficients were also determined at several dye concentrations. Plots showing the linearity of peak absorption coefficients are presented in Figures 5 through 7.

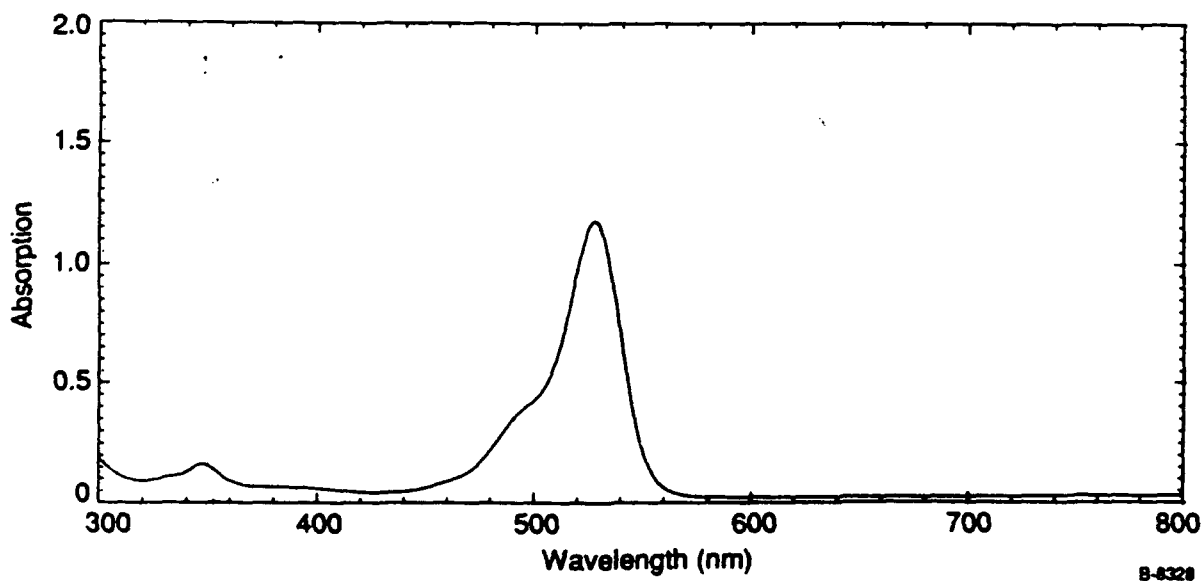

Figure 2. Absorption Spectrum for Rd-590 Dye at a Concentration of $1.23 \times 10^{-5}M$

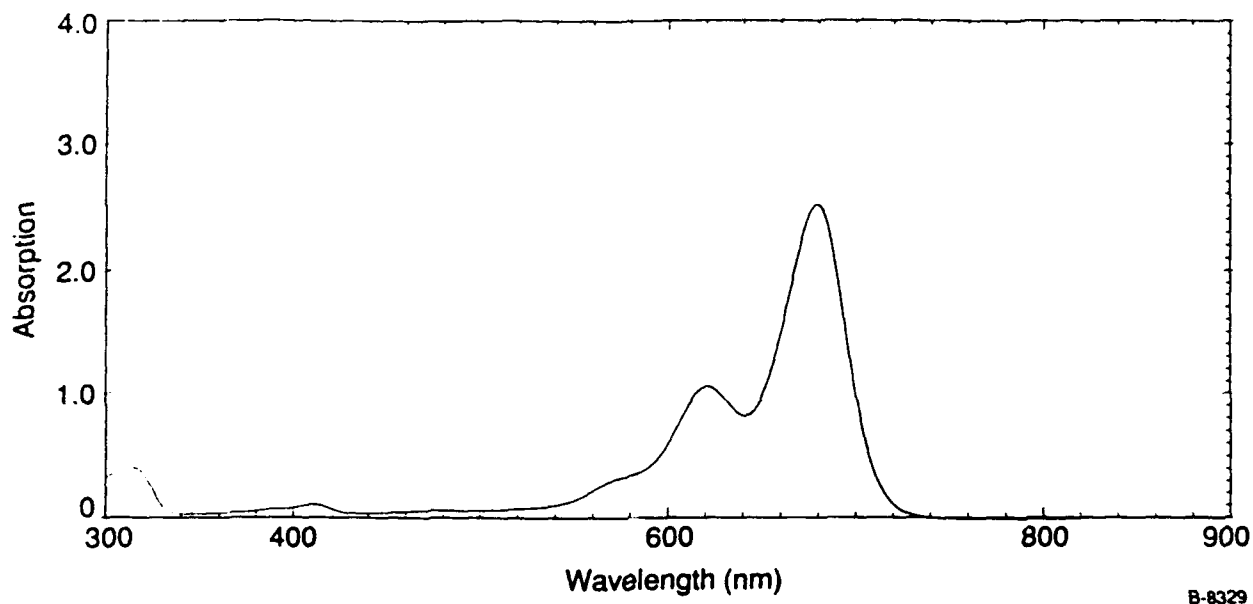

Figure 3. Absorption Spectrum for LD-800 Dye at a Concentration of $2.42 \times 10^{-5} \text{M}$

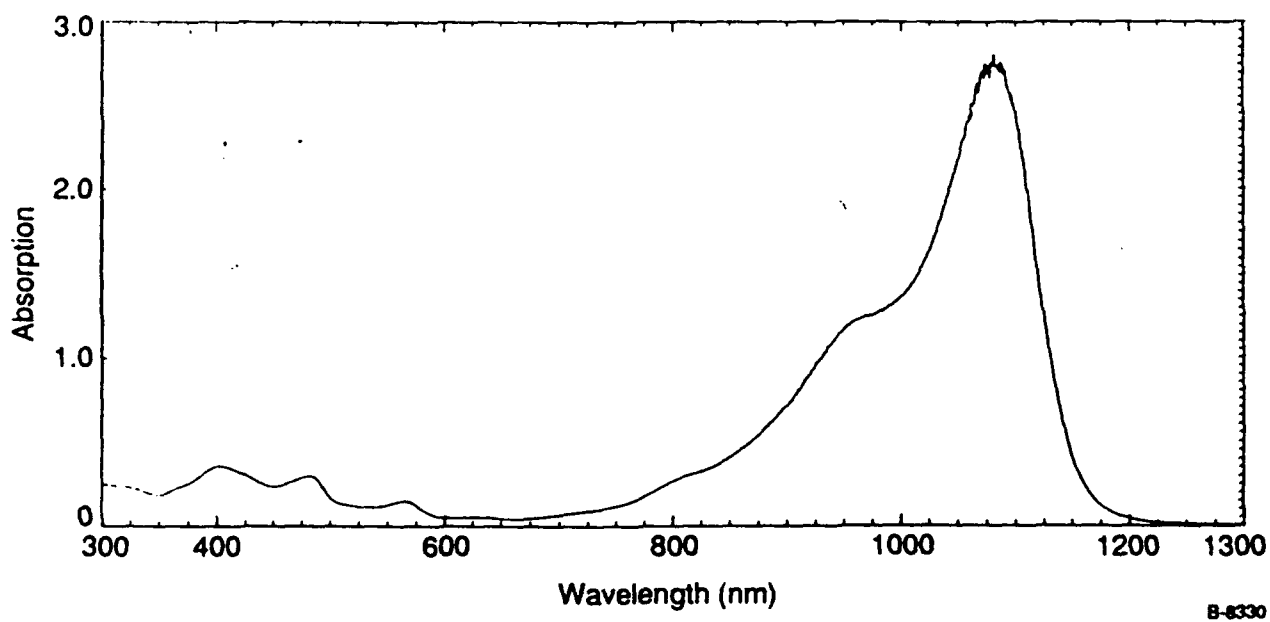
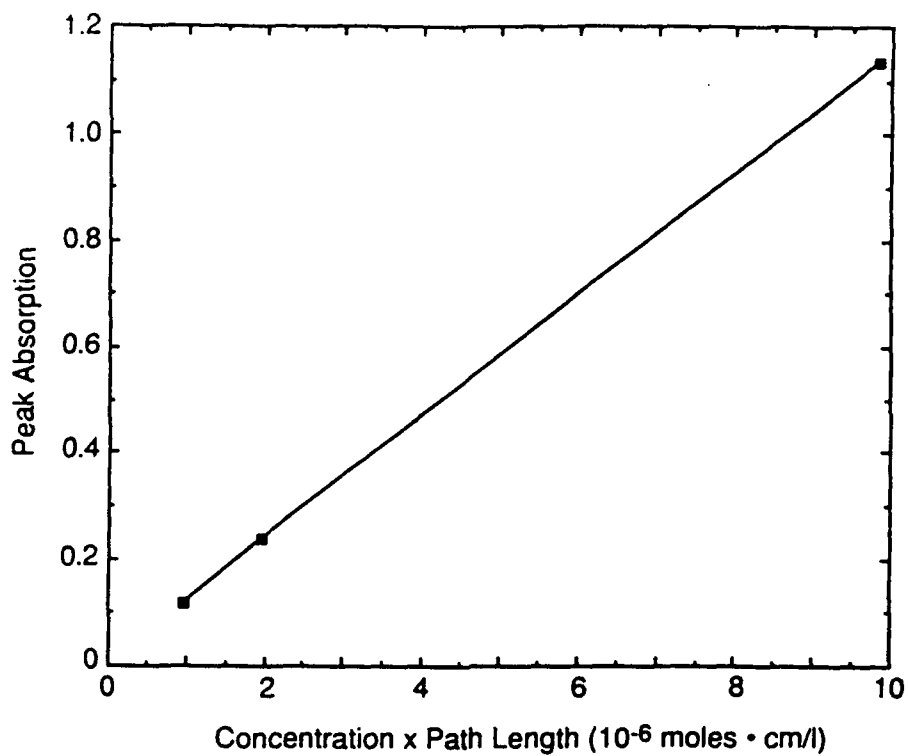
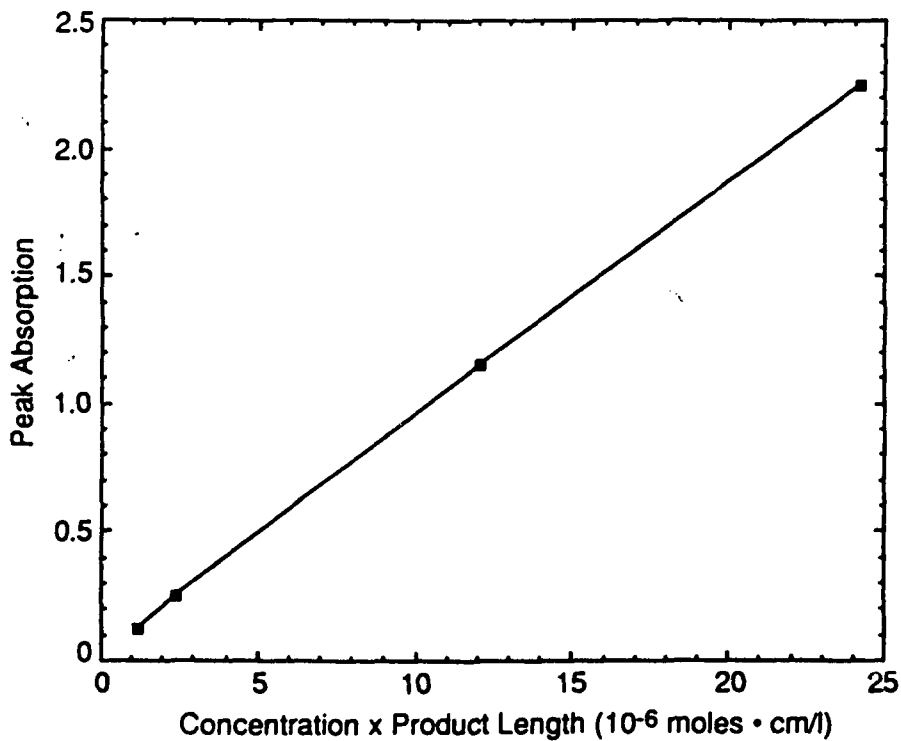

Figure 4. Absorption Spectrum for IR-26 Dye at a Concentration of $2 \times 10^{-5} \text{M}$



B-8331

Figure 5. Dependence of Rd-590 Peak Absorption Coefficient Upon the Product of the Dye Concentration and the Cell Length. (Cell length was 1 cm for all runs).



B-8332

Figure 6. Dependence of Rd-800 Peak Absorption Coefficient Upon the Product of the Dye Concentration and the Cell Length. (Cell length was 1 cm.)

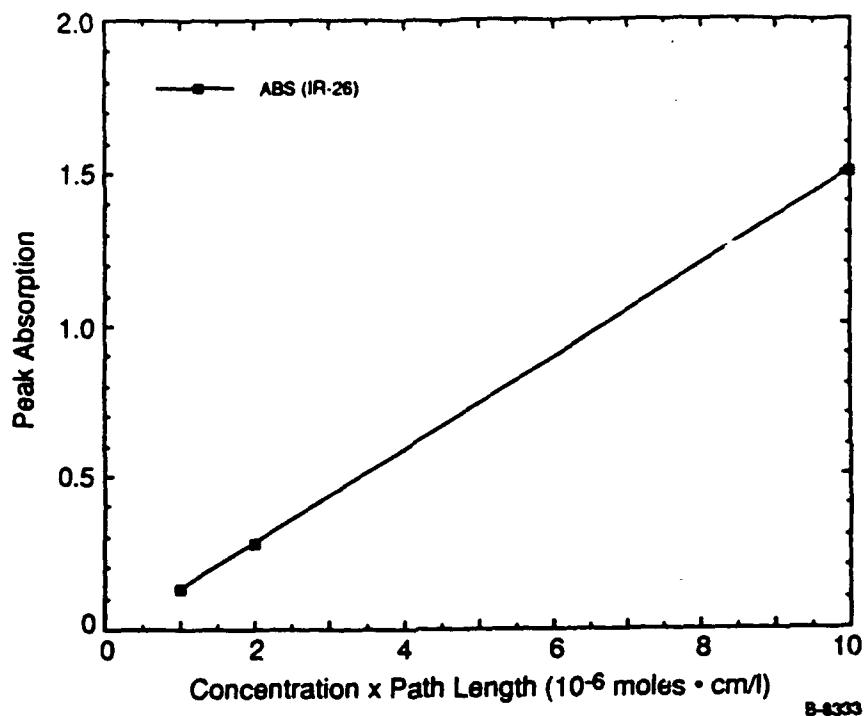

Figure 7. Dependence of IR-26 Peak Absorption Coefficient Upon the Product of the Dye Concentration and the Cell Length

The integrated absorption coefficient is also a relevant parameter since the radiative transition probability, A_{ul} , can be determined from a measurement of its value via Eq. (1).¹

$$A_{ul} = \frac{1}{\tau_0} = 2.880 \times 10^{-9} n^2 \langle \nu_f^{-3} \rangle^{-1} \frac{g_l}{g_u} \int \epsilon d(\ell\nu) \quad (1)$$

where

$$\frac{\int I(\nu) d\nu}{\int \nu^{-3} I(\nu) d\nu} = \langle \nu_f^{-3} \rangle^{-1} A_{ul} \quad (2)$$

In Eq. (1) n^2 is the index of refraction of the solvent, g_l/g_u is the degeneracy ratio for the lower and upper state, and ϵ is the extinction coefficient.

The radiative transition probability, $A_{u\ell}$ is critical in the design of a laser since it is closely related to the stimulated emission cross section. In general these two parameters are related by Eq. (3).

$$\sigma(\nu) = \frac{\lambda^2 A_{u\ell}}{8\pi} g(\nu) \quad (3)$$

where $g(\nu)$ is the lineshape function. In general, $g(\nu)$ can be approximated by the $(\Delta\nu)^{-1}$ when $(\Delta\nu)$ is the width of the emission spectrum.

In order to determine $A_{u\ell}$ from Eq. (1), one must determine frequency for the weighted average of the fluorescence emission as described by Eq. (2). We have analyzed the emission spectra including those presented in Figures 8 through 10 and from these we calculated the required average frequencies.

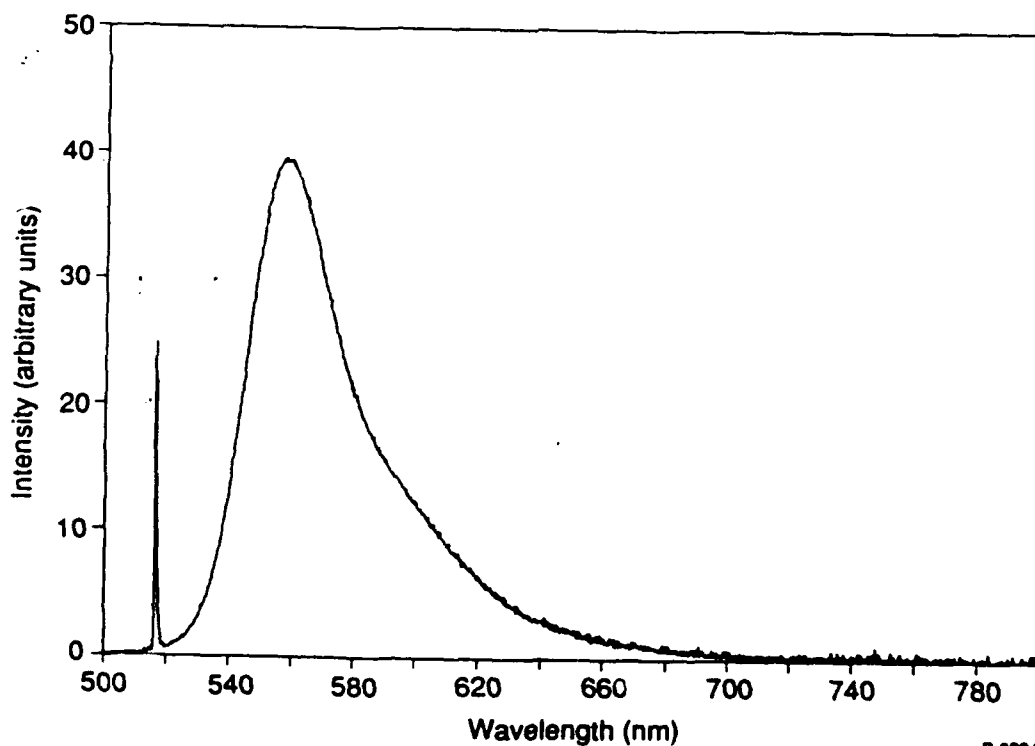
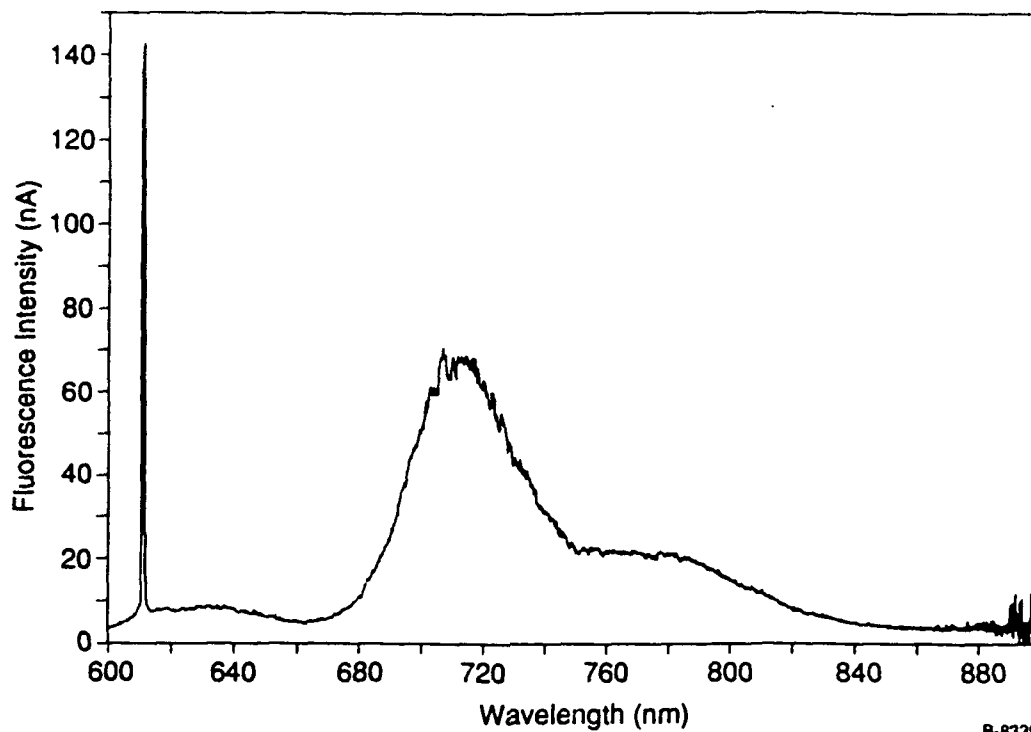
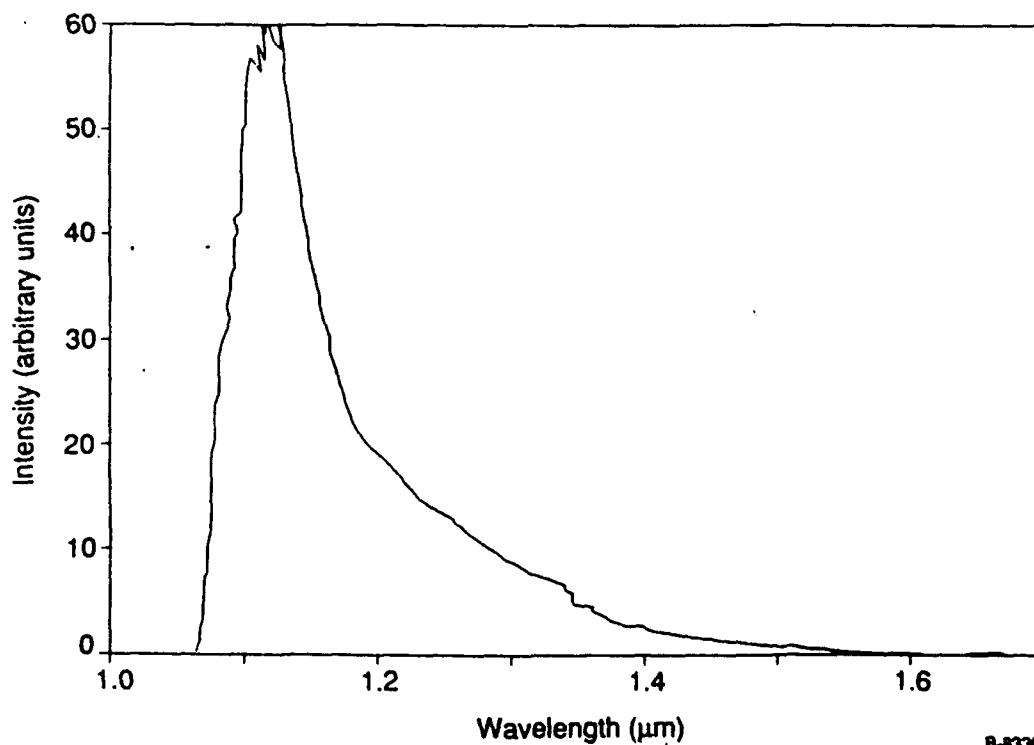

Figure 8. Fluorescence Spectrum of Rd-590 Dye for Excitation at 514 nm. Concentration was $1.23 \times 10^{-5}M$



B-8335

Figure 9. Fluorescence Spectrum of LD-800 Dye for Excitation at 610 nm. Concentration was $1.2 \times 10^{-5} \text{M}$



B-8336

Figure 10. Fluorescence Spectrum of IR-26 Dye for Excitation at 1064 nm. Concentration was $1.2 \times 10^{-5} \text{M}$

In Table 1 we summarize the absorption coefficient measurements for the three dyes. The average values that we determined for the maximum extinction coefficient ϵ_{\max} for the Rd-590 and LD-800 dyes are within 10 percent of values published previously.²⁻⁴ Published values for ϵ_{\max} for IR-26 are less precise and our value of 1.4×10^5 ℓ/m cm is consistent with those reported^{4,5} previously.

We have used the accepted value for the Rd-590 quantum efficiency is methanol, 95%, or a reference standard.⁶ The quantum efficiencies for LD-800 and IR-26 are referenced to that for Rd-590.

Table 1. Summary of the Absorption Coefficients for Rd-590, LD-800, and IR-26 Dyes

Dye	Concentration (m/l)	ϵ_{\max} (ℓ/m cm)	$\int \frac{\epsilon_{\nu} d\nu}{\nu}$
RD-590	1.25×10^{-5}	1.15×10^5	8.93×10^3
	2.46×10^{-6}	1.20×10^5	9.38×10^3
	1.23×10^{-6}	1.18×10^5	9.18×10^3
	Avg = $(1.18 \pm 0.02) \times 10^5$		Avg = $(9.16 \pm 0.18) \times 10^3$
LD-800	2.42×10^{-5}	9.28×10^4	7.59×10^3
	1.21×10^{-5}	9.5×10^4	8.07×10^3
	2.42×10^{-6}	10.3×10^4	10.3×10^3
	1.0×10^{-6}	10.4×10^4	10.5×10^3
Avg = $(9.87 \pm 0.48) \times 10^4$		Avg = $(9.12 \pm 1.30) \times 10^3$	
IR-26	1×10^{-5}	1.5×10^5	23.8×10^3
	2×10^{-6}	1.39×10^5	19.7×10^3
	1×10^{-6}	1.32×10^5	16.3×10^3
	Avg = $(1.40 \pm 0.07) \times 10^5$		Avg = $(19.9 \pm 3) \times 10^3$

The relative quantum efficiencies for LD-800 and IR-26 are considerably lower than that for Rd-590. Reference 5 quotes an observed lifetime of 22ps for IR-26 in dichlorethane. Combining this with our calculated value for the radiative lifetime (14.4 ns) yields a quantum efficiency of 0.2%. This agrees reasonably well into the quantum efficiency in Table 2 that we determined from the fluorescence measurements.

The measured LD-800 quantum efficiency of 8.6% may appear to be low. However, Raue et al.⁴ report that the quantum efficiency of LD-800 in ethanol is only 16%. Apparently methanol is also an efficient quencher. We recommend that more work be performed on LD-800.

The calculated A coefficients in Table 1 are the radiative rates for the respective singlet-singlet transitions of each dye. The quantum efficiency can be defined as the ratio of the observed decay rate/radiative rate. Note the observed decay rate depends upon the dye environment, e.g., the solvent, whereas the radiative rate is an inherent property of the dye molecule. Consequently the quantum efficiency also depends upon the environment.

Table 2 presents a summary of the fluorescence intensity measurements. In Table 2 we show the frequency representing the weighted average of the emission. In addition, we also present the calculated lifetime of the singlet state responsible for the emission. Finally we also present the measured values for the quantum efficiency of each dye. The quantum efficiency is defined as the ratio of fluorescence power/absorbed laser power. The quantum yield for Rd-590 is well known and we have compared the yields for LD-800 and IR-26 with that for Rd-590. This reduces possible systematic errors since all measurements were made using an identical geometry.

We note that we attempted to determine the fluorescence lifetime τ_0 using a pulsed dye laser as the excitation source. The dye laser pulse was ~ 15 ns and the rapid dye decay followed the decay of the laser pulse. Consequently, these measurements gave only an upper limit to the radiation lifetime. We feel that determination of τ_0 by the absorption method is

Table 2. Summary of Radiative Properties for the three dyes studied.

Dye	Solvent	n^2	$\int \frac{\epsilon_\nu d\nu}{\nu}$ ($\ell m^{-1} cm^{-1}$)	$\langle \bar{\nu}_f^{-3} \rangle^{-1}$ (cm^{-3})	τ_0 (ns)	Quantum Efficiency
RD-590	Methanol	1.77	9.2×10^3	5.4×10^{12}	3.9	95%
LD-800	Methanol	1.77	9.1×10^3	2.6×10^{12}	8.2	8.6%
IR-26	Dichloroethane	2.02	19.9×10^3	6.0×10^{11}	14.4	0.1%
*Literature value Ref. 6						

more reliable. A mode locked dye laser would be needed to measure lifetimes faster than a few ns.

From Table 2 we note that the quantum yields of Rd-800 and IR-26 are indeed quite high and are suitable dyes for diode laser excitation. The absorption coefficient measurements for Rd-800 demonstrate that a diode laser operating near 670 nm would be a good choice. For the IR-26 dye some of the 950 nm GaAs diodes would be the best match.

References

1. Stickler, S.J. and Barg, R.A., "Relationship Between Absorption Intensity and Fluorescence Lifetime of Molecule," J. Chem. Phys. **37**, 814 (1962).
2. "Kodak Optical Products" Eastman Kodak Co. and references contained therein.
3. Brackmann, W., "Lambdachrome Laser Dyes," Lambda Physik Catalogue (1986).
4. Raue, R. and Harnisch, H., "Dyestuff Lasers and Light Collectors -- Two New Fields of Application for Fluorescent Heterocyclic Compounds," Heterocycles **21**, 1 (1984).
5. Kopaxinsky, B., Qiu, P., Kaiser, W., Sens, B., and Drexhage, K.H., "Lifetime, Photostability, and Chemical Structures of IR Heptamethine Cyamine Dyes Absorbing Beyond 1 μm ," J. Appl. Phys. B **29**, 15 (1982).
6. Schaefer, F.P., "Dye Lasers," Topics in Applied Physics, Springer-Verlag, (1977).