

AD-A284 771

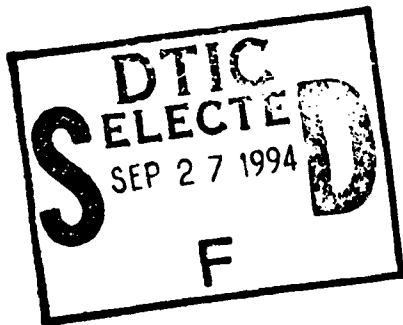

# THE DoD ENTERPRISE MODEL

## Strategic Activity and Data Models

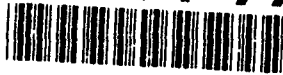

This document has been approved  
for public release and sale; its  
distribution is unlimited.

*23695* 94-30885

September 1994

DTIC QUALITY INSPECTED 3



Office of the Secretary of Defense, ASD (C<sup>3</sup>I)

94 9 27 06 8

# DRAFT SF 298

<b>1. Report Date (dd-mm-yy)</b> 09/94	<b>2. Report Type</b> SEMI-ANNUAL	<b>3. Dates covered (from... to )</b> January 94 to August 94			
<b>4. Title &amp; subtitle</b> THE DOD ENTERPRISE MODEL Strategic Activity and Data Models		<b>5a. Contract or Grant #</b>			
		<b>5b. Program Element #</b> 0901535D			
<b>6. Author(s)</b> Office of the Secretary of Defense, ASD (C3I)		<b>5c. Project #</b>			
		<b>5d. Task #</b>			
		<b>5e. Work Unit #</b>			
<b>7. Performing Organization Name &amp; Address</b> OASD (C3I) DASD (IM) 1225 Jefferson Davis HWY, STE 910 Arlington, VA 22202		<b>8. Performing Organization Report #</b>			
<b>9. Sponsoring/Monitoring Agency Name &amp; Address</b>		<b>10. Monitor Acronym</b>			
		<b>11. Monitor Report #</b>			
<b>12. Distribution/Availability Statement</b> Unclassified/Unlimited (U2)					
<b>13. Supplementary Notes</b> Field 25 should contain the identifier CIM (Collection), as detailed in A. Washington's, DTIC-OCS, IOM, dated 4/11/94.					
<b>14. Abstract</b> The DoD Enterprise Model is a critical element to the CIM Initiative. It is a key enabler for the senior leadership to understand their missions and functions, to plan and direct improvements from a DoD-wide perspective, and to measure all programs toward established goals. It is a representation of the activities and data of the entire Department currently needed to accomplish the Defense mission.					
<b>15. Subject Terms</b>					
<b>16. Report</b> U2	<b>17. Abstract</b> U2	<b>18. This Page</b> U2	<b>19. Limitation of Abstract</b>  Unlimited	<b>20. # of Pages</b>	<b>21. Responsible Person (Name and Telephone #)</b>  Lynne Sullivan OASD(C3I) DASD(IM) (703) 604-1567

# The Constitution of the United States of America

## Preamble

We the People of the United States, in Order to form a more perfect Union, establish Justice, insure domestic Tranquility, *provide for the common defense*, promote the general Welfare, and secure the Blessings of Liberty to ourselves and our Posterity, do ordain and establish this Constitution for the United States of America.

Accession For	
NTIS CRA&I	<input checked="" type="checkbox"/>
DTIC TAB	<input type="checkbox"/>
Unannounced	<input type="checkbox"/>
Justification .....	
By .....	
Distribution /	
Availability Codes	
Dist	Avail and/or Special
A-1	



COMMAND CONTROL  
- COMMUNICATIONS  
AND INTELLIGENCE

## ASSISTANT SECRETARY OF DEFENSE

6000 DEFENSE PENTAGON  
WASHINGTON, DC 20301-6000

September 2, 1994



MEMORANDUM FOR SECRETARIES OF THE MILITARY DEPARTMENTS  
CHAIRMAN OF THE JOINT CHIEFS OF STAFF  
UNDER SECRETARIES OF DEFENSE  
COMPTROLLER OF THE DEPARTMENT OF DEFENSE  
DIRECTOR, DEFENSE RESEARCH AND ENGINEERING  
ASSISTANT SECRETARIES OF DEFENSE  
GENERAL COUNSEL OF THE DEPARTMENT OF DEFENSE  
INSPECTOR GENERAL OF THE DEPARTMENT OF DEFENSE  
DIRECTOR, OPERATIONAL TEST AND EVALUATION  
ASSISTANTS TO THE SECRETARY OF DEFENSE  
DIRECTOR OF ADMINISTRATION AND MANAGEMENT  
DIRECTORS OF THE DEFENSE AGENCIES

SUBJECT: The DoD Enterprise Model

Attached is a copy of the Department of Defense (DoD) Enterprise Model that presents an integrated, top-level representation of DoD processes, information flows, and data. It provides you the Defense framework to use in conjunction with implementing DoD Directive 8000.1, "Defense Information Management (IM) Program." The Enterprise Model Volumes I and II have been consolidated into one document. The Model will be of particular assistance as you undertake efforts to simplify and streamline operations, re-engineer functional processes, and identify and validate process improvements.

I urge you to support the application of the principles contained in the DoD Enterprise Model and solicit your success stories on its application. Only through the use of a common model can we ensure a successful integration of functional processes and technical systems necessary to maintain military capability as we continue to downsize. Your staffs have contributed significantly to this document and will continue to do so through future updates.

Additional copies of the document may be obtained from the Defense Technical Information Center at (703) 274-7065. If you have any further questions or comments, you may contact Mr. Ron Oxley at (703) 604-1564 or Ms. Lynne Sullivan at (703) 604-1567.

  
Emmett Paige, J.

Attachment

## TABLE OF CONTENTS

TABLE OF CONTENTS	i
THE DoD ENTERPRISE MODEL	1
1. Background	2
2. Purpose of the Enterprise Model	3
3. Model Description and Concept	6
4. Using the Enterprise Model	11
5. The Activity Model	24
6. The DoD Strategic Data Model	55
APPENDICES	
A. The Activity Model	A-1
B. Activity Model Glossary	B-1
C. The DoD Strategic Data Model	C-1
D. Data Model Glossary	D-1
E. Core and Support End-to-End Processes	E-1
F. References	F-1
G. Comments	G-1

## THE DoD ENTERPRISE MODEL

The Department of Defense (DoD), at its most fundamental level, is charged with "providing for the common defense" of the United States. The President and the Secretary of Defense (SECDEF) establish the framework within which military and civilian plans, programs, and budgets are developed and the missions and activities of the Department are executed.

"Our goal is to make the entire federal government both less expensive and more efficient, and to change the culture of our national bureaucracy away from complacency and entitlement toward initiative and empowerment. We intend to redesign, to reinvent, to reinvigorate the entire national government."

President Clinton

"You should know that I am very serious about and deeply committed to the President's challenge to reinvent government. And I expect to see the Department of Defense not following the President and Vice President but leading."

Dr. William J. Perry  
Secretary of Defense  
Public Service Recognition Week  
4 May 1994

The President's *National Security Strategy of the United States* and the Chairman of the Joint Chiefs of Staff's *National Military Strategy of the United States* provide the context used to model the major activities of the DoD as an enterprise. The resulting DoD Enterprise Model is the basis for defining, coordinating, and integrating DoD missions and functions. It will enable the Department's leaders and managers to better understand and direct their areas of responsibility, and to integrate functional process improvement initiatives within and across functional and organizational boundaries.

## 1. BACKGROUND

"... 'There always comes a moment in time when a door opens and lets the future in.' For more than four decades the Defense Department has built its strategy and programs on dealing with the cold war. The ending of the cold war has opened a door, and the future is waiting to come in. By our actions, and by the new strategies we develop, we can shape the future, instead of being shaped by it."

Dr. William J. Perry  
Secretary of Defense

With the end of the Cold War and the increased emphasis on domestic issues, DoD is undergoing a downsizing and a redefinition of its missions, functions, and institutions. Senior officials in the Department must develop strategies for the 1990s and beyond that will result in greater effectiveness and efficiency in all defense activities. In particular:

- The defense community must be able to deal with a greater range of global and/or regional threats and challenges, in difficult environments, to achieve warfighting, peacekeeping, and humanitarian objectives.
- The US must have the strategic agility to respond rapidly and effectively to the new spectrum of worldwide missions, alone or with allies or coalition partners.
- Defense planners must accept greater risks, while taking new approaches to minimize potential adverse consequences.
- The US must maximize its use of scarce resources and focus on areas where the nation and its allies have a "competitive advantage" over potential adversaries.
- Greater interoperability, flexibility, effectiveness and efficiency must be ingrained in all defense activities, through continuous process improvements based on measurable goals.
- Better management practices must be applied across the Department, and continuous gains in mission-effectiveness, cost-efficiency, and contribution to national objectives must be integral to all defense activities.

- New methods, technologies, and tools must be brought to bear on defense needs in a timely, cost-effective manner. Defense, like other parts of the US government and industry, must smoothly and rapidly transition into the "Information Age."

The Corporate Information Management (CIM) initiative was established to provide senior leaders with the policies and mechanisms they need to achieve these goals. The CIM concept is to apply principles and practices proven in industry and government in the past decade to the defense challenge. Key principles that CIM promotes include:

- Top-down management of defense improvements from the senior leadership through all echelons to achieve national goals and objectives. This includes application of strategic planning practices within and across functions of the Department.
- Cross-functional and end-to-end integration of processes, data, and information systems to achieve greater interoperability, flexibility, efficiency, and effectiveness.
- Standardization of processes and practices across the Department, where this does not impair military operations.
- The application of process re-engineering and functional process improvement methods and tools successfully used in industry to manage major innovations and continuous cycles of improvement to cost, quality, timeliness, and productivity.
- The introduction of an "entrepreneurial" culture in the defense establishment, consistent with overarching national security objectives.
- Central guidance and direction of information systems development and services, using DoD-wide functional and technical architectures, standard data elements, and common methods and tools. An integrated, secure, reliable, and efficient defense information infrastructure will provide shared, cost-effective information services to the entire DoD.

## **2. PURPOSE OF THE ENTERPRISE MODEL**

The DoD Enterprise Model is a critical element in the overall CIM initiative. It is a key enabler for the senior leadership to understand their missions and functions, and plan and direct improvements from a DoD-wide perspective. From this, performance measures can be established based on process and outcome goals and linked into a unified DoD-wide functional

structure. These performance measures are mechanisms for evaluating functional goals and objectives. Until now, the Department has had to plan improvements on a function-by-function basis, with only limited ability to achieve cross-functional, enterprise integration and top-down strategic planning.

In the past, DoD functions and processes have often been managed from a narrow and parochial perspective. The results of this management approach are now seen in major discontinuities and "seams" that divide the Department:

- A sustaining base that is not fully capable of delivering supplies "just in time" to the Joint Task Force (JTF) — we cannot afford to provide support this way when our resources are dwindling and our responsibilities are growing worldwide.
- An intelligence system that is not fully capable of delivering pin-point targeting information to tactical commanders in the field, when and where they need it to strike the enemy — we cannot afford to deliver intelligence this way when we are faced with technically sophisticated, highly mobile, and ruthless adversaries.

These, and many other examples of "seams" in the fabric of DoD, show that management needs to take a new approach. The new DoD management paradigm is to take a defense-wide perspective, to see the "big picture" and focus effort where it delivers the most benefit to the entire enterprise. **DoD must remake itself into an integrated enterprise.**

The future integrated defense enterprise must be a globally interconnected network linked along all the dimensions of competency, capability, and resources. It must be able to channel and focus our nation's industrial strength, our power projection base, and our ready forces on crises, worldwide. To forge the links that will make this vision for the future become a reality, DoD leaders and managers need to have a shared, common understanding of all the activities and data in the enterprise — the DoD Enterprise Model provides this unified functional perspective. It is a conceptual map of the Department, on which we can find ourselves and the activities in which we participate.

Everyone, from the senior leader to the unit commander or the civilian branch chief, can locate where their activities and data fit in the DoD Enterprise Model:

- The model is holistic, so managers can see the total impact of changes to their processes and data on other processes and data throughout the Department.
- It is a shared "map" of the entire Department, so managers can communicate their concerns about potential gaps or duplications to other managers, no matter how far apart they are functionally or organizationally.
- It is a total picture of the Department, so senior leaders can find opportunities for defense-wide improvements and cross-functional linkages, and can target the initiatives that yield the highest Return on Investment for DoD.

The DoD Enterprise Model lets each of us position ourselves as part of the whole so we can work together, share resources, and add value to the defense mission. Every function and organizational element can map to the Enterprise Model, and identify its relationships with the rest of the Department.

In an organization as large, complex and interdependent as the DoD, changes in one process or function may have major "ripple effects" across the enterprise. The massive, Department-wide improvements now underway call for a disciplined management process to identify impacts and resolve issues. The Deputy Secretary of Defense has established an Enterprise Integration Executive Board (EIEB) and an Enterprise Integration Corporate Management Council (EICMC) as forums for the senior DoD leadership to work issues that arise from the accelerated selection of migration systems, standardization of data, and process reengineering. The DoD Enterprise Model is a critical tool for the Board and Council to use in identifying cross-functional and cross-Service impacts and opportunities. It is important to use this tool in all reengineering and improvement initiatives so that the Board and Council will have the information they need, in a common framework, to perform their activities.

"Each function and organization in DoD should utilize DoD Enterprise and Data Models to integrate PSA functional areas into the overall DoD-wide structure. This will provide a structured and greatly enhanced opportunity to discover disconnects and integration opportunities. The DoD Enterprise Model is a means for senior leadership to effect cross-functional and cross-organizational integration."<sup>1/</sup>

We want to stress that the Enterprise Model is a management tool. By itself, it will not result in cross-functional integration and defense-wide improvements. It relies on the actions of managers across the Department, at all levels, who believe that:

- their functions and organizations are parts of a larger defense-wide mission, and need to contribute to the vision, goals and objectives of the entire Department;
- open communication, using a unified functional framework, is the best way to identify and resolve issues; and
- integration and improvement is everybody's business, every single day.

The process inherent in the use of the DoD Enterprise Model is top down and disciplined. It begins with visible gaps and "obvious" needs for enterprise improvements and drives down systematically to programmed and implemented solutions. This volume presents the strategic level of the enterprise — the tip of the iceberg. Every organization in DoD needs to build the next levels down, using this evolving top-to-bottom DoD functional architecture to integrate improvements across the enterprise.

### **3. MODEL DESCRIPTION AND CONCEPT**

The DoD Enterprise Model is a guiding framework for all functions in the DoD. Each function performs a subset of defense activities to achieve its specific goals and objectives. The

---

<sup>1/</sup> Corporate Information Management for the 21st Century - A DoD Strategic Plan  
Assistant Secretary of Defense (Command, Control, Communications, and Intelligence (C<sup>3</sup>I)),  
June 1994, (issued by Deputy Secretary of Defense, 6 June 1994), p. 17.

Enterprise Model provides a common understanding of all defense activities and data for DoD leaders and managers, enabling them to integrate processes, data, and systems within and across missions and functions.

Figure 3-1 shows the DoD Enterprise Activity Model. Each function of the Department achieves its end-to-end objectives by participating in and contributing to four common DoD activities: **Establish Direction**, **Acquire Assets**, **Provide Capabilities**, and **Employ Forces**. Together, these four activities make up the DoD Enterprise.

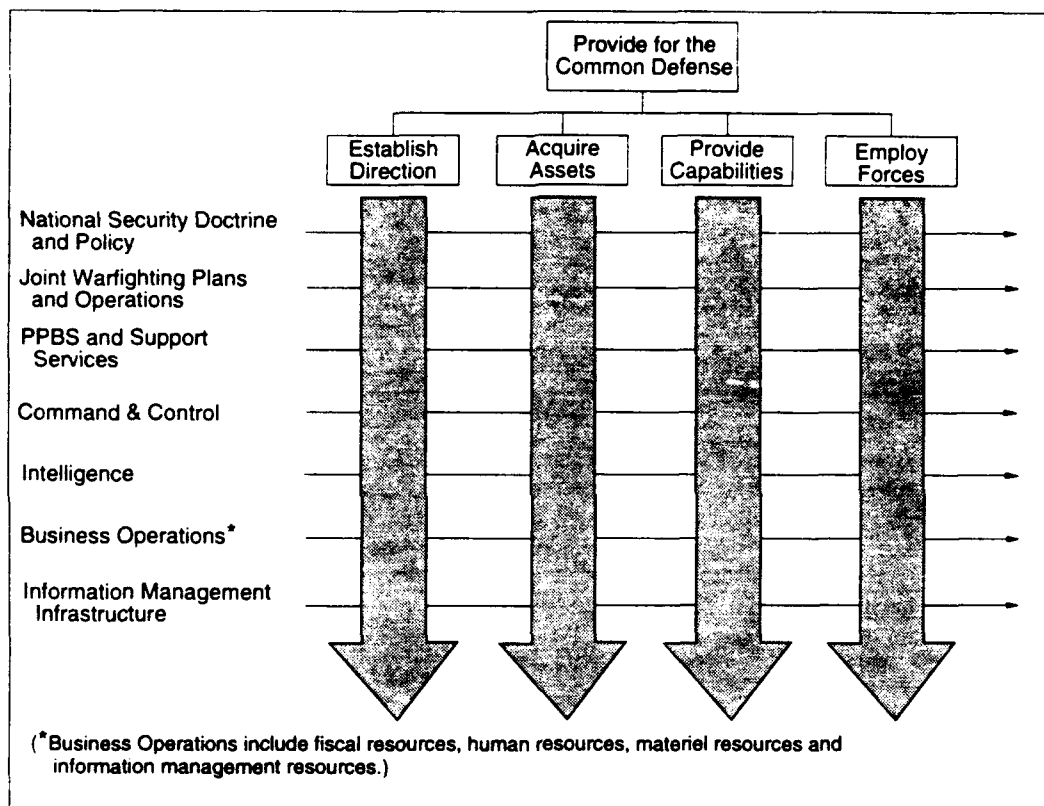

Figure 3-1. DoD ENTERPRISE ACTIVITY MODEL AND MAJOR DoD TASKS

- **Establish Direction:** provides the strategic vision, goals, objectives, policies, strategies, requirements, plans, and programmed resources that are executed in the other three activities.
- **Acquire Assets:** obtains the products, services, and people needed to accomplish defense missions.

- **Provide Capabilities:** integrates assets into organizations and units which are developed into ready capabilities to conduct missions and provides infrastructure support in peacetime, crisis, transition, and war.
- **Employ Forces:** uses forces to accomplish assigned operational missions, constitute the "bottom-line" delivery of capabilities to defend the nation, help keep the peace worldwide, and assist people in need as directed by the National Command Authority.

The DoD Enterprise Model consists of these four major activities and two additional levels of activity model detail. The DoD Strategic Data Model is the second key element for integrating the Department's functions and organizations. Figure 3-2 shows the strategic level data "buckets" that are the principal means by which senior leadership represents data-related priorities for guiding cross-functional integration of process improvement and data standardization opportunities. This data model is the basis for developing standard data elements that permit functional activities and organizations to communicate and work together.

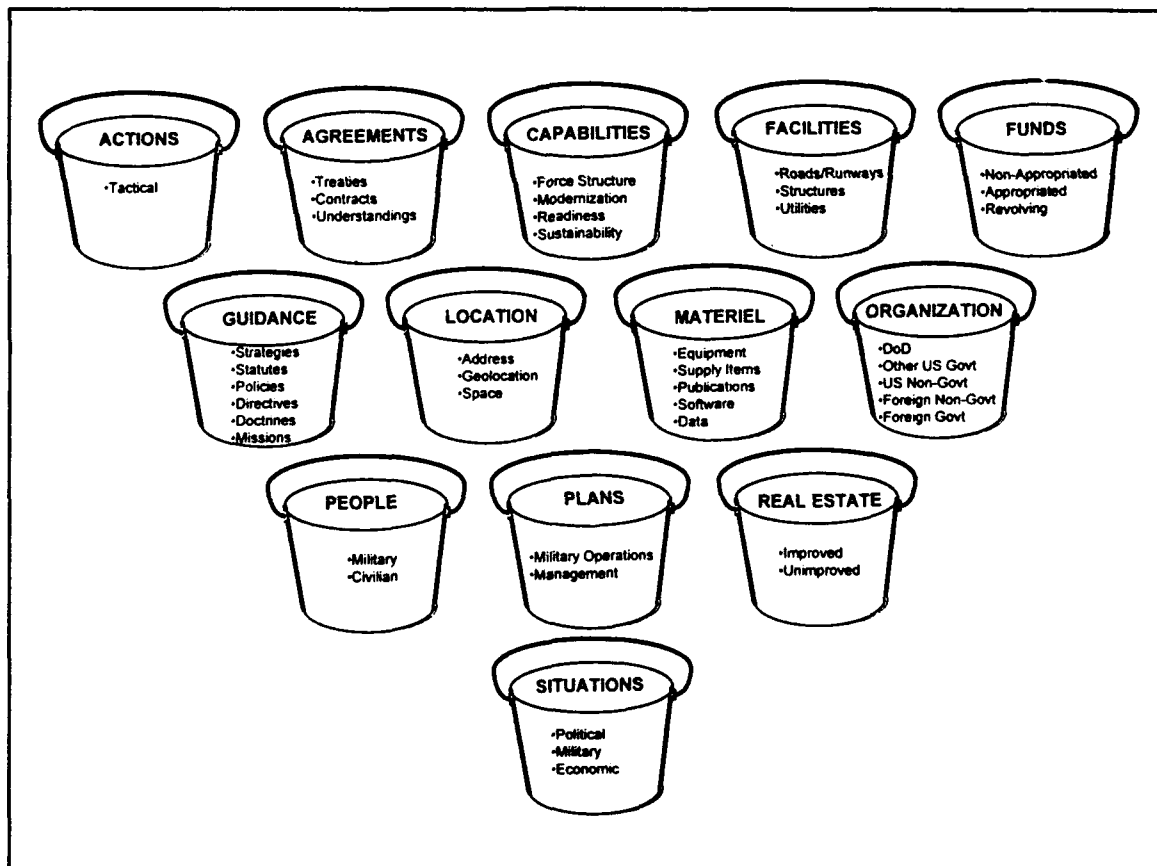

Figure 3-2. STRATEGIC LEVEL DATA BUCKETS

The Enterprise Activity and Data Models provide a common context and a template for all DoD functions and organizations. However, each function and organization has specific activities and data requirements. Therefore, the DoD Enterprise Model needs to be *tailored* for use by individual functions and organizations.

The Enterprise Activity Model is built economically and simply. With few exceptions, activities are described in only one place. However, some "similar" activities are described both for the sustaining base and for the Area of Responsibility (AOR). For example, transportation in CONUS and between theaters is described as **Transport** but, in the AOR, it is described as **Move**. In fact, while **Transport** and **Move** may be similar functions, they use different systems, and are often performed under different command/management. This highlights the "as-is" nature of the model, and how it can be used to find opportunities for process, data, and systems integration (e.g., between the sustaining base and the AOR). Also, in general, strategic management of functional areas and activities is described in **Establish Direction**, while tactical management of these functions is described in the other three major enterprise activities (e.g., **Manage Assets** provides specific assignments of assets to maintenance activities in **Provide Capabilities**).

The model was designed to be a universal framework for use by Principal Staff Assistants (PSAs), the Joint Chiefs of Staff (JCS), Commands, Services, and Defense Agencies. Therefore, the top-level processes are highly generic and are described in "plain English." This approach avoids confusion over terminology that obscures underlying commonalities in what is being done. Thus, different organizations can find a common meeting ground in the DoD Enterprise Model. They can identify the critical points of interaction between their activities, and can work to improve their processes and data as part of the defense team. The reader is asked to visualize many parts of the model "lighting-up" or "firing" simultaneously to accomplish each task. The model can be considered an "ignition harness" to get all the parts of the DoD engine running smoothly together. For example, mobilization is accomplished through an orchestrated, time-phased sequence of activities that transports units to mobilization stations, integrates and trains them, etc.

While this paper only shows the "strategic" level of the model, the DoD Enterprise Model conceptually includes all the activities and data comprising the national defense mission.

Over time, managers will develop models of their activities and data using the DoD Enterprise Model framework. These models will be integrated into the overall DoD Enterprise Model and will be centrally maintained in a DoD-wide library for common access. The ultimate goal is for functional managers to be able to have available a set of functional templates (i.e., building blocks) representing the evolving business and operational processes and data of the entire Department. The knowledge contained in this library will help managers at all levels to assess functional baselines and plan improvements from a DoD-wide perspective.

The DoD Enterprise Model is "owned" by the whole Department. Specific responsibilities for stewardship of its constituent elements are assigned in DoD policy. The success of the DoD Enterprise Model in helping the Department meet defense leadership goals and objectives is dependent on the commitment and dedication of functional proponents and stewards in fulfilling their enterprise-wide responsibilities.

The DoD Enterprise Model is the logical portrayal of activities and data to accomplish the defense mission, roles, and functions established in law and policy (e.g., Title 10, US Code). The DoD Enterprise Model is a baseline or "as-is" model. It highlights discontinuities, gaps, and areas for improvement. For example, the model helps leaders and managers to understand that:

- Sustaining base support that is described in **Provide Capabilities** needs to be integrated seamlessly with combat service support to the forces in the AOR described in **Employ Forces**.
- The acquisition of weapons, supplies, and other assets described in **Acquire Assets** must satisfy the needs of Commanders-in-Chiefs (CINCs) and Joint Task Force Commanders who **Conduct Operations**.
- The ultimate effectiveness and efficiency of the overall defense mission is determined by how well **Establish Direction** sets policy, determines requirements, plans, and allocates resources needed to **Acquire Assets**, **Provide Capabilities** and **Employ Forces**.

The use of the model as part of the on-going re-examination of Department activities will result in a new leadership vision for defense which will be articulated through the evolving DoD Enterprise Model.

#### 4. USING THE ENTERPRISE MODEL

The DoD Enterprise Model serves as a context and template for individual enterprises across the Department to model their functions and organizations. Individual "enterprises" within DoD can provide views of the Enterprise Model that enhance its utility for managing their activities and data while maintaining its integrity as a common DoD baseline.

##### 4.1 INTEGRATION OF FUNCTIONAL MODELS INTO THE ENTERPRISE MODEL

PSAs and Functional Activity Program Managers apply functional process reengineering to their areas and activities. In general, reengineering is approached from a top down, strategic perspective. Figure 4-1 shows the broad concept for using the DoD Enterprise Model in conjunction with functional process reengineering to achieve the optimum return on investment for DoD as a whole, and enterprise-wide integration.

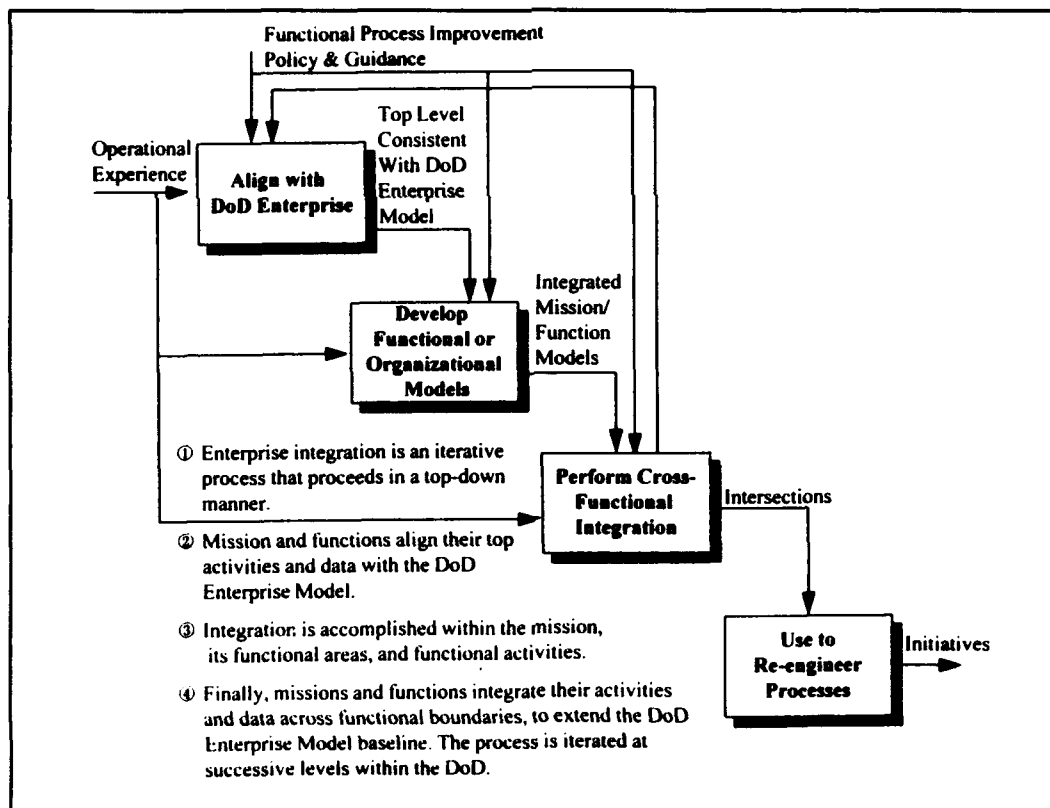

Figure 4-1. MODEL INTEGRATION

**Align Functions and Organizations with DoD Enterprise.** Each functional area or functional activity can be mapped to the DoD Enterprise Model by identifying the model activities that are relevant to the functions and the data that are needed to support them. In addition to purely functional models, organizations can develop models of the processes they perform. These should be developed so they are consistent and integrated within Departmental organizational structures.

**Develop Functional and Organizational Models.** Once functional managers or organizations identify relevant Enterprise Model activities and data, they tailor and refine it to meet individual functional requirements. In general this means adding ICOMs (inputs, controls, outputs, mechanisms), decomposing activities, and refining the data models. It may also include creating a "view" that more directly captures the "specifics" of a community or audience; for example, tracking a weapon system through **Acquire Assets**.

**Perform Cross-Functional Integration.** Functional areas, activities, and organizations, integrate with other enterprise functions and organizations using the DoD Enterprise Model as a framework to find points of interaction, to define functional relationships, to establish standard data interfaces, and identify common systems. This ensures maximum synergy across the Department and avoids duplication.

**Use the Functional/Organizational Models to Reengineer Processes.** These models are used to identify high payoff/high impact processes to be selected for elimination, redesign or incremental improvement. This approach is applied at successive levels in DoD so that leadership can guide reengineering to achieve strategic goals and objectives.

#### **4.1.1 Data Models and Data Standards**

In an integrated enterprise, commanders and managers must share a common understanding of activities. This strategy ensures consistency, quality, timeliness, availability and security of shared enterprise data by implementing enterprise databases using standard data elements as soon as possible. While activity models should be as consistent as possible, data models and data elements must be standardized in accordance with DoD Data Administration procedures (see DoD 8320.1-M-1). **Data standards provide the "glue" that integrates**

**functions across the Department.** Activities will be able to use shared standard data so they can work together to achieve common objectives.

#### **4.1.2 Support and Management**

The DoD Enterprise Model is an essential element of the functional process improvement initiative and the data administration program of the DoD. It is managed as a corporate resource that serves all functions and organizations in the Department.

The management structure for functional process improvement is provided in DoD 8020.1-M. Integrating the enterprise is everyone's responsibility, from the Secretary of Defense to the individual defense worker. The process of integrating the enterprise has functional, technical, and management elements. The Office of the Assistant Secretary of Defense (C<sup>3</sup>I) (OASD (C<sup>3</sup>I)) works closely with the responsible PSAs, the JCS and their functional managers to facilitate this process. The EIEB and the EICMC identify and resolve cross-functional issues arising out of the accelerated implementations of migration systems, data standards, and process improvements. These forums also review opportunities for cross-functional integration.

Functional and organizational models, developed within the enterprise framework, will physically reside in the DoD Repository System. Furthermore:

- As the individual parts of the Department develop activity models and data models to support functional process improvement and data administration, these models will be used to refine and extend the DoD Enterprise Model. The models are reviewed and approved by PSAs and their staffs for functional adequacy, DISA for technical adequacy, and are reviewed and approved by OASD (C<sup>3</sup>I) for consistency with the DoD Enterprise Model.
- Once functional activity and data models are developed and approved, they become a part of the DoD Enterprise Model. The entire Department has access to these models. They provide a baseline for specifying functional and systems interfaces, identifying and evaluating the impacts of changes to one function or other functions, and developing improved processes and data structures.
- Through analysis of the evolving DoD Enterprise Model, the functional leadership of the Department, Functional Integration Managers, the DoD Data Administrator, and others will identify and resolve issues that cross functional area boundaries, and look for opportunities to integrate processes, data, and information systems to achieve DoD-wide objectives.

This will lead to greater interoperability, flexibility, effectiveness and efficiency across the DoD.

## **4.2 APPLICATION OF THE ENTERPRISE MODEL**

This section provides a practical, step-by-step guide for using the DoD Enterprise Model in functional process improvement (FPI) efforts. By displaying all major top level DoD activities in a single model, the strategic level of the Enterprise Model enhances the ability of all DoD personnel and activities to conduct effective FPI and related CIM efforts within a Departmental context while maximizing the value of individual efforts to the DoD as a whole. This section describes how to extend the applicability and usefulness of the Enterprise Model to operational levels.

Once an organization can see itself in relation to other DoD organizations and activities, it can better understand the influences affecting its activities as well as its impacts upon other organizations. Determining and understanding these relationships provides the basis for linking policy, business methods, processes, performance measures, data, information systems, and the computing and communications infrastructure. This approach allows organizations to achieve cross-functional and cross-organizational end-to-end process integration.

Effective use of the Enterprise Model necessitates the understanding that conceptually the model represents the top level activities and data structures of the DoD. The majority of activities in the Department require elements of planning, programming, budgeting, and some form of execution. The highest level activity nodes described earlier illustrate this point.

In short, **Establish Direction (A1)** incorporates the planning, programming, and budgeting functions while **Acquire Assets (A2)**, **Provide Capabilities (A3)**, and **Employ Forces (A4)** are "executing" functions.

### **4.2.1 A Methodology for Using the Enterprise Model**

The DoD Enterprise Model should be used in all FPI efforts. This section describes the logical steps for using the DoD Enterprise Model as a framework for functional managers or organization elements modeling their processes. Table 4-1 summarizes the seven-step methodology described next. This methodology relates the use of the Enterprise Model to the

CIM Functional Process Improvement procedures. An illustrative example of the methodology is included at the end of the section.

Step 1.	Determine Strategic Framework and Policies
Step 2.	Locate Activity Within the DoD Enterprise Model
Step 3.	Identify and Contact Interfacing Organizations
Step 4.	Document Baseline and Build Activity and Data Models
Step 5.	Analyze Baseline Results, Assess Improvement Opportunities, and Develop TO-BE Models
Step 6.	Develop Implementation Plan
Step 7.	Share Results and Incorporate Models in DoD Repository System

Table 4-1. METHODOLOGY FOR USING THE DoD ENTERPRISE MODEL

***STEP 1. Determine Strategic Framework and Policies***

Determine the major DoD function(s) and process(es) being addressed by the effort. Functional managers may identify the parts of the DoD Enterprise Model that are relevant to their functional area or activity.

Identify the customers, consumers and suppliers for products and services produced by the function. Customers include the President, Congress, SECDEF, the Services, and support commands. The combatant CINC is the critical defense consumer. Suppliers for the defense mission include the Defense Agencies, the Services, private industry, other government agencies, host nations, allies, and supporting CINCs.

Define strategic direction for the function or process(es). This involves establishing a mission, vision, goals, objectives, performance measures, current situation and strategies. Higher level guidance and direction (e.g., the Defense Planning Guidance and existing policies) should be used in developing a strategic plan that provides direction for the function or processes to be modeled.

***STEP 2. Locate Activity Within the DoD Enterprise Model***

Review the Enterprise-level activities, functions, and processes for DoD identified in the DoD Enterprise Activity Model.

Identify in the model, the processes for which the functional manager holds primary responsibility. For example, functional managers responsible for depot maintenance would locate their activity in the Enterprise Model under **A3.2.1 Maintain**. At the same time, there are other inherent activities (e.g., planning, programming, budgeting, procuring) which must be performed to provide depot maintenance capabilities. Such processes should be located in **A1 Establish Direction** or elsewhere in the model. All managers should be able to locate the processes they are responsible for within each of the high level activity nodes - **Establish Direction, Acquire Assets, Provide Capabilities, and/or Employ Forces**.

***STEP 3. Identify and Contact Interfacing Organizations***

Identify and contact other managers/organizations with an interest or with an interface/dependency with the function or activity. Working closely with these managers/organizations throughout the improvement efforts, to optimize and integrate results for the DoD as a whole. The PSA and functional manager can assist in identifying similar efforts in the appropriate functional areas. PSAs and functional managers responsible for coordination of CIM improvement efforts will be able to provide points of contact with which to coordinate on business process reengineering (BPR) and other improvements to data, migration systems, and infrastructure.

***STEP 4. Document Baseline and Build Activity and Data Models***

Conduct modeling efforts to document the current (AS-IS) baselines for both the activity and data models. In Step 2 above, all relevant processes, activities, and functions were identified and located in the DoD Enterprise Model. The identified activity nodes of the Enterprise Model should be used as templates for developing the AS-IS models by adding ICOMs, decomposing activities, etc. This speeds the development of functional area models. The models should depict a lower level of detail while still maintaining the framework of the high-level Enterprise Model.

***STEP 5. Analyze Baseline Results, Assess Improvement Opportunities, and Develop TO-BE Models***

Analyze the AS-IS model and decide on areas of improvement, innovation, and elimination.

Research and obtain information from benchmarking sources on best business practices, and gain insight from on-going improvement initiatives and alternatives.

Develop TO-BE models of future functional processes by considering all options ("thinking out of the box") and applying best practices obtained by benchmarking. New processes should be designed to reflect improvements facilitating integration with other organizations and processes.

***STEP 6. Develop Implementation Plan***

Analyze the current state of operations (the AS-IS baseline) and the new designs embodied in the TO-BE model.

Develop an implementation plan, to establish a roadmap to transition from the AS-IS state to the TO-BE target. The implementation plan should include a timeframe in which the transition will be accomplished, the organizational responsibilities for achieving the objectives, and the resources required.

Coordinate with related activities to reconcile implementation plans which impact on the targeted process.

***STEP 7. Share Results and Incorporate Models in DoD Repository System***

Provide completed activity and data models to appropriate sponsors and functional managers. All activity and data models should be reviewed and approved by a PSA before being incorporated into the DoD Activity and Data Repository.

Incorporate models into the repository system. The DoD Repository System is the vehicle that maintains the DoD Enterprise Model and provides the entire Department with access to these models. The models establish a baseline for specifying functional and systems interfaces, for identifying and evaluating impacts of changes to one mission or function on other missions and functions, and for developing improved processes and data structures.

**4.2.2 An Illustrative Example**

The following is an *ILLUSTRATIVE* example of the potential use of the model. For the sake of realism, a specific function, logistics, was selected. However, the example does not necessarily represent current efforts in the logistics community. The example illustrates only the generic approach; therefore, actual logistics improvement initiatives may not reflect the concepts in the example.

The logistics functions of the Department cut across all four major activities in the DoD Enterprise Model. Figure 4-2 shows how the DoD "logistics enterprise" could be aligned with the DoD Enterprise by applying the DoD Enterprise Model as described in Steps 1 and 2 above.

<i>Establish Direction</i>	<i>Acquire Assets</i>	<i>Provide Capabilities</i>	<i>Employ Forces</i>
Establish Military Logistics Policy	Manage Acquisition of Logistics Assets	Manage Logistics Assets & Services	Constitute Logistics Capability in AOR
Determine Logistics Requirements	Research/ Design Logistics Infrastructure	Provide Maintenance, Repair, etc. (CONUS)	Provide Operational Intelligence
Plan Logistics	Produce Logistics Assets & Services	Administer Logistics Infrastructure	Conduct Operations
Program/ Budget Logistics		Train Logistics Units & Organizations	Conduct Combatant Operational Logistics

Figure 4-2. "LOGISTICS ENTERPRISE" ALIGNED WITH DoD ENTERPRISE  
(Shaded boxes are not logistics functions)

In Step 3, the major organizations involved in improving the logistics enterprise are identified and form "partnerships for change."

- The strategic direction for logistics is established by OSD, JCS, Commands, Services and Defense Agencies. (A1: Establish Direction) A DoD Logistics Strategic Plan (or several coordinated plans) provides the vision, goals, objectives and measures of performance for defense logistics activities.
- Logistics assets, including supplies, facilities (e.g., depots), and transportation capacity are acquired by the Services and Defense Agencies. (A2: Acquire Assets)

- Sustaining base logistics is provided by the Services and Defense Agencies. Transportation and supply are critical elements of US power projection capabilities. (A3: Provide Capabilities)
- Theater/AOR and combat service support logistics is provided by the Services and Defense Agencies in coordination with and under operational control of the CINC and JTF Commander. (A4: Employ Forces)

Step 4 documents the existing baseline and begins analysis on the current situation. Figure 4-3 and Figure 4-4 (on the next page) show two example AS-IS models of key process chains in the current logistics functional baseline. The first set of processes provides wholesale and intermediate logistics. The second set of processes provides power projection and combatant logistics.

In Step 5, an assessment of the current situation shows a disconnect, or "seam," between these critical components of the DoD Enterprise. But, by placing the processes in a broader DoD-wide context (i.e., that provided by the DoD Enterprise Model), functional managers can plan improvements that will integrate functions, data, and information systems to provide seamless, "industry to foxhole" logistics support for the JTF combatants.

Figure 4-5 (on page 21) shows, from an enterprise perspective, a candidate future end-to-end logistics capability (a TO-BE model) that delivers supplies and equipment to the combatant commanders and forces in the field, when and where needed, worldwide, to accomplish assigned missions.

In Steps 6 and 7, a DoD-wide collaborative effort would be needed to realize such a future end-to-end capability. The various players identified previously in Step 2 would need to work together to implement and realize these changes.

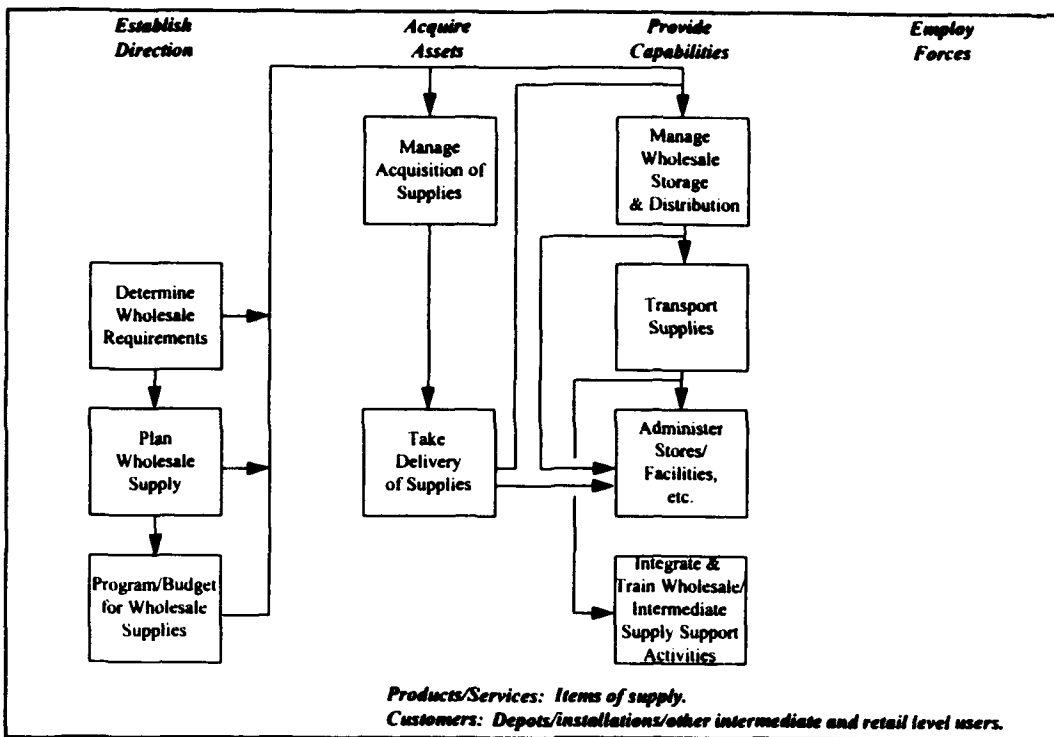

Figure 4-3. EXAMPLE "WHOLESALE/INTERMEDIATE" END-TO-END PROCESS FOR DoD SUPPLY

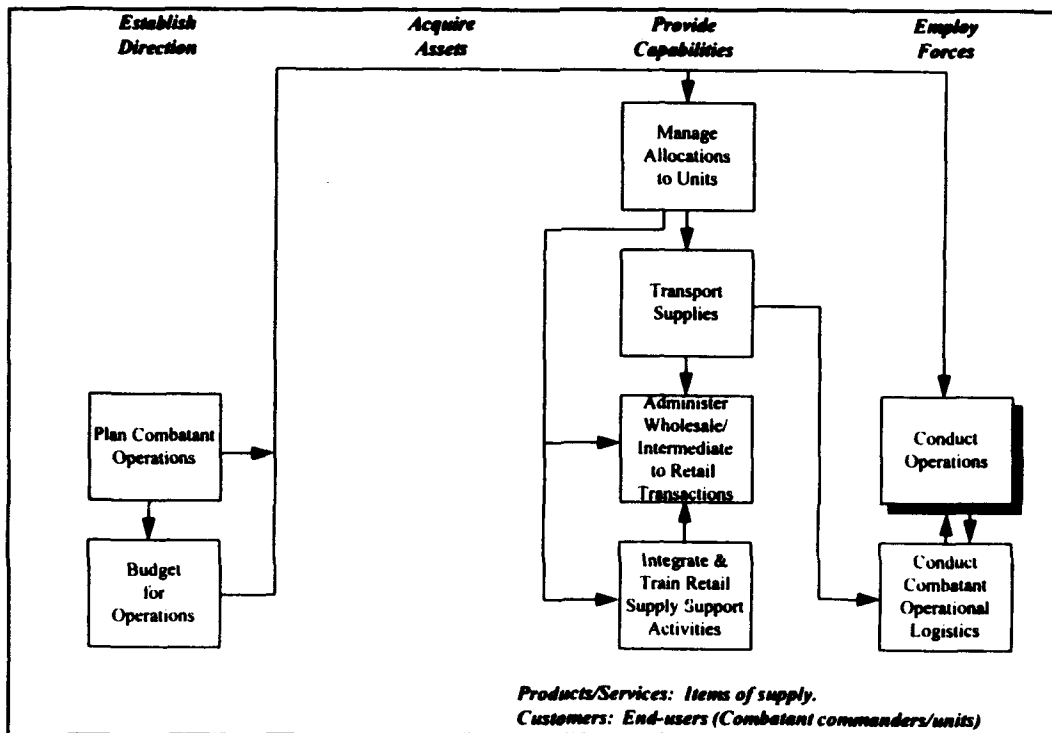

Figure 4-4. EXAMPLE "RETAIL" END-TO-END PROCESS FOR SUPPLY

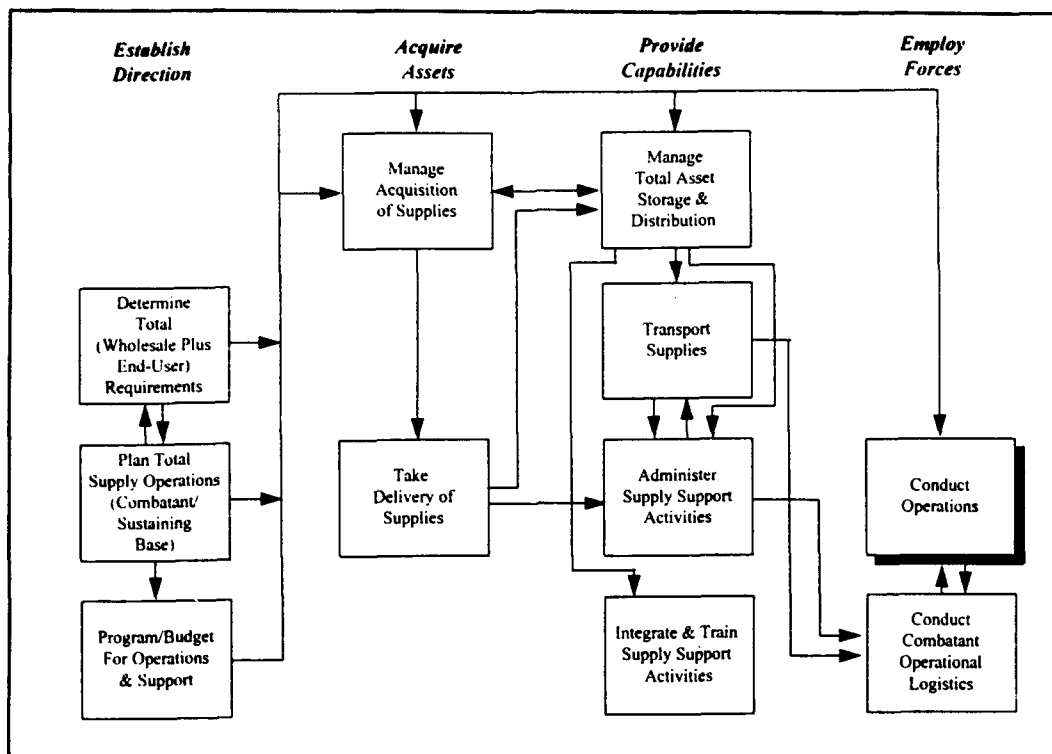

Figure 4-5. EXAMPLE "END-TO-END" TOTAL SUPPLY PROCESS FOR DoD

In summary, the DoD Enterprise Model has been used in this example to illuminate key deficiencies and opportunities:

- Examining the processes and links in the total logistics "value-chain" — the "logistics enterprise" for peace, crisis, and during/post operations — OSD and JCS would determine a roadmap to reach logistics goals and measures of performance that support the National Military Strategy and the DoD Logistics Strategy. The roadmap would consist of major initiatives and thrusts, such as Total Asset Visibility, to guide more specific programs and projects. This top-level strategic reengineering is essential to focus effort on high payoff/high impact changes to processes, data, and systems from a DoD-wide perspective. These high payoff/high impact areas would be identified through an analysis of the entire logistics enterprise, yielding concepts and principles that can guide specific improvements. For example:
  - Host-nation/friendly-nation logistics support reduces the burden on US infrastructures. This requires compatibility/availability of items of supply and interoperability of systems with our allies and coalition partners.

- Management in the theater (theater-wide and by CJTF), should be integrated with "wholesale/intermediate" level management. This also involves integration with the acquisition of supply contracts to ensure their availability and suitability to the supply concept.
  - Business methods (e.g., DBOF and appropriated funds) need to be standardized and meshed across the entire process chain. There should be a smooth transition from charge-push to demand-pull allocation schemes.
  - Total Asset Visibility (TAV) crosses all major Enterprise activities. This is particularly true for central elements of supply (e.g., special ammunitions and equipment spares). Linkages of data and systems must be built from the national level down to the JTF headquarters and below to implement the overarching goal.
  - Data and systems need to be integrated to strengthen links from industry suppliers to distribution points, to the JTF and below to ensure a rapid, smooth flow of orders, end-to-end tracking and control. EC/EDI applied across the value chain can facilitate this objective.
- The Services and Defense Agencies would implement the strategic vision and goals of the defense leadership in programs and projects that achieve logistics enterprise objectives and measures of performance. Various organizations would develop specific improvement initiatives, programs and budgets. These initiatives would be assessed for their adequacy to meet strategic priorities, and balanced within available resources.

The strategic vision and goals established by DoD senior leaders would be implemented through specific initiatives undertaken by different organizations. On the following page, we illustrate this with example goals (Table 4-2) and specific examples using two hypothetical individual initiatives (Table 4-3) that implement the overarching goal but from a different perspective. The first initiative would be focused on the wholesale to retail level using direct delivery from the industry supplier to retail level users. The second initiative would be focused on supplying critical items to the combatant units efficiently.

Putting these initiatives in the overall context of the Enterprise Model and the logistics "view" shown earlier in Figure 4-2 can help integrate the two individual initiatives and establish

a "seamless," cost effective, end-to-end logistics chain from industry to the "foxhole," that achieves major improvements in logistics response time and greatly lower unit costs.

**Overarching Goal:** Provide reliable, flexible, cost-effective, and prompt logistics support information and services.

Goal #1. Develop a seamless logistics system.

Goal #2. Reduce logistics response times.

Goal #3. Reduce the cost and "footprint" of the DoD logistics infrastructure.

Table 4-2. EXAMPLE STRATEGIC GOALS FOR END-TO-END CAPABILITY

**Initiative #1:**

Send purchase orders from central supply points to industry sources. Have industry sources ship directly to receiving retail units in CONUS or depots. Use DBOF funding mechanisms. Centrally manage integrated supply points (ISPs). Apply EC/EDI.

**Initiative #2:**

Aggregate supply item requisitions/orders at JTF headquarters and CINC headquarters (2-levels). Allocate JTF/Theater assets centrally. Pass additional requirements to national-level central supply managers for fulfillment.

Use Service appropriated funds mechanisms. Manage supply classes centrally (Joint supply management under CJTF and CINC).

Table 4-3. EXAMPLE INITIATIVES

### **4.3 CONCLUSION**

The Enterprise Model allows all the players to see the big picture as they apply the FPI process. The objective is to avoid narrow perspectives and parochialism. Developing strategic direction and "fitting" individual initiatives into a DoD enterprise-wide context, helps promote a dialogue between all the functional managers, military staffs, and industry suppliers focused on DoD-wide solutions. In this sense, the DoD Enterprise Model is most importantly a way to bridge cultural, organizational, and individual viewpoints to reach shared visions and goals.

### **5. THE ACTIVITY MODEL**

The activities described on the next several pages capture the essence of the DoD Enterprise Model. To gain an immediate overview of the whole model, an executive-level display is contained on the following pages. The numbering scheme used on the display and in the text matches the identifiers used in the detailed model graphics and text contained in Appendix A.

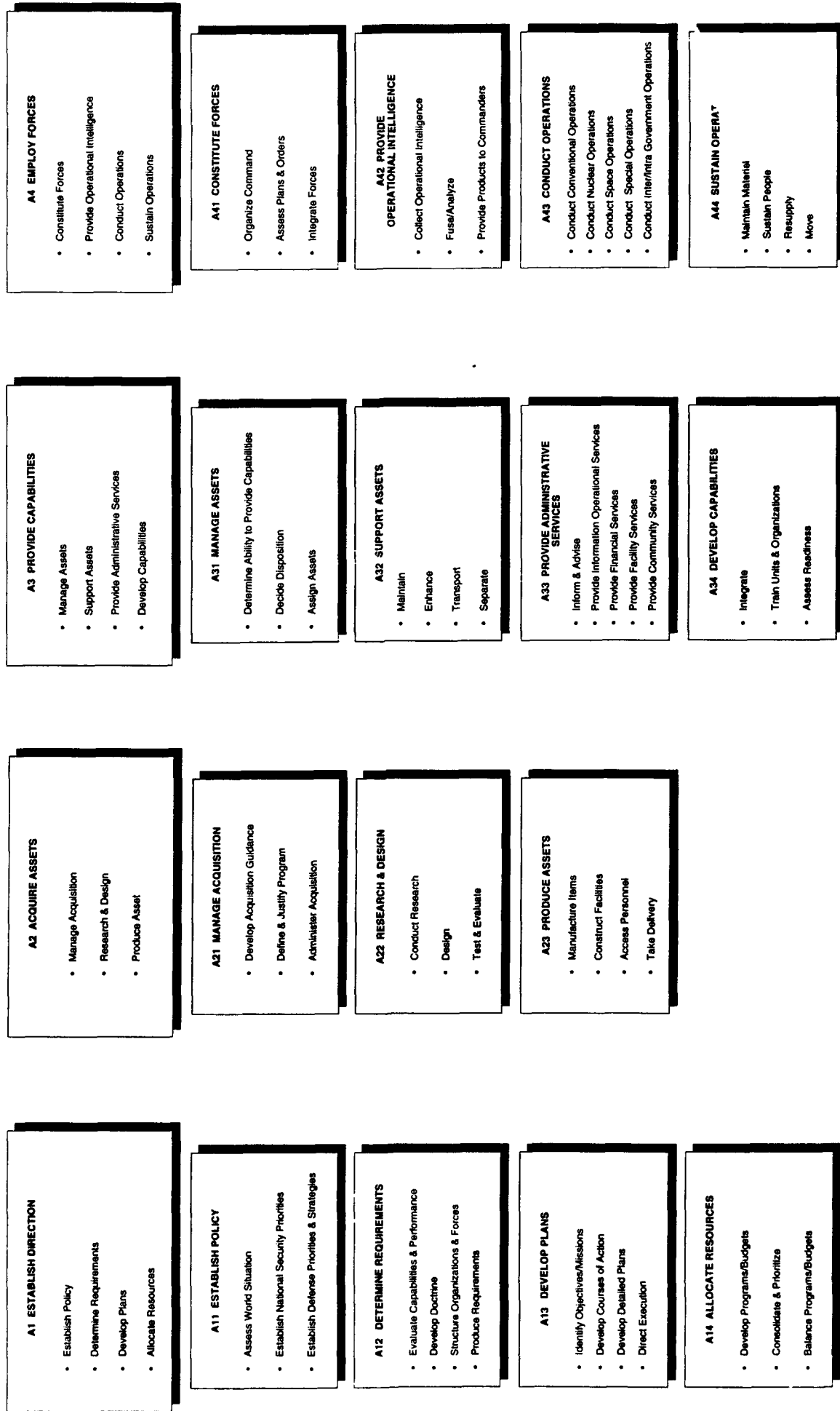

Figure 5-1. THE DoD ENTERPRISE MODEL

## A1 ESTABLISH DIRECTION

### ESTABLISH DIRECTION

- Establish Policy
- Determine Requirements
- Develop Plans
- Allocate Resources

This major activity of the defense enterprise establishes the mission, goals, objectives, strategies, requirements, plans, and resources for the Department of Defense (DoD). National security interests, developed to be consistent with and in support of national values and priorities, are integrated into defense policy, guidance, plans, and programs. There are four activities in **Establish Direction**:

**Establish Policy** assesses the world situation for threats to peace and welfare, establishes the national security strategy of the United States, and establishes defense priorities and strategies that guide and direct the definition of requirements, development of plans, and allocation of resources within the DoD. The context for the National Security Strategy and the National Military Strategy is established through the interaction of the Executive Branch — to include the DoD, Department of State, Central Intelligence Agency, and the Office of Management and Budget — and the Congress and the Judicial Branch.

**Determine Requirements** assesses the actual capabilities of the US, as demonstrated by the performance of forces in action and the outcomes of defense programs. As a result of this assessment, deficiencies in the current defense baseline are identified. Opportunities to improve doctrine, force structures, other organization capabilities, and assets (e.g., weapons, people) are analyzed for their suitability and realism. The requirements for modernization, force structure, sustainment, and readiness are determined through this activity.

**Develop Plans** develops military plans and resource/management plans within the context of the Joint Strategic Planning System (JSPS) for warfighting plans, and the Planning, Programming, and Budgeting System (PPBS) for resources. All plans of the Department are

#### ESTABLISH DIRECTION

- Establish Policy
- Determine Requirements
- Develop Plans
- Allocate Resources

*Continued*

produced in this activity, based on civilian and military requirements. Conversely, planning generates new requirements and impacts on policy (e.g., determines the limits of policy).

**Allocate Resources** develops resource needs into programs submitted as Program Objective Memoranda (POMs). Resource needs are consolidated to align timing, eliminate duplication, and establish integrated priorities. The Defense Planning and Resources Board (DPRB) reviews issues and determines a final position in the Budget Estimate Submission (BES) which is incorporated in the Defense Budget. The Defense Budget is submitted as part of the President's Budget to Congress for authorization and appropriation.

### A11 Establish Policy

#### ESTABLISH POLICY

- Assess World Situation
- Establish National Security Priorities
- Establish Defense Priorities & Strategies

This activity assesses the world situation for threats to peace and welfare, establishes the National Security Strategy and the National Military Strategy of the US, and establishes defense priorities and strategies that guide and direct the definition of requirements, development of plans, and allocation of resources within the DoD. The context for the National Security Strategy and the National Military Strategy is established through the interaction of the Executive Branch — to include the DoD, Department of State, Central Intelligence Agency, and the Office of Management and Budget — and the Congress and the Judicial Branch. There are three activities in **Establish Policy**:

**Assess World Situation** monitors global and regional situations for actual and potential threats to US interests and goals. Indications and warnings are tracked, and national intelligence assets are ordered to focus on specific situations, events, and areas of concern to the National Command Authority (NCA). Political, economic, and military information is gathered, fused, and analyzed to determine trends, estimate intentions,

#### ESTABLISH POLICY

- Assess World Situation
- Establish National Security Priorities
- Establish Defense Priorities & Strategies

*Continued*

and assess the capabilities of adversaries. Natural and manmade disasters, terrorist actions, international drug trafficking activities, and civil disorders are closely followed and their significance to US interests is assessed.

The status and location of US forces and resources are monitored to provide the NCA and military commanders with a reliable, timely understanding of US capabilities, as well as to comply with Congressional reporting requirements and public law. Status reporting is increased, as necessary, in crisis and war. This activity also continually tracks global weather, terrain, and oceanographic conditions.

**Establish National Security Priorities** develops national security priorities, goals, and strategies based upon US interests, expectations of the world community, agreements, and the world and domestic situation. The defense leadership, through the Secretary of Defense and the Chairman of the Joint Chiefs of Staff (JCS), participate in formulation of national security policy by providing advice and counsel relating to military threats, strategic military options, US and allied/coalition capabilities, and risks. National security concerns in the post-Cold-War era include maintaining international peace and order, ensuring economic security, promoting and securing democracy around the world, preventing proliferation of weapons of mass destruction, countering international terrorism and drug dealing, and preserving the global environment. Also, the US and the world community are increasingly providing humanitarian help and disaster relief to people in need, in circumstances that require the use of military forces to deliver assistance.

This activity integrates legislative requirements and statutory programs mandated by Executive, Judicial and Congressional authorities into defense guidance (e.g., acquisition regulations). International agreements (e.g., alliances and host-nation support), emergency authorities (e.g., for

### ESTABLISH POLICY

- Assess World Situation
- Establish National Security Priorities
- Establish Defense Priorities & Strategies

*Continued*

mobilizations), and political/military/economic constraints are established. The National Security Strategy of the US and the National Security Decision Directives are the top-level guidance that result from this activity.

**Establish Defense Priorities & Strategies**, led by the Secretary and Chairman, responds to national security guidance by developing global and regional military missions, strategic vision, goals and objectives, and measures of performance; preparing, assessing and recommending strategic military options; specifying major missions for the DoD (e.g., deterrence, peacekeeping); recommending required host-nation support; assessing US capabilities and needs; and generally advising the NCA and the Congress on military matters. The National Military Strategy of the US is produced from this activity. Defense Planning Guidance (DPG) is issued by the SECDEF to guide requirements and planning activities (see below). Subordinate elements of the Department issue guidance for their areas of responsibility consistent with the DPG.

## A12 Determine Requirements

### DETERMINE REQUIREMENTS

- Evaluate Capabilities & Performance
- Develop Doctrine
- Structure Organizations & Forces
- Produce Requirements

This activity assesses the actual capabilities of the US, as demonstrated by the performance of forces in action and the outcomes of Defense programs. As a result of this assessment, deficiencies in the current defense baseline are identified. Opportunities to improve doctrine, force structures, other organization capabilities, and assets (e.g., weapons, people) are analyzed for their suitability and realism. The requirements for modernization, force structure, sustainment and readiness are determined through this activity. There are four activities in **Determine Requirements**:

**Evaluate Capabilities & Performance** assesses the actual performance of the Department against the threat and national objectives in order to determine overall requirements for improvement.

#### DETERMINE REQUIREMENTS

- Evaluate Capabilities & Performance
- Develop Doctrine
- Structure Organizations & Forces
- Produce Requirements

*Continued*

DoD policy is to re-engineer and continuously improve its methods, processes, data, and information systems. At all levels the outcome of defense activities — operational experience — is evaluated to determine success or failure. After-Action Reports (AARs) are used to generate lessons learned from operations in the field. For peacetime exercises, force performance is measured against training standards. Resource and management programs that require assets and provide support capabilities are also assessed against established goals and metrics. These evaluations are the feedback needed to improve the defense activity. They are disseminated to commanders, managers, and analysts to affect policies, doctrine (strategic, operational, and tactical), force structures, unit/organizational training methods and measures, materiel, personnel, and systems requirements. Mission Need Statements (MNS) identify capability deficiencies and unmet requirements.

**Develop Doctrine** examines current doctrine and evolves improved doctrine and procedures. Joint Pub 1, *Joint Warfare of the US Armed Forces*, issued by the Chairman of the Joint Chiefs of Staff, sets the doctrinal stage for integrating service units into effective joint fighting forces. Nested within joint warfighting doctrine are the Service doctrines for common and unique functions. Potential doctrinal changes are validated for their practicality and suitability to future missions and operational scenarios. The structures and capabilities of defense organizations are aligned with new or modified doctrine and Departmental procedures for support. Commands, Services, agencies, and other organizations work in concert to execute DoD warfighting, peacekeeping, humanitarian, and other missions.

**Structure Organizations & Forces** develops improved military and supporting organizations. Force structures provide the core defense capability to conduct operations. Their design evolution involves integrating changes to doctrine, weapons, people, and support, over time, to

#### **DETERMINE REQUIREMENTS**

- Evaluate Capabilities & Performance
- Develop Doctrine
- Structure Organizations & Forces
- Produce Requirements

*Continued*

achieve a "best" balance of operational performance across the full spectrum of anticipated missions. Force structure design is the basis for asset and support requirements. Conversely, the ability to provide the right assets and deliver support to forces constrains the force structure envelope. In the post-cold war environment, new approaches such as reconstitution offer opportunities to anticipate, avert, and respond to threats by ensuring a capability for building up the force, over time. Other organizational requirements enter into resource/management programs from the routine support and administration of the Department.

**Produce Requirements** develops asset requirements to support doctrine and organization/force structure. For example, it develops the operational parameters of new weapon systems. Materiel, personnel, and other asset requirements are expressed in terms of operational performance, as well as timing and cost envelopes. Specific capability requirements are defined through Required Operational Capabilities (ROCs), Operational Requirement Documents (ORDs), and other requirements documents.

### **A13 Develop Plans**

#### **DEVELOP PLANS**

- Identify Objectives/Missions
- Develop Courses of Action
- Develop Detailed Plans
- Direct Execution

This activity develops military plans and resource/management plans within the context of the Joint Strategic Planning System (JSPS) for warfighting plans, and the Planning, Programming, and Budgeting System (PPBS) for resources. All plans of the Department are produced in this activity, based on civilian and military requirements. Conversely, planning generates new requirements and impacts on policy (e.g., determines the limits of policy). The Goldwater-Nichols Reorganization Act of 1986 (Public Law 99-433) calls for reconciling strategy and military requirements with available resources, thus explicitly recognizing the need for integrating military planning with program

#### DEVELOP PLANS

- Identify Objectives/Missions
- Develop Courses of Action
- Develop Detailed Plans
- Direct Execution

*Continued*

planning in a constrained resource environment. This activity also produces the plans formulated in response to statutory and legislative requirements and the standards for evaluating plan performance (e.g., occupational safety and health, environmental protection, technology transfer, and survivor's benefits).

Military planning addresses both deliberate and crisis situations. The fundamental difference is in the sequencing, timing, and depth of detail in the planning process. Detailed plans, including Operation Plans (OPLANs), support plans and annexes, and mobilization plans are usually prepared to meet future contingencies and are "put on the shelf" until needed. Crisis planners may use "on the shelf" contingency plans by tailoring them for the immediate situation or by developing new plans.

Exercises are planned to support the Joint Strategic Capabilities Plan (JSCP) strategy and plans. Typically, an exercise is initiated through a Significant Military Exercise Brief (SMEB), approved by the Chairman, JCS, resulting in a deployment order. There are four activities in **Develop Plans**:

**Identify Objectives/Missions** reviews strategic guidance such as the JSCP and the DPG, and assessments of the situation. As a result, military commanders and Department managers identify and reconcile missions and objectives. Objectives specify targets against which progress (success or failure) of defense activities are evaluated. Tasking guidance, such as the JSCP and the Warning Order issued by the Chairman of the JCS, establishes the boundaries that constrain planning.

**Develop Courses of Action**, performed by supported and supporting commanders and their staffs, develops options and alternative Courses of Action (COAs) for accomplishing mission objectives. Department managers also develop options for acquiring assets and providing support

## DEVELOP PLANS

- Identify Objectives/Missions
- Develop Courses of Action
- Develop Detailed Plans
- Direct Execution

*Continued*

capabilities. Options are assessed for their suitability, feasibility, acceptability, consistency with Joint Doctrine, and risk. Based on the estimate of the situation, decision-makers review and approve recommended options/COAs and issue detailed planning guidance. The selected COA becomes the basis for subsequent development of a detailed, executable plan.

**Develop Detailed Plans** guides, develops, integrates and approves detailed (executable) plans that support military missions and capability requirements. Forces are assigned for use and apportioned for planning to combatant commands to support their missions in accordance with the JSCP. Organizations that are responsible for planning (e.g., Commands, Services, agencies) develop source plans with actual units and assets. Allocation is performed within approved authorizations. Often there are shortfalls in available resources that must be resolved through re-planning or re-allocations, or be programmed for new capabilities at successive levels in the planning hierarchy. These shortfalls may, in fact, place limits on forces and doctrine and can impact policy.

Availability of host-nation support established through treaties and agreements (e.g., NATO) is part of the integrated planning, requirements, and policy process for each scenario. For example, support needs may be fulfilled through programmed US capabilities, mobilization of US assets, or specific agreements with other nations.

**Direct Execution** provides Operation Orders (OPORDs) that contain the necessary information for execution. The National Command Authority authorizes the Chairman, JCS to issue an Execute Order to commanders to initiate operations. Comparative analysis is performed to determine the need for re-planning and new orders based on operational experience. Other orders terminate operations.

For acquisition, planning guidance establishes the relationships among requirements and the

following activities of PPBS and acquisition management. On the resource/management side, planning leads into the programming and budgeting stages of the PPBS, which are described below.

#### **A14 Allocate Resources**

##### **ALLOCATE RESOURCES**

- Develop Programs/Budgets
- Consolidate & Prioritize
- Balance Programs/Budgets

This activity develops resource needs into programs submitted as Program Objective Memoranda (POMs). It includes the Programming and Budgeting phases of the PPBS. The PPBS is the single mechanism to develop funding/authorization levels and force allocations of the Department relative to the capabilities and timing requirements established in the previous activities that respond to the DPG. Resource needs are consolidated to align timing, eliminate duplication, and establish integrated priorities. The Defense Planning and Resources Board (DPRB) reviews issues and determines a final position in the Budget Estimate Submission (BES) which is incorporated in the Defense Budget. The Defense Budget is submitted as part of the President's Budget to Congress for authorization and appropriation. There are three activities in **Allocate Resources**:

**Develop Programs/Budgets** develops specific programs to acquire assets, manage assets and capabilities, and conduct operations. The Military Departments and Defense agencies transmit their proposed resource needs in POMs. Commander in Chief (CINC) Integrated Priority List (IPL) requirements are addressed by the Services in the POMs.

**Consolidate & Prioritize** assesses the proposed programs for operational effectiveness, priorities, timing, and risk. The PPBS process provides for a Chairman's Program Assessment (CPA) that assesses the risks inherent in the composite force proposed in the Service and Defense Agency POMs. OSD reviews the Service's POMs and the

#### ALLOCATE RESOURCES

- Develop Programs/Budgets
- Consolidate & Prioritize
- Balance Programs/Budgets

*Continued*

CPA, and identifies alternatives for those issues in which OSD differs with the Service approach.

**Balance Programs/Budgets** addresses issues through the Defense Planning and Resources Board (DPRB), resulting in final positions announced via Program Decision Memoranda (PDM). Revised POMs are then transformed into Service Budget Estimate Submissions (BESs). A DPRB Budget Review culminates in Program Budget Decisions (PBDs) which are incorporated into the Defense Budget. The Future Years Defense Program (FYDP) records the resourced position of the Department including each Service's submissions in terms of personnel, equipment, training, and acquisition in support of the National Military Strategy. The FYDP reflects the "best" program balance between current force readiness, institutional modernization, force structure, and the ability to sustain current and programmed future forces.

It is this resourced program that is consolidated into the President's Budget and forwarded along with detailed budgets for the next years to the Congress for approval. Approval to expend monies on specific programs comes through the Defense Appropriation legislation. Quantities of personnel and materiel are also approved for specific programs through the Defense Authorization legislation.

The resourced position of the FYDP, as approved through the budget and appropriation/authorization process, is documented for execution by the Office of the Secretary of Defense, the Defense Agencies, and Military Departments by the manpower/unit authorization documents (e.g., The Army Authorization Document System (TAADS) for the Army) for battalions/separate companies, ships, and aircraft squadrons. Approved programs and budgets contain resourced operating tempos (OPTEMPOs — such as ship and submarine steaming hours, aircraft and helicopter flying hours, or tactical vehicle miles driven) for peacetime levels of unit training to achieve

acceptable levels of unit/force readiness and organizational proficiency. These are the resource positions that fund execution of the other major activities of the enterprise: **Acquire Assets, Provide Capabilities and Employ Forces.**

## A2 ACQUIRE ASSETS

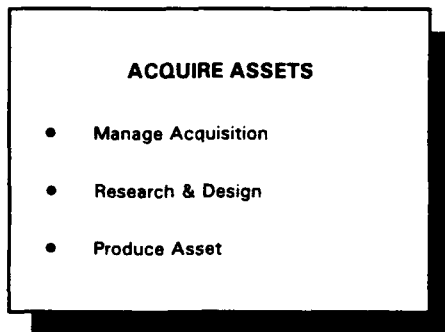

This major activity of the defense enterprise obtains assets to support requirements, bounded by the resources, timing, and force structures established in the previous major activity, **Establish Direction**. Assets are defined as those people, goods, and services for which the Department expends monies and receives civilian and military personnel, materiel items of inventory, facilities, real estate, and services or some other specified deliverable that will be managed by the Department.

Acquisition of assets includes the detailed reconciliation of requirements to include the assessment of available goods and services, acquisition of technology and developmental items, purchasing, manufacturing, testing, and any preparation necessary to ensure delivery of a useable asset through the asset distribution systems (e.g., personnel, equipment). Therefore, for example, accession training for military personnel is included in this activity. There are three activities in **Acquire Assets**:

**Manage Acquisition** defines and promulgates regulations, policies, and procedures; defines procurements; and conducts the procurements.

**Research & Design** includes the conduct of research, design, and testing to advance the state of the art and to define performance requirements and physical characteristics of assets to be produced. It also validates that the designs and resultant products comply with the requirements.

**Produce Asset** results in manufactured items unique to DoD requirements; the construction of facilities; and the accession of people for both civilian and military billets.

The acquisition process is complete when DoD receives and accepts potential assets or rejects them.

## **A21 Manage Acquisition**

### **MANAGE ACQUISITION**

- Develop Acquisition Guidance
- Define & Justify Program
- Administer Acquisition

The management of the acquisition process defines and promulgates regulations, policies, and procedures; defines procurements; and conducts the procurements. There are three activities in **Manage Acquisition**:

**Develop Acquisition Guidance** converts Defense Policy and Guidance and Budgets & Authorizations to Acquisition Guidance in the form of Defense Federal Acquisition Regulations (DFARS), Department of Defense Directive 5000.1, and other policies and procedures. It reviews procurement status and provides approval or rejections of acquisition program definitions, procurement plans, and actions brought forward for approval. It converts POM elements and budget line items into requirements. It also establishes procurement processes and procedures.

**Define & Justify Program** analyzes requirements and balances them against the known status of assets that the Enterprise already has in order to define potential mixes of assets to satisfy the requirement and select the best alternative for acquisition programs. Shortfalls are established and program direction is received that specifies the procurement approval criteria and procedures. Proposed programs are submitted for approval.

**Administer Acquisition** includes the activities of Program Managers, Procurement Contracting Officers, Administrative Contracting Officers, their staffs, and supporting technical functions in the conduct of all types of procurements such as

#### MANAGE ACQUISITION

- Develop Acquisition Guidance
- Define & Justify Program
- Administer Acquisition

*Continued*

managed acquisition programs, small purchasing, research and development, automated data processing equipment, and architecture, engineering and construction. Equivalent personnel process other types of agreements.

It should be noted that assets themselves are not touched by these activities. This is the management of a process that starts with the receipt of requirements and ends by signifying acceptance that the received people, supplies, and services conform to agreement-specified requirements.

## A22 Research & Design

#### RESEARCH & DESIGN

- Conduct Research
- Design
- Test & Evaluate

This activity conducts research, design, and testing to advance the state of the art, and to define performance requirements and physical characteristics of assets to be produced. It develops standards and specifications and validates that the designs and resultant products comply with the requirements. **Conduct Research** ranges from basic research to advance scientific knowledge to demonstration/validation efforts to prove the value of system technology. **Design** is an iterative process that includes all of conceptual through production design in both the architectural and engineering sense. **Test & Evaluate** includes test planning, the performance of testing, and the evaluation of results. There are three activities in **Research & Design**:

**Conduct Research** includes scientific study and experiments to increase knowledge of the physical, engineering, environmental, and life sciences. It progresses from basic research through exploratory and advanced research to establish the basis for full scale engineering development. Basic research addresses technology and knowledge of potential value to the national security mission as well as the US industrial base. Exploratory development assesses the feasibility and practicality of proposed solutions and standards to military problems short of producing

## RESEARCH & DESIGN

- Conduct Research
- Design
- Test & Evaluate

*Continued*

an actual asset. Advanced development produces test assets to prove-out solutions that have potential military applications. Selected programs go through a development phase to reduce the risk associated with technology innovation in a real-world environment. These include Advanced Technology Demonstrations (ATDs).

**Design** is the iterative process of developing designs that specify the form, fit, and function of assets. The possibility of non-developmental items (NDIs) is considered to reduce costs and speed development. Alternative designs are assessed to achieve the best balance of performance, supportability, costs, and risk. Total asset requirements are addressed, including equipment, materiel, facilities, people, and life-cycle support. Manufacturing requirements are considered in the design process to ensure the ability to produce assets. Resource availability (e.g., the labor pool, the part of the electromagnetic spectrum available for defense) is also a key factor in sound designs. The health of the industrial base, US competitiveness, and the ability to reconstitute are integral to the engineering process.

**Test & Evaluate** is the major control mechanism of the **Acquire Assets** activity. Acquisition programs advance from one phase to the next and qualify for major new funding increments by achieving management and oversight thresholds verified by testing and evaluation. In the case of selected program designs, test articles are evaluated. These can be refined until judged ready for production or program termination.

## PRODUCE ASSET

- Manufacture Items
- Construct Facilities
- Access Personnel
- Take Delivery

### A23 Produce Asset

This activity includes the manufacture of supplies unique to DoD requirements; the construction of facilities; and the accession of people for both civilian and military billets. The acquisition process is complete when DoD receives and signifies acceptance of or rejects potential assets.

## PRODUCE ASSET

- Manufacture Items
- Construct Facilities
- Access Personnel
- Take Delivery

*Continued*

This activity represents the actual building/manufacture, employment through recruiting (accession), and receiving of assets to include all activities typically associated with bringing new personnel, materiel items, real estate/facilities, or services into the inventory (e.g., first destination transportation of materiel items by the vendor from source of acquisition to point of DoD distribution is included). This activity also includes preparing assets for distribution to include any actions necessary to ensure minimum essential asset usefulness at the point of receipt (e.g., providing all military personnel with initial entry training to produce useful officers and enlisted personnel). There are four activities in **Produce Asset**:

**Manufacture Items** represents the detail fabrication, assembly, and inspection of weapons, parts and equipment. The process may be performed by either Government, private industry, or both. The process includes planning, providing required resources, obtaining materials by other than procurement, and production operations.

**Construct Facilities** represents the detailed fabrication, assembly, and inspection of facilities. The process may be performed by either Government, private industry, or both. The process includes planning, providing required resources, obtaining materials by other than procurement, and construction operations.

**Access Personnel** is the function that enlists the skills and services of people to satisfy the DoD mission. It includes the recruiting of military personnel and the employment of government civilian personnel. To obtain a minimally useful individual, all basic training and initial orientation are included in this function.

**Take Delivery** performs an evaluation of real estate, facilities, supplies, services, and people to assure that they comply with requirements. Facilities, supplies, and services may have been

manufactured or constructed to Government specification or they may be received directly as commercially available products and services. All people and things entering in the Enterprise must be received before they become Government assets. In addition, procured items must be accepted by procurement in response to notification that they satisfy requirements.

### A3 PROVIDE CAPABILITIES

#### PROVIDE CAPABILITIES

- Manage Assets
- Support Assets
- Provide Administrative Services
- Develop Capabilities

This major activity manages the total asset inventory of the DoD (active and inactive military personnel, goods, and services); develops the capabilities and infrastructures needed for support activities; readies force and support units; and provides routine/peacetime and mission support including the mobilization, deployment/re-deployment, and sustainment of forces. Supporting Commands, the Services, and Defense Agencies perform support functions such as supply, maintenance, and transportation, at fixed sites in CONUS and abroad, to achieve peacetime readiness, power projection, and operational objectives. There are four activities in **Provide Capabilities**:

**Manage Assets** controls the allocation of all assets within the Department to organizations, units, or specific inventories. Personnel and materiel assets are assigned to units and organizations in accordance with peacetime and mobilization authorization/distribution plans and the disposition of assets to be maintained, enhanced, transported, or separated.

**Support Assets** sustains people, goods, and services necessary to maintain, enhance, transport, and separate assets. These activities are the national- and local-level actions necessary to conduct and evaluate each of these functions in peacetime and in war.

**Provide Administrative Services** involves administrative support to people and other assets.

#### PROVIDE CAPABILITIES

- Manage Assets
- Support Assets
- Provide Administrative Services
- Develop Capabilities

*Continued*

The services care for the assets, independent of the unique nature of the defense mission. It includes such diverse services as informing and advising people; providing administrative/management support; supporting and maintaining information operations; providing financial and facility/office services; and providing community services.

**Develop Capabilities** entails the assembly, training, and evaluation of personnel and materiel assets into units and organizations that provide capabilities used to perform all enterprise activities.

### A31 Manage Assets

#### MANAGE ASSETS

- Determine Ability to Provide Capabilities
- Decide Disposition
- Assign Assets

This activity controls the allocation of all assets within the Department to organizations, units, or specific inventories. Personnel and materiel assets are assigned to units and organizations in accordance with peacetime and mobilization authorization/distribution plans and the disposition of the asset to be maintained, enhanced, transported or separated. Departmental-level asset managers will interact with subordinate elements to ensure optimum assignments within the constraints of available assets, replenishment capabilities, and authorized levels of unit/inventory fill.

The same approach is used for funds allocation throughout the Department, through the mechanisms of executing command operating budgets, funds authorization, and execution reporting. Depending on organization type, services may also be assigned. Assets may be assigned to active or reserve units or to inactive status (e.g., Individual Ready Reserve, standby, or retirees for personnel) or earmarked for transport or separation. There are three activities in **Manage Assets**:

**Determine Ability to Provide Capabilities** matches peacetime, transition, and wartime

- MANAGE ASSETS**
- Determine Ability to Provide Capabilities
  - Decide Disposition
  - Assign Assets

*Continued*

requirements for assets against the DoD inventory. The inventory is managed to make visible and accessible reserve personnel, civilian assets available under emergency and wartime conditions, and other assets available through agreements with the civilian sector and allies. Criteria, including cost, are applied to obtain the best mix and timing of assets from various sources, substitute items, reconstitute pipelines, and in general optimally satisfy needs. Unfilled requirements determine new acquisition needs.

**Decide Disposition** determines the best decisions and actions to take with respect to all assets. It determines if an asset should be maintained, upgraded, positioned, or separated, and in what sequence this should be performed.

**Assign Assets** determines the best way to assign assets to organizations for their use; to assign assets to organizations for their maintenance, upgrade, positioning, and separation; and to collect information relevant to the performance of assets, including contracted-for services.

### **A32 Support Assets**

- SUPPORT ASSETS**
- Maintain
  - Enhance
  - Transport
  - Separate

This activity sustains people, goods, and services necessary to maintain, enhance, transport, and separate assets. These activities involve the national- and local-level actions necessary to conduct and evaluate each of these functions in peacetime and in war. There are four activities in **Support Assets**:

**Maintain** includes the maintenance and repair of materiel items and systems (to include automation systems) through depot-level maintenance; the healing of sick/wounded personnel and caring for their dependents through dispensaries and medical clinics/hospitals; and the maintenance and repair of facilities and real estate.

**Enhance** includes the post-accession individual training for skill progression and career

#### SUPPORT ASSETS

- Maintain
- Enhance
- Transport
- Separate

*Continued*

advancement at the Service branch schools and colleges/universities. It includes the planned and programmed refurbishment and modification of materiel items that result in enhanced capabilities and changes to facilities that also improve their utility. As a result of this activity, personnel gain skill qualifiers and existing materiel items change functions/capabilities.

**Transport** includes all actions necessary to deploy assets and units from one place to another. Movement of forces and assets in the AOR is addressed in **Employ Forces**. Typically, the movement of assets involves inter-theater transportation/lift (ground, sea, or air). **Transport** also entails all actions necessary to recover and account for all forces and assets once an operation/exercise has been concluded, to include the re-deployment or retrograde of materiel and personnel from missions and areas of operation. This activity also involves the recurring peacetime movement of individual assets for unit replacement, sustainment, or separation, including moving service members, their families, and household goods.

**Separate** includes all actions called for by Department or other government regulations to support separation of assets from US government control and accountability. This includes routine peacetime or demobilization actions related to active and inactive inventories of personnel, materiel, facilities, and real estate (e.g., foreign military sales, demilitarization of munitions, environmental clean-up, and one-time benefit assignments associated with death and disability).

#### PROVIDE ADMINISTRATIVE SERVICES

- Inform & Advise
- Provide Information Operational Services
- Provide Financial Services
- Provide Facility Services
- Provide Community Services

### **A33 Provide Administrative Services**

This activity provides administrative support to people and other assets. The focus of the services is to care for the assets, independent of the particular nature of the defense activities in which they are involved. It includes such diverse activities as informing and advising people (both

**PROVIDE ADMINISTRATIVE SERVICES**

- Inform & Advise
- Provide Information Operational Services
- Provide Financial Services
- Provide Facility Services
- Provide Community Services

*Continued*

internal and external DoD); providing administrative/management support; supporting and maintaining information operations; providing financial and facility/office services; and providing community services. There are five activities in **Provide Administrative Services**:

**Inform & Advise** provides explanations and expert opinions to people on such matters as health benefits, legal rights, personnel policy, and job openings. The focus of the activity is on the personal concerns of people, as opposed to their needs associated with their defense responsibilities.

**Provide Information Operational Services** carries out the day-to-day generic operations required to deliver information-processing support to users. Such services include installing computers and related equipment, setting up LANs, replacing equipment with newer versions, loading application software packages, and packing equipment for shipment.

**Provide Financial Services** examines financial records (such as time reports, travel expense reports, and financially significant events occurring throughout the Defense enterprise); identifies discrepancies, errors, and misrepresentations; associates findings with corresponding records; and creates financial transactions appropriate to the functions of the records (such as paychecks and travel expense reimbursements, corrections to previous tax withholdings, W-2 statements).

**Provide Facility Services** ensures that workplaces continue to operate in an orderly manner through activities such as processing mail, replenishing supplies of consumable assets, holding social functions, providing clerical services, and provide physical security.

**Provide Community Services** ensures that qualified military and civilian personnel and families have access to such services and facilities

as commissaries, post or base exchanges, schools for military dependents, housing, social and athletic activities, and religious institutions.

### **A34 Develop Capabilities**

#### **DEVELOP CAPABILITIES**

- Integrate
- Train Units & Organizations
- Assess Readiness

This activity entails the assembly, training, and evaluation of personnel and materiel assets into units and organizations that provide capabilities used to deter and wage war, provide support, and administer the Department. There are three activities in **Develop Capabilities**:

**Integrate** forms organizational elements from individual military and civilian personnel and materiel items that have been assigned or distributed to units. It integrates personnel and equipment within the command structure of a unit or organization and imbuing those individuals with the spirit and cohesion necessary to perform a specified organizational mission.

**Train Units & Organizations** involves conducting the annual training program to maintain unit and organizational proficiency. The training program is focused on those tasks, conditions, and standards used to define and evaluate organizational/unit skills essential to performing assigned missions or functions.

**Assess Readiness** performs the evaluation of unit/organizational asset status and proficiency to accomplish assigned missions. It usually includes an objective measurement of asset status, a subjective assessment by commanders of the unit's ability to perform the mission, and the reporting, tracking, and monitoring of that status through the Joint Reporting Structure (JRS) and the Service support systems.

#### EMPLOY FORCES

- Constitute Forces
- Provide Operational Intelligence
- Conduct Operations
- Sustain Operations

## A4 EMPLOY FORCES

This major activity of the enterprise encompasses all the actions associated with executing National Command Authority (NCA) decisions and orders within the context of the National Military Strategy. Main elements of the strategy include: forward military presence, crisis response, and strategic deterrence and defense.

All plans and orders are developed and issued in the first activity of the enterprise, **Establish Direction**. **Employ Forces** operations are conducted to execute the assigned missions of the Department when called upon by the President in times of peace, crisis, warfighting, war termination, and reconstitution after an operation. Exercises are usually undertaken at the direction of an authority below the NCA. There are four activities in **Employ Forces**:

**Constitute Forces** develops and prepares the command structures and the forces in the Area of Responsibility (AOR) that will respond to the NCA direction to conduct an operation or to perform a joint exercise.

**Provide Operational Intelligence** identifies specific requirements for managing operational intelligence; assesses the operating environment; collects raw intelligence from a variety of sources; fuses and analyzes the data; and distributes finished intelligence products to Commanders, when, where, and in the form needed to support operations in the field.

**Conduct Operations** conducts major training exercises and operational missions. Exercises take place in a service joint/combined employment force structure environment. This activity involves the control and evaluation of force readiness or organizational proficiency through tests and exercises to include field/fleet, command post, and deployment exercises. It includes

#### EMPLOY FORCES

- Constitute Forces
- Provide Operational Intelligence
- Conduct Operations
- Sustain Operations

*Continued*

Conventional, Nuclear, Space, Special and Inter/Intra Government Operations.

**Sustain Operations** sustains forces in the AOR. It maintains materiel, sustains people, provides supplies, and moves assets throughout the AOR before operations commence, during execution, and after operations terminate. The activities are integrated into the combatant Commander's scheme of maneuver, fires, protection, and strike, so they provide the right support at the right time and place to achieve mission objectives. This activity is related to **Support Assets** in A3. While similar, these two activities are usually performed in different environments, and under different command/management. Therefore, they are perceived to be distinct and different activities within the DoD community. DoD's objective is to integrate these activities seamlessly.

#### A41 Constitute Forces

#### CONSTITUTE FORCES

- Organize Command
- Assess Plans & Orders
- Integrate Forces

This activity develops and prepares the command structure and the forces in the Area of Responsibility (AOR) that will respond to the National Command Authority (NCA) direction to conduct an operation to perform a joint exercise. There are three activities in **Constitute Forces**:

**Organize Command** organizes a command or task force and assigns units based on assigned tasks. In some cases, units are already assigned, and this activity changes command assignment of organizations allocated to the operational command structure of a supported Commander in Chief (CINC), Joint Task Force commander, or other combatant commander within an assigned AOR.

**Assess Plans & Orders** assesses plans, orders, Rules of Engagement (ROE) and the status of plan execution. Of particular importance for the Commander is the arrival and integration of assigned units into forces in the AOR as prescribed by the plan and as they are being

deployed through the **Transport** activity described earlier.

**Integrate Forces** integrates units from multiple services into a joint force, and integrates units from multiple countries into a combined force. The combined force may include US, allied and coalition forces.

## A42 Provide Operational Intelligence

### PROVIDE OPERATIONAL INTELLIGENCE

- Collect Operational Intelligence
- Fuse/Analyze
- Provide Products to Commanders

This activity identifies specific requirements for managing operational intelligence; assesses the operating environment; collects raw intelligence from a variety of sources; fuses and analyzes the data; and distributes finished intelligence products to Commanders, when, where, and in the form needed to support operations in the field. There are three activities in **Provide Operational Intelligence**:

**Collect Operational Intelligence** responds to specific requirements for intelligence information which are identified prior to and during operations. These include the enemy order-of-battle, intentions, facilities and installations, civilian populations, operational environments, weather, status of friendly forces, logistics, command and control, and damage assessments. Intelligence capabilities at the national and theater levels are focused on the specific needs of the theater commanders. Various collection assets are employed at the national and theater levels to gather human, communications, signal, and imagery data (raw intelligence).

**Fuse/Analyze** fuses and analyzes intelligence data to produce finished intelligence products useful to Commanders. Different sources such as *national intelligence* are compared to evaluate estimates of the emerging situation until a level of certainty is reached.

**Provide Products to Commanders** provides finished intelligence products, including assessments and data necessary for conducting operations (e.g., targeting information) to Commanders in a timely and secure manner. Different media are used to present the information to maximize its utility.

### **A43 Conduct Operations**

#### **CONDUCT OPERATIONS**

- Conduct Conventional Operations
- Conduct Nuclear Operations
- Conduct Space Operations
- Conduct Special Operations
- Conduct Inter/Intra Government Operations

This activity conducts major training exercises and operational missions. Exercises take place in a service/joint/combined employment force structure environment. This activity evaluates force readiness or organizational proficiency through tests and exercises to include field/fleet, command post, and deployment exercises.

Operational missions are initiated by the NCA and involve executing the approved concept of operation and scheme of maneuver and fires (if applicable) embedded in the OPLAN, to include all the nested concepts developed and executed by subordinate commanders to achieve the mission objectives of the plan. There are attendant departmental/agency consequences in terms of increased workloads and other mobilization effects that are also captured in this activity.

Activities in this area are sometimes initiated at the direction of the President in concert with the Domestic Policy Council, and sometimes with the Governors of the States and Territories. This activity can involve the use of federal and National Guard forces to provide assistance at times of national disaster, to support federal, state and local infrastructure initiatives, and to restore civil order. There are five activities in **Conduct Operations**:

**Conduct Conventional Operations** includes operations conducted by general purpose forces which do not include the use of nuclear weapons. These operations include peacekeeping, and major and lesser regional conflicts. Conventional

### CONDUCT OPERATIONS

- Conduct Conventional Operations
- Conduct Nuclear Operations
- Conduct Space Operations
- Conduct Special Operations
- Conduct Inter/Intra Government Operations

*Continued*

operations are performed by air, land, and maritime forces to gain, maintain, and exploit control of the operational environment in forward and rear areas of operations. They include joint air defense/air space management operations, and integrated fire support operations.

**Conduct Nuclear Operations** uses Nonstrategic Nuclear Forces (NSNF) and Strategic Nuclear Forces (SNF) to deter conflict by posturing forces to conduct nuclear operations in response to a threat of an attack against vital US interests and to employ the NSNF and NSF as directed by the NCA. NSNF provide an escalatory or retaliatory response below the level of strategic nuclear forces and serve as a deterrent to weapons of mass destruction. Strategic nuclear operations protect against strategic nuclear attack on the US, and plans, safeguards, executes, recovers/reconstitutes, and terminate nuclear offensive operations.

**Conduct Space Operations** includes operations that provide freedom of action in space for friendly forces while, when directed, denying it to any enemy, and encompasses the broad aspects of protection of US and allied space systems and negotiations of enemy space systems.

**Conduct Special Operations** includes operations conducted by specially trained, equipped, and organized DoD forces against strategic or tactical targets in pursuit of national military, political, economic, or psychological objectives. These operations may be conducted during periods of peace or hostilities. They may support conventional operations, or they may be prosecuted independently when the use of conventional forces is either inappropriate or infeasible.

**Conduct Inter/Intra Government Operations** includes operations conducted in coordination with other nations and US government agencies, states and localities, for humanitarian assistance, disaster relief, support to civil authorities and

other operations which are not a response to a direct military threat.

#### A44 Sustain Operations

##### SUSTAIN OPERATIONS

- Maintain Materiel
- Sustain People
- Resupply
- Move

This activity sustains forces in the AOR. It maintains materiel, sustains people, provides supplies, and moves assets throughout the AOR before operations commence, during execution, and after operations terminate (e.g., for re-deployment out of the AOR). The activities are integrated into the combatant Commander's scheme of maneuver, fires, protection, and strike, so they provide the right support to the forces at the right time and place to achieve mission objectives. The functions described in **Sustain Operations** are similar to sustaining base functions described in **Provide Capabilities**. However, those sustaining operations are generally conducted in the Continental US (CONUS) as part of the routine operation of the department and preparation to meet contingencies (e.g., mobilization). The activities described here occur on the "battlefield," in extreme environments and under hazardous conditions. They often involve different mechanisms (e.g., systems) and controls, and are usually performed as an integral part of a military operation (see **Conduct Operations**). There are four activities in **Sustain Operations**:

**Maintain Materiel** keeps equipment, weapons, facilities, and other materiel assets in repair in the AOR so they can be employed in operations.

**Sustain People** houses, feeds, clothes, provides medical care for, and provides other support needed by military personnel and civilians in the AOR.

Sustainment activities such as military and civilian pay remain in A3 because the process is always the same.

**Resupply** provides items for consumption and replacement, such as food, fuel, ammunition, and spares.

**SUSTAIN OPERATIONS**

- Maintain Material
- Sustain People
- Resupply
- Move

**Move** re-positions assets from one geographical location to another within the AOR, in accordance with specified timing and other movement requirements.

*Continued*

## 6. THE DoD STRATEGIC DATA MODEL

The DoD Strategic Data Model is another critical element in the overall CIM initiative. It is the principal means by which the senior leadership of the Department has represented data-related priorities for guiding the cross-functional integration of process improvement and data standardization opportunities. The following sections provide information on the DoD Strategic Data Model and its use in developing functional area and/or component data models.

### 6.1 STRATEGIC DATA MODEL

As part of the development of the DoD Enterprise Model, the DoD Strategic Data Model has been developed to provide a framework to help the DoD functional areas improve functional processes, data, and information systems. Focused on these goals, the DoD Strategic Data Model offers a corresponding viewpoint and purpose to the activity portion of the DoD Enterprise Model.

*Viewpoint:* Secretary of Defense and civilian and military leaders authorized to carry out missions in support of the National Security and Military Strategies.

*Purpose:* To develop the standard frame of reference for identifying improvement opportunities for data and information needed to support DoD activities.

The DoD Strategic Data Model was developed in conjunction with the description of the activities in the DoD Enterprise Model. As mentioned earlier, the *National Security Strategy of the United States* and *National Military Strategy of the United States* set the context for the Enterprise Model. In addition to these sources of information, the DoD Strategic Data Model has been updated to reflect comments received from the DoD community on data needs that are of strategic importance to the operation of the Department.

Generally, the Strategic Data Model provides direction for DoD functional area data modeling efforts. These efforts are to refine and implement thirteen strategic information requirements that have been chosen by senior DoD officials as being critical to the success of the Department.

### 6.1.1 Strategic Information Needs

Data and information must become more accessible, available, relevant, timely, secure, and affordable. Data is the "glue" that makes functional integration and interoperability possible so that all the activities of DoD can work together better to meet common leadership goals, objectives, and measures of performance. Figure 6-1 is a representation of the strategic information that is critical in managing and operating the Department. The analogy used is the "data bucket" which collects and stores data about those things that are of interest to senior management. Importantly, while the thirteen buckets identify management priorities, the DoD data requirement extends beyond the management view illustrated in Figure 6-1. For example, data needs may include information about documents, geographic features, blood products, and fuel.

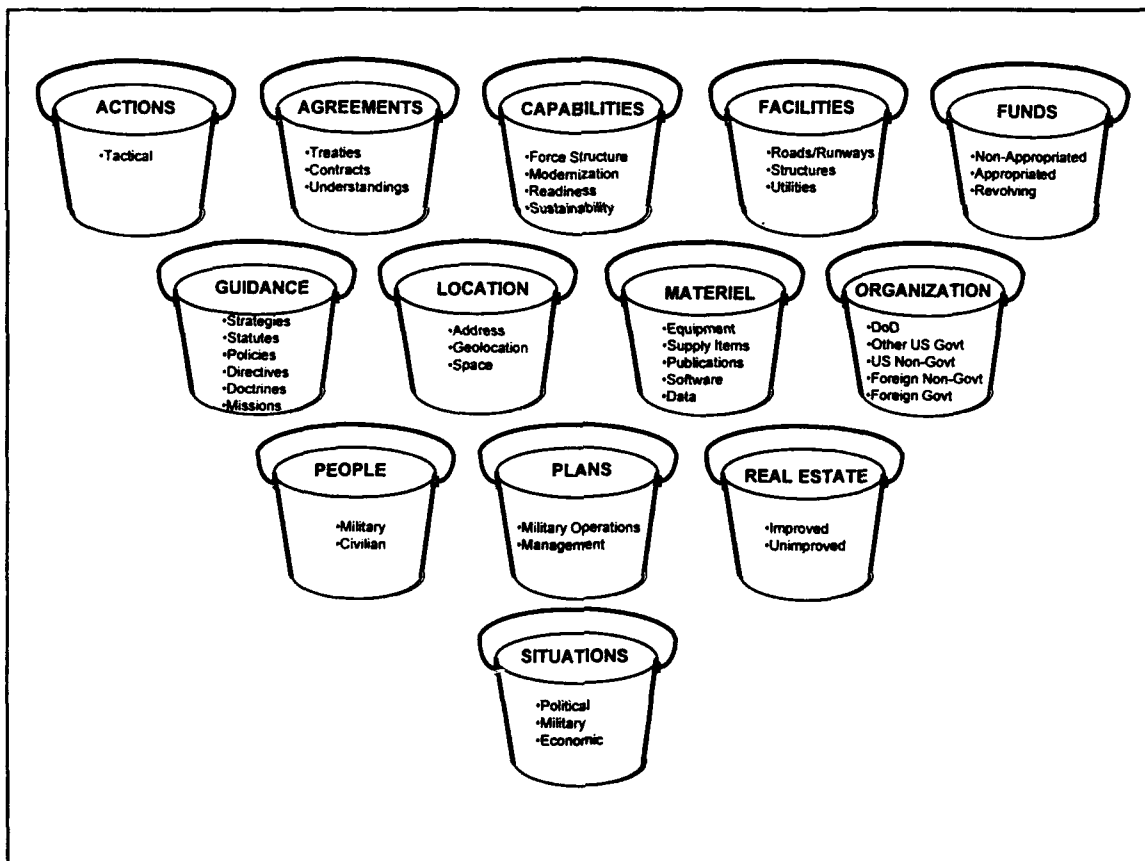

Figure 6-1. STRATEGIC LEVEL DATA BUCKETS

## 6.1.2 Relationships Between the Buckets

As the strategic view of the information which is created, managed, and used by the Department, the data buckets begin to illustrate the complexity of the data resource that is managed throughout DoD. Figure 6-2 provides an executive summary or overview of some of the strategic relationships between the data buckets that are important to the management of the Department's operations. The reader should note that the relationships between the data buckets are illustrated as lines with dots between the major areas of interest to senior DoD managers. While Figure 6-2 uses IDEF1X notation, it is only semantically correct at a very general level. A complete description of the DoD Strategic Data Model is found in Appendix C.<sup>2/</sup> A brief discussion of each data bucket is provided below to show the additional complexity of data relationships. Table 6-1 provides definitions of the 13 strategic level entities. Each definition has been approved by the appropriate functional data administrator.

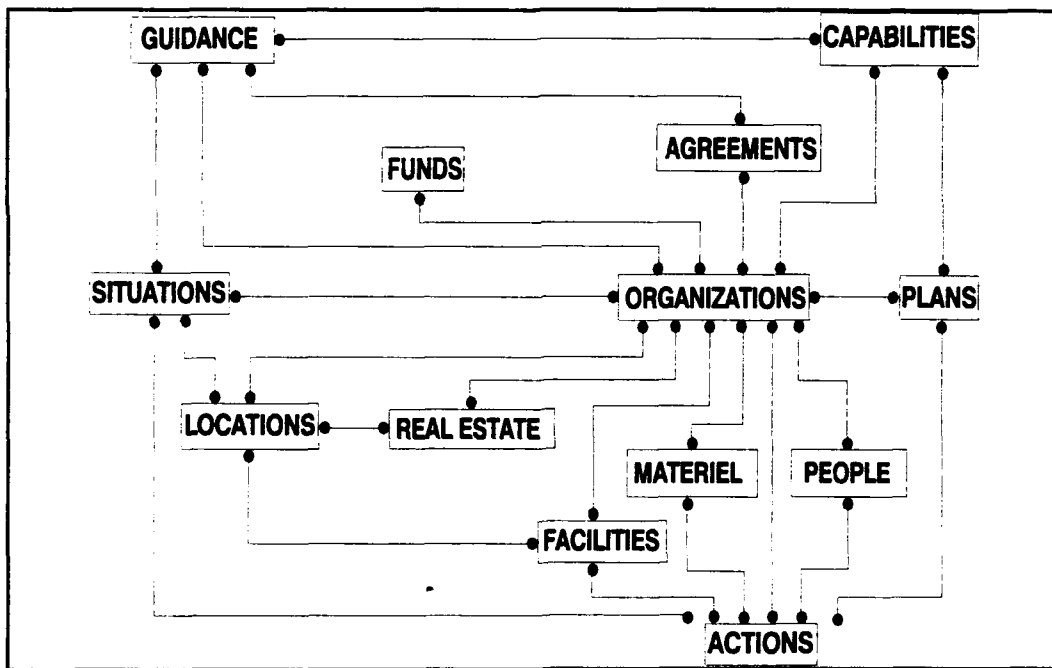

Figure 6-2. ILLUSTRATION OF RELATIONSHIPS SUPPORTED  
IN DoD STRATEGIC DATA MODEL

<sup>2/</sup> It should also be noted that while entity labeling rules are not strictly enforced in Figure 6-2, entity names in Appendix C are consistent with DoD 8320.1 series conventions. For example, the PEOPLE becomes PERSON; FACILITIES is FACILITY.

<b>ACTION</b>	An activity.
<b>AGREEMENT</b>	An arrangement between parties.
<b>CAPABILITY</b>	An ability to achieve an objective.
<b>FACILITY</b>	Physical property, having a specified use, consisting of one or more of the following: a building, a structure, a utility system, and pavement.
<b>FUND</b>	A financial resource established for a purpose.
<b>GUIDANCE</b>	A statement of direction.
<b>LOCATION</b>	A specific place.
<b>MATERIEL</b>	An object of interest that is non-human, mobile, and physical.
<b>ORGANIZATION</b>	An administrative structure with a mission.
<b>PERSON</b>	A human being.
<b>PLAN</b>	A scheme for achieving an end over time.
<b>REAL ESTATE</b>	Land, improved or unimproved, along with natural resources.
<b>SITUATION</b>	A circumstance of governmental interest.

**Table 6-1. APPROVED STRATEGIC LEVEL ENTITY DEFINITIONS**

**Strategic Information Requirements (Entities)**

■ **ACTIONS**

DoD ORGANIZATIONs carry out operations and perform appropriate ACTIONs at numerous LOCATIONs around the world. Most ACTIONs are directed by PLANs that are generated in response to a given SITUATION. ORGANIZATIONs make use of assets such as PEOPLE, MATERIEL, FUNDS, FACILITIES, and REAL ESTATE in performing these ACTIONs.

■ **AGREEMENTS**

The cooperative infrastructure necessary to mobilize US resources, and those of alliance or coalition partners is embodied in AGREEMENTs. Treaties are the most formal examples of AGREEMENTs for this purpose. In some cases, new or revised GUIDANCE may require new AGREEMENTs to be formed; while in other cases, GUIDANCE must be formulated in compliance with existing AGREEMENTs. Contracts and understandings are also examples of administrative AGREEMENTs that

apply to industry as well as DoD. Recently, United Nations Resolutions have been used to provide direction and form coalitions.

■ **CAPABILITIES**

Based on GUIDANCE derived from assessments of the world SITUATION, the required CAPABILITIES are brought into being through the development and execution of related PLANS. CAPABILITIES might be ultimately realized in ORGANIZATIONs through the compilation and application of resources. The status and LOCATION of ORGANIZATIONs and resources are monitored and their CAPABILITIES assessed continually to provide a reliable, timely understanding of US defense CAPABILITIES.

■ **FACILITIES**

Support systems, equipment, and FACILITIES provide the mechanisms for providing and sustaining required CAPABILITIES for DoD ORGANIZATIONs to perform necessary ACTIONs. FACILITIES are put in place at appropriate LOCATIONs around the world to respond to certain SITUATIONs.

■ **FUNDS**

Congress appropriates FUNDS for DoD, authorizes their expenditure, and provides GUIDANCE for their use. DoD plans, programs, and budgets for FUNDS, and allocates them to the various ORGANIZATIONs throughout the Department to carry out the requisite ACTIONs necessary to accomplish their assigned missions.

■ **GUIDANCE**

Necessary strategies, statutes, policies, regulations, doctrines, and missions are developed as GUIDANCE to appropriately meet the world SITUATION. To the extent possible, GUIDANCE is developed in advance of events which could trigger a defense response (warfighting, peacekeeping, humanitarian). AGREEMENTs that are in place constrain GUIDANCE. GUIDANCE evolves from strategies into required CAPABILITIES that in turn direct the development of specific PLANS. The GUIDANCE used to describe required CAPABILITIES will also be provided to govern ORGANIZATIONs tasked to provide the level and timing of responses to SITUATIONs.

■ **LOCATION**

LOCATION is critical to ORGANIZATIONs and to positioning their assets for employment in response to a given SITUATION. Management

of DoD assets such as PEOPLE, FUNDS, MATERIEL, and FACILITIES requires precise knowledge of their LOCATION.

- **MATERIEL**

All the equipment and supplies necessary to carry out the mission of DoD constitute the area of MATERIEL. MATERIEL is allocated to ORGANIZATIONs to establish given CAPABILITIES and enable them to accomplish assigned ACTIONs. Commanders and supporting logisticians work to ensure that the proper MATERIEL is in the proper LOCATION to respond to the current SITUATION.

- **ORGANIZATIONS**

ORGANIZATIONs acquire, manage, and use assets (PEOPLE, MATERIEL, FACILITIES, REAL ESTATE, FUNDS.) ORGANIZATIONs also prepare and position assets in the proper LOCATION to be ready to respond to GUIDANCE driven by the world SITUATION. Specific GUIDANCE, such as an operation order, directs the ACTIONs of ORGANIZATIONs to provide the appropriate level and timing of response to influence and stabilize the given SITUATION. In anticipation of such tasking, ORGANIZATIONs continually monitor, assess, and report their CAPABILITIES.

- **PEOPLE**

From the Executive and Congressional authorities who establish GUIDANCE for the Nation, to the senior Defense leaders who interpret this direction into policy for the DoD, to the military and civilian members who form ORGANIZATIONs, PEOPLE are critical to providing for the common defense. PEOPLE, who carry out the ACTIONs necessary to defend the Nation, are the single most important asset of the DoD.

- **PLANS**

PLANs are developed to achieve required CAPABILITIES based on general and specific GUIDANCE. The President's National Security Strategy of the United States and the Chairman of the Joint Chiefs of Staff's National Military Strategy of the United States provide the highest framework for the development of civilian and military PLANs. The Defense Planning Guidance provides resource constraints and leads to the Joint Strategic Capabilities Plan, which apportions projected CAPABILITIES for use in developing military operation PLANs. Operational scenarios anticipating the changing and volatile world SITUATION are developed with appropriate PLANned levels of response. ORGANIZATIONs are created and directed by these PLANs to provide the appropriate response including warfighting and support ACTIONs.

- **REAL ESTATE**

The DoD owns a vast amount of REAL ESTATE, both improved and unimproved, to support the business and warfighting missions of its ORGANIZATIONs. Some DoD REAL ESTATE, such as weapons training areas, bombing ranges, etc., cover large expanses; others might be quite small, such as a remote radar site. REAL ESTATE in the form of military bases and installations host the FACILITIES and provide the LOCATION for military ORGANIZATIONs to operate from in performing assigned ACTIONs.

- **SITUATIONS**

Political, military, economic, and natural events or conditions throughout the world, individually or collectively, comprise SITUATIONs which may require an appropriate level and timing of response to provide for the common defense. In order to provide the appropriate response and accomplish the required ACTIONs, certain SITUATIONs call for GUIDANCE to be issued.

## **6.2 USING THE DoD STRATEGIC DATA MODEL**

As illustrated by Figure 6-2 and the discussion on relationships between data buckets, the description of data needs can get very complex. An approach to managing the complexity is illustrated in Figure 6-3 which shows an example of the alignment/mapping of an activity view (*Access* — which involves the recruiting and qualifying of people) of the Enterprise Model with the corresponding data view. This side-by-side analysis shows the general approach that is used to harmonize activity and data requirements. In addition, Figure 6-3 illustrates how the DoD Strategic Data Model is used to develop data views that detail functional area data needs.

Generally, it should be noted that Figure 6-3 includes entities that are shown in the DoD Strategic Data Model (e.g., PERSON, ORGANIZATION) and entities that are not shown in the Strategic Data Model (e.g., POSITION, SKILL). Importantly, the additional data need becomes visible in connection with detailing functional area requirements. These requirements become extensions to the DoD Data Model as they are integrated with the DoD Strategic Data Model.

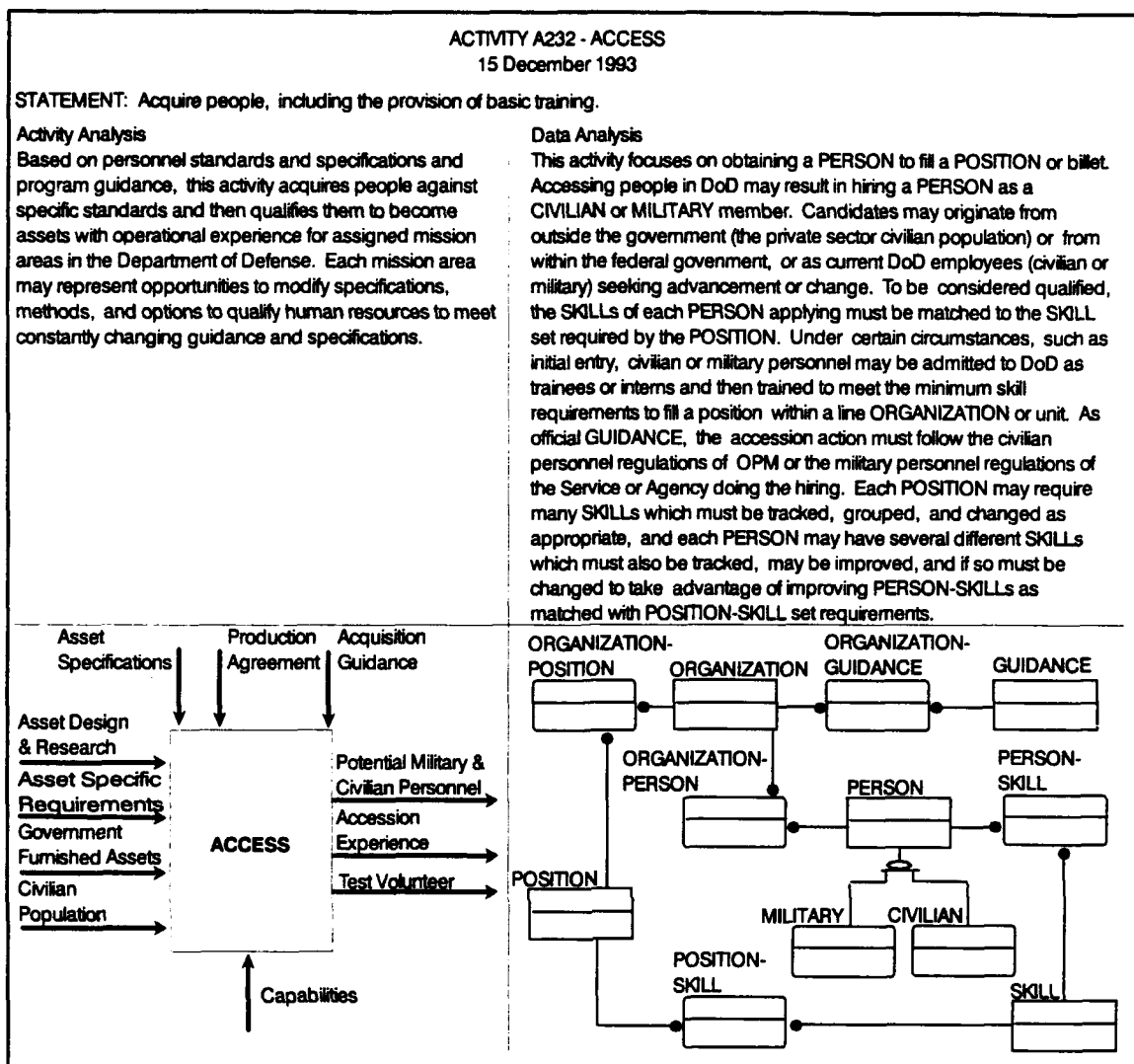

**Figure 6-3. EXAMPLE OF USING THE STRATEGIC DATA MODEL AND ACTIVITY MODEL TO DEVELOP FUNCTIONAL AREA DATA MODEL**

Basically, readers should note that the DoD Strategic Data Model is part of the DoD Data Model and provides the mechanism that facilitates the integration of functional area and Component data models (i.e., the DoD Data Model is the integrated collection of all functional area and Component data models). In addition, DoD Directive 8320.1 series guidance provides procedures that support the development and use of the DoD Data Model as the starting point for the cross-functional integration of data models and is used as the basis for data element standardization. Every DoD functional activity should be able to identify its data requirements as a partial view of the DoD Data Model. Additional information on the use of the DoD

Strategic Data Model as a mechanism for the integration of functional area data models is included in Appendix C.<sup>3/</sup>

### 6.3 GLOSSARY OF COMMON TERMS

- **Data**

A representation of facts, concepts, or instructions in a formalized manner suitable for communication, interpretation, or processing by humans or by automatic means. (FIPS Pub 11-3)

- **Data Administration (DAdm)**

That function of the organization which oversees the management of data across all functions of the organization, and is responsible for central information planning and control. (NBS Spec Pub 500-149)

- **Enterprise**

A defined functional and administrative entity that exists to perform a specific, integrated set of missions and achieve associated goals and objectives, encompassing all of the primary functions necessary to perform those missions.

- **Enterprise Model**

An information management model(s) that presents an integrated top-level representation of DoD processes and information flows.

- **Entity**

An object of interest to the enterprise. (NBS Spec Pub 500-149)

- **Functional Area**

A functional area encompasses the scope (the boundaries) of a set of related functions and data for which an OSD Principal Staff Assistant or the Chairman of the Joint Chiefs of Staff has DoD-wide responsibility, authority, and accountability. (Draft DoDI 8020.1). A functional area is comprised of one or more functional activities, each of which consists of one or more functional processes. (DoDD 8000.1)

---

<sup>3/</sup> Four data views are presented in Appendix C to illustrate the use of the Strategic Data Model. These views include: CAPABILITY, DOCUMENT, LOCATION, and FEATURE.

- **Metadata**

Information describing the characteristics of data; data or information about data; descriptive information about an organization's data, data activities, systems, and holdings. (NBS Spec Pub 500-1522)

- **Modeling**

Application of a standard, rigorous, structured methodology to create and validate a physical, mathematical, or otherwise logical representation of a system, entity, phenomenon, or process. Process improvement modeling defines and documents the current ("as is") and desired future ("to be") processes and information requirements of a functional activity. Two types of process improvement models are: (Draft DoDI 8020.1)

- **Activity Models**

Models of the activities which are (or will be) conducted within a functional activity showing inputs, outputs, controls, and mechanisms.

- **Data Models**

Models of the entity definitions, attributes, relationships, and the integrity constraints through which the information created and used by the functional activity is managed, and from which standard data are created.

**APPENDIX A**  
**THE ACTIVITY MODEL**

## THE ACTIVITY MODEL

The Enterprise Model was developed using the IDEF (Integrated Computer-Aided Manufacturing DEFinition) modeling approach. IDEF0 is used to depict activities while IDEF1X is used to depict the data that support those activities. This appendix shows the DoD Enterprise Activity models; the related data models are shown in Appendix C.

Figure A-1 on the following page shows the basic elements of an IDEF activity model. The activity itself is "what" is done. Its interfaces are depicted as arrows entering or leaving the activity box. As in other modeling methods, inputs enter from the left and outputs leave from the right of the box; the activity transforms inputs into outputs. Arrows entering at the top are controls; they provide direction and constraints. Typical controls in the DoD are policy and guidance. Arrows entering from the bottom are mechanisms. Mechanisms represent the means used to perform the activity. For example, an information system is a mechanism. The DoD Enterprise Activity Model arrow (or input, output, control, mechanism (ICOM)) definitions are contained in Appendix B.

From the basic construct of Figure A-1, an activity model of an enterprise is developed through a top-down process of decomposition. The fundamental mission of the enterprise is established as the first activity. This activity is decomposed into subordinate activities, whose interfaces must be consistent with those in the parent activity. Successive levels in the model are developed in the same way, until it is judged to be sufficiently detailed to allow for identification and analysis of potential areas for improvement.

An activity model is developed within a context and from a particular point of view. These help to establish the boundaries for analysis. The context can be a larger enterprise. For example, the defense mission is part of the larger Federal government mission. The point of view may be that of an organization or leader; the DoD Enterprise Model is an "as-is" or baseline model developed from the viewpoint of the Secretary of Defense within the context of the defense mission.

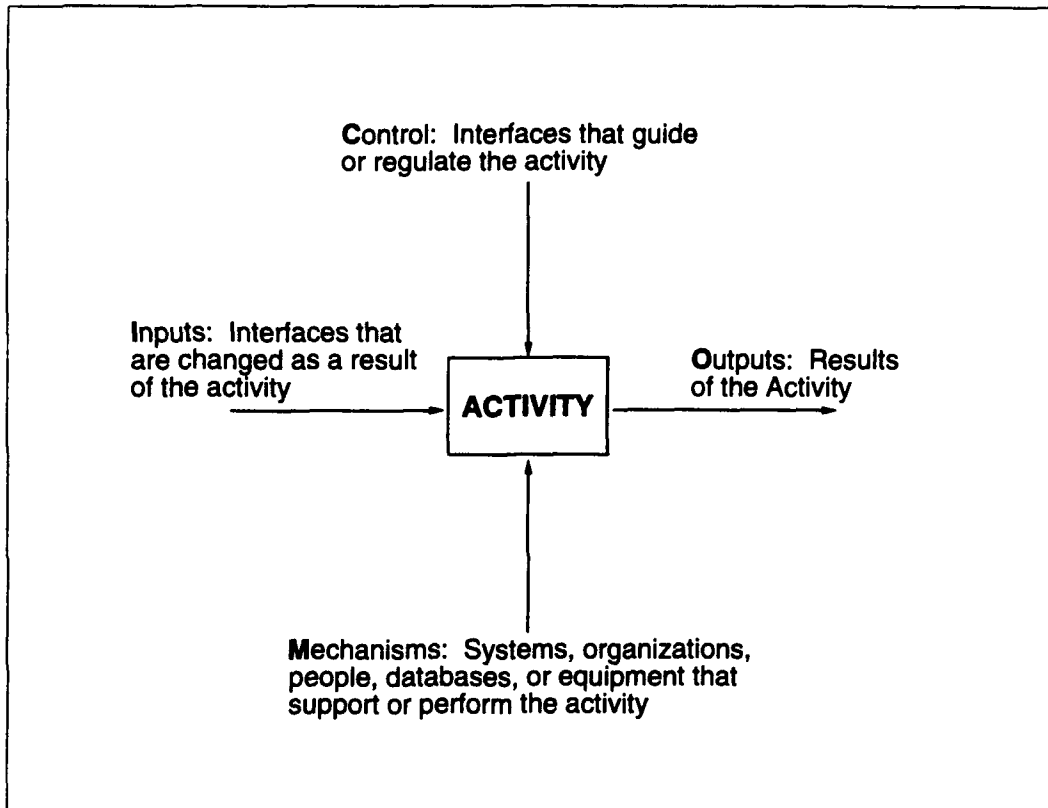

Figure A-1. AN IDEF ACTIVITY MODEL

*THIS PAGE INTENTIONALLY  
LEFT BLANK*

A0

PROVIDE FOR THE COMMON DEFENSE

A1 ESTABLISH DIRECTION

- A11 ESTABLISH POLICY
  - A111 Assess World Situation
  - A112 Establish National Security Priorities
  - A113 Establish Defense Priorities & Strategies

A12 DETERMINE REQUIREMENTS

- A121 Evaluate Capabilities & Performance
- A122 Develop Doctrine
- A123 Structure Organizations & Forces
- A124 Produce Requirements

A13 DEVELOP PLANS

- A131 Identify Objectives/Missions
- A132 Develop Courses of Action
- A133 Develop Detailed Plans
- A134 Direct Execution

A14 ALLOCATE RESOURCES

- A141 Develop Programs/Budgets
- A142 Consolidate & Prioritize
- A143 Balance Programs/Budgets

A2 ACQUIRE ASSETS

- A21 MANAGE ACQUISITION
  - A211 Develop Acquisition Guidance
  - A212 Define & Justify Program
  - A213 Administer Acquisition

A22 RESEARCH & DESIGN

- A221 Conduct Research
- A222 Design
- A223 Test & Evaluate

A23 PRODUCE ASSET

- A231 Manufacture Items
- A232 Construct Facilities
- A233 Access Personnel
- A234 Take Delivery

A3 PROVIDE CAPABILITIES

A31 MANAGE ASSETS

- A311 Determine Ability to Provide Capabilities
- A312 Decide Disposition
- A313 Assign Assets

A32 SUPPORT ASSETS

- A321 Maintain
- A322 Enhance
- A323 Transport
- A324 Separate

A33 PROVIDE ADMINISTRATIVE SERVICES

- A331 Inform & Advise
- A332 Provide Information Operational Services
- A333 Provide Financial Services
- A334 Provide Facility Services
- A335 Provide Community Services

A34 DEVELOP CAPABILITIES

- A341 Integrate
- A342 Train Units & Organizations
- A343 Assess Readiness

A4 EMPLOY FORCES

A41 CONSTITUTE FORCES

- A411 Organize Command
- A412 Assess Plans & Orders
- A413 Integrate Forces

A42 PROVIDE OPERATIONAL INTELLIGENCE

- A421 Collect Operational Intelligence
- A422 Fuse/Analyze
- A423 Provide Products to Commanders

A43 CONDUCT OPERATIONS

- A431 Conduct Conventional Operations
- A432 Conduct Nuclear Operations
- A433 Conduct Space Operations
- A434 Conduct Special Operations
- A435 Conduct Inter/Intra Government Operations

A44 SUSTAIN OPERATIONS

- A441 Maintain Materiel
- A442 Sustain People
- A443 Resupply
- A444 Move

## **A-O PROVIDE FOR THE COMMON DEFENSE**

The PROVIDE FOR THE COMMON DEFENSE "As-Is" Enterprise model presents a concise view of the activities and processes that are currently being performed to support the Department of Defense (DoD) in the satisfaction of its mission to safeguard the national interests and objectives of the US.

This model is intended to provide the framework for identifying, analyzing, and implementing simplified, streamlined, and re-engineered process changes to globally and interdependently optimize the way the DoD performs its business activities in the future. This model is expected to serve as an integrating context model for all models developed in more levels of detail.

The DoD Enterprise model has been constructed from the viewpoint of the Secretary of Defense (SECDEF) who, in his position, has the requisite power and authority delegated to him by the President, within law and policy established by Executive, Judicial, and Congressional authorities, to develop the necessary Defense policy, guidance, assets, and forces, to respond to current and future world situations and enable the DoD to successfully perform its mission.

USED AT	AUTHOR : ASD_C3I/IM	DATE : 10/07/92	WORKING	READER	DATE	CONTEXT
	PROJECT : ENTERPRISE	REV. : 07/06/94	DRAFT			
	COMPANY : DOD		X RECOMMENDED			
	NOTES : X Z 3 4 5 6 7 8 9 10		PUBLICATION			

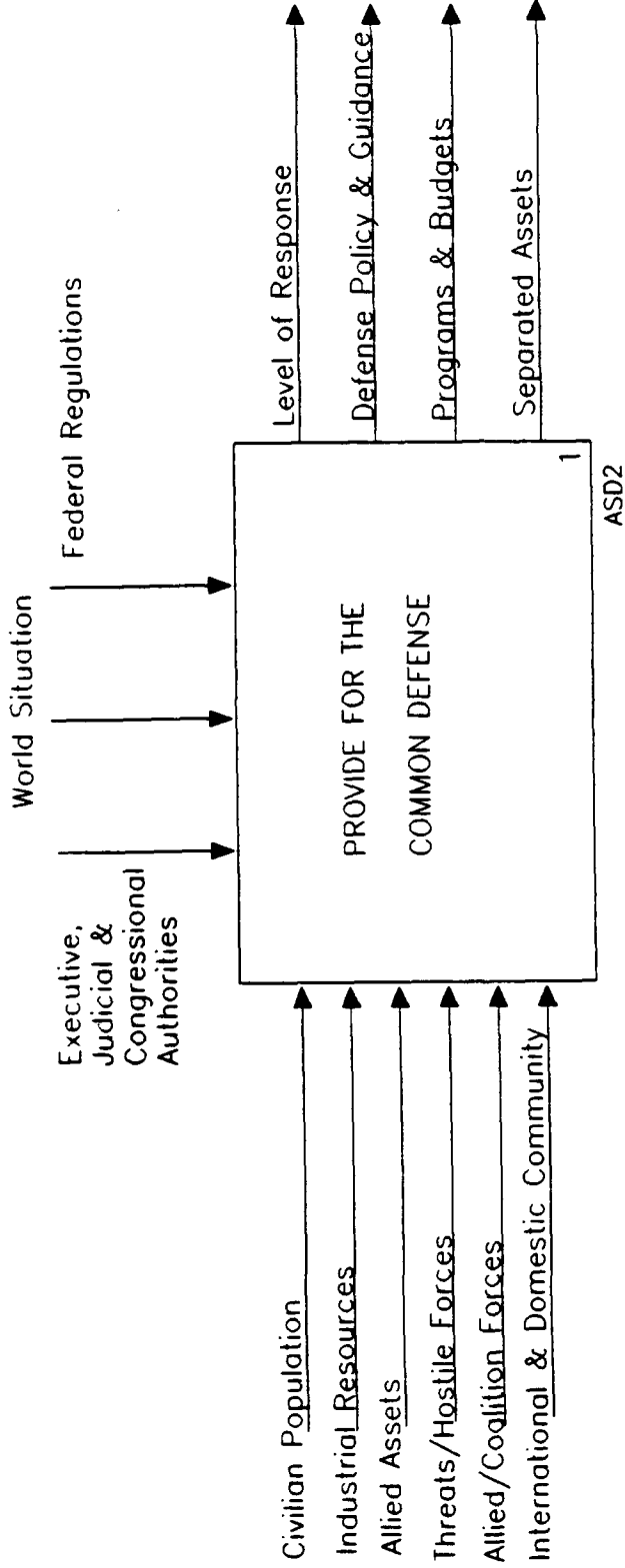

1 VIEWPOINT: Secretary of Defense and civilian and military leaders authorized to carry out missions in support of the National Security and Military Strategies.

2 PURPOSE: To develop the standard frame of reference for identifying improvement opportunities, anticipating the impact of management, process, and technology improvements, and making useful changes.

CODE: AS-15/A-0	TITLE: PROVIDE FOR THE COMMON DEFENSE (VERSION 2.0)	NUMBER: ASD1
-----------------	---	--------------

## **AO PROVIDE FOR THE COMMON DEFENSE**

The DoD Enterprise Model consists of four major activities. Together, these four activities make up the Defense enterprise.

**Establish Direction** provides the strategic vision, goals, objectives, policies, strategies, requirements, plans and programmed resources that are executed in the other three activities.

**Acquire Assets** obtains the products, services, and people needed for defense missions.

**Provide Capabilities** integrates assets into organizations and units which are developed into ready capabilities to conduct missions and provide infrastructure support in peacetime, transition, and war.

**Employ Forces** uses forces to accomplish assigned missions. It is the "bottom-line" delivery of the capability to defend the nation, keep the peace worldwide, and assist people in need as directed by the National Command Authority.

USED AT	AUTHOR : ASD_C3I/IM	DATE: 10/07/92	WORKING	READER	DATE	CONTEXT	ASD1
	PROJECT : ENTERPRISE	REV : 07/06/94	DRAFT				
	COMPANY: DOD		X RECOMMENDED				
	NOTES : 1 2 3 4 5 6 7 8 9 10		PUBLICATION				A-0

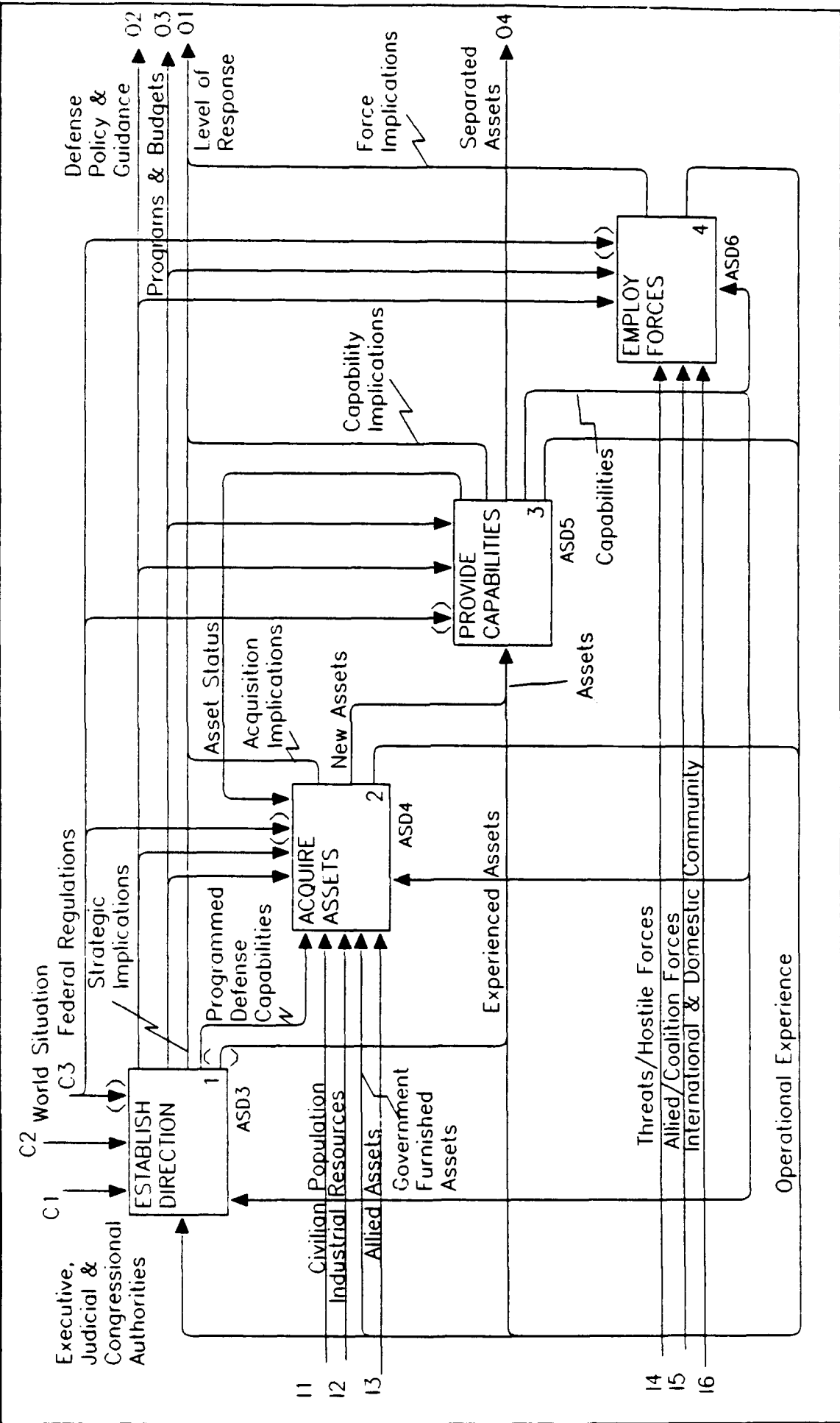

MODE: AS-IS/AO	TITLE: PROVIDE FOR THE COMMON DEFENSE (VERSION 2.0)	NUMBER: ASD2
----------------	---	--------------

## **A1 ESTABLISH DIRECTION**

This major activity of the defense enterprise establishes the mission, goals, objectives, strategies, requirements, plans, and resources for the Department of Defense (DoD). National security interests, developed to be consistent with and in support of national values and priorities, are integrated into defense policy, guidance, plans, and programs. There are four activities in **Establish Direction**:

**Establish Policy** assesses the world situation for threats to peace and welfare, establishes the national security strategy of the United States<sup>2</sup>, and establishes defense priorities and strategies that guide and direct the definition of requirements, development of plans, and allocation of resources within the DoD. The context for the National Security Strategy and the National Military Strategy is established through the interaction of the Executive Branch — to include the DoD, Department of State, Central Intelligence Agency, and the Office of Management and Budget — and the Congress and the Judicial Branch.

**Determine Requirements** assesses the actual capabilities of the US, as demonstrated by the performance of forces in action and the outcomes of defense programs. As a result of this assessment, deficiencies in the current defense baseline are identified. Opportunities to improve doctrine, force structures, other organization capabilities, and assets (e.g., weapons, people) are analyzed for their suitability and realism. The requirements for modernization, force structure, sustainment, and readiness are determined through this activity.

**Develop Plans** develops military plans and resource/management plans within the context of the Joint Strategic Planning System (JSPS) for warfighting plans, and the Planning, Programming, and Budgeting System (PPBS) for resources. All plans of the Department are produced in this activity, based on civilian and military requirements. Conversely, planning generates new requirements and impacts on policy (e.g., determines the limits of policy).

**Allocate Resources** develops resource needs into programs submitted as Program Objective Memoranda (POMs). Resource needs are consolidated to align timing, eliminate duplication, and establish integrated priorities. The Defense Planning and Resources Board (DPRB) reviews issues and determines a final position in the Budget Estimate Submission (BES) which is incorporated in the Defense Budget. The Defense Budget is submitted as part of the President's Budget to Congress for authorization and appropriation.

USED AT	AUTHOR : ASD_C3I/IM	DATE : 10/07/92	WORKING	READER	DATE	CONTEXT ASD2
	PROJECT : ENTERPRISE	REV : 07/06/94	DRAFT			
	COMPANY : DOD		X RECOMMENDED			
	NOTES : 1 2 3 4 5 6 7 8 9 10		PUBLICATION			AO

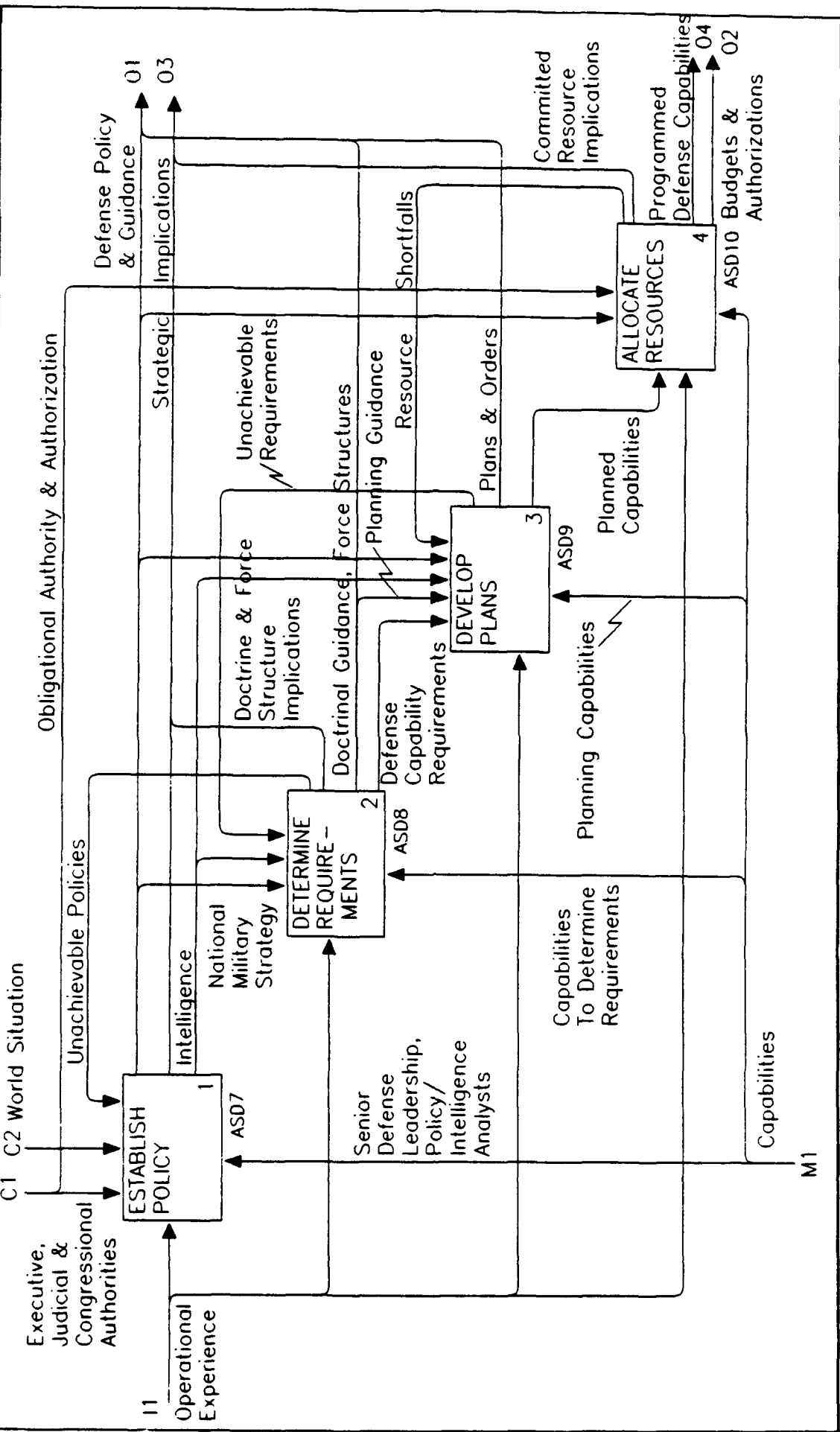

NODE: AS-IS/A1	TITLE: ESTABLISH DIRECTION (VERSION 2.0)	NUMBER: ASD3
----------------	--	--------------

## **A11 ESTABLISH POLICY**

This activity assesses the world situation for threats to peace and welfare, establishes the National Security Strategy and the National Military Strategy of the US, and establishes defense priorities and strategies that guide and direct the definition of requirements, development of plans, and allocation of resources within the DoD. The context for the National Security Strategy and the National Military Strategy is established through the interaction of the Executive Branch — to include the DoD, Department of State, Central Intelligence Agency, and the Office of Management and Budget — and the Congress and the Judicial Branch. There are three activities in **Establish Policy**:

**Assess World Situation** monitors global and regional situations for actual and potential threats to US interests and goals. Indications and warnings are tracked, and national intelligence assets are ordered to focus on specific situations, events, and areas of concern to the National Command Authority (NCA). Political, economic, and military information is gathered, fused, and analyzed to determine trends, estimate intentions, and assess the capabilities of adversaries. Natural and manmade disasters, terrorist actions, international drug trafficking activities, and civil disorders are closely followed and their significance to US interests is assessed.

The status and location of US forces and resources are monitored to provide the NCA and military commanders with a reliable, timely understanding of US capabilities, as well as to comply with Congressional reporting requirements and public law. Status reporting is increased, as necessary, in crisis and war. This activity also continually tracks global weather, terrain, and oceanographic conditions.

**Establish National Security Priorities** develops national security priorities, goals, and strategies based upon US interests, expectations of the world community, agreements, and the world and domestic situation. The defense leadership, through the Secretary of Defense and the Chairman of the Joint Chiefs of Staff (JCS), participate in formulation of national security policy by providing advice and counsel relating to military threats, strategic military options, US and allied/coalition capabilities, and risks. National security concerns in the post-Cold-War era include maintaining international peace and order, ensuring economic security, promoting and securing democracy around the world, preventing proliferation of weapons of mass destruction, countering international terrorism and drug dealing, and preserving the global environment. Also, the US and the world community are increasingly providing humanitarian help and disaster relief to people in need, in circumstances that require the use of military forces to deliver assistance.

USED AT	AUTHOR : ASD_C31/IM	DATE : 10/27/92	WORKING	READER	CONTEXT	ASD3
	PROJECT : ENTERPRISE	REV. : 07/06/94	DRAFT		<input type="checkbox"/>	
	COMPANY : DOD		X RECOMMENDED		<input type="checkbox"/>	
	NOTES : 1 2 3 4 5 6 7 8 9 10		PUBLICATION		<input type="checkbox"/>	A1

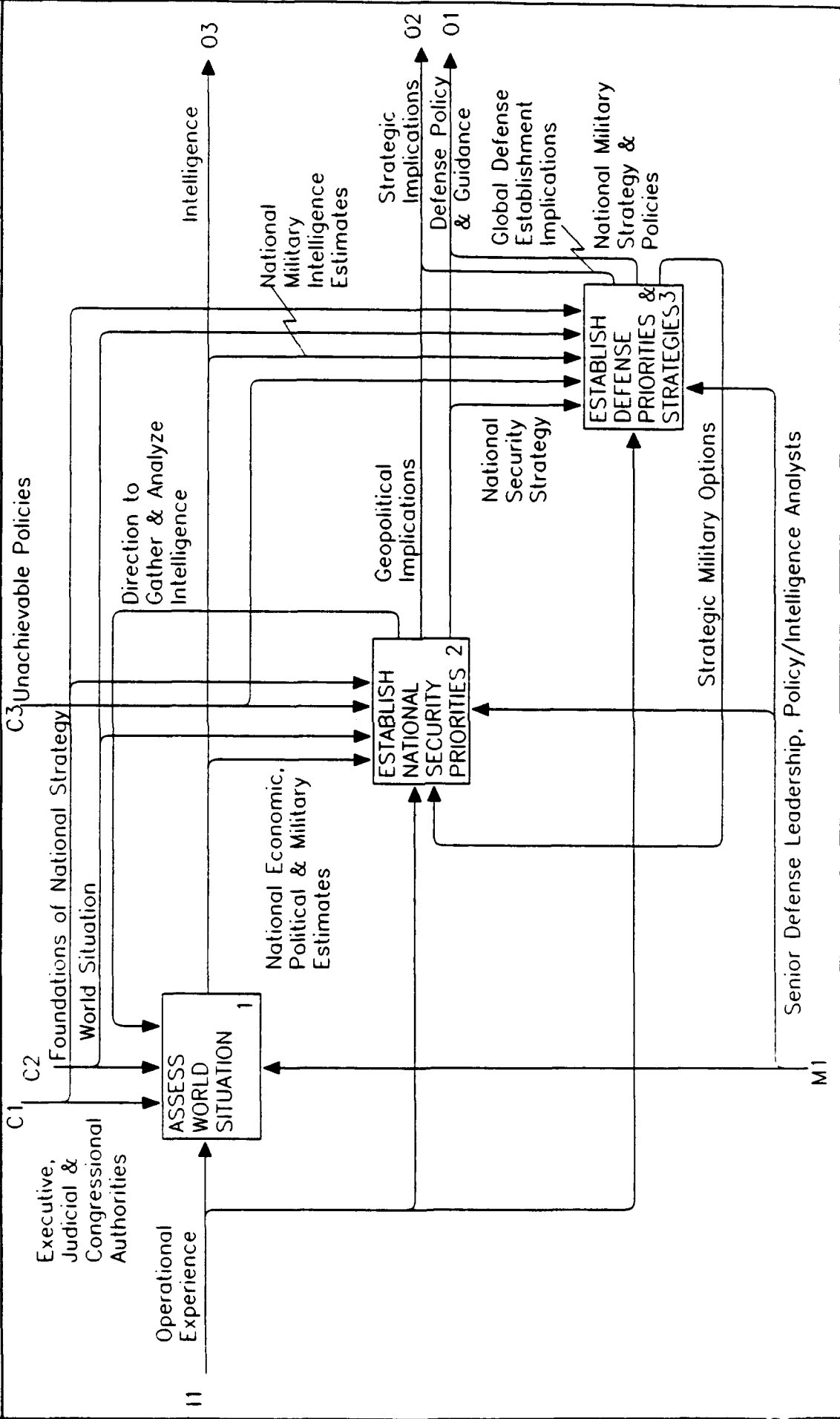

MODE: AS-IS/A11	TITLE: ESTABLISH POLICY (VERSION 2.0)	NUMBER: ASD7
-----------------	---------------------------------------	--------------

This activity integrates legislative requirements and statutory programs mandated by Executive, Judicial and Congressional authorities into defense guidance (e.g., acquisition regulations). International agreements (e.g., alliances and host-nation support), emergency authorities (e.g., for mobilizations), and political/military/economic constraints are established. The National Security Strategy of the US and the National Security Decision Directives are the top-level guidance that result from this activity.

**Establish Defense Priorities & Strategies**, led by the Secretary and Chairman, responds to national security guidance by developing global and regional military missions, strategic vision, goals and objectives, and measures of performance; preparing, assessing and recommending strategic military options; specifying major missions for the DoD (e.g., deterrence, peacekeeping); recommending required host-nation support; assessing US capabilities and needs; and generally advising the NCA and the Congress on military matters. The National Military Strategy of the US is produced from this activity. Defense Planning Guidance (DPG) is issued by the SECDEF to guide requirements and planning activities (see below). Subordinate elements of the Department issue guidance for their areas of responsibility consistent with the DPG.

USED AT	AUTHOR : ASD_C3I/IM	DATE : 10/27/92	WORKING	READER	DATE	ONTEXT	ASD3
PROJECT : ENTERPRISE	REV : 07/06/94		DRAFT			<input type="checkbox"/>	
COMPANY : DOD			<input checked="" type="checkbox"/> RECOMMENDED			<input type="checkbox"/>	
NOTES : 1 2 3 4 5 6 7 8 9 10			PUBLICATION			<input type="checkbox"/>	A1

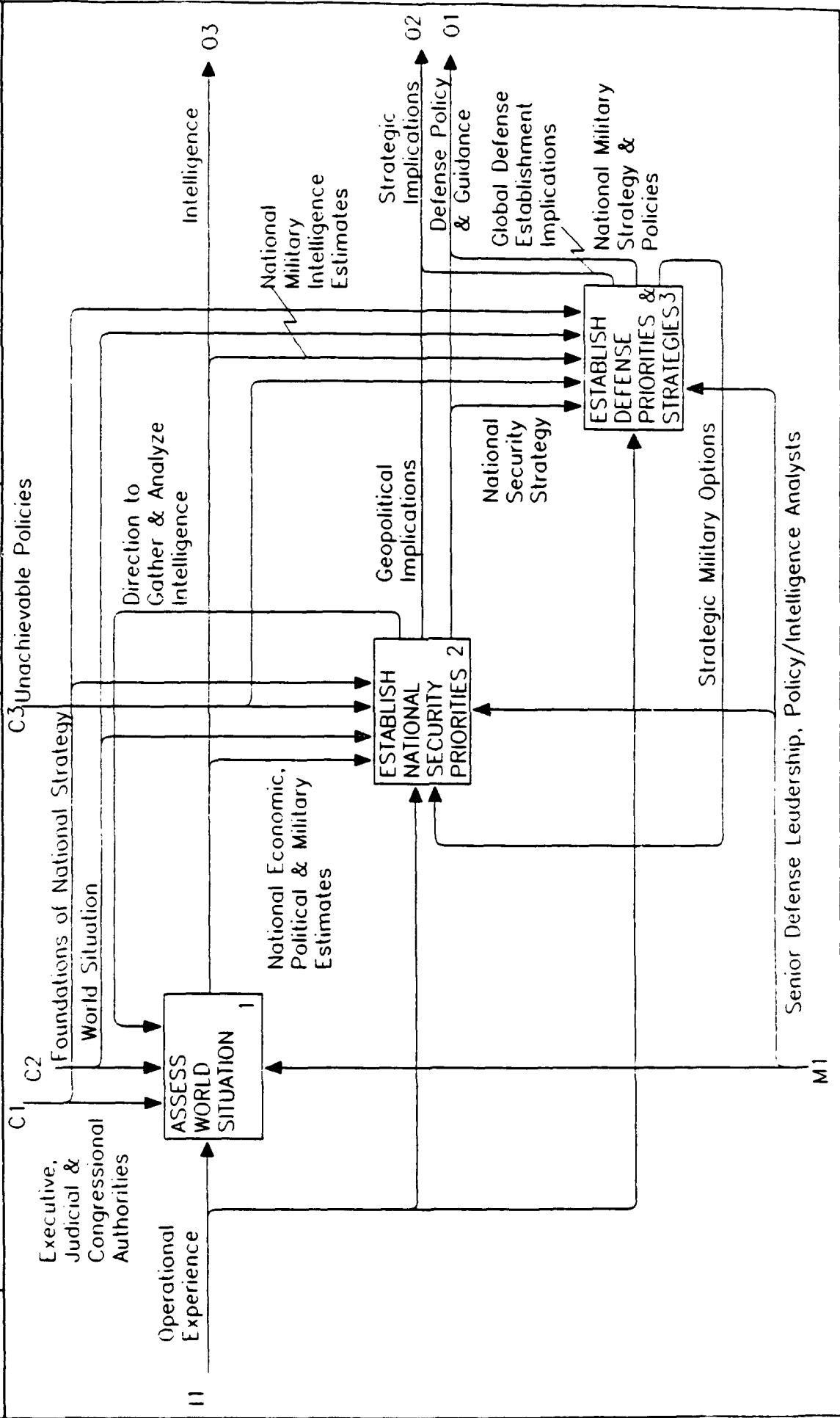

MODEL : AS-15/A11	TITLE : ESTABLISH POLICY (VERSION 2 0)	NUMBER : ASD7
-------------------	--	---------------

## A12 DETERMINE REQUIREMENTS

This activity assesses the actual capabilities of the US, as demonstrated by the performance of forces in action and the outcomes of Defense programs. As a result of this assessment, deficiencies in the current defense baseline are identified. Opportunities to improve doctrine, force structures, other organization capabilities, and assets (e.g., weapons, people) are analyzed for their suitability and realism. The requirements for modernization, force structure, sustainment and readiness are determined through this activity. There are four activities in **Determine Requirements**:

**Evaluate Capabilities & Performance** assesses the actual performance of the Department against the threat and national objectives in order to determine overall requirements for improvement. DoD policy is to re-engineer and continuously improve its methods, processes, data, and information systems. At all levels the outcome of defense activities — operational experience — is evaluated to determine success or failure. After-Action Reports (AARs) are used to generate lessons learned from operations in the field. For peacetime exercises, force performance is measured against training standards. Resource and management programs that require assets and provide support capabilities are also assessed against established goals and metrics. These evaluations are the feedback needed to improve the defense activity. They are disseminated to commanders, managers, and analysts to affect policies, doctrine (strategic, operational, and tactical), force structures, unit/organizational training methods and measures, materiel, personnel, and systems requirements. Mission Need Statements (MNS) identify capability deficiencies and unmet requirements.

**Develop Doctrine** examines current doctrine and evolves improved doctrine and procedures. Joint Pub 1, *Joint Warfare of the US Armed Forces*, issued by the Chairman of the Joint Chiefs of Staff, sets the doctrinal stage for integrating service units into effective joint fighting forces. Nested within joint warfighting doctrine are the Service doctrines for common and unique functions. Potential doctrinal changes are validated for their practicality and suitability to future missions and operational scenarios. The structures and capabilities of defense organizations are aligned with new or modified doctrine and Departmental procedures for support. Commands, Services, agencies, and other organizations work in concert to execute DoD warfighting, peacekeeping, humanitarian, and other missions.

**Structure Organizations & Forces** develops improved military and supporting organizations. Force structures provide the core defense capability to conduct operations. Their design evolution involves integrating changes to doctrine, weapons, people, and support, over time, to achieve a "best" balance of operational performance across the full spectrum of anticipated missions. Force structure design is the basis for asset and support requirements. Conversely, the ability to provide the right

USED AT	AUTHOR : ASD_C3/IM	DATE : 10/27/92	WORKING	READER	DATE	CONTEXT	ASD3
	PROJECT : ENTERPRISE	REV : 07/06/94	DRAFT				
	COMPANY : DOD		X RECOMMENDED				
	NOTES : 1 2 3 4 5 6 7 8 9 10		PUBLICATION				A1

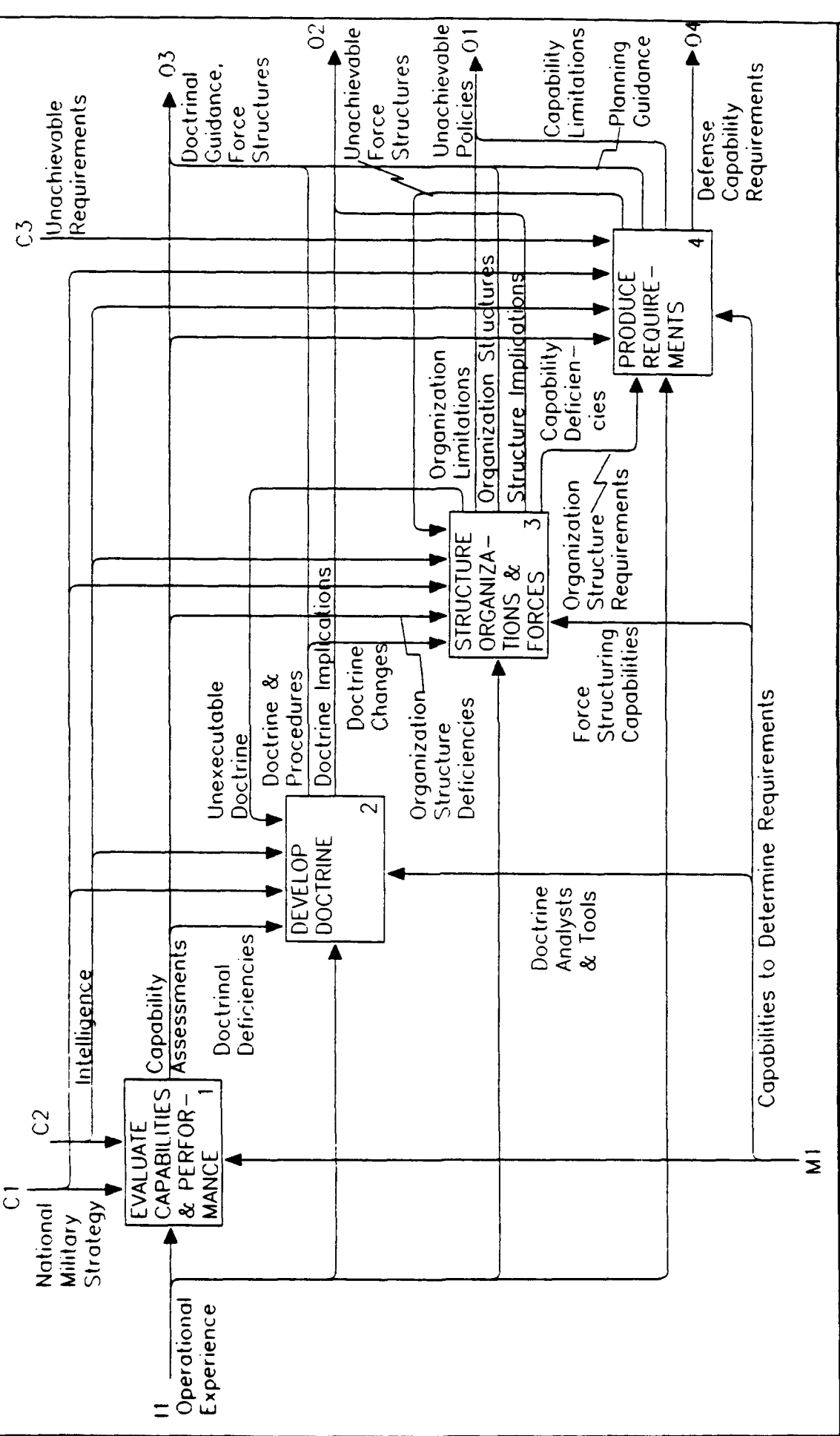

MODE : AS-15/A12	TITLE : DETERMINE REQUIREMENTS (VERSION 2.0)	NUMBER : ASD8
------------------	--	---------------

assets and deliver support to forces constrains the force structure envelope. In the post-cold war environment, new approaches such as reconstitution offer opportunities to anticipate, avert, and respond to threats by ensuring a capability for building up the force, over time. Other organizational requirements enter into resource/management programs from the routine support and administration of the Department.

**Produce Requirements** develops asset requirements to support doctrine and organization/force structure. For example, it develops the operational parameters of new weapon systems. Materiel, personnel, and other asset requirements are expressed in terms of operational performance, as well as timing and cost envelopes. Specific capability requirements are defined through Required Operational Capabilities (ROCs), Operational Requirement Documents (ORDs), and other requirements documents.

USED AT	AUTHOR : ASD C3I/IM	DATE : 10/27/92	WORKING	READER	CONTEXT ASD3
	PROJECT : ENTERPRISE	REV : 07/06/94	DRAFT		
	COMPANY : DOD		X RECOMMENDED		
	NOTES : 1 2 3 4 5 6 7 8 9 10		PUBLICATION		A1

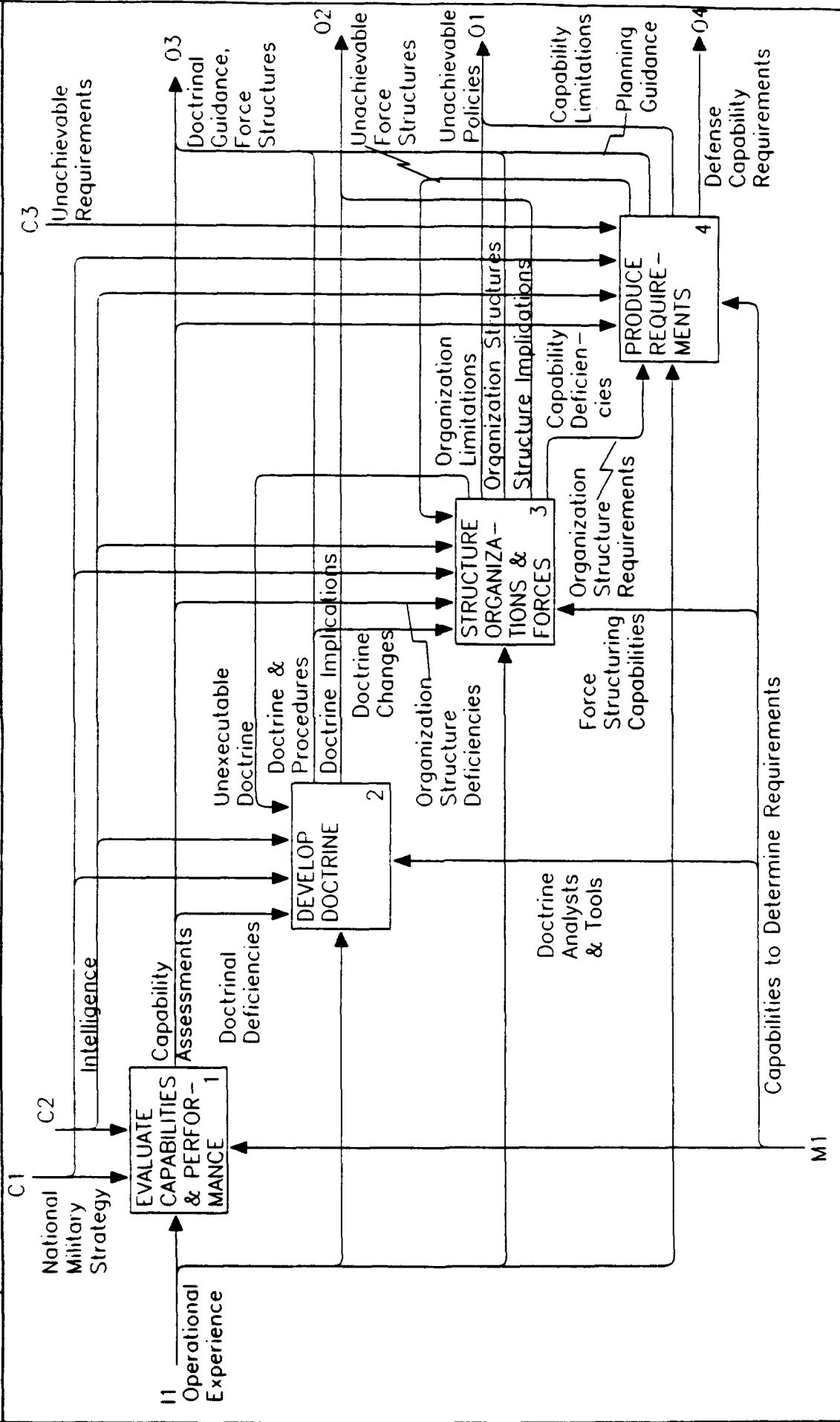

NODE: AS-IS/A12	TITLE: DETERMINE REQUIREMENTS (VERSION 2 0)	NUMBER: ASD8
-----------------	---	--------------

## A13 DEVELOP PLANS

This activity develops military plans and resource/management plans within the context of the Joint Strategic Planning System (JSPS) for warfighting plans, and the Planning, Programming, and Budgeting System (PPBS) for resources. All plans of the Department are produced in this activity, based on civilian and military requirements. Conversely, planning generates new requirements and impacts on policy (e.g., determines the limits of policy). The Goldwater-Nichols Reorganization Act of 1986 (Public Law 99-433) calls for reconciling strategy and military requirements with available resources, thus explicitly recognizing the need for integrating military planning with program planning in a constrained resource environment. This activity also produces the plans formulated in response to statutory and legislative requirements and the standards for evaluating plan performance (e.g., occupational safety and health, environmental protection, technology transfer, and survivor's benefits).

Military planning addresses both deliberate and crisis situations. The fundamental difference is in the sequencing, timing, and depth of detail in the planning process. Detailed plans, including Operation Plans (OPLANs), support plans and annexes, and mobilization plans are usually prepared to meet future contingencies and are "put on the shelf" until needed. Crisis planners may use "on the shelf" contingency plans by tailoring them for the immediate situation or by developing new plans.

Exercises are planned to support the Joint Strategic Capabilities Plan (JSCP) strategy and plans. Typically, an exercise is initiated through a Significant Military Exercise Brief (SMEB), approved by the Chairman, JCS, resulting in a deployment order. There are four activities in **Develop Plans**:

**Identify Objectives/Missions** reviews strategic guidance such as the JSCP and the DPG, and assessments of the situation. As a result, military commanders and Department managers identify and reconcile missions and objectives. Objectives specify targets against which progress (success or failure) of defense activities are evaluated. Tasking guidance, such as the JSCP and the Warning Order issued by the Chairman of the JCS, establishes the boundaries that constrain planning.

**Develop Courses of Action**, performed by supported and supporting commanders and their staffs, develops options and alternative Courses of Action (COAs) for accomplishing mission objectives. Department managers also develop options for acquiring assets and providing support capabilities. Options are assessed for their suitability, feasibility, acceptability,

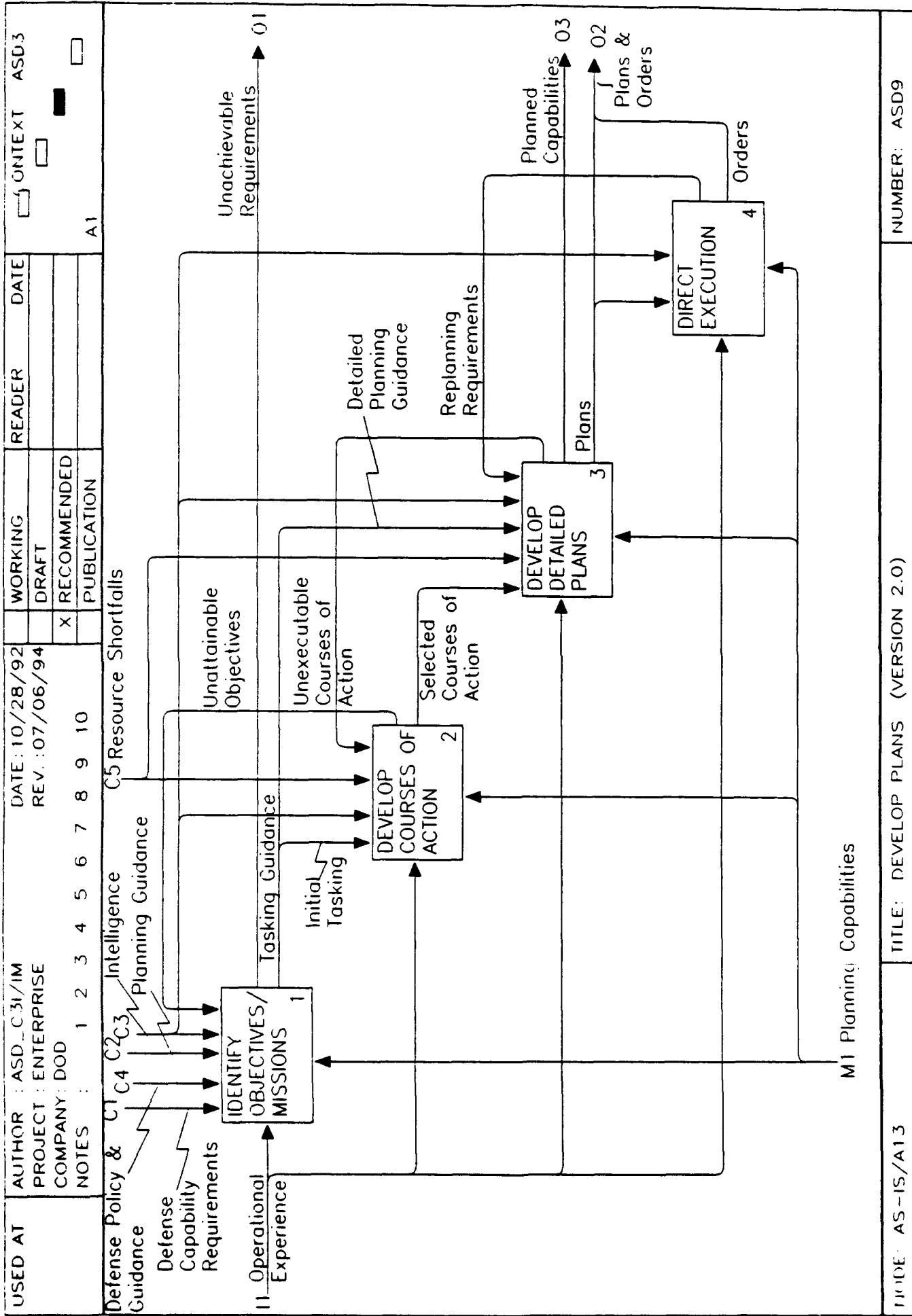

NUMBER: ASD9

TITLE: DEVELOP PLANS (VERSION 2.0)

NUMBER: ASD9

consistency with Joint Doctrine, and risk. Based on the estimate of the situation, decision-makers review and approve recommended options/COAs and issue detailed planning guidance. The selected COA becomes the basis for subsequent development of a detailed, executable plan.

**Develop Detailed Plans** guides, develops, integrates and approves detailed (executable) plans that support military missions and capability requirements. Forces are assigned for use and apportioned for planning to combatant commands to support their missions in accordance with the JSCP. Organizations that are responsible for planning (e.g., Commands, Services, agencies) develop source plans with actual units and assets. Allocation is performed within approved authorizations. Often there are shortfalls in available resources that must be resolved through re-planning or re-allocations, or be programmed for new capabilities at successive levels in the planning hierarchy. These shortfalls may, in fact, place limits on forces and doctrine and can impact policy.

Availability of host-nation support established through treaties and agreements (e.g., NATO) is part of the integrated planning, requirements, and policy process for each scenario. For example, support needs may be fulfilled through programmed US capabilities, mobilization of US assets, or specific agreements with other nations.

**Direct Execution** provides Operation Orders (OPORDs) that contain the necessary information for execution. The National Command Authority authorizes the Chairman, JCS to issue an Execute Order to commanders to initiate operations. Comparative analysis is performed to determine the need for re-planning and new orders based on operational experience. Other orders terminate operations.

For acquisition, planning guidance establishes the relationships among requirements and the following activities of PPBS and acquisition management. On the resource/management side, planning leads into the programming and budgeting stages of the PPBS, which are described below.

USED AT	AUTHOR : ASD_C3I/IM	DATE : 10/28/92	WORKING	READER	DATE	ONLIXT	ASD3
	PROJECT : ENTERPRISE	REV : 07/06/94	DRAFT			<input type="checkbox"/>	
	COMPANY : DOD		<input checked="" type="checkbox"/>	RECOMMENDED		<input type="checkbox"/>	
NOTES :	1 2 3 4 5 6 7 8 9 10		PUBLICATION				A1

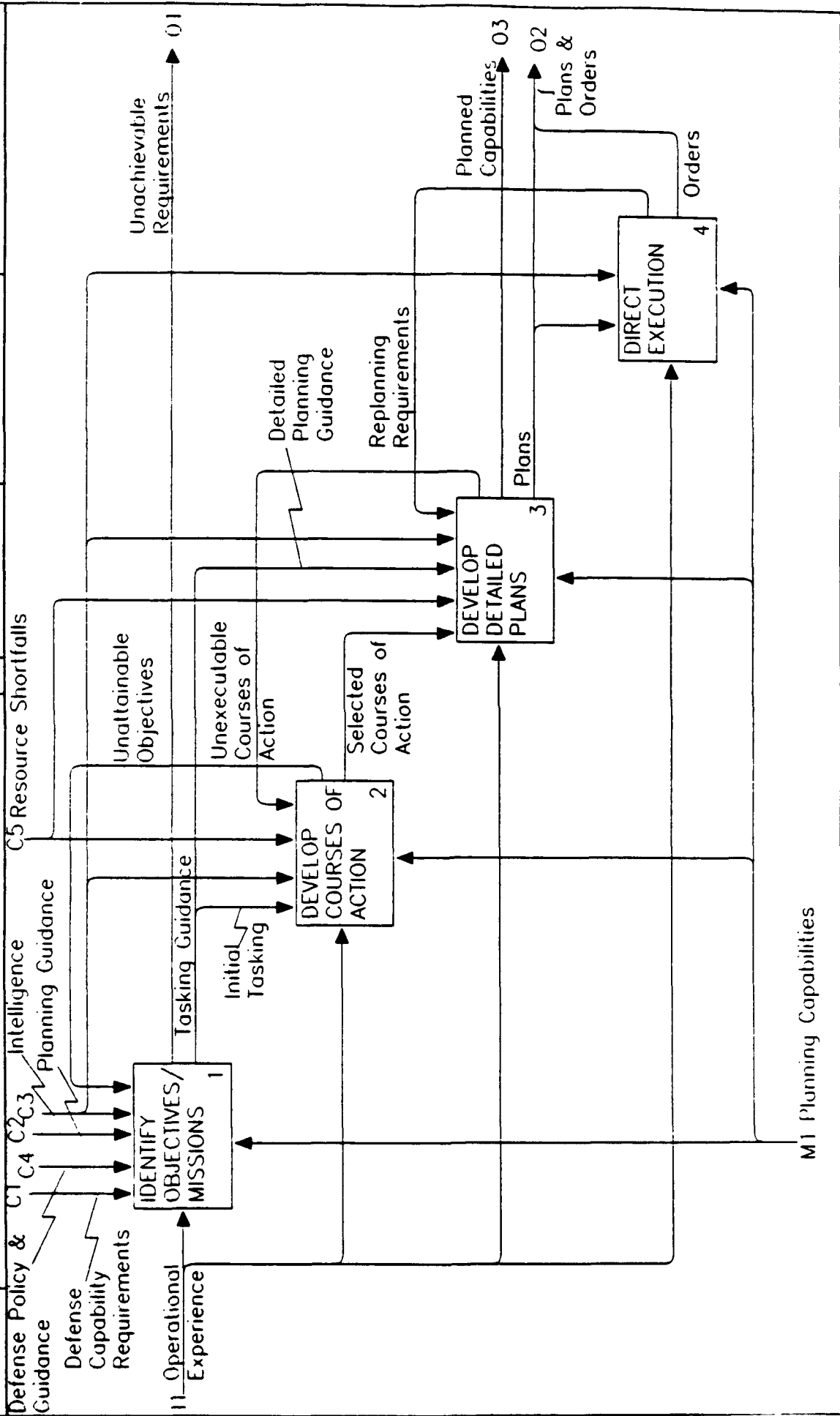

MODE : AS-15/A13	TITLE : DEVELOP PLANS (VERSION 2.0)	NUMBER : ASD9
------------------	-------------------------------------	---------------

## A14 ALLOCATE RESOURCES

This activity develops resource needs into programs submitted as Program Objective Memoranda (POMs). It includes the Programming and Budgeting phases of the PPBS. The PPBS is the single mechanism to develop funding/authorization levels and force allocations of the Department relative to the capabilities and timing requirements established in the previous activities that respond to the DPG. Resource needs are consolidated to align timing, eliminate duplication, and establish integrated priorities. The Defense Planning and Resources Board (DPRB) reviews issues and determines a final position in the Budget Estimate Submission (BES) which is incorporated in the Defense Budget. The Defense Budget is submitted as part of the President's Budget to Congress for authorization and appropriation. There are three activities in **Allocate Resources**:

**Develop Programs/Budgets** develops specific programs to acquire assets, manage assets and capabilities, and conduct operations. The Military Departments and Defense agencies transmit their proposed resource needs in POMs. Commander in Chief (CINC) Integrated Priority List (IPL) requirements are addressed by the Services in the POMs.

**Consolidate & Prioritize** assesses the proposed programs for operational effectiveness, priorities, timing, and risk. The PPBS process provides for a Chairman's Program Assessment (CPA) that assesses the risks inherent in the composite force proposed in the Service and Defense Agency POMs. OSD reviews the Service's POMs and the CPA, and identifies alternatives for those issues in which OSD differs with the Service approach.

**Balance Programs/Budgets** addresses issues through the Defense Planning and Resources Board (DPRB), resulting in final positions announced via Program Decision Memoranda (PDM). Revised POMs are then transformed into Service Budget Estimate Submissions (BESs). A DPRB Budget Review culminates in Program Budget Decisions (PBDs) which are incorporated into the Defense Budget. The Future Years Defense Program (FYDP) records the resourced position of the Department including each Service's submissions in terms of personnel, equipment, training, and acquisition in support of the National Military Strategy. The FYDP reflects the "best" program balance between current force readiness, institutional modernization, force structure, and the ability to sustain current and programmed future forces.

It is this resourced program that is consolidated into the President's Budget and forwarded along with detailed budgets for the next years to the Congress for approval. Approval to expend monies on specific programs comes through the Defense Appropriation legislation. Quantities of personnel and materiel are also approved for specific programs through the Defense Authorization legislation.

USED AT	AUTHOR : ASD_C31/IM	DATE: 01/21/93	WORKING	READER	DATE	CONTEXT	ASD3
	PROJECT : ENTERPRISE	REV. : 07/06/94	DRAFT			<input type="checkbox"/>	
	COMPANY : DOD		<input checked="" type="checkbox"/> RECOMMENDED			<input type="checkbox"/>	
	NOTES : 1 2 3 4 5 6 7 8 9 10		PUBLICATION				A1

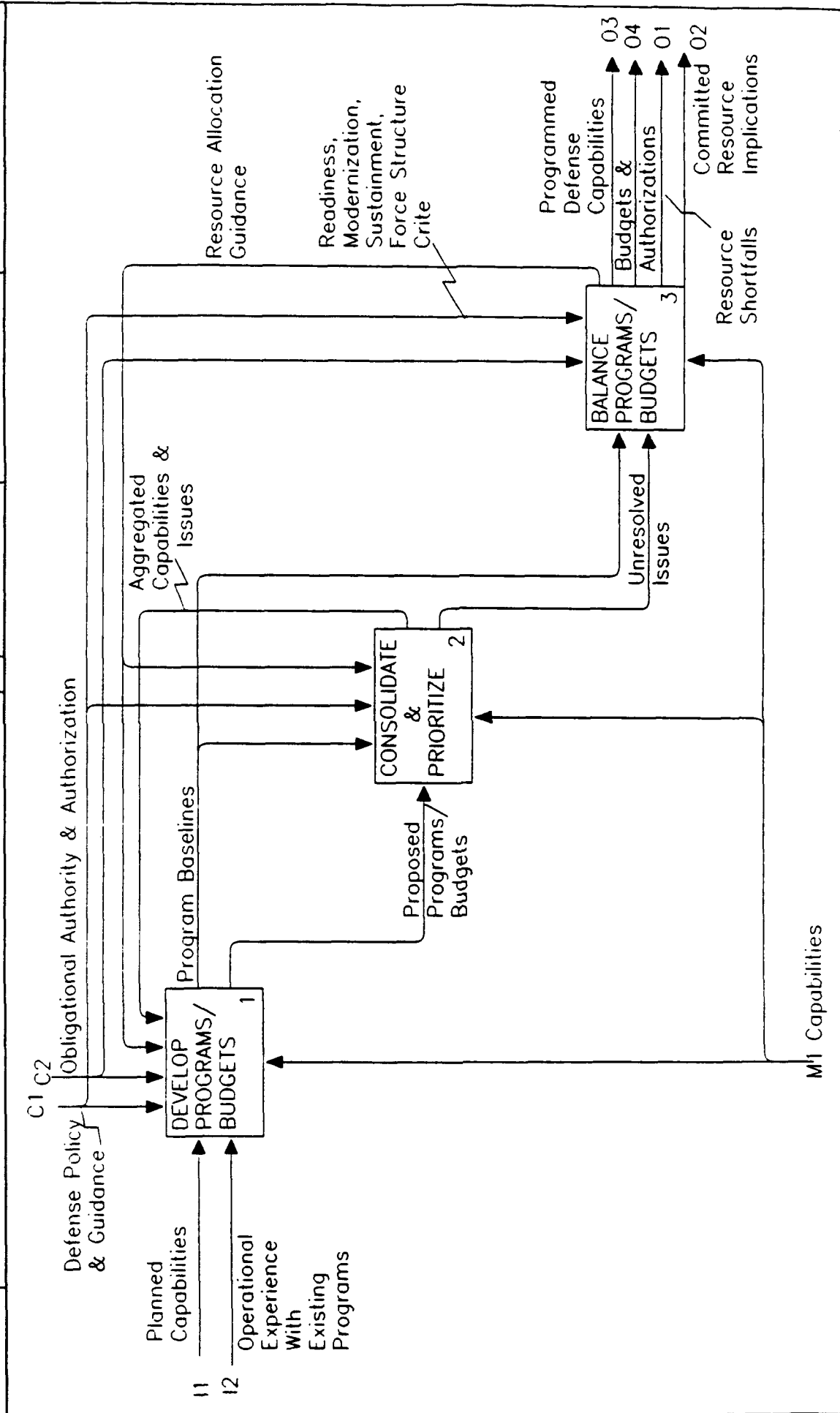

MODE: AS-IS/A14	TITLE: ALLOCATE RESOURCES (VERSION 2.0)	NUMBER: ASD10
-----------------	---	---------------

The resourced position of the FYDP, as approved through the budget and appropriation/authorization process, is documented for execution by the Office of the Secretary of Defense, the Defense Agencies, and Military Departments by the manpower/unit authorization documents (e.g., The Army Authorization Document System (TAADS) for the Army) for battalions/separate companies, ships, and aircraft squadrons. Approved programs and budgets contain resourced operating tempos (OPTEMPOs — such as ship and submarine steaming hours, aircraft and helicopter flying hours, or tactical vehicle miles driven) for peacetime levels of unit training to achieve acceptable levels of unit/force readiness and organizational proficiency. These are the resource positions that fund execution of the other major activities of the enterprise: **Acquire Assets, Provide Capabilities and Employ Forces.**

USED AT	AUTHOR : ASD_C3I/IM	DATE : 01/21/93	WORKING	READER	DATE	CONTEXT	ASD3
	PROJECT : ENTERPRISE	REV : 07/06/94	DRAFT				
	COMPANY : DOD		X RECOMMENDED				
	NOTES : 1 2 3 4 5 6 7 8 9 10		PUBLICATION				A1

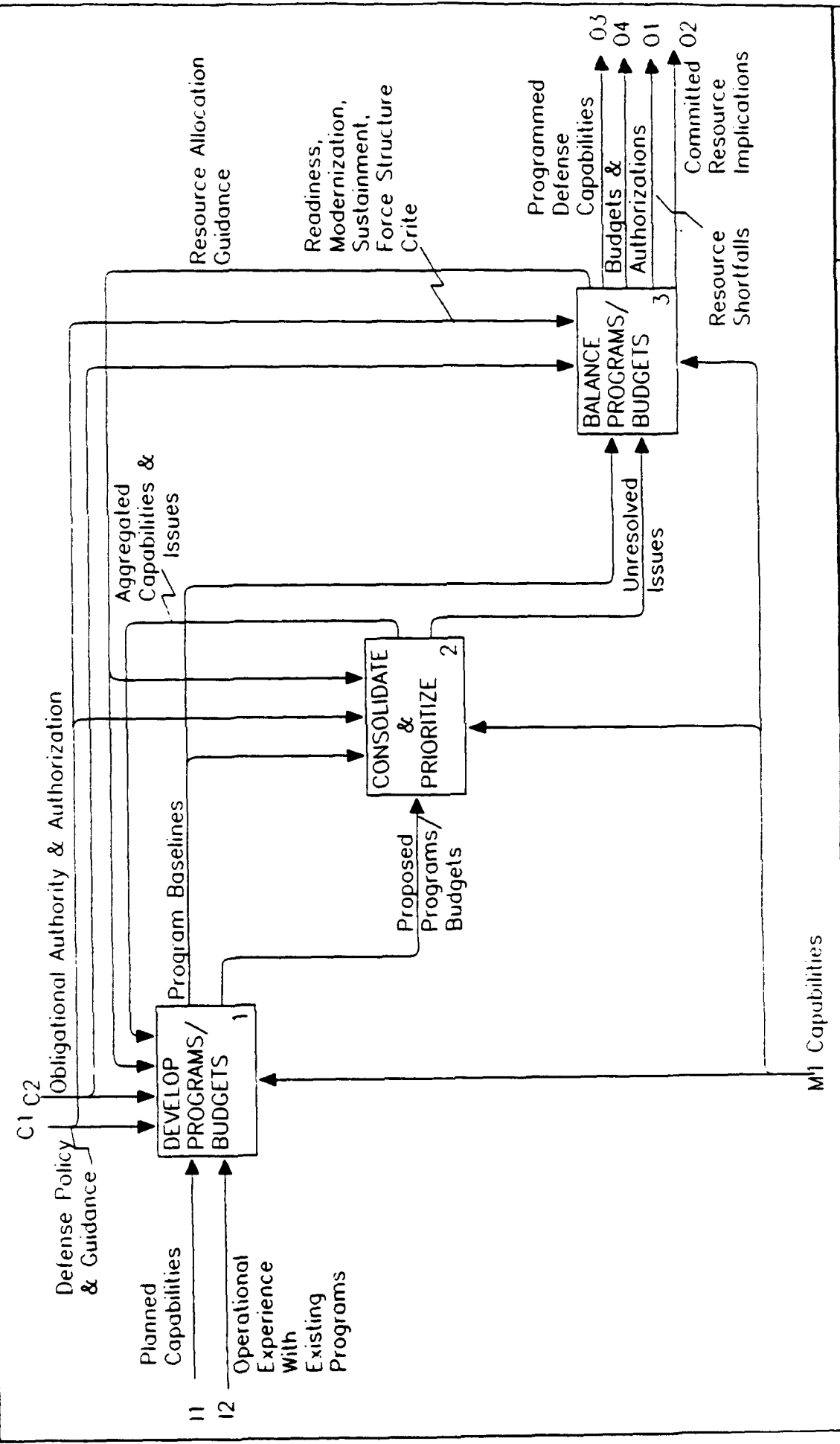

MODEL : AS-IS/A14	TITLE : ALLOCATE RESOURCES (VERSION 2 0)	NUMBER : ASD10
-------------------	--	----------------

## A2 ACQUIRE ASSETS

This major activity of the defense enterprise obtains assets to support requirements, bounded by the resources, timing, and force structures established in the previous major activity, **Establish Direction**. Assets are defined as those people, goods, and services for which the Department expends monies and receives civilian and military personnel, materiel items of inventory, facilities, real estate, and services or some other specified deliverable that will be managed by the Department.

Acquisition of assets includes the detailed reconciliation of requirements to include the assessment of available goods and services, acquisition of technology and developmental items, purchasing, manufacturing, testing, and any preparation necessary to ensure delivery of a useable asset through the asset distribution systems (e.g., personnel, equipment). Therefore, for example, accession training for military personnel is included in this activity. There are three activities in **Acquire Assets**:

**Manage Acquisition** defines and promulgates regulations, policies, and procedures; defines procurements; and conducts the procurements.

**Research & Design** includes the conduct of research, design, and testing to advance the state of the art and to define performance requirements and physical characteristics of assets to be produced. It also validates that the designs and resultant products comply with the requirements.

**Produce Asset** results in manufactured items unique to DoD requirements; the construction of facilities; and the accession of people for both civilian and military billets.

The acquisition process is complete when DoD receives and accepts potential assets or rejects them.

USED AT	AUTHOR : ASD_C31/IM	DATE: 11/02/92	WORKING	READER	DATE	CONTEXT	ASD?
	PROJECT : ENTERPRISE	REV : 07/06/94	DRAFT			<input type="checkbox"/>	<input type="checkbox"/>
	COMPANY: DOD		X RECOMMENDED			<input type="checkbox"/>	<input type="checkbox"/>
	NOTES : 1 2 3 4 5 6 7 8 9 10		PUBLICATION				AD

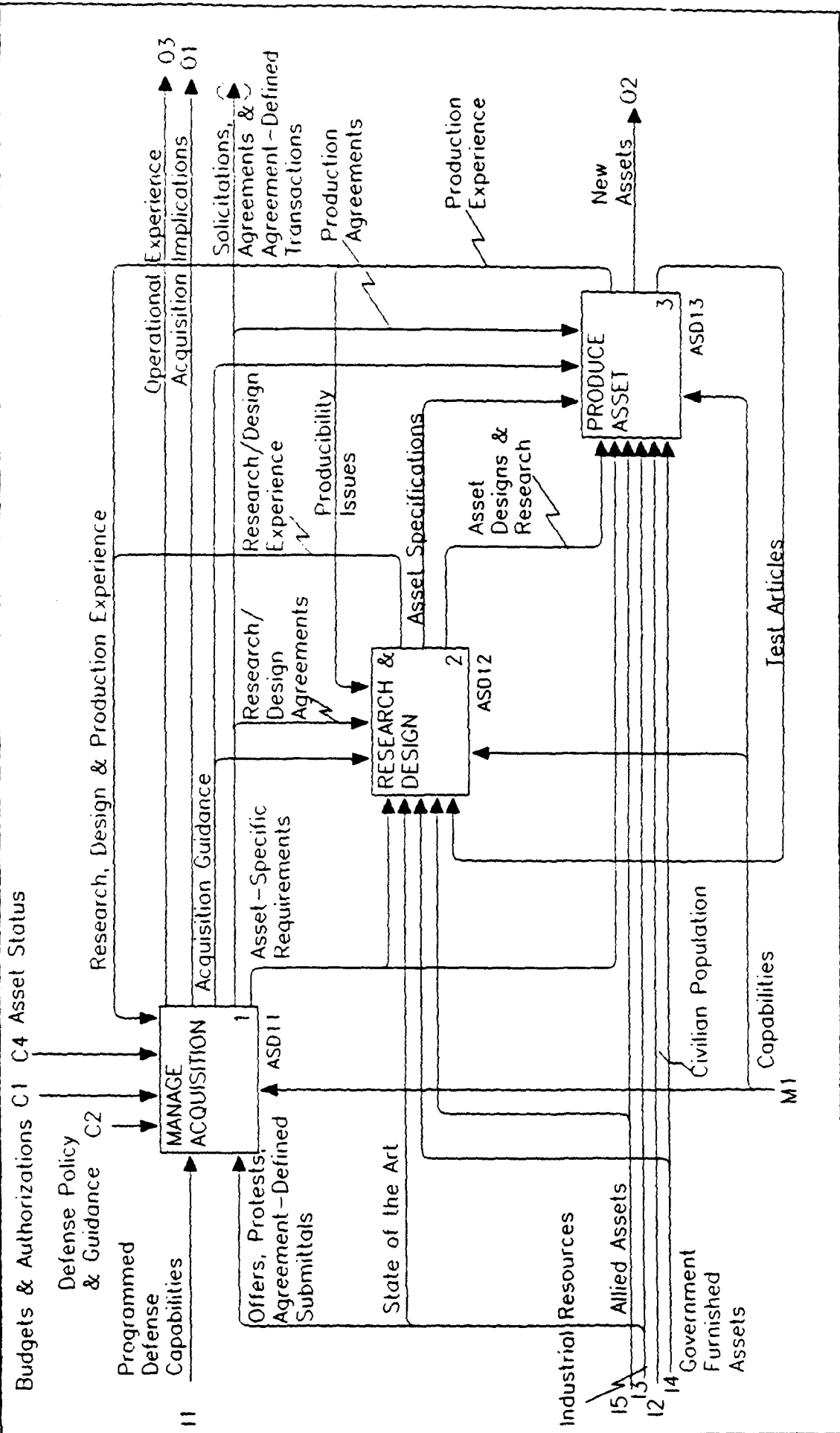

NODE: AS-15/A2	TITLE: ACQUIRE ASSETS (VERSION 2.0)	NUMBER: ASD4
----------------	-------------------------------------	--------------

## A21 MANAGE ACQUISITION

The management of the acquisition process defines and promulgates regulations, policies, and procedures; defines procurements; and conducts the procurements. There are three activities in **Manage Acquisition**:

**Develop Acquisition Guidance** converts Defense Policy and Guidance and Budgets & Authorizations to Acquisition Guidance in the form of Defense Federal Acquisition Regulations (DFARS), Department of Defense Directive 5000.1, and other policies and procedures. It reviews procurement status and provides approval or rejections of acquisition program definitions, procurement plans, and actions brought forward for approval. It converts POM elements and budget line items into requirements. It also establishes procurement processes and procedures.

**Define & Justify Program** analyzes requirements and balances them against the known status of assets that the Enterprise already has in order to define potential mixes of assets to satisfy the requirement and select the best alternative for acquisition programs. Shortfalls are established and program direction is received that specifies the procurement approval criteria and procedures. Proposed programs are submitted for approval.

**Administer Acquisition** includes the activities of Program Managers, Procurement Contracting Officers, Administrative Contracting Officers, their staffs, and supporting technical functions in the conduct of all types of procurements such as managed acquisition programs, small purchasing, research and development, automated data processing equipment, and architecture, engineering and construction. Equivalent personnel process other types of agreements.

It should be noted that assets themselves are not touched by these activities. This is the management of a process that starts with the receipt of requirements and ends by signifying acceptance that the received people, supplies, and services conform to agreement-specified requirements.

USED AT	AUTHOR : ASD, C3I/IM	DATE: 10/28/92	WORKING	READER	DATE	CONTEXT	ASD4
	PROJECT : ENTERPRISE	REV : 07/06/94	DRAFT			<input type="checkbox"/>	
	COMPANY: DOD		X RECOMMENDED			<input type="checkbox"/>	
	NOTES : 1 2 3 4 5 6 7 8 9 10		PUBLICATION				A2

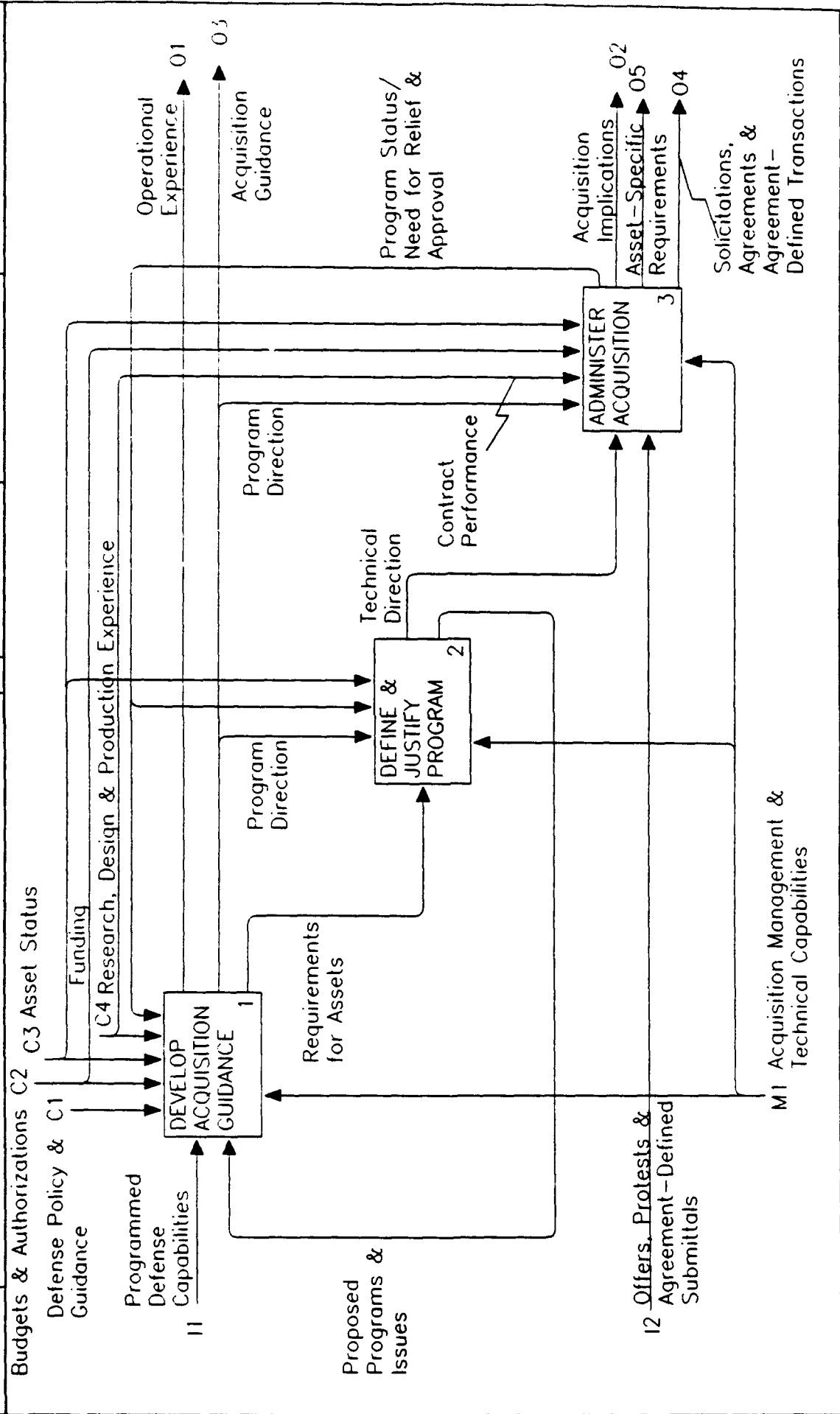

MODF: AS-IS/A21	TITLE: MANAGE ACQUISITION (VERSION 2 0)	NUMBER: ASD11
-----------------	---	---------------

## A22 RESEARCH & DESIGN

This activity conducts research, design, and testing to advance the state of the art, and to define performance requirements and physical characteristics of assets to be produced. It develops standards and specifications and validates that the designs and resultant products comply with the requirements. **Conduct Research** ranges from basic research to advance scientific knowledge to demonstration/validation efforts to prove the value of system technology. **Design** is an iterative process that includes all of conceptual through production design in both the architectural and engineering sense. **Test & Evaluate** includes test planning, the performance of testing, and the evaluation of results. There are three activities in **Research & Design**:

**Conduct Research** includes scientific study and experiments to increase knowledge of the physical, engineering, environmental, and life sciences. It progresses from basic research through exploratory and advanced research to establish the basis for full scale engineering development. Basic research addresses technology and knowledge of potential value to the national security mission as well as the US industrial base. Exploratory development assesses the feasibility and practicality of proposed solutions and standards to military problems short of producing an actual asset. Advanced development produces test assets to prove-out solutions that have potential military applications. Selected programs go through a development phase to reduce the risk associated with technology innovation in a real-world environment. These include Advanced Technology Demonstrations (ATDs).

**Design** is the iterative process of developing designs that specify the form, fit, and function of assets. The possibility of non-developmental items (NDIs) is considered to reduce costs and speed development. Alternative designs are assessed to achieve the best balance of performance, supportability, costs, and risk. Total asset requirements are addressed, including equipment, materiel, facilities, people, and life-cycle support. Manufacturing requirements are considered in the design process to ensure the ability to produce assets. Resource availability (e.g., the labor pool, the part of the electromagnetic spectrum available for defense) is also a key factor in sound designs. The health of the industrial base, US competitiveness, and the ability to reconstitute are integral to the engineering process.

**Test & Evaluate** is the major control mechanism of the **Acquire Assets** activity. Acquisition programs advance from one phase to the next and qualify for major new funding increments by achieving management and oversight thresholds verified by testing and evaluation. In the case of selected program designs, test articles are evaluated. These can be refined until judged ready for production or program termination.

USED AT	AUTHOR : ASD_C3I/IM	DATE : 10/26/92	WORKING	READER	DATE	CONTEXT	ASD4
	PROJECT : ENTERPRISE	REV : 07/06/94	DRAFT				
	COMPANY : DOD		X RECOMMENDED				
	NOTES : 1 2 3 4 5 6 7 8 9 10		PUBLICATION				A2

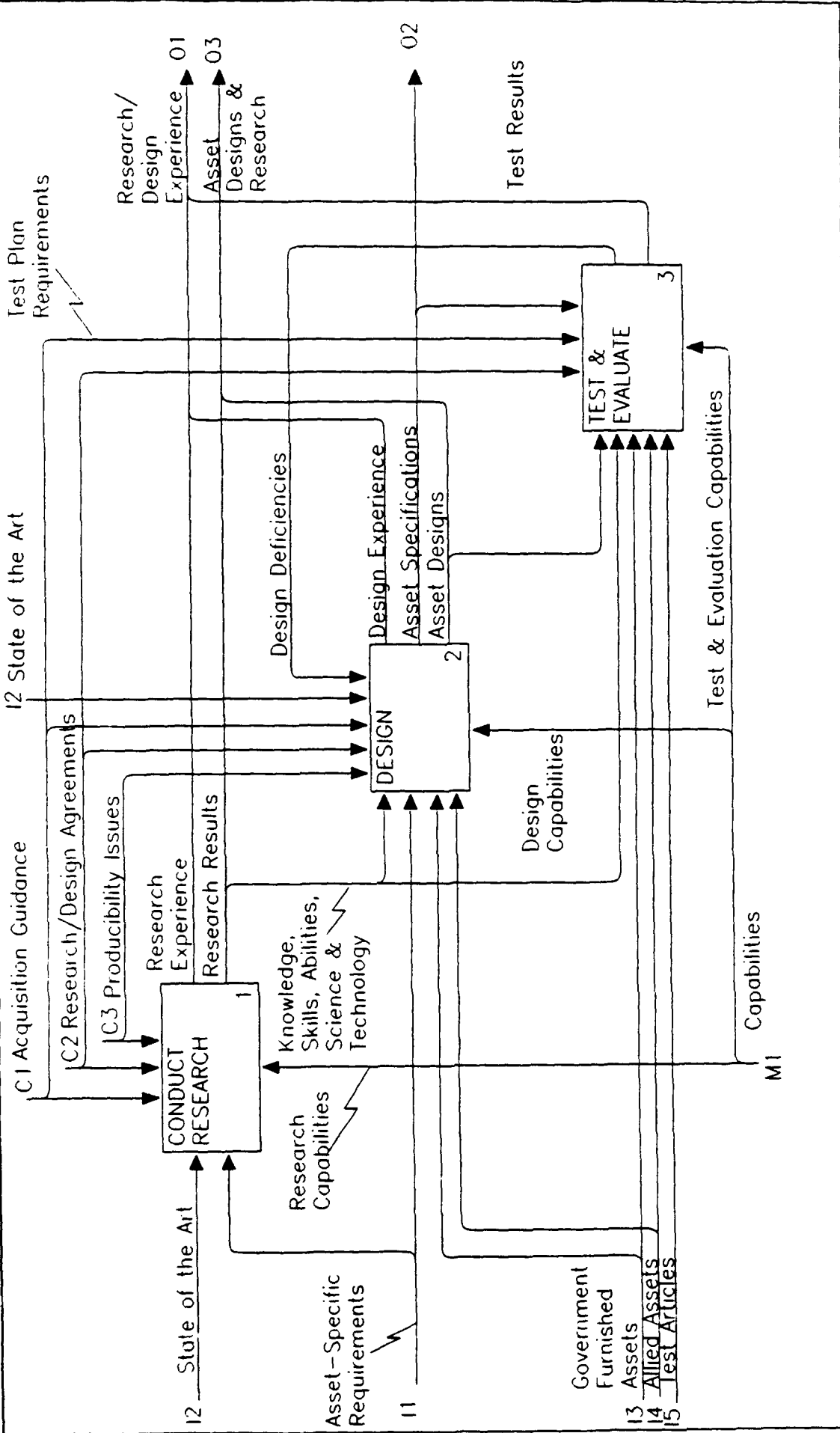

NODE: AS-15/A22	TITLE: RESEARCH & DESIGN (VERSION 2.0)	NUMBER: ASD12
-----------------	--	---------------

## **A23 PRODUCE ASSET**

This activity includes the manufacture of supplies unique to DoD requirements; the construction of facilities; and the accession of people for both civilian and military billets. The acquisition process is complete when DoD receives and signifies acceptance of or rejects potential assets.

This activity represents the actual building/ manufacture, employment through recruiting (accession), and receiving of assets to include all activities typically associated with bringing new personnel, materiel items, real estate/facilities, or services into the inventory (e.g., first destination transportation of materiel items by the vendor from source of acquisition to point of DoD distribution is included). This activity also includes preparing assets for distribution to include any actions necessary to ensure minimum essential asset usefulness at the point of receipt (e.g., providing all military personnel with initial entry training to produce useful officers and enlisted personnel). There are four activities in **Produce Asset**:

**Manufacture Items** represents the detail fabrication, assembly, and inspection of weapons, parts and equipment. The process may be performed by either Government, private industry, or both. The process includes planning, providing required resources, obtaining materials by other than procurement, and production operations.

**Construct Facilities** represents the detailed fabrication, assembly, and inspection of facilities. The process may be performed by either Government, private industry, or both. The process includes planning, providing required resources, obtaining materials by other than procurement, and construction operations.

**Access Personnel** is the function that enlists the skills and services of people to satisfy the DoD mission. It includes the recruiting of military personnel and the employment of government civilian personnel. To obtain a minimally useful individual, all basic training and initial orientation are included in this function.

**Take Delivery** performs an evaluation of real estate, facilities, supplies, services, and people to assure that they comply with requirements. Facilities, supplies, and services may have been manufactured or constructed to Government specification or they may be received directly as commercially available products and services. All people and things entering in the Enterprise must be received before they become Government assets. In addition, procured items must be accepted by procurement in response to notification that they satisfy requirements.

USED AT	AUTHOR : ASD_C31/IM	DATE : 10/26/92	WORKING	READER	DATE	CONTEXT	ASD4
	PROJECT : ENTERPRISE	REV : 07/06/94	DRAFT			<input type="checkbox"/>	
	COMPANY : DOD		X RECOMMENDED			<input type="checkbox"/>	
	NOTES : 1 2 3 4 5 6 7 8 9 10		PUBLICATION				A2

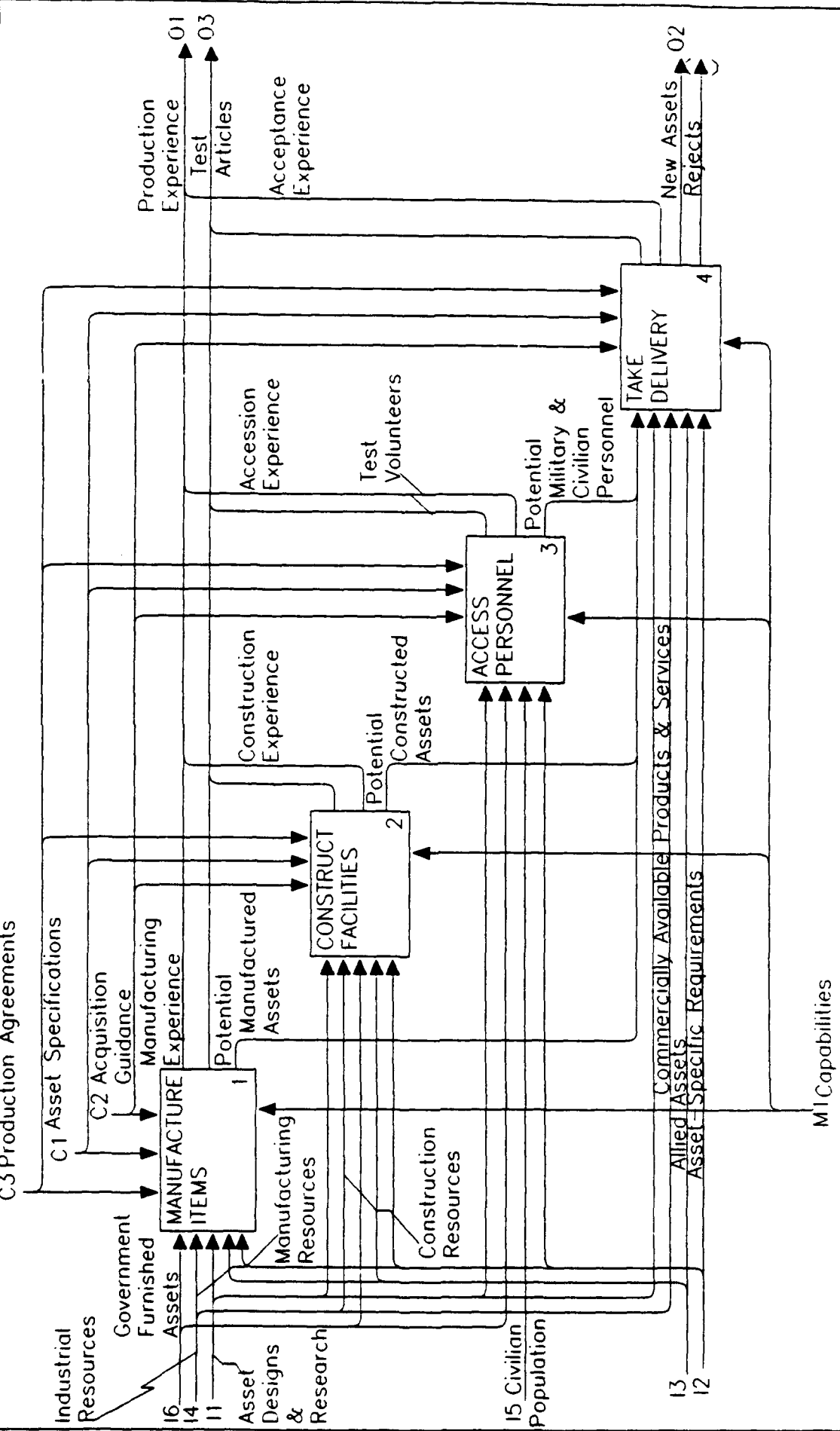

NODE: AS-15/A23	TITLE: PRODUCE ASSET (VERSION 2.0)	NUMBER: ASD13
-----------------	------------------------------------	---------------

### **A3 PROVIDE CAPABILITIES**

This major activity manages the total asset inventory of the DoD (active and inactive military personnel, goods, and services); develops the capabilities and infrastructures needed for support activities; readies force and support units; and provides routine/peacetime and mission support including the mobilization, deployment/re-deployment, and sustainment of forces. Supporting Commands, the Services, and Defense Agencies perform support functions such as supply, maintenance, and transportation, at fixed sites in CONUS and abroad, to achieve peacetime readiness, power projection, and operational objectives. There are four activities in **Provide Capabilities**:

**Manage Assets** controls the allocation of all assets within the Department to organizations, units, or specific inventories. Personnel and materiel assets are assigned to units and organizations in accordance with peacetime and mobilization authorization/distribution plans and the disposition of assets to be maintained, enhanced, transported, or separated.

**Support Assets** sustains people, goods, and services necessary to maintain, enhance, transport, and separate assets. These activities are the national- and local-level actions necessary to conduct and evaluate each of these functions in peacetime and in war.

**Provide Administrative Services** involves administrative support to people and other assets. The services care for the assets, independent of the unique nature of the defense mission. It includes such diverse services as informing and advising people; providing administrative/ management support; supporting and maintaining information operations; providing financial and facility/office services; and providing community services.

**Develop Capabilities** entails the assembly, training, and evaluation of personnel and materiel assets into units and organizations that provide capabilities used to perform all enterprise activities.

USED AT	AUTHOR : ASD_C3I/IM	DATE : 10/07/92	WORKING	READER	CONTEXT	ASD2
	PROJECT : ENTERPRISE	REV : 07/06/94	DRAFT		<input type="checkbox"/>	
	COMPANY : DOD		X RECOMMENDED		<input type="checkbox"/>	
	NOTES : 1 2 3 4 5 6 7 8 9 10		PUBLICATION			A0

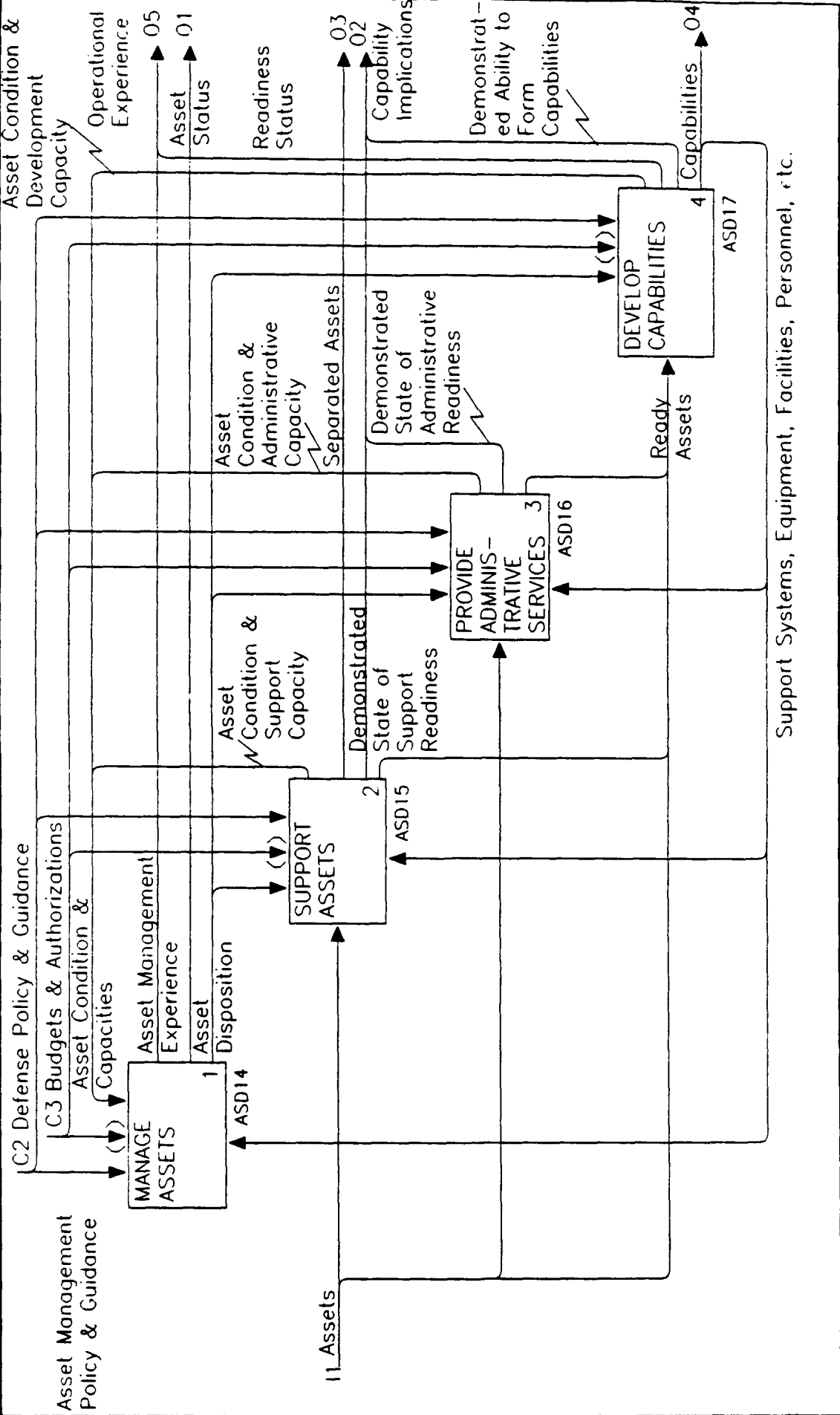

NODE: AS-IS/A3	TITLE: PROVIDE CAPABILITIES (VERSION 2.0)	NUMBER: ASD5
----------------	---	--------------

USED AT	AUTHOR : ASD_C3I/IM	DATE : 11/05/92	WORKING	READER	DATE	CONTEXT	ASD5
	PROJECT : ENTERPRISE	REV : 07/06/94	DRAFT			<input type="checkbox"/>	
	COMPANY : DOD		<input checked="" type="checkbox"/> RECOMMENDED			<input type="checkbox"/>	
	NOTES : 1 2 3 4 5 6 7 8 9 10		PUBLICATION				<input type="checkbox"/>

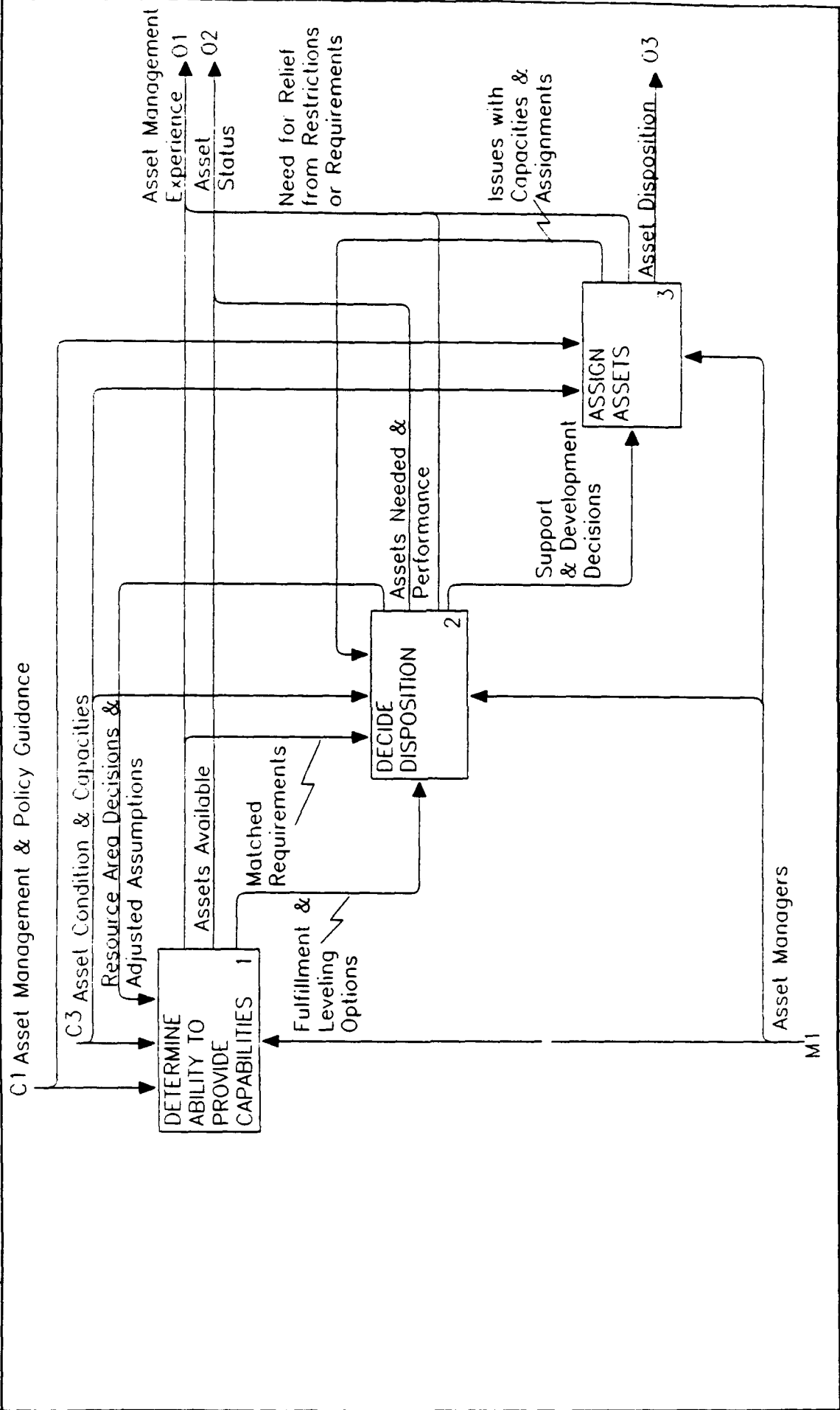

MODE: AS-IS/A31	TITLE: MANAGE ASSETS (VERSION 2.0)	NUMBER: ASD14
-----------------	------------------------------------	---------------

## A32 SUPPORT ASSETS

This activity sustains people, goods, and services necessary to maintain, enhance, transport, and separate assets. These activities involve the national- and local-level actions necessary to conduct and evaluate each of these functions in peacetime and in war. There are four activities in **Support Assets**:

**Maintain** includes the maintenance and repair of materiel items and systems (to include automation systems) through depot-level maintenance; the healing of sick/wounded personnel and caring for their dependents through dispensaries and medical clinics/hospitals; and the maintenance and repair of facilities and real estate.

**Enhance** includes the post-accession individual training for skill progression and career advancement at the Service branch schools and colleges/universities. It includes the planned and programmed refurbishment and modification of materiel items that result in enhanced capabilities and changes to facilities that also improve their utility. As a result of this activity, personnel gain skill qualifiers and existing materiel items change functions/capabilities.

**Transport** includes all actions necessary to deploy assets and units from one place to another. Movement of forces and assets in the AOR is addressed in **Employ Forces**. Typically, the movement of assets involves inter-theater transportation/lift (ground, sea, or air). **Transport** also entails all actions necessary to recover and account for all forces and assets once an operation/exercise has been concluded, to include the re-deployment or retrograde of materiel and personnel from missions and areas of operation. This activity also involves the recurring peacetime movement of individual assets for unit replacement, sustainment, or separation, including moving service members, their families, and household goods.

**Separate** includes all actions called for by Department or other government regulations to support separation of assets from US government control and accountability. This includes routine peacetime or demobilization actions related to active and inactive inventories of personnel, materiel, facilities, and real estate (e.g., foreign military sales, demilitarization of munitions, environmental clean-up, and one-time benefit assignments associated with death and disability).

USED AT	AUTHOR : ASD_C31/IM	DATE : 10/29/92	WORKING	READER	DATE	CONTEXT ASD5
	PROJECT : ENTERPRISE	REV : 07/06/94	DRAFT			
	COMPANY : DOD		X RECOMMENDED			
	NOTES : 1 2 3 4 5 6 7 8 9 10		PUBLICATION			A3

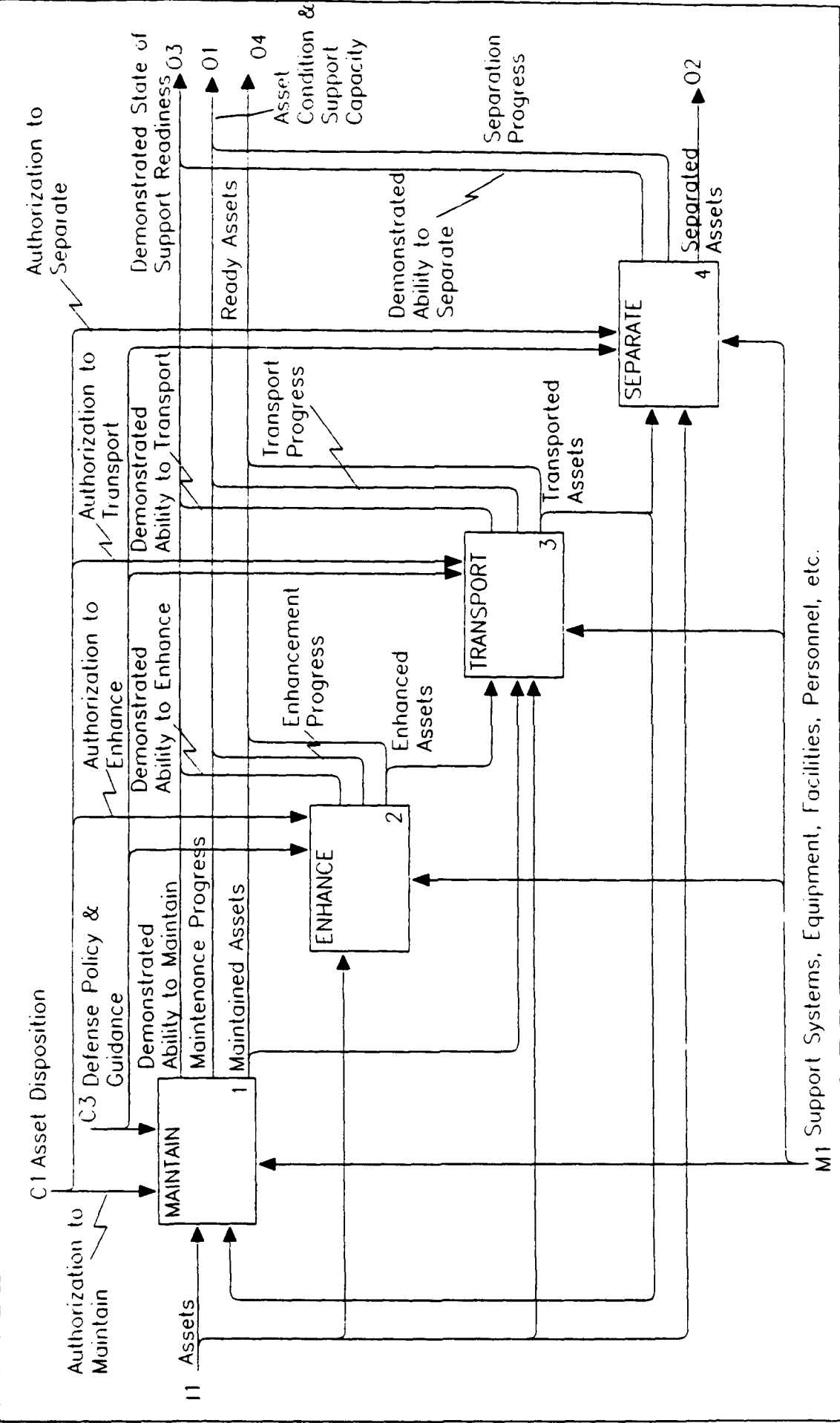

MODE: AS-IS/A32	TITLE: SUPPORT ASSETS (VERSION 2.0)	NUMBER: ASD11
-----------------	-------------------------------------	---------------

### **A33 PROVIDE ADMINISTRATIVE SERVICES**

This activity provides administrative support to people and other assets. The focus of the services is to care for the assets, independent of the particular nature of the defense activities in which they are involved. It includes such diverse activities as informing and advising people (both internal and external DoD); providing administrative/management support; supporting and maintaining information operations; providing financial and facility/office services; and providing community services. There are five activities in **Provide Administrative Services**:

**Inform & Advise** provides explanations and expert opinions to people on such matters as health benefits, legal rights, personnel policy, and job openings. The focus of the activity is on the personal concerns of people, as opposed to their needs associated with their defense responsibilities.

**Provide Information Operational Services** carries out the day-to-day generic operations required to deliver information-processing support to users. Such services include installing computers and related equipment, setting up LANs, replacing equipment with newer versions, loading application software packages, and packing equipment for shipment.

**Provide Financial Services** examines financial records (such as time reports, travel expense reports, and financially significant events occurring throughout the Defense enterprise); identifies discrepancies, errors, and misrepresentations; associates findings with corresponding records; and creates financial transactions appropriate to the functions of the records (such as paychecks and travel expense reimbursements, corrections to previous tax withholdings, W-2 statements).

**Provide Facility Services** ensures that workplaces continue to operate in an orderly manner through activities such as processing mail, replenishing supplies of consumable assets, holding social functions, providing clerical services, and provide physical security.

**Provide Community Services** ensures that qualified military and civilian personnel and families have access to such services and facilities as commissaries, post or base exchanges, schools for military dependents, housing, social and athletic activities, and religious institutions.

USED AT	AUTHOR : ASD C3/IM	DATE: 11/30/93	WORKING	READER	DATE	CONTEXT	ASD5
	PROJECT : ENTERPRISE	REV: 07/06/94	DRAFT				
	COMPANY : DOD		X RECOMMENDED				
	NOTES : 1 2 3 4 5 6 7 8 9 10		PUBLICATION				A3

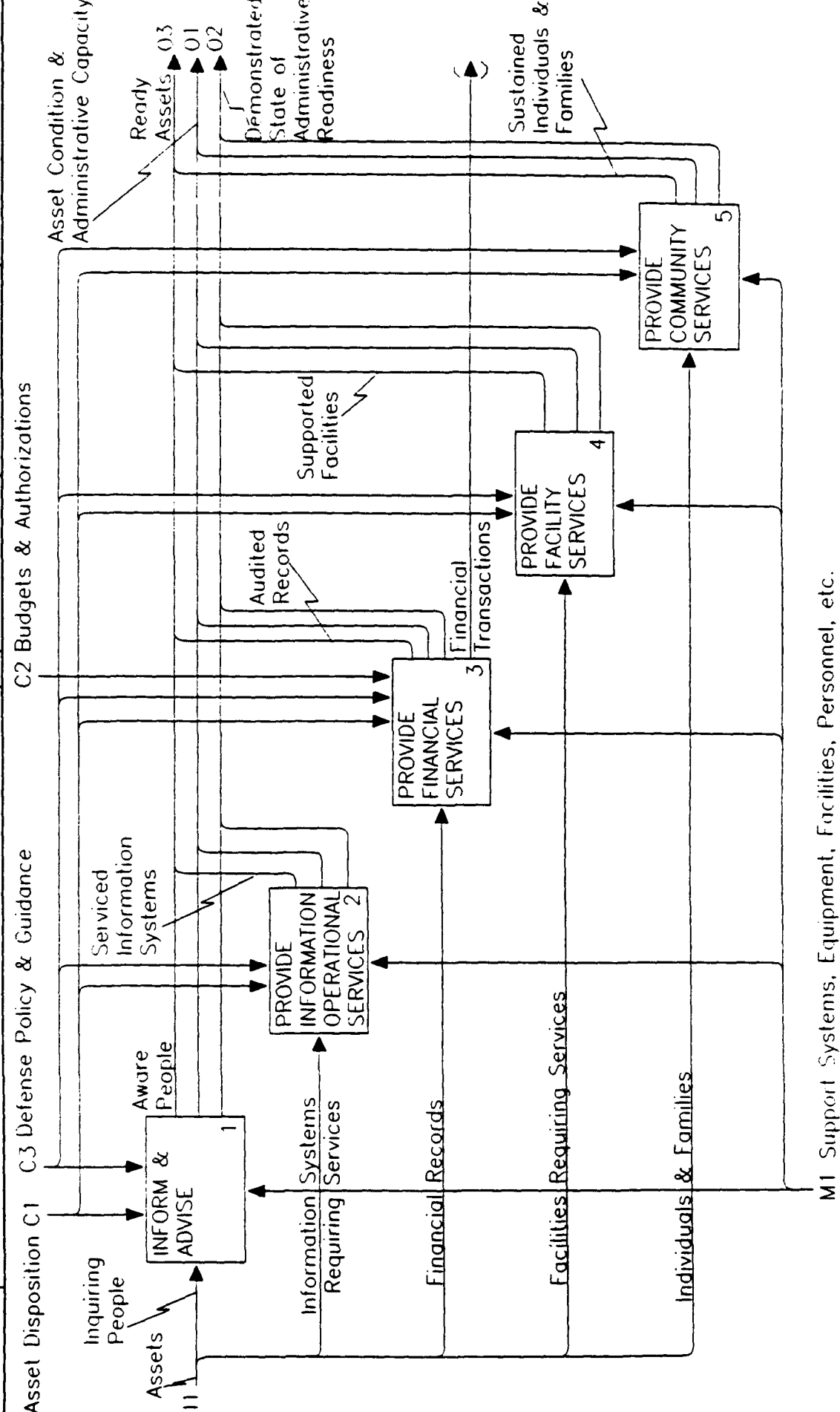

Asset Disposition C1 C3 Defense Policy & Guidance C2 Budgets & Authorizations M1 Support Systems, Equipment, Facilities, Personnel, etc.

NOTE: AS-IS/A33 TITLE: PROVIDE ADMINISTRATIVE SERVICES (VERSION 2 0) NUMBER: ASD16

## **A34 DEVELOP CAPABILITIES**

This activity entails the assembly, training, and evaluation of personnel and materiel assets into units and organizations that provide capabilities used to deter and wage war, provide support, and administer the Department. There are three activities in **Develop Capabilities**:

**Integrate** forms organizational elements from individual military and civilian personnel and materiel items that have been assigned or distributed to units. It integrates personnel and equipment within the command structure of a unit or organization and imbuing those individuals with the spirit and cohesion necessary to perform a specified organizational mission.

**Train Units & Organizations** involves conducting the annual training program to maintain unit and organizational proficiency. The training program is focused on those tasks, conditions, and standards used to define and evaluate organizational/unit skills essential to performing assigned missions or functions.

**Assess Readiness** performs the evaluation of unit/organizational asset status and proficiency to accomplish assigned missions. It usually includes an objective measurement of asset status, a subjective assessment by commanders of the unit's ability to perform the mission, and the reporting, tracking, and monitoring of that status through the Joint Reporting Structure (JRS) and the Service support systems.

USED AT	AUTHOR : ASD_C3I/IM	DATE: 11/05/92	WORKING	READER	DATE	OHTEXT	ASD5
	PROJECT : ENTERPRISE	REV : 07/06/94	DRAFT			<input type="checkbox"/>	
	COMPANY : DOD		X RECOMMENDED			<input type="checkbox"/>	
	NOTES : 1 2 3 4 5 6 7 8 9 10		PUBLICATION				A3

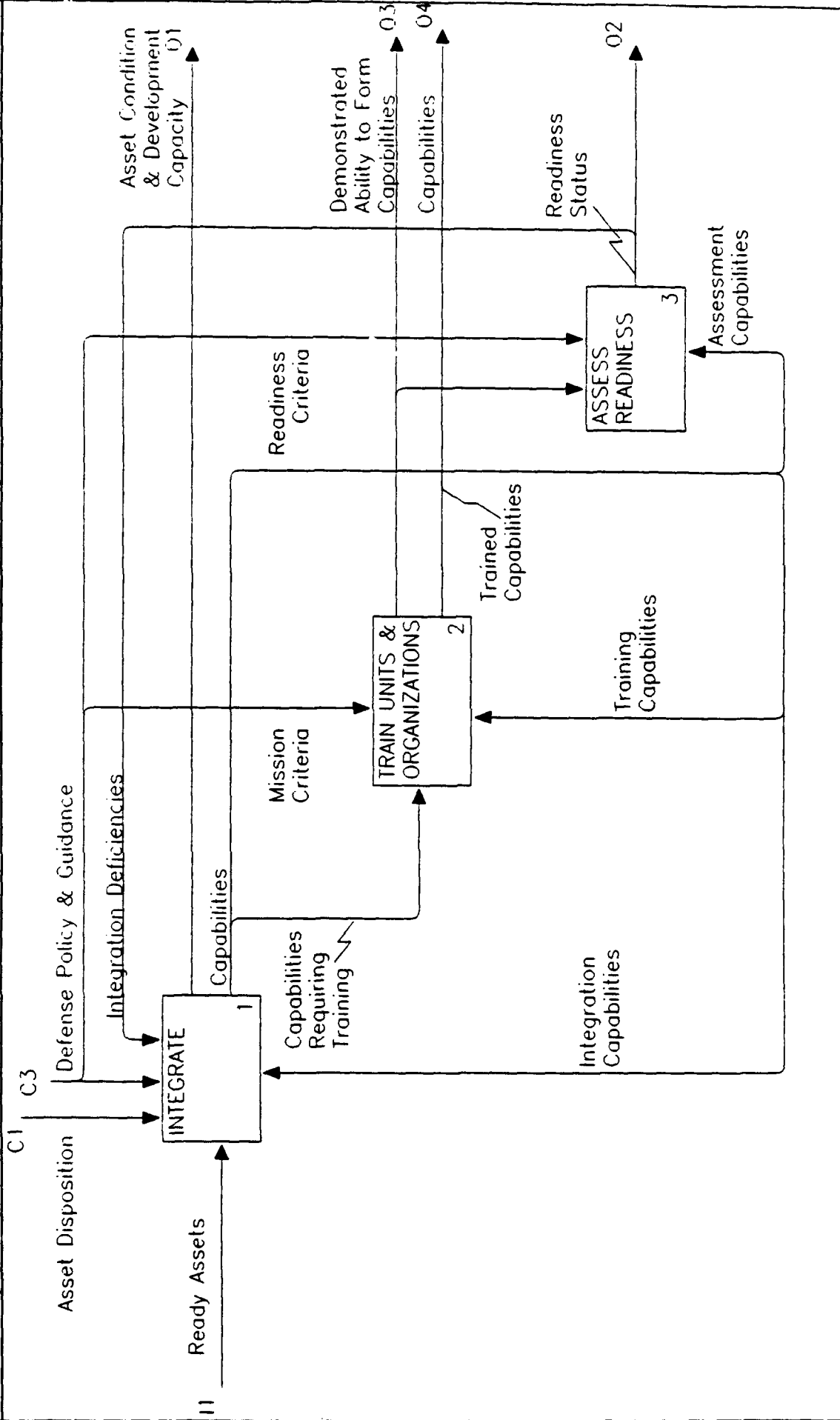

NODE: AS-IS/A34	TITLE: DEVELOP CAPABILITIES (VERSION 2.0)	NUMBER: ASD17
-----------------	---	---------------

## A4

### EMPLOY FORCES

This major activity of the enterprise encompasses all the actions associated with executing National Command Authority (NCA) decisions and orders within the context of the National Military Strategy. Main elements of the strategy include: forward military presence, crisis response, and strategic deterrence and defense.

All plans and orders are developed and issued in the first activity of the enterprise, **Establish Direction**. **Employ Forces** operations are conducted to execute the assigned missions of the Department when called upon by the President in times of peace, crisis, warfighting, war termination, and reconstitution after an operation. Exercises are usually undertaken at the direction of an authority below the NCA. There are four activities in **Employ Forces**:

**Constitute Forces** develops and prepares the command structures and the forces in the Area of Responsibility (AOR) that will respond to the NCA direction to conduct an operation or to perform a joint exercise.

**Provide Operational Intelligence** identifies specific requirements for managing operational intelligence; assesses the operating environment; assesses the operating environment; collects raw intelligence from a variety of sources; fuses and analyzes the data; and distributes finished intelligence products to Commanders, when, where, and in the form needed to support operations in the field.

**Conduct Operations** conducts major training exercises and operational missions. Exercises take place in a service/joint/combined employment force structure environment. This activity involves the evaluation of force readiness or organizational proficiency through tests and exercises to include field/fleet, command post, and deployment exercises. It includes Conventional, Nuclear, Space, Special and Inter/Intra Government Operations.

**Sustain Operations** sustains forces in the AOR. It maintains materiel, sustains people, provides supplies, and moves assets throughout the AOR before operations commence, during execution, and after operations terminate. The activities are integrated into the combatant Commander's scheme of maneuver, fires, protection, and strike, so they provide the right support at the right time and place to achieve mission objectives. This activity is related to **Support Assets** in A3. While similar, these two activities are usually performed in different environments, and under different command/management. Therefore, they are perceived to be distinct and different activities within the DoD community. DoD's objective is to integrate these activities seamlessly.

USED AT	AUTHOR : ASD_C31/IM	DATE : 10/07/92	WORKING	READER	DATE	CONTEXT	ASD2
	PROJECT : ENTERPRISE	REV : 07/06/94	DRAFT			<input type="checkbox"/>	
	COMPANY : DOD		X RECOMMENDED			<input type="checkbox"/>	
	NOTES : 1 2 3 4 5 6 7 8 9 10		PUBLICATION			<input type="checkbox"/>	
							AO

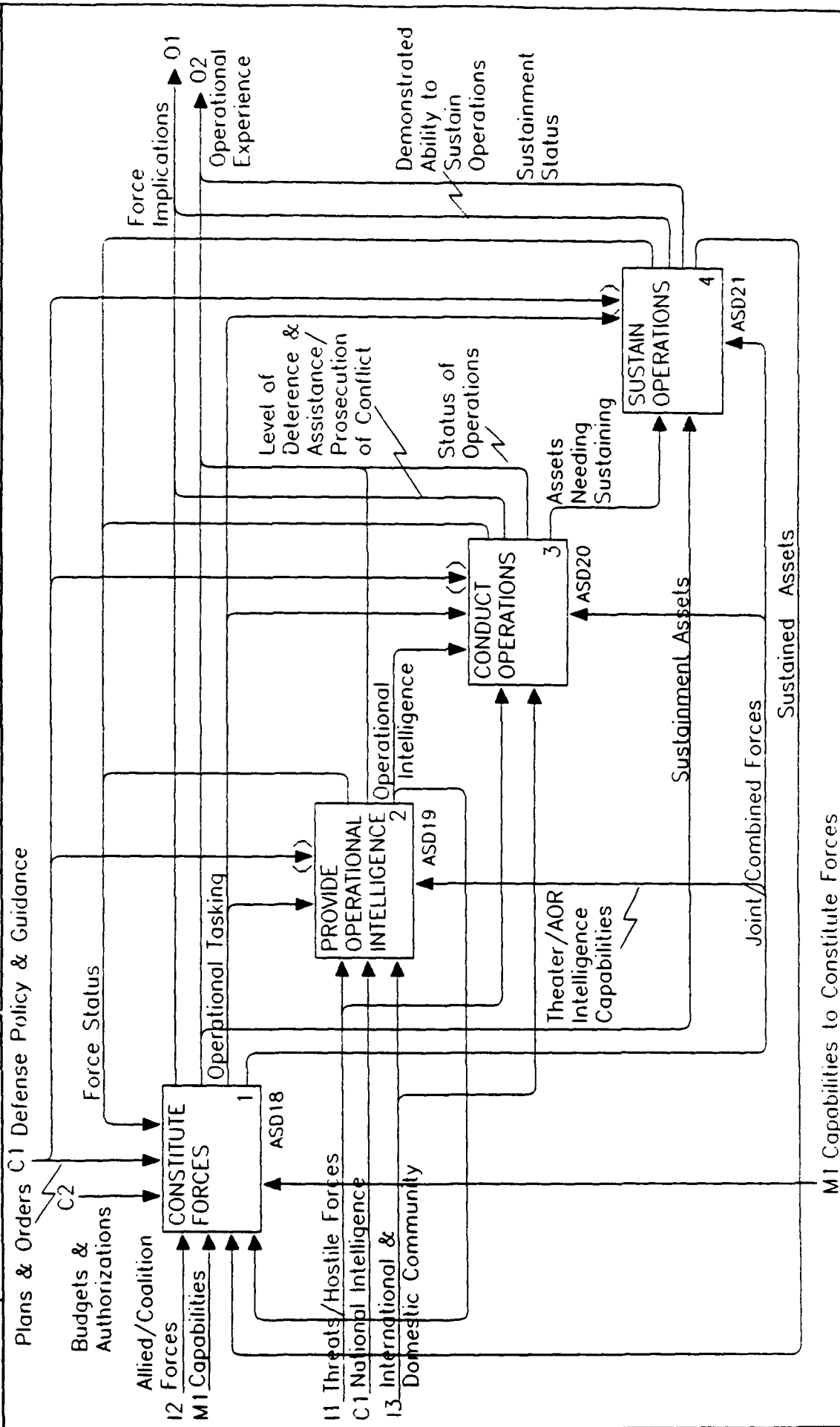

MODE: AS-IS/A4	TITLE: EMPLOY FORCES (VERSION 2.0)	NUMBER: ASD6
----------------	------------------------------------	--------------

## **A41 CONSTITUTE FORCES**

This activity develops and prepares the command structure and the forces in the Area of Responsibility (AOR) that will respond to the National Command Authority (NCA) direction to conduct an operation to perform a joint exercise. There are three activities in **Constitute Forces**:

**Organize Command** organizes a command or task force and assigns units based on assigned tasks. In some cases, units are already assigned, and this activity changes command assignment of organizations allocated to the operational command structure of a supported Commander in Chief (CINC), Joint Task Force commander, or other combatant commander within an assigned AOR.

**Assess Plans & Orders** assesses plans, orders, Rules of Engagement (ROE) and the status of plan execution. Of particular importance for the Commander is the arrival and integration of assigned units into forces in the AOR as prescribed by the plan and as they are being deployed through the **Transport** activity described earlier.

**Integrate Forces** integrates units from multiple services into a joint force, and integrates units from multiple countries into a combined force. The combined force may include US, allied and coalition forces.

USED AT	AUTHOR : ASD_C3I/IM	DATE: 11/05/92	WORKING	READER	DATE	CONTEXT	ASD6
	PROJECT : ENTERPRISE	REV. : 07/06/94	DRAFT			<input type="checkbox"/>	
	COMPANY: DOD		X RECOMMENDED			<input type="checkbox"/>	
	NOTES : 1 2 3 4 5 6 7 8 9 10		PUBLICATION			<input type="checkbox"/>	A4

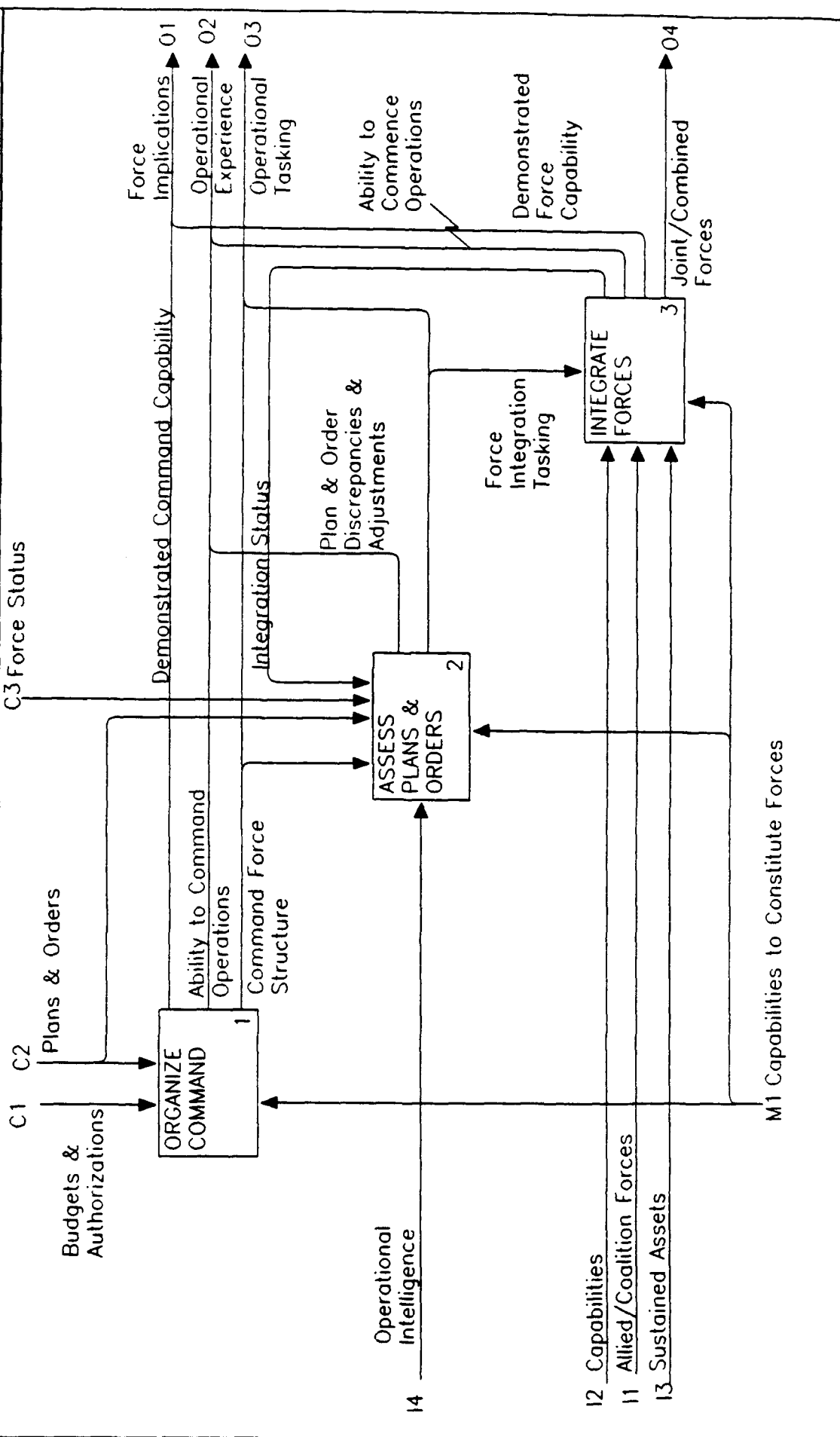

NODE: AS-IS/A41	TITLE: CONSTITUTE FORCES (VERSION 2.0)	NUMBER: ASD18
-----------------	--	---------------

## A42 PROVIDE OPERATIONAL INTELLIGENCE

This activity identifies specific requirements for managing operational intelligence; assesses the operating environment; collects raw intelligence from a variety of sources; fuses and analyzes the data; and distributes finished intelligence products to Commanders, when, where, and in the form needed to support operations in the field. There are three activities in **Provide Operational Intelligence**:

**Collect Operational Intelligence** responds to specific requirements for intelligence information which are identified prior to and during operations. These include the enemy order-of-battle, intentions, facilities and installations, civilian populations, operational environments, weather, status of friendly forces, logistics, command and control, and damage assessments. Intelligence capabilities at the national and theater levels are focused on the specific needs of the theater commanders. Various collection assets are employed at the national and theater levels to gather human, communications, signal, and imagery data (raw intelligence).

**Fuse/Analyze** fuses and analyzes intelligence data to produce finished intelligence products useful to Commanders. Different sources such as *national intelligence* are compared to evaluate estimates of the emerging situation until a level of certainty is reached.

**Provide Products to Commanders** provides finished intelligence products, including assessments and data necessary for conducting operations (e.g., targeting information) to Commanders in a timely and secure manner. Different media are used to present the information to maximize its utility.

USED AT	AUTHOR : ASD_C3I/IM	DATE : 11/05/92	WORKING	READER	CONTEXT	ASD6
	PROJECT : ENTERPRISE	REV : 07/06/94	DRAFT		<input type="checkbox"/>	
	COMPANY : DOD		X RECOMMENDED		<input type="checkbox"/>	
	NOTES : 1 2 3 4 5 6 7 8 9 10		PUBLICATION		<input type="checkbox"/>	A4

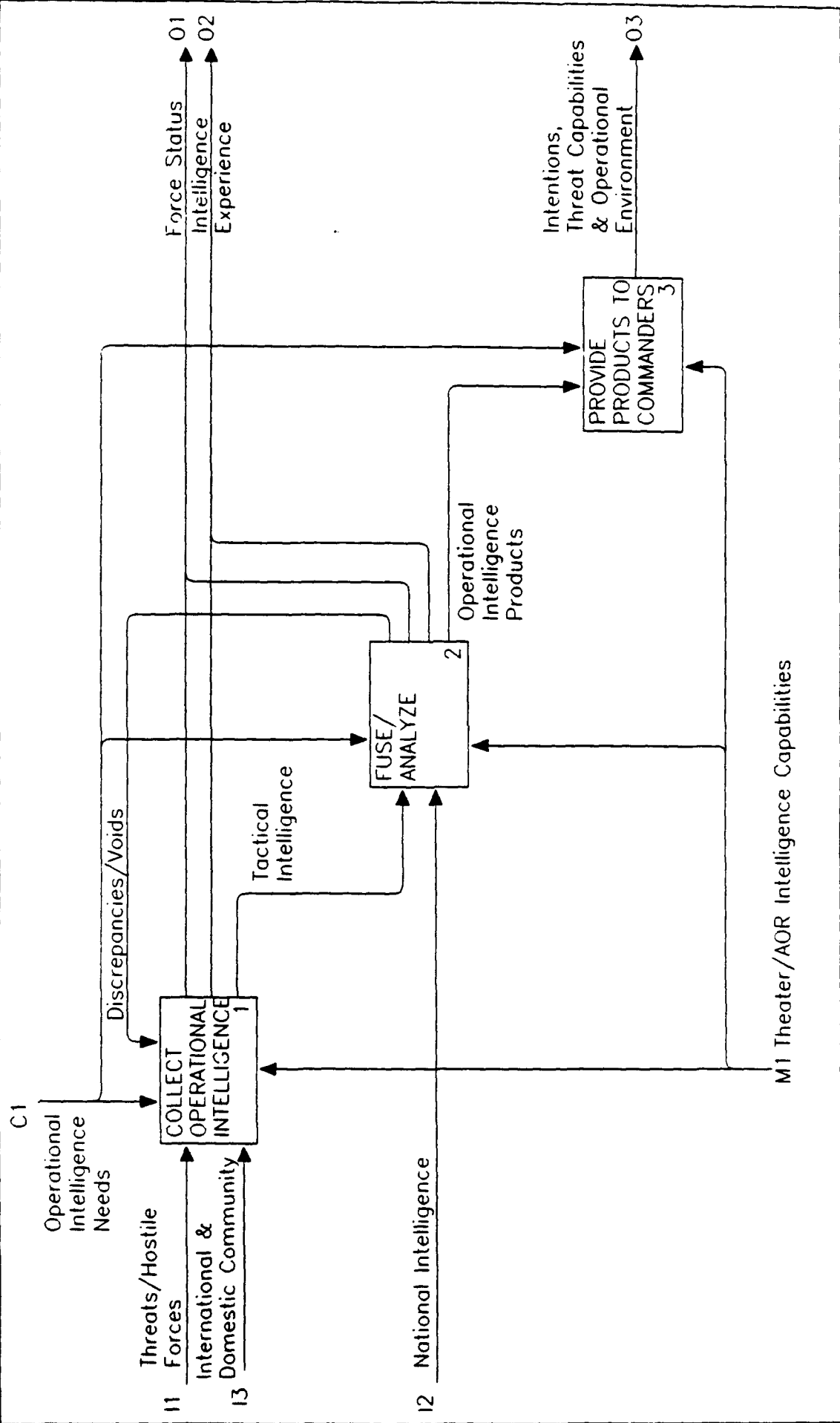

NODE: AS-IS/A42	TITLE: PROVIDE OPERATIONAL INTELLIGENCE (VERSION 2.0)	NUMBER: ASD19
-----------------	---	---------------

## **A43 CONDUCT OPERATIONS**

This activity conducts major training exercises and operational missions. Exercises take place in a service/joint/combined employment force structure environment. This activity evaluates force readiness or organizational proficiency through tests and exercises to include field/fleet, command post, and deployment exercises.

Operational missions are initiated by the NCA and involve executing the approved concept of operation and scheme of maneuver and fires (if applicable) embedded in the OPLAN, to include all the nested concepts developed and executed by subordinate commanders to achieve the mission objectives of the plan. There are attendant departmental/agency consequences in terms of increased workloads and other mobilization effects that are also captured in this activity.

Activities in this area are sometimes initiated at the direction of the President in concert with the Domestic Policy Council, and sometimes with the Governors of the States and Territories. This activity can involve the use of federal and National Guard forces to provide assistance at times of national disaster, to support federal, state and local infrastructure initiatives, and to restore civil order. There are five activities in **Conduct Operations**:

**Conduct Conventional Operations** includes operations conducted by general purpose forces which do not include the use of nuclear weapons. These operations include peacekeeping, and major and lesser regional conflicts. Conventional operations are performed by air, land, and maritime forces to gain, maintain, and exploit control of the operational environment in forward and rear areas of operations. They include joint air defense/air space management operations, and integrated fire support operations.

**Conduct Nuclear Operations** uses Nonstrategic Nuclear Forces (NSNF) and Strategic Nuclear Forces (SNF) to deter conflict by posturing forces to conduct nuclear operations in response to a threat of an attack against vital US interests and to employ the NSNF and NSF as directed by the NCA. NSNF provide an escalatory or retaliatory response below the level of strategic nuclear forces and serve as a deterrent to weapons of mass destruction. Strategic nuclear operations protect against strategic nuclear attack on the US, and plans, safeguards, executes, recovers/reconstitutes, and terminate nuclear offensive operations.

**Conduct Space Operations** includes operations that provide freedom of action in space for friendly forces while, when directed, denying it to any enemy, and encompasses the broad aspects of protection of US and allied space systems and negations of enemy space systems.

USED AT	AUTHOR : ASD_C3I/IM	DATE : 11/05/92	WORKING	READER	DATE	CONTEXT	ASD6
	PROJECT : ENTERPRISE	REV : 07/06/94	DRAFT				
	COMPANY : DOD		X RECOMMENDED				
	NOTES : 1 2 3 4 5 6 7 8 9 10		PUBLICATION			A4	

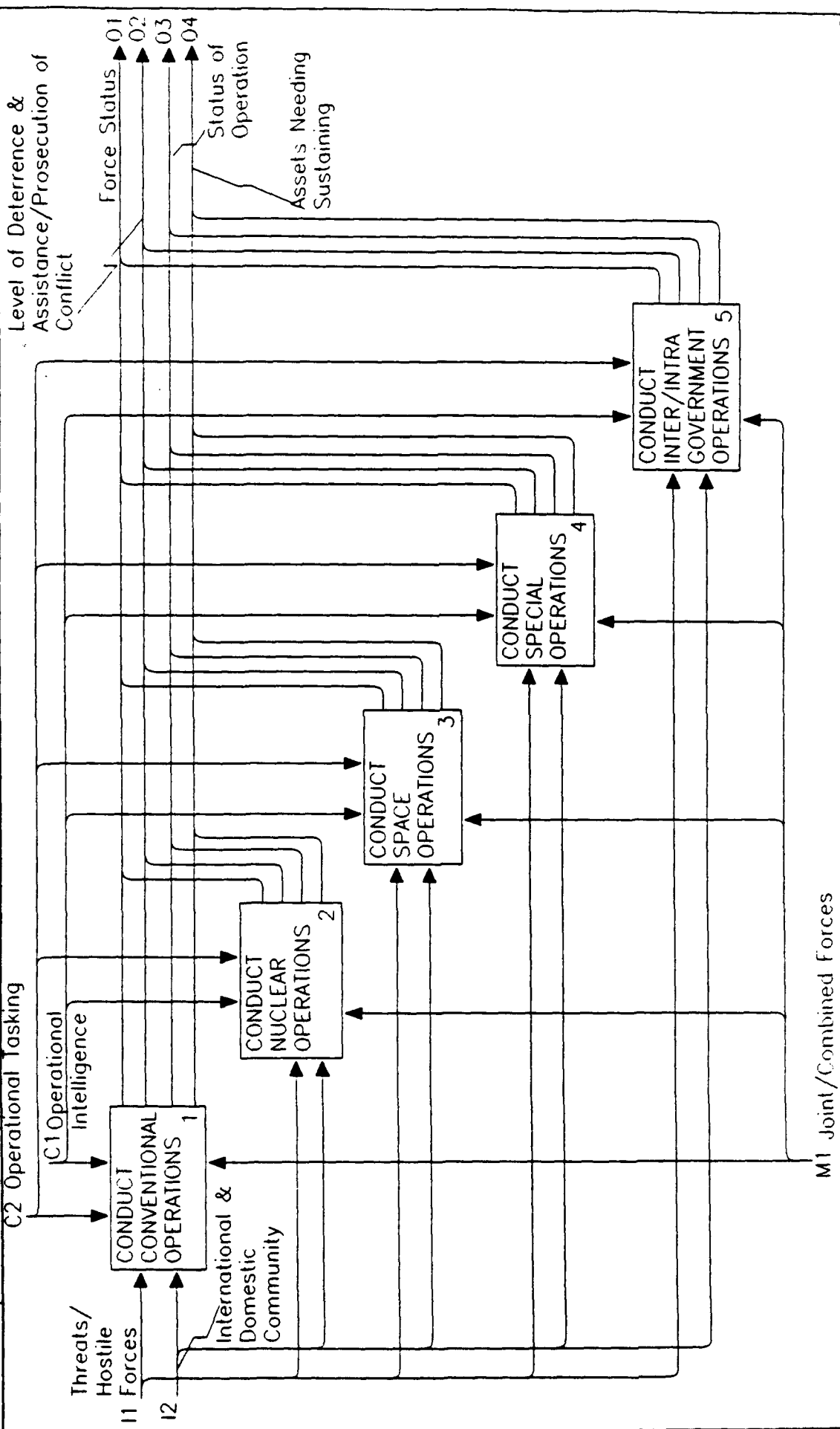

NODE: AS-15/A43	TITLE: CONDUCT OPERATIONS (VERSION 2.0)	NUMBER: ASD20
-----------------	---	---------------

**Conduct Special Operations** includes operations conducted by specially trained, equipped, and organized DoD forces against strategic or tactical targets in pursuit of national military, political, economic, or psychological objectives. These operations may be conducted during periods of peace or hostilities. They may support conventional operations, or they may be prosecuted independently when the use of conventional forces is either inappropriate or infeasible.

**Conduct Inter/Intra Government Operations** includes operations conducted in coordination with other nations and US government agencies, states and localities, for humanitarian assistance, disaster relief, support to civil authorities and other operations which are not a response to a direct military threat.

USED AT	AUTHOR : ASD_C3I/IM	DATE : 11/05/92	WORKING	READER	DATE	CONTEXT	ASD6
	PROJECT : ENTERPRISE	REV : 07/06/94	DRAFT			<input type="checkbox"/>	
	COMPANY : DOD		X RECOMMENDED			<input checked="" type="checkbox"/>	
	NOTES : 1 2 3 4 5 6 7 8 9 10		PUBLICATION			<input type="checkbox"/>	A4

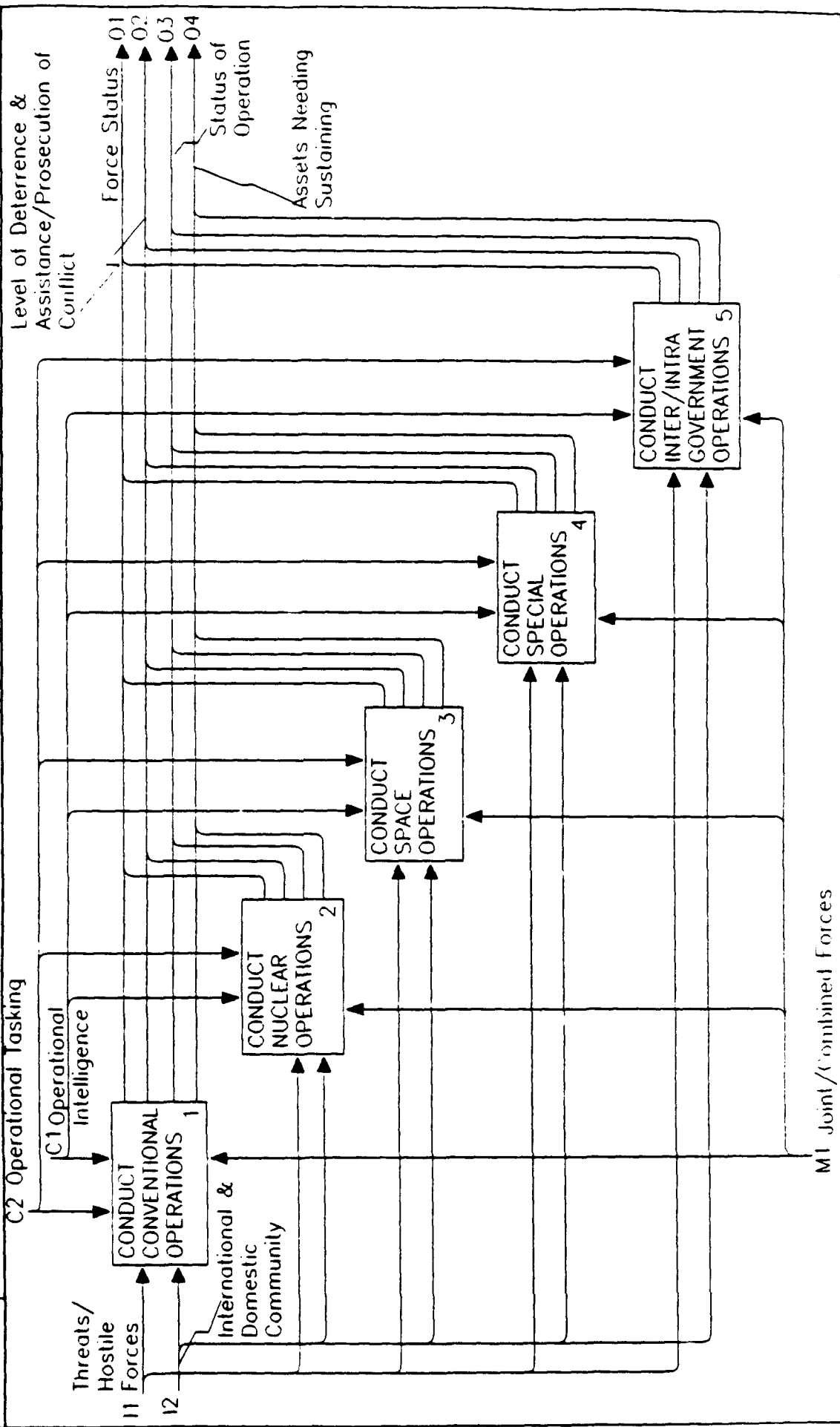

FIGURE : A5/IS/A43	TITLE : CONDUCT OPERATIONS (VERSION 2.0)	NUMBER : A5-1120
--------------------	--	------------------

## **A44 SUSTAIN OPERATIONS**

This activity sustains forces in the AOR. It maintains materiel, sustains people, provides supplies, and moves assets throughout the AOR before operations commence, during execution, and after operations terminate (e.g., for re-deployment out of the AOR). The activities are integrated into the combatant Commander's scheme of maneuver, fires, protection, and strike, so they provide the right support to the forces at the right time and place to achieve mission objectives. The functions described in **Sustain Operations** are similar to sustaining base functions described in **Provide Capabilities**. However, those sustaining operations are generally conducted in the Continental US (CONUS) as part of the routine operation of the department and preparation to meet contingencies (e.g., mobilization). The activities described here occur on the "battlefield," in extreme environments and under hazardous conditions. They often involve different mechanisms (e.g., systems) and controls, and are usually performed as an integral part of a military operation (see **Conduct Operations**). There are four activities in **Sustain Operations**:

**Maintain Materiel** keeps equipment, weapons, facilities, and other materiel assets in repair in the AOR so they can be employed in operations.

**Sustain People** houses, feeds, clothes, provides medical care for, pays, and provides other support needed by military personnel and civilians in the AOR.

Sustainment activities such as military and civilian pay remain in A3 because the process is always the same.

**Resupply** provides items for consumption and replacement, such as food, fuel, ammunition, and spares.

**Move** re-positions assets from one geographical location to another within the AOR, in accordance with specified timing and other movement requirements.

USED AT	AUTHOR : ASD_C31/IM	DATE : 11/22/93	WORKING	READER	DATE	CONTEXT	ASD6
	PROJECT : ENTERPRISE	REV : 07/06/94	DRAFT				
	COMPANY : DOD		X RECOMMENDED				
	NOTES : 1 2 3 4 5 6 7 8 9 10		PUBLICATION				A4

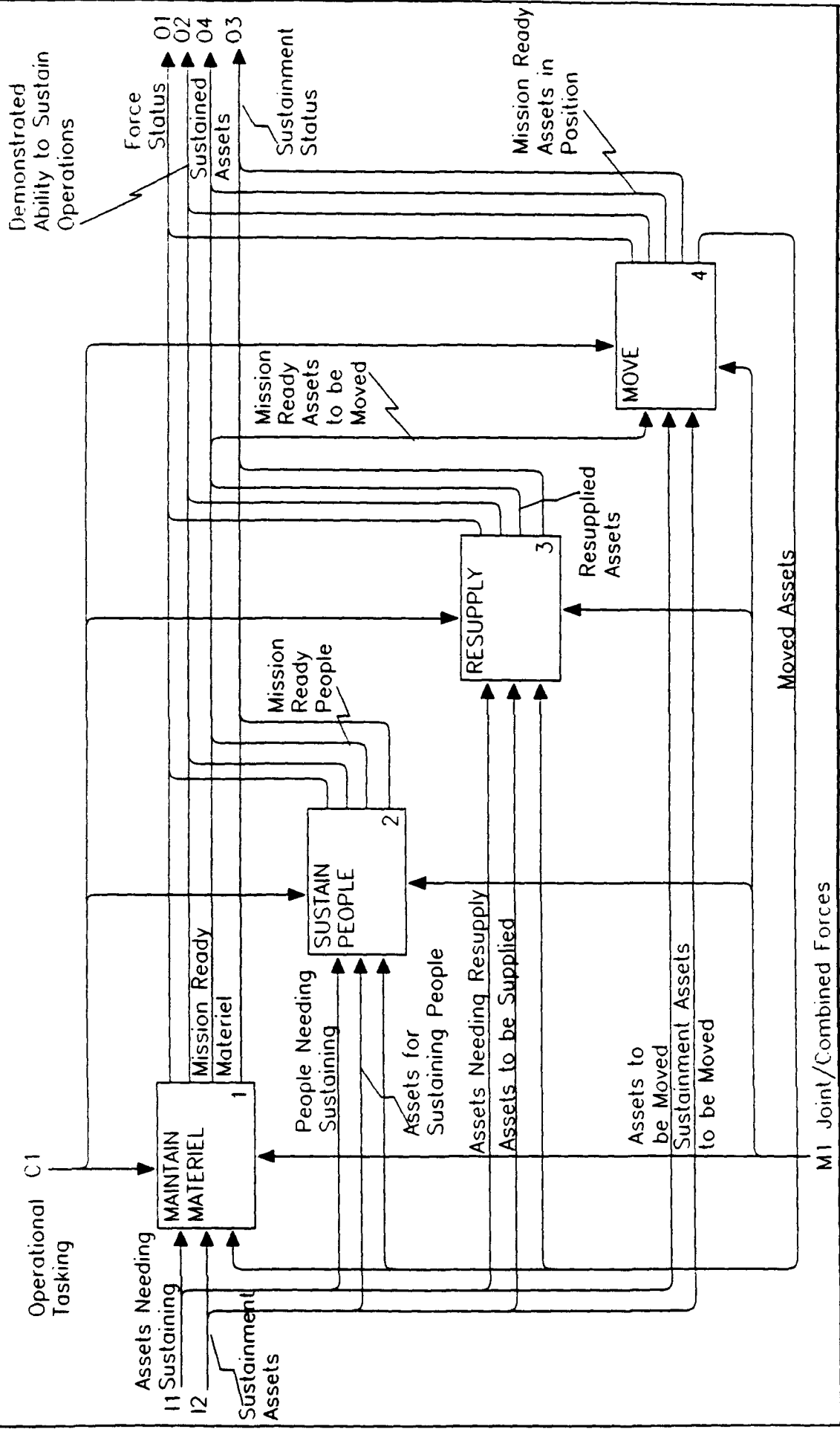

NODE: AS-IS/A44	TITLE: SUSTAIN OPERATIONS (VERSION 2.0)	NUMBER: ASD21
-----------------	---	---------------

**APPENDIX B**  
**ACTIVITY MODEL GLOSSARY**

**APPENDIX B  
ACTIVITY MODEL GLOSSARY**

**ABILITY TO COMMAND OPERATIONS (A41)**

The enterprise's ability to exert command and control on the conduct of operations.

**ABILITY TO COMMENCE OPERATIONS (A41)**

The enterprise's ability to initiate a Defense mission.

**ACCEPTANCE EXPERIENCE (A23)**

Knowledge gained in taking delivery of potential assets. It provides lessons learned about the process and may designate assets for uses other than the original intended use.

**ACCESSION EXPERIENCE (A23)**

Knowledge gained in the accession of people, including lessons learned about the process.

**ACQUISITION GUIDANCE (A2, A21, A22, A23)**

Directives, regulations, policies, procedures, and asset requirements for the acquisition of new or replacement assets. It includes the assignment of lead and supporting Service, Agency, Command, and unit responsibilities and it establishes programmatic milestones and funding authority. It establishes the rules for each type of acquisition (small purchase, managed program, etc.). It also provides approvals for procurement strategies and plans including deviations and waivers of restrictions.

**ACQUISITION IMPLICATIONS (A0, A2, A21)**

Information available, outside the enterprise, of intent or undertaking to acquire specific assets. The intent to acquire new offensive technology has strategic implications to those who are deterred by DoD's demonstration of resolve to possess that technology as well as to those Allies who feel reassured by the possession of that technology.

**APPENDIX B**  
**ACTIVITY MODEL GLOSSARY**

---

**ACQUISITION MANAGEMENT & TECHNICAL CAPABILITIES (A21)**

This includes Procurement Contracting Officers, Administrative Contracting Officers, Program Managers, Heads of Contracting Authorities, and their staffs as well as supporting functional capabilities such as engineering, test, logistics, and quality.

**AGGREGATED CAPABILITIES & ISSUES (A14)**

Collective resources and assets that have the ability to perform a set of functions. It includes proposed capabilities that share significant commonality of functions, potential approaches to combining such capabilities into a single capability, and issues involved in such combining.

**ALLIED ASSETS (A-0, A0, A2, A22, A23)**

Assets of countries, designated by treaty as aligned with the US, which are available for use by the enterprise.

**ALLIED/COALITION FORCES (A-0, A0, A4, A41)**

Military forces designated by treaty (Allied), or joined in a temporary alliance (Coalition) that are committed to a common course of action, usually under a unified chain of command.

**ASSESSMENT CAPABILITIES (A34)**

The capabilities applied by the enterprise to evaluate the degree to which other capabilities are prepared to accomplish their anticipated or assigned missions. Such evaluation usually involves an objective measurement of assets' abilities to perform as members of a capability and a subjective assessment of the capability's overall ability to perform adequately.

**APPENDIX B  
ACTIVITY MODEL GLOSSARY**

---

**ASSET CONDITION & ADMINISTRATIVE CAPACITY (A3, A33)**

The state of fitness or readiness of assets to achieve the designed/desired levels of performance, along with the capacity for administrative support systems, equipment, facilities, personnel, etc., to provide administrative services. This includes descriptions of findings associated with audited records.

**ASSET CONDITION & CAPACITIES (A3, A31)**

The state of fitness or readiness of assets to achieve the designed/desired levels of performance, along with the capacity to support assets, provide administrative services, and develop capabilities.

**ASSET CONDITION & DEVELOPMENT CAPACITY (A3, A34)**

The state of fitness or readiness of assets to achieve the designed/desired levels of performance, along with the capacity for administrative support systems, equipment, facilities, personnel, etc. to develop capabilities.

**ASSET CONDITION & SUPPORT CAPACITY (A3, A32)**

The state of fitness or readiness of assets to achieve the designed/desired levels of performance, along with the capacity for administrative support systems, equipment, facilities, personnel, etc. to support assets.

**ASSET DESIGNS (A22)**

The translation of functional, technical, and physical specifications of an asset into drawings, blueprints, models, descriptions, or other media that lead to production of the asset.

**ASSET DESIGNS & RESEARCH (A2, A22, A23)**

Advances in scientific knowledge or asset designs that guide the production activities or are converted directly into assets.

---

**APPENDIX B  
ACTIVITY MODEL GLOSSARY**

---

**ASSET DISPOSITION (A3, A31, A32, A33, A34)**

A determination of how an asset will be used and whether any additional processing is required prior to its assignment to an individual, unit or organization. Such decisions are based on authorization, need, relative priorities, and capabilities and capacities both for supporting the asset and for integrating it into a broader set of capabilities.

**ASSET MANAGEMENT EXPERIENCE (A3, A31)**

The collective knowledge concerning assets, their disposition, and capacities to provide capabilities relevant to the establishment of direction to Defense activities.

**ASSET MANAGEMENT POLICY & GUIDANCE (A3, A31)**

Direction, including plans and orders, provided to asset managers regarding the control and disposition of assets, the determination of requirements for new/improved/replacement assets, and the mechanisms through which assets are managed.

**ASSET MANAGERS ( A31)**

Organizations or individuals throughout the enterprise with the responsibility and authority to manage assets.

**ASSET SPECIFICATIONS (A2, A22, A23)**

Documentation which defines the required technical characteristics of an asset, including its form, fit, function, and the limits or tolerances within which the asset must be produced. Items are produced to meet the designs, but are inspected or tested to the specifications.

**APPENDIX B**  
**ACTIVITY MODEL GLOSSARY**

---

**ASSET STATUS (A0, A2, A21, A3, A31)**

Condition of assets in the Defense inventory that can be used in the conduct of Defense activities, specification of assets that are needed to augment the inventory, and evidence pertaining to the performance of assets that have been acquired through agreements.

**ASSET - SPECIFIC REQUIREMENTS (A2, A21, A22, A23)**

Functional and technical descriptions of the quantitative and qualitative need for the asset, which, when properly documented and authorized, lead to the acquisition of assets. These requirements may be transmitted in solicitations, as purchase orders, as personnel position descriptions, etc.

**ASSETS (A0, A3, A32, A33)**

*Materiel* (such as weapon systems, information systems hardware, equipment), people, services, facilities, real estate, intellectual property (such as asset designs, research, software, rights of access and use), and the electro-magnetic spectrum required to conduct Defense activities.

**ASSETS AVAILABLE (A31)**

Assets in the Defense inventory that are uncommitted and can be used in the conduct of Defense activities.

**ASSETS FOR SUSTAINING PEOPLE (A44)**

Assets in the Area of Responsibility that are used to sustain people, (e.g., food, clothing, shelter, etc.).

**ASSETS NEEDED & PERFORMANCE (A31)**

Specification of assets that are needed to augment the inventory and evidence pertaining to the performance of assets acquired through agreements.

**APPENDIX B  
ACTIVITY MODEL GLOSSARY**

---

**ASSETS NEEDING RESUPPLY (A44)**

Assets in the Area of Responsibility that need to be provided with items necessary to their proper functioning, such as replacement parts, food, fuel, and ammunition.

**ASSETS NEEDING SUSTAINING (A4, A43, A44)**

Assets in the Area of Responsibility that need sustainment, (e.g., people, weapon systems, etc.).

**ASSETS TO BE MOVED (A44)**

Assets that need to be re-positioned within the Area of Responsibility from one geographical location to another.

**ASSETS TO BE SUPPLIED (A44)**

Assets in the Area of Responsibility that are used to resupply (other) assets.

**AUDITED RECORDS (A33)**

Financial records that have been examined for discrepancies, errors, and accidental or intentional misrepresentations.

**AUTHORIZATION TO ENHANCE (A32)**

Authorization to improve the performance of assets. It includes authorization to provide training for individual skill advancement and career progression, as well as authorization to refurbish and modify materiel and facilities to improve performance and functionality.

**AUTHORIZATION TO MAINTAIN (A32)**

Authorization to care for people, materiel, and real property. It includes authorization to provide health services to military and civilian personnel as well as authorization to perform preventive maintenance and repairs on materiel and real property.

---

**APPENDIX B  
ACTIVITY MODEL GLOSSARY**

**AUTHORIZATION TO SEPARATE (A32)**

Authorization to remove assets from accessibility by the enterprise.

**AUTHORIZATION TO TRANSPORT (A32)**

Authorization to physically relocate assets and units to designated locations for carrying out Defense activities, and to recover, account for, and redeploy personnel and materiel from an area of operation. It includes authorization for inter-theater transportation but not intra-theater movement. It includes authorization for the recurring peacetime transport of assets for unit replacement, support, or separation, as well as the transport of service members, their families, and their property.

**AWARE PEOPLE (A33)**

Inquiring people who have been provided information and advice pertaining to personal concerns considered non-integral to their normal Defense activities. Information and advice can be in the form of explanations of health benefits, legal rights, personnel policy, and job openings.

**BUDGETS & AUTHORIZATIONS (A1, A14, A2, A21, A3, A33, A4, A41)**

Fiscal resources, financial plans, and approval needed to expend funds and implement the activities associated with providing for the common Defense.

**CAPABILITIES (A0, A1, A14, A2, A22, A23, A3, A34, A4, A41)**

A defined set of ready assets that have been integrated to carry out one or more Defense activities.

**CAPABILITIES REQUIRING TRAINING (A34)**

Organizations and units that require institutional/unit training to achieve required levels of readiness.

**APPENDIX B  
ACTIVITY MODEL GLOSSARY**

---

**CAPABILITIES TO CONSTITUTE FORCES (A4, A41)**

Actions and decisions required to form a warfighting force.

**CAPABILITIES TO DETERMINE REQUIREMENTS (A1, A12)**

The ability to identify doctrinal, organizational, and resource needs necessary to provide for the common Defense.

**CAPABILITY ASSESSMENTS (A12)**

The evaluation of all Defense capabilities expected to accomplish assigned missions and business activities, as prescribed by appropriate criteria. This ranges from assessment of warfighting capabilities to assessment of the conduct of normal peacetime operations.

**CAPABILITY DEFICIENCIES (A12)**

Shortcomings in capabilities that result in insufficient capacity or quality to perform designated missions.

**CAPABILITY IMPLICATIONS (A0, A3)**

A measure of the contribution to the level of effort that can be expected from the activities and mechanisms that support assets and develop capabilities. The demonstration of capabilities has strategic implications to those who are deterred by the perceived threat implicit in those capabilities as well as those who feel reassured by those capabilities.

**CAPABILITY LIMITATIONS (A12)**

Constraints placed on designated capabilities that limit their availability or assignment for Defense requirements. An inherent shortcoming of a proposed capability that has been found to be insurmountable and calls into question policy.

---

**APPENDIX B  
ACTIVITY MODEL GLOSSARY**

**CIVILIAN POPULATION (A-0, A0, A2, A23)**

The current and projected future pool of manpower and skills that the DoD can draw upon to produce military and civilian personnel.

**COMMAND FORCE STRUCTURE (A41)**

Numbers, size, and composition of the units under the command of one individual that comprise Defense forces.

**COMMERCIALLY AVAILABLE PRODUCTS & SERVICES (A23)**

Items and services regularly used in the normal course of business for non-government purposes that have been sold, leased, or licensed to the general public; have been offered for sale, lease, or license to the general public; are not yet available in the commercial marketplace but will be available in time to satisfy delivery requirements under a government solicitation; or are items that, but for minor modification made to meet government requirements, would satisfy the aforementioned criteria.

**COMMITTED RESOURCE IMPLICATIONS (A1, A14)**

The strategic and tactical impact of resources that have been apportioned to Defense activities. The intent to commit resources to Defense activities has strategic implications to those who feel threatened by the commitment as well as to those who feel reassured.

**CONSTRUCTION EXPERIENCE (A23)**

Knowledge gained in the construction process. This knowledge provides both status of current projects and a base of knowledge about the process itself.

**CONSTRUCTION RESOURCES (A23)**

That which can be obtained from the domestic and international marketplace for use in the construction of assets.

**APPENDIX B**  
**ACTIVITY MODEL GLOSSARY**

---

**CONTRACT PERFORMANCE (A21)**

Information on how well a contractor has performed (product quality, cost, and schedule) on a particular contract.

**DEFENSE CAPABILITY REQUIREMENTS (A1, A12, A13)**

The definition of needs to conduct or support Defense activities.

**DEFENSE POLICY & GUIDANCE (A-O, A0, A1, A11, A13, A14, A2, A21, A3, A32, A33, A34, A4)**

Direction that sets goals and objectives; establishes rules, methods, and procedures; enforces behavior of people providing for the common Defense; and descriptions of intentions and rationales provided to external constituencies, such as the President, Congress, the public, and Allies.

**DEMONSTRATED ABILITY TO ENHANCE (A32)**

A measure perceivable to adversaries and Allies of the enterprise's ability to improve the performance of assets. It includes the ability to provide training for individual skill advancement and career progression, and to refurbish and modify materiel and facilities to improve performance and functionality.

**DEMONSTRATED ABILITY TO FORM CAPABILITIES (A3, A34)**

A measure perceivable to adversaries and Allies of the enterprise's ability to train and create capabilities that are adequate to perform assigned missions or Defense activities.

**DEMONSTRATED ABILITY TO MAINTAIN (A32)**

A measure perceivable to adversaries and Allies of the ability of the enterprise to care for people, materiel, and real property. It includes abilities to provide health services to military and civilian personnel and to perform preventative maintenance and repairs on materiel and real property.

---

**APPENDIX B  
ACTIVITY MODEL GLOSSARY**

---

**DEMONSTRATED ABILITY TO SEPARATE (A32)**

A measure perceivable to adversaries and Allies of the enterprise's ability to remove assets from accessibility.

**DEMONSTRATED ABILITY TO SUSTAIN OPERATIONS (A4, A44)**

A measure perceivable to adversaries and Allies of the ability of forces in the Area of Responsibility to maintain materiel, sustain people, resupply items, and move before, during, and after termination of operations.

**DEMONSTRATED ABILITY TO TRANSPORT (A32)**

A measure perceivable to adversaries and Allies of the enterprise's ability to physically relocate assets and units to designated locations for carrying out Defense activities, and to recover, account for, and redeploy personnel and materiel from an area of operation. It includes inter-theater transportation but not intra-theater movement. It includes the recurring peacetime movement of assets for unit replacement, support, or separation, as well as the movement of service members, their families, and their property.

**DEMONSTRATED COMMAND CAPABILITY (A41)**

A measure perceivable to a potential adversary of the ability of US, allied, and coalition forces to integrate forces and provide effective command and control over all forces.

**DEMONSTRATED FORCE CAPABILITY (A41)**

Identifiable actions that a force or element of a force can successfully take in contributing to a military action.

**DEMONSTRATED STATE OF ADMINISTRATIVE READINESS (A3, A33)**

A measure perceivable to adversaries or Allies of the enterprise's ability to provide administrative services.

**DEMONSTRATED STATE OF SUPPORT READINESS (A3, A32)**

A measure perceivable to adversaries or Allies of the enterprise's ability to support assets.

---

**APPENDIX B  
ACTIVITY MODEL GLOSSARY**

---

**DESIGN CAPABILITIES (A22)**

Those integrated assets with the ability to perform the design process and produce designs and specifications.

**DESIGN DEFICIENCIES (A22)**

Problems in a design that are revealed in prototyping or other demonstrations and which lead to redesign or consideration of design alternatives.

**DESIGN EXPERIENCE (A22)**

Knowledge gained in the design process. This knowledge includes both status of a design process and provides lessons learned about the process.

**DETAILED PLANNING GUIDANCE (A13)**

Specific information that a member of DoD gives to subordinates to facilitate a thorough understanding of an assigned task, mission, attendant restrictions, and considerations so that a plan may be devised.

**DIRECTION TO GATHER & ANALYZE INTELLIGENCE (A11)**

Authoritative guidance provided that directs that information be collected and assessed on foreign countries or areas.

**DISCREPANCIES/VOIDS (A42)**

Disparities in intelligence information and unfulfilled intelligence requirements that require resolution or identification.

**DOCTRINAL DEFICIENCIES (A12)**

Fundamental principles by which the military forces, or elements thereof, guide their actions in support of national Defense that are lacking in necessary quality.

---

**APPENDIX B  
ACTIVITY MODEL GLOSSARY**

---

**DOCTRINAL GUIDANCE, FORCE STRUCTURES (A1, A12)**

Directive information regarding the fundamental principles by which the military forces guide their actions in support of national Defense specific to force structures.

**DOCTRINE ANALYSTS & TOOLS (A12)**

DoD personnel assigned to assess doctrine and the means by which they conduct that assessment.

**DOCTRINE & FORCE STRUCTURE IMPLICATIONS (A1)**

The impact that specific doctrine and force structures have on the identification of requirements leading to the development of a plan.

**DOCTRINE & PROCEDURES (A12)**

Fundamental principles by which the military forces, or elements thereof, guide their actions in support of national Defense and the means by which Defense doctrines are implemented.

**DOCTRINE CHANGES (A12)**

Modification of the fundamental principles by which military forces, or elements thereof, guide their actions in support of national military objectives.

**DOCTRINE IMPLICATIONS (A12)**

The strategic and tactical impact that developed doctrines have on those who feel threatened by US military force as well as those who feel reassured by it.

**ENHANCED ASSETS (A32)**

Assets that have undergone a process to improve their performance and are judged to be ready for integration into a broader set of capabilities. The enhancements include training for individual skill advancement and career

**APPENDIX B  
ACTIVITY MODEL GLOSSARY**

---

progression, and the refurbishment and modification of materiel and facilities to improve their performance and functionality.

**ENHANCEMENT PROGRESS (A32)**

Measurement of advancement toward goals of asset enhancement due to improvements implemented within schedule and cost constraints.

**EXECUTIVE, JUDICIAL & CONGRESSIONAL AUTHORITIES (A-O, AO, A1, A11)**

Executive, Judicial, and Legislative Branch direction that affects Defense activities involved in providing for the common defense.

**EXPERIENCED ASSETS (AO)**

Assets that are serving in the conduct of Defense activities or are in inventory and are available for use.

**FACILITIES REQUIRING SERVICES (A33)**

Workplaces that require a variety of administrative services, such as maintaining security, operating photocopiers, scheduling conference rooms, taking messages — the many support activities that allow a facility to function.

**FEDERAL REGULATIONS (A-O, AO)**

Body of law, regulation, policy, and standards that guide and control government and industry actions.

**FINANCIAL RECORDS (A33)**

Historical registries of events and circumstances that are significant to the orderly and legal dispersal, use, and collection of money.

**APPENDIX B  
ACTIVITY MODEL GLOSSARY**

---

**FINANCIAL TRANSACTIONS (A33)**

Directives to take action in matters involving individual assets and money, such as paying military and civilian employees and reimbursing travel expenses.

**FORCE IMPLICATIONS (A0, A4, A41)**

The demonstration that the enterprise supports the political will of the US when required, and the tactical and strategic impact of a fielded force on those who feel threatened by US military force as well as those who feel reassured by it.

**FORCE INTEGRATION TASKING (A41)**

Authoritative direction regarding formation of organizational elements from individual military and civilian personnel and materiel items that have been assigned.

**FORCE STATUS (A4, A41, A42, A43, A44)**

The current status of specific forces including equipment, personnel readiness, and their equipment and their overall capability to perform assigned tasks.

**FORCE STRUCTURING CAPABILITIES (A12)**

Methods, tools, and techniques (including modeling and simulation) for sizing and shaping the force.

**FOUNDATIONS OF NATIONAL STRATEGY (A11)**

The established principles and authorities by which the National Security Council gives advice on integrating domestic, foreign, and military policies as they relate to national security.

**APPENDIX B  
ACTIVITY MODEL GLOSSARY**

**FULFILLMENT & LEVELING OPTIONS (A31)**

Approaches or techniques (e.g., substitution, cross-leveling, redistribution) used to correct variances between levels of assets required and assets available.

**FUNDING (A21)**

Authority to obligate or commit the Government to a specific expenditure.

**GEOPOLITICAL IMPLICATIONS (A11)**

The anticipated impact on a military plan of a foreign nation's geographical and political situations that exist or are reasonably expected to exist.

**GLOBAL DEFENSE ESTABLISHMENT IMPLICATIONS (A11)**

Potential impact on relevant world-wide political, economic, and military establishments as a result of the establishment of Defense priorities and strategies.

**GOVERNMENT FURNISHED ASSETS (A0, A2, A22, A23)**

Assets provided from the Defense and other government inventories for use in developing new assets.

**INDIVIDUALS & FAMILIES (A33)**

Military and civilian personnel and their families, and certain contractor employees and allied personnel, and in certain instances their families, who are entitled to services that sustain them in their communities.

**INDUSTRIAL RESOURCES (A-0, A0, A2, A23)**

That which can be obtained from the domestic and international marketplace, such as facilities, materials, technology, commodities, commercially available products and services, and real estate.

**APPENDIX B**  
**ACTIVITY MODEL GLOSSARY**

---

**INFORMATION SYSTEMS REQUIRING SERVICES (A33)**

Computers, networking and telecommunications equipment, data processing installations, and other such physical information-management equipment and facilities that require continuous remedial attention in order to continue adequate operation.

**INITIAL TASKING (A13)**

Direction that a Commander provides early in a planning evolution specific to mission, assumptions, nuclear and chemical warfare, political considerations, and tentative courses of action.

**INQUIRING PEOPLE (A33)**

People in need of explanations, facts, expert opinions, and general guidance in matters of personal concern.

**INTEGRATION CAPABILITIES (A34)**

The capabilities applied by the enterprise to form organizational elements from individual assets that have been assigned to units, in order to establish capabilities that are required for the accomplishment of missions related to the common Defense.

**INTEGRATION DEFICIENCIES (A34)**

Shortcomings in unit/organizational proficiency to accomplish potential missions that are attributed to the inadequate or incomplete integration of ready assets.

**INTEGRATION STATUS (A41)**

The current level of success regarding the intentional formulation of organizational elements from individual military and civilian personnel and materiel items that have been assigned.

**APPENDIX B**  
**ACTIVITY MODEL GLOSSARY**

---

**INTELLIGENCE (A1, A11, A12, A13)**

The product resulting from the collection, processing, integration, analysis, evaluation, and interpretation of available information concerning foreign countries or areas.

**INTELLIGENCE EXPERIENCE (A42)**

Knowledge gained from the collection and analysis of available information concerning potential and actual threats, situations, and environments.

**INTENTIONS, THREAT CAPABILITIES & OPERATIONAL ENVIRONMENT (A42)**

The supposition that a potential adversary will act in a certain way, assessments regarding their resources and assets that have the ability to perform militarily related functions, and assessments regarding the geographical and political operating environment of military significance that is disseminated to Commanders derived from intelligence gathering.

**INTERNATIONAL & DOMESTIC COMMUNITY (A-0, A0, A4, A42, A43)**

The aggregation of foreign and US bodies of government and related societies.

**ISSUES WITH CAPACITIES & ASSIGNMENTS (A31)**

Problems in fulfilling support and development decisions that cannot be remedied by changing asset dispositions or assignments, and must be addressed by changing plans or allocations. Examples include insufficient capacity, scheduling conflicts, lack of readiness to provide support, and other unresolved discrepancies.

**JOINT/COMBINED FORCES (A4, A41, A43, A44)**

Joint (multi-service) US forces and as required, combined and allied US coalition forces, working together toward a common military objective under a unified command structure.

**APPENDIX B  
ACTIVITY MODEL GLOSSARY**

---

**KNOWLEDGE, SKILLS, ABILITIES, SCIENCE & TECHNOLOGY (A22)**

The physical, technical, scientific, educational, intellectual, and other pertinent attributes associated with the development of an asset design.

**LEVEL OF DETERRENCE & ASSISTANCE/PROSECUTION OF CONFLICT (A4, A43)**

The degree to which military action deters aggression, keeps the peace, resolves conflicts using military force, provides assistance to people, and achieves other assigned missions.

**LEVEL OF RESPONSE (A-O, AO)**

The nature and degree of activity generated within and throughout the DoD in response to actual and potential threats, aggressions, and requests for assistance, including deterrence and activities perceivable by the enemy.

**MAINTAINED ASSETS (A32)**

Assets whose normally-occurring needs for remedial attention have been addressed.

**MAINTENANCE PROGRESS (A32)**

Measurement of advancement toward preventing and remedying disrepair and injury in assets.

**MANUFACTURING EXPERIENCE (A23)**

Knowledge gained in the manufacturing of a product. This knowledge provides both the status of current projects and a base of knowledge about the process itself.

**MANUFACTURING RESOURCES (A23)**

That which can be obtained from the domestic and international marketplace for use in the manufacturing of potential assets.

---

**APPENDIX B  
ACTIVITY MODEL GLOSSARY**

---

**MATCHED REQUIREMENTS (A31)**

Indication that required levels of assets are available to meet requirements.

**MISSION CRITERIA (A34)**

The body of doctrine, directives, plans, orders, standards, criteria, and other documentation that provide guidance, boundaries, goals, and objectives for training programs.

**MISSION READY ASSETS IN POSITION (A44)**

Mission-ready materiel, people, and other assets in the Area of Responsibility that are in their assigned geographical location.

**MISSION READY ASSETS TO BE MOVED (A44)**

Mission-ready materiel, people, and other assets in the Area of Responsibility that need to be moved from one geographical location to another.

**MISSION READY MATERIEL (A44)**

Materiel assets that are ready to be employed in conventional, nuclear, space, special, and inter/intra governmental operations.

**MISSION READY PEOPLE (A44)**

Military and other personnel who are equipped, trained, supplied, fit, and otherwise ready to engage in operations in the Area of Responsibility.

**MOVED ASSETS (A44)**

Assets, whether mission ready or in need of sustainment, that are in their assigned geographic location.

---

**APPENDIX B  
ACTIVITY MODEL GLOSSARY**

**NATIONAL ECONOMIC, POLITICAL & MILITARY ESTIMATES (A11)**

US assessment of the economic, political and military factors of pertinent countries throughout the world that significantly influence the establishment of national security priorities.

**NATIONAL INTELLIGENCE (A4, A42)**

Elements of information concerning foreign countries or areas that cover broad aspects of national policy and national security, is of concern to more than one department or agency, and transcends the exclusive competence of a single department or agency.

**NATIONAL MILITARY INTELLIGENCE ESTIMATES (A11)**

US intelligence assessment on any foreign military or military-related situation or activity which is significant to military policy making or planning.

**NATIONAL MILITARY STRATEGY (A1, A12)**

The art and science of using the nation's armed forces, during peace and war, to secure national objectives.

**NATIONAL MILITARY STRATEGY & POLICIES (A11)**

The art and science of using the nation's armed forces, during peace and war, to secure national objectives and the development of policies that act as the vehicle for expressing and guiding the strategy.

**NATIONAL SECURITY STRATEGY (A11)**

The aggregation of the national Defense and foreign relations of the United States, using US political, economic, and psychological powers, together with its armed forces, during peace and war, to develop: a military or Defense advantage over a foreign nation or group of nations; a favorable foreign relations position; or a defensive posture capable of successfully resisting hostile or destructive action.

**APPENDIX B  
ACTIVITY MODEL GLOSSARY**

---

**NEED FOR RELIEF FROM RESTRICTIONS OR REQUIREMENTS (A31)**

The necessity to modify constraints, reduce the quantity of assets needed, and/or change the time sequence when assets are needed.

**NEW ASSETS (A0, A2, A23)**

Potential assets that are delivered, certified, and accepted for Defense use. Such assets include government furnished assets that have undergone changes so fundamental that the resulting asset is considered to be new.

**OBLIGATIONAL AUTHORITY & AUTHORIZATION (A1, A14)**

The vested ability to make a decision to use DoD-allocated fiscal resources to acquire and use people, goods, and services to provide programmed Defense capabilities.

**OFFERS, PROTESTS, & AGREEMENT - DEFINED SUBMITTALS (A2, A21)**

Virtually all formal communications to the Government, other than queries from contractors, during the acquisition life cycle.

**OPERATIONAL EXPERIENCE (A0, A1, A11, A12, A13, A2, A21, A3, A4)**

Evidence obtained from the conduct of all Defense activities, including successes and failures in military operations, that represents the factual basis for assessing and improving the direction that guides Defense activities.

**OPERATIONAL EXPERIENCE WITH EXISTING PROGRAMS (A14)**

Actual experience with existing Defense-related programs obtained from the conduct of Defense activities, including successes and failures in military operations, resulting in the ability to produce, buy, and recruit suitable assets, and the capability to deploy and employ forces in support of military missions.

**APPENDIX B  
ACTIVITY MODEL GLOSSARY**

---

**OPERATIONAL INTELLIGENCE (A4, A41, A43)**

Information gathered about a foreign country or area required for planning and executing a military mission.

**OPERATIONAL INTELLIGENCE NEEDS (A42)**

The requirement to provide an information product resulting from the collection, processing, integration, analysis, evaluation, and interpretation of available information concerning foreign countries or areas required by a Commander for planning and executing military missions.

**OPERATIONAL INTELLIGENCE PRODUCTS (A42)**

The analyzed output of information gathered about a foreign country or area required for planning and executing a military mission that is disseminated to Commanders to aid in the assessment of threat intentions, capabilities, and operational environment, and the conduct of operations.

**OPERATIONAL TASKING (A4, A41, A43, A44)**

Requirements for sustainment of direct operations linked to the scheme of maneuver, level of combat intensity, and other operational parameters.

**ORDERS (A13)**

Specific direction given by an authority that guides the actions of DoD forces during the execution of Defense activities.

**ORGANIZATION LIMITATIONS (A12)**

Constraints inherent in the management, people or equipment of an organization that limit its effectiveness.

---

**APPENDIX B  
ACTIVITY MODEL GLOSSARY**

---

**ORGANIZATION STRUCTURE DEFICIENCIES (A12)**

Weapons, people, supplies, and facilities that are required for the formulation of a military organization that are lacking in quantity or necessary quality.

**ORGANIZATION STRUCTURE REQUIREMENTS (A12)**

The identification of weapons, people, supplies, and facilities that are required for the formulation of a military organization.

**ORGANIZATION STRUCTURES (A12)**

The structuring of people, goods, and services into operational forces.

**PEOPLE NEEDING SUSTAINING (A44)**

People in the Area of Responsibility who need to be fed, housed, clothed, moved, given medical care, or otherwise sustained.

**PLAN & ORDER DISCREPANCIES & ADJUSTMENTS (A41)**

Identified deficiencies in an existing military or national plan or order that produces the requirement to reassess and revise the plan or order.

**PLANNED CAPABILITIES (A1, A13, A14)**

Identified resources that have been deemed necessary in order to accomplish the objectives of a plan.

**PLANNING CAPABILITIES (A1, A13)**

Joint Strategic Planning System (JSPS) is the formal means by which the Chairman, Joint Chiefs of Staff (CJCS) discharges his responsibility to give strategic plans and direction to the armed forces and to interact with the Planning, Programming, and Budgeting System (PPBS).

**APPENDIX B  
ACTIVITY MODEL GLOSSARY**

---

**PLANNING GUIDANCE (A1, A12, A13)**

Direction provided to planners by higher level authorities within DoD.

**PLANS (A13)**

The aggregation of needs determinations that are expressed in a context of a definable requirement or mission to which a civilian or military authority can formulate a course of action that will allow that authority to fulfill the requirement.

**PLANS & ORDERS (A1, A13, A4, A41)**

Operational and support plans and attendant orders that implement policy and guidance.

**POTENTIAL CONSTRUCTED ASSETS (A23)**

Constructed objects which have been completed but for which the Government has not taken delivery nor has accepted.

**POTENTIAL MANUFACTURED ASSETS (A23)**

Manufactured items which have been completed but for which the Government has not taken delivery nor has accepted.

**POTENTIAL MILITARY & CIVILIAN PERSONNEL (A23)**

Individuals who are entering an active or reserve military status and civilians paid from appropriated or non-appropriated funds who have applied to work for the DoD in any of the DoD activities related to providing for the common Defense, but have not yet been received or accepted.

**APPENDIX B  
ACTIVITY MODEL GLOSSARY**

---

**PRODUCTION AGREEMENTS (A2, A23)**

Requirements definitions, terms, and conditions of the agreement which control the production of assets. Acceptance criteria are included in the agreement.

**PRODUCTION EXPERIENCE (A2, A23)**

The body of experience that results from involvement in the production phase of asset acquisition and which can help to define improvements to the acquisition process. This can include experience resulting from manufacturing, construction, and accession as well as experience resulting from taking delivery of assets, including rejected assets.

**PRODUCEABILITY ISSUES (A2, A22)**

Problems identified in the production of assets according to engineering specification and design criteria, and which can be used to improve or modify the engineering activity.

**PROGRAM BASELINES (A14)**

A definition of a program which forms the basis for its approval and control.

**PROGRAM DIRECTION (A21)**

A subset of Acquisition Guidance which sets the framework and limitations within which an acquisition program can be defined and administered. This information ranges from the DFARS to local small purchase procurement policy and procedure. It includes all required approvals for or rejections of all procurement approval requests, including approval or rejection of relief from restrictions (deviations and waivers).

**APPENDIX B  
ACTIVITY MODEL GLOSSARY**

**PROGRAM STATUS/NEED FOR RELIEF & APPROVAL (A21)**

Feedback on positive and negative aspects of ongoing programs to permit program redefinition or other adjustment when such actions will benefit the acquisition process. It includes all requested deviations, waivers, and relief from restrictions and all procurement approval requests.

**PROGRAMMING DEFENSE CAPABILITY (AO, A1, A14, A2, A21)**

Descriptions of capabilities, committed to and resourced through Executive and Congressional authorities, that lead to determination of requirements for assets needed to provide for the common Defense.

**PROGRAMS & BUDGETS (A-0, AO)**

Descriptions of what capabilities are needed to provide for the common Defense and the life cycle fiscal resources and financial plans associated with obtaining and supporting the capabilities.

**PROPOSED PROGRAMS/BUDGETS (A14)**

Service-prepared Program Objective Memoranda (POMs) that support their requirements to provide required Defense capabilities in consonance with Defense Policy and Guidance, existing program requirements, and service-specific criteria.

**PROPOSED PROGRAMS & ISSUES (A21)**

The initial design of individual regulations, policies, procedures, and programs that is submitted for approval for inclusion in Program Direction for the acquisition of new or replacement people, materiel, systems, goods, and services, including recommended/requested programmatic milestones and funding.

**READINESS CRITERIA (A34)**

The body of doctrine, directives, plans, orders, standards, criteria, and other directives that provide guidance, boundaries, goals, and objectives for unit/organizational readiness.

**APPENDIX B**  
**ACTIVITY MODEL GLOSSARY**

---

**READINESS, MODERNIZATION, SUSTAINMENT, FORCE STRUCTURES CRITERIA (A14)**

The four major elements of "military capability," which is the ability to achieve a specified wartime objective, include the following: *Readiness*, the ability of forces, units, weapon systems, or equipment to deliver the outputs for which they were designed including the ability to deploy and employ without unacceptable delays. *Modernization*, the technical sophistication of forces, units, weapon systems, and equipment. *Sustainment*, the ability to maintain the necessary level and duration of operational activity to achieve military objectives. *Force structure*, the number, size, and composition of units that comprise our Defense forces. These four elements are the criteria for balancing and approving Defense programs.

**READINESS STATUS (A3, A34)**

Readiness matrix that represents the performance of particular capabilities through which they have demonstrated their readiness to carry out Defense activities.

**READY ASSETS (A3, A32, A33, A34)**

Assets that are fully prepared to contribute to the successful execution of missions and other enterprise activities.

**REJECTS (A23)**

Those items or personnel which, upon examination, are found to be outside the limits of the asset specifications. These rejects may leave the enterprise or may be returned to their source for re-manufacture, re-construction, or re-accession.

**REPLANNING REQUIREMENTS (A13)**

The need to revise previous planning in order to respond to unforeseen events or surmount unsuccessful execution of a previous plan.

---

**APPENDIX B  
ACTIVITY MODEL GLOSSARY**

---

**REQUIREMENTS FOR ASSETS (A21)**

Asset requirements that have been judged to be valid in terms of asset status (need) and design and production experience (feasibility), but which still need to be defined and justified in terms of cost (time and money) and benefit prior to a decision on acquisition.

**RESEARCH CAPABILITIES (A22)**

Public and private laboratories, universities, and research centers which have the ability to do research.

**RESEARCH, DESIGN & PRODUCTION EXPERIENCE (A2, A21)**

The conjunction of Research, Design, and Production Experience. It is the body of knowledge that is gained from involvement in performing the process and which can help to define improvements to the process. It also provides status on the progress of the process. It includes knowledge of rejected assets.

**RESEARCH/DESIGN AGREEMENTS (A2, A22)**

The conjunction of Research Agreements (sometimes Contracts) and Design Agreements. It includes requirements definitions, terms, and conditions of the agreement which control the research and design activities. Acceptance criteria are included in the agreement.

**RESEARCH/DESIGN EXPERIENCE (A2, A22)**

The conjunction of Research and Design Experience. It is the body of knowledge that is gained from involvement in the performing the process and which can help to define improvements to the process. It also provides status on the progress of the process.

**RESEARCH EXPERIENCE (A22)**

The body of knowledge that is gained from involvement in the performing research and which can help to define improvements to research activities. It also provides status on the progress of the research.

---

**APPENDIX B  
ACTIVITY MODEL GLOSSARY**

---

**RESEARCH RESULTS (A22)**

Basic and applied knowledge that is of potential use in designing and developing assets, including knowledge and skills that could perform generic functions.

**RESOURCE ALLOCATION GUIDANCE (A14)**

Fiscal guidance prepared in consonance with Defense Policy and Guidance that reflect Program Objectives Memoranda (POM) submission requirements, formats, review criteria, and other fiscal constraints to be considered in preparing Proposed Programs and Budgets.

**RESOURCE AREA DECISIONS & ADJUSTED ASSUMPTIONS (A31)**

Decisions that will affect availability of assets, expressed in terms of resource areas: manpower, materiel and equipment, transportation, facilities, industrial base, training base, medical, communication-electronics, host nation, environment, legal, and funding; and guidance based upon assumptions that earmark assets contingent on the outcome of seeking relief from restrictions or requirements.

**RESOURCE SHORTFALLS (A1, A13, A14)**

Identified deficiency in the number of people, goods, or services required to fully prosecute a military mission or support requirement. A shortfall does not necessarily preclude the successful accomplishment of a mission, but effects the planning process by imposing less than optimum assets thereby potentially increasing the risk which a commander will face.

**RESUPPLIED ASSETS (A44)**

Assets that have been provided with the supplies needed to perform specified functions.

**SELECTED COURSES OF ACTION (A13)**

Plans that would accomplish, or are related to the accomplishment of, a mission.

**APPENDIX B  
ACTIVITY MODEL GLOSSARY**

---

**SENIOR DEFENSE LEADERSHIP, POLICY/INTELLIGENCE ANALYSTS (A1, A11)**

Civilian and military personnel within DoD that have been vested with the responsibility to approve policy that has the potential to effect a wide array of DoD actions. Civilian and military personnel within DoD who are vested with the responsibility of assessing National and Defense policies that contribute to the establishment of national security priorities and Defense priorities and strategies. Civilian and military personnel within DoD who are vested with the responsibility of providing intelligence assessments that contribute to high level decision making regarding the current and projected disposition of DoD resources.

**SEPARATED ASSETS (A-0, A0, A3, A32)**

Assets from the Defense inventory that have been permanently eliminated to an Ally and as such are not available for use in providing for the common Defense. Permanently eliminated assets include assets that are no longer needed to fulfill the Defense mission, are obsolete, are damaged beyond repair, or meet other specified separation criteria and have been selected to be eliminated from the inventory. Such assets are not subject to recall but may be tracked by the government to satisfy statutory or regulatory mandates.

**SEPARATION PROGRESS (A32)**

The status of asset separation activities, and the final disposition of the asset.

**SERVICED INFORMATION SYSTEMS (A33)**

Computers, networking and telecommunications equipment, data processing installations, and other such physical information-management equipment and facilities that have received continuous remedial attention and can continue normal operation.

**SOLICITATIONS, AGREEMENTS & AGREEMENT-DEFINED TRANSACTIONS (A2, A21)**

Communications from the DoD to those who want to do business with or otherwise work with the Department. Solicitations include, but are not limited to, public announcements, requests for proposals, quotes, sources

---

## APPENDIX B ACTIVITY MODEL GLOSSARY

sought, expressions of interest, capability statements, and notices of intent. Agreements include, but are not limited to, all contracts and contract modifications, purchase orders, Memoranda of Agreement or Understanding, Cooperative Agreements, and Grants. Agreement-defined transactions include, but are not limited to, notifications of cancellation, acceptance, payment authorization, and certification or deficiency.

### STATE OF THE ART (A2, A22)

The highest level of development, as of a device or technique, that has been achieved in science or industry at any particular time.

### STATUS OF OPERATIONS (A4, A43)

The progress of an operation towards fulfilling its intended mission and objectives.

### STRATEGIC IMPLICATIONS (A0, A1, A11)

Possible significance of an event stemming from a broad military, diplomatic, economic, psychological or other related decision. Strategic implications affect the perceptions and actions of those who feel threatened by US force as well as those who feel reassured by it.

### STRATEGIC MILITARY OPTIONS (A11)

Achievable military options that result in the execution of a military mission directed against enemy targets with the purpose of destroying the enemy's war-making capacity and his will to make war.

### STRUCTURE IMPLICATIONS (A12)

The tactical and strategic impact of planned force structures on those who feel threatened by US military force as well as those who feel reassured by it.

**APPENDIX B  
ACTIVITY MODEL GLOSSARY**

---

**SUPPORT & DEVELOPMENT DECISIONS (A31)**

Decisions made by DoD asset managers regarding asset support, administrative services, and development of capabilities necessary to meet requirements.

**SUPPORT SYSTEMS, EQUIPMENT, FACILITIES, PERSONNEL, ETC. (A3, A32, A33)**

The life-cycle support systems, equipment, facilities, personnel, and other capabilities used to manage and support assets, provide administrative services, and develop capabilities.

**SUPPORTED FACILITIES (A33)**

Workplaces that have been provided continuous administrative services, such as maintaining security, operating photocopiers, scheduling conference rooms, taking messages — the many support activities that allow a facility to function.

**SUSTAINED ASSETS (A4, A41, A44)**

Assets in the Area Of Responsibility that have been sustained.

**SUSTAINED INDIVIDUALS & FAMILIES (A33)**

Military and civilian personnel and their families, and certain contractor employees and allied personnel, and in certain instances their families, who have been provided services that sustain them in their communities.

**SUSTAINMENT ASSETS (A4, A44)**

Assets in the Area Of Responsibility that are used to maintain materiel, sustain people, resupply, and move (other) assets needing sustaining. For example, ammunition is a resupply sustainment asset.

---

**APPENDIX B  
ACTIVITY MODEL GLOSSARY**

---

**SUSTAINMENT ASSETS TO BE MOVED (A44)**

Sustainment assets that need to be moved so they can be used to maintain materiel, sustain people, resupply, or support transportation/movement.

**SUSTAINMENT STATUS (A4, A44)**

The actual ability to sustain operations in the Area of Responsibility.

**TACTICAL INTELLIGENCE (A42)**

The communications, electronic signals, human and any other sources of data that are collected concerning foreign countries or areas for use by tactical commanders.

**TASKING GUIDANCE (A13)**

Upon identification of missions and objectives, direction which is issued by an authority which specifies assigned work leading to development of courses of action and plans.

**TECHNICAL DIRECTION (A21)**

The functional and technical parameters of a specific procurement that are to be satisfied through the DoD acquisition process. Procurement includes all purchasing of supplies and services ranging from major weapon systems through commercial commodities.

**TEST & EVALUATE CAPABILITIES (A22)**

Laboratories, ranges, and other staffed and equipped facilities that have the ability to conduct tests.

**TEST ARTICLES (A2, A22, A23)**

Those items which are to be tested or which will be used to facilitate tests. Test Articles for which the DoD has taken delivery are Government Assets; others are not.

---

**APPENDIX B  
ACTIVITY MODEL GLOSSARY**

---

**TEST PLAN REQUIREMENTS (A22)**

Documentation developed as a part of program guidance to establish criteria and timing for the testing of research results, designs, and test articles to demonstrate their compliance with specification.

**TEST RESULTS (A22)**

The documented outcome of tests, qualifications, certifications, demonstrations, and other means to measure compliance with specifications. The comparison of measured outcomes to the designed or planned consequence.

**TEST VOLUNTEER (A23)**

Selected individuals to test new ways to carry out Defense activities.

**THEATER/AOR INTELLIGENCE CAPABILITIES (A4, A42)**

The capabilities necessary to provide operational intelligence in the Theater/Area Of Responsibility, to include the fusing of national level intelligence with theater and tactical level intelligence, analysis, and the provision of intelligence products to operational and tactical commanders when and where needed, and in a form and media suited to the command/control and performance of the operation.

**THREATS/HOSTILE FORCES (A-0, A0, A4, A42, A43)**

Enemies and their resources, natural forces, and circumstances that put the national interests of the US at risk, such as willful adversaries preparing for or entering into hostile situations (e.g., war, terrorism, drug trafficking, information warfare), natural or man-made disasters caused by unleashed forces of nature, and conditions of life that threaten the survival of people who are important to our national interests.

**TRAINED CAPABILITIES (A34)**

---

**APPENDIX B**  
**ACTIVITY MODEL GLOSSARY**

Ready assets that have been integrated to form broader capabilities, and which have received training according to appropriate mission criteria to prepare them for the accomplishment of missions related to providing for the common Defense.

**TRAINING CAPABILITIES (A34)**

The capabilities applied by the Defense enterprise to train organizational elements according to appropriate mission criteria to prepare them for the accomplishment of missions related to the common Defense.

**TRANSPORT PROGRESS (A32)**

Measurement of advancement toward goals of transporting assets within schedule and cost constraints.

**TRANSPORTED ASSETS (A32)**

Assets that have been physically moved from one point to another, other than within a theater, as needed for the conduct of Defense activities. Transported assets include those that have been maintained and that may have undergone a process to enhance their performance. The transporting of assets involves their physical relocation in accordance with plans, requirements, and asset disposition and assignment decisions and it includes the recurring peacetime movement of assets for unit replacement, support, or separation, as well as the movement of service members, their families, and their property.

**UNACHIEVABLE FORCE STRUCTURES (A12)**

The number, size, and composition of units that are unattainable.

**UNACHIEVABLE POLICIES (A1, A11, A12)**

High level overall plans embracing general goals and procedures which are not able to be implemented.

**UNACHIEVABLE REQUIREMENTS (A1, A12, A13)**

**APPENDIX B  
ACTIVITY MODEL GLOSSARY**

Needs which are not able to be satisfied.

**UNATTAINABLE OBJECTIVES (A13)**

Desired aims or goals that are not able to be met.

**UNEXECUTABLE COURSES OF ACTION (A13)**

Plans that would accomplish, or are related to the accomplishment of, a mission that are not able to be executed.

**UNEXECUTABLE DOCTRINE (A12)**

Fundamental principles by which the military forces or elements thereof guide their actions in support of national defense which are not able to be executed.

**UNITED STATES GOVERNMENT, INDUSTRY BASE (AO)**

**UNRESOLVED ISSUES (A14)**

Fiscal constraints developed during the POM review process that have not been resolved by the services and OSD during the Planning, Programming and Budgeting process that require resolution prior to submitting the President's Budget.

**WORLD SITUATION (A-0, AO, A1, A11)**

Political, economic, military, and environmental circumstances that form the context for Defense decisions and plans. The World Situation includes public opinion, expectations of results arising from the application of military capabilities, and perceptions of acceptable military behavior.

**APPENDIX C**  
**DoD STRATEGIC DATA MODEL**

## DoD STRATEGIC DATA MODEL

This appendix presents the DoD Strategic Data Model in a series of IDEF1X diagrams. Section C.1 begins with a brief discussion on model notation and conventions. Section C.2 provides an overview of the DoD Strategic Data Model and thirteen views that detail the major data related priorities that are of interest to senior DoD officials. Section C.3 provides a discussion on intersecting entities. Section C.4 provides examples on using the DoD Strategic Data Model.

### C.1 IDEF1X DATA MODELING NOTATION

The DoD Strategic Data Model uses IDEF1X notation to describe information requirements that are critical to managing the Department of Defense. As an introduction to the notation used, the following sections provide a brief description of the IDEF1X syntax concerning entities and attributes, category notation, and relationships.

#### C.1.1 Entities and Attributes

In the DoD Strategic Data Model, an entity is a physical or conceptual object that is of interest to senior DoD officials who are responsible for managing the Department as a corporate enterprise. Focused on enterprise management, the strategic entity represents information about situations, resources, concepts, and assets that must be managed in order for the Department to succeed in its mission.<sup>4/</sup> The strategic entity represents information needs that have been selected by senior officials within the Department as being critical to the management of the Department.

In using IDEF1X to describe strategic information requirements, the DoD Strategic Data Model distinguishes between independent and dependent entities. The principal independent

---

<sup>4/</sup> This definition of an entity follows the principles of strategic data planning and practitioners of top-down information engineering and system design. One should also note that the entity labels used in the DoD Strategic Data Model are singular in nature. This is in keeping with proper data modeling conventions. For example, PERSON is the entity label assigned to the "People" data bucket described in Section 5.

entities are: ACTION, AGREEMENT, CAPABILITY, FACILITY, FUND, GUIDANCE, LOCATION, MATERIEL, ORGANIZATION, PERSON, PLAN, REAL ESTATE, and SITUATION. Figure C-1 shows the symbols associated with independent and dependent entities.

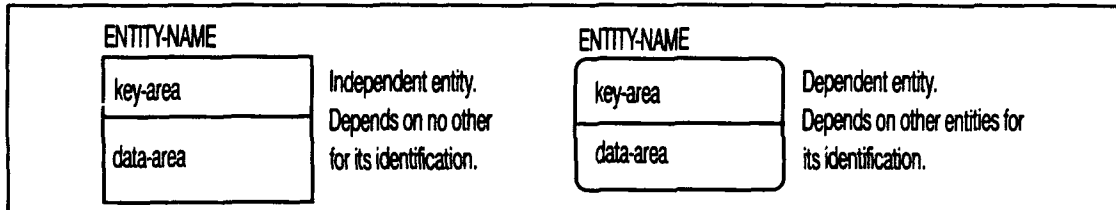

Figure C-1. IDEF1X SYMBOLS FOR INDEPENDENT AND DEPENDENT ENTITIES

Note: The area above the line is reserved for the identifying keys.

Each entity has attributes which are characteristics or properties that describe the entity. Attributes that uniquely identify individual instances of the entity are termed key-attributes; attributes not used for this purpose are termed non-key attributes. As shown in Figure C-1, key attributes are placed above the horizontal line within the entity box, and non-key attributes are placed below that line.

The DoD Strategic Data Model also categorizes attributes according to the use in either the key-area or the data area of the entity. For example, PERSON is an entity that has been selected for inclusion in the DoD Strategic Data Model. The primary key as shown in Figure C-2 is person-id. The foreign key (designated (FK)) is person-type-id.

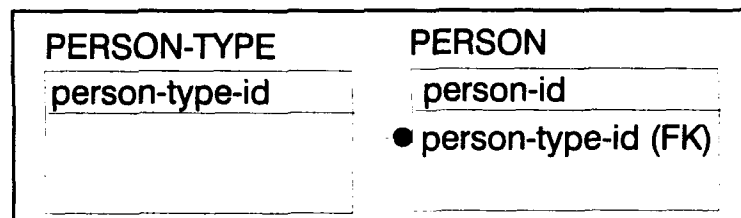

Figure C-2. PRIMARY AND FOREIGN KEYS

Non-key attributes that may be of strategic importance under the PERSON entity include the attributes: person-name and person-social-security-number. The DoD Strategic Data Model is a key-based data model in that all entities have primary keys and where appropriate show foreign keys.

### C.1.2 Category Notation

The DoD Strategic Data Model also uses an IDEF1X convention known as category notation. Figure C-3 shows the two types of category notation supported under IDEF1X.

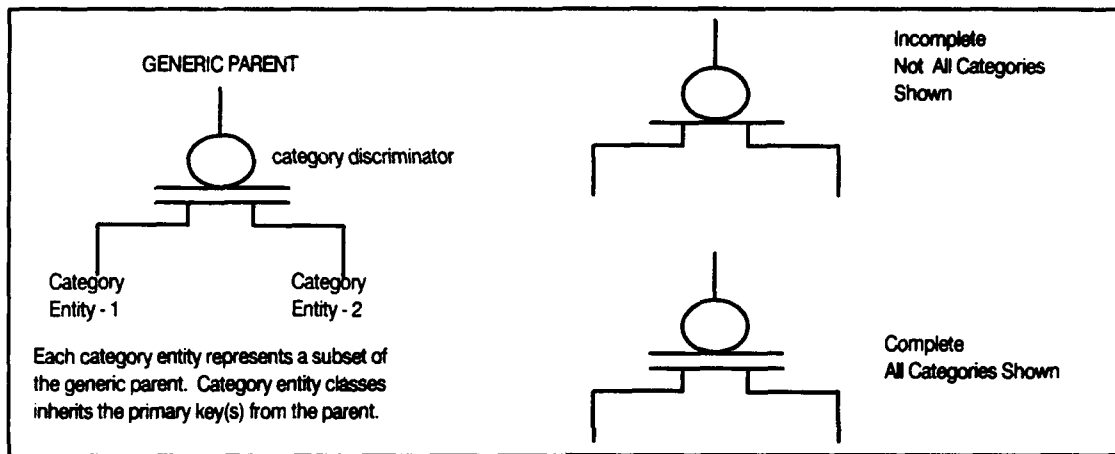

Figure C-3. IDEF1X SYNTAX FOR ENTITY CATEGORIES

In the DoD Strategic Data Model, a generic parent is generally one of the principal entities listed above. Category entities are used to represent subtypes of the generic parent. If the subtypes depicted are exhaustive, the category is complete and the double line is used to indicate this fact. If the subtypes depicted are only a fraction of the complete set, then the category is said to be incomplete and only one line is used in the symbol. Figure C-4 shows the use of the category notation for the entity PERSON.

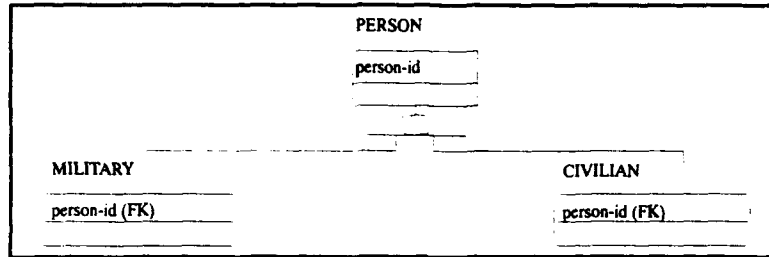

Figure C-4. CATEGORY NOTATION FOR ENTITY PERSON

### C.1.3 Relationship Notation

The DoD Strategic Data Model also uses IDEF1X notation for three main types of relationships that can exist between two entities. The general specification is shown in Figure C-5.

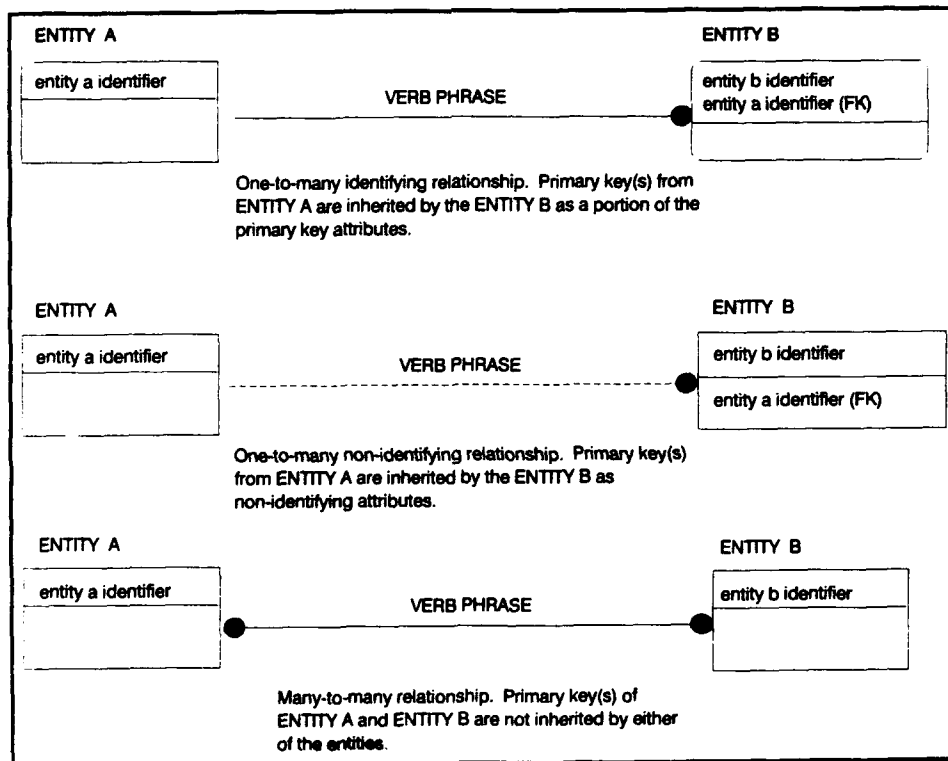

Figure C-5. IDEF1X RELATIONSHIP NOTATION

The DoD Strategic Data Model uses one-to-many identifying and one-to-many non-identifying relationships as shown in Figure C-5. The many-to-many relationship shown at the bottom of Figure C-5 is used to provide an executive overview of the data model on page C-7. These many-to-many relationships are not, however, shown in the data model views illustrated on pages C-8 to C-20. The many-to-many relationships are resolved by inserting an intersecting entity which allows us to relate primary entities to each other. An example is illustrated in Figure C-6 by the entity ORGANIZATION-PERSON.

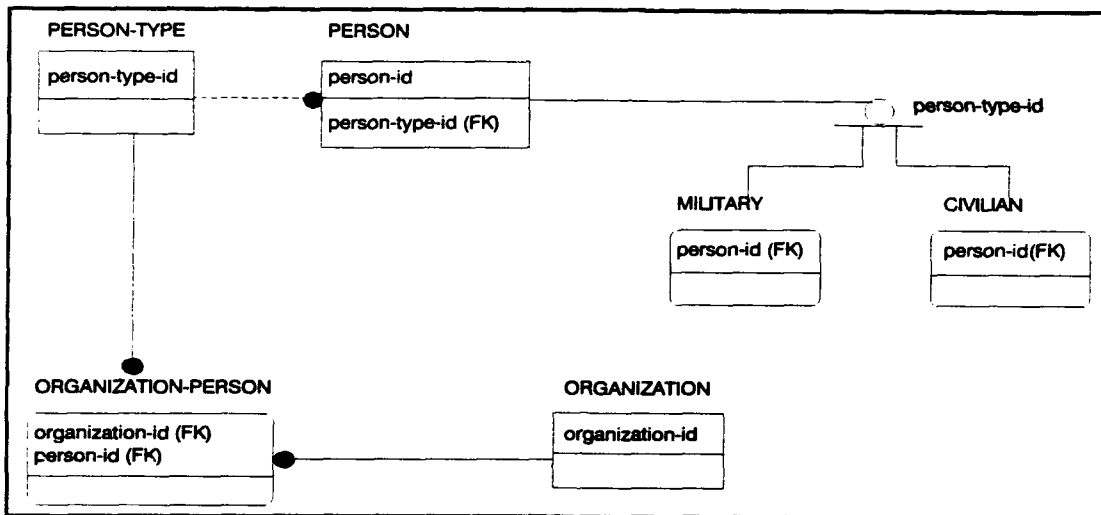

Figure C-6. RELATIONSHIP NOTATION IN DOD STRATEGIC DATA MODEL

Figure C-6 illustrates how entities, attributes, category entities, and relationships are depicted in the views the of DoD Strategic Data Model. ORGANIZATION-PERSON is an example of an intersecting entity that is dependent on both ORGANIZATION and PERSON and is used to resolve a many-to-many relationship. In this circumstance, the ORGANIZATION-PERSON entity allows us to associate a person (e.g., Jane Doe) to the organization that employs her (e.g., Defense Information Systems Agency).

The following summarizes the conventions used to present the DoD Strategic Data Model.

- (a) Independent entities are shown as a rectangular box.

- (b) Dependent entities are shown as a rounded rectangular box.
- (c) Attributes are contained in both the key-area and data-area of an entity. Nevertheless, the Strategic Data Model is a key-based data model as described under IDEF1X.
- (d) Category entities are shown as subtypes under principal entities.
- (e) Identifying relationships are shown as a solid line with a single dot at one end.
- (f) Non-identifying relationships are shown as a dashed line with a single dot at one end.
- (g) Intersecting entities are used to resolve many-to-many relationships between independent entities.

Additional information on modeling conventions can be found in several excellent sources on data modeling and IDEF1X techniques. Of special interest is the IDEF1X Federal Information Processing Standard (FIPS) which has been developed by the National Institute of Standards and Technology.

## **C.2 DoD STRATEGIC DATA MODEL**

The DoD Strategic Data Model is presented in pages C-7 through C-20. The Data Model consists of the following information:

- (a) Page C-8 illustrates an executive overview of the independent entities and the high-level relationships that exist between them.
- (b) Pages C-9 through C-21 presents the strategic view of each independent entity. These figures introduce the use of the category notation and intersecting entity as described above.
- (c) Pages C-22 through C-25 describes several intersecting entities in terms of the DoD business activities that are supported.

The information provided in Appendix D is also useful for examining the scope of the DoD Strategic Data Model. Appendix D includes definitions for each entity and attribute that is contained in the DoD Strategic Data Model.

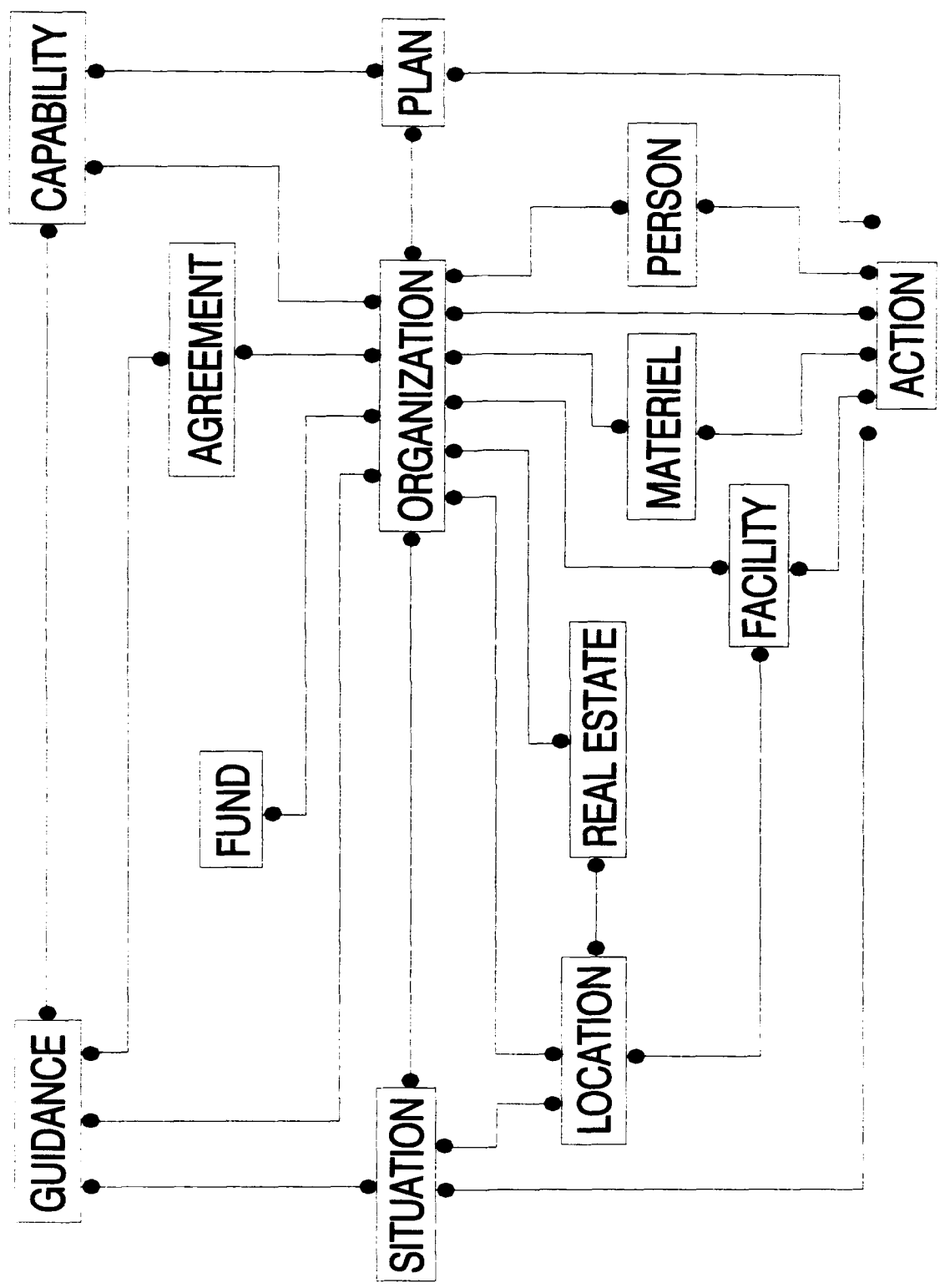

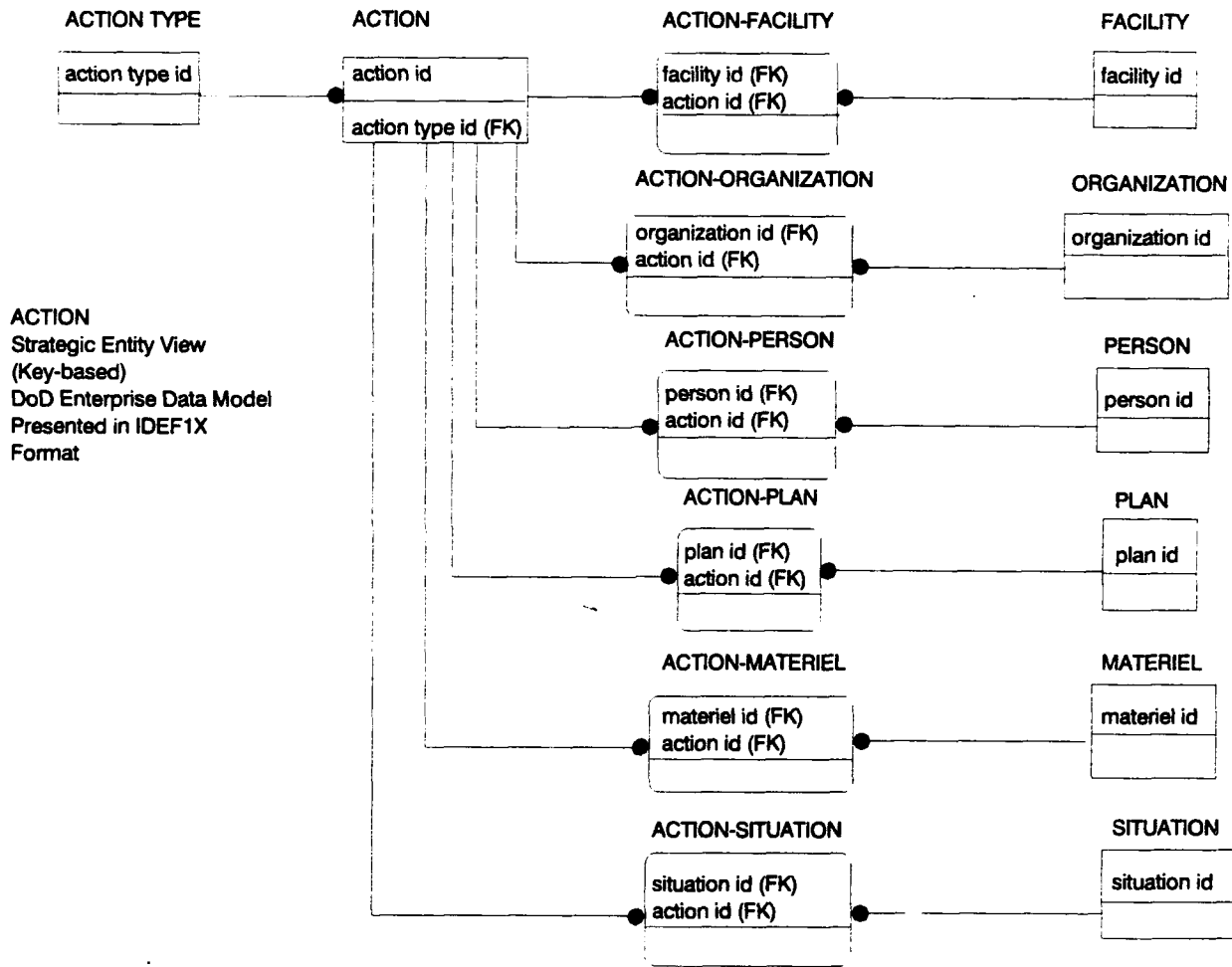

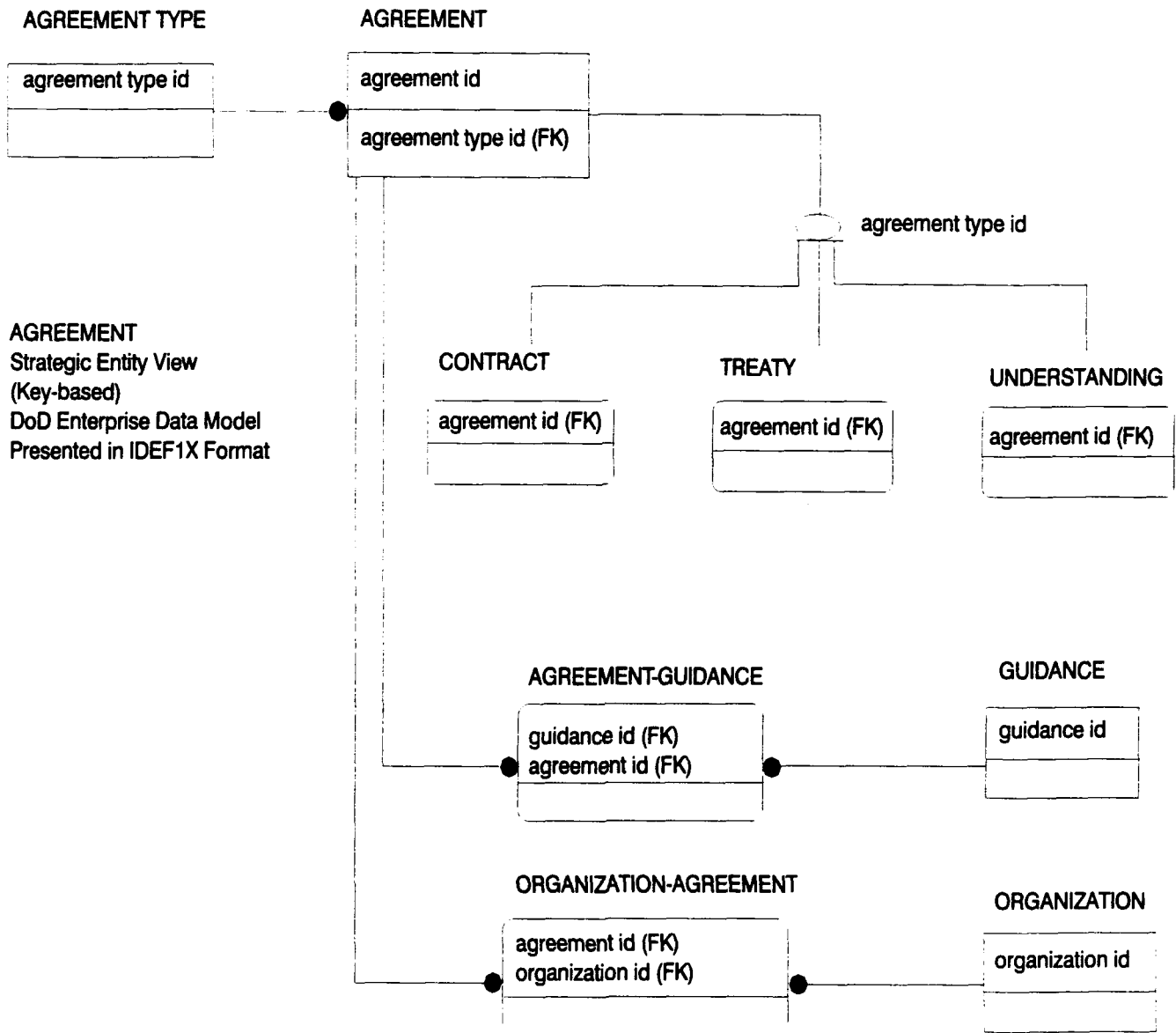

AGREEMENT  
Strategic Entity View  
(Key-based)  
DoD Enterprise Data Model  
Presented in IDEF1X Format

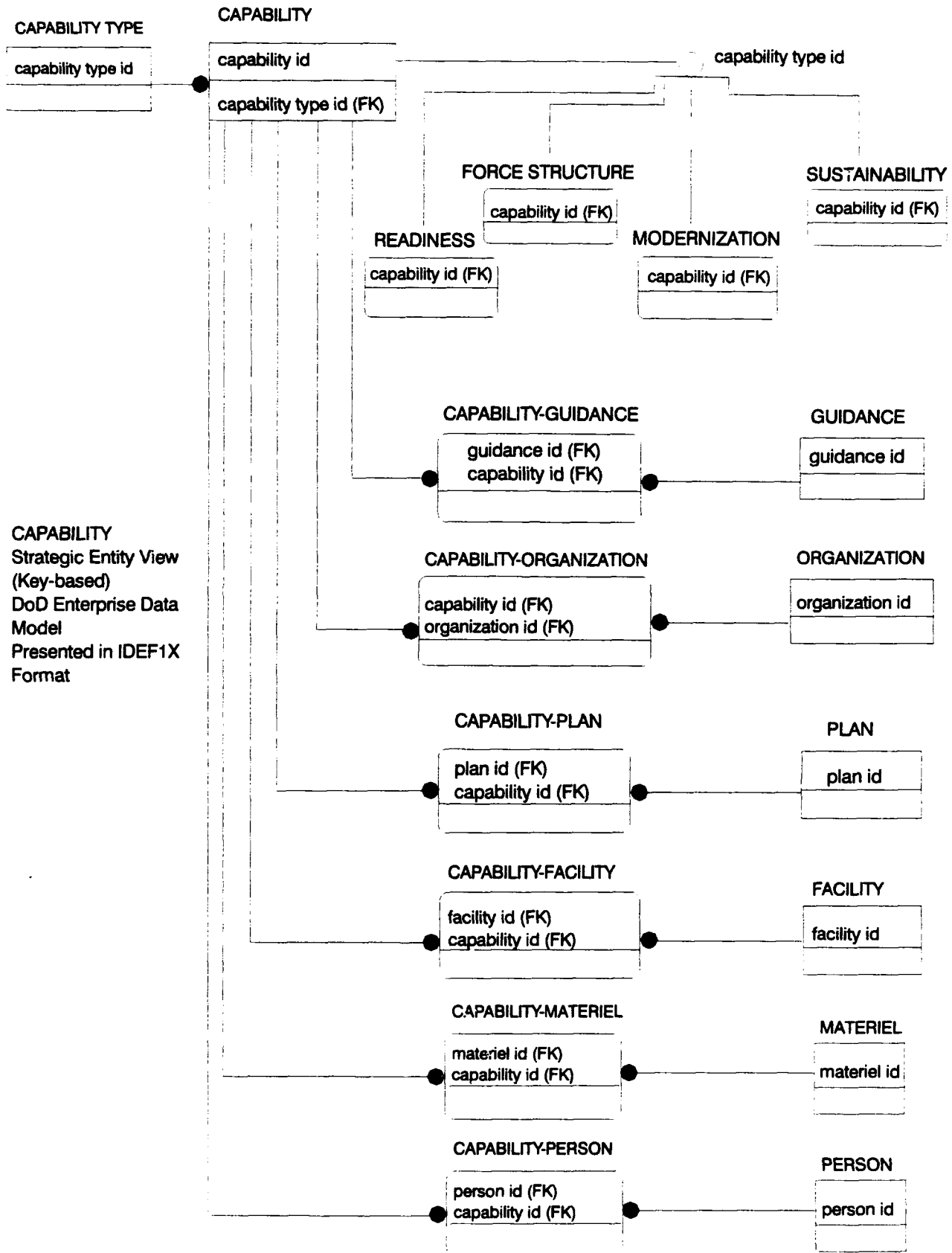

CAPABILITY  
Strategic Entity View  
(Key-based)  
DoD Enterprise Data  
Model  
Presented in IDEF1X  
Format

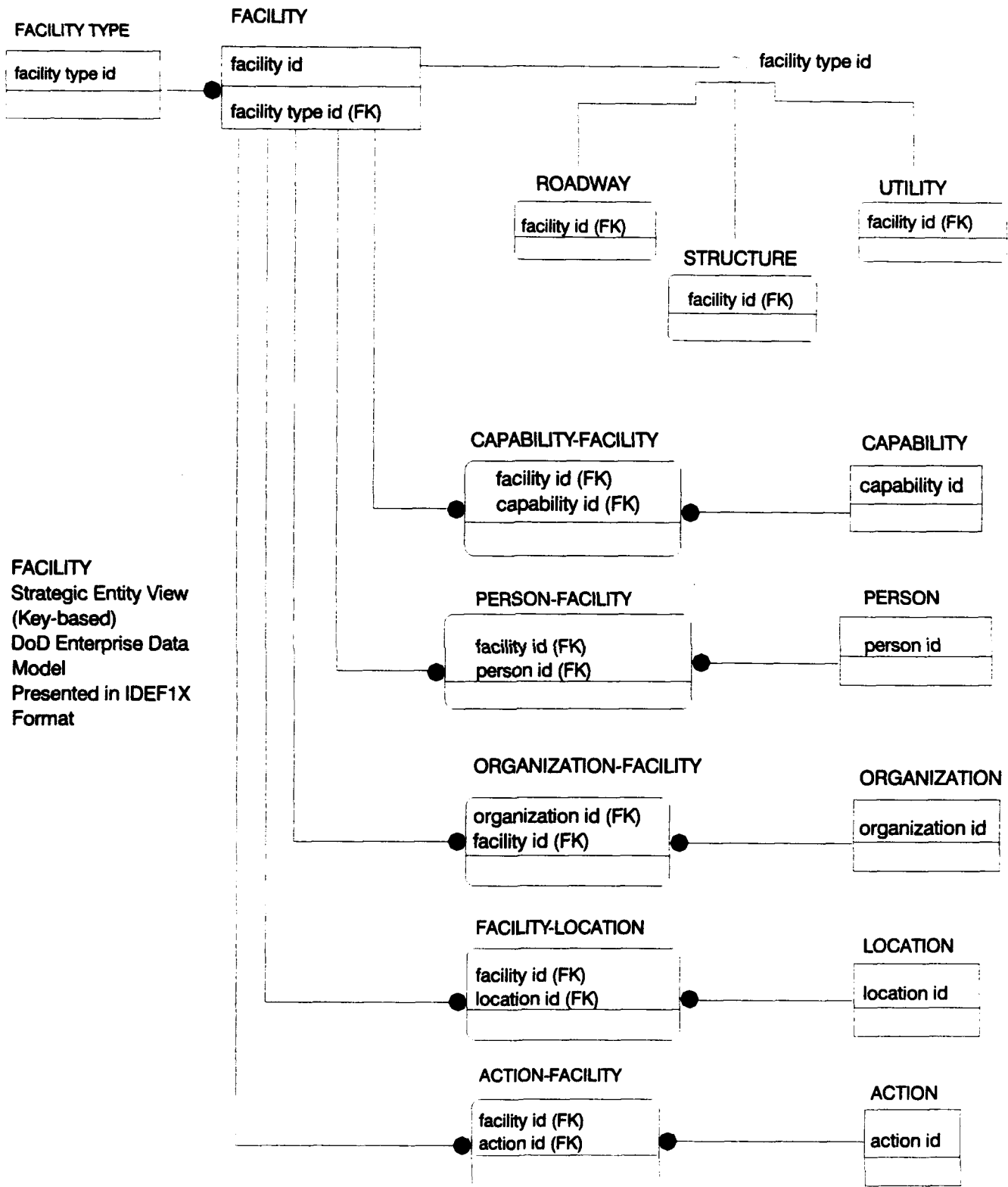

FACILITY  
Strategic Entity View  
(Key-based)  
DoD Enterprise Data  
Model  
Presented in IDEF1X  
Format

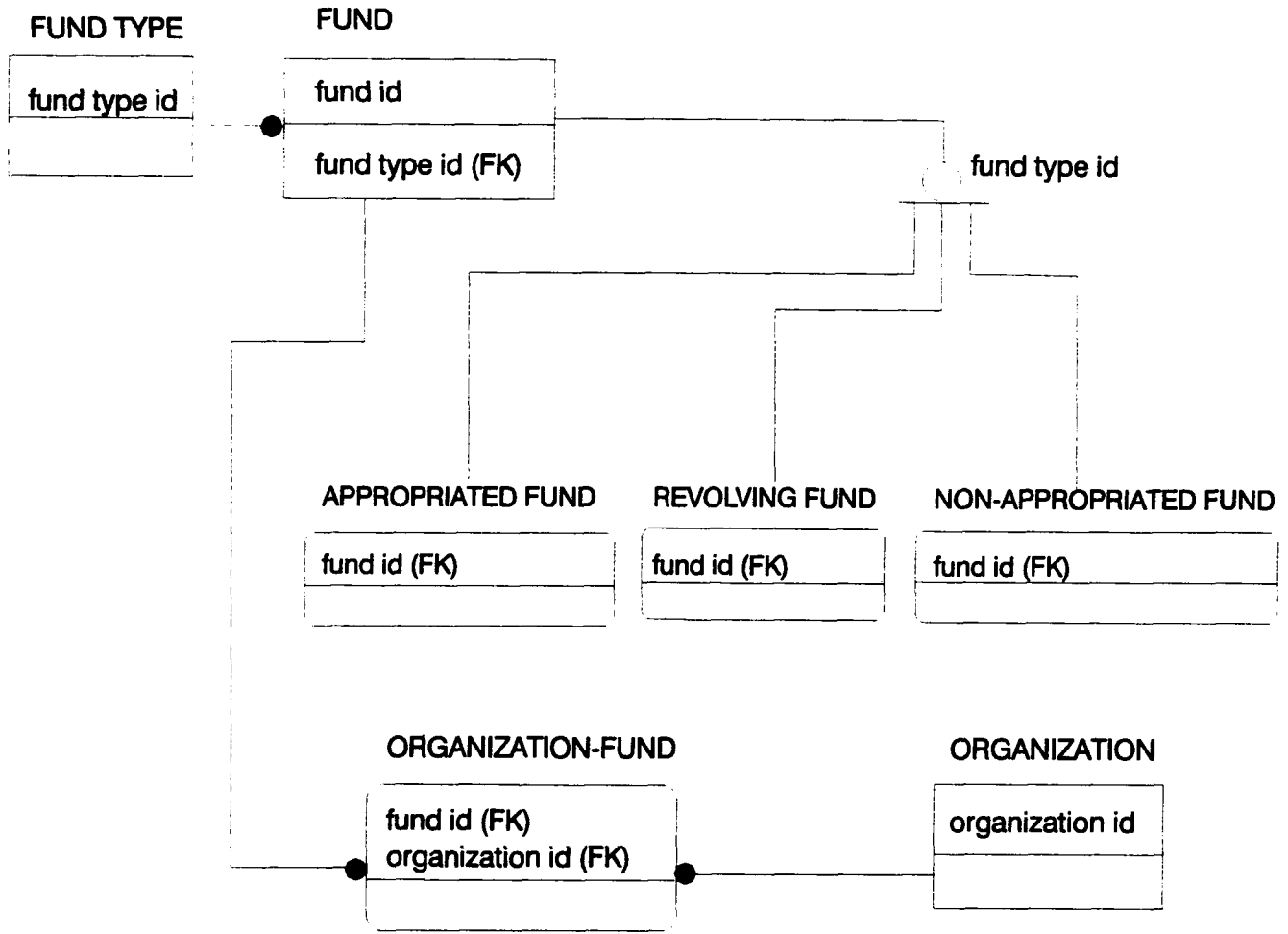

**FUND**  
 Strategic Entity View  
 (Key-based)  
 DoD Enterprise Data Model  
 Presented in IDEF1X Format

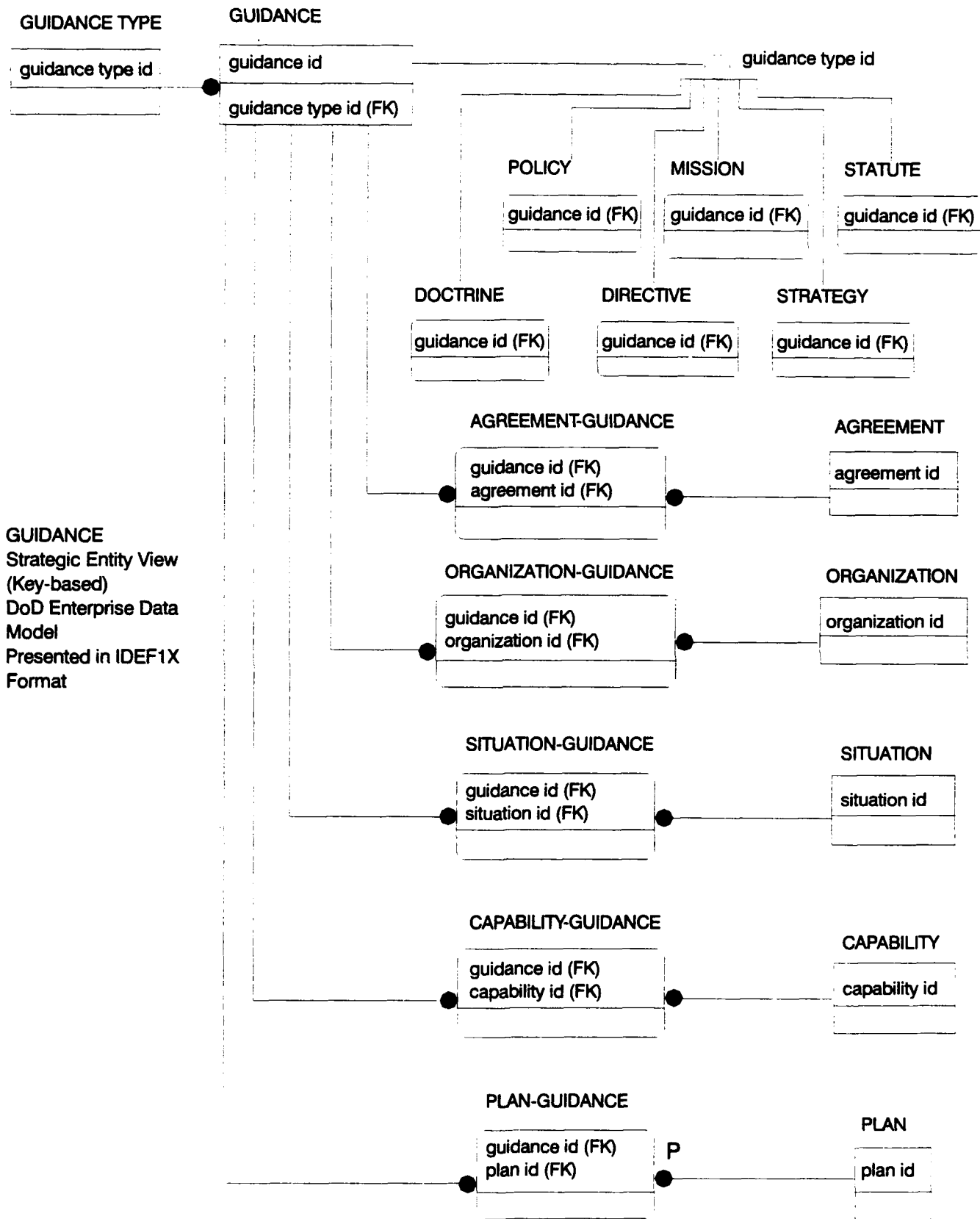

GUIDANCE  
Strategic Entity View  
(Key-based)  
DoD Enterprise Data  
Model  
Presented in IDEF1X  
Format

LOCATION TYPE

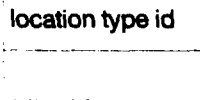

LOCATION

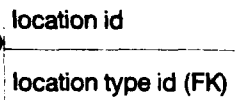

GEOLOCATION



POINT



ADDRESS



FACILITY-LOCATION

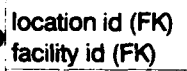

FACILITY



SITUATION-LOCATION

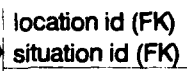

SITUATION



ORGANIZATION-LOCATION

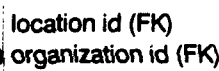

ORGANIZATION



REAL ESTATE-LOCATION

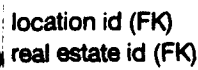

REAL ESTATE



MATERIEL-LOCATION



MATERIEL



PERSON-LOCATION

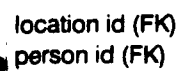

PERSON



LOCATION  
Strategic Entity View  
(Key-based)  
DoD Enterprise Data Model  
Presented in IDEF1X Format

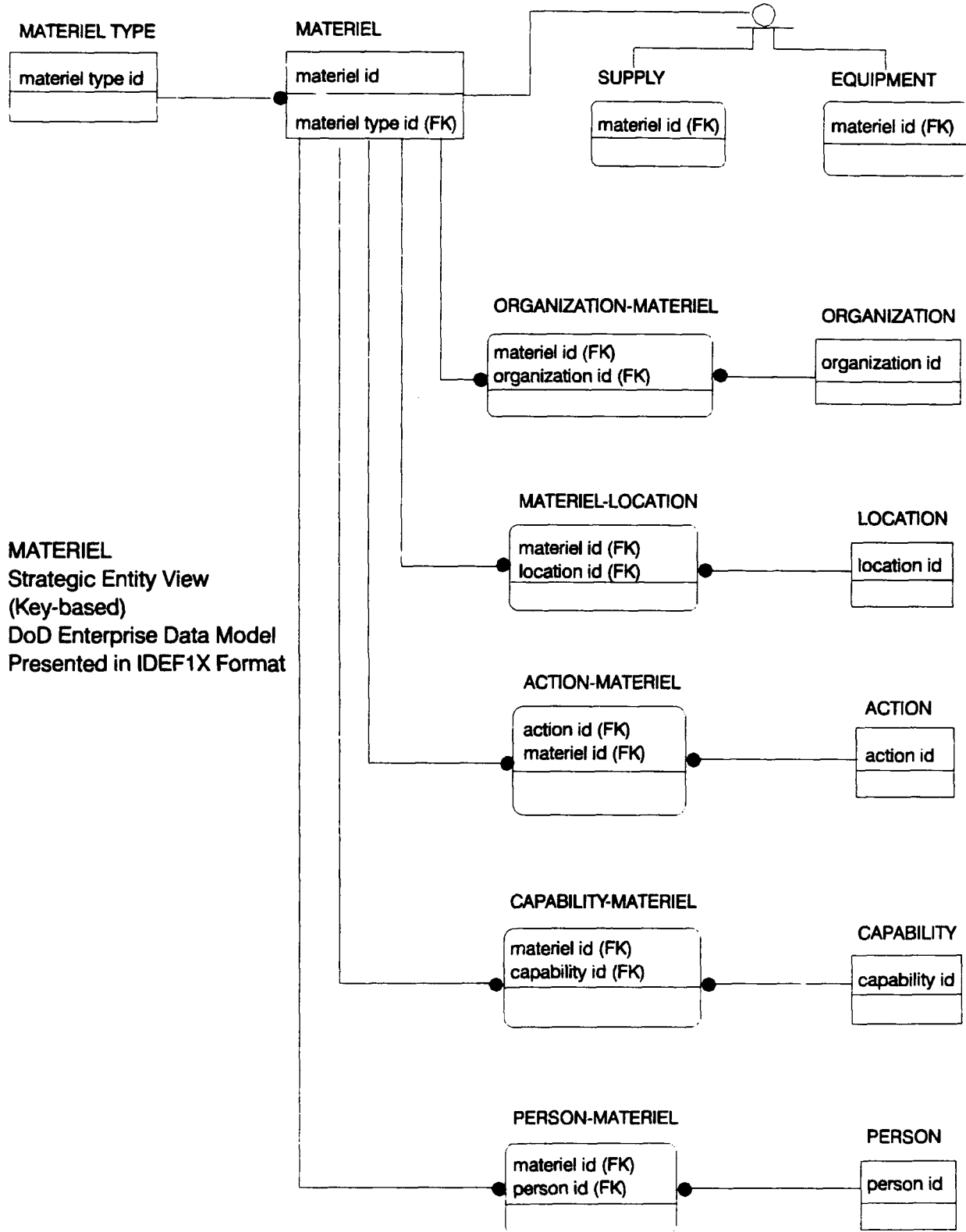

MATERIEL  
Strategic Entity View  
(Key-based)  
DoD Enterprise Data Model  
Presented in IDEF1X Format

ORGANIZATION  
 Strategic Entity View  
 (Key-based)  
 DoD Enterprise Data Model  
 Presented in IDEF1X Format

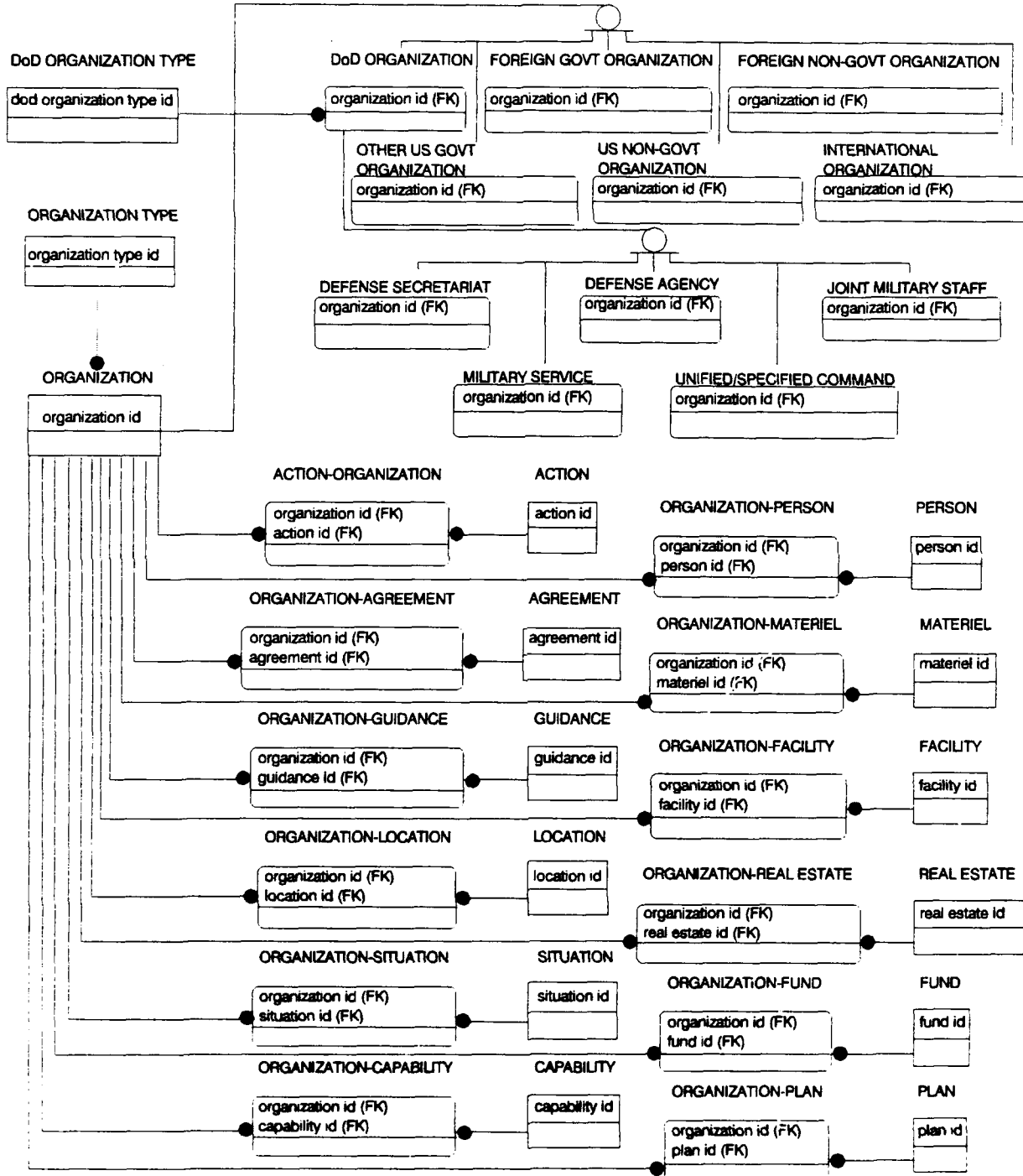

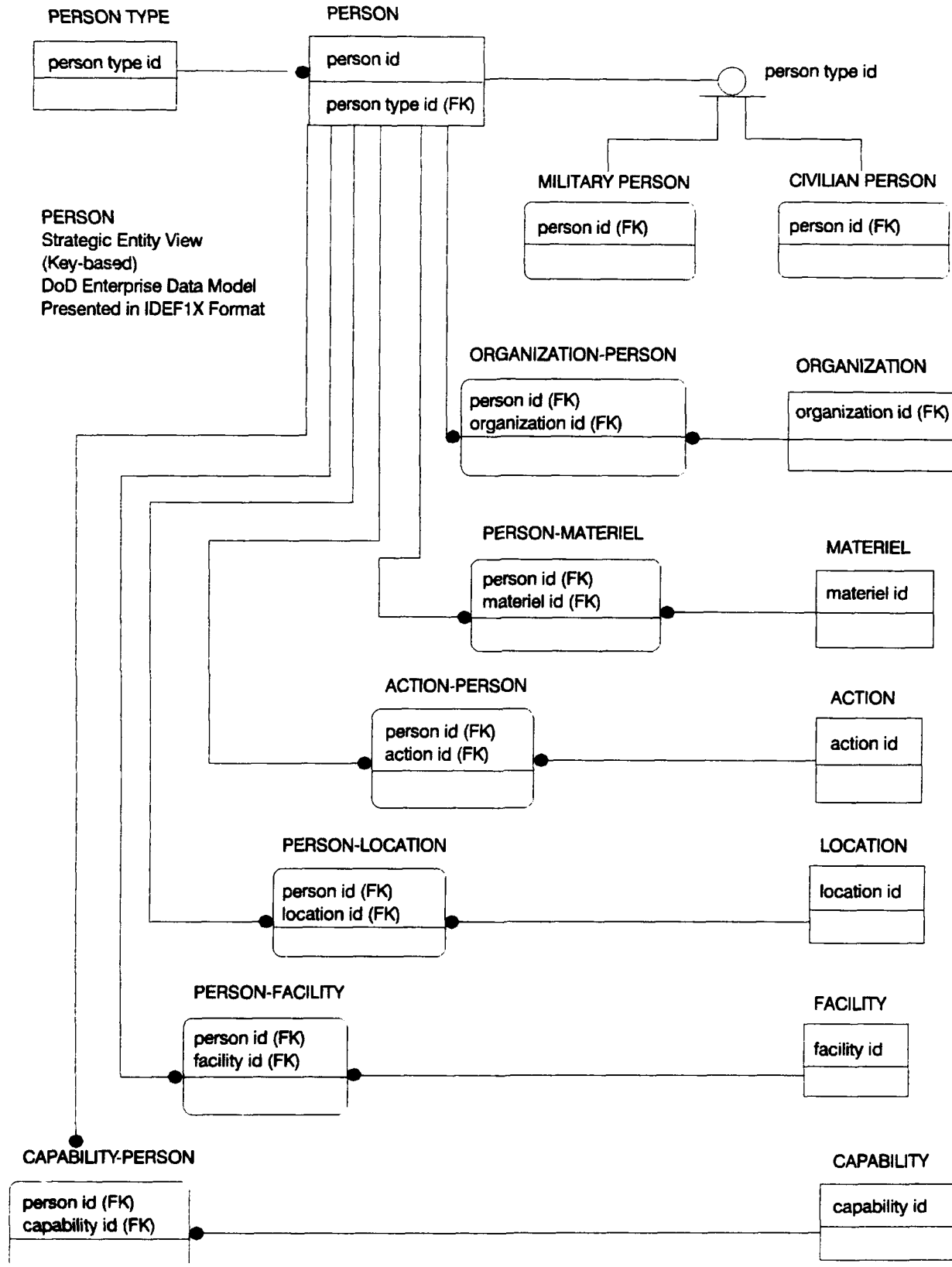

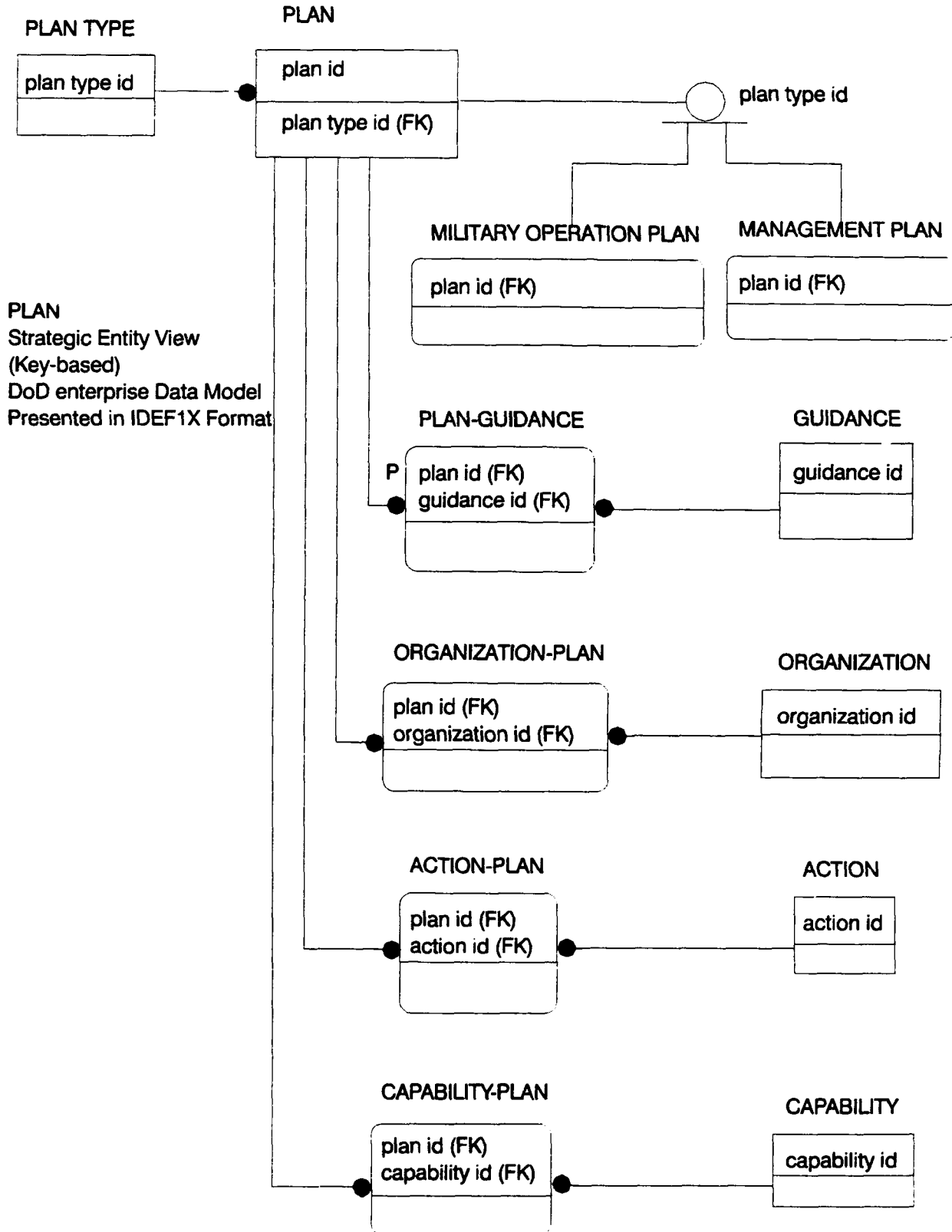

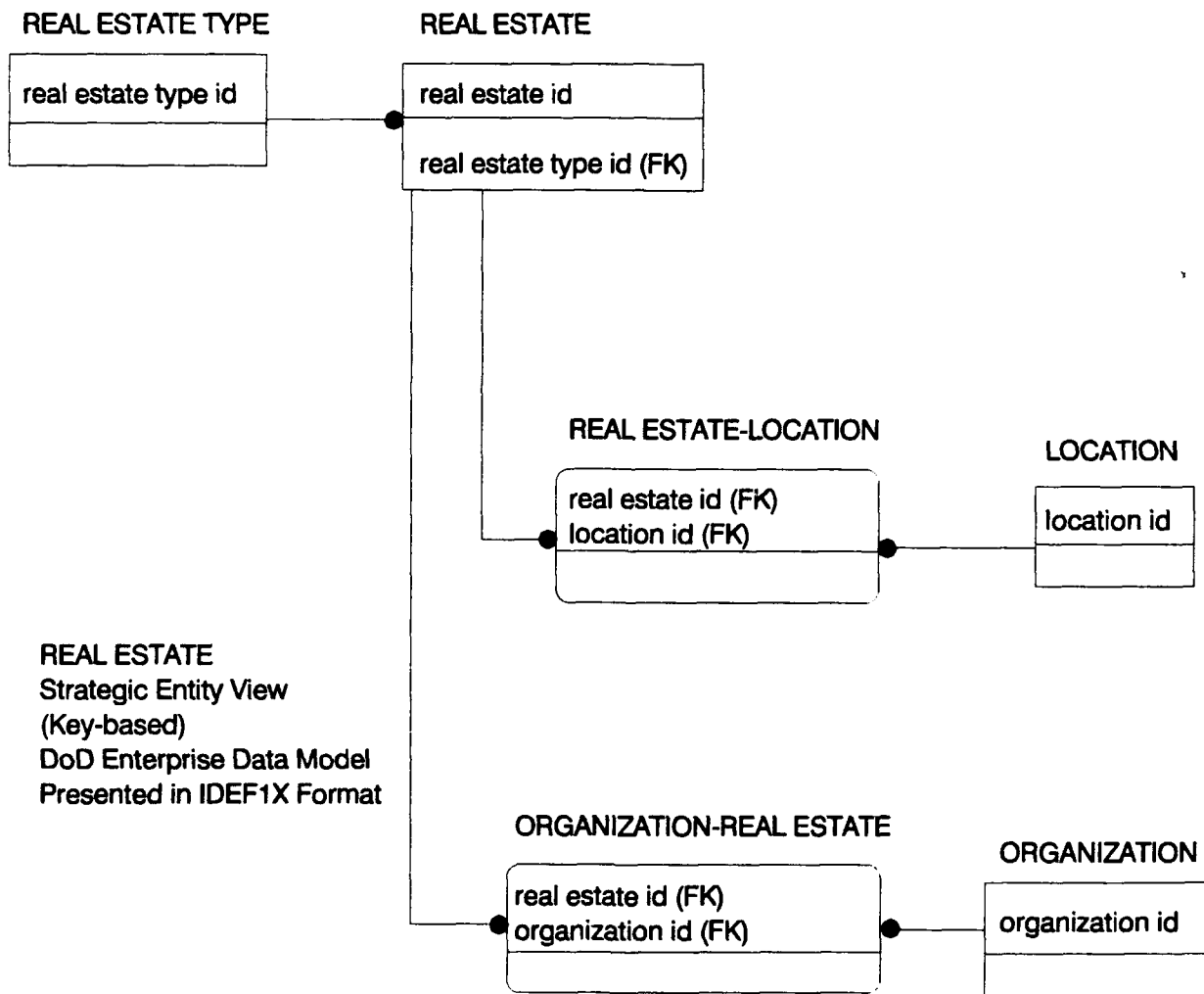

REAL ESTATE  
Strategic Entity View  
(Key-based)  
DoD Enterprise Data Model  
Presented in IDEF1X Format

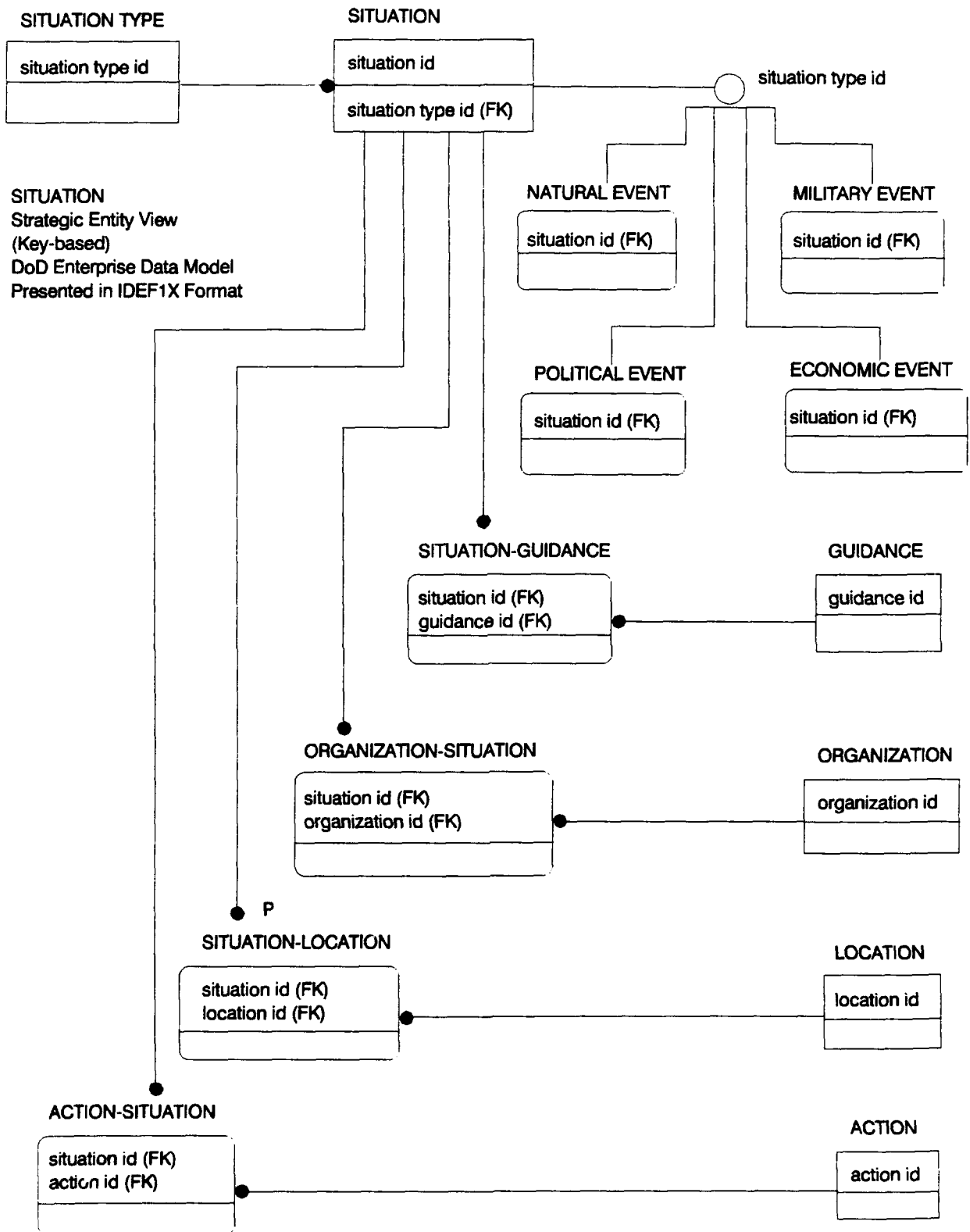

SITUATION  
Strategic Entity View  
(Key-based)  
DoD Enterprise Data Model  
Presented in IDEF1X Format

### **C.3 INTERSECTING ENTITY DESCRIPTIONS**

The strategic level data entity categories shown earlier as "data buckets" in Section 6 are related to each other in a many-to-many fashion, i.e., many items of one "bucket" can be related to many of another. Intersecting entities make it possible to relate each specific item of data captured in one entity with a specific related item of data in another, along with the purpose of each relationship. The actual data representing each data item are generally in a constant state of change; and for purposes of conducting "business" in the Department of Defense, we need to monitor specific items of data in the context of their relationships with other specific items of data and possibly take action if pre-defined conditions or events occur. The ability to do this represents a vital link to "business" activities because a majority of defense "business" activities are heavily involved in tracking multiple items of data. This requires the use of the data tracking and association function facilitated by the intersecting entity of a data model.

Keeping track of specific items of data and the purposes of their relationships with other specific items makes it possible to develop information, and ultimately through continuous audit and analysis to formulate knowledge. Furthermore, this capability is the key to more effective and efficient use of the Department's forces and assets.

From a data model development perspective, intersecting entities are required as the first step to additional detail in the model. The following descriptions illustrate the business purposes supported by three intersecting entities at the strategic level of the DoD Data Model.

**Intersecting Entity: AGREEMENT - GUIDANCE**

**Purpose:** AGREEMENTs will be established and monitored according to the GUIDANCE used to set the conditions and terms of the AGREEMENTs. GUIDANCE will conform to the terms of existing AGREEMENTs and may identify the requirement for new AGREEMENTs or changes to existing AGREEMENTs. Availability of host-nation support established through treaties and AGREEMENTs (e.g., NATO, SEATO) must be part of the integrated PLANning, requirements, and policy GUIDANCE process for each scenario. For example, support needs may be fulfilled through programmed US CAPABILITY(ies), mobilization of US assets, or specific AGREEMENTs with other nations. National security policy GUIDANCE must identify the needs for and the boundaries of international AGREEMENTs, emergency authorities, and political-military constraints. *The National Security Strategy of the United States* and the National Security Decision Directives are the top level GUIDANCE that emerge from this activity. The defense leadership must respond to national security GUIDANCE by developing recommended defense GUIDANCE through global and regional military objectives; by preparing, assessing and recommending strategic military options; by identifying major missions for the DoD; and by recommending GUIDANCE on required host-nation support AGREEMENTs. Subordinate elements of the Department must issue GUIDANCE for their areas of responsibility.

**Attributes:** guidance id #  
agreement id #

**Associations:**

- AGREEMENT  
Purpose: Each AGREEMENT requires specific GUIDANCE that implements the conditions and terms of the AGREEMENT.
  
- GUIDANCE  
Purpose: GUIDANCE is provided to establish the conditions and terms of new or modifications to existing AGREEMENTs.

**Intersecting Entity: ORGANIZATION - FUND**

**Purpose:** Each ORGANIZATION is responsible to identify and acquire the financial resources (FUNDS) necessary to acquire other categories of assets to accomplish its assigned responsibilities (missions) as identified in its PLANS and programs. The acquisition of FUNDS (through budget processes) is necessary in order to acquire other types of assets. FUND acquisition involves the detailed reconciliation of one or more ORGANIZATION requirements to include the assessment of available goods and services, acquisition of technology and developmental items, purchasing, manufacturing, integrating and testing, and any preparation necessary to ensure delivery of a usable asset through the asset distribution systems (e.g., personnel, equipment). FUNDS must be assigned to units and ORGANIZATIONs in accordance with peacetime and mobilization authorization/ distribution PLANS. Departmental-level asset managers will interact with subordinate elements to ensure optimum FUND assignments within available constraints and replenishment capabilities. For FUNDS, this must be accomplished through the mechanisms of command operating budgets, funds authorization, and execution reporting. FUNDS may be assigned to ORGANIZATIONs such as active or reserve units or to inactive status (e.g., Individual Ready Reserve, standby, or retirees for personnel) or earmarked for positioning or separation activities.

**Attributes:** fund id #  
organization id #

**Associations:**

- ——— FUND  
Purpose: A FUND provides the means for one or more ORGANIZATIONs to acquire, maintain, and develop physical assets and personnel and to assess and provide its programmed CAPABILITY(ies).

- ——— ORGANIZATION  
Purpose: An ORGANIZATION utilizes FUNDS to acquire, maintain, and develop physical assets and personnel and to assess and provide its programmed CAPABILITY(ies).

**Intersecting Entity: ORGANIZATION - LOCATION**

**Purpose:** ORGANIZATIONs have responsibilities for activities and assets positioned at LOCATIONs in their areas of responsibility in anticipation of, or response to, SITUATIONs. Considering the assessments of the SITUATIONs (world, regional, and local), PLANs and programs will designate ORGANIZATION and asset LOCATIONs. The status and LOCATION of US ORGANIZATIONs (including forces) and resources must be constantly monitored to provide the NCA and military commanders with a reliable, timely understanding of US CAPABILITY(ies), as well as to comply with Congressional reporting requirements and the GUIDANCE of Public Law. Status reporting may be increased, as necessary, in crisis and war. Global weather, terrain, and oceanographic conditions of many LOCATIONs must be continuously tracked to support ORGANIZATION's operations at current and potential LOCATIONs. Based on ORGANIZATION monitoring activities, GUIDANCE may require ORGANIZATIONs to reposition themselves or some of their assets to new LOCATIONs. PLANs and programs control the distribution and LOCATION of all assets within the Department to ORGANIZATIONs, units, or to specific inventories. PERSONnel, MATERIEL, FUNDS, FACILITY(ies), and REAL ESTATE assets are assigned to units and ORGANIZATIONs in accordance with peacetime and mobilization authorization/distribution PLANs.

**Attributes:** location id #  
organization id #

**Associations:** ●——— LOCATION  
Purpose: A LOCATION involved with one or more SITUATIONs will require ORGANIZATION response with the necessary assets in the appropriate state of readiness.

●——— ORGANIZATION  
Purpose: An ORGANIZATION will be responsible for activities in particular LOCATIONs and maintaining their assets in the state of readiness dictated by the prevailing and emerging SITUATIONs.

## **C.4 USING THE DOD STRATEGIC DATA MODEL TO RECONCILE OR DEVELOP FUNCTIONAL AREA DATA MODELS**

The following functional area data models illustrate the use of the DoD Strategic Data Model. Four functional area views are described below to provide examples of how the Strategic Data Model is to be used in support of model integration. The functional views illustrate the corporate view of the functional requirements and make use of the DoD Strategic Data Model in functional area modeling/reconciliation efforts. Each of the functional area views are provided to demonstrate the links between functional area modeling efforts and the DoD Strategic Data Model.<sup>5/</sup>

### **C.4.1 Using the DoD Strategic Data Model: CAPABILITY-NORM**

The functional view illustrated in Figure C-7 demonstrates the use of four entities described in the DoD Strategic Data Model and the addition of relationships to support the requirement to capture information on the standard capabilities of ORGANIZATIONs, MATERIEL, and FACILITYs.

The idea of normative capabilities for ORGANIZATIONs, MATERIEL, and FACILITYs is captured through the use of three intersecting entities: ORGANIZATION-TYPE-CAPABILITY-NORM, MATERIEL-TYPE-CAPABILITY-NORM, and FACILITY-TYPE-CAPABILITY-NORM. These additional entities, and the attributes assigned, are of interest to the functional area but are not shown in the DoD Strategic Data Model.

The following instance tables demonstrate the use of the CAPABILITY entity and the capability norm entities. Table C-1 illustrates the use of the entity CAPABILITY in this context. As shown, capabilities are described and a unit of measure is assigned to each capability. For example, capability number one (1) is "move earth" and is measured in tons per hour. Another capability is "time into action" (applicable to an artillery unit) which is measured in minutes.

---

<sup>5/</sup> The functional area views presented are for illustration only. None of the views described in this section have been validated or approved cross functionally in accordance with DoD 8320.1 series guidance.

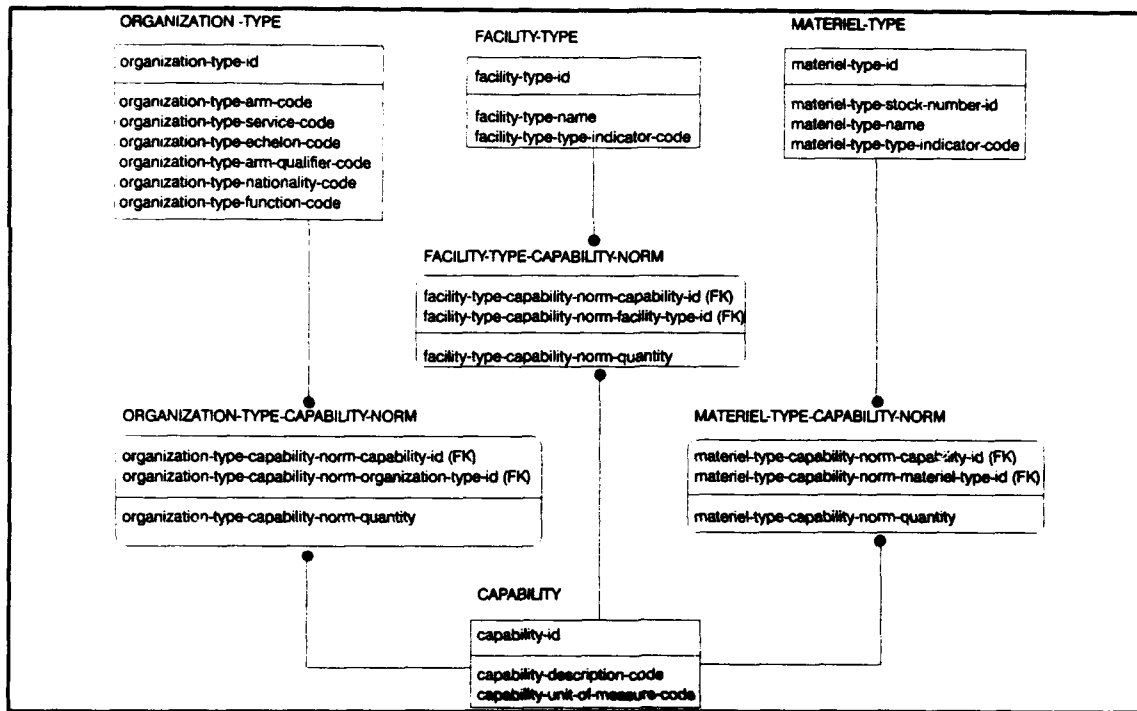

Figure C-7. CAPABILITY-NORM

capability-id	capability-description-text	capability-unit-of-measure-text
1	move earth	tons per hour
2	time into action	minutes
3	move people	persons
4	standard pallet load capacity	standard pallets

Table C-1. CAPABILITY INSTANCE TABLE

## CAPABILITY

Table C-2 illustrates how the ORGANIZATION-TYPE-CAPABILITY-NORM entity is used to record the normative capabilities of various types of organizations. For example, the following semantic sentences can be constructed from the information held under the entities:

- a. The UK Field Engineer Troop is normally able to move 300 tons of earth per hour.
- b. A UK Artillery Battery equipped with ABBOT 105-mm self-propelled (SP) guns has a normal time into action of 1 minute.
- c. A US Transportation Company equipped with 8-ton flat-bed trucks can normally carry 250 persons or 60 standard pallets.
- d. A US Field Artillery Battery equipped with 105-mm light guns has a normal time into action of 3 minutes.

**ORGANIZATION-TYPE-CAPABILITY-NORM**

capability-id	organization-type-id	capability-norm-quantity
1 (move earth)	org-type-id 27 (UK Field Engr Troop equipped with CET) <sup>6/</sup>	300
2 (time into action)	org-type-id 25 (UK Arty Bty equipped with ABBOT 105-mm SP Guns) <sup>7/</sup>	1
3 (move people)	org-type-id 33 (US Trans Co equipped with 8-ton Flat bed trucks)	250
4 (standard pallet load capacity)	org-type-id 33 (US Trans Co equipped with 8-ton Flat bed trucks)	60
2 (time into action)	org-type-id 29 (US Field Arty Bty equipped with 105-mm Lt Guns) <sup>8/</sup>	3

Table C-2. CAPABILITY-NORM EXAMPLE

<sup>6/</sup> CET-Combat Engineer Tractor (a UK-manufactured vehicle in service).

<sup>7/</sup> The ABBOT 105-mm SP is a self-propelled armored 105-mm Artillery Gun currently in use in several NATO armies.

<sup>8/</sup> The 105-mm Lt Gun is a UK-manufactured light field gun currently in use in the UK Parachute and Commando Forces and with elements of the USMC.

### C.4.2 Using the DoD Strategic Data Model: DOCUMENT

The functional view shown in Figure C-8 demonstrates the use of three entities described in the DoD Strategic Data Model (PLAN, GUIDANCE, and AGREEMENT). Additional entities of interest to the functional area include: one independent entity (DOCUMENT) and eight dependent entities (DOCUMENT-MEDIA, DOCUMENT-ASSOCIATION, FORMATED OUTPUT-SPECIFICATION, DOCUMENT-TYPE-DEFINITION, PLAN-DOCUMENT, GUIDANCE-DOCUMENT, CONTRACT-DOCUMENT, and DRAWING).

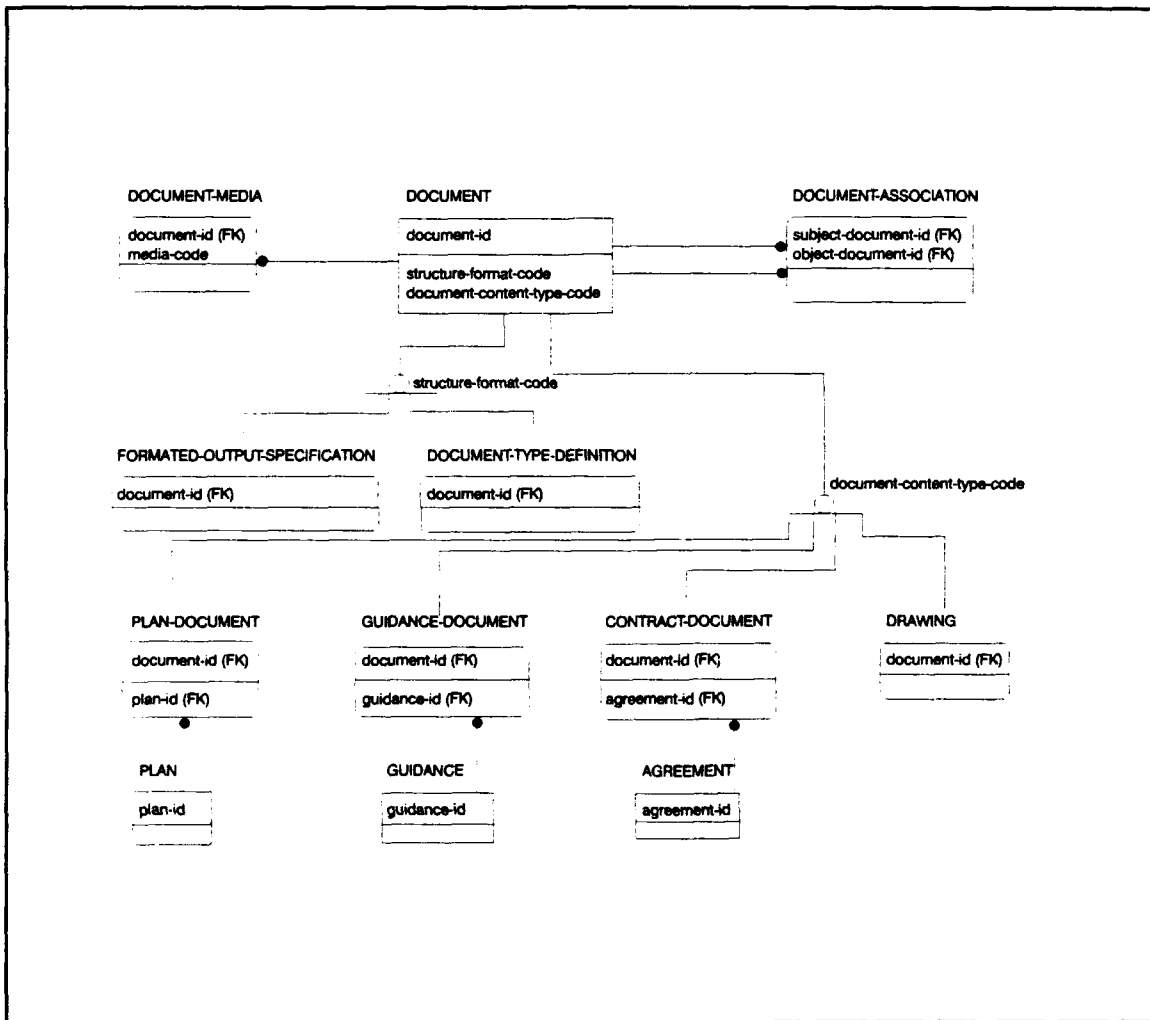

Figure C-8. DOCUMENT

Functionally, this view shows two types of separations that are important to the management of information within the functional area. First, there is a separation between information about a DOCUMENT (i.e., data stored under DOCUMENT and DOCUMENT-MEDIA) and the structure and format of a DOCUMENT (i.e., data stored under the entities FORMATED-OUTPUT-SPECIFICATION and DOCUMENT-TYPE-DEFINITION). Second, there is a separation between information about a specific type of DOCUMENT (e.g., PLAN-DOCUMENT, GUIDANCE-DOCUMENT) and the content information which is stored under the DoD Strategic Data Model entities PLAN, GUIDANCE, and AGREEMENT. Generally, content information is included in a DOCUMENT. In addition, each DOCUMENT has a specific structure and format which controls the associations between the parts of a DOCUMENT (i.e., DOCUMENT-ASSOCIATION).

#### **C.4.3 Using the DoD Strategic Data Model: LOCATION**

Figure C-9 uses entities described in the DoD Strategic Data Model in a functional view of the associations between LOCATION and FACILITY, MATERIEL, ORGANIZATION, PERSON, and a functional level entity FEATURE. The preceding five entities represent primary battlefield objects on which location information is required to be maintained.

Data on relationships is captured by the intersecting entities FACILITY-LOCATION, MATERIEL-LOCATION, ORGANIZATION-LOCATION, PERSON-LOCATION, and FEATURE-LOCATION. The intersecting entities provide the means to record the battlefield object's position and status over time. Also note the category entity structure under LOCATION which provides a robust means of identifying a battlefield object's position relative to a point, line, area, or volume.

#### **C.4.4 Using the DoD Strategic Data Model: FEATURE**

The functional view shown in Figure C-10 demonstrates the use of two entities described in the DoD Strategic Data Model (FACILITY and LOCATION) and the addition of four entities of interest to the functional area: one (1) independent entity (FEATURE) and three (3) dependent entities (GEOGRAPHIC-FEATURE, MET-FEATURE (meteorological feature), and CONTROL-FEATURE).

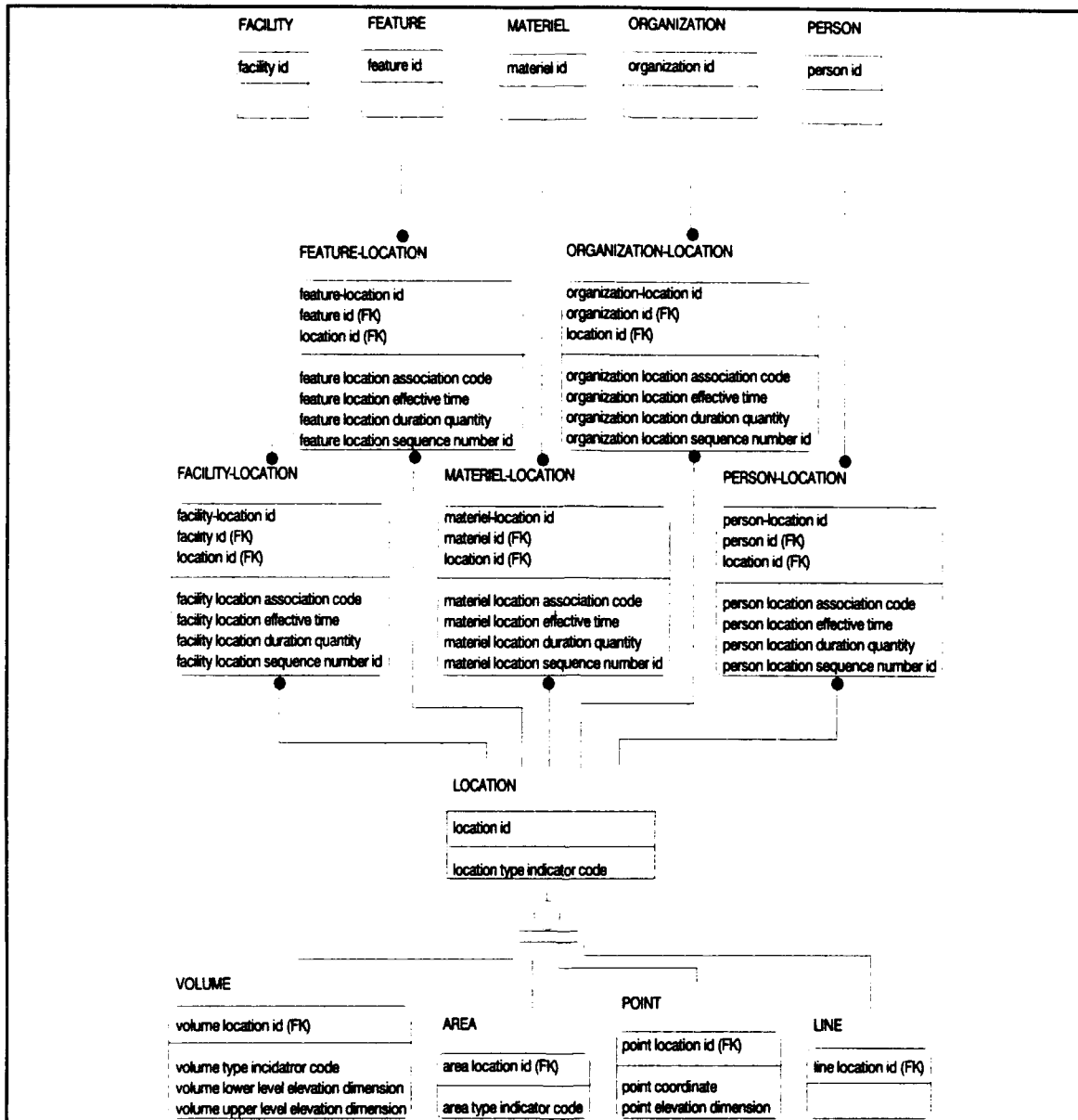

Figure C-9. LOCATION

The functional view concerning FEATURE illustrates a number of points that are of interest. First, entity names or labels can be both essential and misleading. For example, without an appropriate definition of FEATURE, one could be lead to conclude that the data need has something to do with features as in movies, faces, or athletic events.

Second, even though the definitions of FEATURE, GEOGRAPHIC-FEATURE, MET-FEATURE, and CONTROL-FEATURE (shown below) are helpful in understanding the data requirement, attribution of the entities reveals significant detail about the information stored under each entity. Third, the relationships to existing strategic entities provide a richer context in which to understand the functional area data requirements.

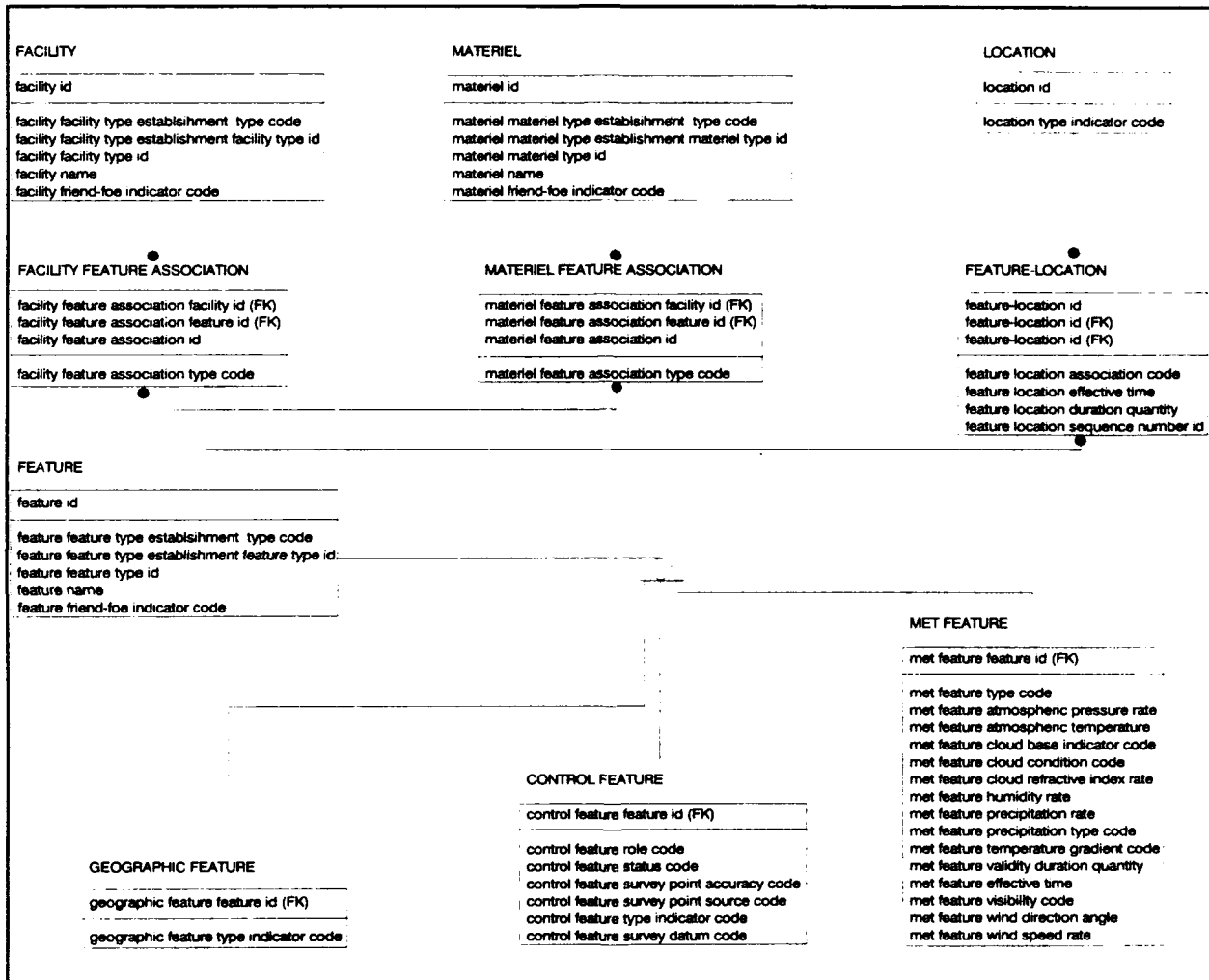

Figure C-10. FEATURE

- a. **FEATURE**: A set of characteristics, phenomena, or structures relative to the earth's surface.
- b. **GEOGRAPHIC-FEATURE**: A class of characteristics relating to a location, to which military significance is attached (Derived from Digital

Geographic Information Exchange Standard (DIGEST)). In cartography, a feature is any object or configuration of ground or water represented on the face of a map or chart.

- c. **MET-FEATURE:** A condition pertaining to the atmosphere, such as wind, temperature, air density, and other phenomena, associated to a geographic location and to which military significance is attached.
- d. **CONTROL-FEATURE:** Characteristics of military interest that may be represented by a point(s), line(s), area(s), or volume(s), which are associated with the conduct of military operations and which are located by one or a number of points.

Generally, the functional view concerning FEATURE demonstrates that in linking a functional view to the DoD Strategic Data Model, attention must be given to entity names, entity definitions, attribute names, attribute definitions, the relationships between the entities that are supported, and the metadata that describes the attributes. Given this information, functional area modelers can determine how their functional area models can be integrated with the DoD Strategic Data Model. As illustrated, functional area models can be integrated at many levels. The DoD Strategic Data Model provides the single starting point for data integration across the Department.

*THIS PAGE INTENTIONALLY  
LEFT BLANK*

**APPENDIX D**  
**DATA MODEL GLOSSARY**

**APPENDIX D**  
**DoD STRATEGIC DATA MODEL GLOSSARY**

---

**DATA ENTITY GLOSSARY**

**APPENDIX D**  
**DoD STRATEGIC DATA MODEL GLOSSARY**

---

**ACTION**

An activity.

**ACTION-FACILITY**

Indicates that an ACTION may be associated with zero, one, or many FACILITYs and that an occurrence of FACILITY may be associated with zero, one, or many ACTIONs. FACILITYs may be a resource, or an objective of an ACTION.

**ACTION-MATERIEL**

Indicates that an ACTION may be associated with zero, one, or many instances of MATERIEL and that an occurrence of MATERIEL may be associated with zero, one, or many ACTIONs. ACTIONs may require MATERIEL in order to occur or MATERIEL may be the objective of an ACTION.

**ACTION-ORGANIZATION**

Indicates that an ACTION may be associated with zero, one, or many instances of ORGANIZATION and that an occurrence of ORGANIZATION may be associated with zero, one, or many ACTIONs. ORGANIZATIONs may be the executor or objective of an ACTION.

**ACTION-PERSON**

Indicates that an ACTION may be associated with zero, one, or many instances of PERSON and that an occurrence of PERSON may be associated with zero, one, or many ACTIONs. PERSONs may be the executor or objective of an ACTION.

**APPENDIX D**  
**DoD STRATEGIC DATA MODEL GLOSSARY**

---

**ACTION-PLAN**

Indicates that an ACTION may be associated with zero, one, or many instances of PLAN and that an occurrence of PLAN may be associated with zero, one, or many ACTIONS. PLANS contain and are related to an ACTION or a series of ACTIONS.

**ACTION-SITUATION**

Indicates that an ACTION may be associated with zero, one, or many instances of SITUATION and that an occurrence of SITUATION may be associated with zero, one, or many ACTIONS. SITUATIONS may be caused, or based on ACTIONS, or ACTIONS may result from SITUATIONS.

**ACTION-TYPE**

The specification of a particular activity category.

**ADDRESS**

A place or position defined by indication of destination, as on mail or parcels (e.g., street or rural route number, city, state, and ZIP code).

**AGREEMENT**

An arrangement between parties.

**AGREEMENT-GUIDANCE**

Indicates that an AGREEMENT may be associated with zero, one, or many occurrences of GUIDANCE and that an occurrence of GUIDANCE may be associated with zero, one, or many AGREEMENTS. AGREEMENTS may be required as a result of changes in GUIDANCE or GUIDANCE may be influenced by existing AGREEMENTS.

**APPENDIX D**  
**DoD STRATEGIC DATA MODEL GLOSSARY**

---

**AGREEMENT TYPE**

The specification of a particular accord category.

**APPROPRIATED FUND**

A fund stemming from legislative action with designation for a specific use or purpose.

**CAPABILITY**

An ability to achieve an objective.

**CAPABILITY-FACILITY**

Indicates that a **CAPABILITY** may be associated with zero, one, or many occurrences of **FACILITY** and that an occurrence of **FACILITY** may be associated with zero, one, or many **CAPABILITYs**. **FACILITYs** have and provide **CAPABILITY**.

**CAPABILITY-GUIDANCE**

Indicates that a **CAPABILITY** may be associated with zero, one, or many occurrences of **GUIDANCE** and that **GUIDANCE** may be associated with zero, one, or many **CAPABILITYs**. Evaluations are made to determine if **CAPABILITYs** are sufficient with respect to consideration of national security and recommendations (**GUIDANCE**) are made for improvement. **Taskings (GUIDANCE)** are promulgated to integrate the **CAPABILITYs** of forces.

**CAPABILITY-MATERIEL**

Indicates that a **CAPABILITY** may be associated with zero, one, or many occurrences of **MATERIEL** and that an occurrence of **MATERIEL** may be associated with zero, one, or many **CAPABILITYs**. Each instance of **MATERIEL** has **CAPABILITY**.

---

**APPENDIX D**  
**DoD STRATEGIC DATA MODEL GLOSSARY**

---

**CAPABILITY-PERSON**

Indicates that a CAPABILITY may be associated with zero, one, or many occurrences of PERSON and that an occurrence of PERSON may be associated with zero, one, or many CAPABILITIES. PERSONs have and provide CAPABILITY.

**CAPABILITY-PLAN**

Indicates that a CAPABILITY may be associated with zero, one, or many occurrences of PLAN and a PLAN may be associated with zero, one, or many occurrences of CAPABILITY. A PLAN specifies the CAPABILITY required to achieve an end or a method (PLAN) for achieving the ability (CAPABILITY) to do something over time.

**CAPABILITY-TYPE**

The specification of a particular ability category.

**CIVILIAN PERSON**

A person who is not a member of the armed forces and who is of interest to the Department of Defense.

**CONTRACT**

A legally enforceable agreement between two or more parties for the supply of specified goods or services.

**DEFENSE AGENCY**

An organization within DoD which performs a supply or service activity common to more than one military department.

**APPENDIX D**  
**DoD STRATEGIC DATA MODEL GLOSSARY**

---

**DEFENSE SECRETARIAT**

The DoD organization which includes the Secretary and Deputy Secretary of Defense, Under and Assistant Secretaries, other Principal Staff Assistants and their staffs, and other offices so designated to assist the Secretary of Defense in carrying out his duties and responsibilities.

**DIRECTIVE**

Regulatory guidance.

**DOCTRINE**

A principle.

**DOD ORGANIZATION**

An organization within the Department of Defense (e.g., Office of the Secretary of Defense (OSD), Joint Chiefs of Staff (JCS), Military Services, Defense Agencies).

**DoD ORGANIZATION-TYPE**

The specification of a particular organization category within the Department of Defense.

**ECONOMIC EVENT**

Any action, campaign, or event relating to the development, production, and management of material wealth (matters of finance), as of a country, household, or business enterprise.

**EQUIPMENT**

Material that is not consumed in use, retains its original identity during the period of use, and requires accountability. All non-expendable items needed to outfit/equip an individual or organization.

**APPENDIX D**  
**DoD STRATEGIC DATA MODEL GLOSSARY**

---

**FACILITY**

Physical property, having a specified use, consisting of one or more of the following: a building, a structure, a utility system, and pavement.

**FACILITY-LOCATION**

Indicates that a FACILITY is associated with zero, one, or many occurrences of LOCATION, and that an occurrence of LOCATION may be associated with zero, one, or many FACILITYs. In many cases, the management and administration of a FACILITY requires that the LOCATION of the FACILITY be known. In some instances, planning activities include identifying future LOCATIONs of FACILITYs.

**FACILITY-TYPE**

The specification of a particular facility category.

**FORCE STRUCTURE**

Numbers, size, and composition of the elements that comprise a given capability.

**FOREIGN GOVERNMENT ORGANIZATION**

An organization consisting of any group accepted as representing the interests of the recognized government of a foreign country. This entity includes ministries, diplomatic organizations, military organizations, and delegations.

**FOREIGN NON-GOVERNMENT ORGANIZATION**

An organization that exists outside the US and that is not part of a foreign government.

**APPENDIX D**  
**DoD STRATEGIC DATA MODEL GLOSSARY**

---

**FUND**  
A financial resource established for a purpose.

**FUND-TYPE**  
The specification of a particular financial category.

**GEOLOCATION**  
A place or position defined by geolocation reference.

**GUIDANCE**  
A statement of direction.

**GUIDANCE-TYPE**  
The specification of a particular counsel category.

**INTERNATIONAL ORGANIZATION**

An organization comprised of members from two or more nations, e.g., the North Atlantic Treaty Organization (NATO) or United Nations (UN).

**JOINT MILITARY STAFF**

The DoD organization composed of the Chairman, Joint Chiefs of Staff; the Military Service Chiefs; and the Joint Staff; which provides military advice and support to the President and the Secretary of Defense.

**LOCATION**  
A specific place.

---

**APPENDIX D**  
**DoD STRATEGIC DATA MODEL GLOSSARY**

**LOCATION-TYPE**

The specification of a particular position category.

**MANAGEMENT PLAN**

A plan which is related to an activity other than a military or naval action, campaign, or maneuver.

**MATERIEL**

An object of interest that is non-human, mobile, and physical.

**MATERIEL-LOCATION**

Indicates that a MATERIEL instance is associated with zero, one, or many occurrences of LOCATION, and that an occurrence of LOCATION may be associated with zero, one, or many instances of MATERIEL. In many cases the management and administration of MATERIEL requires that the LOCATION of the MATERIEL be known. In some instances, planning activities include identifying future LOCATIONS of MATERIEL.

**MATERIEL-TYPE**

The specification of a particular materiel category.

**MILITARY EVENT**

Any armed forces action, campaign, event, or maneuver.

**MILITARY PERSON**

A person who is enlisted, warranted, or commissioned in one of the armed forces of the Department of Defense.

**MILITARY OPERATION PLAN**

A plan for a military or naval action, campaign, or maneuver.

---

**APPENDIX D**  
**DoD STRATEGIC DATA MODEL GLOSSARY**

---

**MILITARY SERVICE**

A DoD organization which is a branch of the armed forces of the United States.

**MISSION**

An objective.

**MODERNIZATION**

Technical sophistication of an organization, person, weapon system, or equipment.

**NATURAL EVENT**

An occurrence which is in accordance with or determined by nature (e.g., earthquake, hurricane, volcanic eruption).

**NON-APPROPRIATED FUND**

A fund generated by DoD military and civilian personnel and their dependents and used to augment funds appropriated by the Congress to provide a comprehensive, morale-building, welfare, religious, educational, and recreational program, designed to improve the well-being of military and civilian personnel and their dependents.

**ORGANIZATION**

An administrative structure with a mission.

**ORGANIZATION-AGREEMENT**

Indicates that an ORGANIZATION may be associated with zero, one, or many occurrences of AGREEMENT and that an occurrence of AGREEMENT may be associated with zero, one, or many ORGANIZATIONS. ORGANIZATIONS negotiate, participate in, and abide by AGREEMENTS.

**APPENDIX D**  
**DoD STRATEGIC DATA MODEL GLOSSARY**

---

**ORGANIZATION-CAPABILITY**

Indicates that an ORGANIZATION may be associated with zero, one, or many occurrences of CAPABILITY and that an occurrence of CAPABILITY may be associated with zero, one, or many ORGANIZATIONS. ORGANIZATIONS are designed and formed to provide and project CAPABILITYs. ORGANIZATIONs evaluate their CAPABILITYs and make recommendations for improvement.

**ORGANIZATION-FACILITY**

Indicates that an ORGANIZATION may be associated with zero, one, or many occurrences of FACILITY, and that an occurrence of FACILITY may be associated with zero, one, or many ORGANIZATIONS. ORGANIZATIONS acquire and manage FACILITYs.

**ORGANIZATION-FUND**

Indicates that an ORGANIZATION may be associated with zero, one, or many occurrences of FUND, and that an occurrence of FUND may be associated with zero, one, or many occurrences of ORGANIZATION. ORGANIZATIONs manage and allocate FUNDS to satisfy requirements.

**ORGANIZATION-GUIDANCE**

Indicates that an ORGANIZATION may be associated with zero, one, or many issuances of GUIDANCE and GUIDANCE will be associated with zero, one, or many ORGANIZATIONS. Within assigned areas of responsibility, ORGANIZATIONs issue GUIDANCE. GUIDANCE is received from other ORGANIZATIONS (e.g., from other DoD organizations, from Congress, from the National Command Authority).

**APPENDIX D**  
**DoD STRATEGIC DATA MODEL GLOSSARY**

---

**ORGANIZATION-LOCATION**

Indicates that an ORGANIZATION may be associated with zero, one, or many occurrences of LOCATION and that an occurrence of LOCATION may be associated with zero, one, or many ORGANIZATIONS. An ORGANIZATION may exist on paper and therefore not have a LOCATION; but if staffed and equipped, the ORGANIZATION must have a LOCATION. ORGANIZATIONS execute actions related to designated areas in the world (LOCATIONS) and require space, facilities, and services at LOCATIONS.

**ORGANIZATION-MATERIEL**

Indicates that an ORGANIZATION may be associated with zero, one, or many occurrences of MATERIEL, and that an occurrence of MATERIEL may be associated with zero, one, or many occurrences of ORGANIZATION. ORGANIZATIONS may be assigned MATERIEL. ORGANIZATIONS manage and allocate MATERIEL to satisfy requirements.

**ORGANIZATION-PERSON**

Indicates that an ORGANIZATION may be associated with zero, one, or many occurrences of PERSON and that an occurrence of PERSON may be associated with zero, one, or many ORGANIZATIONS. ORGANIZATIONS are made up of PERSONS. ORGANIZATIONS acquire, train, and manage people (PERSONS) to satisfy requirements.

**ORGANIZATION-PLAN**

Indicates that an ORGANIZATION may be associated with zero, one, or many PLANS and a PLAN may be associated with zero, one, or many ORGANIZATIONS. ORGANIZATIONS develop PLANS related to assigned functions and responsibilities. In addition, ORGANIZATIONS perform PLANing functions within the context of the DoD PLANing, Programming, and Budgeting System to PLAN for the forces, systems, and programs required to accomplish national military strategy.

**APPENDIX D**  
**DoD STRATEGIC DATA MODEL GLOSSARY**

---

**ORGANIZATION-REAL ESTATE**

Indicates that an ORGANIZATION may be associated with zero, one, or many occurrences of REAL ESTATE and that an occurrence of REAL ESTATE may be associated with zero, one, or many ORGANIZATIONS. ORGANIZATIONS acquire, develop and manage REAL ESTATE.

**ORGANIZATION-SITUATION**

Indicates that an ORGANIZATION may be associated with zero, one, or many SITUATIONS and that a SITUATION may be associated with zero, one, or many ORGANIZATIONS. DOD ORGANIZATIONS monitor day-to-day events (SITUATIONS) and participate in various operations (SITUATIONS).

**ORGANIZATION TYPE**

The specification of a particular organization category.

**OTHER US GOVERNMENT ORGANIZATION**

An organization consisting of any identifiable group within the US government other than within DoD. Included are cabinet level organizations, Congress, and state, county, or city governments.

**PERSON**

A human being.

**PERSON-FACILITY**

Indicates that a PERSON may be associated with zero, one, or many occurrences of FACILITY and that an occurrence of FACILITY may be associated with zero, one, or many PERSONS.

**APPENDIX D**  
**DoD STRATEGIC DATA MODEL GLOSSARY**

---

**PERSON-LOCATION**

Indicates that a PERSON may be associated with zero, one, or many occurrences of LOCATION and that an occurrence of LOCATION may be associated with zero, one, or many occurrences of PERSON. The management and administration of PERSONS requires that the LOCATION of the PERSON be known. In some instances, planning activities include identifying future LOCATIONS of a PERSON.

**PERSON-MATERIEL**

Indicates that a PERSON may be associated with zero, one, or many occurrences of MATERIEL and that an occurrence of MATERIEL may be associated with zero, one, or many occurrences of PERSON. MATERIEL is issued to PERSONS as personal property, e.g., MATERIEL from the Central Issue Facility (CIF).

**PERSON TYPE**

The specification of a particular human being category.

**PLAN**

A scheme for achieving an end over time.

**PLAN-GUIDANCE**

Indicates that a PLAN must be associated with at least one occurrence of GUIDANCE and GUIDANCE may be associated with zero, one, or many PLANS. GUIDANCE is developed, coordinated, and issued for the preparation and review of operation and contingency PLANS. Standards and procedures (GUIDANCE) for the administration and management of approved PLANS are developed and published and PLANS are analyzed and evaluated to ensure adherence to DoD policies and national security directives (GUIDANCE).

**PLAN TYPE**

The specification of a particular scheme category.

**APPENDIX D  
DoD STRATEGIC DATA MODEL GLOSSARY**

---

**POINT**

A geometric element determined by an ordered set of coordinates.

**POLICY**

A statement of direction provided by corporate management.

**POLITICAL EVENT**

Any action, campaign, or event dealing with the study, structure, or affairs of government, or the state. A non-military action or occurrence which is effected by or directed toward some governmental organization.

**READINESS**

The capability of an organization, person, weapon system, or equipment to perform the missions or functions for which it is organized, designed, or trained.

**REAL ESTATE**

Land, improved or unimproved, along with natural resources.

**REAL ESTATE LOCATION**

Indicates that an occurrence of REAL ESTATE may be associated with zero, one, or many occurrences of LOCATION and that an occurrence of LOCATION may be associated with zero, one, or many occurrences of REAL ESTATE. Management and planning activities require that the LOCATION of REAL ESTATE be known. In some instances, planning activities include identifying future LOCATIONS of REAL ESTATE e.g., creation of islands from dredging actions.

**REAL ESTATE TYPE**

The specification of a particular real estate category.

**APPENDIX D**  
**DoD STRATEGIC DATA MODEL GLOSSARY**

---

**REVOLVING FUND**

A fund established to finance a cycle of operations to which reimbursements and collections are returned for reuse in a manner such as will maintain the principal of the fund (e.g., working capital funds, industrial funds, and loan funds).

**ROADWAY**

Physical property constructed and maintained to support vehicular and ground aircraft traffic, usually hard-surfaced (e.g., roads, railroads, runways, and taxiways).

**SITUATION**

A circumstance of governmental interest.

**SITUATION-GUIDANCE**

Indicates that a SITUATION may be associated with zero, one, or many occurrences of GUIDANCE and that GUIDANCE may be associated with zero, one, or many SITUATIONS. GUIDANCE is developed in response to SITUATIONS to direct actions. Performance is monitored and evaluated relative to GUIDANCE.

**SITUATION-LOCATION**

Indicates that a SITUATION must be associated with at least one, or many LOCATIONS and that a LOCATION may be associated with zero, one, or many SITUATIONS. The uses of various LOCATIONS in support of operations (SITUATIONS) are reviewed and evaluated. SITUATIONS that occur in different parts of the world (LOCATIONS) that may be sensitive to national security objectives shall be monitored and evaluated. Implicit is a need to know where (LOCATION) specific events (SITUATIONS) occur.

**SITUATION TYPE**

The specification of a particular state category.

---

**APPENDIX D**  
**DoD STRATEGIC DATA MODEL GLOSSARY**

---

**STATUTE**

A law.

**STRATEGY**

A command statement of general direction.

**STRUCTURE**

A building or construction built or arranged for a specific use or in a definite pattern of organization (e.g., buildings, towers, bridges, and permanent cranes).

**SUPPLY**

Materiel that is expendable, or consumable. Materiel and supply items used in the equipping, support and maintenance of organizations.

**SUSTAINABILITY**

The ability to maintain the necessary level and duration of operational activity to achieve recognized objectives.

**TREATY**

A formal arrangement between political authorities.

**UNDERSTANDING**

An implicit arrangement between parties.

**APPENDIX D**  
**DoD STRATEGIC DATA MODEL GLOSSARY**

---

**UNIFIED/SPECIFIED COMMAND**

A combatant command with a broad continuing mission, established and so designated by the President through the Secretary of Defense with the advice and assistance of the Joint Chiefs of Staff. An unified command is composed of components of two or more Services. A specified command is composed of forces from one Military Service only.

**US NON-GOVERNMENT ORGANIZATION**

An organization within the U.S. not associated with government.

**UTILITY**

A network of constructs and equipage designed to accommodate or provide services, such as electricity, water, natural gas, sewer, or communications.

**APPENDIX D**  
**DoD STRATEGIC DATA MODEL GLOSSARY**

---

**KEY-BASED ATTRIBUTE GLOSSARY**

**APPENDIX D**  
**DoD STRATEGIC DATA MODEL GLOSSARY**

---

**action id**

The unique identifier that represents an instance of action.

**action type id**

The unique identifier that represents a category of action.

**agreement id**

The unique identifier that represents an instance of agreement.

**agreement type id**

The unique identifier that represents a category of agreement.

**capability id**

The unique identifier that represents an instance of capability.

**capability type id**

The unique identifier that represents a category of capability.

**dod organization type id**

The unique identifier that represents a category of DoD organization.

**facility id**

The unique identifier that represents an instance of facility.

**facility type id**

The unique identifier that represents a category of facility.

**APPENDIX D**  
**DoD STRATEGIC DATA MODEL GLOSSARY**

---

**fund id**  
The unique identifier that represents an instance of fund.

**fund type id**  
The unique identifier that represents a category of fund.

**guidance id**  
The unique identifier that represents an instance of guidance.

**guidance type id**  
The unique identifier that represents a category of guidance.

**location id**  
The unique identifier that represents an instance of location.

**location type id**  
The unique identifier that represents a category of location.

**materiel id**  
The unique identifier that represents an instance of materiel.

**materiel type id**  
The unique identifier that represents a category of materiel.

**organization id**  
The unique identifier that represents an instance of organization.

---

**APPENDIX D**  
**DoD STRATEGIC DATA MODEL GLOSSARY**

---

**organization type id**

The unique identifier that represents a category of organization.

**person id**

The unique identifier that represents an instance of person.

**person type id**

The unique identifier that represents a category of person.

**plan id**

The unique identifier that represents an instance of plan.

**plan type id**

The unique identifier that represents a category of plan.

**real estate id**

The unique identifier that represents an instance of real estate.

**real estate type id**

The unique identifier that represents a category of real estate.

**situation id**

The unique identifier that represents an instance of situation.

**situation type id**

The unique identifier that represents a category of situation.

***THIS PAGE INTENTIONALLY  
LEFT BLANK***

**APPENDIX E**  
**CORE AND SUPPORT**  
**END-TO-END PROCESSES**

## CORE AND SUPPORT END-TO-END PROCESSES

Core and support end-to-end processes are structured sets of activities that cross functional and organizational boundaries to provide needed capabilities (products or services) to end-users. They begin with a valid requirement approved and funded by a customer and end with the delivery of the right "stuff" (e.g., units, supplies), at the right place and right time, to a consumer.

A typical end-to-end process in DoD is shown in Figure E-1. This process starts with the need for a new product (e.g., a weapons system). The requirement is approved and funding is requested from the Congress; once Congress has appropriated the funds, the product is developed by and acquired from an industry supplier; the product is introduced into the force structure; units are trained in the product's operation; and, ultimately, the product is employed by the Combatant CINC to conduct an operation.

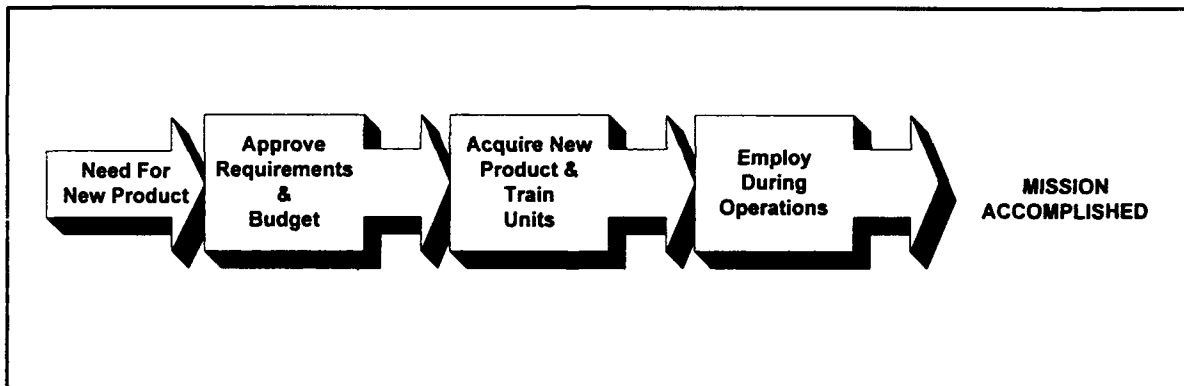

Figure E-1. DoD END-TO-END PROCESS EXAMPLE

Processes act as the lever by which enterprises can change the quality, quantity, timeliness, and cost of their products and services. The overall performance of a process is dependent on the quality, timeliness, and cost-effectiveness of each individual activity. If the performance of any one of the activities falls short, the performance of the entire process is degraded. The customer/consumer model helps managers define value chains of end-to-end processes for DoD by identifying the key activity drivers.

Figure E-2 illustrates the concept of end-to-end processes that cross the defense activities described in the DoD Enterprise Model. To maximize the effectiveness and efficiency of DoD operations, DoD senior leaders should focus on complete end-to-end processes; merely improving individual parts of a process, without first having done an overall process redesign, almost always leads to suboptimal solutions.

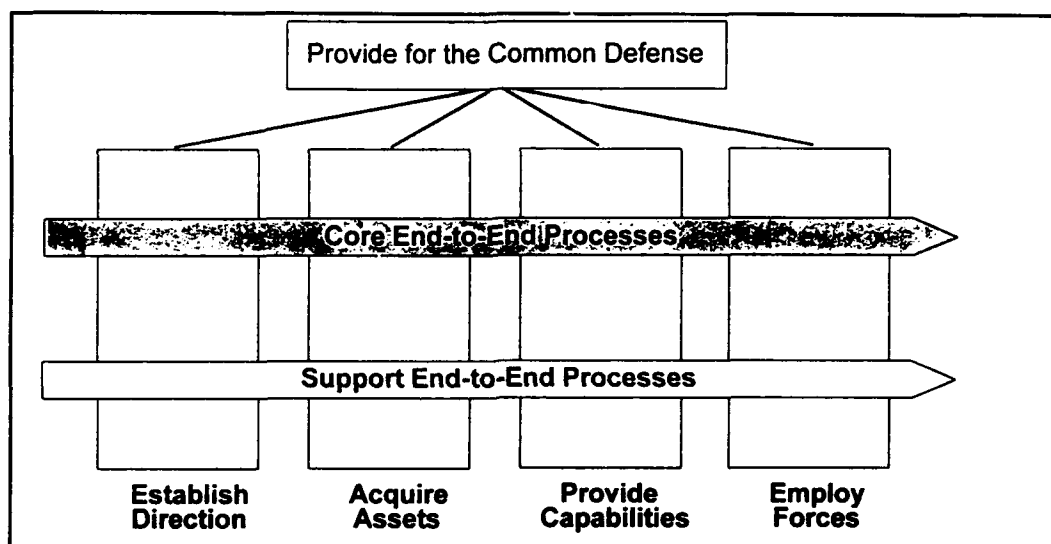

Figure E-2. DoD ENTERPRISE END-TO-END PROCESSES

We can distinguish two major types of end-to-end processes as shown in Figure E-2:

- **"Core"** defense processes, which are vital to the enterprise — they are mission-critical. These are the processes that provide the products and services to the Combatant CINCs to conduct military operations. For example, joint planning and operations is a core process. Core processes must be "world-class" whether they are performed by the military, civilians, allies, or industry partners.
- **"Support"** processes, which are essential to performing the core processes or are required by law and policy. For example, personnel transactions are essential support processes.

Identifying core and support processes facilitates strategic management of the Department. Putting together the right mix of skills and resources, processes and systems, from all functional areas, brings total defense resources to bear on missions. Therefore, re-engineering of end-to-end processes can yield the greatest benefit/cost impact for the enterprise.

End-to-end processes are built upon the traditional functions of the Department. They leverage excellence in "vertical" functions like finance by combining methods, people, and systems from different competencies to deliver solutions to problems. As part of a "horizontal" end-to-end processes, personnel, materiel, medical, finance, and other functions contribute to an end goal — mission success.

These end-to-end processes ("value chains") start with mission needs and measures, and end with products, services, and performance delivered to primary consumers (e.g., the Combatant CINCs). Intermediate customers and consumers must also be identified for each part of the value chain. If the costs exceed the benefits, process sponsors, "owners", and participants should re-engineer their (parts of) end-to-end processes to be more effective and efficient, taking into account the guidance and needs of interested customers, consumers, workers, and other stakeholders.

A set of candidate core processes has been defined and are depicted in Figure E-3. These candidate core processes must be validated and supplemented by key support processes.

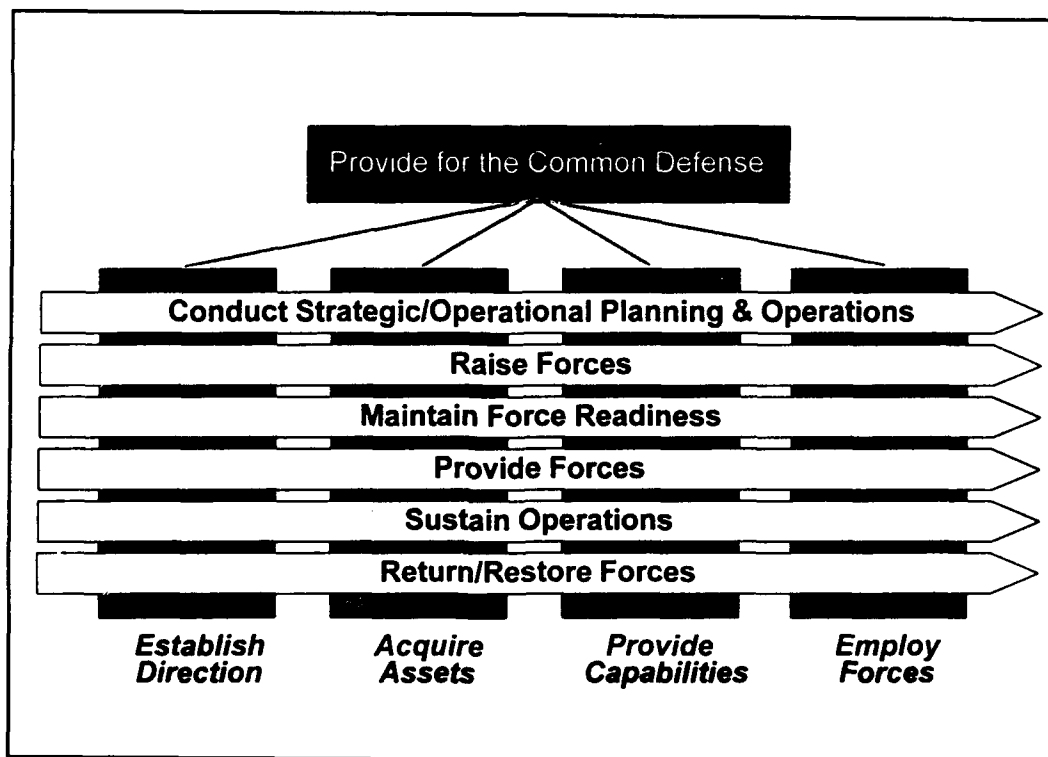

Figure E-3. CANDIDATE DoD CORE PROCESSES

- **Conduct Strategic/Operational Planning and Operations.** This end-to-end core process is develops nested sets of strategic and operational plans, starting with National Military Strategy, to accomplish the assigned missions of the Department, and executes the plans through the use of forces in the AOR.
- **Raise Forces.** This end-to-end core process develops doctrine and identifies the requirements for forces. It results in authorizations for personnel, equipment, supplies, and facilities, and an approved force program.
- **Maintain Force Readiness.** This end-to-end core process acquires the people, equipment, and items of supply needed to form forces ("man and equip" the force), integrates and trains the forces, and assesses the readiness of forces before they are delivered to Combatant CINCs.
- **Provide Forces.** This end-to-end core process mobilizes units to fill plan requirements, conducts pre-deployment training, transports units into AOR, and integrates them into forces.
- **Sustain Operations.** This end-to-end core process determines requirements for sustainment in terms of equipment, supplies, and personnel, acquires these assets, transports them to the AOR, and delivers them to consuming units.
- **Return/Restore Forces.** This end-to-end core process brings forces and assets back from the AOR after completion of an operation, demobilizes units and individuals, transports units to their home station, restores damaged assets, and returns assets to the inventory.

The senior DoD leaders can establish strategic goals and measures for activities which comprise each of the end-to-end processes. Functional managers can plan re-engineering and improvement initiatives to achieve the leadership's end-to-end objectives, as well as specific functional area and functional activity objectives.

The activities in the Enterprise Model are linked to core and support end-to-end processes. Because the Enterprise Model is being extended down to all functional areas and activities, it will be possible to develop end-to-end process chains at different levels, consistent with strategic goals, objectives, and measures of performance. Ultimately, the top direction of DoD will be linked to tasks, teams, and individuals. These "threads" will create a set of powerful linkages that let DoD bring all its skills and resources to bear on each unique operational mission.

**APPENDIX F**  
**REFERENCES**

## REFERENCES

1. *The Constitution of the United States.*
2. *Title 10, Armed Forces, United States Code.*
3. *Goldwater-Nichols Department of Defense Reorganization Act of 1986 (P.L. 99-433).*
4. *National Security Strategy of the United States.*
5. *National Military Strategy of the United States.*
6. *Joint Warfare of the US Armed Forces, Joint Pub 1, National Defense University Press, 11 November 1991.*
7. *FYDP Program Structure, DoD 7045.7-H, Office of the Comptroller, Department of Defense, April 1992.*
8. *Information Management Program, DoD Directive 8000.1, October 1992.*
9. *Functional Process Improvement (Functional Management Process for Implementing the Information Management Program of the Department of Defense), DoD 8020.1-M (Draft), Director of Defense Information, Office of the Secretary of Defense, August 1992.*
10. *DoD Data Administration, DoD Directive 8320.1, September 1991.*
11. *Data Element Standardization Procedures, DoD 8320.1-M-1, January 1993.*
12. *FIPS PUB 183, Integration Definition for Function Modeling, December 1993.*
13. *FIPS PUB 184, Integration Definition for Information Modeling, December 1993.*

**APPENDIX G**

**COMMENTS**

## COMMENTS

The following organizations provided insightful recommendations and suggestions regarding *The DoD Enterprise Model: A White Paper*, February 1993 and January 1994. Many of these suggestions were incorporated into this version. Their efforts and assistance are greatly appreciated.

### Offices of the Under Secretaries of Defense

The Under Secretary of Defense  
Acquisition

Leland G. Jordan  
Deputy Director  
Program & Budget  
Integration

### Offices of the Assistant Secretaries of Defense

Office of the Assistant Secretary of Defense  
Command, Control, Communications and  
Intelligence

S. J. Davidson  
FDAd, Intelligence

Office of the Assistant Secretary of Defense  
Production and Logistics

James H. Reay  
Director  
Logistics Systems  
Development

Office of the Assistant Secretary of Defense  
Special Operations/Low Intensity Conflict

Mr. H. Allen Holmes  
Assistant Secretary of Defense  
Special Operations/  
Low Intensity Conflict

### Office of the Joint Chiefs of Staff/Commanders in Chief

Joint Chiefs of Staff

Joe Toma

United States Strategic Command

Al Fransen

Larry Sipos  
Colonel, USAF  
Chief, Computer Systems  
Management Division

P. A. Moore, Jr.  
CAPT, USN  
Chief, C4I Systems Policy,  
Plans and Requirements  
Division

**The Department of the Army**

Department of the Army,  
Office, Director of Information Systems for  
Command, Control, Communications & Computers

Carla K. Fisher  
Deputy Director for  
Corporate Information  
Management

Department of the Army  
Headquarters,  
U.S. Army Materiel Command

Tommy T. Osborne  
Colonel, GS  
Corporate Information  
Officer

Department of the Army  
Office of the Secretary of the Army  
Office, Director of Information Systems for  
Command, Control, Communications &  
Computers

Miriam F. Browning  
Director of Army  
Information

Department of the Army  
U.S. Army Materiel Command

Thomas L. Prather, Jr.  
Major General, USA  
Deputy Chief of Staff for  
Research, Development and  
Engineering

Department of the Army  
U.S. Army Materiel Command

Sandra Rittenhouse  
Acting Chief, Procurement  
Management Division  
Office of the Deputy Chief of  
Staff for Acquisition

Department of the Army  
U.S. Army Materiel Command

John J. McCarthy  
Assistant Deputy Chief of Staff  
for Logistics

Department of the Army  
U.S. Army Materiel Command

Arthur J. Gipson  
Colonel, GS  
Assistant Deputy Chief of Staff  
for Personnel

Department of the Army  
U.S. Army Materiel Command

John W. Gill, Jr.  
Chief, Functional/Technical  
Information Management  
Division

Department of the Army  
U.S. Army Materiel Command

David S. Abdelnour  
Assistant Chief of Staff for  
Engineering, Housing,  
Environment, and Installation  
Logistics

Department of the Army  
Headquarters  
United States Army, Europe, and Seventh Army  
Office of the Deputy Chief of Staff, IM

John O. Welch  
Colonel, GS  
Assistant Deputy Chief of Staff,  
Information Management

Department of the Army  
Headquarters,  
United States Army, Pacific

Joann Maruoka  
Chief, Plans and Resources  
Division

Department of the Army  
Office of the Secretary of the Army  
Office, Chief of Legislative Liaison

Janet Fagan  
Information Systems Manager

Department of the Army  
U.S. Army Information Systems Software Center

James L. Glymph  
Director, Data Management

Department of the Army  
U.S. Army Military Traffic Management Command

Edwin F. Rappe  
Deputy Chief of Staff for  
Information Management

Department of the Army  
U.S. Army Plans and Operations  
Information Support Agency

Dave Mercer  
Director

Department of the Army  
U.S. Army  
TRADOC

David G. Fitz-Enz  
Colonel, GS  
Deputy Chief of Staff for  
Information Management

Department of the Army  
Headquarters  
U.S. Army Health Services Command

J. M. Cook  
LTC, AG  
Chief, Administrative Services  
Division

Department of the Army  
Office of the Surgeon General

Arthur S. Irish, II  
COL, MS  
Chief, Information Management

Department of the Army  
Headquarters  
United States Army Special Operations Command

Anthony H. Normand  
Colonel, GS  
Chief of Staff

Department of the Army  
U.S. Army Corps of Engineers

Billy J. Ricks  
Colonel, Corps of Engineers  
Director of Information  
Management

The Department of the Army  
Standards Division  
Office of the Director of Information Systems  
Command, Control, Communications, and  
Computers (ODISC4)

Department of the Army  
U.S. Army Information Systems Command

G. A. Mackay  
Assistant Deputy Chief of Staff  
for Information Management

Department of the Army  
Office of the Program Executive Officer  
Standard Army Management Information Systems  
Project Manager  
Joint Computer-Aided Acquisition and Logistic Support

James E. Tomlinson, Ph. D  
Project Manager

### **The Department of the Navy**

Department of the Navy  
Naval Air Warfare Center

Jerry Brown  
Data Administrator

Department of the Navy  
Naval Air Systems Command  
Naval Air Systems Command Headquarters

Jill Vines Loftus  
Commander  
Naval Air Systems Command

Department of the Navy  
Office of Assistant Secretary  
(Research Development & Acquisition)

Mr. J. G. Hekman  
Principle Assistant for IRM

### **The Department of the Air Force**

Department of the Air Force  
Headquarters  
Air Force Command, Control, Communications,  
and Computer Agency (AFC4A)

James G. Neighbors, GM-14  
Chief, Data Administration  
Branch

Department of the Air Force  
TRANSCOM

Department of the Air Force  
Headquarters  
Air Force Command, Control, Communications,  
and Computer Agency (AFC4A)

LtGen Carl G. O'Berry

## **Defense Agencies**

**Advanced Research Projects Agencies**

**Mr. Gregory Colocotronis**  
**Comptroller**

**Ballistic Missile Defense Organization**

**Ms. Jeanette Clay**  
**Director, Information Systems**

**Defense Finance and Accounting Service**

**Arnold R. Weiss**  
**Deputy Director for Business**  
**Information Management**

**Defense Information Systems Agency**  
**Center for Information Management**

**Belkis Leong-Hong**  
**Acting Director**

**Defense Intelligence Agency**

**Lari D. Anderson**  
**Chief, DS Systems Integration**  
**Management Staff**

**James R. Clapper, Jr.**  
**Lieutenant General, Director**

**Defense Investigative Service**

**Mr. John Donnelly**  
**Director**

**Defense Logistics Agency**

**Mr. Thomas Knapp**  
**Chief Information Officer**

**Defense Mapping Agency**  
**Headquarters**

**Kathleen M. Smith**  
**Deputy Director for Information**  
**Systems**

**Defense Performance Review**

**Lt. General Thomas G. McNemey**  
**Director**

National Security Agency

Isaiah C. Cole, RADM, USN  
Deputy Director for Plans, Policy,  
and Programs

On-Site Inspection Agency

Brain Mullady  
Colonel, U.S. Army, Chief of Staff

**Federally Funded Research and Development Centers**

MITRE

James E. Just  
Associate Department Head  
Defense Information Systems  
Engineering

**Defense Contractors**

Computer Sciences Corporations  
CALs Imaging Center

Norma Kornwebel  
PM JCALS

D. Appleton Company, Inc.

Dan Appleton  
President

General Research Corporation

Barbara D. Gorsen  
Director  
Technical Support Group

Martin Marietta Astronautics Group

Ronald L. Schuldt  
Manager, External Initiatives

Raytheon

Barbara A. Barman  
Deputy Chairman  
ISG Data Classification  
Methodology Working  
Committee