



AIM

Association for Information and Image Management

1100 Wayne Avenue, Suite 1100
Silver Spring, Maryland 20910

301/587-8202

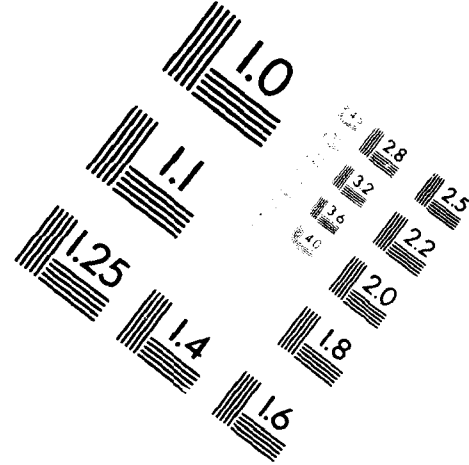
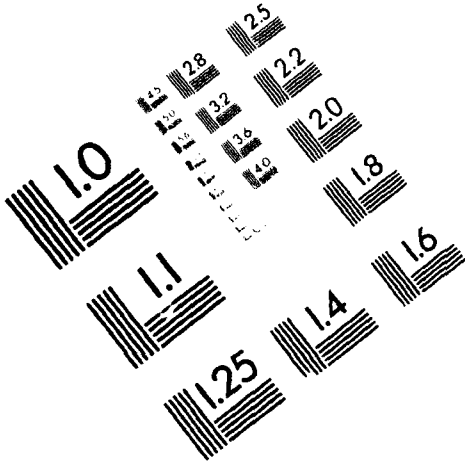

Centimeter

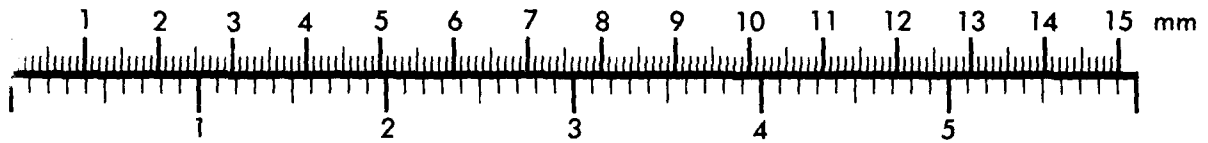

Inches

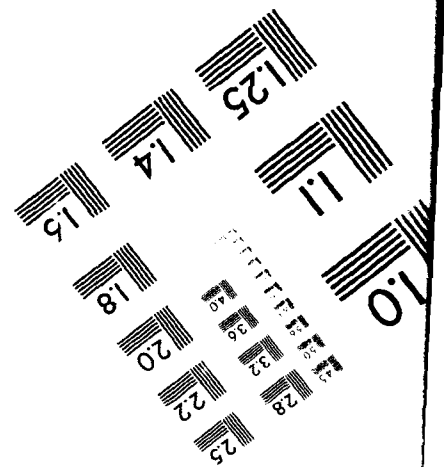
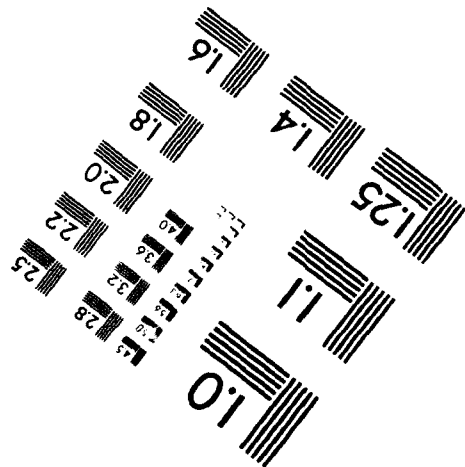
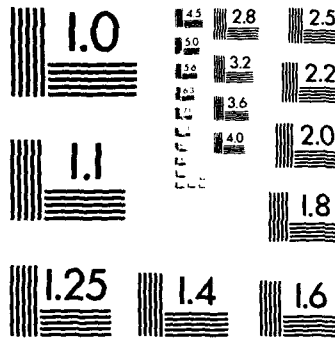

MANUFACTURED TO AIM STANDARDS
BY APPLIED IMAGE, INC.

1



AD-A284 971

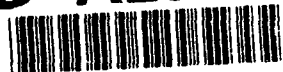

The Assessment of the AH-64D, Longbow, Mast-Mounted Assembly Noise Hazard for Maintenance Personnel

By

Ben T. Mozo
Elmaree Gordon

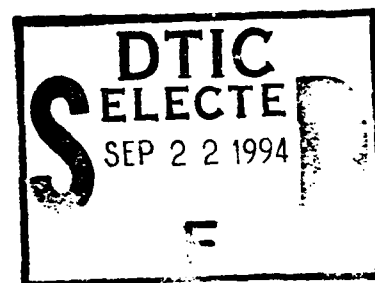

Aircrew Protection Division

July 1994

409 94-30377

Approved for public release; distribution unlimited.

94 0 21 0 11

DTIC QUALITY...

United States Army Aeromedical Research Laboratory
Fort Rucker, Alabama 36362-0577

Notice

Qualified requesters

Qualified requesters may obtain copies from the Defense Technical Information Center (DTIC), Cameron Station, Alexandria, Virginia 22314. Orders will be expedited if placed through the librarian or other person designated to request documents from DTIC.

Change of address

Organizations receiving reports from the U.S. Army Aeromedical Research Laboratory on automatic mailing lists should confirm correct address when corresponding about laboratory reports.

Disposition

Destroy this document when it is no longer needed. Do not return it to the originator.

Disclaimer

The views, opinions, and/or findings contained in this report are those of the author(s) and should not be construed as an official Department of the Army position, policy, or decision, unless so designated by other official documentation. Citation of trade names in this report does not constitute an official Department of the Army endorsement or approval of the use of such commercial items.

Reviewed:

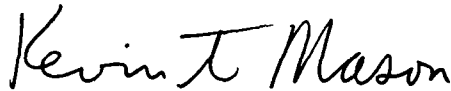

KEVIN T. MASON
LTC, MC, MFS
Director, Aircrew Protection
Division

Released for publication:

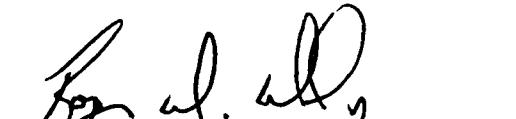
ROGER W. WILEY, O.D., Ph.D.
Chairman, Scientific
Review Committee

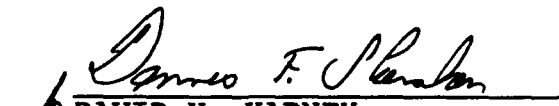
DAVID H. KARNEY
Colonel, MC, SFS
Commanding

REPORT DOCUMENTATION PAGE

1a. REPORT SECURITY CLASSIFICATION Unclassified		1b. RESTRICTIVE MARKINGS	
2a. SECURITY CLASSIFICATION AUTHORITY		3. DISTRIBUTION / AVAILABILITY OF REPORT Approved for public release, distribution unlimited	
2b. DECLASSIFICATION / DOWNGRADING SCHEDULE			
4. PERFORMING ORGANIZATION REPORT NUMBER(S) USAARL Report No. 94-37		5. MONITORING ORGANIZATION REPORT NUMBER(S)	
6a. NAME OF PERFORMING ORGANIZATION	6b. OFFICE SYMBOL (If applicable)	7a. NAME OF MONITORING ORGANIZATION	
6c. ADDRESS (City, State, and ZIP Code)		7b. ADDRESS (City, State, and ZIP Code)	
8a. NAME OF FUNDING / SPONSORING ORGANIZATION Project Manager, Longbow	8b. OFFICE SYMBOL (If applicable) SPAE-AV-LB-S	9. PROCUREMENT INSTRUMENT IDENTIFICATION NUMBER	
8c. ADDRESS (City, State, and ZIP Code) 4300 Goodfellow Boulevard St. Louis, MO 63120-1798		10. SOURCE OF FUNDING NUMBERS	
		PROGRAM ELEMENT NO.	PROJECT NO.
		TASK NO.	WORK UNIT ACCESSION NO.
11. TITLE (Include Security Classification) The assessment of the AH-64D, Longbow, mast mounted assembly noise hazard for maintenance personnel			
12. PERSONAL AUTHOR(S) Ben T. Moz and Elmaree Gordon			
13a. TYPE OF REPORT Final	13b. TIME COVERED FROM _____ TO _____	14. DATE OF REPORT (Year, Month, Day) 1994 July	15. PAGE COUNT 30
16. SUPPLEMENTARY NOTATION			
17. COSATI CODES		18. SUBJECT TERMS (Continue on reverse if necessary and identify by block number)	
FIELD	GROUP	Noise levels, AH-64 helicopter, hearing protection, noise hazards	
01	03		
06	04		
19. ABSTRACT (Continue on reverse if necessary and identify by block number) Noise levels around the AH-64 helicopter exceed safe limits. Maintenance personnel are required to wear hearing protection to reduce hazard to hearing while performing maintenance procedures. This evaluation was directed at determining the contribution to noise levels by the auxiliary power unit (APU), auxiliary ground power unit (AGPU), environmental control system (ECS), and mast mounted assembly (MMA) at a variety of maintenance positions and establish protection capabilities of standard protectors for those noise levels.			
20. DISTRIBUTION / AVAILABILITY OF ABSTRACT <input checked="" type="checkbox"/> UNCLASSIFIED/UNLIMITED <input type="checkbox"/> SAME AS RPT. <input type="checkbox"/> DTIC USERS		21. ABSTRACT SECURITY CLASSIFICATION Unlimited	
22a. NAME OF RESPONSIBLE INDIVIDUAL Chief, Science Support Center		22b. TELEPHONE (Include Area Code) 205-255-6907	22c. OFFICE SYMBOL SGRD-UAX-SI

Table of contents

	Page
Introduction	3
Method and instrumentation	3
Results and discussion	5
Conclusions	8
References	10
Manufacturer's list	11

List of tables

Table

1. Positions around the AH-64 where sound measurements were made	4
2. Noise levels in dB during APU operation for the indicated positions and test conditions	12
3. Noise levels in dB during AGPU operation for the indicated positions and test conditions	14
4. Noise levels in dB during hangar operation for the indicated positions and test conditions	16
5. Noise levels in dB during maintenance operation for the indicated positions and test conditions	18
6. Effective noise exposure level in dBA and allowable exposure time in minutes for individuals wearing the triple flange earplug	19
7. Effective noise exposure level in dBA and allowable exposure time in minutes for individuals wearing the V-51R earplug	19
8. Exposure levels in dB while wearing hearing protection during APU operation	20
9. Exposure level in dB while wearing hearing protection during AGPU operation	25
10. Noise levels in dB around the AGPU at distances of 6 feet and 12 feet	30

List of figures

Figure		Page
1.	Measurement locations around the AGPU at 6 feet and 12 feet from the unit	6
2.	85 dBA contour for the AH-64D operating with APU and ECS and MMA on	7

Accession For	
NTIS CRA&I	<input checked="" type="checkbox"/>
DTIC TAB	<input type="checkbox"/>
Unannounced	<input type="checkbox"/>
Justification	
By	
Distribution/	
Availability Codes	
Dist	Avail and/or Special
A-1	

Introduction

Noise levels produced by the mast mounted assembly (MMA) during maintenance procedures and bench maintenance, and while mounted on the aircraft, are expected to exceed levels which are safe for personnel as described by Department of Defense instruction 6055.12, "Hearing conservation." This study was conducted to determine noise levels produced by the MMA, environmental control system (ECS), and other aircraft systems during ground operations with the aircraft powered by the auxiliary power unit (APU), auxiliary ground power unit (AGPU), and 400-cycle hangar power. The objective of the study was to establish main contributors to noise and determine noise levels at several maintenance locations where personnel are likely to perform their duties.

Method and instrumentation

Noise levels were measured in accordance with MIL-STD-1474C, "Noise limits for Army Materiel " and MIL-STD-1294, "Acoustical noise limits in helicopters." Noise level determinations were limited to steady state noise levels.

An 85 dBA noise contour around the helicopter was determined using a Larson Davis sound level meter* (SLM), Model 800, which is a type I as defined by American National Standards Institute (ANSI) S1.4-1983, "Specification for sound level meters." Measurements were made for the worst case open field operational condition which was APU powered with ECS and MMA on. The contour was estimated from measurements completed at several radii around the aircraft using the rotor shaft as the center reference point.

Noise samples were recorded using a Nagra portable tape recorder*, Model IV-SJ, at each of the locations for all test conditions included in this study with the exception of the contour measurement. The noise was measured using two Bruel and Kjaer (B&K) one-half inch microphones*, model 4165 which were powered and conditioned by B&K preamplifiers*, model 2619. The system was calibrated before and after each measurement session using a B&K pistonphone*, model 4220. The tape recorder was operated at 7.5 inches per second (IPS) which yielded a recording bandwidth of 25 Hz to 20 kHz. The recorded noise samples were analyzed, using a Larson Davis real time analyzer*, Model 3100. The data were analyzed into one-third octave band levels at standard one-third octave frequency intervals defined by ANSI Standard S1.11-1986, "Specification for octave-band and

* See manufacturer's list

fractional octave-band analog and digital filters." The one-third octave band levels were converted into octave band levels for further analysis and reporting.

Noise measurements were completed on the MMA while operated in a bench maintenance configuration at the Martin Marietta East Side facility at Orlando, Florida. Recordings were made at four locations around the MMA which are likely to be occupied by maintenance personnel. The MMA was operated in a high, open bay room with the nearest reflecting surface approximately 20 feet from the MMA. The MMA was mounted on a test stand at a height of approximately 3.5 feet. Measurements were made at four locations about 4 feet horizontally from the center of the MMA. Position 1 was located on the left side while facing the opening of the MMA. The other three positions were located at 90 degree intervals in a counterclockwise direction.

Noise measurements were completed for the MMA while mounted and operating on the aircraft. Noise levels were measured at 13 positions where personnel may be required to perform their duties. The approximate locations are described in Table 1. Three aircraft operating conditions were evaluated for noise levels which were 1) aircraft powered, 2) aircraft powered and ECS on, and 3) aircraft powered with ECS and MMA on. Measurements were completed with the aircraft powered by the internal APU, AGPU, and 400-cycle power for the hangar operation.

Table 1.

Positions around the AH-64 where sound measurements were made.

<u>Position</u>	<u>Location description</u>
1	Step area, forward of mast
1A	Left side of mast, blade level
2	Step area, aft of mast
3	Step area, aft of mast, at end of ramp
4	Right engine, work platform
5	Left engine, work platform
6	Left wing
7	Right wing
8	Left side, forward avionics bay
9	Right side, forward avionics bay
10	Left side, aft avionics bay door
11	Right side, aft storage bay door
12	Right side, walkway at pilot canopy door
13	Pilot
14	Copilot, gunner

Free field measurements using the APU and AGPU as the power source for the aircraft were conducted in an open space with the nearest structure located more than 100 feet away. Measurements also were conducted in the hangar at the Martin Marietta facility. Dimensions of the hangar are 78 feet wide, 100 feet long, and 35 feet high. The door was open during the data collection. Dimensions of the door opening are 40 feet wide and 17 feet high.

Noise levels around the AGPU were included in the study since it may become a significant part of an individual's noise exposure for certain maintenance activities. Noise levels around the AGPU were measured at 8 locations at distances of 6 feet and 12 feet from the edge of the unit. Position 1 was centered on the meter panel side with the subsequent seven locations located at the corners and center of each side in a clock wise direction as shown in Figure 1.

Results and discussion

Figure 2 shows the 85 dBA noise contour as measured under free field conditions for the worst case operation: APU with ECS and MMA on. This contour indicates highest levels around the aircraft are in the right-rear quadrant, due primarily to the APU operation. The contour extends beyond 50 feet from the rotor shaft in the rear right quadrant direction. Most of the aircraft is within the 85 dBA contour, indicating hearing protection is required for all individuals during APU operation.

Results of the noise data analysis shown in Tables 2 to 5 include octave band levels with A-weighted and linear overall levels. Noise levels are shown using a three letter code to indicate the condition of the measurement along with positions described in Table 1. The first character signifies the power source with "A" indicating APU, "G" indicating AGPU, and "H" indicating 400-cycle power in the hangar. The second character signifies ECS on (1) or ECS off (0) while the third character signifies MMA on (1) or MMA off (0). The data show the distribution of acoustical energy across the frequency spectrum for each position and condition included in this study. The octave band data also were used to establish hearing hazard associated with the noise condition when using various hearing protector schemes.

The distribution of levels in dBA around the aircraft vary significantly and are highly dependent on the power source. Highest noise levels were present during APU operation while lowest levels are present during hangar operation. ECS and MMA contributions to the noise can best be determined during measurements conducted with the aircraft being powered by the 400-cycle power.

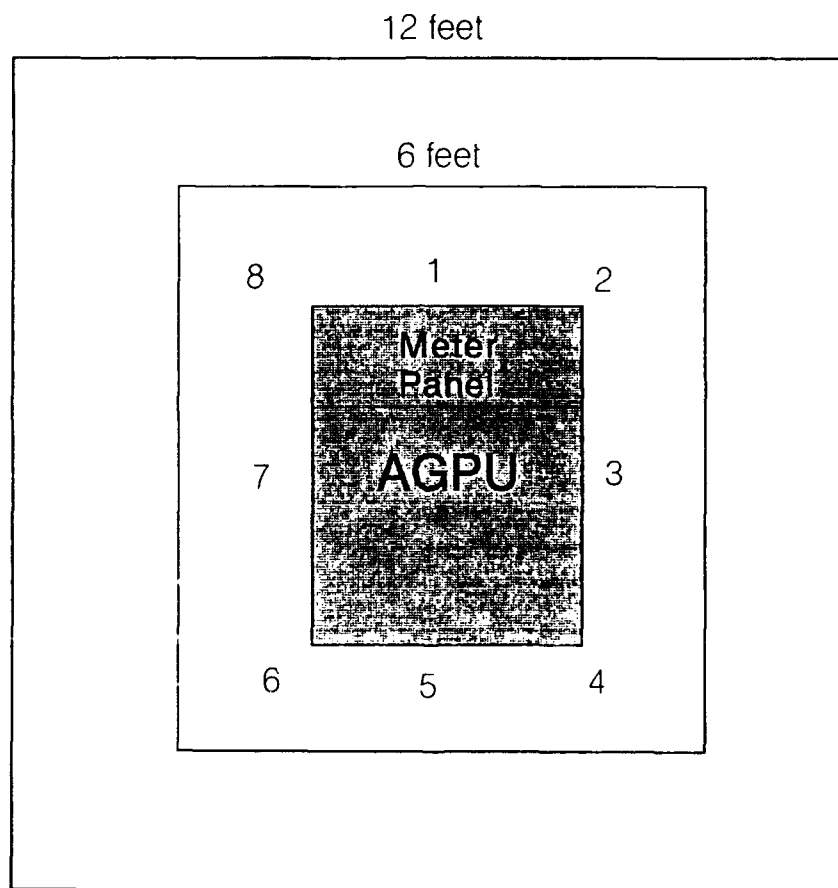

Figure 1. Measurement locations around the AGPU at 6 feet and 12 feet from the unit.

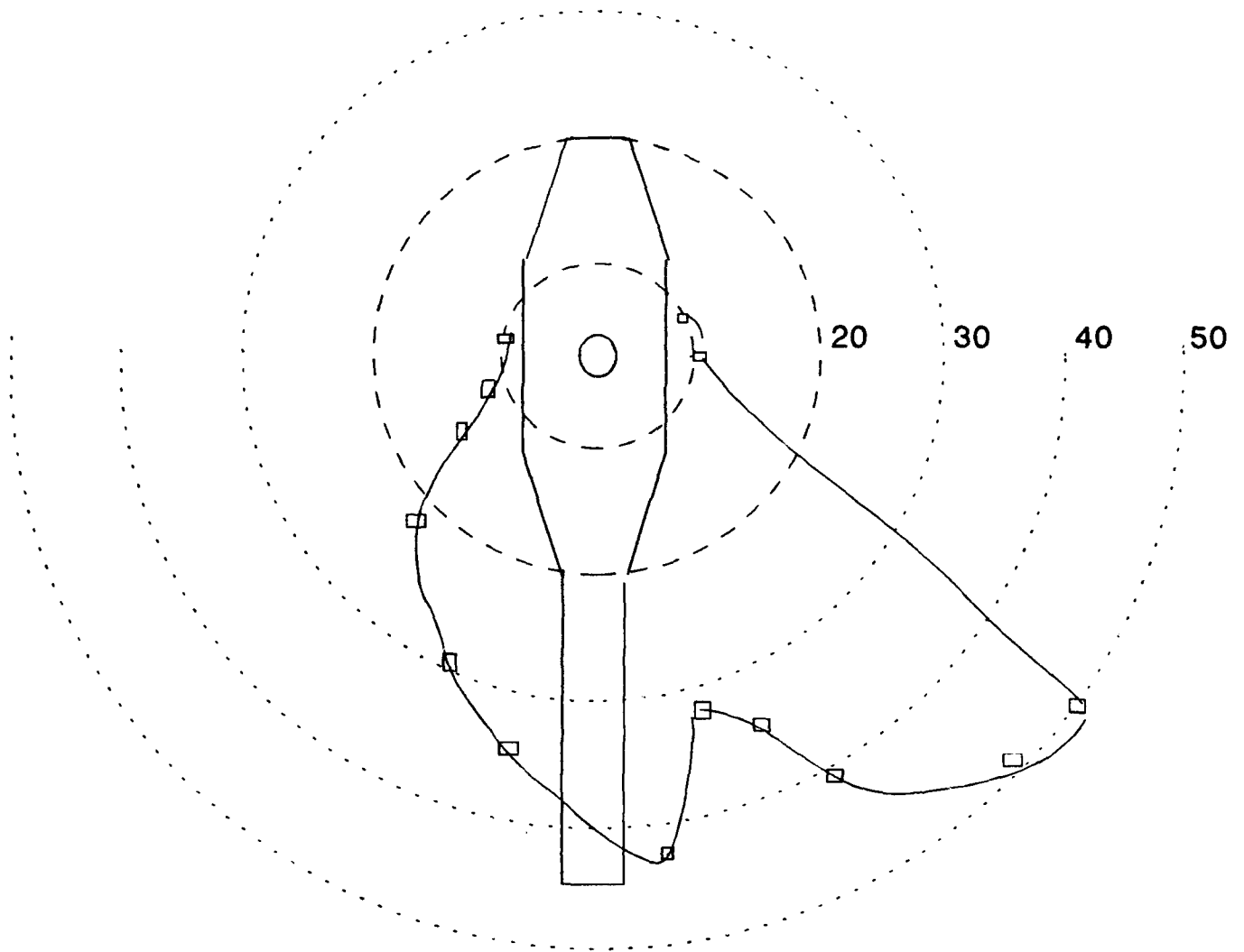

Figure 2. 85 dBA contour for the AH-64D operating with APU and ECS and MMA on.

Results of the noise analysis were used to determine the effective noise exposure level (EEL) for personnel working at the potential maintenance locations while wearing standard hearing protection. The yellow foam earplug, triple flange earplug, and V-51R earplug were selected as the hearing protectors likely to be used by the maintenance technicians. The EEL is calculated by subtracting dB values (the measured attenuation of the hearing protector in each octave band reduced by one standard deviation) and the band's A-weighted value from the measured octave band noise level. The resultant dB values are converted into pressure levels which are squared and summed for all of the frequency bands. This sum then is converted into dB which is the estimate of the overall dBA level at the ear of the individual wearing that particular hearing protector. The allowable effective exposure time (EET) for noise levels above 85 dBA also was calculated. The calculation uses 85 dBA as an allowable 8-hour exposure with exposure time being halved for each 3 dB above 85 dBA. EETs which are above the 85-dBA level are shown in Tables 6 and 7. Tables 8 and 9 show calculations of EEL for APU and AGPU operations for all positions and conditions. The effective exposure analysis indicates yellow foam earplugs reduce noise levels at the ear below 85 dBA at all positions for all test conditions. The triple-flange and V-51R earplugs do not reduce noise levels below 85 dBA for the area around the rear avionics bay and the ramp area behind the mast.

Table 10 shows noise levels measured around the AGPU during operation with no load. The AGPU was positioned at the location where noise measurements on the AH-64D were conducted. The nearest reflective structure was more than 100 feet away. Noise around the AGPU exceeds 85 dBA for most of the locations at 6 feet, indicating hearing protection should be worn.

Conclusions

Noise levels exceed 85 dBA for most positions around the aircraft while powered by the APU or AGPU. The ECS and MMA are significant contributors to the overall noise levels at many of the maintenance locations around the aircraft. During APU operation, noise levels near the rear avionics bay are extremely hazardous to hearing. Special effort to warn personnel of the high noise levels present in this area should be considered. When possible, the choice of protection to be used in this area should be the yellow foam earplug.

Noise levels around the MMA during bench maintenance activities are in excess of 85 dBA for most of the positions evaluated. Hearing protection should be worn while performing maintenance on the device. Levels may increase significantly if the MMA is located in a different maintenance structure.

The AGPU contributes to overall noise levels when used to power the aircraft system. Noise levels around the AGPU exceed 85 dBA which requires personnel to wear hearing protection.

References

American National Standards Institute. 1983. Specification for sound level meters. ANSI S1.4-1983.

American National Standards Institute. 1986. Specification for octave-band and fractional octave-band analog and digital filters. ANSI S1.11-1986.

Department of Defense. 1981. Acoustical noise limits in helicopters. Washington, DC: MIL-STD-1294.

Department of Defense. 1991. Hearing conservation. Washington, DC: Department of Defense Instruction 6055.12.

Department of Defense. 1990. Noise limits for military materiel. Washington, DC: MIL-STD-1474C.

Manufacturer's list

Bruel and Kjaer Instruments, Inc.
5111 West 164th Street
Cleveland, OH 44142

Cabot Safety Corporation (E-A-R)
5457 West 79th Street
Indianapolis, IN 46268

Larson Davis
1681 West 820 North
Provo, UT 84601

NAGRA, Kudelski S.A. Department NAGRA
CH 1033 Cheseaux
Switzerland

Sensor Electronics, Inc.
56 Bridge Road
Medford, NJ 08055-4205

Table 2.

Noise levels in dB during APU operation for the indicated positions and test conditions.

Position	Condition	31.5	63	125	250	500	1000	2000	4000	8000	AWT	LIN
1	A00	66.1	79.8	87.0	86.8	89.0	85.2	84.1	87.2	77.1	92.6	94.9
1	A01	68.2	82.5	92.4	90.9	91.2	87.5	87.3	92.1	79.4	96.2	98.6
1	A11	68.9	81.0	87.1	87.8	90.0	89.2	88.8	94.8	86.1	98.2	98.6
1A	A00	70.9	84.2	90.5	89.0	91.3	92.2	93.4	101.7	89.2	104.1	103.7
1A	A01	72.3	85.3	91.4	90.2	91.4	97.5	96.0	97.8	90.3	103.0	103.2
1A	A11	71.7	83.0	89.4	87.0	91.2	92.5	93.9	95.0	89.3	100.2	100.6
2	A00	68.1	82.3	88.1	90.6	90.3	92.2	86.8	85.2	79.8	95.3	97.6
2	A01	68.6	82.3	89.0	90.9	90.6	90.9	86.3	85.8	79.8	94.8	97.4
2	A11	73.0	83.8	90.2	91.2	93.4	95.9	91.8	91.9	90.3	100.0	101.2
3	A00	72.4	85.9	89.5	94.2	97.3	92.7	92.4	93.2	88.6	100.2	102.3
3	A01	72.6	85.4	89.2	93.1	96.1	94.5	92.7	92.8	85.9	100.1	101.6
3	A11	75.0	87.5	92.5	97.0	97.6	96.8	94.2	94.9	90.3	102.3	104.3
4	A00	72.0	86.2	91.7	98.4	96.0	95.9	90.3	90.4	82.9	99.9	102.8
4	A01	72.2	84.6	92.3	95.3	94.4	95.3	90.6	90.3	84.0	99.1	101.5
4	A11	73.4	84.5	92.7	97.1	95.2	94.0	90.2	88.5	83.6	98.6	101.8
5	A00	71.2	83.7	90.0	89.7	88.8	93.1	91.7	89.4	88.5	98.5	100.9
5	A01	71.5	83.1	89.7	87.7	91.0	95.0	92.9	90.7	83.9	99.1	100.0
5	A11	71.2	81.1	89.8	88.0	88.5	93.4	89.1	88.2	82.9	96.8	98.2
6	A00	63.5	72.1	81.6	82.5	83.0	85.5	82.4	79.7	75.6	89.4	91.0
6	A01	65.0	73.3	82.9	82.9	81.5	81.8	82.1	81.9	75.2	88.3	90.3
6	A11	66.1	72.3	84.2	84.0	83.7	82.8	85.7	85.8	78.9	91.4	92.6
7	A00	66.8	75.4	82.8	91.3	88.7	87.5	85.5	90.9	81.6	95.2	96.7
7	A01	66.2	74.4	83.1	91.2	86.0	87.7	84.6	83.2	77.8	92.3	94.9
7	A11	66.7	75.6	82.7	88.7	87.0	87.3	83.5	86.9	79.2	92.7	94.5
8	A00	69.1	72.3	75.4	78.4	76.2	81.2	75.4	75.6	65.7	84.0	85.8
8	A01	65.1	70.4	74.0	77.9	78.2	85.0	78.1	76.1	70.0	86.9	87.8
8	A11	66.8	69.1	74.0	78.8	78.9	79.5	74.2	76.7	71.9	83.6	85.7
9	A00	70.1	74.9	79.9	77.7	79.8	81.8	78.2	80.3	71.3	86.4	88.0
9	A01	65.9	73.0	78.3	80.2	81.7	79.6	78.6	76.9	70.8	85.2	87.5
9	A11	66.8	71.7	78.0	81.1	84.5	81.2	77.3	76.3	71.9	86.1	88.6

Table 2 (continued).

Position	Condition	31.5	63	125	250	500	1000	2000	4000	8000	AWT	LIN
10	A00	69.1	75.9	82.8	87.5	86.0	87.8	88.6	80.4	77.0	93.0	94.4
10	A01	71.5	78.0	84.8	88.9	90.1	91.6	82.9	79.4	75.7	93.5	96.0
10	A11	70.7	76.4	80.5	86.1	85.8	89.7	84.4	79.6	75.1	91.9	93.6
11	A00	82.8	86.3	95.0	99.7	104.3	102.0	96.0	101.5	103.9	108.6	110.7
11	A01	81.9	85.7	95.5	100.6	105.2	101.5	95.1	99.3	102.1	107.7	110.0
11	A11	83.4	86.0	96.0	101.0	105.0	101.7	96.5	100.1	102.9	108.2	110.4
12	A00	69.1	76.6	84.1	85.7	86.0	87.5	89.6	88.3	78.4	94.6	95.3
12	A01	73.5	76.1	83.4	87.6	86.6	86.8	84.1	91.5	79.5	94.8	95.5
12	A11	68.4	76.1	84.9	87.1	86.7	86.2	85.6	88.7	79.5	93.4	94.7
13	A00	74.2	82.9	87.7	80.2	81.1	80.0	81.9	79.2	74.3	87.1	91.5
13	A01	77.5	82.5	86.5	78.6	81.5	79.9	77.4	85.9	70.5	88.9	91.6
13	A11	72.0	82.0	85.2	77.2	80.5	81.4	78.0	78.1	72.8	85.8	89.8
14	A00	76.0	77.9	83.1	78.6	81.2	76.6	79.0	76.2	67.6	84.3	88.4
14	A00	75.3	76.4	82.5	78.6	82.3	77.4	78.6	72.3	66.8	84.0	88.1
14	A01	79.0	75.3	81.5	84.6	82.4	79.4	81.2	73.7	70.7	86.2	89.9
14	A01	78.6	76.7	82.9	80.4	83.1	78.5	77.7	74.1	67.5	84.6	89.0
14	A11	74.4	75.4	81.8	80.3	83.9	77.2	79.9	74.3	68.2	85.2	88.8
14	A11	75.1	76.5	83.7	80.8	84.1	77.6	78.6	73.1	68.1	84.8	89.3

Table 3.

Noise levels in dB during AGPU operation for the indicated positions and test conditions.

Position	Condition	31.5	63	125	250	500	1000	2000	4000	8000	AWT	LIN
1	G00	71.4	77.3	82.3	86.4	86.4	84.4	77.9	74.3	74.3	88.1	91.8
1	G01	70.4	76.9	81.2	86.7	86.7	91.5	82.2	81.0	76.4	93.2	94.6
1	G11	71.3	77.1	81.9	86.7	86.3	89.9	82.5	86.6	78.9	93.2	94.5
1A	G00	71.3	76.3	80.5	84.3	88.4	87.5	78.7	73.6	69.8	89.7	92.5
1A	G01	71.8	75.6	80.6	85.4	88.9	94.4	91.7	90.3	84.9	98.2	98.4
1A	G11	75.4	77.2	80.9	85.4	88.0	94.2	90.9	91.5	87.4	98.2	98.5
2	G00	71.9	77.0	83.4	87.6	85.7	82.5	77.5	74.2	72.9	87.3	91.8
2	G01	71.3	76.8	83.3	88.4	86.3	93.5	86.9	85.1	79.5	95.6	96.6
2	G11	73.0	77.6	81.3	86.4	87.0	95.8	89.2	88.4	82.5	97.8	98.2
3	G00	72.8	77.4	80.0	84.8	83.5	85.7	82.7	77.2	73.8	89.1	91.3
3	G01	73.3	76.8	80.0	84.9	86.8	93.2	95.1	95.3	89.7	100.6	100.3
3	G11	74.0	78.1	80.4	86.3	87.6	94.1	97.0	96.3	90.9	102.0	101.6
4	G00	76.9	81.1	84.2	88.8	86.5	83.8	79.5	75.5	75.3	88.5	93.1
4	G01	77.0	80.9	83.4	87.8	86.6	90.0	88.8	85.8	81.4	94.5	95.7
4	G11	77.1	81.6	83.2	88.2	86.8	87.3	87.8	84.6	79.9	93.1	94.9
5	G00	72.0	77.3	75.8	81.0	84.3	82.4	87.0	79.2	73.5	90.3	91.1
5	G01	71.8	77.3	75.7	82.0	86.1	91.3	91.6	87.6	82.6	96.3	96.3
5	G11	71.5	78.4	75.8	80.8	83.9	93.2	90.2	85.7	81.6	96.2	96.2
6	G00	69.5	76.0	78.1	78.1	79.9	71.9	69.4	65.2	63.6	79.0	84.9
6	G01	69.0	75.7	78.1	78.4	78.5	81.4	77.8	75.2	70.3	84.9	87.0
6	G11	68.7	76.0	77.9	79.2	80.1	84.2	78.9	80.0	77.9	87.7	89.0
7	G00	76.4	83.0	82.9	87.1	84.5	83.3	80.0	76.6	76.4	88.1	92.2
7	G01	75.9	82.8	81.6	87.6	84.5	87.0	83.5	81.1	77.8	90.9	93.4
7	G11	76.4	82.5	82.9	87.4	85.3	88.8	84.8	81.0	78.1	92.0	94.1
8	G00	68.4	75.8	78.3	76.2	72.2	76.7	71.6	71.4	62.9	79.9	83.9
8	G01	69.2	78.1	79.3	76.4	75.5	79.2	73.4	71.6	66.4	81.8	85.6
8	G11	69.5	77.0	79.2	76.7	76.0	80.9	74.6	76.4	72.2	83.9	86.4
9	G00	71.3	78.9	81.7	79.9	79.0	79.1	75.9	77.2	72.8	84.3	87.9
9	G01	73.2	81.4	83.2	81.5	82.4	82.0	79.2	75.7	73.3	86.3	89.9
9	G11	73.1	81.2	84.0	82.6	81.8	81.9	77.4	76.0	74.1	85.9	90.1

Table 3 (continued).

Position	Condition	31.5	63	125	250	500	1000	2000	4000	8000	AWT	LIN
10	G01	76.3	80.8	81.3	82.2	78.5	89.4	78.0	74.8	70.4	89.8	91.8
10	G11	72.8	79.6	80.6	80.1	79.0	89.2	78.3	74.6	69.3	89.8	91.3
11	G01	79.8	85.6	89.1	85.2	84.9	86.1	83.9	80.9	81.6	90.7	94.6
11	G11	78.5	84.7	89.1	85.1	84.5	84.1	82.9	79.2	80.0	89.4	93.9
12	G00	73.4	82.1	84.5	84.4	81.6	80.7	78.6	76.6	77.1	86.3	90.8
12	G01	74.9	82.8	87.8	83.0	83.7	86.9	85.4	83.7	79.9	91.6	93.8
12	G11	75.6	82.1	87.0	85.0	85.6	89.3	85.1	83.0	79.7	92.5	94.5
13	G00	78.8	79.9	75.8	79.2	76.7	76.0	73.5	71.2	70.8	81.2	86.4
13	G01	81.1	82.1	81.0	80.6	79.8	80.5	78.9	75.9	72.9	85.3	89.5
13	G11	81.2	82.8	79.2	82.0	80.7	79.1	77.3	74.4	72.2	84.4	89.4
14	G00	83.1	80.5	79.3	86.6	81.7	79.3	76.1	75.1	73.3	85.3	90.8
14	G00	83.2	79.6	79.7	86.4	81.5	79.1	77.7	75.7	74.1	85.6	90.7
14	G01	83.0	80.6	80.8	87.5	81.7	80.4	81.0	76.9	74.5	87.1	91.6
14	G01	83.7	80.3	81.3	87.7	81.6	80.6	81.5	77.1	74.5	87.4	91.9
14	G11	84.1	80.6	81.4	87.3	82.3	80.9	80.6	76.7	74.2	87.1	91.9
14	G11	84.1	80.9	81.5	87.1	82.6	80.7	80.3	76.7	74.5	87.1	91.9

Table 4.

Noise levels in dB during hangar operation for the indicated positions and test conditions.

Position	Condition	31.5	63	125	250	500	1000	2000	4000	8000	AWT	LIN
1	H00	72.3	73.3	73.0	75.5	85.3	79.4	72.3	67.3	59.6	83.6	87.3
1	H01	72.0	72.8	72.6	75.1	85.4	81.9	74.2	68.1	60.8	85.1	88.0
1	H11	71.4	73.7	71.7	73.4	85.0	81.2	76.1	83.6	74.7	87.8	89.1
1A	H00	73.9	75.8	72.6	76.6	86.8	85.2	78.3	72.9	66.2	87.6	90.1
1A	H01	73.3	75.5	72.4	83.3	87.7	86.4	80.9	75.1	68.7	89.3	91.7
1A	H11	74.3	76.0	72.5	77.6	87.6	86.5	82.4	83.8	82.6	91.2	92.5
2	H00	72.5	76.0	71.4	71.8	79.0	83.0	76.3	69.6	60.9	84.3	86.2
2	H01	72.8	75.6	71.3	76.8	83.8	86.8	78.3	71.9	63.9	88.1	89.7
2	H11	72.7	76.1	72.7	73.7	83.9	86.1	84.1	89.3	77.4	92.8	92.8
3	H00	70.8	74.9	71.9	75.0	84.1	81.7	79.4	74.3	66.0	85.8	87.9
3	H01	71.1	74.7	72.3	78.5	84.8	92.4	83.4	78.3	71.4	93.0	93.9
3	H11	70.6	75.3	71.9	75.6	85.1	92.1	84.3	81.9	76.2	93.3	94.0
4	H00	70.9	75.6	71.1	72.8	82.4	83.6	75.3	70.5	63.1	85.1	87.2
4	H01	70.4	82.5	70.7	94.0	83.7	78.9	73.0	71.4	65.3	86.7	88.7
4	H11	70.2	74.6	70.8	78.5	83.9	84.4	78.8	75.2	72.6	87.1	88.8
5	H00	74.2	77.2	72.6	78.9	87.4	82.4	86.9	79.4	74.6	90.7	91.8
5	H01	73.8	77.9	72.5	78.6	86.0	85.4	87.5	80.0	74.4	91.4	92.1
5	H11	73.6	77.3	72.0	79.0	85.0	85.8	87.1	83.4	78.1	91.8	92.2
6	H00	73.2	80.9	71.7	72.1	76.6	74.8	72.4	66.4	58.3	78.8	84.4
6	H01	73.3	80.5	70.5	74.1	78.2	77.9	75.0	68.4	61.4	81.3	85.3
6	H11	72.9	81.7	70.1	72.5	78.3	80.6	74.2	78.1	73.2	84.2	86.9
7	H00	68.1	72.7	69.7	72.0	80.3	81.6	71.8	65.9	59.3	82.9	85.1
7	H01	69.0	72.1	69.0	73.6	91.2	91.6	74.6	69.2	61.9	84.1	86.3
7	H11	69.4	72.7	69.6	73.2	80.0	81.4	74.7	74.4	68.8	83.8	85.6
8	H00	67.9	76.7	72.5	71.2	74.7	77.3	73.5	70.4	60.0	80.3	83.0
8	H01	68.2	76.7	71.6	71.1	76.8	80.7	74.2	72.2	65.9	82.7	84.7
8	H11	69.1	77.2	71.9	72.1	78.1	81.1	75.1	79.7	71.7	84.9	86.3

Table 4 (continued).

Position	Condition	31.5	63	125	250	500	1000	2000	4000	8000	AWT	LIN
9	H00	72.6	74.6	70.3	71.2	77.9	79.4	72.3	71.1	63.0	81.6	84.0
9	H01	72.7	72.8	70.1	71.3	79.6	79.7	71.9	69.9	63.1	81.8	84.4
9	H11	72.4	73.6	69.8	72.5	79.0	81.1	74.1	77.4	68.2	84.1	85.6
10	H00	71.9	81.7	71.0	75.7	79.8	77.7	71.9	66.1	57.0	80.7	85.9
10	H01	71.3	81.3	72.4	77.8	81.9	87.8	78.0	73.0	67.4	88.4	90.3
10	H11	71.7	82.2	71.7	77.6	79.9	85.0	76.6	74.2	66.5	86.2	88.7
11	H00	74.7	78.2	73.2	79.6	83.3	81.6	81.2	76.7	71.3	86.8	88.8
11	H01	73.5	77.7	71.7	76.0	81.9	82.8	78.9	76.1	69.7	86.1	87.9
11	H11	72.4	77.3	72.9	79.6	84.2	82.9	79.5	76.7	70.4	86.8	88.9
12	H00	71.2	73.4	68.9	73.2	83.5	83.1	72.7	67.1	61.9	84.6	87.1
12	H01	75.8	77.2	72.7	79.8	82.9	83.8	76.6	70.3	64.7	85.7	88.5
12	H11	69.3	73.6	70.3	84.3	85.3	83.6	77.9	75.7	71.9	87.2	90.0
13	H01	75.4	78.3	71.8	75.3	84.2	76.5	73.8	67.3	61.4	82.5	86.9
13	H11	75.8	79.2	73.2	70.8	79.1	76.6	72.4	68.9	62.6	80.3	84.9
14	H00	76.8	71.3	69.1	68.6	73.1	74.2	66.5	65.6	55.9	76.3	81.2
14	H01	83.0	77.7	73.8	72.5	76.2	77.0	75.2	70.6	63.3	81.0	86.5
14	H01	78.8	74.1	73.8	72.2	75.8	77.1	75.5	70.9	64.0	81.1	84.5
14	H11	78.8	73.3	73.8	72.7	76.2	77.3	75.8	71.1	65.5	81.5	84.6
14	H11	78.6	73.9	75.0	72.9	75.7	79.5	76.7	71.8	64.9	82.6	85.3

Table 5.

Noise levels in dB during maintenance operation for the indicated positions and test conditions.

Position	Condition	31.5	63	125	250	500	1000	2000	4000	8000	ΔWT	LIN
1M	F00	69.3	60.6	61.2	59.0	54.8	53.9	53.4	48.1	36.4	59.6	71.3
1M	F01	68.5	61.7	63.4	67.2	69.4	74.6	80.6	79.8	74.0	85.0	84.6
1M	F11	68.4	62.8	63.3	67.4	70.5	78.6	87.7	85.7	78.0	91.3	90.5
2M	F00	69.7	64.3	59.0	59.1	55.0	53.9	56.8	49.9	38.5	61.0	71.9
2M	F01	70.0	63.3	64.2	66.8	66.0	73.8	79.9	85.5	73.5	87.8	87.2
2M	F11	69.2	64.1	64.1	68.9	69.4	76.3	81.8	85.9	74.8	88.7	88.0
3M	F00	68.7	64.3	59.6	58.2	55.6	54.9	55.8	50.2	41.1	60.9	71.3
3M	F01	67.4	64.4	62.0	67.2	65.2	70.4	77.7	79.8	71.3	83.4	83.0
3M	F11	68.0	63.9	62.6	67.5	68.6	72.4	78.4	82.1	75.8	85.3	84.9
4M	F00	65.7	63.1	59.7	59.2	58.4	57.2	56.2	49.9	42.8	62.2	69.9
4M	F01	65.8	63.5	61.6	65.2	69.3	70.7	74.2	82.0	71.9	84.0	83.6
4M	F11	65.3	63.0	62.1	65.8	68.9	72.6	80.5	78.8	76.7	84.8	84.4

Table 6.

Effective noise exposure level in dBA and allowable exposure time in minutes
for individuals wearing the triple flange earplug.

POSITION	CONDITION	Exposure level	Allowable exposure time
1A	A00	86.3	355.8
1A	A01	85.4	440.8
3	A11	85.7	406.3
11	A00	91.6	104.9
11	A01	91.5	106.4
11	A11	91.7	103.1

Table 7.

Effective noise exposure level in dBA and allowable exposure time in minutes
for individuals wearing the V-51R earplug.

POSITION	CONDITION	Exposure level	Allowable exposure time
11	A00	90.2	144.5
11	A01	90.0	150.7
11	A11	90.2	144.1

Table 8.

Exposure levels in dB while wearing hearing protection during APU operation.

POSITION	CONDITION	125	250	500	1000	2000	4000	8000	EEL
		Hearing Protector				<u>E-A-R</u>			
1	A00	50.4	57.7	64.4	63.8	59.8	53.5	38.1	68.5
1	A01	55.8	61.8	66.6	66.1	63.0	58.4	40.4	71.2
1	A11	50.5	58.7	65.4	67.8	64.5	61.1	47.1	71.6
1A	A00	53.9	59.9	66.7	70.8	69.1	68.0	50.2	75.1
1A	A01	54.8	61.1	66.8	76.1	71.7	64.1	51.3	78.1
1A	A11	52.8	57.9	66.6	71.1	69.6	61.3	50.3	74.6
2	A00	51.5	61.5	65.7	70.8	62.5	51.5	40.8	72.8
2	A01	52.4	61.8	66.0	69.5	62.0	52.1	40.8	72.1
2	A11	53.6	62.1	68.8	74.5	67.5	58.2	51.3	76.4
3	A00	52.9	65.1	72.7	71.3	68.1	59.5	49.6	76.3
3	A01	52.6	64.0	71.5	73.1	68.4	59.1	46.9	76.6
3	A11	55.9	67.9	73.0	75.4	69.9	61.2	51.3	78.6
4	A00	55.1	69.3	71.4	74.5	66.0	56.7	43.9	77.4
4	A01	55.7	66.2	69.8	73.9	66.3	56.6	45.0	76.4
4	A11	56.1	68.0	70.6	72.6	65.9	54.8	44.6	76.1
5	A00	53.4	60.6	64.2	71.7	67.4	55.7	49.5	73.9
5	A01	53.1	58.6	66.4	73.6	68.6	57.0	44.9	75.5
5	A11	53.2	58.9	63.9	72.0	64.8	54.5	43.9	73.6
6	A00	45.0	53.4	58.4	64.1	58.1	46.0	36.6	66.3
6	A01	46.3	53.8	56.9	60.4	57.8	48.2	36.2	64.1
6	A11	47.6	54.9	59.1	61.4	61.4	52.1	39.9	66.1
7	A00	46.2	62.2	64.1	66.1	61.2	57.2	42.6	70.1
7	A01	46.5	62.1	61.4	66.3	60.3	49.5	38.8	69.3
7	A11	46.1	59.6	62.4	65.9	59.2	53.2	40.2	68.9
8	A00	38.8	49.3	51.6	59.8	51.1	41.9	26.7	61.3
8	A01	37.4	48.8	53.6	63.6	53.8	42.4	31.0	64.6
8	A11	37.4	49.7	54.3	58.1	49.9	43.0	32.9	60.6

Table 8 (continued).

POSITION	CONDITION	125	250	500	1000	2000	4000	8000	EEL
9	A00	43.3	48.6	55.2	60.4	53.9	46.6	32.3	62.6
9	A01	41.7	51.1	57.1	58.2	54.3	43.2	31.8	62.0
9	A11	41.4	52.0	59.9	59.8	53.0	42.6	32.9	63.6
10	A00	46.2	58.4	61.4	66.4	64.3	46.7	38.0	69.7
10	A01	48.2	59.8	65.5	70.2	58.6	45.7	36.7	71.9
10	A11	43.9	57.0	61.2	68.3	60.1	45.9	36.1	69.8
11	A00	58.4	70.6	79.7	80.6	71.7	67.8	64.9	83.8
11	A01	58.9	71.5	80.6	80.1	70.8	65.6	63.1	83.9
11	A11	59.4	71.9	80.4	80.3	72.2	66.4	63.9	84.1
12	A00	47.5	56.6	61.4	66.1	65.3	54.6	39.4	69.9
12	A01	46.8	58.5	62.0	65.4	59.8	57.8	40.5	68.7
12	A11	48.3	58.0	62.1	64.8	61.3	55.0	40.5	68.5
13	A00	51.1	51.1	56.5	58.6	57.6	45.5	35.3	63.1
13	A01	49.9	49.5	56.9	58.5	53.1	52.2	31.5	62.5
13	A11	48.6	48.1	55.9	60.0	53.7	44.4	33.8	62.5
14	A00	46.5	49.5	56.6	55.2	54.7	42.5	28.6	60.9
14	A00	45.9	49.5	57.7	56.0	54.3	38.6	27.8	61.4
14	A01	44.9	55.5	57.8	58.0	56.9	40.0	31.7	63.2
14	A01	46.3	51.3	58.5	57.1	53.4	40.4	28.5	62.2
14	A11	47.1	51.7	59.5	56.2	54.3	39.4	29.1	62.5
14	A11	45.2	51.2	59.3	55.8	55.6	40.6	29.2	62.5
		Hearing Protector <u>TRIPLE FLAN</u>							
1	A00	57.1	64.6	72.7	68.9	64.0	70.6	49.4	76.4
1	A01	62.5	68.7	74.9	71.2	67.2	75.5	51.7	79.7
1	A11	57.2	65.6	73.7	72.9	68.7	78.2	58.4	80.8
1A	A00	60.6	66.8	75.0	75.9	73.3	85.1	61.5	86.3
1A	A01	61.5	68.0	75.1	81.2	75.9	81.2	62.6	85.4
1A	A11	59.5	64.8	74.9	76.2	73.8	78.4	61.6	82.3
2	A00	58.2	68.4	74.0	75.9	66.7	68.6	52.1	79.2
2	A01	59.1	68.7	74.3	74.6	66.2	69.2	52.1	78.8
2	A11	60.3	69.0	77.1	79.6	71.7	75.3	62.6	83.1

Table 8 (continued).

POSITION	CONDITION	125	250	500	1000	2000	4000	8000	EEL
3	A00	59.6	72.0	81.0	76.4	72.3	76.6	60.9	84.0
3	A01	59.3	70.9	79.8	78.2	72.6	76.2	58.2	83.7
3	A11	62.6	74.8	81.3	80.5	74.1	78.3	62.6	85.7
4	A00	61.8	76.2	79.7	79.6	70.2	73.8	55.2	84.2
4	A01	62.4	73.1	78.1	79.0	70.5	73.7	56.3	83.0
4	A11	62.8	74.9	78.9	77.7	70.1	71.9	55.9	82.9
5	A00	60.1	67.5	72.5	76.8	71.6	72.8	60.8	80.3
5	A01	59.8	65.5	74.7	78.7	72.8	74.1	56.2	81.8
5	A11	59.9	65.8	72.2	77.1	69.0	71.6	55.2	79.8
6	A00	51.7	60.3	66.7	69.2	62.3	63.1	47.9	72.6
6	A01	53.0	60.7	65.2	65.5	62.0	65.3	47.5	71.2
6	A11	54.3	61.8	67.4	66.5	65.6	69.2	51.2	73.8
7	A00	52.9	69.1	72.4	71.2	65.4	74.3	53.9	78.4
7	A01	53.2	69.0	69.7	71.4	64.5	66.6	50.1	75.9
7	A11	52.8	66.5	70.7	71.0	63.4	70.3	51.5	76.3
8	A00	45.5	56.2	59.9	64.9	55.3	59.0	38.0	67.5
8	A01	44.1	55.7	61.9	68.7	58.0	59.5	42.3	70.4
8	A11	44.1	56.6	62.6	63.2	54.1	60.1	44.2	67.6
9	A00	50.0	55.5	63.5	65.5	58.1	63.7	43.6	69.7
9	A01	48.4	58.0	65.4	63.3	58.5	60.3	43.1	69.1
9	A11	48.1	58.9	68.2	64.9	57.2	59.7	44.2	70.8
10	A00	52.9	65.3	69.7	71.5	68.5	63.8	49.3	75.6
10	A01	54.9	66.7	73.8	75.3	62.8	62.8	48.0	78.2
10	A11	50.6	63.9	69.5	73.4	64.3	63.0	47.4	75.8
11	A00	65.1	77.5	88.0	85.7	75.9	84.9	76.2	91.6
11	A01	65.6	78.4	88.9	85.2	75.0	82.7	74.4	91.5
11	A11	66.1	78.8	88.7	85.4	76.4	83.5	75.2	91.7
12	A00	54.2	63.5	69.7	71.2	69.5	71.7	50.7	76.9
12	A01	53.5	65.4	70.3	70.5	64.0	74.9	51.8	77.7
12	A11	55.0	64.9	70.4	69.9	65.5	72.1	51.8	76.4

Table 8 (continued).

POSITION	CONDITION	125	250	500	1000	2000	4000	8000	EEL
13	A00	57.8	58.0	64.8	63.7	61.8	62.6	46.6	70.0
13	A01	56.6	56.4	65.2	63.6	57.3	69.3	42.8	71.9
13	A11	55.3	55.0	64.2	65.1	57.9	61.5	45.1	69.3
14	A00	53.2	56.4	64.9	60.3	58.9	59.6	39.9	68.1
14	A00	52.6	56.4	66.0	61.1	58.5	55.7	39.1	68.4
14	A01	53.0	58.2	66.8	62.2	57.6	57.5	39.8	69.3
14	A01	51.6	62.4	66.1	63.1	61.1	57.1	43.0	69.9
14	A11	53.8	58.6	67.8	61.3	58.5	56.5	40.4	69.8
14	A11	51.9	58.1	67.6	60.9	59.8	57.7	40.5	69.7
		Hearing Protector <u>V-51R</u>							
1	A00	54.8	63.9	70.4	68.3	62.1	66.4	55.4	74.3
1	A01	60.2	68.0	72.6	70.6	65.3	71.3	57.7	77.4
1	A11	54.9	64.9	71.4	72.3	66.8	74.0	64.4	78.3
1A	A00	58.3	66.1	72.7	75.3	71.4	80.9	67.5	83.0
1A	A01	59.2	67.3	72.8	80.6	74.0	77.0	68.6	83.5
1A	A11	57.2	64.1	72.6	75.6	71.9	74.2	67.6	80.2
2	A00	55.9	67.7	71.7	75.3	64.8	64.4	58.1	77.9
2	A01	56.8	68.0	72.0	74.0	64.3	65.0	58.1	77.3
2	A11	58.0	68.3	74.8	79.0	69.8	71.1	68.6	81.7
3	A00	57.3	71.3	78.7	75.8	70.4	72.4	66.9	82.0
3	A01	57.0	70.2	77.5	77.6	70.7	72.0	64.2	81.9
3	A11	60.3	74.1	79.0	79.9	72.2	74.1	68.6	84.0
4	A00	59.5	75.5	77.4	79.0	68.3	69.6	61.2	82.7
4	A01	60.1	72.4	75.8	78.4	68.6	69.5	62.3	81.6
4	A11	60.5	74.2	76.6	77.1	68.2	67.7	61.9	81.4
5	A00	57.8	66.8	70.2	76.2	69.7	68.6	66.8	78.9
5	A01	57.5	64.8	72.4	78.1	70.9	69.9	62.2	80.4
5	A11	57.6	65.1	69.9	76.5	67.1	67.4	61.2	78.5
6	A00	49.4	59.6	64.4	68.6	60.4	58.9	53.9	71.2
6	A01	50.7	60.0	62.9	64.9	60.1	61.1	53.5	69.4
6	A11	52.0	61.1	65.1	65.9	63.7	65.0	57.2	71.6

Table 8 (continued).

POSITION	CONDITION	125	250	500	1000	2000	4000	8000	EEL
7	A00	50.6	68.4	70.1	70.6	63.5	70.1	59.9	76.3
7	A01	50.9	68.3	67.4	70.8	62.6	62.4	56.1	74.5
7	A11	50.5	65.8	68.4	70.4	61.5	66.1	57.5	74.5
8	A00	43.2	55.5	57.6	64.3	53.4	54.8	44.0	66.2
8	A01	41.8	55.0	59.6	68.1	56.1	55.3	48.3	69.3
8	A11	41.8	55.9	60.3	62.6	52.2	55.9	50.2	66.0
9	A00	47.7	54.8	61.2	64.9	56.2	59.5	49.6	67.9
9	A01	46.1	57.3	63.1	62.7	56.6	56.1	49.1	67.3
9	A11	45.8	58.2	65.9	64.3	55.3	55.5	50.2	69.0
10	A00	50.6	64.6	67.4	70.9	66.6	59.6	55.3	74.3
10	A01	52.6	66.0	71.5	74.7	60.9	58.6	54.0	77.0
10	A11	48.3	63.2	67.2	72.8	62.4	58.8	53.4	74.6
11	A00	62.8	76.8	85.7	85.1	74.0	80.7	82.2	90.2
11	A01	63.3	77.7	86.6	84.6	73.1	78.5	80.4	90.0
11	A11	63.8	78.1	86.4	84.8	74.5	79.3	81.2	90.2
12	A00	51.9	62.8	67.4	70.6	67.6	67.5	56.7	74.9
12	A01	51.2	64.7	68.0	69.9	62.1	70.7	57.8	75.2
12	A11	52.7	64.2	68.1	69.3	63.6	67.9	57.8	74.3
13	A00	55.5	57.3	62.5	63.1	59.9	58.4	52.6	68.2
13	A01	54.3	55.7	62.9	63.0	55.4	65.1	48.8	69.2
13	A11	53.0	54.3	61.9	64.5	56.0	57.3	51.1	67.7
14	A00	50.9	55.7	62.6	59.7	57.0	55.4	45.9	66.2
14	A00	50.3	55.7	63.7	60.5	56.6	51.5	45.1	66.6
14	A01	49.3	61.7	63.8	62.5	59.2	52.9	49.0	68.3
14	A01	50.7	57.5	64.5	61.6	55.7	53.3	45.8	67.5
14	A11	49.6	57.4	65.3	60.3	57.9	53.5	46.5	67.8
14	A11	51.5	57.9	65.5	60.7	56.6	52.3	46.4	67.9

Table 9.

Exposure level in dB while wearing hearing protection during AGPU operation.

POSITION	CONDITION	125	250	500	1000	2000	4000	8000	EEL
				Hearing Protector		<u>E-A-R</u>			
1	G00	34.8	48.2	57.7	65.0	62.1	50.7	38.9	67.5
1	G01	33.8	47.8	56.6	65.3	62.4	57.8	43.2	68.0
1	G11	34.7	48.0	57.3	65.3	62.0	56.2	43.5	67.8
1A	G00	34.7	47.2	55.9	62.9	64.1	53.8	39.7	67.2
1A	G01	35.2	46.5	56.0	64.0	64.6	60.7	52.7	68.6
1A	G11	38.8	48.1	56.3	64.0	63.7	60.5	51.9	68.2
2	G00	35.3	47.9	58.8	66.2	61.4	48.8	38.5	68.1
2	G01	34.7	47.7	58.7	67.0	62.0	59.8	47.9	69.2
2	G11	36.4	48.5	56.7	65.0	62.7	62.1	50.2	68.7
3	G00	36.2	48.3	55.4	63.4	59.2	52.0	43.7	65.6
3	G01	36.7	47.7	55.4	63.5	62.5	59.5	56.1	67.6
3	G11	37.4	49.0	55.8	64.9	63.3	60.4	58.0	68.7
4	G00	40.3	52.0	59.6	67.4	62.2	50.1	40.5	69.2
4	G01	40.4	51.8	58.8	66.4	62.3	56.3	49.8	68.8
4	G11	40.5	52.5	58.6	66.8	62.5	53.6	48.8	68.9
5	G00	35.4	48.2	51.2	59.6	60.0	48.7	48.0	63.5
5	G01	35.2	48.2	51.1	60.6	61.8	57.6	52.6	65.6
5	G11	34.9	49.3	51.2	59.4	59.6	59.5	51.2	64.8
6	G00	32.9	46.9	53.5	56.7	55.6	38.2	30.4	60.5
6	G01	32.4	46.6	53.5	57.0	54.2	47.7	38.8	60.4
6	G11	32.1	46.9	53.3	57.8	55.8	50.5	39.9	61.4
7	G00	39.8	53.9	58.3	65.7	60.2	49.6	41.0	67.6
7	G01	39.3	53.7	57.0	66.2	60.2	53.3	44.5	68.0
7	G11	39.8	53.4	58.3	66.0	61.0	55.1	45.8	68.1
8	G00	31.8	46.7	53.7	54.8	47.9	43.0	32.6	58.2
8	G01	32.6	49.0	54.7	55.0	51.2	45.5	34.4	59.4
8	G11	32.9	47.9	54.6	55.3	51.7	47.2	35.6	59.5
9	G00	34.7	49.8	57.1	58.5	54.7	45.4	36.9	62.2
9	G01	36.6	52.3	58.6	60.1	58.1	48.3	40.2	64.2
9	G11	36.5	52.1	59.4	61.2	57.5	48.2	38.4	64.8

Table 9 (continued).

POSITION	CONDITION	125	250	500	1000	2000	4000	8000	EEL
10	G01	39.7	51.7	56.7	60.8	54.2	55.7	39.0	63.9
10	G11	36.2	50.5	56.0	58.7	54.7	55.5	39.3	62.8
11	G01	43.2	56.5	64.5	63.8	60.6	52.4	44.9	68.5
11	G11	41.9	55.6	64.5	63.7	60.2	50.4	43.9	68.3
12	G00	36.8	53.0	59.9	63.0	57.3	47.0	39.6	65.8
12	G01	38.3	53.7	63.2	61.6	59.4	53.2	46.4	66.9
12	G11	39.0	53.0	62.4	63.6	61.3	55.6	46.1	67.7
13	G00	42.2	50.8	51.2	57.8	52.4	42.3	34.5	60.3
13	G01	44.5	53.0	56.4	59.2	55.5	46.8	39.9	62.8
13	G11	44.6	53.7	54.6	60.6	56.4	45.4	38.3	63.4
14	G00	46.5	51.4	54.7	65.2	57.4	45.6	37.1	66.4
14	G00	46.6	50.5	55.1	65.0	57.2	45.4	38.7	66.2
14	G01	46.4	51.5	56.2	66.1	57.4	46.7	42.0	67.2
14	G01	47.1	51.2	56.7	66.3	57.3	46.9	42.5	67.4
14	G11	47.5	51.5	56.8	65.9	58.0	47.2	41.6	67.2
14	G11	47.5	51.8	56.9	65.7	58.3	47.0	41.3	67.1
					Hearing Protector		TRIPLE FLANGE		
1	G00	41.5	55.1	66.0	70.1	66.3	67.8	50.2	74.0
1	G01	40.5	54.7	64.9	70.4	66.6	74.9	54.5	77.0
1	G11	41.4	54.9	65.6	70.4	66.2	73.3	54.8	76.1
1A	G00	41.4	54.1	64.2	68.0	68.3	70.9	51.0	74.5
1A	G01	41.9	53.4	64.3	69.1	68.8	77.8	64.0	79.1
1A	G11	45.5	55.0	64.6	69.1	67.9	77.6	63.2	78.9
2	G00	42.0	54.8	67.1	71.3	65.6	65.9	49.8	74.2
2	G01	41.4	54.6	67.0	72.1	66.2	76.9	59.2	78.8
2	G11	43.1	55.4	65.0	70.1	66.9	79.2	61.5	80.2
3	G00	42.9	55.2	63.7	68.5	63.4	69.1	55.0	73.1
3	G01	43.4	54.6	63.7	68.6	66.7	76.6	67.4	78.2
3	G11	44.1	55.9	64.1	70.0	67.5	77.5	69.3	79.2
4	G00	47.0	58.9	67.9	72.5	66.4	67.2	51.8	75.4
4	G01	47.1	58.7	67.1	71.5	66.5	73.4	61.1	76.8
4	G11	47.2	59.4	66.9	71.9	66.7	70.7	60.1	75.9
5	G00	42.1	55.1	59.5	64.7	64.2	65.8	59.3	70.6
5	G01	41.9	55.1	59.4	65.7	66.0	74.7	63.9	76.1
5	G11	41.6	56.2	59.5	64.5	63.8	76.6	62.5	77.4

Table 9 (continued).

POSITION	CONDITION	125	250	500	1000	2000	4000	8000	EEL
2	G00	39.7	54.1	64.8	70.7	63.7	61.7	55.8	72.8
2	G01	39.1	53.9	64.7	71.5	64.3	72.7	65.2	76.2
2	G11	40.8	54.7	62.7	69.5	65.0	75.0	67.5	77.1
3	G00	40.6	54.5	61.4	67.9	61.5	64.9	61.0	71.3
3	G01	41.1	53.9	61.4	68.0	64.8	72.4	73.4	77.0
3	G11	41.8	55.2	61.8	69.4	65.6	73.3	75.3	78.4
4	G00	44.7	58.2	65.6	71.9	64.5	63.0	57.8	74.0
4	G01	44.8	58.0	64.8	70.9	64.6	69.2	67.1	75.1
4	G11	44.9	58.7	64.6	71.3	64.8	66.5	66.1	74.6
5	G00	39.8	54.4	57.2	64.1	62.3	61.6	65.3	70.0
5	G01	39.6	54.4	57.1	65.1	64.1	70.5	69.9	74.4
5	G11	39.3	55.5	57.2	63.9	61.9	72.4	68.5	74.7
6	G00	37.3	53.1	59.5	61.2	57.9	51.1	47.7	65.1
6	G01	36.8	52.8	59.5	61.5	56.5	60.6	56.1	66.6
6	G11	36.5	53.1	59.3	62.3	58.1	63.4	57.2	67.9
7	G00	44.2	60.1	64.3	70.2	62.5	62.5	58.3	72.7
7	G01	43.7	59.9	63.0	70.7	62.5	66.2	61.8	73.5
7	G11	44.2	59.6	64.3	70.5	63.3	68.0	63.1	74.0
8	G00	36.2	52.9	59.7	59.3	50.2	55.9	49.9	64.1
8	G01	37.0	55.2	60.7	59.5	53.5	58.4	51.7	65.4
8	G11	37.3	54.1	60.6	59.8	54.0	60.1	52.9	65.8
9	G00	39.1	56.0	63.1	63.0	57.0	58.3	54.2	67.7
9	G01	41.0	58.5	64.6	64.6	60.4	61.2	57.5	69.8
9	G11	40.9	58.3	65.4	65.7	59.8	61.1	55.7	70.2
10	G01	44.1	57.9	62.7	65.3	56.5	68.6	56.3	71.5
10	G11	40.6	56.7	62.0	63.2	57.0	68.4	56.6	70.8
11	G01	47.6	62.7	70.5	68.3	62.9	65.3	62.2	74.3
11	G11	46.3	61.8	70.5	68.2	62.5	63.3	61.2	73.9
12	G00	41.2	59.2	65.9	67.5	59.6	59.9	56.9	71.1
12	G01	42.7	59.9	69.2	66.1	61.7	66.1	63.7	73.3
12	G11	43.4	59.2	68.4	68.1	63.6	68.5	63.4	74.1
13	G00	46.6	57.0	57.2	62.3	54.7	55.2	51.8	65.5
13	G01	48.9	59.2	62.4	63.7	57.8	59.7	57.2	68.5
13	G11	49.0	59.9	60.6	65.1	58.7	58.3	55.6	68.6

Table 9 (continued).

POSITION	CONDITION	125	250	500	1000	2000	4000	8000	EEL
14	G00	50.9	57.6	60.7	69.7	59.7	58.5	54.4	71.2
14	G00	51.0	56.7	61.1	69.5	59.5	58.3	56.0	71.1
14	G01	50.8	57.7	62.2	70.6	59.7	59.6	59.3	72.2
14	G01	51.5	57.4	62.7	70.8	59.6	59.8	59.8	72.4
14	G11	51.9	58.0	62.9	70.2	60.6	59.9	58.6	72.1
14	G11	51.9	57.7	62.8	70.4	60.3	60.1	58.9	72.2

Table 10.

Noise levels in dB around the AGPU at distances of 6 feet and 12 feet.

Position	31.5	63	125	250	500	1000	2000	4000	8000	AWT	LIN
1-12	73.2	80.0	80.4	84.6	75.6	74.9	71.3	66.9	65.2	80.8	87.8
1-6	75.5	80.8	80.9	84.8	80.3	76.3	72.2	68.9	66.0	82.4	88.8
2-12	74.6	78.2	76.3	81.4	76.3	76.2	69.1	66.0	63.7	80.0	85.8
2-6	76.6	79.1	78.7	83.8	78.5	78.0	73.1	69.4	68.8	82.5	87.9
3-12	76.6	77.2	79.8	83.3	76.9	76.7	71.7	65.8	64.4	81.1	87.2
3-6	78.6	78.3	83.0	85.1	80.6	80.2	76.0	70.7	70.9	84.6	89.8
4-12	76.6	77.8	79.2	84.2	78.0	77.0	71.6	67.1	66.2	81.7	87.7
4-6	79.1	78.9	82.9	86.9	82.2	81.6	76.5	71.5	70.3	85.8	90.9
5-12	77.2	79.3	80.9	86.7	81.9	77.1	73.5	68.7	66.8	83.5	89.9
5-6	80.3	81.4	86.1	90.5	85.6	80.6	77.6	74.0	72.3	87.6	93.7
6-12	75.7	79.9	80.5	84.8	81.2	79.2	76.8	74.9	74.3	85.0	89.4
6-6	78.8	81.7	84.9	88.3	84.8	82.6	81.1	78.9	80.4	88.9	93.1
7-12	76.3	81.2	82.8	86.8	82.5	80.3	80.0	75.4	78.5	86.9	91.3
7-6	79.5	83.2	86.8	90.9	87.5	82.6	83.7	80.3	82.9	90.9	95.2
8-12	74.0	80.4	81.7	84.7	82.6	77.8	78.4	75.4	76.4	85.7	90.0
8-6	76.7	81.9	82.8	87.4	83.0	80.8	78.6	73.2	74.2	86.4	91.4

Initial distribution

Commander, U.S. Army Natick Research,
Development and Engineering Center
ATTN: SATNC-MIL (Documents
Librarian)
Natick, MA 01760-5040

Library
Naval Submarine Medical Research Lab
Box 900, Naval Sub Base
Groton, CT 06349-5900

Chairman
National Transportation Safety Board
800 Independence Avenue, S.W.
Washington, DC 20594

Executive Director, U.S. Army Human
Research and Engineering Directorate
ATTN: Technical Library
Aberdeen Proving Ground, MD 21005

Commander
10th Medical Laboratory
ATTN: Audiologist
APO New York 09180

Commander
Man-Machine Integration System
Code 602
Naval Air Development Center
Warminster, PA 18974

Naval Air Development Center
Technical Information Division
Technical Support Detachment
Warminster, PA 18974

Commander
Naval Air Development Center
ATTN: Code 602-B
Warminster, PA 18974

Commanding Officer, Naval Medical
Research and Development Command
National Naval Medical Center
Bethesda, MD 20814-5044

Commanding Officer
Armstrong Laboratory
Wright-Patterson
Air Force Base, OH 45433-6573

Deputy Director, Defense Research
and Engineering
ATTN: Military Assistant
for Medical and Life Sciences
Washington, DC 20301-3080

Director
Army Audiology and Speech Center
Walter Reed Army Medical Center
Washington, DC 20307-5001

Commander, U.S. Army Research
Institute of Environmental Medicine
Natick, MA 01760

Commander/Director
U.S. Army Combat Surveillance
and Target Acquisition Lab
ATTN: SFAE-IEW-JS
Fort Monmouth, NJ 07703-5305

Director
Federal Aviation Administration
FAA Technical Center
Atlantic City, NJ 08405

Commander, U.S. Army Test
and Evaluation Command
ATTN: AMSTE-AD-H
Aberdeen Proving Ground, MD 21005

Naval Air Systems Command
Technical Air Library 950D
Room 278, Jefferson Plaza II
Department of the Navy
Washington, DC 20361

Director
U.S. Army Ballistic
Research Laboratory
ATTN: DRXBR-OD-ST Tech Reports
Aberdeen Proving Ground, MD 21005

Commander
U.S. Army Medical Research
Institute of Chemical Defense
ATTN: SGRD-UV-AO
Aberdeen Proving Ground,
MD 21010-5425

Commander
USAMRDALC
ATTN: SGRD-RMS
Fort Detrick, Frederick, MD 21702-5012

Director
Walter Reed Army Institute of Research
Washington, DC 20307-5100

HQ DA (DASG-PSP-O)
5109 Leesburg Pike
Falls Church, VA 22041-3258

Harry Diamond Laboratories
ATTN: Technical Information Branch
2800 Powder Mill Road
Adelphi, MD 20783-1197

U.S. Army Materiel Systems
Analysis Agency
ATTN: AMXSY-PA (Reports Processing)
Aberdeen Proving Ground
MD 21005-5071

U.S. Army Ordnance Center
and School Library
Simpson Hall, Building 3071
Aberdeen Proving Ground, MD 21005

U.S. Army Environmental
Hygiene Agency
ATTN: HSHB-MO-A
Aberdeen Proving Ground, MD 21010

Technical Library Chemical Research
and Development Center
Aberdeen Proving Ground, MD
21010-5423

Commander
U.S. Army Medical Research
Institute of Infectious Disease
ATTN: SGRD-UIZ-C
Fort Detrick, Frederick, MD 21702

Director, Biological
Sciences Division
Office of Naval Research
600 North Quincy Street
Arlington, VA 22217

Commander
U.S. Army Materiel Command
ATTN: AMCDE-XS
5001 Eisenhower Avenue
Alexandria, VA 22333

Commandant
U.S. Army Aviation
Logistics School ATTN: ATSQ-TDN
Fort Eustis, VA 23604

Headquarters (ATMD)
U.S. Army Training
and Doctrine Command
ATTN: ATBO-M
Fort Monroe, VA 23651

IAF Liaison Officer for Safety
USAF Safety Agency/SEFF
9750 Avenue G, SE
Kirtland Air Force Base
NM 87117-5671

Naval Aerospace Medical
Institute Library
Building 1953, Code 03L
Pensacola, FL 32508-5600

Command Surgeon
HQ USCENTCOM (CCSG)
U.S. Central Command
MacDill Air Force Base, FL 33608

Air University Library
(AUL/LSE)
Maxwell Air Force Base, AL 36112

U.S. Air Force Institute
of Technology (AFIT/LDEE)
Building 640, Area B
Wright-Patterson
Air Force Base, OH 45433

Henry L. Taylor
Director, Institute of Aviation
University of Illinois-Willard Airport
Savoy, IL 61874

Chief, National Guard Bureau
ATTN: NGB-ARS
Arlington Hall Station
111 South George Mason Drive
Arlington, VA 22204-1382

Commander
U.S. Army Aviation and Troop Command
ATTN: AMSAT-R-ES
4300 Goodfellow Bouvelard
St. Louis, MO 63120-1798

U.S. Army Aviation and Troop Command
Library and Information Center Branch
ATTN: AMSAV-DIL
4300 Goodfellow Boulevard
St. Louis, MO 63120

Federal Aviation Administration
Civil Aeromedical Institute
Library AAM-400A
P.O. Box 25082
Oklahoma City, OK 73125

Commander
U.S. Army Medical Department
and School
ATTN: Library
Fort Sam Houston, TX 78234

Commander
U.S. Army Institute of Surgical Research
ATTN: SGRD-USM
Fort Sam Houston, TX 78234-6200

AAMRL/HEX
Wright-Patterson
Air Force Base, OH 45433

Product Manager
Aviation Life Support Equipment
ATTN: SFAE-AV-LSE
4300 Goodfellow Boulevard
St. Louis, MO 63120-1798

Commander and Director
USAE Waterways Experiment Station
ATTN: CEWES-IM-MI-R,
CD Department
3909 Halls Ferry Road
Vicksburg, MS 39180-6199

Commanding Officer
Naval Biodynamics Laboratory
P.O. Box 24907
New Orleans, LA 70189-0407

Assistant Commandant
U.S. Army Field Artillery School
ATTN: Morris Swott Technical Library
Fort Sill, OK 73503-0312

Mr. Peter Seib
Human Engineering Crew Station
Box 266
Westland Helicopters Limited
Yeovil, Somerset BA20 2YB UK

U.S. Army Dugway Proving Ground
Technical Library, Building 5330
Dugway, UT 84022

U.S. Army Yuma Proving Ground
Technical Library
Yuma, AZ 85364

AFFTC Technical Library
6510 TW/TSTL
Edwards Air Force Base,
CA 93523-5000

Commander
Code 3431
Naval Weapons Center
China Lake, CA 93555

Aeromechanics Laboratory
U.S. Army Research and Technical Labs
Ames Research Center, M/S 215-1
Moffett Field, CA 94035

Sixth U.S. Army
ATTN: SMA
Presidio of San Francisco, CA 94129

Commander
U.S. Army Aeromedical Center
Fort Rucker, AL 36362

Strughold Aeromedical Library
Document Service Section
2511 Kennedy Circle
Brooks Air Force Base, TX 78235-5122

Dr. Diane Damos
Department of Human Factors
ISSM, USC
Los Angeles, CA 90089-0021

U.S. Army White Sands
Missile Range
ATTN: STEWS-IM-ST
White Sands Missile Range, NM 88002

U.S. Army Aviation Engineering
Flight Activity
ATTN: SAVTE-M (Tech Lib) Stop 217
Edwards Air Force Base, CA 93523-5000

Ms. Sandra G. Hart
Ames Research Center
MS 262-3
Moffett Field, CA 94035

Commander
USAMRDALC
ATTN: SGRD-UMZ
Fort Detrick, Frederick, MD 21702-5009

Commander
U.S. Army Health Services Command
ATTN: HSOP-SO
Fort Sam Houston, TX 78234-6000

U. S. Army Research Institute
Aviation R&D Activity
ATTN: PERI-IR
Fort Rucker, AL 36362

Commander
U.S. Army Safety Center
Fort Rucker, AL 36362

U.S. Army Aircraft Development
Test Activity
ATTN: STEBG-MP-P
Cairns Army Air Field
Fort Rucker, AL 36362

Commander
USAMRDALC
ATTN: SGRD-PLC (COL R. Gifford)
Fort Detrick, Frederick, MD 21702

TRADOC Aviation LO
Unit 21551, Box A-209-A
APO AE 09777

Netherlands Army Liaison Office
Building 602
Fort Rucker, AL 36362

British Army Liaison Office
Building 602
Fort Rucker, AL 36362

Italian Army Liaison Office
Building 602
Fort Rucker, AL 36362

Directorate of Training Development
Building 502
Fort Rucker, AL 36362

Chief
USAHEL/USAAVNC Field Office
P. O. Box 716
Fort Rucker, AL 36362-5349

Commander, U.S. Army Aviation Center
and Fort Rucker
ATTN: ATZQ-CG
Fort Rucker, AL 36362

Chief
Test & Evaluation Coordinating Board
Cairns Army Air Field
Fort Rucker, AL 36362

Canadian Army Liaison Office
Building 602
Fort Rucker, AL 36362

German Army Liaison Office
Building 602
Fort Rucker, AL 36362

French Army Liaison Office
USAAVNC (Building 602)
Fort Rucker, AL 36362-5021

Australian Army Liaison Office
Building 602
Fort Rucker, AL 36362

Dr. Garrison Rapmund
6 Burning Tree Court
Bethesda, MD 20817

Commandant, Royal Air Force
Institute of Aviation Medicine
Farnborough, Hampshire GU14 6SZ UK

Defense Technical Information
Cameron Station, Building 5
Alexandra, VA 22304-6145

Commander, U.S. Army Foreign Science
and Technology Center
AIFRTA (Davis)
220 7th Street, NE
Charlottesville, VA 22901-5396

Commander
Applied Technology Laboratory
USARTL-ATCOM
ATTN: Library, Building 401
Fort Eustis, VA 23604

Commander, U.S. Air Force
Development Test Center
101 West D Avenue, Suite 117
Eglin Air Force Base, FL 32542-5495

Aviation Medicine Clinic
TMC #22, SAAF
Fort Bragg, NC 28305

Dr. H. Dix Christensen
Bio-Medical Science Building, Room 753
Post Office Box 26901
Oklahoma City, OK 73190

Commander, U.S. Army Missile
Command
Redstone Scientific Information Center
ATTN: AMSMI-RD-CS-R
/ILL Documents
Redstone Arsenal, AL 35898

Director
Army Personnel Research Establishment
Farnborough, Hants GU14 6SZ UK

U.S. Army Research and Technology
Laboratories (AVSCOM)
Propulsion Laboratory MS 302-2
NASA Lewis Research Center
Cleveland, OH 44135

Commander
USAMRDALC
ATTN: SGRD-ZC (COL John F. Glenn)
Fort Detrick, Frederick, MD 21702-5012

Dr. Eugene S. Channing
166 Baughman's Lane
Frederick, MD 21702-4083

U.S. Army Medical Department
and School
USAMRDALC Liaison
ATTN: HSMC-FR
Fort Sam Houston, TX 78234

Dr. A. Kornfield
895 Head Street
San Francisco, CA 94132-2813

NVESD
AMSEL-RD-NV-ASID-PST
(Attn: Trang Bui)
10221 Burbeck Road
Fort Belvoir, VA 22060-5806

CA Av Med
HQ DAAC
Middle Wallop
Stockbridge, Hants S020 8DY UK

Dr. Christine Schlichting
Behavioral Sciences Department
Box 900, NAVUBASE NLON
Groton, CT 06349-5900

Commander, HQ AAC/SGPA
Aerospace Medicine Branch
162 Dodd Boulevard, Suite 100
Langley Air Force Base,
VA 23665-1995

Commander
Aviation Applied Technology Directorate
ATTN: AMSAT-R-TV
Fort Eustis, VA 23604-5577

COL Yehezkel G. Caine, MD
Surgeon General, Israel Air Force
Aeromedical Center Library
P. O. Box 02166 I.D.F.
Israel

Director
Aviation Research, Development
and Engineering Center
ATTN: AMSAT-R-Z
4300 Goodfellow Boulevard
St. Louis, MO 63120-1798

Commander
USAMRDALC
ATTN: SGRD-ZB (COL C. Fred Tyner)
Fort Detrick, Frederick, MD 21702-5012

Director
Directorate of Combat Developments
ATTN: ATZQ-CD
Building 515
Fort Rucker, AL 36362