

AD-A286 123

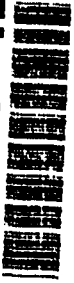

NAVAL POSTGRADUATE SCHOOL MONTEREY, CALIFORNIA



DTIC
ELECTE
NOV 14 1994
S G D

THESIS

STRATEGIC AIRLIFT ASSETS OPTIMIZATION MODEL

by

Teo-Weng Lim

September 1994

Thesis Advisor:

Richard E. Rosenthal

Approved for public release; distribution is unlimited.

94-34973



12

94 11 10 005

REPORT DOCUMENTATION PAGE

Form Approved OMB No. 0704-0188

Public reporting burden for this collection of information is estimated to average 1 hour per response, including the time for reviewing instruction, searching existing data sources, gathering and maintaining the data needed, and completing and reviewing the collection of information. Send comments regarding this burden estimate or any other aspect of this collection of information, including suggestions for reducing this burden, to Washington Headquarters Services, Directorate for Information Operations and Reports, 1215 Jefferson Davis Highway, Suite 1204, Arlington, VA 22202-4302, and to the Office of Management and Budget, Paperwork Reduction Project (0704-0188) Washington DC 20503.

1. AGENCY USE ONLY (Leave blank)		2. REPORT DATE September 1994.	3. REPORT TYPE AND DATES COVERED Master's Thesis	
4. TITLE AND SUBTITLE STRATEGIC AIRLIFT ASSETS OPTIMIZATION MODEL			5. FUNDING NUMBERS	
6. AUTHOR(S) Lim, Teo-Weng				
7. PERFORMING ORGANIZATION NAME(S) AND ADDRESS(ES) Naval Postgraduate School Monterey CA 93943-5000			8. PERFORMING ORGANIZATION REPORT NUMBER	
9. SPONSORING/MONITORING AGENCY NAME(S) AND ADDRESS(ES) USAF Studies and Analyses Agency			10. SPONSORING/MONITORING AGENCY REPORT NUMBER	
11. SUPPLEMENTARY NOTES The views expressed in this thesis are those of the author and do not reflect the official policy or position of the Department of Defense or the U.S. Government.				
12a. DISTRIBUTION/AVAILABILITY STATEMENT Approved for public release; distribution is unlimited.			12b. DISTRIBUTION CODE *A	
13. ABSTRACT (maximum 200 words) Despite the outcome of Operation Desert Shield/Storm, post-operation analysis revealed a shortcoming in USAF airlift capability. The analysis showed that early presence was not sustainable and an early Iraqi attack could have inflicted more coalition casualties. This finding prompted Congress to sponsor the Mobility Requirement Study (MRS). This thesis, sponsored by the USAF Studies and Analyses Agency, is an outgrowth of USAF and Joint Staff work for MRS. The thesis develops a multi-period Strategic Airlift Assets Optimization model using linear programming (LP), implemented with the General Algebraic Modelling System (GAMS). The model minimizes late deliveries, subject to constraints such as aircraft utilization rate and aircraft handling capacity of an airfield. This thesis demonstrates that such an LP model has sufficiently fast response time to be a viable planning tool in today's political environment, where major regional conflicts can emerge very quickly. The model can lend support to the study of military options at the planning and acquisition stages, as well as enable planners to quickly assess the impact of any shortfall in airlift capability.				
14. SUBJECT TERMS Linear Programming Optimization Model.			15. NUMBER OF PAGES *102	
			16. PRICE CODE	
17. SECURITY CLASSIFICATION OF REPORT Unclassified	18. SECURITY CLASSIFICATION OF THIS PAGE Unclassified	19. SECURITY CLASSIFICATION OF ABSTRACT Unclassified	20. LIMITATION OF ABSTRACT UL	

NSN 7540-01-280-5500

Standard Form 298 (Rev. 2-89)
Prescribed by ANSI Std. Z39-18 298-102

Approved for public release; distribution is unlimited.

STRATEGIC AIRLIFT ASSETS OPTIMIZATION MODEL

by

Teo-Weng Lim
Captain, Republic of Singapore Air Force
B.S., National University of Singapore, 1990

Submitted in partial fulfillment
of the requirements for the degree of

MASTER OF SCIENCE IN OPERATIONS RESEARCH

from the

NAVAL POSTGRADUATE SCHOOL

September 1994

Author:



Teo-Weng Lim

Approved by:



Richard E. Rosenthal, Thesis Advisor



David P. Morton, Second Reader

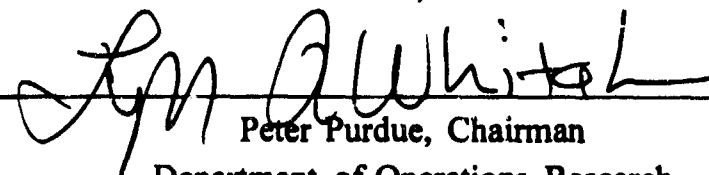

Peter Purdue, Chairman

Department of Operations Research

ABSTRACT

Despite the outcome of Operation Desert Shield/Storm, post-operation analysis revealed a shortcoming in USAF airlift capability. The analysis showed that early presence was not sustainable and an early Iraqi attack could have inflicted more coalition casualties. This finding prompted Congress to sponsor the Mobility Requirement Study (MRS). This thesis, sponsored by the USAF Studies and Analyses Agency, is an outgrowth of USAF and Joint Staff work for MRS. The thesis develops a multi-period Strategic Airlift Assets Optimization model using linear programming (LP), implemented with the General Algebraic Modelling System (GAMS). The model minimizes late deliveries, subject to constraints such as aircraft utilization rate and aircraft handling capacity of an airfield. This thesis demonstrates that such an LP model has sufficiently fast response time to be a viable planning tool in today's political environment, where major regional conflicts can emerge very quickly. The model can lend support to the study of military options at the planning and acquisition stages, as well as enable planners to quickly assess the impact of any shortfall in airlift capability.

Accession For	
NTIS CRA&I	<input checked="" type="checkbox"/>
DTIC TAB	<input type="checkbox"/>
Unannounced	<input type="checkbox"/>
Justification	
By	
Distribution /	
Availability Codes	
Dist	Avail and/or Special
A-1	

TABLE OF CONTENTS

I. INTRODUCTION	1
A. BACKGROUND	1
1. Mobility Optimization Model	2
2. Thruput Model	2
B. THESIS GOAL	3
C. PROBLEM STATEMENT	3
D. JUSTIFICATION FOR MODEL	4
II. OVERVIEW OF MODEL	5
A. MODEL FEATURES	5
B. ASSUMPTIONS	6
C. "WORD FORMULATION"	7
1. Objective Function	7
2. Constraints	7
D. DATA SOURCES, AGGREGATION AND MODEL REDUCTION .	8
1. Data Sources	8
2. Data Aggregation	9
3. Model Reduction	9

III. OPTIMIZATION MODEL	11
A. METHODOLOGY	11
B. MATHEMATICAL FORMULATION	11
1. Indices	11
2. Index Sets	12
a. Airfield Index Sets	12
b. Aircraft Index Sets	12
c. Route Index Sets	12
d. Time Index Sets	12
3. Data	12
a. Movement Requirement Data	12
b. Penalty Data	13
c. Cargo Data	13
d. Aircraft Data	13
e. Airfield Data	14
f. Aircraft Route Performance Data	14
4. Decision Variables	15
5. Objective Function	15
6. Constraints	16
a. Demand Satisfaction Constraints	16
(1) Demand Satisfaction Constraints for All Classes of Cargo.	17

(2)	Demand Satisfaction Constraints for Out-Sized Cargo.	17
(3)	Demand Satisfaction Constraints for Over-Sized Cargo.	18
(4)	Demand Satisfaction Constraints for Troops.	18
b.	Aircraft Balance Constraints	18
(1)	Aircraft Balance Constraint at Origin Airfield.	19
(2)	Balance Constraint for Aircraft Allocation.	19
(3)	Aircraft Balance Constraint at Destination Airfield.	19
c.	Aircraft Physical Limitation Constraints	20
(1)	Troop Carriage Capacity Constraints.	20
(2)	Maximum Payload Constraints.	20
(3)	Cargo Floor Space Constraints.	20
d.	Aircraft Utilization Rate Constraints	21
e.	Aircraft Handling Capacity of Airfield (MOG Constraint)	22
C.	SUMMARY	23
IV.	IMPLEMENTATION DETAILS	26
A.	ROUTE IMPLEMENTATION AND INDEX SUBSETS	26
1.	Route Implementation	26
2.	Index Subsets	27
B.	MATHEMATICAL FORMULATION	28

1.	Indices	28
2.	Data	29
a.	Movement Requirement Data	29
b.	Penalty Data	29
c.	Cargo Data	29
d.	Aircraft Data	30
e.	Airfield Data	30
f.	Aircraft Route Performance Data	30
3.	Decision Variables	31
4.	Dynamic Sets	32
a.	$DSetX(u,a,r,t)$	33
b.	$DSetY(a,r,t)$	33
5.	Objective Function	34
6.	Constraints	34
a.	Demand Satisfaction Constraints	35
(1)	Demand Satisfaction Constraints for All Classes of Cargo.	35
(2)	Demand Satisfaction Constraints for Out-Sized Cargo.	35
(3)	Demand Satisfaction Constraints for Over-Sized Cargo.	36
(4)	Demand Satisfaction Constraints for Troops.	36

b.	Aircraft Balance Constraints	36
(1)	Aircraft Balance Constraint at Origin Airfield.	36
(2)	Balance Constraint for Aircraft Allocation.	37
(3)	Aircraft Balance Constraint at Destination Airfield.	37
c.	Aircraft Physical Limitation Constraints	38
(1)	Troop Carriage Capacity Constraints.	38
(2)	Maximum Payload Constraints	38
(3)	Cargo Floor Space Constraints	38
d.	Aircraft Utilization Rate Constraints	39
e.	Aircraft Handling Capacity of Airfield (MOG Constraint)	39
V.	PERFORMANCE, ANALYTIC INSIGHTS AND LIMITATIONS	43
A.	PERFORMANCE	43
B.	ANALYTIC INSIGHTS	44
C.	MODEL LIMITATIONS	45
1.	Local Traffic Congestion	45
2.	Low Fidelity	45
VI.	CONCLUSIONS AND RECOMMENDATIONS	47
A.	CONCLUSIONS	47
B.	RECOMMENDATIONS	47
1.	Incorporate Use of Tanker Aircraft	48

2.	Increase MOG Fidelity	48
3.	Investigate the Feasibility of Improving Time Resolution	48
4.	Validate MOG Efficiency Factor	49
5.	Stochastic Modelling	49
APPENDIX A. LISTING OF DATA SOURCES		50
APPENDIX B. GAMS FORMULATION LISTING		52
LIST OF REFERENCES		87
INITIAL DISTRIBUTION LIST		88

ACKNOWLEDGEMENTS

I would like to express my sincere thanks to the following faculty members whose devotions and contributions have made this research effort such an educational, fulfilling and rewarding experience for me.

- Professor Richard E. Rosenthal for introducing me to this thesis topic and his mentoring throughout the thesis process. His optimization and modelling expertise provided the necessary background and insights to model the complex airlift system.
- Dr. David P. Morton for his dedication to this research effort. His early involvement as a second reader has greatly facilitated the thesis writing process.
- Professor Gerald G. Brown for his linear programming advice and guidance. His involvement and time spent on this thesis research is most appreciated.

I would also like to thank the following USAF personnel for assistance rendered in the course of this research.

- LTC James Hill of the Studies & Analyses Agency for allowing a foreign officer to work on a USAF project thereby contributing to international understanding and cooperation. I have gained much insight into the airlift problem as a result of this research.
- MAJ Kirk Yost of the Office of Aerospace Studies for his "reality checks" of the model. His interest and dedication on this subject matter has stimulated me greatly.
- MAJ Kevin Smith and CPT David Horton of the Studies & Analyses Agency for their assistance in gathering the necessary data required for this research.

Most importantly, I would like to dedicate this thesis to my wife Carol in recognition of her love, faith, and support throughout my career and as a student. Thank you.

EXECUTIVE SUMMARY

Despite the outcome of Operation Desert Shield/Storm, post-operation analysis revealed a shortcoming in USAF airlift capability. The analysis showed that early presence was not sustainable and an early Iraqi attack could have inflicted more coalition casualties. This finding and the desire to gain insights into the mobility system prompted Congress to sponsor the Mobility Requirement Study (MRS).

This thesis involves an optimization modelling of strategic airlift assets (aircraft and airfields) and is sponsored by the USAF Studies and Analyses Agency. It is an outgrowth of the USAF and Joint Staff work for MRS. The thesis attempts to provide insights into the strategic airlift system. Basically, it attempts to provide answers to airlift mobility questions such as, what are the system "bottle-necks" and which set of alternative strategic airlift fleets is the most effective for the scenario.

In this research, the strategic airlift assets optimization problem is formulated as a multi-commodity, multi-period network flow model with a large number of side constraints using linear programming (LP). The model, implemented on the General Algebraic Modelling System (GAMS), minimizes late deliveries subject to system constraints such as aircraft utilization rate and aircraft handling capacity of an airfield.

This optimization model can provide broad analytic insights into the strategic airlift system. For any particular set of input data, the insights gained include answers to the following mobility questions: 1) Are the assets adequate for the scenario? 2) What are the impacts of a shortfall in airlift capability? 3) What are the system "bottlenecks"?

This thesis demonstrates that such an LP model has sufficiently fast response time to be a viable planning tool in today's political environment, where major regional conflicts can emerge quickly and simultaneously. The model can lend support to the study of military options at the planning and acquisition stages, as well as enable planners to quickly assess the impact of any shortfall in airlift capability.

I. INTRODUCTION

In October 1993, the Naval Postgraduate School (NPS) Operations Research Department was formally enlisted by the United States Air Force Studies and Analyses Agency (USAF/SAA) to develop a Strategic Airlift Assets optimization model. This model would be used as a planning tool in analyzing mobility questions such as the impact of any shortfall in airlift capability for a particular major regional contingency.

A. BACKGROUND

Despite the outcome of Operation Desert Shield/Storm, post-operation analysis revealed a shortcoming in USAF airlift capability. The analysis showed that early presence was not sustainable and an early Iraqi attack could have inflicted more coalition casualties. It is for this reason that Congress commissioned a Mobility Requirement Study (MRS) in 1991. This comprehensive study examined all aspects of the mobility question, from domestic transportation to both inter-theater and intra-theater requirements.

Two linear program (LP) optimization models arose directly from the Congressionally-mandated study and form the background of this thesis. They are the Joint Staff's Force Structure Resource, and Assessment Directorate (J8)'s Mobility Optimization Model [Ref. 1] and the USAF Studies and Analyses Agency's Thruput Model [Ref. 2].

1. Mobility Optimization Model

The Mobility Optimization Model (MOM), a product of MRS, was developed by J8 with assistance from NPS within a short period of six weeks. MOM was developed to aid in determining the proper level and mix of lift assets (air and sea) necessary to support US power projection needs into the 21st century. Although MOM serves its purpose well, it is not suitable for answering the mobility questions currently sought by USAF/SAA because it does not model airlift constraints in sufficient detail; e.g., the maximum number of planes on the ground (MOG) constraint at intermediate airfields is not directly modelled. Some of MOM's technology has, however, been adopted by this thesis.

2. Thruput Model

The static Thruput optimization model was developed by USAF/SAA to help evaluate alternative military strategic airlift fleets, route structures and basing schemes for different scenarios. Although the Thruput model has proven to be useful, it has inherent limitations due to its static nature (single period). For example, important constraints such as delivery time windows cannot be modelled when the time domain is not incorporated. In addition, the model is unable to provide answers to key questions that concern decision makers such as: On what day will *unit x* commence movement and on what day will it be closed?

B. THESIS GOAL

The goal of this thesis is to develop a multi-period Strategic Airlift Assets LP optimization model using the General Algebraic Modelling System (GAMS) [Ref. 3] for the USAF. This new optimization model is an outgrowth of the USAF and Joint Staff work for MRS. It attempts to combine the best features of both models by retaining Thruput's level of system detail while incorporating MOM's treatment of the time domain. Specifically, the new model strives to provide answers to mobility questions, some of which are not available from existing models. For example:

- Are the given sets of aircraft and airfields adequate for the deployment scenario?
- If the assets are inadequate, what is the impact of the shortfall in terms of tons of equipment and number of men delivered to the theater late?
- Which of the assets (aircraft or airfield) are "bottle-necks" in the system? Is there a need to increase the number of aircraft (reserves or civilian aircraft) or a need to negotiate for access to more foreign airfields?
- Which set of alternative strategic airlift fleets is the most effective for the scenario?
- On what day will unit x commence movement and on what day will it be closed?

C. PROBLEM STATEMENT

The precise nature of the airlift problem is: Given the movement requirements for both troops and equipment for a particular scenario, and the aircraft and airfield assets available, find the optimal combination of airlift mission assignments by number and type of aircraft for each unit, routing structure, airlift mission start time and cargo type to carry. The objective of the model is to minimize penalties (weighted by each unit's

priority) for late deliveries and undelivered cargo, subject to system constraints such as bounds on aircraft utilization rates and the aircraft handling capacity of each airfield.

D. JUSTIFICATION FOR MODEL

The justifications for developing the Strategic Airlift Assets optimization model are the need to optimize and the need for quick answers.

- **Need to optimize:** With shrinking military budgets, the number of both aircraft and airfields available are set to decline. Further, the desire to have early force closure so as to reduce the vulnerability period when US forces may be outnumbered imposes great strains on the mobility system. These two factors imply that inevitably, demand will exceed supply and there is a need to optimally utilize both aircraft and airfield assets.
- **Need to have quick answers:** Today's political environment has great uncertainties in which a major regional conflict can emerge very quickly (for example Somalia). In this respect, an optimization model such as the strategic airlift model which has good turnaround time would be a viable and useful planning tool.¹ In fact, its quick turnaround time may allow the optimization model to be used in a complementary manner with other models which have different virtues; e.g., a simulation model can capture more detail but generally takes longer to run. One possible complementary mode of operation is to use the outputs of the optimization model as inputs for the simulation model, e.g., number of aircraft and airfield assets to use.

¹The current optimization model has a total response time of under 2 hrs for a typical size problem. It takes approximately an hour and a half to enter new data and the LP is generated and solved in under 2 minutes on an IBM RS6000 model 590 workstation.

II. OVERVIEW OF MODEL

This chapter gives a broad overview of pertinent features of the airlift system, modelling assumptions, and a verbal description ("word formulation") of the objective function and constraints. Also included in this chapter is a brief discussion on the origin of data sources, the need for data aggregation and model reduction techniques.

A. MODEL FEATURES

The airlift system has its own peculiar features and modes of operation. Most of these have been incorporated in the model to make it as representative of real time operation as possible. Others, such as the use of tanker aircraft for aerial refueling of airlift aircraft are recommended as follow-on work. One possible way to incorporate the use of tankers is the "airbase in the sky" concept utilized by RAND's CONOP optimization model [Ref. 4]. The major aspects of the airlift system captured by the model include:

- **Multiple origin/destination airfields (source and sink nodes):** This feature is representative of the airlift system that typically utilizes multiple origin, enroute and destination airfields. The model can facilitate the study of simultaneous major regional contingency plans.
- **Flexible routing structure:** The air route structure supported by the model includes delivery/recovery routes with zero to three enroute stops. This provision allows for use of a mixture of both short-range and long-range aircraft. It also allows the LP to choose between higher-payload, shorter-range flights (more enroute stops and more ground time) and lower-payload, longer-range flights. In addition to the variable number of enroute stops, the model also allows the same aircraft to fly different delivery and recovery routes for improved realism and efficiency.

- **Aircraft-to-route restriction:** Provisions have been made to allow the user to impose aircraft-to-route restrictions; e.g., military aircraft may use military airfields for enroute stops. This particular provision arises because Air Mobility Command (AMC) may rely on civilian airliners to augment USAF aircraft in a deployment under the Civil Reserve Airfleet (CRAF) program. It is necessary to distinguish between the USAF and CRAF aircraft because of possible route restrictions. For example, military aircraft may not be permitted to land in certain civilian airfields. The model also allows the user to route aircraft through specific recovery bases, as in AMC's typical concept of operations.
- **Aircraft assets can be added over time:** This adds realism to the model since CRAF and reserves aircraft typically take time to mobilize and are generally not available until later in the deployment.
- **Delivery time windows:** In a deployment, a unit is ready to move on a certain date and has to arrive at the theater by a specific date; i.e., there is a Time Phase Force Deployment Date (TPFDD) associated with each unit. This aspect of the problem has been incorporated in the model through user-specified dates for each unit.

B. ASSUMPTIONS

Listed below are the major assumptions made by the model. These assumptions are made due to the nature of the data available or to avoid computational intractability.

- **Inventoried aircraft at origin/destination airfields do not affect the aircraft handling capacity of the airfield:** This assumption is made in the modelling of the aircraft handling capacity constraint of each airfield. It is not strictly valid since an inventoried aircraft takes up parking space even if it is not consuming services. However, since the aircraft handling capacity figures are based on a host of other factors like material handling equipment (MHE), servicing and fuel availability, it is probably more accurate to model the problem as such. Segregation of airfield capacity data (into parking spaces and services) is necessary before the constraints can be modelled appropriately. This recommendation has been made to the USAF.
- **Deterministic ground time:** Aircraft turnaround times for onload/offload of cargo and enroute refuelling are assumed to be known constants, although they are naturally stochastic. This assumption will result in an optimistic solution from the LP as time deviations could cause some aircraft to wait on the ground while others are being serviced. The stochastic nature of ground time is however, offset

somewhat by a MOG efficiency factor introduced in the formulation to soften the impact of randomness. Further research and validation are required to assess the impact of this assumption and the offsetting technique.

- **No restriction on airfield operating hours:** The assumption that all airfields are twenty-four hour capable is included as a caveat for future modelers because an airfield may have operating hours restriction. Airfield operating hours do not affect the current model since the time resolution (in days) does not warrant a discrimination of airfield operating hours as arrivals at each airfield is rounded to the nearest day; i.e., no distinction between day and night arrival etc. Airfield operating hours may become important if the time resolution of the model is reduced to say six hour blocks.

C. "WORD FORMULATION"

This section gives a verbal description of the objective function and constraints of the Strategic Airlift Assets optimization model. Discussions on the mathematical formulation and implementation details can be found in Chapters III and IV respectively.

1. Objective Function

The purpose of the optimization model is to determine a schedule of airlift missions with troops and cargo to carry, and recovery missions, so as to minimize the total weighted penalties of late deliveries and undelivered cargo (weighted by the movement priority of a unit).

2. Constraints

The constraints of the airlift system modelled can be broadly grouped into the following categories: Demand satisfaction, aircraft balance, aircraft physical limitation, aircraft utilization rate and aircraft handling capacity of an airfield.

- **Demand Satisfaction Constraints:** Demands on the airlift system are the movement requirements for troops and cargo. The demand satisfaction constraints for troops try to ensure that the number of troops that arrive within the permitted time window for each unit is greater than the number required, with shortfalls accounted for by deviation variables that are penalized in the objective function. The demand satisfaction constraints for each unit's cargo serve the same purpose for the required equipment.
- **Aircraft Balance Constraints:** These constraints keep physical count of aircraft by type in each time period. They ensure that the aircraft assets are used only if and when they are available.
- **Aircraft Physical Limitation Constraints:** There are three different kinds of constraints on the physical limitations of aircraft. These constraints ensure that limits on troop carriage capacity, maximum payload, and cabin floor space constraints are observed at all times.
- **Aircraft Utilization Rate Constraints:** These constraints ensure that the average flying hours consumed per aircraft per day is less than AMC's established utilization rate for each aircraft type.
- **Aircraft Handling Capacity of Airfield (MOG):** These constraints ensure that the number of aircraft routed through an airfield each day can be handled by the airfield.

D. DATA SOURCES, AGGREGATION AND MODEL REDUCTION

1. Data Sources

The data inputs used in trial runs of the model to date were obtained through the assistance of USAF/SAA. Most of these data are scenario-specific and can be found in documents and planning guides.

For example, the airfields' aircraft handling capacity figures (or MOG figures) were developed by AMC for the Mobility Requirements Study and data such as

space or maximum payload of an aircraft for a particular range were obtained from aircraft technical manuals. Appendix A gives a listing of the data sources.

2. Data Aggregation

The need for data aggregation as well as efficient handling of multi-dimensional modeling entities was envisaged early during model development. For example, there is a set of decision variables with eight indices that would have over 9 millions members if all combinations are included.² This set must be reduced drastically in model implementation in order for the LP to be tractable. For this reason, the geographic and requirements data were reviewed thoroughly with USAF/SAA and aggregated whenever reasonable to do so. For example, airfields in close proximity (up to about 300 nautical miles) are collapsed into a single entity with their MOG figures aggregated, and units with similar origins, destinations and time windows are represented as aggregate movement requirements.

3. Model Reduction

In addition to data aggregation, logical conditional checks are used extensively in the model to reduce the number of decision variables. The conditional checks serve to eradicate those combination of decision variables that are known to have zero values at optimality and hence help to reduce the problem size. For a simple example, if there are no Boeing 747 aircraft (CRAF) available until day 10, then all

²The variable has one index each for unit, time period and aircraft type, and 5 indices representing airfields along a route. For a problem with 30 time periods, 20 units, 5 aircraft types and 5 members per airfield index, with all possible index combinations counted, there would be 9,375,000 variables.

airlift missions associated with the B747 fleet for the first 9 days are removed from the LP formulation. Unnecessary constraints are eliminated in a similar manner.

These logical checks and reductions are implemented in a generic fashion, so in contrast to the aggregations they do not have to be reconsidered when the user changes the data.

III. OPTIMIZATION MODEL

This chapter gives a mathematical formulation of the conceptual optimization model discussed in Chapter II. Implementation aspects of the model are covered in Chapter IV.

A. METHODOLOGY

The strategic airlift assets optimization problem is basically formulated as a multi-commodity, multi-period network flow model with a large number of side constraints. Two key concepts are employed in the model. The first key concept is the use of a time index to track the locations of aircraft for each time period. Knowing when an aircraft will arrive at a particular airfield allows the aircraft handling capacity constraint of an airfield to be modelled appropriately. The second key concept is model reduction through data aggregation and the removal of unnecessary decision variables and constraints prior to LP optimization.

B. MATHEMATICAL FORMULATION

1. Indices

u	unit; e.g., 82nd Airborne
a	aircraft type; e.g., C5, C141
t,t'	time period in days
b	generic airfield; i.e., origin, enroute and destination airfields
i	origin airfield
k	destination airfield
r	route

2. Index Sets

a. Airfield Index Sets

B set of available airfields
 $I \subseteq B$ origin airfields
 $K \subseteq B$ destination airfields

b. Aircraft Index Sets

A set of available aircraft types
 $A_{\text{bulk}} \subseteq A$ aircraft capable of hauling bulk-sized cargo
 $A_{\text{over}} \subseteq A_{\text{bulk}}$ aircraft capable of hauling over-sized cargo
 $A_{\text{out}} \subseteq A_{\text{over}}$ aircraft capable of hauling out-sized cargo

c. Route Index Sets

R set of available routes
 $R_a \subseteq R$ permissible routes for aircraft a
 $R_{ab} \subseteq R$ permissible routes for aircraft a that utilizes airfield b
 $R_{ik} \subseteq R$ permissible routes for aircraft a that connect the (i,k) origin-destination pair
 $DR_i \subseteq R$ delivery routes that originate from origin i
 $RR_k \subseteq R$ recovery routes that originate from destination k

d. Time Index Sets

T set of time periods
 $T_{uar} \subseteq T$ permissible delivery window for unit u with aircraft a and route r combination; this time window covers the period from the unit is Available-to-Load Date to the Required Delivery Date plus a maximum allowed lateness for delivery

3. Data

a. Movement Requirement Data

MovePAX_{ik} Troop movement requirement for unit u from origin i to destination k

$MoveUE_{iik}$	Equipment movement requirement in tons for unit u from origin i to destination k
$ProBulk_u$	Proportion of unit u cargo that is bulk-sized (loose cargo palletized on a 88" x 108" platform)
$ProOver_u$	Proportion of unit u cargo that is over-sized (non-palletized cargo rolling stock that can fit into a C141); over-sized cargo has a larger dimension than bulk-sized cargo
$ProOut_u$	Proportion of unit u cargo that is out-sized (non-palletized cargo that can fit into a C5 or C17 but not a C141)

b. Penalty Data

$LatePenUE_u$	Lateness penalty (per ton per day) for unit u equipment
$LatePenPAX_u$	Lateness penalty (per soldier per day) for unit u troops
$NoGoPenUE_u$	"Non-delivery" penalty (per ton) for unit u equipment
$NoGoPenPAX_u$	"Non-delivery" penalty (per soldier) for unit u troops
$MaxLate$	Maximum allowed lateness (in days) for delivery

c. Cargo Data

$UESqFt_u$	Average cargo floor space (in sq. ft.) per ton of unit u equipment
$PAXWt$	Average weight of a soldier inclusive of personal equipment

d. Aircraft Data

$Supply_a$	Additional number of aircraft a made available on day t
$MaxPAX_a$	Maximum troop carriage capacity of aircraft a
$PAXSqFt_a$	Average cargo space (in sq. ft.) consumed by a soldier for aircraft a
$ACSqFt_a$	Cargo floor space (in sq. ft.) of aircraft a

LoadEff_a	Cargo space loading efficiency for aircraft <i>a</i>
URate_a	Established utilization rate (flying hours per aircraft per day) for aircraft <i>a</i>
EffTime_t	Number of effective time periods for an aircraft that is available from time period <i>t</i> ; $\text{EffTime}_t = T - t + 1$ where <i>T</i> is the time horizon

e. Airfield Data

MOGCap_b	"Maximum On Ground" capacity for narrow-body aircraft at airfield <i>b</i>
MOGReq_{ab}	Normalized MOG requirement (to narrow-body aircraft) for aircraft <i>a</i> at airfield <i>b</i> . Normalization is required for comparison purposes since an airfield has different MOG figures for each aircraft type (body type); i.e., an airfield can accommodate different number of each type of aircraft (or combinations)
MOGEff	MOG efficiency factor; introduced as a discount factor as it is impossible to fully utilize the MOG capacity due to the stochastic nature of aircraft ground time

f. Aircraft Route Performance Data

MaxLoad_{a,r}	Maximum payload (in tons) for aircraft <i>a</i> flying route <i>r</i> .
DGTime_{abr}	Aircraft ground time (due to onload of cargo, enroute refuelling, maintenance, etc) for aircraft <i>a</i> at airfield <i>b</i> on delivery route <i>r</i>
RGTime_{abr}	Aircraft ground time taken by aircraft <i>a</i> at airfield <i>b</i> on recovery route <i>r</i>
DTime_{abr}	Cumulative time (flight time plus ground time) taken by aircraft <i>a</i> to reach airfield <i>b</i> along delivery route <i>r</i>
RTime_{abr}	Cumulative time (flight time plus ground time) taken by aircraft <i>a</i> to reach airfield <i>b</i> along recovery route <i>r</i>
FltTime_{a,r}	Total flying hours consumed by aircraft <i>a</i> on route <i>r</i>

$DaysLate_{uart}$ Number of days late (after required delivery date) in delivering unit u requirement using aircraft a flying route r with mission start time t ; $DaysLate_{uart}$ is equal to zero if the cargo/troops arrive at the destination before (or on) the required delivery date

4. Decision Variables

X_{uart} Number of aircraft a that airlift unit u , via route r with mission start time t

Y_{art} Number of aircraft a that recover from a destination airfield via route r with start time t

$Allot_{ait}$ Additional number of aircraft a available from day t that are allocated to origin i

H_{ait} Number of aircraft a inventoried at origin i , at time t

HP_{akt} Number of aircraft a inventoried at destination k , at time t

$TonsUE_{uart}$ Total tonnage of unit u equipment airlifted by aircraft a , via route r with mission start time t

$TPAX_{uart}$ Total number of unit u troops airlifted by aircraft a , via route r with mission start time t

$UENoGo_{i,k}$ Total tonnage of unit u equipment not airlifted from origin i to destination k in the prescribed time frame

$PAXNoGo_{i,k}$ Number of unit u troops that not airlifted from origin i to destination k in the prescribed time frame

5. Objective Function

The model objective is to minimize the total weighted penalties (weighted by the movement priority of a unit) for late deliveries and undelivered cargo and troops.

The objective function value, z , is given by:

Minimize $Z =$

$$\begin{aligned} & \sum_u \sum_a \sum_{r \in R_u} \sum_{t \in T_{ur}} (\text{LatePenUE}_u * \text{DaysLate}_{uarr}) * \text{TonsUE}_{uarr} \\ & + \sum_u \sum_a \sum_{r \in R_u} \sum_{t \in T_{ur}} (\text{LatePenPAX}_u * \text{DaysLate}_{uarr}) * \text{TPAX}_{uarr} \\ & + \sum_u \sum_i \sum_k (\text{NoGoPenUE}_u * \text{UENoGo}_{uik}) + (\text{NoGoPenPAX}_u * \text{PAXNoGo}_{uik}). \end{aligned}$$

There are two reasons for including a "undelivered" cargo category in the objective function. First, it allow the user to control the number of time periods. Second, it permits situations where the movement requirements cannot be fulfilled due to limited aircraft, airfields, and time horizon; i.e., it allows the LP model to produce a feasible solution even when available assets are inadequate.

Some care must be taken in determining late and non-delivery penalties to ensure that they are on a common basis of x tons of one unit versus x tons of another. In addition, the user should ensure that weights are consistent; i.e., late delivery should be preferred to non-delivery. The weights will be consistent provided a late penalty (per ton per day) is less the corresponding non-delivery penalty (per ton) divided by the maximum allowed lateness (in days) for delivery.

6. Constraints

The objective function is subject to the following constraints.

a. Demand Satisfaction Constraints

Demands on the airlift system are the movement requirements for troop and different classes of cargo (bulk, over and out-sized). There are four different kinds

of demand satisfaction constraints (one for troops and three for cargo). Three separate constraints are required for cargo due to the need to impose upper bounds on the amount of cargo that can be carried by a particular class of carrier (e.g., over-sized cargo carrier); this ensures cargo-carrier compatibility.

The demand satisfaction constraints for troops ensure that the number of troops airlifted within the permitted time window for each unit is greater than or equal to the number required, with the shortfalls accounted for in the deviation variables (PAXNoGo). The demand satisfaction constraints for each unit's cargo serve the same purpose for the required equipment. The demand satisfaction constraints follow:

(1) *Demand Satisfaction Constraints for All Classes of Cargo.* For each unit and associated origin-destination pair, the total tonnage of unit equipment delivered to the theater by all aircraft types (over all permissible aircraft, route and mission start time combination) plus total tonnage not delivered (UENoGo) must be greater than or equal to the movement requirement for equipment:

$$\sum_{a \in A_{uik}} \sum_{r \in R_{uik}} \sum_{t \in T_{uik}} \text{TonsUE}_{uik} + \text{UENoGo}_{uik} \geq \text{MoveUE}_{uik} \quad \forall u, i, k : \text{MoveUE}_{uik} > 0.$$

(2) *Demand Satisfaction Constraints for Out-Sized Cargo.* For each unit and associated origin-destination pair, the total tonnage of unit equipment carried by out-sized cargo capable aircraft plus the total tonnage not delivered must be greater than or equal to the movement requirement for out-sized cargo (given by proportion of out-sized cargo multiplied by movement requirement for equipment):

$$\sum_{a \in A_{out}} \sum_{r \in R_{uik}} \sum_{t \in T_{uik}} TonsUE_{uairt} + UENoGo_{uik} \geq ProOut_u * MoveUE_{uik}$$

$$\forall u, i, k : MoveUE_{uik} > 0.$$

(3) *Demand Satisfaction Constraints for Over-Sized Cargo.* For each unit and associated origin-destination pair, the total tonnage of unit equipment carried by over-sized cargo capable aircraft plus the total tonnage not delivered must be greater than or equal to the movement requirement for over-sized and out-sized cargo:

$$\sum_{a \in A_{ovr}} \sum_{r \in R_{uik}} \sum_{t \in T_{uik}} TonsUE_{uairt} + UENoGo_{uik} \geq (ProOver_u + ProOut_u) * MoveUE_{uik}$$

$$\forall u, i, k : MoveUE_{uik} > 0.$$

The right-hand-side of the constraint is valid because out-sized cargo capable carriers are also over-sized cargo capable.

(4) *Demand Satisfaction Constraints for Troops.* For each unit and associated origin-destination pair, the total number of troops airlifted to the theater plus those not airlifted must be greater than or equal to the movement requirement for troops:

$$\sum_a \sum_{r \in R_{uik}} \sum_{t \in T_{uik}} TPAX_{uairt} + PAXNoGo_{uik} \geq MovePAX_{uik} \quad \forall u, i, k : MovePAX_{uik} > 0.$$

b. *Aircraft Balance Constraints*

The number of aircraft a assigned for airlift missions (or to be recovered from a destination airfield) must be no more than the number of aircraft a available for use. The three different kinds of aircraft balance constraints are:

(1) *Aircraft Balance Constraint at Origin Airfield.* For each aircraft a , origin i and time period t combination, the total number of aircraft assigned for airlift missions, plus those inventoried for later use must be equal to the total number of aircraft available from the previous period plus new supply of aircraft allocated to the origin and returns from previous missions:

$$\sum_a \sum_{r \in DR_i} X_{uar} + H_{ait} = H_{ait(t-1)} + Allot_{ait} + \sum_{r \in R_a} \sum_{t' + RTIME_{ar} = t} Y_{art'} \quad \forall a, i, t.$$

Note: $H_{ait(t-1)}$ is only defined for t greater than 1.
 X_{uar} is only defined for $t \in T_{uar}$.

(2) *Balance Constraint for Aircraft Allocation.* The total number of aircraft a allocated to the different origin airfields in each time period t must not be greater than the new supply of aircraft a . This constraint is incorporated in the model as it is more efficient for the LP model to distribute the new supply of aircraft than for a user to predetermine the allocation:

$$\sum_i Allot_{ait} \leq Supply_{at} \quad \forall a, t : Supply_{at} > 0.$$

(3) *Aircraft Balance Constraint at Destination Airfield.* For each aircraft a , destination k and time period t combination, the total number of aircraft a recovering from the destination airfield this period plus those that are to be inventoried must be equal to those waiting to return (inventory from last period) plus new arrivals at the destination:

$$\sum_{r \in RR_k} Y_{art} + HP_{akt} = HP_{ak(t-1)} + \sum_u \sum_{r \in R_a} \sum_{\substack{t' \in T_{uar} \\ t' - DTime_{ar} = t}} X_{uar't'} \quad \forall a, k, t.$$

Note: $HP_{ak(t-1)}$ is only defined for t greater than 1.

c. **Aircraft Physical Limitation Constraints**

There are three different kinds of constraints on the physical limitations of aircraft. These constraints ensure that limits on troop carriage capacity, maximum payload, and cargo floor space are observed.

(1) **Troop Carriage Capacity Constraints.** The total number of troops airlifted for each unit u , aircraft a , route r , and mission start time t combination must not be greater than the troop carriage capacity of aircraft a multiplied by the number of aircraft a assigned:

$$TPAX_{uar} \leq MaxPAX_a * X_{uar} \quad \forall u, a, r, t : t \in T_{uar}.$$

(2) **Maximum Payload Constraints.** The total payload (equipment and troops) airlifted for each unit u , aircraft a , route r , and mission start time t combination must not be greater than the maximum payload for aircraft a flying route r , multiplied by the number of aircraft a assigned:

$$TonsUE_{uar} + (PAXWt * TPAX_{uar}) \leq MaxLoad_{ar} * X_{uar} \quad \forall u, a, r, t : t \in T_{uar}.$$

(3) **Cargo Floor Space Constraints.** The total floor space taken up by troop and equipment for each unit u , aircraft a , route r , and mission start time t

combination must not be greater than the aircraft cargo floor space multiplied by the loading efficiency factor and number of aircraft a assigned:

$$(PAXSqFt_a * TPAX_{uart}) + (UESqFt_a * TonsUE_{uart}) \leq ACSqFt_a * LoadEff_a * X_{uart}$$

$$\forall u, a, r, t : t \in T_{uar}$$

d. Aircraft Utilization Rate Constraints

These constraints ensure that the average flying hours consumed per aircraft per day is less than AMC's established utilization rate for each aircraft type; the upper bounds for aircraft utilization is designed to capture spares availability, aircraft reliability, crew availability, etc.

Aircraft utilization rate constraints are modelled by comparing the actual flying hours consumed by an aircraft fleet in a deployment with the maximum achievable flying hours for the fleet based on the utilization rate. The total flying hours consumed by an aircraft fleet in a deployment is equal to the total flying hours consumed for both delivery and recovery routes. The maximum achievable flying hours is given by the utilization rate multiplied by the productive time periods of each available aircraft.

$$\sum_u \sum_{r \in R_a} \sum_{t \in T_{uar}} (FltTime_{ar} * X_{uart}) + \sum_{r \in R_a} \sum_t (FltTime_{ar} * Y_{art})$$

$$\leq \sum_{t: Supply_a > 0} URate_a * EffTime_t * Supply_{at} \quad \forall a.$$

As a simple illustration for the above equation, consider a fleet of 5 aircraft made available from day 11. If the utilization rate for this aircraft type is 10 flying hours per aircraft per day and the time window of concern is 30 days, then the

maximum achievable flying hours for the aircraft type over the time period is 1000 (10 x 20 x 5). This total must not be exceeded by the actual flying hours consumed by the aircraft fleet over the same period.

e. Aircraft Handling Capacity of Airfield (MOG Constraint)

These constraints model the aircraft handling capacity or throughput of each airfield. They ensure that the LP does not route more aircraft through an airfield than it can handle each day.

The maximum number of aircraft an airfield can handle each day depends on the following factors: MOG capacity of the airfield which gives the maximum number of aircraft it can accommodate at any one time, aircraft body type (narrow-body, wide-body, etc) and the amount of time each aircraft spends at the airfield.

Aircraft handling capacity constraints are modelled by computing the total MOG consumed (normalized to that of a narrow-body aircraft) in each period by each individual aircraft using the airfield. This total should not exceed the normalized MOG capacity of the airfield discounted by a MOG efficiency factor. The MOG efficiency factor is introduced as the stochastic nature of aircraft ground time implies that it is impossible to fully utilize the airfield. It is recognized that deviations from scheduled ground times can cause some aircraft to wait on the ground (or conceivably in the air) while others are being serviced. The MOG consumed by an aircraft is equal to its normalized MOG requirement multiplied by the ratio of time spent (in hours) under service to number of hours in a time period. The equation follows:

$$\begin{aligned}
& \sum_k \sum_a \sum_{r \in R_a} \sum_{\substack{i' \in T_{abr} \\ i' \cdot DTime_{abr} = t}} (MOGReq_{ab} * DTime_{abr} / 24) * X_{airt'} \\
+ & \sum_a \sum_{r \in R_a} \sum_{i' \cdot RTime_{abr} = t} (MOGReq_{ab} * RTime_{abr} / 24) * Y_{airt'} \\
& \leq MOGEff * MOGCap_b \quad \forall b, t.
\end{aligned}$$

As a simple illustration for the MOG constraint, consider the case of an airfield that can handle 10 narrow-body aircraft at a time and a MOG efficiency factor of 0.8. If each narrow-body aircraft spends 3 hours on the ground, then over the whole period (day), the airfield would be able to handle 64 narrow-body aircraft; i.e., as the equation implies $1 \times 3/24 \times 64 = 0.8 \times 10$.

An assumption made in the above formulation is that aircraft inventoried at origin or destination airfields do not consume any MOG capacity. This is not strictly valid since inventoried aircraft take up parking space. However, since MOG figures are based on a host of other factors beside parking spaces, it is probably more accurate to model the problem as such. As noted in the Assumptions section in Chapter II, if the USAF could provide separate data for "parking space MOG" and "ground services MOG", a more accurate modelling approach would be possible.

C. SUMMARY

The mathematical expressions for the objective function and constraints are summarized below:

• Objective Function

Minimize Z =

$$\begin{aligned} & \sum_u \sum_a \sum_{r \in R_u} \sum_{t \in T_{ur}} (\text{LatePenUE}_u * \text{DaysLate}_{uart}) * \text{TonsUE}_{uart} \\ & + \sum_u \sum_a \sum_{r \in R_u} \sum_{t \in T_{ur}} (\text{LatePenPAX}_u * \text{DaysLate}_{uart}) * \text{TPAX}_{uart} \\ & + \sum_u \sum_i \sum_k (\text{NoGoPenUE}_u * \text{UENoGo}_{uik}) + (\text{NoGoPenPAX}_u * \text{PAXNoGo}_{uik}). \end{aligned}$$

• Constraints

$$\sum_{a \in A_{uik}} \sum_{r \in R_{uik}} \sum_{t \in T_{ur}} \text{TonsUE}_{uart} + \text{UENoGo}_{uik} \geq \text{MoveUE}_{uik} \quad \forall u, i, k : \text{MoveUE}_{uik} > 0$$

$$\sum_{a \in A_{out}} \sum_{r \in R_{uik}} \sum_{t \in T_{ur}} \text{TonsUE}_{uart} + \text{UENoGo}_{uik} \geq \text{ProOut}_u * \text{MoveUE}_{uik}$$

$$\forall u, i, k : \text{MoveUE}_{uik} > 0$$

$$\sum_{a \in A_{ovr}} \sum_{r \in R_{uik}} \sum_{t \in T_{ur}} \text{TonsUE}_{uart} + \text{UENoGo}_{uik} \geq (\text{ProOver}_u + \text{ProOut}_u) * \text{MoveUE}_{uik}$$

$$\forall u, i, k : \text{MoveUE}_{uik} > 0$$

$$\sum_a \sum_{r \in R_{uik}} \sum_{t \in T_{ur}} \text{TPAX}_{uart} + \text{PAXNoGo}_{uik} \geq \text{MovePAX}_{uik} \quad \forall u, i, k : \text{MovePAX}_{uik} > 0$$

$$\sum_u \sum_{r \in DR_t} X_{uart} + H_{ait} = H_{ai(t-1)} + \text{Allot}_{ait} + \sum_{r \in R_u} \sum_{t' \in RTIME_{ur} = t} Y_{art'} \quad \forall a, i, t$$

$$\sum_i \text{Allot}_{ait} \leq \text{Supply}_{at} \quad \forall a,t : \text{Supply}_{at} > 0$$

$$\sum_{r \in R_k} Y_{art} + \text{HP}_{akt} = \text{HP}_{ak(t-1)} + \sum_u \sum_{r \in R_u} \sum_{\substack{T' \in T_{uar} \\ t' - D\text{Time}_{ar} = t}} X_{uarr'} \quad \forall a,k,t$$

$$\text{TPAX}_{uarr} \leq \text{MaxPAX}_a * X_{uarr} \quad \forall u,a,r,t : t \in T_{uar}$$

$$\text{TonsUE}_{uarr} + (\text{PAXWt} * \text{TPAX}_{uarr}) \leq \text{MaxLoad}_{ar} * X_{uarr} \quad \forall u,a,r,t : t \in T_{uar}$$

$$(\text{PAXSqFt}_a * \text{TPAX}_{uarr}) + (\text{UESqFt}_u * \text{TonsUE}_{uarr}) \leq \text{ACSqFt}_a * \text{LoadEff}_a * X_{uarr} \\ \forall u,a,r,t : t \in T_{uar}$$

$$\sum_u \sum_{r \in R_u} \sum_{t \in T_{uar}} (\text{FltTime}_{ar} * X_{uarr}) + \sum_{r \in R_a} \sum_t (\text{FltTime}_{ar} * Y_{art}) \\ \leq \sum_{t: \text{Supply}_{at} > 0} \text{URate}_a * \text{EffTime}_t * \text{Supply}_{at} \quad \forall a$$

$$\sum_u \sum_a \sum_{r \in R_u} \sum_{\substack{T' \in T_{uar} \\ t' - D\text{Time}_{ar} = t}} (\text{MOGReq}_{ab} * \text{DGTime}_{abr} / 24) * X_{uarr'} \\ + \sum_a \sum_{r \in R_u} \sum_{t' - R\text{Time}_{abr} = t} (\text{MOGReq}_{ab} * \text{RGTime}_{abr} / 24) * Y_{art'} \\ \leq \text{MOGEff} * \text{MOGCap}_b \quad \forall b,t$$

$$X_{uarr}, Y_{art}, \text{Allot}_{ait}, H_{ait}, \text{HP}_{akt}, \text{TonsUE}_{uarr}, \text{TPAX}_{uarr}, \text{UENoGo}_{uik}, \text{PAXNoGo}_{uik} \geq 0 \\ \forall u,a,r,t,i,k$$

IV. IMPLEMENTATION DETAILS

This chapter discusses the General Algebraic Modelling System (GAMS) implementation of the conceptual optimization model described in Chapter III and can be skipped without any loss in continuity. The materials of this chapter include key implementation features, and a mathematical formulation of the implemented model.

A. ROUTE IMPLEMENTATION AND INDEX SUBSETS

The data structures used to implement air route structure and index subsets facilitate minimal external data processing.

1. Route Implementation

The air route structure of the optimization model is represented by five indices as opposed to a single index as described in the conceptual model. These five indices represent the origin, destination and three enroute airfields. The use of five airfield indices enable the model to distinguish the origin, enroute, and destination airfields and thus allows aircraft flight times and ground times to be calculated more easily. A graphical illustration of the air route structure is shown in Figure 1 (characters in the circular nodes are airfield GEOLOC codes).

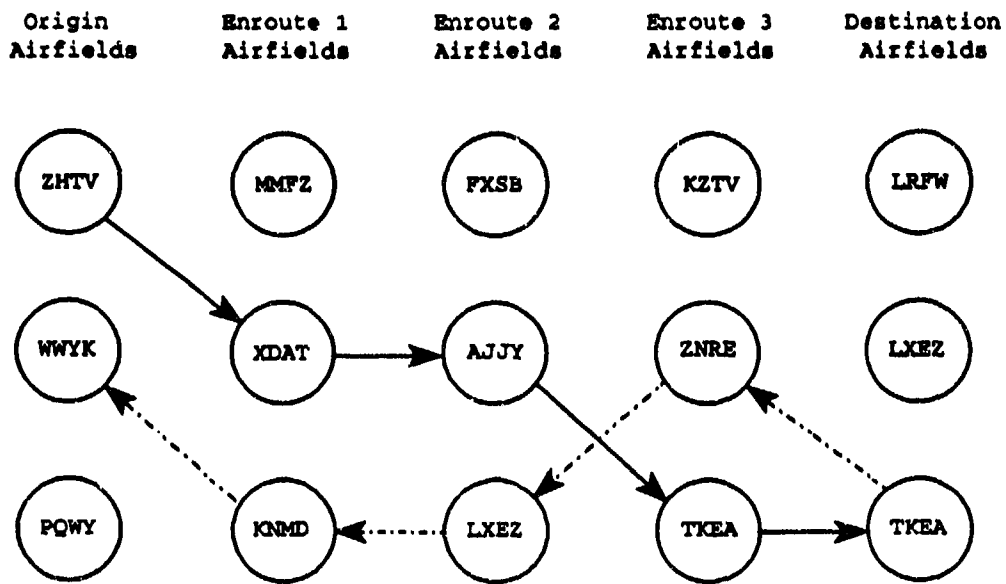

Figure 1. Air Route Structure

Although three indices are used to denote enroute stops, this does not imply that a delivery or recovery route must have three enroute stops. In fact, the model supports delivery/recovery routes with zero to three enroute stops. Routes with less than three enroute stops are implemented by replacing the non-existent enroute airfield names with the destination airfield name; e.g., the delivery route shown in Figure 1 has two enroute stops.

2. Index Subsets

Some of the index subsets of the conceptual model described in the previous chapter are not explicitly declared as a subset in the implemented model; i.e., they are not index subsets per se. Instead, these virtual index subsets are derived from the main index set through logical conditional checks performed by GAMS in model generation.

For example, the permitted delivery time window for each unit (a virtual subset) is generated by the model using relevant data such as the unit available load date, the required delivery date, and the time taken by an aircraft type to deliver the cargo. The generation of these induced virtual index subsets will become apparent in the objective function and constraint equations described below.

B. MATHEMATICAL FORMULATION

The mathematical formulation of the optimization model as implemented in GAMS is given below. To facilitate a concise discussion, only index and data sets explicit in the objective function or constraints will be described. The interested reader can refer to the GAMS formulation in Appendix B for additional detail.

1. Indices

u	unit; e.g., 82nd airborne
a	aircraft type; e.g., C5, C141
ab	aircraft body type; e.g., wide-body (wb), narrow-body (nb)
ga	ground activity; e.g., load (onld), off-load (offld), enroute (enr) turnaround
t, tp	time period in days
c	cargo type; e.g., unit equipment (UE), troops (PAX)
cc	cargo class; e.g., bulk, over or out-sized cargo
af, afp	generic airfield
i	origin airfield; $I \subseteq AF$
k	destination airfield in the theater; $K \subseteq AF$
e1	first enroute airfield; $E1 \subseteq AF$
e2	second enroute airfield; $E2 \subseteq AF$
e3	third enroute airfield; $E3 \subseteq AF$

Note: A compound index r will be used as a compact notation to represent the airfield indices (i,k,e1,e2,e3) in later discussions whenever appropriate.

2. Data

a. Movement Requirement Data

MovePAX(u, i, k)	Troop movement requirement (in 100s) for unit u from origin i to destination k
MoveJE(u, i, k)	Equipment movement requirement (in 100 tons) for unit u from origin i to destination k
CargoP(u, cc)	Proportion of cargo classes (bulk, over, out) of unit u
ALD(u)	Available load date for unit u
RDD(u)	Required delivery date for unit u

b. Penalty Data

LatePen(u, c)	Lateness penalty for cargo type c of unit u . LatePen for troops is measured in terms of per 100 PAX per day and for equipment is in terms of per 100 ton per day.
NoGoPen(u, c)	Non-delivery penalty for cargo type c of unit u . NoGoPen for troops is measured in terms of per 100 PAX and for equipment is in terms of per 100 ton.
MaxLate	Maximum allowed lateness for delivery. This maximum lateness is necessary both for controlling the size of the time domain and to allow the LP to produce a feasible solution even when assets are inadequate.

c. Cargo Data

UESqFt(u)	Average cargo space (in 1000 sq. ft.) taken up by 100 tons of unit u 's equipment
PAXWt	Average weight (in 100 tons) of 100 troops inclusive of personal equipment

d. Aircraft Data

Supply(a,t)	Additional number of aircraft <i>a</i> made available on day <i>t</i>
ACCargo(a,cc)	Aircraft-cargo class matching table; a value of '1' indicates compatibility
MaxPAX(a)	Maximum troop carriage capacity (in 100s) of aircraft <i>a</i>
PAXSqFt(a)	Average cargo space (in 1000 sq. ft.) consumed by 100 soldiers for aircraft <i>a</i>
ACSqFt(a)	Cargo floor space (in 1000 sq. ft.) of aircraft <i>a</i>
LoadEff(a)	Cargo space loading efficiency for aircraft <i>a</i>
GTime(a,ga)	Ground time required to accomplish ground activity <i>ga</i> for aircraft <i>a</i>
URate(a)	Established utilization rate (in 100 flying hours per aircraft per day) for aircraft <i>a</i>

e. Airfield Data

MOGCap(af,"nb")	"Maximum On Ground" capacity for narrow-body aircraft at airfield <i>af</i>
MOGReq(af,a)	Normalized MOG requirement (to narrow-body aircraft) for aircraft <i>a</i> at airfield <i>af</i>
MOGEff	MOG efficiency factor; introduced as a discount factor as it is impossible to fully utilize the MOG capacity due to the stochastic nature of aircraft ground time
Dist(af,afp)	Distance (in nautical miles) between airfields <i>af</i> and <i>afp</i>

f. Aircraft Route Performance Data

MaxLoad(a,r)	Maximum payload (in 100 tons) for aircraft <i>a</i> flying on route <i>r</i>
--------------	--

$CT_{toE1}(a,r)$	Cumulative time (in hrs) taken by aircraft a flying on delivery route r to reach enroute $e1$. This cumulative time includes both flying time and ground time.
$CT_{toE2}(a,r)$	Cumulative time (in hrs) taken by aircraft a flying on delivery route r to reach enroute $e2$
$CT_{toE3}(a,r)$	Cumulative time (in hrs) taken by aircraft a flying on delivery route r to reach enroute $e3$
$CT_{toK}(a,r)$	Cumulative time (in hrs) taken by aircraft a flying on delivery route r to reach destination airfield k
$RCT_{toE3}(a,r)$	Cumulative time (in hrs) taken by aircraft a flying on recovery route r to reach enroute $e3$
$RCT_{toE2}(a,r)$	Cumulative time (in hrs) taken by aircraft a flying on recovery route r to reach enroute $e2$
$RCT_{toE1}(a,r)$	Cumulative time (in hrs) taken by aircraft a flying on recovery route r to reach enroute $e1$
$RCT_{toI}(a,r)$	Cumulative time (in hrs) taken by aircraft a flying on recovery route r to reach origin i
$FltTime(a,r)$	Total flight time (in 100 hrs) consumed by aircraft a flying on route r ; excludes ground time
$VRouteX(a,r)$	A dynamic set with members indicating aircraft-delivery route compatibility. This set is used to control aircraft routing; e.g., military aircraft fly military routes and civilian aircraft fly civilian routes.
$VRouteY(a,r)$	A dynamic set with members indicating aircraft-recovery route compatibility

3. Decision Variables

$X(u,a,r,t)$	Number of aircraft a assigned to airlift unit u , via route r with mission start time t . An aircraft is permitted to carry only a single unit's cargo and troops as in a typical airlift mission
--------------	---

$Y(a,r,t)$	Number of aircraft a that recover from a destination airfield via route r with start time t
$Allot(a,i,t)$	Additional number of aircraft a available from day t that are allocated to origin i
$H(a,i,t)$	Number of aircraft a inventoried at origin i at time t
$HP(a,k,t)$	Number of aircraft a inventoried at destination k at time t
$TonsUE(u,a,r,t)$	Total tonnage (in 100 tons) of unit u equipment airlifted by aircraft a , via route r with mission start time t
$TFAX(u,a,r,t)$	Total number of unit u troops airlifted by aircraft a via route r with mission start time t
$UENoGo(u,i,k)$	Total tonnage (in 100 tons) of unit u equipment not airlifted from origin i to destination k in the prescribed time frame
$PAXNoGo(u,i,k)$	Number of unit u troops (in 100s) not airlifted from origin i to destination k in the prescribed time frame

4. Dynamic Sets

Two dynamic sets, $DSetX(u,a,r,t)$ and $DSetY(a,r,t)$, are used repeatedly throughout the formulation of the objective and constraint equations to reduce the number of decision variables and thus the size of the LP.

The dynamic sets serve two purposes. First, they control the allowable combination of unit u , aircraft a , route r and mission start time t for airlift missions. Second, the dynamic sets eradicate certain combinations of decision variables that are known to have zero values at optimality; i.e., instead of keeping these decision variables in the LP model and letting the optimizer drive them to zero, these decision variables are removed from the model formulation.

a. $DSetX(u,a,r,t)$

$DSetX(u,a,r,t)$ is used to control the valid combination of unit u , aircraft a , route r and mission start time t for the following decision variables: $X(u,a,r,t)$, $TonsUE(u,a,r,t)$ and $TPAX(u,a,r,t)$. For a combination to be valid, it must satisfy the following conditions:

- Mission start time t must satisfy the following two inequalities: $t \geq ALD(u)$ and $t \leq RDD(u) - [CTToK(a,r)/24] + MaxLate$; i.e., an unit can only be airlifted if it is ready to move and that the cargo will reach its destination before the required delivery date plus the maximum allowed lateness. Square brackets denote a "round operator"; e.g., $[3.7] = 4$ and $[3.4] = 3$
- There is movement requirement for unit u from origin airfield i to destination airfield k ; i.e., $MoveUE(u,i,k) > 0$ or $MovePAX(u,i,k) > 0$
- Be a member of $VRouteX(a,r)$; i.e., permitted aircraft-delivery route combination
- A particular aircraft-route combination is to be considered only if the permissible payload for the aircraft is at least 25 percent of the aircraft full load capability. This 25 percent factor is for cost efficiency and is also representative of real airlift operations.
- Supply of aircraft type up to time t is greater than zero

b. $DSetY(a,r,t)$

$DSetY(a,r,t)$ is used to control the valid combination of aircraft a , route r and start time t for the recovery decision variable $Y(a,r,t)$. For a combination to be valid, it must satisfy the following conditions:

- Be a member of $VRouteY(a,r)$; i.e., permitted aircraft-recovery route combination
- Supply of aircraft type up to time t is greater than zero

5. Objective Function

The model objective is to minimize the total weighted penalties (weighted by the movement priority of a unit) for late deliveries and undelivered cargo and troops.

The objective function, z , is given by:

Minimize $Z =$

$$\begin{aligned} & \sum_u \sum_a \sum_r \sum_{t \in DSerX(u,a,r,t)} \\ & \quad (LatePen(u, "UE") * Max(0, (t + [CTtoK(a,r)]/24) - RDD(u))) * TonsUE(u,a,r,t) \\ & \quad + (LatePen(u, "PAX") * Max(0, (t + [CTtoK(a,r)]/24) - RDD(u))) * TPAX(u,a,r,t) \\ & + \sum_u \sum_i \sum_{k: MoveUE(u,i,k) > 0 \text{ or } MovePAX(u,i,k) > 0} \\ & \quad (NoGoPen(u, "UE") * UENoGo(u,i,k)) + (NoGoPen(u, "PAX") * PAXNoGo(u,i,k)). \end{aligned}$$

$$Note: \sum_r = \sum_i \sum_k \sum_{e1} \sum_{e2} \sum_{e3}$$

The number of days late in delivery for a particular unit u , aircraft a , route r and mission start time t combination is given by the GAMS function $Max(a,b)$ where a and b are numerical values or arithmetic expressions. For cargo and troops delivered to the theater on or before the required delivery date no penalty is incurred. For cargo and troops delivered late, the number of days late in delivery is equal to the mission start time plus time taken by the aircraft to deliver the cargo and troops minus the required delivery date.

6. Constraints

The objective function is subject to the following constraints.

a. Demand Satisfaction Constraints

The constraints for satisfying demand are the requirements for troops and the different classes of cargo (bulk, over and out-sized). There are four different kinds of demand satisfaction constraints (one for troops and three for cargo). Three separate constraints are required for cargo due to the need to ensure aircraft-cargo compatibility. The demand satisfaction constraints follow:

(1) *Demand Satisfaction Constraints for All Classes of Cargo.* For each unit and associated origin-destination pair, the total tonnage of unit equipment delivered to the theater by all aircraft types (over all permissible route and mission start time combination) plus total tonnage not delivered (UENoGo) must be greater than or equal to the movement requirement for equipment:

$$\sum_{a: ACCargo(a, "bulk") > 0} \sum_{e1} \sum_{e2} \sum_{e3} \sum_{t \in DSetX(u, a, r, t)} TonsUE(u, a, r, t) + UENoGo(u, i, k) \geq MoveUE(u, i, k) \quad \forall u, i, k : MoveUE(u, i, k) > 0.$$

(2) *Demand Satisfaction Constraints for Out-Sized Cargo.* For each unit and associated origin-destination pair, the total tonnage of unit equipment carried by out-sized cargo capable aircraft plus the total tonnage not delivered must be greater than or equal to the movement requirement for out-sized cargo (given by proportion of out-sized cargo multiplied by movement requirement for equipment):

$$\sum_{a: ACCargo(a, "out") > 0} \sum_{e1} \sum_{e2} \sum_{e3} \sum_{t \in DSetX(u, a, r, t)} TonsUE(u, a, r, t) + UENoGo(u, i, k) \geq CargoP(u, "out") * MoveUE(u, i, k) \quad \forall u, i, k : MoveUE(u, i, k) > 0.$$

(3) *Demand Satisfaction Constraints for Over-Sized Cargo.* For each unit and associated origin-destination pair, the total tonnage of unit equipment carried by over-sized cargo capable aircraft plus the total tonnage not delivered must be greater than or equal to the movement requirement for over and out-sized cargo:

$$\sum_{a: ACCargo(a, "over") > 0} \sum_{e1} \sum_{e2} \sum_{e3} \sum_{t \in DSetX(u, a, r, t)} TonsUE(u, a, r, t) + UENoGo(u, i, k) \geq (CargoP(u, "over") + CargoP(u, "out")) * MoveUE(u, i, k) \quad \forall u, i, k : MoveUE(u, i, k) > 0.$$

The right-hand-side of the constraint is valid because out-sized cargo capable carriers are also over-sized cargo capable.

(4) *Demand Satisfaction Constraints for Troops.* For each unit and associated origin-destination pair, the total number of troops airlifted to the theater plus those not airlifted must be greater than or equal to the movement requirement for troops:

$$\sum_a \sum_{e1} \sum_{e2} \sum_{e3} \sum_{t \in DSetX(u, a, r, t)} TPAX(u, a, r, t) + PAXNoGo(u, i, k) \geq MovePAX(u, i, k) \quad \forall u, i, k : MovePAX(u, i, k) > 0.$$

b. Aircraft Balance Constraints

The number of aircraft *a* assigned for airlift missions (or to be recovered) must be no more than the number of aircraft *a* available for use. The three different kinds of aircraft balance constraints are:

(1) *Aircraft Balance Constraint at Origin Airfield.* For each aircraft *a*, origin *i* and time period *t* combination, the total number of aircraft assigned for airlift

missions, plus those inventoried must be equal to the total number of aircraft available from the previous period plus new supply of aircraft allocated to the origin and returns from previous missions:

$$\sum_u \sum_k \sum_{e1} \sum_{e2} \sum_{e3 \in DSatX(u,a,r,t)} X(u,a,r,t) + H(a,i,t) \\ = H(a,i,t-1) + Allot(a,i,t) + \sum_k \sum_{e1} \sum_{e2} \sum_{e3} \sum_{\substack{tp \in DSatY(a,r,tp) \\ tp + [RCTto(a,r)/24] = t}} Y(a,r,tp) \quad \forall a,i,t.$$

Note: $H(a,i,t-1)$ is only defined for t greater than 1.

(2) *Balance Constraint for Aircraft Allocation.* The total number of aircraft a allocated to the different origin airfields in each time period t must be no more than the new supply of aircraft a :

$$\sum_i Allot(a,i,t) \leq Supply(a,t) \quad \forall a,t : Supply(a,t) > 0.$$

(3) *Aircraft Balance Constraint at Destination Airfield.* For each aircraft a , destination k and time period t combination, the total number of aircraft a recovering from the destination airfield this period plus those inventoried must be equal to those waiting to return (inventory from last period) plus new arrivals at the destination:

$$\sum_i \sum_{e1} \sum_{e2} \sum_{e3 \in DSatY(a,r,t)} Y(a,r,t) + HP(a,k,t) \\ = HP(a,k,t-1) + \sum_u \sum_i \sum_{e1} \sum_{e2} \sum_{e3} \sum_{\substack{tp \in DSatX(u,a,r,tp) \\ tp + [CTtoK(a,r)/24] = t}} X(u,a,r,tp) \quad \forall a,k,t.$$

Note: $HP(a,k,t-1)$ is only defined for t greater than 1.

c. Aircraft Physical Limitation Constraints

The aircraft physical limitation constraints modelled are the troop carriage capacity, maximum payload and cargo floor space constraints.

(1) *Troop Carriage Capacity Constraints.* The total number of troops airlifted for each unit u , aircraft a , route r , and mission start time t combination must not be greater than the troop carriage capacity of aircraft a multiplied by the number of aircraft a assigned:

$$TPAX(u,a,r,t) \leq MaxPAX(a) * X(u,a,r,t) \quad \forall u,a,r,t \in DSetX(u,a,r,t).$$

(2) *Maximum Payload Constraints.* The total payload (equipment and men) airlifted for each unit u , aircraft a , route r , and mission start time t combination must not be greater than the maximum payload for aircraft a flying route r , multiplied by the number of aircraft a assigned:

$$TonsUE(u,a,r,t) + (PAXWt * TPAX(u,a,r,t)) \leq MaxLoad(a,r) * X(u,a,r,t) \\ \forall u,a,r,t \in DSetX(u,a,r,t).$$

(3) *Cargo Floor Space Constraints.* The total floor space taken up by troops and equipment for each unit u , aircraft a , route r , and mission start time t combination must not be greater than the aircraft cargo floor space multiplied by the loading efficiency factor and number of aircraft a assigned:

$$(PAXSqFt(a) * TPAX(u,a,r,t)) + (UESqFt(u) * TonsUE(u,a,r,t)) \\ \leq ACSqFt(a) * LoadEff(a) * X(u,a,r,t) \\ \forall u,a,r,t \in DSetX(u,a,r,t), ACSqFt(a) > 0.$$

d. Aircraft Utilization Rate Constraints

These constraints ensure that the average flying hours consumed per aircraft per day is less than AMC's established utilization rate for each aircraft type. Aircraft utilization rate constraints are modelled by comparing the actual flying hours consumed by an aircraft fleet in a deployment with the maximum achievable flying hours based on the utilization rate. The total flying hours consumed by an aircraft fleet in a deployment is equal to the total flying hours consumed on both delivery and recovery routes. The maximum achievable flying hours for each aircraft is given by the utilization rate multiplied by the number of productive time periods of that aircraft (CARD(t) represent the time horizon in the equation).

$$\sum_u \sum_r \sum_{t \in DSetX(u,a,r,t)} FltTime(a,r) * X(u,a,r,t) + \sum_r \sum_{t \in DSetY(a,r,t)} FltTime(a,r) * Y(a,r,t) \leq \sum_{t: Supply(a,t) > 0} URate(a) * (CARD(t) + 1 - t) * Supply(a,t) \quad \forall a.$$

e. Aircraft Handling Capacity of Airfield (MOG Constraint)

These constraints model the throughput or handling capacity of each airfield. They ensure that the LP does not route more aircraft through an airfield than it can handle each day.

The aircraft handling capacity constraints are modelled by computing the total MOG consumed (normalized to that of a narrow-body aircraft for comparison) in each period by each individual aircraft using the airfield. An airfield can serve as an origin, enroute, or a destination airfield; thus the total MOG consumed at a particular airfield on each day is the sum of the individual consumptions when serving in these

different capacities. The total MOG consumed must be less than the normalized MOG capacity of the airfield discounted by the MOG efficiency factor (it is impossible to fully utilize the MOG capacity due to deviations from scheduled ground times).

The airfield capacity that an aircraft consumes is equal to its MOG requirement multiplied by the ratio of time spent (in hours) under service to number of hours in a time period (in this case, 24 hours). MOG requirements are normalized to that of a narrow-body aircraft. The amount of time an aircraft spends at origin, enroute and destination airfields are the loading time (onload), enroute refuelling time (enr) and off-load time (offld) respectively. In the formulation of the constraints, MOG consumption at the origin and destination airfields are associated with the $X(u,a,r,t)$ variables only whereas, the MOG consumption at enroute airfields are associated with both the $X(u,a,r,t)$ and $Y(u,a,r,t)$ variables.

As the model supports air routes with zero to three enroute stops, it is also necessary to ensure that there is no double counting of MOG consumption (destination airfield names are used to replace non-existent enroute airfield names). Potential double counting of MOG consumption is prevented through conditional checks performed by the constraint equations. The constraint equation follows:

The conditional checks differ due to the multiple roles (origin, enroute and destination) that an airfield may serve. When the airfield is serving as an origin, the conditional check will ensure that only permissible airlift missions are allowed; i.e., valid combination of unit u , aircraft a , route r , and mission start time t .

When the airfield is serving as an enroute, four conditional checks are required. The first conditional check ensures a valid combination of indices; i.e., permissible unit u , aircraft a , mission start time t combination. The second conditional check ensures that the time of arrival at the airfield is the time period of concern. The third conditional check ensures that the aircraft come from a different airfield and serves the purpose of preventing double counting. The fourth conditional check ensures that the time taken to reach the airfield of concern is not equal to the time required to reach the destination (or origin) airfield. This last check also ensures that proper aircraft ground time is used in the MOG computation. For example, if the time taken to reach enroute $e3$ and destination k are the same, this implies that the aircraft has reached its destination and no enroute airfield capacity should be consumed. The corresponding aircraft off-load MOG consumption is computed when the airfield is considered as a destination node.

When serving as a destination airfield, two conditional checks are required. The first conditional check ensures a valid combination of indices. The second conditional check ensures that the time of arrival at the airfield is the time period of concern.

V. PERFORMANCE, ANALYTIC INSIGHTS AND LIMITATIONS

A. PERFORMANCE

The performance of the optimization model on the IBM RS6000 model 590 Unix workstation is relatively fast. For a sample problem with 20 units, 7 aircraft types, 17 airfields and 30 time periods, GAMS/XA and GAMS/OSL generated and solved the LP problem in about 90 seconds. There were 8273 permissible decision variables and 6349 constraint equations after all the problem reduction using dynamic sets were performed. The optimization model takes about 10 times longer when the same problem is solved on a personal computer (486/33 AT machine with 32MB of RAM). The total generation and solve times on the personal computer is about 15 minutes.

The manner in which the optimization model is implemented reduces the amount of external data processing and data entry time (as most data can be entered in the format in which they are made available). For example, with readily available airfields' geographical location and aircraft's cruise speed data, the model computes the cumulative time a particular aircraft takes to reach a designated airfield along a route. The data entry time for the above sample problem is about one and a half hours.

Thus, it can be seen that the overall response time of the model (under 2 hours) is relatively fast; this is a strength of the model.

B. ANALYTIC INSIGHTS

Broad insights into the strategic airlift system can be gained from the optimization model. For any particular set of input data, the insights gained include answers to the following mobility questions:

- **Adequacy of Assets:** Indicate whether aircraft and airfield assets are adequate for a deployment scenario.
- **Impact of Any Shortfall in Airlift Capability:** Allow the analyst to assess the impact by reporting the number of troops and tons of equipment of each unit that are airlifted late or could not be airlifted.
- **System "bottle-necks":** Indicate which part (aircraft or airfields) of the airlift system is restricting the flow of troops and equipment. These reports can also give ideas on how to improve the airlift system output. For example, increasing the material handling equipment in those airfields that support a large number of aircraft (high MOG consumption) can increase aircraft handling capacity. An analyst can also gauge the optimal number of CRAF aircraft to mobilize. For example, if the system is airfield constrained then mobilizing additional CRAF assets may not help the system; on the contrary, it may increase congestion and cost.
- **Balance aircraft and airfields assets:** This factor is important as there are limited military budgets and the USAF has to make a trade-off between buying aircraft and keeping airfields open. Ideally, the combination of assets should be such that aircraft utilization rates and airfields MOG consumption for most deployment scenarios are close to their published capacities. This is to ensure a good aircraft to airfield ratio.
- **Fleet Mix Studies:** By running different deployment scenarios, an analyst is able to assess which assets-mix option is the best overall option for supporting the different regional contingency plans.

C. MODEL LIMITATIONS

Two limitations of the optimization model are the inability to handle local traffic congestion and low fidelity. The true impact of these limitations are not quantifiable at the moment, and further validation and research are needed before it can be ascertained. These two limitations are caused by a mismatch between the time resolution (in days) and aircraft flying time and ground time (in hours). A more refined time resolution was not used in this research as initial investigation indicated that the problem size is large and requires data aggregation. A more refined time resolution though desired (more time periods for the same number of days) may increase the LP size beyond GAMS or the solvers' capability. This time resolution issue, however, warrants further investigation.

1. Local Traffic Congestion

Although the aircraft handling capacity of each airfield is observed by the model, airlift missions may still be routed in a manner that causes local congestion. For example, all aircraft routed through an airfield on a particular day could arrive within a small time window instead of being spread over the whole day. In reality, this would cause local congestion, even though the model's representation of aircraft handling capacity is observed.

2. Low Fidelity

The arrivals of aircraft at the origin and destination airfields are rounded-off to the nearest day (resolution of the time period). This round-off affects the fidelity and accuracy of the model. For example, rounding-off may increase the MOG consumption

of an airfield on one day and decrease the MOG consumption of the same airfield on the next day. Round-off results in lumpy flows through airfields, and hence, errs on the side of pessimism when MOG represents a binding constraint on the system flow. This is to be contrasted with the more optimistic smoothing fractional flow approach utilized by RAND in CONOP [Ref. 4].

VI. CONCLUSIONS AND RECOMMENDATIONS

A. CONCLUSIONS

The USAF strategic airlift system has been successfully modelled (although not in its entirety as use of tanker aircraft are not incorporated) as a multi-commodity, multi-period network flow model with a large number of side constraints.

Broad insights (some of which are currently not available from existing models such as Thruput or MOM) into the strategic airlift system can be gained by using the model. Some of the insights that can be gained include identification of system "bottle-necks" and the impact of any shortfall in airlift capability.

In addition to providing insights into the airlift system, the model also has relatively fast turnaround time. This virtue makes the model a useful tool in situations (e.g., initial planning phase of a major regional conflict development) where time is of the essence and where quick answers are desired. Its ability to furnish quick answers without tying down a massive amount of manpower or computer resources is important in such time critical circumstances.

B. RECOMMENDATIONS

The following are some recommendations for model enhancement.

1. Incorporate Use of Tanker Aircraft

One enhancement to the model is to incorporate the use of tanker aircraft in a deployment scenario. Such an enhancement would allow the airlift system to be examined from a much wider perspective. A possible way to incorporate the use of tanker aircraft is the "airbase in the sky" concept employed by RAND's CONOP optimization model. This concept basically treats the aerial refuelling areas as enroute airfields and can be implemented in the existing model without major changes to GAMS code. A more realistic representation of aerial refueling would also account for "diverts", i.e., planned aerial refueling which are not executed for unplanned reasons. Incorporating this enhancement would require major research and development.

2. Increase MOG Fidelity

For a more accurate modelling approach, it is essential that "ground services MOG" be distinguished from "parking space MOG". This distinction is necessary as aircraft inventoried at the origin and destination airfields require only "parking space MOG" and not "ground services MOG" once they have loaded or unloaded their cargo. This point has been covered in the Assumptions section in Chapter II. If data were available, it would be easy to formulate MOG constraints for each of several ground services.

3. Investigate the Feasibility of Improving Time Resolution

Another possible enhancement to the model is to improve the resolution of the time period (e.g., time could be discretized into 12 hour or smaller blocks instead of

days). Such an improvement if feasible would certainly improve the fidelity of the model and alleviate the two limitations of the models cited in Chapter V. However, improving the resolution of the time period does have a high price in terms of increasing the size of the LP. It is therefore prudent to assess the relative merits before embarking on such a move.

4. Validate MOG Efficiency Factor

The MOG efficiency factor is introduced as a discount factor to offset the effect of random aircraft ground times (which implies that an airfield cannot be planned to be fully utilized). The appropriate efficiency factor however, is presently unknown and needs to be investigated. One possible approach is to employ a simulation model to help obtain a realistic efficiency factor.

5. Stochastic Modelling

Aircraft reliability and ground times at on-load, off-load, and enroute airfields are inherently random aspects of a strategic airlift system. These stochastic factors can significantly affect the performance of an airlift system, particularly when infrastructure (e.g., airfield capacity) represents a binding constraint. One possible enhancement to the deterministic model is to apply stochastic optimization to develop a strategic airlift model in which aircraft reliability and ground times are modeled as random variables with known distribution.

APPENDIX A. LISTING OF DATA SOURCES

This appendix is a listing of the data sources. The layout is in the order of the entity name (as in the GAMS formulation) followed by a short description and the source from which the data originate

A. MOVEMENT REQUIREMENT DATA

Name	Description	Source
MoveUE(u,i,k)	Movement requirement for equipment	scenario
CargoP(u,cc)	Proportion of cargo classes (bulk, over, out)	scenario
MovePAX(u,i,k)	Movement requirement for troops	scenario
ALD(u)	Available load date	scenario
RDD(u)	Required delivery date	scenario

B. PENALTY DATA

Name	Description	Source
LatePen(u,c)	Lateness penalty	analyst's input
NoGoPen(u,c)	Non-delivery penalty	analyst's input
MaxLate	Maximum allowed lateness for delivery	analyst's input

C. CARGO DATA

Name	Description	Source
UESqFt(u)	Cargo space taken up by equipment	scenario
PAXWt	Average troop weight	AMC Load Planning Guide

D. AIRCRAFT DATA

Name	Description	Source
Supply(a,t)	New aircraft made available	scenario
ACSize(a,ab)	Aircraft body type	AMC
ACCargo(a,cc)	Aircraft-cargo compatibility	AMC
MaxFAX(a)	Aircraft troop carriage capacity	AFR 76-2, AMCP 55-41
PAXSqft(a)	Cargo space consumed by a soldier	aircraft-9, 55-41
ACSqFt(a)	Cargo space available	AMC Load Planning Guide

D. AIRCRAFT DATA (continued)

Name	Description	Source
LoadEff(a)	Cargo space loading efficiency	analyst's input
Spd(a)	Aircraft block speed	AMC
GTime(a,ga)	Aircraft ground time	AMC
URate(a)	Established utilization rate	AMC
ACRange(a,rangeband)	Aircraft range points	aircraft-9, 55-41
ACLload(a,rangeband)	Aircraft load at range point	aircraft-9, 55-41

E. AIRFIELD DATA

Name	Description	Source
Crd(af,coords)	Decimal airfield coordinates	JFAST GEOFILE database
MOGCap(af,ab)	MOG capacity by aircraft type	AMC
MOGEff	MOG efficiency factor	analyst's input

F. AIRCRAFT-ROUTE DATA (Dynamic Sets)

Name	Description	Source
VRouteX(a,i,k,e1,e2,e3)	Aircraft-delivery route compatibility dynamic set	analyst's input
VRouteY(a,i,k,e1,e2,e3)	Aircraft-recovery route compatibility dynamic set	analyst's input

The above are the original data that are required by the program. All other data are computed by the GAMS model itself.

APPENDIX B. GAMS FORMULATION LISTING

GAMS 2.25.064 AIX RS/6000P
09/07/94 09:58:22
Strategic Airlift Asset Optimization Model Spring 1994

```
2 * Thesis by: Cpt Lim, Teo-Weng
3 * Advisors: Professor Richard E. Rosenthal
4 *           Dr. David P. Morton
5 *           Professor Gerald G. Brown
6 * Naval Postgraduate School
7 *
8 *----- GAMS AND DOLLAR CONTROL OPTIONS -----
9
14 OPTIONS
15     LIMCOL = 0, LIMROW = 0 , SOLPRINT = OFF, DECIMALS = 2
16     RESLIM = 19000, ITERLIM = 400000, OPTCR = 0.1 , SEED = 3141;
17
18 ***** INDICES DECLARATION *****
19
20 SETS
21
22
23     U      units
INCLUDE /home/limt/unitname.dat
25 /
26 UnitA    USMC 3 MAB
27 UnitB    USMC 1 MAF
28 UnitC    USMC 2 MAB
29 UnitD    USA 4 Light Inf
30 UnitE    USA 2 Mech
31 UnitF    USA 25 AAD
32 UnitG    24 A10s
33 UnitH    24 F16s and 24 F15s
34 UnitI    24 A10s
35 UnitJ    24 F16s and 24 F15s
36 UnitK    24 A10s
37 UnitL    24 F16s
38 UnitM    24 F15s
39 UnitN    24 A10s
40 UnitO    24 F16s
41 UnitP    24 F15s
42 UnitQ    24 F16s and 24 F15s
43 UnitR    24 F16s and 24 F15s
44 UnitS    24 F16s and 24 F15s
45 UnitT    24 F16s and 24 F15s
46 /
47
48     A      aircraft
INCLUDE /home/limt/acname.dat
50 /
51 C5
52 C17
53 C141
54 C130
55 747P
```

```

56 747C
57 DC10
58 /
59
60 CRAF(A) civilian aircraft
INCLUDE /home/limt/craf.dat
62 /
63 747D
64 747C
65 DC10
66 /
67
68 MILAC(A) military aircraft
INCLUDE /home/limt/milac.dat
70 /
71 C5
72 C17
73 C141
74 C130
75 /
76
77 AB aircraft body type
78 * Aircraft are classified as WB (widebody), NB (narrow body),
79 * GM (ground maneuverable), or TT (tactical).
80 / WB, NB, GM, TT /
81
82 GA ground activities
83 * The different types of ground activities an aircraft goes
84 * through are on-load (ONLD), enroute turnaround (ENR) and
85 * off-load (OFFLD).
86 / ONLD, ENR, OFFLD /
87
88 T time periods in days
INCLUDE /home/limt/periods.dat
90 * Time period should cover up till the last RDD plus
91 * the maximum allowed lateness
92 /
93 DAY1 * DAY30
94 /
95
97 ALIAS(T,TP);
98
99 SETS
100
101 C cargo type / UE, PAX /
102 * UE stands for unit equipment and PAX for troops
103
104 CC cargo class / BULK, OVER, OUT /
105
106 AF airfields in general
INCLUDE /home/limt/afname.dat
108 /
109 QFOE Mildenhall
110 TMKH Pope AFB
111 TYFR Ramstein AB
112 XDAT Travis AFB
113 FFTJ Dhahran
114 UGZX Riyadh
115 PKVV Masirah
116 KNVD Hickam

```

```

117 FXSB Elmendorf AFB
118 WWYK Tinker AFB
119 NNGX Boston Logan
120 UTKY San Francisco Int
121 FJXT Dover AFB
122 ZNRE Yokota
123 HTDS London Gatwick
124 FGDC Diego Garcia NAF
125 XBGX Torrejon
126 /
127
129 I(AF) origin airfields
INCLUDE /home/limt/orgname.dat
131 /
132 QFQE Mildenhall
133 TMKH Pope AFB
134 TYFR Ramstein AB
135 XDAT Travis AFB
136 /
137
138 K(AF) destination airfields in theater
INCLUDE /home/limt/destname.dat
140 /
141 FFTJ Dhahran
142 UGZX Riyadh
143 PKVV Masirah
144 /
145
146 E1(AF) first set of enroute airfields
INCLUDE /home/limt/elname.dat
148 /
149 QFQE Mildenhall
150 TMKH Pope AFB
151 TYFR Ramstein AB
152 XDAT Travis AFB
153 KNMD Hickam
154 FXSB Elmendorf AFB
155 WWYK Tinker AFB
156 NNGX Boston Logan
157 UTKY San Francisco Int
158 FJXT Dover AFB
159 /
160
161 E2(AF) second set of enroute airfields
INCLUDE /home/limt/e2name.dat
163 /
164 QFQE Mildenhall
165 TYFR Ramstein AB
166 FFTJ Dhahran
167 UGZX Riyadh
168 PKVV Masirah
169 KNMD Hickam
170 ZNRE Yokota
171 HTDS London Gatwick
172 /
173
174 E3(AF) third set of enroute airfields
INCLUDE /home/limt/e3name.dat
176 /
177 TYFR Ramstein AB

```

```

178 FFTJ Dhahran
179 UGZX Riyadh
180 PKVV Misarah
181 FGDC Diego Garcia NAF
182 XBGX Terrejon
183 /
184 ;
185
186 SET VROUTEX(A, I, K, E1, E2, E3) indicate aircraft-delivery route
* compatibility ;
187 * Used to control aircraft-route matching; i.e., allow military
188 * aircraft to fly on military routes and civilian aircraft to fly
189 * on civilian routes. Members of SET indicate compatibility.
INCLUDE /home/lim/vroutex.set
191 * Member indicates aircraft-route compatibility
192 * Substitute destination name for E1, E2, E3 when such enroute
193 * airfields are not needed.
194 VRouteX(MILAC, "TMKH", "FFTJ", "WWYK", "FFTJ", "FFTJ") = yes;
195 VRouteX(MILAC, "TMKH", "UGZX", "WWYK", "UGZX", "UGZX") = yes;
196 VRouteX(MILAC, "TMKH", "FFTJ", "TYFR", "FFTJ", "FFTJ") = yes;
197 VRouteX(MILAC, "TMKH", "UGZX", "TYFR", "UGZX", "UGZX") = yes;
198 VRouteX(MILAC, "TMKH", "FFTJ", "QFQE", "FFTJ", "FFTJ") = yes;
199 VRouteX(MILAC, "TMKH", "UGZX", "QFQE", "UGZX", "UGZX") = yes;
200 VRouteX(CRAF, "TMKH", "FFTJ", "TMKH", "TYFR", "FFTJ") = yes;
201 VRouteX(CRAF, "TMKH", "UGZX", "TMKH", "TYFR", "UGZX") = yes;
202 VRouteX(CRAF, "TMKH", "PKVV", "TMKH", "TYFR", "PKVV") = yes;
203 VRouteX(CRAF, "TMKH", "FFTJ", "TMKH", "HTDS", "FFTJ") = yes;
204 VRouteX(CRAF, "TMKH", "UGZX", "TMKH", "HTDS", "UGZX") = yes;
205 VRouteX(CRAF, "TMKH", "PKVV", "TMKH", "HTDS", "PKVV") = yes;
206 VRouteX(MILAC, "XDAT", "FFTJ", "WWYK", "FFTJ", "FFTJ") = yes;
207 VRouteX(MILAC, "TMKH", "FFTJ", "WWYK", "FFTJ", "FFTJ") = yes;
208 VRouteX(MILAC, "XDAT", "UGZX", "WWYK", "UGZX", "UGZX") = yes;
209 VRouteX(MILAC, "TMKH", "UGZX", "WWYK", "UGZX", "UGZX") = yes;
210 VRouteX(MILAC, "XDAT", "FFTJ", "TYFR", "FFTJ", "FFTJ") = yes;
211 VRouteX(MILAC, "TMKH", "FFTJ", "TYFR", "FFTJ", "FFTJ") = yes;
212 VRouteX(MILAC, "XDAT", "UGZX", "TYFR", "UGZX", "UGZX") = yes;
213 VRouteX(MILAC, "TMKH", "UGZX", "TYFR", "UGZX", "UGZX") = yes;
214 VRouteX(MILAC, "XDAT", "FFTJ", "QFQE", "FFTJ", "FFTJ") = yes;
215 VRouteX(MILAC, "TMKH", "FFTJ", "QFQE", "FFTJ", "FFTJ") = yes;
216 VRouteX(MILAC, "XDAT", "UGZX", "QFQE", "UGZX", "UGZX") = yes;
217 VRouteX(MILAC, "TMKH", "UGZX", "QFQE", "UGZX", "UGZX") = yes;
218 VRouteX(CRAF, "XDAT", "FFTJ", "NNGX", "TYFR", "FFTJ") = yes;
219 VRouteX(CRAF, "XDAT", "UGZX", "NNGX", "TYFR", "UGZX") = yes;
220 VRouteX(CRAF, "XDAT", "PKVV", "NNGX", "TYFR", "PKVV") = yes;
221 VRouteX(CRAF, "XDAT", "FFTJ", "NNGX", "HTDS", "FFTJ") = yes;
222 VRouteX(CRAF, "XDAT", "UGZX", "NNGX", "HTDS", "UGZX") = yes;
223 VRouteX(CRAF, "XDAT", "PKVV", "NNGX", "HTDS", "PKVV") = yes;
224 VRouteX(A, "TYFR", "FFTJ", "TYFR", "TYFR", "FFTJ") = yes;
225 VRouteX(A, "TYFR", "UGZX", "TYFR", "TYFR", "UGZX") = yes;
226 VRouteX(A, "TYFR", "PKVV", "TYFR", "TYFR", "PKVV") = yes;
227 VRouteX(A, "QFQE", "FFTJ", "TYFR", "FFTJ", "FFTJ") = yes;
228 VRouteX(A, "QFQE", "UGZX", "TYFR", "UGZX", "UGZX") = yes;
229 VRouteX(A, "QFQE", "PKVV", "TYFR", "PKVV", "PKVV") = yes;
230 VRouteX(CRAF, "XDAT", K, "FXSB", "ZNRE", "FGDC") = yes;
231 VRouteX(CRAF, "XDAT", K, "XDAT", "ZNRE", "FGDC") = yes;
232 VRouteX(MILAC, "TMKH", "PKVV", "WWYK", "UGZX", "UGZX") = yes;
233 VRouteX(MILAC, "TMKH", "PKVV", "QFQE", "UGZX", "UGZX") = yes;
234 VRouteX(MILAC, "TMKH", "PKVV", "TYFR", "UGZX", "UGZX") = yes;
235
236 SET VROUTEY(A, I, K, E1, E2, E3) indicate aircraft-recovery route

```

```

* compatibility ;
INCLUDE /home/limt/vroutey.set
238 * Member indicates aircraft-route compatibility
239 * Substitute destination name for E1, E2, E3 when such enroute
240 * airfields are not needed
241 VRouteY(MILAC,"TMKH","FFTJ","WWYK","FFTJ","FFTJ") = yes;
242 VRouteY(MILAC,"TMKH","UGZX","WWYK","UGZX","UGZX") = yes;
243 VRouteY(MILAC,"TMKH","FFTJ","TYFR","FFTJ","FFTJ") = yes;
244 VRouteY(MILAC,"TMKH","UGZX","TYFR","UGZX","UGZX") = yes;
245 VRouteY(MILAC,"TMKH","FFTJ","QFQE","FFTJ","FFTJ") = yes;
246 VRouteY(MILAC,"TMKH","UGZX","QFQE","UGZX","UGZX") = yes;
247 VRouteY(CRAF,"TMKH","FFTJ","NNGX","FFTJ","FFTJ") = yes;
248 VRouteY(CRAF,"TMKH","UGZX","NNGX","UGZX","UGZX") = yes;
249 VRouteY(CRAF,"TMKH","FFTJ","WWYK","FFTJ","FFTJ") = yes;
250 VRouteY(CRAF,"TMKH","UGZX","WWYK","UGZX","UGZX") = yes;
251 VRouteY(CRAF,"TMKH","FFTJ","TYFR","FFTJ","FFTJ") = yes;
252 VRouteY(CRAF,"TMKH","UGZX","TYFR","UGZX","UGZX") = yes;
253 VRouteY(CRAF,"TMKH","FFTJ","QFQE","FFTJ","FFTJ") = yes;
254 VRouteY(CRAF,"TMKH","UGZX","QFQE","UGZX","UGZX") = yes;
255 VRouteY(CRAF,"XDAT",K,"FXSR","ZNRE","FGDC") = yes;
256 VRouteY(CRAF,"XDAT",K,"KNMD","ZNRE","FGDC") = yes;
257 VRouteY(CRAF,"XDAT",K,"UTKY","ZNRE","FGDC") = yes;
258 VRouteY(MILAC,"TMKH","PKVV","WWYK","UGZX","PKVV") = yes;
259 VRouteY(MILAC,"TMKH","PKVV","QFQE","UGZX","PKVV") = yes;
260 VRouteY(MILAC,"TMKH","PKVV","TYFR","UGZX","PKVV") = yes
261
262 SET COORDS coordinates / LAT, LON /;
263
264 *+++++ MOVEMENT REQUIREMENT DATA ++++++
265
266 PARAMETER MOVEUE(U,I,K) units' equipment movement requirements
INCLUDE /home/limt/moveue.dat
268 * Entries are in terms of 100 tons and in the order of
269 * unit name, origin airfield and destination airfield
270 /
271 UnitA.XDAT.FFTJ = 185.77
272 UnitB.TYFR.FFTJ = 6.92
273 UnitC.XDAT.FFTJ = 63.23
274 UnitD.TMKH.FFTJ = 114.94
275 UnitE.TYFR.UGZX = 663.69
276 UnitF.TMKH.UGZX = 238.27
277 UnitG.TYFR.UGZX = 5.03
278 UnitH.XDAT.UGZX = 10.13
279 UnitI.QFQE.UGZX = 5.03
280 UnitJ.XDAT.UGZX = 10.13
281 UnitK.TYFR.UGZX = 5.03
282 UnitL.TYFR.UGZX = 4.91
283 UnitM.TYFR.UGZX = 5.22
284 UnitN.TYFR.UGZX = 5.03
285 UnitO.TYFR.PKVV = 4.91
286 UnitP.TYFR.PKVV = 5.22
287 UnitQ.TMKH.PKVV = 10.13
288 UnitR.TMKH.UGZX = 10.13
289 UnitS.TMKH.UGZX = 10.13
290 UnitT.XDAT.UGZX = 10.13
291 /
292 ;
293
294 TABLE CARGOP(U,CC)
295 * Proportion of cargo types (bulk, over, out) belonging to

```

```

296 * unit u moving from i to k. Proportions for the different
297 * types of cargo must add to 1.
INCLUDE /home/limt/cargcp.dat
299      BULK  OVER  OUT
300 UnitA  0.383  0.520  0.097
301 UnitB  0.470  0.530  0.0
302 UnitC  0.331  0.651  0.018
303 UnitD  0.190  0.797  0.013
304 UnitE  0.023  0.575  0.402
305 UnitF  0.064  0.838  0.098
306 UnitG  0.616  0.384  0.0
307 UnitH  0.661  0.339  0.0
308 UnitI  0.616  0.384  0.0
309 UnitJ  0.661  0.339  0.0
310 UnitK  0.616  0.384  0.0
311 UnitL  0.658  0.342  0.0
312 UnitM  0.665  0.335  0.0
313 UnitN  0.616  0.384  0.0
314 UnitO  0.616  0.384  0.0
315 UnitP  0.658  0.342  0.0
316 UnitQ  0.661  0.339  0.0
317 UnitR  0.661  0.339  0.0
318 UnitS  0.661  0.339  0.0
319 UnitT  0.661  0.339  0.0
320 ;
321
322 PARAMETER MOVEPAX(U,I,K)  units' troop movement requirements
INCLUDE /home/limt/movepax.dat
324 * Entries are in terms of 100 men and in the order of
325 * unit name, origin airfield and destination airfield
326 /
327 UnitA.XDAT.FFTJ = 126.98
328 UnitB.TYFR.FFTJ = 13.84
329 UnitC.XDAT.FFTJ = 52.59
330 UnitD.TMKH.FFTJ = 97.76
331 UnitE.TYFR.UGZX = 199.37
332 UnitF.TMKH.UGZX = 190.82
333 UnitG.TYFR.UGZX = 3.92
334 UnitH.XDAT.UGZX = 8.46
335 UnitI.QFQE.UGZX = 2.92
336 UnitJ.XDAT.UGZX = 8.46
337 UnitK.TYFR.UGZX = 3.92
338 UnitL.TYFR.UGZX = 4.74
339 UnitM.TYFR.UGZX = 3.72
340 UnitN.TYFR.UGZX = 3.92
341 UnitO.TYFR.PKVV = 4.74
342 UnitP.TYFR.PKVV = 3.72
343 UnitQ.TMKH.PKVV = 8.46
344 UnitR.TMKH.UGZX = 8.46
345 UnitS.TMKH.UGZX = 8.46
346 UnitT.XDAT.UGZX = 8.46
347 /
348
349 PARAMETER ALD(U)  available load date for unit u
INCLUDE /home/limt/ald.dat
351 /
352 UnitA  8
353 UnitE  16
354 UnitC  3
355 UnitD  21

```

```

356 UnitE 3
357 UnitF 11
358 UnitG 1
359 UnitH 1
360 UnitI 2
361 UnitJ 2
362 UnitK 2
363 UnitL 2
364 UnitM 3
365 UnitN 3
366 UnitO 3
367 UnitP 3
368 UnitQ 4
369 UnitR 4
370 UnitS 4
371 UnitT 4
372 /
373
374 PARAMETER RDD(U) required delivery date for unit u
INCLUDE /home/limt/rdd.dat
376 /
377 UnitA 17
378 UnitB 20
379 UnitC 8
380 UnitD 26
381 UnitE 16
382 UnitF 19
383 UnitG 4
384 UnitH 4
385 UnitI 5
386 UnitJ 5
387 UnitK 5
388 UnitL 6
389 UnitM 6
390 UnitN 6
391 UnitO 6
392 UnitP 7
393 UnitQ 7
394 UnitR 7
395 UnitS 8
396 UnitT 8
397 /
398
399 SCALAR MAXLATE maximum allowed lateness in days
INCLUDE /home/limt/maxlate.dat
401 * Maximum allowed lateness for delivery in days
402 / 4 /
404 ;
405
406 TABLE LATEPEN(U,C) lateness penalty per day by unit and cargo
INCLUDE /home/limt/latepen.dat
408 * Late penalty for unit equipment should be measured in terms
409 * of per 100 ton per day. Late penalty for PAX should be
410 * measured in terms of per 100 PAX per day.
411 UE PAX
412 UnitA 0.005 0.008
413 UnitB 0.14 0.072
414 UnitC 0.016 0.019
415 UnitD 0.009 0.010
416 UnitE 0.002 0.005

```

```

417 UnitF 0.004 0.005
418 UnitG 0.20 0.255
419 UnitH 0.197 0.236
420 UnitI 0.199 0.255
421 UnitJ 0.197 0.236
422 UnitK 0.199 0.255
423 UnitL 0.204 0.211
424 UnitM 0.192 0.269
425 UnitN 0.199 0.255
426 UnitO 0.204 0.211
427 UnitP 0.192 0.269
428 UnitQ 0.197 0.236
429 UnitR 0.197 0.236
430 UnitS 0.197 0.236
431 UnitT 0.197 0.236
432 ;
433
434 PARAMETER NOGOPEN(U,C) penalty for not fulfilling requirement ;
435 * NOGOPEN should be larger than (MAXLATE x LATEPEN) for the
436 * respective unit and cargo type. This is for consistency or
437 * else the LP may choose not to send instead of sending the
438 * cargo late.
INCLUDE /home/limt/nogopen.dat
439 NOGOPEN(U,C) = 2 * MAXLATE * LATEPEN(U,C)
440 ;
441 ***** CARGO DATA *****
442 *
443 PARAMETER UESQFT(U) ave. cargo space (in 1000 sq. ft.) per 100
444 * tons of unit u's cargo
INCLUDE /home/limt/uesqft.dat
446 * Entries are in terms of 1000 sq. ft. per 100 ton
447 /
448 UnitA 2.7
449 UnitB 2.6
450 UnitC 2.9
451 UnitD 3.0
452 UnitE 2.3
453 UnitF 3.1
454 UnitG 2.4
455 UnitH 2.4
456 UnitI 2.4
457 UnitJ 2.4
458 UnitK 2.4
459 UnitL 2.4
460 UnitM 2.4
461 UnitN 2.4
462 UnitO 2.4
463 UnitP 2.4
464 UnitQ 2.4
465 UnitR 2.4
466 UnitS 2.4
467 UnitT 2.4
468 /
469
470 SCALAR PAXWT ave. wt (in 100 tons) of 100 troops / 0.2 /;
471 * Average PAX weight is set at 400 lbs or 0.2 stons inclusive of
472 * personal equipment. Therefore, average weight of 100 PAX is
473 * 0.2 hundred stons.
474
475 ***** AIRCRAFT DATA *****

```

```

476
477 PARAMETER SUPPLY(A,T) no. of new aircraft made available on day T
INCLUDE /home/limt/acsupply.dat
479 * SUPPLY(A,T) represents additional number of aircraft (A) that
480 * are first made available for use at time period (T).
481 /
482 C5.DAY1 = 10
483 C5.DAY6 = 30
484 C5.DAY11 = 40
485 C17.DAY1 = 2
486 C17.DAY6 = 6
487 C17.DAY11 = 8
488 C141.DAY1 = 20
489 C141.DAY6 = 60
490 C141.DAY11 = 80
491 C130.DAY1 = 20
492 C130.DAY6 = 60
493 C130.DAY11 = 80
494 747P.DAY6 = 10
495 747P.DAY11 = 30
496 747P.DAY16 = 20
497 747C.DAY6 = 5
498 747C.DAY11 = 25
499 747C.DAY16 = 50
500 DC10.DAY6 = 5
501 DC10.DAY11 = 25
502 DC10.DAY16 = 50
503 /
504 ;
505
506 SET ACSIZE(A,AB) aircraft body type
INCLUDE /home/limt/acsize.dat
508 /
509 C5.WB
510 C17.GM
511 C141.NB
512 C130.TT
513 747P.WB
514 747C.WB
515 DC10.WB
516 /
517 ;
518
519 TABLE ACCARGO(A,CC) aircraft and cargo class matching
INCLUDE /home/limt/accargo.dat
521 * An entry of 1.0 represents compatibility
522      BULK   OVER   OUT
523 C5      1.0   1.0   1.0
524 C17     1.0   1.0   1.0
525 C141    1.0   1.0   0.0
526 C130    1.0   1.0   0.0
527 747P    0.0   0.0   0.0
528 747C    1.0   0.0   0.0
529 DC10    0.0   0.0   0.0
530 ;
531
532 PARAMETER MAXPAX(A) troop carriage capacity (in 100s) of aircraft
INCLUDE /home/limt/acmaxpax.dat
534 * Entries are in terms of 100s of men
535 /

```

```

536 C5      0.73
537 C17     0.54
538 C141    1.43
539 C130    0.44
540 747P    4.02
541 747C    0.0
542 DC10    2.79
543 /
544 ;
545
546 PARAMETER PAXSQFT(A)  cargo space (in 1000 sq. ft.) occupied by
*                          100 PAX
INCLUDE /home/limt/paxsqft.dat
548 * Entries are in terms of 1000 sq. ft. per 100 PAX
549 * C5 PAX passenger seats upstairs and does not consume cargo space
550 * CRAF PAX haulers have 0 sq. ft. per PAX and have 0 sq. ft. of
551 * cargo space.
552 /
553 C5      0.0
554 C17     0.7
555 C141    0.7
556 C130    0.7
557 747P    0.0
558 747C    0.0
559 DC10    0.0
560 /
561 ;
562
563 PARAMETER ACSQFT(A)  aircraft cargo space (in 1000 sq. ft.)
INCLUDE /home/limt/acsqft.dat
565 * Entries are in terms of 1000 sq. ft.
566 * CRAF PAX haulers have 0 sq. ft. of cargo space.
567 /
568 C5      2.562
569 C17     1.533
570 C141    1.043
571 C130    0.452
572 747P    0.0
573 747C    2.772
574 DC10    0.0
575 /
576 ;
577
578 PARAMETER LOADEFF(A)  loading efficiency for aircraft type
INCLUDE /home/limt/loadeff.dat
580 * Loading Efficiency gives the proportion of cargo space that
581 * could be actually filled. Loading Efficiency does not apply
582 * to CRAF PAX haulers which have 0 sq. ft of cargo space.
583 /
584 C5      0.8
585 C17     0.8
586 C141    0.8
587 C130    0.8
588 747P    0.0
589 747C    1.0
590 DC10    0.0
591 /
592 ;
593
594 PARAMETER SPD(A)      aircraft block speed in knots

```

```

INCLUDE      /home/limt/acspeed.dat
596 /
597 C5      419
598 C17     440
599 C141    397
600 C130    215
601 747P    450
602 747C    450
603 DC10    450
604 /
605 ;
606
607 TABLE GTIME(A,GA) aircraft ground activity duration in hrs
INCLUDE      /home/limt/gtime.dat
609          ONLD   ENR   OFFLD
610 C5        3.25  2.25  3.25
611 C17       2.25  2.25  2.25
612 C141      2.25  2.25  2.25
613 C130      1.5   1.5   1.5
614 747P      3.0   2.0   3.0
615 747C      4.0   2.0   3.0
616 DC10      3.0   2.0   3.0
617 ;
618
619 PARAMETER URATE(A) aircraft planned utilization rate
620 * Gives the planning norm for aircraft utilization.
INCLUDE      /home/limt/urate.dat
622 * Entries are in 100 hrs per aircraft per day
623 /
624 C5        0.109
625 C17       0.152
626 C141      0.102
627 C130      0.054
628 747P      0.10
629 747C      0.10
630 DC10      0.10
631 /
632 ;
633
634 ***** AIRCRAFT RANGE-PAYLOAD DATA *****
635 * The following tables allow for the computation of critical
636 * payload for a particular route. The entries in ACRANGE and
637 * ACLOAD (for a rangeband and aircraft pair) give the range and
638 * respective critical payload data for the aircraft. These data
639 * are used to interpolate the critical payload for a given range.
640
641 SET RANGE BAND / 1*7 /;
642
643 TABLE ACRANGE(A,RANGEBAND) aircraft range points
INCLUDE      /home/limt/acrange.dat
645          1      2      3      4      5      6      7
646 C5        2000  2500  3000  3500  4000  4500  10000
647 C17       2400  3400  4200  10000  0      0      0
648 C141      2000  2500  3000  3500  4000  4500  10000
649 C130      2000  4200  4800  10000  0      0      0
650 747P      4450  6200  10000  0      0      0      0
651 747C      2425  3000  3500  6000  0      0      0
652 DC10      3000  3500  6000  10000  0      0      0
653 ;
654

```

```

655 TABLE ACLOAD(A,RANGEBAND) aircraft payloads (in 100 tons) at range
INCLUDE /home/limt/acload.dat
657 * Entries are in terms of 100 tons
658      1      2      3      4      5      6      7
659 C5      1.127 0.999 0.873 0.757 0.630 0.506 0
660 C17     0.800 0.650 0      0      0      0      0
661 C141    0.344 0.299 0.259 0.203 0.161 0.114 0
662 C130    0.215 0.085 0      0      0      0      0
663 747P    0.64  0      0      0      0      0      0
664 747C    1.286 1.216 1.116 0      0      0      0
665 DC10    0.44  0      0      0      0      0      0
666 ;
667
668 PARAMETER SLOPE(A,RANGEBAND) slopes for interpolation;
669 * Slopes give the change in payload from rangeband i-1 to
670 * rangeband i.
671
672 SLOPE(A,RANGEBAND) =
673      0$(ORD(RANGEBAND) EQ 1) +
674      ( (ACLOAD(A,RANGEBAND-1)-ACLOAD(A,RANGEBAND))/
675        (1$(ACRANGE(A,RANGEBAND) EQ 0)+
676         (ACRANGE(A,RANGEBAND)-ACRANGE(A,RANGEBAND-1))
677         $(ACRANGE(A,RANGEBAND) GT 0)) )$(ORD(RANGEBAND) GT 1);
678
679 ***** AIRFIELD DATA *****
680
681 TABLE CRD(AF,COORDS) airfield coordinates in decimals
INCLUDE /home/limt/afcoord.dat
683      LAT      LON
684 QFQE      52.4      0.5
685 TMKH      35.2     -79.0
686 TYFR      49.4      7.6
687 XDAT      38.3     -121.9
688 FFTJ      26.3      50.2
689 UGZX      24.7      46.7
690 PKVV      20.7      58.9
691 KNMD      21.3     -157.9
692 FXSB      61.25    -149.8
693 WWYK      35.4     -97.4
694 NNGX      42.36    -71.01
695 UTKY      37.62    -122.4
696 FJXT      39.1     -75.5
697 ZNRE      35.8     139.4
698 HTDS      51.5      0.7
699 FGDC      -7.3      72.4
700 XBGX      40.49    -3.46
701 ;
702
703 TABLE MOGCAP(AF,AB) MOG capacity at airfield
704 * MOG in essence represents the airfield's aircraft handling
705 * capacity. MOG capacity depends on the aircraft body
706 * type. MOG figures are based on a host of factors such as
707 * ramp space, fuel availability, MHE, servicing, reception
708 * capability and contention with collocated combat units.
INCLUDE /home/limt/mogcap.dat
710      WB      NB      GM      TT
711 QFQE      5      9      9
712 TMKH      17     32     32
713 TYFR      8      22     22
714 XDAT      23     41     41

```

```

715 FFTJ 10 14 15
716 UGZY 5 10 13
717 PKVV 1 3 3
718 KNMD 30 41 41
719 FXSB 8 16 16
720 WWYK 9 16 16
721 NNGX 7 7 7
722 UTKY 7 7 7
723 FJXT 9 14 14
724 ZNRE 10 20 20
725 HTDS 3 12 12
726 FGDC 2 5 5
727 XBGX 10 12 12
728 ;
729
730 * set all tactical MOG availabilities to NB MOG/.75
731
732 MOGCAP(AF,'TT') = MOGCAP(AF,'NB')/.75;
733
734 SCALAR MOGEFF efficiency factor for MOG usage
INCLUDE /home/limt/mogeff.dat
736 * MOG efficiency factor is to cater for the fact that MOG capacity
737 * cannot be achieved due to the stochastic nature of ground time.
738 / 0.9 /
740 ;
741
742 ***** ROUTE PARAMETERS *****
743
744 * The following equations are used to compute the distance between
745 * any two airfields.
746
747 ALIAS (AF,AFP);
748
749 PARAMETERS FX(AF,AFP) result of sin cos argument of acos fcn
750 DIST(AF,AFP) distance between airfields;
751
752 SCALAR DTOR conversion factor from degrees to radians ;
753 DTOR = 0.017453293;
754
755 FX(AF,AFP) =
756 COS(DTOR*CRD(AF,'LAT'))*COS(DTOR*CRD(AFP,'LAT'))*
757 COS(DTOR*(CRD(AF,'LON')-CRD(AFP,'LON')))+
758 SIN(DTOR*CRD(AF,'LAT'))*SIN(DTOR*CRD(AFP,'LAT'));
759
760 DIST(AF,AFP)$(ORD(AF) NE ORD(AFP))
761 = 3437*((ARCTAN(SQRT(1-SQR(FX(AF,AFP))))/
762 FX(AF,AFP))$(FX(AF,AFP) GT 0) +
763 (3.141592653+ARCTAN(SQRT(1-SQR(FX(AF,AFP))))
764 /FX(AF,AFP))$(FX(AF,AFP) LT 0));
765
766 PARAMETER MAXLEG(I,K,E1,E2,E3) longest leg of each route ;
767 MAXLEG(I,K,E1,E2,E3) =
768 MAX(DIST(I,E1),DIST(E1,E2),DIST(E2,E3),DIST(E3,K));
769
770 PARAMETER MAXLOAD(A,I,K,E1,E2,E3) maximum payload on longest leg ;
771 * Gives maximum payload of an aircraft type on a particular route
772 MAXLOAD(A,I,K,E1,E2,E3) $ VROUTEX(A,I,K,E1,E2,E3) =
773 ACLOAD(A,'1')$(MAXLEG(I,K,E1,E2,E3) LE ACRANGE(A,'1')) +
774 (ACLOAD(A,'1')+SLOPE(A,'2')*(ACRANGE(A,'1')-MAXLEG(I,K,E1,E2,E3)))
775 $(MAXLEG(I,K,E1,E2,E3) GE ACRANGE(A,'1') AND

```

```

776             MAXLEG(I,K,E1,E2,E3) LE ACRANGE(A,'2'))      +
777 (ACLOAD(A,'2')+SLOPE(A,'3')*(ACRANGE(A,'2')-MAXLEG(I,K,E1,E2,E3)))
778             $(MAXLEG(I,K,E1,E2,E3) GE ACRANGE(A,'2') AND
779             MAXLEG(I,K,E1,E2,E3) LE ACRANGE(A,'3'))      +
780 (ACLOAD(A,'3')+SLOPE(A,'4')*(ACRANGE(A,'3')-MAXLEG(I,K,E1,E2,E3)))
781             $(MAXLEG(I,K,E1,E2,E3) GE ACRANGE(A,'3') AND
782             MAXLEG(I,K,E1,E2,E3) LE ACRANGE(A,'4'))      +
783 (ACLOAD(A,'4')+SLOPE(A,'5')*(ACRANGE(A,'4')-MAXLEG(I,K,E1,E2,E3)))
784             $(MAXLEG(I,K,E1,E2,E3) GE ACRANGE(A,'4') AND
785             MAXLEG(I,K,E1,E2,E3) LE ACRANGE(A,'5'))      +
786 (ACLOAD(A,'5')+SLOPE(A,'6')*(ACRANGE(A,'5')-MAXLEG(I,K,E1,E2,E3)))
787             $(MAXLEG(I,K,E1,E2,E3) GE ACRANGE(A,'5') AND
788             MAXLEG(I,K,E1,E2,E3) LE ACRANGE(A,'6'))      +
789 (ACLOAD(A,'6')+SLOPE(A,'7')*(ACRANGE(A,'6')-MAXLEG(I,K,E1,E2,E3)))
790             $(MAXLEG(I,K,E1,E2,E3) GE ACRANGE(A,'6') AND
791             MAXLEG(I,K,E1,E2,E3) LE ACRANGE(A,'7'))      ;
792
793 PARAMETER CTTOE1(A,AF,AF,AF,AF,AF) ;
794 * Cumulative time (in hours) taken to travel from origin airfield
795 * (I) to enroute airfield (E1) along the route specified inclusive
796 * of ground time.
797 CTTOE1(A,I,K,E1,E2,E3) $VROUTEX(A,I,K,E1,E2,E3) =
798 GTIME(A,'ONLD') + (DIST(I,E1)/SPD(A));
799
800 PARAMETER CTTOE2(A,AF,AF,AF,AF,AF) ;
801 * Cumulative time (in hours) taken to travel from origin airfield
802 * to enroute airfield (E2) along the route specified inclusive of
803 * ground time.
804 CTTOE2(A,I,K,E1,E2,E3) $VROUTEX(A,I,K,E1,E2,E3) =
805 CTTOE1(A,I,K,E1,E2,E3) +
806 (GTIME(A,'ENR') + (DIST(E1,E2)/SPD(A)))$DIST(E1,E2);
807
808 PARAMETER CTTOE3(A,AF,AF,AF,AF,AF) ;
809 * Cumulative time (in hours) taken to travel from origin airfield
810 * to enroute airfield (E3) along the route specified.
811 CTTOE3(A,I,K,E1,E2,E3) $VROUTEX(A,I,K,E1,E2,E3) =
812 CTTOE2(A,I,K,E1,E2,E3) +
813 (GTIME(A,'ENR') + (DIST(E2,E3)/SPD(A)))$DIST(E2,E3);
814
815 PARAMETER CTTOK(A,AF,AF,AF,AF,AF) ;
816 * Cumulative time (in hours) taken to travel from origin airfield
817 * to destination airfield (K) along the route specified.
818 CTTOK(A,I,K,E1,E2,E3) $VROUTEX(A,I,K,E1,E2,E3) =
819 CTTOE3(A,I,K,E1,E2,E3) +
820 (GTIME(A,'ENR') + (DIST(E3,K)/SPD(A)))$DIST(E3,K) ;
821
822 PARAMETER FLTTIME(A,I,K,E1,E2,E3) flight time (in 100 hrs) ;
823 * Gives the total flying hours consumed by an aircraft along a
824 * specified route.
825 FLTTIME(A,I,K,E1,E2,E3) $VROUTEX(A,I,K,E1,E2,E3) =
826 (DIST(I,E1) + DIST(E1,E2) + DIST(E2,E3)
827 + DIST(E3,K)) / (SPD(A) * 100) ;
828
829 PARAMETER RCTTOE3(A,AF,AF,AF,AF,AF) ;
830 * Cumulative time (in hours) taken to recover from destination
831 * airfield (K) to enroute airfield (E3) along the specified route
832 * inclusive of ground time. Note: (a) the route sequence is now
833 * from K to E3 to E2 to E1 to I. (b) the ordering of indices is
834 * preserved as such, as recommended by GAMS.
835 RCTTOE3(A,I,K,E1,E2,E3) $VROUTEY(A,I,K,E1,E2,E3) =

```

```

836     GTIME(A, 'OFFLD') + (DIST(E3,K)/SPD(A)) ;
837
838     PARAMETER RCTTOE2(A,AF,AF,AF,AF,AF) ;
839     * Cumulative time (in hours) taken to recover from destination
840     * airfield (K) to enrout airfield (E2) along the specified route
841     * inclusive of ground time.
842     RCTTOE2(A,I,K,E1,E2,E3) $VROUTEY(A,I,K,E1,E2,E3) =
843     RCTTOE3(A,I,K,E1,E2,E3) +
844     (GTIME(A, 'ENR') + (DIST(E2,E3)/SPD(A)))$DIST(E2,E3);
845
846     PARAMETER RCTTOE1(A,AF,AF,AF,AF,AF) ;
847     * Cumulative time (in hours) taken to recover from destination
848     * airfield (K) to enrout airfield (E1) along the specified route
849     * inclusive of ground time.
850     RCTTOE1(A,I,K,E1,E2,E3) $VROUTEY(A,I,K,E1,E2,E3) =
851     RCTTOE2(A,I,K,E1,E2,E3) +
852     (GTIME(A, 'ENR') + (DIST(E1,E2)/SPD(A)))$DIST(E1,E2);
853
854     PARAMETER RCTTOI(A,AF,AF,AF,AF,AF) ;
855     * Cumulative time (in hours) taken to recover from destination
856     * airfield (K) to origin airfield (I) along the specified route
857     * inclusive of ground time.
858     RCTTOI(A,I,K,E1,E2,E3) $VROUTEY(A,I,K,E1,E2,E3) =
859     RCTTOE1(A,I,K,E1,E2,E3) +
860     (GTIME(A, 'ENR') + (DIST(I,E1)/SPD(A)))$DIST(I,E1);
861
862     PARAMETER MOGREQ(AF,A) normalized (to NB) MOG requirement ;
863     * Normalized MOG requirement for an aircraft type to that of a
864     * narrow body aircraft for the airfield.
865     MOGREQ(AF,A) = MOGCAP(AF, 'NB') /
866     ( MOGCAP(AF, 'WB')$ACSIZE(A, 'WB') +
867     MOGCAP(AF, 'GM')$ACSIZE(A, 'GM') +
868     MOGCAP(AF, 'TT')$ACSIZE(A, 'TT') +
869     MOGCAP(AF, 'NB')$ACSIZE(A, 'NB') );
870
871     ***** LP VARIABLES *****
872
873     INTEGER VARIABLES
874
875     X(U,A,AF,AF,AF,AF,AF,T) number of airlift missions(aircraft) for
876     * unit (U), by aircraft (A), on the route
877     * specified with start time (T).
878
879     Y(A,AF,AF,AF,AF,AF,T) no. of aircraft (A) recovered to base (I)
880     * on the route specified with start
881     * time (T).
882
883     ALLOT(A,I,T) new aircraft made available allotted to base (I).
884
885     H(A,I,T) number of aircraft (A) saved for use at time T+1,
886     * at origin base (I), an end-of-period inventory.
887
888     HP(A,K,T) number of aircraft (A) that will start recovery ;
889     * from destination (K) in the next period instead of
890     * the current period.
891
892     POSITIVE VARIABLES
893
894     TONSUE(U,A,I,K,E1,E2,E3,T) unit U's equipment (in 100 tons)
895     * airlifted by aircraft (A) on the

```

```

896 *                               specified route with start time (T).
897
898   TPAX(U,A,I,K,E1,E2,E3,T)  number (in 100s) of unit U's troops
899 *                               airlifted by aircraft (A), on the
900 *                               specified route with start time (T).
901
902   UENOGO(U,I,K)             unit U's equipment (in 100 tons) not airlifted
903 *                               from the origin base (I) to destination (K)
904 *                               in the theater.
905
906   PAXNOGO(U,I,K)           number (in 100s) of unit U's troops not airlifted;
907 *                               from the origin base (I) to destination (K)
908 *                               in the theater.
909
910 FREE VARIABLE
911   Z   total penalty incurred from late deliveries and for not
912 *     fulfilling delivery requirement (undelivered cargoes).
913
914 ***** DYNAMIC SET DECLARATION *****
915
916 SET DSETX(U,A,AF,AF,AF,AF,AF,T) ;
917 * Used to control the allowable combination of unit, aircraft,
918 * route, and start time for the following decision variables:
919 * X(U,A,I,K,E1,E2,E3,T), TONSUE(U,A,I,K,E1,E2,E3,T) and
920 * TPAX(U,A,I,K,E1,E2,E3,T). A valid combination implies that the
921 * following be satisfied: Start time for delivery must be after an
922 * unit's ALD and delivery date must be before the RDD plus the
923 * maximum allowed lateness. There is movement requirement.
924 * Maximum aircraft payload for the route must be greater than 25%
925 * its full load capability; this is for cost efficiency. Supply
926 * of aircraft type to date must be greater than 0.
927   DSETX(U,VROUTEX(A,I,K,E1,E2,E3),T) = YES $(
928     (ORD(T) GE ALD(U)) AND
929     (ORD(T) LE (RDD(U) - ROUND(CITOK(VROUTEX)/24) + MAXLATE))
930     AND (1$MOVEUE(U,I,K) OR 1$MOVEPAX(U,I,K))
931     AND (1$(MAXLOAD(VROUTEX) GT (0.25 * ACLOAD(A,"1"))) ) )
932     and SUM (TP$(ORD(TP) LE ORD(T)), SUPPLY(A,TP))
933   ) ;
934
935 SET DSETY(A,AF,AF,AF,AF,AF,T) ;
936 * Used to control the allowable combination of aircraft,
937 * route, and start time for the decision variable
938 * Y(U,A,I,K,E1,E2,E3,T). An allowable combination is one
939 * in which the aircraft-route is compatible and that the supply
940 * of aircraft type to date is greater than 0.
941   DSETY(VROUTEX(A,I,K,E1,E2,E3),T) = YES $(
942     SUM (TP$(ORD(TP) LE ORD(T)), SUPPLY(A,TP))
943   ) ;
944
945 ***** LP EQUATION DEFINITIONS *****
946
947 EQUATIONS
948
949   OBJFUN   define objective function
950   REQMTUE(U,I,K)  movement requirement for UE
951   OUTREQMT(U,I,K)  out-sized cargo requirement
952   OVERREQMT(U,I,K)  over-sized cargo requirement
953   REQMTTPAX(U,I,K)  movement requirement for troops
954   ACBALI(A,I,T)   aircraft balance equation at origins
955   ACALLOT(A,T)   aircraft allocation balance equation

```

```

956 ACBALK(A,K,T) aircraft balance equation at destinations
957 ACWEIGHT(U,A,I,K,E1,E2,E3,T) aircraft payload limitation
958 ACSPACE(U,A,I,K,E1,E2,E3,T) aircraft cargo space limitation
959 ACPAX(U,A,I,K,E1,E2,E3,T) aircraft PAX carriage limitation
960 ACURATE(A) utilization rate constraint
961 MOGUTILITY(AF,T) handling capacity of airfields ;
962
963 ***** OBJECTIVE FUNCTION *****
964
965 OBJFUN. .
966 Z =E= SUM ( (U,A,I,K,E1,E2,E3,T) $DSETX(U,A,I,K,E1,E2,E3,T),
967 (TONSUE(U,A,I,K,E1,E2,E3,T)$ACSQFT(A) * LATEPEN(U,'UE') *
968 MAX(0, ORD(T)+ROUND(CTTOK(A,I,K,E1,E2,E3)/24)-RDD(U)) ) +
969 (TPAX(U,A,I,K,E1,E2,E3,T) * LATEPEN(U,'PAX') *
970 MAX(0, ORD(T)+ROUND(CTTOK(A,I,K,E1,E2,E3)/24)-RDD(U)) ) )
971 + SUM ( (U,I,K) $(1$MOVEUE(U,I,K) OR 1$MOVEPAX(U,I,K)),
972 (UENOGO(U,I,K)*NOGOPEN(U,'UE')) +
973 (PAXNOGO(U,I,K)*NOGOPEN(U,'PAX')) ) ;
974
975 ***** DEMAND SATISFACTION CONSTRAINTS *****
976
977
978 * Total tonnage (in 100 tons) of unit equipment delivered to the
979 * theater by all aircraft types flying all routes over all time
980 * periods plus total tonnage (in 100 tons) of equipment not
981 * delivered must be greater than or equal to the movement
982 * requirement for unit equipment.
983
984 REQMTUE(U,I,K) $MOVEUE(U,I,K)..
985 SUM ( (A,E1,E2,E3) $ACCARGO(A,'BULK'),
986 SUM ( T $DSETX(U,A,I,K,E1,E2,E3,T), TONSUE(U,A,I,K,E1,E2,E3,T) ) )
987 + UENOGO(U,I,K) =G= MOVEUE(U,I,K) ;
988
989 * Total tonnage (in 100 tons) of unit equipment carried by out-
990 * sized cargo capable aircraft plus tonnage of unit equipment
991 * not delivered (UENOGO) must be greater than or equal to the
992 * movement requirement for out-sized cargo (given by the
993 * proportion of out-sized cargo multiplied by the movement
994 * requirement for unit equipment).
995
996 OUTREQMT(U,I,K) $MOVEUE(U,I,K)..
997 SUM ( (A,E1,E2,E3) $ACCARGO(A,'OUT'),
998 SUM ( T $DSETX(U,A,I,K,E1,E2,E3,T), TONSUE(U,A,I,K,E1,E2,E3,T) ) )
999 + UENOGO(U,I,K) =G= CARGOP(U,'OUT') * MOVEUE(U,I,K) ;
1000
1001 * Total tonnage (in 100 tons) of unit equipment carried by over-
1002 * sized cargo capable aircraft plus tonnage of unit equipment
1003 * not delivered (UENOGO) must be greater than or equal to the
1004 * movement requirement for over-sized and out-sized cargoes
1005 * (given by the proportion of out-sized cargo + proportion of
1006 * over-sized cargo multiplied by the movement requirement for
1007 * unit equipment). This constraint is set up as such because an
1008 * out-sized carrier can be used to carry over-sized cargo.
1009
1010 OVERREQMT(U,I,K) $MOVEUE(U,I,K)..
1011 SUM ( (A,E1,E2,E3) $ACCARGO(A,'OVER'),
1012 SUM ( T $DSETX(U,A,I,K,E1,E2,E3,T), TONSUE(U,A,I,K,E1,E2,E3,T) ) )
1013 + UENOGO(U,I,K)
1014 =G= ( CARGOP(U,'OVER') + CARGOP(U,'OUT') ) * MOVEUE(U,I,K) ;
1015
1016 * Total number (in 100s) of troops airlifted to the theater plus

```

```

1015 * those not airlifted must be greater than or equal to the
1016 * movement requirement for troops.
1017
1018 REQTPAX(U,I,K) $MOVEPAX(U,I,K)..
1019 SUM ( (A,E1,E2,E3),
1020 SUM ( T $DSETX(U,A,I,K,E1,E2,E3,T), TPAX(U,A,I,K,E1,E2,E3,T) ) )
1021 + PAXNOGO(U,I,K) =G= MOVEPAX(U,I,K) ;
1022
1024 ***** AIRCRAFT BALANCE CONSTRAINTS *****
1025
1026 * Aircraft balance constraint at origin airfields. On each day,
1027 * the total number of aircraft assigned for airlift missions plus
1028 * aircraft inventoried must be equal to the number of aircraft
1029 * available from the last period plus new supply of a/c allocated
1030 * to the base and aircraft that return from previous missions.
1031
1033 ACBALI(A,I,T)..
1034 SUM ( (U,K,E1,E2,E3) $DSETX(U,A,I,K,E1,E2,E3,T),
1035 X(U,A,I,K,E1,E2,E3,T) ) + H(A,I,T)
1036 =E= H(A,I,T-1) $(ORD(T) GT 1) + ALLOT(A,I,T) $SUPPLY(A,T) +
1037 SUM ( (K,E1,E2,E3),
1038 SUM ( TP $(
1039 $DSETY(A,I,K,E1,E2,E3,TP) AND
1040 1$( (ORD(TP)+ROUND(RCTTOI(A,I,K,E1,E2,E3)/24)) EQ ORD(T)) ,
1041 Y(A,I,K,E1,E2,E3,TP) ) ) ;
1042
1042 * The sum of aircraft (newly made available) allocated to the
1043 * different origin bases each day must be less than or equal
1044 * to the number of aircraft actually made available.
1045
1046 ACALLOT(A,T) $SUPPLY(A,T).. SUM(I, ALLOT(A,I,T)) =L= SUPPLY(A,T) ;
1047
1048 * Aircraft balance constraint at destination airfields. On each
1049 * day, the number of each type of aircraft returning plus
1050 * those that will return in the next period from a destination
1051 * airfield must be equal to those waiting to return plus new
1052 * arrivals at the destination.
1053
1054 ACBALK(A,K,T)..
1055 SUM ( (I,E1,E2,E3) $DSETY(A,I,K,E1,E2,E3,T),
1056 Y(A,I,K,E1,E2,E3,T) ) + HP(A,K,T)
1057 =E= HP(A,K,T-1) $(ORD(T) GT 1) +
1058 SUM ( (U,I,E1,E2,E3),
1059 SUM (
1060 TP$( (ORD(TP)+ROUND(CTTOK(A,I,K,E1,E2,E3)/24)) EQ ORD(T))
1061 AND 1$DSETX(U,A,I,K,E1,E2,E3,TP) ) ,
1062 X(U,A,I,K,E1,E2,E3,TP) ) ) ;
1063
1065 ***** AIRCRAFT PHYSICAL LIMITATION CONSTRAINTS *****
1066
1067 * Payload limitation: Total weight (equipment and men) carried
1068 * by aircraft (A) on each route must be less than the critical
1069 * payload for the route multiplied by the number of aircraft
1070 * assigned for airlift missions.
1071
1072 ACWEIGHT(U,A,I,K,E1,E2,E3,T) $DSETX(U,A,I,K,E1,E2,E3,T)..
1073 TONSUE(U,A,I,K,E1,E2,E3,T) + PAXWT*TPAX(U,A,I,K,E1,E2,E3,T)
1074 =L= MAXLOAD(A,I,K,E1,E2,E3) * X(U,A,I,K,E1,E2,E3,T) ;
1075
1076 * Cargo Space limitation: The total cargo space taken up by men

```

1077 * and equipment carried by aircraft (A) on each route must be
1078 * less than the cargo space of the aircraft multiplied by the
1079 * aircraft loading efficiency and the number of aircraft
* assigned for airlift missions.
1080
1081 ACSPACE(U, A, I, K, E1, E2, E3, T)
* (ACSQFT(A) \$DSETX(U, A, I, K, E1, E2, E3, T)) ..
1082 (PAXSQFT(A) * TPAX(U, A, I, K, E1, E2, E3, T)) +
1083 (UESQFT(U) * TONSUE(U, A, I, K, E1, E2, E3, T))
1084 =L= ACSQFT(A) * LOADEFF(A) * X(U, A, I, K, E1, E2, E3, T) ;
1085
1086 * PAX carriage limitation: The total number of troops carried by
1087 * aircraft (A) on each route must not be greater than the troop
1088 * carriage capacity of the aircraft type multiplied by the number
1089 * of aircraft assigned for airlift missions.
1090
1091 ACPAX(U, A, I, K, E1, E2, E3, T) \$DSETX(U, A, I, K, E1, E2, E3, T) ..
1092 TPAX(U, A, I, K, E1, E2, E3, T) =L= MAXPAX(A) * X(U, A, I, K, E1, E2, E3, T) ;
1093
1094 * Cargo space limitation.
1095
1097 ***** AIRCRAFT UTILIZATION RATE CONSTRAINTS *****
1098
1099 * The total number of flying hours (in 100s) consumed by each
1100 * aircraft type must be less than the utilization rate (in 100 hrs
1101 * per aircraft per day) times the number of aircraft initially
1102 * made available on day (T) times the remaining time periods where
1103 * these aircraft could be used. The productive time periods for
1104 * an aircraft made available on day (T) is equal to the total time
1105 * periods (CARD(T)) plus 1 minus ORD(T). For example, if the
1106 * total time periods of concern is 10, then an aircraft initially
1107 * made available on day 1 could be used for 10 days.
1108
1109 ACURATE(A) ..
1110 SUM ((U, I, K, E1, E2, E3, T) \$DSETX(U, A, I, K, E1, E2, E3, T) ,
1111 X(U, A, I, K, E1, E2, E3, T) * FLTTIME(A, I, K, E1, E2, E3)) +
1112 SUM ((I, K, E1, E2, E3, T) \$DSETY(A, I, K, E1, E2, E3, T) ,
1113 Y(A, I, K, E1, E2, E3, T) * FLTTIME(A, I, K, E1, E2, E3))
1114 =L= SUM (T \$SUPPLY(A, T) ,
1115 URATE(A) * (CARD(T)+1-ORD(T)) * SUPPLY(A, T)) ;
1116
1118 ***** AIRCRAFT HANDLING CAPACITY OF AIRFIELD (MOG CONSTRAINT) *****
1119
1120 * These constraints model the throughput or handling capacity of
1121 * an airfield; i.e., it will limit the number of aircraft using
1122 * the airfield each day. As an airfield can serve as an origin,
1123 * enroute, or destination, the total MOG consumed for each day
1124 * would be a sum of individual consumptions. This total must not
1125 * be greater than the MOG efficiency factor multiplied by the MOG
1126 * capacity (scaled to narrow body aircraft for comparison) of that
1127 * airfield. A MOG efficiency factor is used as it is recognised
1128 * that it is virtually impossible for an airfield to be running
1129 * at full capacity for the whole day given the stochastic nature
1130 * aircraft ground times. Unless aircraft can be sequenced to
1131 * arrive at an airfield precisely one after another, congestion
1131 * can occur and the effective MOG utilization will be below the
1132 * MOG capacity of the airfield. As an origin airfield, MOG
1133 * consumed is equal to the total number of aircraft assigned for
1134 * airlift missions scaled by the MOGREQ (normalize MOG
1135 * requirement of aircraft) and the proportion of time (per day)

```

1136 * spent on a MOG spot. Proportion of time spent is equal to the
1137 * on-load time divided by 24 in this case. As an enroute
1138 * airfield, the MOG consumed is equal to the total number of
1139 * aircraft making enroute stops scaled by the MOGREQ factor and
1140 * the proportion of time spent on a MOG spot (enroute ground time
1141 * divided by 24). The MOG consumption when the airfield serves
1142 * as a destination is computed in a similar manner except that
1143 * the proportion of time spent is equal to the off-load time
1144 * divided by 24. To prevent double counting of MOG consumption,
1145 * conditional checks are done for enroute airfields. These are:
1146 * i. Valid combination of indices (member of DSETX or DSETY)
1147 * ii. Time of arrival is the period of concern
1148 * iii. The aircraft came from somewhere (distance between the
1149 * previous and current airfield is not equal to 0)
1150 * iv. Time to enroute airfield is not equal to time to origin
1151 * or destination airfield
1152 MOGUTILITY(AF,T) ..
1153
1154 SUM ( (U,A,K,E1,E2,E3) $DSETX(U,A,AF,K,E1,E2,E3,T) ,
1155 X(U,A,AF,K,E1,E2,E3,T) * MOGREQ(AF,A) * GTIME(A,'ONLD') / 24 )
1156 * MOG utilization when used as an origin airfield (I)
1157
1158 +
1159 SUM ( (U,A,I,K,E2,E3,TP) $(
1160 1$DSETX(U,A,I,K,AF,E2,E3,TP) AND
1161 1$(ORD(TP)+ROUND(CTTOE1(A,I,K,AF,E2,E3)/24) EQ ORD(T)) AND
1162 1$DIST(I,AF) AND
1163 1$(CTTOE1(A,I,K,AF,E2,E3) NE CTTOI(A,I,K,AF,E2,E3)) ) ,
1164 X(U,A,I,K,AF,E2,E3,TP) * MOGREQ(AF,A) * GTIME(A,'ENR') / 24 )
1165
1166 + SUM ( (A,I,K,E2,E3,TP) $(
1167 1$DSETY(A,I,K,AF,E2,E3,TP) AND
1168 1$(ORD(TP)+ROUND(RCTTOE1(A,I,K,AF,E2,E3)/24) EQ ORD(T)) AND
1169 1$DIST(AF,E2) AND
1170 1$(RCTTOE1(A,I,K,AF,E2,E3) NE RCTTOI(A,I,K,AF,E2,E3)) ) ,
1171 Y(A,I,K,AF,E2,E3,TP) * MOGREQ(AF,A) * GTIME(A,'ENR') / 24 )
1172 * MOG utilization when used as an E1 airfield
1173
1174 +
1175 SUM ( (U,A,I,K,E1,E3,TP) $(
1176 1$DSETX(U,A,I,K,E1,AF,E3,TP) AND
1177 1$(ORD(TP)+ROUND(CTTOE2(A,I,K,E1,AF,E3)/24) EQ ORD(T)) AND
1178 1$DIST(E1,AF) AND
1179 1$(CTTOE2(A,I,K,E1,AF,E3) NE CTTOI(A,I,K,E1,AF,E3)) ) ,
1180 X(U,A,I,K,E1,AF,E3,TP) * MOGREQ(AF,A) * GTIME(A,'ENR') / 24 )
1181
1182 + SUM ( (A,I,K,E1,E3,TP) $(
1183 1$DSETY(A,I,K,E1,AF,E3,TP) AND
1184 1$(ORD(TP)+ROUND(RCTTOE2(A,I,K,E1,AF,E3)/24) EQ ORD(T)) AND
1185 1$DIST(AF,E3) AND
1186 1$(RCTTOE2(A,I,K,E1,AF,E3) NE RCTTOI(A,I,K,E1,AF,E3)) ) ,
1187 Y(A,I,K,E1,AF,E3,TP) * MOGREQ(AF,A) * GTIME(A,'ENR') / 24 )
1188 * MOG utilization when used as an E2 airfield
1189
1190 +
1191 SUM ( (U,A,I,K,E1,E2,TP) $(
1192 1$DSETX(U,A,I,K,E1,E2,AF,TP) AND
1193 1$(ORD(TP)+ROUND(CTTOE3(A,I,K,E1,E2,AF)/24) EQ ORD(T)) AND
1194 1$DIST(E2,AF) AND

```

```

1195     1$(CTTOE3(A,I,K,E1,E2,AF) NE CTTOK(A,I,K,E1,E2,AF)) ),
1196     X(U,A,I,K,E1,E2,AF,TP) * MOGREQ(AF,A) * GTIME(A,'ENR') / 24 )
1197
1198 + SUM ( (A,I,K,E1,E2,TP) $(
1199     1$DSETY(A,I,K,E1,E2,AF,TP) AND
1200     1$(ORD(TP)+ROUND(RCTTOE3(A,I,K,E1,E2,AF)/24) EQ ORD(T)) AND
1201     1$DIST(AF,K) AND
1202     1$(RCTTOE3(A,I,K,E1,E2,AF) NE RCTTOI(A,I,K,E1,E2,AF)) ),
1203     Y(A,I,K,E1,E2,AF,TP) * MOGREQ(AF,A) * GTIME(A,'ENR') / 24 )
1204 * MOG utilization when used as an E3 airfield
1205
1206 +
1207 SUM ( (U,A,I,E1,E2,E3,TP) $(
1208     1$DSETX(U,A,I,AF,E1,E2,E3,TP) AND
1209     1$(ORD(TP)+ROUND(CTTOK(A,I,AF,E1,E2,E3)/24) EQ ORD(T)) ),
1210     X(U,A,I,AF,E1,E2,E3,TP) * MOGREQ(AF,A) * GTIME(A,'OFFLD') / 24 )
1211 * MOG utilization when used as a destination airfield (K)
1212
1213     =L= MOGEFF * MOGCAP(AF,'NB') ;
1214
1215
1216 MODEL AIRLIFT /ALL/;
1217
1218 SOLVE AIRLIFT using RMIP minimizing Z ;

```

Include File Summary

GLOBAL	TYPE	LOCAL	FILE NAME
0	INPUT	0	/home/limt/airlift6.gms
24	INCLUDE	24	./home/limt/unitname.dat
49	INCLUDE	27	./home/limt/acname.dat
61	INCLUDE	30	./home/limt/craf.dat
69	INCLUDE	33	./home/limt/milac.dat
89	INCLUDE	47	./home/limt/periods.dat
107	INCLUDE	59	./home/limt/afname.dat
130	INCLUDE	62	./home/limt/orgname.dat
139	INCLUDE	65	./home/limt/destname.dat
147	INCLUDE	68	./home/limt/e1name.dat
162	INCLUDE	71	./home/limt/e2name.dat
175	INCLUDE	74	./home/limt/e3name.dat
190	INCLUDE	81	./home/limt/vroutex.set
237	INCLUDE	84	./home/limt/vroutey.set
267	INCLUDE	91	./home/limt/moveue.dat
298	INCLUDE	98	./home/limt/cargop.dat
323	INCLUDE	102	./home/limt/movepax.dat
350	INCLUDE	105	./home/limt/ald.dat
375	INCLUDE	108	./home/limt/rdd.dat
400	INCLUDE	111	./home/limt/maxlate.dat
407	INCLUDE	115	./home/limt/latepen.dat
439	INCLUDE	123	./home/limt/nogopen.dat
445	INCLUDE	128	./home/limt/uesqft.dat
478	INCLUDE	138	./home/limt/acsupply.dat
507	INCLUDE	142	./home/limt/acsize.dat
520	INCLUDE	146	./home/limt/accargo.dat
533	INCLUDE	150	./home/limt/acmaxpax.dat
547	INCLUDE	154	./home/limt/paxsqft.dat
564	INCLUDE	158	./home/limt/acsqft.dat
579	INCLUDE	162	./home/limt/loadeff.dat

```

595 INCLUDE      166 ./home/limt/acspeed.dat
608 INCLUDE      170 ./home/limt/gtime.dat
621 INCLUDE      175 ./home/limt/uxrate.dat
644 INCLUDE      188 ./home/limt/acrange.dat
656 INCLUDE      192 ./home/limt/acload.dat
682 INCLUDE      209 ./home/limt/afcoord.dat
709 INCLUDE      218 ./home/limt/mogcap.dat
735 INCLUDE      226 ./home/limt/mogeff.dat

```

COMPILATION TIME = 0.680 SECONDS VERID AIX-00-064

Model Statistics SOLVE AIRLIFT USING RMIP FROM LINE 1218

MODEL STATISTICS

```

BLOCKS OF EQUATIONS      13      SINGLE EQUATIONS      6349
BLOCKS OF VARIABLES      10      SINGLE VARIABLES      8723
NON ZERO ELEMENTS      38614      DISCRETE VARIABLES      5500

```

GENERATION TIME = 42.590 SECONDS

EXECUTION TIME = 44.700 SECONDS VERID AIX-00-064

```

STEP SUMMARY:      0.010 STARTUP
                   0.680 COMPILATION
                   44.700 EXECUTION
                   0.090 CLOSEDOWN
                   45.480 TOTAL SECONDS

```

Solution Report SOLVE AIRLIFT USING RMIP FROM LINE 1218

S O L V E S U M M A R Y

```

MODEL AIRLIFT      OBJECTIVE Z
TYPE RMIP          DIRECTION MINIMIZE
SOLVER OSL         FROM LINE 1218

```

```

**** SOLVER STATUS      1 NORMAL COMPLETION
**** MODEL STATUS      1 OPTIMAL
**** OBJECTIVE VALUE          37.0139

```

```

RESOURCE USAGE, LIMIT      28.690      18000.000
ITERATION COUNT, LIMIT     3001        400000

```

OSL Release 2, GAMS Link level 3 --- AIX RS/6000 1.3.045-017

Work space allocated -- 5.54 Mb

```

**** REPORT SUMMARY :      0 NONOPT
                           0 INFEASIBLE
                           0 UNBOUNDED

```

EXECUTION TIME = 0.230 SECONDS VERID AIX-00-064

USER: Operations Research Department
Naval Postgraduate School

G940405-1442AX-AIX

**** FILE SUMMARY

INPUT /home/limt/airlift6.gms
OUTPUT /home/limt/airlift6.lst
SAVE /home/limt/final.g0?

**** WARNING - COMPILER OPTIONS ARE NON DEFAULT
INLINECOM { }

STEP SUMMARY: 0.180 STARTUP
 0.000 COMPILATION
 0.230 EXECUTION
 0.150 CLOSEDOWN
 0.560 TOTAL SECONDS

```

1219
1220 ***** SUMMARY REPORTS *****
1221
1222 ***** DEMAND SATISFACTION *****
1223
1224 PARAMETER TONSONT(U,I,K)    unit U's equipment (in 100 tons)
*                               delivered on time;
1225     TONSONT(U,I,K) $MOVEUE(U,I,K)
1226     = SUM( (A,E1,E2,E3,T) ,
1227           TONSUE.L(U,A,I,K,E1,E2,E3,T)
1228           $( (ORD(T)+ROUND(CTTOK(A,I,K,E1,E2,E3)/24) LE RDD(U) )
1229             $DSETX(U,A,I,K,E1,E2,E3,T) )
1230     );
1231
1232 PARAMETER TONSLATE(U,I,K)   unit U's equipment (in 100 tons)
*                               delivered late;
1233     TONSLATE(U,I,K) $MOVEUE(U,I,K)
1234     = SUM( (A,E1,E2,E3,T) ,
1235           TONSUE.L(U,A,I,K,E1,E2,E3,T)
1236           $( (ORD(T)+ROUND(CTTOK(A,I,K,E1,E2,E3)/24) GT RDD(U) )
1237             $DSETX(U,A,I,K,E1,E2,E3,T) )
1238     );
1239
1240
1241 PARAMETER PAXONT(U,I,K)     number (in 100s) of unit U's troops
*                               airlifted on time;
1242     PAXONT(U,I,K) $MOVEPAX(U,I,K)
1243     = SUM( (A,E1,E2,E3,T) ,
1244           TPAX.L(U,A,I,K,E1,E2,E3,T)
1245           $( (ORD(T)+ROUND(CTTOK(A,I,K,E1,E2,E3)/24) LE RDD(U) )
1246             $DSETX(U,A,I,K,E1,E2,E3,T) )
1247     );
1248
1249 PARAMETER PAXLATE(U,I,K)    number (in 100s) of unit U's troops
*                               airlifted late;
1250     PAXLATE(U,I,K) $MOVEPAX(U,I,K)
1251     = SUM( (A,E1,E2,E3,T) ,
1252           TPAX.L(U,A,I,K,E1,E2,E3,T)
1253           $( (ORD(T)+ROUND(CTTOK(A,I,K,E1,E2,E3)/24) GT RDD(U) )
1254             $DSETX(U,A,I,K,E1,E2,E3,T) )
1255     );
1256
1257 OPTION TONSONT:2:0:3;
1258 DISPLAY TONSONT;
1259 OPTION TONSLATE:2:0:3;
1260 DISPLAY TONSLATE;
1261 OPTION UENOGO:2:0:3;
1262 DISPLAY UENOGO.L;
1263 OPTION PAXONT:2:0:3;
1264 DISPLAY PAXONT;
1265 OPTION PAXLATE:2:0:3;
1266 DISPLAY PAXLATE;
1267 OPTION PAXNOGO:2:0:3;
1268 DISPLAY PAXNOGO.L;
1269
1270 ***** AIRCRAFT UTILIZATION RATE *****
1271
1272 PARAMETER ACTUALUR(A)       actual utilization rate (in hrs per day per
*                               aircraft);
1273     ACTUALUR(A) =

```

```

1274      ( SUM ( (U,I,K,E1,E2,E3,T) $DSETX(U,A,I,K,E1,E2,E3,T) ,
1275              X.L(U,A,I,K,E1,E2,E3,T) * FLTTIME(A,I,K,E1,E2,E3) ) +
1276      SUM ( (I,K,E1,E2,E3,T) $DSETY(A,I,K,E1,E2,E3,T) ,
1277              Y.L(A,I,K,E1,E2,E3,T) * FLTTIME(A,I,K,E1,E2,E3) ) ) * 100
1278      / SUM ( T, ( CARD(T)+1-ORD(T) ) * SUPPLY(A,T) $SUPPLY(A,T) );
1279 DISPLAY ACTUALUR;
1280
1281 ***** MOG CONSUMPTION *****
1282
1283 * Reports the MOG consumption of an airfield. If you set the MOG
1284 * efficiency factor to 0.9, and the percentage of MOG capacity
1285 * used, MOGUSED(AF,T), is 90, then it means that the airfield has
1286 * "MOGed" out; i.e., the airfield's aircraft handling capacity is
1287 * a binding constraint.
1288
1288 PARAMETER MOGUSED(AF,T) percentage of MOG capacity used ;
1289 MOGUSED(AF,T) = (
1290     SUM ( (U,A,K,E1,E2,E3) $DSETX(U,A,AF,K,E1,E2,E3,T) ,
1291           X.L(U,A,AF,K,E1,E2,E3,T) * MOGREQ(AF,A) * GTIME(A,'ONLD') / 24 )
1292 * MOG utilization when used as an origin airfield (I)
1293
1294 +
1295     SUM ( (U,A,I,K,E2,E3,TP) $(
1296           1$DSETX(U,A,I,K,AF,E2,E3,TP) AND
1297           1$(ORD(TP)+ROUND(CTTOE1(A,I,K,AF,E2,E3)/24) EQ ORD(T)) AND
1298           1$DIST(I,AF) AND
1299           1$(CTTOE1(A,I,K,AF,E2,E3) NE CTTOK(A,I,K,AF,E2,E3)) ) ,
1300           X.L(U,A,I,K,AF,E2,E3,TP) * MOGREQ(AF,A) * GTIME(A,'ENR') / 24 )
1301
1302 + SUM ( (A,I,K,E2,E3,TP) $(
1303           1$DSETY(A,I,K,AF,E2,E3,TP) AND
1304           1$(ORD(TP)+ROUND(RCTTOE1(A,I,K,AF,E2,E3)/24) EQ ORD(T)) AND
1305           1$DIST(AF,E2) AND
1306           1$(RCTTOE1(A,I,K,AF,E2,E3) NE RCTTOI(A,I,K,AF,E2,E3)) ) ,
1307           Y.L(A,I,K,AF,E2,E3,TP) * MOGREQ(AF,A) * GTIME(A,'ENR') / 24 )
1308 * MOG utilization when used as an E1 airfield
1309
1310 +
1311     SUM ( (U,A,I,K,E1,E3,TP) $(
1312           1$DSETX(U,A,I,K,E1,AF,E3,TP) AND
1313           1$(ORD(TP)+ROUND(CTTOE2(A,I,K,E1,AF,E3)/24) EQ ORD(T)) AND
1314           1$DIST(E1,AF) AND
1315           1$(CTTOE2(A,I,K,E1,AF,E3) NE CTTOK(A,I,K,E1,AF,E3)) ) ,
1316           X.L(U,A,I,K,E1,AF,E3,TP) * MOGREQ(AF,A) * GTIME(A,'ENR') / 24 )
1317
1318 + SUM ( (A,I,K,E1,E3,TP) $(
1319           1$DSETY(A,I,K,E1,AF,E3,TP) AND
1320           1$(ORD(TP)+ROUND(RCTTOE2(A,I,K,E1,AF,E3)/24) EQ ORD(T)) AND
1321           1$DIST(AF,E3) AND
1322           1$(RCTTOE2(A,I,K,E1,AF,E3) NE RCTTOI(A,I,K,E1,AF,E3)) ) ,
1323           Y.L(A,I,K,E1,AF,E3,TP) * MOGREQ(AF,A) * GTIME(A,'ENR') / 24 )
1324 * MOG utilization when used as an E2 airfield
1325
1326 +
1327     SUM ( (U,A,I,K,E1,E2,TP) $(
1328           1$DSETX(U,A,I,K,E1,E2,AF,TP) AND
1329           1$(ORD(TP)+ROUND(CTTOE3(A,I,K,E1,E2,AF)/24) EQ ORD(T)) AND
1330           1$DIST(E2,AF) AND
1331           1$(CTTOE3(A,I,K,E1,E2,AF) NE CTTOK(A,I,K,E1,E2,AF)) ) ,
1332           X.L(U,A,I,K,E1,E2,AF,TP) * MOGREQ(AF,A) * GTIME(A,'ENR') / 24 )

```

```

1333
1334 + SUM ( (A,I,K,E1,E2,TP) $(
1335 1$DSETY(A,I,K,E1,E2,AF,TP) AND
1336 1$(ORD(TP)+ROUND(RCTTOE3(A,I,K,E1,E2,AF)/24) EQ ORD(T)) AND
1337 1$DIST(AF,K) AND
1338 1$(RCTTOE3(A,I,K,E1,E2,AF) NE RCTTOI(A,I,K,E1,E2,AF)) ),
1339 Y.L(A,I,K,E1,E2,AF,TP) * MOGREQ(AF,A) * GTIME(A,'ENR') / 24 )
1340 * MOG utilization when used as an E3 airfield
1341
1342 +
1343 SUM ( (U,A,I,E1,E2,E3,TP) $(
1344 1$DSETX(U,A,I,AF,E1,E2,E3,TP) AND
1345 1$(ORD(TP)+ROUND(CTTOK(A,I,AF,E1,E2,E3)/24) EQ ORD(T)) ),
1346 X.L(U,A,I,AF,E1,E2,E3,TP)*MOGREQ(AF,A)*GTIME(A,'OFFLD') / 24 )
1347 * MOG utilization when used as a destination airfield (K)
1348
1349 / MOGCAP(AF,'NB') * 100 ;
1350
1351 OPTION MOGUSED:2:0:4;
1352 DISPLAY MOGUSED;
1353
1354 *+++++ AIRCRAFT ALLOCATION AND MISSION ASSIGNMENTS ++++++
1355
1356 OPTION ALLOT:2:0:2;
1357 DISPLAY ALLOT.L;
1358 OPTION X:2:0:1;
1359 DISPLAY X.L;
1360 OPTION Y:2:0:1;
1361 DISPLAY Y.L;
1362 OPTION TONSUE:2:0:1;
1363 DISPLAY TONSUE.L;
1364 OPTION TPAX:2:0:1;
1365 DISPLAY TPAX.L;
1366

```

COMPILATION TIME = 0.060 SECONDS VERID AIX-00-064

---- 1258 PARAMETER TONSONT unit U's equipment (in 100 tons)
delivered on time

UNITA.XDAT.FFTJ	79.02,	UNITB.TYFR.FFTJ	6.92,	UNITD.TMKH.FFTJ	114.94
UNITE.TYFR.UGZX	27.96,	UNITF.TMKH.UGZX	183.96,	UNITG.TYFR.UGZX	5.03
UNITH.XDAT.UGZX	3.01,	UNITL.TYFR.UGZX	4.91,	UNITM.TYFR.UGZX	3.24
UNITN.TYFR.UGZX	5.03,	UNITO.TYFR.PKVV	3.07,	UNITP.TYFR.PKVV	5.22
UNITQ.TMKH.PKVV	9.59,	UNITR.TMKH.UGZX	10.13,	UNITS.TMKH.UGZX	10.13
UNITT.XDAT.UGZX	4.78				

---- 1260 PARAMETER TONSLATE unit U's equipment (in 100 tons)
delivered late

UNITC.XDAT.FFTJ	42.35,	UNITF.TMKH.UGZX	54.31,	UNITH.XDAT.UGZX	7.12
UNITI.QFQE.UGZX	5.03,	UNITJ.XDAT.UGZX	10.13,	UNITK.TYFR.UGZX	5.03
UNITM.TYFR.UGZX	1.98,	UNITO.TYFR.PKVV	1.84,	UNITQ.TMKH.PKVV	0.54
UNITT.XDAT.UGZX	5.35				

---- 1262 VARIABLE UENOGO.L unit U's equipment (in 100 tons) that
are not airlifted

UNITA.XDAT.FFTJ 107.75, UNITC.XDAT.FFTJ 20.88, UNITE.TYFR.UGZX 635.73

UGZX.DAY11	90.00,	UGZX.DAY12	90.00,	UGZX.DAY13	90.00,	UGZX.DAY14	90.00
UGZX.DAY15	90.00,	UGZX.DAY16	90.00,	UGZX.DAY17	90.00,	UGZX.DAY18	90.00
UGZX.DAY19	90.00,	UGZX.DAY20	90.00,	UGZX.DAY21	90.00,	UGZX.DAY22	90.00
UGZX.DAY26	5.23,	UGZX.DAY28	31.35,	PKVV.DAY5	90.00,	PKVV.DAY6	90.00
PKVV.DAY7	90.00,	PKVV.DAY8	3.28,	KNMD.DAY7	0.73,	KNMD.DAY18	3.00
KNMD.DAY19	6.00,	FXSB.DAY7	4.03,	FXSB.DAY8	7.50,	FXSB.DAY9	8.06
FXSB.DAY11	4.03,	WWYK.DAY13	4.69,	WWYK.DAY14	43.74,	WWYK.DAY15	16.34
WWYK.DAY17	53.02,	WWYK.DAY18	50.16,	WWYK.DAY19	50.01,	WWYK.DAY20	27.64
WWYK.DAY21	90.00,	WWYK.DAY22	9.37,	WWYK.DAY24	56.25,	WWYK.DAY25	26.96
NNGX.DAY6	11.45,	NNGX.DAY7	12.36,	NNGX.DAY8	11.45,	NNGX.DAY9	4.61
NNGX.DAY10	1.35,	NNGX.DAY11	25.63,	NNGX.DAY13	25.63,	NNGX.DAY14	10.09
NNGX.DAY15	18.75,	NNGX.DAY16	59.42,	NNGX.DAY17	43.68,	NNGX.DAY20	25.71
NNGX.DAY22	51.43,	UTKY.DAY7	4.61,	UTKY.DAY8	2.88,	UTKY.DAY10	1.35
UTKY.DAY13	25.71,	UTKY.DAY14	21.11,	UTKY.DAY15	25.71,	UTKY.DAY16	25.71
UTKY.DAY17	25.71,	UTKY.DAY20	25.71,	UTKY.DAY21	12.86,	ZNRE.DAY7	8.65
ZNRE.DAY8	8.02,	ZNRE.DAY9	6.45,	ZNRE.DAY10	0.94,	ZNRE.DAY11	3.22
ZNRE.DAY13	21.22,	ZNRE.DAY14	14.78,	ZNRE.DAY15	18.00,	ZNRE.DAY16	18.00
ZNRE.DAY17	27.00,	ZNRE.DAY18	9.00,	ZNRE.DAY19	18.00,	ZNRE.DAY20	27.00
ZNRE.DAY21	27.00,	HTDS.DAY7	20.01,	HTDS.DAY8	10.75,	HTDS.DAY9	26.72
HTDS.DAY11	3.14,	HTDS.DAY12	59.80,	HTDS.DAY18	90.00,	HTDS.DAY21	60.00
FGDC.DAY6	43.25,	FGDC.DAY7	40.08,	FGDC.DAY8	32.24,	FGDC.DAY9	4.71
FGDC.DAY10	16.12,	FGDC.DAY12	90.00,	FGDC.DAY13	90.00,	FGDC.DAY14	90.00
FGDC.DAY15	90.00,	FGDC.DAY16	90.00,	FGDC.DAY17	90.00,	FGDC.DAY18	90.00
FGDC.DAY19	90.00,	FGDC.DAY20	90.00,	FGDC.DAY21	90.00		

---- 1357 VARIABLE ALLOT.L new aircraft assets made available
allotted to base (I).

C5 .TYFR.DAY1	1.44,	C5 .XDAT.DAY1	8.56
C5 .XDAT.DAY6	30.00,	C5 .XDAT.DAY11	40.00
C17 .TYFR.DAY1	2.00,	C17 .TYFR.DAY6	6.00
C17 .TYFR.DAY11	8.00,	C141.QFQE.DAY1	3.29
C141.QFQE.DAY6	6.17,	C141.TYFR.DAY1	5.02
C141.TYFR.DAY6	53.83,	C141.XDAT.DAY1	11.69
C141.XDAT.DAY11	80.00,	C130.TYFR.DAY1	20.00
C130.TYFR.DAY6	60.00,	C130.TYFR.DAY11	80.00
747P.TYFR.DAY6	6.51,	747P.TYFR.DAY11	30.00
747P.TYFR.DAY16	20.00,	747P.XDAT.DAY6	3.49
747C.QFQE.DAY6	2.68,	747C.TYFR.DAY6	1.19
747C.TYFR.DAY11	7.34,	747C.TYFR.DAY16	8.37
747C.XDAT.DAY6	1.13,	747C.XDAT.DAY11	17.66
747C.XDAT.DAY16	29.35,	DC10.TMKH.DAY11	7.10
DC10.TYFR.DAY11	17.90,	DC10.TYFR.DAY16	6.29
DC10.XDAT.DAY6	5.00,	DC10.XDAT.DAY16	9.67

---- 1359 VARIABLE X.L number of airlift missions (aircraft)

UNITA.C141.XDAT.FFTJ.QFQE.FFTJ.FFTJ.DAY12	11.22
UNITA.C141.XDAT.FFTJ.QFQE.FFTJ.FFTJ.DAY13	9.98
UNITA.C141.XDAT.FFTJ.QFQE.FFTJ.FFTJ.DAY14	8.48
UNITA.C141.XDAT.FFTJ.QFQE.FFTJ.FFTJ.DAY15	33.48
UNITA.C141.XDAT.FFTJ.QFQE.FFTJ.FFTJ.DAY16	3.51
UNITA.747P.XDAT.FFTJ.XDAT.ZNRE.FGDC.DAY12	3.87
UNITA.747P.XDAT.FFTJ.XDAT.ZNRE.FGDC.DAY16	10.80
UNITA.747P.XDAT.FFTJ.NNGX.TYFR.FFTJ.DAY16	25.98
UNITA.747C.XDAT.FFTJ.XDAT.ZNRE.FGDC.DAY19	10.80
UNITA.747C.XDAT.FFTJ.XDAT.ZNRE.FGDC.DAY20	21.60
UNITA.747C.XDAT.FFTJ.NNGX.TYFR.FFTJ.DAY13	21.53
UNITA.747C.XDAT.FFTJ.NNGX.TYFR.FFTJ.DAY14	8.47
UNITA.747C.XDAT.FFTJ.NNGX.TYFR.FFTJ.DAY15	15.75

UNITA.747C.XDAT.FFTJ.NNGX.TYFR.FFTJ.DAY16	23.93
UNITA.747C.XDAT.FFTJ.NNGX.TYFR.FFTJ.DAY17	4.29
UNITA.747C.XDAT.FFTJ.NNGX.HTDS.FFTJ.DAY17	22.73
UNITA.747C.XDAT.FFTJ.NNGX.HTDS.FFTJ.DAY20	21.60
UNITA.DC10.XDAT.FFTJ.NNGX.HTDS.FFTJ.DAY17	9.67
UNITB.C130.TYFR.FFTJ.TYFR.TYFR.FFTJ.DAY16	26.37
UNITB.747C.TYFR.FFTJ.TYFR.TYFR.FFTJ.DAY18	3.05
UNITB.DC10.TYFR.FFTJ.TYFR.TYFR.FFTJ.DAY17	2.35
UNITB.DC10.TYFR.FFTJ.TYFR.TYFR.FFTJ.DAY19	3.95
UNITC.C5.XDAT.FFTJ.QFQE.FFTJ.FFTJ.DAY11	40.00
UNITC.C141.XDAT.FFTJ.QFQE.FFTJ.FFTJ.DAY11	13.33
UNITC.747P.XDAT.FFTJ.NNGX.HTDS.FFTJ.DAY6	2.20
UNITC.747P.XDAT.FFTJ.NNGX.HTDS.FFTJ.DAY7	3.87
UNITC.747P.XDAT.FFTJ.NNGX.HTDS.FFTJ.DAY8	3.49
UNITC.747C.XDAT.FFTJ.NNGX.HTDS.FFTJ.DAY10	0.37
UNITC.747C.XDAT.FFTJ.NNGX.HTDS.FFTJ.DAY11	21.53
UNITC.DC10.XDAT.FFTJ.NNGX.HTDS.FFTJ.DAY6	5.00
UNITC.DC10.XDAT.FFTJ.NNGX.HTDS.FFTJ.DAY8	5.00
UNITD.C5.TMKH.FFTJ.QFQE.FFTJ.FFTJ.DAY21	22.56
UNITD.C5.TMKH.FFTJ.QFQE.FFTJ.FFTJ.DAY22	2.31
UNITD.C5.TMKH.FFTJ.QFQE.FFTJ.FFTJ.DAY24	48.00
UNITD.C5.TMKH.FFTJ.QFQE.FFTJ.FFTJ.DAY25	32.00
UNITD.C5.TMKH.FFTJ.QFQE.FFTJ.FFTJ.DAY27	39.11
UNITD.C5.TMKH.FFTJ.TYFR.FFTJ.FFTJ.DAY22	23.13
UNITD.C17.TMKH.FFTJ.QFQE.FFTJ.FFTJ.DAY26	16.00
UNITD.C17.TMKH.FFTJ.TYFR.FFTJ.FFTJ.DAY22	16.00
UNITD.C141.TMKH.FFTJ.QFQE.FFTJ.FFTJ.DAY23	30.02
UNITD.C141.TMKH.FFTJ.TYFR.FFTJ.FFTJ.DAY24	37.33
UNITD.C141.TMKH.FFTJ.TYFR.FFTJ.FFTJ.DAY25	17.08
UNITD.C141.TMKH.FFTJ.TYFR.FFTJ.FFTJ.DAY26	100.00
UNITD.C130.TMKH.FFTJ.QFQE.FFTJ.FFTJ.DAY22	3.93
UNITD.C130.TMKH.FFTJ.QFQE.FFTJ.FFTJ.DAY27	93.12
UNITD.C130.TMKH.FFTJ.TYFR.FFTJ.FFTJ.DAY21	31.98
UNITD.747C.TMKH.FFTJ.TMKH.TYFR.FFTJ.DAY22	23.63
UNITD.747C.TMKH.FFTJ.TMKH.TYFR.FFTJ.DAY26	6.51
UNITE.C17.TYFR.UGZX.TYFR.TYFR.UGZX.DAY11	8.00
UNITE.C130.TYFR.UGZX.TYFR.TYFR.UGZX.DAY12	53.63
UNITE.747P.TYFR.UGZX.TYFR.TYFR.UGZX.DAY11	14.43
UNITE.747P.TYFR.UGZX.TYFR.TYFR.UGZX.DAY13	15.57
UNITE.747P.TYFR.UGZX.TYFR.TYFR.UGZX.DAY16	20.00
UNITE.747C.TYFR.UGZX.TYFR.TYFR.UGZX.DAY11	7.34
UNITE.747C.TYFR.UGZX.TYFR.TYFR.UGZX.DAY16	5.32
UNITE.DC10.TYFR.UGZX.TYFR.TYFR.UGZX.DAY11	17.90
UNITF.C5.TMKH.UGZX.QFQE.UGZX.UGZX.DAY11	37.32
UNITF.C5.TMKH.UGZX.QFQE.UGZX.UGZX.DAY12	0.60
UNITF.C5.TMKH.UGZX.QFQE.UGZX.UGZX.DAY13	37.32
UNITF.C5.TMKH.UGZX.QFQE.UGZX.UGZX.DAY14	37.32
UNITF.C5.TMKH.UGZX.QFQE.UGZX.UGZX.DAY15	13.94
UNITF.C5.TMKH.UGZX.QFQE.UGZX.UGZX.DAY16	29.40
UNITF.C5.TMKH.UGZX.QFQE.UGZX.UGZX.DAY17	37.32
UNITF.C5.TMKH.UGZX.QFQE.UGZX.UGZX.DAY18	37.32
UNITF.C5.TMKH.UGZX.QFQE.UGZX.UGZX.DAY19	37.32
UNITF.C5.TMKH.UGZX.TYFR.UGZX.UGZX.DAY20	25.44
UNITF.C5.TMKH.UGZX.TYFR.UGZX.UGZX.DAY21	32.00
UNITF.C17.TMKH.UGZX.QFQE.UGZX.UGZX.DAY11	0.79
UNITF.C17.TMKH.UGZX.QFQE.UGZX.UGZX.DAY15	8.00
UNITF.C17.TMKH.UGZX.QFQE.UGZX.UGZX.DAY17	7.71
UNITF.C17.TMKH.UGZX.QFQE.UGZX.UGZX.DAY19	8.00
UNITF.C17.TMKH.UGZX.QFQE.UGZX.UGZX.DAY20	8.00
UNITF.C17.TMKH.UGZX.TYFR.UGZX.UGZX.DAY11	7.21

UNITF.C17	.TMKH.UGZX.TYFR.UGZX.UGZX.DAY12	8.00
UNITF.C17	.TMKH.UGZX.TYFR.UGZX.UGZX.DAY13	8.00
UNITF.C17	.TMKH.UGZX.TYFR.UGZX.UGZX.DAY14	8.00
UNITF.C17	.TMKH.UGZX.TYFR.UGZX.UGZX.DAY16	8.00
UNITF.C17	.TMKH.UGZX.TYFR.UGZX.UGZX.DAY17	0.29
UNITF.C17	.TMKH.UGZX.TYFR.UGZX.UGZX.DAY18	8.00
UNITF.C141	.TMKH.UGZX.TYFR.UGZX.UGZX.DAY21	18.96
UNITF.C130	.TMKH.UGZX.TYFR.UGZX.UGZX.DAY20	57.21
UNITF.747P	.TMKH.UGZX.TMCH.TYFR.UGZX.DAY12	3.68
UNITF.747C	.TMKH.UGZX.TMCH.TYFR.UGZX.DAY12	8.47
UNITF.747C	.TMKH.UGZX.TMCH.TYFR.UGZX.DAY16	8.58
UNITG.C5	.TYFR.UGZX.TYFR.TYFR.UGZX.DAY1	1.44
UNITG.C17	.TYFR.UGZX.TYFR.TYFR.UGZX.DAY1	2.00
UNITG.C141	.TYFR.UGZX.TYFR.TYFR.UGZX.DAY2	1.73
UNITG.C130	.TYFR.UGZX.TYFR.TYFR.UGZX.DAY1	20.00
UNITH.C5	.XDAT.UGZX.QFQE.UGZX.UGZX.DAY1	8.56
UNITH.C5	.XDAT.UGZX.QFQE.UGZX.UGZX.DAY6	14.28
UNITH.C141	.XDAT.UGZX.QFQE.UGZX.UGZX.DAY2	1.72
UNITH.C141	.XDAT.UGZX.QFQE.UGZX.UGZX.DAY3	2.22
UNITI.C141	.QFQE.UGZX.TYFR.UGZX.UGZX.DAY2	3.29
UNITI.C141	.QFQE.UGZX.TYFR.UGZX.UGZX.DAY6	6.17
UNITI.747C	.QFQE.UGZX.TYFR.UGZX.UGZX.DAY6	2.68
UNITJ.C5	.XDAT.UGZX.QFQE.UGZX.UGZX.DAY6	8.82
UNITJ.C141	.XDAT.UGZX.QFQE.UGZX.UGZX.DAY2	7.75
UNITJ.747P	.XDAT.UGZX.NNGX.TYFR.UGZX.DAY6	1.28
UNITJ.747C	.XDAT.UGZX.NNGX.TYFR.UGZX.DAY6	1.13
UNITJ.747C	.XDAT.UGZX.NNGX.TYFR.UGZX.DAY7	2.70
UNITJ.747C	.XDAT.UGZX.NNGX.HTDS.UGZX.DAY8	1.13
UNITK.C141	.TYFR.UGZX.TYFR.TYFR.UGZX.DAY2	3.29
UNITK.C141	.TYFR.UGZX.TYFR.TYFR.UGZX.DAY6	16.07
UNITL.C141	.TYFR.UGZX.TYFR.TYFR.UGZX.DAY6	11.31
UNITL.747P	.TYFR.UGZX.TYFR.TYFR.UGZX.DAY6	1.48
UNITL.747C	.TYFR.UGZX.TYFR.TYFR.UGZX.DAY6	1.19
UNITM.C141	.TYFR.UGZX.TYFR.TYFR.UGZX.DAY6	10.37
UNITM.C130	.TYFR.UGZX.TYFR.TYFR.UGZX.DAY6	13.12
UNITM.747P	.TYFR.UGZX.TYFR.TYFR.UGZX.DAY6	1.16
UNITN.C141	.TYFR.UGZX.TYFR.TYFR.UGZX.DAY6	16.07
UNITN.747P	.TYFR.UGZX.TYFR.TYFR.UGZX.DAY6	1.22
UNITO.C17	.TYFR.PKVV.TYFR.TYFR.PKVV.DAY6	6.00
UNITO.C130	.TYFR.PKVV.TYFR.TYFR.PKVV.DAY6	12.24
UNITO.747P	.TYFR.PKVV.TYFR.TYFR.PKVV.DAY6	1.48
UNITP.C130	.TYFR.PKVV.TYFR.TYFR.PKVV.DAY6	34.65
UNITP.747P	.TYFR.PKVV.TYFR.TYFR.PKVV.DAY6	1.16
UNITQ.C5	.TMKH.PKVV.QFQE.UGZX.UGZX.DAY4	2.08
UNITQ.C17	.TMKH.PKVV.QFQE.UGZX.UGZX.DAY4	2.00
UNITQ.C17	.TMKH.PKVV.QFQE.UGZX.UGZX.DAY6	2.00
UNITQ.C17	.TMKH.PKVV.QFQE.UGZX.UGZX.DAY7	1.05
UNITQ.C141	.TMKH.PKVV.QFQE.UGZX.UGZX.DAY4	17.77
UNITQ.C141	.TMKH.PKVV.QFQE.UGZX.UGZX.DAY5	2.22
UNITQ.C141	.TMKH.PKVV.QFQE.UGZX.UGZX.DAY6	3.36
UNITQ.C130	.TMKH.PKVV.QFQE.UGZX.UGZX.DAY4	20.00
UNITR.C5	.TMKH.UGZX.QFQE.UGZX.UGZX.DAY4	7.92
UNITR.C5	.TMKH.UGZX.TYFR.UGZX.UGZX.DAY6	5.11
UNITR.C141	.TMKH.UGZX.TYFR.UGZX.UGZX.DAY6	11.25
UNITS.C5	.TMKH.UGZX.QFQE.UGZX.UGZX.DAY7	4.89
UNITS.C17	.TMKH.UGZX.QFQE.UGZX.UGZX.DAY7	4.95
UNITS.C141	.TMKH.UGZX.TYFR.UGZX.UGZX.DAY7	31.06
UNITT.C5	.XDAT.UGZX.QFQE.UGZX.UGZX.DAY7	6.89
UNITT.747P	.XDAT.UGZX.NNGX.TYFR.UGZX.DAY7	2.64
UNITT.747C	.XDAT.UGZX.NNGX.TYFR.UGZX.DAY7	1.17

UNITT.747C.XDAT.UGZX.NNGX.TYFR.UGZX.DAY9 3.87
 UNITT.747C.XDAT.UGZX.NNGX.HTDS.UGZX.DAY10 0.76

---	1361 VARIABLE Y.L	number of type A aircraft recovered
C5	.TMKH.FFTJ.QFQE.FFTJ.FFTJ.DAY26	39.11
C5	.TMKH.FFTJ.TYFR.FFTJ.FFTJ.DAY12	34.64
C5	.TMKH.FFTJ.WWYK.FFTJ.FFTJ.DAY18	5.36
C5	.TMKH.FFTJ.WWYK.FFTJ.FFTJ.DAY23	48.00
C5	.TMKH.UGZX.QFQE.UGZX.UGZX.DAY3	10.00
C5	.TMKH.UGZX.QFQE.UGZX.UGZX.DAY9	37.92
C5	.TMKH.UGZX.QFQE.UGZX.UGZX.DAY15	24.90
C5	.TMKH.UGZX.QFQE.UGZX.UGZX.DAY21	25.44
C5	.TMKH.UGZX.QFQE.UGZX.UGZX.DAY23	9.22
C5	.TMKH.UGZX.TYFR.UGZX.UGZX.DAY5	3.03
C5	.TMKH.UGZX.TYFR.UGZX.UGZX.DAY6	4.89
C5	.TMKH.UGZX.TYFR.UGZX.UGZX.DAY12	2.68
C5	.TMKH.UGZX.TYFR.UGZX.UGZX.DAY15	4.50
C5	.TMKH.UGZX.TYFR.UGZX.UGZX.DAY20	5.15
C5	.TMKH.UGZX.TYFR.UGZX.UGZX.DAY23	22.78
C5	.TMKH.UGZX.WWYK.UGZX.UGZX.DAY13	37.32
C5	.TMKH.UGZX.WWYK.UGZX.UGZX.DAY14	13.94
C5	.TMKH.UGZX.WWYK.UGZX.UGZX.DAY16	45.24
C5	.TMKH.UGZX.WWYK.UGZX.UGZX.DAY17	29.40
C5	.TMKH.UGZX.WWYK.UGZX.UGZX.DAY18	37.32
C5	.TMKH.UGZX.WWYK.UGZX.UGZX.DAY19	20.08
C5	.TMKH.UGZX.WWYK.UGZX.UGZX.DAY20	49.41
C5	.TMKH.PKVV.TYFR.UGZX.PKVV.DAY5	2.08
C17	.TMKH.FFTJ.WWYK.FFTJ.FFTJ.DAY24	16.00
C17	.TMKH.UGZX.QFQE.UGZX.UGZX.DAY3	2.00
C17	.TMKH.UGZX.QFQE.UGZX.UGZX.DAY8	4.95
C17	.TMKH.UGZX.QFQE.UGZX.UGZX.DAY13	8.00
C17	.TMKH.UGZX.QFQE.UGZX.UGZX.DAY17	8.00
C17	.TMKH.UGZX.TYFR.UGZX.UGZX.DAY11	8.00
C17	.TMKH.UGZX.TYFR.UGZX.UGZX.DAY14	8.00
C17	.TMKH.UGZX.TYFR.UGZX.UGZX.DAY15	8.00
C17	.TMKH.UGZX.TYFR.UGZX.UGZX.DAY16	8.00
C17	.TMKH.UGZX.TYFR.UGZX.UGZX.DAY18	8.00
C17	.TMKH.UGZX.TYFR.UGZX.UGZX.DAY19	8.00
C17	.TMKH.UGZX.WWYK.UGZX.UGZX.DAY12	8.00
C17	.TMKH.UGZX.WWYK.UGZX.UGZX.DAY21	16.00
C17	.TMKH.PKVV.QFQE.UGZX.PKVV.DAY5	2.00
C17	.TMKH.PKVV.QFQE.UGZX.PKVV.DAY8	3.05
C17	.TMKH.PKVV.TYFR.UGZX.PKVV.DAY6	6.00
C141	.TMKH.FFTJ.TYFR.FFTJ.FFTJ.DAY23	27.18
C141	.TMKH.FFTJ.TYFR.FFTJ.FFTJ.DAY27	54.42
C141	.TMKH.FFTJ.WWYK.FFTJ.FFTJ.DAY20	52.82
C141	.TMKH.FFTJ.WWYK.FFTJ.FFTJ.DAY24	30.02
C141	.TMKH.UGZX.QFQE.UGZX.UGZX.DAY3	17.77
C141	.TMKH.UGZX.QFQE.UGZX.UGZX.DAY4	2.22
C141	.TMKH.UGZX.QFQE.UGZX.UGZX.DAY6	27.89
C141	.TMKH.UGZX.QFQE.UGZX.UGZX.DAY20	41.25
C141	.TMKH.UGZX.QFQE.UGZX.UGZX.DAY22	27.24
C141	.TMKH.UGZX.TYFR.UGZX.UGZX.DAY20	24.89
C141	.TMKH.PKVV.QFQE.UGZX.PKVV.DAY5	17.77
C141	.TMKH.PKVV.QFQE.UGZX.PKVV.DAY26	5.58
C130	.TMKH.FFTJ.QFQE.FFTJ.FFTJ.DAY18	22.45
C130	.TMKH.FFTJ.TYFR.FFTJ.FFTJ.DAY24	35.91
C130	.TMKH.FFTJ.WWYK.FFTJ.FFTJ.DAY20	3.93
C130	.TMKH.UGZX.QFQE.UGZX.UGZX.DAY3	20.00
C130	.TMKH.UGZX.TYFR.UGZX.UGZX.DAY7	13.12

C130.TMKH.UGZX.TYFR.UGZX.UGZX.DAY23	57.21
C130.TMKH.UGZX.WWYK.UGZX.UGZX.DAY17	53.63
C130.TMKH.PKVV.QFQE.UGZX.PKVV.DAY28	66.88
747P.TMKH.FFTJ.QFQE.FFTJ.FFTJ.DAY11	3.41
747P.TMKH.FFTJ.TYFR.FFTJ.FFTJ.DAY21	36.78
747P.TMKH.UGZX.QFQE.UGZX.UGZX.DAY20	23.22
747P.TMKH.UGZX.TYFR.UGZX.UGZX.DAY11	0.26
747P.XDAT.FFTJ.FXSB.ZNRE.FGDC.DAY7	2.50
747P.XDAT.FFTJ.FXSB.ZNRE.FGDC.DAY8	3.57
747P.XDAT.FFTJ.UTKY.ZNRE.FGDC.DAY12	0.07
747P.XDAT.FFTJ.UTKY.ZNRE.FGDC.DAY13	3.87
747P.XDAT.UGZX.UTKY.ZNRE.FGDC.DAY6	3.87
747P.XDAT.UGZX.UTKY.ZNRE.FGDC.DAY7	1.28
747P.XDAT.UGZX.UTKY.ZNRE.FGDC.DAY13	5.39
747P.XDAT.UGZX.UTKY.ZNRE.FGDC.DAY14	5.85
747P.XDAT.UGZX.UTKY.ZNRE.FGDC.DAY15	21.60
747P.XDAT.PKVV.KNMD.ZNRE.FGDC.DAY6	2.64
747C.TMKH.FFTJ.QFQE.FFTJ.FFTJ.DAY14	5.78
747C.TMKH.FFTJ.QFQE.FFTJ.FFTJ.DAY23	23.63
747C.TMKH.FFTJ.QFQE.FFTJ.FFTJ.DAY27	6.51
747C.TMKH.FFTJ.TYFR.FFTJ.FFTJ.DAY11	0.37
747C.TMKH.FFTJ.TYFR.FFTJ.FFTJ.DAY15	2.80
747C.TMKH.FFTJ.NNGX.FFTJ.FFTJ.DAY21	43.20
747C.TMKH.UGZX.QFQE.UGZX.UGZX.DAY11	8.10
747C.TMKH.UGZX.TYFR.UGZX.UGZX.DAY16	5.14
747C.TMKH.UGZX.TYFR.UGZX.UGZX.DAY17	8.58
747C.XDAT.FFTJ.KNMD.ZNRE.FGDC.DAY17	10.80
747C.XDAT.FFTJ.KNMD.ZNRE.FGDC.DAY18	21.60
747C.XDAT.FFTJ.UTKY.ZNRE.FGDC.DAY12	21.53
747C.XDAT.FFTJ.UTKY.ZNRE.FGDC.DAY14	15.75
747C.XDAT.FFTJ.UTKY.ZNRE.FGDC.DAY16	21.42
747C.XDAT.FFTJ.UTKY.ZNRE.FGDC.DAY19	21.60
747C.XDAT.FFTJ.UTKY.ZNRE.FGDC.DAY20	10.80
747C.XDAT.UGZX.FXSB.ZNRE.FGDC.DAY6	3.87
747C.XDAT.UGZX.FXSB.ZNRE.FGDC.DAY8	3.87
747C.XDAT.UGZX.FXSB.ZNRE.FGDC.DAY10	3.87
747C.XDAT.UGZX.UTKY.ZNRE.FGDC.DAY7	1.13
747C.XDAT.UGZX.UTKY.ZNRE.FGDC.DAY9	1.13
747C.XDAT.UGZX.UTKY.ZNRE.FGDC.DAY13	8.47
747C.XDAT.UGZX.UTKY.ZNRE.FGDC.DAY16	0.18
DC10.TMKH.FFTJ.QFQE.FFTJ.FFTJ.DAY18	12.01
DC10.TMKH.FFTJ.TYFR.FFTJ.FFTJ.DAY12	5.00
DC10.TMKH.FFTJ.WWYK.FFTJ.FFTJ.DAY19	3.95
DC10.TMKH.UGZX.TYFR.UGZX.UGZX.DAY12	17.90
DC10.XDAT.FFTJ.FXSB.ZNRE.FGDC.DAY7	5.00

---- 1363 VARIABLE TONSUE.L unit U's equipment (in 100 tons)
airlifted

UNITA.C141.XDAT.FFTJ.QFQE.FFTJ.FFTJ.DAY12	1.26
UNITA.C141.XDAT.FFTJ.QFQE.FFTJ.FFTJ.DAY13	1.12
UNITA.C141.XDAT.FFTJ.QFQE.FFTJ.FFTJ.DAY14	0.95
UNITA.C141.XDAT.FFTJ.QFQE.FFTJ.FFTJ.DAY15	3.76
UNITA.C141.XDAT.FFTJ.QFQE.FFTJ.FFTJ.DAY16	0.39
UNITA.747C.XDAT.FFTJ.NNGX.TYFR.FFTJ.DAY13	22.10
UNITA.747C.XDAT.FFTJ.NNGX.TYFR.FFTJ.DAY14	8.70
UNITA.747C.XDAT.FFTJ.NNGX.TYFR.FFTJ.DAY15	16.17
UNITA.747C.XDAT.FFTJ.NNGX.TYFR.FFTJ.DAY16	24.56
UNITB.C130.TYFR.FFTJ.TYFR.TYFR.FFTJ.DAY16	3.67
UNITB.747C.TYFR.FFTJ.TYFR.TYFR.FFTJ.DAY18	3.25

UNITC.C5	.XDAT.FFTJ.QFQE.FFTJ.FFTJ.DAY11	19.93
UNITC.C141	.XDAT.FFTJ.QFQE.FFTJ.FFTJ.DAY11	1.50
UNITC.747C	.XDAT.FFTJ.NNGX.HTDS.FFTJ.DAY10	0.35
UNITC.747C	.XDAT.FFTJ.NNGX.HTDS.FFTJ.DAY11	20.58
UNITD.C5	.TMKH.FFTJ.QFQE.FFTJ.FFTJ.DAY21	15.41
UNITD.C5	.TMKH.FFTJ.QFQE.FFTJ.FFTJ.DAY24	32.79
UNITD.C5	.TMKH.FFTJ.QFQE.FFTJ.FFTJ.DAY25	21.86
UNITD.C5	.TMKH.FFTJ.TYFR.FFTJ.FFTJ.DAY22	15.80
UNITD.C17	.TMKH.FFTJ.TYFR.FFTJ.FFTJ.DAY22	4.51
UNITD.C130	.TMKH.FFTJ.QFQE.FFTJ.FFTJ.DAY22	0.47
UNITD.C130	.TMKH.FFTJ.TYFR.FFTJ.FFTJ.DAY21	2.25
UNITD.747C	.TMKH.FFTJ.TMKH.TYFR.FFTJ.DAY22	21.84
UNITE.C17	.TYFR.UGZX.TYFR.TYFR.UGZX.DAY11	4.27
UNITE.C130	.TYFR.UGZX.TYFR.TYFR.UGZX.DAY12	8.43
UNITE.747C	.TYFR.UGZX.TYFR.TYFR.UGZX.DAY11	8.85
UNITE.747C	.TYFR.UGZX.TYFR.TYFR.UGZX.DAY16	6.42
UNITF.C5	.TMKH.UGZX.QFQE.UGZX.UGZX.DAY11	23.61
UNITF.C5	.TMKH.UGZX.QFQE.UGZX.UGZX.DAY12	0.38
UNITF.C5	.TMKH.UGZX.QFQE.UGZX.UGZX.DAY13	23.61
UNITF.C5	.TMKH.UGZX.QFQE.UGZX.UGZX.DAY14	23.61
UNITF.C5	.TMKH.UGZX.QFQE.UGZX.UGZX.DAY15	8.82
UNITF.C5	.TMKH.UGZX.QFQE.UGZX.UGZX.DAY16	18.60
UNITF.C5	.TMKH.UGZX.QFQE.UGZX.UGZX.DAY17	23.61
UNITF.C5	.TMKH.UGZX.QFQE.UGZX.UGZX.DAY18	23.61
UNITF.C5	.TMKH.UGZX.QFQE.UGZX.UGZX.DAY19	24.68
UNITF.C5	.TMKH.UGZX.TYFR.UGZX.UGZX.DAY20	16.82
UNITF.C17	.TMKH.UGZX.QFQE.UGZX.UGZX.DAY11	0.31
UNITF.C17	.TMKH.UGZX.QFQE.UGZX.UGZX.DAY15	3.16
UNITF.C17	.TMKH.UGZX.QFQE.UGZX.UGZX.DAY17	3.05
UNITF.C17	.TMKH.UGZX.QFQE.UGZX.UGZX.DAY19	3.16
UNITF.C17	.TMKH.UGZX.QFQE.UGZX.UGZX.DAY20	3.16
UNITF.C17	.TMKH.UGZX.TYFR.UGZX.UGZX.DAY11	2.49
UNITF.C17	.TMKH.UGZX.TYFR.UGZX.UGZX.DAY12	2.76
UNITF.C17	.TMKH.UGZX.TYFR.UGZX.UGZX.DAY13	2.76
UNITF.C17	.TMKH.UGZX.TYFR.UGZX.UGZX.DAY14	2.76
UNITF.C17	.TMKH.UGZX.TYFR.UGZX.UGZX.DAY16	2.76
UNITF.C17	.TMKH.UGZX.TYFR.UGZX.UGZX.DAY17	0.08
UNITF.C17	.TMKH.UGZX.TYFR.UGZX.UGZX.DAY18	2.76
UNITF.C130	.TMKH.UGZX.TYFR.UGZX.UGZX.DAY20	6.48
UNITF.747C	.TMKH.UGZX.TMKH.TYFR.UGZX.DAY12	7.58
UNITF.747C	.TMKH.UGZX.TMKH.TYFR.UGZX.DAY16	7.67
UNITG.C5	.TYFR.UGZX.TYFR.TYFR.UGZX.DAY1	1.23
UNITG.C17	.TYFR.UGZX.TYFR.TYFR.UGZX.DAY1	1.02
UNITG.C130	.TYFR.UGZX.TYFR.TYFR.UGZX.DAY1	2.78
UNITH.C5	.XDAT.UGZX.QFQE.UGZX.UGZX.DAY1	3.01
UNITH.C5	.XDAT.UGZX.QFQE.UGZX.UGZX.DAY6	7.12
UNITI.C141	.QFQE.UGZX.TYFR.UGZX.UGZX.DAY6	1.93
UNITI.747C	.QFQE.UGZX.TYFR.UGZX.UGZX.DAY6	3.10
UNITJ.C5	.XDAT.UGZX.QFQE.UGZX.UGZX.DAY6	4.39
UNITJ.747C	.XDAT.UGZX.NNGX.TYFR.UGZX.DAY6	1.31
UNITJ.747C	.XDAT.UGZX.NNGX.TYFR.UGZX.DAY7	3.12
UNITJ.747C	.XDAT.UGZX.NNGX.HTDS.UGZX.DAY8	1.31
UNITK.C141	.TYFR.UGZX.TYFR.TYFR.UGZX.DAY6	5.03
UNITL.C141	.TYFR.UGZX.TYFR.TYFR.UGZX.DAY6	3.54
UNITL.747C	.TYFR.UGZX.TYFR.TYFR.UGZX.DAY6	1.37
UNITM.C141	.TYFR.UGZX.TYFR.TYFR.UGZX.DAY6	3.24
UNITM.C130	.TYFR.UGZX.TYFR.TYFR.UGZX.DAY6	1.98
UNITN.C141	.TYFR.UGZX.TYFR.TYFR.UGZX.DAY6	5.03
UNITO.C17	.TYFR.PKVV.TYFR.TYFR.PKVV.DAY6	3.07
UNITO.C130	.TYFR.PKVV.TYFR.TYFR.PKVV.DAY6	1.84

UNITP.C130.TYFR.PKV.V.TYFR.TYFR.PKV.V.DAY6	5.22
UNITQ.C5.TMKH.PKV.V.QFQE.UGZX.UGZX.DAY4	1.62
UNITQ.C17.TMKH.PKV.V.QFQE.UGZX.UGZX.DAY4	1.02
UNITQ.C17.TMKH.PKV.V.QFQE.UGZX.UGZX.DAY6	1.02
UNITQ.C17.TMKH.PKV.V.QFQE.UGZX.UGZX.DAY7	0.54
UNITQ.C141.TMKH.PKV.V.QFQE.UGZX.UGZX.DAY4	3.29
UNITQ.C130.TMKH.PKV.V.QFQE.UGZX.UGZX.DAY4	2.64
UNITR.C5.TMKH.UGZX.QFQE.UGZX.UGZX.DAY4	6.16
UNITR.C5.TMKH.UGZX.TYFR.UGZX.UGZX.DAY6	3.58
UNITR.C141.TMKH.UGZX.TYFR.UGZX.UGZX.DAY6	0.38
UNITS.C5.TMKH.UGZX.QFQE.UGZX.UGZX.DAY7	3.81
UNITS.C17.TMKH.UGZX.QFQE.UGZX.UGZX.DAY7	1.75
UNITS.C141.TMKH.UGZX.TYFR.UGZX.UGZX.DAY7	4.57
UNITT.C5.XDAT.UGZX.QFQE.UGZX.UGZX.DAY7	3.43
UNITT.747C.XDAT.UGZX.NNGX.TYFR.UGZX.DAY7	1.35
UNITT.747C.XDAT.UGZX.NNGX.TYFR.UGZX.DAY9	4.47
UNITT.747C.XDAT.UGZX.NNGX.HTDS.UGZX.DAY10	0.88

---- 1365 VARIABLE TPAX.L number (in 100s) of unit U's troops
airlifted

UNITA.747P.XDAT.FFTJ.XDAT.ZNRE.FGDC.DAY12	11.56
UNITA.747P.XDAT.FFTJ.XDAT.ZNRE.FGDC.DAY16	32.27
UNITA.747P.XDAT.FFTJ.NNGX.TYFR.FFTJ.DAY16	83.15
UNITB.DC10.TYFR.FFTJ.TYFR.TYFR.FFTJ.DAY17	5.16
UNITB.DC10.TYFR.FFTJ.TYFR.TYFR.FFTJ.DAY19	8.68
UNITC.747P.XDAT.FFTJ.NNGX.HTDS.FFTJ.DAY6	7.05
UNITC.747P.XDAT.FFTJ.NNGX.HTDS.FFTJ.DAY7	12.38
UNITC.747P.XDAT.FFTJ.NNGX.HTDS.FFTJ.DAY8	11.16
UNITC.DC10.XDAT.FFTJ.NNGX.HTDS.FFTJ.DAY6	11.00
UNITC.DC10.XDAT.FFTJ.NNGX.HTDS.FFTJ.DAY8	11.00
UNITD.C17.TMKH.FFTJ.TYFR.FFTJ.FFTJ.DAY22	8.64
UNITD.C141.TMKH.FFTJ.QFQE.FFTJ.FFTJ.DAY23	32.03
UNITD.C141.TMKH.FFTJ.TYFR.FFTJ.FFTJ.DAY24	34.44
UNITD.C141.TMKH.FFTJ.TYFR.FFTJ.FFTJ.DAY25	15.76
UNITD.C130.TMKH.FFTJ.TYFR.FFTJ.FFTJ.DAY21	6.89
UNITE.747P.TYFR.UGZX.TYFR.TYFR.UGZX.DAY11	46.18
UNITE.747P.TYFR.UGZX.TYFR.TYFR.UGZX.DAY13	49.82
UNITE.747P.TYFR.UGZX.TYFR.TYFR.UGZX.DAY16	64.00
UNITE.DC10.TYFR.UGZX.TYFR.TYFR.UGZX.DAY11	39.37
UNITF.C5.TMKH.UGZX.QFQE.UGZX.UGZX.DAY11	27.24
UNITF.C5.TMKH.UGZX.QFQE.UGZX.UGZX.DAY12	0.44
UNITF.C5.TMKH.UGZX.QFQE.UGZX.UGZX.DAY13	27.24
UNITF.C5.TMKH.UGZX.QFQE.UGZX.UGZX.DAY14	27.24
UNITF.C5.TMKH.UGZX.QFQE.UGZX.UGZX.DAY15	10.18
UNITF.C5.TMKH.UGZX.QFQE.UGZX.UGZX.DAY16	21.46
UNITF.C5.TMKH.UGZX.QFQE.UGZX.UGZX.DAY17	27.24
UNITF.C5.TMKH.UGZX.QFQE.UGZX.UGZX.DAY18	27.24
UNITF.C17.TMKH.UGZX.TYFR.UGZX.UGZX.DAY11	1.62
UNITF.C17.TMKH.UGZX.TYFR.UGZX.UGZX.DAY12	1.80
UNITF.C17.TMKH.UGZX.TYFR.UGZX.UGZX.DAY13	1.80
UNITF.C17.TMKH.UGZX.TYFR.UGZX.UGZX.DAY14	1.80
UNITF.C17.TMKH.UGZX.TYFR.UGZX.UGZX.DAY16	1.80
UNITF.C17.TMKH.UGZX.TYFR.UGZX.UGZX.DAY17	0.16
UNITF.C17.TMKH.UGZX.TYFR.UGZX.UGZX.DAY18	1.80
UNITG.747P.TMKH.UGZX.TMKH.TYFR.UGZX.DAY12	11.76
UNITG.C5.TYFR.UGZX.TYFR.TYFR.UGZX.DAY1	1.05
UNITG.C141.TYFR.UGZX.TYFR.TYFR.UGZX.DAY2	2.06
UNITG.C130.TYFR.UGZX.TYFR.TYFR.UGZX.DAY1	0.81
UNITH.C5.XDAT.UGZX.QFQE.UGZX.UGZX.DAY1	6.25

UNITH.C141.XDAT.UGZX.QFQE.UGZX.UGZX.DAY2	0.96
UNITH.C141.XDAT.UGZX.QFQE.UGZX.UGZX.DAY3	1.25
UNITI.C141.QFQE.UGZX.TYFR.UGZX.UGZX.DAY2	3.92
UNITJ.C141.XDAT.UGZX.QFQE.UGZX.UGZX.DAY2	4.35
UNITJ.747P.XDAT.UGZX.NNGX.TYFR.UGZX.DAY6	4.11
UNITK.C141.TYFR.UGZX.TYFR.TYFR.UGZX.DAY2	3.92
UNITL.747P.TYFR.UGZX.TYFR.TYFR.UGZX.DAY6	4.74
UNITM.747P.TYFR.UGZX.TYFR.TYFR.UGZX.DAY6	3.72
UNITN.747P.TYFR.UGZX.TYFR.TYFR.UGZX.DAY6	3.92
UNITO.747P.TYFR.PKVV.TYFR.TYFR.PKVV.DAY6	4.74
UNITP.747P.TYFR.PKVV.TYFR.TYFR.PKVV.DAY6	3.72
UNITQ.C141.TMKH.PKVV.QFQE.UGZX.UGZX.DAY4	2.50
UNITQ.C141.TMKH.PKVV.QFQE.UGZX.UGZX.DAY5	2.37
UNITQ.C141.TMKH.PKVV.QFQE.UGZX.UGZX.DAY6	3.58
UNITR.C141.TMKH.UGZX.TYFR.UGZX.UGZX.DAY6	8.46
UNITS.C17.TMKH.UGZX.QFQE.UGZX.UGZX.DAY7	2.67
UNITS.C141.TMKH.UGZX.TYFR.UGZX.UGZX.DAY7	5.79
UNITT.747P.XDAT.UGZX.NNGX.TYFR.UGZX.DAY7	8.46

EXECUTION TIME = 31.990 SECONDS

VERID AIX-00-064

USER: Operations Research Department
Naval Postgraduate School

G940405-1442AX-AIX

**** FILE SUMMARY

RESTART /home/limt/final.g0?
INPUT /home/limt/alrep.gms
OUTPUT /home/limt/alrep.lst

STEP SUMMARY: 0.260 STARTUP
0.060 COMPILATION
31.990 EXECUTION
0.000 CLOSEDOWN
32.310 TOTAL SECONDS

LIST OF REFERENCES

1. Joint Staff(J8), Force Design Division, The Pentagon, Washington, DC, *Determining the Optimal Mobility Mix*, by Wing, V.F., Rice, R.E., Sherwood, R.W. and Rosenthal, R.E., 1 October 1991.
2. Yost, K.A., "The Thruput Strategic Airlift Flow Optimization Model," 30 June 1994.
3. Brooke, A., Kendrick, D., and Meeraus, A., *GAMS A User's Guide*, The Scientific Press, 1992.
4. Killingsworth, P., and Melody, L., "CONOP Air Mobility Optimization Model," paper presented at the Mobility Optimization Meeting, Monterey, California, 6 July 1994.

INITIAL DISTRIBUTION LIST

	No. Copies
1. Defense Technical Information Center Cameron Station Alexandria, Virginia 22304-6145	2
2. Library, Code 52 Naval Postgraduate School Monterey, California 93943-5101	2
3. Chief Defense Scientist MINDEF Building Gombak Drive, Singapore 2366 Republic of Singapore	1
4. Professor Richard E. Rosenthal, Code OR/RI Naval Postgraduate School Monterey, CA 93943-5000	5
5. Dr. David P. Morton, Code OR/MO Naval Postgraduate School Monterey, CA 93943-5000	2
6. Professor Gerald G. Brown, Code OR/BW Naval Postgraduate School Monterey, CA 93943-500	1
7. USAF Studies & Analyses Agency (Attn: CPT David Horton) 1570 Airforcc Pentagon Washington, DC 20330-1570	3
8. MAJ Kirk Yost OAS/XRC 3550 Aberdeen Ave Kirtland AFB, NM 87117-5776	1

9. CDR Vern Wing 1
354 B Ave
Coronado, CA 92118

10. Paul Killingsworth 1
RAND
1700 Main St
Santa Monica, CA 90407-2138

11. Alan Whisman 1
Air Mobility Command
SAF, Room 3L3
402 Scott Dr
Scott AFB, IL 62225

12. Steven Wourms 1
ASC/YN
2275, D Steet, Suite 16
Wright Patterson AFB, OH 45433-7233

13. OA Branch, APD (Attn: CPT Lim Teo Weng) 2
HQ RSAF
MINDEF Building
Gombak Drive, Singapore 2366
Republic of Singapore