

AD-A286 686



OTS: 60-11,840

JPRS: 2950

5 July 1960

COPY 1

PRODUCTION AND PHYSICAL METALLURGY OF
PURE METALS -- PART II

- USSR -

by V. S. Yemel'yanov, A. I. Yevstyukhin,
D. D. Abanin and V. I. Statsenko

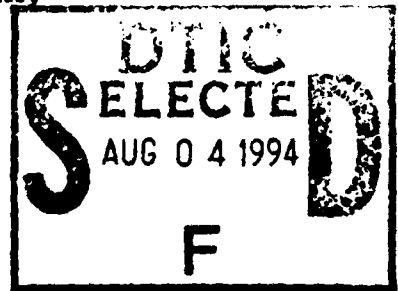

94-24648



248

LIBRARY

JUL 24 1960

Distributed by:

OFFICE OF TECHNICAL SERVICES
U. S. DEPARTMENT OF COMMERCE
WASHINGTON 25, D. C.

This document has been approved
for public release and sale; its
distribution is unlimited.

~~Price: \$0.75~~

U. S. JOINT PUBLICATIONS RESEARCH SERVICE
205 EAST 42nd STREET, SUITE 300
NEW YORK 17, N. Y.

DTIC QUALITY INSPECTED 1

94 8 03 075

4
N-847-60
84760
pt 2

**Best
Available
Copy**

JPRS: 2950

CSO: 3913-N/4

PRODUCTION AND PHYSICAL METALLURGY OF
PURE METALS -- PART II

AN IMPROVED METHOD OF PREPARING IODIDE CHROMIUM
AND ITS PROPERTIES

This is a translation of an article written by V. S. Yemel'yanov, A. I. Yevstyukhin, D. D. Abanin and V. I. Statsenko in Metallurgiya i Metallovedeniye Chistykh Metallov (Production and Physical Metallurgy of Pure Metals), No. 1, Moscow, 1959, pages 44-62.7

Ductile chromium is of considerable interest to numerous branches of technology. Not until recently, however, has it been used as a structural metal, either in pure form or in alloys based on the pure form.

This is to be explained by the fact that aluminothermic chromium, as well as electrolytic chromium, as prepared at present is brittle and cannot be worked at room temperature. It has been used only for alloying steel and other alloys. Among the recent known methods of chromium refining, annealing in an atmosphere of hydrogen, vacuum distillation, and the iodide method are worth noting. Despite the considerable attention paid by researchers to the two former methods, they do not yield chromium ductile at room temperature.

Iodide refining of chromium, to which, regrettably, our researchers have not paid adequate attention, permits successful refining of the metal from many nonmetallic admixtures. According to data in the literature, this method produces chromium entirely usable for rolling and forging. Sheets of iodide chromium withstand bending to 180° at room temperature [1]. Remelted in an arc furnace, iodide chromium shows a limit brittleness threshold at a temperature under -25°C [2]. After deformation, at room temperature this chromium has an elongation factor of 40% [3]. However, no details regarding the apparatus and process for preparing iodide chromium are available in

| |
|-------------------------------------|
| <input checked="" type="checkbox"/> |
| <input type="checkbox"/> |
| <input type="checkbox"/> |
| |
| |
| |
| Codes |

| | | |
|------|---------|----|
| Dist | Special | or |
| A-1 | | |

literature. The scarcity of works dedicated to the study of iodide refining of chromium apparently can be explained by experimental difficulties. According to Van Arkel and de Bour, the use of conventional apparatus for iodide refining of chromium is impossible due to the softening of glass at the high temperature of the process. Substitution of quartz for glass was unsuccessful due to the complication of welding current-conducting metal electrodes into quartz, and due to the diffusion of gases through the walls which are externally heated to high temperatures.

Our laboratory has designed an improved laboratory device made of quartz, for iodide refining of chromium and analagous metals which is free from these defects. Using this apparatus we have succeeded in obtaining a reliable production of iodide chromium (more than 120 g during one test).

We received a sufficient quantity of iodide chromium to study its properties, and we also investigated certain conditions for carrying out the process. It was established that iodide chromium, remelted in an arc furnace and cast, has, at room temperature, an elongation of about 17% and an area reduction of 23%, while the brittleness threshold is at a temperature lower than -15°C .

Design Of The Device

In the quartz apparatus designed by us, chromium is deposited on a glowing filament, as is usual in such cases. However, it is not necessary to weld or to introduce metallic electrodes through orifices into our apparatus in order to supply heating current to the filament, which simplifies considerably the technique of the experiment. Into a quartz flask welded at the two ends is placed a helix of thick (2-4 mm) tungsten or molybdenum wire with a thin tungsten heating filament affixed to both its ends.

The principle of action of this apparatus is based on the excitation of high-frequency currents in this helix by means of the inductor of a high-frequency generator placed outside the flask. The whole electrical heating circuit of the filament is a sort of transformer in which the inductor, together with the generator, is the primary circuit while the helix with the heating filament is the secondary circuit (Fig. 1).

As it appears from the figure, the installation is a cylindrical quartz flask preliminarily pumped out to a vacuum of not less than 10^{-4} mm Hg and then welded off from the vacuum system; there are two tubular heating furnaces and a high-frequency installation (in our case of

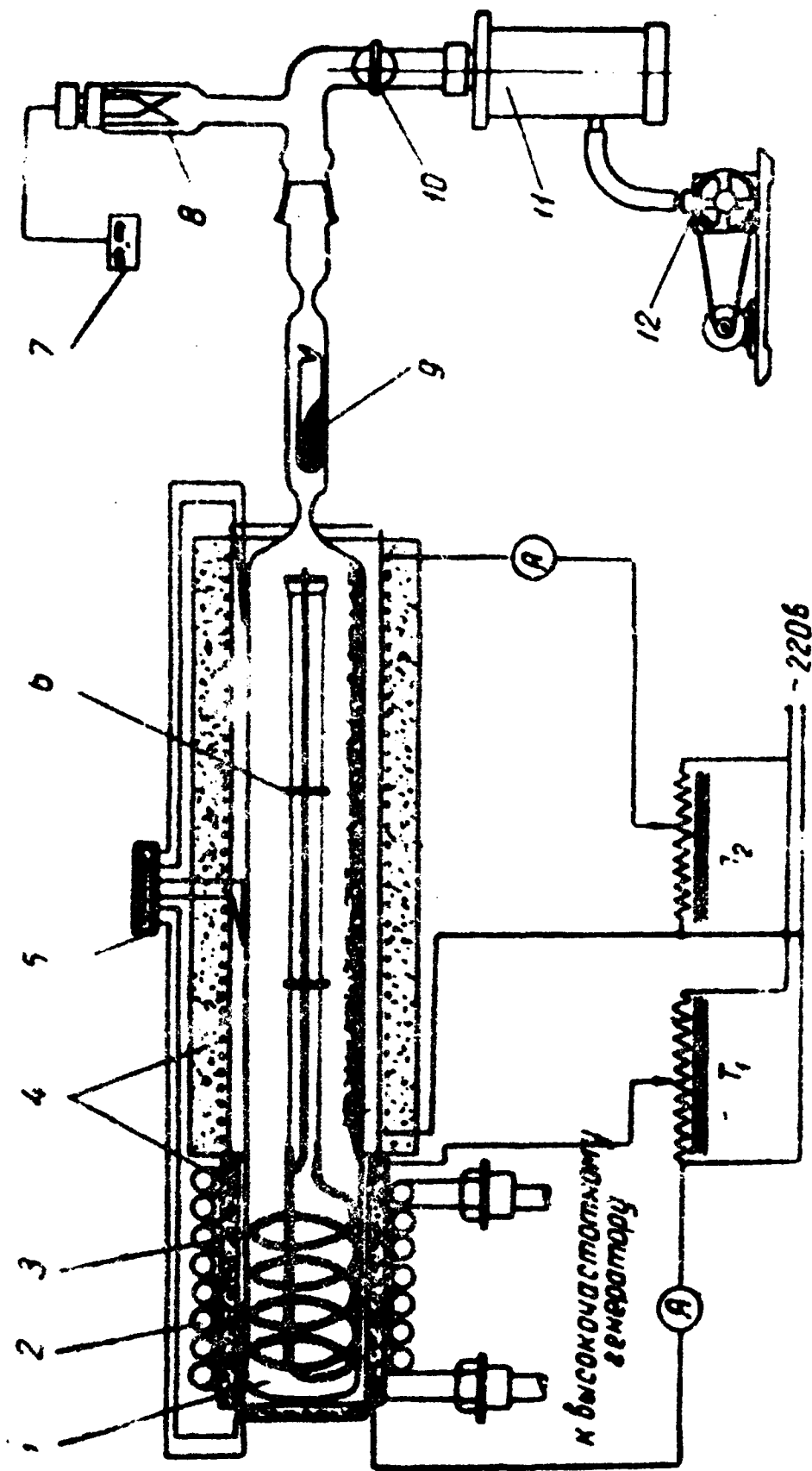

Fig. 1. Diagram of installation for iodide chromium refining: 1, Quartz flask; 2, inductor of hf generator; 3, helix of thick tungsten or molybdenum wire; 4, furnaces with nichrome heating elements; 5, thermocouple galvanometer; 6, porcelain insulators supporting the filament; 7, thermocouple galvanometer; 8, ionization gauge; 9, ampoule with iodine crystals; 10, valve; 11, diffusion pump; 12, pre-vacuum pump; T₁ and T₂, laboratory autotransformers (feeder voltage regulation).

the type MVP-3M). Inside the flask at one end is placed a helical inductor wound from thick molybdenum or tungsten wire. In our case, the inductor had 4-5 turns. The diameter and the length of the flask, as well as the diameter and the number of coils of the inductor, can be varied depending on the production required (in our case, the flask had a diameter of 50 mm and a length of 800 mm).

Figure 2 shows the exterior view of the helical inductor, with the holder and chromium deposited on the tungsten wire.

The heating filament was connected to the ends of the inductor by means of tungsten pins, to create a smooth transition from the thin filament to the inductor. The filament was suspended, by means of porcelain insulators, from a holder made of molybdenum or tungsten wire. This holder in turn was secured at one end to the inductor while the other end abutted against the wall of the quartz flask. The inductor of the high-frequency generator was placed outside the end of the flask containing the interior inductor. This end was heated by a separate furnace during the refining.

The flask itself was placed in a large tubular furnace with a port through which, by means of an optical pyrometer, the temperature of the filament was measured. Heating of the furnaces was regulated by an autotransformer.

Preparation Of The Flask

Degassing of the electrolytic chromium before iodide refining was done in the refining flask. For this purpose, to the end of the quartz flask opposite the inductor was welded a quartz tube, into which a glass ampoule with crystalline iodine was inserted.

The other end of this tube was connected to the vacuum system. Pumping out the flask was done by simultaneously heating electrolytic chromium scales to 850-900°C for several hours. When the required vacuum was attained, the flask was welded off from the vacuum system. When the flask had cooled, the iodine ampoule was broken. Then, by short bursts of heating over a gas burner, iodine was sublimed into the flask and the tube was then welded off from the flask.

In this way the flask was made ready to carry out iodide refining.

At the end of the process certain parts of the inside of the flask were covered with a layer of dark purple iodide and green chromium oxide. Before using it in a new cycle, the flask was washed with water which readily dis-



Fig. 2. Inductor with holder and chromium deposited on the tungsten filament.

solves iodide. However, the chromium oxide film could not be dissolved in water or acids or alkali. It was eliminated by fusing it with potassium pyrosulfate, or sodium nitrate over the flame of a burner.

Starting The Apparatus For Iodide Refining and Regulation Of Imposed Power

To prepare chromium iodide before refining it, a part of the flask was heated in a furnace to 800°C while the other part remained unheated so that the iodine that had not reacted with chromium could be condensed therein. If this is not done, the iodine, which has great vapor tension at 800°C , can explode the flask. After chromium iodide had been formed in the heated portion of the flask, the cold part of the flask heated slowly by an auxiliary furnace

so as to equalize the temperature along its full length. This caused the remaining free iodine to enter into reaction with chromium to form iodides.

After this step was completed, the high-frequency generator could be switched on. Now current circulates through the heating filaments and, by regulating the imposed power, one can achieve the required heating filament temperature.

In the course of refining, the filament grows thicker and its electric resistivity changes, requiring greater power to maintain a given temperature. This is achieved by an increasing the anode current in the generator tube. Under these circumstances, the temperature of the heating filament is held almost constant over the entire course of its thickening. As it grows thicker, the filament consumes an increasing amount of power which requires that power regulation be imposed on the primary inductor. The thicker the filament becomes, the more heat it radiates into the surrounding space and the greater is the additional heat required because of radiation. In this case, the required temperature of the flask is maintained by control of the external heating by the furnace. It is usual that by the end of the process heat radiation from the filament is so high that external heating becomes unnecessary and the furnace is switched off.

Establishment Of The Temperature Regime Of The Process

A series of tests established the temperature interval for the filament and flask over which it is possible to carry out iodide refining of chromium.

Thermal deposition of chromium iodide on the heated filament begins at 1000°C . The maximum temperature at which deposition of chromium still occurs is 1200°C . At higher temperatures of the filament, no noticeable increase in thickness of the filament takes place. The minimum flask temperature at which the process could be observed was 750°C . The flask was not heated higher than 950°C as there was a danger of diffusion of atmospheric gases through the walls of the quartz flask.

The temperature of the walls of the flask was measured at three different points by thermocouples.

The temperature of the filament was measured with an optical pyrometer OPPIR-09; the measurement was not accurate however, due to the fact that the correction for light absorption by chromium iodide vapors is unknown. Only a correction for light absorption by the walls of the quartz

flask. It is necessary to note that the determination of the filament temperature during the process is very difficult, as iodide vapors absorb visible light and the walls of the flask are frequently covered by a sediment.

As a result of the tests carried out, a temperature regime was established at which iodide chromium is prepared under optimum conditions. The flask temperature must be maintained in the range of 300-850°C and the filament must have a temperature of 1100-1150°C.

Typical currents for the beginning of the process at the anode of generator tube are 0.5-0.6 amp 5 and for the end of the process 1.6-1.8 amp.

A Study Of The Properties Of Chromium Iodides And Of The Mechanics Of Iodide Refining

Data on chromium iodides in the literature are very scant. The system Cr-I has not been studied. It is known that at room temperature only the lowest iodide, CrI_2 , is stable; this is a "light gray" substance, hygroscopic in air and well soluble in water, having a density of 5.2 g/cm^3 and an m.p. of 783°C [47]. Higher chromium iodides, CrI_3 and CrI_4 , are unstable at room temperature and their properties were not studied. We have studied the formation and the behavior of chromium iodides during heating of chromium and iodine in welded quartz ampoules as well as during iodide refining of chromium.

It was established that during the heating of a quartz ampoule over the flame of a gas burner, a deposition of iodides occurs on the walls of the ampoule; on the less heated parts, iodides of three colors (dark purple, red-brown and yellow) are deposited.

If one cools a part of the reaction flask that can be seen through the side port (for instance, by blowing cold air out), at the cooled spots appear first yellow, then red-brown, and finally dark purple spots, which are iodides. After cooling is stopped, the first to disappear are the dark brown spots, then the red-brown and, last, the yellow.

Chromium iodide, which is stable at room temperature, is a dark purple substance; we never observed the "light gray" iodide mentioned in literature. It sublimes at a temperature of 800°C. When the flask for refining chromium is cooled, iodide condenses on the inner surfaces. It is very hygroscopic and well soluble in water. According to the chemical analysis made in our laboratory, its composition corresponds to the stoichiometric formula CrI_2 .

The reddish-brown chromium iodide is evidently chromium triiodide, CrI_3 . This iodide could not be found at room temperature. The yellow chromium iodide is evidently the

tetraiodide, CrI_4 , which likewise could not be formed at room temperature and therefore was not analyzed.

Taking into consideration that as the valence of the metal ions increases, the stability of the iodides decreases and their volatility increases, we can suppose that CrI_4 is the iodide that is thermally most unstable and most volatile. While it is not exactly known which chromium iodide is of greatest importance in the process of refining, one can imagine that the basic role is played here by the more volatile iodides CrI_3 and CrI_4 . On the basis of the above, the chemistry of iodide chromium refining can be represented by the following equations:

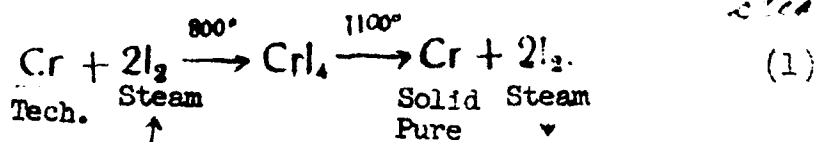

steam 2000

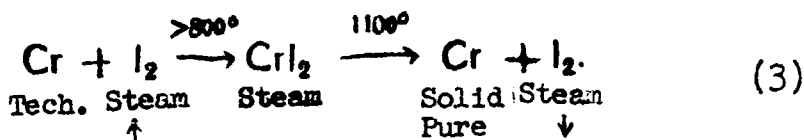
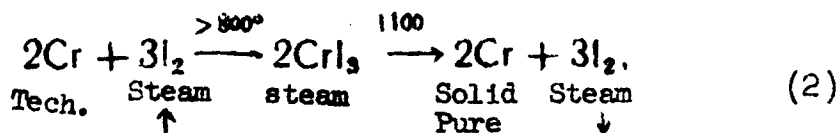

Considering that the lower chromium iodides CrI_3 and CrI_2 are less volatile and thermally more stable, the most important reaction in refining is probably (1). It is possible that intermediate reactions also take place.

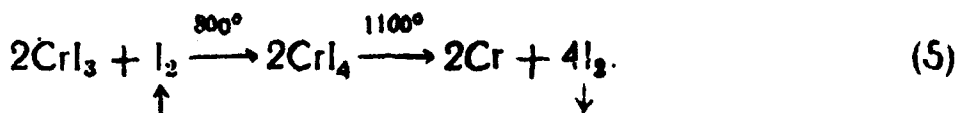
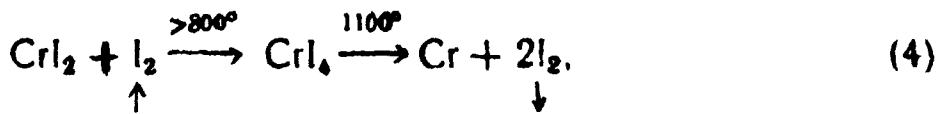

However, more accurate data about these reactions will be obtained after a study is made of the system Cr-I and of the thermodynamics of chromium iodide.

Results Of Refining Tests

The original electrolytic chromium, in the form of scales, is charged in a flask in a quantity of 200-250 g. Five to six grams of crystalline iodine is introduced into the flask for carrying out the reaction. The average rod of crystalline iodide chromium obtained during one experiment was 5-6 mm in diameter and 125-135 cm long. The weight of such a rod was 120-140 g, accumulated over a period of 15-20 hrs. After opening the flask upon completion of the iodide refining, it was found that the remainder of the initial electrolytic chromium is coated with a dark gray powder. As established by analysis, this gray powder contains a higher quantity of gaseous admixtures (nitrogen, oxygen and hydrogen) than does the initial metal. Undoubtedly, in the course of iodide refining of chromium, an elimination of these detrimental admixtures takes place which has a decisive influence on the brittleness of the metal.

The results of chemical analysis of typical samples of initial and refined iodide chromium, as shown in Table 1, confirms this thought.

As the table shows, the elimination of oxygen after a one cycle of iodide refining resulted in elimination of all but 1/30th of the oxygen, while 1/10th of the initial content of nitrogen and hydrogen remained.

After remelting in an arc furnace of our design, iodide chromium was again contaminated by atmospheric oxygen to ten times its previous level, while one-thousandth of 1% of nitrogen was added.

It was noticed that, during arc melting, chromium sublimates somewhat and condenses on the cold walls of the furnace.

Vapors of sublimated chromium can be used as a good getter, which is very important in melting on large scale.

For a comparison of the degrees of purity of iodide chromium obtained by us and by other researchers, Table 1 contains data of analysis taken from published works [3], [5], and [2]. It appears that iodide chromium, as prepared by us, contains considerably less nitrogen, oxygen and hydrogen than mentioned in works [5] and [2], but about one order more than in work [3].

In Table 2 are shown data of chemical analysis for metallic admixtures in the initial electrolytic and in the final iodide chromium.

Table 1

Contents of nonmetallic admixtures* in chromium
of different origins

| Chromium | Admixture content, % by wt. | | | |
|---|-------------------------------|----------------|----------------|--------|
| | N ₂ | O ₂ | H ₂ | C |
| Electrolytic, degassed, initial metal for io- dide refining | 0.0400 | 0.0300 | 0.0040 | 0.0000 |
| Crystalline iodide chrom- ium after deposition on tungsten filament | 0.0030 | 0.0012 | 0.00045 | 0.0000 |
| Gray powder remaining on the refining flask bot- tom after iodide refin- ing at the surface of unreacted chromium | 0.7430 | 0.7980 | 0.0268 | — |
| Iodide chromium remelted in arc furnace in argon atmosphere | 0.0040 | 0.0100 | 0.0005 | 0.0000 |
| Iodide chromium depos- ited on quartz [5] | 0.0150 | 0.0270 | — | — |
| Iodide chromium accord- ing to foreign sources [2] | 0.0130 | 0.0140 | 0.0090 | — |
| Iodide chromium accord- ing to foreign sources [e] | $\Sigma (N_2 + O_2) = 0.0105$ | | | |

*Analysis was made in the VIAM laboratory.

Table 2

Content of metallic admixtures in electrolytic and
iodide chromium

| Admixture | Content, % by wt. | |
|------------|-------------------|-----------|
| | Electrolytic | Iodide |
| Iron | 0.0350 | 0.0000 |
| Copper | 0.0065 | 0.0030 |
| Silicon | 0.0400 | traces |
| Titanium | 0.0400 | traces |
| Aluminum | 0.0200 | 0.0200 |
| Lead | 0.0017 | 0.0017 |
| Bismuth | 0.00008 | 0.000035 |
| Cadmium | 0.00015 | 0.00019 |
| Manganese | not analyzed | not found |
| Tungsten | " | " |
| Vanadium | " | " |
| Antimony | " | " |
| Nickel | " | " |
| Zinc | " | " |
| Molybdenum | " | " |

*Analysis was made in the VIAM laboratory.

As it appears from the table, iodide refining eliminates silicon, titanium, copper and iron but not aluminum, lead, bismuth and cadmium. No admixture of

manganese, nickel, vanadium, molybdenum, tungsten, arsenic, antimony and boron were found in iodide chromium. However, the initial electrolytic chromium was not analyzed for the content of these admixtures. Therefore, a comparison of the degree of purity of the iodide- and initial metals cannot be made.

Chromium Crystallization From Gaseous Phase Of Chromium Iodide

Unlike zirconium, titanium, and hafnium, chromium, in the refining of its iodide, is not deposited on the filament in the shape of a compact rod. As it appears from Fig. 2, it grows in the shape of single crystals sticking to each other. The size of separate crystals reaches 4-4.5 mm. In form, under normal conditions of pumping and processing, they are mostly regular octahedra and prisms (Fig. 3). When deviations from normal conditions occur -- for instance, when vacuum is not complete or humidity penetrates the flask -- chromium crystallization on the filament becomes different. In this case, dendrites, single stalactite-shaped monocrystals, wedge- and sword-shaped crystals, etc., may grow (Fig. 4a, b, c).

It was observed that under normal conditions, in the beginning of the process, very small crystals were deposited on the filament. It is evident that in this case a great number of crystallization centers are formed.

As crystallization of chromium on the filament proceeds, the number of crystallization centers decreases. The size of crystals increases and their number decreases. Chromium crystals, during the process of their formation, take on different but regular forms.

If additional crystallization centers are formed on the new crystals, new crystals begin to grow on these newly formed centers. On these crystals, in turn, new crystallization centers are formed. As a result, the crystals grow together into complex crystalline forms.

A microscopic investigation of crystals so obtained shows that their surface has a laminar character. In Fig. 5 a, b, and c, microphotographs are shown of the surface of iodide chromium crystals. A visual observation of iodide chromium rods shows that the longest and largest chromium crystals extend in the direction of the location of the raw metal. It is evident that the distance between the filament and the raw metal substantially influences chromium crystallization.

With the increase in thickness of the filament in the course of the process, heat radiation from the filament



Fig. 3. Crystalline rod of iodide chromium (X2).

into the environment increases.

To maintain the temperature of the flask at a constant level, the outside heating is decreased and then later on entirely switched off. The walls of the flask are then heated predominantly by heat radiation from the filament. In those places where the filament sags, heat radiation from it onto the raw metal increases. This leads to an increase in the raw metal temperature, which speeds up the reaction between chromium and iodine. At the lowest sagging points of the filament the longest and largest crystals were observed. In some cases, separate crystals or, rather, dendrite-shaped crystalline forms touched the raw metal and even stuck to it. On the side of the rod, opposite the raw metal, no long and large chromium crystals were formed; the majority of crystals there were small and flat. The finest crystals were observed in those sections of the rod which were most distant from the raw metal.

A radiogram of iodide chromium monocrystals obtained under normal conditions, and also one of powders remelted in an arc furnace, showed that chrom-



a



b

Fig. 4. Chromium crystals growing on the surface of the rod when vacuum is incomplete or humidity is present:

- a) fir-shaped acicular crystals
- b) fir-shaped sword-like crystals

Fig. 4 and legend continued on next page



8

Fig. 4. Chromium crystals growing on the surface of the rod when vacuum is incomplete or humidity is present:

c) stalactite-shaped crystals

ium has a body-centered cubic space lattice with an "a" parameter at room temperature equal to 2.8790 \pm 0.001 kX.

Crystals of iodide chromium obtained in one of the tests under defective vacuum (when humidity penetrated into the flask) had a hexagon lattice with a parameter $a_0 = 2.349$ kX.

Structure and Mechanical Properties Of Iodide Chromium

From samples of iodide chromium remelted in an arc furnace, slides were prepared. Study of the slides showed that cast chromium has a coarse, grained structure. The grain boundaries are very fine, which shows the great purity of the metal. Photographs of the microstructure of iodide chromium and that of initial electrolytic metal are shown in Figs. 6 and 7.



Fig. 5. Laminar structure of iodide chromium crystals:

- a) structure of an electrolytically etched sample (X500)
- b) surface structure of a nonetched sample (X500)
- c) surface structure of a nonetched sample (X100)

The hardness of iodide chromium remelted in a MIFI-9-3 electric furnace varied over the range of 100-120 H_B . From iodide chromium remelted in an arc furnace tensile strength samples were prepared and

tested in Gagarin press and an elongation diagram was recorded (Fig. 8). The deformation speed was 5 mm/min.

The results of room temperature tests of three such samples are shown in Table 3, from which it appears that the tensile strength of iodide chromium in castings varies from 13.0 to 20.5 kg/mm².

The tensile strength of remelted iodide chromium, as determined by the so-called samples method, was found to be 19.8 kg/cm² at room temperature.

The threshold of brittleness of arc-remelted iodide chromium was determined by static bending. The determination was carried out with samples 25 mm long and 2.5 mm in diameter. Before the test, samples were machined to the required size on the lathe and were subjected to electro-polishing to eliminate surface flaws. The determination of the threshold of brittleness was done according to the methods worked out at VIAM under the direction of Y. B. Fridman.

One of the samples of cast iodide chromium, when tested for bending at -15°C, was not destroyed. The arrow of the bend during the test was 3 mm. The speed of deformation was 0.5 mm/min.

Another sample was tested for bending under the same conditions but at a temperature of -25°C. At this temperature, the sample was destroyed. However, the character of the break shows that the sample was bent to a small extent during the initial moment of the test, and then broke down.

Radiograms of deformed and nondeformed sections of the samples at the place of the break have shown that the deformation of the sample during the bending test followed the pattern of twining. This definitely indicates that plastic deformation was taking place.

Thus, tests have shown that the threshold of brittleness of cast iodide chromium actually lies in an area bordering on -25°C.

The values obtained by us for cast iodide chromium tensile strength, yield point, elongation and reduction of area at room temperature are comparable with data of the usual so-called ductile metals. It is evident that these values would be even better if iodide chromium were not contaminated by oxygen and nitrogen during remelting, and undoubtedly they would be still better if tensile strength tests were made with samples previously deformed, not cast for technical reasons, however, the latter could not be done.

Data on the ductility of iodide chromium obtained by us seems very promising especially since electrolytic

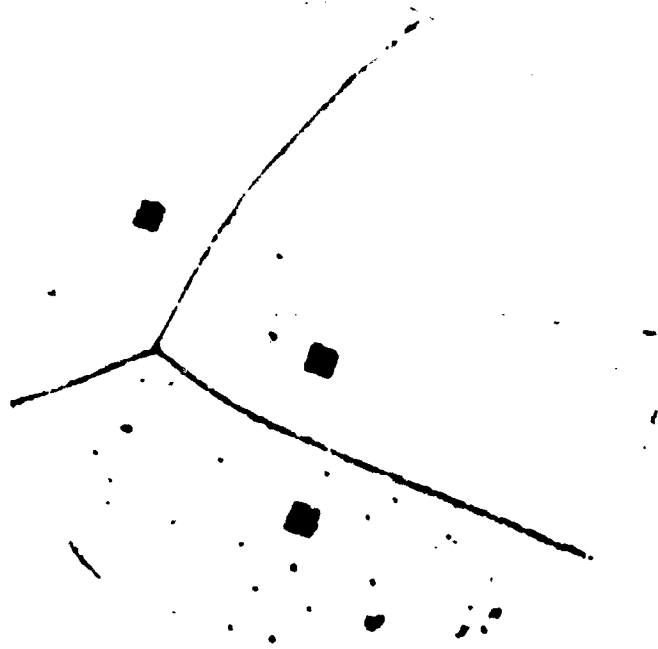

Fig. 6. Microstructure of iodide chromium (X200).

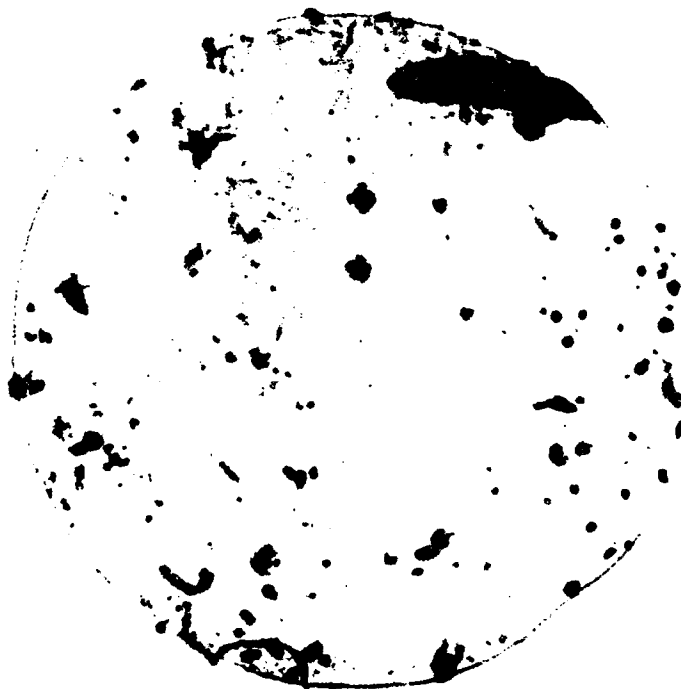

Fig. 7. Microstructure of electrolytic chromium (X200).

Table 3

Mechanical properties of remelted iodide chromium^(*)

| Size of sample before test | | | Size of sample after test | | |
|-------------------------------|--------|----------------|------------------------------|--------|----------------|
| Diam. | Length | Cross Sect. | Neck diam | Length | Cross Sect. |
| mm | mm | mm | mm | mm | mm |
| 2.95 | 32.8 | 6.8 | 2.70 | 34.3 | 5.7 |
| 3.07 | 33.4 | 7.4 | 2.93 | 35.0 | 6.7 |
| 5.4 | 38.35 | 20 | 4.45 | 42.5 | — |

(*) Tests for resistance of materials were made at VIAM laboratory.

Table 3 continued
on next page

[Continued from Page 19]

| Yield point | | Tensile Strength | | Rel. Elongat. of 5d length % | Full reduct. of cross section % |
|-------------|------------------------------|------------------|------------------------------|---------------------------------|------------------------------------|
| Load kg | Stress kg/mm ² | Load kg | Stress kg/mm ² | | |
| 138 | 20.3 | 192 | 28.2 | 8.8 | 16.2 |
| 152 | 20.5 | 201 | 27.6 | 9.4 | 9.4 |
| 260 | 13.0 | 390 | 19.5 | 16.6 | 22.9 |

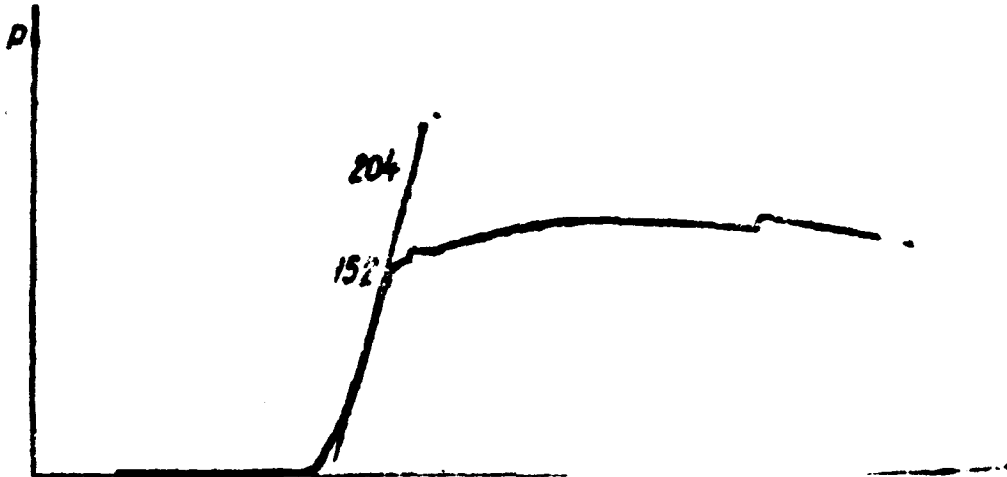

Fig. 8. Elongation diagram of cast iodide chromium sample.

chromium, remelted under the same conditions and refined by annealing in hydrogen and distillation in vacuum, is destroyed in tensile strength tests with zero elongation.

Conclusions

1. A new design of a laboratory installation for iodide refining of chromium was worked out and tested. It does not require welding metal electrodes into the reaction flask to pass electric current to the heated filament. The installation is able to prepare, during one cycle lasting 15-20 hrs., crystalline rods of iodide chromium weighing 100 to 140 g. Iodide refining of chromium as devised above can be applied to semi-industrial production.
2. Basic optimum conditions for carrying out iodide refining of chromium were established. During the process the temperature of the flask must be maintained within the range of 800-850°C, and the temperature of the filament within the range of 1100-1150°C.
3. On the basis of a study of chromium iodide properties and observations on the course of the chromium preparation process, an outline of the mechanics of the process of iodide refining of chromium was submitted.

4. A chemical analysis for nitrogen, oxygen and hydrogen admixtures in the initial electrolytic- and iodide chromium obtained from it showed that during iodide refining chromium is considerably purified from gaseous admixtures. In one cycle of iodide refining, purification removes 29/30, of the oxygen content while all but 10-12% of the nitrogen and hydrogen is removed. To obtain chromium with a still lower content of gaseous admixtures, two- or three-cycle iodide refining will be required. The purity of iodide chromium so obtained is confirmed by metallographic analysis of monocrystals and of the metal remelted in an arc furnace.

5. A study of the mechanical properties of samples of iodide chromium prepared and remelted in an arc furnace showed that the cast metal has a threshold of cold brittleness at about -25°C . The micro furnace of iodide chromium monocrystals changed from 95 to 100 kg/mm² (at a load of 20 g). The hardness of this iodide chromium varied within 100-120 H_B; the yield point at room temperature varied from 13 to 20.5 kg/mm²; the tensile strength was 19.5-28.2 kg/mm², the elongation 8.8-16.6%, and the reduction of area 9.4-22.9%.

6. Monocrystals of chromium iodide and the metal remelted in an arc furnace were body-centered cubic with parameter "a" at room temperature equal to 2.8790 Å .001 kX. Crystals of hexagonal chromium prepared in our tests were evidently one of chromium hydrides or possibly another compound of this metal.

Bibliography

1. Metody polucheniya chistykh metallov (A collection: Methods of Preparing Pure Metals), V. S. Yemel'yanov and A. I. Yevstyukhin, Editors, IL, M., 1957, p. 10
2. Problemy sovremennoy metallurgiyi (Problems of Modern Metallurgy) IL, 1956, vol. 3, p. 90
3. D. J. Maykuth, R. J. Jaffe, Trans. ASM (1956)
4. The Chemistry and Metallurgy of Miscellaneous Materials. Thermodynamics, ed. by L. Quill, New York (1950).
5. N. V. Ageyev, V. A. Trapeznikov. Polucheniye iodidnogo khroma i ego svoystva (Preparation of Iodide Chromium and its Properties. Investigations of Refractory Alloys) M., 1956

6. A. I. Yevstyukhin, G. A. Leontyev, V. V. Nikishanov,
Dugovaya plavka tugoplavkikh metallov i splavov v
laboratornykh usloviyakh (Arc Melting of Refractory
Metals and Alloys) see p. 106 of this collection.

- E N D -

#1766

- 23 -

FOR REASONS OF SPEED AND ECONOMY
THIS REPORT HAS BEEN REPRODUCED
ELECTRONICALLY DIRECTLY FROM OUR
CONTRACTOR'S TYPESCRIPT

THIS PUBLICATION WAS PREPARED UNDER CONTRACT TO THE
UNITED STATES JOINT PUBLICATIONS RESEARCH SERVICE
A FEDERAL GOVERNMENT ORGANIZATION ESTABLISHED
TO SERVICE THE TRANSLATION AND RESEARCH NEEDS
OF THE VARIOUS GOVERNMENT DEPARTMENTS