

RL-TR-94-149
In-House Report
September 1994

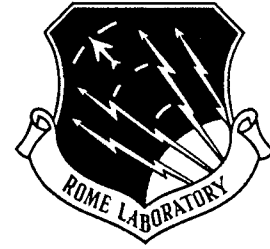

ACT ADAPTIVE FILTERS

Siamak S. Tabrizi

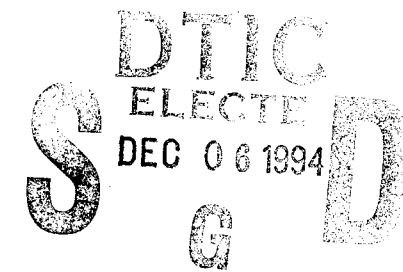

APPROVED FOR PUBLIC RELEASE; DISTRIBUTION UNLIMITED.

DTIC QUALITY INSPECTED 6

Rome Laboratory
Air Force Materiel Command
Griffiss Air Force Base, New York

19941129 053

This report has been reviewed by the Rome Laboratory Public Affairs Office (PA) and is releasable to the National Technical Information Service (NTIS). At NTIS it will be releasable to the general public, including foreign nations.

RL-TR-94-149 has been reviewed and is approved for publication.

APPROVED:

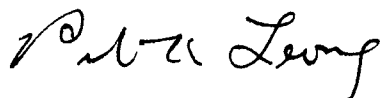

PETER K. LEONG, Acting Chief
Communications Division
Command, Control, & Communications Directorate

FOR THE COMMANDER:

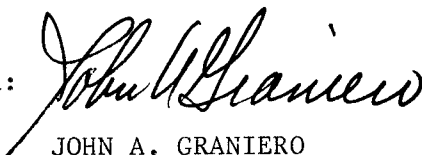

JOHN A. GRANIERO
Chief Scientist
Command, Control, & Communications Directorate

If your address has changed or if you wish to be removed from the Rome Laboratory mailing list, or if the addressee is no longer employed by your organization, please notify RL (C3BB) Griffiss AFB NY 13441. This will assist us in maintaining a current mailing list.

Do not return copies of this report unless contractual obligations or notices on a specific document require that it be returned.

REPORT DOCUMENTATION PAGE

Form Approved
OMB No. 0704-0188

Public reporting burden for this collection of information is estimated to average 1 hour per response, including the time for reviewing instructions, searching existing data sources, gathering and maintaining the data needed, and completing and reviewing the collection of information. Send comments regarding this burden estimate or any other aspect of this collection of information, including suggestions for reducing this burden, to Washington Headquarters Services, Directorate for Information Operations and Reports, 1215 Jefferson Davis Highway, Suite 1204, Arlington, VA 22202-4302, and to the Office of Management and Budget, Paperwork Reduction Project (0704-0188), Washington, DC 20503.

1. AGENCY USE ONLY (Leave Blank)		2. REPORT DATE September 1994		3. REPORT TYPE AND DATES COVERED In-House Aug 89 - Jul 94	
4. TITLE AND SUBTITLE ACT ADAPTIVE FILTERS				5. FUNDING NUMBERS PE - 62702F PR - 4519 TA - 42 WU - 75	
6. AUTHOR(S) Siamak S. Tabrizi					
7. PERFORMING ORGANIZATION NAME(S) AND ADDRESS(ES) Rome Laboratory (C3BB) 525 Brooks Road Griffiss AFB NY 13441-4505				8. PERFORMING ORGANIZATION REPORT NUMBER RL-TR-94-149	
9. SPONSORING/MONITORING AGENCY NAME(S) AND ADDRESS(ES) Rome Laboratory (C3BB) 525 Brooks Road Griffiss AFB NY 13441-4505				10. SPONSORING/MONITORING AGENCY REPORT NUMBER	
11. SUPPLEMENTARY NOTES Rome Laboratory Project Engineer: Siamak S. Tabrizi/C3BB (315) 330-4823					
12a. DISTRIBUTION/AVAILABILITY STATEMENT DOD and DOD contractors only; critical technology, Sep 94. Other requests RL (C3BB), 525 Brooks Road, Griffiss AFB NY 13441-4505.				12b. DISTRIBUTION CODE	
13. ABSTRACT (Maximum 200 words) This report investigates the Acoustic Charge Transport (ACT) Programmable Transversal Filter (PTF) with 128 taps each having a 5-bit tap precision. ACT devices can be used for Finite Impulse Response (FIR) adaptive filtering. The objective of this report is to document the implementation of an adaptive filter with ACT device using a Linear Random Search (LRS) adaptive algorithm, and its performance. The LRS algorithm was evaluated for a single Continuous-Wave (CW) tone interferer, and its performance (null depth) was compared to theoretical predictions. Specifically, the rate of convergence and filter response after adaptation was simulated using MATLAB and the results were compared to that obtained experimentally.					
14. SUBJECT TERMS Acoustic Charge Transport (ACT), Adaptive Filtering, Linear Random Search Algorithm				15. NUMBER OF PAGES 36	
				16. PRICE CODE	
17. SECURITY CLASSIFICATION OF REPORT UNCLASSIFIED		18. SECURITY CLASSIFICATION OF THIS PAGE UNCLASSIFIED		19. SECURITY CLASSIFICATION OF ABSTRACT UNCLASSIFIED	
				20. LIMITATION OF ABSTRACT U/L	

Table of Contents

<u>Section</u>	<u>Page</u>
1.0 Introduction	2
2.1 Acoustic Charge Transport (ACT)	3
2.2 The ACT Programmable Transversal Filter	4
2.3 Adaptive Interference Canceller	5
3.1 Computer Simulation of the Linear Random Search Algorithm	7
3.2 Linear Random Search Algorithm Implementation	8
4.1 Results of the Computer Modeling and Experimental Analyses	12
5.0 Conclusion	26
6.0 References	27

Accession For	
NTIS CRA&I	<input checked="" type="checkbox"/>
DTIC TAB	<input type="checkbox"/>
Unannounced	<input type="checkbox"/>
Justification	
By	
Distribution /	
Availability Codes	
Dist	Avail and / or Special
A-1	

1.0 INTRODUCTION

The objective of this report is to document the implementation of an adaptive filter with Acoustic Charge Transport (ACT) device using a Linear Random Search (LRS) algorithm, and its performance. The ACT used is a programmable analog transversal filter with 128 taps each having a 5-bit tap precision. The tap weights are set dynamically by a digital controller. Because of the programmability of ACT devices, they can be utilized for Finite Impulse Response (FIR) adaptive filtering. The focus of the effort is to measure the amount of rejection, or null depth, obtainable when ACT adaptive filters are used in the suppression of a single Continuous-Wave (CW) tone. The LRS algorithm was evaluated for a single CW tone interferer, and its performance (null depth) was compared to theoretical predictions. Specifically, the rate of convergence and filter response after adaptation was simulated using MATLAB and the results were compared to that obtained experimentally. Additional software was developed to load and initialize the ACT device with predefined filter coefficients, and to aid the process of transferring data via IEEE-488 (GPIB) interface bus from spectrum and network analyzers to the computer as data files for the purpose of storing and printing results.

2.1 ACOUSTIC CHARGE TRANSPORT (ACT)

ACT is an analog signal processing technology implemented in gallium arsenide (GaAs). ACT technology is based on two analog device technologies: Surface Acoustic Wave (SAW) and Charge Coupled Device (CCD) technologies.

SAW devices are passive devices that are intrinsically bandpass filters. They have high dynamic range, and are capable of very wide bandwidths and independent specification of amplitude and phase characteristics. The insertion loss of a SAW device is often proportional to the bandwidth.

CCDs are active semiconductor devices in which charge packets representing samples of an input signal waveform are transferred between potential "wells" in the semiconductor. The CCD devices are capable of attaining modest dynamic range levels, limited by noise and linearity considerations in the input and output circuit ports.

The ACT input sampling rate is determined by the SAW frequency. SAW devices function as a built-in clock signal to power the charge transfer of electrons in the CCD semiconductor devices. Charge packets, carried down the channel by the acoustic wave (at the sound velocity), induce small image charges in the tap electrodes. Each charge is proportional to the number of electrons that packet contains. Therefore, ACT device is considered a buried channel CCD in which charge is transported from an input terminal to an output terminal by a travelling wave potential induced in a semiconductor by a SAW. A more detailed explanation of ACT devices can be found in [1].

ACT channels can contain hundreds of programmable or fixed taps. The basis of ACT's processing ability is the discretely-sampled charge-sensing process of the input signal by these taps. The charge-sensing process is non-destructive and the charge packets lose only a negligible number of electrons as they transit the channel. Therefore the ACT transport channel provides a wideband tapped delay line.

A most common application of the ACT is the Programmable Transversal Filter (PTF) which will be discussed in Section 2.2.

2.2 The ACT Programmable Transversal Filter (PTF)

The PTF is a 128-tap digitally controllable Finite Impulse Response (FIR) filter that is designed for use in signal equalization, narrowband interference cancelling, and waveform generation. The ACT PTF processes analog signals much like the digital microprocessor processes data and it provides control over the center frequency, bandwidth, gain, and phase of the FIR filter. Using the tapped delay line capability of ACT, the PTF can parallel process hundreds of signal samples at a rate of 360 MHz. It achieves this level of performance by storing signals as quantities of charge within a buried channel on a GaAs substrate. The ACT architecture can perform the fundamental signal processing function of multiply-and-accumulate (MAC) more than 45 billion times a second. The 45 billion MACs/s rate is derived from multiplying the sampling rate of 360 MHz by the number (128) of delay-line taps. The ACT's 128 programmable signal taps are spaced by 5.6 nanoseconds along an ACT delay line operating at 360 MHz. Each tap can be adjusted using 5-bit sign-magnitude tap weighting circuit which is integrated onto the ACT chip and the outputs of all the taps are summed together to form the output signal. Tap weights are programmed using an external computer or a controller. The programming of the taps is accomplished through the parallel port of IBM-compatible personal computer. W.A.V.E.¹ data acquisition and analysis software can also be used to program the tap coefficients where special commands within W.A.V.E. allows users to load arbitrary tap weight vectors. Throughout this report, Turbo-C software package was used to implement the specific test procedures to program the ACT taps weights.

¹W.A.V.E. software is a product of Electronics Decision Incorporated.

The characteristics and performance parameters of the ACT PTF module is summarized in Table I.

TABLE I

Parameter	Specification	Parameter	Specification
Sampling rate	360 MHz	Maximum input level	-10 dBm
Number of taps	128	Power dissipation	< 3 W
Tap weighting	Bipolar; 5 bits	Insertion loss	25 dB
Tap spacing	5.6 nsec	Dynamic range	40 dB
Programming time	1 usec	No. of Channels	1

2.3 Adaptive Interference Canceller

The interference canceller is a closed loop adaptive filter that is designed to reduce the level of narrowband interference in wideband systems. It identifies the strongest interfering signal, precisely determines its frequency and produces a cancelling signal at that frequency to reduce the interference (by introducing a notch at that frequency) with minimum perturbation of the wideband signal. Wideband systems benefit from this function because it allows them to operate in dense electromagnetic signal or jamming environment with less transmit power.

The interference canceller uses an ACT PTF. In this report the cancellation is accomplished using the Linear Random Search (LRS) adaptive algorithm implemented in Turbo-C software package. Algorithms such as Recursive Least Squares (RLS), Sequential Regression (SER), Least Mean Square (LMS), and frequency domain

algorithms which utilize the internal tap updates are not realizable because the internal taps of the ACT are inaccessible.

The following diagram, Figure 1, illustrates a Programmable Transversal Filter in ACT technology.

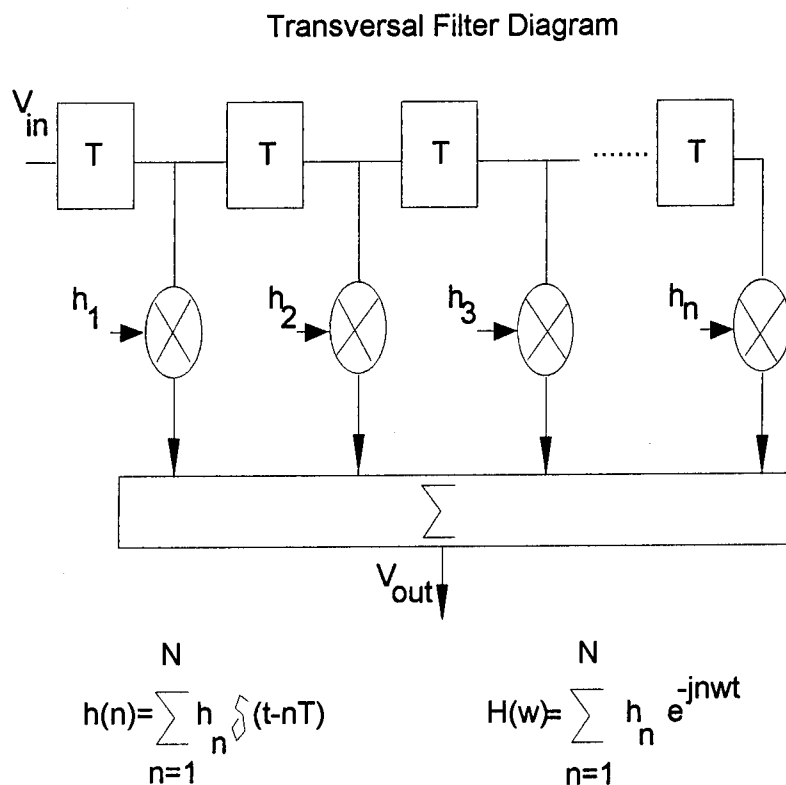

Figure 1

To summarize the characteristics of a programmable transversal filter, its four functions are defined as follows:

- * **Delay:** The tapped delay line samples and delays the input signal.
- * **Multiply:** Digitally controlled attenuators multiply each output by its coefficient.
- * **Accumulate:** The summing bus accumulates the weighted tap outputs to produce the composite output signal.
- * **Control:** Tap coefficients are programmed to define the desired response.

3.1 COMPUTER SIMULATION OF THE LRS ALGORITHM:

A computer modeling program is written in MATLAB (MATrix LABoratory) which simulates the Linear Random Search (LRS) algorithm in order to compare with the results found experimentally. This simulation carefully considers all the aspects of the experimental testing of the Acoustic Charge Transport (ACT) device. The simulation models a CW jammer as a narrowband interference tone within the frequency range of the ACT (e.g., 50 MHz). Since the tap-to-tap spacing of the ACT is 5.6 nsecs, the sampling frequency of approximately 178 MHz is used for this simulation. Next an initial set of weights (\mathbf{W}_k) is loaded into the program which constitutes the initial transfer function of the system. These weights are designed using the FIR2 function of MATLAB and they are the unit pulse response of a bandpass filter with length 128 and normalized center frequency. A complete description of using FIR2 filter design function can be found in the signal processing toolbox manual of MATLAB. Uniform quantization is taking place in this simulation where each tap weighting is 5 bits and bipolar. This procedure is performed within the simulation to accurately model the ACT Programmable Transversal Filter (PTF). Output signal is formed by multiplying the Fast Fourier Transformation (FFT) of the input signal and the initial transfer function of the system, and then the output power is measured ($\xi(\mathbf{W}_k)$). Next a small random change \mathbf{U}_k is tentatively added to the initial weight vector \mathbf{W}_k at the beginning of each iteration, therefore the perturbed nominal tap weight vector yields the tentative tap weight vector. Again the corresponding output power is measured ($\xi(\mathbf{W}_k + \mathbf{U}_k)$) and the power difference between the two measured output powers ($\xi(\mathbf{W}_k) - \xi(\mathbf{W}_k + \mathbf{U}_k)$) is used for permanent weight vector modification from \mathbf{W}_k to \mathbf{W}_{k+1} , proportional to the product of the change in performance and the initial tentative change [2]. This process is shown as:

$$\mathbf{W}_{k+1} = \mathbf{W}_k + \beta [\xi(\mathbf{W}_k) - \xi(\mathbf{W}_k + \mathbf{U}_k)] \mathbf{U}_k \quad (1)$$

Several graphs in the simulation demonstrate the changes (e.g., cancellation depth, convergence factor and so on) that are taking place as the simulation progresses.

3.2 Linear Random Search (LRS) algorithm implementation:

A Hewlett-Packard (HP 8640B) RF signal generator supplies the interference signal to the ACT device. The power output of the ACT is measured using a Giga-Tronics 80301 power sensor covering the range of 10MHz through 18 GHz and a Giga-Tronics 8542 power meter. An analog output jack on the power meter yields a DC signal whose amplitude is proportional to the power meter reading. This signal is sampled by the data acquisition unit, a National Instruments AT-MIO-16F-5, which is calibrated to give the power meter reading in dBm. With the power meter set to read in dBm, the DC signal from the analog output jack is proportional to the power meter reading and is continuous over a wide range of power values. AI_VRead function of National Instrument Data Acquisition (NIDAQ) is used to read an analog input channel (channels 0 through 7) which initiates an A/D conversion on an analog input channel and returns the result scaled to a voltage in units of volts.

Based on the measured power meter readings, the LRS algorithm gives the tentative and final weights. These ACT tap weights are set via the computer controller, which is a IBM-compatible computer.

A Hewlett-Packard (HP8568A) spectrum analyzer and a scalar network analyzer (HP8757A) were used to observe the course of changes taking place within the evaluation of the ACT device.

The following diagram, Figure 2, depicts the ACT device test setup:

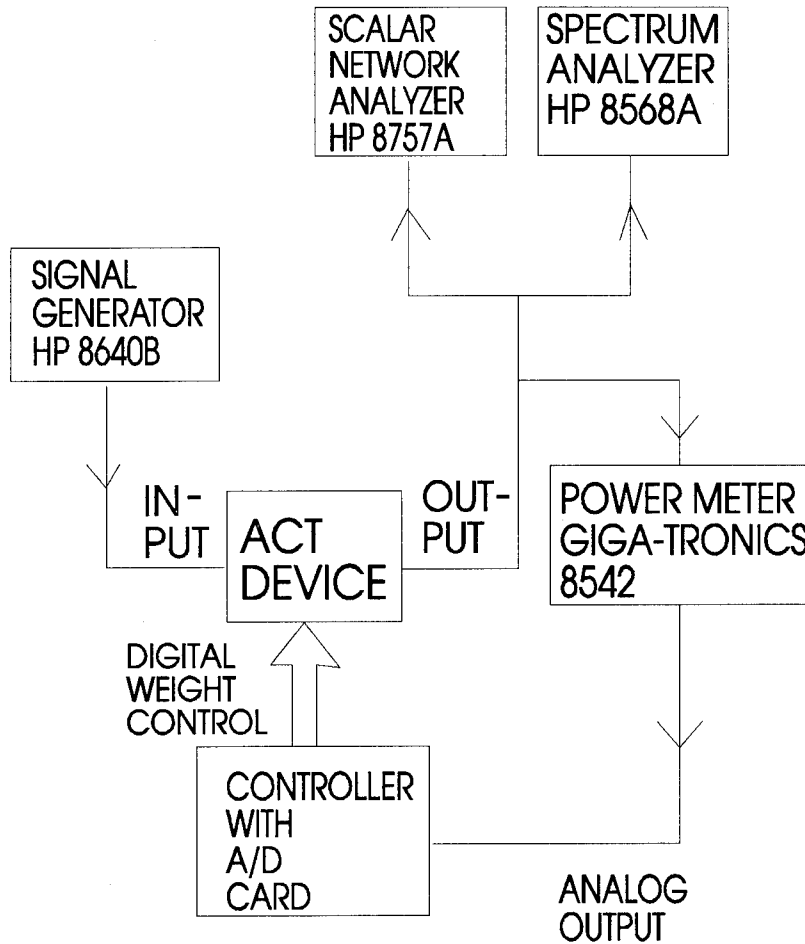

ACT TEST SETUP

Figure 2

It takes minimum of 1μ second to load a set of tap weights into the ACT by means of the computer controller. As the power levels change, at the input of the power meter, the power meter needs a finite amount of time to "settle down" and give accurate readings. There exist some fluctuations in the DC output of the power meter because of this rapid readout. Therefore this problem is compensated by introducing a delay in the power meter reading within the program written for the LRS algorithm. The delay term is a user specified quantity which determines the amount of "sleep-time" that gives the

power meter a chance to "settle down". A typical value for the "sleep time" is between 0.5 to 1 second.

The LRS algorithm is implemented in the "C" programming language. At the beginning of the program some of the variables should be specified by the user. These parameters will determine the gain constant, sleep time, number of iteration, number of filter taps, normalization and the source of the initial tap weight vector.

The exact procedure of the LRS adaptive algorithm is as follows: tap weights are initially set to some nominal value \mathbf{W}_k , by specifying the name of the file containing the desired starting weights, and the corresponding output power $\xi(\mathbf{W}_k)$ is evaluated (ACT output power). Then at k^{th} iteration, small random change \mathbf{U}_k is added to the weight vector \mathbf{W}_k at the beginning of each iteration, therefore the perturbed nominal tap weight vector yields the tentative tap weight vector $\mathbf{W}_k + \mathbf{U}_k$. The corresponding change in performance is then examined, which in this case again is the measured ACT output power $\xi(\mathbf{W}_k + \mathbf{U}_k)$. A permanent weight vector modification, from \mathbf{W}_k to \mathbf{W}_{k+1} , proportional to the product of the change in performance and the initial change, is then made. This process is algebraically represented in equation (1).

The constant term β can be expressed as μ/σ^2 , where it affects the stability and rate of convergence. In selecting the convergence weight factor μ , it should be emphasized that the larger values give faster convergence but less accuracy, while smaller values give slower convergence but higher accuracy. In general, the range of μ is:
 $1/\lambda_{\max} > \mu > 0$, where λ_{\max} is the largest eigenvalue of the autocorrelation matrix (\mathbf{R}) of the input vector. The constant term μ can be approximated as follows:

$$1/[(L+1)(\text{signal power})] > \mu > 0 \quad (2)$$

where L is the filter length.

The power ξ in equation (2) is specified in watts and not in dBm. This power meter measurement, which is read by the data acquisition unit in dBm is then converted to watts, using the following relationship:

$$\xi(\text{watts}) = 10^{-3} \cdot 10^{\xi(\text{dBm})/10} \quad (3)$$

The values used for $\xi(W_k)$ and $\xi(W_k+U_k)$ in equation (2), are obtained from an average of the power meter readings taken over L samples, where L is the filter length.

Since the ACT uses a fixed-point signed-magnitude number representation [1], some precautions should be taken to prevent the internal signal levels from exceeding the dynamic range of the device. Alternately, if the internal signal levels are too low, the output signal may yield a poor signal-to-noise ratio. Thus, as a precaution against overflow, when the weights are formed, a check is made to see whether any of the tap weights is greater than one in absolute value; these weights are automatically clipped to have an amplitude of unity, maintaining their original sign, before being set by the controller.

The program allows the user to choose the scaling option in which all the tap weights are divided by a positive scale factor equal to the magnitude of the tap weight with the largest absolute value before being set by the controller. This is done to increase the size of the tap weight values and hence improve the signal-to-noise ratio of the ACT output signal. Note that if the scaling option is chosen, the built-in clipping feature has no effect.

Because the output of the ACT could fall outside the dynamic range of the power meter, special consideration has to be given in choosing the initial tap weights. The initial tap weights are chosen primarily on their ability to bring the ACT output power up to a more acceptable level. This often means using the designed filter through FIR2 function of the MATLAB as a "starting filter".

4.1 Results of the computer modeling and experimental analyses:

The ACT Programmable Transversal Filter (PTF) employs 128 signal taps spaced by 5.6 nanoseconds along an ACT delay line operating at 360MHz. Each tap can be adjusted using a 5-bit sign-magnitude tap weighting circuit which is integrated onto the ACT and outputs of all taps are summed together to form the output signal. Tap weights are programmed using an external computer (controller). The programming of the ACT tap weights is accomplished through the parallel port of the IBM-compatible personal computer using the "C" program written specifically for this experiment. Two other "C" programs are also written which can be used to load the ACT taps with a 128 tap filter or clear the ACT taps with a specific set of tap weights. The two programs are "LOADACT" and "CLACT" respectively. Another way of loading the ACT taps is through the W.A.V.E. data acquisition and analysis software which was specifically created for the ACT device. A special command within W.A.V.E. package allows the user to load arbitrary tap weight vectors.

The response of the module is measured and displayed on both network and spectrum analyzers. When a significant notch (>15 dB) is achieved in the system transfer function or when the system is converged, the final system transfer function of network analyzer and the final system output of spectrum analyzer are transferred to different files via the IEEE-488 (GPIB) interface bus using the two programs written in the HP Instrumental BASIC (HPIB) environment. These files are saved as data files and they are used for plotting purposes.

Experimentally, CW (Narrowband) interference is applied to the system at three frequencies; 30, 50 and 60 MHz, with power levels of -35 dBm. The initial filter tap coefficients are identical for all cases, where all the tap weights are equal to zero. With all zeros tap weight vector, the response exhibits many local notches and narrow dips, but one of which appears to fall exactly at the 30, 50 and 60 MHz with considerable depth.

The objective is then to set the PTF taps to provide a narrowband transfer function through the PTF with the correct frequency to create a deep notch filter which corresponds to the input interfering signal. For the adaptive algorithm to work properly, the processors or the filter coefficients must be programmed to optimize their response relative to a specified criterion. This criterion in the Linear Random Search (LRS) algorithm is the output power. The adaptive algorithm, observes the output power at each iteration and with the corresponding changes in the output power, alters the filter coefficients with the right convergence step size to achieve the desired response. The LRS algorithm is thoroughly defined in Section 3.2. The constant term β in equation (1) which is expressed as μ/σ^2 defines the rate of convergence and the system stability. Selecting the convergence weight factor μ can be approximated using equation (2). This gain constant is chosen to be 10^3 by trial and error. The cancellation achieved at all narrowband interfering signal at frequencies 30, 50 and 60 MHz is approximately the same and it measures about 15 dB.

Several frequency and time domain plots are included in this section to illustrate the results of both experimental and modeling work. For all the cases Figure 4.1 depicts the typical initial frequency response of the ACT and Figure 4.2 show the frequency response after 250 iterations. It can be seen from Figure 4.2 that the initial power level of the input signal has been decreased by 15 dB after the algorithm has converged. Figures 4.3, 4.4 and 4.5 show the notch filters that are created in the system transfer functions at 30, 50 and 60 MHz respectively. The dashed line is representative of the initial transfer function and the solid line identifies the final transfer function. The cancellations measure about 15 dB at the exact interfering frequencies, which are equivalent to the power level reductions of the initial input signals into the ACT. Figure 4.6 illustrates the typical output power of the system versus the iteration number. This figure is obtained for the case of 60 MHz input interference. As it can be seen from Figure 4.6, the system

approximately converges by the 75th iteration. Same results apply to the cases of 30 and 50 MHz.

The outcome of computer simulation is in accordance with the results obtained in the experimental analysis. Figure 4.7 illustrates the infinite precision (unquantized) and 5-bit sign-magnitude tap weighting (quantized) of initial impulse response of the system. The quantization is uniform and each sample value of the impulse response is approximated with a quantized pulse. The approximation of the true impulse response of the system will result in an error no larger than half the step size between quantization levels, called the quantile interval. The quantile interval for this simulation is $1/32$, therefore degradation of the signal due to quantization is limited to $1/64$.

Next, two interfering signals at 50 MHz and 60 MHz with individual power levels of -7 dB are considered as the input to the system. Figure 4.8 shows both the initial transfer function (dotted line) and the final transfer function (solid line) after the algorithm has converged. It can be seen from Figure 4.8 that some local notches and narrow dips again appear in this plot, but 15 dB of cancellation has been achieved at the interfering 50 MHz input signal. The adaptive algorithm behaves similarly for the case of the interfering signal appearing at 60 MHz and about 15 dB of cancellation is again obtained. Figure 4.9 depicts a typical curve of output power versus the number of iterations. In the case of computer modeling, the system converges after 1600 iterations.

The simulation program without the use of the quantization gives similar cancellation at the interfering signal. Figure 4.10 represents the cancellation obtained with approximately 15 dB of nulling and the power versus the iteration number is shown in Figure 4.11, where the system has converged after 10000 iterations.

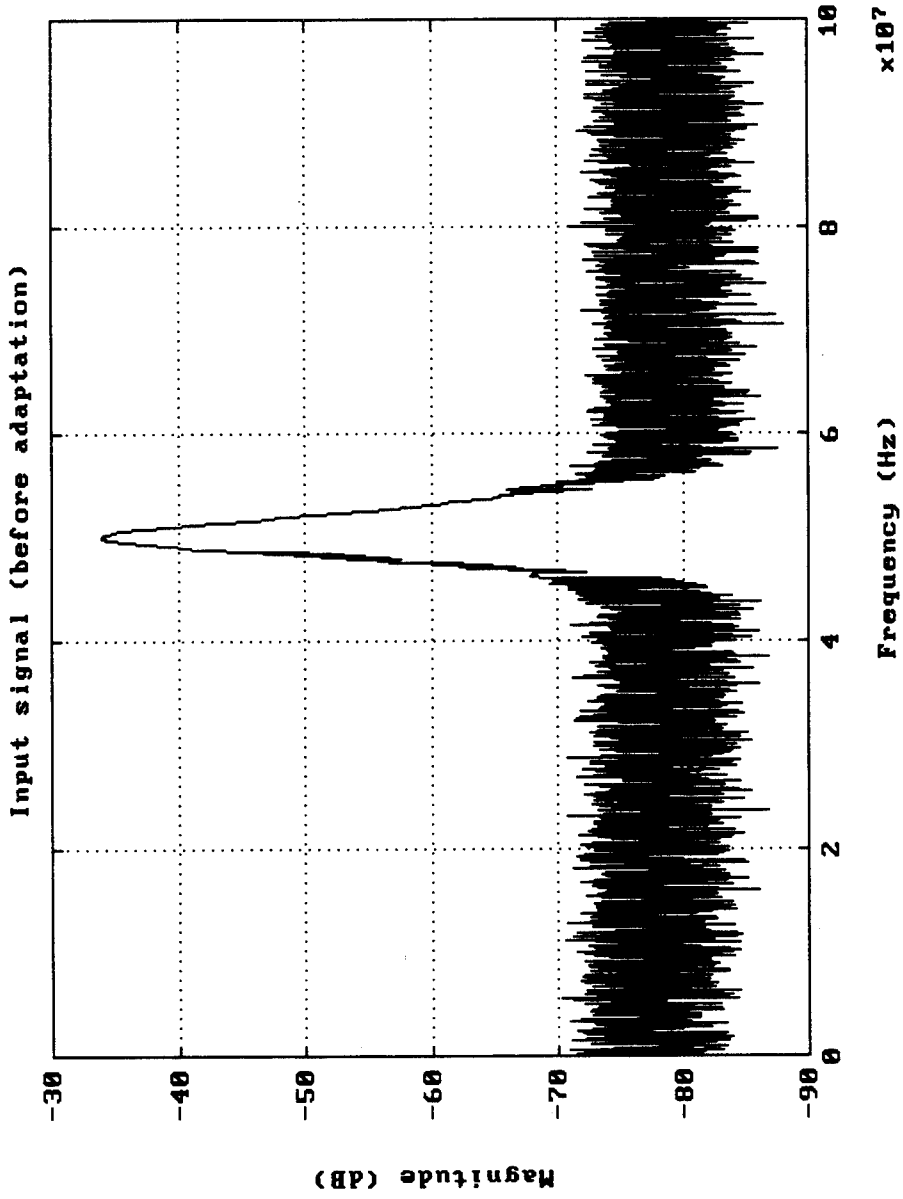

Figure 4.1

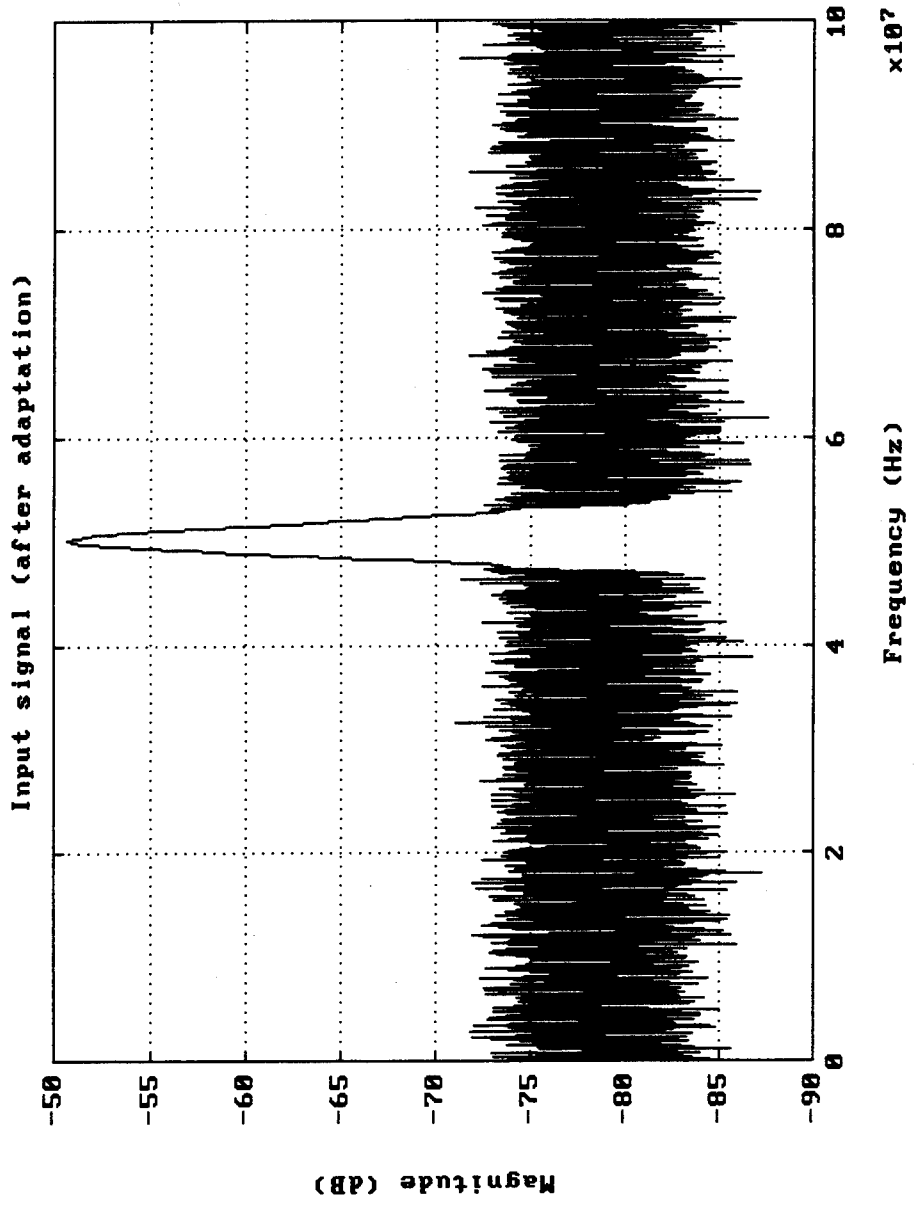

Figure 4.2

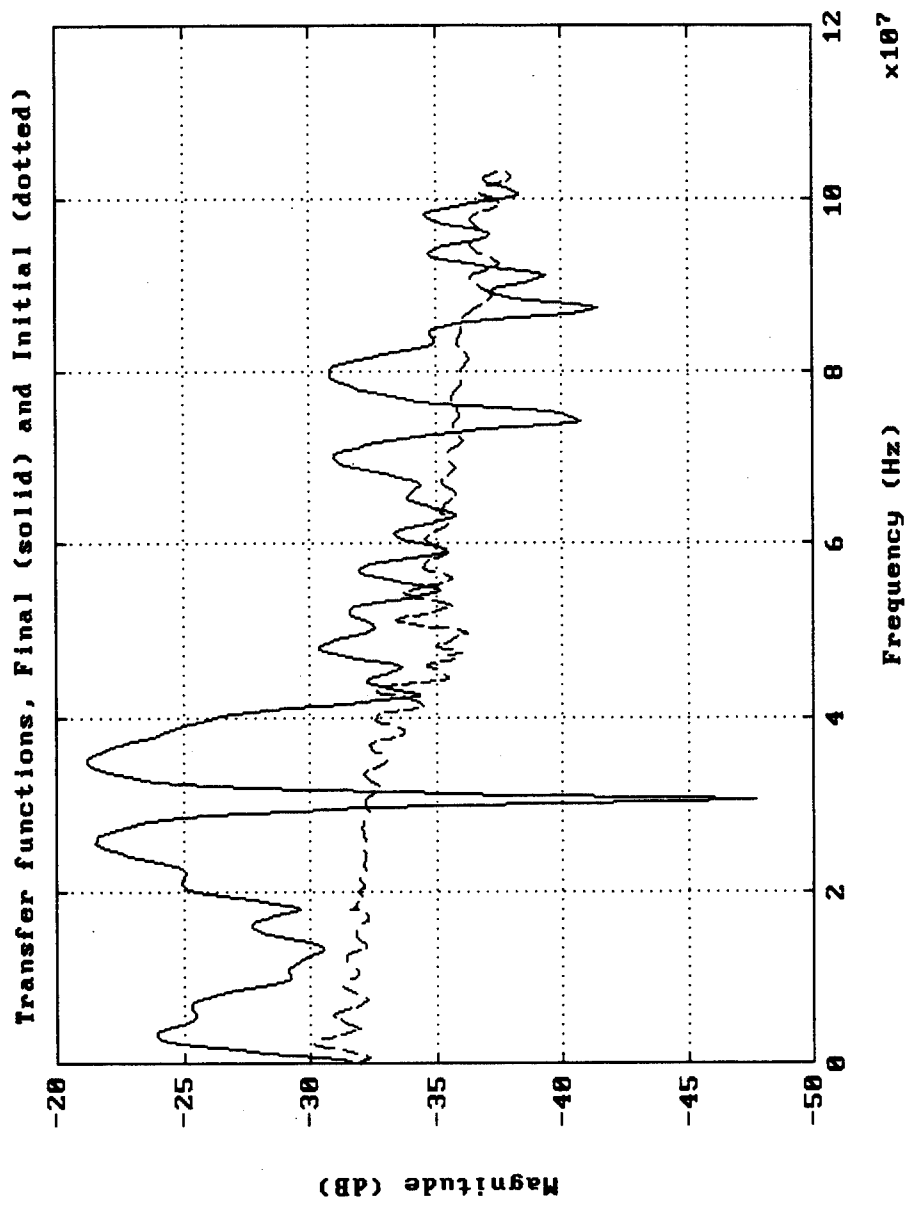

Figure 4.3

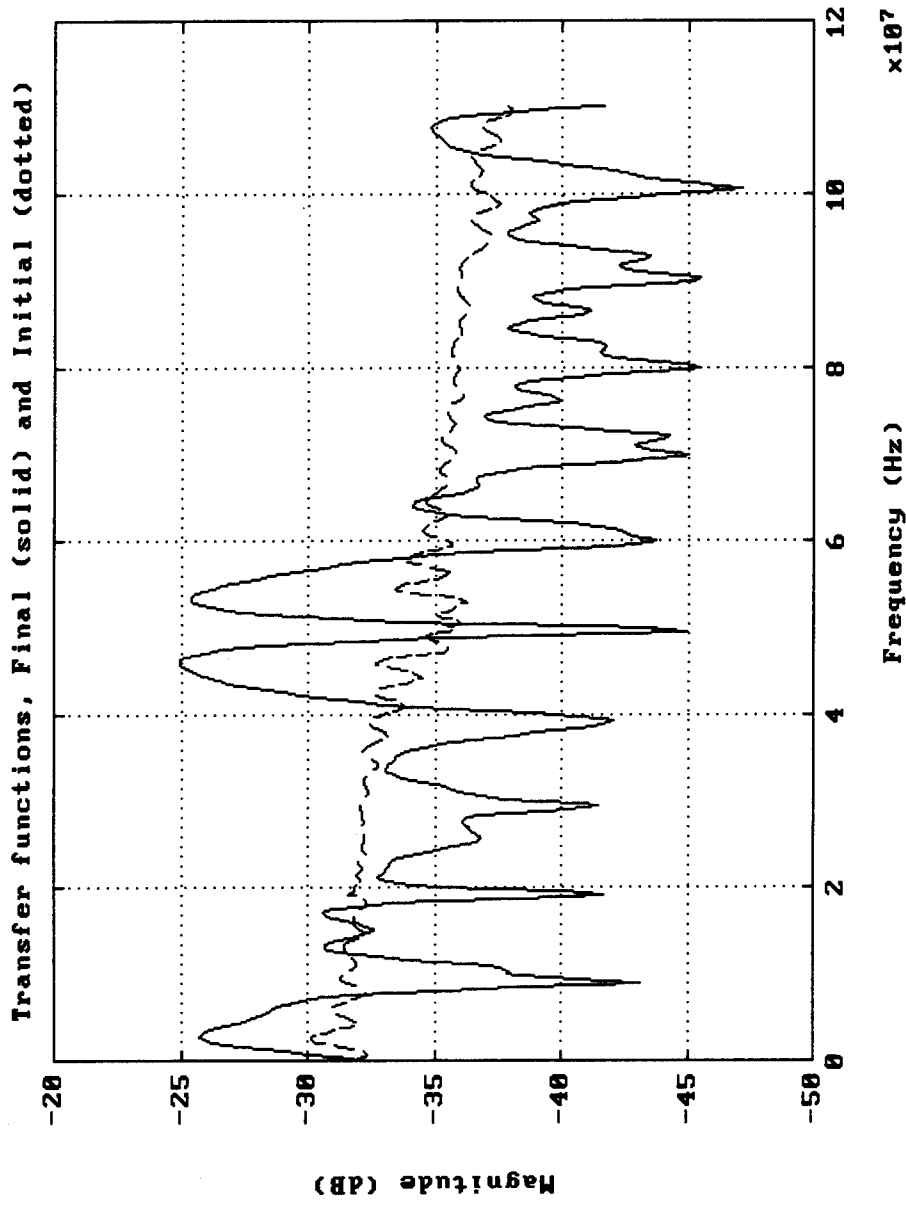

Figure 4.4

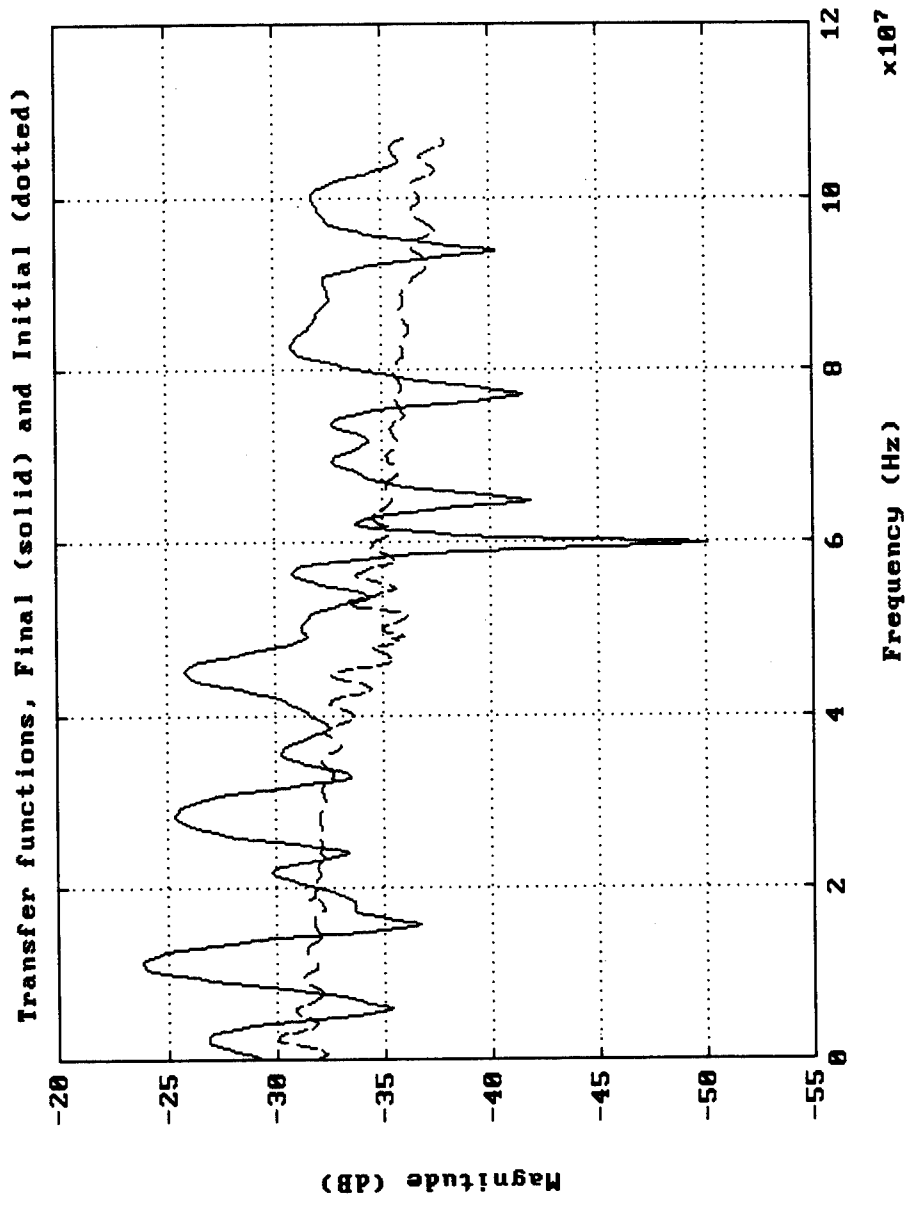

Figure 4.5

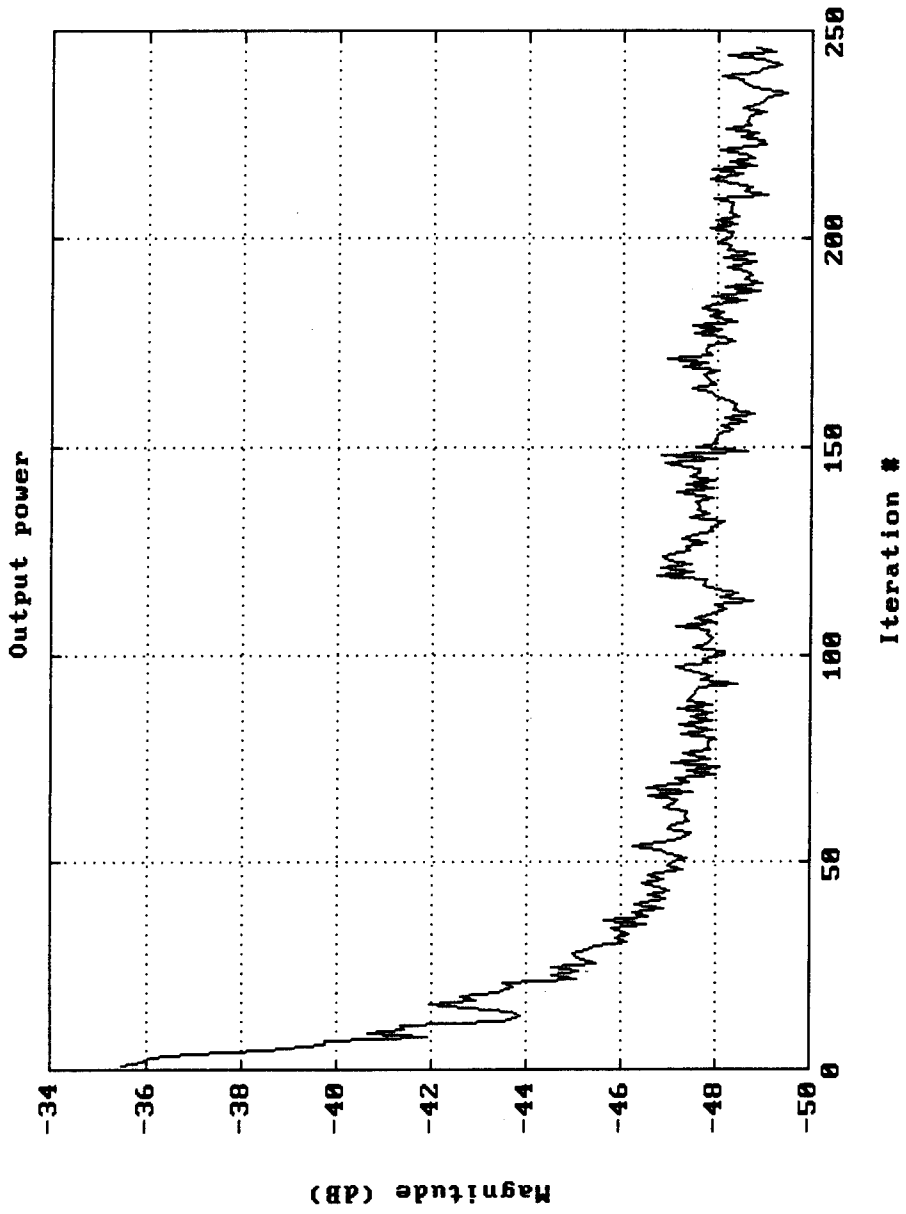

Figure 4.6

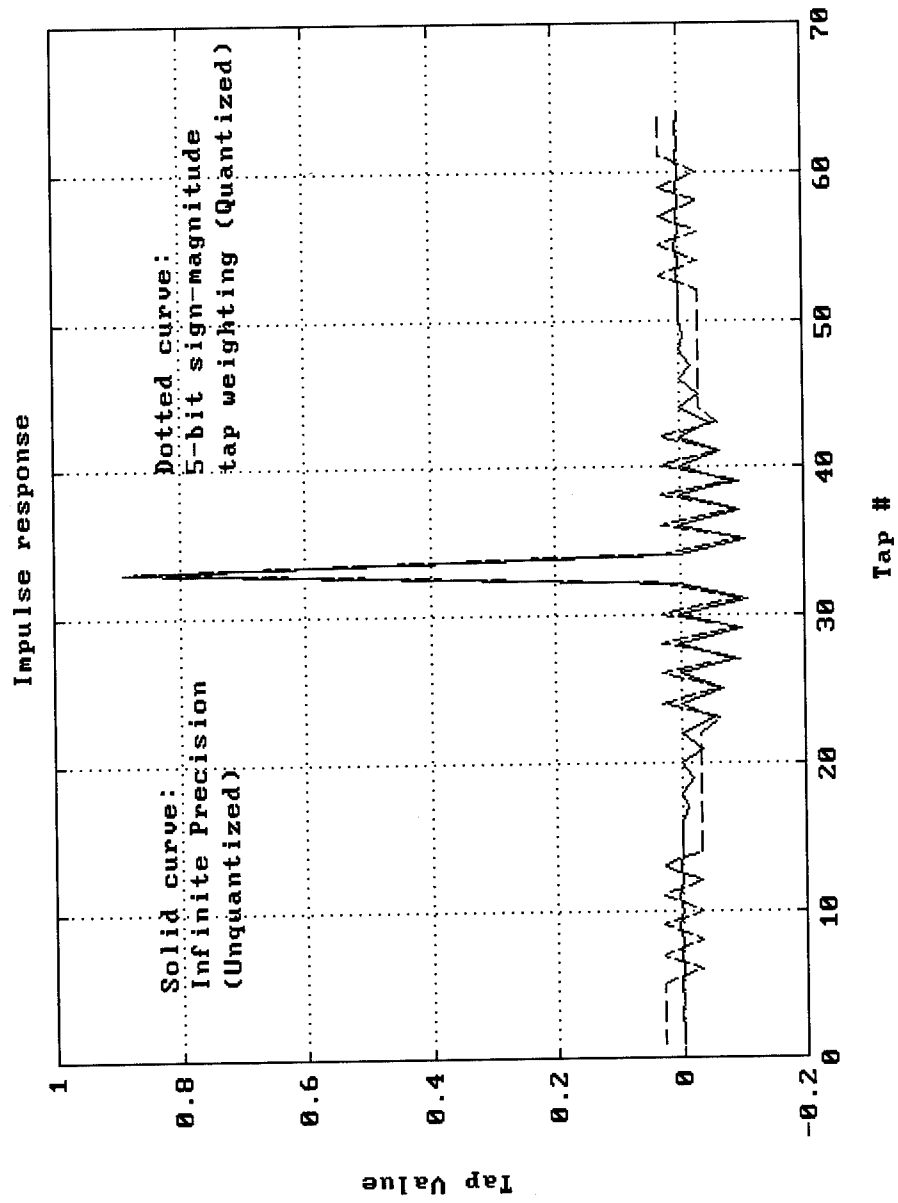

Figure 4.7

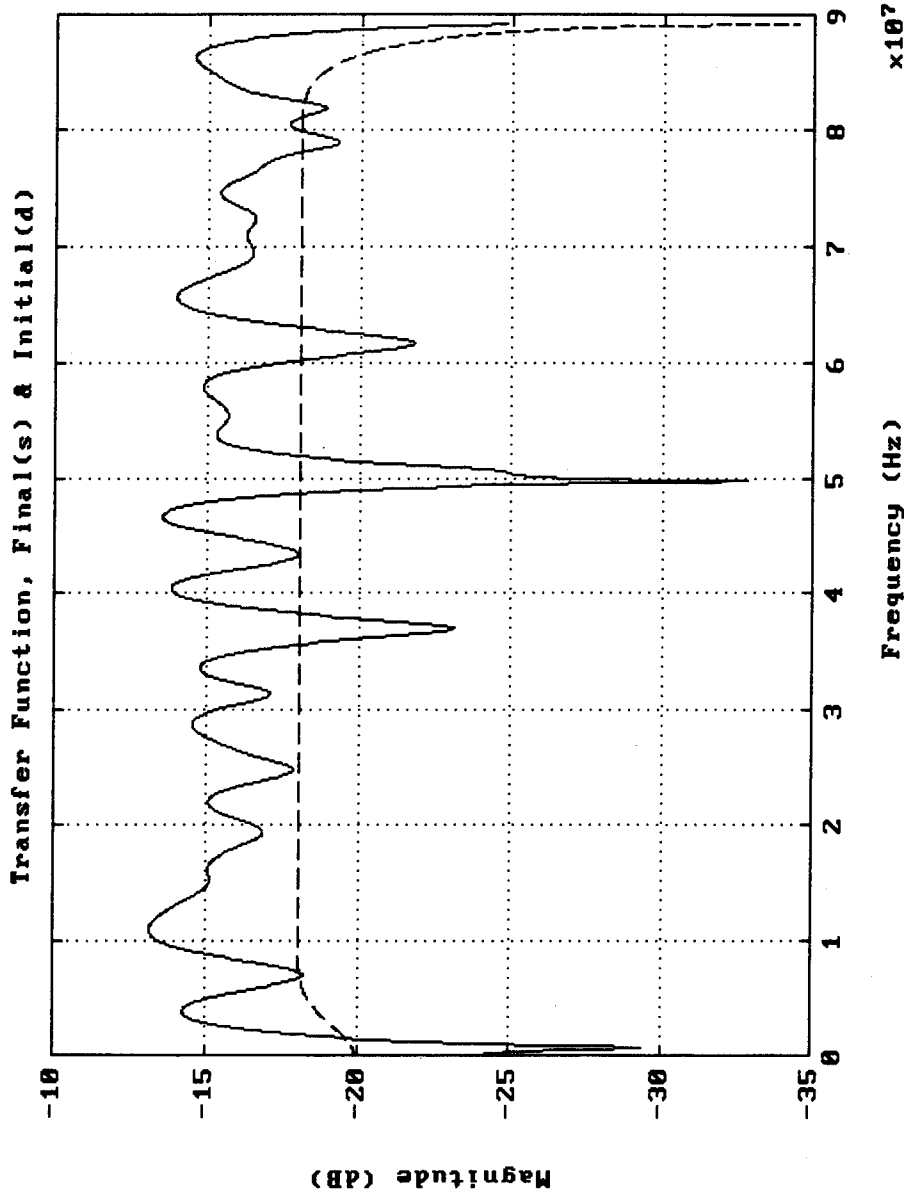

Figure 4.8

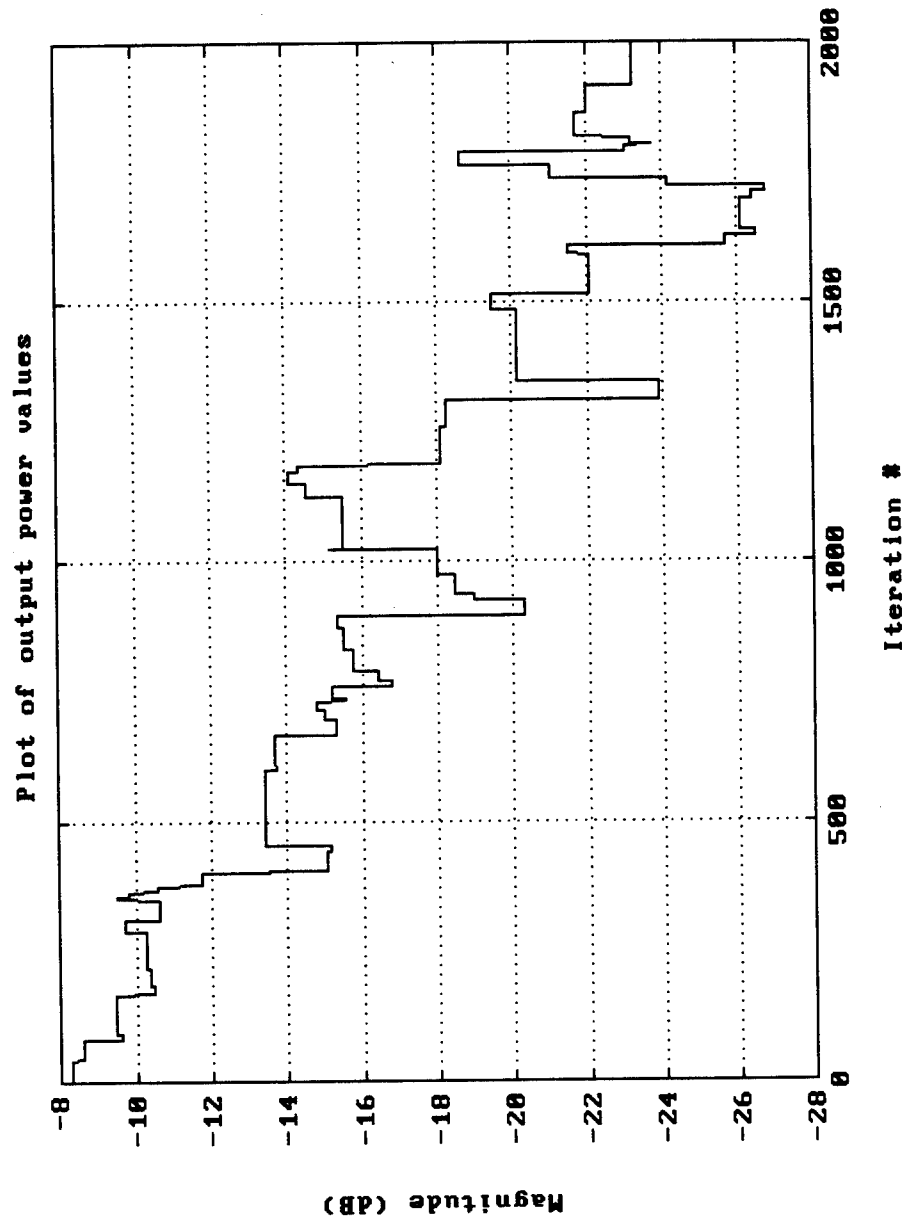

Figure 4.9

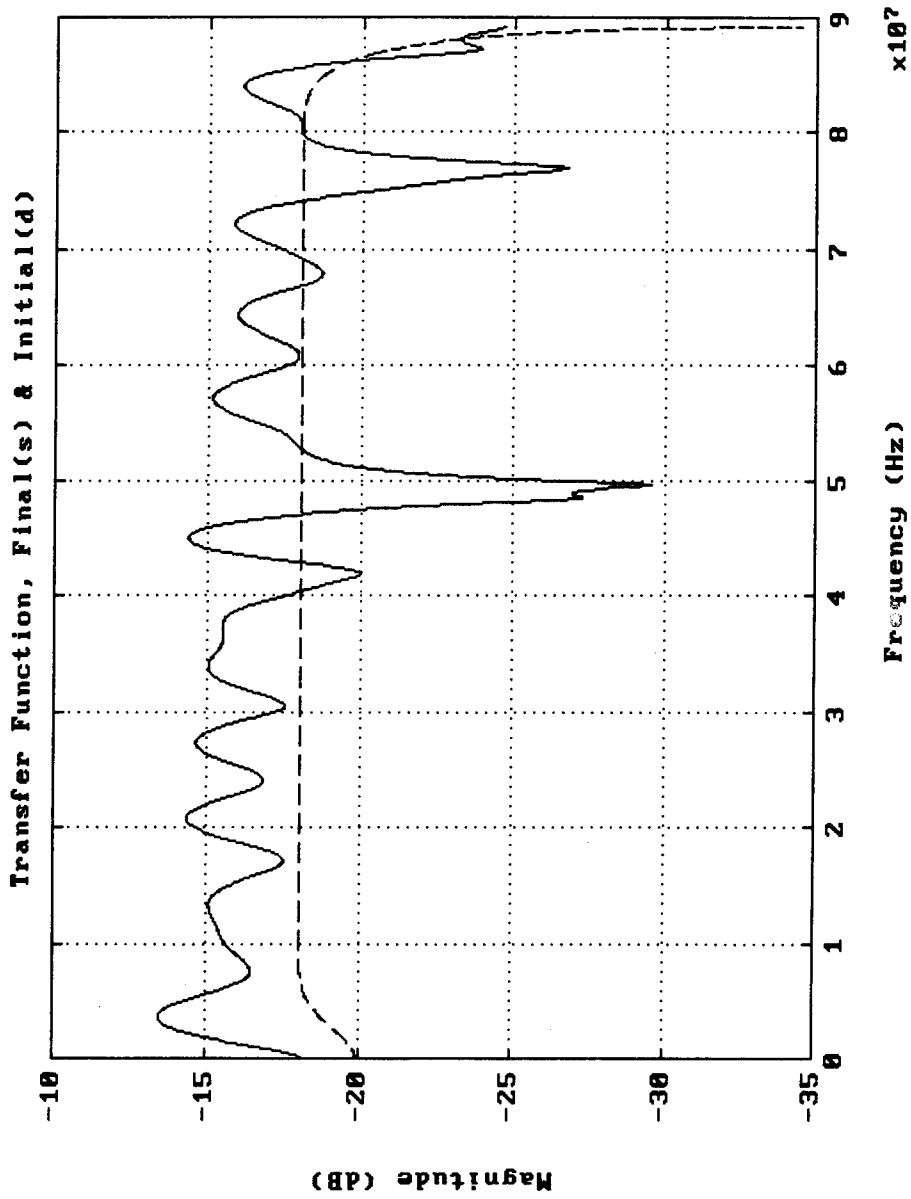

Figure 4.10

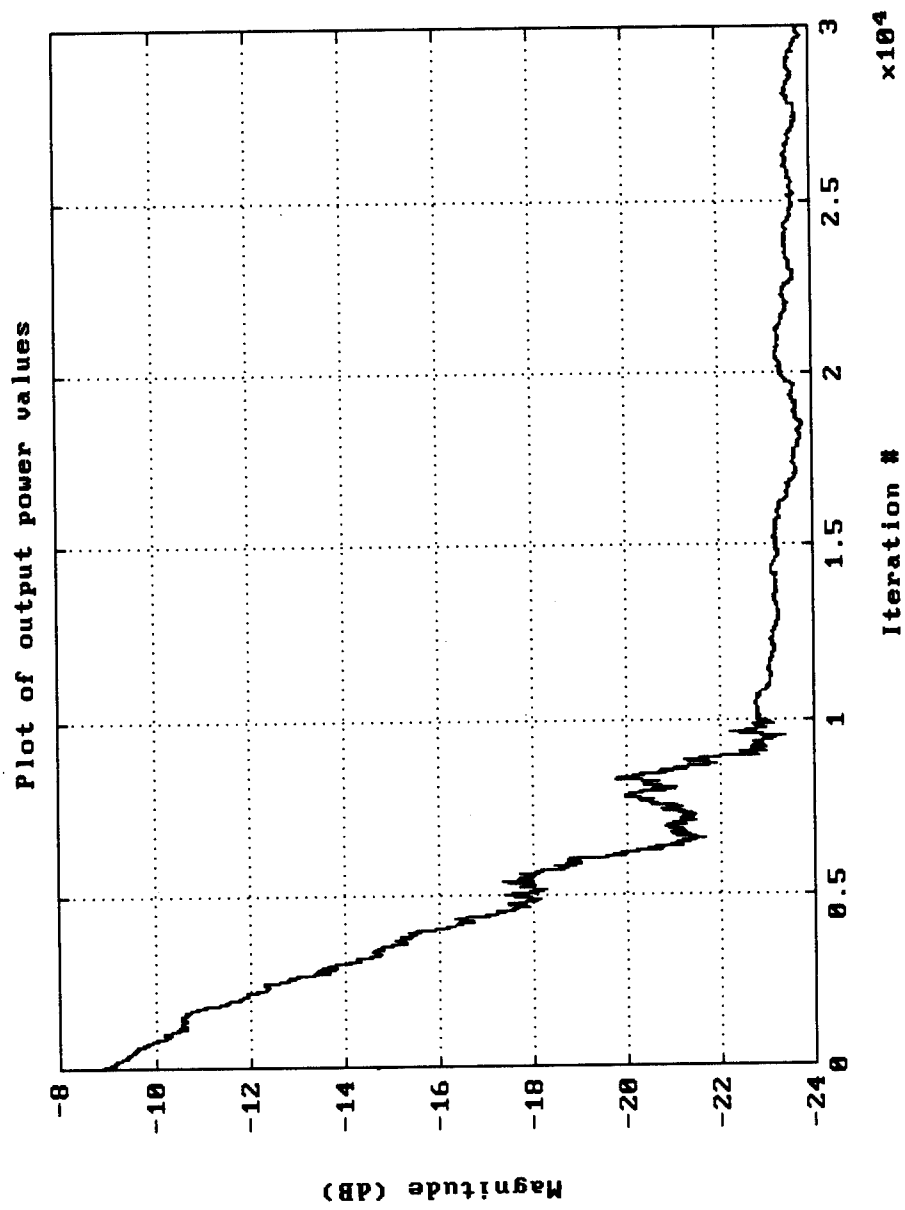

Figure 4.11

5.0 CONCLUSION

In this project, the LRS algorithm was implemented in the ACT device as an adaptive filtering algorithm. Both the experimental and simulation results were compared to each other and the results were in agreement. The amount of rejection or the depth of the null at the interfering input signals was measured to be approximately equal in both the experimental and modeling analyses. It was found that a significantly fewer number of iterations is required for adaptation experimentally, when direct power measurements are utilized, compared to that required by computer simulation when the power is estimated from L samples of the output signal.

Tap resolution (# of bits per tap weight) is an important factor in interference cancellation. In this experiment each filter tap was adjusted using 5-bit sign-magnitude tap weighting and maximum achievable cancellation was found to be 15 dB. Deeper cancellation would be achieved if the tap resolution was higher since dynamic range of the ACT device is 40 dB [1]. Tap precision variation is not feasible in this experiment, since the tap weighting is fixed at 5-bit sign-magnitude.

An improvement in the system performance might be achieved if other schemes of adaptive algorithms with accessible internal taps could be used instead of the LRS algorithm. If the internal taps of the ACT were accessible, then algorithms such as Least Mean Square (LMS) could have been used to test for random locations in the performance space rather than testing for random directions in space. Testing for random locations in space makes the algorithm more efficient and faster to converge.

6.0 REFERENCES:

1. W. Hunsinger, R. Kansy and M. Hoskins, "Analog-Digital Array Processor, ACT Technology Development" RADC-TR-87-296, Vol. I, Jan. 1988, pp. 15-25, B122797.
2. B. Widrow and S.D. Stearns, "Adaptive Signal Processing", Englewood Cliffs, NJ, Prentice-Hall, 1985.

***MISSION
OF
ROME LABORATORY***

Mission. The mission of Rome Laboratory is to advance the science and technologies of command, control, communications and intelligence and to transition them into systems to meet customer needs. To achieve this, Rome Lab:

- a. Conducts vigorous research, development and test programs in all applicable technologies;
- b. Transitions technology to current and future systems to improve operational capability, readiness, and supportability;
- c. Provides a full range of technical support to Air Force Materiel Command product centers and other Air Force organizations;
- d. Promotes transfer of technology to the private sector;
- e. Maintains leading edge technological expertise in the areas of surveillance, communications, command and control, intelligence, reliability science, electro-magnetic technology, photonics, signal processing, and computational science.

The thrust areas of technical competence include: Surveillance, Communications, Command and Control, Intelligence, Signal Processing, Computer Science and Technology, Electromagnetic Technology, Photonics and Reliability Sciences.

