

Report No. CG-D-27-94

Directional Stability Tests of a 30 Degree Deadrise Prismatic Planing Hull

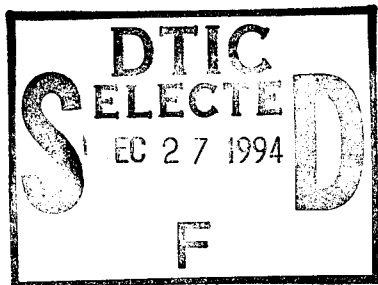

P. Ward Brown and Walter E. Klosinski

Davidson Laboratory
Stevens Institute of Technology
Castle Point Station
Hoboken, NJ 07030



FINAL REPORT
DECEMBER 1994

This document has been approved
for public release and sale; its
distribution is unlimited.

This document is available to the U.S. public through the
National Technical Information Service, Springfield, Virginia 22161

Prepared for:

U.S. Coast Guard
Research and Development Center
1082 Shennecossett Road
Groton, Connecticut 06340-6096

and

U.S. Department Of Transportation
United States Coast Guard
Office of Engineering, Logistics, and Development
Washington, DC 20593-0001

19941219 029

DTIC COPY

NOTICE

This document is disseminated under the sponsorship of the Department of Transportation in the interest of information exchange. The United States Government assumes no liability for its contents or use thereof.

The United States Government does not endorse products or manufacturers. Trade or manufacturers' names appear herein solely because they are considered essential to the object of this report.

The contents of this report reflect the views of the Coast Guard Research & Development Center. This report does not constitute a standard, specification, or regulation.



D. L. Motherway
D. L. Motherway
Technical Director, Acting
United States Coast Guard
Research & Development Center
1082 Shennecossett Road
Groton, CT 06340-6096

1. Report No. CG-D-27-94		2. Government Accession No.		3. Recipient's Catalog No.	
4. Title and Subtitle Directional Stability Tests of a 30 Degree Deadrise Prismatic Planing Hull				5. Report Date December 1994	
				6. Performing Organization Code	
7. Author(s) P. Ward Brown and Walter E. Klosinski				8. Performing Organization Report No. R&DC 14/92	
9. Performing Organization Name and Address Davidson Laboratory Stevens Institute of Technology Castle Point Station Hoboken, NJ 07030				10. Work Unit No. (TRAIS)	
				11. Contract or Grant No. DTCG23-85-C-20060	
12. Sponsoring Agency Name and Address U.S. Coast Guard Research and Development Center 1082 Shennecossett Road Groton, Connecticut 06340-6096				13. Type of Report and Period Covered Final Report	
				14. Sponsoring Agency Code	
12. Sponsoring Agency Name and Address Department of Transportation U.S. Coast Guard Office of Engineering, Logistics, and Development Washington, D.C. 20593-0001					
15. Supplementary Notes					
16. Abstract This is the second of four reports on research designed to obtain basic hydrodynamic information about planing hulls through the use of captive model tests. The information is to be used for the general study of dynamic stability while underway, course keeping, turning and maneuvering, etc. The models tested were of idealized patrol boats having an LBP of 100 ft., a beam of 20 ft., and a displacement of 100 long tons. The models had prismatic hull forms with 10, 20, and 30 degrees of deadrise. The report presents the results of tests on the 30 degree of deadrise hull. Most of the data is for the unappended hull. Straight course and rotating arm tests were conducted at three speeds [$C_v = 1.5, 3.0, \text{ and } 4.0$], three angular velocities [$L/R = 0, 0.117, \text{ and } 0.234$] and a single beam loading [$C_\Delta = 0.4375$]. The tests covered the following angular parameter ranges. Trim: -2 to 6 degrees, roll: -10 to 20 degrees, and yaw: -15 to 15 degrees. Twin rudders were fitted during the straight course tests at zero degrees of roll and yaw, and three degrees of trim. The effect of rudder deflection from -20 to 20 degrees was investigated. Measurements were made of the drag and side forces, and the roll, pitch, and yaw moments. Draft was recorded. Underwater photographs were taken, and the wetted lengths and areas determined from these photographs. Video recordings were made of all runs. The data are presented in extensive tables, in wind axes and body axes, and in both dimensional and non-dimensional form.					
17. Key Words planing boats prismatic hulls turning tests directional stability			18. Distribution Statement Document is available to the U.S. public through the National Technical Information Service, Springfield, Virginia 22161		
19. Security Classif. (of this report) UNCLASSIFIED		20. SECURITY CLASSIF. (of this page) UNCLASSIFIED		21. No. of Pages	22. Price

METRIC CONVERSION FACTORS

Approximate Conversions to Metric Measures

Symbol	When You Know	Multiply By	To Find	Symbol
LENGTH				
in	inches	* 2.5	centimeters	cm
ft	feet	30	centimeters	cm
yd	yards	0.9	meters	m
mi	miles	1.6	kilometers	km
AREA				
in ²	square inches	6.5	square centimeters	cm ²
ft ²	square feet	0.09	square meters	m ²
yd ²	square yards	0.8	square meters	m ²
mi ²	square miles	2.6	square kilometers	km ²
	acres	0.4	hectares	ha
MASS (WEIGHT)				
oz	ounces	28	grams	g
lb	pounds	0.45	kilograms	kg
	short tons (2000 lb)	0.9	tonnes	t
VOLUME				
tsp	teaspoons	5	milliliters	ml
tbsp	tablespoons	15	milliliters	ml
fl oz	fluid ounces	30	milliliters	ml
c	cups	0.24	liters	l
pt	pints	0.47	liters	l
qt	quarts	0.95	liters	l
gal	gallons	3.8	liters	l
ft ³	cubic feet	0.03	cubic meters	m ³
yd ³	cubic yards	0.76	cubic meters	m ³
TEMPERATURE (EXACT)				
°F	Fahrenheit temperature	5/9 (after subtracting 32)	Celsius temperature	°C

* 1 in = 2.54 (exactly).

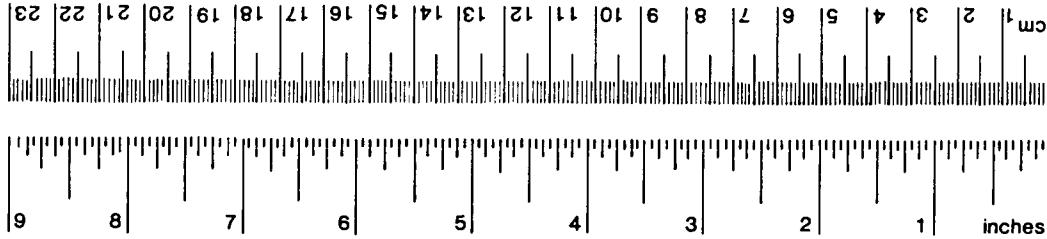

Approximate Conversions from Metric Measures

Symbol	When You Know	Multiply By	To Find	Symbol
LENGTH				
mm	millimeters	0.04	inches	in
cm	centimeters	0.4	inches	in
m	meters	3.3	feet	ft
m	meters	1.1	yards	yd
km	kilometers	0.6	miles	mi
AREA				
cm ²	square centimeters	0.16	square inches	in ²
m ²	square meters	1.2	square yards	yd ²
km ²	square kilometers	0.4	square miles	mi ²
ha	hectares (10,000 m ²)	2.5	acres	
MASS (WEIGHT)				
g	grams	0.035	ounces	oz
kg	kilograms	2.2	pounds	lb
t	tonnes (1000 kg)	1.1	short tons	
VOLUME				
ml	milliliters	0.03	fluid ounces	fl oz
l	liters	0.125	cups	c
l	liters	2.1	pints	pt
l	liters	1.06	quarts	qt
l	liters	0.26	gallons	gal
m ³	cubic meters	35	cubic feet	ft ³
m ³	cubic meters	1.3	cubic yards	yd ³
TEMPERATURE (EXACT)				
°C	Celsius temperature	9/5 (then add 32)	Fahrenheit temperature	°F

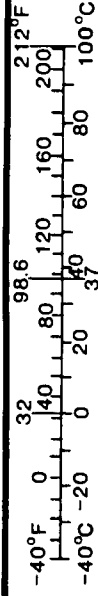

TABLE OF CONTENTS

NOMENCLATURE	vii
INTRODUCTION	1
MODELS	2
APPARATUS AND INSTRUMENTATION	3
TEST PROCEDURE	5
TEST PROGRAM	6
DATA PROCESSING	7
Air Tares	8
Wetted Area	9
RESULTS	10
DISCUSSION OF RESULTS	12
RECOMMENDATIONS	14
REFERENCES	15

FIGURES

FIGURE 1	LINES OF 20° DEADRISE PARENT HULL	16
FIGURE 2	LINES OF 30° DEADRISE MODEL	17
FIGURE 3	PHOTOGRAPH OF 30° DEADRISE MODEL	18
FIGURE 4	PHOTOGRAPH OF 30° DEADRISE MODEL ON ROTATING ARM	19
FIGURE 5	UNDERWATER PHOTOGRAPH OF 30° DEADRISE MODEL	20
FIGURE 6	PHOTOGRAPH OF STRAIGHT COURSE TEST OF 30° DEADRISE MODEL	21
FIGURE 7	PITCH AND ROLL PIVOT BOX	22
FIGURE 8	VARIATION OF STRAIGHT COURSE ROLL STABILITY WITH SPEED	23

TABLES

TABLE 1	TABLE OF MODEL PARTICULARS	24
TABLE 2	RUN DIRECTORY	25
TABLE 3	RUDDER RUN DIRECTORY	41
TABLE 4	WETTED AREA DATA	42
TABLE 5	STABILITY DATA IN WIND AXES WITHOUT AIR TARES	60
TABLE 6	STABILITY DATA IN BODY AXES AT PIVOT	84
TABLE 7	STABILITY DATA IN BODY AXES AT TRANSOM	108
TABLE 8	STABILITY DATA IN BODY AXES AT TRANSOM, NON-DIMENSIONAL	132
TABLE 9	RUDDER STABILITY DATA IN WIND AXES WITHOUT AIR TARES	150
TABLE 10	RUDDER STABILITY DATA IN BODY AXES AT PIVOT	151
TABLE 11	RUDDER STABILITY DATA IN BODY AXES AT TRANSOM	152
TABLE 12	RUDDER STABILITY DATA IN BODY AXES AT TRANSOM, NON-DIMENSIONAL	153

NOMENCLATURE

b	beam at chine, ft
CG	center of gravity
C_v	velocity coefficient, V/\sqrt{gb}
g	acceleration due to gravity, 32.17 fps ²
K	roll moment, lb-ft, see Appendix C
L	length between perpendiculars, ft
L_c	chine wetted length, inches
L_k	keel wetted length, inches
M	pitch moment, lb-ft, see Appendix C
N	yaw moment, lb-ft, see Appendix C
L/b	length-beam ratio
LBP	length between perpendiculars, ft
r'	non-dimensional angular turn rate, L/R
q	dynamic pressure, $\frac{1}{2}\rho V^2$
R	radius of turn of tow point, ft
R	resistance or drag, lb
SKWL	static keel wetted length, ft, see page 10
TD	transom draft, depth of keel at transom below still water level, ft
V	resultant linear velocity, fps
w	specific weight of water, 62.28 lb/cu.ft fresh water at 71.5°F
X	longitudinal force, lb, see Appendix C
Y	lateral force, lb, see Appendix C
Z	vertical force, lb, see Appendix C
β	deadrise angle, degrees
Δ	displacement, lb
δ	rudder deflection, degrees
ϕ	roll angle, degrees, see Appendix C
θ	trim angle, degrees, see Appendix C
ψ	yaw angle, degrees, see Appendix C
ρ	density of water, w/g, 1.9359 slugs/cu.ft at 71.5°F

NACA Planing Coefficients

C_{Δ}	beam loading coefficient, Δ/wb^3
C_K	roll moment coefficient, K/wb^4
C_M	pitch moment coefficient, M/wb^4
C_N	yaw moment coefficient, N/wb^4
C_V	speed coefficient, V/\sqrt{gb}
C_R	resistance coefficient, R/wb^3
C_X	longitudinal force coefficient, X/wb^3
C_Y	lateral force coefficient, Y/wb^3
C_Z	vertical force coefficient, Z/wb^3

Non-dimensional quantities

Forces	Moments
$X' = X/qb^2 = 2 C_X/C_V^2$	$K' = K/qb^3 = 2 C_K/C_V^2$
$Y' = Y/qb^2 = 2 C_Y/C_V^2$	$M' = M/qb^3 = 2 C_M/C_V^2$
$Z' = Z/qb^2 = 2 C_Z/C_V^2$	$N' = N/qb^3 = 2 C_N/C_V^2$

Sign Convention

The sign conventions are discussed in Appendix C and vary with the axes system being used. The sense of some quantities that in this report are invariant under the various transformations are summarized here.

The trim is positive in the bow up sense and is zero when the afterbody keel is horizontal.

The roll is positive in the starboard side down sense and is zero when the craft is upright.

The yaw is positive in the bow to starboard sense and is zero when the longitudinal axis of the boat is aligned with the resultant velocity.

The rudder deflection is positive in the clockwise sense when viewed from above looking along the rudder stock and is zero when the rudder is aligned with the longitudinal axis of the hull.

The heave is the height of the tow point above the still water surface, is positive vertically upward, and is zero when the tow point is at the still water level.

The transom draft (TD) is the depth of the keel at transom below the still water surface, is positive vertically downward, and is zero when the keel at transom is at the still water level.

The resultant velocity is a horizontal vector, positive forward in the stern-to-bow sense, and is zero when the boat is at rest.

Terminology

Wetted area

The wetted area is the principal wetted area of the bottom. The principal wetted area of a planing craft is the pressure surface of the bottom including the area aft of the spray root, between the chines and forward of the transom. It does not include the area covered by the spray sheet nor the side wetting.

The term wetted area is used to emphasize that it is the actual wetted area and not a projected area.

Longitudinal and lateral forces

The longitudinal and lateral forces are defined in Appendix C. Generally these forces are horizontal vectors fixed in the craft. The longitudinal force is parallel to the longitudinal axis of the craft and is positive aft. The lateral force is perpendicular to the longitudinal force and is positive to starboard.

Drag and side-force

The drag and side force are horizontal vectors oriented with respect to the resultant velocity. The drag, which is synonymous with resistance, is a force vector parallel and opposite to the resultant velocity. The side-force acts at right angles to the velocity and is positive to starboard.

INTRODUCTION

The Davidson Laboratory is conducting a series of planing boat studies in support of the U.S. Coast Guard's pursuit of R&D projects which will enable it to evaluate advanced marine vehicles and advanced technologies which enhance the effectiveness of ship resources. The experimental results obtained at the Davidson Laboratory are intended to contribute to a relevant technical base for the evaluation of vessels which are in service and for designs which are being considered for service.

The objective of this research is to obtain basic hydrodynamic information about planing hulls through the use of captive model tests. This information is required for the study of the transverse stability, yaw/roll stability, course keeping, maneuvering and control of planing hulls, and for the study of seakeeping, and the loss of speed in a seaway, of planing hulls. The Coast Guard feels that this information will be of particular value to individuals or institutions that are developing theories or procedures for the numerical determination of the forces and moments exerted on a planing hull that is maneuvering at planing speeds.

The research results presented in this report are concerned with the directional stability characteristics of a prismatic planing hull model with a deadrise angle of 30 degrees. This model is one of a series. The results obtained with two earlier models, having deadrise angles of 10 and 20 degrees, have been reported in Reference 1. The models are idealizations of patrol boats having a LBP of 100 ft, a beam of 20 ft and a displacement of 100 long tons. The results of captive model tests are reported, including both straight course tests and rotating arm tests. The model was tested over ranges of trim, yaw and roll angles at three speeds and one displacement. The effect of rudders on the straight course characteristics of the model was also investigated. This was done to obtain data to determine if the effective hydrodynamic angle of attack was equal to the geometric angle of attack as determined by kinematics. The effects of propellers was not investigated.

Measured quantities included the drag, side-force, and the roll, pitch and yaw moments. The displacement remained constant on the models, which were free to heave. Underwater photographs were taken of the hulls in each condition for the purpose of determining the wetted lengths and wetted areas of the underside of the planing surfaces.

The data are presented in tabular form in both "wind axes" (see Appendix C) and body axes, and in model scale and non-dimensional units. The results from these tests, plus those from Reference 1, form a considerable data base of approximately 3,500 data points and therefore because of the mass of data, and funding limitations, there is little graphical presentation or analytical discussion of the results.

MODELS

The model series was designed at the Davidson Laboratory and approved by the Coast Guard. It is intended to provide for variations in deadrise and bow form. The parent of the model series is a 20 degree deadrise prismatic hull with flat sections and a length-beam ratio of 5. The parent model is shown on Figure 1. It is a 1/26.66-scale model representing a boat with a design waterline length of 100 feet displacing 100 long tons. The 30 degree deadrise hull is shown on Figure 2. Hull characteristics are given in Table 1.

The forebody is fair and representative of bow shapes that may be expected to be found on patrol boats in service at this time. The after 50% of the hull is a pure prismatic form of constant deadrise with vertical sides. The intersection of the forebody with the prismatic afterbody is smooth and fair without abrupt changes in curvature at the transition. The transom is a plane surface normal to the keel. The use of flat and ruled surfaces is designed to provide aid to those interested in developing theories or numerical schemes for predicting the forces and moments on a planing hull that is maneuvering at planing speeds.

The model was built of sugar pine with 3/8 inch wall thickness, glued with a powdered resin, water-resistant glue. Templates were made from the lines drawing and used during model construction. They were fitted to the models so that no light showed between the template and the model. The finish of the models included the application of one coat of Watco penetrating waterproof sealer, five coats of Lenmar varnish with catalyzed hardener rubbed down between coats: the first coat being dry-sanded and all subsequent coats wet-sanded. The bottom of the model was given two white spray coats and finally the entire model was wet-sanded.

The bottom of the model was striped to assist in determining the keel and chine wetted lengths from the underwater pictures. Lines were ruled

along the keel and chine, and tick marks were placed along these lines at one inch intervals. Every fifth line was connected from chine to chine. Tick marks were also placed along the transom at 0.2 beam intervals. A photograph of the painted model is included on Figure 3.

Spray strips were fitted at the model chines running forward from Station 5 to the stem. In order to ensure clean separation of the water from the chine, strips of brass shim stock were also fitted at the chines from Station 5 to the transom. These brass strips extended vertically downward from the model chine by $1/32$ of an inch.

Twin rudders were made and fitted to the model to determine the rudder effectiveness during the straight course tests. As indicated on Figures 1 and 2 the rudders were mounted normal to the bottom with the rudder post at Station 9.25. These are straight taper rudders with the rudder post at 20% of the chord; their particulars are given in Table 1. When the rudder tests were completed, the rudders were removed and the holes for the rudder stocks were sealed.

The model's deck was covered and sealed with clear lucite. An opening was left at Station 5 for attachment to the towing apparatus and to allow access for setting the trim and roll angles. This opening was then sealed by means of a thin rubber collar between the bottom of the balance and the deck. This is shown in the photograph of the model undergoing straight course tests in Figure 6.

APPARATUS AND INSTRUMENTATION

A pitch and roll pivot box, with provision for setting and locking the trim and roll angles, was mounted in the model. This pivot box is shown on Figure 7. For all of these tests the model was free to heave but fixed in trim, roll and yaw. The pitch axis was located 22.5 inches forward of the transom and 4.15 inches above the keel. The roll axis was parallel to and 4.15 inches above the keel. These axes are shown on Figures 1 and 2. Throughout this report quantities are given either in model scale or in units of beam. Since the beam of the models is 9 inches, the co-ordinates of the tow point are 2.5 beams forward of the transom and 0.46 beams above the keel.

A five-component balance was attached above the pivot box. The longitudinal and lateral forces, and the roll, pitch and yaw moments were

measured in these tests, as indicated in the sketch in Appendix C. A graduated plate on top the balance was included for setting the yaw angle, and the balance rotated with the model in yaw but not in roll or trim. Heave was measured at the pitch pivot, and inclinometers were fitted to assist in setting the trim and roll angles. The five-component balance was attached to twin vertical heave poles in a standard free-to-heave apparatus which included provision for counter-weighting. The free-to-heave apparatus was mounted on a standard testing carriage which was either run on the Tank 3 rail, or attached to the Tank 2 arm. Thus the identical test apparatus was used for both the straight course and rotating arm tests.

The rotating arm tests were carried out in the Davidson Laboratory Tank 2 (75 ft by 75 ft by 4.5 ft deep) at 32 ft and 16 ft radius as shown on Figure 4. The straight course tests (also referred to as infinite radius tests) were performed in Tank 3 (313 ft long by 12 ft wide by 6 ft deep) as shown on Figure 6.

Underwater color photographs were taken of each test run both for the straight course tests in Tank 3 and the rotating arm tests in Tank 2. The view was taken from directly underneath the hull looking upward, and includes the run number and a side view of the hull, as well as the principal pressure area. The photographs are 35 mm color slides and provide an excellent record of the flow conditions about the hulls, as well as showing the wetted lengths. The complete set of color slides are an important supplement to this report. The pictures were taken through a mirror mounted at 45 degrees on the floor of the tank. A camera mounted in a vertical surface-piercing underwater transparent box took pictures of the model in the mirror, as well as a direct view of the model in profile. Flash units on the floor of the tank were used to illuminate the model. The camera and flash were triggered by the passage of the model over the mirror. The rail in Tank 3 is equipped with a counter system which indicates the exact location of the carriage on the overhead rail. Similarly the drive shaft in Tank 2 is equipped with a shaft encoder which indicates the position of the arm. These features make it relatively easy to detect when the model is opposite the camera and to take the photographs when the model is well positioned in the mirror.

An example of an underwater photograph is shown on Figure 5. This shows the model fitted with twin rudders, running on straight course at zero roll and yaw angle. The principal wetted area is clearly delineated as are

many other details of the flow in this underwater picture. For example, it may be noted that at 20 degrees deflection the rudders are completely ventilated. The flow about a planing boat making a turn in a rolled and yawed attitude is much more complicated and the corresponding underwater picture is much more difficult to interpret.

A video camera was mounted above, forward and to port of the model in both Tanks 2 and 3, and a video recording was made of each run. The video tapes and underwater pictures have been sent to the U.S. Coast Guard R&D Center at Avery Point, Connecticut.

TEST PROCEDURE

After the apparatus was setup, the instrumentation was calibrated in place, prior to testing. Known loads and moments were applied to the five component balance, and known displacements to the motion transducers. Combinations of loads and moments were applied to the balance in both the positive and negative sense. The following ranges of calibration were covered:

Drag	30 lb
Side-force	44 lb
Roll moment	25 lb-ft
Pitch moment	25 lb-ft
Yaw moment	44 lb-ft

During calibration the outputs from the transducers were fed to the on-line computer, where a least-squares linear regression analysis was performed. All the calibrations were linear and the rates were stored for use during data collection. The calibrations were checked daily by the application of deadweights applied at a compound angle so as to cause simultaneous deflections in all the transducers. The data acquisition and processing was carried out by the on-line Masscomp computer using a program package designed by Davidson Laboratory known as DAP5. This program digitizes analog signals from the instruments at 250 Hz, and records them on disk in digital form during the test run. After the run the processing programs are called upon to process the data according to user specified parameters. The model was setup for test in the following sequence. With the model at zero

trim, that is with the keel horizontal, and at zero roll, the yaw angle was set by rotating the model in the horizontal plane; then the trim angle was set in the vertical plane; finally the roll angle was set by rolling the model about its longitudinal axis. Zeroes were taken with the model in the air at the yaw, trim, and roll angles. The model was then lowered into the water, and a zero speed run was made to measure the hydrostatic forces and moments acting on the model. The model was then accelerated up to the required speed, data were acquired in the data trap by scanning all channels at 250 Hz, and the results were converted into engineering units and stored in the computer. An underwater photograph was taken at the end of the data trap, the model was decelerated and returned for the next run. Speeds were computed from the time taken to travel through the data trap. Plots of the measured data were made at tankside to monitor the results.

For the straight course tests the data trap was set at 50 ft, that is 13 boat lengths. The rotating arm tests were run in the clockwise direction and the data trap was set up in the fourth quadrant.

Air tare tests were run with the model in the air on straight course and on the rotating arm. The test ranges of speed, radius, and yaw, trim and roll angles were covered to determine the aerodynamic and centrifugal forces and moments. These forces and moments were later subtracted from the total forces and moments measured with the model in the water.

TEST PROGRAM

The displacement for all the tests represented 100 long tons full size: this corresponds to a beam loading of 0.4375, or a model displacement of 11.49 lb. Calm water tests were run on straight course and on the rotating arm at 16 ft and 32 ft radius. The radius of turn is measured in the horizontal plane and refers to the radius at the tow point. The non-dimensional angular velocity, $r' = L/R$, where L is the LBP of the boat, and R is the radius of the turn, provides a convenient means of identifying the non-dimensional radius. Tests on straight course and at radii of 32 ft and 16 ft correspond to non-dimensional angular velocities of 0, 0.117 and 0.234 respectively. The following matrix of conditions was used for the tests of each model:

Test type	<u>Straight Course</u>	<u>Rotating Arm</u>
Model configuration	Unappended	Unappended
Rate of turn, L/R	0	0.117, 0.234
Speed, Cv	0, 1.5, 3, 4	0, 1.5, 3, 4
Trim, degrees	-2, 0, 3, 6	0, 3, 6
Roll, degrees	-10, 0, 10, 20	-10, 0, 10, 20
Yaw, degrees	0, 5, 10, 15	-15, -10, -5, 0, 5, 10, 15

Test type	<u>Straight Course</u>	<u>Rotating Arm</u>
Model configuration	Twin rudders	
Rate of turn	0	
Speed, Cv	1.5, 3, 4	
Trim, degrees	3	
Yaw, degrees	0	
Roll, degrees	0	
Rudder deflection, degrees	-20, -15, -10, -5, 0, 15, 20	

During the tests the water temperature in both tanks was maintained at a value of 71.5°F which was checked twice daily.

DATA PROCESSING

The test data were processed to meet several requirements. These include 1) a tabulation of the "raw" data on a day by day, run by run basis; 2) presentation of the data in a body coordinate system with origin at the intersection of the keel with the transom; and 3) presentation of the body coordinate data in non-dimensional form. There was also a requirement to illustrate the data reduction process, and to present the transformation equations from the balance coordinate system to the body coordinate system. These requirements were met in the following manner. 1) Each run is given a unique sequence number, and therefore a listing of the run numbers and test conditions satisfies the need for a run by run record. This is included in

Appendix B, which is the Chronological Run Directory. The run numbers are assigned sequentially by the computer, and a "run" identifies a data taking event which is not necessarily a run down the tank. Thus in Appendix B some run numbers have the prefix "DZ", which indicates that the data were taken at zero speed, while others are prefaced by "DR", which denotes a run taken for checking purposes. The raw data were taken to be the dimensional model data in "wind axes". The wind axes move with the model, have a horizontal and vertical orientation, and have their origin at the tow point; the x-axis is parallel and opposite to the resultant velocity, the y-axis is positive to starboard, and the z-axis is positive upward. The wind axes and balance measurement axes coincide at zero yaw angle. The data in wind axes including the air tares, are presented in Appendix A, and represent the raw data. 2) The air tares in the wind axes were analyzed and removed from the raw data. The net hydrodynamic forces and moments are presented in model scale dimensional form in Table 5. These data were then transformed to body axes, with origin at the tow point, and tabulated in Table 6. These dimensional data were then transferred to an origin at the intersection of the keel with the transom, as given in Table 7. 3) The body axis data from Table 7 with origin at the keel-transom intersection, were non-dimensionalized and are presented in Table 8.

The various axes systems are described in Appendix C, together with the transformation equations and non-dimensionalizing scheme. Forces are normalized with respect to the product of the dynamic pressure and the square of the beam, while moments are normalized by the product of the dynamic pressure and the cube of the beam. The presentation of the data at various stages, together with the transformation equations, provides a clear audit trail between the raw data and the final results, and illustrates the data reduction process.

Air Tares

The first step in the data processing is to identify and remove the forces and moments due to centrifugal and aerodynamic forces. Since these two forces tend to be parallel to the axes of the wind axis system, all the data were transferred to wind axes. The "air tare" results were plotted and suitable equations identified to represent them. A regression analysis of the

"air tare" data taken with the model in the air was performed, and the equations adopted for the air tare forces and moments are given in Appendix C. Separate analyses were made of the straight course and rotating arm data. As a check on these fits, the air tare results were themselves corrected by subtracting the calculated forces and moments, and examining the residuals. These were sufficiently small to indicate that a satisfactory fit had been obtained. These same equations were then applied to the data obtained with the model in the water.

Wetted Area

The underwater pictures were used to record the wetted area of the hull in both the straight course and rotating arm tests. Due to the attitude of the hull when rolled in a turn, it was necessary to read both the port and starboard wetted chine lengths, as well as the keel wetted length. The general underwater appearance is illustrated in Sketch A:

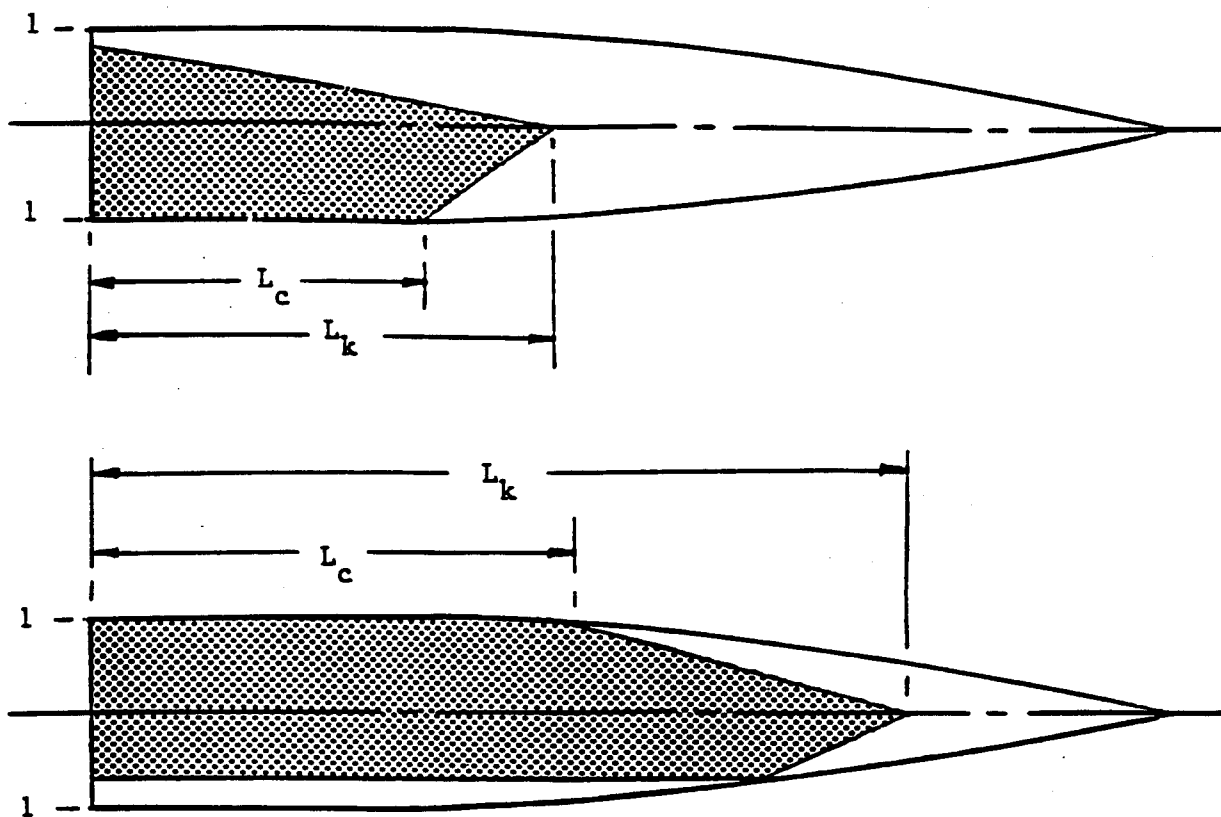

Sketch A - Underwater Wetted Areas

In cases where the chines were dry, because either the stagnation line crossed the transom or the flow separated before reaching the chine, the fraction of the beam at transom that was wetted was recorded. For each run, the wetted areas were calculated from the observed keel and chine wetted lengths, and the transom wetted width, together with the hull girths from chine to chine. In those cases where side wall wetting occurred, the wetted side wall area was not measured. The tabulated wetted areas are actual wetted areas and not vertically projected areas.

The readings from the heave and trim transducers were used to calculate the transom draft (TD) and the "static keel wetted length" (SKWL), which is the keel wetted length without allowing for wave rise. The dynamic keel wetted length from the underwater photographs may be correlated with the SKWL, which provides a means of fairing these data. The transom draft is defined as the draft of the keel at the transom relative to the still water surface. Both TD and SKWL are illustrated in Sketch B. The values of SKWL are included in the wetted area tables, Table 4, and those of TD in Table 5.

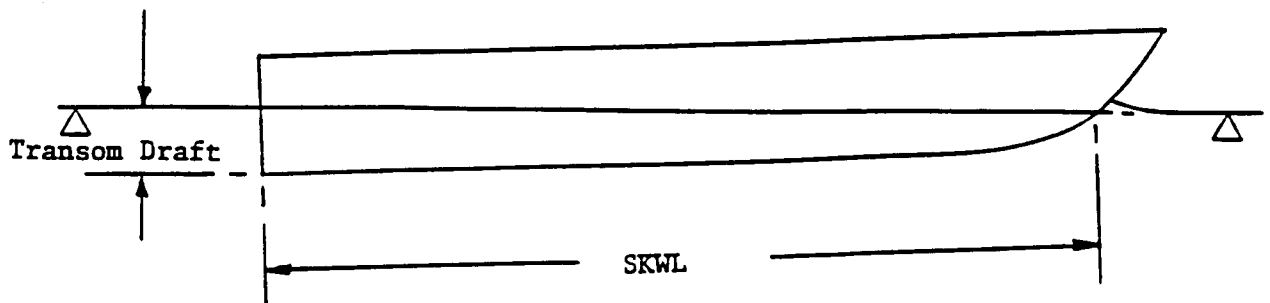

Sketch B - Transom Draft (TD) and Static Keel Wetted Length (SKWL)

RESULTS

The chronological run directory with the test parameters for the 1724 test runs performed during the course of the test program is presented in Appendix B. This is a simple sequential listing of the runs made, showing the computer-assigned Run Number and the test conditions including: radius of turn, the set values of the trim, roll and yaw angles, and the observed test speed. The hydrostatic forces and moments were measured at zero speed for each hull attitude and these runs have the prefix "DZ". Run numbers with the prefix "DR" were general made for checking purposes and were discarded.

The wetted area data from the underwater pictures are next presented in Table 4. The entries in the wetted area tables are presented in exactly the same sequence as in the subsequently presented force and moment tables, to facilitate linking the results together. The occasional blank line occurs when a duplicate data run was made without a corresponding underwater picture; and in a very few instances the pictures did not come out.

The wetted area is given in model dimensional units, and the tabulated values include: the run number, the trim, roll and yaw angles, the keel and starboard chine wetted lengths in model inches, the fraction of the starboard transom that is wet, the port chine wetted length and the fraction of the port transom that is wet. The total wetted area is given in model square feet, followed by the starboard and portside contributions. The SKWL is included for comparison with the dynamic keel wetted length.

The main hydrodynamic stability results are presented in Tables 5 to 8. These tables present respectively: the dimensional model data in wind axes with origin at the tow point, the dimensional model data in body axes with origin at the tow-point, the dimensional model data in body axes with origin at the keel at transom, and the non-dimensional data in body axes with origin at the keel at transom. The tabulated values include: the run number, the trim, roll and yaw angles, the axial, lateral and vertical forces X, Y, and Z, and the roll, pitch and yaw moments K, M, and N. The values of speed, heave, and transom draft are included in Table 5 and in the raw data tables of Appendix A.

The corresponding rudder stability data are presented in Tables 9 to 12. The tabulated values for these straight course tests at 3 degrees trim, and zero roll and yaw, include: the run number, the rudder deflection, the speed, and the forces and moments.

DISCUSSION OF RESULTS

The object of this report is to present the considerable data base obtained from these free-to-heave, fixed trim, roll and yaw tests of the two deadrise models at one displacement and three speeds. A meaningful analysis of this data is clearly desirable, however it is outside the scope of this report. Three topics deserve comment. These include the use of the body axes data, the unusual behavior of the model at zero trim and large yaw angle with increasing speed, and the effect of forward speed on roll stiffness.

While the rotating arm tests were made with zero pitch and roll angular velocity in wind axes, finite values of these angular velocities are induced in body axes due to the trim and roll angles. Moreover the operating conditions of the models are given in terms of the resultant angular yaw velocity in the horizontal plane, and the resultant linear horizontal velocity at the tow point which is located 2.5 beams forward of the transom and 0.46 beams above the keel. These distinctions should be borne in mind when using the body axes system with origin at the pivot and at the transom.

During the rotating arm tests of the model at zero trim the draft increased with yaw angle. Furthermore, at combinations of large negative yaw with positive roll, the model was inundated with water and would have sunk had it not been for the heave stop. The heave stop was a mechanical stop on one heave pole which was set to prevent the model from sinking by more than an inch from its static floating position.

At zero roll angle and zero trim the increase of transom draft with yaw angle is illustrated by the following table, for $C_v = 3$ and $L/R = 0.234$, taken from Table A1.323.1:

Run	1022	1018	1005	1009	1013*
Yaw, deg	-10	-5	0	5	10
TD/beam	0.319	0.267	0.260	0.276	0.372

where the asterisk indicates when the model was close to the heave stop.

Because of this anomalous behavior at zero trim it was decided to eliminate the -2 degrees trim condition from the rotating arm test program, and to curtail the zero trim tests where it seemed advisable at the larger yaw angles. While similar behavior was later noted during the straight course tests, where once again the draft increased with increasing yaw angle at the higher test speeds, it proved feasible to retain the -2 degrees trim test condition.

Once alerted to the possibility of sinkage at zero trim, care was taken *not* to report data where the model was clearly on the stop. Some of the zero trim runs had to be omitted for this reason. Even so, there were still some borderline cases where it was difficult to judge if the model was clear of the heave stop. Therefore it was decided to flag those runs with an asterisk to

show that the heave stop may have interfered with the freedom to heave. The data from runs marked with an asterisk could show some anomalous behavior for this reason.

The zero trim runs on the rotating arm also generated some dramatic spray patterns, which were recorded on video tape. The video record of these tests constitutes an important complement to the tabulated results, and, like the underwater pictures, merits considerable study.

There has been much speculation about the transverse stability of planing hulls at speed. An analysis of the straight course roll stability at zero yaw angle was made by plotting the wind-axes roll moment against roll angle at all speeds and trims. The roll moment tended to vary linearly with roll angle over the range of ± 10 degrees, thereby allowing for the calculation of a roll stiffness. The yaw angular velocity appeared to have little effect on roll stiffness. The variation of straight-course transverse stability with speed is shown on Figure 8 at trims of 0, 3, and 6 degrees for the 30 degree deadrise angle, and for the 10 and 20 degree deadrise angles from Reference 1. At zero trim the 30 degree stability decreased with speed, while at 3 degrees trim the stability increased slightly with speed, and at 6 degrees trim transverse stability was practically independent of speed.

RECOMMENDATIONS

It is obviously most desirable that an in-depth analysis of the data presented herein be carried out. This is a unique data set in the history of planing boats and fills a long felt need. In order to make the results more readily available, the great mass of data must be reduced to manageable form, which would be provided for by appropriate analysis.

As explained in the "Data Processing" section, it was required that the data be presented in both dimensional and non-dimensional form. The specified non-dimensional coefficients reported in Tables 8 and 12 are based on dynamic pressure acting on a characteristic area. The Coast Guard wishes to emphasize that their choice of normalization should not be taken to imply anything about the scaling laws that apply to these data. The issue of scaling is not addressed in this report. The choice of scaling techniques is the responsibility of the user.

Non-dimensional coefficients have many useful applications in Naval Architecture, none of which are associated with scaling. Hydrodynamic data are often presented in non-dimensional form in order either to facilitate the comparison of hull forms, a familiar example being the use of the resistance-weight ratio, R/W , or to achieve a "collapse" of the data. An example of the latter is the use of lift coefficients to report hydrofoil data, which results in characteristics which are substantially independent of speed.

When hydrodynamic data are normalized with respect to the square of the velocity, it is often in the expectation of minimizing velocity effects. In the present case, however, since the resulting coefficients are markedly speed dependent, it is suggested that a different scheme be considered. The authors recommend the use of the NACA planing coefficients which are generally considered to be most suitable for reporting planing data in non-dimensional form. The NACA coefficients are included in the Nomenclature for reference.

Although the data are so extensive they are still limited to one displacement, corresponding to a beam loading of 0.4375, and to one length-beam ratio of 5. The effect of variation in displacement should be investigated for some subset of the parameter space. Similarly it would seem appropriate to investigate the effect of varying the length-beam ratio.

REFERENCES

1. Brown, P. Ward, and Klosinski, Walter E.: Directional Stability Tests of Two Prismatic Planing Hulls
Davidson Laboratory Report 2614, March 1990
USCG R&D Report No. CG-D-11-94,
Government Accession No. AD-A 282782

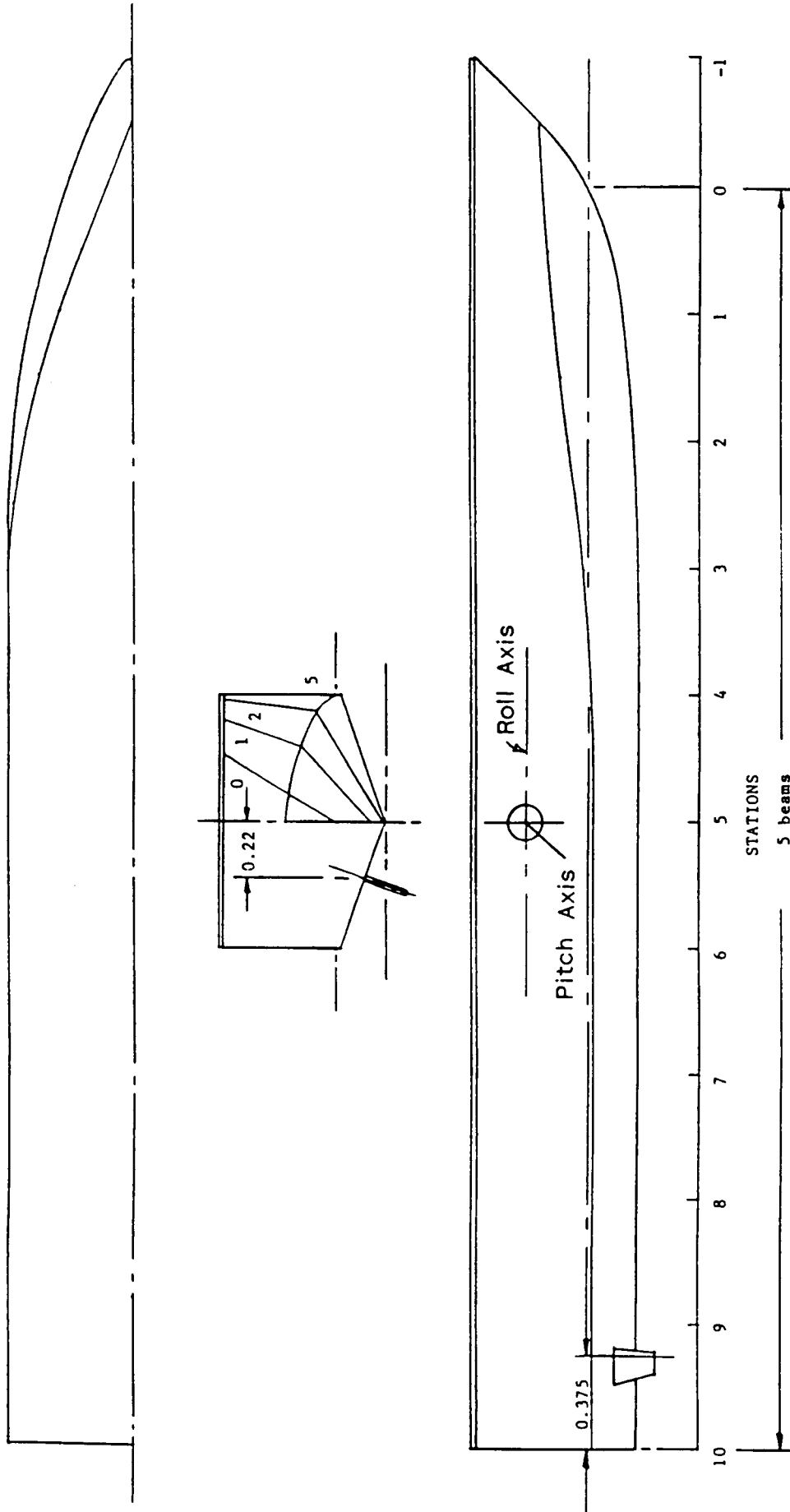

FIGURE 1 LINES OF 20° PARENT MODEL

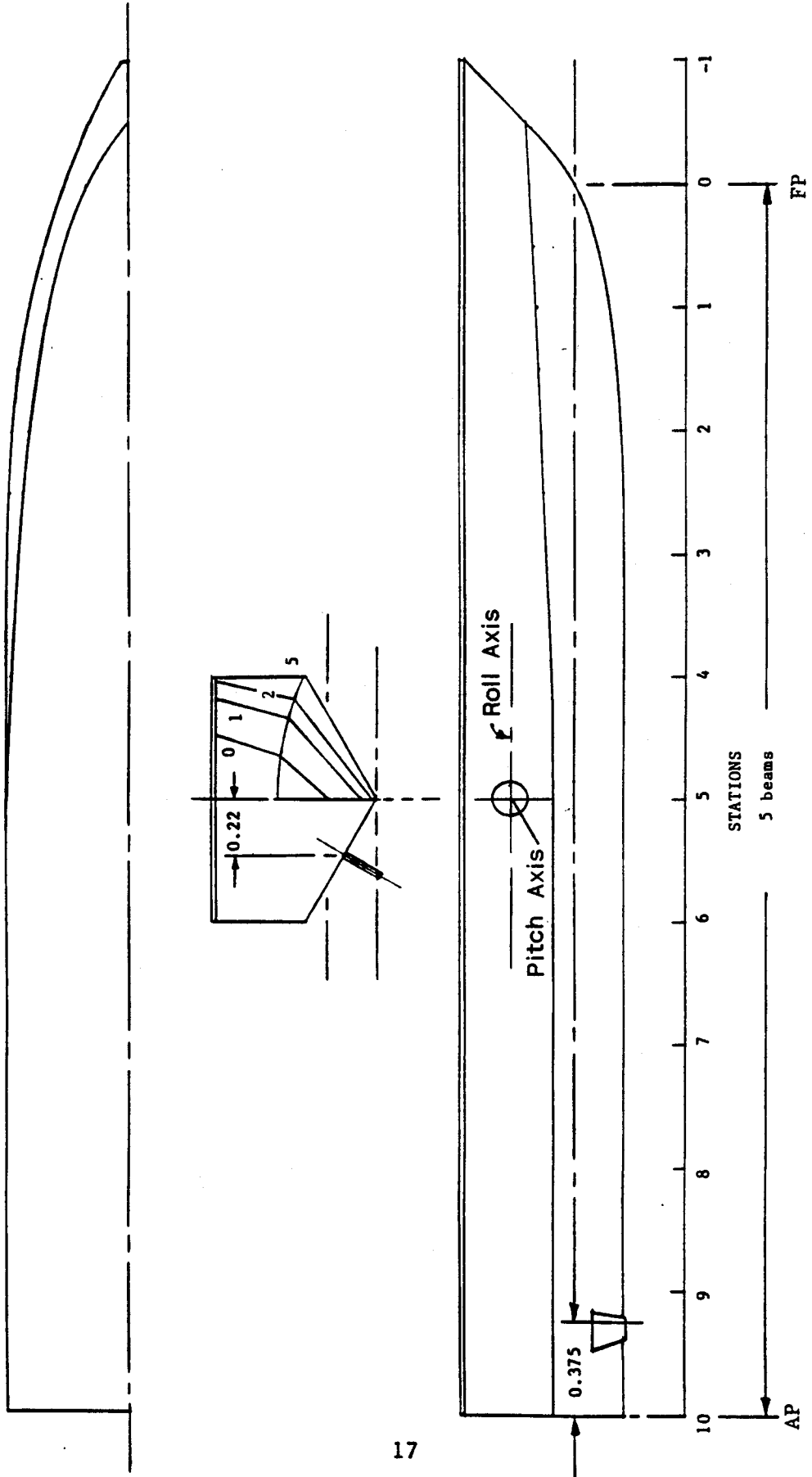

FIGURE 2 LINES OF 30° DEADRISE MODEL

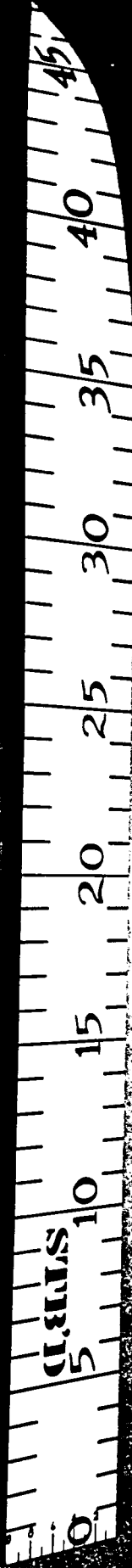

FIGURE 3 PHOTOGRAPH OF 30° DEADRISE MODEL

R-2658

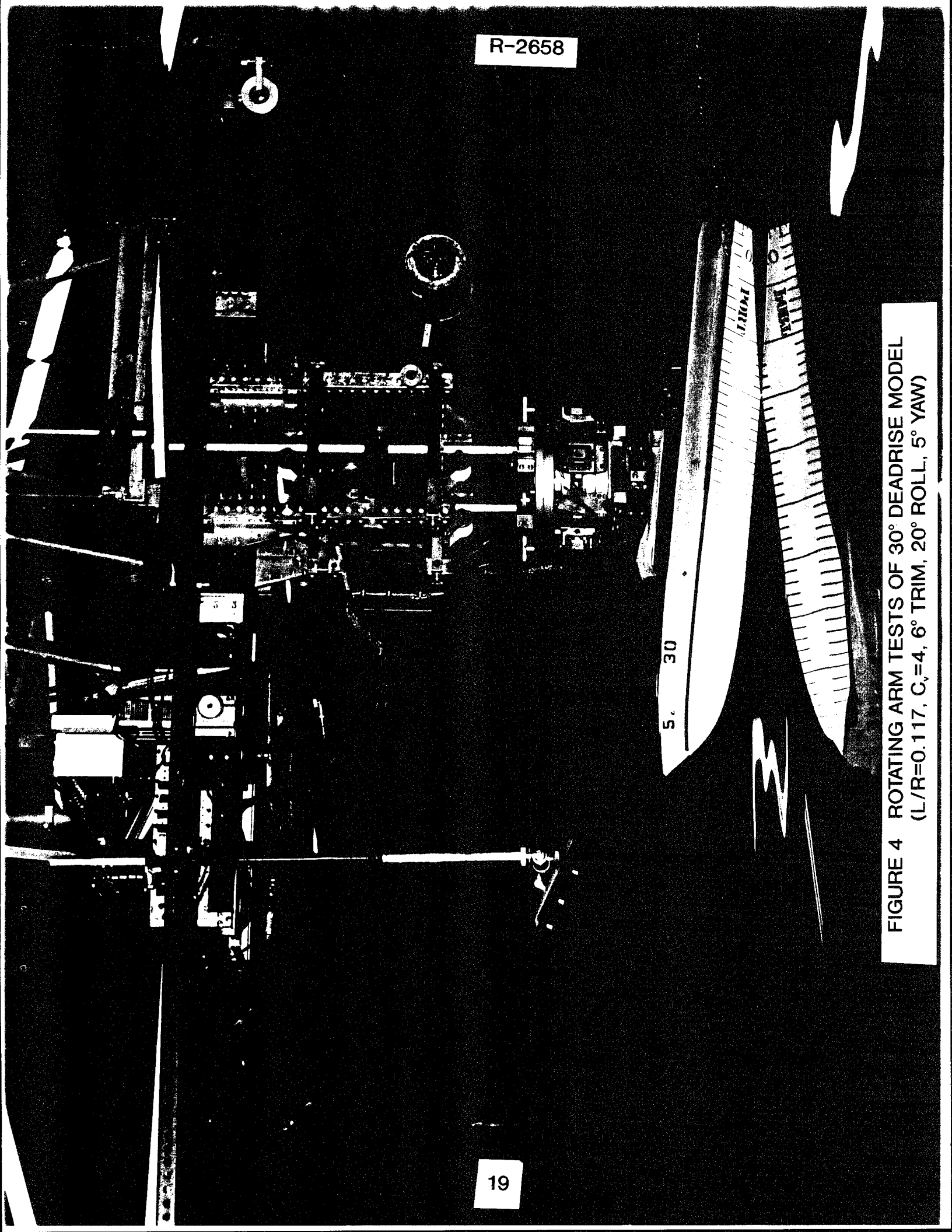

FIGURE 4 ROTATING ARM TESTS OF 30° DEADRISE MODEL
(L/R=0.117, $C_v=4$, 6° TRIM, 20° ROLL, 5° YAW)

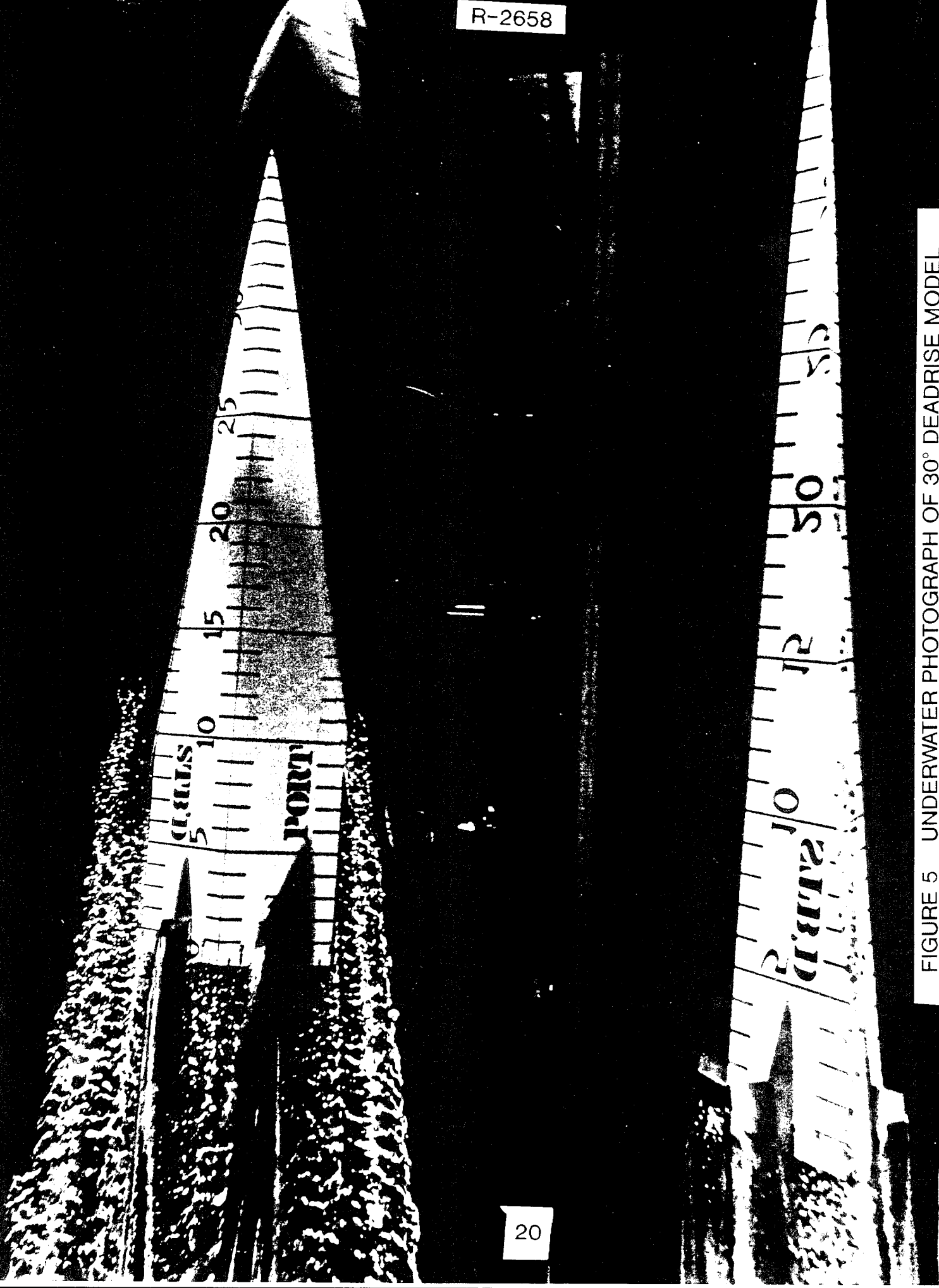

FIGURE 5 UNDERWATER PHOTOGRAPH OF 30° DEADRISE MODEL
(L/R=0.0, C_v=3, 3° TRIM, 0° ROLL & YAW, -20° RUDDER)

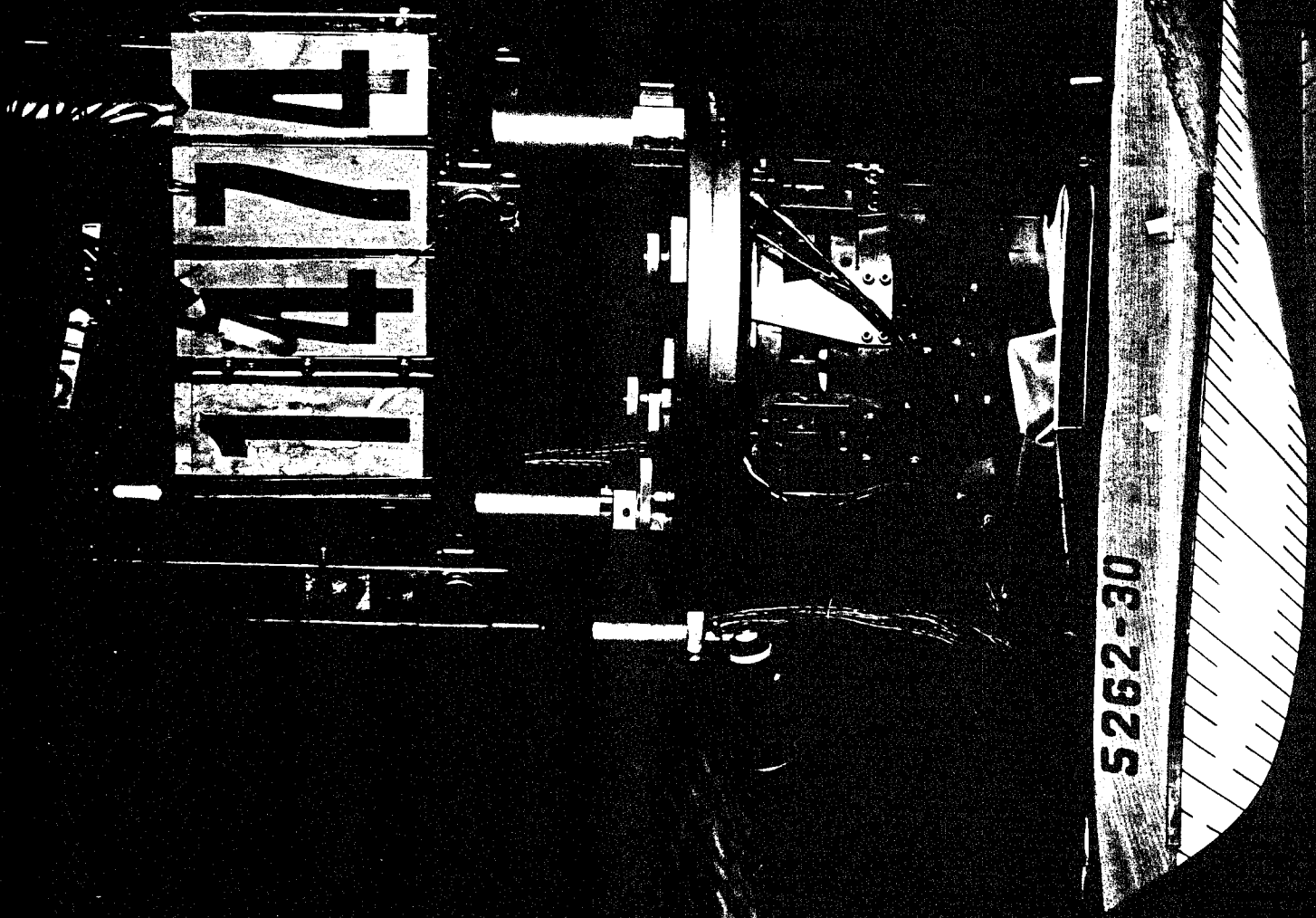

FIGURE 6 STRAIGHT COURSE TESTS OF 30° DEADRISE MODEL
(L/R=0.0, $C_v=3$, 6° TRIM, 10° ROLL, 15° YAW)

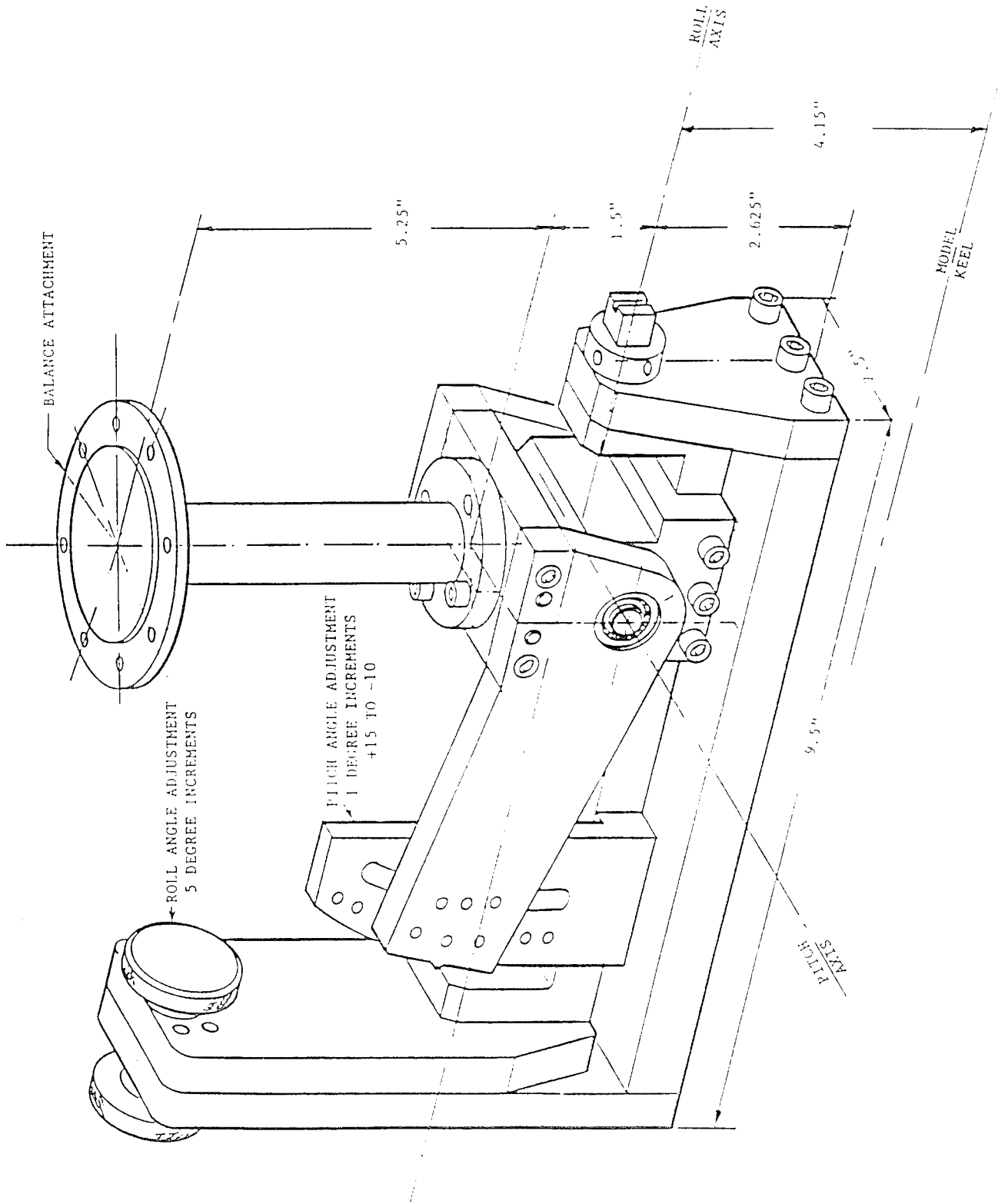

FIGURE 7 PITCH AND ROLL PIVOT BOX

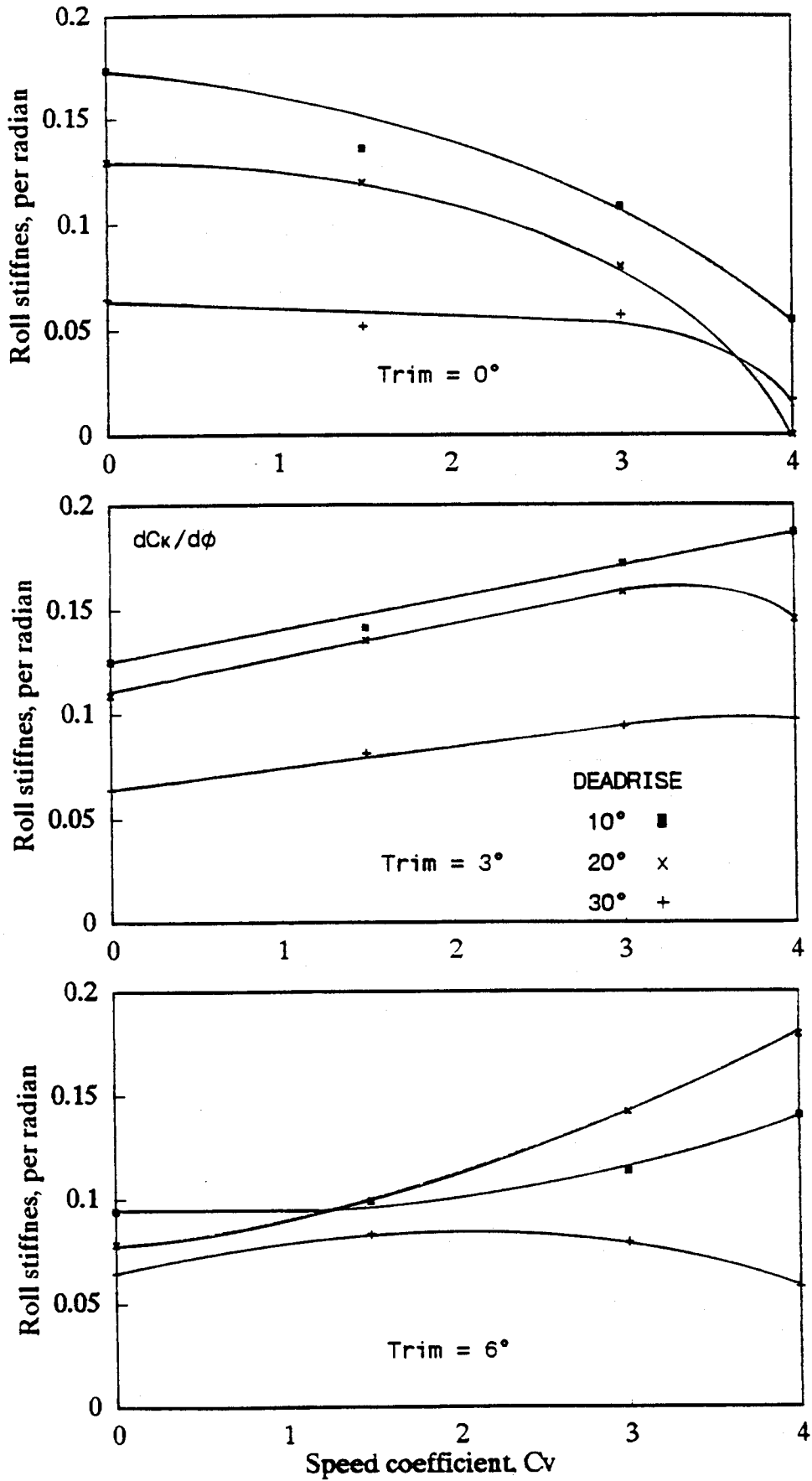

FIGURE 8 VARIATION OF STRAIGHT COURSE ROLL STABILITY WITH SPEED

TABLE 1

TABLE OF MODEL PARTICULARS

	Model	Full Size		
Scale	1/26.6	1		
Displacement, Δ	11.49 lb	100 long tons		
Load coefficient, C_{Δ}	0.4375	0.4375		
Beam	9 in	20 ft		
Lengths				
Overall, LOA	50 in	110 ft		
Projected chine LP	47.5 in	105 ft		
Design, DWL or LBP	45 in	100 ft		
Length-beam ratios				
Overall	5.50	5.50		
Projected chine	5.25	5.25		
Between perpendiculars	5.00	5.00		
Towpoint				
Forward of transom	22.5 in			
Above keel	4.15 in			
Twin Rudders				
Root chord	1.31 in	35 in		
Tip chord	0.75 in	20 in		
Span	1.58 in	42 in		
Sweepback angle	4.09 deg	4.09 deg		
Area per rudder	1.62 sq.in	8.02 sq.ft		
Rudder Section - offsets in percent chord				
	Distance	Thickness	Distance	Thickness
	from L.E.	t/c %	from L.E.	t/c %
L.E.	0	0.0	50	11.3
	5	10.0	60	10.0
	10	11.8	70	8.3
	20	12.4	80	6.5
	30	12.4	90	4.7
	40	12.1	T.E. 100	3.0

TABLE 2.300.1

STRAIGHT COURSE RUN DIRECTORY
FOR TABLES nn.300

30 deg deadrise - L/R = 0

CV = 0

YAW, deg ⇔	-15	-10	-5	0	5	10	15
ROLL, deg	Trim -2 deg						
8							
-10				1641	1645	1648	1651
0				1588	1593	1607	1610
10				1614	1618	1621	1624
20				1628	1632	1635	1638
	Trim = 0 deg						
-10				1571	1575	1579	1583
0				1511	1527	1532	1535
10				1539	1543	1547	1550
20				1553	1557	1561	1565
	Trim = 3 deg						
-10				1374	1379	1382	1386
0				1301	1309	1313	1318
				1307			
				1689			
10				1324	1328	1332	1336
20				1342	1359	1363	1367

* Indicates model was close to heave stop

TABLE 2.300.2

STRAIGHT COURSE RUN DIRECTORY
FOR TABLES nn.300

30 deg deadrise - L/R = 0

Cv = 0

YAW, deg ⇔	-15	-10	-5	0	5	10	15
ROLL, deg				Trim 6 deg			
↓							
-10				1494	1498	1502	1506
0				1405 1438	1409	1440	1444 1455
10				1460	1464	1468	1472
20				1477	1481	1485	1489

* Indicates model was close to heave stop

TABLE 2.301.1

STRAIGHT COURSE RUN DIRECTORY
FOR TABLES nn.301

30 deg deadrise - L/R = 0

CV = 1.5

YAW, deg ⇒	-15	-10	-5	0	5	10	15
ROLL, deg	Trim -2 deg						
↓							
-10				1642	1646	1649	1652
0				1589	1594	1608	1611 *
10				1615	1619	1622	1625 *
20				1629	1633	1636	1639 *
	Trim = 0 deg						
-10				1572	1576	1580	1584
0				1512	1528	1533	1536
10				1540	1544	1548	1551
20				1554	1558	1562	1566
	Trim = 3 deg						
-10				1375	1378	1383	1387
0				1302	1310	1314	1319
				1303			
				1308			
10				1325	1329	1333	1337
20				1343	1360	1364	1368 1370

* Indicates model was close to heave stop

TABLE 2.301.2

STRAIGHT COURSE RUN DIRECTORY
FOR TABLES nn.301

30 deg deadrise - L/R = 0

Cv = 1.5

YAW, deg ⇒	-15	-10	-5	0	5	10	15
ROLL, deg				Trim 6 deg			
↓							
-10				1495	1499	1503	1507
0				1406	1410	1441	1456
10				1461	1465	1469	1473
20				1478	1482	1486	

* Indicates model was close to heave stop

TABLE 2.303.1

STRAIGHT COURSE RUN DIRECTORY
FOR TABLES nn.303

30 deg deadrise - L/R = 0

Cv = 3

YAW, deg ⇒	-15	-10	-5	0	5	10	15
ROLL, deg	Trim -2 deg						
↓							
-10				1643	1647	1650 *	
0				1590	1595	1609 *	
10				1616	1620	1623 *	
20				1630	1634	1637 *	
	Trim = 0 deg						
-10				1573	1577	1581	1585
0				1513	1530	1534	
10				1541	1545	1549	
20				1555	1559	1563	1567
	Trim = 3 deg						
-10				1376	1380 1668	1384	1388
0				1305 1654	1311 1655	1316 1656	1320 1657
10				1326 1660	1330 1659	1334 1661	1338 1662
20				1344 1664	1361 1665	1365 1666	1369 1371 1667

* Indicates model was close to heave stop

TABLE 2.303.2

STRAIGHT COURSE RUN DIRECTORY
FOR TABLES nn.303

30 deg deadrise - L/R = 0

Cv = 3

YAW, deg ⇒	-15	-10	-5	0	5	10	15
ROLL, deg	Trim 6 deg						
↓							
-10				1496	1500	1504	1508
0				1407	1411	1442	1457
10				1462	1466	1470	1474
20				1479	1483	1487	1491

* Indicates model was close to heave stop

TABLE 2.304.1

STRAIGHT COURSE RUN DIRECTORY
FOR TABLES nn.304

30 deg deadrise - L/R = 0

CV = 4

YAW, deg ⇒	-15	-10	-5	0	5	10	15
ROLL, deg				Trim -2 deg			
↓							
-10				1644 *			
0				1592 *	1596 *		
10				1617 *			
20				1631 *			
				Trim = 0 deg			
-10				1574	1578	1582	1586
0				1515	1531		
10				1542	1546		
20				1556	1560	1564	1568
				Trim = 3 deg			
-10				1377	1381	1385	1389
0				1306	1312	1317 1322	1321
10				1327	1331	1335	1339 1340
20				1345	1362	1366	1372

* Indicates model was close to heave stop

TABLE 2.304.2

STRAIGHT COURSE RUN DIRECTORY
FOR TABLES nn.304

30 deg deadrise - L/R = 0

Cv = 4

YAW, deg ⇔	-15	-10	-5	0	5	10	15
ROLL, deg				Trim 6 deg			
↓							
-10				1497	1501	1505	1509
0				1408	1412 1439	1443	1458
10				1463	1467	1471	1475
20				1480	1484	1488	1492

* Indicates model was close to heave stop

TABLE 2.310

 ROTATING ARM RUN DIRECTORY
 FOR TABLES nn.310

30 deg deadrise - L/R = 0.117

Cv = 0

YAW, deg ⇒	-15	-10	-5	0	5	10	15
ROLL, deg	Trim 0 deg						
↓							
-10	563	560	555	527 548	531	535	551
0	463	460	456	77 441 476	446	451	454
10	495	491	487	466	478	482	485
20	522	518	514	500	504	508	512
	Trim = 3 deg						
-10	275	271	266	245	250	256	260
0	128	123	119	80	85	110	114
10	190	183	179	137 169	145	149	
20	239	234	230	196	203	208 209	213 227
	Trim = 6 deg						
-10	436	432	428	403	407	411	424
0	323	317	311	289	295	298	302 308
10	364	359	346 355	329	334	338	342 369
20	397	393	389	372	376	381	385

* Indicates model was close to heave stop

TABLE 2.311

 ROTATING ARM RUN DIRECTORY
 FOR TABLES nn.311

30 deg deadrise - L/R = 0.117

Cv = 1.5

YAW, deg ⇔	-15	-10	-5	0	5	10	15
ROLL, deg	Trim 0 deg						
↓							
-10	564 *	561	556	528	532	536	550
0	464 *	461	457	78 443	448	452	455 *
10	496	492	488	467	479	483	486 *
20	523	519	515	501	505	509	513
	Trim = 3 deg						
-10	276	272	267	246	249 251 253	257	261
0	129	124	120	81	87 107	111	115 135
10	188	184	180	138	144 146	150	170 173 174
20	240	235	231	197	204	210	214
	Trim = 6 deg						
-10	437	433	429	404	408	412	425
0	325	318	312	290	294	299	303 309
10	365	360	347	330	335	339	343
20	398	394	390	373	377	382	386

* Indicates model was close to heave stop

TABLE 2.313

 ROTATING ARM RUN DIRECTORY
 FOR TABLES nn.313

30 deg deadrise - L/R = 0.117

Cv = 3

YAW, deg ⇒	-15	-10	-5	0	5	10	15
ROLL, deg	Trim 0 deg						
↓							
-10		562 *	558	529	533	537	552
0		462 *	458	444	449	453 *	
10	497	493	489	468	480	484	
20	524	520	516	502	506	510	
	Trim = 3 deg						
-10	277	273	269	247	254	258	262
0	130	125	121	82	88	112	116
					101		132
					105		
10	191	185	181	141	147	151	175
20	241	236	232	200	206	211	215
							216
	Trim = 6 deg						
-10	438	434	430	405	409	413	426
0	326	319	315	292	296	300	304
10	366	361	357	331	336	340	344
		363					
20	400	395	391	374	378	383	387

* Indicates model was close to heave stop

TABLE 2.314

 ROTATING ARM RUN DIRECTORY
 FOR TABLES nn.314

30 deg deadrise - L/R = 0.117

Cv = 4

YAW, deg ⇔	-15	-10	-5	0	5	10	15
ROLL, deg	Trim 0 deg						
↓							
-10			559	530	534	554 *	553
0			459	445	450		
10	498	494	490	469	481		
20	525	521	517	503	507		
	Trim = 3 deg						
-10	278	274	270	248	255	259	265
0	131	126	122	83	106	113	117 133
10	192 193	186	182	143	148	153	178
20	243	238	233	201 202	207	212	229
	Trim = 6 deg						
-10	439	435	431	406	410	414	427
0	327	322	316	293	297	301	306
10	368	362	358	333	337	341	345 370
20	401	396	392	375	379 380	384	388

* Indicates model was close to heave stop

TABLE 2.320

 ROTATING ARM RUN DIRECTORY
 FOR TABLES nn.320

30 deg deadrise - L/R = 0.234

Cv = 0

YAW, deg ⇒	-15	-10	-5	0	5	10	15
ROLL, deg	Trim 0 deg						
↓							
-10	1126	1122	1117	1101	1105	1110	1113
0	1024	1020	1016	1003 1085	1007	1011	1014
10	1058	1054	1050	1035	1039	1043	1048
20	1096	1092	1087	1063	1067	1072	1076
	Trim = 3 deg						
-10	832	828	824	800		816	820
0	692	688 699	684 704	657 708	661 712	675 718	679 722
10	764	760	756	726	752	730 743	748
20	795	791	787	771	775	779	783
	Trim = 6 deg						
-10	994	989	985	962	965	977	981
0	864	860	856	839	844	848	852
10	923	919	915	869 881 912	888	892	898 913
20	955	951	946	928	932	936	943

* Indicates model was close to heave stop

TABLE 2.321

 ROTATING ARM RUN DIRECTORY
 FOR TABLES nn.321

30 deg deadrise - L/R = 0.234

Cv = 1.5

YAW, deg ⇔	-15	-10	-5	0	5	10	15
ROLL, deg	Trim 0 deg						
↓							
-10	1127 1129 *	1123	1118	1102	1106	1111	1114
0	1025	1021	1017	1004	1008	1012	1015 *
10	1059	1055	1051	1036	1040	1044 1045	1049
20	1097	1093	1088	1064	1068	1071 1073	1077
	Trim = 3 deg						
-10	833	829	825	801	813	817	821
0	698	689 700	685 705	658 711	662 713	676 719	680 723
10	765	761	757	727	753	731	749
20	796	792	788	772	776	780	784
	Trim = 6 deg						
-10	995	990 991	986	960 961	966	978	982
0	865	861	857	840	845	849	853
10	924	920	916	870 871	889	893 894	899
20	956	952	947	929	933	937	941 942

* Indicates model was close to heave stop

TABLE 2.323

 ROTATING ARM RUN DIRECTORY
 FOR TABLES nn.323

30 deg deadrise - L/R = 0.234

Cv = 3

YAW, deg →	-15	-10	-5	0	5	10	15
ROLL, deg	Trim 0 deg						
‡							
-10	1128 *	1124	1120	1103	1108	1112	1115
0	1026	1022	1018	1005	1009	1013 *	
10	1060	1056	1052	1037	1041	1046	
20	1098	1094	1089	1065	1069	1074	1078 *
	Trim = 3 deg						
-10	834	830	826	802	814	818	822
0	697	690 701	706	659 710	663 714	677 720	724
10	766	762	758	728	754	732 744	750
20	797	793	789	773	777	781	785
	Trim = 6 deg						
-10	996	992	987	963	967	979	983
0	866	862	858	842	846	850	854
10	925	921	917	882 883 884 885 886	890	895 896	900
20	957	953	948	930	934	939	944

* Indicates model was close to heave stop

TABLE 2.324

 ROTATING ARM RUN DIRECTORY
 FOR TABLES nn.324

30 deg deadrise - L/R = 0.234

CV = 4

YAW, deg ⇔	-15	-10	-5	0	5	10	15
ROLL, deg ↓	Trim 0 deg						
-10		1125 *	1121	1104	1109		1116
0	1027	1023 *	1019	1006	1010		
10	1061	1057	1053	1038	1042	1047 *	
20	1099	1095	1091	1066	1070	1075	
	Trim = 3 deg						
-10	835	831	827	803	815	819	823
0	696	702 703	707	660 709	664 715	678 721	
10	767 768	763	759	729	755	746 747	751
20	798	794	790	774	778	782	786
	Trim = 6 deg						
-10	997	993	988	964	968 998	980 999	984
0	867	863	859	843	847	851	855
10	926	922	918	887	891	897	901 902 903
20	958	954	949 950	931	935	940	914 945

* Indicates model was close to heave stop

TABLE 3

DIRECTORY OF STRAIGHT COURSE RUDDER RUNS
FOR TABLES 9 TO 12

30 deg deadrise - L/R = 0

Roll = Yaw = 0 deg

Trim = 3 deg

RUDDER, deg ⇒ -20 -15 -10 -5 0 5 10 15

Cv = 1.5

1712	1709	1706	1703	1700	1724	1719	1718
1713							

Cv = 3

1714	1710	1707	1704	1701	1723	1720	1717
------	------	------	------	------	------	------	------

Cv = 4

1715	1711	1708	1705	1702	1722	1721	1716
------	------	------	------	------	------	------	------

* Indicates model was close to heave stop

TABLE 4.301.1 - WETTED AREA DATA

30 deg Deadrise, L/R = 0.000, Cv = 1.5

RUN	Trim deg	Roll deg	Yaw deg	Wetted Lengths					Wetted Areas			SKWL in
				Keel Lk in	Stbd Chine Lcs in	Stbd Beam Bs :	Port Chine Lcp in	Port Beam Bp :	Total Atot sq.ft	Stbd As sq.ft	Port Ap sq.ft	
1642	-2	-10	0	48.0	48.0	0.6	48.0	1.0	2.46	0.92	1.53	47.07
1646	-2	-10	5	47.5	42.0	0.5	47.5	1.0	2.30	0.76	1.53	47.16
1649	-2	-10	10	48.0	40.0	0.5	48.0	1.0	2.29	0.76	1.53	47.39
1652	-2	-10	15	49.0	42.0	0.5	49.0	1.0	2.31	0.77	1.53	47.70
1589	-2	0	0	47.5	47.5	0.9	47.5	0.9	2.76	1.38	1.38	47.04
1594	-2	0	5	47.5	47.5	0.9	47.5	0.9	2.76	1.38	1.38	47.15
1608	-2	0	10	48.0	48.0	1.0	48.0	0.9	2.92	1.53	1.38	47.45
1611 *	-2	0	15	48.0	48.0	1.0	48.0	1.0	3.07	1.53	1.53	47.86
1615	-2	10	0	47.5	47.5	1.0	35.0	0.8	2.70	1.53	1.16	47.08
1619	-2	10	5	48.0	48.0	1.0	48.0	0.9	2.92	1.53	1.38	47.20
1622	-2	10	10	48.0	48.0	1.0	48.0	0.9	2.92	1.53	1.38	47.45
1625 *	-2	10	15	48.5	48.5	1.0	48.5	0.9	2.92	1.53	1.38	47.99
1629	-2	20	0	47.5	47.5	1.0	47.5	0.8	2.76	1.53	1.23	46.81
1633	-2	20	5	47.5	47.5	1.0	36.0	0.6	2.41	1.53	0.88	46.98
1636	-2	20	10	48.0	48.0	1.0	36.0	0.7	2.57	1.53	1.03	47.36
1639 *	-2	20	15	48.5	48.5	1.0	36.0	0.7	2.57	1.53	1.04	47.99
1572	0	-10	0	46.3	37.0	0.7	46.3	1.0	2.55	1.02	1.53	45.64
1576	0	-10	5	46.5	35.0	0.7	46.5	1.0	2.54	1.01	1.53	45.70
1580	0	-10	10	47.0	40.0	0.5	47.0	1.0	2.28	0.75	1.53	45.87
1584	0	-10	15	47.0	38.0	0.4	47.0	1.0	2.13	0.59	1.53	46.22
1512	0	0	0	46.3	46.3	1.0	46.3	1.0	3.06	1.53	1.53	45.83
1528	0	0	5	46.3	46.3	1.0	46.3	1.0	3.06	1.53	1.53	45.75
1533	0	0	10	47.0	47.0	1.0	47.0	1.0	3.07	1.53	1.53	45.98
1536	0	0	15	47.0	47.0	1.0	47.0	1.0	3.07	1.53	1.53	46.40
1540	0	10	0	46.3	46.3	1.0	39.0	0.6	2.42	1.53	0.89	45.63
1544	0	10	5	46.3	46.3	1.0	36.0	0.8	2.69	1.53	1.16	45.69
1548	0	10	10	46.3	46.3	1.0	40.0	0.9	2.87	1.53	1.34	45.91
1551	0	10	15	47.0	47.0	1.0	47.0	0.9	2.92	1.53	1.38	46.36
1554	0	20	0	46.0	46.0	1.0	41.0	0.3	1.98	1.53	0.45	45.38
1558	0	20	5	46.0	46.0	1.0	35.0	0.8	2.67	1.53	1.14	45.45
1562	0	20	10	46.3	46.3	1.0	35.0	0.7	2.53	1.53	1.00	45.72
1566	0	20	15	47.0	47.0	1.0	35.0	0.8	2.69	1.53	1.16	46.25
1375	3	-10	0	42.7	25.0	0.9	32.5	1.0	2.44	1.10	1.34	41.91
1378	3	-10	5	42.8	38.0	0.9	33.0	1.0	2.62	1.27	1.35	42.04
1383	3	-10	10	43.2	0.0	0.9	35.0	1.0	2.08	0.70	1.38	42.60
1387	3	-10	15	43.8	0.0	0.5	36.5	1.0	1.81	0.40	1.41	43.03
1302	3	0	0	43.0	28.5	1.0	28.5	1.0	2.56	1.28	1.28	43.04
1303	3	0	0	43.1	28.7	1.0	28.7	1.0	2.57	1.29	1.29	43.11
1308	3	0	0	43.0	28.5	1.0	29.0	1.0	2.57	1.28	1.29	43.09
1310	3	0	5	43.0	31.0	1.0	29.0	1.0	2.61	1.32	1.29	43.09
1314	3	0	10	43.3	15.0	1.0	31.5	1.0	2.39	1.05	1.33	43.32
1319	3	0	15	44.0	21.0	1.0	35.0	1.0	2.57	1.17	1.40	43.94

* Indicates model was close to heave stop

TABLE 4.301.2 - WETTED AREA DATA

30 deg Deadrise, L/R = 0.000, Cv = 1.5

RUN	Trim deg	Roll deg	Yaw deg	Wetted Lengths					Wetted Areas			SKWL in
				Keel Lk in	Stbd Chine Lcs in	Stbd Beam Bs :	Port Chine Lcp in	Port Beam Bp :	Total Atot sq.ft	Stbd As sq.ft	Port Ap sq.ft	
1325	3	10	0	42.6	32.7	1.0	32.0	0.9	2.54	1.34	1.20	42.69
1329	3	10	5	42.5	33.0	1.0	27.0	1.0	2.59	1.34	1.25	42.81
1333	3	10	10	43.2	33.5	1.0	26.0	1.0	2.61	1.36	1.24	43.14
1337	3	10	15	43.8	35.0	1.0	30.0	1.0	2.71	1.39	1.32	43.67
1343	3	20	0	42.0	36.0	1.0	25.0	0.7	2.22	1.38	0.84	41.86
1360	3	20	5	42.0	36.0	1.0	25.0	0.7	2.22	1.38	0.84	41.15
1364	3	20	10	42.3	37.0	1.0	24.0	0.8	2.35	1.40	0.96	41.73
1368	3	20	15	43.3	38.5	1.0	26.0	1.0	2.68	1.43	1.25	42.83
1370	3	20	15	43.3	39.0	1.0	26.0	1.0	2.68	1.44	1.25	42.85
1495	6	-10	0	36.0	10.0	1.0	26.0	1.0	1.95	0.83	1.12	35.38
1499	6	-10	5	36.2	0.0	1.0	26.0	1.0	1.77	0.65	1.12	35.60
1503	6	-10	10	36.5	6.0	1.0	27.0	1.0	1.91	0.77	1.14	36.03
1507	6	-10	15	37.6	8.0	1.0	28.8	1.0	2.02	0.82	1.19	37.07
1406	6	0	0	41.2	22.0	1.0	22.0	1.0	2.28	1.14	1.14	35.17
1410	6	0	5	36.3	21.0	1.0	22.3	1.0	2.09	1.03	1.06	35.32
1441	6	0	10									35.02
1456	6	0	15	37.7	17.0	1.0	25.0	1.0	2.12	0.99	1.13	36.58
1461	6	10	0	35.7	26.0	1.0	10.0	1.0	1.94	1.11	0.83	35.23
1465	6	10	5	35.3	25.5	1.0	18.5	1.0	2.07	1.10	0.97	35.08
1469	6	10	10	36.1	25.0	1.0	19.8	1.0	2.11	1.10	1.01	35.75
1473	6	10	15	37.2	27.0	1.0	22.0	1.0	2.22	1.16	1.07	36.80
1478	6	20	0	34.3	28.7	1.0	0.0	0.9	1.69	1.13	0.56	33.45
1482	6	20	5	34.3	29.0	1.0	0.0	0.0	1.14	1.14	0.00	33.71
1486	6	20	10	35.0	29.1	1.0	17.0	1.0	2.09	1.15	0.94	34.09

* Indicates model was close to heave stop

TABLE 4.303.1 - WETTED AREA DATA

30 deg Deadrise, L/R = 0.000, Cv = 3

RUN	Trim deg	Roll deg	Yaw deg	Wetted Lengths					Wetted Areas			SKWL in
				Keel Lk in	Stbd Chine Lcs in	Stbd Beam Bs :	Port Chine Lcp in	Port Beam Bp :	Total Atot sq.ft	Stbd As sq.ft	Port Ap sq.ft	
1643	-2	-10	0	48.0	48.0	1.0	48.0	1.0	3.07	1.53	1.53	47.26
1647	-2	-10	5	48.0	48.0	1.0	48.0	1.0	3.07	1.53	1.53	47.59
1650 *	-2	-10	10	49.0	49.0	1.0	49.0	1.0	3.07	1.53	1.53	47.95
1590	-2	0	0	47.5	47.5	0.9	47.5	0.9	2.76	1.38	1.38	47.24
1595	-2	0	5	48.0	48.0	1.0	48.0	1.0	3.07	1.53	1.53	47.56
1609 *	-2	0	10									47.98
1616	-2	10	0	48.0	48.0	1.0	48.0	1.0	3.07	1.53	1.53	47.30
1620	-2	10	5	48.0	48.0	1.0	48.0	1.0	3.07	1.53	1.53	47.59
1623 *	-2	10	10	48.5	48.5	1.0	48.5	1.0	3.07	1.53	1.53	47.97
1630	-2	20	0	48.0	48.0	1.0	48.0	0.9	2.92	1.53	1.38	47.07
1634	-2	20	5	48.0	48.0	1.0	48.0	1.0	3.07	1.53	1.53	47.56
1637 *	-2	20	10	48.5	48.5	1.0	48.5	1.0	3.07	1.53	1.53	47.98
1573	0	-10	0	46.0	30.0	0.8	46.0	1.0	2.62	1.09	1.53	45.35
1577	0	-10	5	46.0	28.0	0.7	43.0	1.0	2.44	0.93	1.51	45.49
1581	0	-10	10	46.5	38.0	0.4	45.0	1.0	2.12	0.59	1.53	45.70
1585	0	-10	15	45.3	45.0	0.4	39.0	1.0	2.07	0.61	1.47	45.01
1513	0	0	0	46.0	46.0	1.0	46.0	1.0	3.06	1.53	1.53	45.55
1530	0	0	5	46.3	46.3	1.0	46.3	1.0	3.06	1.53	1.53	45.59
1534	0	0	10	47.0	47.0	1.0	47.0	1.0	3.07	1.53	1.53	46.39
1541	0	10	0	46.0	46.0	1.0	32.0	0.7	2.50	1.53	0.97	45.35
1545	0	10	5	46.2	46.2	1.0	46.2	1.0	3.06	1.53	1.53	45.59
1549	0	10	10	47.0	47.0	1.0	47.0	1.0	3.07	1.53	1.53	46.36
1555	0	20	0	45.5	43.0	1.0	30.0	0.5	2.18	1.51	0.67	45.05
1559	0	20	5	46.0	46.0	1.0	25.0	0.9	2.68	1.53	1.15	45.40
1563	0	20	10	46.3	46.3	1.0	46.3	1.0	3.06	1.53	1.53	46.06
1567	0	20	15									46.23
1376	3	-10	0	40.7	15.0	1.0	27.0	1.0	2.22	1.01	1.22	39.95
1380	3	-10	5	40.8	0.0	0.8	28.0	1.0	1.82	0.59	1.24	40.19
1668	3	-10	5	41.0	0.0	0.8	28.0	1.0	1.83	0.59	1.24	40.53
1384	3	-10	10	42.0	0.0	0.8	31.0	1.0	1.91	0.61	1.30	41.26
1388	3	-10	15	33.9	0.0	0.2	16.0	1.0	1.02	0.12	0.90	32.70
1305	3	0	0									41.32
1654	3	0	0	41.3	21.0	1.0	21.0	1.0	2.25	1.12	1.12	40.76
1311	3	0	5									41.53
1655	3	0	5	41.4	23.0	1.0	21.0	1.0	2.29	1.16	1.13	40.97
1316	3	0	10									42.43
1656	3	0	10	42.5	20.0	1.0	27.5	1.0	2.39	1.13	1.26	42.08
1320	3	0	15									43.86
1657	3	0	15	44.5	25.0	1.0	35.7	1.0	2.67	1.25	1.41	43.86

* Indicates model was close to heave stop

TABLE 4.303.2 - WETTED AREA DATA

30 deg Deadrise, L/R = 0.000, Cv = 3

RUN	Trim deg	Roll deg	Yaw deg	Wetted Lengths					Wetted Areas			SKWL in
				Keel Lk in	Stbd Chine Lcs in	Stbd Beam Bs :	Port Chine Lcp in	Port Beam Bp :	Total Atot sq.ft	Stbd As sq.ft	Port Ap sq.ft	
1326	3	10	0									40.87
1660	3	10	0	41.0	27.5	1.0	13.0	1.0	2.21	1.23	0.97	40.36
1330	3	10	5									41.00
1659	3	10	5	41.0	27.0	1.0	16.0	1.0	2.25	1.22	1.03	40.57
1334	3	10	10									41.65
1661	3	10	10	41.5	28.2	1.0	20.0	1.0	2.36	1.25	1.11	41.05
1338	3	10	15	42.9	31.5	1.0	25.0	1.0	2.55	1.33	1.22	43.00
1662	3	10	15	43.3	33.2	1.0	28.5	1.0	2.65	1.36	1.29	43.03
1344	3	20	0									39.74
1664	3	20	0	39.8	22.0	1.0	12.0	0.9	1.96	1.12	0.84	38.95
1361	3	20	5	39.5	31.0	1.0	8.5	1.0	2.13	1.26	0.87	38.47
1665	3	20	5	39.3	31.6	1.0	10.0	1.0	2.16	1.27	0.89	39.01
1365	3	20	10									38.06
1666	3	20	10	39.3	31.0	1.0	11.0	1.0	2.17	1.26	0.91	38.71
1369	3	20	15									38.95
1371	3	20	15	39.5	31.5	1.0	13.7	1.0	2.23	1.27	0.96	38.89
1667	3	20	15	40.0	32.0	1.0	14.0	1.0	2.26	1.28	0.97	39.44
1496	6	-10	0	27.0	10.0	1.0	16.0	1.0	1.44	0.67	0.78	26.57
1500	6	-10	5	28.6	10.5	1.0	18.0	1.0	1.55	0.71	0.84	27.91
1504	6	-10	10	29.2	0.0	1.0	19.0	1.0	1.40	0.53	0.87	28.77
1508	6	-10	15	33.9	6.0	1.0	24.0	1.0	1.76	0.72	1.04	33.50
1407	6	0	0	27.0	12.0	1.0	11.9	1.0	1.41	0.70	0.70	25.73
1411	6	0	5	27.5	12.0	1.0	12.5	1.0	1.44	0.71	0.72	26.31
1442	6	0	10	20.0	4.5	1.0	4.8	1.0	0.89	0.44	0.45	27.27
1457	6	0	15									32.75
1462	6	10	0	27.1	16.3	1.0	8.0	1.0	1.42	0.78	0.63	26.57
1466	6	10	5	26.0	15.0	1.0	8.0	1.0	1.35	0.74	0.61	25.23
1470	6	10	10	25.8	15.0	1.0	8.2	1.0	1.35	0.74	0.61	25.33
1474	6	10	15	27.8	16.3	1.0	11.0	1.0	1.50	0.80	0.70	27.34
1479	6	20	0	26.0	20.5	1.0	5.0	1.0	1.40	0.84	0.56	25.08
1483	6	20	5	23.3	18.0	1.0	4.0	1.0	1.24	0.75	0.49	22.68
1487	6	20	10	22.3	17.0	1.0	3.0	1.0	1.17	0.71	0.46	21.34
1491	6	20	15	21.2	16.0	1.0	3.0	1.0	1.11	0.67	0.44	20.29

* Indicates model was close to heave stop

TABLE 4.304.1 - WETTED AREA DATA

30 deg Deadrise, L/R = 0.000, Cv = 4

RUN	Trim deg	Roll deg	Yaw deg	Wetted Lengths					Wetted Areas			SKWL in	
				Keel Lk in	Stbd Chine Lcs in	Stbd Beam Bs :	Port Chine Lcp in	Port Beam Bp :	Total Atot sq.ft	Stbd As sq.ft	Port Ap sq.ft		
1644	*	-2	-10	0	49.0	49.0	1.0	49.0	1.0	3.07	1.53	1.53	48.01
1592	*	-2	0	0	48.0	48.0	1.0	48.0	1.0	3.07	1.53	1.53	47.99
1596	*	-2	0	5	48.0	48.0	1.0	48.0	1.0	3.07	1.53	1.53	47.96
1617	*	-2	10	0									48.04
1631	*	-2	20	0									48.04
1574		0	-10	0	46.0	30.0	0.8	43.0	1.0	2.60	1.09	1.51	45.49
1578		0	-10	5	47.0	30.0	0.7	47.0	1.0	2.50	0.96	1.53	45.91
1582		0	-10	10	46.3	38.0	0.4	46.3	1.0	2.12	0.59	1.53	45.54
1586		0	-10	15	41.0	41.0	0.0	10.0	1.0	0.92	0.00	0.92	39.78
1515		0	0	0	46.0	46.0	1.0	46.0	1.0	3.06	1.53	1.53	45.61
1531		0	0	5	46.3	46.3	1.0	46.3	1.0	3.06	1.53	1.53	45.89
1542		0	10	0	46.0	46.0	1.0	46.0	1.0	3.06	1.53	1.53	45.48
1546		0	10	5	46.2	46.2	1.0	46.2	1.0	3.06	1.53	1.53	45.74
1556		0	20	0	46.0	46.0	1.0	35.0	0.6	2.39	1.53	0.86	45.21
1560		0	20	5	46.2	46.2	1.0	46.2	1.0	3.06	1.53	1.53	45.61
1564		0	20	10	46.3	46.3	1.0	46.3	1.0	3.06	1.53	1.53	45.82
1568		0	20	15	47.0	47.0	1.0	47.0	1.0	3.07	1.53	1.53	46.14
1377		3	-10	0	39.1	9.0	1.0	24.0	1.0	2.01	0.87	1.14	38.54
1381		3	-10	5									38.66
1385		3	-10	10	39.8	0.0	0.6	26.8	1.0	1.63	0.43	1.20	39.36
1389		3	-10	15	30.0	0.0	0.0	11.0	1.0	0.74	0.00	0.74	23.64
1306		3	0	0	39.3	15.0	1.0	15.0	1.0	1.96	0.98	0.98	40.04
1312		3	0	5									40.27
1317		3	0	10									41.32
1322		3	0	10	40.8	14.0	1.0	23.0	1.0	2.14	0.99	1.15	41.27
1321		3	0	15	43.0	17.0	1.0	31.0	1.0	2.40	1.08	1.32	43.21

* Indicates model was close to heave stop

TABLE 4.304.2 - WETTED AREA DATA

30 deg Deadrise, L/R = 0.000, Cv = 4

RUN	Trim deg	Roll deg	Yaw deg	Wetted Lengths					Wetted Areas			SKWL in
				Keel Lk in	Stbd Chine Lcs in	Stbd Beam Bs :	Port Chine Lcp in	Port Beam Bp :	Total Atot sq.ft	Stbd As sq.ft	Port Ap sq.ft	
1327	3	10	0	39.1	24.0	1.0	8.0	1.0	1.99	1.14	0.85	39.78
1331	3	10	5									39.31
1335	3	10	10	40.0	23.0	1.0	14.0	1.0	2.11	1.14	0.97	40.19
1339	3	10	15	42.2	30.5	1.0	25.0	1.0	2.51	1.30	1.21	42.76
1340	3	10	15	42.4	30.0	1.0	25.0	1.0	2.51	1.29	1.21	42.76
1345	3	20	0	37.3	28.3	1.0	0.0	1.0	1.85	1.18	0.67	38.34
1362	3	20	5	41.2	25.0	1.0	0.0	0.8	1.79	1.19	0.60	35.29
1366	3	20	10	35.3	25.0	1.0	0.0	1.0	1.72	1.09	0.64	34.68
1372	3	20	15	36.2	26.0	1.0	4.5	1.0	1.85	1.12	0.73	35.05
1497	6	-10	0	19.5	0.0	1.0	8.5	1.0	0.86	0.35	0.51	19.30
1501	6	-10	5	20.2	0.0	1.0	9.5	1.0	0.90	0.36	0.54	19.97
1505	6	-10	10	20.3	0.0	0.8	10.0	1.0	0.84	0.29	0.55	19.97
1509	6	-10	15	22.3	0.0	0.8	12.0	1.0	0.94	0.32	0.62	22.46
1408	6	0	0	20.0	5.0	1.0	4.5	1.0	0.89	0.45	0.44	19.04
1412	6	0	5	20.2	4.5	1.0	4.8	1.0	0.90	0.45	0.45	19.13
1439	6	0	5									18.46
1443	6	0	10	20.4	4.0	1.0	5.5	1.0	0.91	0.44	0.47	18.75
1458	6	0	15	21.5	2.0	1.0	7.0	1.0	0.94	0.42	0.51	21.62
1463	6	10	0	19.0	8.3	1.0	0.0	1.0	0.84	0.49	0.34	19.01
1467	6	10	5	19.2	8.0	1.0	0.0	1.0	0.84	0.49	0.35	18.82
1471	6	10	10	19.2	8.0	1.0	0.0	1.0	0.84	0.49	0.35	18.82
1475	6	10	15	19.3	8.2	1.0	2.0	1.0	0.88	0.50	0.38	19.01
1480	6	20	0	17.5	12.0	1.0	0.9	1.0	0.86	0.53	0.33	16.94
1484	6	20	5	14.9	10.3	1.0	0.0	0.8	0.67	0.45	0.22	15.13
1488	6	20	10	15.3	10.0	1.0	0.0	0.8	0.68	0.46	0.22	14.74
1492	6	20	15	15.3	10.0	1.0	0.0	0.6	0.62	0.46	0.17	14.74

* Indicates model was close to heave stop

TABLE 4.311.1 - WETTED AREA DATA
 30 deg Deadrise, L/R = 0.117, Cv = 1.5

RUN	Trim deg	Roll deg	Yaw deg	Wetted Lengths					Wetted Areas			SKWL in	
				Keel Lk in	Stbd Chine Lcs in	Stbd Beam Bs :	Port Chine Lcp in	Port Beam Bp :	Total Atot sq.ft	Stbd As sq.ft	Port Ap sq.ft		
564 *	0	-10	-15										47.07
561	0	-10	-10										46.38
556	0	-10	-5	46.3	35.0	0.7	44.5	1.0	2.53	1.00	1.52	46.10	
528	0	-10	0	46.3	37.0	0.6	44.0	1.0	2.40	0.88	1.52	45.95	
532	0	-10	5	46.3	37.0	0.7	44.0	1.0	2.54	1.02	1.52	46.02	
536	0	-10	10	47.0	38.0	0.6	47.0	1.0	2.42	0.89	1.53	46.23	
550	0	-10	15	47.0	38.0	0.6	47.0	1.0	2.42	0.89	1.53	46.66	
464 *	0	0	-15	47.3	47.3	1.0	47.3	1.0	3.07	1.53	1.53	46.87	
461	0	0	-10	46.3	46.3	0.9	46.3	1.0	2.91	1.38	1.53	46.38	
457	0	0	-5	46.3	46.3	0.9	46.3	1.0	2.91	1.38	1.53	46.14	
78	0	0	0	46.3	28.0	0.9	28.0	0.9	2.40	1.20	1.20	45.88	
443	0	0	0	46.3	46.3	0.9	46.3	0.9	2.76	1.38	1.38	46.00	
448	0	0	5	46.3	46.3	1.0	46.3	1.0	3.06	1.53	1.53	46.04	
452	0	0	10	46.3	46.3	1.0	46.3	1.0	3.06	1.53	1.53	46.28	
455 *	0	0	15	47.3	47.3	1.0	47.3	1.0	3.07	1.53	1.53	46.97	
496	0	10	-15	47.0	47.0	1.0	40.0	0.5	2.28	1.53	0.75	46.61	
492	0	10	-10	46.5	46.5	1.0	42.0	0.6	2.44	1.53	0.91	46.30	
488	0	10	-5	47.0	45.0	1.0	40.0	0.7	2.58	1.53	1.05	46.08	
467	0	10	0	46.3	46.3	1.0	37.0	0.7	2.55	1.53	1.02	45.95	
479	0	10	5	46.3	44.5	1.0	35.0	0.8	2.67	1.52	1.15	46.02	
483	0	10	10	46.3	46.3	1.0	46.3	0.9	2.91	1.53	1.38	46.25	
486 *	0	10	15	47.0	47.0	1.0	47.0	1.0	3.07	1.53	1.53	46.90	
523	0	20	-15	47.0	47.0	1.0	0.0	0.3	1.79	1.53	0.25	46.69	
519	0	20	-10	46.0	45.5	1.0	42.0	0.4	2.13	1.53	0.60	46.15	
515	0	20	-5	46.5	45.0	1.0	40.0	0.5	2.28	1.53	0.75	45.98	
501	0	20	0	46.0	44.0	1.0	40.0	0.4	2.11	1.52	0.59	45.86	
505	0	20	5	46.0	45.0	1.0	40.0	0.4	2.12	1.52	0.59	45.92	
509	0	20	10	46.3	45.0	1.0	35.0	0.7	2.53	1.53	1.00	46.18	
513	0	20	15	47.0	47.0	1.0	30.0	0.7	2.50	1.53	0.96	46.74	
276	3	-10	-15	43.7	30.0	1.0	29.5	1.0	2.63	1.32	1.31	43.55	
272	3	-10	-10	43.1	26.5	1.0	32.0	1.0	2.59	1.25	1.34	43.30	
267	3	-10	-5	42.8	24.0	0.8	32.0	1.0	2.30	0.96	1.33	43.11	
246	3	-10	0	42.5	26.0	0.8	32.5	1.0	2.32	0.99	1.33	43.05	
249	3	-10	5									43.18	
251	3	-10	5	42.9	29.0	0.7	33.0	1.0	2.25	0.90	1.35	43.15	
253	3	-10	5									43.14	
257	3	-10	10	43.3	0.0	0.0	35.0	1.0	1.38	0.00	1.38	43.57	
261	3	-10	15	43.9	0.0	0.5	37.0	1.0	1.82	0.40	1.42	43.97	
129	3	0	-15	44.3	36.0	1.0	20.0	1.0	2.58	1.41	1.16	43.77	
124	3	0	-10	43.3	32.0	1.0	17.0	1.0	2.43	1.34	1.09	43.14	
120	3	0	-5	43.0	30.5	1.0	19.0	1.0	2.43	1.31	1.12	42.94	
81	3	0	0	43.2	28.5	1.0	28.5	1.0	2.57	1.29	1.29	42.91	
87	3	0	5	43.0	29.0	1.0	29.0	1.0	2.58	1.29	1.29	42.89	
107	3	0	5	43.0	29.0	1.0	30.0	1.0	2.59	1.29	1.31	43.01	
111	3	0	10	43.5	27.0	1.0	32.0	1.0	2.61	1.27	1.34	43.33	
115	3	0	15	44.2	18.0	1.0	35.5	1.0	2.53	1.12	1.41	43.94	
135	3	0	15	44.3	20.0	1.0	36.0	1.0	2.58	1.16	1.41	44.10	

* Indicates model was close to heave stop

TABLE 4.311.2 - WETTED AREA DATA

30 deg Deadrise, L/R = 0.117, Cv = 1.5

RUN	Trim deg	Roll deg	Yaw deg	Wetted Lengths					Wetted Areas			SKWL in
				Keel Lk in	Stbd Chine Lcs in	Stbd Beam Bs :	Port Chine Lcp in	Port Beam Bp :	Total Atot sq.ft	Stbd As sq.ft	Port Ap sq.ft	
188	3	10	-15	42.9	35.0	1.0	0.0	0.5	1.76	1.38	0.39	42.91
184	3	10	-10	43.2	35.0	1.0	0.0	1.0	2.16	1.38	0.78	43.12
180	3	10	-5	42.8	33.6	1.0	0.0	1.0	2.13	1.36	0.77	42.80
138	3	10	0	42.5	33.5	1.0	0.0	0.9	2.04	1.35	0.69	42.63
144	3	10	5									42.83
146	3	10	5	42.8	34.0	1.0	8.0	1.0	2.28	1.36	0.92	42.82
150	3	10	10	43.2	34.0	1.0	27.0	1.0	2.63	1.37	1.26	43.16
170	3	10	15									43.98
173	3	10	15									43.94
174	3	10	15	44.0	36.5	1.0	31.0	1.0	2.75	1.42	1.34	43.94
240	3	20	-15	42.7	37.7	1.0	0.0	0.4	1.72	1.41	0.31	43.15
235	3	20	-10									42.99
231	3	20	-5	41.8	36.2	1.0	0.0	0.6	1.83	1.38	0.45	42.91
197	3	20	0	41.7	36.0	1.0	0.0	0.6	1.82	1.37	0.45	42.73
204	3	20	5	41.7	36.0	1.0	0.0	0.8	1.98	1.37	0.60	42.88
210	3	20	10	42.2	37.0	1.0	0.0	1.0	2.16	1.39	0.76	43.20
214	3	20	15	43.5	39.0	1.0	26.0	1.0	2.69	1.44	1.25	43.98
437	6	-10	-15	35.9	20.5	1.0	24.7	1.0	2.11	1.02	1.09	37.02
433	6	-10	-10	35.8	20.0	1.0	25.5	1.0	2.11	1.01	1.10	36.90
429	6	-10	-5	35.3	18.5	1.0	25.5	1.0	2.07	0.97	1.10	36.65
404	6	-10	0	35.1	16.0	1.0	25.5	1.0	2.01	0.92	1.09	35.78
408	6	-10	5	35.6	5.0	1.0	26.0	1.0	1.84	0.73	1.11	36.32
412	6	-10	10	36.5	5.0	1.0	27.0	1.0	1.89	0.75	1.14	37.06
425	6	-10	15	37.8	7.0	1.0	29.0	1.0	2.01	0.81	1.20	38.94
325	6	0	-15	36.9	24.9	1.0	16.0	1.0	2.07	1.11	0.96	37.63
318	6	0	-10	35.8	22.7	1.0	15.5	1.0	1.98	1.06	0.93	36.78
312	6	0	-5									36.54
290	6	0	0	35.3	21.0	1.0	22.5	1.0	2.06	1.02	1.04	35.98
294	6	0	5	36.0	21.5	1.0	21.6	1.0	2.08	1.04	1.04	36.49
299	6	0	10	36.6	16.0	1.0	23.0	1.0	2.03	0.95	1.08	37.34
303	6	0	15	37.9	16.7	1.0	25.4	1.0	2.13	0.99	1.14	38.46
309	6	0	15	38.1	17.0	1.0	25.0	1.0	2.13	0.99	1.14	38.84
365	6	10	-15	36.6	28.0	1.0	8.0	1.0	1.97	1.16	0.81	37.25
360	6	10	-10	35.8	25.3	1.0	7.0	1.0	1.87	1.10	0.77	36.71
347	6	10	-5	34.9	26.0	1.0	8.0	1.0	1.87	1.10	0.77	36.67
330	6	10	0	34.9	26.0	1.0	10.5	1.0	1.92	1.10	0.82	36.35
335	6	10	5	35.2	26.0	1.0	18.0	1.0	2.06	1.10	0.96	36.63
339	6	10	10	35.9	26.0	1.0	19.0	1.0	2.11	1.11	0.99	37.25
343	6	10	15	36.9	27.8	1.0	22.0	1.0	2.23	1.16	1.06	38.53
398	6	20	-15	35.7	30.5	1.0	0.0	0.5	1.51	1.19	0.32	36.82
394	6	20	-10	34.4	29.4	1.0	0.0	0.9	1.70	1.15	0.56	36.20
390	6	20	-5	34.1	29.0	1.0	0.0	0.9	1.69	1.13	0.55	35.77
373	6	20	0	33.6	28.5	1.0	0.0	0.9	1.66	1.12	0.55	35.88
377	6	20	5	33.9	28.7	1.0	5.0	1.0	1.83	1.13	0.70	36.03
382	6	20	10	34.8	29.3	1.0	17.0	1.0	2.09	1.15	0.94	36.65
386	6	20	15	35.2	30.5	1.0	19.5	1.0	2.17	1.18	0.99	37.27

* Indicates model was close to heave stop

TABLE 4.313.1 - WETTED AREA DATA

30 deg Deadrise, L/R = 0.117, Cv = 3

RUN	Trim deg	Roll deg	Yaw deg	Wetted Lengths					Wetted Areas			SKWL in	
				Keel Lk in	Stbd Chine Lcs in	Stbd Beam Bs :	Port Chine Lcp in	Port Beam Bp :	Total Atot sq.ft	Stbd As sq.ft	Port Ap sq.ft		
562 *	0	-10	-10										47.14
558	0	-10	-5										46.04
529	0	-10	0	46.0	46.0	0.8	43.0	1.0	2.74	1.22	1.51		45.71
533	0	-10	5	46.3	30.0	0.8	44.0	1.0	2.61	1.09	1.52		45.93
537	0	-10	10	46.8	37.0	0.7	46.8	1.0	2.56	1.03	1.53		46.53
552	0	-10	15	45.3	45.0	0.4	37.0	1.0	2.05	0.61	1.44		45.16
462 *	0	0	-10	47.3	47.3	1.0	47.3	1.0	3.07	1.53	1.53		46.84
458	0	0	-5	46.3	46.3	1.0	46.3	1.0	3.06	1.53	1.53		45.93
444	0	0	0	46.0	46.0	1.0	46.0	1.0	3.06	1.53	1.53		45.76
449	0	0	5	46.3	46.3	1.0	46.3	1.0	3.06	1.53	1.53		45.95
453 *	0	0	10	47.3	47.3	1.0	47.3	1.0	3.07	1.53	1.53		47.24
497	0	10	-15	44.8	31.5	1.0	0.0	0.0	1.36	1.36	0.00		43.56
493	0	10	-10	46.5	45.3	1.0	40.0	0.6	2.43	1.53	0.90		46.17
489	0	10	-5	46.3	44.0	1.0	40.0	0.6	2.42	1.52	0.89		45.84
468	0	10	0	46.0	46.0	1.0	28.0	0.7	2.46	1.53	0.93		45.72
480	0	10	5	46.0	45.0	1.0	46.0	1.0	3.05	1.52	1.53		45.98
484	0	10	10	47.0	47.0	1.0	47.0	1.0	3.07	1.53	1.53		46.65
524	0	20	-15	45.0	42.0	1.0	0.0	0.0	1.49	1.49	0.00		45.12
520	0	20	-10	46.3	45.0	1.0	0.0	0.0	1.53	1.53	0.00		45.95
516	0	20	-5	46.0	45.0	1.0	45.0	0.2	1.83	1.52	0.30		45.71
502	0	20	0	46.0	43.5	1.0	40.0	0.4	2.11	1.52	0.59		45.63
506	0	20	5	46.0	45.0	1.0	25.0	0.8	2.55	1.52	1.02		45.80
510	0	20	10	46.5	46.0	1.0	46.0	1.0	3.06	1.53	1.53		46.32
277	3	-10	-15	42.8	26.0	1.0	29.0	1.0	2.52	1.24	1.29		42.95
273	3	-10	-10	41.7	20.0	1.0	27.7	1.0	2.36	1.11	1.25		41.87
269	3	-10	-5	41.2	17.5	1.0	27.8	1.0	2.30	1.06	1.24		41.58
247	3	-10	0	41.0	15.0	1.0	28.0	1.0	2.25	1.01	1.24		41.53
254	3	-10	5	41.1	0.0	0.8	28.0	1.0	1.83	0.59	1.24		41.60
258	3	-10	10	42.0	0.0	0.2	31.0	1.0	1.46	0.15	1.30		42.47
262	3	-10	15	32.4	0.0	0.2	14.0	1.0	0.95	0.12	0.84		35.61
130	3	0	-15	43.4	33.0	1.0	19.0	1.0	2.48	1.36	1.13		43.06
125	3	0	-10	42.2	27.0	1.0	16.0	1.0	2.29	1.24	1.05		41.76
121	3	0	-5	41.3	24.0	1.0	19.0	1.0	2.27	1.18	1.09		41.34
82	3	0	0	41.0	22.0	1.0	22.0	1.0	2.27	1.14	1.14		41.16
88	3	0	5	40.8	22.0	1.0	22.0	1.0	2.27	1.13	1.13		41.11
101	3	0	5	41.3	20.0	1.0	23.0	1.0	2.27	1.11	1.16		41.37
105	3	0	5	41.1	20.0	1.0	21.0	1.0	2.22	1.10	1.12		41.43
112	3	0	10	42.3	21.0	1.0	27.0	1.0	2.39	1.14	1.25		42.48
116	3	0	15	44.4	30.0	1.0	35.0	1.0	2.73	1.33	1.40		43.99
132	3	0	15	44.8	34.0	1.0	37.0	1.0	2.83	1.39	1.43		44.39

* Indicates model was close to heave stop

TABLE 4.313.2 - WETTED AREA DATA

30 deg Deadrise, L/R = 0.117, CV = 3

RUN	Trim deg	Roll deg	Yaw deg	Wetted Lengths					Wetted Areas			SKWL in
				Keel Lk in	Stbd Chine Lcs in	Stbd Beam Bs :	Port Chine Lcp in	Port Beam Bp :	Total Atot sq.ft	Stbd As sq.ft	Port Ap sq.ft	
191	3	10	-15	35.0	18.0	1.0	0.0	0.5	1.27	0.96	0.32	36.44
185	3	10	-10	41.3	31.0	1.0	0.0	0.9	1.96	1.29	0.67	41.55
181	3	10	-5	40.9	29.0	1.0	0.0	1.0	1.99	1.25	0.74	41.19
141	3	10	0	40.2	28.0	1.0	17.0	1.0	2.26	1.22	1.03	40.83
147	3	10	5	40.3	27.5	1.0	15.0	1.0	2.22	1.22	1.00	40.92
151	3	10	10	41.3	29.0	1.0	19.0	1.0	2.35	1.26	1.09	41.58
175	3	10	15	43.6	34.8	1.0	29.0	1.0	2.69	1.39	1.30	43.47
241	3	20	-15	33.8	25.5	1.0	0.0	0.0	1.07	1.07	0.00	37.54
236	3	20	-10	38.3	31.0	1.0	0.0	0.5	1.59	1.24	0.35	40.47
232	3	20	-5	39.2	32.0	1.0	0.0	0.7	1.77	1.27	0.50	41.28
200	3	20	0	39.3	32.0	1.0	0.0	0.8	1.84	1.27	0.57	41.03
206	3	20	5	38.7	30.0	1.0	0.0	1.0	1.93	1.23	0.70	40.61
211	3	20	10	38.3	30.3	1.0	0.0	1.0	1.92	1.23	0.69	40.48
215	3	20	15	39.1	31.0	1.0	0.0	1.0	1.96	1.25	0.71	40.75
216	3	20	15	39.0	31.3	1.0	0.0	1.0	1.96	1.26	0.70	40.85
438	6	-10	-15	26.0	9.5	1.0	14.7	1.0	1.38	0.64	0.73	28.05
434	6	-10	-10	25.9	9.0	1.0	17.0	1.0	1.40	0.63	0.77	27.71
430	6	-10	-5	26.3	9.0	1.0	16.0	1.0	1.40	0.64	0.76	28.69
405	6	-10	0	27.9	9.5	1.0	17.5	1.0	1.49	0.68	0.82	28.86
409	6	-10	5	28.9	9.0	1.0	18.6	1.0	1.54	0.68	0.86	30.07
413	6	-10	10	29.6	2.0	1.0	19.6	1.0	1.46	0.57	0.89	30.62
426	6	-10	15	32.3	3.0	1.0	22.0	1.0	1.62	0.64	0.98	33.59
326	6	0	-15	30.8	16.9	1.0	11.0	1.0	1.62	0.86	0.75	31.75
319	6	0	-10	28.8	14.1	1.0	12.3	1.0	1.52	0.77	0.74	29.61
315	6	0	-5	27.8	13.0	1.0	13.0	1.0	1.47	0.74	0.74	28.92
292	6	0	0	27.2	12.0	1.0	12.0	1.0	1.42	0.71	0.71	28.00
296	6	0	5	27.6	12.2	1.0	13.0	1.0	1.45	0.72	0.73	29.05
300	6	0	10	29.6	13.0	1.0	15.0	1.0	1.57	0.77	0.81	30.55
304	6	0	15	32.8	13.0	1.0	18.1	1.0	1.75	0.83	0.92	33.04
366	6	10	-15	31.3	21.2	1.0	4.0	1.0	1.59	0.95	0.64	31.96
361	6	10	-10	29.2	19.0	1.0	5.0	0.0	0.87	0.87	0.00	30.20
363	6	10	-10	29.0	19.0	1.0	4.5	1.0	1.47	0.87	0.60	29.99
357	6	10	-5	27.9	17.4	1.0	9.8	1.0	1.50	0.82	0.68	29.31
331	6	10	0	26.2	15.8	1.0	9.0	1.0	1.39	0.76	0.64	27.93
336	6	10	5	25.8	15.0	1.0	8.0	1.0	1.35	0.74	0.61	27.65
340	6	10	10	25.7	14.9	1.0	8.5	1.0	1.35	0.73	0.62	27.87
344	6	10	15	27.2	16.2	1.0	11.6	1.0	1.48	0.78	0.70	29.40
400	6	20	-15	25.3	20.7	1.0	0.0	0.5	1.06	0.83	0.23	27.72
395	6	20	-10	26.3	21.5	1.0	0.0	0.8	1.24	0.86	0.38	28.80
391	6	20	-5	26.8	21.5	1.0	0.0	0.9	1.31	0.87	0.44	29.20
374	6	20	0	24.5	19.8	1.0	6.0	1.0	1.35	0.80	0.55	27.57
378	6	20	5	22.9	17.2	1.0	4.5	1.0	1.22	0.72	0.49	25.74
383	6	20	10	21.0	16.0	1.0	4.0	1.0	1.12	0.67	0.45	24.50
387	6	20	15	21.2	16.0	1.0	5.0	1.0	1.14	0.67	0.47	24.12

* Indicates model was close to heave stop

TABLE 4.314.1 - WETTED AREA DATA

30 deg Deadrise, L/R = 0.117, Cv = 4

RUN	Trim deg	Roll deg	Yaw deg	Wetted Lengths					Wetted Areas			SKWL in	
				Keel Lk in	Stbd Chine Lcs in	Stbd Beam Bs :	Port Chine Lcp in	Port Beam Bp :	Total Atot sq.ft	Stbd As sq.ft	Port Ap sq.ft		
559	0	-10	-5										46.05
530	0	-10	0	46.3	46.3	0.9	43.5	1.0	2.90	1.38	1.52		45.77
534	0	-10	5	47.0	30.0	0.9	47.0	1.0	2.77	1.24	1.53		46.38
554 *	0	-10	10	47.3	39.0	0.7	47.3	1.0	2.58	1.05	1.53		47.09
553	0	-10	15	42.0	45.0	0.2	5.0	1.0	1.15	0.30	0.85		42.41
459	0	0	-5	46.3	46.3	1.0	46.3	1.0	3.06	1.53	1.53		46.05
445	0	0	0	46.0	46.0	1.0	46.0	1.0	3.06	1.53	1.53		45.72
450	0	0	5	46.3	46.3	1.0	46.3	1.0	3.06	1.53	1.53		46.11
498	0	10	-15	40.5	20.0	1.0	0.0	0.0	1.09	1.09	0.00		41.86
494	0	10	-10	46.5	45.0	1.0	42.0	0.4	2.13	1.53	0.60		46.12
490	0	10	-5	46.3	44.0	1.0	35.0	0.7	2.52	1.52	1.00		45.93
469	0	10	0	46.0	44.0	1.0	30.0	0.9	2.74	1.52	1.22		45.75
481	0	10	5	46.3	45.0	1.0	46.3	1.0	3.06	1.53	1.53		46.14
525	0	20	-15	42.3	35.0	1.0	0.0	0.0	1.37	1.37	0.00		43.23
521	0	20	-10	46.0	45.0	1.0	0.0	0.0	1.52	1.52	0.00		45.67
517	0	20	-5	46.0	45.0	1.0	45.0	0.2	1.83	1.52	0.30		45.74
503	0	20	0	46.0	43.0	1.0	40.0	0.6	2.40	1.51	0.89		45.68
507	0	20	5	46.3	45.0	1.0	45.0	1.0	3.05	1.53	1.53		45.95
278	3	-10	-15	42.5	25.5	1.0	28.0	1.0	2.49	1.22	1.27		42.72
274	3	-10	-10	40.8	17.0	1.0	25.3	1.0	2.23	1.04	1.19		40.98
270	3	-10	-5	39.7	12.5	1.0	24.6	1.0	2.10	0.94	1.16		40.27
248	3	-10	0	40.0	11.0	1.0	25.0	1.0	2.09	0.92	1.17		40.70
255	3	-10	5	40.0	0.0	0.8	25.0	1.0	1.75	0.58	1.17		40.56
259	3	-10	10	40.3	0.0	0.6	27.0	1.0	1.65	0.44	1.21		41.01
265	3	-10	15	23.2	0.0	0.3	5.0	1.0	0.63	0.13	0.51		28.85
131	3	0	-15	43.3	32.0	1.0	14.0	1.0	2.38	1.34	1.03		42.99
126	3	0	-10	41.4	25.5	1.0	14.0	1.0	2.20	1.20	1.00		41.20
122	3	0	-5	39.9	20.0	1.0	16.5	1.0	2.10	1.08	1.02		40.14
83	3	0	0	40.0	17.0	1.0	17.0	1.0	2.06	1.03	1.03		39.89
106	3	0	5	39.9	15.5	1.0	19.0	1.0	2.06	1.00	1.06		40.32
113	3	0	10	41.0	12.0	1.0	21.0	1.0	2.08	0.96	1.12		41.20
117	3	0	15	44.0	29.0	1.0	34.5	1.0	2.70	1.31	1.39		44.00
133	3	0	15	45.3	38.0	1.0	39.0	1.0	2.92	1.45	1.47		45.11

* Indicates model was close to heave stop

TABLE 4.314.2 - WETTED AREA DATA

30 deg Deadrise, L/R = 0.117, Cv = 4

RUN	Trim deg	Roll deg	Yaw deg	Wetted Lengths					Wetted Areas			SKWL in
				Keel Lk in	Stbd Chine Lcs in	Stbd Beam Bs :	Port Chine Lcp in	Port Beam Bp :	Total Atot sq.ft	Stbd As sq.ft	Port Ap sq.ft	
192	3	10	-15	28.8	10.0	1.0	0.0	0.5	0.96	0.70	0.26	32.95
193	3	10	-15	28.8	12.0	1.0	0.0	0.3	0.89	0.74	0.16	32.99
186	3	10	-10	38.7	25.0	1.0	0.0	0.8	1.71	1.15	0.56	39.37
182	3	10	-5	39.2	25.0	1.0	0.0	1.0	1.86	1.16	0.71	39.46
143	3	10	0	39.2	24.0	1.0	12.0	1.0	2.06	1.14	0.92	39.39
148	3	10	5	38.8	21.8	1.0	8.0	1.0	1.94	1.09	0.84	39.24
153	3	10	10	40.0	24.0	1.0	14.0	1.0	2.13	1.15	0.97	40.12
178	3	10	15	42.8	32.7	1.0	25.0	1.0	2.56	1.34	1.22	43.02
243	3	20	-15	24.2	15.0	1.0	0.0	0.5	0.93	0.71	0.22	31.76
238	3	20	-10	33.0	23.6	1.0	0.0	0.5	1.32	1.02	0.30	37.15
233	3	20	-5	37.7	29.5	1.0	0.0	0.7	1.68	1.20	0.48	40.07
201	3	20	0	37.3	28.5	1.0	0.0	0.9	1.79	1.18	0.61	39.25
202	3	20	0	36.9	28.5	1.0	0.0	0.9	1.77	1.17	0.60	39.16
207	3	20	5	35.3	26.0	1.0	0.0	1.0	1.74	1.10	0.64	38.44
212	3	20	10	36.0	25.0	1.0	0.0	1.0	1.75	1.10	0.65	38.40
229	3	20	15	36.5	26.5	1.0	6.0	1.0	1.90	1.13	0.77	39.12
439	6	-10	-15	19.7	1.0	1.0	8.0	1.0	0.87	0.37	0.50	21.91
435	6	-10	-10	19.8	2.0	1.0	9.0	1.0	0.91	0.39	0.52	21.66
431	6	-10	-5	19.8	0.0	0.0	9.0	1.0	0.52	0.00	0.52	21.71
406	6	-10	0	20.6	2.0	1.0	9.5	1.0	0.95	0.41	0.54	21.78
410	6	-10	5	21.2	0.0	1.0	11.0	1.0	0.96	0.38	0.58	22.29
414	6	-10	10	20.3	0.0	0.9	9.5	1.0	0.87	0.33	0.54	21.16
427	6	-10	15	20.5	0.0	0.8	10.0	1.0	0.85	0.30	0.55	22.50
327	6	0	-15	22.8	9.0	1.0	4.9	1.0	1.07	0.57	0.50	23.88
322	6	0	-10	21.0	7.0	1.0	6.0	1.0	0.99	0.51	0.49	22.28
316	6	0	-5	21.3	6.0	1.0	6.0	1.0	0.99	0.49	0.49	22.63
293	6	0	0	21.0	5.5	1.0	5.5	1.0	0.96	0.48	0.48	21.94
297	6	0	5	20.9	5.0	1.0	6.0	1.0	0.95	0.47	0.49	22.16
301	6	0	10	21.2	3.6	1.0	6.5	1.0	0.95	0.45	0.50	22.32
306	6	0	15	21.7	2.0	1.0	7.4	1.0	0.95	0.43	0.53	22.69
368	6	10	-15	24.3	14.7	1.0	0.0	0.9	1.10	0.70	0.39	25.32
362	6	10	-10	21.2	10.2	1.0	0.0	0.9	0.91	0.57	0.34	22.21
358	6	10	-5	19.8	9.5	1.0	3.0	1.0	0.94	0.53	0.41	20.87
333	6	10	0	19.9	9.0	1.0	2.0	1.0	0.92	0.52	0.40	21.59
337	6	10	5	19.9	9.0	1.0	2.0	1.0	0.92	0.52	0.40	21.78
341	6	10	10	19.9	9.0	1.0	2.7	1.0	0.93	0.52	0.41	22.23
345	6	10	15	19.8	8.9	1.0	3.9	1.0	0.95	0.52	0.43	22.84
370	6	10	15	20.5	8.9	1.0	4.0	1.0	0.97	0.53	0.44	22.32
401	6	20	-15	18.0	13.0	1.0	0.0	0.4	0.69	0.56	0.13	20.09
396	6	20	-10	20.0	15.0	1.0	0.0	0.6	0.85	0.63	0.22	22.09
392	6	20	-5	19.8	14.3	1.0	0.0	0.9	0.94	0.62	0.32	21.91
375	6	20	0	17.3	12.0	1.0	3.5	1.0	0.90	0.53	0.38	20.09
379	6	20	5	16.1	11.0	1.0	0.0	0.6	0.66	0.49	0.17	19.03
380	6	20	5	16.4	11.0	1.0	0.0	0.6	0.67	0.49	0.18	19.07
384	6	20	10	15.3	10.0	1.0	6.0	1.0	0.84	0.46	0.38	18.76
388	6	20	15	16.0	11.0	1.0	0.0	0.7	0.69	0.49	0.20	19.25

* Indicates model was close to heave stop

TABLE 4.321.1 - WETTED AREA DATA
 30 deg Deadrise, L/R = 0.234, Cv = 1.5

RUN	Trim deg	Roll deg	Yaw deg	Wetted Lengths					Wetted Areas			SKWL in
				Keel Lk in	Stbd Chine Lcs in	Stbd Beam Bs :	Port Chine Lcp in	Port Beam Bp :	Total Atot sq.ft	Stbd As sq.ft	Port Ap sq.ft	
1127	0	-10	-15	47.0	32.0	0.8	47.0	1.0	2.66	1.12	1.53	46.62
1129 *	0	-10	-15	47.3	30.0	0.8	47.3	1.0	2.64	1.10	1.53	46.83
1123	0	-10	-10	46.5	44.0	0.5	45.0	1.0	2.29	0.76	1.53	46.10
1118	0	-10	-5	46.2	42.0	0.5	43.0	1.0	2.27	0.75	1.51	45.86
1102	0	-10	0	46.0	40.0	0.6	43.0	1.0	2.40	0.89	1.51	45.77
1106	0	-10	5	46.2	38.0	0.6	43.0	1.0	2.40	0.88	1.51	45.85
1111	0	-10	10	46.5	38.0	0.6	45.0	1.0	2.41	0.88	1.53	46.09
1114	0	-10	15	47.0	44.0	0.4	46.0	1.0	2.15	0.61	1.53	46.33
1025	0	0	-15	47.0	47.0	1.0	47.0	1.0	3.07	1.53	1.53	46.59
1021	0	0	-10	46.5	46.5	0.9	46.5	1.0	2.91	1.38	1.53	46.12
1017	0	0	-5	46.3	43.5	0.9	46.3	1.0	2.90	1.37	1.53	45.93
1004	0	0	0	46.3	43.0	0.9	43.0	0.9	2.73	1.36	1.36	45.85
1008	0	0	5	46.3	46.3	0.9	46.3	0.9	2.76	1.38	1.38	45.96
1012	0	0	10	46.5	45.0	1.0	45.0	1.0	3.06	1.53	1.53	46.19
1015 *	0	0	15	47.3	47.3	1.0	47.3	1.0	3.07	1.53	1.53	46.84
1059	0	10	-15	47.0	47.0	1.0	47.0	0.1	1.69	1.53	0.15	46.43
1055	0	10	-10	46.5	46.5	1.0	43.0	0.6	2.44	1.53	0.91	45.99
1051	0	10	-5	46.5	46.5	1.0	42.0	0.7	2.59	1.53	1.06	45.84
1036	0	10	0	46.0	44.0	1.0	38.0	0.8	2.69	1.52	1.17	45.72
1040	0	10	5	46.3	44.5	1.0	35.0	0.8	2.67	1.52	1.15	45.79
1044	0	10	10									46.03
1045	0	10	10	46.5	46.5	1.0	46.5	1.0	3.07	1.53	1.53	46.07
1049	0	10	15	47.0	47.0	1.0	47.0	1.0	3.07	1.53	1.53	46.70
1097	0	20	-15	47.0	47.0	1.0	47.0	0.5	2.30	1.53	0.77	46.46
1093	0	20	-10	46.5	46.5	1.0	46.5	0.2	1.84	1.53	0.31	45.98
1088	0	20	-5	47.0	45.0	1.0	45.0	0.5	2.30	1.53	0.77	45.72
1064	0	20	0	46.0	45.0	1.0	46.0	0.5	2.29	1.52	0.76	45.63
1068	0	20	5	46.0	45.0	1.0	46.0	0.6	2.44	1.52	0.92	45.71
1071	0	20	10	46.5	46.5	1.0	46.5	0.6	2.45	1.53	0.92	45.98
1073	0	20	10	46.5	46.5	1.0	46.5	0.6	2.45	1.53	0.92	45.98
1077	0	20	15	46.5	46.5	1.0	46.5	0.9	2.91	1.53	1.38	46.44
833	3	-10	-15	43.3	30.0	1.0	29.0	1.0	2.61	1.31	1.29	43.55
829	3	-10	-10	42.8	25.5	1.0	28.0	1.0	2.50	1.23	1.27	43.13
825	3	-10	-5	42.4	24.0	0.8	31.5	1.0	2.28	0.96	1.32	42.90
801	3	-10	0	42.5	28.0	0.8	32.0	1.0	2.34	1.01	1.33	42.77
813	3	-10	5	42.8	30.0	0.8	33.0	1.0	2.39	1.04	1.35	43.06
817	3	-10	10	43.2	0.0	1.0	35.0	1.0	2.16	0.78	1.38	43.47
821	3	-10	15	44.2	0.0	0.9	38.0	1.0	2.16	0.72	1.44	44.20
698	3	0	-15	43.8	34.5	1.0	19.0	1.0	2.52	1.39	1.13	43.79
689	3	0	-10	42.6	29.0	1.0	15.0	1.0	2.32	1.28	1.04	42.78
700	3	0	-10	43.1	31.0	1.0	17.0	1.0	2.41	1.32	1.09	43.22
685	3	0	-5	42.6	29.0	1.0	15.0	1.0	2.32	1.28	1.04	42.84
705	3	0	-5	42.7	29.0	1.0	17.0	1.0	2.36	1.28	1.08	43.00
658	3	0	0	42.9	28.0	1.0	30.0	1.0	2.58	1.27	1.30	42.95
711	3	0	0	42.8	28.0	1.0	18.0	1.0	2.37	1.27	1.10	42.92
662	3	0	5	43.0	28.0	1.0	28.0	1.0	2.55	1.27	1.27	43.14
713	3	0	5	43.0	28.0	1.0	28.0	1.0	2.55	1.27	1.27	43.10
676	3	0	10	43.4	30.0	1.0	30.5	1.0	2.63	1.31	1.32	43.37
719	3	0	10	43.5	30.0	1.0	31.0	1.0	2.64	1.31	1.33	43.54

* Indicates model was close to heave stop

TABLE 4.321.2 - WETTED AREA DATA
 30 deg Deadrise, L/R = 0.234, Cv = 1.5

RUN	Trim deg	Roll deg	Yaw deg	Wetted Lengths					Wetted Areas			SKWL in
				Keel Lk in	Stbd Chine Lcs in	Stbd Beam Bs :	Port Chine Lcp in	Port Beam Bp :	Total Atot sq.ft	Stbd As sq.ft	Port Ap sq.ft	
680	3	0	15	44.3	30.0	1.0	35.0	1.0	2.73	1.33	1.40	44.23
723	3	0	15	44.5	25.0	1.0	35.0	1.0	2.66	1.25	1.40	44.36
765	3	10	-15	43.2	36.0	1.0	0.0	0.2	1.55	1.40	0.16	43.16
761	3	10	-10	42.6	34.0	1.0	4.0	1.0	2.20	1.36	0.84	42.88
757	3	10	-5	42.3	33.0	1.0	0.0	1.0	2.10	1.34	0.76	42.63
727	3	10	0	42.3	32.5	1.0	7.0	1.0	2.22	1.33	0.89	42.83
753	3	10	5	42.8	33.5	1.0	20.0	1.0	2.49	1.35	1.13	42.86
731	3	10	10	43.2	35.0	1.0	25.0	1.0	2.61	1.38	1.23	43.43
749	3	10	15	44.0	37.0	1.0	29.0	1.0	2.73	1.42	1.31	43.97
796	3	20	-15	42.9	38.0	1.0	0.0	0.0	1.42	1.42	0.00	43.18
792	3	20	-10	42.0	36.5	1.0	0.0	0.0	1.38	1.38	0.00	42.62
788	3	20	-5	41.6	36.0	1.0	0.0	0.7	1.90	1.37	0.53	42.34
772	3	20	0	41.3	35.5	1.0	0.0	0.8	1.96	1.36	0.60	42.33
776	3	20	5	41.6	35.6	1.0	0.0	1.0	2.12	1.37	0.75	42.54
780	3	20	10	42.3	37.2	1.0	6.0	1.0	2.27	1.40	0.87	43.00
784	3	20	15	43.5	39.5	1.0	26.0	1.0	2.70	1.45	1.25	43.71
995	6	-10	-15	35.3	19.5	1.0	24.0	1.0	2.06	0.99	1.07	37.00
990	6	-10	-10	34.5	18.0	1.0	24.0	1.0	2.00	0.95	1.06	36.27
991	6	-10	-10	34.5	18.0	1.0	24.0	1.0	2.00	0.95	1.06	36.34
986	6	-10	-5	34.3	17.5	1.0	24.0	1.0	1.99	0.94	1.05	36.00
960	6	-10	0									36.30
961	6	-10	0	35.0	0.0	1.0	25.0	1.0	1.71	0.63	1.08	36.24
966	6	-10	5	35.3	0.0	1.0	25.5	1.0	1.73	0.64	1.10	36.67
978	6	-10	10	36.3	0.0	1.0	27.0	1.0	1.79	0.66	1.14	37.45
982	6	-10	15	38.0	5.0	1.0	29.0	1.0	1.98	0.78	1.20	39.02
865	6	0	-15	36.0	23.0	1.0	15.5	1.0	1.99	1.06	0.93	37.27
861	6	0	-10	35.3	21.5	1.0	16.0	1.0	1.95	1.03	0.93	36.70
857	6	0	-5	35.1	21.0	1.0	18.0	1.0	1.97	1.01	0.96	36.50
840	6	0	0	35.0	21.0	1.0	21.0	1.0	2.02	1.01	1.01	36.37
845	6	0	5	35.5	22.0	1.0	22.0	1.0	2.08	1.04	1.04	36.92
849	6	0	10	36.6	16.0	1.0	23.0	1.0	2.03	0.95	1.08	37.78
853	6	0	15	38.3	17.0	1.0	26.0	1.0	2.16	1.00	1.16	39.22
924	6	10	-15	35.4	26.5	1.0	7.0	1.0	1.88	1.11	0.77	36.78
920	6	10	-10	34.3	25.5	1.0	9.0	1.0	1.86	1.08	0.78	36.18
916	6	10	-5	34.3	24.5	1.0	8.0	1.0	1.82	1.06	0.76	35.79
870	6	10	0									36.30
871	6	10	0	34.3	24.5	1.0	13.0	1.0	1.91	1.06	0.85	36.23
889	6	10	5	35.2	25.0	1.0	18.0	1.0	2.05	1.08	0.96	36.20
893	6	10	10									36.78
894	6	10	10	35.5	26.0	1.0	19.8	1.0	2.11	1.11	1.00	36.77
899	6	10	15	37.2	28.0	1.0	22.0	1.0	2.24	1.17	1.07	38.22
956	6	20	-15	34.0	29.0	1.0	0.0	0.2	1.25	1.13	0.12	36.53
952	6	20	-10	33.0	27.4	1.0	0.0	1.0	1.68	1.09	0.60	35.77
947	6	20	-5	32.6	27.4	1.0	0.0	1.0	1.67	1.08	0.59	35.43
929	6	20	0	32.9	27.6	1.0	4.0	1.0	1.76	1.09	0.67	35.55
933	6	20	5	33.3	28.0	1.0	9.0	1.0	1.87	1.10	0.76	36.07
937	6	20	10	33.9	28.7	1.0	18.0	1.0	2.06	1.13	0.94	36.49
941	6	20	15									37.35
942	6	20	15	34.8	30.0	1.0	19.5	1.0	2.14	1.16	0.98	37.15

* Indicates model was close to heave stop

TABLE 4.323.1 - WETTED AREA DATA

30 deg Deadrise, L/R = 0.234, Cv = 3

RUN	Trim deg	Roll deg	Yaw deg	Wetted Lengths					Wetted Areas			SKWL in
				Keel Lk in	Stbd Chine Lcs in	Stbd Beam Bs :	Port Chine Lcp in	Port Beam Bp :	Total Atot sq.ft	Stbd As sq.ft	Port Ap sq.ft	
1128 *	0	-10	-15	47.3	47.3	1.0	47.3	1.0	3.07	1.53	1.53	46.94
1124	0	-10	-10	47.0	47.0	1.0	47.0	1.0	3.07	1.53	1.53	46.46
1120	0	-10	-5	46.0	38.0	0.9	42.0	1.0	2.82	1.32	1.50	45.68
1103	0	-10	0	46.0	34.0	0.9	41.0	1.0	2.77	1.27	1.50	45.55
1108	0	-10	5	46.0	39.0	0.8	42.5	1.0	2.69	1.18	1.51	45.71
1112	0	-10	10	47.0	47.0	0.9	47.0	1.0	2.92	1.38	1.53	46.80
1115	0	-10	15	43.5	0.0	0.5	26.0	1.0	1.64	0.39	1.25	43.45
1026	0	0	-15	44.8	34.0	1.0	0.0	0.0	1.39	1.39	0.00	44.59
1022	0	0	-10	46.5	46.5	1.0	46.5	1.0	3.07	1.53	1.53	46.32
1018	0	0	-5	46.0	46.0	1.0	46.0	1.0	3.06	1.53	1.53	45.73
1005	0	0	0	46.0	46.0	0.9	46.0	1.0	2.91	1.38	1.53	45.66
1009	0	0	5	46.0	46.0	0.9	46.0	1.0	2.91	1.38	1.53	45.83
1013 *	0	0	10	47.3	47.3	1.0	47.3	1.0	3.07	1.53	1.53	46.93
1060	0	10	-15	43.1	32.0	1.0	43.1	0.0	1.34	1.34	0.00	43.13
1056	0	10	-10	46.0	44.0	1.0	45.0	0.3	1.98	1.52	0.46	45.76
1052	0	10	-5	46.0	46.0	1.0	40.0	0.6	2.42	1.53	0.89	45.58
1037	0	10	0	46.0	42.5	1.0	30.0	0.8	2.59	1.51	1.09	45.51
1041	0	10	5	46.0	43.5	1.0	46.0	1.0	3.05	1.52	1.53	45.70
1046	0	10	10	47.0	47.0	1.0	47.0	1.0	3.07	1.53	1.53	46.58
1098	0	20	-15	45.5	43.0	1.0	45.5	0.0	1.51	1.51	0.00	45.36
1094	0	20	-10	46.0	44.0	1.0	46.0	0.0	1.52	1.52	0.00	45.65
1089	0	20	-5	46.0	46.0	1.0	46.0	0.2	1.84	1.53	0.31	45.49
1065	0	20	0	46.0	44.0	1.0	46.0	0.5	2.28	1.52	0.76	45.43
1069	0	20	5	46.0	44.0	1.0	46.0	1.0	3.05	1.52	1.53	45.56
1074	0	20	10	46.5	46.5	1.0	46.5	0.6	2.45	1.53	0.92	46.12
1078 *	0	20	15	46.5	46.5	1.0	46.5	1.0	3.07	1.53	1.53	46.85
834	3	-10	-15	42.8	27.0	1.0	29.0	1.0	2.54	1.25	1.29	43.32
830	3	-10	-10	41.5	22.0	1.0	27.7	1.0	2.39	1.15	1.24	42.47
826	3	-10	-5	41.0	18.0	1.0	27.0	1.0	2.29	1.07	1.22	41.85
802	3	-10	0	41.1	9.0	1.0	28.5	1.0	2.15	0.90	1.25	41.53
814	3	-10	5	41.0	15.0	0.7	28.0	1.0	1.95	0.71	1.24	41.52
818	3	-10	10	42.0	0.0	1.0	31.0	1.0	2.06	0.76	1.30	42.64
822	3	-10	15	33.0	0.0	0.5	12.5	1.0	1.12	0.30	0.82	35.08
697	3	0	-15	42.8	31.0	1.0	15.0	1.0	2.36	1.32	1.04	43.19
690	3	0	-10	42.3	28.5	1.0	15.0	1.0	2.30	1.27	1.03	42.75
701	3	0	-10	41.6	27.0	1.0	14.0	1.0	2.24	1.23	1.00	42.38
706	3	0	-5	40.9	24.0	1.0	21.0	1.0	2.29	1.17	1.12	41.67
659	3	0	0	42.0	26.0	1.0	24.0	1.0	2.41	1.22	1.19	42.24
710	3	0	0	40.5	21.0	1.0	21.0	1.0	2.22	1.11	1.11	41.31
663	3	0	5	41.8	25.0	1.0	25.0	1.0	2.41	1.20	1.20	42.27
714	3	0	5	41.3	21.0	1.0	22.0	1.0	2.27	1.12	1.14	41.62
677	3	0	10	42.3	24.0	1.0	27.0	1.0	2.44	1.20	1.25	42.79
720	3	0	10	42.7	25.0	1.0	27.8	1.0	2.48	1.22	1.27	42.93
724	3	0	15	45.0	37.0	1.0	37.0	1.0	2.88	1.44	1.44	44.89

* Indicates model was close to heave stop

TABLE 4.323.2 - WETTED AREA DATA
30 deg Deadrise, L/R = 0.234, Cv = 3

RUN	Trim deg	Roll deg	Yaw deg	Wetted Lengths					Wetted Areas			SKWL in
				Keel Lk in	Stbd Chine Lcs in	Stbd Beam Bs :	Port Chine Lcp in	Port Beam Bp :	Total Atot sq.ft	Stbd As sq.ft	Port Ap sq.ft	
766	3	10	-15	35.1	19.7	1.0	0.0	0.1	1.05	0.99	0.06	36.95
762	3	10	-10	41.5	31.5	1.0	0.0	0.5	1.68	1.30	0.37	42.11
758	3	10	-5	40.7	29.0	1.0	6.0	1.0	2.09	1.25	0.84	41.32
728	3	10	0	39.6	27.0	1.0	11.0	1.0	2.11	1.20	0.91	40.92
754	3	10	5	40.2	27.0	1.0	13.0	1.0	2.17	1.21	0.96	40.93
732	3	10	10	41.3	29.0	1.0	18.0	1.0	2.33	1.26	1.07	42.01
744	3	10	10	41.3	29.5	1.0	18.0	1.0	2.34	1.27	1.07	41.85
750	3	10	15	43.9	36.0	1.0	28.0	1.0	2.70	1.41	1.29	43.71
797	3	20	-15	34.7	27.0	1.0	0.0	0.0	1.11	1.11	0.00	37.84
793	3	20	-10	38.2	31.2	1.0	0.0	0.0	1.24	1.24	0.00	40.49
789	3	20	-5	39.3	32.5	1.0	0.0	0.9	1.92	1.28	0.64	41.05
773	3	20	0	38.7	31.4	1.0	0.0	1.0	1.95	1.25	0.70	40.71
777	3	20	5	38.0	30.0	1.0	0.0	1.0	1.90	1.22	0.69	39.93
781	3	20	10	38.1	30.0	1.0	9.0	1.0	2.07	1.22	0.85	40.05
785	3	20	15	38.9	31.0	1.0	8.0	1.0	2.10	1.25	0.85	40.41
996	6	-10	-15	26.2	9.5	1.0	15.0	1.0	1.39	0.64	0.74	28.65
992	6	-10	-10	25.5	8.0	1.0	14.6	1.0	1.33	0.60	0.72	27.83
987	6	-10	-5	25.2	7.0	1.0	14.0	1.0	1.29	0.58	0.71	27.29
963	6	-10	0	27.8	8.5	1.0	16.8	1.0	1.46	0.66	0.81	29.90
967	6	-10	5	28.0	5.0	1.0	17.0	1.0	1.41	0.60	0.81	29.99
979	6	-10	10	27.8	0.0	0.9	17.2	1.0	1.26	0.45	0.81	30.04
983	6	-10	15	33.3	0.0	1.0	23.2	1.0	1.62	0.60	1.02	34.72
866	6	0	-15	30.0	16.0	1.0	11.0	1.0	1.57	0.83	0.74	31.82
862	6	0	-10	27.0	13.5	1.0	12.0	1.0	1.44	0.73	0.70	29.27
858	6	0	-5	26.0	11.3	1.0	11.0	1.0	1.34	0.67	0.67	28.18
842	6	0	0	25.7	11.0	1.0	11.0	1.0	1.33	0.66	0.66	27.86
846	6	0	5	26.5	11.9	1.0	11.9	1.0	1.39	0.69	0.69	29.17
850	6	0	10	28.7	11.8	1.0	14.0	1.0	1.50	0.73	0.77	30.35
854	6	0	15	33.5	14.0	1.0	19.3	1.0	1.81	0.86	0.95	34.98
925	6	10	-15	29.3	20.0	1.0	5.0	1.0	1.51	0.89	0.62	31.77
921	6	10	-10	26.3	16.8	1.0	6.0	1.0	1.36	0.78	0.58	28.67
917	6	10	-5	24.2	14.0	1.0	7.0	1.0	1.25	0.69	0.56	26.59
882	6	10	0									25.63
883	6	10	0									26.27
884	6	10	0									26.30
885	6	10	0									25.59
886	6	10	0	24.8	14.0	1.0	7.0	1.0	1.27	0.70	0.57	26.30
890	6	10	5	25.0	14.0	1.0	12.5	1.0	1.38	0.70	0.68	26.24
895	6	10	10									26.40
896	6	10	10									26.73
900	6	10	15	27.2	15.8	1.0	10.5	1.0	1.46	0.78	0.68	28.79
957	6	20	-15	25.8	21.0	1.0	0.0	0.6	1.12	0.84	0.28	29.84
953	6	20	-10	25.0	20.0	1.0	0.0	0.8	1.17	0.81	0.36	28.65
948	6	20	-5	23.2	18.5	1.0	4.0	1.0	1.24	0.75	0.49	26.94
930	6	20	0	21.5	16.7	1.0	5.0	1.0	1.17	0.69	0.48	25.18
934	6	20	5	20.3	15.6	1.0	3.0	1.0	1.07	0.65	0.42	24.09
939	6	20	10	20.1	15.0	1.0	3.0	1.0	1.05	0.63	0.42	23.88
944	6	20	15	20.4	15.0	1.0	4.0	1.0	1.08	0.64	0.44	24.19

* Indicates model was close to heave stop

TABLE 4.324.1 - WETTED AREA DATA

30 deg Deadrise, L/R = 0.234, Cv = 4

RUN	Trim deg	Roll deg	Yaw deg	Wetted Lengths					Wetted Areas			SKWL in
				Keel Lk in	Stbd Chine Lcs in	Stbd Beam Bs :	Port Chine Lcp in	Port Beam Bp :	Total Atot sq.ft	Stbd As sq.ft	Port Ap sq.ft	
1125 *	0	-10	-10	47.0	47.0	1.0	47.0	1.0	3.07	1.53	1.53	46.99
1121	0	-10	-5	46.0	32.0	0.9	42.0	1.0	2.75	1.25	1.50	45.81
1104	0	-10	0	34.0	35.0	0.9	41.0	1.0	2.45	1.11	1.34	45.61
1109	0	-10	5	46.5	35.0	0.9	45.0	1.0	2.82	1.29	1.53	46.12
1116	0	-10	15	41.5	15.0	0.9	0.0	0.8	1.52	0.92	0.60	41.62
1027	0	0	-15	41.3	13.0	1.0	0.0	0.0	0.98	0.98	0.00	42.34
1023 *	0	0	-10	47.2	47.2	1.0	47.2	0.9	2.92	1.53	1.38	47.02
1019	0	0	-5	46.0	46.0	1.0	46.0	1.0	3.06	1.53	1.53	45.87
1006	0	0	0	46.0	40.0	0.9	40.0	1.0	2.82	1.34	1.49	45.69
1010	0	0	5	46.0	46.0	0.9	46.0	1.0	2.91	1.38	1.53	45.88
1061	0	10	-15	40.7	20.0	1.0	0.0	0.0	1.10	1.10	0.00	41.60
1057	0	10	-10	46.0	46.0	1.0	46.0	0.2	1.84	1.53	0.31	45.77
1053	0	10	-5	46.2	46.2	1.0	43.0	0.7	2.59	1.53	1.06	45.81
1038	0	10	0	46.0	43.0	1.0	46.0	0.9	2.89	1.51	1.38	45.59
1042	0	10	5	46.0	43.0	1.0	46.0	1.0	3.04	1.51	1.53	45.66
1047 *	0	10	10	47.3	47.3	1.0	47.3	1.0	3.07	1.53	1.53	46.93
1099	0	20	-15	42.5	35.0	1.0	0.0	0.0	1.37	1.37	0.00	43.53
1095	0	20	-10	45.0	44.0	1.0	45.0	0.0	1.51	1.51	0.00	45.44
1091	0	20	-5	45.5	44.0	1.0	45.5	0.1	1.67	1.51	0.15	45.52
1066	0	20	0	46.0	43.0	1.0	46.0	0.5	2.28	1.51	0.76	45.47
1070	0	20	5	46.0	44.0	1.0	46.0	1.0	3.05	1.52	1.53	45.60
1075	0	20	10	46.5	46.5	1.0	46.5	0.6	2.45	1.53	0.92	45.98
835	3	-10	-15	42.5	28.0	1.0	28.5	1.0	2.54	1.27	1.27	43.39
831	3	-10	-10	41.2	21.0	1.0	27.0	1.0	2.35	1.12	1.23	42.32
827	3	-10	-5	40.3	17.0	1.0	27.0	1.0	2.24	1.03	1.21	41.61
803	3	-10	0	40.6	14.0	1.0	27.0	1.0	2.20	0.99	1.22	41.35
815	3	-10	5	40.5	0.0	1.0	26.0	1.0	1.93	0.73	1.20	41.33
819	3	-10	10	41.2	0.0	0.6	29.0	1.0	1.70	0.45	1.26	42.00
823	3	-10	15	21.3	0.0	0.5	3.0	1.0	0.63	0.19	0.44	26.42
696	3	0	-15	42.7	31.0	1.0	15.0	1.0	2.36	1.32	1.04	43.26
702	3	0	-10	41.3	26.0	1.0	15.0	1.0	2.23	1.21	1.02	42.28
703	3	0	-10	41.3	27.0	1.0	13.0	1.0	2.21	1.23	0.98	42.30
707	3	0	-5	40.7	22.0	1.0	17.0	1.0	2.17	1.13	1.04	41.40
660	3	0	0	41.4	26.0	1.0	24.0	1.0	2.39	1.21	1.18	42.22
709	3	0	0	39.2	20.0	1.0	18.0	1.0	2.10	1.07	1.03	41.07
664	3	0	5	42.0	24.0	1.0	24.5	1.0	2.39	1.19	1.20	42.21
715	3	0	5	40.3	19.0	1.0	19.5	1.0	2.15	1.07	1.08	41.14
678	3	0	10	42.0	22.0	1.0	26.0	1.0	2.38	1.16	1.22	42.41
721	3	0	10	42.0	24.0	1.0	25.0	1.0	2.40	1.19	1.21	42.62
767	3	10	-15	31.3	13.5	1.0	0.0	0.1	0.87	0.81	0.06	34.39
768	3	10	-15	30.7	13.3	1.0	0.0	0.1	0.85	0.79	0.06	34.12

* Indicates model was close to heave stop

TABLE 4.324.2 - WETTED AREA DATA
30 deg Deadrise, L/R = 0.234, Cv = 4

RUN	Trim deg	Roll deg	Yaw deg	Wetted Lengths					Wetted Areas			SKWL in
				Keel Lk in	Stbd Chine Lcs in	Stbd Beam Bs :	Port Chine Lcp in	Port Beam Bp :	Total Atot sq.ft	Stbd As sq.ft	Port Ap sq.ft	
763	3	10	-10	40.5	29.0	1.0	0.0	0.3	1.47	1.25	0.22	41.45
759	3	10	-5	40.2	28.0	1.0	6.0	1.0	2.06	1.22	0.83	41.15
729	3	10	0	38.6	24.5	1.0	13.0	1.0	2.07	1.14	0.93	40.43
755	3	10	5	38.8	24.5	1.0	12.0	1.0	2.06	1.14	0.92	40.19
746	3	10	10	39.0	26.5	1.0	15.0	1.0	2.15	1.18	0.97	40.87
747	3	10	10	40.2	25.5	1.0	15.0	1.0	2.18	1.18	1.00	40.82
751	3	10	15	43.1	34.0	1.0	25.0	1.0	2.59	1.37	1.23	43.17
798	3	20	-15	29.5	21.0	1.0	0.0	0.0	0.91	0.91	0.00	35.25
794	3	20	-10	36.1	29.0	1.0	0.0	0.0	1.17	1.17	0.00	39.20
790	3	20	-5	38.8	32.0	1.0	0.0	0.9	1.89	1.26	0.63	40.95
774	3	20	0	37.2	28.5	1.0	0.0	1.0	1.85	1.18	0.67	39.58
778	3	20	5	36.3	27.0	1.0	0.0	1.0	1.79	1.14	0.66	38.62
782	3	20	10	35.3	26.5	1.0	0.0	1.0	1.75	1.11	0.64	38.29
786	3	20	15	35.3	26.5	1.0	7.0	1.0	1.88	1.11	0.76	38.43
997	6	-10	-15	22.5	5.6	1.0	11.0	1.0	1.11	0.51	0.60	24.95
993	6	-10	-10	21.9	4.0	1.0	10.5	1.0	1.05	0.47	0.58	24.01
988	6	-10	-5	21.4	3.0	1.0	10.0	1.0	1.01	0.44	0.57	23.97
964	6	-10	0	23.5	4.2	1.0	12.7	1.0	1.15	0.50	0.65	25.89
968	6	-10	5	22.1	0.0	0.9	11.5	1.0	0.97	0.36	0.61	24.48
998	6	-10	5	22.4	0.0	1.0	11.5	1.0	1.02	0.40	0.61	24.62
980	6	-10	10	18.8	0.0	0.7	8.5	1.0	0.73	0.24	0.49	21.05
999	6	-10	10	19.8	0.0	0.7	9.3	1.0	0.78	0.25	0.53	22.13
984	6	-10	15	20.9	0.0	0.7	10.8	1.0	0.84	0.26	0.57	23.12
867	6	0	-15	26.3	12.5	1.0	8.5	1.0	1.33	0.70	0.63	28.70
863	6	0	-10	23.4	9.2	1.0	8.1	1.0	1.16	0.59	0.57	25.83
859	6	0	-5									24.73
843	6	0	0	21.5	6.8	1.0	6.8	1.0	1.02	0.51	0.51	24.00
847	6	0	5	20.7	5.0	1.0	6.0	1.0	0.95	0.46	0.48	23.18
851	6	0	10	20.8	4.2	1.0	7.0	1.0	0.95	0.45	0.50	23.66
855	6	0	15	19.3	0.0	1.0	5.0	1.0	0.79	0.35	0.44	21.46
926	6	10	-15	27.2	17.6	1.0	3.0	1.0	1.35	0.81	0.55	29.86
922	6	10	-10	23.2	8.5	1.0	4.0	1.0	1.06	0.57	0.49	25.66
918	6	10	-5	21.2	10.8	1.0	4.0	1.0	1.03	0.58	0.46	23.30
887	6	10	0	19.8	14.2	1.0	2.5	1.0	1.02	0.61	0.40	21.96
891	6	10	5	20.2	9.5	1.0	3.2	1.0	0.96	0.54	0.42	22.15
897	6	10	10	19.9	13.5	1.0	3.0	1.0	1.02	0.60	0.41	21.85
901	6	10	15									22.27
902	6	10	15									22.40
903	6	10	15									22.25
914	6	10	15	20.2	8.5	1.0	3.8	1.0	0.95	0.52	0.43	22.47
958	6	20	-15	13.0	8.8	1.0	0.0	0.4	0.49	0.39	0.09	16.57
954	6	20	-10	22.2	18.0	1.0	0.0	0.8	1.05	0.73	0.32	26.38
949	6	20	-5	20.0	15.0	1.0	3.0	1.0	1.05	0.63	0.42	23.80
950	6	20	-5	20.0	15.0	1.0	0.0	1.0	0.99	0.63	0.36	23.89
931	6	20	0	17.3	12.6	1.0	3.0	1.0	0.91	0.54	0.37	21.19
935	6	20	5	16.2	11.5	1.0	2.0	1.0	0.83	0.50	0.33	20.25
940	6	20	10	15.0	6.0	1.0	3.0	1.0	0.70	0.38	0.32	19.65
945	6	20	15	14.8	10.8	1.0	0.0	0.8	0.68	0.46	0.21	19.64

* Indicates model was close to heave stop

TABLE 5.300.1 - STABILITY DATA IN WIND AXES WITHOUT AIR TARES

30 deg Deadrise, L/R = 0.000, Cv = 0

RUN	Trim deg	Roll deg	Yaw deg	Speed fps	X lb	Y lb	Z lb	K lb-ft	M lb-ft	N lb-ft	Heave in	TD in
1641	-2	-10	0	0.00	0.08	0.03	11.49	0.19	1.13	0.02	1.89	1.41
1645	-2	-10	5	0.00	0.06	0.04	11.49	0.10	1.09	0.02	1.88	1.42
1648	-2	-10	10	0.00	0.05	0.00	11.49	0.03	1.06	0.02	1.88	1.42
1651	-2	-10	15	0.00	0.08	0.05	11.49	-0.18	0.99	0.03	1.87	1.43
1588	-2	0	0	0.00	0.07	0.07	11.49	-0.03	1.17	0.03	1.91	1.45
1593	-2	0	5	0.00	0.04	0.02	11.49	-0.10	1.03	0.01	1.84	1.52
1607	-2	0	10	0.00	0.06	0.06	11.49	-0.19	1.06	0.03	1.87	1.49
1610	-2	0	15	0.00	0.07	0.06	11.49	-0.32	1.02	0.04	1.84	1.52
1614	-2	10	0	0.00	0.06	0.03	11.49	-0.22	1.16	0.02	1.87	1.43
1618	-2	10	5	0.00	0.08	0.07	11.49	-0.31	1.01	0.03	1.88	1.42
1621	-2	10	10	0.00	0.05	0.07	11.49	-0.40	0.93	0.02	1.88	1.42
1624	-2	10	15	0.00	0.08	0.08	11.49	-0.49	0.85	0.02	1.86	1.44
1628	-2	20	0	0.00	0.07	0.05	11.49	-0.33	0.75	0.02	2.01	1.10
1632	-2	20	5	0.00	0.06	0.12	11.49	-0.42	0.62	0.02	1.95	1.16
1635	-2	20	10	0.00	0.07	0.08	11.49	-0.46	0.59	0.02	1.95	1.16
1638	-2	20	15	0.00	0.06	0.08	11.49	-0.48	0.50	0.02	1.97	1.14
1571	0	-10	0	0.00	0.05	0.05	11.49	0.24	-3.30	0.01	2.01	2.08
1575	0	-10	5	0.00	0.06	0.08	11.49	0.53	-3.29	0.03	1.99	2.10
1579	0	-10	10	0.00	0.05	0.07	11.49	0.81	-3.25	0.02	2.00	2.09
1583	0	-10	15	0.00	0.06	0.07	11.49	1.13	-3.25	0.02	1.99	2.10
1511	0	0	0	0.00	0.04	0.07	11.49	0.02	-3.17	0.02	1.84	2.31
1527	0	0	5	0.00	0.06	0.07	11.49	0.29	-3.07	0.02	1.97	2.18
1532	0	0	10	0.00	0.05	0.07	11.49	0.56	-3.07	0.02	1.97	2.18
1535	0	0	15	0.00	0.06	0.14	11.49	0.85	-3.07	0.05	1.94	2.21
1539	0	10	0	0.00	-0.04	0.01	11.49	-0.21	-3.50	-0.33	1.99	2.10
1543	0	10	5	0.00	0.06	0.09	11.49	0.09	-3.39	0.02	2.00	2.09
1547	0	10	10	0.00	0.06	0.08	11.49	0.39	-3.39	0.02	2.00	2.09
1550	0	10	15	0.00	0.05	0.08	11.49	0.68	-3.39	0.03	1.98	2.11
1553	0	20	0	0.00	0.05	0.09	11.49	-0.31	-3.47	0.02	2.09	1.81
1557	0	20	5	0.00	0.05	0.09	11.49	-0.03	-3.61	0.01	2.05	1.85
1561	0	20	10	0.00	0.04	0.04	11.49	0.31	-3.50	0.02	2.12	1.78
1565	0	20	15	0.00	0.07	0.10	11.49	0.61	-3.51	0.03	2.10	1.80
1374	3	-10	0	0.00	0.04	0.07	11.49	0.29	-8.48	0.01	2.26	3.00
1379	3	-10	5	0.00	0.04	0.09	11.49	1.02	-8.35	0.03	2.28	2.98
1382	3	-10	10	0.00	0.05	0.09	11.49	1.74	-8.20	0.04	2.28	2.98
1386	3	-10	15	0.00	0.05	0.11	11.49	2.48	-8.10	0.04	2.26	3.00
1301	3	0	0	0.00	0.03	0.03	11.49	0.05	-8.27	0.01	2.06	3.26
1307	3	0	0	0.00	0.04	0.07	11.49	0.05	-8.41	0.02	2.06	3.26
1689	3	0	0	0.00	0.04	0.09	11.49	0.07	-8.56	0.11	2.20	3.12
1309	3	0	5	0.00	0.04	0.07	11.49	0.78	-8.37	0.04	2.07	3.25
1313	3	0	10	0.00	0.04	0.05	11.49	1.49	-8.16	0.05	2.08	3.24
1318	3	0	15	0.00	0.05	0.06	11.49	2.26	-8.15	0.03	2.07	3.25

* Indicates model was close to heave stop

TABLE 5.300.2 - STABILITY DATA IN WIND AXES WITHOUT AIR TARES

30 deg Deadrise, L/R = 0.000, Cv = 0

RUN	Trim deg	Roll deg	Yaw deg	Speed fps	X lb	Y lb	Z lb	K lb-ft	M lb-ft	N lb-ft	Heave in	TD in
1324	3	10	0	0.00	0.04	0.07	11.49	-0.15	-8.35	0.01	2.13	3.13
1328	3	10	5	0.00	0.05	0.08	11.49	0.58	-8.34	0.03	2.12	3.14
1332	3	10	10	0.00	0.06	0.08	11.49	1.29	-8.25	0.04	2.12	3.14
1336	3	10	15	0.00	0.05	0.09	11.49	1.99	-8.02	0.04	2.14	3.12
1342	3	20	0	0.00	0.04	0.08	11.49	-0.30	-8.60	0.01	2.15	2.92
1359	3	20	5	0.00	0.05	0.06	11.49	0.46	-8.83	0.02	2.29	2.78
1363	3	20	10	0.00	0.06	0.10	11.49	1.22	-8.57	0.03	2.34	2.73
1367	3	20	15	0.00	0.06	0.11	11.49	1.97	-8.47	0.03	2.32	2.75
1494	6	-10	0	0.00	0.05	0.06	11.49	0.31	-11.65	0.00	2.58	3.84
1498	6	-10	5	0.00	0.04	0.09	11.49	1.33	-11.67	0.03	2.55	3.87
1502	6	-10	10	0.00	0.06	0.11	11.49	2.31	-11.48	0.03	2.54	3.88
1506	6	-10	15	0.00	0.05	0.08	11.49	3.31	-11.23	0.03	2.57	3.85
1405	6	0	0	0.00	0.04	0.07	11.49	0.08	-11.49	0.00	2.68	3.80
1438	6	0	0	0.00	0.02	0.02	11.49	0.09	-11.96	0.00	2.67	3.81
1409	6	0	5	0.00	0.04	0.07	11.49	1.10	-11.68	0.02	2.65	3.83
1440	6	0	10	0.00	0.06	0.08	11.49	2.05	-11.23	0.04	2.76	3.72
1444	6	0	15	0.00	0.05	0.08	11.49	3.06	-11.08	0.02	2.77	3.71
1455	6	0	15	0.00	0.05	0.04	11.49	3.05	-11.03	0.02	2.72	3.76
1460	6	10	0	0.00	0.04	0.06	11.49	-0.13	-11.78	0.02	2.57	3.85
1464	6	10	5	0.00	0.05	0.11	11.49	0.88	-11.60	0.03	2.59	3.83
1468	6	10	10	0.00	0.05	0.10	11.49	1.91	-11.57	0.04	2.57	3.85
1472	6	10	15	0.00	0.06	0.12	11.49	2.97	-11.61	0.04	2.54	3.88
1477	6	20	0	0.00	0.06	0.11	11.49	-0.29	-11.78	0.04	2.60	3.63
1481	6	20	5	0.00	0.05	0.10	11.49	0.73	-11.81	0.02	2.60	3.63
1485	6	20	10	0.00	0.07	0.09	11.49	1.73	-11.45	0.03	2.63	3.60
1489	6	20	15	0.00	0.07	0.11	11.49	2.77	-11.51	0.03	2.60	3.63

* Indicates model was close to heave stop

TABLE 5.301.1 - STABILITY DATA IN WIND AXES WITHOUT AIR TARES

30 deg Deadrise, L/R = 0.000, Cv = 1.5

RUN	Trim deg	Roll deg	Yaw deg	Speed fps	X lb	Y lb	Z lb	K lb-ft	M lb-ft	N lb-ft	Heave in	TD in
1642	-2	-10	0	7.36	1.54	0.29	11.49	0.17	4.38	0.23	1.54	1.76
1646	-2	-10	5	7.35	1.76	1.37	11.49	-0.33	4.59	2.29	1.47	1.83
1649	-2	-10	10	7.35	2.45	3.26	11.49	-0.90	5.06	4.99	1.27	2.03
1652	-2	-10	15	7.34	4.08	6.37	11.49	-1.84	5.90	8.81	0.98	2.32
1589	-2	0	0	7.35	1.48	-0.05	11.49	0.03	4.30	0.00	1.57	1.79
1594	-2	0	5	7.35	1.69	0.94	11.49	-0.43	4.33	1.96	1.49	1.87
1608	-2	0	10	7.45	2.57	3.35	11.49	-1.08	5.00	4.59	1.22	2.14
1611 *	-2	0	15	7.34	4.45	7.08	11.49	-1.82	5.48	8.97	0.82	2.54
1615	-2	10	0	7.34	1.57	-0.01	11.49	-0.15	4.11	-0.44	1.53	1.77
1619	-2	10	5	7.34	1.72	0.93	11.49	-0.67	4.13	1.47	1.44	1.86
1622	-2	10	10	7.34	2.49	3.12	11.49	-1.40	4.95	4.22	1.21	2.09
1625 *	-2	10	15	7.32	4.88	7.63	11.49	-2.55	7.02	8.82	0.70	2.60
1629	-2	20	0	7.46	1.40	-0.17	11.49	-0.19	3.89	-0.53	1.69	1.42
1633	-2	20	5	7.38	1.65	0.85	11.49	-0.80	3.92	1.06	1.57	1.54
1636	-2	20	10	7.37	2.51	2.79	11.49	-1.59	4.40	3.68	1.28	1.83
1639 *	-2	20	15	7.34	4.69	6.66	11.49	-2.67	6.25	9.03	0.71	2.40
1572	0	-10	0	7.36	1.21	0.35	11.49	0.25	0.43	0.17	1.81	2.28
1576	0	-10	5	7.35	1.41	1.03	11.49	0.18	0.61	1.29	1.76	2.33
1580	0	-10	10	7.34	1.97	2.71	11.49	-0.04	1.07	2.71	1.63	2.46
1584	0	-10	15	7.34	3.33	5.69	11.49	-0.63	2.17	5.13	1.35	2.74
1512	0	0	0	7.35	1.21	-0.28	11.49	0.12	0.62	0.01	1.69	2.46
1528	0	0	5	7.38	1.34	0.83	11.49	0.01	0.70	1.14	1.75	2.40
1533	0	0	10	7.36	2.00	2.70	11.49	-0.25	1.47	2.36	1.57	2.58
1536	0	0	15	7.40	3.66	6.50	11.49	-0.51	2.08	4.45	1.23	2.92
1540	0	10	0	7.35	1.09	-0.17	11.49	-0.11	0.22	-0.52	1.82	2.27
1544	0	10	5	7.35	1.31	0.84	11.49	-0.26	0.53	1.02	1.77	2.32
1548	0	10	10	7.34	1.98	2.72	11.49	-0.62	1.37	2.47	1.60	2.49
1551	0	10	15	7.32	3.53	5.99	11.49	-1.24	3.09	4.20	1.24	2.85
1554	0	20	0	7.34	1.17	0.08	11.49	-0.24	0.13	-0.27	1.92	1.98
1558	0	20	5	7.38	1.24	0.65	11.49	-0.36	0.30	0.68	1.87	2.03
1562	0	20	10	7.36	1.84	2.45	11.49	-0.79	1.05	2.17	1.67	2.23
1566	0	20	15	7.36	3.50	5.66	11.49	-1.57	3.08	4.59	1.27	2.63
1375	3	-10	0	7.45	1.16	0.11	11.49	0.40	-5.38	0.20	2.27	2.99
1378	3	-10	5	7.38	1.31	1.24	11.49	0.79	-4.90	0.21	2.24	3.02
1383	3	-10	10	7.36	1.93	3.04	11.49	1.02	-3.96	-0.08	2.11	3.15
1387	3	-10	15	7.34	3.00	5.43	11.49	1.05	-2.89	-0.20	1.96	3.30
1302	3	0	0	7.32	1.13	0.22	11.49	0.09	-5.46	0.00	2.00	3.32
1303	3	0	0	7.31	1.18	0.28	11.49	0.09	-5.48	0.02	1.97	3.35
1308	3	0	0	7.31	1.15	0.05	11.49	0.12	-5.52	0.01	1.98	3.34
1310	3	0	5	7.34	1.31	1.12	11.49	0.60	-5.24	0.23	1.98	3.34
1314	3	0	10	7.35	1.83	2.72	11.49	0.88	-4.48	0.11	1.88	3.44
1319	3	0	15	7.35	3.23	5.92	11.49	0.94	-2.95	-0.21	1.62	3.70

* Indicates model was close to heave stop

TABLE 5.301.2 - STABILITY DATA IN WIND AXES WITHOUT AIR TARES

30 deg Deadrise, L/R = 0.000, Cv = 1.5

RUN	Trim deg	Roll deg	Yaw deg	Speed fps	X lb	Y lb	Z lb	K lb-ft	M lb-ft	N lb-ft	Heave in	TD in
1325	3	10	0	7.33	1.14	0.22	11.49	-0.16	-5.35	-0.18	2.09	3.17
1329	3	10	5	7.34	1.23	0.79	11.49	0.32	-5.27	-0.09	2.05	3.21
1333	3	10	10	7.33	1.77	2.54	11.49	0.56	-4.66	-0.05	1.91	3.35
1337	3	10	15	7.33	3.02	5.46	11.49	0.62	-3.42	-0.22	1.69	3.57
1343	3	20	0	7.34	1.19	0.15	11.49	-0.28	-5.22	-0.20	2.13	2.94
1360	3	20	5	7.45	1.24	0.78	11.49	0.15	-5.24	-0.30	2.29	2.78
1364	3	20	10	7.35	1.65	2.05	11.49	0.41	-4.63	-0.49	2.16	2.91
1368	3	20	15	7.34	2.76	4.75	11.49	0.15	-2.92	-0.81	1.90	3.17
1370	3	20	15	7.43	2.82	4.77	11.49	0.15	-2.81	-0.85	1.89	3.18
1495	6	-10	0	7.44	1.65	0.15	11.49	0.44	-9.36	0.19	2.64	3.78
1499	6	-10	5	7.37	1.76	1.23	11.49	1.18	-8.85	-0.67	2.61	3.81
1503	6	-10	10	7.35	2.31	3.02	11.49	1.61	-8.00	-2.04	2.55	3.87
1507	6	-10	15	7.35	3.59	6.11	11.49	1.84	-6.94	-4.35	2.36	4.06
1406	6	0	0	7.34	1.52	-0.08	11.49	0.16	-9.60	0.03	2.73	3.75
1410	6	0	5	7.43	1.79	1.13	11.49	0.97	-9.42	-0.74	2.71	3.77
1441	6	0	10	7.40	2.15	2.68	11.49	1.53	-8.55	-1.84	2.75	3.73
1456	6	0	15	7.45	3.29	5.29	11.49	1.84	-7.54	-3.76	2.51	3.97
1461	6	10	0	7.38	1.61	0.09	11.49	-0.13	-9.41	-0.19	2.66	3.76
1465	6	10	5	7.36	1.71	1.10	11.49	0.68	-9.25	-0.95	2.68	3.74
1469	6	10	10	7.35	2.19	2.82	11.49	1.32	-8.86	-2.04	2.59	3.83
1473	6	10	15	7.34	3.27	5.37	11.49	1.59	-7.86	-3.59	2.41	4.01
1478	6	20	0	7.46	1.64	0.04	11.49	-0.29	-9.08	-0.03	2.71	3.52
1482	6	20	5	7.38	1.75	1.48	11.49	0.36	-9.01	-1.14	2.68	3.55
1486	6	20	10	7.37	2.18	2.88	11.49	0.94	-8.25	-2.58	2.63	3.60

* Indicates model was close to heave stop

TABLE 5.303.1 - STABILITY DATA IN WIND AXES WITHOUT AIR TARES

30 deg Deadrise, L/R = 0.000, Cv = 3

RUN	Trim deg	Roll deg	Yaw deg	Speed fps	X lb	Y lb	Z lb	K lb-ft	M lb-ft	N lb-ft	Heave in	TD in
1643	-2	-10	0	14.72	5.71	1.14	11.49	0.32	-0.04	1.72	1.39	1.91
1647	-2	-10	5	14.71	7.15	6.42	11.49	-0.20	0.98	11.25	1.08	2.22
1650 *	-2	-10	10	14.67	11.20	17.66	11.49	-1.10	2.47	22.41	0.74	2.56
1590	-2	0	0	14.71	5.52	-0.21	11.49	0.09	-0.60	-0.57	1.42	1.94
1595	-2	0	5	14.71	6.88	5.15	11.49	-0.49	0.38	8.93	1.11	2.25
1609 *	-2	0	10	14.74	11.22	18.03	11.49	-1.27	2.57	20.35	0.71	2.65
1616	-2	10	0	14.71	5.61	-1.57	11.49	-0.21	0.08	-3.15	1.36	1.94
1620	-2	10	5	14.71	6.61	3.60	11.49	-0.74	0.46	5.66	1.08	2.22
1623 *	-2	10	10	14.67	10.91	16.68	11.49	-1.46	2.07	17.13	0.72	2.58
1630	-2	20	0	14.79	5.70	-1.60	11.49	-0.31	2.12	-4.70	1.51	1.60
1634	-2	20	5	14.72	7.56	2.99	11.49	-1.29	3.44	2.31	1.10	2.01
1637 *	-2	20	10	14.69	11.34	14.32	11.49	-2.51	6.01	13.37	0.72	2.39
1573	0	-10	0	14.72	3.20	0.02	11.49	0.26	1.52	0.92	2.04	2.05
1577	0	-10	5	14.72	4.37	4.11	11.49	-0.12	2.22	3.34	1.93	2.16
1581	0	-10	10	14.71	6.93	11.73	11.49	-0.67	3.01	7.23	1.76	2.33
1585	0	-10	15	14.69	8.13	14.52	11.49	-1.27	4.65	7.29	2.31	1.78
1513	0	0	0	14.72	3.17	-0.03	11.49	0.05	2.49	0.02	1.91	2.24
1530	0	0	5	14.74	4.20	3.79	11.49	-0.24	3.42	3.77	1.88	2.27
1534	0	0	10	14.69	8.38	14.22	11.49	-1.10	5.46	5.68	1.24	2.91
1541	0	10	0	14.71	3.15	-0.07	11.49	-0.13	1.18	-0.88	2.04	2.05
1545	0	10	5	14.71	4.18	3.82	11.49	-0.48	3.86	3.34	1.85	2.24
1549	0	10	10	14.69	8.23	13.70	11.49	-1.42	6.76	6.74	1.24	2.85
1555	0	20	0	14.79	3.32	0.09	11.49	-0.25	0.42	-0.95	2.17	1.73
1559	0	20	5	14.74	4.02	3.75	11.49	-0.60	2.76	2.06	1.91	1.99
1563	0	20	10	14.71	8.10	13.42	11.49	-1.50	5.31	10.28	1.41	2.49
1567	0	20	15	14.67	13.23	23.40	11.49	-4.05	13.58	11.43	1.28	2.62
1376	3	-10	0	14.85	2.52	0.25	11.49	0.44	-4.12	0.96	2.69	2.57
1380	3	-10	5	14.79	3.03	3.21	11.49	0.69	-2.78	0.19	2.65	2.61
1668	3	-10	5	14.79	3.08	3.01	11.49	0.74	-2.89	0.23	2.59	2.67
1384	3	-10	10	14.77	5.37	10.47	11.49	0.23	0.56	-2.40	2.42	2.84
1388	3	-10	15	14.77	3.43	5.79	11.49	2.48	-7.45	-4.48	3.53	1.73
1305	3	0	0	14.77	2.38	0.37	11.49	0.07	-4.80	0.06	2.46	2.86
1654	3	0	0	14.72	2.40	-0.32	11.49	0.49	-4.89	0.04	2.59	2.73
1311	3	0	5	14.77	3.00	3.18	11.49	0.59	-4.07	0.13	2.41	2.91
1655	3	0	5	14.72	3.09	3.12	11.49	0.84	-4.16	0.23	2.54	2.78
1316	3	0	10	14.74	5.35	10.24	11.49	0.31	-0.95	-1.43	2.20	3.12
1656	3	0	10	14.72	5.50	10.20	11.49	0.60	-0.69	-0.91	2.28	3.04
1320	3	0	15	14.71	11.99	25.83	11.49	-1.50	6.53	-2.81	1.65	3.67
1657	3	0	15	14.67	12.61	26.97	11.49	-1.51	6.81	-1.61	1.65	3.67

* Indicates model was close to heave stop

TABLE 5.303.2 - STABILITY DATA IN WIND AXES WITHOUT AIR TARES

30 deg Deadrise, L/R = 0.000, Cv = 3

RUN	Trim deg	Roll deg	Yaw deg	Speed fps	X lb	Y lb	Z lb	K lb-ft	M lb-ft	N lb-ft	Heave in	TD in
1326	3	10	0	14.74	2.52	-0.25	11.49	-0.21	-4.34	-0.79	2.51	2.75
1660	3	10	0	14.74	2.58	-0.10	11.49	-0.09	-4.29	-0.87	2.62	2.64
1330	3	10	5	14.74	2.78	2.98	11.49	0.21	-4.40	-0.96	2.48	2.78
1659	3	10	5	14.74	2.72	2.33	11.49	0.31	-4.41	-1.06	2.58	2.68
1334	3	10	10	14.72	4.47	8.31	11.49	0.28	-2.86	-1.58	2.33	2.93
1661	3	10	10	14.72	4.53	7.90	11.49	0.61	-2.72	-1.45	2.47	2.79
1338	3	10	15	14.71	9.33	19.60	11.49	-0.96	2.64	-2.41	1.97	3.29
1662	3	10	15	14.69	10.23	21.20	11.49	-1.25	4.06	-1.99	1.96	3.30
1344	3	20	0	14.76	2.49	0.09	11.49	-0.36	-3.55	-1.02	2.56	2.51
1664	3	20	0	14.74	2.58	-0.03	11.49	-0.47	-3.55	-1.24	2.69	2.38
1361	3	20	5	14.77	2.65	2.24	11.49	-0.09	-3.39	-1.96	2.77	2.30
1665	3	20	5	14.74	2.74	2.35	11.49	0.04	-3.20	-2.01	2.68	2.39
1365	3	20	10	14.77	3.62	5.98	11.49	0.10	-3.70	-3.77	2.83	2.24
1666	3	20	10	14.72	3.73	6.22	11.49	0.18	-3.41	-3.67	2.73	2.34
1369	3	20	15	14.74	6.46	12.84	11.49	-0.25	-2.60	-6.44	2.69	2.38
1371	3	20	15	14.81	6.44	12.81	11.49	-0.26	-2.65	-6.59	2.70	2.37
1667	3	20	15	14.71	6.61	13.02	11.49	-0.11	-2.13	-6.11	2.61	2.46
1496	6	-10	0	14.79	2.14	0.09	11.49	0.46	-9.50	0.35	3.64	2.78
1500	6	-10	5	14.74	2.66	2.65	11.49	1.09	-8.20	-1.91	3.50	2.92
1504	6	-10	10	14.72	4.08	7.51	11.49	1.10	-7.25	-7.17	3.41	3.01
1508	6	-10	15	14.71	8.92	18.74	11.49	0.09	-3.63	-15.26	2.89	3.53
1407	6	0	0	14.76	2.08	-0.17	11.49	0.16	-10.09	0.08	3.79	2.69
1411	6	0	5	14.81	2.58	2.64	11.49	0.96	-9.83	-2.37	3.73	2.75
1442	6	0	10	14.76	3.70	6.32	11.49	1.33	-8.48	-5.16	3.63	2.85
1457	6	0	15	14.77	7.59	15.38	11.49	0.53	-5.52	-12.14	3.04	3.44
1462	6	10	0	14.74	2.19	-0.28	11.49	-0.08	-9.76	-0.45	3.64	2.78
1466	6	10	5	14.74	2.36	2.68	11.49	0.64	-10.47	-2.97	3.78	2.64
1470	6	10	10	14.72	3.36	5.66	11.49	1.38	-10.64	-6.31	3.77	2.65
1474	6	10	15	14.71	5.64	10.83	11.49	1.62	-9.82	-10.73	3.56	2.86
1479	6	20	0	14.81	2.28	0.18	11.49	-0.38	-8.22	-0.55	3.61	2.62
1483	6	20	5	14.76	2.33	2.41	11.49	0.33	-9.80	-2.91	3.86	2.37
1487	6	20	10	14.74	2.79	4.31	11.49	1.23	-11.04	-5.88	4.00	2.23
1491	6	20	15	14.77	3.88	6.63	11.49	1.98	-11.64	-9.44	4.11	2.12

* Indicates model was close to heave stop

TABLE 5.304.1 - STABILITY DATA IN WIND AXES WITHOUT AIR TARES

30 deg Deadrise, L/R = 0.000, Cv = 4

RUN	Trim deg	Roll deg	Yaw deg	Speed fps	X lb	Y lb	Z lb	K lb-ft	M lb-ft	N lb-ft	Heave in	TD in
1644	* -2	-10	0	19.62	11.14	1.85	11.49	0.57	-3.15	3.25	0.68	2.62
1592	* -2	0	0	19.59	10.74	-0.83	11.49	0.16	-5.27	-1.43	0.70	2.66
1596	* -2	0	5	19.59	12.67	10.77	11.49	-0.58	-3.16	20.29	0.73	2.63
1617	* -2	10	0	19.62	11.20	-2.79	11.49	-0.32	-2.74	-6.14	0.65	2.65
1631	* -2	20	0	19.65	10.90	-3.21	11.49	-0.51	0.18	-10.43	0.66	2.45
1574	0	-10	0	19.65	5.69	0.03	11.49	0.08	5.30	1.34	1.93	2.16
1578	0	-10	5	19.62	8.83	7.49	11.49	-0.58	5.89	7.36	1.60	2.49
1582	0	-10	10	19.62	11.35	19.33	11.49	-1.28	5.24	12.94	1.89	2.20
1586	0	-10	15	19.65	3.50	5.24	11.49	0.20	-0.57	1.25	3.63	0.46
1515	0	0	0	19.65	5.43	-0.08	11.49	0.03	6.34	-0.02	1.86	2.29
1531	0	0	5	19.65	8.05	6.69	11.49	-0.73	8.44	6.76	1.64	2.51
1542	0	10	0	19.62	5.63	0.13	11.49	-0.04	4.78	-1.18	1.94	2.15
1546	0	10	5	19.62	7.54	6.74	11.49	-0.87	9.77	6.95	1.73	2.36
1556	0	20	0	19.68	6.38	0.12	11.49	-0.19	2.66	-1.15	2.05	1.85
1560	0	20	5	19.65	7.51	6.93	11.49	-0.97	9.16	5.67	1.75	2.15
1564	0	20	10	19.62	12.42	20.05	11.49	-3.09	15.45	14.23	1.59	2.31
1568	0	20	15	19.53	22.38	39.50	11.49	-6.61	24.04	21.32	1.35	2.55
1377	3	-10	0	19.81	3.63	0.63	11.49	0.39	-3.32	0.79	2.93	2.33
1381	3	-10	5	19.78	4.24	4.52	11.49	0.56	-1.45	-0.17	2.91	2.35
1385	3	-10	10	19.75	7.21	14.01	11.49	-0.14	2.66	-5.04	2.79	2.47
1389	3	-10	15	19.78	3.75	6.88	11.49	3.30	-11.68	-7.80	4.02	1.24
1306	3	0	0	19.72	3.50	0.11	11.49	0.07	-4.54	0.05	2.73	2.59
1312	3	0	5	19.75	4.26	4.93	11.49	0.48	-3.55	-0.73	2.69	2.63
1317	3	0	10	19.32	7.61	15.09	11.49	-0.11	0.79	-3.60	2.46	2.86
1322	3	0	10	19.72	7.76	15.23	11.49	-0.07	1.02	-3.49	2.47	2.85
1321	3	0	15	19.62	18.16	40.15	11.49	-3.41	14.08	-7.43	1.93	3.39

* Indicates model was close to heave stop

TABLE 5.304.2 - STABILITY DATA IN WIND AXES WITHOUT AIR TARES

30 deg Deadrise, L/R = 0.000, Cv = 4

RUN	Trim deg	Roll deg	Yaw deg	Speed fps	X lb	Y lb	Z lb	K lb-ft	M lb-ft	N lb-ft	Heave in	TD in
1327	3	10	0	19.72	3.64	-0.36	11.49	-0.28	-3.36	-0.66	2.72	2.54
1331	3	10	5	19.72	3.98	4.21	11.49	0.27	-5.13	-2.20	2.80	2.46
1335	3	10	10	19.68	6.40	12.31	11.49	0.35	-3.89	-4.88	2.65	2.61
1339	3	10	15	19.65	15.12	32.44	11.49	-2.14	7.26	-4.06	2.07	3.19
1340	3	10	15	19.68	15.12	32.38	11.49	-2.12	7.36	-3.93	2.07	3.19
1345	3	20	0	19.75	3.47	-0.16	11.49	-0.47	-1.92	-1.05	2.79	2.28
1362	3	20	5	19.78	3.48	2.70	11.49	-0.08	-4.36	-2.58	3.15	1.92
1366	3	20	10	19.75	4.89	7.65	11.49	0.31	-6.18	-6.57	3.20	1.87
1372	3	20	15	19.78	8.35	16.04	11.49	0.17	-6.79	-13.18	3.17	1.90
1497	6	-10	0	19.72	2.43	0.72	11.49	0.39	-12.61	-0.72	4.40	2.02
1501	6	-10	5	19.68	2.94	3.72	11.49	1.16	-11.55	-4.48	4.33	2.09
1505	6	-10	10	19.65	4.07	7.40	11.49	1.63	-11.16	-8.98	4.33	2.09
1509	6	-10	15	19.65	7.90	15.96	11.49	1.22	-9.69	-19.69	4.07	2.35
1408	6	0	0	19.75	2.30	-0.23	11.49	0.22	-13.38	0.12	4.49	1.99
1412	6	0	5	19.78	2.87	3.39	11.49	1.01	-13.28	-4.66	4.48	2.00
1439	6	0	5	19.81	2.80	3.27	11.49	1.07	-13.62	-4.73	4.55	1.93
1443	6	0	10	19.68	4.01	7.57	11.49	1.66	-13.00	-9.92	4.52	1.96
1458	6	0	15	19.68	6.78	13.64	11.49	1.83	-12.38	-16.80	4.22	2.26
1463	6	10	0	19.68	2.40	-1.03	11.49	-0.00	-12.98	0.60	4.43	1.99
1467	6	10	5	19.65	2.62	2.48	11.49	0.76	-13.50	-3.69	4.45	1.97
1471	6	10	10	19.65	3.68	6.17	11.49	1.52	-13.81	-8.99	4.45	1.97
1475	6	10	15	19.65	5.83	11.35	11.49	1.88	-13.92	-15.87	4.43	1.99
1480	6	20	0	19.72	2.41	-0.78	11.49	-0.26	-11.81	0.70	4.46	1.77
1484	6	20	5	19.68	2.19	1.39	11.49	0.64	-13.16	-2.36	4.65	1.58
1488	6	20	10	19.68	2.77	3.55	11.49	1.53	-13.93	-5.95	4.69	1.54
1492	6	20	15	19.68	3.95	6.22	11.49	2.24	-14.17	-10.27	4.69	1.54

* Indicates model was close to heave stop

TABLE 5.310.1 - STABILITY DATA IN WIND AXES WITHOUT AIR TARES

30 deg Deadrise, L/R = 0.117, Cv = 0

RUN	Trim deg	Roll deg	Yaw deg	Speed fps	X lb	Y lb	Z lb	K lb-ft	M lb-ft	N lb-ft	Heave in	TD in
563	0	-10	-15	0.00	0.02	0.07	11.49	-0.54	-3.09	0.00	1.82	2.27
560	0	-10	-10	0.00	0.04	0.09	11.49	-0.26	-3.09	0.01	1.82	2.27
555	0	-10	-5	0.00	0.05	0.08	11.49	0.01	-3.11	0.00	1.81	2.28
527	0	-10	0	0.00	0.03	0.12	11.49	0.27	-3.07	0.03	1.89	2.20
548	0	-10	0	0.00	0.01	0.01	11.49	0.31	-3.09	0.03	1.87	2.22
531	0	-10	5	0.00	0.01	0.11	11.49	0.54	-3.04	0.04	1.88	2.21
535	0	-10	10	0.00	0.03	0.16	11.49	0.79	-2.95	0.06	1.89	2.20
551	0	-10	15	0.00	0.04	0.12	11.49	1.06	-2.91	0.04	1.83	2.26
463	0	0	-15	0.00	0.04	0.08	11.49	-0.72	-2.84	0.02	1.83	2.32
460	0	0	-10	0.00	0.06	0.08	11.49	-0.47	-2.88	0.01	1.84	2.31
456	0	0	-5	0.00	0.05	0.07	11.49	-0.21	-2.94	0.00	1.81	2.34
77	0	0	0	0.00	0.04	0.09	11.49	0.04	-2.73	0.01	1.97	2.18
441	0	0	0	0.00	0.10	0.00	11.49	0.05	-2.89	0.02	1.84	2.31
476	0	0	0	0.00	0.06	0.49	11.49	0.05	-2.90	-0.77	1.85	2.30
446	0	0	5	0.00	0.04	0.12	11.49	0.30	-2.81	0.04	1.86	2.29
451	0	0	10	0.00	0.03	0.14	11.49	0.54	-2.76	0.04	1.87	2.28
454	0	0	15	0.00	0.04	0.11	11.49	0.80	-2.85	0.03	1.81	2.34
495	0	10	-15	0.00	0.02	0.09	11.49	-0.97	-2.93	0.01	1.91	2.18
491	0	10	-10	0.00	0.04	0.08	11.49	-0.72	-3.00	0.01	1.88	2.21
487	0	10	-5	0.00	0.06	0.08	11.49	-0.46	-3.00	0.00	1.87	2.22
466	0	10	0	0.00	0.04	0.10	11.49	-0.20	-3.10	0.02	1.91	2.18
478	0	10	5	0.00	0.05	0.12	11.49	0.09	-3.05	0.03	1.90	2.19
482	0	10	10	0.00	0.05	0.14	11.49	0.35	-3.01	0.06	1.91	2.18
485	0	10	15	0.00	0.06	0.10	11.49	0.60	-3.03	0.05	1.88	2.21
522	0	20	-15	0.00	-0.00	0.08	11.49	-1.19	-3.12	0.00	1.96	1.94
518	0	20	-10	0.00	0.04	0.10	11.49	-0.91	-3.18	0.01	1.96	1.94
514	0	20	-5	0.00	0.08	0.10	11.49	-0.59	-3.01	-0.07	1.95	1.95
500	0	20	0	0.00	0.03	0.04	11.49	-0.31	-3.16	0.01	2.01	1.89
504	0	20	5	0.00	0.05	0.14	11.49	-0.04	-3.26	0.03	1.96	1.94
508	0	20	10	0.00	0.05	0.11	11.49	0.24	-3.20	0.03	1.97	1.93
512	0	20	15	0.00	0.06	0.12	11.49	0.52	-3.27	0.03	1.95	1.95
275	3	-10	-15	0.00	0.07	0.28	11.49	-1.72	-7.56	0.03	2.17	3.09
271	3	-10	-10	0.00	0.05	0.19	11.49	-1.07	-7.88	0.01	2.12	3.14
266	3	-10	-5	0.00	0.03	0.13	11.49	-0.39	-8.08	0.01	2.10	3.16
245	3	-10	0	0.00	0.03	0.11	11.49	0.31	-7.98	0.00	2.14	3.12
250	3	-10	5	0.00	0.03	0.13	11.49	1.03	-8.05	0.00	2.09	3.17
256	3	-10	10	0.00	0.03	0.13	11.49	1.74	-7.99	0.02	2.09	3.17
260	3	-10	15	0.00	0.03	0.14	11.49	2.43	-7.84	0.00	2.08	3.18
128	3	0	-15	0.00	0.05	0.15	11.49	-2.01	-7.87	0.01	2.21	3.11
123	3	0	-10	0.00	0.05	0.12	11.49	-1.35	-8.18	0.02	2.17	3.15
119	3	0	-5	0.00	0.03	0.12	11.49	-0.63	-8.20	0.00	2.15	3.17
80	3	0	0	0.00	0.06	0.05	11.49	0.08	-8.16	0.02	2.19	3.13
85	3	0	5	0.00	0.05	0.13	11.49	0.81	-8.17	0.02	2.17	3.15
110	3	0	10	0.00	0.05	0.11	11.49	1.54	-8.18	0.03	2.16	3.16
114	3	0	15	0.00	0.07	0.10	11.49	2.22	-7.93	0.03	2.17	3.15

* Indicates model was close to heave stop

TABLE 5.310.2 - STABILITY DATA IN WIND AXES WITHOUT AIR TARES

30 deg Deadrise, L/R = 0.117, Cv = 0

RUN	Trim deg	Roll deg	Yaw deg	Speed fps	X lb	Y lb	Z lb	K lb-ft	M lb-ft	N lb-ft	Heave in	TD in
190	3	10	-15	0.00	0.09	0.36	11.49	-2.12	-7.40	0.08	2.21	3.05
183	3	10	-10	0.00	0.10	0.51	11.49	-1.36	-7.06	0.13	2.32	2.94
179	3	10	-5	0.00	0.12	0.26	11.49	-0.81	-7.78	0.03	2.18	3.08
137	3	10	0	0.00	0.10	0.24	11.49	-0.14	-7.78	0.04	2.25	3.01
169	3	10	0	0.00	0.03	0.10	11.49	-0.13	-8.12	0.00	2.20	3.06
145	3	10	5	0.00	0.05	0.15	11.49	0.56	-8.06	0.02	2.23	3.03
149	3	10	10	0.00	0.05	0.15	11.49	1.28	-8.04	0.03	2.23	3.03
239	3	20	-15	0.00	0.11	0.38	11.49	-2.21	-7.30	0.06	2.24	2.83
234	3	20	-10	0.00	0.08	0.24	11.49	-1.64	-7.80	0.03	2.19	2.88
230	3	20	-5	0.00	0.05	0.18	11.49	-0.98	-8.08	0.01	2.15	2.92
196	3	20	0	0.00	0.04	0.14	11.49	-0.27	-8.20	0.00	2.23	2.84
203	3	20	5	0.00	0.03	0.15	11.49	0.45	-8.24	0.03	2.22	2.85
208	3	20	10	0.00	0.03	0.14	11.49	1.17	-8.19	0.01	2.22	2.85
209	3	20	10	0.00	0.03	0.12	11.49	1.17	-8.21	0.02	2.22	2.85
213	3	20	15	0.00	0.02	0.14	11.49	1.90	-8.12	0.01	2.21	2.86
227	3	20	15	0.00	0.04	0.14	11.49	1.87	-8.06	0.01	2.18	2.89
436	6	-10	-15	0.00	0.10	0.49	11.49	-2.35	-10.00	0.11	2.57	3.85
432	6	-10	-10	0.00	0.08	0.30	11.49	-1.56	-10.77	0.05	2.49	3.93
428	6	-10	-5	0.00	0.06	0.27	11.49	-0.63	-11.08	0.04	2.44	3.98
403	6	-10	0	0.00	0.12	0.93	11.49	0.29	-9.21	0.33	2.82	3.60
407	6	-10	5	0.00	0.06	0.15	11.49	1.32	-11.21	0.05	2.56	3.86
411	6	-10	10	0.00	0.05	0.16	11.49	2.30	-11.08	0.05	2.56	3.86
424	6	-10	15	0.00	0.05	0.10	11.49	3.25	-10.82	0.03	2.46	3.96
323	6	0	-15	0.00	0.04	0.27	11.49	-2.74	-10.69	0.06	2.51	3.97
317	6	0	-10	0.00	0.05	0.29	11.49	-1.80	-10.89	0.06	2.49	3.99
311	6	0	-5	0.00	0.04	0.19	11.49	-0.85	-11.14	0.04	2.47	4.01
289	6	0	0	0.00	0.07	0.23	11.49	0.13	-10.89	0.06	2.57	3.91
295	6	0	5	0.00	0.04	0.15	11.49	1.12	-11.30	0.04	2.48	4.00
298	6	0	10	0.00	0.06	0.16	11.49	2.11	-11.22	0.06	2.46	4.02
302	6	0	15	0.00	0.05	0.14	11.49	3.08	-11.01	0.04	2.46	4.02
308	6	0	15	0.00	0.04	0.14	11.49	3.08	-11.02	0.03	2.43	4.05
364	6	10	-15	0.00	0.07	0.25	11.49	-2.93	-10.64	0.05	2.58	3.84
359	6	10	-10	0.00	0.06	0.18	11.49	-2.03	-11.05	0.01	2.54	3.88
346	6	10	-5	0.00	0.05	0.14	11.49	-1.09	-11.38	0.02	2.45	3.97
355	6	10	-5	0.00	0.07	0.17	11.49	-1.07	-11.20	0.01	2.53	3.89
329	6	10	0	0.00	0.05	0.10	11.49	-0.09	-11.37	0.02	2.49	3.93
334	6	10	5	0.00	0.05	0.14	11.49	0.91	-11.38	0.06	2.45	3.97
338	6	10	10	0.00	0.06	0.14	11.49	1.90	-11.29	0.06	2.44	3.98
342	6	10	15	0.00	0.05	0.15	11.49	2.89	-11.12	0.06	2.44	3.98
369	6	10	15	0.00	0.07	0.15	11.49	2.87	-11.04	0.04	2.52	3.90
397	6	20	-15	0.00	0.04	0.16	11.49	-3.19	-10.93	0.00	2.62	3.61
393	6	20	-10	0.00	0.05	0.13	11.49	-2.21	-11.11	0.00	2.63	3.60
389	6	20	-5	0.00	0.03	0.14	11.49	-1.24	-11.30	0.01	2.60	3.63
372	6	20	0	0.00	0.06	0.15	11.49	-0.26	-11.34	0.02	2.59	3.64
376	6	20	5	0.00	0.00	0.13	11.49	0.75	-11.42	0.02	2.57	3.66
381	6	20	10	0.00	0.05	0.14	11.49	1.73	-11.25	0.04	2.58	3.65
385	6	20	15	0.00	0.05	0.14	11.49	2.71	-11.09	0.04	2.58	3.65

* Indicates model was close to heave stop

TABLE 5.311.1 - STABILITY DATA IN WIND AXES WITHOUT AIR TARES

30 deg Deadrise, L/R = 0.117, Cv = 1.5

RUN	Trim deg	Roll deg	Yaw deg	Speed fps	X lb	Y lb	Z lb	K lb-ft	M lb-ft	N lb-ft	Heave in	TD in	
564	*	0	-10	-15	7.35	4.17	-7.40	11.49	1.18	2.52	-7.74	0.68	3.41
561		0	-10	-10	7.36	2.14	-2.86	11.49	0.68	1.15	-3.96	1.24	2.85
556		0	-10	-5	7.37	1.40	-0.87	11.49	0.42	0.58	-2.02	1.46	2.63
528		0	-10	0	7.37	1.16	0.13	11.49	0.25	0.61	-0.55	1.58	2.51
532		0	-10	5	7.37	1.35	0.91	11.49	0.11	1.04	0.37	1.53	2.56
536		0	-10	10	7.37	1.96	2.56	11.49	-0.16	1.68	1.45	1.36	2.73
550		0	-10	15	7.38	3.35	5.40	11.49	-0.82	2.93	3.51	1.01	3.08
464	*	0	0	-15	7.35	4.19	-7.86	11.49	0.55	1.64	-7.80	0.85	3.30
461		0	0	-10	7.36	2.24	-3.22	11.49	0.41	1.35	-4.11	1.23	2.92
457		0	0	-5	7.36	1.52	-1.02	11.49	0.15	0.90	-2.21	1.43	2.72
78		0	0	0	7.38	1.19	0.05	11.49	0.01	0.70	-0.78	1.64	2.51
443		0	0	0	7.38	1.29	-0.01	11.49	0.03	0.77	-0.80	1.54	2.61
448		0	0	5	7.38	1.38	0.93	11.49	-0.09	1.23	0.23	1.51	2.64
452		0	0	10	7.37	2.02	2.65	11.49	-0.43	2.19	1.12	1.31	2.84
455	*	0	0	15	7.37	4.12	6.84	11.49	-1.18	4.14	2.99	0.77	3.38
496		0	10	-15	7.36	3.63	-6.49	11.49	0.68	1.95	-7.58	1.05	3.04
492		0	10	-10	7.37	2.16	-3.17	11.49	0.26	1.27	-4.26	1.30	2.79
488		0	10	-5	7.38	1.50	-1.08	11.49	-0.01	0.80	-2.26	1.48	2.61
467		0	10	0	7.36	1.23	0.06	11.49	-0.16	0.68	-0.93	1.58	2.51
479		0	10	5	7.38	1.30	0.79	11.49	-0.34	1.08	0.13	1.53	2.56
483		0	10	10	7.36	1.94	2.40	11.49	-0.77	2.11	1.23	1.34	2.75
486	*	0	10	15	7.37	3.70	5.91	11.49	-1.68	4.44	2.64	0.82	3.27
523		0	20	-15	7.38	3.88	-6.29	11.49	1.04	3.18	-7.77	0.99	2.91
519		0	20	-10	7.37	2.11	-2.67	11.49	0.16	1.41	-4.13	1.42	2.48
515		0	20	-5	7.37	1.53	-0.91	11.49	-0.14	0.88	-2.33	1.56	2.34
501		0	20	0	7.39	1.24	-0.10	11.49	-0.33	0.43	-1.01	1.65	2.25
505		0	20	5	7.38	1.29	0.73	11.49	-0.49	0.81	-0.11	1.61	2.29
509		0	20	10	7.37	1.83	2.11	11.49	-0.96	1.88	1.01	1.40	2.50
513		0	20	15	7.37	3.49	5.32	11.49	-1.96	4.36	2.93	0.95	2.95
276	3	-10	-15	-15	7.36	2.67	-3.93	11.49	-0.35	-2.84	-0.54	1.76	3.50
272	3	-10	-10	-10	7.36	1.70	-1.79	11.49	-0.38	-4.48	-0.66	1.86	3.40
267	3	-10	-5	-5	7.35	1.30	-0.35	11.49	-0.09	-5.04	-0.47	1.94	3.32
246	3	-10	0	0	7.38	1.17	0.49	11.49	0.33	-4.99	-0.32	1.96	3.30
249	3	-10	5	5	7.37	1.38	1.42	11.49	0.70	-4.44	-0.42	1.91	3.35
251	3	-10	5	5	7.37	1.37	1.41	11.49	0.70	-4.44	-0.43	1.92	3.34
253	3	-10	5	5	7.37	1.36	1.43	11.49	0.69	-4.41	-0.43	1.92	3.34
257	3	-10	10	10	7.37	2.07	3.42	11.49	0.81	-3.33	-0.99	1.75	3.51
261	3	-10	15	15	7.37	3.34	6.23	11.49	0.83	-2.51	-1.31	1.58	3.68
129	3	0	-15	-15	7.36	3.20	-5.79	11.49	-0.88	-3.13	-1.30	1.66	3.66
124	3	0	-10	-10	7.37	1.81	-2.30	11.49	-0.74	-4.52	-1.01	1.92	3.40
120	3	0	-5	-5	7.38	1.32	-0.57	11.49	-0.39	-5.12	-0.82	2.01	3.31
81	3	0	0	0	7.36	1.23	0.32	11.49	0.08	-5.24	-0.54	2.02	3.30
87	3	0	5	5	7.36	1.07	0.28	11.49	0.54	-5.20	-0.55	2.03	3.29
107	3	0	5	5	7.36	1.38	1.33	11.49	0.55	-4.81	-0.44	1.97	3.35
111	3	0	10	10	7.35	1.99	3.15	11.49	0.73	-3.84	-0.82	1.85	3.47
115	3	0	15	15	7.36	3.49	6.56	11.49	0.55	-2.07	-1.67	1.59	3.73
135	3	0	15	15	7.36	3.61	6.76	11.49	0.54	-1.99	-1.60	1.53	3.79

* Indicates model was close to heave stop

TABLE 5.311.2 - STABILITY DATA IN WIND AXES WITHOUT AIR TARES

30 deg Deadrise, L/R = 0.117, Cv = 1.5

RUN	Trim deg	Roll deg	Yaw deg	Speed fps	X lb	Y lb	Z lb	K lb-ft	M lb-ft	N lb-ft	Heave in	TD in
188	3	10	-15	7.37	2.49	-3.29	11.49	-0.54	-1.66	-0.01	2.02	3.24
184	3	10	-10	7.37	1.97	-2.34	11.49	-0.79	-3.56	-0.72	1.93	3.33
180	3	10	-5	7.37	1.48	-0.51	11.49	-0.57	-4.34	-0.72	2.06	3.20
138	3	10	0	7.37	1.26	0.38	11.49	-0.19	-4.74	-0.63	2.11	3.15
144	3	10	5	7.37	1.32	1.13	11.49	0.20	-4.73	-0.70	2.05	3.21
146	3	10	5	7.37	1.33	1.18	11.49	0.21	-4.73	-0.70	2.06	3.20
150	3	10	10	7.37	1.81	2.72	11.49	0.43	-4.00	-0.93	1.92	3.34
170	3	10	15	7.37	3.20	5.78	11.49	0.30	-2.41	-1.54	1.58	3.68
173	3	10	15	7.37	3.21	5.81	11.49	0.31	-2.42	-1.51	1.59	3.67
174	3	10	15	7.36	3.23	5.85	11.49	0.31	-2.41	-1.50	1.59	3.67
240	3	20	-15	7.35	2.41	-2.59	11.49	-0.39	-1.08	0.32	1.92	3.15
235	3	20	-10	7.34	1.72	-1.73	11.49	-0.87	-3.54	-0.37	1.98	3.09
231	3	20	-5	7.36	1.41	-0.56	11.49	-0.70	-4.42	-0.60	2.02	3.05
197	3	20	0	7.38	1.21	0.34	11.49	-0.34	-4.86	-0.67	2.09	2.98
204	3	20	5	7.29	1.28	1.15	11.49	0.01	-4.71	-0.81	2.03	3.04
210	3	20	10	7.32	1.77	2.55	11.49	0.18	-4.06	-1.22	1.90	3.17
214	3	20	15	7.35	2.99	5.23	11.49	-0.15	-2.11	-1.79	1.58	3.49
437	6	-10	-15	7.36	2.62	-3.05	11.49	-1.30	-7.11	2.77	2.40	4.02
433	6	-10	-10	7.37	1.99	-1.68	11.49	-1.05	-8.36	1.42	2.43	3.99
429	6	-10	-5	7.37	1.66	-0.49	11.49	-0.38	-8.72	0.46	2.47	3.95
404	6	-10	0	7.36	1.59	0.66	11.49	0.34	-8.45	-0.38	2.62	3.80
408	6	-10	5	7.38	1.84	1.82	11.49	0.98	-8.16	-1.34	2.53	3.89
412	6	-10	10	7.37	2.50	3.87	11.49	1.35	-7.35	-2.95	2.40	4.02
425	6	-10	15	7.38	3.88	7.12	11.49	1.45	-6.20	-5.57	2.03	4.39
325	6	0	-15	7.37	2.95	-4.18	11.49	-1.54	-7.24	2.76	2.30	4.18
318	6	0	-10	7.37	2.02	-1.89	11.49	-1.25	-8.20	1.19	2.45	4.03
312	6	0	-5	7.38	1.66	-0.52	11.49	-0.68	-8.88	0.27	2.49	3.99
290	6	0	0	7.39	1.42	0.60	11.49	0.10	-8.85	-0.44	2.59	3.89
294	6	0	5	7.37	1.74	1.74	11.49	0.81	-8.63	-1.33	2.50	3.98
299	6	0	10	7.37	2.39	3.53	11.49	1.30	-7.90	-2.68	2.35	4.13
303	6	0	15	7.37	3.58	6.39	11.49	1.41	-6.65	-4.78	2.14	4.34
309	6	0	15	7.38	3.63	6.50	11.49	1.40	-6.69	-4.84	2.05	4.43
365	6	10	-15	7.36	3.06	-4.54	11.49	-1.64	-6.72	3.07	2.36	4.06
360	6	10	-10	7.37	2.06	-2.09	11.49	-1.41	-7.97	1.20	2.46	3.96
347	6	10	-5	7.37	1.71	-0.57	11.49	-0.90	-8.67	0.13	2.47	3.95
330	6	10	0	7.37	1.57	0.48	11.49	-0.17	-8.96	-0.66	2.52	3.90
335	6	10	5	7.38	1.72	1.70	11.49	0.56	-8.78	-1.51	2.47	3.95
339	6	10	10	7.38	2.28	3.28	11.49	1.14	-8.20	-2.71	2.36	4.06
343	6	10	15	7.38	3.44	5.84	11.49	1.31	-7.04	-4.56	2.12	4.30
398	6	20	-15	7.36	2.88	-3.99	11.49	-1.61	-6.24	3.19	2.44	3.79
394	6	20	-10	7.36	2.14	-2.32	11.49	-1.50	-7.79	1.60	2.55	3.68
390	6	20	-5	7.36	1.69	-0.62	11.49	-1.01	-8.35	0.30	2.62	3.61
373	6	20	0	7.36	1.59	0.61	11.49	-0.38	-8.60	-0.64	2.60	3.63
377	6	20	5	7.36	1.74	1.85	11.49	0.25	-8.39	-1.76	2.58	3.65
382	6	20	10	7.38	2.29	3.52	11.49	0.75	-7.58	-3.26	2.47	3.76
386	6	20	15	7.36	3.15	5.16	11.49	1.09	-6.82	-4.58	2.36	3.87

* Indicates model was close to heave stop

TABLE 5.313.1 - STABILITY DATA IN WIND AXES WITHOUT AIR TARES

30 deg Deadrise, L/R = 0.117, Cv = 3

RUN	Trim deg	Roll deg	Yaw deg	Speed fps	X lb	Y lb	Z lb	K lb-ft	M lb-ft	N lb-ft	Heave in	TD in	
562	*	0	-10	-10	14.75	9.72	-18.01	11.49	0.71	-0.46	-18.38	0.63	3.46
558		0	-10	-5	14.75	4.44	-4.72	11.49	0.70	3.45	-7.12	1.51	2.58
529		0	-10	0	14.74	3.13	-0.24	11.49	0.26	1.73	-1.59	1.78	2.31
533		0	-10	5	14.75	4.29	3.84	11.49	-0.14	3.08	0.54	1.59	2.50
537		0	-10	10	14.74	7.97	13.87	11.49	-0.81	4.00	2.73	1.12	2.97
552		0	-10	15	14.74	6.47	11.78	11.49	-0.23	2.06	3.20	2.21	1.88
462	*	0	0	-10	14.72	9.38	-18.18	11.49	0.61	1.83	-17.93	0.87	3.28
458		0	0	-5	14.73	4.55	-4.50	11.49	0.34	2.11	-6.88	1.60	2.55
444		0	0	0	14.74	3.31	-0.19	11.49	0.07	2.65	-2.64	1.74	2.41
449		0	0	5	14.76	4.17	3.78	11.49	-0.30	4.57	0.40	1.58	2.57
453	*	0	0	10	14.76	10.33	17.59	11.49	-1.21	5.51	2.95	0.55	3.60
497		0	10	-15	14.73	3.79	-5.21	11.49	1.53	8.30	-4.22	2.86	1.23
493		0	10	-10	14.75	7.37	-14.24	11.49	0.95	3.24	-14.56	1.40	2.69
489		0	10	-5	14.75	4.48	-4.70	11.49	0.28	2.08	-6.34	1.67	2.42
468		0	10	0	14.73	3.65	-0.06	11.49	-0.12	1.51	-2.37	1.76	2.33
480		0	10	5	14.75	4.16	3.99	11.49	-0.48	4.47	0.56	1.55	2.54
484		0	10	10	14.74	8.06	14.00	11.49	-1.36	6.33	2.58	1.02	3.07
524		0	20	-15	14.75	6.77	-9.58	11.49	3.75	13.63	-5.96	2.24	1.66
520		0	20	-10	14.74	6.87	-9.05	11.49	2.20	12.76	-9.59	1.58	2.32
516		0	20	-5	14.74	4.42	-4.78	11.49	0.22	2.52	-6.26	1.77	2.13
502		0	20	0	14.77	3.51	-0.52	11.49	-0.28	1.50	-2.56	1.83	2.07
506		0	20	5	14.76	3.99	3.37	11.49	-0.65	2.67	-0.01	1.70	2.20
510		0	20	10	14.75	7.19	12.07	11.49	-1.49	5.78	4.48	1.28	2.62
277		3	-10	-15	14.73	7.98	-17.48	11.49	0.63	1.27	-2.16	2.00	3.26
273		3	-10	-10	14.74	3.97	-7.24	11.49	-0.16	-3.31	-0.87	2.30	2.96
269		3	-10	-5	14.75	2.66	-1.88	11.49	-0.00	-4.18	-0.69	2.37	2.89
247		3	-10	0	14.74	2.32	1.30	11.49	0.40	-4.00	-0.77	2.38	2.88
254		3	-10	5	14.74	3.13	4.60	11.49	0.60	-2.81	-1.81	2.36	2.90
258		3	-10	10	14.73	5.42	12.09	11.49	0.04	0.49	-5.94	2.15	3.11
262		3	-10	15	14.77	3.66	7.11	11.49	2.85	-9.23	-5.70	3.34	1.92
130		3	0	-15	14.68	9.66	-22.23	11.49	0.77	4.53	-2.18	1.95	3.37
125		3	0	-10	14.71	4.42	-8.46	11.49	-0.28	-1.48	-1.84	2.32	3.00
121		3	0	-5	14.72	2.90	-2.42	11.49	-0.38	-4.16	-1.83	2.43	2.89
82		3	0	0	14.67	2.40	0.91	11.49	0.10	-4.73	-1.38	2.47	2.85
88		3	0	5	14.71	1.73	0.73	11.49	0.52	-4.94	-1.40	2.48	2.84
101		3	0	5	14.71	3.09	5.07	11.49	0.49	-4.08	-3.12	2.42	2.90
105		3	0	5	14.67	3.02	4.47	11.49	0.50	-3.65	-1.92	2.41	2.91
112		3	0	10	14.68	5.55	11.89	11.49	0.09	-0.26	-4.54	2.15	3.17
116		3	0	15	14.68	12.03	27.61	11.49	-2.04	7.72	-8.24	1.57	3.75
132		3	0	15	14.67	12.89	29.28	11.49	-2.24	8.68	-7.56	1.41	3.91

* Indicates model was close to heave stop

TABLE 5.313.2 - STABILITY DATA IN WIND AXES WITHOUT AIR TARES

30 deg Deadrise, L/R = 0.117, Cv = 3

RUN	Trim deg	Roll deg	Yaw deg	Speed fps	X lb	Y lb	Z lb	K lb-ft	M lb-ft	N lb-ft	Heave in	TD in
191	3	10	-15	14.73	3.07	-5.07	11.49	-1.63	-5.04	2.53	3.25	2.01
185	3	10	-10	14.73	4.40	-8.34	11.49	-0.20	0.31	-0.18	2.37	2.89
181	3	10	-5	14.72	2.85	-2.54	11.49	-0.51	-2.60	-1.57	2.46	2.80
141	3	10	0	14.68	2.44	0.69	11.49	-0.25	-4.18	-2.05	2.55	2.71
147	3	10	5	14.71	2.65	3.89	11.49	0.23	-4.20	-2.73	2.53	2.73
151	3	10	10	14.70	4.45	9.36	11.49	0.22	-2.33	-4.15	2.37	2.89
175	3	10	15	14.69	10.06	22.31	11.49	-1.58	4.80	-7.23	1.79	3.47
241	3	20	-15	14.72	2.99	-4.37	11.49	-1.21	-3.18	3.56	3.11	1.96
236	3	20	-10	14.77	3.19	-4.29	11.49	-0.48	-0.64	1.15	2.64	2.43
232	3	20	-5	14.74	2.84	-2.27	11.49	-0.59	-2.42	-0.57	2.44	2.63
200	3	20	0	14.72	2.41	1.03	11.49	-0.49	-3.14	-2.16	2.50	2.57
206	3	20	5	14.66	2.51	3.64	11.49	-0.12	-3.76	-3.45	2.60	2.47
211	3	20	10	14.74	3.66	7.39	11.49	0.06	-4.01	-5.87	2.63	2.44
215	3	20	15	14.98	6.28	13.81	11.49	-0.15	-3.66	-9.91	2.57	2.50
216	3	20	15	14.75	6.25	13.64	11.49	-0.18	-3.41	-9.55	2.55	2.52
438	6	-10	-15	14.75	4.14	-7.71	11.49	-1.61	-10.17	8.06	3.55	2.87
434	6	-10	-10	14.73	2.73	-3.90	11.49	-1.16	-10.41	4.21	3.58	2.84
430	6	-10	-5	14.73	2.06	-1.13	11.49	-0.40	-9.93	1.37	3.48	2.94
405	6	-10	0	14.71	2.08	1.50	11.49	0.37	-8.74	-0.90	3.46	2.96
409	6	-10	5	14.75	3.01	5.14	11.49	0.80	-7.86	-4.53	3.34	3.08
413	6	-10	10	14.75	4.50	10.12	11.49	0.70	-6.81	-9.73	3.28	3.14
426	6	-10	15	14.74	7.98	18.69	11.49	-0.28	-4.09	-18.01	2.92	3.50
326	6	0	-15	14.75	5.30	-10.44	11.49	-1.04	-7.04	7.75	3.16	3.32
319	6	0	-10	14.77	3.11	-4.73	11.49	-1.25	-9.01	3.60	3.38	3.10
315	6	0	-5	14.76	2.34	-1.40	11.49	-0.70	-10.04	0.96	3.46	3.02
292	6	0	0	14.78	2.09	1.47	11.49	0.10	-10.05	-1.42	3.55	2.93
296	6	0	5	14.76	2.65	4.41	11.49	0.81	-9.39	-3.89	3.44	3.04
300	6	0	10	14.76	4.20	8.92	11.49	1.08	-8.21	-8.13	3.29	3.19
304	6	0	15	14.72	7.46	16.85	11.49	0.26	-5.51	-15.36	2.99	3.49
366	6	10	-15	14.74	6.05	-12.30	11.49	-0.68	-5.39	10.00	3.13	3.29
361	6	10	-10	14.86	3.37	-4.88	11.49	-1.14	-7.36	3.72	3.32	3.10
363	6	10	-10	14.72	3.35	-4.99	11.49	-1.15	-7.34	3.72	3.34	3.08
357	6	10	-5	14.78	2.39	-1.29	11.49	-0.94	-8.77	0.29	3.42	3.00
331	6	10	0	14.75	2.04	1.21	11.49	-0.20	-10.04	-1.72	3.56	2.86
336	6	10	5	14.77	2.42	4.06	11.49	0.59	-10.76	-4.47	3.59	2.83
340	6	10	10	14.76	3.62	7.50	11.49	1.26	-10.90	-8.17	3.57	2.85
344	6	10	15	14.76	5.83	12.50	11.49	1.44	-10.00	-12.91	3.41	3.01
400	6	20	-15	14.73	4.79	-9.05	11.49	-1.45	-7.81	9.76	3.58	2.65
395	6	20	-10	14.69	3.27	-5.24	11.49	-1.13	-7.22	5.06	3.47	2.76
391	6	20	-5	14.72	2.45	-1.02	11.49	-1.04	-7.81	0.54	3.43	2.80
374	6	20	0	14.77	2.13	1.40	11.49	-0.47	-8.95	-1.87	3.60	2.63
378	6	20	5	14.74	2.22	3.49	11.49	0.27	-10.41	-4.29	3.79	2.44
383	6	20	10	14.77	2.98	5.85	11.49	1.06	-11.37	-7.36	3.92	2.31
387	6	20	15	14.72	4.39	8.60	11.49	1.72	-11.90	-11.15	3.96	2.27

* Indicates model was close to heave stop

TABLE 5.314.1 - STABILITY DATA IN WIND AXES WITHOUT AIR TARES

30 deg Deadrise, L/R = 0.117, Cv = 4

RUN	Trim deg	Roll deg	Yaw deg	Speed fps	X lb	Y lb	Z lb	K lb-ft	M lb-ft	N lb-ft	Heave in	TD in
559	0	-10	-5	19.58	7.49	-8.05	11.49	1.13	8.65	-13.34	1.50	2.59
530	0	-10	0	19.66	5.40	-0.55	11.49	0.16	5.42	-3.16	1.72	2.37
534	0	-10	5	19.64	8.79	8.06	11.49	-0.63	7.32	-0.93	1.24	2.85
554 *	0	-10	10	19.61	15.20	27.01	11.49	-0.89	4.19	10.79	0.67	3.42
553	0	-10	15	19.61	3.53	6.18	11.49	0.85	-2.09	1.09	3.22	0.87
459	0	0	-5	19.61	8.20	-7.07	11.49	0.92	6.06	-13.25	1.50	2.65
445	0	0	0	19.65	5.35	-0.47	11.49	0.09	5.93	-4.75	1.77	2.38
450	0	0	5	19.66	7.52	6.99	11.49	-0.68	9.27	0.14	1.45	2.70
498	0	10	-15	19.69	3.52	-5.54	11.49	0.39	1.87	-2.16	3.32	0.77
494	0	10	-10	19.64	12.20	-23.70	11.49	1.44	4.22	-26.83	1.44	2.65
490	0	10	-5	19.65	8.00	-7.69	11.49	0.87	5.33	-13.58	1.60	2.49
469	0	10	0	19.63	6.39	0.15	11.49	-0.03	3.46	-4.23	1.74	2.35
481	0	10	5	19.62	7.51	7.52	11.49	-0.67	9.74	1.37	1.43	2.66
525	0	20	-15	19.62	5.97	-7.59	11.49	2.53	9.69	-1.67	2.98	0.92
521	0	20	-10	19.66	10.25	-13.28	11.49	3.86	22.81	-13.99	1.80	2.10
517	0	20	-5	19.61	7.65	-8.12	11.49	0.81	6.12	-12.68	1.75	2.15
503	0	20	0	19.67	6.32	-0.44	11.49	-0.15	3.25	-5.09	1.80	2.10
507	0	20	5	19.67	7.31	7.02	11.49	-0.68	5.57	0.89	1.58	2.32
278	3	-10	-15	19.60	13.00	-30.11	11.49	1.56	5.21	-4.09	2.09	3.17
274	3	-10	-10	19.60	5.77	-11.29	11.49	-0.07	-3.82	0.29	2.51	2.75
270	3	-10	-5	19.63	3.66	-2.43	11.49	-0.02	-4.60	-0.48	2.67	2.59
248	3	-10	0	19.63	3.46	2.25	11.49	0.42	-2.60	-1.40	2.58	2.68
255	3	-10	5	19.61	4.56	7.16	11.49	0.48	-1.82	-3.56	2.62	2.64
259	3	-10	10	19.66	7.40	16.86	11.49	-0.31	2.16	-9.74	2.51	2.75
265	3	-10	15	19.64	3.79	7.93	11.49	3.52	-13.04	-8.53	3.81	1.45
131	3	0	-15	19.58	16.16	-38.77	11.49	2.29	12.16	-3.36	1.99	3.33
126	3	0	-10	19.62	6.73	-13.54	11.49	0.04	0.73	-2.66	2.46	2.86
122	3	0	-5	19.63	3.88	-3.56	11.49	-0.34	-3.96	-1.72	2.69	2.63
83	3	0	0	19.61	3.48	1.60	11.49	0.14	-4.69	-2.13	2.74	2.58
106	3	0	5	19.60	4.37	7.20	11.49	0.52	-3.37	-3.76	2.66	2.66
113	3	0	10	19.59	7.79	17.73	11.49	-0.15	0.75	-8.83	2.46	2.86
117	3	0	15	19.59	20.40	48.84	11.49	-4.64	17.77	-14.85	1.57	3.75
133	3	0	15	19.61	23.90	56.42	11.49	-5.70	22.32	-11.84	1.07	4.25

* Indicates model was close to heave stop

TABLE 5.314.2 - STABILITY DATA IN WIND AXES WITHOUT AIR TARES

30 deg Deadrise, L/R = 0.117, Cv = 4

RUN	Trim deg	Roll deg	Yaw deg	Speed fps	X lb	Y lb	Z lb	K lb-ft	M lb-ft	N lb-ft	Heave in	TD in
192	3	10	-15	19.66	4.04	-7.39	11.49	-2.63	-9.90	5.91	3.56	1.70
193	3	10	-15	19.65	4.07	-7.66	11.49	-2.39	-9.16	6.25	3.56	1.70
186	3	10	-10	19.63	5.19	-9.99	11.49	-0.04	0.63	1.77	2.83	2.43
182	3	10	-5	19.64	3.50	-3.02	11.49	-0.44	-1.97	-1.50	2.81	2.45
143	3	10	0	19.61	3.29	1.10	11.49	-0.20	-4.45	-2.73	2.82	2.44
148	3	10	5	19.61	3.90	6.17	11.49	0.38	-5.72	-5.03	2.85	2.41
153	3	10	10	19.62	6.35	14.61	11.49	0.36	-4.14	-8.97	2.70	2.56
178	3	10	15	19.63	15.55	35.82	11.49	-2.55	8.32	-12.79	1.97	3.29
243	3	20	-15	19.62	2.71	-3.24	11.49	-2.93	-9.54	3.99	3.65	1.42
238	3	20	-10	19.63	3.18	-3.56	11.49	-1.13	-3.77	2.46	3.16	1.91
233	3	20	-5	19.55	3.74	-2.51	11.49	-0.56	-0.86	-0.75	2.71	2.36
201	3	20	0	19.75	3.01	1.14	11.49	-0.56	-3.00	-2.39	2.85	2.22
202	3	20	0	19.72	2.99	1.18	11.49	-0.54	-3.05	-2.33	2.86	2.21
207	3	20	5	19.68	3.31	4.91	11.49	-0.08	-5.49	-4.85	2.99	2.08
212	3	20	10	19.62	4.93	10.06	11.49	0.20	-6.71	-9.34	2.99	2.08
229	3	20	15	19.59	8.48	18.69	11.49	-0.01	-7.07	-16.57	2.87	2.20
439	6	-10	-15	19.67	4.55	-8.51	11.49	-1.88	-13.61	11.57	4.19	2.23
435	6	-10	-10	19.66	2.93	-4.17	11.49	-1.36	-13.50	5.81	4.22	2.20
431	6	-10	-5	19.65	1.91	-0.52	11.49	-0.59	-13.20	1.27	4.21	2.21
406	6	-10	0	19.64	2.37	2.85	11.49	0.26	-12.37	-2.64	4.20	2.22
410	6	-10	5	19.70	3.13	6.22	11.49	0.95	-11.07	-6.42	4.15	2.27
414	6	-10	10	19.65	4.45	10.14	11.49	1.45	-11.99	-12.24	4.27	2.15
427	6	-10	15	19.65	6.68	15.03	11.49	1.65	-11.56	-18.95	4.13	2.29
327	6	0	-15	19.61	5.75	-11.67	11.49	-1.93	-12.55	13.17	3.98	2.50
322	6	0	-10	19.63	3.45	-5.71	11.49	-1.62	-13.27	7.02	4.15	2.33
316	6	0	-5	19.67	2.62	-1.64	11.49	-0.88	-13.87	2.16	4.11	2.37
293	6	0	0	19.66	2.39	2.31	11.49	0.02	-13.70	-2.54	4.19	2.29
297	6	0	5	19.65	3.08	6.23	11.49	0.85	-13.37	-7.26	4.16	2.32
301	6	0	10	19.66	4.45	10.62	11.49	1.43	-13.27	-12.83	4.15	2.33
306	6	0	15	19.67	6.90	16.00	11.49	1.75	-13.23	-19.48	4.11	2.37
368	6	10	-15	19.64	6.69	-13.28	11.49	-1.35	-9.44	14.34	3.83	2.59
362	6	10	-10	19.62	3.34	-5.35	11.49	-1.62	-11.02	6.09	4.16	2.26
358	6	10	-5	19.65	2.47	-1.89	11.49	-1.03	-12.26	2.29	4.30	2.12
333	6	10	0	19.64	2.10	1.12	11.49	-0.23	-13.51	-1.49	4.22	2.20
337	6	10	5	19.67	2.76	4.92	11.49	0.60	-14.07	-6.11	4.20	2.22
341	6	10	10	19.69	4.25	9.38	11.49	1.32	-14.49	-12.00	4.16	2.26
345	6	10	15	19.69	6.72	15.06	11.49	1.69	-14.68	-19.55	4.09	2.33
370	6	10	15	19.63	6.76	15.11	11.49	1.68	-14.65	-19.72	4.15	2.27
401	6	20	-15	19.60	4.64	-8.44	11.49	-2.16	-10.95	11.85	4.38	1.85
396	6	20	-10	19.59	3.61	-5.39	11.49	-1.58	-10.22	6.86	4.17	2.06
392	6	20	-5	19.63	2.46	-1.33	11.49	-1.21	-10.36	1.55	4.19	2.04
375	6	20	0	19.68	2.20	0.77	11.49	-0.44	-12.58	-1.04	4.38	1.85
379	6	20	5	19.64	2.27	3.12	11.49	0.46	-13.99	-4.17	4.49	1.74
380	6	20	5	19.66	2.25	3.12	11.49	0.46	-14.02	-4.23	4.49	1.74
384	6	20	10	19.64	3.05	5.64	11.49	1.33	-14.54	-7.89	4.52	1.71
388	6	20	15	19.63	4.73	9.12	11.49	2.02	-15.11	-13.05	4.47	1.76

* Indicates model was close to heave stop

TABLE 5.320.1 - STABILITY DATA IN WIND AXES WITHOUT AIR TARES

30 deg Deadrise, L/R = 0.234, Cv = 0

RUN	Trim deg	Roll deg	Yaw deg	Speed fps	X lb	Y lb	Z lb	K lb-ft	M lb-ft	N lb-ft	Heave in	TD in
1126	0	-10	-15	0.00	0.01	-0.17	11.49	-0.62	-3.30	0.03	1.92	2.17
1122	0	-10	-10	0.00	0.03	-0.29	11.49	-0.29	-3.26	0.03	1.95	2.14
1117	0	-10	-5	0.00	-0.00	-0.31	11.49	0.00	-3.29	0.04	1.95	2.14
1101	0	-10	0	0.00	0.02	-0.28	11.49	0.28	-3.23	0.05	1.97	2.12
1105	0	-10	5	0.00	-0.01	-0.25	11.49	0.56	-3.18	0.05	1.96	2.13
1110	0	-10	10	0.00	-0.03	-0.27	11.49	0.83	-3.06	0.03	1.95	2.14
1113	0	-10	15	0.00	0.02	-0.11	11.49	1.02	-2.87	0.01	1.95	2.14
1024	0	0	-15	0.00	-0.02	-0.16	11.49	-0.78	-3.06	0.03	1.86	2.29
1020	0	0	-10	0.00	0.01	-0.27	11.49	-0.46	-3.10	0.03	1.88	2.27
1016	0	0	-5	0.00	0.01	-0.25	11.49	-0.19	-3.09	0.05	1.88	2.27
1003	0	0	0	0.00	0.01	-0.04	11.49	0.04	-2.93	0.04	1.93	2.22
1085	0	0	0	0.00	-0.03	-0.32	11.49	0.07	-3.18	0.00	1.91	2.24
1007	0	0	5	0.00	-0.01	-0.20	11.49	0.34	-2.93	0.04	1.89	2.26
1011	0	0	10	0.00	-0.04	-0.31	11.49	0.59	-2.91	0.03	1.90	2.25
1014	0	0	15	0.00	-0.01	-0.15	11.49	0.78	-2.84	0.04	1.87	2.28
1058	0	10	-15	0.00	-0.00	-0.10	11.49	-1.07	-3.20	0.01	2.02	2.07
1054	0	10	-10	0.00	-0.01	-0.14	11.49	-0.80	-3.25	0.03	1.99	2.10
1050	0	10	-5	0.00	-0.01	-0.11	11.49	-0.50	-3.29	0.04	2.00	2.09
1035	0	10	0	0.00	0.01	-0.10	11.49	-0.17	-3.16	0.02	2.02	2.07
1039	0	10	5	0.00	-0.01	-0.23	11.49	0.13	-3.26	0.02	2.03	2.06
1043	0	10	10	0.00	-0.02	-0.24	11.49	0.43	-3.22	0.02	2.04	2.05
1048	0	10	15	0.00	0.00	-0.15	11.49	0.65	-3.18	0.02	2.00	2.09
1096	0	20	-15	0.00	0.05	-0.35	11.49	-1.20	-3.43	0.04	2.06	1.84
1092	0	20	-10	0.00	0.02	-0.30	11.49	-0.89	-3.49	0.02	2.05	1.85
1087	0	20	-5	0.00	0.03	-0.24	11.49	-0.58	-3.48	0.04	2.07	1.83
1063	0	20	0	0.00	0.02	-0.13	11.49	-0.31	-3.44	0.03	2.12	1.78
1067	0	20	5	0.00	0.01	-0.10	11.49	-0.03	-3.48	0.03	2.10	1.80
1072	0	20	10	0.00	-0.00	-0.24	11.49	0.33	-3.47	0.01	2.10	1.80
1076	0	20	15	0.00	-0.03	-0.26	11.49	0.63	-3.41	0.02	2.11	1.79
832	3	-10	-15	0.00	-0.02	-0.11	11.49	-1.86	-8.16	0.04	2.13	3.13
828	3	-10	-10	0.00	-0.03	-0.20	11.49	-1.16	-8.35	0.06	2.11	3.15
824	3	-10	-5	0.00	-0.03	-0.20	11.49	-0.37	-8.40	0.03	2.12	3.14
800	3	-10	0	0.00	-0.04	-0.22	11.49	0.36	-8.36	0.05	2.20	3.06
816	3	-10	10	0.00	-0.06	-0.21	11.49	1.80	-8.14	0.01	2.12	3.14
820	3	-10	15	0.00	-0.06	-0.24	11.49	2.52	-8.01	0.01	2.10	3.16
692	3	0	-15	0.00	-0.04	-0.07	11.49	-2.09	-8.12	0.05	2.11	3.21
688	3	0	-10	0.00	-0.02	-0.21	11.49	-1.39	-8.31	0.06	2.10	3.22
699	3	0	-10	0.00	-0.04	-0.06	11.49	-1.37	-8.29	0.06	2.09	3.23
684	3	0	-5	0.00	-0.06	-0.06	11.49	-0.65	-8.33	0.02	2.12	3.20
704	3	0	-5	0.00	-0.04	-0.16	11.49	-0.67	-8.46	0.07	2.07	3.25
657	3	0	0	0.00	-0.04	-0.06	11.49	0.08	-8.30	0.04	2.09	3.23
708	3	0	0	0.00	-0.02	-0.09	11.49	0.07	-8.32	0.04	2.10	3.22
661	3	0	5	0.00	-0.04	-0.07	11.49	0.80	-8.32	0.06	2.08	3.24
712	3	0	5	0.00	-0.04	-0.12	11.49	0.79	-8.28	0.04	2.10	3.22
675	3	0	10	0.00	-0.03	-0.09	11.49	1.52	-8.22	0.01	2.12	3.20
718	3	0	10	0.00	-0.03	-0.02	11.49	1.54	-8.26	0.05	2.07	3.25
679	3	0	15	0.00	-0.02	-0.09	11.49	2.23	-8.04	0.01	2.10	3.22
722	3	0	15	0.00	-0.06	-0.15	11.49	2.21	-8.03	0.04	2.08	3.24

* Indicates model was close to heave stop

TABLE 5.320.2 - STABILITY DATA IN WIND AXES WITHOUT AIR TARES

30 deg Deadrise, L/R = 0.234, Cv = 0

RUN	Trim deg	Roll deg	Yaw deg	Speed fps	X lb	Y lb	Z lb	K lb-ft	M lb-ft	N lb-ft	Heave in	TD in
764	3	10	-15	0.00	-0.03	-0.16	11.49	-2.34	-8.16	0.05	2.20	3.06
760	3	10	-10	0.00	-0.04	-0.08	11.49	-1.60	-8.23	0.04	2.21	3.05
756	3	10	-5	0.00	-0.03	-0.23	11.49	-0.85	-8.42	0.04	2.19	3.07
726	3	10	0	0.00	-0.03	-0.11	11.49	-0.15	-8.42	0.03	2.13	3.13
752	3	10	5	0.00	-0.03	-0.12	11.49	0.57	-8.32	0.04	2.18	3.08
730	3	10	10	0.00	-0.05	-0.11	11.49	1.31	-8.29	0.03	2.11	3.15
743	3	10	10	0.00	0.01	-0.12	11.49	1.28	-8.15	0.02	2.18	3.08
748	3	10	15	0.00	-0.06	-0.25	11.49	2.05	-8.06	-0.01	2.17	3.09
795	3	20	-15	0.00	-0.01	-0.18	11.49	-2.49	-8.20	0.03	2.27	2.80
791	3	20	-10	0.00	-0.03	-0.12	11.49	-1.77	-8.34	0.04	2.27	2.80
787	3	20	-5	0.00	-0.05	-0.09	11.49	-1.03	-8.39	0.05	2.27	2.80
771	3	20	0	0.00	-0.02	-0.33	11.49	-0.27	-8.50	0.03	2.26	2.81
775	3	20	5	0.00	-0.03	-0.24	11.49	0.49	-8.49	0.02	2.26	2.81
779	3	20	10	0.00	-0.05	-0.23	11.49	1.23	-8.40	0.03	2.26	2.81
783	3	20	15	0.00	-0.06	-0.24	11.49	1.91	-8.26	0.02	2.25	2.82
994	6	-10	-15	0.00	-0.05	-0.11	11.49	-2.64	-11.04	0.04	2.47	3.95
989	6	-10	-10	0.00	-0.04	-0.12	11.49	-1.67	-11.27	0.07	2.47	3.95
985	6	-10	-5	0.00	-0.05	-0.13	11.49	-0.68	-11.36	0.04	2.47	3.95
962	6	-10	0	0.00	-0.05	-0.07	11.49	0.31	-11.38	0.06	2.46	3.96
965	6	-10	5	0.00	-0.04	-0.07	11.49	1.30	-11.30	0.09	2.46	3.96
977	6	-10	10	0.00	-0.02	-0.07	11.49	2.28	-11.12	0.05	2.47	3.95
981	6	-10	15	0.00	-0.04	-0.07	11.49	3.21	-10.78	0.05	2.47	3.95
864	6	0	-15	0.00	-0.03	-0.10	11.49	-2.88	-11.14	0.05	2.42	4.06
860	6	0	-10	0.00	-0.06	-0.11	11.49	-1.91	-11.38	0.07	2.41	4.07
856	6	0	-5	0.00	-0.04	-0.10	11.49	-0.92	-11.50	0.04	2.40	4.08
839	6	0	0	0.00	-0.03	-0.04	11.49	0.10	-11.46	0.06	2.45	4.03
844	6	0	5	0.00	-0.03	-0.05	11.49	1.10	-11.45	0.07	2.40	4.08
848	6	0	10	0.00	-0.04	-0.10	11.49	2.09	-11.30	0.06	2.41	4.07
852	6	0	15	0.00	-0.02	-0.09	11.49	3.06	-11.02	0.03	2.40	4.08
923	6	10	-15	0.00	-0.04	-0.11	11.49	-3.07	-11.04	0.04	2.50	3.92
919	6	10	-10	0.00	-0.03	-0.11	11.49	-2.10	-11.28	0.04	2.49	3.93
915	6	10	-5	0.00	-0.03	-0.08	11.49	-1.11	-11.40	0.05	2.49	3.93
869	6	10	0	0.00	-0.03	-0.12	11.49	-0.11	-11.44	0.08	2.44	3.98
881	6	10	0	0.00	-0.01	-0.04	11.49	-0.11	-11.45	0.07	2.53	3.89
912	6	10	0	0.00	-0.02	-0.12	11.49	-0.11	-11.50	0.06	2.50	3.92
888	6	10	5	0.00	-0.03	-0.04	11.49	0.88	-11.38	0.08	2.50	3.92
892	6	10	10	0.00	-0.03	-0.07	11.49	1.86	-11.24	0.06	2.49	3.93
898	6	10	15	0.00	-0.03	-0.08	11.49	2.86	-11.12	0.05	2.48	3.94
913	6	10	15	0.00	-0.01	-0.03	11.49	2.82	-11.00	0.04	2.50	3.92
955	6	20	-15	0.00	-0.05	-0.14	11.49	-3.21	-10.95	0.04	2.54	3.69
951	6	20	-10	0.00	-0.04	-0.14	11.49	-2.26	-11.28	0.06	2.54	3.69
946	6	20	-5	0.00	-0.04	-0.10	11.49	-1.28	-11.44	0.06	2.53	3.70
928	6	20	0	0.00	-0.04	-0.08	11.49	-0.27	-11.52	0.07	2.53	3.70
932	6	20	5	0.00	-0.03	-0.05	11.49	0.73	-11.39	0.08	2.55	3.68
936	6	20	10	0.00	-0.02	-0.08	11.49	1.71	-11.29	0.06	2.52	3.71
943	6	20	15	0.00	-0.04	-0.10	11.49	2.70	-11.16	0.04	2.52	3.71

* Indicates model was close to heave stop

TABLE 5.321.1 - STABILITY DATA IN WIND AXES WITHOUT AIR TARES

30 deg Deadrise, L/R = 0.234, Cv = 1.5

RUN	Trim deg	Roll deg	Yaw deg	Speed fps	X lb	Y lb	Z lb	K lb-ft	M lb-ft	N lb-ft	Heave in	TD in
1127	0	-10	-15	7.35	3.67	-6.90	11.49	0.74	0.83	-7.91	1.04	3.05
1129 *	0	-10	-15	7.36	3.93	-7.45	11.49	0.76	0.88	-8.93	0.87	3.22
1123	0	-10	-10	7.36	2.01	-3.17	11.49	0.51	0.24	-4.76	1.46	2.63
1118	0	-10	-5	7.36	1.29	-1.21	11.49	0.34	-0.08	-2.63	1.65	2.44
1102	0	-10	0	7.36	1.13	-0.12	11.49	0.24	0.38	-1.13	1.72	2.37
1106	0	-10	5	7.36	1.25	0.70	11.49	0.11	1.11	-0.42	1.66	2.43
1111	0	-10	10	7.36	1.93	2.37	11.49	-0.22	2.14	0.12	1.47	2.62
1114	0	-10	15	7.36	2.97	4.34	11.49	-0.65	2.52	1.90	1.28	2.81
1025	0	0	-15	7.35	3.81	-7.84	11.49	0.26	0.79	-8.51	1.07	3.08
1021	0	0	-10	7.35	2.07	-3.59	11.49	0.31	0.80	-4.88	1.45	2.70
1017	0	0	-5	7.35	1.40	-1.30	11.49	0.14	0.40	-2.90	1.60	2.55
1004	0	0	0	7.37	1.16	-0.06	11.49	0.04	0.68	-1.49	1.66	2.49
1008	0	0	5	7.37	1.32	0.80	11.49	-0.11	1.42	-0.63	1.57	2.58
1012	0	0	10	7.36	1.99	2.43	11.49	-0.53	2.76	-0.10	1.39	2.76
1015 *	0	0	15	7.35	4.03	6.61	11.49	-1.45	5.22	0.76	0.87	3.28
1059	0	10	-15	7.36	3.71	-5.62	11.49	0.92	2.69	-7.09	1.20	2.89
1055	0	10	-10	7.35	2.06	-3.43	11.49	0.23	1.01	-4.84	1.55	2.54
1051	0	10	-5	7.36	1.47	-1.40	11.49	0.00	0.63	-2.99	1.67	2.42
1036	0	10	0	7.37	1.22	-0.20	11.49	-0.13	0.71	-1.60	1.76	2.33
1040	0	10	5	7.36	1.32	0.66	11.49	-0.37	1.25	-0.74	1.71	2.38
1044	0	10	10	7.35	1.90	2.13	11.49	-0.84	2.62	-0.06	1.51	2.58
1045	0	10	10	7.37	1.98	2.33	11.49	-0.89	2.69	-0.03	1.49	2.60
1049	0	10	15	7.36	3.76	5.78	11.49	-1.91	5.41	0.77	0.98	3.11
1097	0	20	-15	7.37	3.78	-5.38	11.49	0.73	2.31	-6.81	1.17	2.73
1093	0	20	-10	7.36	2.05	-2.57	11.49	0.04	0.71	-4.04	1.56	2.34
1088	0	20	-5	7.37	1.43	-1.22	11.49	-0.14	0.42	-2.65	1.76	2.14
1064	0	20	0	7.36	1.24	-0.21	11.49	-0.28	0.49	-1.59	1.83	2.07
1068	0	20	5	7.38	1.34	0.60	11.49	-0.51	1.10	-0.80	1.77	2.13
1071	0	20	10	7.36	1.85	1.90	11.49	-1.06	2.42	-0.08	1.56	2.34
1073	0	20	10	7.36	1.88	2.06	11.49	-1.08	2.48	-0.10	1.56	2.34
1077	0	20	15	7.35	3.38	4.96	11.49	-2.12	4.84	1.10	1.18	2.72
833	3	-10	-15	7.37	2.57	-4.50	11.49	-0.72	-4.29	-1.88	1.75	3.51
829	3	-10	-10	7.36	1.61	-1.94	11.49	-0.52	-5.27	-1.32	1.93	3.33
825	3	-10	-5	7.37	1.21	-0.29	11.49	-0.12	-5.43	-0.92	2.02	3.24
801	3	-10	0	7.36	1.18	0.62	11.49	0.32	-5.10	-0.85	2.08	3.18
813	3	-10	5	7.38	1.39	1.77	11.49	0.63	-4.25	-1.21	1.96	3.30
817	3	-10	10	7.39	2.16	3.96	11.49	0.61	-2.78	-2.23	1.79	3.47
821	3	-10	15	7.38	3.91	7.70	11.49	0.37	-1.06	-3.67	1.49	3.77
698	3	0	-15	7.36	2.94	-5.41	11.49	-1.06	-3.84	-2.49	1.65	3.67
689	3	0	-10	7.36	1.53	-2.07	11.49	-0.75	-4.75	-1.41	2.07	3.25
700	3	0	-10	7.36	1.68	-2.15	11.49	-0.76	-4.86	-1.71	1.89	3.43
685	3	0	-5	7.35	1.22	-0.50	11.49	-0.36	-5.27	-1.30	2.05	3.27
705	3	0	-5	7.36	1.29	-0.65	11.49	-0.39	-5.33	-1.32	1.98	3.34
658	3	0	0	7.36	1.17	0.48	11.49	0.11	-5.21	-1.05	2.00	3.32
711	3	0	0	7.36	1.20	0.51	11.49	0.10	-5.17	-1.08	2.01	3.31
662	3	0	5	7.35	1.33	1.47	11.49	0.51	-4.69	-1.19	1.92	3.40
713	3	0	5	7.36	1.33	1.53	11.49	0.51	-4.66	-1.18	1.94	3.38
676	3	0	10	7.36	2.02	3.46	11.49	0.63	-3.53	-1.94	1.83	3.49
719	3	0	10	7.38	2.07	3.62	11.49	0.63	-3.45	-1.88	1.76	3.56

* Indicates model was close to heave stop

TABLE 5.321.2 - STABILITY DATA IN WIND AXES WITHOUT AIR TARES

30 deg Deadrise, L/R = 0.234, Cv = 1.5

RUN	Trim deg	Roll deg	Yaw deg	Speed fps	X lb	Y lb	Z lb	K lb-ft	M lb-ft	N lb-ft	Heave in	TD in
680	3	0	15	7.35	3.74	7.29	11.49	0.21	-1.20	-3.38	1.48	3.84
723	3	0	15	7.36	3.78	7.33	11.49	0.19	-1.15	-3.31	1.42	3.90
765	3	10	-15	7.35	2.63	-4.45	11.49	-0.91	-2.67	-1.59	1.92	3.34
761	3	10	-10	7.36	1.75	-2.33	11.49	-0.97	-4.40	-1.45	2.03	3.23
757	3	10	-5	7.35	1.30	-0.73	11.49	-0.64	-4.96	-1.30	2.11	3.15
727	3	10	0	7.36	1.20	0.37	11.49	-0.20	-5.21	-1.17	2.05	3.21
753	3	10	5	7.36	1.35	1.21	11.49	0.19	-4.80	-1.38	2.04	3.22
731	3	10	10	7.35	1.87	3.00	11.49	0.36	-3.76	-1.97	1.80	3.46
749	3	10	15	7.37	3.35	6.28	11.49	0.05	-1.65	-2.95	1.58	3.68
796	3	20	-15	7.35	2.36	-3.14	11.49	-0.76	-2.03	-0.83	1.91	3.16
792	3	20	-10	7.35	1.65	-1.86	11.49	-1.03	-4.02	-0.94	2.12	2.95
788	3	20	-5	7.35	1.27	-0.69	11.49	-0.77	-4.88	-1.04	2.18	2.89
772	3	20	0	7.37	1.21	0.33	11.49	-0.38	-4.98	-1.16	2.19	2.88
776	3	20	5	7.35	1.37	1.30	11.49	-0.05	-4.59	-1.48	2.14	2.93
780	3	20	10	7.35	1.84	2.88	11.49	0.09	-3.77	-2.13	1.98	3.09
784	3	20	15	7.34	3.03	5.31	11.49	-0.24	-1.79	-3.10	1.69	3.38
995	6	-10	-15	7.35	2.44	-3.18	11.49	-1.71	-8.31	1.70	2.41	4.01
990	6	-10	-10	7.35	1.79	-1.43	11.49	-1.20	-8.88	0.74	2.54	3.88
991	6	-10	-10	7.35	1.83	-1.43	11.49	-1.20	-8.88	0.70	2.53	3.89
986	6	-10	-5	7.36	1.53	-0.18	11.49	-0.46	-8.89	-0.09	2.59	3.83
960	6	-10	0	7.37	1.49	0.96	11.49	0.27	-8.67	-0.97	2.53	3.89
961	6	-10	0	7.35	1.47	0.89	11.49	0.26	-8.69	-0.98	2.54	3.88
966	6	-10	5	7.36	1.75	2.32	11.49	0.84	-8.01	-2.19	2.47	3.95
978	6	-10	10	7.37	2.53	4.66	11.49	1.14	-7.08	-4.35	2.33	4.09
982	6	-10	15	7.36	4.26	8.43	11.49	1.07	-5.48	-7.28	2.01	4.41
865	6	0	-15	7.35	2.62	-3.67	11.49	-1.88	-8.07	1.62	2.36	4.12
861	6	0	-10	7.35	1.84	-1.62	11.49	-1.44	-8.85	0.46	2.46	4.02
857	6	0	-5	7.35	1.59	-0.44	11.49	-0.74	-9.20	-0.28	2.50	3.98
840	6	0	0	7.39	1.51	0.80	11.49	0.06	-9.11	-1.06	2.52	3.96
845	6	0	5	7.37	1.76	2.10	11.49	0.75	-8.62	-2.13	2.42	4.06
849	6	0	10	7.36	2.45	4.17	11.49	1.12	-7.67	-3.85	2.27	4.21
853	6	0	15	7.35	4.04	7.76	11.49	1.05	-6.00	-6.58	1.97	4.51
924	6	10	-15	7.35	2.66	-3.83	11.49	-1.97	-7.50	1.88	2.45	3.97
920	6	10	-10	7.35	1.90	-1.74	11.49	-1.57	-8.36	0.51	2.56	3.86
916	6	10	-5	7.35	1.52	-0.26	11.49	-0.95	-8.79	-0.38	2.62	3.80
870	6	10	0	7.36	1.54	0.76	11.49	-0.21	-8.88	-1.22	2.53	3.89
871	6	10	0	7.35	1.55	0.72	11.49	-0.23	-9.06	-1.26	2.55	3.87
889	6	10	5	7.35	1.72	2.03	11.49	0.49	-8.61	-2.18	2.55	3.87
893	6	10	10	7.36	2.20	3.62	11.49	0.99	-7.74	-3.53	2.45	3.97
894	6	10	10	7.35	2.28	3.73	11.49	0.99	-7.81	-3.63	2.45	3.97
899	6	10	15	7.34	3.52	6.38	11.49	1.06	-6.52	-5.79	2.19	4.23
956	6	20	-15	7.36	2.51	-3.17	11.49	-1.92	-6.81	2.15	2.49	3.74
952	6	20	-10	7.35	1.89	-1.66	11.49	-1.66	-8.07	0.88	2.62	3.61
947	6	20	-5	7.36	1.53	-0.22	11.49	-1.11	-8.51	-0.25	2.67	3.56
929	6	20	0	7.36	1.53	0.90	11.49	-0.45	-8.64	-1.31	2.65	3.58
933	6	20	5	7.36	1.79	2.30	11.49	0.17	-8.34	-2.61	2.58	3.65
937	6	20	10	7.36	2.24	3.78	11.49	0.69	-7.49	-3.95	2.50	3.73
941	6	20	15	7.35	3.28	5.71	11.49	0.95	-6.61	-5.58	2.35	3.88
942	6	20	15	7.35	3.20	5.55	11.49	0.96	-6.66	-5.57	2.38	3.85

* Indicates model was close to heave stop

TABLE 5.323.1 - STABILITY DATA IN WIND AXES WITHOUT AIR TARES

30 deg Deadrise, L/R = 0.234, Cv = 3

RUN	Trim deg	Roll deg	Yaw deg	Speed fps	X lb	Y lb	Z lb	K lb-ft	M lb-ft	N lb-ft	Heave in	TD in	
1128	*	0	-10	-15	14.69	14.53	-29.38	11.49	1.03	2.20	-28.61	0.78	3.31
1124	0	-10	-10	14.74	7.75	-13.97	11.49	1.36	2.89	-18.22	1.17	2.92	
1120	0	-10	-5	14.75	3.92	-5.09	11.49	0.64	1.66	-8.72	1.80	2.29	
1103	0	-10	0	14.74	3.10	-0.51	11.49	0.30	1.34	-3.38	1.90	2.19	
1108	0	-10	5	14.71	3.87	3.80	11.49	-0.13	3.35	-2.24	1.77	2.32	
1112	0	-10	10	14.73	9.35	17.28	11.49	-1.46	7.57	-4.03	0.90	3.19	
1115	0	-10	15	14.73	3.70	6.07	11.49	1.54	-2.77	0.69	2.90	1.19	
1026	0	0	-15	14.73	6.01	-10.75	11.49	3.22	14.64	-11.94	2.49	1.66	
1022	0	0	-10	14.71	7.66	-15.05	11.49	0.85	1.15	-18.21	1.28	2.87	
1018	0	0	-5	14.74	4.07	-5.21	11.49	0.47	1.86	-9.75	1.75	2.40	
1005	0	0	0	14.75	3.27	-0.52	11.49	0.12	2.55	-5.01	1.81	2.34	
1009	0	0	5	14.77	3.87	3.80	11.49	-0.33	5.20	-2.72	1.67	2.48	
1013	*	0	0	10	14.72	9.75	17.78	11.49	-1.71	8.59	-4.10	0.80	3.35
1060	0	10	-15	14.73	3.74	-5.00	11.49	2.12	10.25	-5.23	3.01	1.08	
1056	0	10	-10	14.73	6.58	-12.60	11.49	1.27	5.00	-14.82	1.73	2.36	
1052	0	10	-5	14.73	4.52	-5.18	11.49	0.31	2.14	-8.15	1.88	2.21	
1037	0	10	0	14.73	3.69	-0.54	11.49	-0.11	1.91	-4.44	1.94	2.15	
1041	0	10	5	14.77	4.10	4.04	11.49	-0.46	4.62	-2.94	1.78	2.31	
1046	0	10	10	14.74	8.80	15.93	11.49	-1.61	8.19	-2.98	1.08	3.01	
1098	0	20	-15	14.75	8.16	-11.51	11.49	4.57	17.35	-10.76	2.05	1.85	
1094	0	20	-10	14.74	6.26	-8.19	11.49	2.28	13.65	-9.28	1.82	2.08	
1089	0	20	-5	14.78	4.09	-4.85	11.49	0.23	2.68	-7.22	1.95	1.95	
1065	0	20	0	14.74	3.58	-0.83	11.49	-0.28	2.02	-4.23	2.00	1.90	
1069	0	20	5	14.78	4.12	3.50	11.49	-0.71	3.22	-2.52	1.89	2.01	
1074	0	20	10	14.73	7.38	12.97	11.49	-1.51	6.64	-0.59	1.45	2.45	
1078	*	0	20	15	14.73	14.45	28.46	11.49	-3.69	13.14	-1.44	0.86	3.04
834	3	-10	-15	14.75	8.12	-17.81	11.49	0.36	0.46	-7.31	1.85	3.41	
830	3	-10	-10	14.72	4.19	-7.11	11.49	-0.13	-3.46	-3.68	2.15	3.11	
826	3	-10	-5	14.72	2.80	-1.45	11.49	0.04	-4.17	-2.39	2.30	2.96	
802	3	-10	0	14.75	2.76	2.32	11.49	0.39	-3.76	-2.49	2.38	2.88	
814	3	-10	5	14.78	3.39	6.25	11.49	0.46	-2.67	-4.45	2.38	2.88	
818	3	-10	10	14.77	6.08	14.90	11.49	-0.33	1.30	-9.89	2.11	3.15	
822	3	-10	15	14.73	4.22	8.52	11.49	3.27	-10.93	-7.89	3.39	1.87	
697	3	0	-15	14.74	8.87	-19.66	11.49	0.29	2.82	-5.97	1.90	3.42	
690	3	0	-10	14.71	4.80	-8.65	11.49	-0.35	-1.54	-5.55	2.08	3.24	
701	3	0	-10	14.73	4.43	-7.71	11.49	-0.38	-2.02	-4.54	2.17	3.15	
706	3	0	-5	14.72	2.87	-1.93	11.49	-0.32	-4.40	-3.33	2.35	2.97	
659	3	0	0	14.75	2.86	1.79	11.49	0.10	-4.38	-3.71	2.21	3.11	
710	3	0	0	14.69	2.63	1.71	11.49	0.12	-4.59	-3.11	2.44	2.88	
663	3	0	5	14.74	3.41	6.35	11.49	0.40	-2.66	-4.82	2.20	3.12	
714	3	0	5	14.74	3.15	5.90	11.49	0.39	-3.06	-4.52	2.36	2.96	
677	3	0	10	14.72	6.05	14.43	11.49	-0.26	1.09	-8.75	2.07	3.25	
720	3	0	10	14.73	6.13	14.57	11.49	-0.29	1.31	-8.62	2.01	3.31	
724	3	0	15	14.75	14.25	33.96	11.49	-3.63	12.52	-14.60	1.20	4.12	

* Indicates model was close to heave stop

TABLE 5.323.2 - STABILITY DATA IN WIND AXES WITHOUT AIR TARES

30 deg Deadrise, L/R = 0.234, Cv = 3

RUN	Trim deg	Roll deg	Yaw deg	Speed fps	X lb	Y lb	Z lb	K lb-ft	M lb-ft	N lb-ft	Heave in	TD in
766	3	10	-15	14.72	3.30	-4.92	11.49	-1.06	-2.93	1.18	3.19	2.07
762	3	10	-10	14.74	4.70	-7.69	11.49	-0.43	-0.18	-3.71	2.24	3.02
758	3	10	-5	14.72	2.95	-1.96	11.49	-0.55	-2.92	-3.40	2.43	2.83
728	3	10	0	14.71	2.48	1.66	11.49	-0.20	-4.53	-3.39	2.53	2.73
754	3	10	5	14.72	2.88	5.10	11.49	0.23	-4.19	-4.90	2.53	2.73
732	3	10	10	14.71	4.84	11.12	11.49	0.08	-1.75	-7.30	2.26	3.00
744	3	10	10	14.77	4.85	11.21	11.49	0.05	-1.61	-7.48	2.30	2.96
750	3	10	15	14.73	11.12	25.51	11.49	-2.54	7.90	-12.62	1.69	3.57
797	3	20	-15	14.69	3.27	-4.38	11.49	-0.81	-1.08	2.38	3.07	2.00
793	3	20	-10	14.69	3.41	-4.23	11.49	-0.27	1.37	0.05	2.63	2.44
789	3	20	-5	14.72	2.99	-1.73	11.49	-0.72	-2.64	-2.09	2.50	2.57
773	3	20	0	14.72	2.48	1.74	11.49	-0.55	-3.57	-3.60	2.58	2.49
777	3	20	5	14.69	2.75	4.52	11.49	-0.13	-4.28	-5.22	2.73	2.34
781	3	20	10	14.71	4.08	9.14	11.49	0.06	-4.26	-8.57	2.71	2.36
785	3	20	15	14.74	6.82	15.59	11.49	-0.29	-3.26	-12.99	2.65	2.42
996	6	-10	-15	14.72	3.95	-6.30	11.49	-1.82	-10.11	5.69	3.49	2.93
992	6	-10	-10	14.72	2.58	-2.56	11.49	-1.23	-10.02	2.34	3.57	2.85
987	6	-10	-5	14.75	1.68	0.32	11.49	-0.45	-9.16	-0.29	3.63	2.79
963	6	-10	0	14.73	2.15	2.96	11.49	0.23	-8.12	-2.80	3.35	3.07
967	6	-10	5	14.73	3.06	7.11	11.49	0.47	-7.69	-7.45	3.35	3.07
979	6	-10	10	14.73	4.63	12.12	11.49	0.29	-6.68	-13.11	3.34	3.08
983	6	-10	15	14.73	9.97	25.23	11.49	-1.56	-1.60	-24.50	2.77	3.65
866	6	0	-15	14.74	4.59	-7.73	11.49	-1.52	-7.82	4.62	3.15	3.33
862	6	0	-10	14.73	2.76	-3.14	11.49	-1.47	-9.61	1.87	3.42	3.06
858	6	0	-5	14.73	2.17	-0.06	11.49	-0.75	-10.03	-0.49	3.53	2.95
842	6	0	0	14.74	1.94	2.75	11.49	0.04	-9.86	-3.09	3.57	2.91
846	6	0	5	14.74	2.79	6.00	11.49	0.65	-9.01	-6.03	3.43	3.05
850	6	0	10	14.74	4.56	11.13	11.49	0.67	-7.66	-11.34	3.31	3.17
854	6	0	15	14.70	9.21	22.41	11.49	-0.93	-3.05	-20.78	2.73	3.75
925	6	10	-15	14.74	5.01	-8.61	11.49	-1.31	-6.28	6.04	3.15	3.27
921	6	10	-10	14.77	2.69	-2.70	11.49	-1.44	-7.79	1.37	3.48	2.94
917	6	10	-5	14.78	2.02	-0.19	11.49	-0.99	-9.35	-0.64	3.70	2.72
882	6	10	0	14.75	1.95	2.33	11.49	-0.28	-10.23	-3.17	3.80	2.62
883	6	10	0	14.73	1.92	2.36	11.49	-0.29	-10.53	-3.31	3.73	2.69
884	6	10	0	14.72	2.07	2.30	11.49	-0.29	-10.52	-3.30	3.73	2.69
885	6	10	0	14.71	1.95	2.33	11.49	-0.28	-10.22	-3.17	3.81	2.61
886	6	10	0	14.73	1.98	2.36	11.49	-0.29	-10.43	-3.32	3.73	2.69
890	6	10	5	14.71	2.54	5.37	11.49	0.47	-10.99	-6.51	3.74	2.68
895	6	10	10	14.69	3.83	8.90	11.49	1.00	-10.77	-10.65	3.72	2.70
896	6	10	10	14.73	3.86	9.24	11.49	1.05	-10.98	-10.81	3.69	2.73
900	6	10	15	14.77	6.39	14.87	11.49	1.05	-9.69	-16.16	3.47	2.95
957	6	20	-15	14.74	4.63	-8.16	11.49	-1.41	-6.57	7.65	3.36	2.87
953	6	20	-10	14.73	2.86	-2.94	11.49	-1.47	-7.33	2.19	3.48	2.75
948	6	20	-5	14.75	1.88	0.18	11.49	-1.16	-8.19	-0.86	3.66	2.57
930	6	20	0	14.73	1.99	2.02	11.49	-0.53	-9.76	-3.02	3.85	2.38
934	6	20	5	14.78	2.17	4.12	11.49	0.19	-11.02	-5.67	3.96	2.27
939	6	20	10	14.72	3.19	6.77	11.49	0.94	-12.02	-9.30	3.98	2.25
944	6	20	15	14.75	4.94	10.35	11.49	1.54	-12.52	-14.03	3.95	2.28

* Indicates model was close to heave stop

TABLE 5.324.1 - STABILITY DATA IN WIND AXES WITHOUT AIR TARES

30 deg Deadrise, L/R = 0.234, Cv = 4

RUN	Trim deg	Roll deg	Yaw deg	Speed fps	X lb	Y lb	Z lb	K lb-ft	M lb-ft	N lb-ft	Heave in	TD in	
1125	*	0	-10	-10	19.69	13.50	-21.40	11.49	2.05	4.70	-35.85	0.75	3.34
1121		0	-10	-5	19.68	6.74	-8.82	11.49	1.15	6.14	-16.88	1.70	2.39
1104		0	-10	0	19.60	5.10	-0.64	11.49	0.31	4.81	-6.48	1.85	2.24
1109		0	-10	5	19.59	7.80	9.23	11.49	-0.64	8.28	-8.20	1.45	2.64
1116		0	-10	15	19.66	3.29	6.35	11.49	1.80	-6.09	-0.80	3.37	0.72
1027		0	0	-15	19.61	4.66	-9.88	11.49	1.46	6.37	-5.44	3.23	0.92
1023	*	0	0	-10	19.60	12.95	-16.01	11.49	1.26	2.36	-38.13	0.72	3.43
1019		0	0	-5	19.59	7.02	-8.82	11.49	1.07	5.18	-18.55	1.64	2.51
1006		0	0	0	19.53	5.39	-0.94	11.49	0.21	5.39	-8.98	1.79	2.36
1010		0	0	5	19.63	6.71	7.36	11.49	-0.65	9.82	-5.52	1.63	2.52
1061		0	10	-15	19.63	4.16	-6.27	11.49	1.18	5.79	-3.96	3.37	0.72
1057		0	10	-10	19.61	11.37	-20.42	11.49	2.96	13.41	-28.00	1.73	2.36
1053		0	10	-5	19.61	7.89	-9.12	11.49	1.00	5.86	-17.56	1.69	2.40
1038		0	10	0	19.67	6.20	0.05	11.49	-0.01	4.47	-8.32	1.87	2.22
1042		0	10	5	19.68	6.45	7.27	11.49	-0.56	9.13	-5.76	1.81	2.28
1047	*	0	10	10	19.68	16.39	28.66	11.49	-2.09	12.29	-6.52	0.80	3.29
1099		0	20	-15	19.70	6.51	-8.04	11.49	3.82	15.43	-4.77	2.87	1.03
1095		0	20	-10	19.67	9.04	-11.19	11.49	3.98	24.59	-15.01	1.99	1.91
1091		0	20	-5	19.67	6.71	-7.89	11.49	0.83	7.50	-13.21	1.93	1.97
1066		0	20	0	19.59	6.23	-0.87	11.49	-0.20	4.66	-7.80	1.96	1.94
1070		0	20	5	19.59	7.03	7.07	11.49	-0.74	6.22	-5.37	1.86	2.04
1075		0	20	10	19.70	11.57	21.93	11.49	-2.13	12.64	-1.69	1.56	2.34
835		3	-10	-15	19.70	13.49	-30.86	11.49	1.40	5.39	-13.59	1.82	3.44
831		3	-10	-10	19.66	6.58	-11.91	11.49	0.18	-2.02	-6.28	2.19	3.07
827		3	-10	-5	19.59	4.27	-2.13	11.49	0.20	-2.92	-3.97	2.36	2.90
803		3	-10	0	19.70	3.89	4.67	11.49	0.49	-1.35	-4.83	2.43	2.83
815		3	-10	5	19.67	5.53	11.45	11.49	0.23	-0.21	-8.18	2.43	2.83
819		3	-10	10	19.68	9.43	24.49	11.49	-1.12	4.76	-16.83	2.27	2.99
823		3	-10	15	19.68	3.50	7.74	11.49	4.69	-17.30	-9.28	3.94	1.32
696		3	0	-15	19.75	14.81	-33.90	11.49	1.59	10.00	-11.16	1.87	3.45
702		3	0	-10	19.54	6.79	-12.77	11.49	-0.01	0.96	-8.05	2.20	3.12
703		3	0	-10	19.54	6.88	-12.88	11.49	-0.01	1.10	-8.25	2.19	3.13
707		3	0	-5	19.68	4.24	-2.69	11.49	-0.22	-3.47	-5.28	2.41	2.91
660		3	0	0	19.60	4.54	3.02	11.49	0.15	-2.60	-6.07	2.21	3.11
709		3	0	0	19.63	3.83	3.32	11.49	0.22	-3.88	-4.84	2.49	2.83
664		3	0	5	19.65	5.56	11.71	11.49	0.30	-0.17	-8.81	2.22	3.10
715		3	0	5	19.63	4.77	10.73	11.49	0.37	-2.02	-8.64	2.48	2.84
678		3	0	10	19.73	9.52	25.05	11.49	-0.99	5.11	-15.63	2.17	3.15
721		3	0	10	19.68	9.67	25.14	11.49	-1.03	5.36	-15.51	2.11	3.21

* Indicates model was close to heave stop

TABLE 5.324.2 - STABILITY DATA IN WIND AXES WITHOUT AIR TARES
30 deg Deadrise, L/R = 0.234, Cv = 4

RUN	Trim deg	Roll deg	Yaw deg	Speed fps	X lb	Y lb	Z lb	K lb-ft	M lb-ft	N lb-ft	Heave in	TD in
767	3	10	-15	19.76	3.88	-5.81	11.49	-2.43	-7.73	3.27	3.45	1.81
768	3	10	-15	19.65	3.81	-5.92	11.49	-2.44	-8.02	3.26	3.47	1.79
763	3	10	-10	19.60	6.46	-11.17	11.49	-0.01	4.03	-5.40	2.40	2.86
759	3	10	-5	19.61	4.25	-2.65	11.49	-0.53	-0.90	-5.93	2.47	2.79
729	3	10	0	19.74	3.36	3.54	11.49	-0.18	-5.25	-5.56	2.64	2.62
755	3	10	5	19.67	4.24	9.31	11.49	0.36	-5.33	-8.67	2.68	2.58
746	3	10	10	19.75	7.11	18.89	11.49	0.16	-2.60	-13.40	2.54	2.72
747	3	10	10	19.69	7.05	18.50	11.49	0.16	-2.59	-13.31	2.55	2.71
751	3	10	15	19.76	17.00	41.28	11.49	-3.95	13.27	-20.43	1.91	3.35
798	3	20	-15	19.62	3.72	-4.74	11.49	-2.14	-5.47	4.06	3.37	1.70
794	3	20	-10	19.64	4.29	-4.54	11.49	-0.62	1.35	0.45	2.85	2.22
790	3	20	-5	19.65	4.11	-1.74	11.49	-0.72	0.20	-4.37	2.52	2.55
774	3	20	0	19.68	3.07	3.19	11.49	-0.66	-3.81	-5.07	2.79	2.28
778	3	20	5	19.61	3.70	7.51	11.49	-0.19	-6.24	-8.35	2.95	2.12
782	3	20	10	19.61	5.59	13.39	11.49	0.11	-7.38	-13.77	3.01	2.06
786	3	20	15	19.76	9.28	22.59	11.49	-0.11	-7.59	-21.93	2.99	2.08
997	6	-10	-15	19.69	5.21	-8.12	11.49	-2.61	-15.04	9.52	3.87	2.55
993	6	-10	-10	19.64	3.28	-2.95	11.49	-1.72	-14.39	3.71	3.97	2.45
988	6	-10	-5	19.66	2.19	1.27	11.49	-0.73	-13.25	-0.99	3.97	2.45
964	6	-10	0	19.65	2.81	5.07	11.49	0.19	-11.22	-4.97	3.77	2.65
968	6	-10	5	19.59	3.72	9.30	11.49	0.60	-11.08	-10.56	3.92	2.50
998	6	-10	5	19.63	3.69	9.49	11.49	0.60	-11.02	-10.54	3.91	2.51
980	6	-10	10	19.75	4.49	11.81	11.49	1.37	-12.87	-14.64	4.28	2.14
999	6	-10	10	19.63	4.87	12.82	11.49	1.18	-12.32	-15.78	4.17	2.25
984	6	-10	15	19.69	8.39	20.87	11.49	0.68	-10.71	-26.60	4.06	2.36
867	6	0	-15	19.59	6.53	-11.30	11.49	-2.12	-11.70	9.27	3.48	3.00
863	6	0	-10	19.53	3.83	-4.33	11.49	-2.04	-14.07	3.83	3.78	2.70
859	6	0	-5	19.66	2.51	0.60	11.49	-1.10	-14.77	-0.63	3.90	2.58
843	6	0	0	19.69	2.31	4.84	11.49	-0.08	-14.36	-5.51	3.97	2.51
847	6	0	5	19.67	3.10	9.17	11.49	0.66	-13.77	-10.88	4.06	2.42
851	6	0	10	19.68	5.01	14.32	11.49	1.18	-13.75	-17.15	4.01	2.47
855	6	0	15	19.76	6.90	17.90	11.49	1.61	-14.59	-23.30	4.24	2.24
926	6	10	-15	19.70	7.53	-13.32	11.49	-1.51	-8.27	10.87	3.36	3.06
922	6	10	-10	19.70	3.74	-4.15	11.49	-2.00	-11.35	3.34	3.80	2.62
918	6	10	-5	19.54	2.63	-0.19	11.49	-1.35	-13.54	-0.50	4.04	2.38
887	6	10	0	19.63	2.35	3.56	11.49	-0.41	-14.59	-4.56	4.18	2.24
891	6	10	5	19.59	3.22	7.68	11.49	0.43	-15.14	-9.89	4.16	2.26
897	6	10	10	19.63	4.62	12.32	11.49	1.02	-15.08	-16.09	4.20	2.22
901	6	10	15	19.90	6.85	18.36	11.49	1.21	-15.26	-24.43	4.15	2.27
902	6	10	15	19.90	6.84	18.47	11.49	1.21	-15.22	-24.40	4.14	2.28
903	6	10	15	19.93	6.84	18.46	11.49	1.21	-15.20	-24.36	4.15	2.27
914	6	10	15	19.59	7.53	18.75	11.49	1.20	-15.08	-24.70	4.13	2.29
958	6	20	-15	19.65	2.65	-2.35	11.49	-4.27	-15.16	3.94	4.75	1.48
954	6	20	-10	19.70	4.06	-3.94	11.49	-1.91	-9.57	3.88	3.72	2.51
949	6	20	-5	19.57	2.70	0.20	11.49	-1.55	-11.78	-0.55	3.99	2.24
950	6	20	-5	19.53	2.66	0.03	11.49	-1.57	-11.86	-0.55	3.98	2.25
931	6	20	0	19.70	2.53	2.62	11.49	-0.72	-14.36	-3.57	4.27	1.96
935	6	20	5	19.73	2.53	5.13	11.49	0.27	-15.71	-7.18	4.36	1.87
940	6	20	10	19.76	3.58	8.07	11.49	1.13	-15.95	-11.38	4.43	1.80
945	6	20	15	19.76	5.39	11.52	11.49	1.69	-15.89	-16.68	4.43	1.80

* Indicates model was close to heave stop

TABLE 6.300.1 - STABILITY DATA IN BODY AXES AT PIVOT

30 deg Deadrise, L/R = 0.000, Cv = 0

RUN	Trim deg	Roll deg	Yaw deg	X lb	Y lb	Z lb	K lb-ft	M lb-ft	N lb-ft
1641	-2	-10	0	-0.48	2.02	-11.30	0.19	1.11	0.21
1645	-2	-10	5	-0.46	2.04	-11.30	0.19	1.06	0.20
1648	-2	-10	10	-0.45	2.00	-11.31	0.21	1.02	0.19
1651	-2	-10	15	-0.46	2.06	-11.29	0.08	0.98	0.20
1588	-2	0	0	-0.47	0.07	-11.48	-0.03	1.17	0.03
1593	-2	0	5	-0.44	0.02	-11.48	-0.01	1.03	0.01
1607	-2	0	10	-0.45	0.07	-11.48	0.00	1.08	0.03
1610	-2	0	15	-0.45	0.08	-11.48	-0.04	1.07	0.04
1614	-2	10	0	-0.46	-1.96	-11.31	-0.22	1.15	-0.17
1618	-2	10	5	-0.47	-1.91	-11.32	-0.22	1.02	-0.14
1621	-2	10	10	-0.44	-1.91	-11.32	-0.23	0.97	-0.14
1624	-2	10	15	-0.46	-1.90	-11.32	-0.25	0.94	-0.14
1628	-2	20	0	-0.47	-3.88	-10.81	-0.33	0.72	-0.23
1632	-2	20	5	-0.45	-3.81	-10.83	-0.36	0.62	-0.19
1635	-2	20	10	-0.46	-3.84	-10.82	-0.35	0.63	-0.20
1638	-2	20	15	-0.44	-3.84	-10.82	-0.33	0.58	-0.18
1571	0	-10	0	-0.05	2.04	-11.31	0.24	-3.25	-0.56
1575	0	-10	5	-0.05	2.07	-11.30	0.24	-3.27	-0.55
1579	0	-10	10	-0.04	2.07	-11.30	0.23	-3.29	-0.56
1583	0	-10	15	-0.04	2.07	-11.30	0.25	-3.38	-0.58
1511	0	0	0	-0.04	0.07	-11.49	0.02	-3.17	0.02
1527	0	0	5	-0.05	0.07	-11.49	0.02	-3.08	0.02
1532	0	0	10	-0.04	0.08	-11.49	0.02	-3.12	0.02
1535	0	0	15	-0.02	0.15	-11.49	0.03	-3.19	0.05
1539	0	10	0	0.04	-1.99	-11.32	-0.21	-3.50	0.28
1543	0	10	5	-0.05	-1.91	-11.33	-0.21	-3.33	0.61
1547	0	10	10	-0.04	-1.91	-11.33	-0.21	-3.35	0.61
1550	0	10	15	-0.03	-1.91	-11.33	-0.22	-3.39	0.63
1553	0	20	0	-0.05	-3.85	-10.83	-0.31	-3.25	1.21
1557	0	20	5	-0.04	-3.85	-10.83	-0.34	-3.37	1.24
1561	0	20	10	-0.03	-3.88	-10.81	-0.30	-3.28	1.22
1565	0	20	15	-0.04	-3.83	-10.83	-0.32	-3.33	1.24
1374	3	-10	0	0.56	2.06	-11.29	0.29	-8.36	-1.45
1379	3	-10	5	0.57	2.08	-11.29	0.29	-8.29	-1.42
1382	3	-10	10	0.57	2.09	-11.28	0.29	-8.26	-1.40
1386	3	-10	15	0.58	2.11	-11.28	0.30	-8.35	-1.42
1301	3	0	0	0.57	0.03	-11.48	0.05	-8.27	0.01
1307	3	0	0	0.56	0.07	-11.48	0.05	-8.41	0.02
1689	3	0	0	0.56	0.09	-11.48	0.06	-8.56	0.11
1309	3	0	5	0.57	0.07	-11.48	0.05	-8.41	0.04
1313	3	0	10	0.57	0.06	-11.48	0.05	-8.29	0.05
1318	3	0	15	0.57	0.07	-11.48	0.07	-8.46	0.03

* Indicates model was close to heave stop

TABLE 6.300.2 - STABILITY DATA IN BODY AXES AT PIVOT

30 deg Deadrise, L/R = 0.000, Cv = 0

RUN	Trim deg	Roll deg	Yaw deg	X lb	Y lb	Z lb	K lb-ft	M lb-ft	N lb-ft
1324	3	10	0	0.56	-1.92	-11.31	-0.15	-8.22	1.45
1328	3	10	5	0.56	-1.91	-11.32	-0.15	-8.23	1.47
1332	3	10	10	0.56	-1.90	-11.32	-0.16	-8.22	1.48
1336	3	10	15	0.57	-1.89	-11.32	-0.15	-8.13	1.47
1342	3	20	0	0.56	-3.85	-10.81	-0.30	-8.08	2.94
1359	3	20	5	0.56	-3.87	-10.80	-0.31	-8.31	3.03
1363	3	20	10	0.56	-3.82	-10.82	-0.29	-8.12	2.97
1367	3	20	15	0.57	-3.81	-10.82	-0.29	-8.16	2.99
1494	6	-10	0	1.15	2.04	-11.25	0.31	-11.48	-1.99
1498	6	-10	5	1.17	2.07	-11.24	0.31	-11.57	-1.98
1502	6	-10	10	1.16	2.10	-11.24	0.28	-11.54	-1.98
1506	6	-10	15	1.17	2.07	-11.24	0.29	-11.53	-1.97
1405	6	0	0	1.16	0.07	-11.43	0.08	-11.49	0.01
1438	6	0	0	1.18	0.02	-11.43	0.09	-11.96	0.01
1409	6	0	5	1.17	0.07	-11.43	0.08	-11.73	0.03
1440	6	0	10	1.16	0.09	-11.43	0.07	-11.42	0.05
1444	6	0	15	1.17	0.09	-11.43	0.09	-11.49	0.03
1455	6	0	15	1.16	0.05	-11.43	0.09	-11.44	0.03
1460	6	10	0	1.16	-1.93	-11.27	-0.13	-11.60	2.05
1464	6	10	5	1.16	-1.88	-11.28	-0.13	-11.45	2.04
1468	6	10	10	1.17	-1.88	-11.28	-0.13	-11.55	2.06
1472	6	10	15	1.17	-1.86	-11.28	-0.14	-11.79	2.11
1477	6	20	0	1.14	-3.81	-10.78	-0.29	-11.07	4.04
1481	6	20	5	1.16	-3.82	-10.78	-0.30	-11.12	4.04
1485	6	20	10	1.15	-3.82	-10.78	-0.29	-10.88	3.96
1489	6	20	15	1.16	-3.80	-10.78	-0.30	-11.13	4.05

* Indicates model was close to heave stop

TABLE 6.301.1 - STABILITY DATA IN BODY AXES AT PIVOT

30 deg Deadrise, L/R = 0.000, Cv = 1.5

RUN	Trim deg	Roll deg	Yaw deg	X lb	Y lb	Z lb	K lb-ft	M lb-ft	N lb-ft
1642	-2	-10	0	-1.94	2.27	-11.20	0.18	4.27	0.99
1646	-2	-10	5	-2.03	3.48	-10.99	0.15	4.13	3.05
1649	-2	-10	10	-2.25	5.57	-10.61	0.16	4.20	5.80
1652	-2	-10	15	-2.69	9.08	-9.98	0.05	4.55	9.75
1589	-2	0	0	-1.88	-0.05	-11.43	0.03	4.30	0.00
1594	-2	0	5	-2.00	1.09	-11.43	0.02	4.35	1.96
1608	-2	0	10	-2.35	3.75	-11.42	-0.03	5.11	4.59
1611 *	-2	0	15	-2.87	7.99	-11.40	-0.03	5.76	8.98
1615	-2	10	0	-1.97	-1.99	-11.25	-0.16	3.97	-1.14
1619	-2	10	5	-2.03	-0.92	-11.44	-0.26	4.36	0.73
1622	-2	10	10	-2.31	1.47	-11.85	-0.37	5.78	3.28
1625 *	-2	10	15	-3.14	6.53	-12.71	-0.34	8.86	7.41
1629	-2	20	0	-1.80	-4.07	-10.69	-0.21	3.48	-1.82
1633	-2	20	5	-1.97	-2.98	-11.08	-0.42	4.10	-0.35
1636	-2	20	10	-2.39	-0.91	-11.82	-0.67	5.60	1.90
1639 *	-2	20	15	-3.21	3.29	-13.31	-0.65	9.42	6.21
1572	0	-10	0	-1.21	2.34	-11.25	0.25	0.39	0.25
1576	0	-10	5	-1.31	3.13	-11.12	0.23	0.36	1.37
1580	0	-10	10	-1.47	4.96	-10.79	0.15	0.58	2.85
1584	0	-10	15	-1.74	8.25	-10.21	-0.04	1.33	5.44
1512	0	0	0	-1.21	-0.28	-11.49	0.12	0.62	0.01
1528	0	0	5	-1.26	0.95	-11.49	0.07	0.70	1.14
1533	0	0	10	-1.50	3.01	-11.49	0.01	1.49	2.36
1536	0	0	15	-1.85	7.22	-11.49	0.05	2.14	4.45
1540	0	10	0	-1.09	-2.16	-11.29	-0.11	0.13	-0.55
1544	0	10	5	-1.23	-1.06	-11.48	-0.21	0.72	0.90
1548	0	10	10	-1.48	0.98	-11.84	-0.37	1.86	2.18
1551	0	10	15	-1.86	4.61	-12.48	-0.39	3.98	3.56
1554	0	20	0	-1.17	-3.85	-10.83	-0.24	0.03	-0.29
1558	0	20	5	-1.18	-3.22	-11.06	-0.33	0.54	0.52
1562	0	20	10	-1.39	-1.37	-11.73	-0.59	1.84	1.64
1566	0	20	15	-1.92	2.06	-12.98	-0.72	4.75	3.15
1375	3	-10	0	-0.56	2.12	-11.34	0.39	-5.34	-0.71
1378	3	-10	5	-0.60	3.33	-11.13	0.35	-4.91	-0.64
1383	3	-10	10	-0.77	5.28	-10.79	0.32	-4.00	-0.77
1387	3	-10	15	-0.89	7.94	-10.33	0.28	-2.99	-0.72
1302	3	0	0	-0.53	0.22	-11.53	0.09	-5.46	0.01
1303	3	0	0	-0.57	0.28	-11.54	0.09	-5.48	0.03
1308	3	0	0	-0.54	0.05	-11.53	0.12	-5.52	0.02
1310	3	0	5	-0.61	1.23	-11.54	0.13	-5.27	0.23
1314	3	0	10	-0.73	3.00	-11.54	0.08	-4.57	0.11
1319	3	0	15	-0.99	6.55	-11.56	0.16	-3.10	-0.20

* Indicates model was close to heave stop

TABLE 6.301.2 - STABILITY DATA IN BODY AXES AT PIVOT

30 deg Deadrise, L/R = 0.000, Cv = 1.5

RUN	Trim deg	Roll deg	Yaw deg	X lb	Y lb	Z lb	K lb-ft	M lb-ft	N lb-ft
1325	3	10	0	-0.54	-1.78	-11.40	-0.15	-5.30	0.75
1329	3	10	5	-0.56	-1.12	-11.52	-0.14	-5.22	0.82
1333	3	10	10	-0.70	0.76	-11.85	-0.26	-4.63	0.75
1337	3	10	15	-0.90	3.96	-12.43	-0.27	-3.45	0.37
1343	3	20	0	-0.59	-3.80	-10.89	-0.27	-4.98	1.59
1360	3	20	5	-0.57	-3.11	-11.14	-0.29	-5.02	1.49
1364	3	20	10	-0.67	-1.78	-11.63	-0.38	-4.52	1.10
1368	3	20	15	-0.84	1.03	-12.67	-0.57	-2.97	0.19
1370	3	20	15	-0.89	1.06	-12.68	-0.54	-2.89	0.11
1495	6	-10	0	-0.44	2.17	-11.40	0.42	-9.26	-1.39
1499	6	-10	5	-0.44	3.37	-11.18	0.47	-8.67	-2.17
1503	6	-10	10	-0.54	5.34	-10.85	0.41	-7.68	-3.40
1507	6	-10	15	-0.68	8.75	-10.26	0.44	-6.32	-5.51
1406	6	0	0	-0.32	-0.08	-11.59	0.16	-9.60	0.05
1410	6	0	5	-0.47	1.28	-11.60	0.23	-9.47	-0.72
1441	6	0	10	-0.44	3.01	-11.60	0.21	-8.69	-1.83
1456	6	0	15	-0.60	5.96	-11.62	0.22	-7.76	-3.76
1461	6	10	0	-0.40	-1.92	-11.44	-0.11	-9.30	1.44
1465	6	10	5	-0.40	-0.78	-11.64	-0.03	-9.30	0.66
1469	6	10	10	-0.46	1.10	-11.97	-0.03	-9.18	-0.47
1473	6	10	15	-0.56	3.93	-12.48	-0.13	-8.51	-2.18
1478	6	20	0	-0.43	-3.93	-10.91	-0.28	-8.55	3.05
1482	6	20	5	-0.40	-2.44	-11.45	-0.31	-8.87	1.97
1486	6	20	10	-0.44	-0.94	-12.00	-0.23	-8.68	0.37

* Indicates model was close to heave stop

TABLE 6.303.1 - STABILITY DATA IN BODY AXES AT PIVOT

30 deg Deadrise, L/R = 0.000, Cv = 3

RUN	Trim deg	Roll deg	Yaw deg	X lb	Y lb	Z lb	K lb-ft	M lb-ft	N lb-ft
1643	-2	-10	0	-6.11	3.08	-10.91	0.38	-0.34	1.67
1647	-2	-10	5	-6.96	8.87	-9.86	0.28	-0.98	11.25
1650 *	-2	-10	10	-8.36	20.98	-7.68	0.12	-1.30	22.53
1590	-2	0	0	-5.92	-0.21	-11.29	0.07	-0.60	-0.58
1595	-2	0	5	-6.81	5.73	-11.26	-0.14	0.42	8.94
1609 *	-2	0	10	-8.31	19.70	-11.21	-0.10	2.75	20.36
1616	-2	10	0	-6.01	-3.51	-10.84	-0.32	-0.47	-3.11
1620	-2	10	5	-6.67	2.14	-11.82	-0.50	1.50	5.51
1623 *	-2	10	10	-8.25	16.10	-14.22	-0.48	5.23	16.50
1630	-2	20	0	-6.10	-5.37	-10.06	-0.48	0.39	-5.13
1634	-2	20	5	-7.67	-0.42	-11.80	-0.90	4.13	0.99
1637 *	-2	20	10	-9.08	11.28	-16.00	-0.96	10.56	10.43
1573	0	-10	0	-3.20	2.01	-11.31	0.26	1.34	1.17
1577	0	-10	5	-4.00	6.40	-10.54	0.08	1.61	3.68
1581	0	-10	10	-4.79	14.55	-9.10	-0.14	1.78	7.65
1585	0	-10	15	-4.10	17.88	-8.51	-0.02	3.49	8.01
1513	0	0	0	-3.17	-0.03	-11.49	0.05	2.49	0.02
1530	0	0	5	-3.85	4.14	-11.49	0.06	3.42	3.77
1534	0	0	10	-5.78	15.46	-11.49	-0.14	5.57	5.68
1541	0	10	0	-3.15	-2.07	-11.30	-0.13	1.01	-1.07
1545	0	10	5	-3.83	2.11	-12.04	-0.14	4.41	2.82
1549	0	10	10	-5.73	12.70	-13.91	-0.23	7.97	5.44
1555	0	20	0	-3.32	-3.85	-10.83	-0.25	0.07	-1.04
1559	0	20	5	-3.68	-0.09	-12.20	-0.36	3.34	0.98
1563	0	20	10	-5.65	9.81	-15.80	-0.56	8.67	7.78
1567	0	20	15	-6.72	20.53	-19.70	-0.39	17.22	5.89
1376	3	-10	0	-1.91	2.26	-11.39	0.39	-4.23	0.25
1380	3	-10	5	-2.13	5.43	-10.84	0.44	-2.82	-0.28
1668	3	-10	5	-2.20	5.24	-10.88	0.48	-2.95	-0.26
1384	3	-10	10	-2.86	13.09	-9.53	0.45	0.91	-2.26
1388	3	-10	15	-1.21	8.39	-10.27	0.70	-6.94	-5.74
1305	3	0	0	-1.77	0.37	-11.60	0.06	-4.80	0.06
1654	3	0	0	-1.79	-0.32	-11.60	0.48	-4.89	0.06
1311	3	0	5	-2.10	3.43	-11.62	0.22	-4.11	0.14
1655	3	0	5	-2.20	3.38	-11.62	0.47	-4.22	0.26
1316	3	0	10	-2.88	11.01	-11.66	0.22	-0.99	-1.42
1656	3	0	10	-3.04	11.00	-11.67	0.52	-0.78	-0.89
1320	3	0	15	-4.29	28.05	-11.73	0.39	6.69	-2.80
1657	3	0	15	-4.59	29.31	-11.75	0.39	6.96	-1.60

* Indicates model was close to heave stop

TABLE 6.303.2 - STABILITY DATA IN BODY AXES AT PIVOT

30 deg Deadrise, L/R = 0.000, Cv = 3

RUN	Trim deg	Roll deg	Yaw deg	X lb	Y lb	Z lb	K lb-ft	M lb-ft	N lb-ft
1326	3	10	0	-1.91	-2.26	-11.39	-0.17	-4.41	-0.04
1660	3	10	0	-1.97	-2.12	-11.42	-0.05	-4.38	-0.12
1330	3	10	5	-1.90	1.15	-11.99	-0.12	-4.51	-0.19
1659	3	10	5	-1.90	0.51	-11.87	-0.02	-4.53	-0.28
1334	3	10	10	-2.35	6.81	-13.01	-0.14	-3.09	-1.07
1661	3	10	10	-2.48	6.42	-12.95	0.21	-2.99	-0.94
1338	3	10	15	-3.33	19.00	-15.21	-0.12	2.33	-2.87
1662	3	10	15	-3.79	20.75	-15.54	-0.05	3.83	-2.71
1344	3	20	0	-1.88	-3.89	-10.93	-0.31	-3.69	0.24
1664	3	20	0	-1.97	-4.00	-10.90	-0.41	-3.77	0.02
1361	3	20	5	-1.84	-1.66	-11.74	-0.28	-3.84	-0.70
1665	3	20	5	-1.92	-1.54	-11.79	-0.14	-3.68	-0.81
1365	3	20	10	-1.92	2.16	-13.14	-0.35	-4.74	-2.31
1666	3	20	10	-1.98	2.39	-13.23	-0.23	-4.45	-2.31
1369	3	20	15	-2.31	9.25	-15.74	-0.58	-4.51	-5.25
1371	3	20	15	-2.30	9.21	-15.73	-0.59	-4.61	-5.37
1667	3	20	15	-2.41	9.45	-15.82	-0.33	-4.00	-5.08
1496	6	-10	0	-0.93	2.11	-11.46	0.42	-9.42	-1.26
1500	6	-10	5	-1.20	4.86	-11.00	0.57	-7.82	-3.27
1504	6	-10	10	-1.50	10.01	-10.13	0.57	-5.98	-8.31
1508	6	-10	15	-2.55	22.15	-8.10	0.75	-0.82	-15.65
1407	6	0	0	-0.87	-0.17	-11.64	0.15	-10.09	0.09
1411	6	0	5	-1.12	2.85	-11.67	0.35	-9.88	-2.34
1442	6	0	10	-1.33	6.87	-11.69	0.38	-8.58	-5.15
1457	6	0	15	-2.13	16.82	-11.78	0.36	-5.47	-12.16
1462	6	10	0	-0.98	-2.30	-11.43	-0.04	-9.69	1.24
1466	6	10	5	-0.91	0.80	-11.97	0.04	-10.84	-1.11
1470	6	10	10	-1.12	4.04	-12.56	0.17	-11.66	-4.37
1474	6	10	15	-1.43	9.71	-13.60	0.15	-11.63	-8.89
1479	6	20	0	-1.06	-3.82	-11.02	-0.32	-7.93	2.26
1483	6	20	5	-0.90	-1.54	-11.83	-0.21	-10.21	0.58
1487	6	20	10	-0.79	0.47	-12.55	-0.09	-12.44	-1.78
1491	6	20	15	-0.82	2.98	-13.47	-0.10	-14.30	-4.91

* Indicates model was close to heave stop

TABLE 6.304.1 - STABILITY DATA IN BODY AXES AT PIVOT

30 deg Deadrise, L/R = 0.000, Cv = 4

RUN	Trim deg	Roll deg	Yaw deg	X lb	Y lb	Z lb	K lb-ft	M lb-ft	N lb-ft
1644	* -2	-10	0	-11.53	3.75	-10.60	0.68	-3.66	2.63
1592	* -2	0	0	-11.14	-0.83	-11.11	0.11	-5.27	-1.43
1596	* -2	0	5	-12.08	11.83	-11.08	-0.14	-3.09	20.31
1617	* -2	10	0	-11.59	-4.67	-10.44	-0.53	-3.76	-5.56
1631	* -2	20	0	-11.29	-6.81	-9.34	-0.87	-3.39	-9.84
1574	0	-10	0	-5.69	2.02	-11.31	0.08	4.99	2.24
1578	0	-10	5	-8.15	10.10	-9.89	-0.06	4.55	8.28
1582	0	-10	10	-7.82	22.69	-7.67	-0.35	3.06	13.68
1586	0	-10	15	-2.02	7.87	-10.28	0.04	-0.81	1.12
1515	0	0	0	-5.43	-0.08	-11.49	0.03	6.34	-0.02
1531	0	0	5	-7.44	7.36	-11.49	0.01	8.48	6.76
1542	0	10	0	-5.63	-1.87	-11.34	-0.04	4.50	-1.99
1546	0	10	5	-6.93	5.26	-12.60	-0.01	10.86	5.14
1556	0	20	0	-6.38	-3.82	-10.84	-0.19	2.11	-1.99
1560	0	20	5	-6.88	3.18	-13.38	-0.16	10.59	2.18
1564	0	20	10	-8.75	16.65	-18.29	-0.36	19.67	7.98
1568	0	20	15	-11.39	37.36	-25.83	-0.17	30.72	11.51
1377	3	-10	0	-3.02	2.65	-11.38	0.35	-3.41	0.22
1381	3	-10	5	-3.23	6.82	-10.65	0.44	-1.45	-0.40
1385	3	-10	10	-4.06	16.85	-8.93	0.59	3.48	-4.48
1389	3	-10	15	-1.24	9.51	-10.07	0.57	-10.60	-9.77
1306	3	0	0	-2.89	0.11	-11.66	0.07	-4.54	0.05
1312	3	0	5	-3.21	5.28	-11.67	0.20	-3.57	-0.72
1317	3	0	10	-4.26	16.18	-11.73	0.22	0.79	-3.59
1322	3	0	10	-4.39	16.35	-11.74	0.29	1.02	-3.48
1321	3	0	15	-6.54	43.48	-11.85	0.74	14.49	-7.40

* Indicates model was close to heave stop

TABLE 6.304.2 - STABILITY DATA IN BODY AXES AT PIVOT

30 deg Deadrise, L/R = 0.000, Cv = 4

RUN	Trim deg	Roll deg	Yaw deg	X lb	Y lb	Z lb	K lb-ft	M lb-ft	N lb-ft
1327	3	10	0	-3.03	-2.38	-11.42	-0.25	-3.43	-0.08
1331	3	10	5	-2.99	2.45	-12.27	-0.06	-5.44	-1.28
1335	3	10	10	-3.56	11.01	-13.81	-0.08	-4.69	-4.14
1339	3	10	15	-5.59	32.66	-17.74	0.03	6.75	-5.32
1340	3	10	15	-5.61	32.60	-17.73	0.06	6.86	-5.20
1345	3	20	0	-2.86	-4.14	-10.90	-0.42	-2.17	-0.35
1362	3	20	5	-2.63	-1.17	-11.96	-0.33	-4.96	-0.96
1366	3	20	10	-2.88	3.89	-13.82	-0.42	-8.03	-4.10
1372	3	20	15	-3.31	12.59	-17.01	-0.90	-10.74	-10.19
1497	6	-10	0	-1.21	2.74	-11.38	0.46	-12.30	-2.85
1501	6	-10	5	-1.39	5.93	-10.83	0.61	-10.66	-6.39
1505	6	-10	10	-1.51	9.90	-10.15	0.60	-9.55	-10.79
1509	6	-10	15	-2.28	19.24	-8.58	0.74	-6.10	-21.10
1408	6	0	0	-1.08	-0.23	-11.67	0.21	-13.38	0.14
1412	6	0	5	-1.35	3.63	-11.69	0.33	-13.31	-4.65
1439	6	0	5	-1.29	3.50	-11.69	0.37	-13.66	-4.72
1443	6	0	10	-1.42	8.15	-11.70	0.41	-13.09	-9.93
1458	6	0	15	-1.81	14.93	-11.74	0.33	-12.43	-16.86
1463	6	10	0	-1.19	-3.04	-11.32	-0.06	-12.68	2.84
1467	6	10	5	-1.18	0.63	-11.97	-0.04	-13.95	-1.31
1471	6	10	10	-1.34	4.59	-12.68	0.04	-15.22	-6.49
1475	6	10	15	-1.48	10.25	-13.70	-0.12	-16.50	-13.31
1480	6	20	0	-1.19	-4.73	-10.71	-0.33	-10.87	4.67
1484	6	20	5	-0.85	-2.50	-11.48	-0.26	-13.19	2.25
1488	6	20	10	-0.90	-0.24	-12.31	-0.29	-15.20	-0.87
1492	6	20	15	-0.99	2.62	-13.36	-0.43	-16.95	-4.87

* Indicates model was close to heave stop

TABLE 6.310.1 - STABILITY DATA IN BODY AXES AT PIVOT

30 deg Deadrise, L/R = 0.117, Cv = 0

RUN	Trim deg	Roll deg	Yaw deg	X lb	Y lb	Z lb	K lb-ft	M lb-ft	N lb-ft
563	0	-10	-15	-0.04	2.05	-11.31	0.28	-3.07	-0.54
560	0	-10	-10	-0.05	2.07	-11.30	0.28	-3.04	-0.53
555	0	-10	-5	-0.06	2.07	-11.30	0.28	-3.05	-0.54
527	0	-10	0	-0.03	2.11	-11.29	0.27	-3.03	-0.50
548	0	-10	0	-0.01	2.01	-11.31	0.31	-3.05	-0.51
531	0	-10	5	0.00	2.10	-11.30	0.27	-3.04	-0.50
535	0	-10	10	0.00	2.15	-11.29	0.27	-3.00	-0.47
551	0	-10	15	-0.01	2.12	-11.29	0.27	-3.05	-0.50
463	0	0	-15	-0.06	0.07	-11.49	0.04	-2.93	0.02
460	0	0	-10	-0.07	0.07	-11.49	0.04	-2.92	0.01
456	0	0	-5	-0.06	0.07	-11.49	0.05	-2.95	0.00
77	0	0	0	-0.04	0.09	-11.49	0.04	-2.73	0.01
441	0	0	0	-0.10	0.00	-11.49	0.05	-2.89	0.02
476	0	0	0	-0.06	0.49	-11.49	0.05	-2.90	-0.77
446	0	0	5	-0.03	0.12	-11.49	0.05	-2.83	0.04
451	0	0	10	-0.01	0.14	-11.49	0.05	-2.81	0.04
454	0	0	15	-0.01	0.12	-11.49	0.04	-2.96	0.03
495	0	10	-15	-0.04	-1.92	-11.33	-0.18	-3.03	0.54
491	0	10	-10	-0.05	-1.93	-11.33	-0.19	-3.03	0.54
487	0	10	-5	-0.07	-1.93	-11.33	-0.20	-2.98	0.53
466	0	10	0	-0.04	-1.90	-11.33	-0.20	-3.05	0.56
478	0	10	5	-0.04	-1.88	-11.34	-0.18	-3.00	0.56
482	0	10	10	-0.02	-1.85	-11.34	-0.18	-2.96	0.58
485	0	10	15	-0.03	-1.89	-11.33	-0.20	-3.02	0.58
522	0	20	-15	-0.02	-3.85	-10.82	-0.34	-3.12	1.14
518	0	20	-10	-0.06	-3.85	-10.83	-0.34	-3.09	1.13
514	0	20	-5	-0.09	-3.85	-10.83	-0.33	-2.89	0.98
500	0	20	0	-0.03	-3.89	-10.81	-0.31	-2.97	1.09
504	0	20	5	-0.04	-3.80	-10.84	-0.32	-3.03	1.14
508	0	20	10	-0.03	-3.82	-10.84	-0.32	-2.99	1.12
512	0	20	15	-0.03	-3.81	-10.84	-0.34	-3.08	1.15
275	3	-10	-15	0.46	2.24	-11.26	0.30	-7.64	-1.30
271	3	-10	-10	0.52	2.17	-11.27	0.32	-7.83	-1.35
266	3	-10	-5	0.56	2.12	-11.28	0.32	-7.96	-1.38
245	3	-10	0	0.57	2.10	-11.28	0.31	-7.86	-1.37
250	3	-10	5	0.58	2.12	-11.28	0.32	-7.99	-1.39
256	3	-10	10	0.59	2.12	-11.28	0.33	-8.05	-1.38
260	3	-10	15	0.61	2.13	-11.28	0.32	-8.08	-1.41
128	3	0	-15	0.51	0.13	-11.48	0.09	-8.12	0.01
123	3	0	-10	0.53	0.11	-11.48	0.09	-8.29	0.02
119	3	0	-5	0.56	0.12	-11.48	0.09	-8.22	0.00
80	3	0	0	0.54	0.05	-11.48	0.08	-8.16	0.02
85	3	0	5	0.56	0.13	-11.48	0.09	-8.21	0.02
110	3	0	10	0.57	0.12	-11.48	0.10	-8.32	0.04
114	3	0	15	0.56	0.11	-11.48	0.09	-8.23	0.03

* Indicates model was close to heave stop

TABLE 6.310.2 - STABILITY DATA IN BODY AXES AT PIVOT

30 deg Deadrise, L/R = 0.117, Cv = 0

RUN	Trim deg	Roll deg	Yaw deg	X lb	Y lb	Z lb	K lb-ft	M lb-ft	N lb-ft
190	3	10	-15	0.42	-1.68	-11.36	-0.13	-7.57	1.41
183	3	10	-10	0.41	-1.52	-11.39	-0.12	-7.06	1.37
179	3	10	-5	0.46	-1.75	-11.35	-0.13	-7.70	1.38
137	3	10	0	0.50	-1.76	-11.35	-0.14	-7.66	1.38
169	3	10	0	0.57	-1.89	-11.32	-0.13	-8.00	1.40
145	3	10	5	0.56	-1.85	-11.33	-0.14	-7.96	1.42
149	3	10	10	0.58	-1.84	-11.33	-0.14	-8.01	1.44
239	3	20	-15	0.40	-3.61	-10.91	-0.25	-7.14	2.65
234	3	20	-10	0.48	-3.72	-10.86	-0.26	-7.48	2.74
230	3	20	-5	0.53	-3.77	-10.84	-0.27	-7.64	2.78
196	3	20	0	0.56	-3.79	-10.83	-0.27	-7.71	2.79
203	3	20	5	0.58	-3.78	-10.83	-0.27	-7.75	2.84
208	3	20	10	0.59	-3.79	-10.83	-0.27	-7.77	2.82
209	3	20	10	0.59	-3.81	-10.82	-0.27	-7.79	2.84
213	3	20	15	0.62	-3.79	-10.83	-0.27	-7.83	2.85
227	3	20	15	0.60	-3.79	-10.83	-0.28	-7.77	2.82
436	6	-10	-15	0.98	2.43	-11.20	0.31	-10.14	-1.64
432	6	-10	-10	1.07	2.26	-11.22	0.32	-10.73	-1.81
428	6	-10	-5	1.12	2.24	-11.22	0.33	-10.93	-1.85
403	6	-10	0	1.08	2.90	-11.10	0.25	-9.13	-1.25
407	6	-10	5	1.15	2.13	-11.23	0.33	-11.12	-1.87
411	6	-10	10	1.18	2.15	-11.23	0.33	-11.15	-1.88
424	6	-10	15	1.18	2.09	-11.24	0.34	-11.13	-1.90
323	6	0	-15	1.09	0.25	-11.44	0.11	-11.04	0.07
317	6	0	-10	1.10	0.28	-11.44	0.11	-11.04	0.07
311	6	0	-5	1.14	0.19	-11.43	0.12	-11.17	0.05
289	6	0	0	1.13	0.23	-11.43	0.12	-10.89	0.07
295	6	0	5	1.17	0.15	-11.43	0.13	-11.35	0.05
298	6	0	10	1.17	0.17	-11.43	0.12	-11.42	0.07
302	6	0	15	1.19	0.15	-11.43	0.13	-11.43	0.05
308	6	0	15	1.20	0.15	-11.43	0.12	-11.44	0.04
364	6	10	-15	1.07	-1.77	-11.31	-0.08	-10.87	1.96
359	6	10	-10	1.11	-1.82	-11.29	-0.08	-11.06	1.95
346	6	10	-5	1.14	-1.85	-11.28	-0.09	-11.25	2.00
355	6	10	-5	1.12	-1.83	-11.29	-0.09	-11.08	1.95
329	6	10	0	1.15	-1.89	-11.28	-0.09	-11.20	1.98
334	6	10	5	1.16	-1.85	-11.28	-0.10	-11.24	2.03
338	6	10	10	1.17	-1.84	-11.28	-0.10	-11.27	2.04
342	6	10	15	1.19	-1.83	-11.28	-0.10	-11.31	2.04
369	6	10	15	1.17	-1.83	-11.28	-0.09	-11.23	2.01
397	6	20	-15	1.12	-3.78	-10.79	-0.25	-10.70	3.87
393	6	20	-10	1.13	-3.80	-10.79	-0.25	-10.66	3.85
389	6	20	-5	1.16	-3.78	-10.79	-0.25	-10.69	3.87
372	6	20	0	1.14	-3.77	-10.80	-0.26	-10.66	3.87
376	6	20	5	1.21	-3.79	-10.78	-0.25	-10.75	3.91
381	6	20	10	1.18	-3.77	-10.79	-0.25	-10.69	3.91
385	6	20	15	1.19	-3.77	-10.79	-0.25	-10.72	3.92

* Indicates model was close to heave stop

TABLE 6.311.1 - STABILITY DATA IN BODY AXES AT PIVOT

30 deg Deadrise, L/R = 0.117, Cv = 1.5

RUN	Trim deg	Roll deg	Yaw deg	X lb	Y lb	Z lb	K lb-ft	M lb-ft	N lb-ft	
564	*	0	-10	-15	-2.11	-6.11	-12.74	0.49	4.04	-7.14
561		0	-10	-10	-1.61	-1.15	-11.87	0.47	1.92	-3.68
556		0	-10	-5	-1.32	1.02	-11.49	0.37	0.95	-1.88
528		0	-10	0	-1.16	2.12	-11.29	0.25	0.69	-0.43
532		0	-10	5	-1.26	3.00	-11.14	0.20	0.94	0.54
536		0	-10	10	-1.48	4.81	-10.82	0.14	1.40	1.72
550		0	-10	15	-1.84	7.99	-10.26	-0.03	2.38	3.99
464	*	0	0	-15	-2.01	-8.68	-11.49	0.10	1.73	-7.80
461		0	0	-10	-1.65	-3.56	-11.49	0.17	1.40	-4.11
457		0	0	-5	-1.43	-1.15	-11.49	0.07	0.91	-2.21
78		0	0	0	-1.19	0.05	-11.49	0.01	0.70	-0.78
443		0	0	0	-1.29	-0.01	-11.49	0.03	0.77	-0.80
448		0	0	5	-1.29	1.05	-11.49	0.02	1.23	0.23
452		0	0	10	-1.53	2.96	-11.49	-0.04	2.23	1.12
455	*	0	0	15	-2.21	7.68	-11.49	-0.06	4.30	2.99
496		0	10	-15	-1.82	-9.10	-10.06	0.15	0.71	-7.82
492		0	10	-10	-1.58	-5.44	-10.71	0.03	0.54	-4.42
488		0	10	-5	-1.40	-3.18	-11.11	-0.08	0.39	-2.36
467		0	10	0	-1.23	-1.93	-11.33	-0.16	0.51	-1.03
479		0	10	5	-1.23	-1.11	-11.47	-0.24	1.11	-0.06
483		0	10	10	-1.49	0.66	-11.78	-0.39	2.39	0.83
486	*	0	10	15	-2.05	4.57	-12.47	-0.47	5.11	1.78
523		0	20	-15	-2.12	-10.58	-8.38	0.18	0.48	-8.45
519		0	20	-10	-1.61	-6.74	-9.77	-0.09	-0.08	-4.36
515		0	20	-5	-1.45	-4.91	-10.44	-0.21	0.01	-2.49
501		0	20	0	-1.24	-4.02	-10.76	-0.33	0.05	-1.10
505		0	20	5	-1.22	-3.14	-11.08	-0.41	0.76	-0.39
509		0	20	10	-1.43	-1.68	-11.62	-0.61	2.24	0.26
513		0	20	15	-2.00	1.75	-12.87	-0.76	5.44	1.14
276	3	-10	-15	-0.96	-2.42	-12.16	0.42	-2.70	-1.00	
272	3	-10	-10	-0.76	-0.02	-11.73	0.43	-4.30	-1.41	
267	3	-10	-5	-0.66	1.55	-11.45	0.37	-4.87	-1.32	
246	3	-10	0	-0.57	2.49	-11.27	0.34	-4.87	-1.16	
249	3	-10	5	-0.65	3.51	-11.10	0.33	-4.35	-1.18	
251	3	-10	5	-0.64	3.50	-11.10	0.33	-4.35	-1.19	
253	3	-10	5	-0.63	3.52	-11.10	0.33	-4.32	-1.18	
257	3	-10	10	-0.84	5.68	-10.73	0.27	-3.20	-1.56	
261	3	-10	15	-1.01	8.79	-10.19	0.22	-2.38	-1.73	
129	3	0	-15	-0.99	-6.42	-11.56	0.03	-3.25	-1.30	
124	3	0	-10	-0.78	-2.57	-11.55	0.11	-4.58	-1.00	
120	3	0	-5	-0.66	-0.68	-11.54	0.10	-5.14	-0.82	
81	3	0	0	-0.63	0.32	-11.54	0.10	-5.24	-0.53	
87	3	0	5	-0.44	0.37	-11.53	0.11	-5.23	-0.54	
107	3	0	5	-0.66	1.44	-11.54	0.15	-4.84	-0.43	
111	3	0	10	-0.81	3.45	-11.55	0.10	-3.91	-0.82	
115	3	0	15	-1.07	7.24	-11.56	0.08	-2.14	-1.66	
135	3	0	15	-1.13	7.46	-11.57	0.09	-2.06	-1.59	

* Indicates model was close to heave stop

TABLE 6.311.2 - STABILITY DATA IN BODY AXES AT PIVOT

30 deg Deadrise, L/R = 0.117, Cv = 1.5

RUN	Trim deg	Roll deg	Yaw deg	X lb	Y lb	Z lb	K lb-ft	M lb-ft	N lb-ft
188	3	10	-15	-0.95	-5.77	-10.72	-0.10	-1.72	0.28
184	3	10	-10	-0.93	-4.61	-10.92	-0.12	-3.71	-0.08
180	3	10	-5	-0.82	-2.64	-11.26	-0.15	-4.43	0.04
138	3	10	0	-0.66	-1.63	-11.43	-0.16	-4.78	0.20
144	3	10	5	-0.62	-0.78	-11.58	-0.18	-4.78	0.12
146	3	10	5	-0.62	-0.73	-11.59	-0.17	-4.78	0.12
150	3	10	10	-0.71	0.95	-11.89	-0.23	-4.12	-0.23
170	3	10	15	-0.99	4.30	-12.49	-0.25	-2.64	-1.11
173	3	10	15	-0.99	4.34	-12.50	-0.25	-2.65	-1.08
174	3	10	15	-1.01	4.39	-12.51	-0.25	-2.64	-1.07
240	3	20	-15	-1.06	-6.89	-9.79	-0.11	-0.97	0.69
235	3	20	-10	-0.79	-5.83	-10.17	-0.22	-3.54	0.88
231	3	20	-5	-0.75	-4.59	-10.61	-0.28	-4.41	0.95
197	3	20	0	-0.61	-3.62	-10.96	-0.31	-4.80	1.02
204	3	20	5	-0.57	-2.77	-11.27	-0.36	-4.70	0.83
210	3	20	10	-0.69	-1.30	-11.81	-0.46	-4.22	0.21
214	3	20	15	-0.93	1.52	-12.85	-0.60	-2.50	-1.03
437	6	-10	-15	-0.53	-1.55	-12.06	0.29	-7.58	1.53
433	6	-10	-10	-0.46	0.04	-11.77	0.27	-8.54	-0.03
429	6	-10	-5	-0.40	1.39	-11.53	0.33	-8.67	-1.03
404	6	-10	0	-0.38	2.67	-11.30	0.37	-8.27	-1.80
408	6	-10	5	-0.46	3.96	-11.08	0.40	-7.87	-2.71
412	6	-10	10	-0.58	6.20	-10.70	0.36	-6.85	-4.18
425	6	-10	15	-0.69	9.78	-10.08	0.38	-5.30	-6.58
325	6	0	-15	-0.55	-4.80	-11.61	0.09	-7.39	2.78
318	6	0	-10	-0.45	-2.21	-11.60	0.06	-8.29	1.21
312	6	0	-5	-0.40	-0.66	-11.60	0.07	-8.91	0.28
290	6	0	0	-0.21	0.60	-11.58	0.14	-8.85	-0.43
294	6	0	5	-0.37	1.88	-11.59	0.19	-8.67	-1.32
299	6	0	10	-0.53	3.89	-11.61	0.19	-8.00	-2.68
303	6	0	15	-0.60	7.10	-11.62	0.14	-6.79	-4.79
309	6	0	15	-0.61	7.22	-11.62	0.13	-6.82	-4.85
365	6	10	-15	-0.57	-7.12	-10.54	-0.17	-6.27	4.23
360	6	10	-10	-0.46	-4.39	-11.01	-0.14	-7.76	2.58
347	6	10	-5	-0.45	-2.72	-11.30	-0.15	-8.57	1.62
330	6	10	0	-0.36	-1.54	-11.50	-0.10	-8.94	0.90
335	6	10	5	-0.35	-0.19	-11.73	-0.05	-8.93	0.03
339	6	10	10	-0.47	1.55	-12.06	-0.02	-8.62	-1.25
343	6	10	15	-0.59	4.42	-12.57	-0.08	-7.83	-3.28
398	6	20	-15	-0.54	-8.29	-9.34	-0.27	-4.97	5.20
394	6	20	-10	-0.49	-6.47	-10.00	-0.29	-6.91	4.20
390	6	20	-5	-0.42	-4.69	-10.64	-0.31	-7.81	3.13
373	6	20	0	-0.38	-3.39	-11.10	-0.32	-8.31	2.31
377	6	20	5	-0.36	-2.09	-11.57	-0.30	-8.49	1.17
382	6	20	10	-0.43	-0.34	-12.22	-0.23	-8.27	-0.51
386	6	20	15	-0.50	1.48	-12.89	-0.23	-8.04	-2.00

* Indicates model was close to heave stop

TABLE 6.313.1 - STABILITY DATA IN BODY AXES AT PIVOT

30 deg Deadrise, L/R = 0.117, Cv = 3

RUN	Trim deg	Roll deg	Yaw deg	X lb	Y lb	Z lb	K lb-ft	M lb-ft	N lb-ft
562 *	0	-10	-10	-6.44	-17.13	-14.69	0.78	2.87	-18.16
558	0	-10	-5	-4.01	-3.02	-12.20	0.39	4.68	-6.40
529	0	-10	0	-3.13	1.76	-11.36	0.26	1.98	-1.27
533	0	-10	5	-3.94	6.13	-10.59	0.13	2.94	1.06
537	0	-10	10	-5.44	16.81	-8.70	-0.10	3.54	3.40
552	0	-10	15	-3.20	14.85	-9.05	0.31	1.46	3.50
462 *	0	0	-10	-6.08	-19.53	-11.49	0.28	1.91	-17.93
458	0	0	-5	-4.14	-4.88	-11.49	0.15	2.14	-6.88
444	0	0	0	-3.31	-0.19	-11.49	0.07	2.65	-2.64
449	0	0	5	-3.82	4.13	-11.49	0.10	4.58	0.40
453 *	0	0	10	-7.11	19.12	-11.49	-0.24	5.64	2.95
497	0	10	-15	-2.31	-7.91	-10.27	-0.67	7.55	-5.62
493	0	10	-10	-4.78	-17.07	-8.66	0.37	0.77	-14.92
489	0	10	-5	-4.06	-6.99	-10.44	0.10	0.96	-6.60
468	0	10	0	-3.65	-2.05	-11.31	-0.12	1.07	-2.60
480	0	10	5	-3.79	2.27	-12.07	-0.09	4.52	-0.23
484	0	10	10	-5.51	12.96	-13.95	-0.24	6.82	1.42
524	0	20	-15	-4.06	-14.27	-7.03	0.09	11.24	-10.43
520	0	20	-10	-5.19	-13.43	-7.34	-0.05	8.89	-13.44
516	0	20	-5	-3.99	-8.77	-9.04	0.00	0.23	-6.74
502	0	20	0	-3.51	-4.42	-10.62	-0.28	0.53	-2.92
506	0	20	5	-3.68	-0.45	-12.06	-0.42	2.55	-0.94
510	0	20	10	-4.99	8.42	-15.29	-0.46	7.12	2.18
277	3	-10	-15	-2.57	-16.64	-14.75	0.39	1.74	-1.87
273	3	-10	-10	-2.05	-5.68	-12.79	0.47	-3.09	-1.41
269	3	-10	-5	-1.88	-0.06	-11.79	0.40	-3.98	-1.38
247	3	-10	0	-1.72	3.30	-11.19	0.44	-3.81	-1.43
254	3	-10	5	-2.11	6.79	-10.60	0.45	-2.49	-2.26
258	3	-10	10	-2.63	14.67	-9.24	0.43	1.50	-5.75
262	3	-10	15	-1.10	9.70	-10.03	0.66	-8.52	-7.26
130	3	0	-15	-2.97	-23.97	-11.66	-0.32	4.57	-2.20
125	3	0	-10	-2.28	-9.10	-11.63	0.08	-1.51	-1.84
121	3	0	-5	-2.07	-2.66	-11.61	0.08	-4.17	-1.83
82	3	0	0	-1.80	0.91	-11.60	0.18	-4.73	-1.38
88	3	0	5	-1.05	0.88	-11.56	0.16	-4.97	-1.39
101	3	0	5	-2.03	5.32	-11.61	0.29	-4.11	-3.10
105	3	0	5	-2.02	4.71	-11.61	0.28	-3.68	-1.91
112	3	0	10	-2.79	12.67	-11.65	0.29	-0.27	-4.53
116	3	0	15	-3.87	29.79	-11.71	0.46	7.98	-8.23
132	3	0	15	-4.26	31.62	-11.73	0.47	8.96	-7.55

* Indicates model was close to heave stop

TABLE 6.313.2 - STABILITY DATA IN BODY AXES AT PIVOT

30 deg Deadrise, L/R = 0.117, Cv = 3

RUN	Trim deg	Roll deg	Yaw deg	X lb	Y lb	Z lb	K lb-ft	M lb-ft	N lb-ft
191	3	10	-15	-1.05	-7.61	-10.40	-0.40	-4.77	3.39
185	3	10	-10	-2.28	-10.86	-9.89	-0.24	0.23	-0.24
181	3	10	-5	-2.01	-4.76	-10.95	-0.20	-2.87	-1.10
141	3	10	0	-1.84	-1.33	-11.55	-0.14	-4.48	-1.31
147	3	10	5	-1.69	2.03	-12.13	0.00	-4.62	-1.96
151	3	10	10	-2.15	7.82	-13.18	0.03	-3.01	-3.69
175	3	10	15	-3.34	21.76	-15.70	0.10	3.71	-8.00
241	3	20	-15	-1.15	-8.65	-9.16	-0.54	-1.97	4.48
236	3	20	-10	-1.79	-8.46	-9.26	-0.42	-0.29	1.30
232	3	20	-5	-2.02	-6.33	-10.05	-0.35	-2.52	0.29
200	3	20	0	-1.81	-3.00	-11.25	-0.37	-3.70	-0.98
206	3	20	5	-1.58	-0.35	-12.20	-0.27	-4.70	-1.98
211	3	20	10	-1.71	3.47	-13.60	-0.33	-5.74	-4.18
215	3	20	15	-1.89	10.09	-16.02	-0.57	-6.69	-8.15
216	3	20	15	-1.90	9.93	-15.96	-0.56	-6.33	-7.91
438	6	-10	-15	-0.79	-6.37	-12.94	0.23	-11.50	6.23
434	6	-10	-10	-0.80	-2.23	-12.21	0.22	-11.03	2.37
430	6	-10	-5	-0.74	0.74	-11.68	0.32	-10.02	-0.33
405	6	-10	0	-0.87	3.50	-11.21	0.47	-8.46	-2.36
409	6	-10	5	-1.34	7.33	-10.58	0.59	-7.00	-5.80
413	6	-10	10	-1.46	12.62	-9.66	0.53	-5.04	-10.76
426	6	-10	15	-1.65	21.85	-8.05	0.56	-0.69	-18.45
326	6	0	-15	-1.20	-11.46	-11.68	0.01	-7.07	7.79
319	6	0	-10	-1.02	-5.19	-11.66	-0.05	-9.09	3.61
315	6	0	-5	-1.00	-1.60	-11.66	0.07	-10.06	0.98
292	6	0	0	-0.88	1.47	-11.65	0.24	-10.05	-1.40
296	6	0	5	-1.04	4.62	-11.66	0.40	-9.43	-3.87
300	6	0	10	-1.37	9.51	-11.70	0.49	-8.27	-8.12
304	6	0	15	-1.63	18.21	-11.72	0.43	-5.39	-15.40
366	6	10	-15	-1.45	-15.28	-9.19	-0.31	-3.56	10.81
361	6	10	-10	-1.26	-7.34	-10.57	-0.23	-6.69	4.95
363	6	10	-10	-1.21	-7.44	-10.55	-0.25	-6.67	4.94
357	6	10	-5	-1.06	-3.50	-11.23	-0.21	-8.64	1.80
331	6	10	0	-0.83	-0.83	-11.67	-0.02	-10.19	0.04
336	6	10	5	-0.85	2.17	-12.20	0.12	-11.39	-2.55
340	6	10	10	-1.05	5.87	-12.88	0.21	-12.21	-6.16
344	6	10	15	-1.18	11.35	-13.86	0.16	-12.13	-11.03
400	6	20	-15	-1.07	-13.37	-7.55	-0.40	-4.10	11.89
395	6	20	-10	-1.10	-9.38	-9.00	-0.39	-5.13	7.24
391	6	20	-5	-1.14	-5.15	-10.55	-0.41	-7.23	3.16
374	6	20	0	-0.92	-2.67	-11.43	-0.28	-9.07	1.27
378	6	20	5	-0.69	-0.53	-12.18	-0.19	-11.25	-0.52
383	6	20	10	-0.71	1.92	-13.07	-0.15	-13.23	-3.07
387	6	20	15	-0.80	4.89	-14.16	-0.25	-15.06	-6.48

* Indicates model was close to heave stop

TABLE 6.314.1 - STABILITY DATA IN BODY AXES AT PIVOT

30 deg Deadrise, L/R = 0.117, Cv = 4

RUN	Trim deg	Roll deg	Yaw deg	X lb	Y lb	Z lb	K lb-ft	M lb-ft	N lb-ft
559	0	-10	-5	-6.76	-6.54	-12.82	0.37	10.90	-11.62
530	0	-10	0	-5.40	1.45	-11.41	0.16	5.89	-2.17
534	0	-10	5	-8.06	10.65	-9.79	0.01	7.40	0.36
554 *	0	-10	10	-10.28	30.79	-6.24	-0.15	2.35	11.37
553	0	-10	15	-1.81	8.77	-10.12	0.28	-2.39	0.68
459	0	0	-5	-7.55	-7.76	-11.49	0.39	6.12	-13.25
445	0	0	0	-5.35	-0.47	-11.49	0.09	5.93	-4.75
450	0	0	5	-6.88	7.62	-11.49	0.13	9.29	0.14
498	0	10	-15	-1.97	-8.16	-10.23	-0.11	1.50	-2.46
494	0	10	-10	-7.90	-27.07	-6.89	0.69	-0.32	-27.19
490	0	10	-5	-7.30	-10.23	-9.86	0.40	2.95	-14.30
469	0	10	0	-6.39	-1.84	-11.34	-0.03	2.67	-4.77
481	0	10	5	-6.83	6.02	-12.73	0.18	9.86	-0.34
525	0	20	-15	-3.80	-12.27	-7.76	-0.07	8.84	-4.99
521	0	20	-10	-7.79	-17.89	-5.72	-0.16	16.95	-21.06
517	0	20	-5	-6.91	-12.15	-7.80	0.27	1.46	-14.02
503	0	20	0	-6.32	-4.35	-10.65	-0.15	1.31	-5.89
507	0	20	5	-6.67	3.24	-13.41	-0.20	5.57	-1.08
278	3	-10	-15	-4.15	-29.92	-17.18	0.37	6.06	-3.07
274	3	-10	-10	-3.11	-9.91	-13.60	0.58	-3.77	-0.34
270	3	-10	-5	-2.83	-0.68	-11.95	0.41	-4.43	-1.24
248	3	-10	0	-2.85	4.24	-11.09	0.49	-2.32	-1.81
255	3	-10	5	-3.31	9.44	-10.19	0.51	-1.21	-3.80
259	3	-10	10	-3.75	19.64	-8.42	0.58	3.84	-9.19
265	3	-10	15	-1.01	10.51	-9.88	0.47	-11.82	-10.74
131	3	0	-15	-4.96	-41.63	-11.77	-0.76	12.34	-3.40
126	3	0	-10	-3.67	-14.51	-11.70	0.05	0.73	-2.66
122	3	0	-5	-2.95	-3.88	-11.66	0.09	-3.97	-1.71
83	3	0	0	-2.87	1.60	-11.66	0.25	-4.69	-2.12
106	3	0	5	-3.12	7.55	-11.67	0.42	-3.40	-3.74
113	3	0	10	-3.98	18.81	-11.71	0.44	0.77	-8.82
117	3	0	15	-6.45	52.46	-11.84	0.90	18.37	-14.82
133	3	0	15	-7.87	60.68	-11.92	0.89	23.04	-11.81

* Indicates model was close to heave stop

TABLE 6.314.2 - STABILITY DATA IN BODY AXES AT PIVOT

30 deg Deadrise, L/R = 0.117, Cv = 4

RUN	Trim deg	Roll deg	Yaw deg	X lb	Y lb	Z lb	K lb-ft	M lb-ft	N lb-ft
192	3	10	-15	-1.38	-10.07	-9.98	-0.28	-9.07	7.60
193	3	10	-15	-1.35	-10.34	-9.93	-0.26	-8.24	7.80
186	3	10	-10	-2.77	-12.60	-9.61	-0.24	0.91	1.62
182	3	10	-5	-2.62	-5.29	-10.89	-0.19	-2.23	-1.14
143	3	10	0	-2.68	-0.93	-11.66	-0.06	-4.86	-1.92
148	3	10	5	-2.75	4.37	-12.60	0.15	-6.52	-3.95
153	3	10	10	-3.11	13.23	-14.18	0.11	-5.63	-8.12
178	3	10	15	-5.14	35.99	-18.30	0.36	6.34	-14.11
243	3	20	-15	-1.18	-7.56	-9.56	-0.57	-8.01	7.14
238	3	20	-10	-1.91	-7.79	-9.52	-0.59	-2.85	3.62
233	3	20	-5	-2.90	-6.64	-9.99	-0.44	-1.12	-0.42
201	3	20	0	-2.40	-2.91	-11.32	-0.43	-3.65	-1.25
202	3	20	0	-2.38	-2.87	-11.33	-0.41	-3.67	-1.17
207	3	20	5	-2.27	0.89	-12.70	-0.30	-6.80	-2.71
212	3	20	10	-2.51	6.14	-14.62	-0.48	-9.45	-6.54
229	3	20	15	-2.75	15.04	-17.87	-0.97	-12.10	-13.30
439	6	-10	-15	-0.98	-7.23	-13.11	0.49	-15.46	9.14
435	6	-10	-10	-0.95	-2.52	-12.28	0.40	-14.35	3.44
431	6	-10	-5	-0.64	1.35	-11.56	0.43	-13.23	-0.99
406	6	-10	0	-1.16	4.83	-11.00	0.53	-11.73	-4.71
410	6	-10	5	-1.36	8.41	-10.39	0.66	-9.83	-8.22
414	6	-10	10	-1.41	12.63	-9.66	0.62	-9.75	-14.15
427	6	-10	15	-1.35	18.03	-8.70	0.59	-8.11	-20.72
327	6	0	-15	-1.32	-12.76	-11.69	0.00	-12.62	13.24
322	6	0	-10	-1.19	-6.22	-11.68	-0.03	-13.35	7.05
316	6	0	-5	-1.25	-1.86	-11.69	0.11	-13.89	2.18
293	6	0	0	-1.18	2.31	-11.68	0.29	-13.70	-2.52
297	6	0	5	-1.31	6.48	-11.69	0.44	-13.40	-7.26
301	6	0	10	-1.32	11.23	-11.69	0.45	-13.32	-12.85
306	6	0	15	-1.31	17.24	-11.69	0.31	-13.23	-19.56
368	6	10	-15	-1.81	-16.38	-9.04	-0.37	-6.83	15.81
362	6	10	-10	-1.15	-7.79	-10.48	-0.32	-9.91	7.93
358	6	10	-5	-1.08	-4.10	-11.12	-0.20	-11.72	4.39
333	6	10	0	-0.89	-0.92	-11.66	-0.07	-13.57	0.86
337	6	10	5	-1.11	3.03	-12.38	0.02	-14.92	-3.61
341	6	10	10	-1.34	7.80	-13.25	0.04	-16.37	-9.36
345	6	10	15	-1.38	14.01	-14.35	-0.11	-17.81	-16.83
370	6	10	15	-1.40	14.06	-14.36	-0.09	-17.81	-17.01
401	6	20	-15	-1.09	-12.78	-7.77	-0.50	-6.41	14.96
396	6	20	-10	-1.40	-9.58	-8.97	-0.50	-7.37	9.96
392	6	20	-5	-1.12	-5.44	-10.44	-0.46	-9.28	4.99
375	6	20	0	-0.99	-3.26	-11.22	-0.33	-12.19	3.29
379	6	20	5	-0.78	-0.88	-12.06	-0.32	-14.58	0.80
380	6	20	5	-0.76	-0.87	-12.06	-0.32	-14.63	0.76
384	6	20	10	-0.81	1.74	-13.02	-0.39	-16.40	-2.52
388	6	20	15	-1.00	5.44	-14.39	-0.58	-18.72	-7.22

* Indicates model was close to heave stop

TABLE 6.320.1 - STABILITY DATA IN BODY AXES AT PIVOT

30 deg Deadrise, L/R = 0.234, Cv = 0

RUN	Trim deg	Roll deg	Yaw deg	X lb	Y lb	Z lb	K lb-ft	M lb-ft	N lb-ft
1126	0	-10	-15	0.04	1.83	-11.34	0.26	-3.30	-0.55
1122	0	-10	-10	0.02	1.71	-11.37	0.28	-3.22	-0.54
1117	0	-10	-5	0.03	1.69	-11.37	0.29	-3.24	-0.53
1101	0	-10	0	-0.02	1.72	-11.36	0.28	-3.19	-0.51
1105	0	-10	5	-0.01	1.75	-11.36	0.28	-3.18	-0.51
1110	0	-10	10	-0.02	1.73	-11.36	0.29	-3.12	-0.52
1113	0	-10	15	-0.05	1.90	-11.33	0.24	-3.00	-0.52
1024	0	0	-15	0.06	-0.15	-11.49	0.04	-3.16	0.03
1020	0	0	-10	0.04	-0.27	-11.49	0.08	-3.13	0.03
1016	0	0	-5	0.01	-0.25	-11.49	0.08	-3.09	0.05
1003	0	0	0	-0.01	-0.04	-11.49	0.04	-2.93	0.04
1085	0	0	0	0.03	-0.32	-11.49	0.07	-3.18	0.00
1007	0	0	5	-0.01	-0.20	-11.49	0.08	-2.95	0.04
1011	0	0	10	-0.01	-0.31	-11.49	0.08	-2.97	0.03
1014	0	0	15	-0.03	-0.15	-11.49	0.02	-2.95	0.04
1058	0	10	-15	0.03	-2.09	-11.30	-0.20	-3.32	0.60
1054	0	10	-10	0.03	-2.13	-11.29	-0.22	-3.28	0.61
1050	0	10	-5	0.02	-2.10	-11.30	-0.21	-3.26	0.62
1035	0	10	0	-0.01	-2.09	-11.30	-0.17	-3.11	0.57
1039	0	10	5	-0.01	-2.22	-11.28	-0.15	-3.21	0.59
1043	0	10	10	-0.02	-2.23	-11.27	-0.14	-3.20	0.58
1048	0	10	15	-0.04	-2.13	-11.29	-0.20	-3.19	0.58
1096	0	20	-15	0.04	-4.26	-10.68	-0.27	-3.39	1.28
1092	0	20	-10	0.03	-4.21	-10.69	-0.27	-3.37	1.25
1087	0	20	-5	-0.01	-4.16	-10.71	-0.27	-3.29	1.24
1063	0	20	0	-0.02	-4.05	-10.75	-0.31	-3.22	1.20
1067	0	20	5	-0.02	-4.02	-10.76	-0.33	-3.24	1.21
1072	0	20	10	-0.04	-4.16	-10.71	-0.28	-3.26	1.20
1076	0	20	15	-0.04	-4.17	-10.71	-0.28	-3.24	1.20
832	3	-10	-15	0.65	1.89	-11.31	0.31	-8.24	-1.40
828	3	-10	-10	0.66	1.80	-11.33	0.31	-8.31	-1.39
824	3	-10	-5	0.65	1.80	-11.33	0.36	-8.28	-1.41
800	3	-10	0	0.64	1.78	-11.34	0.36	-8.24	-1.38
816	3	-10	10	0.62	1.78	-11.34	0.36	-8.21	-1.42
820	3	-10	15	0.60	1.75	-11.34	0.36	-8.27	-1.43
692	3	0	-15	0.66	-0.06	-11.47	0.08	-8.39	0.05
688	3	0	-10	0.66	-0.20	-11.47	0.07	-8.43	0.06
699	3	0	-10	0.65	-0.05	-11.47	0.09	-8.40	0.06
684	3	0	-5	0.66	-0.05	-11.47	0.08	-8.35	0.02
704	3	0	-5	0.65	-0.16	-11.47	0.07	-8.49	0.07
657	3	0	0	0.64	-0.06	-11.47	0.08	-8.30	0.04
708	3	0	0	0.62	-0.09	-11.47	0.07	-8.32	0.04
661	3	0	5	0.63	-0.07	-11.47	0.07	-8.36	0.06
712	3	0	5	0.63	-0.12	-11.47	0.07	-8.32	0.04
675	3	0	10	0.61	-0.09	-11.47	0.07	-8.36	0.01
718	3	0	10	0.63	-0.03	-11.47	0.08	-8.40	0.05
679	3	0	15	0.60	-0.09	-11.47	0.07	-8.34	0.01
722	3	0	15	0.62	-0.16	-11.47	0.06	-8.33	0.04

* Indicates model was close to heave stop

TABLE 6.320.2 - STABILITY DATA IN BODY AXES AT PIVOT

30 deg Deadrise, L/R = 0.234, Cv = 0

RUN	Trim deg	Roll deg	Yaw deg	X lb	Y lb	Z lb	K lb-ft	M lb-ft	N lb-ft
764	3	10	-15	0.67	-2.14	-11.27	-0.15	-8.35	1.52
760	3	10	-10	0.65	-2.06	-11.29	-0.15	-8.25	1.49
756	3	10	-5	0.65	-2.22	-11.26	-0.11	-8.33	1.50
726	3	10	0	0.63	-2.10	-11.28	-0.15	-8.29	1.48
752	3	10	5	0.62	-2.11	-11.28	-0.16	-8.21	1.48
730	3	10	10	0.63	-2.11	-11.28	-0.15	-8.26	1.48
743	3	10	10	0.57	-2.11	-11.28	-0.15	-8.12	1.44
748	3	10	15	0.59	-2.25	-11.26	-0.11	-8.20	1.43
795	3	20	-15	0.66	-4.08	-10.72	-0.28	-8.04	2.94
791	3	20	-10	0.65	-4.03	-10.74	-0.29	-8.00	2.94
787	3	20	-5	0.66	-4.01	-10.75	-0.29	-7.93	2.92
771	3	20	0	0.62	-4.23	-10.67	-0.27	-7.98	2.92
775	3	20	5	0.61	-4.15	-10.70	-0.25	-7.99	2.91
779	3	20	10	0.61	-4.15	-10.70	-0.25	-7.97	2.92
783	3	20	15	0.59	-4.16	-10.70	-0.29	-7.96	2.90
994	6	-10	-15	1.28	1.89	-11.26	0.30	-11.19	-1.90
989	6	-10	-10	1.26	1.87	-11.27	0.30	-11.23	-1.88
985	6	-10	-5	1.26	1.86	-11.27	0.30	-11.22	-1.91
962	6	-10	0	1.25	1.91	-11.26	0.30	-11.22	-1.89
965	6	-10	5	1.23	1.91	-11.26	0.30	-11.22	-1.85
977	6	-10	10	1.21	1.92	-11.26	0.30	-11.19	-1.89
981	6	-10	15	1.22	1.91	-11.27	0.30	-11.08	-1.87
864	6	0	-15	1.26	-0.09	-11.42	0.09	-11.51	0.06
860	6	0	-10	1.28	-0.10	-11.42	0.09	-11.54	0.08
856	6	0	-5	1.25	-0.10	-11.42	0.09	-11.54	0.05
839	6	0	0	1.23	-0.04	-11.42	0.09	-11.46	0.07
844	6	0	5	1.23	-0.05	-11.42	0.09	-11.50	0.08
848	6	0	10	1.22	-0.10	-11.42	0.09	-11.49	0.07
852	6	0	15	1.20	-0.09	-11.43	0.10	-11.44	0.04
923	6	10	-15	1.27	-2.08	-11.23	-0.11	-11.28	2.02
919	6	10	-10	1.25	-2.08	-11.23	-0.11	-11.29	2.02
915	6	10	-5	1.24	-2.06	-11.24	-0.11	-11.27	2.03
869	6	10	0	1.23	-2.10	-11.23	-0.12	-11.25	2.05
881	6	10	0	1.21	-2.02	-11.25	-0.12	-11.27	2.05
912	6	10	0	1.22	-2.10	-11.23	-0.12	-11.32	2.04
888	6	10	5	1.23	-2.02	-11.24	-0.12	-11.22	2.05
892	6	10	10	1.22	-2.05	-11.24	-0.13	-11.21	2.02
898	6	10	15	1.21	-2.07	-11.24	-0.12	-11.30	2.03
913	6	10	15	1.20	-2.01	-11.25	-0.12	-11.18	2.00
955	6	20	-15	1.28	-4.02	-10.69	-0.27	-10.72	3.91
951	6	20	-10	1.26	-4.03	-10.69	-0.27	-10.80	3.96
946	6	20	-5	1.25	-4.00	-10.70	-0.28	-10.81	3.97
928	6	20	0	1.24	-3.98	-10.71	-0.28	-10.81	3.98
932	6	20	5	1.23	-3.95	-10.72	-0.28	-10.70	3.95
936	6	20	10	1.21	-3.98	-10.71	-0.28	-10.71	3.93
943	6	20	15	1.21	-4.01	-10.70	-0.28	-10.78	3.94

* Indicates model was close to heave stop

TABLE 6.321.1 - STABILITY DATA IN BODY AXES AT PIVOT

30 deg Deadrise, L/R = 0.234, Cv = 1.5

RUN	Trim deg	Roll deg	Yaw deg	X lb	Y lb	Z lb	K lb-ft	M lb-ft	N lb-ft
1127	0	-10	-15	-1.76	-5.50	-12.64	0.50	2.35	-7.62
1129 *	0	-10	-15	-1.87	-6.09	-12.74	0.51	2.58	-8.61
1123	0	-10	-10	-1.43	-1.42	-11.92	0.46	1.14	-4.63
1118	0	-10	-5	-1.18	0.70	-11.54	0.35	0.41	-2.60
1102	0	-10	0	-1.13	1.87	-11.34	0.24	0.57	-1.05
1106	0	-10	5	-1.18	2.79	-11.18	0.21	1.15	-0.22
1111	0	-10	10	-1.49	4.63	-10.85	0.15	2.09	0.49
1114	0	-10	15	-1.74	6.88	-10.45	0.02	2.23	2.32
1025	0	0	-15	-1.65	-8.56	-11.49	0.05	0.83	-8.51
1021	0	0	-10	-1.41	-3.90	-11.49	0.17	0.84	-4.88
1017	0	0	-5	-1.28	-1.41	-11.49	0.11	0.41	-2.90
1004	0	0	0	-1.16	-0.06	-11.49	0.04	0.68	-1.49
1008	0	0	5	-1.25	0.92	-11.49	0.02	1.43	-0.63
1012	0	0	10	-1.53	2.74	-11.49	-0.04	2.81	-0.10
1015 *	0	0	15	-2.19	7.43	-11.49	-0.05	5.42	0.76
1059	0	10	-15	-2.13	-8.29	-10.21	0.19	1.57	-7.48
1055	0	10	-10	-1.43	-5.68	-10.67	0.05	0.18	-4.94
1051	0	10	-5	-1.34	-3.50	-11.05	-0.05	0.10	-3.06
1036	0	10	0	-1.22	-2.19	-11.28	-0.13	0.43	-1.70
1040	0	10	5	-1.26	-1.23	-11.45	-0.26	1.13	-0.95
1044	0	10	10	-1.50	0.40	-11.74	-0.37	2.67	-0.53
1045	0	10	10	-1.54	0.61	-11.77	-0.41	2.76	-0.52
1049	0	10	15	-2.13	4.46	-12.45	-0.45	5.77	-0.24
1097	0	20	-15	-2.25	-9.74	-8.68	0.11	-0.05	-7.23
1093	0	20	-10	-1.58	-6.64	-9.81	-0.08	-0.72	-4.03
1088	0	20	-5	-1.32	-5.19	-10.34	-0.17	-0.53	-2.63
1064	0	20	0	-1.24	-4.13	-10.72	-0.28	-0.08	-1.66
1068	0	20	5	-1.28	-3.26	-11.04	-0.41	0.79	-1.14
1071	0	20	10	-1.49	-1.87	-11.55	-0.62	2.38	-0.96
1073	0	20	10	-1.49	-1.72	-11.60	-0.63	2.43	-1.00
1077	0	20	15	-1.98	1.39	-12.74	-0.80	5.28	-0.75
833	3	-10	-15	-0.71	-2.93	-12.24	0.51	-3.94	-2.58
829	3	-10	-10	-0.64	-0.15	-11.74	0.47	-4.97	-2.19
825	3	-10	-5	-0.58	1.62	-11.43	0.40	-5.18	-1.83
801	3	-10	0	-0.58	2.61	-11.25	0.36	-4.87	-1.71
813	3	-10	5	-0.63	3.86	-11.04	0.32	-4.01	-1.92
817	3	-10	10	-0.83	6.22	-10.63	0.24	-2.42	-2.68
821	3	-10	15	-1.18	10.33	-9.92	0.27	-0.47	-3.80
698	3	0	-15	-0.84	-5.99	-11.55	0.10	-3.98	-2.49
689	3	0	-10	-0.54	-2.31	-11.53	0.16	-4.81	-1.40
700	3	0	-10	-0.68	-2.41	-11.54	0.19	-4.92	-1.70
685	3	0	-5	-0.57	-0.60	-11.54	0.17	-5.28	-1.30
705	3	0	-5	-0.63	-0.76	-11.54	0.15	-5.35	-1.32
658	3	0	0	-0.57	0.48	-11.54	0.16	-5.21	-1.04
711	3	0	0	-0.60	0.51	-11.54	0.15	-5.17	-1.07
662	3	0	5	-0.60	1.58	-11.54	0.16	-4.71	-1.18
713	3	0	5	-0.59	1.64	-11.54	0.16	-4.68	-1.17
676	3	0	10	-0.79	3.76	-11.55	0.11	-3.58	-1.94
719	3	0	10	-0.81	3.92	-11.55	0.12	-3.51	-1.88

* Indicates model was close to heave stop

TABLE 6.321.2 - STABILITY DATA IN BODY AXES AT PIVOT

30 deg Deadrise, L/R = 0.234, Cv = 1.5

RUN	Trim deg	Roll deg	Yaw deg	X lb	Y lb	Z lb	K lb-ft	M lb-ft	N lb-ft
680	3	0	15	-1.12	8.01	-11.56	0.07	-1.21	-3.38
723	3	0	15	-1.15	8.06	-11.57	0.05	-1.16	-3.31
765	3	10	-15	-0.78	-6.91	-10.51	-0.11	-3.05	-1.09
761	3	10	-10	-0.71	-4.56	-10.92	-0.11	-4.68	-0.65
757	3	10	-5	-0.63	-2.84	-11.22	-0.13	-5.15	-0.43
727	3	10	0	-0.60	-1.64	-11.43	-0.14	-5.33	-0.26
753	3	10	5	-0.64	-0.70	-11.59	-0.16	-4.96	-0.53
731	3	10	10	-0.72	1.23	-11.94	-0.20	-4.05	-1.29
749	3	10	15	-1.01	4.82	-12.59	-0.22	-2.10	-2.64
796	3	20	-15	-0.86	-7.37	-9.61	-0.17	-2.32	-0.05
792	3	20	-10	-0.70	-5.94	-10.12	-0.27	-4.21	0.52
788	3	20	-5	-0.61	-4.69	-10.57	-0.29	-4.99	0.69
772	3	20	0	-0.61	-3.64	-10.95	-0.32	-5.08	0.59
776	3	20	5	-0.65	-2.62	-11.33	-0.37	-4.80	0.15
780	3	20	10	-0.71	-0.98	-11.93	-0.45	-4.24	-0.75
784	3	20	15	-0.95	1.61	-12.88	-0.54	-2.64	-2.37
995	6	-10	-15	-0.33	-1.63	-12.05	0.32	-8.65	0.25
990	6	-10	-10	-0.31	0.32	-11.71	0.28	-8.96	-0.79
991	6	-10	-10	-0.35	0.31	-11.71	0.28	-8.95	-0.83
986	6	-10	-5	-0.30	1.70	-11.46	0.33	-8.75	-1.60
960	6	-10	0	-0.28	2.95	-11.24	0.37	-8.37	-2.43
961	6	-10	0	-0.26	2.89	-11.25	0.36	-8.39	-2.44
966	6	-10	5	-0.33	4.44	-10.98	0.37	-7.56	-3.53
978	6	-10	10	-0.47	6.97	-10.55	0.35	-6.30	-5.52
982	6	-10	15	-0.72	11.13	-9.85	0.37	-4.22	-8.14
865	6	0	-15	-0.37	-4.22	-11.59	0.10	-8.28	1.64
861	6	0	-10	-0.33	-1.92	-11.59	0.07	-8.97	0.47
857	6	0	-5	-0.34	-0.57	-11.59	0.10	-9.23	-0.28
840	6	0	0	-0.30	0.80	-11.59	0.17	-9.11	-1.05
845	6	0	5	-0.36	2.25	-11.59	0.22	-8.65	-2.12
849	6	0	10	-0.48	4.53	-11.60	0.17	-7.74	-3.86
853	6	0	15	-0.68	8.55	-11.63	0.15	-6.07	-6.60
924	6	10	-15	-0.37	-6.34	-10.65	-0.16	-7.31	3.19
920	6	10	-10	-0.36	-4.03	-11.06	-0.14	-8.29	1.97
916	6	10	-5	-0.28	-2.40	-11.34	-0.14	-8.77	1.14
870	6	10	0	-0.33	-1.27	-11.54	-0.08	-8.96	0.32
871	6	10	0	-0.34	-1.30	-11.54	-0.10	-9.14	0.31
889	6	10	5	-0.32	0.13	-11.79	-0.03	-8.87	-0.66
893	6	10	10	-0.32	1.88	-12.10	0.00	-8.29	-2.15
894	6	10	10	-0.39	1.99	-12.12	0.00	-8.38	-2.22
899	6	10	15	-0.54	4.95	-12.66	-0.05	-7.48	-4.60
956	6	20	-15	-0.39	-7.45	-9.63	-0.31	-5.92	4.42
952	6	20	-10	-0.37	-5.81	-10.22	-0.32	-7.45	3.62
947	6	20	-5	-0.29	-4.29	-10.76	-0.33	-8.16	2.66
929	6	20	0	-0.32	-3.12	-11.20	-0.31	-8.58	1.68
933	6	20	5	-0.37	-1.67	-11.73	-0.29	-8.73	0.35
937	6	20	10	-0.34	-0.10	-12.30	-0.20	-8.41	-1.19
941	6	20	15	-0.48	2.01	-13.08	-0.20	-8.16	-3.03
942	6	20	15	-0.45	1.85	-13.02	-0.21	-8.20	-3.00

* Indicates model was close to heave stop

TABLE 6.323.1 - STABILITY DATA IN BODY AXES AT PIVOT

30 deg Deadrise, L/R = 0.234, Cv = 3

RUN	Trim deg	Roll deg	Yaw deg	X lb	Y lb	Z lb	K lb-ft	M lb-ft	N lb-ft
1128 *	0	-10	-15	-6.43	-29.66	-16.90	0.43	7.32	-27.76
1124	0	-10	-10	-5.21	-12.88	-13.94	0.84	6.20	-17.40
1120	0	-10	-5	-3.46	-3.34	-12.26	0.50	3.20	-8.29
1103	0	-10	0	-3.10	1.49	-11.40	0.30	1.90	-3.10
1108	0	-10	5	-3.52	6.06	-10.60	0.16	3.69	-1.63
1112	0	-10	10	-6.21	20.35	-8.08	-0.12	8.29	-2.63
1115	0	-10	15	-2.00	8.71	-10.13	0.78	-3.15	0.15
1026	0	0	-15	-3.03	-11.94	-11.49	-0.68	14.97	-11.94
1022	0	0	-10	-4.93	-16.15	-11.49	0.64	1.28	-18.21
1018	0	0	-5	-3.60	-5.55	-11.49	0.31	1.89	-9.75
1005	0	0	0	-3.27	-0.52	-11.49	0.12	2.55	-5.01
1009	0	0	5	-3.52	4.12	-11.49	0.13	5.21	-2.72
1013 *	0	0	10	-6.51	19.20	-11.49	-0.19	8.76	-4.10
1060	0	10	-15	-2.32	-7.70	-10.31	-0.61	9.38	-6.96
1056	0	10	-10	-4.29	-15.34	-8.96	0.38	2.49	-15.48
1052	0	10	-5	-4.05	-7.46	-10.35	0.12	0.71	-8.41
1037	0	10	0	-3.69	-2.53	-11.22	-0.11	1.10	-4.71
1041	0	10	5	-3.73	2.32	-12.08	-0.05	4.06	-3.70
1046	0	10	10	-5.90	14.96	-14.31	-0.16	7.70	-4.38
1098	0	20	-15	-4.90	-16.36	-6.27	-0.08	13.18	-16.25
1094	0	20	-10	-4.75	-12.53	-7.67	-0.12	9.83	-13.45
1089	0	20	-5	-3.65	-8.80	-9.02	-0.00	0.06	-7.71
1065	0	20	0	-3.58	-4.71	-10.51	-0.28	0.45	-4.67
1069	0	20	5	-3.80	-0.32	-12.11	-0.43	2.21	-3.48
1074	0	20	10	-5.02	9.28	-15.60	-0.33	6.19	-2.88
1078 *	0	20	15	-6.59	25.42	-21.48	-0.16	12.33	-6.02
834	3	-10	-15	-2.62	-16.99	-14.82	0.61	1.79	-7.08
830	3	-10	-10	-2.28	-5.60	-12.79	0.66	-2.74	-4.19
826	3	-10	-5	-2.06	0.36	-11.73	0.53	-3.68	-3.05
802	3	-10	0	-2.15	4.31	-11.04	0.52	-3.28	-3.08
814	3	-10	5	-2.23	8.44	-10.31	0.46	-1.89	-4.83
818	3	-10	10	-2.80	17.51	-8.74	0.42	3.03	-9.50
822	3	-10	15	-1.26	11.19	-9.78	0.74	-9.86	-9.72
697	3	0	-15	-2.88	-21.28	-11.66	-0.14	2.80	-5.98
690	3	0	-10	-2.62	-9.35	-11.64	0.22	-1.58	-5.54
701	3	0	-10	-2.42	-8.36	-11.63	0.22	-2.06	-4.53
706	3	0	-5	-2.09	-2.17	-11.62	0.24	-4.41	-3.32
659	3	0	0	-2.25	1.79	-11.62	0.30	-4.38	-3.70
710	3	0	0	-2.02	1.71	-11.61	0.28	-4.59	-3.09
663	3	0	5	-2.23	6.62	-11.62	0.42	-2.69	-4.80
714	3	0	5	-2.01	6.15	-11.61	0.36	-3.08	-4.51
677	3	0	10	-2.85	15.26	-11.65	0.39	1.12	-8.74
720	3	0	10	-2.90	15.42	-11.66	0.39	1.34	-8.61
724	3	0	15	-4.37	36.49	-11.73	0.50	13.03	-14.60

* Indicates model was close to heave stop

TABLE 6.323.2 - STABILITY DATA IN BODY AXES AT PIVOT

30 deg Deadrise, L/R = 0.234, Cv = 3

RUN	Trim deg	Roll deg	Yaw deg	X lb	Y lb	Z lb	K lb-ft	M lb-ft	N lb-ft
766	3	10	-15	-1.31	-7.53	-10.42	-0.33	-2.85	1.69
762	3	10	-10	-2.69	-10.28	-10.01	-0.20	-0.90	-3.62
758	3	10	-5	-2.17	-4.20	-11.06	-0.12	-3.51	-2.84
728	3	10	0	-1.87	-0.38	-11.72	-0.02	-5.05	-2.56
754	3	10	5	-1.82	3.23	-12.35	0.12	-4.98	-4.10
732	3	10	10	-2.23	9.59	-13.49	0.16	-2.98	-6.89
744	3	10	10	-2.23	9.69	-13.51	0.16	-2.87	-7.09
750	3	10	15	-3.53	25.07	-16.29	0.26	5.97	-13.87
797	3	20	-15	-1.42	-8.73	-9.15	-0.63	-0.38	2.64
793	3	20	-10	-2.02	-8.44	-9.28	-0.51	1.23	-0.42
789	3	20	-5	-2.23	-5.84	-10.24	-0.38	-3.25	-1.06
773	3	20	0	-1.87	-2.34	-11.50	-0.36	-4.59	-2.19
777	3	20	5	-1.74	0.49	-12.52	-0.23	-5.79	-3.47
781	3	20	10	-1.83	5.16	-14.22	-0.23	-6.89	-6.64
785	3	20	15	-1.95	11.84	-16.66	-0.44	-7.34	-11.19
996	6	-10	-15	-0.97	-4.98	-12.71	0.26	-11.07	3.88
992	6	-10	-10	-0.88	-0.90	-11.99	0.28	-10.34	0.60
987	6	-10	-5	-0.49	2.19	-11.40	0.37	-8.99	-1.84
963	6	-10	0	-0.93	4.94	-10.96	0.52	-7.51	-4.13
967	6	-10	5	-1.22	9.27	-10.23	0.58	-6.29	-8.65
979	6	-10	10	-1.24	14.57	-9.29	0.50	-4.25	-14.08
983	6	-10	15	-1.88	28.58	-6.89	0.65	3.14	-24.39
866	6	0	-15	-1.22	-8.65	-11.68	0.06	-7.95	4.65
862	6	0	-10	-0.96	-3.57	-11.65	0.02	-9.72	1.89
858	6	0	-5	-0.94	-0.25	-11.65	0.18	-10.06	-0.48
842	6	0	0	-0.72	2.75	-11.63	0.37	-9.86	-3.07
846	6	0	5	-1.05	6.22	-11.66	0.50	-9.03	-6.01
850	6	0	10	-1.34	11.75	-11.69	0.52	-7.66	-11.35
854	6	0	15	-1.88	24.03	-11.75	0.49	-2.71	-20.84
925	6	10	-15	-1.40	-11.50	-9.85	-0.27	-5.26	7.07
921	6	10	-10	-0.96	-5.11	-10.93	-0.21	-7.57	2.71
917	6	10	-5	-0.78	-2.38	-11.39	-0.10	-9.37	0.99
882	6	10	0	-0.73	0.28	-11.86	0.06	-10.63	-1.36
883	6	10	0	-0.70	0.30	-11.86	0.06	-10.94	-1.45
884	6	10	0	-0.85	0.24	-11.86	0.06	-10.93	-1.44
885	6	10	0	-0.73	0.28	-11.86	0.06	-10.61	-1.36
886	6	10	0	-0.76	0.30	-11.87	0.06	-10.85	-1.47
890	6	10	5	-0.85	3.47	-12.43	0.20	-11.95	-4.52
895	6	10	10	-1.01	7.26	-13.12	0.24	-12.47	-8.65
896	6	10	10	-0.98	7.59	-13.18	0.27	-12.72	-8.77
900	6	10	15	-1.11	13.75	-14.27	0.21	-12.30	-14.31
957	6	20	-15	-1.15	-12.53	-7.86	-0.46	-3.69	9.48
953	6	20	-10	-1.10	-7.18	-9.81	-0.40	-6.29	4.59
948	6	20	-5	-0.68	-3.96	-10.93	-0.35	-8.07	1.97
930	6	20	0	-0.77	-2.08	-11.62	-0.21	-10.21	0.46
934	6	20	5	-0.59	0.06	-12.38	-0.17	-12.28	-1.61
939	6	20	10	-0.75	2.81	-13.40	-0.18	-14.48	-4.70
944	6	20	15	-0.88	6.61	-14.80	-0.28	-16.58	-9.01

* Indicates model was close to heave stop

TABLE 6.324.1 - STABILITY DATA IN BODY AXES AT PIVOT

30 deg Deadrise, L/R = 0.234, Cv = 4

RUN	Trim deg	Roll deg	Yaw deg	X lb	Y lb	Z lb	K lb-ft	M lb-ft	N lb-ft
1125 *	0	-10	-10	-9.57	-21.07	-15.38	1.20	11.13	-34.44
1121	0	-10	-5	-5.95	-7.24	-12.94	0.62	9.05	-15.54
1104	0	-10	0	-5.10	1.36	-11.43	0.31	5.86	-5.55
1109	0	-10	5	-6.96	11.72	-9.60	0.08	9.60	-6.64
1116	0	-10	15	-1.53	8.87	-10.10	0.16	-6.12	-1.89
1027	0	0	-15	-1.94	-10.75	-11.49	-0.24	6.53	-5.44
1023 *	0	0	-10	-9.98	-18.02	-11.49	0.84	2.55	-38.13
1019	0	0	-5	-6.22	-9.40	-11.49	0.62	5.26	-18.55
1006	0	0	0	-5.39	-0.94	-11.49	0.21	5.39	-8.98
1010	0	0	5	-6.04	7.91	-11.49	0.20	9.84	-5.52
1061	0	10	-15	-2.40	-9.02	-10.08	-0.36	5.12	-4.93
1057	0	10	-10	-7.65	-23.75	-7.48	0.59	8.65	-29.96
1053	0	10	-5	-7.07	-11.62	-9.62	0.49	2.79	-18.33
1038	0	10	0	-6.20	-1.94	-11.32	-0.01	2.96	-8.97
1042	0	10	5	-5.79	5.69	-12.67	0.24	8.01	-7.26
1047 *	0	10	10	-11.16	28.60	-16.71	0.08	11.15	-8.58
1099	0	20	-15	-4.21	-12.82	-7.56	-0.30	13.31	-9.92
1095	0	20	-10	-6.96	-15.76	-6.49	-0.35	18.27	-22.62
1091	0	20	-5	-6.00	-11.87	-7.91	0.17	2.57	-14.99
1066	0	20	0	-6.23	-4.75	-10.50	-0.20	1.71	-8.93
1070	0	20	5	-6.38	3.26	-13.41	-0.20	4.05	-7.19
1075	0	20	10	-7.58	18.26	-18.87	0.10	11.46	-5.98
835	3	-10	-15	-4.44	-30.76	-17.34	0.67	7.84	-12.41
831	3	-10	-10	-3.80	-10.64	-13.76	0.86	-0.84	-6.49
827	3	-10	-5	-3.46	-0.42	-11.94	0.67	-2.17	-4.38
803	3	-10	0	-3.28	6.63	-10.69	0.75	-0.49	-4.96
815	3	-10	5	-3.91	13.75	-9.47	0.63	1.19	-8.07
819	3	-10	10	-4.43	27.41	-7.09	0.61	7.72	-15.71
823	3	-10	15	-0.77	10.26	-9.92	0.54	-16.05	-12.23
696	3	0	-15	-4.92	-36.58	-11.76	-0.46	10.07	-11.20
702	3	0	-10	-3.87	-13.76	-11.71	0.24	0.94	-8.05
703	3	0	-10	-3.94	-13.88	-11.71	0.23	1.08	-8.25
707	3	0	-5	-3.38	-3.05	-11.68	0.36	-3.47	-5.26
660	3	0	0	-3.93	3.02	-11.71	0.46	-2.60	-6.06
709	3	0	0	-3.22	3.32	-11.67	0.47	-3.88	-4.82
664	3	0	5	-3.91	12.15	-11.71	0.75	-0.20	-8.78
715	3	0	5	-3.21	11.10	-11.67	0.65	-2.05	-8.62
678	3	0	10	-4.42	26.32	-11.74	0.73	5.20	-15.61
721	3	0	10	-4.55	26.44	-11.74	0.73	5.46	-15.49

* Indicates model was close to heave stop

TABLE 6.324.2 - STABILITY DATA IN BODY AXES AT PIVOT
30 deg Deadrise, L/R = 0.234, Cv = 4

RUN	Trim deg	Roll deg	Yaw deg	X lb	Y lb	Z lb	K lb-ft	M lb-ft	N lb-ft
767	3	10	-15	-1.64	-8.53	-10.27	-0.52	-7.41	4.61
768	3	10	-15	-1.54	-8.61	-10.25	-0.46	-7.69	4.65
763	3	10	-10	-3.82	-13.98	-9.42	-0.43	2.96	-6.03
759	3	10	-5	-3.39	-4.99	-10.98	-0.14	-1.96	-5.69
729	3	10	0	-2.76	1.47	-12.09	0.11	-6.13	-4.57
755	3	10	5	-2.81	7.47	-13.15	0.35	-6.76	-7.60
746	3	10	10	-3.11	17.51	-14.94	0.40	-4.88	-12.74
747	3	10	10	-3.12	17.12	-14.87	0.40	-4.86	-12.66
751	3	10	15	-5.13	41.55	-19.28	0.69	10.08	-22.51
798	3	20	-15	-1.76	-9.18	-9.00	-0.86	-4.11	5.77
794	3	20	-10	-2.83	-8.89	-9.17	-0.86	1.29	-0.04
790	3	20	-5	-3.33	-5.96	-10.26	-0.51	-1.38	-4.18
774	3	20	0	-2.46	-0.98	-12.02	-0.39	-5.32	-3.48
778	3	20	5	-2.42	3.35	-13.60	-0.29	-8.69	-5.75
782	3	20	10	-2.57	9.33	-15.78	-0.45	-11.58	-10.49
786	3	20	15	-2.51	18.78	-19.22	-0.92	-14.39	-18.18
997	6	-10	-15	-1.71	-7.02	-13.15	0.36	-16.64	6.83
993	6	-10	-10	-1.50	-1.39	-12.14	0.42	-14.90	1.20
988	6	-10	-5	-1.08	3.08	-11.30	0.52	-12.90	-3.23
964	6	-10	0	-1.59	7.03	-10.66	0.71	-10.19	-6.80
968	6	-10	5	-1.68	11.48	-9.89	0.74	-9.09	-12.31
998	6	-10	5	-1.63	11.66	-9.85	0.74	-9.03	-12.28
980	6	-10	10	-1.15	14.25	-9.34	0.65	-10.17	-16.67
999	6	-10	10	-1.35	15.30	-9.18	0.68	-9.40	-17.70
984	6	-10	15	-1.48	24.02	-7.65	0.68	-5.73	-28.10
867	6	0	-15	-2.17	-12.60	-11.78	0.00	-11.85	9.32
863	6	0	-10	-1.80	-4.93	-11.74	0.03	-14.21	3.85
859	6	0	-5	-1.34	0.38	-11.69	0.26	-14.81	-0.60
843	6	0	0	-1.10	4.84	-11.67	0.50	-14.36	-5.48
847	6	0	5	-1.07	9.40	-11.67	0.60	-13.77	-10.87
851	6	0	10	-1.23	14.97	-11.68	0.58	-13.74	-17.18
855	6	0	15	-0.82	19.08	-11.64	0.23	-14.51	-23.40
926	6	10	-15	-2.60	-16.64	-9.07	-0.46	-6.37	12.17
922	6	10	-10	-1.74	-6.70	-10.74	-0.35	-10.78	5.27
918	6	10	-5	-1.39	-2.45	-11.45	-0.11	-13.49	1.86
887	6	10	0	-1.14	1.48	-12.11	0.07	-15.16	-1.98
891	6	10	5	-1.32	5.78	-12.89	0.15	-16.61	-7.16
897	6	10	10	-1.20	10.71	-13.75	0.07	-17.60	-13.32
901	6	10	15	-0.66	17.20	-14.83	-0.21	-19.09	-21.60
902	6	10	15	-0.62	17.30	-14.85	-0.20	-19.05	-21.57
903	6	10	15	-0.62	17.28	-14.85	-0.20	-19.02	-21.54
914	6	10	15	-1.21	17.72	-14.99	-0.15	-18.97	-21.89
958	6	20	-15	-0.74	-6.75	-9.92	-0.62	-13.46	9.05
954	6	20	-10	-2.09	-8.34	-9.49	-0.62	-7.86	6.94
949	6	20	-5	-1.49	-4.04	-10.99	-0.45	-11.35	3.50
950	6	20	-5	-1.43	-4.19	-10.93	-0.47	-11.44	3.52
931	6	20	0	-1.32	-1.53	-11.88	-0.34	-14.73	1.50
935	6	20	5	-0.86	1.03	-12.77	-0.34	-17.21	-1.46
940	6	20	10	-0.91	4.07	-13.88	-0.46	-18.87	-5.36
945	6	20	15	-1.01	7.78	-15.24	-0.72	-20.59	-10.43

* Indicates model was close to heave stop

TABLE 7.300.1 - STABILITY DATA IN BODY AXES AT TRANSON

30 deg Deadrise, L/R = 0.000, Cv = 0

RUN	Trim deg	Roll deg	Yaw deg	X lb	Y lb	Z lb	K lb-ft	M lb-ft	N lb-ft
1641	-2	-10	0	-0.48	2.02	-11.30	0.89	22.47	4.00
1645	-2	-10	5	-0.46	2.04	-11.30	0.90	22.40	4.03
1648	-2	-10	10	-0.45	2.00	-11.31	0.90	22.37	3.95
1651	-2	-10	15	-0.46	2.06	-11.29	0.79	22.32	4.07
1588	-2	0	0	-0.47	0.07	-11.48	-0.00	22.86	0.16
1593	-2	0	5	-0.44	0.02	-11.48	-0.00	22.71	0.05
1607	-2	0	10	-0.45	0.07	-11.48	0.03	22.76	0.16
1610	-2	0	15	-0.45	0.08	-11.48	-0.01	22.75	0.19
1614	-2	10	0	-0.46	-1.96	-11.31	-0.90	22.52	-3.86
1618	-2	10	5	-0.47	-1.91	-11.32	-0.88	22.41	-3.73
1621	-2	10	10	-0.44	-1.91	-11.32	-0.89	22.35	-3.73
1624	-2	10	15	-0.46	-1.90	-11.32	-0.90	22.33	-3.69
1628	-2	20	0	-0.47	-3.88	-10.81	-1.67	21.14	-7.50
1632	-2	20	5	-0.45	-3.81	-10.83	-1.68	21.08	-7.34
1635	-2	20	10	-0.46	-3.84	-10.82	-1.68	21.08	-7.40
1638	-2	20	15	-0.44	-3.84	-10.82	-1.66	21.02	-7.38
1571	0	-10	0	-0.05	2.04	-11.31	0.95	17.97	3.27
1575	0	-10	5	-0.05	2.07	-11.30	0.96	17.93	3.34
1579	0	-10	10	-0.04	2.07	-11.30	0.95	17.91	3.33
1583	0	-10	15	-0.04	2.07	-11.30	0.97	17.82	3.31
1511	0	0	0	-0.04	0.07	-11.49	0.04	18.39	0.15
1527	0	0	5	-0.05	0.07	-11.49	0.04	18.48	0.15
1532	0	0	10	-0.04	0.08	-11.49	0.05	18.44	0.17
1535	0	0	15	-0.02	0.15	-11.49	0.08	18.36	0.33
1539	0	10	0	0.04	-1.99	-11.32	-0.90	17.70	-3.44
1543	0	10	5	-0.05	-1.91	-11.33	-0.87	17.94	-2.97
1547	0	10	10	-0.04	-1.91	-11.33	-0.87	17.90	-2.96
1550	0	10	15	-0.03	-1.91	-11.33	-0.88	17.86	-2.95
1553	0	20	0	-0.05	-3.85	-10.83	-1.64	17.07	-6.00
1557	0	20	5	-0.04	-3.85	-10.83	-1.67	16.95	-5.97
1561	0	20	10	-0.03	-3.88	-10.81	-1.64	17.00	-6.06
1565	0	20	15	-0.04	-3.83	-10.83	-1.64	17.00	-5.93
1374	3	-10	0	0.56	2.06	-11.29	1.00	12.62	2.42
1379	3	-10	5	0.57	2.08	-11.29	1.01	12.67	2.49
1382	3	-10	10	0.57	2.09	-11.28	1.01	12.70	2.52
1386	3	-10	15	0.58	2.11	-11.28	1.03	12.60	2.54
1301	3	0	0	0.57	0.03	-11.48	0.06	13.05	0.07
1307	3	0	0	0.56	0.07	-11.48	0.07	12.91	0.15
1689	3	0	0	0.56	0.09	-11.48	0.10	12.76	0.28
1309	3	0	5	0.57	0.07	-11.48	0.07	12.91	0.17
1313	3	0	10	0.57	0.06	-11.48	0.07	13.03	0.17
1318	3	0	15	0.57	0.07	-11.48	0.09	12.86	0.16

* Indicates model was close to heave stop

TABLE 7.300.2 - STABILITY DATA IN BODY AXES AT TRANSOM

30 deg Deadrise, L/R = 0.000, Cv = 0

RUN	Trim deg	Roll deg	Yaw deg	X lb	Y lb	Z lb	K lb-ft	M lb-ft	N lb-ft
1324	3	10	0	0.56	-1.92	-11.31	-0.82	12.80	-2.16
1328	3	10	5	0.56	-1.91	-11.32	-0.81	12.79	-2.12
1332	3	10	10	0.56	-1.90	-11.32	-0.82	12.81	-2.09
1336	3	10	15	0.57	-1.89	-11.32	-0.81	12.90	-2.09
1342	3	20	0	0.56	-3.85	-10.81	-1.63	11.99	-4.28
1359	3	20	5	0.56	-3.87	-10.80	-1.65	11.76	-4.23
1363	3	20	10	0.56	-3.82	-10.82	-1.61	11.97	-4.19
1367	3	20	15	0.57	-3.81	-10.82	-1.61	11.94	-4.16
1494	6	-10	0	1.15	2.04	-11.25	1.02	9.21	1.84
1498	6	-10	5	1.17	2.07	-11.24	1.02	9.10	1.91
1502	6	-10	10	1.16	2.10	-11.24	1.00	9.12	1.97
1506	6	-10	15	1.17	2.07	-11.24	1.00	9.14	1.92
1405	6	0	0	1.16	0.07	-11.43	0.10	9.54	0.14
1438	6	0	0	1.18	0.02	-11.43	0.10	9.06	0.05
1409	6	0	5	1.17	0.07	-11.43	0.10	9.30	0.16
1440	6	0	10	1.16	0.09	-11.43	0.10	9.61	0.22
1444	6	0	15	1.17	0.09	-11.43	0.12	9.54	0.20
1455	6	0	15	1.16	0.05	-11.43	0.10	9.59	0.12
1460	6	10	0	1.16	-1.93	-11.27	-0.80	9.13	-1.56
1464	6	10	5	1.16	-1.88	-11.28	-0.78	9.29	-1.48
1468	6	10	10	1.17	-1.88	-11.28	-0.78	9.19	-1.46
1472	6	10	15	1.17	-1.86	-11.28	-0.79	8.95	-1.38
1477	6	20	0	1.14	-3.81	-10.78	-1.61	8.75	-3.10
1481	6	20	5	1.16	-3.82	-10.78	-1.62	8.68	-3.12
1485	6	20	10	1.15	-3.82	-10.78	-1.61	8.93	-3.20
1489	6	20	15	1.16	-3.80	-10.78	-1.61	8.69	-3.07

* Indicates model was close to heave stop

TABLE 7.301.1 - STABILITY DATA IN BODY AXES AT TRANSOM

30 deg Deadrise, L/R = 0.000, Cv = 1.5

RUN	Trim deg	Roll deg	Yaw deg	X lb	Y lb	Z lb	K lb-ft	M lb-ft	N lb-ft
1642	-2	-10	0	-1.94	2.27	-11.20	0.97	25.95	5.25
1646	-2	-10	5	-2.03	3.48	-10.99	1.35	25.44	9.57
1649	-2	-10	10	-2.25	5.57	-10.61	2.09	24.88	16.24
1652	-2	-10	15	-2.69	9.08	-9.98	3.20	24.19	26.78
1589	-2	0	0	-1.88	-0.05	-11.43	0.02	26.39	-0.08
1594	-2	0	5	-2.00	1.09	-11.43	0.39	26.47	4.00
1608	-2	0	10	-2.35	3.75	-11.42	1.26	27.33	11.62
1611 *	-2	0	15	-2.87	7.99	-11.40	2.73	28.12	23.96
1615	-2	10	0	-1.97	-1.99	-11.25	-0.85	25.76	-4.87
1619	-2	10	5	-2.03	-0.92	-11.44	-0.58	26.52	-1.00
1622	-2	10	10	-2.31	1.47	-11.85	0.13	28.80	6.04
1625 *	-2	10	15	-3.14	6.53	-12.71	1.92	33.79	19.64
1629	-2	20	0	-1.80	-4.07	-10.69	-1.61	24.14	-9.44
1633	-2	20	5	-1.97	-2.98	-11.08	-1.45	25.55	-5.94
1636	-2	20	10	-2.39	-0.91	-11.82	-0.99	28.58	0.20
1639 *	-2	20	15	-3.21	3.29	-13.31	0.49	35.49	12.38
1572	0	-10	0	-1.21	2.34	-11.25	1.06	21.91	4.64
1576	0	-10	5	-1.31	3.13	-11.12	1.31	21.65	7.23
1580	0	-10	10	-1.47	4.96	-10.79	1.86	21.32	12.15
1584	0	-10	15	-1.74	8.25	-10.21	2.81	21.08	20.92
1512	0	0	0	-1.21	-0.28	-11.49	0.03	22.58	-0.50
1528	0	0	5	-1.26	0.95	-11.49	0.40	22.68	2.91
1533	0	0	10	-1.50	3.01	-11.49	1.05	23.55	8.00
1536	0	0	15	-1.85	7.22	-11.49	2.54	24.33	17.99
1540	0	10	0	-1.09	-2.16	-11.29	-0.85	21.67	-4.59
1544	0	10	5	-1.23	-1.06	-11.48	-0.58	22.67	-1.08
1548	0	10	10	-1.48	0.98	-11.84	-0.03	24.57	4.01
1551	0	10	15	-1.86	4.61	-12.48	1.20	28.03	12.20
1554	0	20	0	-1.17	-3.85	-10.83	-1.57	20.74	-7.51
1558	0	20	5	-1.18	-3.22	-11.06	-1.44	21.68	-5.51
1562	0	20	10	-1.39	-1.37	-11.73	-1.06	24.32	-0.93
1566	0	20	15	-1.92	2.06	-12.98	-0.01	29.74	7.02
1375	3	-10	0	-0.56	2.12	-11.34	1.12	16.12	3.25
1378	3	-10	5	-0.60	3.33	-11.13	1.50	16.16	5.61
1383	3	-10	10	-0.77	5.28	-10.79	2.15	16.50	9.13
1387	3	-10	15	-0.89	7.94	-10.33	3.02	16.69	14.17
1302	3	0	0	-0.53	0.22	-11.53	0.17	16.35	0.43
1303	3	0	0	-0.57	0.28	-11.54	0.19	16.35	0.56
1308	3	0	0	-0.54	0.05	-11.53	0.14	16.29	0.12
1310	3	0	5	-0.61	1.23	-11.54	0.55	16.57	2.54
1314	3	0	10	-0.73	3.00	-11.54	1.12	17.33	5.73
1319	3	0	15	-0.99	6.55	-11.56	2.42	18.92	12.08

* Indicates model was close to heave stop

TABLE 7.301.2 - STABILITY DATA IN BODY AXES AT TRANSOM

30 deg Deadrise, L/R = 0.000, Cv = 1.5

RUN	Trim deg	Roll deg	Yaw deg	X lb	Y lb	Z lb	K lb-ft	M lb-ft	N lb-ft
1325	3	10	0	-0.54	-1.78	-11.40	-0.77	16.26	-2.59
1329	3	10	5	-0.56	-1.12	-11.52	-0.52	16.57	-1.28
1333	3	10	10	-0.70	0.76	-11.85	0.00	17.84	2.18
1337	3	10	15	-0.90	3.96	-12.43	1.10	20.16	7.79
1343	3	20	0	-0.59	-3.80	-10.89	-1.58	15.65	-5.54
1360	3	20	5	-0.57	-3.11	-11.14	-1.37	16.07	-4.35
1364	3	20	10	-0.67	-1.78	-11.63	-0.99	17.52	-2.23
1368	3	20	15	-0.84	1.03	-12.67	-0.21	21.07	2.12
1370	3	20	15	-0.89	1.06	-12.68	-0.17	21.19	2.10
1495	6	-10	0	-0.44	2.17	-11.40	1.17	12.26	2.67
1499	6	-10	5	-0.44	3.37	-11.18	1.63	12.45	4.15
1503	6	-10	10	-0.54	5.34	-10.85	2.26	12.84	6.62
1507	6	-10	15	-0.68	8.75	-10.26	3.47	13.16	10.89
1406	6	0	0	-0.32	-0.08	-11.59	0.13	12.23	-0.09
1410	6	0	5	-0.47	1.28	-11.60	0.67	12.45	1.67
1441	6	0	10	-0.44	3.01	-11.60	1.25	13.21	3.81
1456	6	0	15	-0.60	5.96	-11.62	2.28	14.23	7.42
1461	6	10	0	-0.40	-1.92	-11.44	-0.77	12.28	-2.16
1465	6	10	5	-0.40	-0.78	-11.64	-0.30	12.66	-0.81
1469	6	10	10	-0.46	1.10	-11.97	0.35	13.43	1.58
1473	6	10	15	-0.56	3.93	-12.48	1.23	15.09	5.18
1478	6	20	0	-0.43	-3.93	-10.91	-1.64	12.06	-4.31
1482	6	20	5	-0.40	-2.44	-11.45	-1.15	12.74	-2.60
1486	6	20	10	-0.44	-0.94	-12.00	-0.56	13.97	-1.40

* Indicates model was close to heave stop

TABLE 7.303.1 - STABILITY DATA IN BODY AXES AT TRANSON

30 deg Deadrise, L/R = 0.000, Cv = 3

RUN	Trim deg	Roll deg	Yaw deg	X lb	Y lb	Z lb	K lb-ft	M lb-ft	N lb-ft
1643	-2	-10	0	-6.11	3.08	-10.91	1.44	22.24	7.45
1647	-2	-10	5	-6.96	8.87	-9.86	3.35	19.93	27.88
1650 *	-2	-10	10	-8.36	20.98	-7.68	7.38	15.98	61.88
1590	-2	0	0	-5.92	-0.21	-11.29	-0.01	22.62	-0.97
1595	-2	0	5	-6.81	5.73	-11.26	1.84	23.89	19.69
1609 *	-2	0	10	-8.31	19.70	-11.21	6.71	26.64	57.30
1616	-2	10	0	-6.01	-3.51	-10.84	-1.54	21.94	-9.69
1620	-2	10	5	-6.67	2.14	-11.82	0.24	25.96	9.52
1623 *	-2	10	10	-8.25	16.10	-14.22	5.09	34.75	46.68
1630	-2	20	0	-6.10	-5.37	-10.06	-2.33	21.35	-15.19
1634	-2	20	5	-7.67	-0.42	-11.80	-1.04	28.90	0.21
1637 *	-2	20	10	-9.08	11.28	-16.00	2.94	43.70	31.57
1573	0	-10	0	-3.20	2.01	-11.31	0.95	23.65	4.94
1577	0	-10	5	-4.00	6.40	-10.54	2.29	22.75	15.68
1581	0	-10	10	-4.79	14.55	-9.10	4.89	20.50	34.94
1585	0	-10	15	-4.10	17.88	-8.51	6.16	20.87	41.54
1513	0	0	0	-3.17	-0.03	-11.49	0.04	25.13	-0.04
1530	0	0	5	-3.85	4.14	-11.49	1.49	26.30	11.54
1534	0	0	10	-5.78	15.46	-11.49	5.21	29.11	34.67
1541	0	10	0	-3.15	-2.07	-11.30	-0.85	23.29	-4.95
1545	0	10	5	-3.83	2.11	-12.04	0.59	28.30	6.58
1549	0	10	10	-5.73	12.70	-13.91	4.16	36.03	29.25
1555	0	20	0	-3.32	-3.85	-10.83	-1.58	21.52	-8.25
1559	0	20	5	-3.68	-0.09	-12.20	-0.39	27.48	0.82
1563	0	20	10	-5.65	9.81	-15.80	2.83	40.25	26.17
1567	0	20	15	-6.72	20.53	-19.70	6.71	56.48	44.39
1376	3	-10	0	-1.91	2.26	-11.39	1.17	17.78	4.48
1380	3	-10	5	-2.13	5.43	-10.84	2.31	18.24	9.89
1668	3	-10	5	-2.20	5.24	-10.88	2.29	18.21	9.56
1384	3	-10	10	-2.86	13.09	-9.53	4.97	19.77	22.29
1388	3	-10	15	-1.21	8.39	-10.27	3.60	12.73	9.99
1305	3	0	0	-1.77	0.37	-11.60	0.19	17.56	0.75
1654	3	0	0	-1.79	-0.32	-11.60	0.37	17.48	-0.54
1311	3	0	5	-2.10	3.43	-11.62	1.41	18.40	6.58
1655	3	0	5	-2.20	3.38	-11.62	1.64	18.34	6.60
1316	3	0	10	-2.88	11.01	-11.66	4.02	21.86	19.22
1656	3	0	10	-3.04	11.00	-11.67	4.32	22.14	19.74
1320	3	0	15	-4.29	28.05	-11.73	10.09	30.17	49.79
1657	3	0	15	-4.59	29.31	-11.75	10.53	30.58	53.36

* Indicates model was close to heave stop

TABLE 7.303.2 - STABILITY DATA IN BODY AXES AT TRANSOM

30 deg Deadrise, L/R = 0.000, Cv = 3

RUN	Trim deg	Roll deg	Yaw deg	X lb	Y lb	Z lb	K lb-ft	M lb-ft	N lb-ft
1326	3	10	0	-1.91	-2.26	-11.39	-0.95	17.60	-4.28
1660	3	10	0	-1.97	-2.12	-11.42	-0.78	17.71	-4.09
1330	3	10	5	-1.90	1.15	-11.99	0.28	18.63	1.97
1659	3	10	5	-1.90	0.51	-11.87	0.16	18.39	0.67
1334	3	10	10	-2.35	6.81	-13.01	2.22	22.11	11.69
1661	3	10	10	-2.48	6.42	-12.95	2.43	22.15	11.10
1338	3	10	15	-3.33	19.00	-15.21	6.45	32.00	32.74
1662	3	10	15	-3.79	20.75	-15.54	7.12	34.29	36.19
1344	3	20	0	-1.88	-3.89	-10.93	-1.65	17.46	-7.05
1664	3	20	0	-1.97	-4.00	-10.90	-1.79	17.35	-7.48
1361	3	20	5	-1.84	-1.66	-11.74	-0.85	18.82	-3.81
1665	3	20	5	-1.92	-1.54	-11.79	-0.67	19.09	-3.70
1365	3	20	10	-1.92	2.16	-13.14	0.40	20.56	1.73
1666	3	20	10	-1.98	2.39	-13.23	0.60	21.04	2.18
1369	3	20	15	-2.31	9.25	-15.74	2.62	25.80	12.10
1371	3	20	15	-2.30	9.21	-15.73	2.60	25.67	11.90
1667	3	20	15	-2.41	9.45	-15.82	2.93	26.49	12.64
1496	6	-10	0	-0.93	2.11	-11.46	1.15	12.38	2.69
1500	6	-10	5	-1.20	4.86	-11.00	2.25	13.23	5.84
1504	6	-10	10	-1.50	10.01	-10.13	4.03	13.53	10.46
1508	6	-10	15	-2.55	22.15	-8.10	8.41	15.24	25.88
1407	6	0	0	-0.87	-0.17	-11.64	0.09	12.04	-0.23
1411	6	0	5	-1.12	2.85	-11.67	1.33	12.40	3.00
1442	6	0	10	-1.33	6.87	-11.69	2.76	13.80	7.73
1457	6	0	15	-2.13	16.82	-11.78	6.17	17.35	19.37
1462	6	10	0	-0.98	-2.30	-11.43	-0.83	12.08	-3.07
1466	6	10	5	-0.91	0.80	-11.97	0.32	11.91	0.40
1470	6	10	10	-1.12	4.04	-12.56	1.57	12.28	3.21
1474	6	10	15	-1.43	9.71	-13.60	3.51	14.36	9.30
1479	6	20	0	-1.06	-3.82	-11.02	-1.65	13.11	-4.91
1483	6	20	5	-0.90	-1.54	-11.83	-0.75	12.29	-2.30
1487	6	20	10	-0.79	0.47	-12.55	0.07	11.37	-0.90
1491	6	20	15	-0.82	2.98	-13.47	0.93	11.24	0.68

* Indicates model was close to heave stop

TABLE 7.304.1 - STABILITY DATA IN BODY AXES AT TRANSON

30 deg Deadrise, L/R = 0.000, Cv = 4

RUN	Trim deg	Roll deg	Yaw deg	X lb	Y lb	Z lb	K lb-ft	M lb-ft	N lb-ft
1644	* -2	-10	0	-11.53	3.75	-10.60	1.98	20.21	9.66
1592	* -2	0	0	-11.14	-0.83	-11.11	-0.18	19.41	-2.99
1596	* -2	0	5	-12.08	11.83	-11.08	3.95	21.85	42.49
1617	* -2	10	0	-11.59	-4.67	-10.44	-2.15	19.82	-14.32
1631	* -2	20	0	-11.29	-6.81	-9.34	-3.23	18.02	-22.62
1574	0	-10	0	-5.69	2.02	-11.31	0.78	28.16	6.04
1578	0	-10	5	-8.15	10.10	-9.89	3.43	25.90	27.22
1582	0	-10	10	-7.82	22.69	-7.67	7.50	20.14	56.22
1586	0	-10	15	-2.02	7.87	-10.28	2.77	19.16	15.89
1515	0	0	0	-5.43	-0.08	-11.49	0.00	29.76	-0.17
1531	0	0	5	-7.44	7.36	-11.49	2.55	32.59	20.56
1542	0	10	0	-5.63	-1.87	-11.34	-0.69	27.71	-5.49
1546	0	10	5	-6.93	5.26	-12.60	1.81	36.88	15.01
1556	0	20	0	-6.38	-3.82	-10.84	-1.51	24.63	-9.15
1560	0	20	5	-6.88	3.18	-13.38	0.93	38.06	8.13
1564	0	20	10	-8.75	16.65	-18.29	5.40	56.99	39.20
1568	0	20	15	-11.39	37.36	-25.83	12.75	83.09	81.56
1377	3	-10	0	-3.02	2.65	-11.38	1.26	18.97	5.18
1381	3	-10	5	-3.23	6.82	-10.65	2.80	19.64	12.39
1385	3	-10	10	-4.06	16.85	-8.93	6.41	21.62	27.12
1389	3	-10	15	-1.24	9.51	-10.07	3.86	8.72	8.05
1306	3	0	0	-2.89	0.11	-11.66	0.10	18.32	0.26
1312	3	0	5	-3.21	5.28	-11.67	2.03	19.42	9.18
1317	3	0	10	-4.26	16.18	-11.73	5.81	24.26	26.74
1322	3	0	10	-4.39	16.35	-11.74	5.94	24.54	27.17
1321	3	0	15	-6.54	43.48	-11.85	15.78	38.96	74.12

* Indicates model was close to heave stop

TABLE 7.304.2 - STABILITY DATA IN BODY AXES AT TRANSOM

30 deg Deadrise, L/R = 0.000, Cv = 4

RUN	Trim deg	Roll deg	Yaw deg	X lb	Y lb	Z lb	K lb-ft	M lb-ft	N lb-ft
1327	3	10	0	-3.03	-2.38	-11.42	-1.07	19.04	-4.54
1331	3	10	5	-2.99	2.45	-12.27	0.79	18.61	3.30
1335	3	10	10	-3.56	11.01	-13.81	3.73	22.45	16.50
1339	3	10	15	-5.59	32.66	-17.74	11.32	41.94	55.93
1340	3	10	15	-5.61	32.60	-17.73	11.33	42.04	55.93
1345	3	20	0	-2.86	-4.14	-10.90	-1.85	19.25	-8.11
1362	3	20	5	-2.63	-1.17	-11.96	-0.73	18.38	-3.16
1366	3	20	10	-2.88	3.89	-13.82	0.93	18.88	3.20
1372	3	20	15	-3.31	12.59	-17.01	3.46	22.30	13.42
1497	6	-10	0	-1.21	2.74	-11.38	1.41	9.45	2.28
1501	6	-10	5	-1.39	5.93	-10.83	2.67	10.14	4.73
1505	6	-10	10	-1.51	9.90	-10.15	4.03	10.00	7.78
1509	6	-10	15	-2.28	19.24	-8.58	7.39	10.78	14.97
1408	6	0	0	-1.08	-0.23	-11.67	0.13	8.87	-0.29
1412	6	0	5	-1.35	3.63	-11.69	1.59	9.08	2.15
1439	6	0	5	-1.29	3.50	-11.69	1.58	8.70	1.84
1443	6	0	10	-1.42	8.15	-11.70	3.23	9.34	5.35
1458	6	0	15	-1.81	14.93	-11.74	5.49	10.21	11.13
1463	6	10	0	-1.19	-3.04	-11.32	-1.12	8.96	-2.86
1467	6	10	5	-1.18	0.63	-11.97	0.18	8.90	-0.13
1471	6	10	10	-1.34	4.59	-12.68	1.63	9.02	2.11
1475	6	10	15	-1.48	10.25	-13.70	3.42	9.69	5.90
1480	6	20	0	-1.19	-4.73	-10.71	-1.97	9.62	-4.20
1484	6	20	5	-0.85	-2.50	-11.48	-1.13	8.63	-2.44
1488	6	20	10	-0.90	-0.24	-12.31	-0.37	8.19	-1.33
1492	6	20	15	-0.99	2.62	-13.36	0.48	8.44	0.04

* Indicates model was close to heave stop

TABLE 7.310.1 - STABILITY DATA IN BODY AXES AT TRANSON

30 deg Deadrise, L/R = 0.117, Cv = 0

RUN	Trim deg	Roll deg	Yaw deg	X lb	Y lb	Z lb	K lb-ft	M lb-ft	N lb-ft
563	0	-10	-15	-0.04	2.05	-11.31	0.99	18.14	3.31
560	0	-10	-10	-0.05	2.07	-11.30	1.00	18.16	3.36
555	0	-10	-5	-0.06	2.07	-11.30	1.00	18.16	3.35
527	0	-10	0	-0.03	2.11	-11.29	1.00	18.16	3.46
548	0	-10	0	-0.01	2.01	-11.31	1.00	18.17	3.25
531	0	-10	5	0.00	2.10	-11.30	1.00	18.14	3.45
535	0	-10	10	0.00	2.15	-11.29	1.01	18.16	3.57
551	0	-10	15	-0.01	2.12	-11.29	1.00	18.13	3.48
463	0	0	-15	-0.06	0.07	-11.49	0.06	18.63	0.15
460	0	0	-10	-0.07	0.07	-11.49	0.06	18.65	0.14
456	0	0	-5	-0.06	0.07	-11.49	0.07	18.61	0.13
77	0	0	0	-0.04	0.09	-11.49	0.07	18.83	0.18
441	0	0	0	-0.10	0.00	-11.49	0.05	18.69	0.02
476	0	0	0	-0.06	0.49	-11.49	0.22	18.66	0.15
446	0	0	5	-0.03	0.12	-11.49	0.09	18.72	0.27
451	0	0	10	-0.01	0.14	-11.49	0.10	18.74	0.30
454	0	0	15	-0.01	0.12	-11.49	0.08	18.59	0.26
495	0	10	-15	-0.04	-1.92	-11.33	-0.84	18.22	-3.05
491	0	10	-10	-0.05	-1.93	-11.33	-0.86	18.23	-3.07
487	0	10	-5	-0.07	-1.93	-11.33	-0.87	18.28	-3.09
466	0	10	0	-0.04	-1.90	-11.33	-0.86	18.21	-3.00
478	0	10	5	-0.04	-1.88	-11.34	-0.83	18.27	-2.96
482	0	10	10	-0.02	-1.85	-11.34	-0.82	18.31	-2.88
485	0	10	15	-0.03	-1.89	-11.33	-0.85	18.24	-2.95
522	0	20	-15	-0.02	-3.85	-10.82	-1.67	17.18	-6.09
518	0	20	-10	-0.06	-3.85	-10.83	-1.67	17.23	-6.08
514	0	20	-5	-0.09	-3.85	-10.83	-1.66	17.44	-6.23
500	0	20	0	-0.03	-3.89	-10.81	-1.66	17.31	-6.21
504	0	20	5	-0.04	-3.80	-10.84	-1.63	17.31	-5.99
508	0	20	10	-0.03	-3.82	-10.84	-1.64	17.34	-6.04
512	0	20	15	-0.03	-3.81	-10.84	-1.66	17.26	-5.99
275	3	-10	-15	0.46	2.24	-11.26	1.07	13.32	2.90
271	3	-10	-10	0.52	2.17	-11.27	1.07	13.12	2.72
266	3	-10	-5	0.56	2.12	-11.28	1.05	12.99	2.60
245	3	-10	0	0.57	2.10	-11.28	1.04	13.10	2.57
250	3	-10	5	0.58	2.12	-11.28	1.05	12.96	2.58
256	3	-10	10	0.59	2.12	-11.28	1.06	12.89	2.59
260	3	-10	15	0.61	2.13	-11.28	1.06	12.85	2.59
128	3	0	-15	0.51	0.13	-11.48	0.13	13.23	0.26
123	3	0	-10	0.53	0.11	-11.48	0.13	13.05	0.23
119	3	0	-5	0.56	0.12	-11.48	0.13	13.10	0.23
80	3	0	0	0.54	0.05	-11.48	0.10	13.17	0.12
85	3	0	5	0.56	0.13	-11.48	0.13	13.11	0.27
110	3	0	10	0.57	0.12	-11.48	0.14	13.00	0.26
114	3	0	15	0.56	0.11	-11.48	0.13	13.09	0.24

* Indicates model was close to heave stop

TABLE 7.310.2 - STABILITY DATA IN BODY AXES AT TRANSOM

30 deg Deadrise, L/R = 0.117, Cv = 0

RUN	Trim deg	Roll deg	Yaw deg	X lb	Y lb	Z lb	K lb-ft	M lb-ft	N lb-ft
190	3	10	-15	0.42	-1.68	-11.36	-0.71	13.59	-1.74
183	3	10	-10	0.41	-1.52	-11.39	-0.64	14.16	-1.48
179	3	10	-5	0.46	-1.75	-11.35	-0.74	13.43	-1.90
137	3	10	0	0.50	-1.76	-11.35	-0.75	13.45	-1.91
169	3	10	0	0.57	-1.89	-11.32	-0.78	13.03	-2.15
145	3	10	5	0.56	-1.85	-11.33	-0.78	13.09	-2.04
149	3	10	10	0.58	-1.84	-11.33	-0.78	13.03	-2.01
239	3	20	-15	0.40	-3.61	-10.91	-1.50	13.17	-4.12
234	3	20	-10	0.48	-3.72	-10.86	-1.55	12.72	-4.23
230	3	20	-5	0.53	-3.77	-10.84	-1.57	12.51	-4.28
196	3	20	0	0.56	-3.79	-10.83	-1.58	12.41	-4.32
203	3	20	5	0.58	-3.78	-10.83	-1.58	12.37	-4.26
208	3	20	10	0.59	-3.79	-10.83	-1.58	12.33	-4.29
209	3	20	10	0.59	-3.81	-10.82	-1.59	12.30	-4.31
213	3	20	15	0.62	-3.79	-10.83	-1.58	12.26	-4.27
227	3	20	15	0.60	-3.79	-10.83	-1.59	12.33	-4.29
436	6	-10	-15	0.98	2.43	-11.20	1.15	10.52	2.92
432	6	-10	-10	1.07	2.26	-11.22	1.11	9.93	2.44
428	6	-10	-5	1.12	2.24	-11.22	1.11	9.71	2.35
403	6	-10	0	1.08	2.90	-11.10	1.26	11.31	4.20
407	6	-10	5	1.15	2.13	-11.23	1.07	9.54	2.12
411	6	-10	10	1.18	2.15	-11.23	1.08	9.49	2.16
424	6	-10	15	1.18	2.09	-11.24	1.06	9.53	2.03
323	6	0	-15	1.09	0.25	-11.44	0.20	10.03	0.54
317	6	0	-10	1.10	0.28	-11.44	0.21	10.02	0.60
311	6	0	-5	1.14	0.19	-11.43	0.18	9.87	0.41
289	6	0	0	1.13	0.23	-11.43	0.20	10.16	0.50
295	6	0	5	1.17	0.15	-11.43	0.18	9.68	0.33
298	6	0	10	1.17	0.17	-11.43	0.18	9.61	0.39
302	6	0	15	1.19	0.15	-11.43	0.18	9.59	0.33
308	6	0	15	1.20	0.15	-11.43	0.17	9.57	0.32
364	6	10	-15	1.07	-1.77	-11.31	-0.70	9.96	-1.36
359	6	10	-10	1.11	-1.82	-11.29	-0.71	9.73	-1.46
346	6	10	-5	1.14	-1.85	-11.28	-0.73	9.51	-1.47
355	6	10	-5	1.12	-1.83	-11.29	-0.72	9.70	-1.47
329	6	10	0	1.15	-1.89	-11.28	-0.74	9.55	-1.55
334	6	10	5	1.16	-1.85	-11.28	-0.73	9.51	-1.43
338	6	10	10	1.17	-1.84	-11.28	-0.73	9.48	-1.41
342	6	10	15	1.19	-1.83	-11.28	-0.73	9.44	-1.38
369	6	10	15	1.17	-1.83	-11.28	-0.73	9.52	-1.41
397	6	20	-15	1.12	-3.78	-10.79	-1.56	9.15	-3.22
393	6	20	-10	1.13	-3.80	-10.79	-1.56	9.18	-3.27
389	6	20	-5	1.16	-3.78	-10.79	-1.56	9.14	-3.21
372	6	20	0	1.14	-3.77	-10.80	-1.56	9.19	-3.20
376	6	20	5	1.21	-3.79	-10.78	-1.56	9.04	-3.19
381	6	20	10	1.18	-3.77	-10.79	-1.56	9.14	-3.16
385	6	20	15	1.19	-3.77	-10.79	-1.56	9.10	-3.15

* Indicates model was close to heave stop

TABLE 7.311.1 - STABILITY DATA IN BODY AXES AT TRANSOM

30 deg Deadrise, L/R = 0.117, Cv = 1.5

RUN	Trim deg	Roll deg	Yaw deg	X lb	Y lb	Z lb	K lb-ft	M lb-ft	N lb-ft
564 *	0	-10	-15	-2.11	-6.11	-12.74	-1.62	28.66	-18.59
561	0	-10	-10	-1.61	-1.15	-11.87	0.07	24.73	-5.83
556	0	-10	-5	-1.32	1.02	-11.49	0.72	22.95	0.03
528	0	-10	0	-1.16	2.12	-11.29	0.98	22.27	3.55
532	0	-10	5	-1.26	3.00	-11.14	1.23	22.26	6.17
536	0	-10	10	-1.48	4.81	-10.82	1.80	22.20	10.73
550	0	-10	15	-1.84	7.99	-10.26	2.73	22.25	18.96
464 *	0	0	-15	-2.01	-8.68	-11.49	-2.90	23.97	-24.06
461	0	0	-10	-1.65	-3.56	-11.49	-1.06	23.51	-10.78
457	0	0	-5	-1.43	-1.15	-11.49	-0.33	22.95	-4.36
78	0	0	0	-1.19	0.05	-11.49	0.03	22.65	-0.67
443	0	0	0	-1.29	-0.01	-11.49	0.02	22.76	-0.81
448	0	0	5	-1.29	1.05	-11.49	0.38	23.22	2.19
452	0	0	10	-1.53	2.96	-11.49	0.98	24.30	6.66
455 *	0	0	15	-2.21	7.68	-11.49	2.59	26.61	17.39
496	0	10	-15	-1.82	-9.10	-10.06	-2.99	20.21	-24.87
492	0	10	-10	-1.58	-5.44	-10.71	-1.85	21.16	-14.61
488	0	10	-5	-1.40	-3.18	-11.11	-1.18	21.69	-8.33
467	0	10	0	-1.23	-1.93	-11.33	-0.83	22.17	-4.65
479	0	10	5	-1.23	-1.11	-11.47	-0.63	23.04	-2.15
483	0	10	10	-1.49	0.66	-11.78	-0.17	25.00	2.07
486 *	0	10	15	-2.05	4.57	-12.47	1.11	29.20	10.36
523	0	20	-15	-2.12	-10.58	-8.38	-3.48	16.92	-28.29
519	0	20	-10	-1.61	-6.74	-9.77	-2.42	18.80	-17.01
515	0	20	-5	-1.45	-4.91	-10.44	-1.91	20.09	-11.69
501	0	20	0	-1.24	-4.02	-10.76	-1.72	20.66	-8.65
505	0	20	5	-1.22	-3.14	-11.08	-1.50	21.97	-6.29
509	0	20	10	-1.43	-1.68	-11.62	-1.19	24.52	-2.89
513	0	20	15	-2.00	1.75	-12.87	-0.16	30.25	4.43
276	3	-10	-15	-0.96	-2.42	-12.16	-0.42	20.43	-5.53
272	3	-10	-10	-0.76	-0.02	-11.73	0.43	17.95	-1.45
267	3	-10	-5	-0.66	1.55	-11.45	0.91	16.82	1.59
246	3	-10	0	-0.57	2.49	-11.27	1.20	16.47	3.51
249	3	-10	5	-0.65	3.51	-11.10	1.54	16.68	5.41
251	3	-10	5	-0.64	3.50	-11.10	1.54	16.69	5.38
253	3	-10	5	-0.63	3.52	-11.10	1.54	16.70	5.42
257	3	-10	10	-0.84	5.68	-10.73	2.23	17.20	9.08
261	3	-10	15	-1.01	8.79	-10.19	3.26	17.08	14.75
129	3	0	-15	-0.99	-6.42	-11.56	-2.19	18.76	-13.33
124	3	0	-10	-0.78	-2.57	-11.55	-0.78	17.34	-5.83
120	3	0	-5	-0.66	-0.68	-11.54	-0.14	16.73	-2.10
81	3	0	0	-0.63	0.32	-11.54	0.22	16.61	0.07
87	3	0	5	-0.44	0.37	-11.53	0.24	16.54	0.16
107	3	0	5	-0.66	1.44	-11.54	0.65	17.03	2.28
111	3	0	10	-0.81	3.45	-11.55	1.29	18.02	5.64
115	3	0	15	-1.07	7.24	-11.56	2.59	19.91	11.92
135	3	0	15	-1.13	7.46	-11.57	2.67	20.02	12.40

* Indicates model was close to heave stop

TABLE 7.311.2 - STABILITY DATA IN BODY AXES AT TRANSOM

30 deg Deadrise, L/R = 0.117, Cv = 1.5

RUN	Trim deg	Roll deg	Yaw deg	X lb	Y lb	Z lb	K lb-ft	M lb-ft	N lb-ft
188	3	10	-15	-0.95	-5.77	-10.72	-2.09	18.70	-10.54
184	3	10	-10	-0.93	-4.61	-10.92	-1.72	17.08	-8.73
180	3	10	-5	-0.82	-2.64	-11.26	-1.07	16.97	-4.90
138	3	10	0	-0.66	-1.63	-11.43	-0.72	16.88	-2.86
144	3	10	5	-0.62	-0.78	-11.58	-0.45	17.14	-1.34
146	3	10	5	-0.62	-0.73	-11.59	-0.42	17.16	-1.25
150	3	10	10	-0.71	0.95	-11.89	0.10	18.42	1.54
170	3	10	15	-0.99	4.30	-12.49	1.23	21.13	6.96
173	3	10	15	-0.99	4.34	-12.50	1.26	21.14	7.07
174	3	10	15	-1.01	4.39	-12.51	1.27	21.17	7.16
240	3	20	-15	-1.06	-6.89	-9.79	-2.50	17.77	-12.23
235	3	20	-10	-0.79	-5.83	-10.17	-2.24	15.79	-10.05
231	3	20	-5	-0.75	-4.59	-10.61	-1.87	15.75	-7.66
197	3	20	0	-0.61	-3.62	-10.96	-1.56	15.96	-5.77
204	3	20	5	-0.57	-2.77	-11.27	-1.32	16.63	-4.36
210	3	20	10	-0.69	-1.30	-11.81	-0.91	18.17	-2.23
214	3	20	15	-0.93	1.52	-12.85	-0.07	21.91	1.83
437	6	-10	-15	-0.53	-1.55	-12.06	-0.25	15.22	-1.38
433	6	-10	-10	-0.46	0.04	-11.77	0.28	13.70	0.05
429	6	-10	-5	-0.40	1.39	-11.53	0.81	13.08	1.59
404	6	-10	0	-0.38	2.67	-11.30	1.30	13.06	3.20
408	6	-10	5	-0.46	3.96	-11.08	1.77	13.07	4.72
412	6	-10	10	-0.58	6.20	-10.70	2.51	13.41	7.44
425	6	-10	15	-0.69	9.78	-10.08	3.76	13.84	11.77
325	6	0	-15	-0.55	-4.80	-11.61	-1.57	14.57	-6.23
318	6	0	-10	-0.45	-2.21	-11.60	-0.70	13.61	-2.95
312	6	0	-5	-0.40	-0.66	-11.60	-0.16	12.97	-0.97
290	6	0	0	-0.21	0.60	-11.58	0.35	12.93	0.69
294	6	0	5	-0.37	1.88	-11.59	0.84	13.20	2.21
299	6	0	10	-0.53	3.89	-11.61	1.53	13.95	4.61
303	6	0	15	-0.60	7.10	-11.62	2.59	15.20	8.52
309	6	0	15	-0.61	7.22	-11.62	2.63	15.18	8.70
365	6	10	-15	-0.57	-7.12	-10.54	-2.63	13.68	-9.12
360	6	10	-10	-0.46	-4.39	-11.01	-1.65	13.03	-5.65
347	6	10	-5	-0.45	-2.72	-11.30	-1.10	12.77	-3.48
330	6	10	0	-0.36	-1.54	-11.50	-0.64	12.74	-1.99
335	6	10	5	-0.35	-0.19	-11.73	-0.11	13.20	-0.34
339	6	10	10	-0.47	1.55	-12.06	0.52	14.15	1.66
343	6	10	15	-0.59	4.42	-12.57	1.45	15.95	5.00
398	6	20	-15	-0.54	-8.29	-9.34	-3.14	12.73	-10.35
394	6	20	-10	-0.49	-6.47	-10.00	-2.52	12.00	-7.93
390	6	20	-5	-0.42	-4.69	-10.64	-1.93	12.28	-5.66
373	6	20	0	-0.38	-3.39	-11.10	-1.49	12.64	-4.04
377	6	20	5	-0.36	-2.09	-11.57	-1.02	13.34	-2.75
382	6	20	10	-0.43	-0.34	-12.22	-0.35	14.80	-1.14
386	6	20	15	-0.50	1.48	-12.89	0.28	16.30	0.78

* Indicates model was close to heave stop

TABLE 7.313.1 - STABILITY DATA IN BODY AXES AT TRANSOM

30 deg Deadrise, L/R = 0.117, Cv = 3

RUN	Trim deg	Roll deg	Yaw deg	X lb	Y lb	Z lb	K lb-ft	M lb-ft	N lb-ft
562 *	0	-10	-10	-6.44	-17.13	-14.69	-5.14	32.64	-50.29
558	0	-10	-5	-4.01	-3.02	-12.20	-0.65	28.94	-12.06
529	0	-10	0	-3.13	1.76	-11.36	0.86	24.35	2.04
533	0	-10	5	-3.94	6.13	-10.59	2.25	24.15	12.56
537	0	-10	10	-5.44	16.81	-8.70	5.71	21.74	34.92
552	0	-10	15	-3.20	14.85	-9.05	5.45	19.54	31.35
462 *	0	0	-10	-6.08	-19.53	-11.49	-6.47	25.56	-54.55
458	0	0	-5	-4.14	-4.88	-11.49	-1.54	25.11	-16.03
444	0	0	0	-3.31	-0.19	-11.49	0.00	25.34	-2.99
449	0	0	5	-3.82	4.13	-11.49	1.53	27.45	8.15
453 *	0	0	10	-7.11	19.12	-11.49	6.37	29.64	38.80
497	0	10	-15	-2.31	-7.91	-10.27	-3.41	27.61	-20.45
493	0	10	-10	-4.78	-17.07	-8.66	-5.53	18.66	-46.93
489	0	10	-5	-4.06	-6.99	-10.44	-2.31	21.93	-19.70
468	0	10	0	-3.65	-2.05	-11.31	-0.82	23.53	-6.45
480	0	10	5	-3.79	2.27	-12.07	0.70	28.46	4.03
484	0	10	10	-5.51	12.96	-13.95	4.24	34.89	25.72
524	0	20	-15	-4.06	-14.27	-7.03	-4.84	25.83	-37.19
520	0	20	-10	-5.19	-13.43	-7.34	-4.69	24.45	-38.62
516	0	20	-5	-3.99	-8.77	-9.04	-3.03	18.55	-23.19
502	0	20	0	-3.51	-4.42	-10.62	-1.81	21.66	-11.21
506	0	20	5	-3.68	-0.45	-12.06	-0.57	26.44	-1.79
510	0	20	10	-4.99	8.42	-15.29	2.45	37.52	17.96
277	3	-10	-15	-2.57	-16.64	-14.75	-5.36	30.29	-33.07
273	3	-10	-10	-2.05	-5.68	-12.79	-1.50	21.61	-12.06
269	3	-10	-5	-1.88	-0.06	-11.79	0.38	18.78	-1.49
247	3	-10	0	-1.72	3.30	-11.19	1.58	17.77	4.75
254	3	-10	5	-2.11	6.79	-10.60	2.80	18.10	10.48
258	3	-10	10	-2.63	14.67	-9.24	5.50	19.73	21.76
262	3	-10	15	-1.10	9.70	-10.03	4.01	10.66	10.93
130	3	0	-15	-2.97	-23.97	-11.66	-8.61	27.47	-47.15
125	3	0	-10	-2.28	-9.10	-11.63	-3.07	21.08	-18.91
121	3	0	-5	-2.07	-2.66	-11.61	-0.84	18.32	-6.82
82	3	0	0	-1.80	0.91	-11.60	0.49	17.64	0.34
88	3	0	5	-1.05	0.88	-11.56	0.47	17.07	0.26
101	3	0	5	-2.03	5.32	-11.61	2.13	18.37	6.87
105	3	0	5	-2.02	4.71	-11.61	1.91	18.79	6.93
112	3	0	10	-2.79	12.67	-11.65	4.67	22.55	19.23
116	3	0	15	-3.87	29.79	-11.71	10.76	31.27	47.62
132	3	0	15	-4.26	31.62	-11.73	11.41	32.43	51.73

* Indicates model was close to heave stop

TABLE 7.313.2 - STABILITY DATA IN BODY AXES AT TRANSOM

30 deg Deadrise, L/R = 0.117, Cv = 3

RUN	Trim deg	Roll deg	Yaw deg	X lb	Y lb	Z lb	K lb-ft	M lb-ft	N lb-ft
191	3	10	-15	-1.05	-7.61	-10.40	-3.03	15.08	-10.88
185	3	10	-10	-2.28	-10.86	-9.89	-3.99	19.56	-20.60
181	3	10	-5	-2.01	-4.76	-10.95	-1.84	18.36	-10.02
141	3	10	0	-1.84	-1.33	-11.55	-0.60	17.81	-3.80
147	3	10	5	-1.69	2.03	-12.13	0.71	18.71	1.85
151	3	10	10	-2.15	7.82	-13.18	2.73	22.44	10.98
175	3	10	15	-3.34	21.76	-15.70	7.62	34.30	32.80
241	3	20	-15	-1.15	-8.65	-9.16	-3.52	15.61	-11.73
236	3	20	-10	-1.79	-8.46	-9.26	-3.34	17.70	-14.56
232	3	20	-5	-2.02	-6.33	-10.05	-2.54	17.03	-11.58
200	3	20	0	-1.81	-3.00	-11.25	-1.41	18.02	-6.60
206	3	20	5	-1.58	-0.35	-12.20	-0.39	18.73	-2.64
211	3	20	10	-1.71	3.47	-13.60	0.87	20.36	2.33
215	3	20	15	-1.89	10.09	-16.02	2.92	24.00	10.77
216	3	20	15	-1.90	9.93	-15.96	2.88	24.26	10.71
438	6	-10	-15	-0.79	-6.37	-12.94	-1.97	13.04	-5.71
434	6	-10	-10	-0.80	-2.23	-12.21	-0.55	12.14	-1.81
430	6	-10	-5	-0.74	0.74	-11.68	0.57	12.14	1.05
405	6	-10	0	-0.87	3.50	-11.21	1.68	12.85	4.20
409	6	-10	5	-1.34	7.33	-10.58	3.12	13.30	7.94
413	6	-10	10	-1.46	12.62	-9.66	4.89	13.58	12.89
426	6	-10	15	-1.65	21.85	-8.05	8.12	14.99	22.52
326	6	0	-15	-1.20	-11.46	-11.68	-3.96	15.25	-13.69
319	6	0	-10	-1.02	-5.19	-11.66	-1.84	13.13	-6.12
315	6	0	-5	-1.00	-1.60	-11.66	-0.48	12.14	-2.02
292	6	0	0	-0.88	1.47	-11.65	0.75	12.09	1.35
296	6	0	5	-1.04	4.62	-11.66	2.00	12.80	4.80
300	6	0	10	-1.37	9.51	-11.70	3.78	14.13	9.71
304	6	0	15	-1.63	18.21	-11.72	6.73	17.16	18.74
366	6	10	-15	-1.45	-15.28	-9.19	-5.59	14.18	-17.84
361	6	10	-10	-1.26	-7.34	-10.57	-2.77	13.57	-8.80
363	6	10	-10	-1.21	-7.44	-10.55	-2.82	13.53	-9.01
357	6	10	-5	-1.06	-3.50	-11.23	-1.42	12.78	-4.75
331	6	10	0	-0.83	-0.83	-11.67	-0.31	11.99	-1.51
336	6	10	5	-0.85	2.17	-12.20	0.87	11.79	1.52
340	6	10	10	-1.05	5.87	-12.88	2.24	12.30	4.84
344	6	10	15	-1.18	11.35	-13.86	4.08	14.26	10.25
400	6	20	-15	-1.07	-13.37	-7.55	-5.03	10.42	-13.17
395	6	20	-10	-1.10	-9.38	-9.00	-3.63	12.13	-10.34
391	6	20	-5	-1.14	-5.15	-10.55	-2.19	12.94	-6.49
374	6	20	0	-0.92	-2.67	-11.43	-1.20	12.67	-3.74
378	6	20	5	-0.69	-0.53	-12.18	-0.37	11.83	-1.51
383	6	20	10	-0.71	1.92	-13.07	0.51	11.53	0.53
387	6	20	15	-0.80	4.89	-14.16	1.44	11.77	2.69

* Indicates model was close to heave stop

TABLE 7.314.1 - STABILITY DATA IN BODY AXES AT TRANSOM

30 deg Deadrise, L/R = 0.117, Cv = 4

RUN	Trim deg	Roll deg	Yaw deg	X lb	Y lb	Z lb	K lb-ft	M lb-ft	N lb-ft
559	0	-10	-5	-6.76	-6.54	-12.82	-1.89	37.27	-23.89
530	0	-10	0	-5.40	1.45	-11.41	0.66	29.15	0.56
534	0	-10	5	-8.06	10.65	-9.79	3.70	28.54	20.33
554 *	0	-10	10	-10.28	30.79	-6.24	10.50	17.60	69.10
553	0	-10	15	-1.81	8.77	-10.12	3.32	17.21	17.13
459	0	0	-5	-7.55	-7.76	-11.49	-2.29	30.27	-27.80
445	0	0	0	-5.35	-0.47	-11.49	-0.07	29.32	-5.64
450	0	0	5	-6.88	7.62	-11.49	2.77	33.22	14.43
498	0	10	-15	-1.97	-8.16	-10.23	-2.93	21.36	-17.76
494	0	10	-10	-7.90	-27.07	-6.89	-8.67	15.34	-77.94
490	0	10	-5	-7.30	-10.23	-9.86	-3.13	23.97	-33.48
469	0	10	0	-6.39	-1.84	-11.34	-0.67	26.15	-8.22
481	0	10	5	-6.83	6.02	-12.73	2.27	36.09	10.95
525	0	20	-15	-3.80	-12.27	-7.76	-4.31	24.71	-27.99
521	0	20	-10	-7.79	-17.89	-5.72	-6.35	30.36	-54.60
517	0	20	-5	-6.91	-12.15	-7.80	-3.93	18.48	-36.81
503	0	20	0	-6.32	-4.35	-10.65	-1.65	23.46	-14.04
507	0	20	5	-6.67	3.24	-13.41	0.92	33.01	4.99
278	3	-10	-15	-4.15	-29.92	-17.18	-9.98	39.71	-59.18
274	3	-10	-10	-3.11	-9.91	-13.60	-2.84	22.80	-18.92
270	3	-10	-5	-2.83	-0.68	-11.95	0.17	18.96	-2.51
248	3	-10	0	-2.85	4.24	-11.09	1.96	19.45	6.15
255	3	-10	5	-3.31	9.44	-10.19	3.77	19.05	13.90
259	3	-10	10	-3.75	19.64	-8.42	7.38	20.92	27.64
265	3	-10	15	-1.01	10.51	-9.88	4.10	7.06	8.98
131	3	0	-15	-4.96	-41.63	-11.77	-15.16	36.12	-81.46
126	3	0	-10	-3.67	-14.51	-11.70	-4.97	23.93	-29.86
122	3	0	-5	-2.95	-3.88	-11.66	-1.25	18.91	-8.99
83	3	0	0	-2.87	1.60	-11.66	0.80	18.16	0.89
106	3	0	5	-3.12	7.55	-11.67	3.03	19.55	10.42
113	3	0	10	-3.98	18.81	-11.71	6.95	24.11	26.45
117	3	0	15	-6.45	52.46	-11.84	19.04	42.81	83.53
133	3	0	15	-7.87	60.68	-11.92	21.87	48.10	101.97

* Indicates model was close to heave stop

TABLE 7.314.2 - STABILITY DATA IN BODY AXES AT TRANSOM

30 deg Deadrise, L/R = 0.117, Cv = 4

RUN	Trim deg	Roll deg	Yaw deg	X lb	Y lb	Z lb	K lb-ft	M lb-ft	N lb-ft
192	3	10	-15	-1.38	-10.07	-9.98	-3.76	10.13	-11.28
193	3	10	-15	-1.35	-10.34	-9.93	-3.84	10.85	-11.59
186	3	10	-10	-2.77	-12.60	-9.61	-4.60	19.89	-22.01
182	3	10	-5	-2.62	-5.29	-10.89	-2.02	19.09	-11.05
143	3	10	0	-2.68	-0.93	-11.66	-0.38	17.94	-3.68
148	3	10	5	-2.75	4.37	-12.60	1.66	18.05	4.23
153	3	10	10	-3.11	13.23	-14.18	4.69	22.04	16.69
178	3	10	15	-5.14	35.99	-18.30	12.81	42.43	53.38
243	3	20	-15	-1.18	-7.56	-9.56	-3.19	10.32	-7.03
238	3	20	-10	-1.91	-7.79	-9.52	-3.28	15.66	-10.98
233	3	20	-5	-2.90	-6.64	-9.99	-2.74	18.61	-12.87
201	3	20	0	-2.40	-2.91	-11.32	-1.44	18.41	-6.70
202	3	20	0	-2.38	-2.87	-11.33	-1.41	18.41	-6.54
207	3	20	5	-2.27	0.89	-12.70	0.01	17.79	-1.03
212	3	20	10	-2.51	6.14	-14.62	1.64	18.82	4.97
229	3	20	15	-2.75	15.04	-17.87	4.23	22.36	14.90
439	6	-10	-15	-0.98	-7.23	-13.11	-2.01	9.46	-4.42
435	6	-10	-10	-0.95	-2.52	-12.28	-0.48	9.00	-1.29
431	6	-10	-5	-0.64	1.35	-11.56	0.89	8.67	1.54
406	6	-10	0	-1.16	4.83	-11.00	2.21	9.30	4.36
410	6	-10	5	-1.36	8.41	-10.39	3.56	10.13	7.54
414	6	-10	10	-1.41	12.63	-9.66	4.99	8.84	9.53
427	6	-10	15	-1.35	18.03	-8.70	6.82	8.66	13.08
327	6	0	-15	-1.32	-12.76	-11.69	-4.41	9.76	-10.68
322	6	0	-10	-1.19	-6.22	-11.68	-2.18	8.96	-4.61
316	6	0	-5	-1.25	-1.86	-11.69	-0.54	8.45	-1.31
293	6	0	0	-1.18	2.31	-11.68	1.09	8.60	1.81
297	6	0	5	-1.31	6.48	-11.69	2.68	8.98	4.89
301	6	0	10	-1.32	11.23	-11.69	4.33	9.06	8.21
306	6	0	15	-1.31	17.24	-11.69	6.27	9.14	12.77
368	6	10	-15	-1.81	-16.38	-9.04	-6.03	10.74	-14.90
362	6	10	-10	-1.15	-7.79	-10.48	-3.01	10.14	-6.67
358	6	10	-5	-1.08	-4.10	-11.12	-1.61	9.52	-3.29
333	6	10	0	-0.89	-0.92	-11.66	-0.39	8.61	-0.86
337	6	10	5	-1.11	3.03	-12.38	1.07	8.69	2.08
341	6	10	10	-1.34	7.80	-13.25	2.74	8.93	5.26
345	6	10	15	-1.38	14.01	-14.35	4.73	9.57	9.44
370	6	10	15	-1.40	14.06	-14.36	4.77	9.60	9.36
401	6	20	-15	-1.09	-12.78	-7.77	-4.92	8.53	-9.00
396	6	20	-10	-1.40	-9.58	-8.97	-3.81	9.92	-7.99
392	6	20	-5	-1.12	-5.44	-10.44	-2.34	10.69	-5.21
375	6	20	0	-0.99	-3.26	-11.22	-1.46	9.18	-2.83
379	6	20	5	-0.78	-0.88	-12.06	-0.62	8.31	-0.84
380	6	20	5	-0.76	-0.87	-12.06	-0.62	8.25	-0.88
384	6	20	10	-0.81	1.74	-13.02	0.21	8.29	0.74
388	6	20	15	-1.00	5.44	-14.39	1.30	8.60	2.98

* Indicates model was close to heave stop

TABLE 7.320.1 - STABILITY DATA IN BODY AXES AT TRANSON

30 deg Deadrise, L/R = 0.234, Cv = 0

RUN	Trim deg	Roll deg	Yaw deg	X lb	Y lb	Z lb	K lb-ft	M lb-ft	N lb-ft
1126	0	-10	-15	0.04	1.83	-11.34	0.89	17.95	2.87
1122	0	-10	-10	0.02	1.71	-11.37	0.87	18.09	2.67
1117	0	-10	-5	0.03	1.69	-11.37	0.87	18.07	2.64
1101	0	-10	0	-0.02	1.72	-11.36	0.87	18.12	2.71
1105	0	-10	5	-0.01	1.75	-11.36	0.88	18.12	2.77
1110	0	-10	10	-0.02	1.73	-11.36	0.89	18.19	2.72
1113	0	-10	15	-0.05	1.90	-11.33	0.90	18.27	3.04
1024	0	0	-15	0.06	-0.15	-11.49	-0.01	18.36	-0.25
1020	0	0	-10	0.04	-0.27	-11.49	-0.01	18.40	-0.48
1016	0	0	-5	0.01	-0.25	-11.49	-0.01	18.45	-0.42
1003	0	0	0	-0.01	-0.04	-11.49	0.03	18.62	-0.04
1085	0	0	0	0.03	-0.32	-11.49	-0.04	18.35	-0.60
1007	0	0	5	-0.01	-0.20	-11.49	0.01	18.60	-0.34
1011	0	0	10	-0.01	-0.31	-11.49	-0.03	18.58	-0.55
1014	0	0	15	-0.03	-0.15	-11.49	-0.03	18.60	-0.24
1058	0	10	-15	0.03	-2.09	-11.30	-0.92	17.86	-3.33
1054	0	10	-10	0.03	-2.13	-11.29	-0.96	17.88	-3.39
1050	0	10	-5	0.02	-2.10	-11.30	-0.94	17.91	-3.33
1035	0	10	0	-0.01	-2.09	-11.30	-0.89	18.08	-3.36
1039	0	10	5	-0.01	-2.22	-11.28	-0.92	17.94	-3.58
1043	0	10	10	-0.02	-2.23	-11.27	-0.91	17.95	-3.60
1048	0	10	15	-0.04	-2.13	-11.29	-0.94	18.00	-3.42
1096	0	20	-15	0.04	-4.26	-10.68	-1.74	16.62	-6.71
1092	0	20	-10	0.03	-4.21	-10.69	-1.73	16.68	-6.65
1087	0	20	-5	-0.01	-4.16	-10.71	-1.71	16.80	-6.55
1063	0	20	0	-0.02	-4.05	-10.75	-1.71	16.95	-6.39
1067	0	20	5	-0.02	-4.02	-10.76	-1.72	16.95	-6.33
1072	0	20	10	-0.04	-4.16	-10.71	-1.72	16.85	-6.60
1076	0	20	15	-0.04	-4.17	-10.71	-1.72	16.85	-6.62
832	3	-10	-15	0.65	1.89	-11.31	0.96	12.75	2.15
828	3	-10	-10	0.66	1.80	-11.33	0.93	12.71	2.00
824	3	-10	-5	0.65	1.80	-11.33	0.98	12.74	1.96
800	3	-10	0	0.64	1.78	-11.34	0.97	12.79	1.95
816	3	-10	10	0.62	1.78	-11.34	0.97	12.83	1.91
820	3	-10	15	0.60	1.75	-11.34	0.96	12.79	1.85
692	3	0	-15	0.66	-0.06	-11.47	0.06	12.89	-0.06
688	3	0	-10	0.66	-0.20	-11.47	-0.00	12.85	-0.31
699	3	0	-10	0.65	-0.05	-11.47	0.07	12.88	-0.03
684	3	0	-5	0.66	-0.05	-11.47	0.06	12.93	-0.07
704	3	0	-5	0.65	-0.16	-11.47	0.01	12.79	-0.23
657	3	0	0	0.64	-0.06	-11.47	0.06	12.99	-0.07
708	3	0	0	0.62	-0.09	-11.47	0.04	12.98	-0.13
661	3	0	5	0.63	-0.07	-11.47	0.04	12.93	-0.07
712	3	0	5	0.63	-0.12	-11.47	0.03	12.97	-0.18
675	3	0	10	0.61	-0.09	-11.47	0.04	12.94	-0.16
718	3	0	10	0.63	-0.03	-11.47	0.07	12.89	-0.00
679	3	0	15	0.60	-0.09	-11.47	0.04	12.97	-0.16
722	3	0	15	0.62	-0.16	-11.47	0.00	12.97	-0.26

* Indicates model was close to heave stop

TABLE 7.320.2 - STABILITY DATA IN BODY AXES AT TRANSOM

30 deg Deadrise, L/R = 0.234, Cv = 0

RUN	Trim deg	Roll deg	Yaw deg	X lb	Y lb	Z lb	K lb-ft	M lb-ft	N lb-ft
764	3	10	-15	0.67	-2.14	-11.27	-0.89	12.55	-2.50
760	3	10	-10	0.65	-2.06	-11.29	-0.86	12.69	-2.38
756	3	10	-5	0.65	-2.22	-11.26	-0.88	12.56	-2.66
726	3	10	0	0.63	-2.10	-11.28	-0.88	12.64	-2.45
752	3	10	5	0.62	-2.11	-11.28	-0.89	12.72	-2.48
730	3	10	10	0.63	-2.11	-11.28	-0.88	12.67	-2.48
743	3	10	10	0.57	-2.11	-11.28	-0.88	12.83	-2.51
748	3	10	15	0.59	-2.25	-11.26	-0.89	12.70	-2.79
795	3	20	-15	0.66	-4.08	-10.72	-1.69	11.84	-4.71
791	3	20	-10	0.65	-4.03	-10.74	-1.68	11.92	-4.61
787	3	20	-5	0.66	-4.01	-10.75	-1.68	12.00	-4.59
771	3	20	0	0.62	-4.23	-10.67	-1.74	11.81	-5.02
775	3	20	5	0.61	-4.15	-10.70	-1.69	11.87	-4.87
779	3	20	10	0.61	-4.15	-10.70	-1.69	11.88	-4.86
783	3	20	15	0.59	-4.16	-10.70	-1.73	11.90	-4.90
994	6	-10	-15	1.28	1.89	-11.26	0.96	9.48	1.65
989	6	-10	-10	1.26	1.87	-11.27	0.95	9.45	1.64
985	6	-10	-5	1.26	1.86	-11.27	0.95	9.48	1.57
962	6	-10	0	1.25	1.91	-11.26	0.96	9.46	1.70
965	6	-10	5	1.23	1.91	-11.26	0.96	9.47	1.74
977	6	-10	10	1.21	1.92	-11.26	0.97	9.51	1.70
981	6	-10	15	1.22	1.91	-11.27	0.96	9.62	1.70
864	6	0	-15	1.26	-0.09	-11.42	0.06	9.47	-0.11
860	6	0	-10	1.28	-0.10	-11.42	0.06	9.43	-0.11
856	6	0	-5	1.25	-0.10	-11.42	0.05	9.44	-0.14
839	6	0	0	1.23	-0.04	-11.42	0.08	9.53	-0.00
844	6	0	5	1.23	-0.05	-11.42	0.07	9.49	-0.01
848	6	0	10	1.22	-0.10	-11.42	0.06	9.51	-0.12
852	6	0	15	1.20	-0.09	-11.43	0.07	9.57	-0.13
923	6	10	-15	1.27	-2.08	-11.23	-0.83	9.33	-1.88
919	6	10	-10	1.25	-2.08	-11.23	-0.83	9.33	-1.88
915	6	10	-5	1.24	-2.06	-11.24	-0.83	9.37	-1.84
869	6	10	0	1.23	-2.10	-11.23	-0.84	9.38	-1.89
881	6	10	0	1.21	-2.02	-11.25	-0.82	9.40	-1.75
912	6	10	0	1.22	-2.10	-11.23	-0.84	9.32	-1.90
888	6	10	5	1.23	-2.02	-11.24	-0.82	9.43	-1.75
892	6	10	10	1.22	-2.05	-11.24	-0.84	9.44	-1.82
898	6	10	15	1.21	-2.07	-11.24	-0.84	9.35	-1.86
913	6	10	15	1.20	-2.01	-11.25	-0.82	9.49	-1.78
955	6	20	-15	1.28	-4.02	-10.69	-1.66	8.88	-3.62
951	6	20	-10	1.26	-4.03	-10.69	-1.67	8.81	-3.59
946	6	20	-5	1.25	-4.00	-10.70	-1.67	8.82	-3.54
928	6	20	0	1.24	-3.98	-10.71	-1.65	8.83	-3.49
932	6	20	5	1.23	-3.95	-10.72	-1.64	8.97	-3.46
936	6	20	10	1.21	-3.98	-10.71	-1.66	8.95	-3.54
943	6	20	15	1.21	-4.01	-10.70	-1.67	8.86	-3.58

* Indicates model was close to heave stop

TABLE 7.321.1 - STABILITY DATA IN BODY AXES AT TRANSOM

30 deg Deadrise, L/R = 0.234, Cv = 1.5

RUN	Trim deg	Roll deg	Yaw deg	X lb	Y lb	Z lb	K lb-ft	M lb-ft	N lb-ft
1127	0	-10	-15	-1.76	-5.50	-12.64	-1.40	26.65	-17.93
1129 *	0	-10	-15	-1.87	-6.09	-12.74	-1.60	27.12	-20.03
1123	0	-10	-10	-1.43	-1.42	-11.92	-0.03	23.98	-7.29
1118	0	-10	-5	-1.18	0.70	-11.54	0.59	22.46	-1.29
1102	0	-10	0	-1.13	1.87	-11.34	0.89	22.22	2.47
1106	0	-10	5	-1.18	2.79	-11.18	1.17	22.51	5.01
1111	0	-10	10	-1.49	4.63	-10.85	1.75	22.96	9.16
1114	0	-10	15	-1.74	6.88	-10.45	2.40	22.44	15.22
1025	0	0	-15	-1.65	-8.56	-11.49	-2.91	22.94	-24.56
1021	0	0	-10	-1.41	-3.90	-11.49	-1.18	22.88	-12.18
1017	0	0	-5	-1.28	-1.41	-11.49	-0.38	22.40	-5.56
1004	0	0	0	-1.16	-0.06	-11.49	0.02	22.63	-1.61
1008	0	0	5	-1.25	0.92	-11.49	0.34	23.40	1.09
1012	0	0	10	-1.53	2.74	-11.49	0.91	24.88	5.03
1015 *	0	0	15	-2.19	7.43	-11.49	2.52	27.72	14.68
1059	0	10	-15	-2.13	-8.29	-10.21	-2.68	21.44	-23.01
1055	0	10	-10	-1.43	-5.68	-10.67	-1.91	20.67	-15.58
1051	0	10	-5	-1.34	-3.50	-11.05	-1.26	21.29	-9.61
1036	0	10	0	-1.22	-2.19	-11.28	-0.89	22.00	-5.81
1040	0	10	5	-1.26	-1.23	-11.45	-0.69	23.03	-3.26
1044	0	10	10	-1.50	0.40	-11.74	-0.23	25.20	0.22
1045	0	10	10	-1.54	0.61	-11.77	-0.20	25.37	0.62
1049	0	10	15	-2.13	4.46	-12.45	1.09	29.86	8.13
1097	0	20	-15	-2.25	-9.74	-8.68	-3.26	17.01	-25.48
1093	0	20	-10	-1.58	-6.64	-9.81	-2.38	18.22	-16.49
1088	0	20	-5	-1.32	-5.19	-10.34	-1.97	19.31	-12.36
1064	0	20	0	-1.24	-4.13	-10.72	-1.71	20.46	-9.41
1068	0	20	5	-1.28	-3.26	-11.04	-1.54	21.94	-7.24
1071	0	20	10	-1.49	-1.87	-11.55	-1.27	24.55	-4.46
1073	0	20	10	-1.49	-1.72	-11.60	-1.22	24.70	-4.22
1077	0	20	15	-1.98	1.39	-12.74	-0.32	29.84	1.86
833	3	-10	-15	-0.71	-2.93	-12.24	-0.50	19.25	-8.07
829	3	-10	-10	-0.64	-0.15	-11.74	0.42	17.27	-2.47
825	3	-10	-5	-0.58	1.62	-11.43	0.96	16.45	1.20
801	3	-10	0	-0.58	2.61	-11.25	1.26	16.43	3.19
813	3	-10	5	-0.63	3.86	-11.04	1.66	16.90	5.32
817	3	-10	10	-0.83	6.22	-10.63	2.39	17.81	8.97
821	3	-10	15	-1.18	10.33	-9.92	3.85	18.55	15.57
698	3	0	-15	-0.84	-5.99	-11.55	-1.97	17.96	-13.72
689	3	0	-10	-0.54	-2.31	-11.53	-0.63	17.01	-5.72
700	3	0	-10	-0.68	-2.41	-11.54	-0.64	16.96	-6.21
685	3	0	-5	-0.57	-0.60	-11.54	-0.04	16.55	-2.43
705	3	0	-5	-0.63	-0.76	-11.54	-0.12	16.50	-2.75
658	3	0	0	-0.57	0.48	-11.54	0.33	16.62	-0.15
711	3	0	0	-0.60	0.51	-11.54	0.33	16.67	-0.12
662	3	0	5	-0.60	1.58	-11.54	0.71	17.12	1.79
713	3	0	5	-0.59	1.64	-11.54	0.73	17.15	1.91
676	3	0	10	-0.79	3.76	-11.55	1.41	18.34	5.11
719	3	0	10	-0.81	3.92	-11.55	1.48	18.43	5.48

* Indicates model was close to heave stop

TABLE 7.321.2 - STABILITY DATA IN BODY AXES AT TRANSOM

30 deg Deadrise, L/R = 0.234, Cv = 1.5

RUN	Trim deg	Roll deg	Yaw deg	X lb	Y lb	Z lb	K lb-ft	M lb-ft	N lb-ft
680	3	0	15	-1.12	8.01	-11.56	2.84	20.86	11.63
723	3	0	15	-1.15	8.06	-11.57	2.84	20.92	11.79
765	3	10	-15	-0.78	-6.91	-10.51	-2.50	16.92	-14.04
761	3	10	-10	-0.71	-4.56	-10.92	-1.69	16.04	-9.20
757	3	10	-5	-0.63	-2.84	-11.22	-1.11	16.10	-5.74
727	3	10	0	-0.60	-1.64	-11.43	-0.71	16.30	-3.34
753	3	10	5	-0.64	-0.70	-11.59	-0.40	17.00	-1.85
731	3	10	10	-0.72	1.23	-11.94	0.23	18.58	1.00
749	3	10	15	-1.01	4.82	-12.59	1.44	21.85	6.39
796	3	20	-15	-0.86	-7.37	-9.61	-2.72	16.00	-13.87
792	3	20	-10	-0.70	-5.94	-10.12	-2.32	15.01	-10.61
788	3	20	-5	-0.61	-4.69	-10.57	-1.91	15.03	-8.11
772	3	20	0	-0.61	-3.64	-10.95	-1.58	15.67	-6.23
776	3	20	5	-0.65	-2.62	-11.33	-1.28	16.66	-4.76
780	3	20	10	-0.71	-0.98	-11.93	-0.79	18.37	-2.58
784	3	20	15	-0.95	1.61	-12.88	0.02	21.84	0.64
995	6	-10	-15	-0.33	-1.63	-12.05	-0.25	14.07	-2.82
990	6	-10	-10	-0.31	0.32	-11.71	0.39	13.10	-0.19
991	6	-10	-10	-0.35	0.31	-11.71	0.39	13.13	-0.25
986	6	-10	-5	-0.30	1.70	-11.46	0.92	12.85	1.59
960	6	-10	0	-0.28	2.95	-11.24	1.39	12.80	3.11
961	6	-10	0	-0.26	2.89	-11.25	1.36	12.80	2.98
966	6	-10	5	-0.33	4.44	-10.98	1.90	13.15	4.80
978	6	-10	10	-0.47	6.97	-10.55	2.76	13.65	7.55
982	6	-10	15	-0.72	11.13	-9.85	4.22	14.49	12.72
865	6	0	-15	-0.37	-4.22	-11.59	-1.36	13.58	-6.28
861	6	0	-10	-0.33	-1.92	-11.59	-0.59	12.87	-3.12
857	6	0	-5	-0.34	-0.57	-11.59	-0.10	12.62	-1.35
840	6	0	0	-0.30	0.80	-11.59	0.45	12.72	0.45
845	6	0	5	-0.36	2.25	-11.59	1.00	13.20	2.09
849	6	0	10	-0.48	4.53	-11.60	1.74	14.18	4.64
853	6	0	15	-0.68	8.55	-11.63	3.11	15.96	9.42
924	6	10	-15	-0.37	-6.34	-10.65	-2.35	12.79	-8.69
920	6	10	-10	-0.36	-4.03	-11.06	-1.54	12.57	-5.58
916	6	10	-5	-0.28	-2.40	-11.34	-0.97	12.58	-3.36
870	6	10	0	-0.33	-1.27	-11.54	-0.52	12.80	-2.05
871	6	10	0	-0.34	-1.30	-11.54	-0.55	12.61	-2.12
889	6	10	5	-0.32	0.13	-11.79	0.01	13.34	-0.42
893	6	10	10	-0.32	1.88	-12.10	0.65	14.50	1.38
894	6	10	10	-0.39	1.99	-12.12	0.69	14.49	1.52
899	6	10	15	-0.54	4.95	-12.66	1.66	16.45	4.68
956	6	20	-15	-0.39	-7.45	-9.63	-2.89	12.27	-9.55
952	6	20	-10	-0.37	-5.81	-10.22	-2.33	11.84	-7.28
947	6	20	-5	-0.29	-4.29	-10.76	-1.82	12.12	-5.39
929	6	20	0	-0.32	-3.12	-11.20	-1.39	12.53	-4.17
933	6	20	5	-0.37	-1.67	-11.73	-0.86	13.39	-2.77
937	6	20	10	-0.34	-0.10	-12.30	-0.24	14.76	-1.38
941	6	20	15	-0.48	2.01	-13.08	0.49	16.53	0.75
942	6	20	15	-0.45	1.85	-13.02	0.43	16.36	0.46

* Indicates model was close to heave stop

TABLE 7.323.1 - STABILITY DATA IN BODY AXES AT TRANSOM

30 deg Deadrise, L/R = 0.234, Cv = 3

RUN	Trim deg	Roll deg	Yaw deg	X lb	Y lb	Z lb	K lb-ft	M lb-ft	N lb-ft
1128 *	0	-10	-15	-6.43	-29.66	-16.90	-9.83	41.23	-83.38
1124	0	-10	-10	-5.21	-12.88	-13.94	-3.62	34.14	-41.56
1120	0	-10	-5	-3.46	-3.34	-12.26	-0.66	27.37	-14.55
1103	0	-10	0	-3.10	1.49	-11.40	0.82	24.36	-0.30
1108	0	-10	5	-3.52	6.06	-10.60	2.26	24.78	9.73
1112	0	-10	10	-6.21	20.35	-8.08	6.92	25.59	35.53
1115	0	-10	15	-2.00	8.71	-10.13	3.79	16.54	16.48
1026	0	0	-15	-3.03	-11.94	-11.49	-4.81	37.56	-34.32
1022	0	0	-10	-4.93	-16.15	-11.49	-4.95	24.53	-48.50
1018	0	0	-5	-3.60	-5.55	-11.49	-1.61	24.68	-20.16
1005	0	0	0	-3.27	-0.52	-11.49	-0.05	25.22	-5.98
1009	0	0	5	-3.52	4.12	-11.49	1.55	27.97	5.01
1013 *	0	0	10	-6.51	19.20	-11.49	6.45	32.56	31.91
1060	0	10	-15	-2.32	-7.70	-10.31	-3.27	29.51	-21.41
1056	0	10	-10	-4.29	-15.34	-8.96	-4.93	20.78	-44.25
1052	0	10	-5	-4.05	-7.46	-10.35	-2.46	21.52	-22.40
1037	0	10	0	-3.69	-2.53	-11.22	-0.98	23.42	-9.45
1041	0	10	5	-3.73	2.32	-12.08	0.75	27.99	0.65
1046	0	10	10	-5.90	14.96	-14.31	5.02	36.57	23.67
1098	0	20	-15	-4.90	-16.36	-6.27	-5.74	26.64	-46.93
1094	0	20	-10	-4.75	-12.53	-7.67	-4.46	25.84	-36.95
1089	0	20	-5	-3.65	-8.80	-9.02	-3.05	18.24	-24.21
1065	0	20	0	-3.58	-4.71	-10.51	-1.90	21.40	-13.50
1069	0	20	5	-3.80	-0.32	-12.11	-0.54	26.24	-4.08
1074	0	20	10	-5.02	9.28	-15.60	2.88	37.18	14.52
1078 *	0	20	15	-6.59	25.42	-21.48	8.62	54.88	41.64
834	3	-10	-15	-2.62	-16.99	-14.82	-5.26	30.48	-38.93
830	3	-10	-10	-2.28	-5.60	-12.79	-1.28	22.03	-14.68
826	3	-10	-5	-2.06	0.36	-11.73	0.65	19.03	-2.37
802	3	-10	0	-2.15	4.31	-11.04	2.01	18.16	4.99
814	3	-10	5	-2.23	8.44	-10.31	3.38	18.22	11.00
818	3	-10	10	-2.80	17.51	-8.74	6.48	20.39	23.34
822	3	-10	15	-1.26	11.19	-9.78	4.61	8.91	11.26
697	3	0	-15	-2.88	-21.28	-11.66	-7.50	25.65	-45.89
690	3	0	-10	-2.62	-9.35	-11.64	-3.02	21.16	-23.08
701	3	0	-10	-2.42	-8.36	-11.63	-2.68	20.59	-20.21
706	3	0	-5	-2.09	-2.17	-11.62	-0.51	18.09	-7.39
659	3	0	0	-2.25	1.79	-11.62	0.92	18.19	-0.34
710	3	0	0	-2.02	1.71	-11.61	0.87	17.89	0.11
663	3	0	5	-2.23	6.62	-11.62	2.71	19.88	7.61
714	3	0	5	-2.01	6.15	-11.61	2.49	19.39	7.03
677	3	0	10	-2.85	15.26	-11.65	5.67	23.96	19.88
720	3	0	10	-2.90	15.42	-11.66	5.72	24.20	20.30
724	3	0	15	-4.37	36.49	-11.73	13.12	36.55	53.83

* Indicates model was close to heave stop

TABLE 7.323.2 - STABILITY DATA IN BODY AXES AT TRANSOM

30 deg Deadrise, L/R = 0.234, Cv = 3

RUN	Trim deg	Roll deg	Yaw deg	X lb	Y lb	Z lb	K lb-ft	M lb-ft	N lb-ft
766	3	10	-15	-1.31	-7.53	-10.42	-2.94	17.15	-12.44
762	3	10	-10	-2.69	-10.28	-10.01	-3.75	18.81	-22.90
758	3	10	-5	-2.17	-4.20	-11.06	-1.57	17.97	-10.71
728	3	10	0	-1.87	-0.38	-11.72	-0.15	17.57	-3.27
754	3	10	5	-1.82	3.23	-12.35	1.24	18.80	1.96
732	3	10	10	-2.23	9.59	-13.49	3.48	23.09	11.10
744	3	10	10	-2.23	9.69	-13.51	3.51	23.23	11.08
750	3	10	15	-3.53	25.07	-16.29	8.93	37.74	33.14
797	3	20	-15	-1.42	-8.73	-9.15	-3.64	17.26	-13.73
793	3	20	-10	-2.02	-8.44	-9.28	-3.43	19.33	-16.25
789	3	20	-5	-2.23	-5.84	-10.24	-2.40	16.72	-12.01
773	3	20	0	-1.87	-2.34	-11.50	-1.17	17.61	-6.57
777	3	20	5	-1.74	0.49	-12.52	-0.06	18.28	-2.56
781	3	20	10	-1.83	5.16	-14.22	1.55	20.41	3.04
785	3	20	15	-1.95	11.84	-16.66	3.65	24.57	11.01
996	6	-10	-15	-0.97	-4.98	-12.71	-1.46	13.10	-5.45
992	6	-10	-10	-0.88	-0.90	-11.99	-0.03	12.44	-1.10
987	6	-10	-5	-0.49	2.19	-11.40	1.13	12.55	2.26
963	6	-10	0	-0.93	4.94	-10.96	2.23	13.36	5.13
967	6	-10	5	-1.22	9.27	-10.23	3.78	13.31	8.72
979	6	-10	10	-1.24	14.57	-9.29	5.53	13.61	13.24
983	6	-10	15	-1.88	28.58	-6.89	10.53	16.71	29.20
866	6	0	-15	-1.22	-8.65	-11.68	-2.93	14.38	-11.57
862	6	0	-10	-0.96	-3.57	-11.65	-1.21	12.47	-4.81
858	6	0	-5	-0.94	-0.25	-11.65	0.09	12.11	-0.95
842	6	0	0	-0.72	2.75	-11.63	1.32	12.19	2.09
846	6	0	5	-1.05	6.22	-11.66	2.65	13.20	5.66
850	6	0	10	-1.34	11.75	-11.69	4.58	14.73	10.68
854	6	0	15	-1.88	24.03	-11.75	8.81	19.97	24.23
925	6	10	-15	-1.40	-11.50	-9.85	-4.25	13.70	-14.50
921	6	10	-10	-0.96	-5.11	-10.93	-1.98	13.27	-6.87
917	6	10	-5	-0.78	-2.38	-11.39	-0.93	12.27	-3.48
882	6	10	0	-0.73	0.28	-11.86	0.15	11.86	-0.83
883	6	10	0	-0.70	0.30	-11.86	0.17	11.54	-0.88
884	6	10	0	-0.85	0.24	-11.86	0.14	11.61	-0.99
885	6	10	0	-0.73	0.28	-11.86	0.15	11.88	-0.84
886	6	10	0	-0.76	0.30	-11.87	0.17	11.67	-0.91
890	6	10	5	-0.85	3.47	-12.43	1.40	11.65	1.98
895	6	10	10	-1.01	7.26	-13.12	2.75	12.48	4.96
896	6	10	10	-0.98	7.59	-13.18	2.89	12.33	5.47
900	6	10	15	-1.11	13.75	-14.27	4.96	14.85	11.46
957	6	20	-15	-1.15	-12.53	-7.86	-4.79	11.45	-14.01
953	6	20	-10	-1.10	-7.18	-9.81	-2.88	12.48	-8.87
948	6	20	-5	-0.68	-3.96	-10.93	-1.72	12.65	-5.45
930	6	20	0	-0.77	-2.08	-11.62	-0.93	11.85	-3.45
934	6	20	5	-0.59	0.06	-12.38	-0.15	11.14	-1.50
939	6	20	10	-0.75	2.81	-13.40	0.79	10.91	0.57
944	6	20	15	-0.88	6.61	-14.80	2.01	11.48	3.38

* Indicates model was close to heave stop

TABLE 7.324.1 - STABILITY DATA IN BODY AXES AT TRANSOM

30 deg Deadrise, L/R = 0.234, Cv = 4

RUN	Trim deg	Roll deg	Yaw deg	X lb	Y lb	Z lb	K lb-ft	M lb-ft	N lb-ft
1125 *	0	-10	-10	-9.57	-21.07	-15.38	-6.08	43.28	-73.93
1121	0	-10	-5	-5.95	-7.24	-12.94	-1.89	35.38	-29.12
1104	0	-10	0	-5.10	1.36	-11.43	0.78	29.05	-2.99
1109	0	-10	5	-6.96	11.72	-9.60	4.13	30.01	15.33
1116	0	-10	15	-1.53	8.87	-10.10	3.23	13.36	14.74
1027	0	0	-15	-1.94	-10.75	-11.49	-3.96	28.75	-25.61
1023 *	0	0	-10	-9.98	-18.02	-11.49	-5.39	27.54	-71.91
1019	0	0	-5	-6.22	-9.40	-11.49	-2.63	28.95	-36.17
1006	0	0	0	-5.39	-0.94	-11.49	-0.11	28.79	-10.75
1010	0	0	5	-6.04	7.91	-11.49	2.94	33.48	9.31
1061	0	10	-15	-2.40	-9.02	-10.08	-3.48	24.85	-21.84
1057	0	10	-10	-7.65	-23.75	-7.48	-7.63	25.32	-74.49
1053	0	10	-5	-7.07	-11.62	-9.62	-3.53	23.27	-40.11
1038	0	10	0	-6.20	-1.94	-11.32	-0.68	26.34	-12.61
1042	0	10	5	-5.79	5.69	-12.67	2.20	33.77	3.41
1047 *	0	10	10	-11.16	28.60	-16.71	9.97	46.34	45.05
1099	0	20	-15	-4.21	-12.82	-7.56	-4.73	28.94	-33.95
1095	0	20	-10	-6.96	-15.76	-6.49	-5.80	32.85	-52.17
1091	0	20	-5	-6.00	-11.87	-7.91	-3.93	19.47	-37.24
1066	0	20	0	-6.23	-4.75	-10.50	-1.85	23.55	-17.83
1070	0	20	5	-6.38	3.26	-13.41	0.93	31.41	-1.08
1075	0	20	10	-7.58	18.26	-18.87	6.41	49.47	28.25
835	3	-10	-15	-4.44	-30.76	-17.34	-9.97	41.90	-70.08
831	3	-10	-10	-3.80	-10.64	-13.76	-2.82	26.28	-26.43
827	3	-10	-5	-3.46	-0.42	-11.94	0.52	21.42	-5.17
803	3	-10	0	-3.28	6.63	-10.69	3.04	20.68	7.47
815	3	-10	5	-3.91	13.75	-9.47	5.39	20.29	17.70
819	3	-10	10	-4.43	27.41	-7.09	10.08	22.54	35.67
823	3	-10	15	-0.77	10.26	-9.92	4.09	2.81	7.00
696	3	0	-15	-4.92	-36.58	-11.76	-13.11	33.83	-79.78
702	3	0	-10	-3.87	-13.76	-11.71	-4.51	24.23	-33.84
703	3	0	-10	-3.94	-13.88	-11.71	-4.57	24.41	-34.27
707	3	0	-5	-3.38	-3.05	-11.68	-0.69	19.60	-10.98
660	3	0	0	-3.93	3.02	-11.71	1.51	20.72	-0.40
709	3	0	0	-3.22	3.32	-11.67	1.62	19.12	1.40
664	3	0	5	-3.91	12.15	-11.71	4.95	23.11	14.00
715	3	0	5	-3.21	11.10	-11.67	4.48	20.95	12.20
678	3	0	10	-4.42	26.32	-11.74	9.83	28.74	33.73
721	3	0	10	-4.55	26.44	-11.74	9.87	29.05	34.09

* Indicates model was close to heave stop

TABLE 7.324.2 - STABILITY DATA IN BODY AXES AT TRANSOM
30 deg Deadrise, L/R = 0.234, Cv = 4

RUN	Trim deg	Roll deg	Yaw deg	X lb	Y lb	Z lb	K lb-ft	M lb-ft	N lb-ft
767	3	10	-15	-1.64	-8.53	-10.27	-3.47	12.41	-11.39
768	3	10	-15	-1.54	-8.61	-10.25	-3.44	12.06	-11.51
763	3	10	-10	-3.82	-13.98	-9.42	-5.26	21.95	-32.24
759	3	10	-5	-3.39	-4.99	-10.98	-1.87	19.81	-15.06
729	3	10	0	-2.76	1.47	-12.09	0.62	17.49	-1.82
755	3	10	5	-2.81	7.47	-13.15	2.93	18.86	6.41
746	3	10	10	-3.11	17.51	-14.94	6.46	24.20	20.09
747	3	10	10	-3.12	17.12	-14.87	6.32	24.10	19.44
751	3	10	15	-5.13	41.55	-19.28	15.06	48.01	55.40
798	3	20	-15	-1.76	-9.18	-9.00	-4.03	13.38	-11.43
794	3	20	-10	-2.83	-8.89	-9.17	-3.94	19.45	-16.70
790	3	20	-5	-3.33	-5.96	-10.26	-2.57	19.01	-15.35
774	3	20	0	-2.46	-0.98	-12.02	-0.73	18.08	-5.32
778	3	20	5	-2.42	3.35	-13.60	0.87	17.65	0.53
782	3	20	10	-2.57	9.33	-15.78	2.78	18.91	7.00
786	3	20	15	-2.51	18.78	-19.22	5.58	22.51	17.03
997	6	-10	-15	-1.71	-7.02	-13.15	-2.06	8.61	-6.33
993	6	-10	-10	-1.50	-1.39	-12.14	-0.06	8.37	-1.40
988	6	-10	-5	-1.08	3.08	-11.30	1.59	8.67	2.55
964	6	-10	0	-1.59	7.03	-10.66	3.14	10.35	6.38
968	6	-10	5	-1.68	11.48	-9.89	4.71	10.03	9.22
998	6	-10	5	-1.63	11.66	-9.85	4.77	10.00	9.59
980	6	-10	10	-1.15	14.25	-9.34	5.57	7.75	10.04
999	6	-10	10	-1.35	15.30	-9.18	5.97	8.27	10.99
984	6	-10	15	-1.48	24.02	-7.65	8.98	9.14	16.94
867	6	0	-15	-2.17	-12.60	-11.78	-4.35	10.99	-14.30
863	6	0	-10	-1.80	-4.93	-11.74	-1.68	8.43	-5.39
859	6	0	-5	-1.34	0.38	-11.69	0.39	7.58	0.11
843	6	0	0	-1.10	4.84	-11.67	2.17	7.90	3.60
847	6	0	5	-1.07	9.40	-11.67	3.85	8.47	6.76
851	6	0	10	-1.23	14.97	-11.68	5.75	8.59	10.89
855	6	0	15	-0.82	19.08	-11.64	6.83	7.60	12.37
926	6	10	-15	-2.60	-16.64	-9.07	-6.22	11.55	-19.04
922	6	10	-10	-1.74	-6.70	-10.74	-2.66	9.96	-7.30
918	6	10	-5	-1.39	-2.45	-11.45	-0.96	8.45	-2.73
887	6	10	0	-1.14	1.48	-12.11	0.58	7.94	0.80
891	6	10	5	-1.32	5.78	-12.89	2.15	8.02	3.68
897	6	10	10	-1.20	10.71	-13.75	3.78	8.58	6.76
901	6	10	15	-0.66	17.20	-14.83	5.74	8.94	10.65
902	6	10	15	-0.62	17.30	-14.85	5.78	9.00	10.86
903	6	10	15	-0.62	17.28	-14.85	5.77	9.03	10.87
914	6	10	15	-1.21	17.72	-14.99	5.98	9.55	11.34
958	6	20	-15	-0.74	-6.75	-9.92	-2.95	5.39	-3.62
954	6	20	-10	-2.09	-8.34	-9.49	-3.50	10.67	-8.69
949	6	20	-5	-1.49	-4.04	-10.99	-1.85	9.77	-4.09
950	6	20	-5	-1.43	-4.19	-10.93	-1.92	9.55	-4.34
931	6	20	0	-1.32	-1.53	-11.88	-0.87	8.00	-1.38
935	6	20	5	-0.86	1.03	-12.77	0.01	7.02	0.47
940	6	20	10	-0.91	4.07	-13.88	0.95	7.46	2.27
945	6	20	15	-1.01	7.78	-15.24	1.97	8.33	4.15

* Indicates model was close to heave stop

TABLE 8.301.1 - NON-DIMENSIONAL STABILITY DATA IN BODY AXES AT TRANSOM

30 deg Deadrise, L/R = 0.000, Cv = 1.5

RUN	Trim deg	Roll deg	Yaw deg	X'	Y'	Z'	K'	M'	N'
1642	-2	-10	0	-0.0659	0.0771	-0.3799	0.0437	1.1733	0.2373
1646	-2	-10	5	-0.0690	0.1183	-0.3736	0.0613	1.1532	0.4338
1649	-2	-10	10	-0.0765	0.1892	-0.3608	0.0946	1.1276	0.7360
1652	-2	-10	15	-0.0917	0.3097	-0.3401	0.1452	1.0994	1.2174
1589	-2	0	0	-0.0641	-0.0016	-0.3886	0.0007	1.1961	-0.0037
1594	-2	0	5	-0.0680	0.0370	-0.3885	0.0179	1.1998	0.1812
1608	-2	0	10	-0.0777	0.1240	-0.3777	0.0558	1.2057	0.5125
1611 *	-2	0	15	-0.0978	0.2725	-0.3885	0.1243	1.2784	1.0892
1615	-2	10	0	-0.0673	-0.0678	-0.3836	-0.0387	1.1707	-0.2213
1619	-2	10	5	-0.0692	-0.0314	-0.3900	-0.0263	1.2052	-0.0454
1622	-2	10	10	-0.0787	0.0502	-0.4040	0.0061	1.3091	0.2745
1625 *	-2	10	15	-0.1076	0.2237	-0.4358	0.0878	1.5442	0.8978
1629	-2	20	0	-0.0595	-0.1342	-0.3527	-0.0710	1.0623	-0.4155
1633	-2	20	5	-0.0664	-0.1005	-0.3735	-0.0654	1.1487	-0.2670
1636	-2	20	10	-0.0808	-0.0307	-0.3995	-0.0445	1.2885	0.0090
1639 *	-2	20	15	-0.1094	0.1121	-0.4538	0.0222	1.8130	0.5626
1572	0	-10	0	-0.0412	0.0795	-0.3816	0.0480	0.9907	0.2098
1576	0	-10	5	-0.0446	0.1063	-0.3779	0.0594	0.9816	0.3278
1580	0	-10	10	-0.0501	0.1690	-0.3679	0.0847	0.9691	0.5521
1584	0	-10	15	-0.0593	0.2813	-0.3481	0.1277	0.9581	0.9507
1512	0	0	0	-0.0413	-0.0094	-0.3906	0.0012	1.0237	-0.0228
1528	0	0	5	-0.0425	0.0320	-0.3875	0.0179	1.0198	0.1310
1533	0	0	10	-0.0508	0.1020	-0.3896	0.0474	1.0648	0.3615
1536	0	0	15	-0.0621	0.2423	-0.3854	0.1138	1.0879	0.8046
1540	0	10	0	-0.0372	-0.0734	-0.3837	-0.0387	0.9822	-0.2082
1544	0	10	5	-0.0418	-0.0361	-0.3903	-0.0262	1.0276	-0.0492
1548	0	10	10	-0.0504	0.0333	-0.4036	-0.0015	1.1168	0.1823
1551	0	10	15	-0.0638	0.1579	-0.4278	0.0548	1.2808	0.5575
1554	0	20	0	-0.0401	-0.1313	-0.3691	-0.0714	0.9425	-0.3415
1558	0	20	5	-0.0398	-0.1085	-0.3728	-0.0649	0.9748	-0.2478
1562	0	20	10	-0.0471	-0.0463	-0.3977	-0.0481	1.0993	-0.0419
1566	0	20	15	-0.0651	0.0698	-0.4400	-0.0005	1.3447	0.3172
1375	3	-10	0	-0.0186	0.0700	-0.3753	0.0495	0.7112	0.1436
1378	3	-10	5	-0.0201	0.1123	-0.3752	0.0675	0.7265	0.2521
1383	3	-10	10	-0.0260	0.1791	-0.3659	0.0971	0.7458	0.4128
1387	3	-10	15	-0.0302	0.2706	-0.3522	0.1373	0.7586	0.6440
1302	3	0	0	-0.0182	0.0077	-0.3953	0.0077	0.7472	0.0196
1303	3	0	0	-0.0197	0.0098	-0.3965	0.0086	0.7492	0.0258
1308	3	0	0	-0.0186	0.0019	-0.3964	0.0064	0.7467	0.0056
1310	3	0	5	-0.0207	0.0419	-0.3933	0.0251	0.7534	0.1153
1314	3	0	10	-0.0247	0.1019	-0.3925	0.0507	0.7855	0.2599
1319	3	0	15	-0.0335	0.2228	-0.3929	0.1099	0.8574	0.5478

* Indicates model was close to heave stop

TABLE 8.301.2 - NON-DIMENSIONAL STABILITY DATA IN BODY AXES AT TRANSOM

30 deg Deadrise, L/R = 0.000, Cv = 1.5

RUN	Trim deg	Roll deg	Yaw deg	X'	Y'	Z'	K'	M'	N'
1325	3	10	0	-0.0185	-0.0609	-0.3896	-0.0349	0.7410	-0.1182
1329	3	10	5	-0.0190	-0.0381	-0.3926	-0.0237	0.7531	-0.0582
1333	3	10	10	-0.0238	0.0260	-0.4052	0.0002	0.8131	0.0992
1337	3	10	15	-0.0307	0.1352	-0.4248	0.0500	0.9188	0.3549
1343	3	20	0	-0.0202	-0.1296	-0.3714	-0.0719	0.7115	-0.2517
1360	3	20	5	-0.0188	-0.1029	-0.3688	-0.0604	0.7089	-0.1917
1364	3	20	10	-0.0226	-0.0605	-0.3955	-0.0449	0.7942	-0.1013
1368	3	20	15	-0.0285	0.0352	-0.4318	-0.0097	0.9576	0.0965
1370	3	20	15	-0.0295	0.0353	-0.4218	-0.0076	0.9399	0.0932
1495	6	-10	0	-0.0147	0.0719	-0.3782	0.0517	0.5425	0.1182
1499	6	-10	5	-0.0149	0.1140	-0.3782	0.0737	0.5612	0.1873
1503	6	-10	10	-0.0183	0.1816	-0.3688	0.1024	0.5820	0.3001
1507	6	-10	15	-0.0231	0.2974	-0.3489	0.1571	0.5965	0.4938
1406	6	0	0	-0.0108	-0.0026	-0.3950	0.0060	0.5561	-0.0041
1410	6	0	5	-0.0156	0.0425	-0.3860	0.0297	0.5522	0.0742
1441	6	0	10	-0.0147	0.1009	-0.3890	0.0559	0.5909	0.1703
1456	6	0	15	-0.0198	0.1973	-0.3844	0.1007	0.6279	0.3274
1461	6	10	0	-0.0136	-0.0648	-0.3856	-0.0347	0.5522	-0.0972
1465	6	10	5	-0.0136	-0.0266	-0.3945	-0.0136	0.5724	-0.0366
1469	6	10	10	-0.0156	0.0372	-0.4071	0.0159	0.6088	0.0718
1473	6	10	15	-0.0191	0.1338	-0.4256	0.0560	0.6857	0.2355
1478	6	20	0	-0.0143	-0.1296	-0.3602	-0.0722	0.5308	-0.1895
1482	6	20	5	-0.0135	-0.0821	-0.3862	-0.0517	0.5729	-0.1168
1486	6	20	10	-0.0148	-0.0319	-0.4058	-0.0250	0.6297	-0.0630

* Indicates model was close to heave stop

TABLE 8.303.1 - NON-DIMENSIONAL STABILITY DATA IN BODY AXES AT TRANSOM

30 deg Deadrise, L/R = 0.000, Cv = 3

RUN	Trim deg	Roll deg	Yaw deg	X'	Y'	Z'	K'	M'	N'
1643	-2	-10	0	-0.0518	0.0261	-0.0925	0.0163	0.2514	0.0842
1647	-2	-10	5	-0.0590	0.0753	-0.0837	0.0379	0.2255	0.3155
1650 *	-2	-10	10	-0.0713	0.1791	-0.0655	0.0840	0.1819	0.7041
1590	-2	0	0	-0.0502	-0.0018	-0.0958	-0.0001	0.2559	-0.0110
1595	-2	0	5	-0.0578	0.0486	-0.0956	0.0209	0.2704	0.2228
1609 *	-2	0	10	-0.0703	0.1665	-0.0947	0.0757	0.3002	0.6459
1616	-2	10	0	-0.0510	-0.0298	-0.0920	-0.0174	0.2483	-0.1096
1620	-2	10	5	-0.0566	0.0182	-0.1003	0.0027	0.2938	0.1078
1623 *	-2	10	10	-0.0704	0.1374	-0.1214	0.0579	0.3954	0.5312
1630	-2	20	0	-0.0512	-0.0450	-0.0844	-0.0261	0.2390	-0.1701
1634	-2	20	5	-0.0650	-0.0036	-0.1000	-0.0118	0.3267	0.0023
1637 *	-2	20	10	-0.0772	0.0960	-0.1362	0.0334	0.4960	0.3583
1573	0	-10	0	-0.0271	0.0171	-0.0959	0.0108	0.2673	0.0558
1577	0	-10	5	-0.0339	0.0542	-0.0893	0.0259	0.2572	0.1772
1581	0	-10	10	-0.0406	0.1235	-0.0773	0.0554	0.2320	0.3954
1585	0	-10	15	-0.0349	0.1522	-0.0725	0.0699	0.2368	0.4714
1513	0	0	0	-0.0269	-0.0003	-0.0974	0.0004	0.2840	-0.0005
1530	0	0	5	-0.0325	0.0350	-0.0971	0.0168	0.2964	0.1300
1534	0	0	10	-0.0492	0.1316	-0.0978	0.0591	0.3303	0.3934
1541	0	10	0	-0.0267	-0.0175	-0.0959	-0.0096	0.2636	-0.0560
1545	0	10	5	-0.0325	0.0179	-0.1022	0.0067	0.3203	0.0745
1549	0	10	10	-0.0488	0.1081	-0.1184	0.0472	0.4089	0.3319
1555	0	20	0	-0.0279	-0.0323	-0.0909	-0.0177	0.2409	-0.0924
1559	0	20	5	-0.0311	-0.0007	-0.1031	-0.0044	0.3097	0.0092
1563	0	20	10	-0.0479	0.0833	-0.1341	0.0321	0.4555	0.2962
1567	0	20	15	-0.0573	0.1752	-0.1681	0.0763	0.6427	0.5051
1376	3	-10	0	-0.0159	0.0188	-0.0948	0.0129	0.1975	0.0498
1380	3	-10	5	-0.0179	0.0456	-0.0910	0.0259	0.2042	0.1108
1668	3	-10	5	-0.0185	0.0440	-0.0913	0.0256	0.2039	0.1071
1384	3	-10	10	-0.0241	0.1102	-0.0802	0.0558	0.2219	0.2502
1388	3	-10	15	-0.0102	0.0706	-0.0865	0.0404	0.1429	0.1121
1305	3	0	0	-0.0149	0.0031	-0.0977	0.0021	0.1971	0.0084
1654	3	0	0	-0.0152	-0.0027	-0.0983	0.0042	0.1976	-0.0061
1311	3	0	5	-0.0177	0.0289	-0.0978	0.0158	0.2066	0.0738
1655	3	0	5	-0.0187	0.0287	-0.0985	0.0185	0.2072	0.0746
1316	3	0	10	-0.0244	0.0931	-0.0985	0.0454	0.2464	0.2167
1656	3	0	10	-0.0258	0.0932	-0.0989	0.0489	0.2503	0.2231
1320	3	0	15	-0.0364	0.2381	-0.0996	0.1142	0.3415	0.5635
1657	3	0	15	-0.0392	0.2501	-0.1002	0.1198	0.3479	0.6072

* Indicates model was close to heave stop

TABLE 8.303.2 - NON-DIMENSIONAL STABILITY DATA IN BODY AXES AT TRANSOM

30 deg Deadrise, L/R = 0.000, Cv = 3

RUN	Trim deg	Roll deg	Yaw deg	X'	Y'	Z'	K'	M'	N'
1326	3	10	0	-0.0162	-0.0191	-0.0962	-0.0108	0.1983	-0.0483
1660	3	10	0	-0.0167	-0.0179	-0.0965	-0.0088	0.1996	-0.0461
1330	3	10	5	-0.0161	0.0097	-0.1013	0.0031	0.2099	0.0221
1659	3	10	5	-0.0161	0.0043	-0.1004	0.0018	0.2073	0.0076
1334	3	10	10	-0.0199	0.0577	-0.1103	0.0251	0.2499	0.1321
1661	3	10	10	-0.0211	0.0544	-0.1097	0.0274	0.2503	0.1255
1338	3	10	15	-0.0283	0.1612	-0.1291	0.0730	0.3622	0.3706
1662	3	10	15	-0.0323	0.1766	-0.1323	0.0808	0.3891	0.4107
1344	3	20	0	-0.0159	-0.0328	-0.0922	-0.0186	0.1963	-0.0793
1664	3	20	0	-0.0167	-0.0338	-0.0921	-0.0202	0.1955	-0.0843
1361	3	20	5	-0.0155	-0.0139	-0.0989	-0.0096	0.2113	-0.0428
1665	3	20	5	-0.0163	-0.0131	-0.0997	-0.0076	0.2151	-0.0417
1365	3	20	10	-0.0162	0.0182	-0.1106	0.0044	0.2308	0.0194
1666	3	20	10	-0.0168	0.0203	-0.1121	0.0068	0.2377	0.0246
1369	3	20	15	-0.0195	0.0782	-0.1331	0.0296	0.2908	0.1364
1371	3	20	15	-0.0193	0.0771	-0.1317	0.0290	0.2866	0.1329
1667	3	20	15	-0.0205	0.0802	-0.1343	0.0332	0.2998	0.1430
1496	6	-10	0	-0.0078	0.0177	-0.0962	0.0128	0.1386	0.0301
1500	6	-10	5	-0.0102	0.0410	-0.0930	0.0253	0.1491	0.0658
1504	6	-10	10	-0.0127	0.0849	-0.0858	0.0456	0.1529	0.1182
1508	6	-10	15	-0.0216	0.1880	-0.0687	0.0951	0.1725	0.2929
1407	6	0	0	-0.0073	-0.0015	-0.0982	0.0010	0.1354	-0.0026
1411	6	0	5	-0.0094	0.0239	-0.0977	0.0149	0.1384	0.0335
1442	6	0	10	-0.0112	0.0579	-0.0986	0.0310	0.1552	0.0869
1457	6	0	15	-0.0179	0.1416	-0.0992	0.0693	0.1948	0.2174
1462	6	10	0	-0.0082	-0.0195	-0.0966	-0.0094	0.1361	-0.0347
1466	6	10	5	-0.0077	0.0068	-0.1012	0.0036	0.1343	0.0045
1470	6	10	10	-0.0095	0.0343	-0.1065	0.0178	0.1388	0.0362
1474	6	10	15	-0.0122	0.0824	-0.1154	0.0397	0.1625	0.1053
1479	6	20	0	-0.0089	-0.0320	-0.0923	-0.0184	0.1464	-0.0548
1483	6	20	5	-0.0076	-0.0130	-0.0998	-0.0084	0.1381	-0.0259
1487	6	20	10	-0.0067	0.0039	-0.1061	0.0008	0.1281	-0.0102
1491	6	20	15	-0.0069	0.0251	-0.1134	0.0104	0.1262	0.0077

* Indicates model was close to heave stop

TABLE 8.304.1 - NON-DIMENSIONAL STABILITY DATA IN BODY AXES AT TRANSOM

30 deg Deadrise, L/R = 0.000, Cv = 4

RUN	Trim deg	Roll deg	Yaw deg	X'	Y'	Z'	K'	M'	N'
1644 *	-2	-10	0	-0.0550	0.0179	-0.0506	0.0126	0.1286	0.0615
1592 *	-2	0	0	-0.0533	-0.0040	-0.0532	-0.0011	0.1238	-0.0191
1596 *	-2	0	5	-0.0578	0.0566	-0.0530	0.0252	0.1394	0.2711
1617 *	-2	10	0	-0.0553	-0.0223	-0.0498	-0.0137	0.1261	-0.0911
1631 *	-2	20	0	-0.0537	-0.0324	-0.0444	-0.0205	0.1143	-0.1434
1574	0	-10	0	-0.0271	0.0096	-0.0538	0.0049	0.1786	0.0383
1578	0	-10	5	-0.0389	0.0482	-0.0472	0.0218	0.1648	0.1731
1582	0	-10	10	-0.0373	0.1082	-0.0366	0.0477	0.1281	0.3576
1586	0	-10	15	-0.0096	0.0374	-0.0489	0.0175	0.1215	0.1007
1515	0	0	0	-0.0258	-0.0004	-0.0547	0.0000	0.1888	-0.0011
1531	0	0	5	-0.0354	0.0350	-0.0547	0.0162	0.2067	0.1304
1542	0	10	0	-0.0269	-0.0089	-0.0541	-0.0044	0.1763	-0.0349
1546	0	10	5	-0.0330	0.0251	-0.0601	0.0115	0.2346	0.0955
1556	0	20	0	-0.0303	-0.0181	-0.0514	-0.0095	0.1558	-0.0578
1560	0	20	5	-0.0327	0.0151	-0.0637	0.0059	0.2414	0.0516
1564	0	20	10	-0.0417	0.0794	-0.0873	0.0344	0.3625	0.2494
1568	0	20	15	-0.0549	0.1799	-0.1244	0.0819	0.5335	0.5236
1377	3	-10	0	-0.0141	0.0124	-0.0532	0.0079	0.1184	0.0323
1381	3	-10	5	-0.0151	0.0320	-0.0500	0.0175	0.1229	0.0775
1385	3	-10	10	-0.0191	0.0794	-0.0420	0.0403	0.1357	0.1703
1389	3	-10	15	-0.0058	0.0446	-0.0473	0.0241	0.0546	0.0504
1306	3	0	0	-0.0137	0.0005	-0.0551	0.0007	0.1154	0.0016
1312	3	0	5	-0.0151	0.0249	-0.0550	0.0127	0.1219	0.0576
1317	3	0	10	-0.0210	0.0796	-0.0577	0.0381	0.1592	0.1754
1322	3	0	10	-0.0207	0.0772	-0.0554	0.0374	0.1545	0.1711
1321	3	0	15	-0.0312	0.2074	-0.0565	0.1004	0.2479	0.4715

* Indicates model was close to heave stop

TABLE 8.304.2 - NON-DIMENSIONAL STABILITY DATA IN BODY AXES AT TRANSOM

30 deg Deadrise, L/R = 0.000, Cv = 4

RUN	Trim deg	Roll deg	Yaw deg	X'	Y'	Z'	K'	M'	N'
1327	3	10	0	-0.0143	-0.0112	-0.0540	-0.0067	0.1199	-0.0286
1331	3	10	5	-0.0141	0.0116	-0.0580	0.0050	0.1172	0.0208
1335	3	10	10	-0.0169	0.0522	-0.0655	0.0236	0.1419	0.1043
1339	3	10	15	-0.0266	0.1554	-0.0844	0.0718	0.2660	0.3547
1340	3	10	15	-0.0266	0.1546	-0.0841	0.0717	0.2658	0.3536
1345	3	20	0	-0.0135	-0.0195	-0.0513	-0.0116	0.1209	-0.0509
1362	3	20	5	-0.0123	-0.0055	-0.0562	-0.0046	0.1150	-0.0198
1366	3	20	10	-0.0136	0.0183	-0.0651	0.0058	0.1185	0.0201
1372	3	20	15	-0.0155	0.0591	-0.0799	0.0216	0.1396	0.0840
1497	6	-10	0	-0.0057	0.0129	-0.0537	0.0089	0.0595	0.0143
1501	6	-10	5	-0.0066	0.0281	-0.0514	0.0169	0.0641	0.0299
1505	6	-10	10	-0.0072	0.0471	-0.0483	0.0256	0.0634	0.0493
1509	6	-10	15	-0.0109	0.0915	-0.0408	0.0469	0.0684	0.0950
1408	6	0	0	-0.0051	-0.0011	-0.0549	0.0008	0.0557	-0.0018
1412	6	0	5	-0.0063	0.0170	-0.0549	0.0099	0.0568	0.0135
1439	6	0	5	-0.0060	0.0164	-0.0547	0.0099	0.0543	0.0115
1443	6	0	10	-0.0067	0.0386	-0.0555	0.0204	0.0590	0.0338
1458	6	0	15	-0.0086	0.0708	-0.0557	0.0347	0.0645	0.0704
1463	6	10	0	-0.0056	-0.0144	-0.0537	-0.0071	0.0566	-0.0181
1467	6	10	5	-0.0056	0.0030	-0.0569	0.0012	0.0564	-0.0008
1471	6	10	10	-0.0064	0.0218	-0.0603	0.0103	0.0572	0.0134
1475	6	10	15	-0.0070	0.0487	-0.0651	0.0217	0.0615	0.0374
1480	6	20	0	-0.0056	-0.0223	-0.0506	-0.0124	0.0606	-0.0264
1484	6	20	5	-0.0040	-0.0118	-0.0544	-0.0071	0.0546	-0.0154
1488	6	20	10	-0.0043	-0.0012	-0.0584	-0.0024	0.0518	-0.0084
1492	6	20	15	-0.0047	0.0124	-0.0633	0.0030	0.0533	0.0002

* Indicates model was close to heave stop

TABLE 8.311.1 - NON-DIMENSIONAL STABILITY DATA IN BODY AXES AT TRANSOM

30 deg Deadrise, L/R = 0.117, Cv = 1.5

RUN	Trim deg	Roll deg	Yaw deg	X'	Y'	Z'	K'	M'	N'
564 *	0	-10	-15	-0.0717	-0.2076	-0.4333	-0.0734	1.2993	-0.8427
561	0	-10	-10	-0.0546	-0.0389	-0.4024	0.0033	1.1179	-0.2636
556	0	-10	-5	-0.0445	0.0345	-0.3884	0.0325	1.0346	0.0013
528	0	-10	0	-0.0393	0.0717	-0.3819	0.0442	1.0040	0.1599
532	0	-10	5	-0.0426	0.1014	-0.3766	0.0556	1.0037	0.2781
536	0	-10	10	-0.0501	0.1626	-0.3658	0.0811	1.0008	0.4839
550	0	-10	15	-0.0619	0.2693	-0.3460	0.1226	1.0006	0.8526
464 *	0	0	-15	-0.0683	-0.2950	-0.3906	-0.1313	1.0864	-1.0907
461	0	0	-10	-0.0559	-0.1207	-0.3896	-0.0480	1.0629	-0.4875
457	0	0	-5	-0.0484	-0.0388	-0.3896	-0.0148	1.0374	-0.1971
78	0	0	0	-0.0402	0.0018	-0.3875	0.0011	1.0185	-0.0303
443	0	0	0	-0.0436	-0.0002	-0.3875	0.0011	1.0232	-0.0363
448	0	0	5	-0.0435	0.0353	-0.3875	0.0170	1.0441	0.0986
452	0	0	10	-0.0518	0.1000	-0.3885	0.0441	1.0956	0.3003
455 *	0	0	15	-0.0746	0.2596	-0.3885	0.1168	1.1995	0.7840
496	0	10	-15	-0.0618	-0.3084	-0.3412	-0.1353	0.9136	-1.1244
492	0	10	-10	-0.0534	-0.1838	-0.3621	-0.0834	0.9542	-0.6588
488	0	10	-5	-0.0471	-0.1073	-0.3745	-0.0531	0.9754	-0.3745
467	0	10	0	-0.0418	-0.0656	-0.3840	-0.0376	1.0022	-0.2104
479	0	10	5	-0.0415	-0.0375	-0.3868	-0.0283	1.0360	-0.0966
483	0	10	10	-0.0506	0.0225	-0.3996	-0.0075	1.1302	0.0937
486 *	0	10	15	-0.0692	0.1546	-0.4218	0.0499	1.3166	0.4669
523	0	20	-15	-0.0716	-0.3568	-0.2825	-0.1563	0.7606	-1.2719
519	0	20	-10	-0.0545	-0.2280	-0.3305	-0.1092	0.8477	-0.7668
515	0	20	-5	-0.0489	-0.1659	-0.3531	-0.0861	0.9057	-0.5269
501	0	20	0	-0.0418	-0.1353	-0.3620	-0.0773	0.9266	-0.3877
505	0	20	5	-0.0412	-0.1060	-0.3737	-0.0675	0.9877	-0.2828
509	0	20	10	-0.0484	-0.0567	-0.3928	-0.0539	1.1053	-0.1302
513	0	20	15	-0.0675	0.0593	-0.4350	-0.0071	1.3639	0.1998
276	3	-10	-15	-0.0325	-0.0819	-0.4123	-0.0188	0.9236	-0.2498
272	3	-10	-10	-0.0256	-0.0008	-0.3976	0.0193	0.8113	-0.0655
267	3	-10	-5	-0.0225	0.0527	-0.3891	0.0412	0.7622	0.0719
246	3	-10	0	-0.0192	0.0840	-0.3802	0.0541	0.7406	0.1577
249	3	-10	5	-0.0219	0.1187	-0.3753	0.0695	0.7522	0.2438
251	3	-10	5	-0.0216	0.1184	-0.3753	0.0693	0.7523	0.2425
253	3	-10	5	-0.0212	0.1190	-0.3752	0.0696	0.7531	0.2444
257	3	-10	10	-0.0284	0.1919	-0.3627	0.1005	0.7756	0.4095
261	3	-10	15	-0.0343	0.2972	-0.3445	0.1471	0.7699	0.6649
129	3	0	-15	-0.0335	-0.2177	-0.3919	-0.0990	0.8480	-0.6027
124	3	0	-10	-0.0263	-0.0870	-0.3904	-0.0350	0.7816	-0.2629
120	3	0	-5	-0.0224	-0.0231	-0.3892	-0.0061	0.7522	-0.0944
81	3	0	0	-0.0214	0.0109	-0.3912	0.0097	0.7509	0.0033
87	3	0	5	-0.0149	0.0127	-0.3909	0.0110	0.7478	0.0072
107	3	0	5	-0.0223	0.0490	-0.3913	0.0293	0.7698	0.1029
111	3	0	10	-0.0276	0.1171	-0.3926	0.0584	0.8169	0.2558
115	3	0	15	-0.0361	0.2456	-0.3920	0.1169	0.8999	0.5387
135	3	0	15	-0.0385	0.2530	-0.3921	0.1207	0.9049	0.5605

* Indicates model was close to heave stop

TABLE 8.311.2 - NON-DIMENSIONAL STABILITY DATA IN BODY AXES AT TRANSOM

30 deg Deadrise, L/R = 0.117, Cv = 1.5

RUN	Trim deg	Roll deg	Yaw deg	X'	Y'	Z'	K'	M'	N'
188	3	10	-15	-0.0321	-0.1952	-0.3623	-0.0943	0.8431	-0.4753
184	3	10	-10	-0.0314	-0.1559	-0.3692	-0.0774	0.7701	-0.3934
180	3	10	-5	-0.0278	-0.0891	-0.3808	-0.0480	0.7652	-0.2211
138	3	10	0	-0.0223	-0.0552	-0.3865	-0.0327	0.7610	-0.1290
144	3	10	5	-0.0209	-0.0264	-0.3915	-0.0202	0.7729	-0.0606
146	3	10	5	-0.0209	-0.0248	-0.3918	-0.0190	0.7737	-0.0564
150	3	10	10	-0.0240	0.0320	-0.4020	0.0046	0.8304	0.0695
170	3	10	15	-0.0336	0.1455	-0.4225	0.0556	0.9526	0.3138
173	3	10	15	-0.0336	0.1468	-0.4227	0.0566	0.9530	0.3186
174	3	10	15	-0.0341	0.1487	-0.4242	0.0574	0.9570	0.3235
240	3	20	-15	-0.0359	-0.2343	-0.3330	-0.1132	0.8053	-0.5544
235	3	20	-10	-0.0271	-0.1987	-0.3466	-0.1017	0.7178	-0.4566
231	3	20	-5	-0.0255	-0.1557	-0.3599	-0.0845	0.7121	-0.3465
197	3	20	0	-0.0206	-0.1222	-0.3696	-0.0702	0.7175	-0.2595
204	3	20	5	-0.0198	-0.0956	-0.3895	-0.0608	0.7663	-0.2009
210	3	20	10	-0.0238	-0.0445	-0.4048	-0.0416	0.8304	-0.1019
214	3	20	15	-0.0315	0.0518	-0.4369	-0.0033	0.9934	0.0830
437	6	-10	-15	-0.0180	-0.0525	-0.4089	-0.0111	0.6878	-0.0623
433	6	-10	-10	-0.0156	0.0014	-0.3981	0.0128	0.6175	0.0023
429	6	-10	-5	-0.0134	0.0471	-0.3898	0.0365	0.5897	0.0715
404	6	-10	0	-0.0130	0.0904	-0.3832	0.0586	0.5903	0.1445
408	6	-10	5	-0.0155	0.1336	-0.3737	0.0797	0.5878	0.2120
412	6	-10	10	-0.0196	0.2096	-0.3618	0.1130	0.6048	0.3354
425	6	-10	15	-0.0234	0.3299	-0.3399	0.1691	0.6224	0.5290
325	6	0	-15	-0.0187	-0.1625	-0.3926	-0.0707	0.6569	-0.2808
318	6	0	-10	-0.0152	-0.0749	-0.3923	-0.0316	0.6138	-0.1328
312	6	0	-5	-0.0134	-0.0224	-0.3910	-0.0072	0.5832	-0.0435
290	6	0	0	-0.0072	0.0202	-0.3893	0.0157	0.5796	0.0310
294	6	0	5	-0.0126	0.0636	-0.3920	0.0381	0.5950	0.0996
299	6	0	10	-0.0180	0.1314	-0.3925	0.0690	0.6289	0.2079
303	6	0	15	-0.0202	0.2400	-0.3928	0.1168	0.6851	0.3842
309	6	0	15	-0.0207	0.2436	-0.3918	0.1183	0.6823	0.3910
365	6	10	-15	-0.0194	-0.2413	-0.3573	-0.1189	0.6185	-0.4122
360	6	10	-10	-0.0156	-0.1485	-0.3722	-0.0746	0.5876	-0.2549
347	6	10	-5	-0.0151	-0.0921	-0.3821	-0.0494	0.5759	-0.1570
330	6	10	0	-0.0123	-0.0521	-0.3888	-0.0287	0.5745	-0.0899
335	6	10	5	-0.0118	-0.0066	-0.3957	-0.0051	0.5933	-0.0151
339	6	10	10	-0.0159	0.0524	-0.4065	0.0233	0.6360	0.0746
343	6	10	15	-0.0201	0.1489	-0.4240	0.0653	0.7173	0.2249
398	6	20	-15	-0.0183	-0.2812	-0.3166	-0.1419	0.5754	-0.4681
394	6	20	-10	-0.0166	-0.2193	-0.3389	-0.1141	0.5423	-0.3585
390	6	20	-5	-0.0141	-0.1589	-0.3606	-0.0873	0.5550	-0.2558
373	6	20	0	-0.0130	-0.1149	-0.3765	-0.0672	0.5713	-0.1829
377	6	20	5	-0.0123	-0.0709	-0.3924	-0.0462	0.6031	-0.1241
382	6	20	10	-0.0145	-0.0114	-0.4121	-0.0156	0.6653	-0.0513
386	6	20	15	-0.0169	0.0503	-0.4371	0.0127	0.7371	0.0354

* Indicates model was close to heave stop

TABLE 8.313.1 - NON-DIMENSIONAL STABILITY DATA IN BODY AXES AT TRANSOM

30 deg Deadrise, L/R = 0.117, Cv = 3

RUN	Trim deg	Roll deg	Yaw deg	X'	Y'	Z'	K'	M'	N'
562 *	0	-10	-10	-0.0544	-0.1447	-0.1240	-0.0579	0.3674	-0.5660
558	0	-10	-5	-0.0338	-0.0255	-0.1030	-0.0073	0.3257	-0.1357
529	0	-10	0	-0.0265	0.0149	-0.0960	0.0097	0.2745	0.0229
533	0	-10	5	-0.0333	0.0518	-0.0894	0.0254	0.2719	0.1414
537	0	-10	10	-0.0460	0.1421	-0.0736	0.0644	0.2450	0.3936
552	0	-10	15	-0.0270	0.1255	-0.0765	0.0614	0.2202	0.3533
462 *	0	0	-10	-0.0515	-0.1655	-0.0974	-0.0731	0.2888	-0.6165
458	0	0	-5	-0.0350	-0.0413	-0.0973	-0.0173	0.2834	-0.1809
444	0	0	0	-0.0280	-0.0016	-0.0971	0.0000	0.2856	-0.0337
449	0	0	5	-0.0322	0.0348	-0.0969	0.0172	0.3085	0.0916
453 *	0	0	10	-0.0600	0.1612	-0.0969	0.0716	0.3332	0.4361
497	0	10	-15	-0.0196	-0.0670	-0.0870	-0.0384	0.3116	-0.2308
493	0	10	-10	-0.0404	-0.1441	-0.0731	-0.0622	0.2100	-0.5282
489	0	10	-5	-0.0343	-0.0590	-0.0881	-0.0260	0.2469	-0.2218
468	0	10	0	-0.0309	-0.0174	-0.0957	-0.0093	0.2656	-0.0728
480	0	10	5	-0.0320	0.0192	-0.1019	0.0078	0.3203	0.0453
484	0	10	10	-0.0466	0.1096	-0.1179	0.0478	0.3932	0.2899
524	0	20	-15	-0.0342	-0.1205	-0.0594	-0.0545	0.2907	-0.4187
520	0	20	-10	-0.0439	-0.1135	-0.0621	-0.0529	0.2756	-0.4353
516	0	20	-5	-0.0337	-0.0741	-0.0764	-0.0342	0.2091	-0.2613
502	0	20	0	-0.0296	-0.0372	-0.0894	-0.0203	0.2431	-0.1258
506	0	20	5	-0.0310	-0.0038	-0.1017	-0.0064	0.2972	-0.0201
510	0	20	10	-0.0421	0.0710	-0.1291	0.0276	0.4223	0.2021
277	3	-10	-15	-0.0218	-0.1409	-0.1249	-0.0605	0.3419	-0.3732
273	3	-10	-10	-0.0173	-0.0480	-0.1082	-0.0169	0.2435	-0.1359
269	3	-10	-5	-0.0159	-0.0005	-0.0996	0.0042	0.2114	-0.0168
247	3	-10	0	-0.0145	0.0279	-0.0946	0.0178	0.2003	0.0535
254	3	-10	5	-0.0178	0.0574	-0.0896	0.0315	0.2041	0.1181
258	3	-10	10	-0.0223	0.1242	-0.0782	0.0621	0.2227	0.2456
262	3	-10	15	-0.0092	0.0817	-0.0844	0.0451	0.1197	0.1227
130	3	0	-15	-0.0253	-0.2043	-0.0994	-0.0978	0.3121	-0.5358
125	3	0	-10	-0.0194	-0.0772	-0.0987	-0.0347	0.2385	-0.2140
121	3	0	-5	-0.0175	-0.0226	-0.0984	-0.0095	0.2070	-0.0771
82	3	0	0	-0.0153	0.0078	-0.0990	0.0056	0.2007	0.0038
88	3	0	5	-0.0089	0.0074	-0.0981	0.0053	0.1932	0.0029
101	3	0	5	-0.0173	0.0451	-0.0986	0.0241	0.2079	0.0777
105	3	0	5	-0.0172	0.0402	-0.0991	0.0217	0.2138	0.0789
112	3	0	10	-0.0238	0.1080	-0.0993	0.0530	0.2562	0.2185
116	3	0	15	-0.0330	0.2539	-0.0998	0.1223	0.3554	0.5411
132	3	0	15	-0.0364	0.2698	-0.1001	0.1298	0.3690	0.5886

* Indicates model was close to heave stop

TABLE 8.313.2 - NON-DIMENSIONAL STABILITY DATA IN BODY AXES AT TRANSON

30 deg Deadrise, L/R = 0.117, Cv = 3

RUN	Trim deg	Roll deg	Yaw deg	X'	Y'	Z'	K'	M'	N'
191	3	10	-15	-0.0089	-0.0644	-0.0880	-0.0342	0.1702	-0.1227
185	3	10	-10	-0.0193	-0.0919	-0.0837	-0.0451	0.2208	-0.2325
181	3	10	-5	-0.0170	-0.0403	-0.0928	-0.0208	0.2075	-0.1132
141	3	10	0	-0.0157	-0.0113	-0.0984	-0.0068	0.2024	-0.0432
147	3	10	5	-0.0144	0.0172	-0.1030	0.0080	0.2118	0.0210
151	3	10	10	-0.0183	0.0665	-0.1120	0.0310	0.2543	0.1245
175	3	10	15	-0.0284	0.1852	-0.1336	0.0865	0.3892	0.3722
241	3	20	-15	-0.0098	-0.0733	-0.0777	-0.0398	0.1764	-0.1326
236	3	20	-10	-0.0151	-0.0712	-0.0780	-0.0375	0.1987	-0.1634
232	3	20	-5	-0.0171	-0.0535	-0.0850	-0.0286	0.1920	-0.1305
200	3	20	0	-0.0153	-0.0254	-0.0954	-0.0159	0.2037	-0.0746
206	3	20	5	-0.0135	-0.0030	-0.1043	-0.0045	0.2134	-0.0301
211	3	20	10	-0.0145	0.0294	-0.1150	0.0098	0.2295	0.0262
215	3	20	15	-0.0155	0.0826	-0.1311	0.0318	0.2620	0.1175
216	3	20	15	-0.0160	0.0838	-0.1348	0.0324	0.2731	0.1206
438	6	-10	-15	-0.0067	-0.0537	-0.1092	-0.0222	0.1468	-0.0643
434	6	-10	-10	-0.0068	-0.0189	-0.1034	-0.0062	0.1370	-0.0204
430	6	-10	-5	-0.0063	0.0063	-0.0989	0.0064	0.1370	0.0119
405	6	-10	0	-0.0074	0.0297	-0.0951	0.0190	0.1455	0.0475
409	6	-10	5	-0.0113	0.0619	-0.0893	0.0351	0.1498	0.0894
413	6	-10	10	-0.0123	0.1065	-0.0816	0.0551	0.1529	0.1451
426	6	-10	15	-0.0140	0.1847	-0.0681	0.0915	0.1689	0.2538
326	6	0	-15	-0.0101	-0.0967	-0.0986	-0.0445	0.1716	-0.1541
319	6	0	-10	-0.0086	-0.0437	-0.0982	-0.0207	0.1474	-0.0687
315	6	0	-5	-0.0084	-0.0135	-0.0983	-0.0054	0.1365	-0.0227
292	6	0	0	-0.0074	0.0123	-0.0979	0.0084	0.1355	0.0151
296	6	0	5	-0.0088	0.0390	-0.0983	0.0225	0.1438	0.0539
300	6	0	10	-0.0115	0.0802	-0.0986	0.0425	0.1589	0.1091
304	6	0	15	-0.0138	0.1544	-0.0994	0.0761	0.1939	0.2118
366	6	10	-15	-0.0122	-0.1291	-0.0777	-0.0630	0.1598	-0.2011
361	6	10	-10	-0.0105	-0.0610	-0.0879	-0.0307	0.1505	-0.0976
363	6	10	-10	-0.0103	-0.0631	-0.0894	-0.0319	0.1529	-0.1019
357	6	10	-5	-0.0089	-0.0294	-0.0944	-0.0159	0.1432	-0.0533
331	6	10	0	-0.0070	-0.0070	-0.0986	-0.0035	0.1349	-0.0170
336	6	10	5	-0.0071	0.0183	-0.1028	0.0098	0.1324	0.0171
340	6	10	10	-0.0089	0.0495	-0.1086	0.0252	0.1383	0.0545
344	6	10	15	-0.0099	0.0957	-0.1168	0.0459	0.1603	0.1152
400	6	20	-15	-0.0090	-0.1131	-0.0639	-0.0567	0.1176	-0.1487
395	6	20	-10	-0.0094	-0.0798	-0.0766	-0.0412	0.1376	-0.1173
391	6	20	-5	-0.0097	-0.0437	-0.0894	-0.0248	0.1463	-0.0734
374	6	20	0	-0.0077	-0.0225	-0.0962	-0.0135	0.1423	-0.0420
378	6	20	5	-0.0059	-0.0045	-0.1030	-0.0041	0.1334	-0.0170
383	6	20	10	-0.0060	0.0162	-0.1101	0.0057	0.1294	0.0060
387	6	20	15	-0.0068	0.0414	-0.1201	0.0163	0.1330	0.0304

* Indicates model was close to heave stop

TABLE 8.314.1 - NON-DIMENSIONAL STABILITY DATA IN BODY AXES AT TRANSOM

30 deg Deadrise, L/R = 0.117, Cv = 4

RUN	Trim deg	Roll deg	Yaw deg	X'	Y'	Z'	K'	M'	N'
559	0	-10	-5	-0.0324	-0.0313	-0.0614	-0.0121	0.2381	-0.1526
530	0	-10	0	-0.0257	0.0069	-0.0542	0.0042	0.1847	0.0035
534	0	-10	5	-0.0384	0.0507	-0.0466	0.0235	0.1812	0.1291
554 *	0	-10	10	-0.0491	0.1471	-0.0298	0.0669	0.1121	0.4401
553	0	-10	15	-0.0086	0.0419	-0.0483	0.0211	0.1096	0.1091
459	0	0	-5	-0.0361	-0.0371	-0.0549	-0.0146	0.1928	-0.1770
445	0	0	0	-0.0254	-0.0023	-0.0547	-0.0005	0.1860	-0.0358
450	0	0	5	-0.0327	0.0362	-0.0546	0.0176	0.2105	0.0914
498	0	10	-15	-0.0093	-0.0386	-0.0485	-0.0185	0.1349	-0.1122
494	0	10	-10	-0.0376	-0.1289	-0.0328	-0.0550	0.0974	-0.4948
490	0	10	-5	-0.0347	-0.0487	-0.0469	-0.0199	0.1520	-0.2124
469	0	10	0	-0.0305	-0.0088	-0.0541	-0.0042	0.1662	-0.0523
481	0	10	5	-0.0326	0.0287	-0.0607	0.0144	0.2296	0.0697
525	0	20	-15	-0.0181	-0.0585	-0.0370	-0.0274	0.1572	-0.1781
521	0	20	-10	-0.0370	-0.0850	-0.0272	-0.0402	0.1923	-0.3459
517	0	20	-5	-0.0330	-0.0580	-0.0373	-0.0250	0.1177	-0.2344
503	0	20	0	-0.0300	-0.0206	-0.0505	-0.0105	0.1485	-0.0889
507	0	20	5	-0.0317	0.0154	-0.0636	0.0059	0.2089	0.0316
278	3	-10	-15	-0.0199	-0.1431	-0.0821	-0.0636	0.2531	-0.3772
274	3	-10	-10	-0.0149	-0.0474	-0.0650	-0.0181	0.1453	-0.1206
270	3	-10	-5	-0.0135	-0.0032	-0.0570	0.0011	0.1205	-0.0160
248	3	-10	0	-0.0136	0.0202	-0.0528	0.0125	0.1236	0.0391
255	3	-10	5	-0.0158	0.0451	-0.0487	0.0240	0.1213	0.0885
259	3	-10	10	-0.0178	0.0933	-0.0400	0.0467	0.1325	0.1751
265	3	-10	15	-0.0048	0.0501	-0.0471	0.0261	0.0448	0.0570
131	3	0	-15	-0.0238	-0.1994	-0.0564	-0.0968	0.2307	-0.5204
126	3	0	-10	-0.0175	-0.0692	-0.0558	-0.0316	0.1522	-0.1900
122	3	0	-5	-0.0140	-0.0185	-0.0556	-0.0079	0.1202	-0.0571
83	3	0	0	-0.0137	0.0077	-0.0557	0.0051	0.1156	0.0057
106	3	0	5	-0.0149	0.0361	-0.0558	0.0193	0.1246	0.0664
113	3	0	10	-0.0191	0.0900	-0.0561	0.0443	0.1538	0.1688
117	3	0	15	-0.0309	0.2510	-0.0567	0.1215	0.2732	0.5330
133	3	0	15	-0.0376	0.2898	-0.0569	0.1393	0.3063	0.6493

* Indicates model was close to heave stop

TABLE 8.314.2 - NON-DIMENSIONAL STABILITY DATA IN BODY AXES AT TRANSOM

30 deg Deadrise, L/R = 0.117, Cv = 4

RUN	Trim deg	Roll deg	Yaw deg	X'	Y'	Z'	K'	M'	N'
192	3	10	-15	-0.0066	-0.0478	-0.0474	-0.0239	0.0642	-0.0715
193	3	10	-15	-0.0064	-0.0492	-0.0472	-0.0243	0.0688	-0.0735
186	3	10	-10	-0.0132	-0.0601	-0.0458	-0.0292	0.1264	-0.1398
182	3	10	-5	-0.0125	-0.0252	-0.0519	-0.0128	0.1212	-0.0702
143	3	10	0	-0.0128	-0.0045	-0.0557	-0.0024	0.1142	-0.0234
148	3	10	5	-0.0131	0.0209	-0.0602	0.0105	0.1150	0.0270
153	3	10	10	-0.0149	0.0631	-0.0677	0.0298	0.1402	0.1062
178	3	10	15	-0.0245	0.1715	-0.0872	0.0814	0.2697	0.3392
243	3	20	-15	-0.0056	-0.0361	-0.0456	-0.0203	0.0656	-0.0447
238	3	20	-10	-0.0091	-0.0371	-0.0454	-0.0209	0.0995	-0.0698
233	3	20	-5	-0.0139	-0.0319	-0.0480	-0.0175	0.1193	-0.0824
201	3	20	0	-0.0113	-0.0137	-0.0533	-0.0090	0.1156	-0.0421
202	3	20	0	-0.0113	-0.0135	-0.0535	-0.0089	0.1159	-0.0412
207	3	20	5	-0.0107	0.0042	-0.0602	0.0001	0.1125	-0.0065
212	3	20	10	-0.0120	0.0293	-0.0697	0.0105	0.1197	0.0316
229	3	20	15	-0.0132	0.0720	-0.0855	0.0270	0.1427	0.0951
439	6	-10	-15	-0.0046	-0.0343	-0.0622	-0.0127	0.0599	-0.0280
435	6	-10	-10	-0.0045	-0.0120	-0.0583	-0.0030	0.0571	-0.0082
431	6	-10	-5	-0.0031	0.0064	-0.0550	0.0057	0.0550	0.0098
406	6	-10	0	-0.0055	0.0230	-0.0524	0.0140	0.0590	0.0277
410	6	-10	5	-0.0065	0.0398	-0.0492	0.0225	0.0639	0.0476
414	6	-10	10	-0.0067	0.0601	-0.0459	0.0317	0.0561	0.0604
427	6	-10	15	-0.0064	0.0857	-0.0414	0.0433	0.0549	0.0830
327	6	0	-15	-0.0063	-0.0609	-0.0558	-0.0281	0.0621	-0.0680
322	6	0	-10	-0.0057	-0.0297	-0.0557	-0.0139	0.0569	-0.0293
316	6	0	-5	-0.0059	-0.0088	-0.0555	-0.0034	0.0535	-0.0083
293	6	0	0	-0.0056	0.0110	-0.0555	0.0069	0.0545	0.0115
297	6	0	5	-0.0062	0.0308	-0.0556	0.0170	0.0569	0.0310
301	6	0	10	-0.0063	0.0534	-0.0556	0.0275	0.0574	0.0520
306	6	0	15	-0.0062	0.0818	-0.0555	0.0397	0.0579	0.0808
368	6	10	-15	-0.0086	-0.0780	-0.0430	-0.0383	0.0682	-0.0946
362	6	10	-10	-0.0055	-0.0371	-0.0500	-0.0192	0.0645	-0.0424
358	6	10	-5	-0.0051	-0.0195	-0.0529	-0.0102	0.0603	-0.0209
333	6	10	0	-0.0042	-0.0044	-0.0555	-0.0025	0.0547	-0.0055
337	6	10	5	-0.0053	0.0144	-0.0588	0.0067	0.0550	0.0132
341	6	10	10	-0.0063	0.0369	-0.0628	0.0173	0.0564	0.0332
345	6	10	15	-0.0065	0.0664	-0.0680	0.0299	0.0605	0.0596
370	6	10	15	-0.0067	0.0670	-0.0684	0.0303	0.0610	0.0595
401	6	20	-15	-0.0052	-0.0611	-0.0371	-0.0313	0.0544	-0.0574
396	6	20	-10	-0.0067	-0.0458	-0.0429	-0.0243	0.0633	-0.0510
392	6	20	-5	-0.0053	-0.0259	-0.0498	-0.0149	0.0679	-0.0331
375	6	20	0	-0.0047	-0.0155	-0.0532	-0.0092	0.0581	-0.0179
379	6	20	5	-0.0037	-0.0042	-0.0574	-0.0039	0.0527	-0.0053
380	6	20	5	-0.0036	-0.0042	-0.0573	-0.0039	0.0523	-0.0056
384	6	20	10	-0.0039	0.0083	-0.0620	0.0014	0.0526	0.0047
388	6	20	15	-0.0047	0.0259	-0.0686	0.0083	0.0547	0.0189

* Indicates model was close to heave stop

TABLE 8.321.1 - NON-DIMENSIONAL STABILITY DATA IN BODY AXES AT TRANSOM

30 deg Deadrise, L/R = 0.234, Cv = 1.5

RUN	Trim deg	Roll deg	Yaw deg	X'	Y'	Z'	K'	M'	N'
1127	0	-10	-15	-0.0598	-0.1870	-0.4296	-0.0636	1.2080	-0.8128
1129 *	0	-10	-15	-0.0634	-0.2065	-0.4320	-0.0721	1.2260	-0.9055
1123	0	-10	-10	-0.0484	-0.0481	-0.4041	-0.0014	1.0842	-0.3294
1118	0	-10	-5	-0.0400	0.0238	-0.3914	0.0267	1.0155	-0.0582
1102	0	-10	0	-0.0385	0.0635	-0.3844	0.0401	1.0046	0.1115
1106	0	-10	5	-0.0400	0.0945	-0.3789	0.0530	1.0178	0.2263
1111	0	-10	10	-0.0506	0.1568	-0.3679	0.0791	1.0378	0.4141
1114	0	-10	15	-0.0591	0.2332	-0.3545	0.1085	1.0143	0.6878
1025	0	0	-15	-0.0560	-0.2910	-0.3906	-0.1319	1.0400	-1.1134
1021	0	0	-10	-0.0481	-0.1325	-0.3906	-0.0534	1.0370	-0.5523
1017	0	0	-5	-0.0435	-0.0481	-0.3906	-0.0173	1.0153	-0.2519
1004	0	0	0	-0.0394	-0.0021	-0.3885	0.0008	1.0203	-0.0725
1008	0	0	5	-0.0423	0.0310	-0.3885	0.0151	1.0550	0.0491
1012	0	0	10	-0.0520	0.0929	-0.3896	0.0410	1.1247	0.2276
1015 *	0	0	15	-0.0743	0.2525	-0.3906	0.1142	1.2566	0.6655
1059	0	10	-15	-0.0722	-0.2810	-0.3460	-0.1210	0.9692	-1.0404
1055	0	10	-10	-0.0488	-0.1929	-0.3626	-0.0867	0.9371	-0.7064
1051	0	10	-5	-0.0454	-0.1185	-0.3747	-0.0570	0.9623	-0.4345
1036	0	10	0	-0.0414	-0.0742	-0.3814	-0.0401	0.9918	-0.2621
1040	0	10	5	-0.0427	-0.0418	-0.3882	-0.0311	1.0412	-0.1473
1044	0	10	10	-0.0512	0.0135	-0.3990	-0.0105	1.1424	0.0099
1045	0	10	10	-0.0521	0.0205	-0.3981	-0.0090	1.1436	0.0278
1049	0	10	15	-0.0723	0.1513	-0.4223	0.0495	1.3497	0.3675
1097	0	20	-15	-0.0762	-0.3292	-0.2936	-0.1468	0.7668	-1.1488
1093	0	20	-10	-0.0535	-0.2252	-0.3326	-0.1075	0.8236	-0.7453
1088	0	20	-5	-0.0447	-0.1755	-0.3496	-0.0886	0.8706	-0.5574
1064	0	20	0	-0.0422	-0.1400	-0.3636	-0.0773	0.9248	-0.4253
1068	0	20	5	-0.0431	-0.1098	-0.3724	-0.0691	0.9865	-0.3256
1071	0	20	10	-0.0506	-0.0634	-0.3915	-0.0573	1.1097	-0.2018
1073	0	20	10	-0.0506	-0.0583	-0.3933	-0.0554	1.1166	-0.1909
1077	0	20	15	-0.0672	0.0474	-0.4330	-0.0144	1.3528	0.0844
833	3	-10	-15	-0.0240	-0.0990	-0.4138	-0.0227	0.8678	-0.3638
829	3	-10	-10	-0.0218	-0.0050	-0.3982	0.0188	0.7807	-0.1116
825	3	-10	-5	-0.0196	0.0547	-0.3865	0.0431	0.7417	0.0541
801	3	-10	0	-0.0197	0.0885	-0.3816	0.0572	0.7427	0.1442
813	3	-10	5	-0.0211	0.1302	-0.3721	0.0745	0.7597	0.2394
817	3	-10	10	-0.0280	0.2090	-0.3576	0.1070	0.7984	0.4021
821	3	-10	15	-0.0399	0.3483	-0.3347	0.1729	0.8340	0.6999
698	3	0	-15	-0.0284	-0.2031	-0.3916	-0.0891	0.8121	-0.6202
689	3	0	-10	-0.0184	-0.0782	-0.3911	-0.0287	0.7689	-0.2587
700	3	0	-10	-0.0232	-0.0816	-0.3913	-0.0291	0.7667	-0.2807
685	3	0	-5	-0.0193	-0.0206	-0.3922	-0.0019	0.7501	-0.1102
705	3	0	-5	-0.0213	-0.0259	-0.3912	-0.0053	0.7461	-0.1243
658	3	0	0	-0.0194	0.0162	-0.3911	0.0148	0.7514	-0.0068
711	3	0	0	-0.0204	0.0172	-0.3912	0.0149	0.7538	-0.0056
662	3	0	5	-0.0204	0.0538	-0.3922	0.0321	0.7763	0.0810
713	3	0	5	-0.0199	0.0558	-0.3912	0.0329	0.7753	0.0864
676	3	0	10	-0.0268	0.1275	-0.3915	0.0638	0.8291	0.2310
719	3	0	10	-0.0272	0.1323	-0.3894	0.0664	0.8284	0.2462

* Indicates model was close to heave stop

TABLE 8.321.2 - NON-DIMENSIONAL STABILITY DATA IN BODY AXES AT TRANSOM

30 deg Deadrise, L/R = 0.234, Cv = 1.5

RUN	Trim deg	Roll deg	Yaw deg	X'	Y'	Z'	K'	M'	N'
680	3	0	15	-0.0382	0.2722	-0.3932	0.1286	0.9457	0.5271
723	3	0	15	-0.0390	0.2732	-0.3922	0.1284	0.9459	0.5332
765	3	10	-15	-0.0267	-0.2349	-0.3572	-0.1132	0.7672	-0.6365
761	3	10	-10	-0.0242	-0.1546	-0.3701	-0.0765	0.7249	-0.4160
757	3	10	-5	-0.0213	-0.0964	-0.3813	-0.0505	0.7297	-0.2603
727	3	10	0	-0.0204	-0.0557	-0.3874	-0.0320	0.7368	-0.1509
753	3	10	5	-0.0216	-0.0237	-0.3931	-0.0181	0.7684	-0.0834
731	3	10	10	-0.0245	0.0417	-0.4059	0.0103	0.8423	0.0455
749	3	10	15	-0.0341	0.1628	-0.4256	0.0650	0.9849	0.2880
796	3	20	-15	-0.0294	-0.2506	-0.3267	-0.1231	0.7252	-0.6289
792	3	20	-10	-0.0239	-0.2018	-0.3441	-0.1054	0.6803	-0.4810
788	3	20	-5	-0.0206	-0.1596	-0.3594	-0.0866	0.6815	-0.3677
772	3	20	0	-0.0207	-0.1230	-0.3704	-0.0712	0.7065	-0.2808
776	3	20	5	-0.0220	-0.0890	-0.3851	-0.0580	0.7552	-0.2157
780	3	20	10	-0.0242	-0.0333	-0.4055	-0.0357	0.8329	-0.1171
784	3	20	15	-0.0322	0.0548	-0.4391	0.0009	0.9927	0.0290
995	6	-10	-15	-0.0112	-0.0555	-0.4098	-0.0111	0.6378	-0.1276
990	6	-10	-10	-0.0104	0.0109	-0.3980	0.0177	0.5939	-0.0086
991	6	-10	-10	-0.0117	0.0106	-0.3982	0.0177	0.5953	-0.0111
986	6	-10	-5	-0.0102	0.0577	-0.3887	0.0414	0.5807	0.0718
960	6	-10	0	-0.0096	0.0999	-0.3801	0.0627	0.5772	0.1403
961	6	-10	0	-0.0090	0.0983	-0.3825	0.0616	0.5800	0.1351
966	6	-10	5	-0.0112	0.1505	-0.3724	0.0860	0.5946	0.2168
978	6	-10	10	-0.0159	0.2357	-0.3568	0.1243	0.6153	0.3404
982	6	-10	15	-0.0245	0.3772	-0.3339	0.1909	0.6551	0.5751
865	6	0	-15	-0.0125	-0.1435	-0.3941	-0.0617	0.6156	-0.2844
861	6	0	-10	-0.0111	-0.0652	-0.3939	-0.0269	0.5835	-0.1415
857	6	0	-5	-0.0116	-0.0195	-0.3940	-0.0046	0.5720	-0.0614
840	6	0	0	-0.0103	0.0269	-0.3896	0.0200	0.5705	0.0203
845	6	0	5	-0.0122	0.0759	-0.3919	0.0450	0.5953	0.0944
849	6	0	10	-0.0164	0.1536	-0.3934	0.0787	0.6410	0.2097
853	6	0	15	-0.0233	0.2906	-0.3952	0.1408	0.7237	0.4271
924	6	10	-15	-0.0125	-0.2154	-0.3622	-0.1065	0.5800	-0.3940
920	6	10	-10	-0.0121	-0.1370	-0.3760	-0.0697	0.5697	-0.2531
916	6	10	-5	-0.0095	-0.0816	-0.3855	-0.0440	0.5704	-0.1523
870	6	10	0	-0.0113	-0.0430	-0.3914	-0.0236	0.5788	-0.0928
871	6	10	0	-0.0117	-0.0441	-0.3923	-0.0248	0.5718	-0.0962
889	6	10	5	-0.0110	0.0044	-0.4008	0.0005	0.6047	-0.0192
893	6	10	10	-0.0110	0.0637	-0.4102	0.0294	0.6555	0.0622
894	6	10	10	-0.0131	0.0678	-0.4122	0.0313	0.6568	0.0687
899	6	10	15	-0.0184	0.1688	-0.4317	0.0755	0.7476	0.2129
956	6	20	-15	-0.0132	-0.2526	-0.3264	-0.1307	0.5546	-0.4319
952	6	20	-10	-0.0124	-0.1976	-0.3475	-0.1057	0.5367	-0.3300
947	6	20	-5	-0.0099	-0.1456	-0.3650	-0.0822	0.5481	-0.2437
929	6	20	0	-0.0110	-0.1058	-0.3796	-0.0629	0.5663	-0.1884
933	6	20	5	-0.0126	-0.0565	-0.3977	-0.0390	0.6054	-0.1253
937	6	20	10	-0.0116	-0.0034	-0.4169	-0.0108	0.6675	-0.0625
941	6	20	15	-0.0162	0.0685	-0.4447	0.0224	0.7495	0.0340
942	6	20	15	-0.0152	0.0627	-0.4425	0.0193	0.7416	0.0208

* Indicates model was close to heave stop

TABLE 8.323.1 - NON-DIMENSIONAL STABILITY DATA IN BODY AXES AT TRANSOM

30 deg Deadrise, L/R = 0.234, Cv = 3

RUN	Trim deg	Roll deg	Yaw deg	X'	Y'	Z'	K'	M'	N'
1128 *	0	-10	-15	-0.0548	-0.2525	-0.1438	-0.1115	0.4679	-0.9462
1124	0	-10	-10	-0.0440	-0.1089	-0.1178	-0.0408	0.3848	-0.4684
1120	0	-10	-5	-0.0292	-0.0282	-0.1035	-0.0074	0.3081	-0.1638
1103	0	-10	0	-0.0262	0.0126	-0.0964	0.0092	0.2745	-0.0034
1108	0	-10	5	-0.0299	0.0514	-0.0900	0.0256	0.2805	0.1101
1112	0	-10	10	-0.0525	0.1722	-0.0684	0.0781	0.2888	0.4010
1115	0	-10	15	-0.0169	0.0737	-0.0858	0.0427	0.1867	0.1860
1026	0	0	-15	-0.0256	-0.1010	-0.0973	-0.0543	0.4239	-0.3873
1022	0	0	-10	-0.0419	-0.1371	-0.0975	-0.0560	0.2776	-0.5489
1018	0	0	-5	-0.0304	-0.0469	-0.0971	-0.0182	0.2781	-0.2272
1005	0	0	0	-0.0276	-0.0044	-0.0970	-0.0006	0.2839	-0.0673
1009	0	0	5	-0.0297	0.0347	-0.0967	0.0174	0.3140	0.0562
1013 *	0	0	10	-0.0552	0.1628	-0.0974	0.0729	0.3679	0.3606
1060	0	10	-15	-0.0196	-0.0652	-0.0873	-0.0369	0.3331	-0.2416
1056	0	10	-10	-0.0363	-0.1298	-0.0759	-0.0556	0.2346	-0.4994
1052	0	10	-5	-0.0343	-0.0632	-0.0876	-0.0277	0.2429	-0.2528
1037	0	10	0	-0.0312	-0.0214	-0.0950	-0.0111	0.2643	-0.1066
1041	0	10	5	-0.0314	0.0195	-0.1017	0.0084	0.3142	0.0073
1046	0	10	10	-0.0499	0.1265	-0.1209	0.0565	0.4122	0.2668
1098	0	20	-15	-0.0414	-0.1381	-0.0529	-0.0646	0.2998	-0.5282
1094	0	20	-10	-0.0401	-0.1060	-0.0648	-0.0502	0.2913	-0.4165
1089	0	20	-5	-0.0307	-0.0740	-0.0759	-0.0342	0.2045	-0.2714
1065	0	20	0	-0.0302	-0.0398	-0.0889	-0.0215	0.2412	-0.1521
1069	0	20	5	-0.0320	-0.0027	-0.1018	-0.0061	0.2941	-0.0457
1074	0	20	10	-0.0425	0.0785	-0.1321	0.0325	0.4197	0.1639
1078 *	0	20	15	-0.0558	0.2151	-0.1818	0.0973	0.6194	0.4700
834	3	-10	-15	-0.0222	-0.1434	-0.1251	-0.0592	0.3431	-0.4382
830	3	-10	-10	-0.0193	-0.0474	-0.1084	-0.0144	0.2490	-0.1659
826	3	-10	-5	-0.0174	0.0030	-0.0994	0.0074	0.2150	-0.0268
802	3	-10	0	-0.0182	0.0364	-0.0932	0.0227	0.2044	0.0562
814	3	-10	5	-0.0187	0.0710	-0.0867	0.0379	0.2042	0.1233
818	3	-10	10	-0.0235	0.1474	-0.0736	0.0727	0.2289	0.2620
822	3	-10	15	-0.0107	0.0947	-0.0828	0.0520	0.1005	0.1271
697	3	0	-15	-0.0243	-0.1799	-0.0985	-0.0845	0.2892	-0.5172
690	3	0	-10	-0.0222	-0.0794	-0.0988	-0.0341	0.2394	-0.2613
701	3	0	-10	-0.0204	-0.0708	-0.0985	-0.0302	0.2324	-0.2281
706	3	0	-5	-0.0177	-0.0184	-0.0985	-0.0058	0.2044	-0.0836
659	3	0	0	-0.0190	0.0151	-0.0981	0.0103	0.2047	-0.0038
710	3	0	0	-0.0172	0.0145	-0.0988	0.0099	0.2030	0.0012
663	3	0	5	-0.0189	0.0560	-0.0983	0.0305	0.2240	0.0858
714	3	0	5	-0.0170	0.0520	-0.0982	0.0281	0.2185	0.0792
677	3	0	10	-0.0241	0.1294	-0.0988	0.0640	0.2708	0.2247
720	3	0	10	-0.0246	0.1305	-0.0987	0.0646	0.2731	0.2291
724	3	0	15	-0.0369	0.3081	-0.0991	0.1477	0.4114	0.6059

* Indicates model was close to heave stop

TABLE 8.323.2 - NON-DIMENSIONAL STABILITY DATA IN BODY AXES AT TRANSOM

30 deg Deadrise, L/R = 0.234, Cv = 3

RUN	Trim deg	Roll deg	Yaw deg	X'	Y'	Z'	K'	M'	N'
766	3	10	-15	-0.0111	-0.0639	-0.0884	-0.0332	0.1938	-0.1406
762	3	10	-10	-0.0227	-0.0869	-0.0846	-0.0423	0.2120	-0.2581
758	3	10	-5	-0.0184	-0.0356	-0.0937	-0.0177	0.2031	-0.1211
728	3	10	0	-0.0159	-0.0032	-0.0994	-0.0017	0.1988	-0.0370
754	3	10	5	-0.0154	0.0274	-0.1047	0.0140	0.2125	0.0222
732	3	10	10	-0.0189	0.0814	-0.1145	0.0394	0.2613	0.1256
744	3	10	10	-0.0188	0.0816	-0.1137	0.0394	0.2608	0.1243
750	3	10	15	-0.0299	0.2122	-0.1379	0.1007	0.4259	0.3741
797	3	20	-15	-0.0121	-0.0743	-0.0778	-0.0414	0.1959	-0.1558
793	3	20	-10	-0.0172	-0.0719	-0.0790	-0.0389	0.2194	-0.1845
789	3	20	-5	-0.0189	-0.0495	-0.0868	-0.0271	0.1890	-0.1357
773	3	20	0	-0.0159	-0.0198	-0.0975	-0.0132	0.1991	-0.0743
777	3	20	5	-0.0148	0.0041	-0.1065	-0.0007	0.2075	-0.0290
781	3	20	10	-0.0155	0.0438	-0.1207	0.0176	0.2310	0.0344
785	3	20	15	-0.0165	0.1001	-0.1408	0.0411	0.2769	0.1240
996	6	-10	-15	-0.0082	-0.0422	-0.1078	-0.0165	0.1480	-0.0616
992	6	-10	-10	-0.0075	-0.0077	-0.1016	-0.0004	0.1406	-0.0124
987	6	-10	-5	-0.0041	0.0185	-0.0962	0.0127	0.1413	0.0254
963	6	-10	0	-0.0079	0.0418	-0.0928	0.0252	0.1508	0.0579
967	6	-10	5	-0.0103	0.0784	-0.0866	0.0427	0.1502	0.0984
979	6	-10	10	-0.0105	0.1233	-0.0787	0.0625	0.1536	0.1495
983	6	-10	15	-0.0159	0.2419	-0.0583	0.1188	0.1886	0.3296
866	6	0	-15	-0.0103	-0.0732	-0.0987	-0.0330	0.1620	-0.1304
862	6	0	-10	-0.0081	-0.0302	-0.0986	-0.0137	0.1407	-0.0543
858	6	0	-5	-0.0080	-0.0021	-0.0986	0.0010	0.1367	-0.0107
842	6	0	0	-0.0061	0.0233	-0.0983	0.0149	0.1374	0.0235
846	6	0	5	-0.0088	0.0526	-0.0986	0.0299	0.1488	0.0638
850	6	0	10	-0.0113	0.0993	-0.0989	0.0517	0.1660	0.1204
854	6	0	15	-0.0160	0.2043	-0.0999	0.0998	0.2264	0.2745
925	6	10	-15	-0.0118	-0.0972	-0.0833	-0.0479	0.1544	-0.1634
921	6	10	-10	-0.0081	-0.0430	-0.0921	-0.0222	0.1490	-0.0771
917	6	10	-5	-0.0066	-0.0200	-0.0958	-0.0104	0.1375	-0.0390
882	6	10	0	-0.0062	0.0024	-0.1001	0.0017	0.1335	-0.0094
883	6	10	0	-0.0060	0.0026	-0.1004	0.0019	0.1302	-0.0099
884	6	10	0	-0.0072	0.0020	-0.1006	0.0016	0.1312	-0.0112
885	6	10	0	-0.0062	0.0024	-0.1007	0.0017	0.1344	-0.0095
886	6	10	0	-0.0065	0.0026	-0.1004	0.0019	0.1317	-0.0102
890	6	10	5	-0.0072	0.0294	-0.1055	0.0158	0.1319	0.0224
895	6	10	10	-0.0086	0.0618	-0.1117	0.0312	0.1416	0.0563
896	6	10	10	-0.0083	0.0643	-0.1115	0.0326	0.1392	0.0618
900	6	10	15	-0.0094	0.1157	-0.1202	0.0557	0.1667	0.1287
957	6	20	-15	-0.0097	-0.1059	-0.0665	-0.0540	0.1291	-0.1580
953	6	20	-10	-0.0093	-0.0607	-0.0830	-0.0325	0.1409	-0.1001
948	6	20	-5	-0.0057	-0.0335	-0.0923	-0.0194	0.1424	-0.0614
930	6	20	0	-0.0066	-0.0176	-0.0984	-0.0105	0.1337	-0.0389
934	6	20	5	-0.0050	0.0005	-0.1041	-0.0017	0.1249	-0.0168
939	6	20	10	-0.0064	0.0238	-0.1136	0.0089	0.1233	0.0064
944	6	20	15	-0.0075	0.0558	-0.1249	0.0226	0.1292	0.0380

* Indicates model was close to heave stop

TABLE 8.324.1 - NON-DIMENSIONAL STABILITY DATA IN BODY AXES AT TRANSOM

30 deg Deadrise, L/R = 0.234, Cv = 4

RUN	Trim deg	Roll deg	Yaw deg	X'	Y'	Z'	K'	M'	N'
1125 *	0	-10	-10	-0.0454	-0.0998	-0.0729	-0.0384	0.2734	-0.4670
1121	0	-10	-5	-0.0282	-0.0343	-0.0614	-0.0119	0.2237	-0.1841
1104	0	-10	0	-0.0244	0.0065	-0.0546	0.0050	0.1852	-0.0191
1109	0	-10	5	-0.0333	0.0561	-0.0459	0.0264	0.1915	0.0978
1116	0	-10	15	-0.0073	0.0421	-0.0480	0.0205	0.0846	0.0934
1027	0	0	-15	-0.0093	-0.0514	-0.0549	-0.0252	0.1831	-0.1631
1023 *	0	0	-10	-0.0477	-0.0861	-0.0549	-0.0344	0.1755	-0.4584
1019	0	0	-5	-0.0298	-0.0450	-0.0550	-0.0168	0.1847	-0.2308
1006	0	0	0	-0.0259	-0.0045	-0.0553	-0.0007	0.1849	-0.0690
1010	0	0	5	-0.0288	0.0377	-0.0548	0.0187	0.2127	0.0592
1061	0	10	-15	-0.0114	-0.0430	-0.0480	-0.0221	0.1579	-0.1388
1057	0	10	-10	-0.0365	-0.1134	-0.0357	-0.0486	0.1612	-0.4743
1053	0	10	-5	-0.0338	-0.0555	-0.0459	-0.0225	0.1482	-0.2554
1038	0	10	0	-0.0294	-0.0092	-0.0538	-0.0043	0.1667	-0.0798
1042	0	10	5	-0.0275	0.0270	-0.0601	0.0139	0.2135	0.0216
1047 *	0	10	10	-0.0529	0.1356	-0.0792	0.0630	0.2930	0.2848
1099	0	20	-15	-0.0199	-0.0606	-0.0358	-0.0299	0.1826	-0.2142
1095	0	20	-10	-0.0331	-0.0748	-0.0308	-0.0367	0.2079	-0.3302
1091	0	20	-5	-0.0285	-0.0563	-0.0375	-0.0249	0.1232	-0.2357
1066	0	20	0	-0.0298	-0.0227	-0.0502	-0.0118	0.1503	-0.1138
1070	0	20	5	-0.0306	0.0156	-0.0642	0.0059	0.2004	-0.0069
1075	0	20	10	-0.0359	0.0864	-0.0893	0.0405	0.3122	0.1783
835	3	-10	-15	-0.0210	-0.1456	-0.0821	-0.0629	0.2644	-0.4422
831	3	-10	-10	-0.0181	-0.0506	-0.0654	-0.0179	0.1665	-0.1675
827	3	-10	-5	-0.0165	-0.0020	-0.0572	0.0033	0.1367	-0.0330
803	3	-10	0	-0.0155	0.0314	-0.0506	0.0192	0.1305	0.0471
815	3	-10	5	-0.0185	0.0652	-0.0449	0.0341	0.1284	0.1120
819	3	-10	10	-0.0210	0.1300	-0.0336	0.0638	0.1425	0.2256
823	3	-10	15	-0.0037	0.0486	-0.0470	0.0258	0.0178	0.0442
696	3	0	-15	-0.0232	-0.1722	-0.0554	-0.0823	0.2124	-0.5009
702	3	0	-10	-0.0186	-0.0662	-0.0563	-0.0290	0.1554	-0.2171
703	3	0	-10	-0.0189	-0.0668	-0.0563	-0.0293	0.1565	-0.2198
707	3	0	-5	-0.0160	-0.0145	-0.0554	-0.0044	0.1239	-0.0694
660	3	0	0	-0.0188	0.0144	-0.0560	0.0096	0.1321	-0.0025
709	3	0	0	-0.0154	0.0158	-0.0556	0.0103	0.1215	0.0089
664	3	0	5	-0.0186	0.0578	-0.0557	0.0314	0.1466	0.0888
715	3	0	5	-0.0153	0.0529	-0.0556	0.0285	0.1331	0.0775
678	3	0	10	-0.0209	0.1242	-0.0554	0.0618	0.1808	0.2122
721	3	0	10	-0.0216	0.1254	-0.0557	0.0624	0.1837	0.2155

* Indicates model was close to heave stop

TABLE 8.324.2 - NON-DIMENSIONAL STABILITY DATA IN BODY AXES AT TRANSOM
30 deg Deadrise, L/R = 0.234, Cv = 4

RUN	Trim deg	Roll deg	Yaw deg	X'	Y'	Z'	K'	M'	N'
767	3	10	-15	-0.0077	-0.0401	-0.0483	-0.0217	0.0778	-0.0714
768	3	10	-15	-0.0073	-0.0410	-0.0487	-0.0218	0.0765	-0.0730
763	3	10	-10	-0.0183	-0.0668	-0.0450	-0.0336	0.1399	-0.2055
759	3	10	-5	-0.0162	-0.0238	-0.0525	-0.0119	0.1261	-0.0959
729	3	10	0	-0.0130	0.0069	-0.0570	0.0039	0.1099	-0.0114
755	3	10	5	-0.0133	0.0355	-0.0624	0.0186	0.1194	0.0406
746	3	10	10	-0.0147	0.0825	-0.0703	0.0406	0.1520	0.1261
747	3	10	10	-0.0148	0.0811	-0.0704	0.0399	0.1522	0.1228
751	3	10	15	-0.0241	0.1955	-0.0907	0.0945	0.3011	0.3475
798	3	20	-15	-0.0084	-0.0438	-0.0430	-0.0257	0.0851	-0.0727
794	3	20	-10	-0.0135	-0.0423	-0.0436	-0.0250	0.1235	-0.1060
790	3	20	-5	-0.0159	-0.0283	-0.0488	-0.0163	0.1206	-0.0974
774	3	20	0	-0.0117	-0.0046	-0.0570	-0.0046	0.1143	-0.0336
778	3	20	5	-0.0116	0.0160	-0.0650	0.0055	0.1124	0.0034
782	3	20	10	-0.0123	0.0445	-0.0754	0.0177	0.1204	0.0446
786	3	20	15	-0.0118	0.0883	-0.0904	0.0350	0.1412	0.1068
997	6	-10	-15	-0.0081	-0.0332	-0.0623	-0.0130	0.0544	-0.0400
993	6	-10	-10	-0.0072	-0.0066	-0.0578	-0.0004	0.0532	-0.0089
988	6	-10	-5	-0.0051	0.0146	-0.0537	0.0101	0.0549	0.0162
964	6	-10	0	-0.0076	0.0334	-0.0507	0.0199	0.0656	0.0405
968	6	-10	5	-0.0080	0.0550	-0.0473	0.0300	0.0640	0.0588
998	6	-10	5	-0.0078	0.0556	-0.0469	0.0303	0.0635	0.0609
980	6	-10	10	-0.0054	0.0671	-0.0440	0.0350	0.0486	0.0630
999	6	-10	10	-0.0065	0.0729	-0.0437	0.0379	0.0526	0.0698
984	6	-10	15	-0.0070	0.1138	-0.0363	0.0567	0.0577	0.1070
867	6	0	-15	-0.0104	-0.0603	-0.0564	-0.0278	0.0701	-0.0913
863	6	0	-10	-0.0087	-0.0237	-0.0565	-0.0108	0.0541	-0.0346
859	6	0	-5	-0.0064	0.0018	-0.0556	0.0025	0.0480	0.0007
843	6	0	0	-0.0052	0.0229	-0.0553	0.0137	0.0499	0.0227
847	6	0	5	-0.0051	0.0446	-0.0554	0.0244	0.0536	0.0428
851	6	0	10	-0.0058	0.0710	-0.0554	0.0364	0.0543	0.0689
855	6	0	15	-0.0039	0.0898	-0.0548	0.0428	0.0476	0.0776
926	6	10	-15	-0.0123	-0.0788	-0.0429	-0.0392	0.0729	-0.1202
922	6	10	-10	-0.0082	-0.0317	-0.0508	-0.0168	0.0628	-0.0460
918	6	10	-5	-0.0067	-0.0118	-0.0551	-0.0061	0.0542	-0.0175
887	6	10	0	-0.0054	0.0070	-0.0577	0.0037	0.0505	0.0051
891	6	10	5	-0.0063	0.0277	-0.0617	0.0137	0.0512	0.0235
897	6	10	10	-0.0057	0.0510	-0.0655	0.0240	0.0546	0.0430
901	6	10	15	-0.0030	0.0798	-0.0688	0.0355	0.0553	0.0658
902	6	10	15	-0.0029	0.0802	-0.0689	0.0357	0.0557	0.0671
903	6	10	15	-0.0029	0.0799	-0.0686	0.0356	0.0557	0.0670
914	6	10	15	-0.0058	0.0848	-0.0717	0.0382	0.0609	0.0724
958	6	20	-15	-0.0035	-0.0321	-0.0472	-0.0187	0.0342	-0.0229
954	6	20	-10	-0.0099	-0.0395	-0.0449	-0.0221	0.0673	-0.0549
949	6	20	-5	-0.0072	-0.0194	-0.0527	-0.0118	0.0625	-0.0261
950	6	20	-5	-0.0069	-0.0202	-0.0526	-0.0123	0.0613	-0.0279
931	6	20	0	-0.0062	-0.0073	-0.0562	-0.0055	0.0505	-0.0087
935	6	20	5	-0.0040	0.0049	-0.0602	0.0001	0.0442	0.0030
940	6	20	10	-0.0043	0.0191	-0.0653	0.0059	0.0468	0.0142
945	6	20	15	-0.0048	0.0366	-0.0717	0.0123	0.0522	0.0260

* Indicates model was close to heave stop

TABLE 9.301 - RUDDER DATA IN WIND AXES WITHOUT AIR TARES

Trim = 3 deg Roll = Yaw = 0 deg

30 deg Deadrise, L/R = 0.000, Cv = 1.5

RUN	Rudder deg	Speed fps	X lb	Y lb	Z lb	K lb-ft	M lb-ft	N lb-ft	Heave in	TD in
1712	-20	7.32	1.29	0.20	11.49	0.21	-6.74	0.48	2.21	3.11
1713	-20	7.32	1.32	0.16	11.49	0.20	-6.75	0.50	2.21	3.11
1709	-15	7.34	1.39	-0.30	11.49	0.39	-5.48	1.34	2.13	3.19
1706	-10	7.34	1.28	-0.11	11.49	0.32	-5.46	1.07	2.12	3.20
1703	-5	7.35	1.21	-0.05	11.49	0.26	-5.49	0.56	2.13	3.19
1700	0	7.37	1.16	-0.04	11.49	0.21	-5.63	0.06	2.16	3.16
1724	5	7.33	1.26	0.71	11.49	-0.02	-5.44	-0.52	2.14	3.18
1719	10	7.33	1.28	0.95	11.49	-0.13	-5.50	-1.02	2.15	3.17
1718	15	7.33	1.48	1.19	11.49	-0.23	-5.46	-1.27	2.15	3.17

TABLE 9.303 - RUDDER DATA IN WIND AXES WITHOUT AIR TARES

Trim = 3 deg Roll = Yaw = 0 deg

30 deg Deadrise, L/R = 0.000, Cv = 3

RUN	Rudder deg	Speed fps	X lb	Y lb	Z lb	K lb-ft	M lb-ft	N lb-ft	Heave in	TD in
1714	-20	14.74	2.44	-0.58	11.49	0.49	-13.03	0.95	3.27	2.05
1710	-15	14.76	3.25	-2.47	11.49	1.21	-4.78	4.92	2.62	2.70
1707	-10	14.76	2.76	-2.23	11.49	1.06	-4.83	4.04	2.62	2.70
1704	-5	14.77	2.49	-1.12	11.49	0.62	-4.82	2.12	2.64	2.68
1701	0	14.74	2.47	-0.25	11.49	0.21	-4.81	0.23	2.63	2.69
1723	5	14.76	2.55	1.16	11.49	-0.33	-4.84	-1.91	2.63	2.69
1720	10	14.76	2.89	2.20	11.49	-0.77	-4.89	-3.69	2.63	2.69
1717	15	14.74	3.47	2.53	11.49	-0.93	-5.13	-4.51	2.64	2.68

TABLE 9.304 - RUDDER DATA IN WIND AXES WITHOUT AIR TARES

Trim = 3 deg Roll = Yaw = 0 deg

30 deg Deadrise, L/R = 0.000, Cv = 4

RUN	Rudder deg	Speed fps	X lb	Y lb	Z lb	K lb-ft	M lb-ft	N lb-ft	Heave in	TD in
1715	-20	19.62	2.92	-0.63	11.49	0.63	-17.43	1.17	3.92	1.40
1711	-15	19.62	5.01	-4.49	11.49	2.09	-4.63	8.75	2.85	2.47
1708	-10	19.62	4.12	-3.49	11.49	1.61	-4.49	6.93	2.86	2.46
1705	-5	19.65	3.75	-1.96	11.49	0.92	-4.40	3.66	2.85	2.47
1702	0	19.65	3.69	-0.41	11.49	0.22	-4.55	0.52	2.91	2.41
1722	5	19.62	3.77	2.01	11.49	-0.77	-4.57	-3.38	2.88	2.44
1721	10	19.62	4.35	3.60	11.49	-1.46	-4.71	-6.44	2.90	2.42
1716	15	19.62	5.41	4.44	11.49	-1.83	-5.18	-7.95	2.90	2.42

TABLE 10.301 - RUDDER DATA IN BODY AXES AT PIVOT

Trim = 3 deg Roll = Yaw = 0 deg

30 deg Deadrise, L/R = 0.000, Cv = 1.5

RUN	Rudder deg	X lb	Y lb	Z lb	K lb-ft	M lb-ft	N lb-ft
1712	-20	-0.69	0.20	-11.54	0.19	-6.74	0.49
1713	-20	-0.72	0.16	-11.54	0.18	-6.75	0.51
1709	-15	-0.79	-0.30	-11.55	0.32	-5.48	1.36
1706	-10	-0.68	-0.11	-11.54	0.27	-5.46	1.08
1703	-5	-0.61	-0.05	-11.54	0.23	-5.49	0.57
1700	0	-0.56	-0.04	-11.54	0.21	-5.63	0.07
1724	5	-0.66	0.71	-11.54	0.01	-5.44	-0.52
1719	10	-0.68	0.95	-11.54	-0.08	-5.50	-1.02
1718	15	-0.88	1.19	-11.55	-0.16	-5.46	-1.28

TABLE 10.303 - RUDDER DATA IN BODY AXES AT PIVOT

Trim = 3 deg Roll = Yaw = 0 deg

30 deg Deadrise, L/R = 0.000, Cv = 3

RUN	Rudder deg	X lb	Y lb	Z lb	K lb-ft	M lb-ft	N lb-ft
1714	-20	-1.83	-0.58	-11.60	0.44	-13.03	0.97
1710	-15	-2.64	-2.47	-11.64	0.95	-4.78	4.98
1707	-10	-2.15	-2.23	-11.62	0.84	-4.83	4.09
1704	-5	-1.88	-1.12	-11.60	0.50	-4.82	2.15
1701	0	-1.86	-0.25	-11.60	0.19	-4.81	0.24
1723	5	-1.94	1.16	-11.61	-0.23	-4.84	-1.93
1720	10	-2.28	2.20	-11.63	-0.58	-4.89	-3.73
1717	15	-2.86	2.53	-11.66	-0.70	-5.13	-4.55

TABLE 10.304 - RUDDER DATA IN BODY AXES AT PIVOT

Trim = 3 deg Roll = Yaw = 0 deg

30 deg Deadrise, L/R = 0.000, Cv = 4

RUN	Rudder deg	X lb	Y lb	Z lb	K lb-ft	M lb-ft	N lb-ft
1715	-20	-2.32	-0.63	-11.63	0.57	-17.43	1.20
1711	-15	-4.40	-4.49	-11.74	1.63	-4.63	8.85
1708	-10	-3.51	-3.49	-11.69	1.25	-4.49	7.00
1705	-5	-3.14	-1.96	-11.67	0.73	-4.40	3.70
1702	0	-3.08	-0.41	-11.67	0.19	-4.55	0.53
1722	5	-3.16	2.01	-11.67	-0.59	-4.57	-3.42
1721	10	-3.74	3.60	-11.70	-1.12	-4.71	-6.51
1716	15	-4.80	4.44	-11.76	-1.41	-5.18	-8.03

TABLE 11.301 - RUDDER DATA IN BODY AXES AT TRANSOM

Trim = 3 deg Roll = Yaw = 0 deg

30 deg Deadrise, L/R = 0.000, Cv = 1.5

RUN	Rudder deg	X lb	Y lb	Z lb	K lb-ft	M lb-ft	N lb-ft
1712	-20	-0.69	0.20	-11.54	0.26	15.14	0.87
1713	-20	-0.72	0.16	-11.54	0.23	15.14	0.81
1709	-15	-0.79	-0.30	-11.55	0.22	16.44	0.81
1706	-10	-0.68	-0.11	-11.54	0.23	16.42	0.88
1703	-5	-0.61	-0.05	-11.54	0.22	16.35	0.48
1700	0	-0.56	-0.04	-11.54	0.20	16.19	0.00
1724	5	-0.66	0.71	-11.54	0.26	16.43	0.82
1719	10	-0.68	0.95	-11.54	0.26	16.38	0.77
1718	15	-0.88	1.19	-11.55	0.25	16.50	0.96

TABLE 11.303 - RUDDER DATA IN BODY AXES AT TRANSOM

Trim = 3 deg Roll = Yaw = 0 deg

30 deg Deadrise, L/R = 0.000, Cv = 3

RUN	Rudder deg	X lb	Y lb	Z lb	K lb-ft	M lb-ft	N lb-ft
1714	-20	-1.83	-0.58	-11.60	0.23	9.36	-0.12
1710	-15	-2.64	-2.47	-11.64	0.09	17.97	0.34
1707	-10	-2.15	-2.23	-11.62	0.07	17.70	-0.10
1704	-5	-1.88	-1.12	-11.60	0.12	17.59	0.04
1701	0	-1.86	-0.25	-11.60	0.11	17.59	-0.23
1723	5	-1.94	1.16	-11.61	0.17	17.60	0.24
1720	10	-2.28	2.20	-11.63	0.18	17.70	0.39
1717	15	-2.86	2.53	-11.66	0.18	17.71	0.19

TABLE 11.304 - RUDDER DATA IN BODY AXES AT TRANSOM

Trim = 3 deg Roll = Yaw = 0 deg

30 deg Deadrise, L/R = 0.000, Cv = 4

RUN	Rudder deg	X lb	Y lb	Z lb	K lb-ft	M lb-ft	N lb-ft
1715	-20	-2.32	-0.63	-11.63	0.35	5.17	0.02
1711	-15	-4.40	-4.49	-11.74	0.08	18.90	0.43
1708	-10	-3.51	-3.49	-11.69	0.04	18.64	0.46
1705	-5	-3.14	-1.96	-11.67	0.05	18.57	0.03
1702	0	-3.08	-0.41	-11.67	0.05	18.39	-0.24
1722	5	-3.16	2.01	-11.67	0.10	18.41	0.35
1721	10	-3.74	3.60	-11.70	0.12	18.53	0.25
1716	15	-4.80	4.44	-11.76	0.12	18.53	0.29

TABLE 12.301 - NON-DIMENSIONAL RUDDER DATA IN BODY AXES AT TRANSOM

Trim = 3 deg Roll = Yaw = 0 deg

30 deg Deadrise, L/R = 0.000, Cv = 1.5

RUN	Rudder deg	X'	Y'	Z'	K'	M'	N'
1712	-20	-0.0237	0.0070	-0.3956	0.0117	0.6920	0.0399
1713	-20	-0.0247	0.0056	-0.3957	0.0106	0.6921	0.0372
1709	-15	-0.0270	-0.0101	-0.3937	0.0099	0.7475	0.0368
1706	-10	-0.0232	-0.0036	-0.3935	0.0104	0.7462	0.0402
1703	-5	-0.0208	-0.0016	-0.3923	0.0098	0.7414	0.0219
1700	0	-0.0190	-0.0012	-0.3900	0.0088	0.7300	0.0002
1724	5	-0.0226	0.0244	-0.3945	0.0117	0.7487	0.0373
1719	10	-0.0233	0.0326	-0.3945	0.0116	0.7464	0.0350
1718	15	-0.0301	0.0408	-0.3949	0.0115	0.7523	0.0435

TABLE 12.303 - NON-DIMENSIONAL RUDDER DATA IN BODY AXES AT TRANSOM

Trim = 3 deg Roll = Yaw = 0 deg

30 deg Deadrise, L/R = 0.000, Cv = 3

RUN	Rudder deg	X'	Y'	Z'	K'	M'	N'
1714	-20	-0.0155	-0.0049	-0.0981	0.0026	0.1055	-0.0013
1710	-15	-0.0223	-0.0208	-0.0982	0.0010	0.2020	0.0039
1707	-10	-0.0182	-0.0188	-0.0980	0.0008	0.1990	-0.0011
1704	-5	-0.0159	-0.0095	-0.0977	0.0013	0.1975	0.0005
1701	0	-0.0158	-0.0021	-0.0981	0.0012	0.1983	-0.0026
1723	5	-0.0164	0.0098	-0.0979	0.0019	0.1978	0.0027
1720	10	-0.0192	0.0185	-0.0980	0.0020	0.1989	0.0044
1717	15	-0.0242	0.0214	-0.0985	0.0020	0.1997	0.0021

TABLE 12.304 - NON-DIMENSIONAL RUDDER DATA IN BODY AXES AT TRANSOM

Trim = 3 deg Roll = Yaw = 0 deg

30 deg Deadrise, L/R = 0.000, Cv = 4

RUN	Rudder deg	X'	Y'	Z'	K'	M'	N'
1715	-20	-0.0110	-0.0030	-0.0555	0.0022	0.0329	0.0001
1711	-15	-0.0210	-0.0214	-0.0560	0.0005	0.1202	0.0027
1708	-10	-0.0168	-0.0167	-0.0558	0.0002	0.1186	0.0029
1705	-5	-0.0150	-0.0093	-0.0555	0.0003	0.1178	0.0002
1702	0	-0.0147	-0.0020	-0.0555	0.0003	0.1166	-0.0015
1722	5	-0.0151	0.0096	-0.0557	0.0007	0.1171	0.0022
1721	10	-0.0179	0.0172	-0.0558	0.0008	0.1179	0.0016
1716	15	-0.0229	0.0212	-0.0561	0.0008	0.1179	0.0019

APPENDIX A

TABLE A1.300.1 - STABILITY DATA IN WIND AXES WITH AIR TARES

30 deg Deadrise, L/R = 0.000, Cv = 0

RUN	Trim deg	Roll deg	Yaw deg	Speed fps	X lb	Y lb	Z lb	K lb-ft	M lb-ft	N lb-ft	Heave in	TD in
1641	-2	-10	0	0.00	0.08	0.03	11.49	0.19	1.13	0.02	1.89	1.41
1645	-2	-10	5	0.00	0.06	0.04	11.49	0.10	1.09	0.02	1.88	1.42
1648	-2	-10	10	0.00	0.05	0.00	11.49	0.03	1.06	0.02	1.88	1.42
1651	-2	-10	15	0.00	0.08	0.05	11.49	-0.18	0.99	0.03	1.87	1.43
1588	-2	0	0	0.00	0.07	0.07	11.49	-0.03	1.17	0.03	1.91	1.45
1593	-2	0	5	0.00	0.04	0.02	11.49	-0.10	1.03	0.01	1.84	1.52
1607	-2	0	10	0.00	0.06	0.06	11.49	-0.19	1.06	0.03	1.87	1.49
1610	-2	0	15	0.00	0.07	0.06	11.49	-0.32	1.02	0.04	1.84	1.52
1614	-2	10	0	0.00	0.06	0.03	11.49	-0.22	1.16	0.02	1.87	1.43
1618	-2	10	5	0.00	0.08	0.07	11.49	-0.31	1.01	0.03	1.88	1.42
1621	-2	10	10	0.00	0.05	0.07	11.49	-0.40	0.93	0.02	1.88	1.42
1624	-2	10	15	0.00	0.08	0.08	11.49	-0.49	0.85	0.02	1.86	1.44
1628	-2	20	0	0.00	0.07	0.05	11.49	-0.33	0.75	0.02	2.01	1.10
1632	-2	20	5	0.00	0.06	0.12	11.49	-0.42	0.62	0.02	1.95	1.16
1635	-2	20	10	0.00	0.07	0.08	11.49	-0.46	0.59	0.02	1.95	1.16
1638	-2	20	15	0.00	0.06	0.08	11.49	-0.48	0.50	0.02	1.97	1.14
1571	0	-10	0	0.00	0.05	0.05	11.49	0.24	-3.30	0.01	2.01	2.08
1575	0	-10	5	0.00	0.06	0.08	11.49	0.53	-3.29	0.03	1.99	2.10
1579	0	-10	10	0.00	0.05	0.07	11.49	0.81	-3.25	0.02	2.00	2.09
1583	0	-10	15	0.00	0.06	0.07	11.49	1.13	-3.25	0.02	1.99	2.10
1511	0	0	0	0.00	0.04	0.07	11.49	0.02	-3.17	0.02	1.84	2.31
1527	0	0	5	0.00	0.06	0.07	11.49	0.29	-3.07	0.02	1.97	2.18
1532	0	0	10	0.00	0.05	0.07	11.49	0.56	-3.07	0.02	1.97	2.18
1535	0	0	15	0.00	0.06	0.14	11.49	0.85	-3.07	0.05	1.94	2.21
1539	0	10	0	0.00	-0.04	0.01	11.49	-0.21	-3.50	-0.33	1.99	2.10
1543	0	10	5	0.00	0.06	0.09	11.49	0.09	-3.39	0.02	2.00	2.09
1547	0	10	10	0.00	0.06	0.08	11.49	0.39	-3.39	0.02	2.00	2.09
1550	0	10	15	0.00	0.05	0.08	11.49	0.68	-3.39	0.03	1.98	2.11
1553	0	20	0	0.00	0.05	0.09	11.49	-0.31	-3.47	0.02	2.09	1.81
1557	0	20	5	0.00	0.05	0.09	11.49	-0.03	-3.61	0.01	2.05	1.85
1561	0	20	10	0.00	0.04	0.04	11.49	0.31	-3.50	0.02	2.12	1.78
1565	0	20	15	0.00	0.07	0.10	11.49	0.61	-3.51	0.03	2.10	1.80
1374	3	-10	0	0.00	0.04	0.07	11.49	0.29	-8.48	0.01	2.26	3.00
1379	3	-10	5	0.00	0.04	0.09	11.49	1.02	-8.35	0.03	2.28	2.98
1382	3	-10	10	0.00	0.05	0.09	11.49	1.74	-8.20	0.04	2.28	2.98
1386	3	-10	15	0.00	0.05	0.11	11.49	2.48	-8.10	0.04	2.26	3.00
1301	3	0	0	0.00	0.03	0.03	11.49	0.05	-8.27	0.01	2.06	3.26
1307	3	0	0	0.00	0.04	0.07	11.49	0.05	-8.41	0.02	2.06	3.26
1689	3	0	0	0.00	0.04	0.09	11.49	0.07	-8.56	0.11	2.20	3.12
1309	3	0	5	0.00	0.04	0.07	11.49	0.78	-8.37	0.04	2.07	3.25
1313	3	0	10	0.00	0.04	0.05	11.49	1.49	-8.16	0.05	2.08	3.24
1318	3	0	15	0.00	0.05	0.06	11.49	2.26	-8.15	0.03	2.07	3.25

* Indicates model was close to heave stop

TABLE A1.300.2 - STABILITY DATA IN WIND AXES WITH AIR TARES

30 deg Deadrise, L/R = 0.000, Cv = 0

RUN	Trim deg	Roll deg	Yaw deg	Speed fps	X lb	Y lb	Z lb	K lb-ft	M lb-ft	N lb-ft	Heave in	TD in
1324	3	10	0	0.00	0.04	0.07	11.49	-0.15	-8.35	0.01	2.13	3.13
1328	3	10	5	0.00	0.05	0.08	11.49	0.58	-8.34	0.03	2.12	3.14
1332	3	10	10	0.00	0.06	0.08	11.49	1.29	-8.25	0.04	2.12	3.14
1336	3	10	15	0.00	0.05	0.09	11.49	1.99	-8.02	0.04	2.14	3.12
1342	3	20	0	0.00	0.04	0.08	11.49	-0.30	-8.60	0.01	2.15	2.92
1359	3	20	5	0.00	0.05	0.06	11.49	0.46	-8.83	0.02	2.29	2.78
1363	3	20	10	0.00	0.06	0.10	11.49	1.22	-8.57	0.03	2.34	2.73
1367	3	20	15	0.00	0.06	0.11	11.49	1.97	-8.47	0.03	2.32	2.75
1494	6	-10	0	0.00	0.05	0.06	11.49	0.31	-11.65	0.00	2.58	3.84
1498	6	-10	5	0.00	0.04	0.09	11.49	1.33	-11.67	0.03	2.55	3.87
1502	6	-10	10	0.00	0.06	0.11	11.49	2.31	-11.48	0.03	2.54	3.88
1506	6	-10	15	0.00	0.05	0.08	11.49	3.31	-11.23	0.03	2.57	3.85
1405	6	0	0	0.00	0.04	0.07	11.49	0.08	-11.49	0.00	2.68	3.80
1438	6	0	0	0.00	0.02	0.02	11.49	0.09	-11.96	0.00	2.67	3.81
1409	6	0	5	0.00	0.04	0.07	11.49	1.10	-11.68	0.02	2.65	3.83
1440	6	0	10	0.00	0.06	0.08	11.49	2.05	-11.23	0.04	2.76	3.72
1444	6	0	15	0.00	0.05	0.08	11.49	3.06	-11.08	0.02	2.77	3.71
1455	6	0	15	0.00	0.05	0.04	11.49	3.05	-11.03	0.02	2.72	3.76
1460	6	10	0	0.00	0.04	0.06	11.49	-0.13	-11.78	0.02	2.57	3.85
1464	6	10	5	0.00	0.05	0.11	11.49	0.88	-11.60	0.03	2.59	3.83
1468	6	10	10	0.00	0.05	0.10	11.49	1.91	-11.57	0.04	2.57	3.85
1472	6	10	15	0.00	0.06	0.12	11.49	2.97	-11.61	0.04	2.54	3.88
1477	6	20	0	0.00	0.06	0.11	11.49	-0.29	-11.78	0.04	2.60	3.63
1481	6	20	5	0.00	0.05	0.10	11.49	0.73	-11.81	0.02	2.60	3.63
1485	6	20	10	0.00	0.07	0.09	11.49	1.73	-11.45	0.03	2.63	3.60
1489	6	20	15	0.00	0.07	0.11	11.49	2.77	-11.51	0.03	2.60	3.63

* Indicates model was close to heave stop

TABLE A1.301.1 - STABILITY DATA IN WIND AXES WITH AIR TARES

30 deg Deadrise, L/R = 0.000, Cv = 1.5

RUN	Trim deg	Roll deg	Yaw deg	Speed fps	X lb	Y lb	Z lb	K lb-ft	M lb-ft	N lb-ft	Heave in	TD in
1642	-2	-10	0	7.36	1.57	0.30	11.49	0.18	4.38	0.23	1.54	1.76
1646	-2	-10	5	7.35	1.78	1.39	11.49	-0.32	4.59	2.29	1.47	1.83
1649	-2	-10	10	7.35	2.48	3.29	11.49	-0.89	5.06	5.00	1.27	2.03
1652	-2	-10	15	7.34	4.10	6.41	11.49	-1.83	5.90	8.83	0.98	2.32
1589	-2	0	0	7.35	1.51	-0.04	11.49	0.04	4.30	0.00	1.57	1.79
1594	-2	0	5	7.35	1.71	0.96	11.49	-0.42	4.33	1.96	1.49	1.87
1608	-2	0	10	7.45	2.60	3.38	11.49	-1.06	5.00	4.60	1.22	2.14
1611 *	-2	0	15	7.34	4.48	7.12	11.49	-1.81	5.48	8.99	0.82	2.54
1615	-2	10	0	7.34	1.60	0.00	11.49	-0.14	4.11	-0.44	1.53	1.77
1619	-2	10	5	7.34	1.74	0.95	11.49	-0.66	4.13	1.47	1.44	1.86
1622	-2	10	10	7.34	2.51	3.15	11.49	-1.39	4.95	4.23	1.21	2.09
1625 *	-2	10	15	7.32	4.91	7.67	11.49	-2.53	7.02	8.84	0.70	2.60
1629	-2	20	0	7.46	1.43	-0.16	11.49	-0.18	3.89	-0.53	1.69	1.42
1633	-2	20	5	7.38	1.68	0.86	11.49	-0.79	3.92	1.06	1.57	1.54
1636	-2	20	10	7.37	2.54	2.82	11.49	-1.58	4.40	3.69	1.28	1.83
1639 *	-2	20	15	7.34	4.72	6.70	11.49	-2.66	6.25	9.05	0.71	2.40
1572	0	-10	0	7.36	1.24	0.36	11.49	0.26	0.43	0.17	1.81	2.28
1576	0	-10	5	7.35	1.43	1.05	11.49	0.19	0.61	1.29	1.76	2.33
1580	0	-10	10	7.34	1.99	2.74	11.49	-0.03	1.07	2.72	1.63	2.46
1584	0	-10	15	7.34	3.35	5.73	11.49	-0.61	2.17	5.15	1.35	2.74
1512	0	0	0	7.35	1.24	-0.27	11.49	0.13	0.62	0.01	1.69	2.46
1528	0	0	5	7.38	1.36	0.85	11.49	0.02	0.70	1.14	1.75	2.40
1533	0	0	10	7.36	2.02	2.73	11.49	-0.24	1.47	2.37	1.57	2.58
1536	0	0	15	7.40	3.68	6.54	11.49	-0.50	2.08	4.47	1.23	2.92
1540	0	10	0	7.35	1.12	-0.16	11.49	-0.10	0.22	-0.52	1.82	2.27
1544	0	10	5	7.35	1.33	0.85	11.49	-0.25	0.53	1.02	1.77	2.32
1548	0	10	10	7.34	2.01	2.74	11.49	-0.61	1.37	2.48	1.60	2.49
1551	0	10	15	7.32	3.56	6.03	11.49	-1.22	3.09	4.22	1.24	2.85
1554	0	20	0	7.34	1.20	0.09	11.49	-0.23	0.13	-0.27	1.92	1.98
1558	0	20	5	7.38	1.27	0.67	11.49	-0.35	0.30	0.68	1.87	2.03
1562	0	20	10	7.36	1.87	2.47	11.49	-0.77	1.05	2.18	1.67	2.23
1566	0	20	15	7.36	3.53	5.70	11.49	-1.56	3.08	4.61	1.27	2.63
1375	3	-10	0	7.45	1.19	0.12	11.49	0.41	-5.38	0.20	2.27	2.99
1378	3	-10	5	7.38	1.34	1.26	11.49	0.80	-4.90	0.21	2.24	3.02
1383	3	-10	10	7.36	1.95	3.07	11.49	1.03	-3.96	-0.07	2.11	3.15
1387	3	-10	15	7.34	3.02	5.47	11.49	1.07	-2.89	-0.18	1.96	3.30
1302	3	0	0	7.32	1.16	0.23	11.49	0.10	-5.46	0.00	2.00	3.32
1303	3	0	0	7.31	1.20	0.29	11.49	0.10	-5.48	0.02	1.97	3.35
1308	3	0	0	7.31	1.17	0.06	11.49	0.13	-5.52	0.01	1.98	3.34
1310	3	0	5	7.34	1.34	1.14	11.49	0.61	-5.24	0.23	1.98	3.34
1314	3	0	10	7.35	1.85	2.75	11.49	0.89	-4.48	0.12	1.88	3.44
1319	3	0	15	7.35	3.26	5.96	11.49	0.96	-2.95	-0.19	1.62	3.70

* Indicates model was close to heave stop

TABLE A1.301.2 - STABILITY DATA IN WIND AXES WITH AIR TARES

30 deg Deadrise, L/R = 0.000, Cv = 1.5

RUN	Trim deg	Roll deg	Yaw deg	Speed fps	X lb	Y lb	Z lb	K lb-ft	M lb-ft	N lb-ft	Heave in	TD in
1325	3	10	0	7.33	1.17	0.23	11.49	-0.15	-5.35	-0.18	2.09	3.17
1329	3	10	5	7.34	1.26	0.81	11.49	0.33	-5.27	-0.09	2.05	3.21
1333	3	10	10	7.33	1.79	2.57	11.49	0.57	-4.66	-0.04	1.91	3.35
1337	3	10	15	7.33	3.04	5.50	11.49	0.64	-3.42	-0.20	1.69	3.57
1343	3	20	0	7.34	1.22	0.16	11.49	-0.27	-5.22	-0.20	2.13	2.94
1360	3	20	5	7.45	1.27	0.80	11.49	0.16	-5.24	-0.30	2.29	2.78
1364	3	20	10	7.35	1.68	2.08	11.49	0.42	-4.63	-0.48	2.16	2.91
1368	3	20	15	7.34	2.79	4.79	11.49	0.16	-2.92	-0.79	1.90	3.17
1370	3	20	15	7.43	2.85	4.81	11.49	0.16	-2.81	-0.83	1.89	3.18
1495	6	-10	0	7.44	1.68	0.16	11.49	0.45	-9.36	0.19	2.64	3.78
1499	6	-10	5	7.37	1.79	1.25	11.49	1.19	-8.85	-0.67	2.61	3.81
1503	6	-10	10	7.35	2.33	3.05	11.49	1.62	-8.00	-2.03	2.55	3.87
1507	6	-10	15	7.35	3.62	6.15	11.49	1.86	-6.94	-4.33	2.36	4.06
1406	6	0	0	7.34	1.55	-0.07	11.49	0.17	-9.60	0.03	2.73	3.75
1410	6	0	5	7.43	1.81	1.14	11.49	0.98	-9.42	-0.74	2.71	3.77
1441	6	0	10	7.40	2.17	2.70	11.49	1.54	-8.55	-1.83	2.75	3.73
1456	6	0	15	7.45	3.32	5.33	11.49	1.85	-7.54	-3.74	2.51	3.97
1461	6	10	0	7.38	1.64	0.10	11.49	-0.12	-9.41	-0.19	2.66	3.76
1465	6	10	5	7.36	1.74	1.12	11.49	0.69	-9.25	-0.95	2.68	3.74
1469	6	10	10	7.35	2.22	2.85	11.49	1.33	-8.86	-2.03	2.59	3.83
1473	6	10	15	7.34	3.30	5.41	11.49	1.60	-7.86	-3.57	2.41	4.01
1478	6	20	0	7.46	1.67	0.05	11.49	-0.28	-9.08	-0.03	2.71	3.52
1482	6	20	5	7.38	1.77	1.50	11.49	0.37	-9.01	-1.14	2.68	3.55
1486	6	20	10	7.37	2.21	2.91	11.49	0.96	-8.25	-2.57	2.63	3.60

* Indicates model was close to heave stop

TABLE A1.303.1 - STABILITY DATA IN WIND AXES WITH AIR TARES

30 deg Deadrise, L/R = 0.000, Cv = 3

RUN	Trim deg	Roll deg	Yaw deg	Speed fps	X lb	Y lb	Z lb	K lb-ft	M lb-ft	N lb-ft	Heave in	TD in
1643	-2	-10	0	14.72	5.81	1.16	11.49	0.35	-0.04	1.70	1.39	1.91
1647	-2	-10	5	14.71	7.25	6.49	11.49	-0.16	0.98	11.27	1.08	2.22
1650 *	-2	-10	10	14.67	11.30	17.77	11.49	-1.06	2.47	22.46	0.74	2.56
1590	-2	0	0	14.71	5.62	-0.19	11.49	0.12	-0.60	-0.59	1.42	1.94
1595	-2	0	5	14.71	6.99	5.22	11.49	-0.45	0.38	8.95	1.11	2.25
1609 *	-2	0	10	14.74	11.32	18.14	11.49	-1.22	2.57	20.40	0.71	2.65
1616	-2	10	0	14.71	5.71	-1.55	11.49	-0.18	0.08	-3.17	1.36	1.94
1620	-2	10	5	14.71	6.71	3.67	11.49	-0.70	0.46	5.68	1.08	2.22
1623 *	-2	10	10	14.67	11.01	16.79	11.49	-1.41	2.07	17.18	0.72	2.58
1630	-2	20	0	14.79	5.80	-1.58	11.49	-0.28	2.12	-4.72	1.51	1.60
1634	-2	20	5	14.72	7.66	3.06	11.49	-1.24	3.44	2.33	1.10	2.01
1637 *	-2	20	10	14.69	11.44	14.43	11.49	-2.46	6.01	13.42	0.72	2.39
1573	0	-10	0	14.72	3.30	0.04	11.49	0.29	1.52	0.90	2.04	2.05
1577	0	-10	5	14.72	4.47	4.17	11.49	-0.07	2.22	3.36	1.93	2.16
1581	0	-10	10	14.71	7.03	11.84	11.49	-0.62	3.01	7.28	1.76	2.33
1585	0	-10	15	14.69	8.23	14.68	11.49	-1.22	4.65	7.37	2.31	1.78
1513	0	0	0	14.72	3.27	-0.01	11.49	0.08	2.49	0.00	1.91	2.24
1530	0	0	5	14.74	4.30	3.86	11.49	-0.20	3.42	3.79	1.88	2.27
1534	0	0	10	14.69	8.48	14.34	11.49	-1.05	5.46	5.73	1.24	2.91
1541	0	10	0	14.71	3.25	-0.05	11.49	-0.10	1.18	-0.90	2.04	2.05
1545	0	10	5	14.71	4.28	3.89	11.49	-0.44	3.86	3.36	1.85	2.24
1549	0	10	10	14.69	8.33	13.81	11.49	-1.38	6.76	6.79	1.24	2.85
1555	0	20	0	14.79	3.42	0.11	11.49	-0.22	0.42	-0.97	2.17	1.73
1559	0	20	5	14.74	4.12	3.82	11.49	-0.56	2.76	2.08	1.91	1.99
1563	0	20	10	14.71	8.20	13.53	11.49	-1.45	5.31	10.33	1.41	2.49
1567	0	20	15	14.67	13.33	23.56	11.49	-3.99	13.58	11.51	1.28	2.62
1376	3	-10	0	14.85	2.62	0.27	11.49	0.47	-4.12	0.94	2.69	2.57
1380	3	-10	5	14.79	3.13	3.28	11.49	0.73	-2.78	0.21	2.65	2.61
1668	3	-10	5	14.79	3.18	3.08	11.49	0.79	-2.89	0.25	2.59	2.67
1384	3	-10	10	14.77	5.47	10.58	11.49	0.28	0.56	-2.35	2.42	2.84
1388	3	-10	15	14.77	3.53	5.95	11.49	2.53	-7.45	-4.39	3.53	1.73
1305	3	0	0	14.77	2.48	0.39	11.49	0.10	-4.80	0.04	2.46	2.86
1654	3	0	0	14.72	2.50	-0.30	11.49	0.52	-4.89	0.02	2.59	2.73
1311	3	0	5	14.77	3.10	3.25	11.49	0.63	-4.07	0.15	2.41	2.91
1655	3	0	5	14.72	3.19	3.19	11.49	0.89	-4.16	0.25	2.54	2.78
1316	3	0	10	14.74	5.45	10.35	11.49	0.36	-0.95	-1.38	2.20	3.12
1656	3	0	10	14.72	5.60	10.31	11.49	0.65	-0.69	-0.86	2.28	3.04
1320	3	0	15	14.71	12.09	25.98	11.49	-1.44	6.53	-2.73	1.65	3.67
1657	3	0	15	14.67	12.71	27.12	11.49	-1.45	6.81	-1.53	1.65	3.67

* Indicates model was close to heave stop

TABLE A1.303.2 - STABILITY DATA IN WIND AXES WITH AIR TARES

30 deg Deadrise, L/R = 0.000, Cv = 3

RUN	Trim deg	Roll deg	Yaw deg	Speed fps	X lb	Y lb	Z lb	K lb-ft	M lb-ft	N lb-ft	Heave in	TD in
1326	3	10	0	14.74	2.62	-0.23	11.49	-0.18	-4.34	-0.81	2.51	2.75
1660	3	10	0	14.74	2.68	-0.08	11.49	-0.06	-4.29	-0.89	2.62	2.64
1330	3	10	5	14.74	2.88	3.05	11.49	0.25	-4.40	-0.94	2.48	2.78
1659	3	10	5	14.74	2.82	2.40	11.49	0.36	-4.41	-1.04	2.58	2.68
1334	3	10	10	14.72	4.57	8.42	11.49	0.33	-2.86	-1.53	2.33	2.93
1661	3	10	10	14.72	4.63	8.02	11.49	0.66	-2.72	-1.40	2.47	2.79
1338	3	10	15	14.71	9.43	19.76	11.49	-0.90	2.64	-2.33	1.97	3.29
1662	3	10	15	14.69	10.34	21.36	11.49	-1.19	4.06	-1.91	1.96	3.30
1344	3	20	0	14.76	2.59	0.11	11.49	-0.33	-3.55	-1.04	2.56	2.51
1664	3	20	0	14.74	2.68	-0.01	11.49	-0.44	-3.55	-1.26	2.69	2.38
1361	3	20	5	14.77	2.76	2.31	11.49	-0.04	-3.39	-1.94	2.77	2.30
1665	3	20	5	14.74	2.85	2.42	11.49	0.08	-3.20	-1.99	2.68	2.39
1365	3	20	10	14.77	3.72	6.10	11.49	0.14	-3.70	-3.72	2.83	2.24
1666	3	20	10	14.72	3.83	6.33	11.49	0.23	-3.41	-3.62	2.73	2.34
1369	3	20	15	14.74	6.56	13.00	11.49	-0.19	-2.60	-6.35	2.69	2.38
1371	3	20	15	14.81	6.54	12.97	11.49	-0.20	-2.65	-6.50	2.70	2.37
1667	3	20	15	14.71	6.71	13.18	11.49	-0.05	-2.13	-6.03	2.61	2.46
1496	6	-10	0	14.79	2.24	0.11	11.49	0.49	-9.50	0.33	3.64	2.78
1500	6	-10	5	14.74	2.76	2.72	11.49	1.13	-8.20	-1.89	3.50	2.92
1504	6	-10	10	14.72	4.19	7.62	11.49	1.15	-7.25	-7.12	3.41	3.01
1508	6	-10	15	14.71	9.02	18.90	11.49	0.14	-3.63	-15.18	2.89	3.53
1407	6	0	0	14.76	2.18	-0.15	11.49	0.19	-10.09	0.06	3.79	2.69
1411	6	0	5	14.81	2.68	2.70	11.49	1.00	-9.83	-2.35	3.73	2.75
1442	6	0	10	14.76	3.80	6.44	11.49	1.38	-8.48	-5.11	3.63	2.85
1457	6	0	15	14.77	7.69	15.54	11.49	0.59	-5.52	-12.05	3.04	3.44
1462	6	10	0	14.74	2.29	-0.26	11.49	-0.05	-9.76	-0.47	3.64	2.78
1466	6	10	5	14.74	2.46	2.74	11.49	0.69	-10.47	-2.95	3.78	2.64
1470	6	10	10	14.72	3.46	5.78	11.49	1.43	-10.64	-6.26	3.77	2.65
1474	6	10	15	14.71	5.74	10.99	11.49	1.68	-9.82	-10.65	3.56	2.86
1479	6	20	0	14.81	2.38	0.20	11.49	-0.35	-8.22	-0.57	3.61	2.62
1483	6	20	5	14.76	2.43	2.48	11.49	0.38	-9.80	-2.89	3.86	2.37
1487	6	20	10	14.74	2.89	4.43	11.49	1.28	-11.04	-5.83	4.00	2.23
1491	6	20	15	14.77	3.98	6.79	11.49	2.04	-11.64	-9.35	4.11	2.12

* Indicates model was close to heave stop

TABLE A1.304.1 - STABILITY DATA IN WIND AXES WITH AIR TARES

30 deg Deadrise, L/R = 0.000, Cv = 4

RUN	Trim deg	Roll deg	Yaw deg	Speed fps	X lb	Y lb	Z lb	K lb-ft	M lb-ft	N lb-ft	Heave in	TD in
1644	* -2	-10	0	19.62	11.32	1.89	11.49	0.63	-3.15	3.22	0.68	2.62
1592	* -2	0	0	19.59	10.92	-0.79	11.49	0.22	-5.27	-1.46	0.70	2.66
1596	* -2	0	5	19.59	12.85	10.89	11.49	-0.51	-3.16	20.32	0.73	2.63
1617	* -2	10	0	19.62	11.38	-2.75	11.49	-0.26	-2.74	-6.17	0.65	2.65
1631	* -2	20	0	19.65	11.08	-3.17	11.49	-0.45	0.18	-10.46	0.66	2.45
1574	0	-10	0	19.65	5.87	0.07	11.49	0.14	5.30	1.31	1.93	2.16
1578	0	-10	5	19.62	9.01	7.61	11.49	-0.51	5.89	7.39	1.60	2.49
1582	0	-10	10	19.62	11.53	19.54	11.49	-1.19	5.24	13.03	1.89	2.20
1586	0	-10	15	19.65	3.68	5.52	11.49	0.30	-0.57	1.40	3.63	0.46
1515	0	0	0	19.65	5.61	-0.04	11.49	0.09	6.34	-0.05	1.86	2.29
1531	0	0	5	19.65	8.23	6.81	11.49	-0.66	8.44	6.79	1.64	2.51
1542	0	10	0	19.62	5.81	0.17	11.49	0.02	4.78	-1.21	1.94	2.15
1546	0	10	5	19.62	7.72	6.86	11.49	-0.79	9.77	6.98	1.73	2.36
1556	0	20	0	19.68	6.56	0.16	11.49	-0.13	2.66	-1.18	2.05	1.85
1560	0	20	5	19.65	7.69	7.05	11.49	-0.89	9.16	5.70	1.75	2.15
1564	0	20	10	19.62	12.60	20.25	11.49	-3.00	15.45	14.32	1.59	2.31
1568	0	20	15	19.53	22.56	39.78	11.49	-6.51	24.04	21.47	1.35	2.55
1377	3	-10	0	19.81	3.81	0.67	11.49	0.45	-3.32	0.76	2.93	2.33
1381	3	-10	5	19.78	4.43	4.64	11.49	0.64	-1.45	-0.14	2.91	2.35
1385	3	-10	10	19.75	7.39	14.21	11.49	-0.05	2.66	-4.95	2.79	2.47
1389	3	-10	15	19.78	3.93	7.16	11.49	3.40	-11.68	-7.65	4.02	1.24
1306	3	0	0	19.72	3.68	0.15	11.49	0.13	-4.54	0.02	2.73	2.59
1312	3	0	5	19.75	4.44	5.05	11.49	0.55	-3.55	-0.70	2.69	2.63
1317	3	0	10	19.32	7.78	15.28	11.49	-0.03	0.79	-3.51	2.46	2.86
1322	3	0	10	19.72	7.94	15.44	11.49	0.01	1.02	-3.40	2.47	2.85
1321	3	0	15	19.62	18.34	40.43	11.49	-3.31	14.08	-7.28	1.93	3.39

* Indicates model was close to heave stop

TABLE A1.304.2 - STABILITY DATA IN WIND AXES WITH AIR TARES

30 deg Deadrise, L/R = 0.000, Cv = 4

RUN	Trim deg	Roll deg	Yaw deg	Speed fps	X lb	Y lb	Z lb	K lb-ft	M lb-ft	N lb-ft	Heave in	TD in
1327	3	10	0	19.72	3.82	-0.32	11.49	-0.22	-3.36	-0.69	2.72	2.54
1331	3	10	5	19.72	4.16	4.33	11.49	0.35	-5.13	-2.17	2.80	2.46
1335	3	10	10	19.68	6.58	12.52	11.49	0.43	-3.89	-4.79	2.65	2.61
1339	3	10	15	19.65	15.30	32.72	11.49	-2.04	7.26	-3.91	2.07	3.19
1340	3	10	15	19.68	15.30	32.66	11.49	-2.02	7.36	-3.78	2.07	3.19
1345	3	20	0	19.75	3.65	-0.12	11.49	-0.41	-1.92	-1.08	2.79	2.28
1362	3	20	5	19.78	3.66	2.82	11.49	-0.01	-4.36	-2.55	3.15	1.92
1366	3	20	10	19.75	5.07	7.86	11.49	0.40	-6.18	-6.48	3.20	1.87
1372	3	20	15	19.78	8.53	16.33	11.49	0.28	-6.79	-13.03	3.17	1.90
1497	6	-10	0	19.72	2.61	0.76	11.49	0.45	-12.61	-0.75	4.40	2.02
1501	6	-10	5	19.68	3.12	3.84	11.49	1.23	-11.55	-4.45	4.33	2.09
1505	6	-10	10	19.65	4.25	7.60	11.49	1.71	-11.16	-8.89	4.33	2.09
1509	6	-10	15	19.65	8.08	16.24	11.49	1.32	-9.69	-19.54	4.07	2.35
1408	6	0	0	19.75	2.48	-0.19	11.49	0.28	-13.38	0.09	4.49	1.99
1412	6	0	5	19.78	3.05	3.51	11.49	1.08	-13.28	-4.63	4.48	2.00
1439	6	0	5	19.81	2.98	3.39	11.49	1.14	-13.62	-4.70	4.55	1.93
1443	6	0	10	19.68	4.19	7.77	11.49	1.74	-13.00	-9.83	4.52	1.96
1458	6	0	15	19.68	6.96	13.92	11.49	1.93	-12.38	-16.65	4.22	2.26
1463	6	10	0	19.68	2.58	-0.99	11.49	0.06	-12.98	0.57	4.43	1.99
1467	6	10	5	19.65	2.80	2.60	11.49	0.83	-13.50	-3.66	4.45	1.97
1471	6	10	10	19.65	3.86	6.38	11.49	1.60	-13.81	-8.90	4.45	1.97
1475	6	10	15	19.65	6.01	11.63	11.49	1.98	-13.92	-15.72	4.43	1.99
1480	6	20	0	19.72	2.59	-0.74	11.49	-0.20	-11.81	0.67	4.46	1.77
1484	6	20	5	19.68	2.38	1.52	11.49	0.71	-13.16	-2.33	4.65	1.58
1488	6	20	10	19.68	2.96	3.75	11.49	1.61	-13.93	-5.86	4.69	1.54
1492	6	20	15	19.68	4.13	6.50	11.49	2.34	-14.17	-10.12	4.69	1.54

* Indicates model was close to heave stop

TABLE A1.310.1 - STABILITY DATA IN WIND AXES WITH AIR TARES

30 deg Deadrise, L/R = 0.117, Cv = 0

RUN	Trim deg	Roll deg	Yaw deg	Speed fps	X lb	Y lb	Z lb	K lb-ft	M lb-ft	N lb-ft	Heave in	TD in
563	0	-10	-15	0.00	0.02	0.07	11.49	-0.54	-3.09	0.00	1.82	2.27
560	0	-10	-10	0.00	0.04	0.09	11.49	-0.26	-3.09	0.01	1.82	2.27
555	0	-10	-5	0.00	0.05	0.08	11.49	0.01	-3.11	0.00	1.81	2.28
527	0	-10	0	0.00	0.03	0.12	11.49	0.27	-3.07	0.03	1.89	2.20
548	0	-10	0	0.00	0.01	0.01	11.49	0.31	-3.09	0.03	1.87	2.22
531	0	-10	5	0.00	0.01	0.11	11.49	0.54	-3.04	0.04	1.88	2.21
535	0	-10	10	0.00	0.03	0.16	11.49	0.79	-2.95	0.06	1.89	2.20
551	0	-10	15	0.00	0.04	0.12	11.49	1.06	-2.91	0.04	1.83	2.26
463	0	0	-15	0.00	0.04	0.08	11.49	-0.72	-2.84	0.02	1.83	2.32
460	0	0	-10	0.00	0.06	0.08	11.49	-0.47	-2.88	0.01	1.84	2.31
456	0	0	-5	0.00	0.05	0.07	11.49	-0.21	-2.94	0.00	1.81	2.34
77	0	0	0	0.00	0.04	0.09	11.49	0.04	-2.73	0.01	1.97	2.18
441	0	0	0	0.00	0.10	0.00	11.49	0.05	-2.89	0.02	1.84	2.31
476	0	0	0	0.00	0.06	0.49	11.49	0.05	-2.90	-0.77	1.85	2.30
446	0	0	5	0.00	0.04	0.12	11.49	0.30	-2.81	0.04	1.86	2.29
451	0	0	10	0.00	0.03	0.14	11.49	0.54	-2.76	0.04	1.87	2.28
454	0	0	15	0.00	0.04	0.11	11.49	0.80	-2.85	0.03	1.81	2.34
495	0	10	-15	0.00	0.02	0.09	11.49	-0.97	-2.93	0.01	1.91	2.18
491	0	10	-10	0.00	0.04	0.08	11.49	-0.72	-3.00	0.01	1.88	2.21
487	0	10	-5	0.00	0.06	0.08	11.49	-0.46	-3.00	0.00	1.87	2.22
466	0	10	0	0.00	0.04	0.10	11.49	-0.20	-3.10	0.02	1.91	2.18
478	0	10	5	0.00	0.05	0.12	11.49	0.09	-3.05	0.03	1.90	2.19
482	0	10	10	0.00	0.05	0.14	11.49	0.35	-3.01	0.06	1.91	2.18
485	0	10	15	0.00	0.06	0.10	11.49	0.60	-3.03	0.05	1.88	2.21
522	0	20	-15	0.00	-0.00	0.08	11.49	-1.19	-3.12	0.00	1.96	1.94
518	0	20	-10	0.00	0.04	0.10	11.49	-0.91	-3.18	0.01	1.96	1.94
514	0	20	-5	0.00	0.08	0.10	11.49	-0.59	-3.01	-0.07	1.95	1.95
500	0	20	0	0.00	0.03	0.04	11.49	-0.31	-3.16	0.01	2.01	1.89
504	0	20	5	0.00	0.05	0.14	11.49	-0.04	-3.26	0.03	1.96	1.94
508	0	20	10	0.00	0.05	0.11	11.49	0.24	-3.20	0.03	1.97	1.93
512	0	20	15	0.00	0.06	0.12	11.49	0.52	-3.27	0.03	1.95	1.95
275	3	-10	-15	0.00	0.07	0.28	11.49	-1.72	-7.56	0.03	2.17	3.09
271	3	-10	-10	0.00	0.05	0.19	11.49	-1.07	-7.88	0.01	2.12	3.14
266	3	-10	-5	0.00	0.03	0.13	11.49	-0.39	-8.08	0.01	2.10	3.16
245	3	-10	0	0.00	0.03	0.11	11.49	0.31	-7.98	0.00	2.14	3.12
250	3	-10	5	0.00	0.03	0.13	11.49	1.03	-8.05	0.00	2.09	3.17
256	3	-10	10	0.00	0.03	0.13	11.49	1.74	-7.99	0.02	2.09	3.17
260	3	-10	15	0.00	0.03	0.14	11.49	2.43	-7.84	0.00	2.08	3.18
128	3	0	-15	0.00	0.05	0.15	11.49	-2.01	-7.87	0.01	2.21	3.11
123	3	0	-10	0.00	0.05	0.12	11.49	-1.35	-8.18	0.02	2.17	3.15
119	3	0	-5	0.00	0.03	0.12	11.49	-0.63	-8.20	0.00	2.15	3.17
80	3	0	0	0.00	0.06	0.05	11.49	0.08	-8.16	0.02	2.19	3.13
85	3	0	5	0.00	0.05	0.13	11.49	0.81	-8.17	0.02	2.17	3.15
110	3	0	10	0.00	0.05	0.11	11.49	1.54	-8.18	0.03	2.16	3.16
114	3	0	15	0.00	0.07	0.10	11.49	2.22	-7.93	0.03	2.17	3.15

* Indicates model was close to heave stop

TABLE A1.310.2 - STABILITY DATA IN WIND AXES WITH AIR TARES

30 deg Deadrise, L/R = 0.117, Cv = 0

RUN	Trim deg	Roll deg	Yaw deg	Speed fps	X lb	Y lb	Z lb	K lb-ft	M lb-ft	N lb-ft	Heave in	TD in
190	3	10	-15	0.00	0.09	0.36	11.49	-2.12	-7.40	0.08	2.21	3.05
183	3	10	-10	0.00	0.10	0.51	11.49	-1.36	-7.06	0.13	2.32	2.94
179	3	10	-5	0.00	0.12	0.26	11.49	-0.81	-7.78	0.03	2.18	3.08
137	3	10	0	0.00	0.10	0.24	11.49	-0.14	-7.78	0.04	2.25	3.01
169	3	10	0	0.00	0.03	0.10	11.49	-0.13	-8.12	0.00	2.20	3.06
145	3	10	5	0.00	0.05	0.15	11.49	0.56	-8.06	0.02	2.23	3.03
149	3	10	10	0.00	0.05	0.15	11.49	1.28	-8.04	0.03	2.23	3.03
239	3	20	-15	0.00	0.11	0.38	11.49	-2.21	-7.30	0.06	2.24	2.83
234	3	20	-10	0.00	0.08	0.24	11.49	-1.64	-7.80	0.03	2.19	2.88
230	3	20	-5	0.00	0.05	0.18	11.49	-0.98	-8.08	0.01	2.15	2.92
196	3	20	0	0.00	0.04	0.14	11.49	-0.27	-8.20	0.00	2.23	2.84
203	3	20	5	0.00	0.03	0.15	11.49	0.45	-8.24	0.03	2.22	2.85
208	3	20	10	0.00	0.03	0.14	11.49	1.17	-8.19	0.01	2.22	2.85
209	3	20	10	0.00	0.03	0.12	11.49	1.17	-8.21	0.02	2.22	2.85
213	3	20	15	0.00	0.02	0.14	11.49	1.90	-8.12	0.01	2.21	2.86
227	3	20	15	0.00	0.04	0.14	11.49	1.87	-8.06	0.01	2.18	2.89
436	6	-10	-15	0.00	0.10	0.49	11.49	-2.35	-10.00	0.11	2.57	3.85
432	6	-10	-10	0.00	0.08	0.30	11.49	-1.56	-10.77	0.05	2.49	3.93
428	6	-10	-5	0.00	0.06	0.27	11.49	-0.63	-11.08	0.04	2.44	3.98
403	6	-10	0	0.00	0.12	0.93	11.49	0.29	-9.21	0.33	2.82	3.60
407	6	-10	5	0.00	0.06	0.15	11.49	1.32	-11.21	0.05	2.56	3.86
411	6	-10	10	0.00	0.05	0.16	11.49	2.30	-11.08	0.05	2.56	3.86
424	6	-10	15	0.00	0.05	0.10	11.49	3.25	-10.82	0.03	2.46	3.96
323	6	0	-15	0.00	0.04	0.27	11.49	-2.74	-10.69	0.06	2.51	3.97
317	6	0	-10	0.00	0.05	0.29	11.49	-1.80	-10.89	0.06	2.49	3.99
311	6	0	-5	0.00	0.04	0.19	11.49	-0.85	-11.14	0.04	2.47	4.01
289	6	0	0	0.00	0.07	0.23	11.49	0.13	-10.89	0.06	2.57	3.91
295	6	0	5	0.00	0.04	0.15	11.49	1.12	-11.30	0.04	2.48	4.00
298	6	0	10	0.00	0.06	0.16	11.49	2.11	-11.22	0.06	2.46	4.02
302	6	0	15	0.00	0.05	0.14	11.49	3.08	-11.01	0.04	2.46	4.02
308	6	0	15	0.00	0.04	0.14	11.49	3.08	-11.02	0.03	2.43	4.05
364	6	10	-15	0.00	0.07	0.25	11.49	-2.93	-10.64	0.05	2.58	3.84
359	6	10	-10	0.00	0.06	0.18	11.49	-2.03	-11.05	0.01	2.54	3.88
346	6	10	-5	0.00	0.05	0.14	11.49	-1.09	-11.38	0.02	2.45	3.97
355	6	10	-5	0.00	0.07	0.17	11.49	-1.07	-11.20	0.01	2.53	3.89
329	6	10	0	0.00	0.05	0.10	11.49	-0.09	-11.37	0.02	2.49	3.93
334	6	10	5	0.00	0.05	0.14	11.49	0.91	-11.38	0.06	2.45	3.97
338	6	10	10	0.00	0.06	0.14	11.49	1.90	-11.29	0.06	2.44	3.98
342	6	10	15	0.00	0.05	0.15	11.49	2.89	-11.12	0.06	2.44	3.98
369	6	10	15	0.00	0.07	0.15	11.49	2.87	-11.04	0.04	2.52	3.90
397	6	20	-15	0.00	0.04	0.16	11.49	-3.19	-10.93	0.00	2.62	3.61
393	6	20	-10	0.00	0.05	0.13	11.49	-2.21	-11.11	0.00	2.63	3.60
389	6	20	-5	0.00	0.03	0.14	11.49	-1.24	-11.30	0.01	2.60	3.63
372	6	20	0	0.00	0.06	0.15	11.49	-0.26	-11.34	0.02	2.59	3.64
376	6	20	5	0.00	0.00	0.13	11.49	0.75	-11.42	0.02	2.57	3.66
381	6	20	10	0.00	0.05	0.14	11.49	1.73	-11.25	0.04	2.58	3.65
385	6	20	15	0.00	0.05	0.14	11.49	2.71	-11.09	0.04	2.58	3.65

* Indicates model was close to heave stop

TABLE A1.311.1 - STABILITY DATA IN WIND AXES WITH AIR TARES

30 deg Deadrise, L/R = 0.117, Cv = 1.5

RUN	Trim deg	Roll deg	Yaw deg	Speed fps	X lb	Y lb	Z lb	K lb-ft	M lb-ft	N lb-ft	Heave in	TD in	
564	*	0	-10	-15	7.35	4.18	-9.51	11.49	1.08	2.35	-7.81	0.68	3.41
561		0	-10	-10	7.36	2.16	-4.97	11.49	0.60	1.03	-4.03	1.24	2.85
556		0	-10	-5	7.37	1.41	-2.98	11.49	0.36	0.51	-2.09	1.46	2.63
528		0	-10	0	7.37	1.18	-1.97	11.49	0.19	0.59	-0.61	1.58	2.51
532		0	-10	5	7.37	1.36	-1.18	11.49	0.05	1.07	0.31	1.53	2.56
536		0	-10	10	7.37	1.97	0.47	11.49	-0.23	1.76	1.39	1.36	2.73
550		0	-10	15	7.38	3.36	3.32	11.49	-0.91	3.06	3.46	1.01	3.08
464	*	0	0	-15	7.35	4.20	-9.97	11.49	0.44	1.48	-7.87	0.85	3.30
461		0	0	-10	7.36	2.26	-5.33	11.49	0.33	1.23	-4.18	1.23	2.92
457		0	0	-5	7.36	1.54	-3.12	11.49	0.08	0.84	-2.28	1.43	2.72
78		0	0	0	7.38	1.21	-2.05	11.49	-0.05	0.68	-0.84	1.64	2.51
443		0	0	0	7.38	1.31	-2.11	11.49	-0.03	0.75	-0.86	1.54	2.61
448		0	0	5	7.38	1.39	-1.17	11.49	-0.15	1.26	0.17	1.51	2.64
452		0	0	10	7.37	2.04	0.56	11.49	-0.50	2.27	1.06	1.31	2.84
455	*	0	0	15	7.37	4.14	4.77	11.49	-1.27	4.27	2.94	0.77	3.38
496		0	10	-15	7.36	3.64	-8.61	11.49	0.57	1.78	-7.65	1.05	3.04
492		0	10	-10	7.37	2.18	-5.28	11.49	0.17	1.16	-4.33	1.30	2.79
488		0	10	-5	7.38	1.51	-3.19	11.49	-0.08	0.73	-2.33	1.48	2.61
467		0	10	0	7.36	1.25	-2.03	11.49	-0.22	0.66	-0.99	1.58	2.51
479		0	10	5	7.38	1.32	-1.31	11.49	-0.40	1.11	0.07	1.53	2.56
483		0	10	10	7.36	1.96	0.33	11.49	-0.84	2.19	1.17	1.34	2.75
486	*	0	10	15	7.37	3.72	3.84	11.49	-1.77	4.57	2.59	0.82	3.27
523		0	20	-15	7.38	3.90	-8.42	11.49	0.93	3.01	-7.85	0.99	2.91
519		0	20	-10	7.37	2.12	-4.78	11.49	0.08	1.30	-4.20	1.42	2.48
515		0	20	-5	7.37	1.55	-3.02	11.49	-0.20	0.81	-2.40	1.56	2.34
501		0	20	0	7.39	1.26	-2.21	11.49	-0.39	0.41	-1.08	1.65	2.25
505		0	20	5	7.38	1.31	-1.37	11.49	-0.55	0.85	-0.17	1.61	2.29
509		0	20	10	7.37	1.84	0.03	11.49	-1.03	1.96	0.95	1.40	2.50
513		0	20	15	7.37	3.51	3.25	11.49	-2.05	4.49	2.88	0.95	2.95
276		3	-10	-15	7.36	2.69	-6.05	11.49	-0.46	-3.00	-0.61	1.76	3.50
272		3	-10	-10	7.36	1.71	-3.90	11.49	-0.47	-4.60	-0.73	1.86	3.40
267		3	-10	-5	7.35	1.32	-2.44	11.49	-0.16	-5.11	-0.54	1.94	3.32
246		3	-10	0	7.38	1.19	-1.61	11.49	0.27	-5.01	-0.38	1.96	3.30
249		3	-10	5	7.37	1.40	-0.67	11.49	0.64	-4.41	-0.48	1.91	3.35
251		3	-10	5	7.37	1.39	-0.68	11.49	0.64	-4.41	-0.49	1.92	3.34
253		3	-10	5	7.37	1.38	-0.66	11.49	0.63	-4.38	-0.49	1.92	3.34
257		3	-10	10	7.37	2.08	1.34	11.49	0.74	-3.25	-1.05	1.75	3.51
261		3	-10	15	7.37	3.36	4.16	11.49	0.74	-2.38	-1.36	1.58	3.68
129		3	0	-15	7.36	3.22	-7.91	11.49	-0.99	-3.30	-1.37	1.66	3.66
124		3	0	-10	7.37	1.82	-4.41	11.49	-0.82	-4.64	-1.08	1.92	3.40
120		3	0	-5	7.38	1.34	-2.68	11.49	-0.45	-5.19	-0.89	2.01	3.31
81		3	0	0	7.36	1.25	-1.77	11.49	0.02	-5.26	-0.60	2.02	3.30
87		3	0	5	7.36	1.09	-1.80	11.49	0.48	-5.17	-0.61	2.03	3.29
107		3	0	5	7.36	1.40	-0.75	11.49	0.49	-4.78	-0.50	1.97	3.35
111		3	0	10	7.35	2.01	1.08	11.49	0.66	-3.76	-0.88	1.85	3.47
115		3	0	15	7.36	3.50	4.50	11.49	0.46	-1.94	-1.72	1.59	3.73
135		3	0	15	7.36	3.63	4.69	11.49	0.45	-1.86	-1.65	1.53	3.79

* Indicates model was close to heave stop

TABLE A1.311.2 - STABILITY DATA IN WIND AXES WITH AIR TARES

30 deg Deadrise, L/R = 0.117, Cv = 1.5

RUN	Trim deg	Roll deg	Yaw deg	Speed fps	X lb	Y lb	Z lb	K lb-ft	M lb-ft	N lb-ft	Heave in	TD in
188	3	10	-15	7.37	2.51	-5.42	11.49	-0.65	-1.82	-0.09	2.02	3.24
184	3	10	-10	7.37	1.98	-4.45	11.49	-0.87	-3.67	-0.79	1.93	3.33
180	3	10	-5	7.37	1.49	-2.62	11.49	-0.64	-4.40	-0.79	2.06	3.20
138	3	10	0	7.37	1.28	-1.72	11.49	-0.25	-4.76	-0.69	2.11	3.15
144	3	10	5	7.37	1.34	-0.96	11.49	0.14	-4.70	-0.76	2.05	3.21
146	3	10	5	7.37	1.35	-0.91	11.49	0.15	-4.69	-0.76	2.06	3.20
150	3	10	10	7.37	1.83	0.64	11.49	0.36	-3.92	-0.99	1.92	3.34
170	3	10	15	7.37	3.22	3.70	11.49	0.21	-2.28	-1.59	1.58	3.68
173	3	10	15	7.37	3.23	3.74	11.49	0.22	-2.29	-1.56	1.59	3.67
174	3	10	15	7.36	3.25	3.79	11.49	0.22	-2.28	-1.55	1.59	3.67
240	3	20	-15	7.35	2.43	-4.70	11.49	-0.50	-1.24	0.25	1.92	3.15
235	3	20	-10	7.34	1.74	-3.83	11.49	-0.95	-3.65	-0.44	1.98	3.09
231	3	20	-5	7.36	1.43	-2.67	11.49	-0.76	-4.49	-0.67	2.02	3.05
197	3	20	0	7.38	1.23	-1.76	11.49	-0.40	-4.88	-0.73	2.09	2.98
204	3	20	5	7.29	1.30	-0.90	11.49	-0.05	-4.68	-0.87	2.03	3.04
210	3	20	10	7.32	1.78	0.50	11.49	0.11	-3.98	-1.28	1.90	3.17
214	3	20	15	7.35	3.00	3.17	11.49	-0.25	-1.98	-1.84	1.58	3.49
437	6	-10	-15	7.36	2.64	-5.16	11.49	-1.41	-7.27	2.70	2.40	4.02
433	6	-10	-10	7.37	2.01	-3.80	11.49	-1.13	-8.47	1.35	2.43	3.99
429	6	-10	-5	7.37	1.67	-2.59	11.49	-0.45	-8.78	0.39	2.47	3.95
404	6	-10	0	7.36	1.61	-1.43	11.49	0.28	-8.47	-0.44	2.62	3.80
408	6	-10	5	7.38	1.85	-0.27	11.49	0.92	-8.13	-1.40	2.53	3.89
412	6	-10	10	7.37	2.52	1.79	11.49	1.28	-7.27	-3.01	2.40	4.02
425	6	-10	15	7.38	3.90	5.04	11.49	1.36	-6.07	-5.62	2.03	4.39
325	6	0	-15	7.37	2.96	-6.31	11.49	-1.65	-7.40	2.68	2.30	4.18
318	6	0	-10	7.37	2.04	-4.01	11.49	-1.33	-8.31	1.12	2.45	4.03
312	6	0	-5	7.38	1.68	-2.63	11.49	-0.74	-8.95	0.20	2.49	3.99
290	6	0	0	7.39	1.44	-1.51	11.49	0.04	-8.87	-0.51	2.59	3.89
294	6	0	5	7.37	1.76	-0.35	11.49	0.75	-8.60	-1.39	2.50	3.98
299	6	0	10	7.37	2.41	1.44	11.49	1.23	-7.82	-2.74	2.35	4.13
303	6	0	15	7.37	3.60	4.32	11.49	1.31	-6.52	-4.83	2.14	4.34
309	6	0	15	7.38	3.65	4.43	11.49	1.31	-6.55	-4.89	2.05	4.43
365	6	10	-15	7.36	3.08	-6.66	11.49	-1.75	-6.88	3.00	2.36	4.06
360	6	10	-10	7.37	2.08	-4.20	11.49	-1.50	-8.08	1.13	2.46	3.96
347	6	10	-5	7.37	1.73	-2.68	11.49	-0.97	-8.74	0.06	2.47	3.95
330	6	10	0	7.37	1.59	-1.62	11.49	-0.23	-8.98	-0.72	2.52	3.90
335	6	10	5	7.38	1.73	-0.39	11.49	0.50	-8.75	-1.57	2.47	3.95
339	6	10	10	7.38	2.30	1.19	11.49	1.07	-8.12	-2.77	2.36	4.06
343	6	10	15	7.38	3.45	3.76	11.49	1.22	-6.91	-4.61	2.12	4.30
398	6	20	-15	7.36	2.90	-6.11	11.49	-1.72	-6.40	3.12	2.44	3.79
394	6	20	-10	7.36	2.15	-4.43	11.49	-1.58	-7.91	1.53	2.55	3.68
390	6	20	-5	7.36	1.70	-2.72	11.49	-1.08	-8.42	0.23	2.62	3.61
373	6	20	0	7.36	1.61	-1.48	11.49	-0.44	-8.62	-0.70	2.60	3.63
377	6	20	5	7.36	1.76	-0.23	11.49	0.19	-8.36	-1.82	2.58	3.65
382	6	20	10	7.38	2.30	1.43	11.49	0.68	-7.50	-3.32	2.47	3.76
386	6	20	15	7.36	3.17	3.10	11.49	1.00	-6.69	-4.63	2.36	3.87

* Indicates model was close to heave stop

TABLE A1.313.1 - STABILITY DATA IN WIND AXES WITH AIR TARES

30 deg Deadrise, L/R = 0.117, Cv = 3

RUN	Trim deg	Roll deg	Yaw deg	Speed fps	X lb	Y lb	Z lb	K lb-ft	M lb-ft	N lb-ft	Heave in	TD in
562 *	0	-10	-10	14.75	9.79	-26.48	11.49	0.39	-0.92	-18.67	0.63	3.46
558	0	-10	-5	14.75	4.50	-13.16	11.49	0.44	3.18	-7.39	1.51	2.58
529	0	-10	0	14.74	3.20	-8.63	11.49	0.03	1.66	-1.85	1.78	2.31
533	0	-10	5	14.75	4.36	-4.53	11.49	-0.37	3.21	0.29	1.59	2.50
537	0	-10	10	14.74	8.04	5.55	11.49	-1.09	4.33	2.50	1.12	2.97
552	0	-10	15	14.74	6.54	3.49	11.49	-0.60	2.58	2.98	2.21	1.88
462 *	0	0	-10	14.72	9.44	-26.61	11.49	0.28	1.37	-18.22	0.87	3.28
458	0	0	-5	14.73	4.61	-12.92	11.49	0.08	1.85	-7.15	1.60	2.55
444	0	0	0	14.74	3.38	-8.58	11.49	-0.16	2.58	-2.90	1.74	2.41
449	0	0	5	14.76	4.24	-4.60	11.49	-0.53	4.70	0.15	1.58	2.57
453 *	0	0	10	14.76	10.39	9.25	11.49	-1.50	5.84	2.72	0.55	3.60
497	0	10	-15	14.73	3.85	-13.69	11.49	1.09	7.64	-4.52	2.86	1.23
493	0	10	-10	14.75	7.44	-22.71	11.49	0.62	2.77	-14.85	1.40	2.69
489	0	10	-5	14.75	4.55	-13.13	11.49	0.03	1.81	-6.61	1.67	2.42
468	0	10	0	14.73	3.72	-8.44	11.49	-0.34	1.44	-2.63	1.76	2.33
480	0	10	5	14.75	4.22	-4.38	11.49	-0.71	4.60	0.31	1.55	2.54
484	0	10	10	14.74	8.13	5.67	11.49	-1.64	6.66	2.35	1.02	3.07
524	0	20	-15	14.75	6.83	-18.09	11.49	3.31	12.97	-6.26	2.24	1.66
520	0	20	-10	14.74	6.94	-17.51	11.49	1.87	12.30	-9.88	1.58	2.32
516	0	20	-5	14.74	4.49	-13.21	11.49	-0.03	2.25	-6.53	1.77	2.13
502	0	20	0	14.77	3.58	-8.95	11.49	-0.51	1.43	-2.82	1.83	2.07
506	0	20	5	14.76	4.06	-5.01	11.49	-0.89	2.80	-0.26	1.70	2.20
510	0	20	10	14.75	7.26	3.74	11.49	-1.77	6.11	4.25	1.28	2.62
277	3	-10	-15	14.73	8.04	-25.96	11.49	0.19	0.61	-2.46	2.00	3.26
273	3	-10	-10	14.74	4.04	-15.70	11.49	-0.48	-3.77	-1.16	2.30	2.96
269	3	-10	-5	14.75	2.73	-10.32	11.49	-0.26	-4.44	-0.96	2.37	2.89
247	3	-10	0	14.74	2.39	-7.09	11.49	0.17	-4.07	-1.03	2.38	2.88
254	3	-10	5	14.74	3.19	-3.76	11.49	0.36	-2.68	-2.06	2.36	2.90
258	3	-10	10	14.73	5.49	3.77	11.49	-0.25	0.82	-6.17	2.15	3.11
262	3	-10	15	14.77	3.73	-1.22	11.49	2.48	-8.71	-5.92	3.34	1.92
130	3	0	-15	14.68	9.73	-30.66	11.49	0.33	3.88	-2.48	1.95	3.37
125	3	0	-10	14.71	4.49	-16.89	11.49	-0.61	-1.94	-2.13	2.32	3.00
121	3	0	-5	14.72	2.96	-10.82	11.49	-0.64	-4.42	-2.10	2.43	2.89
82	3	0	0	14.67	2.47	-7.40	11.49	-0.12	-4.80	-1.64	2.47	2.85
88	3	0	5	14.71	1.79	-7.60	11.49	0.29	-4.81	-1.64	2.48	2.84
101	3	0	5	14.71	3.16	-3.26	11.49	0.26	-3.95	-3.36	2.42	2.90
105	3	0	5	14.67	3.09	-3.81	11.49	0.27	-3.52	-2.16	2.41	2.91
112	3	0	10	14.68	5.62	3.63	11.49	-0.18	0.07	-4.77	2.15	3.17
116	3	0	15	14.68	12.10	19.39	11.49	-2.40	8.24	-8.46	1.57	3.75
132	3	0	15	14.67	12.95	21.07	11.49	-2.61	9.20	-7.78	1.41	3.91

* Indicates model was close to heave stop

TABLE A1.313.2 - STABILITY DATA IN WIND AXES WITH AIR TARES

30 deg Deadrise, L/R = 0.117, Cv = 3

RUN	Trim deg	Roll deg	Yaw deg	Speed fps	X lb	Y lb	Z lb	K lb-ft	M lb-ft	N lb-ft	Heave in	TD in
191	3	10	-15	14.73	3.13	-13.55	11.49	-2.07	-5.70	2.23	3.25	2.01
185	3	10	-10	14.73	4.46	-16.79	11.49	-0.52	-0.15	-0.47	2.37	2.89
181	3	10	-5	14.72	2.92	-10.95	11.49	-0.76	-2.86	-1.84	2.46	2.80
141	3	10	0	14.68	2.51	-7.63	11.49	-0.47	-4.25	-2.31	2.55	2.71
147	3	10	5	14.71	2.71	-4.43	11.49	-0.00	-4.08	-2.97	2.53	2.73
151	3	10	10	14.70	4.52	1.08	11.49	-0.06	-2.00	-4.38	2.37	2.89
175	3	10	15	14.69	10.13	14.08	11.49	-1.94	5.32	-7.45	1.79	3.47
241	3	20	-15	14.72	3.06	-12.84	11.49	-1.65	-3.83	3.26	3.11	1.96
236	3	20	-10	14.77	3.26	-12.79	11.49	-0.80	-1.11	0.86	2.64	2.43
232	3	20	-5	14.74	2.90	-10.70	11.49	-0.85	-2.69	-0.84	2.44	2.63
200	3	20	0	14.72	2.48	-7.34	11.49	-0.71	-3.21	-2.42	2.50	2.57
206	3	20	5	14.66	2.58	-4.63	11.49	-0.35	-3.63	-3.69	2.60	2.47
211	3	20	10	14.74	3.72	-0.93	11.49	-0.22	-3.68	-6.10	2.63	2.44
215	3	20	15	14.98	6.35	5.24	11.49	-0.53	-3.12	-10.13	2.57	2.50
216	3	20	15	14.75	6.32	5.34	11.49	-0.55	-2.88	-9.77	2.55	2.52
438	6	-10	-15	14.75	4.21	-16.21	11.49	-2.04	-10.83	7.76	3.55	2.87
434	6	-10	-10	14.73	2.80	-12.35	11.49	-1.49	-10.87	3.92	3.58	2.84
430	6	-10	-5	14.73	2.13	-9.54	11.49	-0.66	-10.19	1.10	3.48	2.94
405	6	-10	0	14.71	2.15	-6.86	11.49	0.15	-8.81	-1.16	3.46	2.96
409	6	-10	5	14.75	3.08	-3.23	11.49	0.57	-7.73	-4.78	3.34	3.08
413	6	-10	10	14.75	4.57	1.78	11.49	0.42	-6.49	-9.96	3.28	3.14
426	6	-10	15	14.74	8.05	10.40	11.49	-0.65	-3.57	-18.23	2.92	3.50
326	6	0	-15	14.75	5.37	-18.95	11.49	-1.47	-7.70	7.45	3.16	3.32
319	6	0	-10	14.77	3.17	-13.22	11.49	-1.58	-9.47	3.31	3.38	3.10
315	6	0	-5	14.76	2.41	-9.85	11.49	-0.96	-10.31	0.69	3.46	3.02
292	6	0	0	14.78	2.16	-6.97	11.49	-0.13	-10.12	-1.68	3.55	2.93
296	6	0	5	14.76	2.71	-3.97	11.49	0.58	-9.26	-4.14	3.44	3.04
300	6	0	10	14.76	4.26	0.57	11.49	0.80	-7.88	-8.36	3.29	3.19
304	6	0	15	14.72	7.53	8.58	11.49	-0.11	-4.99	-15.58	2.99	3.49
366	6	10	-15	14.74	6.12	-20.79	11.49	-1.11	-6.05	9.70	3.13	3.29
361	6	10	-10	14.86	3.44	-13.48	11.49	-1.47	-7.83	3.43	3.32	3.10
363	6	10	-10	14.72	3.41	-13.43	11.49	-1.48	-7.80	3.43	3.34	3.08
357	6	10	-5	14.78	2.46	-9.76	11.49	-1.20	-9.04	0.02	3.42	3.00
331	6	10	0	14.75	2.11	-7.19	11.49	-0.43	-10.11	-1.98	3.56	2.86
336	6	10	5	14.77	2.49	-4.33	11.49	0.36	-10.63	-4.72	3.59	2.83
340	6	10	10	14.76	3.69	-0.84	11.49	0.98	-10.57	-8.40	3.57	2.85
344	6	10	15	14.76	5.89	4.19	11.49	1.07	-9.48	-13.13	3.41	3.01
400	6	20	-15	14.73	4.85	-17.53	11.49	-1.89	-8.47	9.46	3.58	2.65
395	6	20	-10	14.69	3.34	-13.65	11.49	-1.45	-7.67	4.78	3.47	2.76
391	6	20	-5	14.72	2.52	-9.43	11.49	-1.30	-8.08	0.27	3.43	2.80
374	6	20	0	14.77	2.20	-7.03	11.49	-0.70	-9.02	-2.13	3.60	2.63
378	6	20	5	14.74	2.28	-4.87	11.49	0.04	-10.28	-4.54	3.79	2.44
383	6	20	10	14.77	3.05	-2.51	11.49	0.78	-11.04	-7.59	3.92	2.31
387	6	20	15	14.72	4.46	0.33	11.49	1.35	-11.38	-11.37	3.96	2.27

* Indicates model was close to heave stop

TABLE A1.314.1 - STABILITY DATA IN WIND AXES WITH AIR TARES

30 deg Deadrise, L/R = 0.117, Cv = 4

RUN	Trim deg	Roll deg	Yaw deg	Speed fps	X lb	Y lb	Z lb	K lb-ft	M lb-ft	N lb-ft	Heave in	TD in
559	0	-10	-5	19.58	7.61	-22.91	11.49	0.68	8.18	-13.82	1.50	2.59
530	0	-10	0	19.66	5.52	-15.48	11.49	-0.24	5.30	-3.62	1.72	2.37
534	0	-10	5	19.64	8.91	-6.78	11.49	-1.04	7.55	-1.37	1.24	2.85
554 *	0	-10	10	19.61	15.32	12.28	11.49	-1.39	4.77	10.38	0.67	3.42
553	0	-10	15	19.61	3.65	-8.49	11.49	0.20	-1.16	0.70	3.22	0.87
459	0	0	-5	19.61	8.32	-21.99	11.49	0.47	5.59	-13.73	1.50	2.65
445	0	0	0	19.65	5.47	-15.39	11.49	-0.31	5.81	-5.21	1.77	2.38
450	0	0	5	19.66	7.64	-7.88	11.49	-1.09	9.50	-0.30	1.45	2.70
498	0	10	-15	19.69	3.64	-20.69	11.49	-0.39	0.70	-2.70	3.32	0.77
494	0	10	-10	19.64	12.32	-38.72	11.49	0.86	3.40	-27.34	1.44	2.65
490	0	10	-5	19.65	8.12	-22.67	11.49	0.42	4.86	-14.06	1.60	2.49
469	0	10	0	19.63	6.51	-14.73	11.49	-0.43	3.34	-4.69	1.74	2.35
481	0	10	5	19.62	7.63	-7.29	11.49	-1.08	9.97	0.94	1.43	2.66
525	0	20	-15	19.62	6.09	-22.64	11.49	1.76	8.53	-2.20	2.98	0.92
521	0	20	-10	19.66	10.37	-28.33	11.49	3.28	21.98	-14.50	1.80	2.10
517	0	20	-5	19.61	7.77	-23.03	11.49	0.35	5.65	-13.16	1.75	2.15
503	0	20	0	19.67	6.44	-15.39	11.49	-0.55	3.13	-5.55	1.80	2.10
507	0	20	5	19.67	7.43	-7.87	11.49	-1.10	5.80	0.45	1.58	2.32
278	3	-10	-15	19.60	13.12	-45.13	11.49	0.78	4.05	-4.62	2.09	3.17
274	3	-10	-10	19.60	5.89	-26.25	11.49	-0.65	-4.64	-0.22	2.51	2.75
270	3	-10	-5	19.63	3.78	-17.38	11.49	-0.47	-5.07	-0.96	2.67	2.59
248	3	-10	0	19.63	3.58	-12.63	11.49	0.02	-2.72	-1.86	2.58	2.68
255	3	-10	5	19.61	4.68	-7.64	11.49	0.07	-1.59	-3.99	2.62	2.64
259	3	-10	10	19.66	7.52	2.05	11.49	-0.81	2.74	-10.15	2.51	2.75
265	3	-10	15	19.64	3.91	-6.79	11.49	2.86	-12.11	-8.92	3.81	1.45
131	3	0	-15	19.58	16.28	-53.76	11.49	1.52	11.00	-3.89	1.99	3.33
126	3	0	-10	19.62	6.85	-28.53	11.49	-0.54	-0.09	-3.17	2.46	2.86
122	3	0	-5	19.63	4.00	-18.50	11.49	-0.80	-4.43	-2.20	2.69	2.63
83	3	0	0	19.61	3.60	-13.25	11.49	-0.26	-4.81	-2.59	2.74	2.58
106	3	0	5	19.60	4.49	-7.58	11.49	0.10	-3.14	-4.19	2.66	2.66
113	3	0	10	19.59	7.91	3.02	11.49	-0.65	1.33	-9.24	2.46	2.86
117	3	0	15	19.59	20.52	34.19	11.49	-5.29	18.70	-15.23	1.57	3.75
133	3	0	15	19.61	24.02	41.74	11.49	-6.35	23.25	-12.23	1.07	4.25

* Indicates model was close to heave stop

TABLE A1.314.2 - STABILITY DATA IN WIND AXES WITH AIR TARES

30 deg Deadrise, L/R = 0.117, Cv = 4

RUN	Trim deg	Roll deg	Yaw deg	Speed fps	X lb	Y lb	Z lb	K lb-ft	M lb-ft	N lb-ft	Heave in	TD in
192	3	10	-15	19.66	4.16	-22.50	11.49	-3.40	-11.08	5.38	3.56	1.70
193	3	10	-15	19.65	4.19	-22.76	11.49	-3.16	-10.33	5.72	3.56	1.70
186	3	10	-10	19.63	5.31	-25.00	11.49	-0.62	-0.18	1.26	2.83	2.43
182	3	10	-5	19.64	3.62	-17.98	11.49	-0.90	-2.44	-1.98	2.81	2.45
143	3	10	0	19.61	3.41	-13.75	11.49	-0.60	-4.57	-3.19	2.82	2.44
148	3	10	5	19.61	4.02	-8.62	11.49	-0.03	-5.49	-5.46	2.85	2.41
153	3	10	10	19.62	6.47	-0.14	11.49	-0.13	-3.56	-9.38	2.70	2.56
178	3	10	15	19.63	15.67	21.11	11.49	-3.20	9.25	-13.18	1.97	3.29
243	3	20	-15	19.62	2.83	-18.29	11.49	-3.71	-10.71	3.46	3.65	1.42
238	3	20	-10	19.63	3.30	-18.57	11.49	-1.71	-4.59	1.95	3.16	1.91
233	3	20	-5	19.55	3.86	-17.33	11.49	-1.01	-1.33	-1.23	2.71	2.36
201	3	20	0	19.75	3.13	-13.93	11.49	-0.96	-3.12	-2.86	2.85	2.22
202	3	20	0	19.72	3.11	-13.84	11.49	-0.94	-3.17	-2.79	2.86	2.21
207	3	20	5	19.68	3.43	-9.99	11.49	-0.49	-5.26	-5.29	2.99	2.08
212	3	20	10	19.62	5.05	-4.69	11.49	-0.30	-6.14	-9.75	2.99	2.08
229	3	20	15	19.59	8.60	4.04	11.49	-0.66	-6.14	-16.95	2.87	2.20
439	6	-10	-15	19.67	4.67	-23.64	11.49	-2.66	-14.79	11.03	4.19	2.23
435	6	-10	-10	19.66	3.05	-19.22	11.49	-1.94	-14.32	5.30	4.22	2.20
431	6	-10	-5	19.65	2.03	-15.49	11.49	-1.05	-13.67	0.79	4.21	2.21
406	6	-10	0	19.64	2.49	-12.05	11.49	-0.14	-12.49	-3.10	4.20	2.22
410	6	-10	5	19.70	3.25	-8.71	11.49	0.54	-10.83	-6.86	4.15	2.27
414	6	-10	10	19.65	4.57	-4.65	11.49	0.95	-11.41	-12.65	4.27	2.15
427	6	-10	15	19.65	6.80	0.29	11.49	0.99	-10.62	-19.34	4.13	2.29
327	6	0	-15	19.61	5.87	-26.70	11.49	-2.70	-13.72	12.64	3.98	2.50
322	6	0	-10	19.63	3.57	-20.71	11.49	-2.20	-14.09	6.51	4.15	2.33
316	6	0	-5	19.67	2.74	-16.64	11.49	-1.33	-14.34	1.67	4.11	2.37
293	6	0	0	19.66	2.51	-12.62	11.49	-0.38	-13.82	-3.00	4.19	2.29
297	6	0	5	19.65	3.20	-8.62	11.49	0.44	-13.14	-7.70	4.16	2.32
301	6	0	10	19.66	4.57	-4.19	11.49	0.93	-12.69	-13.24	4.15	2.33
306	6	0	15	19.67	7.02	1.24	11.49	1.09	-12.30	-19.87	4.11	2.37
368	6	10	-15	19.64	6.81	-28.36	11.49	-2.13	-10.61	13.81	3.83	2.59
362	6	10	-10	19.62	3.46	-20.34	11.49	-2.20	-11.84	5.58	4.16	2.26
358	6	10	-5	19.65	2.59	-16.87	11.49	-1.49	-12.73	1.81	4.30	2.12
333	6	10	0	19.64	2.22	-13.78	11.49	-0.63	-13.63	-1.95	4.22	2.20
337	6	10	5	19.67	2.88	-9.97	11.49	0.19	-13.84	-6.55	4.20	2.22
341	6	10	10	19.69	4.37	-5.47	11.49	0.82	-13.91	-12.41	4.16	2.26
345	6	10	15	19.69	6.84	0.27	11.49	1.03	-13.74	-19.94	4.09	2.33
370	6	10	15	19.63	6.88	0.40	11.49	1.03	-13.72	-20.11	4.15	2.27
401	6	20	-15	19.60	4.76	-23.46	11.49	-2.94	-12.11	11.32	4.38	1.85
396	6	20	-10	19.59	3.73	-20.33	11.49	-2.16	-11.03	6.35	4.17	2.06
392	6	20	-5	19.63	2.58	-16.28	11.49	-1.66	-10.83	1.07	4.19	2.04
375	6	20	0	19.68	2.32	-14.19	11.49	-0.84	-12.70	-1.50	4.38	1.85
379	6	20	5	19.64	2.39	-11.72	11.49	0.05	-13.76	-4.61	4.49	1.74
380	6	20	5	19.66	2.37	-11.75	11.49	0.04	-13.79	-4.67	4.49	1.74
384	6	20	10	19.64	3.17	-9.14	11.49	0.83	-13.96	-8.30	4.52	1.71
388	6	20	15	19.63	4.85	-5.59	11.49	1.37	-14.18	-13.44	4.47	1.76

* Indicates model was close to heave stop

TABLE A1.320.1 - STABILITY DATA IN WIND AXES WITH AIR TARES

30 deg Deadrise, L/R = 0.234, Cv = 0

RUN	Trim deg	Roll deg	Yaw deg	Speed fps	X lb	Y lb	Z lb	K lb-ft	M lb-ft	N lb-ft	Heave in	TD in
1126	0	-10	-15	0.00	0.01	-0.17	11.49	-0.62	-3.30	0.03	1.92	2.17
1122	0	-10	-10	0.00	0.03	-0.29	11.49	-0.29	-3.26	0.03	1.95	2.14
1117	0	-10	-5	0.00	-0.00	-0.31	11.49	0.00	-3.29	0.04	1.95	2.14
1101	0	-10	0	0.00	0.02	-0.28	11.49	0.28	-3.23	0.05	1.97	2.12
1105	0	-10	5	0.00	-0.01	-0.25	11.49	0.56	-3.18	0.05	1.96	2.13
1110	0	-10	10	0.00	-0.03	-0.27	11.49	0.83	-3.06	0.03	1.95	2.14
1113	0	-10	15	0.00	0.02	-0.11	11.49	1.02	-2.87	0.01	1.95	2.14
1024	0	0	-15	0.00	-0.02	-0.16	11.49	-0.78	-3.06	0.03	1.86	2.29
1020	0	0	-10	0.00	0.01	-0.27	11.49	-0.46	-3.10	0.03	1.88	2.27
1016	0	0	-5	0.00	0.01	-0.25	11.49	-0.19	-3.09	0.05	1.88	2.27
1003	0	0	0	0.00	0.01	-0.04	11.49	0.04	-2.93	0.04	1.93	2.22
1085	0	0	0	0.00	-0.03	-0.32	11.49	0.07	-3.18	0.00	1.91	2.24
1007	0	0	5	0.00	-0.01	-0.20	11.49	0.34	-2.93	0.04	1.89	2.26
1011	0	0	10	0.00	-0.04	-0.31	11.49	0.59	-2.91	0.03	1.90	2.25
1014	0	0	15	0.00	-0.01	-0.15	11.49	0.78	-2.84	0.04	1.87	2.28
1058	0	10	-15	0.00	-0.00	-0.10	11.49	-1.07	-3.20	0.01	2.02	2.07
1054	0	10	-10	0.00	-0.01	-0.14	11.49	-0.80	-3.25	0.03	1.99	2.10
1050	0	10	-5	0.00	-0.01	-0.11	11.49	-0.50	-3.29	0.04	2.00	2.09
1035	0	10	0	0.00	0.01	-0.10	11.49	-0.17	-3.16	0.02	2.02	2.07
1039	0	10	5	0.00	-0.01	-0.23	11.49	0.13	-3.26	0.02	2.03	2.06
1043	0	10	10	0.00	-0.02	-0.24	11.49	0.43	-3.22	0.02	2.04	2.05
1048	0	10	15	0.00	0.00	-0.15	11.49	0.65	-3.18	0.02	2.00	2.09
1096	0	20	-15	0.00	0.05	-0.35	11.49	-1.20	-3.43	0.04	2.06	1.84
1092	0	20	-10	0.00	0.02	-0.30	11.49	-0.89	-3.49	0.02	2.05	1.85
1087	0	20	-5	0.00	0.03	-0.24	11.49	-0.58	-3.48	0.04	2.07	1.83
1063	0	20	0	0.00	0.02	-0.13	11.49	-0.31	-3.44	0.03	2.12	1.78
1067	0	20	5	0.00	0.01	-0.10	11.49	-0.03	-3.48	0.03	2.10	1.80
1072	0	20	10	0.00	-0.00	-0.24	11.49	0.33	-3.47	0.01	2.10	1.80
1076	0	20	15	0.00	-0.03	-0.26	11.49	0.63	-3.41	0.02	2.11	1.79
832	3	-10	-15	0.00	-0.02	-0.11	11.49	-1.86	-8.16	0.04	2.13	3.13
828	3	-10	-10	0.00	-0.03	-0.20	11.49	-1.16	-8.35	0.06	2.11	3.15
824	3	-10	-5	0.00	-0.03	-0.20	11.49	-0.37	-8.40	0.03	2.12	3.14
800	3	-10	0	0.00	-0.04	-0.22	11.49	0.36	-8.36	0.05	2.20	3.06
816	3	-10	10	0.00	-0.06	-0.21	11.49	1.80	-8.14	0.01	2.12	3.14
820	3	-10	15	0.00	-0.06	-0.24	11.49	2.52	-8.01	0.01	2.10	3.16
692	3	0	-15	0.00	-0.04	-0.07	11.49	-2.09	-8.12	0.05	2.11	3.21
688	3	0	-10	0.00	-0.02	-0.21	11.49	-1.39	-8.31	0.06	2.10	3.22
699	3	0	-10	0.00	-0.04	-0.06	11.49	-1.37	-8.29	0.06	2.09	3.23
684	3	0	-5	0.00	-0.06	-0.06	11.49	-0.65	-8.33	0.02	2.12	3.20
704	3	0	-5	0.00	-0.04	-0.16	11.49	-0.67	-8.46	0.07	2.07	3.25
657	3	0	0	0.00	-0.04	-0.06	11.49	0.08	-8.30	0.04	2.09	3.23
708	3	0	0	0.00	-0.02	-0.09	11.49	0.07	-8.32	0.04	2.10	3.22
661	3	0	5	0.00	-0.04	-0.07	11.49	0.80	-8.32	0.06	2.08	3.24
712	3	0	5	0.00	-0.04	-0.12	11.49	0.79	-8.28	0.04	2.10	3.22
675	3	0	10	0.00	-0.03	-0.09	11.49	1.52	-8.22	0.01	2.12	3.20
718	3	0	10	0.00	-0.03	-0.02	11.49	1.54	-8.26	0.05	2.07	3.25
679	3	0	15	0.00	-0.02	-0.09	11.49	2.23	-8.04	0.01	2.10	3.22
722	3	0	15	0.00	-0.06	-0.15	11.49	2.21	-8.03	0.04	2.08	3.24

* Indicates model was close to heave stop

TABLE A1.320.2 - STABILITY DATA IN WIND AXES WITH AIR TARES

30 deg Deadrise, L/R = 0.234, Cv = 0

RUN	Trim deg	Roll deg	Yaw deg	Speed fps	X lb	Y lb	Z lb	K lb-ft	M lb-ft	N lb-ft	Heave in	TD in
764	3	10	-15	0.00	-0.03	-0.16	11.49	-2.34	-8.16	0.05	2.20	3.06
760	3	10	-10	0.00	-0.04	-0.08	11.49	-1.60	-8.23	0.04	2.21	3.05
756	3	10	-5	0.00	-0.03	-0.23	11.49	-0.85	-8.42	0.04	2.19	3.07
726	3	10	0	0.00	-0.03	-0.11	11.49	-0.15	-8.42	0.03	2.13	3.13
752	3	10	5	0.00	-0.03	-0.12	11.49	0.57	-8.32	0.04	2.18	3.08
730	3	10	10	0.00	-0.05	-0.11	11.49	1.31	-8.29	0.03	2.11	3.15
743	3	10	10	0.00	0.01	-0.12	11.49	1.28	-8.15	0.02	2.18	3.08
748	3	10	15	0.00	-0.06	-0.25	11.49	2.05	-8.06	-0.01	2.17	3.09
795	3	20	-15	0.00	-0.01	-0.18	11.49	-2.49	-8.20	0.03	2.27	2.80
791	3	20	-10	0.00	-0.03	-0.12	11.49	-1.77	-8.34	0.04	2.27	2.80
787	3	20	-5	0.00	-0.05	-0.09	11.49	-1.03	-8.39	0.05	2.27	2.80
771	3	20	0	0.00	-0.02	-0.33	11.49	-0.27	-8.50	0.03	2.26	2.81
775	3	20	5	0.00	-0.03	-0.24	11.49	0.49	-8.49	0.02	2.26	2.81
779	3	20	10	0.00	-0.05	-0.23	11.49	1.23	-8.40	0.03	2.26	2.81
783	3	20	15	0.00	-0.06	-0.24	11.49	1.91	-8.26	0.02	2.25	2.82
994	6	-10	-15	0.00	-0.05	-0.11	11.49	-2.64	-11.04	0.04	2.47	3.95
989	6	-10	-10	0.00	-0.04	-0.12	11.49	-1.67	-11.27	0.07	2.47	3.95
985	6	-10	-5	0.00	-0.05	-0.13	11.49	-0.68	-11.36	0.04	2.47	3.95
962	6	-10	0	0.00	-0.05	-0.07	11.49	0.31	-11.38	0.06	2.46	3.96
965	6	-10	5	0.00	-0.04	-0.07	11.49	1.30	-11.30	0.09	2.46	3.96
977	6	-10	10	0.00	-0.02	-0.07	11.49	2.28	-11.12	0.05	2.47	3.95
981	6	-10	15	0.00	-0.04	-0.07	11.49	3.21	-10.78	0.05	2.47	3.95
864	6	0	-15	0.00	-0.03	-0.10	11.49	-2.88	-11.14	0.05	2.42	4.06
860	6	0	-10	0.00	-0.06	-0.11	11.49	-1.91	-11.38	0.07	2.41	4.07
856	6	0	-5	0.00	-0.04	-0.10	11.49	-0.92	-11.50	0.04	2.40	4.08
839	6	0	0	0.00	-0.03	-0.04	11.49	0.10	-11.46	0.06	2.45	4.03
844	6	0	5	0.00	-0.03	-0.05	11.49	1.10	-11.45	0.07	2.40	4.08
848	6	0	10	0.00	-0.04	-0.10	11.49	2.09	-11.30	0.06	2.41	4.07
852	6	0	15	0.00	-0.02	-0.09	11.49	3.06	-11.02	0.03	2.40	4.08
923	6	10	-15	0.00	-0.04	-0.11	11.49	-3.07	-11.04	0.04	2.50	3.92
919	6	10	-10	0.00	-0.03	-0.11	11.49	-2.10	-11.28	0.04	2.49	3.93
915	6	10	-5	0.00	-0.03	-0.08	11.49	-1.11	-11.40	0.05	2.49	3.93
869	6	10	0	0.00	-0.03	-0.12	11.49	-0.11	-11.44	0.08	2.44	3.98
881	6	10	0	0.00	-0.01	-0.04	11.49	-0.11	-11.45	0.07	2.53	3.89
912	6	10	0	0.00	-0.02	-0.12	11.49	-0.11	-11.50	0.06	2.50	3.92
888	6	10	5	0.00	-0.03	-0.04	11.49	0.88	-11.38	0.08	2.50	3.92
892	6	10	10	0.00	-0.03	-0.07	11.49	1.86	-11.24	0.06	2.49	3.93
898	6	10	15	0.00	-0.03	-0.08	11.49	2.86	-11.12	0.05	2.48	3.94
913	6	10	15	0.00	-0.01	-0.03	11.49	2.82	-11.00	0.04	2.50	3.92
955	6	20	-15	0.00	-0.05	-0.14	11.49	-3.21	-10.95	0.04	2.54	3.69
951	6	20	-10	0.00	-0.04	-0.14	11.49	-2.26	-11.28	0.06	2.54	3.69
946	6	20	-5	0.00	-0.04	-0.10	11.49	-1.28	-11.44	0.06	2.53	3.70
928	6	20	0	0.00	-0.04	-0.08	11.49	-0.27	-11.52	0.07	2.53	3.70
932	6	20	5	0.00	-0.03	-0.05	11.49	0.73	-11.39	0.08	2.55	3.68
936	6	20	10	0.00	-0.02	-0.08	11.49	1.71	-11.29	0.06	2.52	3.71
943	6	20	15	0.00	-0.04	-0.10	11.49	2.70	-11.16	0.04	2.52	3.71

* Indicates model was close to heave stop

TABLE A1.321.1 - STABILITY DATA IN WIND AXES WITH AIR TARES

30 deg Deadrise, L/R = 0.234, Cv = 1.5

RUN	Trim deg	Roll deg	Yaw deg	Speed fps	X lb	Y lb	Z lb	K lb-ft	M lb-ft	N lb-ft	Heave in	TD in
1127	0	-10	-15	7.35	3.65	-11.12	11.49	0.54	0.50	-8.06	1.04	3.05
1129	*	0	-10	7.36	3.92	-11.68	11.49	0.56	0.55	-9.08	0.87	3.22
1123	0	-10	-10	7.36	1.99	-7.39	11.49	0.36	0.01	-4.90	1.46	2.63
1118	0	-10	-5	7.36	1.28	-5.41	11.49	0.22	-0.21	-2.77	1.65	2.44
1102	0	-10	0	7.36	1.12	-4.31	11.49	0.13	0.35	-1.26	1.72	2.37
1106	0	-10	5	7.36	1.23	-3.47	11.49	-0.00	1.17	-0.54	1.66	2.43
1111	0	-10	10	7.36	1.92	-1.78	11.49	-0.37	2.30	0.00	1.47	2.62
1114	0	-10	15	7.36	2.95	0.20	11.49	-0.84	2.78	1.79	1.28	2.81
1025	0	0	-15	7.35	3.79	-12.07	11.49	0.06	0.46	-8.66	1.07	3.08
1021	0	0	-10	7.35	2.06	-7.80	11.49	0.16	0.57	-5.02	1.45	2.70
1017	0	0	-5	7.35	1.38	-5.49	11.49	0.02	0.27	-3.04	1.60	2.55
1004	0	0	0	7.37	1.15	-4.26	11.49	-0.07	0.65	-1.62	1.66	2.49
1008	0	0	5	7.37	1.31	-3.38	11.49	-0.22	1.49	-0.75	1.57	2.58
1012	0	0	10	7.36	1.97	-1.72	11.49	-0.67	2.92	-0.22	1.39	2.76
1015	*	0	0	7.35	4.02	2.48	11.49	-1.63	5.48	0.65	0.87	3.28
1059	0	10	-15	7.36	3.70	-9.86	11.49	0.72	2.37	-7.24	1.20	2.89
1055	0	10	-10	7.35	2.05	-7.64	11.49	0.08	0.78	-4.98	1.55	2.54
1051	0	10	-5	7.36	1.45	-5.60	11.49	-0.12	0.50	-3.13	1.67	2.42
1036	0	10	0	7.37	1.21	-4.40	11.49	-0.24	0.68	-1.73	1.76	2.33
1040	0	10	5	7.36	1.31	-3.51	11.49	-0.49	1.31	-0.86	1.71	2.38
1044	0	10	10	7.35	1.89	-2.01	11.49	-0.98	2.78	-0.17	1.51	2.58
1045	0	10	10	7.37	1.96	-1.83	11.49	-1.03	2.85	-0.15	1.49	2.60
1049	0	10	15	7.36	3.74	1.65	11.49	-2.10	5.67	0.66	0.98	3.11
1097	0	20	-15	7.37	3.76	-9.63	11.49	0.53	1.98	-6.96	1.17	2.73
1093	0	20	-10	7.36	2.04	-6.79	11.49	-0.11	0.48	-4.18	1.56	2.34
1088	0	20	-5	7.37	1.42	-5.44	11.49	-0.26	0.28	-2.79	1.76	2.14
1064	0	20	0	7.36	1.23	-4.40	11.49	-0.39	0.46	-1.72	1.83	2.07
1068	0	20	5	7.38	1.32	-3.59	11.49	-0.62	1.16	-0.92	1.77	2.13
1071	0	20	10	7.36	1.84	-2.25	11.49	-1.20	2.58	-0.20	1.56	2.34
1073	0	20	10	7.36	1.86	-2.10	11.49	-1.22	2.64	-0.22	1.56	2.34
1077	0	20	15	7.35	3.36	0.84	11.49	-2.31	5.10	0.99	1.18	2.72
833	3	-10	-15	7.37	2.55	-8.75	11.49	-0.93	-4.62	-2.03	1.75	3.51
829	3	-10	-10	7.36	1.59	-6.16	11.49	-0.67	-5.50	-1.46	1.93	3.33
825	3	-10	-5	7.37	1.20	-4.50	11.49	-0.25	-5.56	-1.06	2.02	3.24
801	3	-10	0	7.36	1.17	-3.57	11.49	0.21	-5.13	-0.98	2.08	3.18
813	3	-10	5	7.38	1.37	-2.42	11.49	0.52	-4.18	-1.33	1.96	3.30
817	3	-10	10	7.39	2.14	-0.23	11.49	0.47	-2.62	-2.35	1.79	3.47
821	3	-10	15	7.38	3.90	3.54	11.49	0.18	-0.80	-3.78	1.49	3.77
698	3	0	-15	7.36	2.93	-9.65	11.49	-1.26	-4.17	-2.64	1.65	3.67
689	3	0	-10	7.36	1.52	-6.29	11.49	-0.90	-4.98	-1.55	2.07	3.25
700	3	0	-10	7.36	1.67	-6.37	11.49	-0.91	-5.09	-1.85	1.89	3.43
685	3	0	-5	7.35	1.20	-4.69	11.49	-0.48	-5.40	-1.44	2.05	3.27
705	3	0	-5	7.36	1.28	-4.86	11.49	-0.51	-5.47	-1.46	1.98	3.34
658	3	0	0	7.36	1.16	-3.71	11.49	0.00	-5.24	-1.18	2.00	3.32
711	3	0	0	7.36	1.19	-3.68	11.49	-0.01	-5.20	-1.21	2.01	3.31
662	3	0	5	7.35	1.32	-2.69	11.49	0.39	-4.62	-1.31	1.92	3.40
713	3	0	5	7.36	1.32	-2.63	11.49	0.39	-4.59	-1.30	1.94	3.38
676	3	0	10	7.36	2.01	-0.69	11.49	0.49	-3.37	-2.06	1.83	3.49
719	3	0	10	7.38	2.05	-0.56	11.49	0.49	-3.29	-2.00	1.76	3.56

* Indicates model was close to heave stop

TABLE A1.321.2 - STABILITY DATA IN WIND AXES WITH AIR TARES

30 deg Deadrise, L/R = 0.234, Cv = 1.5

RUN	Trim deg	Roll deg	Yaw deg	Speed fps	X lb	Y lb	Z lb	K lb-ft	M lb-ft	N lb-ft	Heave in	TD in
680	3	0	15	7.35	3.73	3.16	11.49	0.02	-0.94	-3.49	1.48	3.84
723	3	0	15	7.36	3.77	3.19	11.49	0.00	-0.89	-3.42	1.42	3.90
765	3	10	-15	7.35	2.62	-8.68	11.49	-1.11	-2.99	-1.74	1.92	3.34
761	3	10	-10	7.36	1.73	-6.55	11.49	-1.12	-4.63	-1.59	2.03	3.23
757	3	10	-5	7.35	1.28	-4.93	11.49	-0.76	-5.09	-1.44	2.11	3.15
727	3	10	0	7.36	1.19	-3.82	11.49	-0.31	-5.24	-1.30	2.05	3.21
753	3	10	5	7.36	1.34	-2.96	11.49	0.07	-4.73	-1.50	2.04	3.22
731	3	10	10	7.35	1.86	-1.14	11.49	0.22	-3.60	-2.08	1.80	3.46
749	3	10	15	7.37	3.33	2.13	11.49	-0.13	-1.39	-3.06	1.58	3.68
796	3	20	-15	7.35	2.35	-7.36	11.49	-0.96	-2.36	-0.98	1.91	3.16
792	3	20	-10	7.35	1.64	-6.07	11.49	-1.19	-4.25	-1.08	2.12	2.95
788	3	20	-5	7.35	1.26	-4.88	11.49	-0.89	-5.01	-1.18	2.18	2.89
772	3	20	0	7.37	1.20	-3.87	11.49	-0.49	-5.01	-1.29	2.19	2.88
776	3	20	5	7.35	1.36	-2.86	11.49	-0.17	-4.52	-1.60	2.14	2.93
780	3	20	10	7.35	1.83	-1.26	11.49	-0.05	-3.60	-2.24	1.98	3.09
784	3	20	15	7.34	3.01	1.20	11.49	-0.43	-1.53	-3.21	1.69	3.38
995	6	-10	-15	7.35	2.43	-7.40	11.49	-1.91	-8.64	1.55	2.41	4.01
990	6	-10	-10	7.35	1.78	-5.64	11.49	-1.35	-9.11	0.60	2.54	3.88
991	6	-10	-10	7.35	1.82	-5.64	11.49	-1.35	-9.11	0.56	2.53	3.89
986	6	-10	-5	7.36	1.52	-4.38	11.49	-0.58	-9.02	-0.23	2.59	3.83
960	6	-10	0	7.37	1.48	-3.24	11.49	0.16	-8.70	-1.10	2.53	3.89
961	6	-10	0	7.35	1.46	-3.28	11.49	0.15	-8.72	-1.11	2.54	3.88
966	6	-10	5	7.36	1.74	-1.85	11.49	0.73	-7.95	-2.31	2.47	3.95
978	6	-10	10	7.37	2.52	0.50	11.49	1.00	-6.91	-4.47	2.33	4.09
982	6	-10	15	7.36	4.25	4.30	11.49	0.88	-5.22	-7.39	2.01	4.41
865	6	0	-15	7.35	2.60	-7.90	11.49	-2.08	-8.40	1.47	2.36	4.12
861	6	0	-10	7.35	1.83	-5.83	11.49	-1.59	-9.08	0.32	2.46	4.02
857	6	0	-5	7.35	1.58	-4.63	11.49	-0.86	-9.33	-0.42	2.50	3.98
840	6	0	0	7.39	1.50	-3.42	11.49	-0.05	-9.14	-1.19	2.52	3.96
845	6	0	5	7.37	1.75	-2.08	11.49	0.64	-8.56	-2.25	2.42	4.06
849	6	0	10	7.36	2.44	0.02	11.49	0.98	-7.50	-3.97	2.27	4.21
853	6	0	15	7.35	4.03	3.64	11.49	0.87	-5.74	-6.69	1.97	4.51
924	6	10	-15	7.35	2.65	-8.06	11.49	-2.17	-7.83	1.73	2.45	3.97
920	6	10	-10	7.35	1.88	-5.95	11.49	-1.72	-8.59	0.37	2.56	3.86
916	6	10	-5	7.35	1.50	-4.46	11.49	-1.07	-8.92	-0.52	2.62	3.80
870	6	10	0	7.36	1.53	-3.43	11.49	-0.32	-8.91	-1.35	2.53	3.89
871	6	10	0	7.35	1.54	-3.45	11.49	-0.34	-9.09	-1.39	2.55	3.87
889	6	10	5	7.35	1.70	-2.13	11.49	0.38	-8.55	-2.30	2.55	3.87
893	6	10	10	7.36	2.18	-0.53	11.49	0.85	-7.58	-3.65	2.45	3.97
894	6	10	10	7.35	2.26	-0.41	11.49	0.85	-7.65	-3.74	2.45	3.97
899	6	10	15	7.34	3.51	2.27	11.49	0.88	-6.26	-5.90	2.19	4.23
956	6	20	-15	7.36	2.49	-7.41	11.49	-2.12	-7.13	2.00	2.49	3.74
952	6	20	-10	7.35	1.88	-5.87	11.49	-1.81	-8.30	0.74	2.62	3.61
947	6	20	-5	7.36	1.51	-4.43	11.49	-1.23	-8.65	-0.39	2.67	3.56
929	6	20	0	7.36	1.52	-3.29	11.49	-0.56	-8.67	-1.44	2.65	3.58
933	6	20	5	7.36	1.77	-1.87	11.49	0.05	-8.28	-2.73	2.58	3.65
937	6	20	10	7.36	2.23	-0.37	11.49	0.55	-7.33	-4.07	2.50	3.73
941	6	20	15	7.35	3.26	1.59	11.49	0.77	-6.35	-5.69	2.35	3.88
942	6	20	15	7.35	3.19	1.42	11.49	0.77	-6.40	-5.68	2.38	3.85

* Indicates model was close to heave stop

TABLE A1.323.1 - STABILITY DATA IN WIND AXES WITH AIR TARES

30 deg Deadrise, L/R = 0.234, Cv = 3

RUN	Trim deg	Roll deg	Yaw deg	Speed fps	X lb	Y lb	Z lb	K lb-ft	M lb-ft	N lb-ft	Heave in	TD in	
1128	*	0	-10	-15	14.69	14.48	-46.27	11.49	0.23	0.89	-29.21	0.78	3.31
1124	0	-10	-10	14.74	7.69	-30.90	11.49	0.75	1.97	-18.79	1.17	2.92	
1120	0	-10	-5	14.75	3.86	-21.98	11.49	0.16	1.13	-9.27	1.80	2.29	
1103	0	-10	0	14.74	3.04	-17.30	11.49	-0.13	1.20	-3.90	1.90	2.19	
1108	0	-10	5	14.71	3.81	-12.85	11.49	-0.59	3.61	-2.73	1.77	2.32	
1112	0	-10	10	14.73	9.29	0.65	11.49	-2.02	8.22	-4.49	0.90	3.19	
1115	0	-10	15	14.73	3.64	-10.49	11.49	0.80	-1.72	0.26	2.90	1.19	
1026	0	0	-15	14.73	5.96	-27.72	11.49	2.41	13.32	-12.54	2.49	1.66	
1022	0	0	-10	14.71	7.61	-31.91	11.49	0.24	0.23	-18.78	1.28	2.87	
1018	0	0	-5	14.74	4.01	-22.07	11.49	-0.01	1.33	-10.30	1.75	2.40	
1005	0	0	0	14.75	3.21	-17.33	11.49	-0.31	2.41	-5.53	1.81	2.34	
1009	0	0	5	14.77	3.81	-12.99	11.49	-0.79	5.46	-3.21	1.67	2.48	
1013	*	0	0	10	14.72	9.69	1.17	11.49	-2.27	9.25	-4.56	0.80	3.35
1060	0	10	-15	14.73	3.68	-21.98	11.49	1.31	8.94	-5.83	3.01	1.08	
1056	0	10	-10	14.73	6.52	-29.51	11.49	0.66	4.08	-15.39	1.73	2.36	
1052	0	10	-5	14.73	4.47	-22.01	11.49	-0.17	1.61	-8.70	1.88	2.21	
1037	0	10	0	14.73	3.63	-17.31	11.49	-0.54	1.77	-4.96	1.94	2.15	
1041	0	10	5	14.77	4.04	-12.75	11.49	-0.92	4.88	-3.43	1.78	2.31	
1046	0	10	10	14.74	8.75	-0.72	11.49	-2.17	8.85	-3.44	1.08	3.01	
1098	0	20	-15	14.75	8.10	-28.54	11.49	3.76	16.03	-11.36	2.05	1.85	
1094	0	20	-10	14.74	6.21	-25.12	11.49	1.67	12.72	-9.85	1.82	2.08	
1089	0	20	-5	14.78	4.04	-21.80	11.49	-0.25	2.15	-7.77	1.95	1.95	
1065	0	20	0	14.74	3.52	-17.62	11.49	-0.71	1.88	-4.75	2.00	1.90	
1069	0	20	5	14.78	4.06	-13.31	11.49	-1.18	3.48	-3.01	1.89	2.01	
1074	0	20	10	14.73	7.33	-3.66	11.49	-2.07	7.29	-1.05	1.45	2.45	
1078	*	0	20	15	14.73	14.39	11.90	11.49	-4.43	14.19	-1.87	0.86	3.04
834	3	-10	-15	14.75	8.06	-34.83	11.49	-0.45	-0.86	-7.91	1.85	3.41	
830	3	-10	-10	14.72	4.13	-24.00	11.49	-0.74	-4.38	-4.25	2.15	3.11	
826	3	-10	-5	14.72	2.74	-18.26	11.49	-0.44	-4.70	-2.93	2.30	2.96	
802	3	-10	0	14.75	2.70	-14.49	11.49	-0.04	-3.90	-3.01	2.38	2.88	
814	3	-10	5	14.78	3.33	-10.56	11.49	-0.00	-2.41	-4.94	2.38	2.88	
818	3	-10	10	14.77	6.02	-1.82	11.49	-0.89	1.95	-10.35	2.11	3.15	
822	3	-10	15	14.73	4.16	-8.04	11.49	2.52	-9.88	-8.32	3.39	1.87	
697	3	0	-15	14.74	8.82	-36.66	11.49	-0.52	1.51	-6.57	1.90	3.42	
690	3	0	-10	14.71	4.74	-25.51	11.49	-0.95	-2.46	-6.12	2.08	3.24	
701	3	0	-10	14.73	4.37	-24.61	11.49	-0.99	-2.94	-5.11	2.17	3.15	
706	3	0	-5	14.72	2.81	-18.75	11.49	-0.80	-4.93	-3.87	2.35	2.97	
659	3	0	0	14.75	2.80	-15.02	11.49	-0.33	-4.52	-4.23	2.21	3.11	
710	3	0	0	14.69	2.57	-14.97	11.49	-0.31	-4.72	-3.62	2.44	2.88	
663	3	0	5	14.74	3.35	-10.37	11.49	-0.06	-2.40	-5.31	2.20	3.12	
714	3	0	5	14.74	3.09	-10.82	11.49	-0.07	-2.80	-5.01	2.36	2.96	
677	3	0	10	14.72	5.99	-2.17	11.49	-0.83	1.74	-9.21	2.07	3.25	
720	3	0	10	14.73	6.08	-2.06	11.49	-0.85	1.96	-9.08	2.01	3.31	
724	3	0	15	14.75	14.20	17.36	11.49	-4.37	13.57	-15.04	1.20	4.12	

* Indicates model was close to heave stop

TABLE A1.323.2 - STABILITY DATA IN WIND AXES WITH AIR TARES

30 deg Deadrise, L/R = 0.234, Cv = 3

RUN	Trim deg	Roll deg	Yaw deg	Speed fps	X lb	Y lb	Z lb	K lb-ft	M lb-ft	N lb-ft	Heave in	TD in
766	3	10	-15	14.72	3.24	-21.88	11.49	-1.87	-4.24	0.58	3.19	2.07
762	3	10	-10	14.74	4.65	-24.62	11.49	-1.04	-1.11	-4.28	2.24	3.02
758	3	10	-5	14.72	2.90	-18.78	11.49	-1.03	-3.45	-3.94	2.43	2.83
728	3	10	0	14.71	2.42	-15.06	11.49	-0.63	-4.66	-3.91	2.53	2.73
754	3	10	5	14.72	2.82	-11.58	11.49	-0.23	-3.93	-5.39	2.53	2.73
732	3	10	10	14.71	4.78	-5.46	11.49	-0.48	-1.10	-7.76	2.26	3.00
744	3	10	10	14.77	4.80	-5.51	11.49	-0.51	-0.95	-7.94	2.30	2.96
750	3	10	15	14.73	11.06	8.95	11.49	-3.28	8.95	-13.05	1.69	3.57
797	3	20	-15	14.69	3.21	-21.26	11.49	-1.61	-2.39	1.78	3.07	2.00
793	3	20	-10	14.69	3.36	-21.05	11.49	-0.88	0.45	-0.52	2.63	2.44
789	3	20	-5	14.72	2.94	-18.54	11.49	-1.20	-3.17	-2.63	2.50	2.57
773	3	20	0	14.72	2.42	-15.01	11.49	-0.98	-3.70	-4.12	2.58	2.49
777	3	20	5	14.69	2.70	-12.09	11.49	-0.59	-4.03	-5.71	2.73	2.34
781	3	20	10	14.71	4.03	-7.44	11.49	-0.50	-3.61	-9.03	2.71	2.36
785	3	20	15	14.74	6.76	-0.99	11.49	-1.03	-2.21	-13.42	2.65	2.42
996	6	-10	-15	14.72	3.89	-23.26	11.49	-2.63	-11.42	5.09	3.49	2.93
992	6	-10	-10	14.72	2.53	-19.45	11.49	-1.84	-10.94	1.77	3.57	2.85
987	6	-10	-5	14.75	1.62	-16.56	11.49	-0.94	-9.70	-0.84	3.63	2.79
963	6	-10	0	14.73	2.09	-13.81	11.49	-0.20	-8.25	-3.32	3.35	3.07
967	6	-10	5	14.73	3.01	-9.59	11.49	0.01	-7.43	-7.94	3.35	3.07
979	6	-10	10	14.73	4.58	-4.51	11.49	-0.28	-6.03	-13.57	3.34	3.08
983	6	-10	15	14.73	9.91	8.67	11.49	-2.30	-0.56	-24.93	2.77	3.65
866	6	0	-15	14.74	4.53	-24.73	11.49	-2.33	-9.14	4.02	3.15	3.33
862	6	0	-10	14.73	2.70	-20.05	11.49	-2.08	-10.53	1.30	3.42	3.06
858	6	0	-5	14.73	2.11	-16.90	11.49	-1.24	-10.56	-1.04	3.53	2.95
842	6	0	0	14.74	1.88	-14.04	11.49	-0.39	-10.00	-3.61	3.57	2.91
846	6	0	5	14.74	2.74	-10.72	11.49	0.19	-8.75	-6.52	3.43	3.05
850	6	0	10	14.74	4.50	-5.53	11.49	0.11	-7.01	-11.80	3.31	3.17
854	6	0	15	14.70	9.15	5.92	11.49	-1.67	-2.01	-21.21	2.73	3.75
925	6	10	-15	14.74	4.96	-25.61	11.49	-2.12	-7.60	5.44	3.15	3.27
921	6	10	-10	14.77	2.63	-19.70	11.49	-2.05	-8.72	0.79	3.48	2.94
917	6	10	-5	14.78	1.96	-17.14	11.49	-1.48	-9.88	-1.19	3.70	2.72
882	6	10	0	14.75	1.89	-14.48	11.49	-0.71	-10.37	-3.69	3.80	2.62
883	6	10	0	14.73	1.86	-14.41	11.49	-0.72	-10.66	-3.83	3.73	2.69
884	6	10	0	14.72	2.01	-14.45	11.49	-0.72	-10.65	-3.82	3.73	2.69
885	6	10	0	14.71	1.89	-14.39	11.49	-0.71	-10.35	-3.69	3.81	2.61
886	6	10	0	14.73	1.92	-14.41	11.49	-0.72	-10.56	-3.84	3.73	2.69
890	6	10	5	14.71	2.49	-11.28	11.49	0.02	-10.73	-7.00	3.74	2.68
895	6	10	10	14.69	3.77	-7.64	11.49	0.44	-10.12	-11.11	3.72	2.70
896	6	10	10	14.73	3.80	-7.39	11.49	0.49	-10.33	-11.27	3.69	2.73
900	6	10	15	14.77	6.34	-1.78	11.49	0.31	-8.64	-16.60	3.47	2.95
957	6	20	-15	14.74	4.58	-25.16	11.49	-2.22	-7.89	7.05	3.36	2.87
953	6	20	-10	14.73	2.81	-19.84	11.49	-2.08	-8.26	1.62	3.48	2.75
948	6	20	-5	14.75	1.82	-16.70	11.49	-1.65	-8.72	-1.41	3.66	2.57
930	6	20	0	14.73	1.93	-14.75	11.49	-0.96	-9.89	-3.54	3.85	2.38
934	6	20	5	14.78	2.11	-12.69	11.49	-0.27	-10.75	-6.16	3.96	2.27
939	6	20	10	14.72	3.13	-9.83	11.49	0.38	-11.37	-9.76	3.98	2.25
944	6	20	15	14.75	4.89	-6.26	11.49	0.80	-11.47	-14.47	3.95	2.28

* Indicates model was close to heave stop

TABLE A1.324.1 - STABILITY DATA IN WIND AXES WITH AIR TARES

30 deg Deadrise, L/R = 0.234, Cv = 4

RUN	Trim deg	Roll deg	Yaw deg	Speed fps	X lb	Y lb	Z lb	K lb-ft	M lb-ft	N lb-ft	Heave in	TD in	
1125	*	0	-10	-10	19.69	13.40	-51.61	11.49	0.96	3.05	-36.87	0.75	3.34
1121		0	-10	-5	19.68	6.64	-38.88	11.49	0.29	5.19	-17.85	1.70	2.39
1104		0	-10	0	19.60	5.00	-30.33	11.49	-0.46	4.57	-7.40	1.85	2.24
1109		0	-10	5	19.59	7.70	-20.31	11.49	-1.46	8.74	-9.07	1.45	2.64
1116		0	-10	15	19.66	3.19	-23.15	11.49	0.48	-4.23	-1.57	3.37	0.72
1027		0	0	-15	19.61	4.56	-39.97	11.49	0.03	4.04	-6.51	3.23	0.92
1023	*	0	0	-10	19.60	12.85	-45.95	11.49	0.19	0.73	-39.14	0.72	3.43
1019		0	0	-5	19.59	6.92	-38.60	11.49	0.22	4.25	-19.51	1.64	2.51
1006		0	0	0	19.53	5.29	-30.42	11.49	-0.55	5.15	-9.89	1.79	2.36
1010		0	0	5	19.63	6.61	-22.30	11.49	-1.47	10.28	-6.39	1.63	2.52
1061		0	10	-15	19.63	4.06	-36.42	11.49	-0.25	3.45	-5.03	3.37	0.72
1057		0	10	-10	19.61	11.27	-50.39	11.49	1.88	11.77	-29.02	1.73	2.36
1053		0	10	-5	19.61	7.80	-38.96	11.49	0.15	4.93	-18.53	1.69	2.40
1038		0	10	0	19.67	6.10	-29.85	11.49	-0.78	4.23	-9.24	1.87	2.22
1042		0	10	5	19.68	6.35	-22.54	11.49	-1.38	9.60	-6.63	1.81	2.28
1047	*	0	10	10	19.68	16.29	-1.02	11.49	-3.09	13.46	-7.34	0.80	3.29
1099		0	20	-15	19.70	6.41	-38.41	11.49	2.38	13.08	-5.85	2.87	1.03
1095		0	20	-10	19.67	8.94	-41.33	11.49	2.90	22.95	-16.03	1.99	1.91
1091		0	20	-5	19.67	6.61	-37.92	11.49	-0.03	6.56	-14.18	1.93	1.97
1066		0	20	0	19.59	6.13	-30.53	11.49	-0.97	4.42	-8.72	1.96	1.94
1070		0	20	5	19.59	6.93	-22.47	11.49	-1.56	6.68	-6.24	1.86	2.04
1075		0	20	10	19.70	11.47	-7.81	11.49	-3.13	13.81	-2.52	1.56	2.34
835		3	-10	-15	19.70	13.39	-61.23	11.49	-0.05	3.04	-14.67	1.82	3.44
831		3	-10	-10	19.66	6.48	-42.02	11.49	-0.90	-3.66	-7.30	2.19	3.07
827		3	-10	-5	19.59	4.17	-31.91	11.49	-0.65	-3.86	-4.93	2.36	2.90
803		3	-10	0	19.70	3.79	-25.32	11.49	-0.28	-1.59	-5.76	2.43	2.83
815		3	-10	5	19.67	5.43	-18.32	11.49	-0.59	0.25	-9.05	2.43	2.83
819		3	-10	10	19.68	9.33	-5.19	11.49	-2.12	5.92	-17.65	2.27	2.99
823		3	-10	15	19.68	3.40	-21.82	11.49	3.37	-15.43	-10.05	3.94	1.32
696		3	0	-15	19.75	14.70	-64.42	11.49	0.14	7.63	-12.24	1.87	3.45
702		3	0	-10	19.54	6.70	-42.52	11.49	-1.08	-0.66	-9.06	2.20	3.12
703		3	0	-10	19.54	6.79	-42.63	11.49	-1.08	-0.52	-9.26	2.19	3.13
707		3	0	-5	19.68	4.14	-32.74	11.49	-1.08	-4.41	-6.25	2.41	2.91
660		3	0	0	19.60	4.44	-26.67	11.49	-0.62	-2.84	-6.99	2.21	3.11
709		3	0	0	19.63	3.73	-26.46	11.49	-0.55	-4.12	-5.76	2.49	2.83
664		3	0	5	19.65	5.46	-18.00	11.49	-0.52	0.29	-9.68	2.22	3.10
715		3	0	5	19.63	4.67	-18.93	11.49	-0.45	-1.56	-9.51	2.48	2.84
678		3	0	10	19.73	9.42	-4.79	11.49	-2.00	6.28	-16.46	2.17	3.15
721		3	0	10	19.68	9.57	-4.54	11.49	-2.03	6.53	-16.33	2.11	3.21

* Indicates model was close to heave stop

TABLE A1.324.2 - STABILITY DATA IN WIND AXES WITH AIR TARES
30 deg Deadrise, L/R = 0.234, Cv = 4

RUN	Trim deg	Roll deg	Yaw deg	Speed fps	X lb	Y lb	Z lb	K lb-ft	M lb-ft	N lb-ft	Heave in	TD in
767	3	10	-15	19.76	3.78	-36.36	11.49	-3.89	-10.10	2.19	3.45	1.81
768	3	10	-15	19.65	3.71	-36.13	11.49	-3.88	-10.36	2.19	3.47	1.79
763	3	10	-10	19.60	6.37	-41.11	11.49	-1.09	2.40	-6.41	2.40	2.86
759	3	10	-5	19.61	4.15	-32.49	11.49	-1.39	-1.84	-6.90	2.47	2.79
729	3	10	0	19.74	3.26	-26.57	11.49	-0.96	-5.49	-6.49	2.64	2.62
755	3	10	5	19.67	4.14	-20.47	11.49	-0.46	-4.87	-9.54	2.68	2.58
746	3	10	10	19.75	7.01	-11.00	11.49	-0.85	-1.43	-14.23	2.54	2.72
747	3	10	10	19.69	6.95	-11.22	11.49	-0.84	-1.43	-14.14	2.55	2.71
751	3	10	15	19.76	16.90	11.48	11.49	-5.28	15.15	-21.21	1.91	3.35
798	3	20	-15	19.62	3.62	-34.86	11.49	-3.57	-7.80	2.99	3.37	1.70
794	3	20	-10	19.64	4.19	-34.60	11.49	-1.70	-0.29	-0.57	2.85	2.22
790	3	20	-5	19.65	4.01	-31.70	11.49	-1.58	-0.75	-5.34	2.52	2.55
774	3	20	0	19.68	2.97	-26.74	11.49	-1.43	-4.05	-5.99	2.79	2.28
778	3	20	5	19.61	3.60	-22.09	11.49	-1.00	-5.78	-9.22	2.95	2.12
782	3	20	10	19.61	5.49	-16.08	11.49	-0.88	-6.23	-14.59	3.01	2.06
786	3	20	15	19.76	9.18	-7.21	11.49	-1.44	-5.71	-22.71	2.99	2.08
997	6	-10	-15	19.69	5.11	-38.46	11.49	-4.06	-17.39	8.45	3.87	2.55
993	6	-10	-10	19.64	3.18	-33.01	11.49	-2.80	-16.03	2.69	3.97	2.45
988	6	-10	-5	19.66	2.09	-28.73	11.49	-1.59	-14.20	-1.96	3.97	2.45
964	6	-10	0	19.65	2.71	-24.77	11.49	-0.58	-11.46	-5.89	3.77	2.65
968	6	-10	5	19.59	3.62	-20.23	11.49	-0.22	-10.62	-11.43	3.92	2.50
998	6	-10	5	19.63	3.59	-20.17	11.49	-0.22	-10.56	-11.41	3.91	2.51
980	6	-10	10	19.75	4.39	-18.09	11.49	0.36	-11.70	-15.47	4.28	2.14
999	6	-10	10	19.63	4.77	-16.71	11.49	0.18	-11.16	-16.60	4.17	2.25
984	6	-10	15	19.69	8.29	-8.72	11.49	-0.64	-8.84	-27.38	4.06	2.36
867	6	0	-15	19.59	6.43	-41.32	11.49	-3.55	-14.03	8.21	3.48	3.00
863	6	0	-10	19.53	3.73	-34.05	11.49	-3.11	-15.69	2.82	3.78	2.70
859	6	0	-5	19.66	2.41	-29.39	11.49	-1.96	-15.71	-1.60	3.90	2.58
843	6	0	0	19.69	2.21	-25.12	11.49	-0.85	-14.60	-6.43	3.97	2.51
847	6	0	5	19.67	3.00	-20.61	11.49	-0.16	-13.30	-11.75	4.06	2.42
851	6	0	10	19.68	4.91	-15.37	11.49	0.18	-12.58	-17.97	4.01	2.47
855	6	0	15	19.76	6.80	-11.90	11.49	0.28	-12.71	-24.08	4.24	2.24
926	6	10	-15	19.70	7.43	-43.69	11.49	-2.96	-10.63	9.79	3.36	3.06
922	6	10	-10	19.70	3.64	-34.39	11.49	-3.08	-13.00	2.31	3.80	2.62
918	6	10	-5	19.54	2.53	-29.82	11.49	-2.20	-14.47	-1.46	4.04	2.38
887	6	10	0	19.63	2.25	-26.22	11.49	-1.18	-14.83	-5.48	4.18	2.24
891	6	10	5	19.59	3.12	-21.85	11.49	-0.38	-14.68	-10.76	4.16	2.26
897	6	10	10	19.63	4.52	-17.22	11.49	0.02	-13.92	-16.91	4.20	2.22
901	6	10	15	19.90	6.75	-11.86	11.49	-0.14	-13.35	-25.22	4.15	2.27
902	6	10	15	19.90	6.74	-11.75	11.49	-0.14	-13.31	-25.19	4.14	2.28
903	6	10	15	19.93	6.74	-11.86	11.49	-0.15	-13.28	-25.15	4.15	2.27
914	6	10	15	19.59	7.43	-10.54	11.49	-0.11	-13.23	-25.47	4.13	2.29
958	6	20	-15	19.65	2.55	-32.56	11.49	-5.71	-17.50	2.87	4.75	1.48
954	6	20	-10	19.70	3.96	-34.18	11.49	-2.99	-11.22	2.85	3.72	2.51
949	6	20	-5	19.57	2.60	-29.53	11.49	-2.40	-12.71	-1.51	3.99	2.24
950	6	20	-5	19.53	2.56	-29.57	11.49	-2.41	-12.79	-1.51	3.98	2.25
931	6	20	0	19.70	2.43	-27.37	11.49	-1.49	-14.60	-4.50	4.27	1.96
935	6	20	5	19.73	2.43	-24.83	11.49	-0.55	-15.25	-8.06	4.36	1.87
940	6	20	10	19.76	3.48	-21.86	11.49	0.12	-14.77	-12.21	4.43	1.80
945	6	20	15	19.76	5.29	-18.28	11.49	0.36	-14.00	-17.46	4.43	1.80

* Indicates model was close to heave stop

TABLE A2.301 - RUDDER DATA IN WIND AXES WITH AIR TARES

Trim = 3 deg Roll = Yaw = 0 deg

30 deg Deadrise, L/R = 0.000, Cv = 1.5

RUN	Rudder deg	Speed fps	X lb	Y lb	Z lb	K lb-ft	M lb-ft	N lb-ft	Heave in	TD in
1712	-20	7.32	1.32	0.21	11.49	0.22	-6.74	0.47	2.21	3.11
1713	-20	7.32	1.35	0.17	11.49	0.21	-6.75	0.49	2.21	3.11
1709	-15	7.34	1.42	-0.29	11.49	0.40	-5.48	1.34	2.13	3.19
1706	-10	7.34	1.31	-0.10	11.49	0.33	-5.46	1.06	2.12	3.20
1703	-5	7.35	1.24	-0.04	11.49	0.27	-5.49	0.55	2.13	3.19
1700	0	7.37	1.19	-0.03	11.49	0.22	-5.63	0.06	2.16	3.16
1724	5	7.33	1.29	0.72	11.49	-0.01	-5.44	-0.52	2.14	3.18
1719	10	7.33	1.31	0.96	11.49	-0.12	-5.50	-1.02	2.15	3.17
1718	15	7.33	1.51	1.20	11.49	-0.22	-5.46	-1.28	2.15	3.17

TABLE A2.303 - RUDDER DATA IN WIND AXES WITH AIR TARES

Trim = 3 deg Roll = Yaw = 0 deg

30 deg Deadrise, L/R = 0.000, Cv = 3

RUN	Rudder deg	Speed fps	X lb	Y lb	Z lb	K lb-ft	M lb-ft	N lb-ft	Heave in	TD in
1714	-20	14.74	2.54	-0.56	11.49	0.52	-13.03	0.93	3.27	2.05
1710	-15	14.76	3.35	-2.45	11.49	1.24	-4.78	4.91	2.62	2.70
1707	-10	14.76	2.86	-2.21	11.49	1.09	-4.83	4.02	2.62	2.70
1704	-5	14.77	2.59	-1.10	11.49	0.65	-4.82	2.10	2.64	2.68
1701	0	14.74	2.57	-0.23	11.49	0.24	-4.81	0.21	2.63	2.69
1723	5	14.76	2.65	1.18	11.49	-0.30	-4.84	-1.93	2.63	2.69
1720	10	14.76	2.99	2.22	11.49	-0.74	-4.89	-3.71	2.63	2.69
1717	15	14.74	3.57	2.55	11.49	-0.90	-5.13	-4.52	2.64	2.68

TABLE A2.304 - RUDDER DATA IN WIND AXES WITH AIR TARES

Trim = 3 deg Roll = Yaw = 0 deg

30 deg Deadrise, L/R = 0.000, Cv = 4

RUN	Rudder deg	Speed fps	X lb	Y lb	Z lb	K lb-ft	M lb-ft	N lb-ft	Heave in	TD in
1715	-20	19.62	3.10	-0.59	11.49	0.69	-17.43	1.14	3.92	1.40
1711	-15	19.62	5.19	-4.45	11.49	2.15	-4.63	8.72	2.85	2.47
1708	-10	19.62	4.30	-3.45	11.49	1.67	-4.49	6.90	2.86	2.46
1705	-5	19.65	3.93	-1.92	11.49	0.98	-4.40	3.63	2.85	2.47
1702	0	19.65	3.87	-0.37	11.49	0.28	-4.55	0.49	2.91	2.41
1722	5	19.62	3.95	2.05	11.49	-0.71	-4.57	-3.41	2.88	2.44
1721	10	19.62	4.53	3.64	11.49	-1.40	-4.71	-6.47	2.90	2.42
1716	15	19.62	5.59	4.48	11.49	-1.77	-5.18	-7.98	2.90	2.42

APPENDIX B

TABLE B.1 CHRONOLOGICAL RUN DIRECTORY

Run	Radius ft	Trim deg	Roll deg	Yaw deg	Speed fps
Start of Tests at 32 ft Radius					
1-76 Calibration checks and preliminary runs					
DZ	77	32	0	0	0.00
	78	32	0	0	7.38
DR	79	32	3	0	0.00
DZ	80	32	3	0	0.00
	81	32	3	0	7.36
	82	32	3	0	14.67
	83	32	3	0	19.61
DR	84	32	3	0	0.00
DZ	85	32	3	0	0.00
PHOTO	86	32	3	0	7.36 for 87
	87	32	3	0	7.36
	88	32	3	0	14.71
89-100 Calibration checks					
	101	32	3	0	5 14.71
102-104 Calibration checks					
	105	32	3	0	5 14.67
	106	32	3	0	5 19.60
	107	32	3	0	5 7.36
DR	108	32	3	0	10 0.00
DR	109	32	3	0	10 0.00
DZ	110	32	3	0	10 0.00
	111	32	3	0	10 7.35
	112	32	3	0	10 14.68
	113	32	3	0	10 19.59
DZ	114	32	3	0	15 0.00
	115	32	3	0	15 7.36
	116	32	3	0	15 14.68
	117	32	3	0	15 19.59
DR	118	32	3	0	-5 0.00
PHOTO	119	32	3	0	-5 7.38 for 120
	120	32	3	0	-5 7.38
	121	32	3	0	-5 14.72
	122	32	3	0	-5 19.63
DZ	123	32	3	0	-10 0.00
	124	32	3	0	-10 7.37
	125	32	3	0	-10 14.71
	126	32	3	0	-10 19.62
DR	127	32	3	0	-15 0.00
DZ	128	32	3	0	-15 0.00
	129	32	3	0	-15 7.36
	130	32	3	0	-15 14.68
	131	32	3	0	-15 19.58
	132	32	3	0	15 14.67
	133	32	3	0	15 19.61
134	Instrumentation fault				
	135	32	3	0	15 7.36

* Indicates model was close to heave stop

TABLE B.2 CHRONOLOGICAL RUN DIRECTORY

	Run	Radius ft	Trim deg	Roll deg	Yaw deg	Speed fps
DR	136	32	3	10	0	0.00
DZ	137	32	3	10	0	0.00
	138	32	3	10	0	7.37
	139-140	Instrumentation fault				
	141	32	3	10	0	14.68
	142	Instrumentation fault				
	143	32	3	10	0	19.61
	144	32	3	10	5	7.37
DZ	145	32	3	10	5	0.00
	146	32	3	10	5	7.37
	147	32	3	10	5	14.71
	148	32	3	10	5	19.61
DZ	149	32	3	10	10	0.00
	150	32	3	10	10	7.37
	151	32	3	10	10	14.70
	152	Instrumentation fault				
	153	32	3	10	10	19.62
	154-168	Calibration checks				
DZ	169	32	3	10	0	0.00
	170	32	3	10	15	7.37
	172	Instrumentation fault				
	173	32	3	10	15	7.37
	174	32	3	10	15	7.36
	175	32	3	10	15	14.69
	176-177	Instrumentation fault				
	178	32	3	10	15	19.63
DZ	179	32	3	10	-5	0.00
	180	32	3	10	-5	7.37
	181	32	3	10	-5	14.72
	182	32	3	10	-5	19.64
DZ	183	32	3	10	-10	0.00
	184	32	3	10	-10	7.37
	185	32	3	10	-10	14.73
	186	32	3	10	-10	19.63
	187	Instrumentation fault				
	188	32	3	10	-15	7.37
	189	Instrumentation fault				
DZ	190	32	3	10	-15	0.00
	191	32	3	10	-15	14.73
	192	32	3	10	-15	19.66
	193	32	3	10	-15	19.65
DR	194	32	3	10	-15	19.65
DR	195	32	3	20	0	0.00
DZ	196	32	3	20	0	0.00
	197	32	3	20	0	7.38
	198-199	Instrumentation fault				
	200	32	3	20	0	14.72
	201	32	3	20	0	19.75
	202	32	3	20	0	19.72
DZ	203	32	3	20	5	0.00
	204	32	3	20	5	7.29
205	Instrumentation fault					

* Indicates model was close to heave stop

TABLE B.3 CHRONOLOGICAL RUN DIRECTORY

	Run	Radius ft	Trim deg	Roll deg	Yaw deg	Speed fps
	206	32	3	20	5	14.66
	207	32	3	20	5	19.68
DZ	208	32	3	20	10	0.00
DZ	209	32	3	20	10	0.00
	210	32	3	20	10	7.32
	211	32	3	20	10	14.74
	212	32	3	20	10	19.62
DZ	213	32	3	20	15	0.00
	214	32	3	20	15	7.35
	215	32	3	20	15	14.98
	216	32	3	20	15	14.75
217-226	Calibration checks					
DZ	227	32	3	20	15	0.00
228	Instrumentation fault					
	229	32	3	20	15	19.59
DZ	230	32	3	20	-5	0.00
	231	32	3	20	-5	7.36
	232	32	3	20	-5	14.74
	233	32	3	20	-5	19.55
DZ	234	32	3	20	-10	0.00
	235	32	3	20	-10	7.34
	236	32	3	20	-10	14.77
237	Instrumentation fault					
	238	32	3	20	-10	19.63
DZ	239	32	3	20	-15	0.00
	240	32	3	20	-15	7.35
	241	32	3	20	-15	14.72
242	Instrumentation fault					
	243	32	3	20	-15	19.62
DR	244	32	3	-10	0	0.00
DZ	245	32	3	-10	0	0.00
	246	32	3	-10	0	7.38
	247	32	3	-10	0	14.74
	248	32	3	-10	0	19.63
	249	32	3	-10	5	7.37
DZ	250	32	3	-10	5	0.00
	251	32	3	-10	5	7.37
DR	252	32	3	-10	5	0.00
	253	32	3	-10	5	7.37
	254	32	3	-10	5	14.74
	255	32	3	-10	5	19.61
DZ	256	32	3	-10	10	0.00
	257	32	3	-10	10	7.37
	258	32	3	-10	10	14.73
	259	32	3	-10	10	19.66
DZ	260	32	3	-10	15	0.00
	261	32	3	-10	15	7.37
	262	32	3	-10	15	14.77
263-264	Instrumentation fault					
	265	32	3	-10	15	19.64
DZ	266	32	3	-10	-5	0.00
	267	32	3	-10	-5	7.35

* Indicates model was close to heave stop

TABLE B.4 CHRONOLOGICAL RUN DIRECTORY

	Run	Radius ft	Trim deg	Roll deg	Yaw deg	Speed fps	
	268	Instrumentation fault					
	269	32	3	-10	-5	14.75	
	270	32	3	-10	-5	19.63	
DZ	271	32	3	-10	-10	0.00	
	272	32	3	-10	-10	7.36	
	273	32	3	-10	-10	14.74	
	274	32	3	-10	-10	19.60	
DZ	275	32	3	-10	-15	0.00	
	276	32	3	-10	-15	7.36	
	277	32	3	-10	-15	14.73	
	278	32	3	-10	-15	19.60	
	279-288	Calibration checks					
DZ	289	32	6	0	0	0.00	
	290	32	6	0	0	7.39	
DR	291	32	6	0	0	0.00	
	292	32	6	0	0	14.78	
	293	32	6	0	0	19.66	
	294	32	6	0	5	7.37	
DZ	295	32	6	0	5	0.00	
	296	32	6	0	5	14.76	
	297	32	6	0	5	19.65	
DZ	298	32	6	0	10	0.00	
	299	32	6	0	10	7.37	
	300	32	6	0	10	14.76	
	301	32	6	0	10	19.66	
DZ	302	32	6	0	15	0.00	
	303	32	6	0	15	7.37	
	304	32	6	0	15	14.72	
	305	Instrumentation fault					
	306	32	6	0	15	19.67	
DR	307	32	6	0	15	0.00	
DZ	308	32	6	0	15	0.00	
	309	32	6	0	15	7.38	
DR	310	32	6	0	15	0.00	
DZ	311	32	6	0	-5	0.00	
	312	32	6	0	-5	7.38	
	313-314	Instrumentation fault					
	315	32	6	0	-5	14.76	
	316	32	6	0	-5	19.67	
DZ	317	32	6	0	-10	0.00	
	318	32	6	0	-10	7.37	
	319	32	6	0	-10	14.77	
DR	320	32	6	0	-10	0.00	
	321	Instrumentation fault					
	322	32	6	0	-10	19.63	
DZ	323	32	6	0	-15	0.00	
	324	Instrumentation fault					
	325	32	6	0	-15	7.37	
	326	32	6	0	-15	14.75	
	327	32	6	0	-15	19.61	
DR	328	32	6	10	0	0.00	
DZ	329	32	6	10	0	0.00	

* Indicates model was close to heave stop

TABLE B.5 CHRONOLOGICAL RUN DIRECTORY

	Run	Radius ft	Trim deg	Roll deg	Yaw deg	Speed fps
	330	32	6	10	0	7.37
	331	32	6	10	0	14.75
332	Instrumentation fault					
	333	32	6	10	0	19.64
DZ	334	32	6	10	5	0.00
	335	32	6	10	5	7.38
	336	32	6	10	5	14.77
	337	32	6	10	5	19.67
DZ	338	32	6	10	10	0.00
	339	32	6	10	10	7.38
	340	32	6	10	10	14.76
	341	32	6	10	10	19.69
DZ	342	32	6	10	15	0.00
	343	32	6	10	15	7.38
	344	32	6	10	15	14.76
	345	32	6	10	15	19.69
DZ	346	32	6	10	-5	0.00
	347	32	6	10	-5	7.37
348-354	Calibration checks					
DZ	355	32	6	10	-5	0.00
DR	356	32	6	10	-5	0.00
	357	32	6	10	-5	14.78
	358	32	6	10	-5	19.65
DZ	359	32	6	10	-10	0.00
	360	32	6	10	-10	7.37
	361	32	6	10	-10	14.86
	362	32	6	10	-10	19.62
	363	32	6	10	-10	14.72
DZ	364	32	6	10	-15	0.00
	365	32	6	10	-15	7.36
	366	32	6	10	-15	14.74
367	Instrumentation fault					
	368	32	6	10	-15	19.64
DZ	369	32	6	10	15	0.00
	370	32	6	10	15	19.63
DR	371	32	6	20	0	0.00
DZ	372	32	6	20	0	0.00
	373	32	6	20	0	7.36
	374	32	6	20	0	14.77
	375	32	6	20	0	19.68
DZ	376	32	6	20	5	0.00
	377	32	6	20	5	7.36
	378	32	6	20	5	14.74
	379	32	6	20	5	19.64
	380	32	6	20	5	19.66
DZ	381	32	6	20	10	0.00
	382	32	6	20	10	7.38
	383	32	6	20	10	14.77
	384	32	6	20	10	19.64
DZ	385	32	6	20	15	0.00
	386	32	6	20	15	7.36
	387	32	6	20	15	14.72

* Indicates model was close to heave stop

TABLE B.6 CHRONOLOGICAL RUN DIRECTORY

	Run	Radius ft	Trim deg	Roll deg	Yaw deg	Speed fps
	388	32	6	20	15	19.63
DZ	389	32	6	20	-5	0.00
	390	32	6	20	-5	7.36
	391	32	6	20	-5	14.72
	392	32	6	20	-5	19.63
DZ	393	32	6	20	-10	0.00
	394	32	6	20	-10	7.36
	395	32	6	20	-10	14.69
	396	32	6	20	-10	19.59
DZ	397	32	6	20	-15	0.00
	398	32	6	20	-15	7.36
DR	399	32	6	20	-15	0.00
	400	32	6	20	-15	14.73
	401	32	6	20	-15	19.60
DR	402	32	6	-10	0	0.00
DZ	403	32	6	-10	0	0.00
	404	32	6	-10	0	7.36
	405	32	6	-10	0	14.71
	406	32	6	-10	0	19.64
DZ	407	32	6	-10	5	0.00
	408	32	6	-10	5	7.38
	409	32	6	-10	5	14.75
	410	32	6	-10	5	19.70
DZ	411	32	6	-10	10	0.00
	412	32	6	-10	10	7.37
	413	32	6	-10	10	14.75
	414	32	6	-10	10	19.65
415-423	Calibration checks					
DZ	424	32	6	-10	15	0.00
	425	32	6	-10	15	7.38
	426	32	6	-10	15	14.74
	427	32	6	-10	15	19.65
DZ	428	32	6	-10	-5	0.00
	429	32	6	-10	-5	7.37
	430	32	6	-10	-5	14.73
	431	32	6	-10	-5	19.65
DZ	432	32	6	-10	-10	0.00
	433	32	6	-10	-10	7.37
	434	32	6	-10	-10	14.73
	435	32	6	-10	-10	19.66
DZ	436	32	6	-10	-15	0.00
	437	32	6	-10	-15	7.36
	438	32	6	-10	-15	14.75
	439	32	6	-10	-15	19.67
DR	440	32	6	-10	-15	0.00
DZ	441	32	0	0	0	0.00
DR	442	32	0	0	0	0.00
	443	32	0	0	0	7.38
	444	32	0	0	0	14.74
	445	32	0	0	0	19.65
DZ	446	32	0	0	5	0.00
447	Instrumentation fault					

* Indicates model was close to heave stop

TABLE B.7 CHRONOLOGICAL RUN DIRECTORY

	Run	Radius ft	Trim deg	Roll deg	Yaw deg	Speed fps
	448	32	0	0	5	7.38
	449	32	0	0	5	14.76
	450	32	0	0	5	19.66
DZ	451	32	0	0	10	0.00
	452	32	0	0	10	7.37
	453 *	32	0	0	10	14.76
DZ	454	32	0	0	15	0.00
	455 *	32	0	0	15	7.37
DZ	456	32	0	0	-5	0.00
	457	32	0	0	-5	7.36
	458	32	0	0	-5	14.73
	459	32	0	0	-5	19.61
DZ	460	32	0	0	-10	0.00
	461	32	0	0	-10	7.36
	462 *	32	0	0	-10	14.72
DZ	463	32	0	0	-15	0.00
	464 *	32	0	0	-15	7.35
DR	465	32	0	10	0	0.00
DZ	466	32	0	10	0	0.00
	467	32	0	10	0	7.36
	468	32	0	10	0	14.73
	469	32	0	10	0	19.63
470-475	Calibration checks					
DZ	476	32	0	0	0	0.00
DR	477	32	0	0	0	0.00
DZ	478	32	0	10	5	0.00
	479	32	0	10	5	7.38
	480	32	0	10	5	14.75
	481	32	0	10	5	19.62
DZ	482	32	0	10	10	0.00
	483	32	0	10	10	7.36
	484	32	0	10	10	14.74
DZ	485	32	0	10	15	0.00
	486	32	0	10	15	7.37
DZ	487	32	0	10	-5	0.00
	488	32	0	10	-5	7.38
	489	32	0	10	-5	14.75
	490	32	0	10	-5	19.65
DZ	491	32	0	10	-10	0.00
	492	32	0	10	-10	7.37
	493	32	0	10	-10	14.75
	494	32	0	10	-10	19.64
DZ	495	32	0	10	-15	0.00
	496	32	0	10	-15	7.36
	497	32	0	10	-15	14.73
	498	32	0	10	-15	19.69
DR	499	32	0	10	-15	0.00
DZ	500	32	0	20	0	0.00
	501	32	0	20	0	7.39
	502	32	0	20	0	14.77
	503	32	0	20	0	19.67
DZ	504	32	0	20	5	0.00

* Indicates model was close to heave stop

TABLE B.8 CHRONOLOGICAL RUN DIRECTORY

	Run	Radius ft	Trim deg	Roll deg	Yaw deg	Speed fps
	505	32	0	20	5	7.38
	506	32	0	20	5	14.76
	507	32	0	20	5	19.67
DZ	508	32	0	20	10	0.00
	509	32	0	20	10	7.37
	510	32	0	20	10	14.75
511	Aborted					
DZ	512	32	0	20	15	0.00
	513	32	0	20	15	7.37
DZ	514	32	0	20	-5	0.00
	515	32	0	20	-5	7.37
	516	32	0	20	-5	14.74
	517	32	0	20	-5	19.61
DZ	518	32	0	20	-10	0.00
	519	32	0	20	-10	7.37
	520	32	0	20	-10	14.74
	521	32	0	20	-10	19.66
DZ	522	32	0	20	-15	0.00
	523	32	0	20	-15	7.38
	524	32	0	20	-15	14.75
	525	32	0	20	-15	19.62
DR	526	32	0	-10	0	0.00
DZ	527	32	0	-10	0	0.00
	528	32	0	-10	0	7.37
	529	32	0	-10	0	14.74
	530	32	0	-10	0	19.66
DZ	531	32	0	-10	5	0.00
	532	32	0	-10	5	7.37
	533	32	0	-10	5	14.75
	534	32	0	-10	5	19.64
DZ	535	32	0	-10	10	0.00
	536	32	0	-10	10	7.37
	537	32	0	-10	10	14.74
538-547	Calibration checks					
DZ	548	32	0	-10	0	0.00
PHOTO	549	32	0	-10	15	7.38 for 550
	550	32	0	-10	15	7.38
DZ	551	32	0	-10	15	0.00
	552	32	0	-10	15	14.74
	553	32	0	-10	15	19.61
	554 *	32	0	-10	10	19.61
DZ	555	32	0	-10	-5	0.00
	556	32	0	-10	-5	7.37
557	Instrumentation fault					
	558	32	0	-10	-5	14.75
	559	32	0	-10	-5	19.58
DZ	560	32	0	-10	-10	0.00
	561	32	0	-10	-10	7.36
	562 *	32	0	-10	-10	14.75
DZ	563	32	0	-10	-15	0.00
	564 *	32	0	-10	-15	7.35
565-619	Air tare tests					

* Indicates model was close to heave stop

TABLE B.9 CHRONOLOGICAL RUN DIRECTORY

Run	Radius ft	Trim deg	Roll deg	Yaw deg	Speed fps	
Start of Tests at 16 ft Radius						
620-656 Calibration checks and preliminary runs						
DZ	657	16	3	0	0	0.00
	658	16	3	0	0	7.36
	659	16	3	0	0	14.75
	660	16	3	0	0	19.60
DZ	661	16	3	0	5	0.00
	662	16	3	0	5	7.35
	663	16	3	0	5	14.74
	664	16	3	0	5	19.65
665-674 Calibration checks						
DZ	675	16	3	0	10	0.00
	676	16	3	0	10	7.36
	677	16	3	0	10	14.72
	678	16	3	0	10	19.73
	679	16	3	0	15	0.00
	680	16	3	0	15	7.35
DR	681	16	3	0	15	0.00
DR	682	16	3	0	15	0.00
DZ	683	16	3	0	15	0.00
DZ	684	16	3	0	-5	0.00
	685	16	3	0	-5	7.35
DR	686	16	3	0	-5	0.00
DR	687	16	3	0	-5	0.00
DZ	688	16	3	0	-10	0.00
	689	16	3	0	-10	7.36
	690	16	3	0	-10	14.71
DR	691	16	3	0	-10	0.00
DZ	692	16	3	0	-15	0.00
DR	693	16	3	0	-15	0.00
DR	694	16	3	0	-15	0.00
DR	695	16	3	0	-15	0.00
	696	16	3	0	-15	19.75
	697	16	3	0	-15	14.74
	698	16	3	0	-15	7.36
DZ	699	16	3	0	-10	0.00
	700	16	3	0	-10	7.36
	701	16	3	0	-10	14.73
	702	16	3	0	-10	19.54
	703	16	3	0	-10	19.54
DZ	704	16	3	0	-5	0.00
	705	16	3	0	-5	7.36
	706	16	3	0	-5	14.72
	707	16	3	0	-5	19.68
DZ	708	16	3	0	0	0.00
	709	16	3	0	0	19.63
	710	16	3	0	0	14.69
	711	16	3	0	0	7.36
DZ	712	16	3	0	5	0.00
	713	16	3	0	5	7.36

* Indicates model was close to heave stop

TABLE B.10 CHRONOLOGICAL RUN DIRECTORY

	Run	Radius ft	Trim deg	Roll deg	Yaw deg	Speed fps
	714	16	3	0	5	14.74
	715	16	3	0	5	19.63
DR	716	16	3	0	5	0.00
DR	717	16	3	0	5	0.00
DZ	718	16	3	0	10	0.00
	719	16	3	0	10	7.38
	720	16	3	0	10	14.73
	721	16	3	0	10	19.68
	722	16	3	0	15	0.00
	723	16	3	0	15	7.36
	724	16	3	0	15	14.75
DR	725	16	3	0	15	0.00
DZ	726	16	3	10	0	0.00
	727	16	3	10	0	7.36
	728	16	3	10	0	14.71
	729	16	3	10	0	19.74
DZ	730	16	3	10	10	0.00
	731	16	3	10	10	7.35
	732	16	3	10	10	14.71
733-742	Calibration checks					
DZ	743	16	3	10	10	0.00
	744	16	3	10	10	14.77
DR	745	16	3	10	10	0.00
	746	16	3	10	10	19.75
	747	16	3	10	10	19.69
DZ	748	16	3	10	15	0.00
	749	16	3	10	15	7.37
	750	16	3	10	15	14.73
	751	16	3	10	15	19.76
DZ	752	16	3	10	5	0.00
	753	16	3	10	5	7.36
	754	16	3	10	5	14.72
	755	16	3	10	5	19.67
DZ	756	16	3	10	-5	0.00
	757	16	3	10	-5	7.35
	758	16	3	10	-5	14.72
	759	16	3	10	-5	19.61
DZ	760	16	3	10	-10	0.00
	761	16	3	10	-10	7.36
	762	16	3	10	-10	14.74
	763	16	3	10	-10	19.60
DZ	764	16	3	10	-15	0.00
	765	16	3	10	-15	7.35
	766	16	3	10	-15	14.72
	767	16	3	10	-15	19.76
	768	16	3	10	-15	19.65
DR	769	16	3	20	0	0.00
DR	770	16	3	20	0	0.00
DZ	771	16	3	20	0	0.00
	772	16	3	20	0	7.37
	773	16	3	20	0	14.72
	774	16	3	20	0	19.68

* Indicates model was close to heave stop

TABLE B.11 CHRONOLOGICAL RUN DIRECTORY

	Run	Radius ft	Trim deg	Roll deg	Yaw deg	Speed fps
DZ	775	16	3	20	5	0.00
	776	16	3	20	5	7.35
	777	16	3	20	5	14.69
	778	16	3	20	5	19.61
DZ	779	16	3	20	10	0.00
	780	16	3	20	10	7.35
	781	16	3	20	10	14.71
	782	16	3	20	10	19.61
DZ	783	16	3	20	15	0.00
	784	16	3	20	15	7.34
	785	16	3	20	15	14.74
	786	16	3	20	15	19.76
DZ	787	16	3	20	-5	0.00
	788	16	3	20	-5	7.35
	789	16	3	20	-5	14.72
	790	16	3	20	-5	19.65
DZ	791	16	3	20	-10	0.00
	792	16	3	20	-10	7.35
	793	16	3	20	-10	14.69
	794	16	3	20	-10	19.64
DZ	795	16	3	20	-15	0.00
	796	16	3	20	-15	7.35
	797	16	3	20	-15	14.69
	798	16	3	20	-15	19.62
DR	799	16	3	-10	0	0.00
DZ	800	16	3	-10	0	0.00
	801	16	3	-10	0	7.36
	802	16	3	-10	0	14.75
	803	16	3	-10	0	19.70
804-812	Calibration checks					
	813	16	3	-10	5	7.38
	814	16	3	-10	5	14.78
	815	16	3	-10	5	19.67
DZ	816	16	3	-10	10	0.00
	817	16	3	-10	10	7.39
	818	16	3	-10	10	14.77
	819	16	3	-10	10	19.68
DZ	820	16	3	-10	15	0.00
	821	16	3	-10	15	7.38
	822	16	3	-10	15	14.73
	823	16	3	-10	15	19.68
DZ	824	16	3	-10	-5	0.00
	825	16	3	-10	-5	7.37
	826	16	3	-10	-5	14.72
	827	16	3	-10	-5	19.59
DZ	828	16	3	-10	-10	0.00
	829	16	3	-10	-10	7.36
	830	16	3	-10	-10	14.72
	831	16	3	-10	-10	19.66
DZ	832	16	3	-10	-15	0.00
	833	16	3	-10	-15	7.37
	834	16	3	-10	-15	14.75

* Indicates model was close to heave stop

TABLE B.12 CHRONOLOGICAL RUN DIRECTORY

	Run	Radius ft	Trim deg	Roll deg	Yaw deg	Speed fps
	835	16	3	-10	-15	19.70
	836-838	Calibration checks				
DZ	839	16	6	0	0	0.00
	840	16	6	0	0	7.39
DR	841	16	6	0	0	0.00
	842	16	6	0	0	14.74
	843	16	6	0	0	19.69
DZ	844	16	6	0	5	0.00
	845	16	6	0	5	7.37
	846	16	6	0	5	14.74
	847	16	6	0	5	19.67
DZ	848	16	6	0	10	0.00
	849	16	6	0	10	7.36
	850	16	6	0	10	14.74
	851	16	6	0	10	19.68
DZ	852	16	6	0	15	0.00
	853	16	6	0	15	7.35
	854	16	6	0	15	14.70
	855	16	6	0	15	19.76
DZ	856	16	6	0	-5	0.00
	857	16	6	0	-5	7.35
	858	16	6	0	-5	14.73
	859	16	6	0	-5	19.66
DZ	860	16	6	0	-10	0.00
	861	16	6	0	-10	7.35
	862	16	6	0	-10	14.73
	863	16	6	0	-10	19.53
DZ	864	16	6	0	-15	0.00
	865	16	6	0	-15	7.35
	866	16	6	0	-15	14.74
	867	16	6	0	-15	19.59
DR	868	16	6	10	0	0.00
DZ	869	16	6	10	0	0.00
	870	16	6	10	0	7.36
	871	16	6	10	0	7.35
	872-880	Calibration checks				
DZ	881	16	6	10	0	0.00
	882	16	6	10	0	14.75
	883	16	6	10	0	14.73
	884	16	6	10	0	14.72
	885	16	6	10	0	14.71
	886	16	6	10	0	14.73
	887	16	6	10	0	19.63
DZ	888	16	6	10	5	0.00
	889	16	6	10	5	7.35
	890	16	6	10	5	14.71
	891	16	6	10	5	19.59
DZ	892	16	6	10	10	0.00
	893	16	6	10	10	7.36
	894	16	6	10	10	7.35
	895	16	6	10	10	14.69
	896	16	6	10	10	14.73

* Indicates model was close to heave stop

TABLE B.13 CHRONOLOGICAL RUN DIRECTORY

	Run	Radius ft	Trim deg	Roll deg	Yaw deg	Speed fps
	897	16	6	10	10	19.63
DZ	898	16	6	10	15	0.00
	899	16	6	10	15	7.34
	900	16	6	10	15	14.77
	901	16	6	10	15	19.90
	902	16	6	10	15	19.90
	903	16	6	10	15	19.93
	904-911	Calibration checks				
DZ	912	16	6	10	0	0.00
DZ	913	16	6	10	15	0.00
	914	16	6	10	15	19.59
DZ	915	16	6	10	-5	0.00
	916	16	6	10	-5	7.35
	917	16	6	10	-5	14.78
	918	16	6	10	-5	19.54
DZ	919	16	6	10	-10	0.00
	920	16	6	10	-10	7.35
	921	16	6	10	-10	14.77
	922	16	6	10	-10	19.70
DZ	923	16	6	10	-15	0.00
	924	16	6	10	-15	7.35
	925	16	6	10	-15	14.74
	926	16	6	10	-15	19.70
DR	927	16	6	20	0	0.00
DZ	928	16	6	20	0	0.00
	929	16	6	20	0	7.36
	930	16	6	20	0	14.73
	931	16	6	20	0	19.70
DZ	932	16	6	20	5	0.00
	933	16	6	20	5	7.36
	934	16	6	20	5	14.78
	935	16	6	20	5	19.73
DZ	936	16	6	20	10	0.00
	937	16	6	20	10	7.36
DR	938	16	6	20	10	7.36
	939	16	6	20	10	14.72
	940	16	6	20	10	19.76
	941	16	6	20	15	7.35
	942	16	6	20	15	7.35
DZ	943	16	6	20	15	0.00
	944	16	6	20	15	14.75
	945	16	6	20	15	19.76
DZ	946	16	6	20	-5	0.00
	947	16	6	20	-5	7.36
	948	16	6	20	-5	14.75
	949	16	6	20	-5	19.57
	950	16	6	20	-5	19.53
DZ	951	16	6	20	-10	0.00
	952	16	6	20	-10	7.35
	953	16	6	20	-10	14.73
	954	16	6	20	-10	19.70
DZ	955	16	6	20	-15	0.00

* Indicates model was close to heave stop

TABLE B.14 CHRONOLOGICAL RUN DIRECTORY

	Run	Radius ft	Trim deg	Roll deg	Yaw deg	Speed fps
	956	16	6	20	-15	7.36
	957	16	6	20	-15	14.74
	958	16	6	20	-15	19.65
DR	961	16	6	-10	0	0.00
	960	16	6	-10	0	7.37
	961	16	6	-10	0	7.35
DZ	962	16	6	-10	0	0.00
	963	16	6	-10	0	14.73
	964	16	6	-10	0	19.65
DZ	965	16	6	-10	5	0.00
	966	16	6	-10	5	7.36
	967	16	6	-10	5	14.73
	968	16	6	-10	5	19.59
969-976	Calibration checks					
DZ	977	16	6	-10	10	0.00
	978	16	6	-10	10	7.37
	979	16	6	-10	10	14.73
	980	16	6	-10	10	19.75
DZ	981	16	6	-10	15	0.00
	982	16	6	-10	15	7.36
	983	16	6	-10	15	14.73
	984	16	6	-10	15	19.69
DZ	985	16	6	-10	-5	0.00
	986	16	6	-10	-5	7.36
	987	16	6	-10	-5	14.75
	988	16	6	-10	-5	19.66
DZ	989	16	6	-10	-10	0.00
	990	16	6	-10	-10	7.35
	991	16	6	-10	-10	7.35
	992	16	6	-10	-10	14.72
	993	16	6	-10	-10	19.64
DZ	994	16	6	-10	-15	0.00
	995	16	6	-10	-15	7.35
	996	16	6	-10	-15	14.72
	997	16	6	-10	-15	19.69
	998	16	6	-10	5	19.63
	999	16	6	-10	10	19.63
1000-1002	Calibration checks					
DZ	1003	16	0	0	0	0.00
	1004	16	0	0	0	7.37
	1005	16	0	0	0	14.75
	1006	16	0	0	0	19.53
DZ	1007	16	0	0	5	0.00
	1008	16	0	0	5	7.37
	1009	16	0	0	5	14.77
	1010	16	0	0	5	19.63
DZ	1011	16	0	0	10	0.00
	1012	16	0	0	10	7.36
	1013 *	16	0	0	10	14.72
DZ	1014	16	0	0	15	0.00
	1015 *	16	0	0	15	7.35
DZ	1016	16	0	0	-5	0.00

* Indicates model was close to heave stop

TABLE B.15 CHRONOLOGICAL RUN DIRECTORY

	Run	Radius ft	Trim deg	Roll deg	Yaw deg	Speed fps
	1017	16	0	0	-5	7.35
	1018	16	0	0	-5	14.74
	1019	16	0	0	-5	19.59
DZ	1020	16	0	0	-10	0.00
	1021	16	0	0	-10	7.35
	1022	16	0	0	-10	14.71
	1023 *	16	0	0	-10	19.60
DZ	1024	16	0	0	-15	0.00
	1025	16	0	0	-15	7.35
	1026	16	0	0	-15	14.73
	1027	16	0	0	-15	19.61
	1028-1034	Calibration checks				
DZ	1035	16	0	10	0	0.00
	1036	16	0	10	0	7.37
	1037	16	0	10	0	14.73
	1038	16	0	10	0	19.67
DZ	1039	16	0	10	5	0.00
	1040	16	0	10	5	7.36
	1041	16	0	10	5	14.77
	1042	16	0	10	5	19.68
DZ	1043	16	0	10	10	0.00
	1044	16	0	10	10	7.35
	1045	16	0	10	10	7.37
	1046	16	0	10	10	14.74
	1047 *	16	0	10	10	19.68
DZ	1048	16	0	10	15	0.00
	1049	16	0	10	15	7.36
DZ	1050	16	0	10	-5	0.00
	1051	16	0	10	-5	7.36
	1052	16	0	10	-5	14.73
	1053	16	0	10	-5	19.61
DZ	1054	16	0	10	-10	0.00
	1055	16	0	10	-10	7.35
	1056	16	0	10	-10	14.73
	1057	16	0	10	-10	19.61
DZ	1058	16	0	10	-15	0.00
	1059	16	0	10	-15	7.36
	1060	16	0	10	-15	14.73
	1061	16	0	10	-15	19.63
DR	1062	16	0	20	0	0.00
DZ	1063	16	0	20	0	0.00
	1064	16	0	20	0	7.36
	1065	16	0	20	0	14.74
	1066	16	0	20	0	19.59
DZ	1067	16	0	20	5	0.00
	1068	16	0	20	5	7.38
	1069	16	0	20	5	14.78
	1070	16	0	20	5	19.59
	1071	16	0	20	10	7.36
DZ	1072	16	0	20	10	0.00
	1073	16	0	20	10	7.36
	1074	16	0	20	10	14.73

* Indicates model was close to heave stop

TABLE B.16 CHRONOLOGICAL RUN DIRECTORY

Run	Radius ft	Trim deg	Roll deg	Yaw deg	Speed fps
1075	16	0	20	10	19.70
DZ 1076	16	0	20	15	0.00
1077	16	0	20	15	7.35
1078 *	16	0	20	15	14.73
1079-1084	Calibration checks				
DZ 1085	16	0	0	0	0.00
DR 1086	16	0	20	-5	0.00
DZ 1087	16	0	20	-5	0.00
1088	16	0	20	-5	7.37
1089	16	0	20	-5	14.78
DR 1090	16	0	20	-5	0.00
1091	16	0	20	-5	19.67
DZ 1092	16	0	20	-10	0.00
1093	16	0	20	-10	7.36
1094	16	0	20	-10	14.74
1095	16	0	20	-10	19.67
DZ 1096	16	0	20	-15	0.00
1097	16	0	20	-15	7.37
1098	16	0	20	-15	14.75
1099	16	0	20	-15	19.70
DR 1100	16	0	-10	0	0.00
DZ 1101	16	0	-10	0	0.00
1102	16	0	-10	0	7.36
1103	16	0	-10	0	14.74
1104	16	0	-10	0	19.60
DZ 1105	16	0	-10	5	0.00
1106	16	0	-10	5	7.36
DR 1107	16	0	-10	5	0.00
1108	16	0	-10	5	14.71
1109	16	0	-10	5	19.59
DZ 1110	16	0	-10	10	0.00
1111	16	0	-10	10	7.36
1112	16	0	-10	10	14.73
DZ 1113	16	0	-10	15	0.00
1114	16	0	-10	15	7.36
1115	16	0	-10	15	14.73
1116	16	0	-10	15	19.66
DZ 1117	16	0	-10	-5	0.00
1118	16	0	-10	-5	7.36
DR 1119	16	0	-10	-5	0.00
1120	16	0	-10	-5	14.75
1121	16	0	-10	-5	19.68
DZ 1122	16	0	-10	-10	0.00
1123	16	0	-10	-10	7.36
1124	16	0	-10	-10	14.74
1125 *	16	0	-10	-10	19.69
DZ 1126	16	0	-10	-15	0.00
1127	16	0	-10	-15	7.35
1128 *	16	0	-10	-15	14.69
1129 *	16	0	-10	-15	7.36
1130-1252	Air tare tests				

* Indicates model was close to heave stop

TABLE B.17 CHRONOLOGICAL RUN DIRECTORY

Run	Radius ft	Trim deg	Roll deg	Yaw deg	Speed fps	
Start of Straight Course Tests						
1253-1300 Calibration checks and preliminary runs						
DZ	1301	INF	3	0	0.00	
	1302	INF	3	0	7.32	
	1303	INF	3	0	7.31	
	1304	INF	3	0	17.83	
	1305	INF	3	0	14.77	
	1306	INF	3	0	19.72	
DZ	1307	INF	3	0	0.00	
	1308	INF	3	0	7.31	
DZ	1309	INF	3	0	0.00	
	1310	INF	3	5	7.34	
	1311	INF	3	5	14.77	
	1312	INF	3	5	19.75	
DZ	1313	INF	3	10	0.00	
	1314	INF	3	10	7.35	
DR	1315	INF	3	10	0.00	
	1316	INF	3	10	14.74	
	1317	INF	3	10	19.32	
DZ	1318	INF	3	15	0.00	
	1319	INF	3	15	7.35	
	1320	INF	3	15	14.71	
	1321	INF	3	15	19.62	
	1322	INF	3	10	19.72	
DR	1323	INF	3	10	0.00	
DZ	1324	INF	3	10	0.00	
	1325	INF	3	10	7.33	
	1326	INF	3	10	14.74	
	1327	INF	3	10	19.72	
DZ	1328	INF	3	10	5	0.00
	1329	INF	3	10	5	7.34
	1330	INF	3	10	5	14.74
	1331	INF	3	10	5	19.72
DZ	1332	INF	3	10	10	0.00
	1333	INF	3	10	10	7.33
	1334	INF	3	10	10	14.72
	1335	INF	3	10	10	19.68
DZ	1336	INF	3	10	15	0.00
	1337	INF	3	10	15	7.33
	1338	INF	3	10	15	14.71
	1339	INF	3	10	15	19.65
	1340	INF	3	10	15	19.68
DR	1341	INF	3	20	0	0.00
DZ	1342	INF	3	20	0	0.00
	1343	INF	3	20	0	7.34
	1344	INF	3	20	0	14.76
	1345	INF	3	20	0	19.75
1346-1358 Calibration checks						
DZ	1359	INF	3	20	5	0.00
	1360	INF	3	20	5	7.45

* Indicates model was close to heave stop

TABLE B.18 CHRONOLOGICAL RUN DIRECTORY

	Run	Radius ft	Trim deg	Roll deg	Yaw deg	Speed fps
	1361	INF	3	20	5	14.77
	1362	INF	3	20	5	19.78
DZ	1363	INF	3	20	10	0.00
	1364	INF	3	20	10	7.35
	1365	INF	3	20	10	14.77
	1366	INF	3	20	10	19.75
DZ	1367	INF	3	20	15	0.00
	1368	INF	3	20	15	7.34
	1369	INF	3	20	15	14.74
	1370	INF	3	20	15	7.43
	1371	INF	3	20	15	14.81
	1372	INF	3	20	15	19.78
DR	1373	INF	3	-10	0	0.00
DZ	1374	INF	3	-10	0	0.00
	1375	INF	3	-10	0	7.45
	1376	INF	3	-10	0	14.85
	1377	INF	3	-10	0	19.81
	1378	INF	3	-10	5	7.38
DZ	1379	INF	3	-10	5	0.00
	1380	INF	3	-10	5	14.79
	1381	INF	3	-10	5	19.78
DZ	1382	INF	3	-10	10	0.00
	1383	INF	3	-10	10	7.36
	1384	INF	3	-10	10	14.77
	1385	INF	3	-10	10	19.75
DZ	1386	INF	3	-10	15	0.00
	1387	INF	3	-10	15	7.34
	1388	INF	3	-10	15	14.77
	1389	INF	3	-10	15	19.78
	1390-1404	Calibration checks				
DZ	1405	INF	6	0	0	0.00
	1406	INF	6	0	0	7.34
	1407	INF	6	0	0	14.76
	1408	INF	6	0	0	19.75
DZ	1409	INF	6	0	5	0.00
	1410	INF	6	0	5	7.43
	1411	INF	6	0	5	14.81
	1412	INF	6	0	5	19.78
	1413-1437	Calibration checks				
DZ	1438	INF	6	0	0	0.00
	1439	INF	6	0	5	19.81
DZ	1440	INF	6	0	10	0.00
	1441	INF	6	0	10	7.40
	1442	INF	6	0	10	14.76
	1443	INF	6	0	10	19.68
DZ	1444	INF	6	0	15	0.00
	1445-1454	Calibration checks				
DZ	1455	INF	6	0	15	0.00
	1456	INF	6	0	15	7.45
	1457	INF	6	0	15	14.77
	1458	INF	6	0	15	19.68
DR	1459	INF	6	10	0	0.00

* Indicates model was close to heave stop

TABLE B.19 CHRONOLOGICAL RUN DIRECTORY

	Run	Radius ft	Trim deg	Roll deg	Yaw deg	Speed fps
DZ	1460	INF	6	10	0	0.00
	1461	INF	6	10	0	7.38
	1462	INF	6	10	0	14.74
	1463	INF	6	10	0	19.68
DZ	1464	INF	6	10	5	0.00
	1465	INF	6	10	5	7.36
	1466	INF	6	10	5	14.74
	1467	INF	6	10	5	19.65
DZ	1468	INF	6	10	10	0.00
	1469	INF	6	10	10	7.35
	1470	INF	6	10	10	14.72
	1471	INF	6	10	10	19.65
DZ	1472	INF	6	10	15	0.00
	1473	INF	6	10	15	7.34
	1474	INF	6	10	15	14.71
	1475	INF	6	10	15	19.65
DR	1476	INF	6	20	0	0.00
DZ	1477	INF	6	20	0	0.00
	1478	INF	6	20	0	7.46
	1479	INF	6	20	0	14.81
	1480	INF	6	20	0	19.72
DZ	1481	INF	6	20	5	0.00
	1482	INF	6	20	5	7.38
	1483	INF	6	20	5	14.76
	1484	INF	6	20	5	19.68
DZ	1485	INF	6	20	10	0.00
	1486	INF	6	20	10	7.37
	1487	INF	6	20	10	14.74
	1488	INF	6	20	10	19.68
DZ	1489	INF	6	20	15	0.00
PHOTO	1490	INF	6	20	15	14.77 for 1491
	1491	INF	6	20	15	14.77
	1492	INF	6	20	15	19.68
DR	1493	INF	6	-10	0	0.00
DZ	1494	INF	6	-10	0	0.00
	1495	INF	6	-10	0	7.44
	1496	INF	6	-10	0	14.79
	1497	INF	6	-10	0	19.72
DZ	1498	INF	6	-10	5	0.00
	1499	INF	6	-10	5	7.37
	1500	INF	6	-10	5	14.74
	1501	INF	6	-10	5	19.68
DZ	1502	INF	6	-10	10	0.00
	1503	INF	6	-10	10	7.35
	1504	INF	6	-10	10	14.72
	1505	INF	6	-10	10	19.65
DZ	1506	INF	6	-10	15	0.00
	1507	INF	6	-10	15	7.35
	1508	INF	6	-10	15	14.71
	1509	INF	6	-10	15	19.65
DR	1510	INF	0	0	0	0.00
DZ	1511	INF	0	0	0	0.00

* Indicates model was close to heave stop

TABLE B.20 CHRONOLOGICAL RUN DIRECTORY

	Run	Radius ft	Trim deg	Roll deg	Yaw deg	Speed fps
	1512	INF	0	0	0	7.35
	1513	INF	0	0	0	14.72
DR	1514	INF	0	0	0	0.00
	1515	INF	0	0	0	19.65
	1516-1526	Calibration checks				
DZ	1527	INF	0	0	5	0.00
	1528	INF	0	0	5	7.38
DR	1529	INF	0	0	5	0.00
	1530	INF	0	0	5	14.74
	1531	INF	0	0	5	19.65
DZ	1532	INF	0	0	10	0.00
	1533	INF	0	0	10	7.36
	1534	INF	0	0	10	14.69
DZ	1535	INF	0	0	15	0.00
	1536	INF	0	0	15	7.40
DR	1537	INF	0	10	0	0.00
DR	1538	INF	0	10	0	0.00
DZ	1539	INF	0	10	0	0.00
	1540	INF	0	10	0	7.35
	1541	INF	0	10	0	14.71
	1542	INF	0	10	0	19.62
DZ	1543	INF	0	10	5	0.00
	1544	INF	0	10	5	7.35
	1545	INF	0	10	5	14.71
	1546	INF	0	10	5	19.62
DZ	1547	INF	0	10	10	0.00
	1548	INF	0	10	10	7.34
	1549	INF	0	10	10	14.69
DZ	1550	INF	0	10	15	0.00
	1551	INF	0	10	15	7.32
DR	1552	INF	0	20	0	0.00
DZ	1553	INF	0	20	0	0.00
	1554	INF	0	20	0	7.34
	1555	INF	0	20	0	14.79
	1556	INF	0	20	0	19.68
DZ	1557	INF	0	20	5	0.00
	1558	INF	0	20	5	7.38
	1559	INF	0	20	5	14.74
	1560	INF	0	20	5	19.65
DZ	1561	INF	0	20	10	0.00
	1562	INF	0	20	10	7.36
	1563	INF	0	20	10	14.71
	1564	INF	0	20	10	19.62
DZ	1565	INF	0	20	15	0.00
	1566	INF	0	20	15	7.36
	1567	INF	0	20	15	14.67
	1568	INF	0	20	15	19.53
DR	1569	INF	0	20	15	0.00
DR	1570	INF	0	-10	0	0.00
DZ	1571	INF	0	-10	0	0.00
	1572	INF	0	-10	0	7.36
	1573	INF	0	-10	0	14.72

* Indicates model was close to heave stop

TABLE B.21 CHRONOLOGICAL RUN DIRECTORY

	Run	Radius ft	Trim deg	Roll deg	Yaw deg	Speed fps
	1574	INF	0	-10	0	19.65
DZ	1575	INF	0	-10	5	0.00
	1576	INF	0	-10	5	7.35
	1577	INF	0	-10	5	14.72
	1578	INF	0	-10	5	19.62
DZ	1579	INF	0	-10	10	0.00
	1580	INF	0	-10	10	7.34
	1581	INF	0	-10	10	14.71
	1582	INF	0	-10	10	19.62
DZ	1583	INF	0	-10	15	0.00
	1584	INF	0	-10	15	7.34
	1585	INF	0	-10	15	14.69
	1586	INF	0	-10	15	19.65
DR	1587	INF	-2	0	0	0.00
DZ	1588	INF	-2	0	0	0.00
	1589	INF	-2	0	0	7.35
	1590	INF	-2	0	0	14.71
DR	1591	INF	-2	0	0	0.00
	1592 *	INF	-2	0	0	19.59
DZ	1593	INF	-2	0	5	0.00
	1594	INF	-2	0	5	7.35
	1595	INF	-2	0	5	14.71
	1596 *	INF	-2	0	5	19.59
	1597-1606	Calibration checks				
DZ	1607	INF	-2	0	10	0.00
	1608	INF	-2	0	10	7.45
	1609 *	INF	-2	0	10	14.74
DZ	1610	INF	-2	0	15	0.00
	1611 *	INF	-2	0	15	7.34
DR	1612	INF	-2	10	0	0.00
DR	1613	INF	-2	10	0	0.00
DZ	1614	INF	-2	10	0	0.00
	1615	INF	-2	10	0	7.34
	1616	INF	-2	10	0	14.71
	1617 *	INF	-2	10	0	19.62
DZ	1618	INF	-2	10	5	0.00
	1619	INF	-2	10	5	7.34
	1620	INF	-2	10	5	14.71
DZ	1621	INF	-2	10	10	0.00
	1622	INF	-2	10	10	7.34
	1623 *	INF	-2	10	10	14.67
DZ	1624	INF	-2	10	15	0.00
	1625 *	INF	-2	10	15	7.32
DR	1626	INF	-2	10	15	0.00
DR	1627	INF	-2	10	15	0.00
DZ	1628	INF	-2	20	0	0.00
	1629	INF	-2	20	0	7.46
	1630	INF	-2	20	0	14.79
	1631 *	INF	-2	20	0	19.65
DZ	1632	INF	-2	20	5	0.00
	1633	INF	-2	20	5	7.38
	1634	INF	-2	20	5	14.72

* Indicates model was close to heave stop

TABLE B.22 CHRONOLOGICAL RUN DIRECTORY

	Run	Radius ft	Trim deg	Roll deg	Yaw deg	Speed fps
DZ	1635	INF	-2	20	10	0.00
	1636	INF	-2	20	10	7.37
	1637 *	INF	-2	20	10	14.69
DZ	1638	INF	-2	20	15	0.00
	1639 *	INF	-2	20	15	7.34
DR	1640	INF	-2	-10	0	0.00
DZ	1641	INF	-2	-10	0	0.00
	1642	INF	-2	-10	0	7.36
	1643	INF	-2	-10	0	14.72
	1644 *	INF	-2	-10	0	19.62
DZ	1645	INF	-2	-10	5	0.00
	1646	INF	-2	-10	5	7.35
	1647	INF	-2	-10	5	14.71
DZ	1648	INF	-2	-10	10	0.00
	1649	INF	-2	-10	10	7.35
	1650 *	INF	-2	-10	10	14.67
DZ	1651	INF	-2	-10	15	0.00
	1652	INF	-2	-10	15	7.34
DR	1653	INF	3	0	0	0.00
	1654	INF	3	0	0	14.72
	1655	INF	3	0	5	14.72
	1656	INF	3	0	10	14.72
	1657	INF	3	0	15	14.67
DR	1658	INF	3	10	0	0.00
	1659	INF	3	10	5	14.74
	1660	INF	3	10	0	14.74
	1661	INF	3	10	10	14.72
	1662	INF	3	10	15	14.69
DR	1663	INF	3	20	0	0.00
	1664	INF	3	20	0	14.74
	1665	INF	3	20	5	14.74
	1666	INF	3	20	10	14.72
	1667	INF	3	20	15	14.71
	1668	INF	3	-10	5	14.79
	1689	INF	3	0	0	0.00
	1669-1692	Airtare tests				

* Indicates model was close to heave stop

TABLE B.23 CHRONOLOGICAL RUN DIRECTORY

Run	Radius ft	Trim deg	Roll deg	Yaw deg	Speed fps
-----	--------------	-------------	-------------	------------	--------------

Straight Course Rudder Tests
(Zero roll and yaw)

1693-1699 Calibration checks for rudder tests

1700	INF	3	0	0	7.37
1701	INF	3	0	0	14.74
1702	INF	3	0	0	19.65
1703	INF	3	0	-5	7.35
1704	INF	3	0	-5	14.77
1705	INF	3	0	-5	19.65
1706	INF	3	0	-10	7.34
1707	INF	3	0	-10	14.76
1708	INF	3	0	-10	19.62
1709	INF	3	0	-15	7.34
1710	INF	3	0	-15	14.76
1711	INF	3	0	-15	19.62
1712	INF	3	0	-20	7.32
1713	INF	3	0	-20	7.32
1714	INF	3	0	-20	14.74
1715	INF	3	0	-20	19.62
1716	INF	3	0	15	19.62
1717	INF	3	0	15	14.74
1718	INF	3	0	15	7.33
1719	INF	3	0	10	7.33
1720	INF	3	0	10	14.76
1721	INF	3	0	10	19.62
1722	INF	3	0	5	19.62
1723	INF	3	0	5	14.76
1724	INF	3	0	5	7.33

END OF TESTS

APPENDIX C

AXES SYSTEMS AND AIR TARES
 Axes Coordinate Systems and Transformations

The model forces and moments were measured in balance axes with origin fixed in the model at a point 22.5 inches forward of the transom and 4.15 inches above the keel. The balance axes system rotates with the model in yaw and remains parallel to the water surface, with the z-axis vertical. This system is illustrated in Sketch C1 where the positive sense of the forces and moments is indicated. The hydrodynamic forces and moments acting on the model that are measured in balance axes are denoted by suffix "m". The vertical force, Z_m , is positive upward.

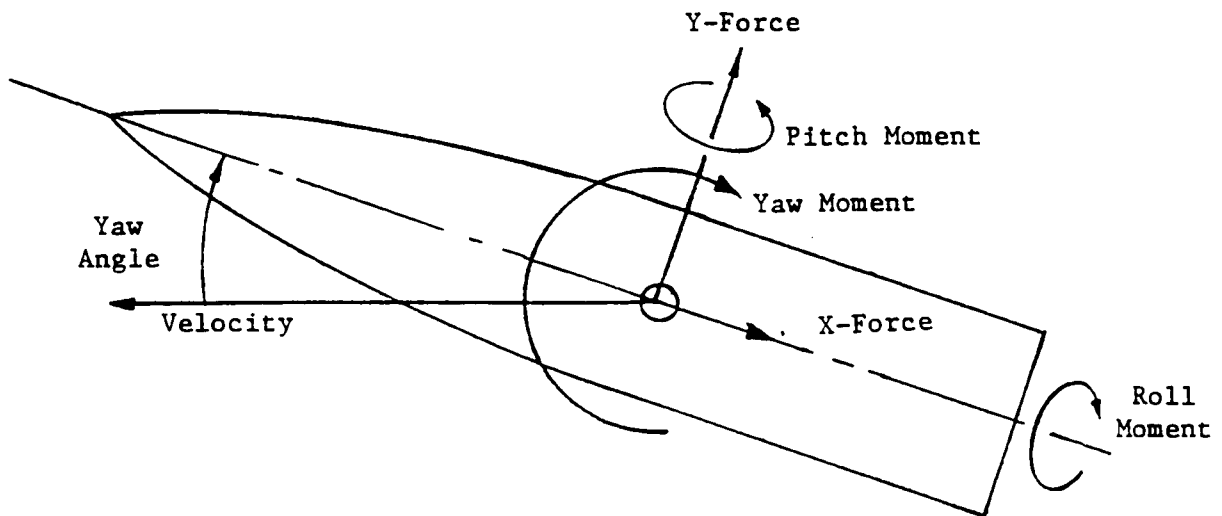

Sketch C1 - Measurement Axes

- ϕ roll angle, positive starboard-side down
- θ trim angle, positive bow up
- ψ yaw angle, positive bow to starboard
- X_m longitudinal force, positive aft
- Y_m side force, positive to starboard
- Z_m vertical force, positive upward
- K_m roll moment, positive starboard-side down
- M_m pitch moment, positive bow up
- N_m yaw moment, positive bow to starboard

Transformation to Wind Axes

The "raw" data is reported in a wind axes with the same origin fixed in the model. The wind axes system is also oriented parallel to the water surface, however the x-axis is parallel to the resultant velocity vector and does not yaw with the model. The forces and moments in the wind axes system have the same positive senses as in the balance axes. The wind axes system is shown in Sketch C2:

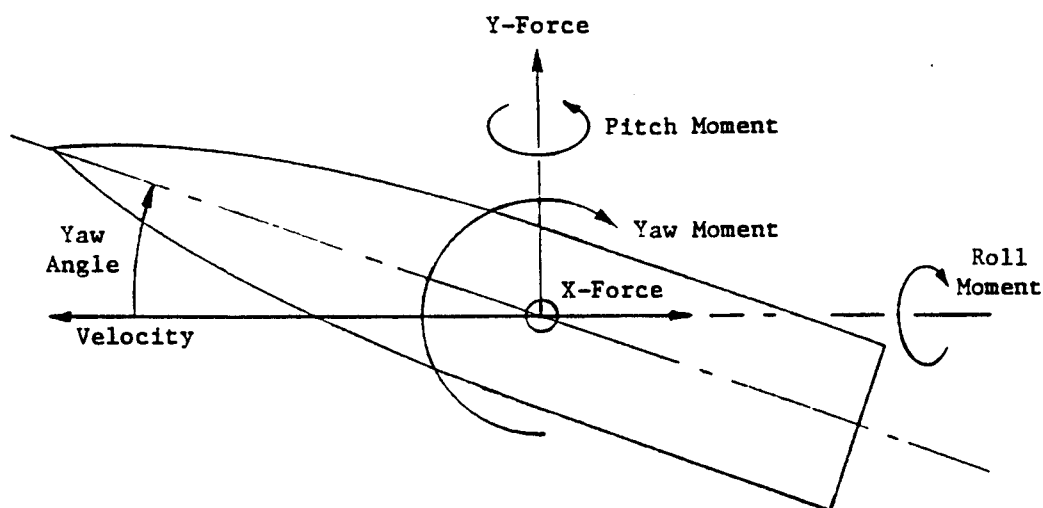

Sketch C2 - Wind Axes

The forces and moments in wind axes are denoted by suffix "w". The transformation equations from balance axes to wind axes are given below:

$$X_w = X_m \cos\psi + Y_m \sin\psi \quad (C.1)$$

$$Y_w = Y_m \cos\psi - X_m \sin\psi \quad (C.2)$$

$$Z_w = Z_m = \text{model displacement} \quad (C.3)$$

$$K_w = K_m \cos\psi - M_m \sin\psi \quad (C.4)$$

$$M_w = M_m \cos\psi + K_m \sin\psi \quad (C.5)$$

$$N_w = N_m \quad (C.6)$$

Transformation to Body Axes at the Tow Point

The body axes system is a rational right-handed system fixed in the boat with the same origin as the wind axes. This axes system moves with the model in roll, pitch, and yaw. Sketch C3 indicates the positive sense of the

forces and moments. While the sense of the moments has not changed, it may be noted that now the axial force is positive forward and the normal force is positive from the deck towards the keel.

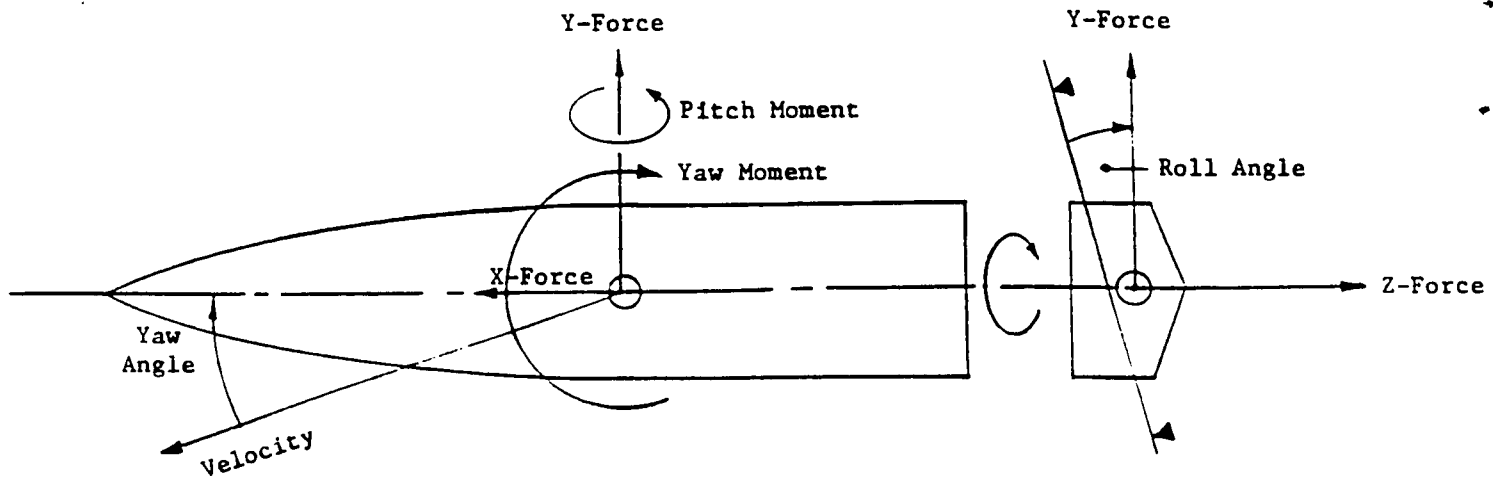

Sketch C3 - Body Axes

A preliminary transformation is made to turn the wind axes system into a rational set by reversing the signs of X_w and Z_w :

$$X_r = - X_w \quad (C.7)$$

$$Z_r = - Z_w \quad (C.8)$$

The forces and moments in body axes are denoted by suffix "b":

$$X_b = X_r \cos\theta \cos\psi + Y_w \cos\theta \sin\psi - Z_r \sin\theta \quad (C.9)$$

$$Y_b = X_r (\sin\phi \sin\theta \cos\psi - \cos\phi \sin\psi) + Y_w (\sin\phi \sin\theta \sin\psi + \cos\phi \cos\psi) + Z_r \sin\phi \cos\theta \quad (C.10)$$

$$Z_b = X_r (\cos\phi \sin\theta \cos\psi + \sin\phi \sin\psi) + Y_w (\cos\phi \sin\theta \sin\psi - \sin\phi \cos\psi) + Z_r \cos\phi \cos\theta \quad (C.11)$$

$$K_b = K_w \cos\theta \cos\psi + M_w \cos\theta \sin\psi - N_r \sin\theta \quad (C.12)$$

$$M_b = K_w (\sin\phi \sin\theta \cos\psi - \cos\phi \sin\psi) + M_w (\cos\phi \sin\theta \sin\psi - \sin\phi \cos\psi) + N_w \cos\phi \cos\theta \quad (C.13)$$

$$N_b = K_w (\cos\phi \sin\theta \cos\psi + \sin\phi \sin\psi) + M_w (\cos\phi \sin\theta \sin\psi - \sin\phi \cos\psi) + N_w \cos\phi \cos\theta \quad (C.14)$$

Translation of Body Axes from Tow Point to New Origin

The final step needed is to translate the origin of the body axes system from the tow point to the keel at transom. This system is illustrated in Sketch C4

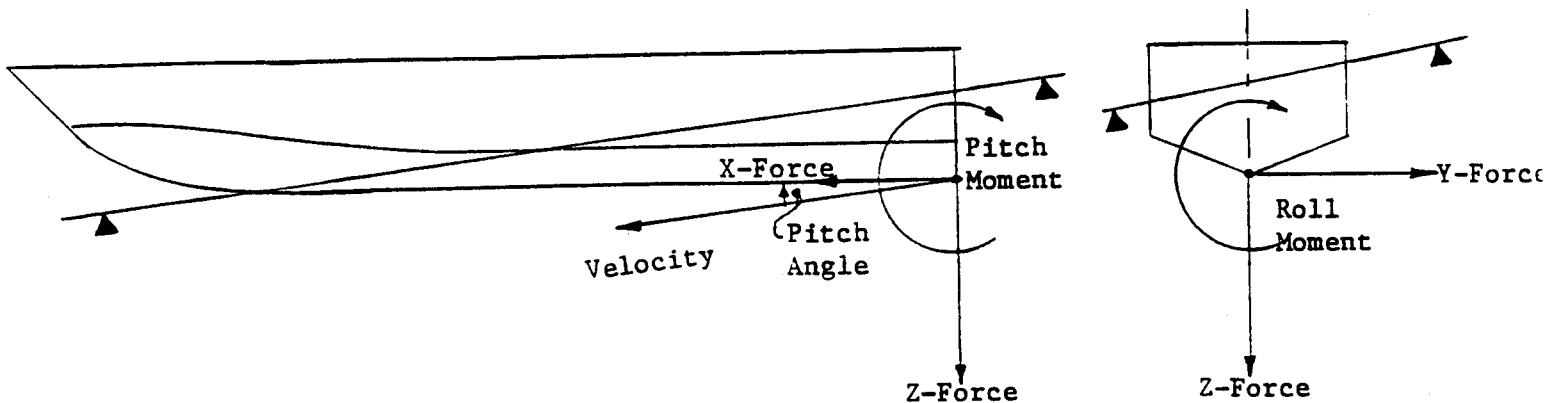

Sketch C4 - Body Axes at Keel at Transom

The forces and moments in the translated body axes system are denoted by suffix "bt":

$$X_{bt} = X_b \quad (C.15)$$

$$Y_{bt} = Y_b \quad (C.16)$$

$$Z_{bt} = Z_b \quad (C.17)$$

$$K_{bt} = K_b + z_t Y_b - y_t Z_b \quad (C.18)$$

$$M_{bt} = M_b - z_t X_b + x_t Z_b \quad (C.19)$$

$$N_{bt} = N_b + y_t X_b - x_t Y_b \quad (C.20)$$

where (x_t, y_t, z_t) is the position of the new origin in the original reference system, i.e. relative to the pivot. The new origin, defined by the keel at transom, is 1.875 ft aft of the tow point, and 0.3458 ft below it. Both origins lie in the plane of symmetry. Therefore the position of the new origin is given by:

$$(x_t, y_t, z_t) = (-1.875, 0, 0.3458) \quad (C.20)$$

Air Tares

The forces and moments measured with the model in the air were transferred to wind axes and plotted. It was confirmed that these data varied as the square of the speed. Accordingly the results were adjusted to a speed of 19.64 fps by multiplying them by the square of the ratio (19.64/V), where V was the test speed. From plots of this expanded data it was determined that the air tares varied with yaw angle and were essentially independent of trim and roll. Regression analyses of the expanded data resulted in the following expressions for the air tares at 19.64 fps:

Air Tare Equations for the 30 degree Deadrise Model

16 ft Radius	32 ft Radius	Straight Course
X = -0.10	X = 0.12	X = 0.18
Y = -29.81 + 0.0247 ψ	Y = -14.90 + 0.0124 ψ	Y = 0.04 + 0.0162 ψ
K = -0.77 + 0.0044 ψ - 0.0027 ψ^2	K = -0.40 + 0.0040 ψ - 0.0014 ψ^2	K = 0.06 + 0.0027 ψ
M = -0.24 + 0.1400 ψ	M = -0.12 + 0.0700 ψ	M = 0.0
N = -0.92 + 0.0099 ψ	N = -0.46 + 0.0049 ψ	N = -0.03 + 0.0121 ψ

As a check, the forces and moments calculated from these equations were subtracted from the air tares and the resulting residuals examined. The residuals were sufficiently small to show that a satisfactory fit had been obtained. The averages of the residuals, and their standard deviations, are shown in the following table at each condition:

Air Tare Residuals for the 30 degree Deadrise Model

	16 ft Radius		32 ft Radius		Straight Course	
	Average	Standard deviation	Average	Standard deviation	Average	Standard deviation
X	-0.024	0.105	0.001	0.009	0.003	0.041
Y	0.043	0.120	0.006	0.030	0.003	0.089
K	0.010	0.024	0.014	0.016	0.015	0.029
M	0.013	0.059	0.014	0.025	0.010	0.035
N	0.010	0.042	-0.008	0.014	-0.002	0.016

The following test condition has been selected to illustrate the removal of the air tares:

Deadrise	30 degrees
Radius	32 ft
Speed, Cv	3
Trim	3 degrees
Roll	10 degrees
Yaw	10 degrees

By reference to the Run Directory, Table 2.313, this condition corresponds to Run 151. The raw data are given in Table A1.313.2, and Run 151 is shown to have a speed of 14.70 fps, hence the 19.64 fps air tares must be multiplied by a factor of 0.560. The air tares given by the Air Tare Equations are multiplied by the factor of 0.560 and subtracted from the raw data. The data without air tares are given in Table 5.313.2. The air tare correction process for this one specific run is illustrated by the following table:

Raw Data with air tares from Table A1.313.2 Run 151	Air Tare corrections from A.T. Equations multiplied by 0.560	Wind Axes Data without air tares from Table 5.313.2 Run 151
X = 4.52	0.07	4.45
Y = 1.08	-8.28	9.36
K = -0.06	-0.27	0.22
M = -2.00	0.33	-2.33
N = -4.38	-0.23	-4.15