



Defense Nuclear Agency
Alexandria, VA 22310-3398



DNA-TR-93-187

Material Modeling in the CRALE Code Users' Manual

Shel Schuster
The Titan Corporation
Titan Research & Technology Division
9410 Topanga Canyon Blvd, Suite 104
Chatsworth, CA 91311-5771

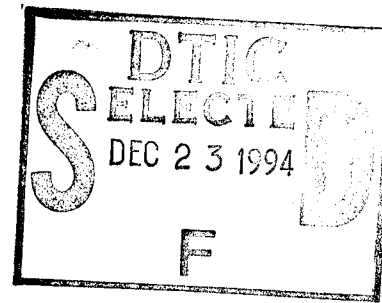

December 1994

Technical Report

CONTRACT No. DNA 001-93-C-0055

Approved for public release;
distribution is unlimited.

19941219 071

Approved for public release; distribution is unlimited.

Destroy this report when it is no longer needed. Do not return to sender.

PLEASE NOTIFY THE DEFENSE NUCLEAR AGENCY,
ATTN: CSTI, 6801 TELEGRAPH ROAD, ALEXANDRIA, VA
22310-3398, IF YOUR ADDRESS IS INCORRECT, IF YOU
WISH IT DELETED FROM THE DISTRIBUTION LIST, OR
IF THE ADDRESSEE IS NO LONGER EMPLOYED BY YOUR
ORGANIZATION.



DISTRIBUTION LIST UPDATE

This mailer is provided to enable DNA to maintain current distribution lists for reports. (We would appreciate your providing the requested information.)

- Add the individual listed to your distribution list.
- Delete the cited organization/individual.
- Change of address.

NOTE:
Please return the mailing label from the document so that any additions, changes, corrections or deletions can be made easily. For distribution cancellation or more information call DNA/IMAS (703) 325-1036.

NAME: _____

ORGANIZATION: _____

OLD ADDRESS	CURRENT ADDRESS
_____	_____
_____	_____
_____	_____

TELEPHONE NUMBER: () _____

DNA PUBLICATION NUMBER/TITLE	CHANGES/DELETIONS/ADDITIONS, etc.) <small>(Attach Sheet if more Space is Required)</small>
_____	_____
_____	_____
_____	_____

DNA OR OTHER GOVERNMENT CONTRACT NUMBER: _____

CERTIFICATION OF NEED-TO-KNOW BY GOVERNMENT SPONSOR (if other than DNA): _____

SPONSORING ORGANIZATION: _____

CONTRACTING OFFICER OR REPRESENTATIVE: _____

SIGNATURE: _____

CUT HERE AND RETURN



DEFENSE NUCLEAR AGENCY
ATTN: IMAS
6801 TELEGRAPH ROAD
ALEXANDRIA, VA 22310-3398

DEFENSE NUCLEAR AGENCY
ATTN: IMAS
6801 TELEGRAPH ROAD
ALEXANDRIA, VA 22310-3398

REPORT DOCUMENTATION PAGE			Form Approved OMB No 0704-0188	
Public reporting burden for this collection of information is estimated to average 1 hour per response, including the time for reviewing instructions, searching existing data sources, gathering and maintaining the data needed, and completing and reviewing the collection of information. Send comments regarding this burden estimate or any other aspect of this collection of information, including suggestions for reducing this burden, to Washington Headquarters Services, Directorate for Information Operations and Reports, 1215 Jefferson Davis Highway, Suite 1204, Arlington, VA 22202-4302, and to the Office of Management and Budget, Paperwork Reduction Project (0704-0188), Washington, DC 20503				
1. AGENCY USE ONLY (Leave blank)	2. REPORT DATE 941201	3. REPORT TYPE AND DATES COVERED Technical 930312 - 931212		
4. TITLE AND SUBTITLE Material Modeling in the CRALE Code Users' Manual		5. FUNDING NUMBERS C - DNA 001-93-C-0055 PE - 62715H PR - CD, CD, CD TA - CD, CC, CD WU - DH600200		
6. AUTHOR(S) Shel Schuster		8. PERFORMING ORGANIZATION REPORT NUMBER TRT 3336TR-1		
7. PERFORMING ORGANIZATION NAME(S) AND ADDRESS(ES) The Titan Corporation Titan Research & Technology Division 9410 Topanga Canyon Blvd, Suite 104 Chatsworth, CA 91311-5771		10. SPONSORING/MONITORING AGENCY REPORT NUMBER DNA-TR-93-187		
9. SPONSORING/MONITORING AGENCY NAME(S) AND ADDRESS(ES) Defense Nuclear Agency 6801 Telegraph Road Alexandria, VA 22310-3398 FCTT/Rinehart		11. SUPPLEMENTARY NOTES This work was sponsored by the Defense Nuclear Agency under RDT&E RMC Codes T4613D CD CD 60020 5900A 25904D, T4662D CD CC 60405 5720A 25904D and T4613D CD CD 60027 5900A 25904D.		
12a. DISTRIBUTION/AVAILABILITY STATEMENT Approved for public release; distribution is unlimited.		12b. DISTRIBUTION CODE		
13. ABSTRACT (Maximum 200 words) Finite difference for continuum mechanics codes are capable of providing solutions for the behavior of a wide range of materials under a variety of boundary and initial conditions. The key to obtaining accurate solutions lies in the fidelity of models used to describe the material's response to the strains imposed, i.e., its Equation of State (EOS). This report presents both the general EOS algorithms used in the CRALE 1- and 2D codes and several specific EOS models currently in use. A driver routine that exercises these models over specific load/unload paths is available to assist in developing and checking the parameters needed for materials of interest. A discussion of this driver and a users' manual to assist in its use are also presented. In the course of developing EOS models of interest to DNA and as part of the TRT participation in the DNA HYDROPLUS program, a number of data bases have been developed. These include files containing;				
14. SUBJECT TERMS CRALE HYDROPLUS		EOS USER'S MANUAL		15. NUMBER OF PAGES 102
		MATERIAL MODELING		16. PRICE CODE
17. SECURITY CLASSIFICATION OF REPORT UNCLASSIFIED	18. SECURITY CLASSIFICATION OF THIS PAGE UNCLASSIFIED	19. SECURITY CLASSIFICATION OF ABSTRACT UNCLASSIFIED	20. LIMITATION OF ABSTRACT SAR	

CLASSIFIED BY:

N/A since Unclassified.

DECLASSIFY ON:

N/A since Unclassified.

experimental shock Hugoniot and release paths, parameters for EOS models used in the HYDROPLUS program, and the nuclear shot experimental and calculational data bases developed for HYDROPLUS. A description of the various data bases with instructions for their access is included in this report.

Accession For		
NTIS	CRAM	<input checked="" type="checkbox"/>
DTIC	TAB	<input type="checkbox"/>
Unannounced		<input type="checkbox"/>
Justification		
By		
Date		
Appr		
A-1		

CONVERSION TABLE

Conversion factors for U.S. Customary to metric (SI) units of measurement

MULTIPLY $\xrightarrow{\hspace{2cm}}$ BY $\xrightarrow{\hspace{2cm}}$ TO GET
 TO GET $\xleftarrow{\hspace{2cm}}$ BY $\xleftarrow{\hspace{2cm}}$ DIVIDE

angstrom	1.000 000 X E -10	meters (m)
atmosphere (normal)	1.013 25 X E +2	kilo pascal (kPa)
bar	1.000 000 X E +2	kilo pascal (kPa)
barn	1.000 000 X E -28	meter ² (m ²)
british thermal unit (thermochemical)	1.054 350 X E +3	joule (J)
calorie (thermochemical)	4.184 000	joule (J)
cal (thermochemical)/cm ²	4.184 000 X E -2	mega joule/m ² (MJ/m ²)
curie	3.700 000 X E +1	*giga becquerel (GBq)
degree (angle)	1.745 329 X E -2	radian (rad)
degree Fahrenheit	$t_k = t_f + 459.67/1.8$	degree kelvin (k)
electron volt	1.602 19 X E -19	joule (J)
erg	1.000 000 X E -7	joule (J)
erg/second	1.000 000 X E -7	watt (W)
foot	3.0048 000 X E -1	meter (m)
foot-pound-force	1.355 818	joule (J)
gallon (U.S. liquid)	3.785 412 X E -3	meter ³ (m ³)
inch	2.540 000 X E -2	meter (m)
jerk	1.000 000 X E +9	joule (J)
joule/kilogram (J/kg) (radiation dose absorbed)	1.000 000	Gray (gy)
kilotons	4.183	terajoules
kip (1000 lbf)	4.448 222 X E +3	newton
kip/inch ² (ksi)	6.894 757 X E +3	kilo pascal (kPa)
ktap	1.000 000 X E +2	newton-second/m ² (N-s/m ²)
micron	1.000 000 X E -6	meter (m)
mil	2.540 000 X E -5	meter (m)
mile (international)	1.609 344 X E +3	meter (m)
ounce	2.834 952 X E -2	kilogram (kg)
pound-force (lbs avoirdupois)	4.448 222	newton (N)
pound-force inch	1.129 848 X E -1	newton-meter (N-m)
pound-force/inch	1.751 268 X E +2	newton-meter (N/m)
pound-force/foot ²	4.788 026 X E -2	kilo pascal (kPa)
pound-force/inch ² (psi)	6.894 747	kilo pascal (kPa)
pound-mass (1bm avoirdupois)	4.535 924 X E -1	kilogram (kg)
pound-mass-foot ² (moment of inertia)	4.214 011 X E -2	kilogram-meter ² (kg-m ²)
pound-mass/foot ³	1.601 846 X E +1	kilogram/meter ³ (kg-m ³)
rad (radiation dose absorbed)	1.000 000 x E -2	**Gray (Gy)
roentgen	2.579 760 X E -4	coulomb/kilogram (*C/Kg)
shake	1.000 000 X E -8	seconds (s)
slug	1.459 390 X E +1	kilogram (kg)
torr (mm Hg, 0°C)	1.333 22 X E -1	kilo pascal (kPa)

* The becquerel (Bq) is the SI of unit of radioactivity; 1 Bq = 1 event/s.

** The gray (GY) is the SI unit of absorbed radition.

TABLE OF CONTENTS

Section	Page
Conversion Table.....	iii
Figures.....	vi
Tables.....	vii
1 INTRODUCTION.....	1
1.1 Background.....	1
1.2 Report Structure.....	2
1.3 Symbols And Definitions.....	3
2 GENERAL EQUATION OF STATE ALGORITHMS.....	5
2.1 Pressure.....	5
2.2 Elastic Deviatoric Behavior.....	6
2.3 Plastic Yielding.....	6
2.4 Fracture.....	7
3 EOS MODELS.....	9
3.1 Subroutine Eqst: Overview And Generic Input.....	9
3.2 Specific Eos Models.....	13
3.2.1 The SHEL EOS.....	15
3.2.2 VIC.....	21
3.2.3 CIST.....	22
3.2.4 HE.....	24
3.2.5 MCST.....	28
3.2.6 SCUB.....	28
3.2.7 H ₂ O.....	28
3.2.8 UEOS.....	28
3.2.9 CAP.....	29
3.2.10 MIX.....	30
3.2.11 Others.....	30

TABLE OF CONTENTS (Continued)

Section	Page
4	EQS – THE EQUATION OF STATE DRIVER..... 31
4.1	Overview..... 31
4.2	Code Modules..... 32
4.2.1	EQS, the Main Program..... 32
4.2.2	EQN..... 37
4.2.3	EXPHUG..... 39
4.2.4	FLIP - Reverse Hugoniot..... 42
4.2.5	HUG - The Hugoniot Driver..... 44
4.2.6	REL – Release Adiabats from the Hugoniot..... 48
4.2.7	PATH - Special Paths..... 52
4.2.8	PLOTN-Plotting Options..... 53
5	DATA BASES 59
5.1	Hugoniot..... 59
5.1.1	Experimental Data (ROCKHUG and METHUG)..... 59
5.1.2	Shock Velocity, U_s , vs Particle Velocity, U_p , Fits (USUP.dat, 1-1-94)..... 61
5.2	Release Adiabats (Relad.dat, 1-1-94)..... 66
5.3	Material Models (Eoss.dat) 1-1-94..... 68
5.4	Hydroplus Archival Databases..... 69
5.4.1	Introduction..... 69
5.4.2	Equation of State/Numerical Results..... 69
5.4.3	Nuclear Shot Data..... 71
 Appendix	
A	LIST OF FILES IN UNCLASSIFIED DIRECTORY..... A-1
B	EXAMPLE OF THE HYDROPLUS NUCLEAR SHOT DATA BASE B-1

FIGURES

Figure		Page
3-1	Release Path From the CJ Point of TNT Showing the Contributions of the Three in the JWL EOS	26
4-1	Flowchart of EQS, the Equation of State Driver Routine	33
4-2	Example of Plot Generated by ROUT=PLOT with NP[1]=2 or 3	56
4-3	Example of Plot Generated by ROUT=PLOT with NP[1]--5	57
4-4	Example of Plot Generated by ROUT=PLOT with NP[1]--6 ...	58

TABLES

Table		Page
1-1	Glossary of general EOS terms and symbols.....	3
3-1	Summary of input for the EOS models.	10
3-2	EOS input variables.....	11
3-3	General parameters used by all equations-of-state.....	12
3-4	Summary of CK block parameters of current EOS models.	14
3-5	Equation-of-state parameters for SHEL (EOS 1).....	20
3-6	Equation-of-state parameters for VIC (EOS 2).	21
3-7	Equation-of-state parameters for CIST (EOS 3).....	23
3-8	JWL parameters for some common high explosives.....	27
3-9	Equation-of-state parameters for HE (EOS 4).....	27
3-10	Equation-of-state parameters for CAP (EOS 9).....	29
3-11	Equation-of-state parameters for MIX (EOS 10).....	30
4-1	Summary of the input to EQS.....	34
4-2	Parameters on line 4 of EQS input.	36
4-3	Example of the output generated by ROUT = EQN.....	41
4-4	Example of FLIP printout for Borehole Correction Factors.....	43
5-1	Shock relationships.....	60
5-2	Materials stored in the ROCKHUG.dat file (Unit 10) 11-11-93.	62
5-3	Materials stored in the METHUG.dat file (Unit 11) 11-11-93.....	63
5-4	Example of experimental Hugoniot data stored on the ROCKHUG.dat and METHUG.dat files.	64
5-5	Material Us-Up Relations Available on USUP.dat File	65

TABLES (Continued)

Table		Page
5-6	Example of Data on RELAD.dat (1-1-94)	66
5-7	List of 105 Sets of Release Adiabats on RELAD.dat (1-1-94).....	67
5-8	Listing of the EOS Models in the EOSS.dat Data File, Tape 14 as of 10/27/93.....	68
5-9	Materials in HYDROPLUS EOS Database	70

SECTION 1

INTRODUCTION

1.1 BACKGROUND.

For any finite difference continuum mechanics code, it is necessary on every cycle to compute the complete state of stress in each cell in order to generate the forces needed to advance the solution. The set of algorithms used to calculate these stresses may range from the simplest perfect-gas law, in which the mean stress (i.e., pressure, P) is expressed as a function of only two independent variables, the density (ρ) and specific energy (E), to one that computes the complete nine-component stress tensor (σ_{ij}) as a function of the energy, the current strain tensor (ϵ_{ij}), and the path taken from the material's initial state to its present one. More complex models may even combine several material components and/or phases (e.g., soil and air or water), use non-isotropic stress-strain relations, or incorporate time-dependent rate effects, as needed by the specific problem at hand.

Titan Research and Technology's (TRT)¹ CRALE 1- and 2-D finite difference codes assume the stress tensor is separable into the mean stress, P , and a deviatoric stress tensor, σ'_{ij} . The algorithms used to obtain the mean stress are collected in subroutines commonly referred to as the Equation of State (EOS). The separation of P and σ'_{ij} allows the code to bypass calculations of stresses and strains for those materials that can only support a pressure, e.g., gases and fluids such as air, water or high explosive (HE), or a solid which has melted. Such materials only require the current density and energy to obtain the pressure. For more complex material behavior, the code assumes that the stress deviators can be calculated from the previous stresses and current increments of the strain tensor, $\Delta\epsilon_{ij}$ and that, at most, only four² deviatoric stresses are required. i.e., σ'_{xx} , σ'_{yy} , σ'_{zz} , σ'_{xy} . Finally, provisions are included to account for hysteresis, fracture, and other nonelastic responses such as solid-solid phase changes, plastic flow and dilation.

The most general constitutive relations in CRALE model the behavior of an isotropic, elastic-plastic, hysteretic material which can crack under tensile loads. For simpler, purely hydrodynamic models, e.g., HE and WATER, no deviatoric stresses are

¹ A division of Titan Corp, formerly California Research and Technology, CRT

² The missing stress components are either zero due to the 2D symmetry or equal to σ'_{xy} due to equilibrium requirements.

present and the material pressure state is completely specified by casting the pressure as a function of the current density (ρ, RHO^3) and specific energy (E, ENG). [Rather than density, CRALE passes the excess compression, $\mu (= [\rho/\rho_0]-1, EMUL)$ to minimize roundoff error.]

Since a wide range of materials and loading conditions may exist in any specific calculation, a number of different EOS routines are available. CRALE1 and 2 have been written so that general routines (SHEL, MIX, VIC, CIST, MCIST, HE, WATER, and CAP) are available to model a wide variety of materials. In addition, the EOS calculation is linked to the main codes by passing variables through named common blocks, /EOS/, /EOS2/ and /EOS3/, so that the user may include his own routine using a shell routine, UEOS, with a minimum of effort. (Additional EOS models have been incorporated on various program libraries, PL's, from time to time, e.g. AFWL, S3EOS, WAGNER and GRAY. These routines have been removed for the current codes as obsolete, but could easily be reactivated if required.)

1.2 REPORT STRUCTURE.

This report is intended to provide a description of the routines used by the CRALE codes to obtain the stress state in a cell. A glossary of terms used in the codes follows in Section 1.3. A general overview of the material modeling algorithms used in CRALE is presented in Section 2. A summary of the general input required by the EOS models and the various EOS models currently available in CRALE are described in Section 3.

As part of the procedures used during development of the material models, a program, EQS, was written that allows the user to drive any EOS module through a variety of stress-strain paths and compare the results with experimental data. A User's guide for EQS, with detailed descriptions of the I/O options, is presented in Section 4.

Various data bases have been constructed and maintained for DNA by TRT for use in constructing and verifying the EOS models and to provide archival storage for data. These data bases are discussed in Section 5. Instructions to allow the DNA user community access to these files is also included.

³ The code names for the various quantities are shown in red and *Italic*..

1.3 SYMBOLS AND DEFINITIONS.

The fundamental units in the CRALE codes and the EOS routines are gram-centimeter-microsecond (g-cm- μ s). Hence, the units of pressure (stress) and energy are Megabars (Mb) and Terraergs (Te), respectively. A glossary of terms used in this report is presented in Table 1-1. Model specific variables are defined in Section 3.

Table 1-1. Glossary of general EOS terms and symbols.

Variable	Units	Code Symbol	Definition
B, K	Mb		Bulk moduli, $dP/d\mu$
B_0	Mb	BO	Initial Bulk moduli
B_m	Mb	BM	Maximum Bulk moduli
C_L	cm/ μ s		Longitudinal sound speed, $C_L^2 = (K + 4/3G)/\rho_0$
C_p	cm/ μ s		Bulk sound speed, $C_D^2 = K/\rho_0$
C_s	cm/ μ s		Shear wave speed, $C_S^2 = G/\rho_0$
E	Te/g	ENG	Specific internal energy of the material
E_m, E_s	Te/g	EM, ES	Specific internal energy of vaporization of the material
G	Mb	G	Shear modulus
ϵ			The strain tensor; i.e., ϵ_{ij} , $i, j=1, 3$.
ϵ'			The deviatoric strain tensor; i.e., ϵ'_{ij} , $i, j=1, 3$.
I_1			1st invariant of the strain tensor; $= \sum \epsilon_{ij}$, $i=1, 3$
I_2			2nd invariant of the strain tensor; $= 1/2 \sum \epsilon_{ij} \epsilon_{ij}$, $i, j=1, 3$
I_3			3rd invariant of the strain tensor; $= \epsilon_{ij} $, $i, j=1, 3$
J	Mb		The stress tensor; i.e., σ_{ij} , $i, j=1, 3$.
J'	Mb		The deviatoric stress tensor; i.e., σ'_{ij} , $i, j=1, 3$.
J_1	Mb		1st invariant of the stress tensor; $= 3P = \sum \sigma_{ij}$, $i=1, 3$
J_2	Mb ²		2nd invariant of the stress tensor; $= 1/2 \sum \sigma_{ij} \sigma_{ij}$, $i, j=1, 3$
J_2'	Mb ²	J2P	2nd invariant of the deviatoric stress tensor; $= 1/2 \sum \sigma'_{ij} \sigma'_{ij}$, $i, j=1, 3$
J_3	Mb ³		3rd invariant of the stress tensor; $= \sigma_{ij} $, $i, j=1, 3$
P	Mb	P	Pressure or mean stress, $= J_1/3$
Y	Mb		Plastic yield surface, $=$ the maximum elastic $(J_2')^{1/2}$
Y_0	Mb	YO	Cohesion, the yield surface at $P=0$
Y_{vm}	Mb	YVM	Maximum Y; named for Von Mises
β	Te/g	$\dot{C}TE$	Coefficient of thermal expansion
Γ			$\gamma-1$ in perfect gas EOS
η		ETA	Compression; $= \rho/\rho_0$
μ		EMU	Excess compression; $= \eta-1 = \rho/\rho_0-1$
ϵ			Strain
ϵ_{ij}			The ij component of the strain tensor
ϵ'_{ij}			The ij component of the deviatoric strain tensor; $= \epsilon_{ij} - I_1 \delta_{ij}/3$
ν			Poissons Ratio
ρ	g/cm ³		Density of the material
ρ_0	g/cm ³	RHOZ	Initial density of the material
ρ_r	g/cm ³	RHOREF	Reference density of the material
σ	Mb		Stress
σ_{ij}	Mb		The ij component of the stress tensor
σ'_{ij}	Mb		The ij component of the deviatoric stress tensor; $= \sigma_{ij} - P\delta_{ij}$

During the course of writing this report, it became obvious that a number of terms in common usage appear to be somewhat loosely defined. For the purposes of this report the following conventions are assumed.

- Stresses and strains are considered positive in compression. Note, this convention is consistent with P and μ , but generally the opposite of standard engineering usage.
- The term "Equation-of-State, EOS" is used in the narrow sense of relating the mean stress (pressure) to the density and energy. "Constitutive model" refers to the complete stress-strain relation. Unfortunately, the terms are frequently used interchangeably. EOS was commonly used by physicists to describe high temperature, high pressure states; engineers interested in the low stress behavior of materials tended to talk of constitutive behavior. Since calculations in the codes frequently require models that represent a continuum of behavior spanning pressures ranging from tensions to multi-Megabars, the distinctions between Equations of State and constitutive models have become blurred.
- Similarly, the terms, elastic, non-elastic and plastic need to be defined. We use elastic to describe incremental changes in deviators that obey Hook's law, i.e., $\delta\sigma = M\delta\varepsilon$, where the modulus, M , is only linear in the increment. Any other changes to the stress tensor are non-elastic, e.g., fracture, hysteresis or phase changes. Plasticity describes only those non-elastic changes that result when deviatoric stresses try to exceed the strength of the material.
- Strains are incrementally computed from displacement and are the natural strains ($\Delta v/v$), not small strain or engineering strain. Small strain ignores the cross-products in computing the volumetric strain; engineering strain relates changes in displacement to the initial rather than current positions. Differences between these definitions become significant at strains of about 5%. Transformations between the strain definitions are possible. It should be noted that, due to non-elastic effects, the differences between the various strains do not translate into similar changes in stress. In fact, small-strain codes have frequently generated accurate solutions even when material underwent extreme distortion.
- The terms 'pressure' and 'mean stress' are used interchangeably.

SECTION 2

GENERAL EQUATION OF STATE ALGORITHMS

CRALE, typical of finite difference, continuum mechanics codes, requires values of the complete constitutive behavior of the material in each computational cell for each cycle in order to derive a solution. The EOS models which relate the thermodynamic variables, i.e., stress and energy, to the mechanical variables, position and density and to the past history of the material provide one part of the behavior, additional algorithms are needed to complete the description.

In general, the calculation of the constitutive behavior for each cell in a CRALE solution proceeds in 5 steps, namely;

1. update the cell coordinates based on previous positions and velocities,
2. calculate the density, ρ , and specific energy, E ,
3. call the appropriate EOS module to obtain the new mean stress and elastic moduli, K and G
4. if necessary, compute incremental changes in the strain tensor, $\Delta\epsilon'_{ij}$, and calculate an intermediate stress tensor assuming the changes are elastic,
5. test and adjust the stress tensor, as needed, based on plastic yielding, tensile failure.

A more complete description of the general methodology of steps 3 through 5 follows. Model specific differences from these algorithms are presented in the discussions of the various EOS models in Section 3.

2.1 PRESSURE.

In general, CRALE assumes that the mean and deviatoric components of stress are separable. Furthermore, the mean stress is composed of two parts; a solid and a vapor component. Both components are functions of ρ and E , but the solid portion is primarily a function of density while the vapor pressure is governed by the energy per unit volume (ρE). The CRALE code provides the various EOS models with the current density, internal energy and a history parameter and expects the pressure, sound speed, bulk modulus and shear modulus in return. Any coupling of the pressure to the deviatoric stresses is included in the history parameter. Currently, the maximum excess compression, μ_{max} , which the material has experienced is used as the history parameter primarily to determine the effect of hysteretic compaction on the pressure

and moduli. To minimize potential round-off errors, μ , the excess compression is carried by the codes, rather than ρ .

2.2 ELASTIC DEVIATORIC BEHAVIOR.

For materials that support deviatoric stresses, the EOS module returns a non-zero shear modulus to the main code. The code then calculates the change in the strain tensor and computes the incremental elastic change in the deviatoric stresses by the simple Hook's law Equation;

$$\Delta\sigma'_{ij} = -2G\Delta\epsilon'_{ij} \quad (2.1)$$

The negative sign is required because, in CRALE, strains are defined as positive in tension while stresses are positive in compression. The shear modulus is calculated in the EOS each cycle and may vary with compression or pressure so that the stresses, in general, are only incrementally, linearly elastic.

2.3 PLASTIC YIELDING.

The CRALE codes assume that the deviatoric stresses a solid material is capable of supporting are limited by a surface in stress space which is a function of the mean stress and the sign of the third invariant of the deviatoric stress tensor, J_3 although more sophisticated surfaces such as that incorporated in the CAP⁴ model are also possible. The surface currently used in the codes is defined by relating the maximum allowable second invariant of the deviatoric stress tensor, J_2 , and the pressure, thus;

$$\sqrt{J_2} < F(P) = F(J_1 / 3) \quad (2.2)$$

$$F(P) = \begin{matrix} Y_{vm} - (Y_{vm} - Y_o)e^{-(P/P_y)} \\ \text{or} \\ \max [Y_{vm}, Y_o + Y_1P] \end{matrix} \quad (2.3)$$

where Y_{vm} , Y_o and P_1 are input parameters which may depend on J_3 and whether the material is intact or fractured.

⁴ G.Y. Baladi, "An Effective Stress Model for Ground Motion Calculations", WES TR SL-79-7, Sept 1979

In CRALE2, the calculations of the deviatoric stress tensor are performed in subroutine STRAIN, so the EOS subroutines only set the elastic moduli and elastic yield surface parameters for the current material. The yield parameters are stored in CK(28,NE) through CK(37,NE) for all the EOS models and are illustrated in the sketch below. As shown in the figure, the yield surface is generally of the Drucker-Prager form with a von Mises limit, although strain hardening or softening of the initial yield surface may be included by setting the hardening and softening parameters (*BETAH* and *BETAS*) and the value of plastic strain (*EPYLD*) at which the material stops hardening and begins to soften. The yield surface can never harden above *YLDVM* or soften below the surface for 3-cracked material.

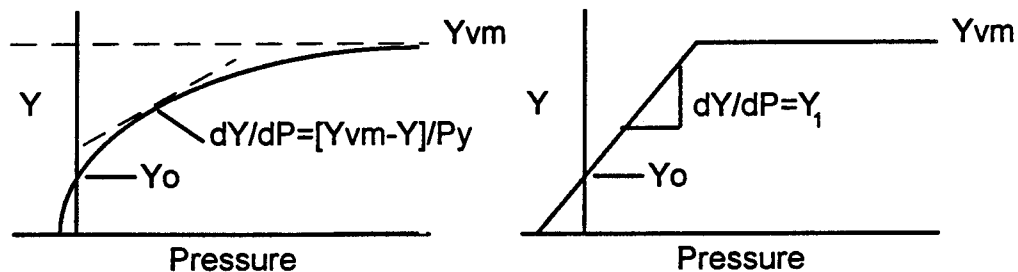

If $\sqrt{J_2}$ exceeds the yield surface the code imposes a flow rule that adjusts the deviators so that $\sqrt{J_2}$ equals Y . Two basic options exist; associated and non-associated flow. The non-associated flow simply reduces the stress deviators proportionally without changing the mean stress, i.e., along a path perpendicular to the pressure axis in the sketch and is the default condition. Associated flow (activated by setting *YFLOWR*=1) moves $\sqrt{J_2}$ along a line perpendicular to the yield surface itself. This adjustment produces a change in the mean stress along with the change to the deviators and can generate nonphysical states.

2.4 FRACTURE.

The CRALE code allows material to crack under several conditions. After completing the calculation of the pressure and stress deviators assuming the material is intact, the stress tensor is rotated to obtain the three principal stresses, $\sigma_{ii}, i=1,3$. The code allows cracks to open in several possible ways, i.e., as a single crack, as two orthogonal in-plane cracks, as a combination of an in-plane and a hoop crack or in all directions.

To determine if a previously intact cell is cracked, each σ_i is compared to the tensile limit, σ_t . If any one principal stress is less than σ_t ($\sigma_t < 0$), a crack is opened.

The offending stress is set to zero and the other two stresses are adjusted assuming the change is due to a change in the strain perpendicular to the σ_i direction. The principal angle, Θ_i , is saved and the remaining two stresses rechecked to insure that they are still greater than σ_i . The amount of strain required to return the stress to zero is also stored as a crack volume (*VCR1*). If the stress adjustment has driven a second principal stress beyond σ_i , the code also sets it to zero and resets the third stress, again assuming a uniaxial strain change, and saving the adjustment as a second crack volume (*VCR2*). On subsequent cycles, the material volume is reduced by the sum of *VCR1* and *VCR2* when computing the pressure.

After a cell has cracked, the code rotates the stresses using Θ_i as one reference angle; no shear stress is allowed parallel to this direction. Once one or two cracks have opened, the stress perpendicular to the crack is continually returned to zero and the crack volume adjusted. Upon recompression, the stress is not permitted to go positive until the crack volume has been reduced to zero.

If all three principal stresses exceed the tensile limit, the material is assumed to have shattered. In this case, all the stresses and the crack volumes are set to zero, hence the material can only support positive stresses upon recompression if the pressure is positive.

Because of its unique treatment of stress, the fracture logic is bypassed for material using the CAP model EOS.

SECTION 3

EOS MODELS

3.1 SUBROUTINE EQST: OVERVIEW AND GENERIC INPUT.

In order to permit some flexibility in using multiple material models in a single calculation, all of the EOS routines are accessed by CRALE1, CRALE2 and their ancillary programs via calls to one main subroutine, EQST. Hence adding new models or changing the EOS I/O only requires updating EQST. The material properties for the models needed are initialized by a call to ESINIT, an entry point in EQST. After all the model data have been read in, the parameters are echoed to the output file by ESPRNT, a second entry point in EQST.

The parameters of the various EOSs are obtained by the code in several ways. In general, the code initializes the EOS parameters via a CALL to ESINIT, an entry point in subroutine EQST. ESINIT reads an initial line with the name of the material, three flags and a 48-character comment. The first flag, *NETYPE*, designates which EOS model to use; the second, *NEO*, if the input data is to be read from the data base on Tape 14; and the third, *ICNES*, the units of the EOS input parameters for this material. If the material is not available from the data base, i.e., *NEO*=0, the code proceeds to read a second line with the initial (*RHOZ*) and reference (*ρ*) densities, the minimum vaporization energy density (*EM*), the initial energy density (*EZ*), and the tensile limit (*ST*). Knowing which EOS to use, the code now reads the necessary additional parameters into the CK block. The number of lines of input parameters varies with each EOS, the more complicated models requiring more data. Currently, subroutines SHEL, MIX, CIST, and CAP read 40 input parameters (i.e. 5 data line with 8 numbers per line); HE only reads two additional lines, 16 variables. The parameters required by each EOS are discussed in Section 4. As shown schematically in Table 3-1 and defined in Table 3-2, data sets for up to 15 different materials can be read, in arbitrary order, for any single code run. The input file for phyllite (as echoed by ESPRNT) is included in Table 3-1 as an example for a material using the SHEL EOS model. Similar input files can be recalled from the EOSS.dat file; a list of which is provided in Table 5-8. This data base can be accessed by the codes for ease of inputting specific materials and to insure uniformity throughout the various programs.

All the EOS used by the CRALE codes and their auxiliary routines use the named COMMON blocks, /EOS1/, /EOS2/ and /EOSY/ to store and transfer the values of the parameters and the input/output quantities required for each call to the EOS. Table 3-3 lists each of these variables with its size, units, and definition. An I or O in the column labeled I/O signifies this variable is either passed into (I) or calculated and returned from (O) the EOS every call. The other quantities in the COMMON blocks remain constant for each material or for the entire problem (e.g., ATMOS).

Table 3-1. Summary of input for the EOS models.

LINE	VARIABLES / FORMATS							
1	IEOS A6	NETYPE I2	NEO I2	ICNES I2	TMATRIX A6	TSOLID A6	TFLUID A6	WORDS 12A4
1a	CONV 8F10.0	(if needed)						
1b	UNITS 8A8	(if needed)						
2	RHOZ F10.0	RHOREF F10.0	ES F10.0	EZ F10.0	ST F10.0			
3	CK 1-N 8F10.0	N =40 for SHEL, CIST, MIX, CAP =16 for HE						
4	END							

```

LINE 1  PHYLL 1  an example of the input for the SHEL EOS
LINE 2  2.7800E+00 2.7800E+00 7.0000E-02 0.0000E+00 6.6700E-05
LINE 3a  4.0000E-01 8.0000E-01 2.0000E-01 0.0000E+00 0.0000E+00 0.0000E+00 0.0000E+00 0.0000E+00
LINE 3b  0.0000E+00 0.0000E+00 0.0000E+00 0.0000E+00 0.0000E+00 0.0000E+00 7.5000E-02 0.0000E+00
LINE 3c  3.0000E+00 0.0000E+00 0.0000E+00 4.2500E+00 2.0000E-02 1.3000E-01 3.5000E+00 2.0000E+00
LINE 3d  3.0000E-01 0.0000E+00 0.0000E+00 0.0000E+00 0.0000E+00 0.0000E+00 0.0000E+00 0.0000E+00
LINE 3e  8.0000E-03 5.0000E-04 2.5000E+02 0.0000E+00 0.0000E+00 0.0000E+00 0.0000E+00 0.0000E+00

```

Table 3-2. EOS input variables.

VARIABLE DEFINITIONS

<u>LINE = 1</u>	<u>FORMAT = A6, I2,2x,I2,3A6,12A4</u>	
IEOS	Name of the Equation-of-State (EOS)	
NETYPE	Number of the EOS Subroutine	
	1 - SHEL (CRT)	
	2 - VIC (CRT)	
	3 - CIST (Modified AFWL EOS)	
	4 - HE (LLL Hi Explosive)	
	5 - MCST (CRT)	
	6 - SCUB (Obs SCUBED Table Lookup)	
	7 - H2O Walker-Sternberg Water	
	8 - WAGN (Obs CRT model)	
	9 - CAP (WES form of the CAP EOS)	
	10- MIX (CRT)	
NEO	if > 0 Read EOS input for this material from Tape 14	
ICNES	if = 0 EOS data in standard code units	
	= 1 - 8 use ICNES set of units from table for this EOS input	
	= 9 -10 read in (lines 1a & 1b) and use special set of units for this input	
TMATRX	the matrix EOS used if INEOS=10	
TSOLID	the solid EOS used if INEOS=10	
TFLUID	the fluid EOS used if INEOS=10	
WORDS	Comment	
<u>LINE = 1a</u>	<u>FORMAT = 8F10.0</u>	Optional: read only if ICNES > 8
CONV	New set of conversion factors for EOS	
<u>LINE = 1b</u>	<u>FORMAT = 8A8</u>	Optional: read only if ICNES > 8
UNITS	Names of new units	
<u>LINE = 2</u>	<u>FORMAT = 8F10.0</u>	
RHOZ	Initial density (ρ_0) of material	
RHOREF	Reference density (ρ_{ref}) of material	
ES	Max energy of solid material	
EZ	Initial energy of zones	
ST	Tensile limit, ≤ 0	
<u>LINES = 3</u>	<u>FORMAT = 8F10.0</u>	
CK 1-N	Parameters of the EOS. N varies according to the type of EOS.	
	See Sec 4 for details of EOS input.	
<u>LINE = 4</u>	<u>FORMAT = A6</u>	
END	EOS data terminated by line with IEOS = 3hEND	

Table 3-3. General parameters used by all Equations-of-state.

<u>VARIABLE</u>	<u>UNITS</u>	<u>DESCRIPTION</u>
ATMOS	Mbar	Atmospheric pressure, generally set to 1 bar
BETAH	Mbar	Strain hardening parameter
BETAS	Mbar	Strain softening parameter
CK		Parameters used by the EOSs
COHC	Mbar	material cohesion in compression
COHE	Mbar	material cohesion in extension
COHES		
COHF	Mbar	cohesion of 3-cracked material
CSS	cm/s ²	Sound speed of cell
DETA	--	The change in EMUL on this cycle
DMUU	--	Maximum μ of cell (μ_{max})
DPDE	Mb-g/Te	Derivative of P with energy
DPDMU	Mbar	Derivative of P with compression
DYDPC	DY/DP	of material in compression
DYDPE	DY/DP	of material in extension
DYDPF	DY/DP	of 3-cracked material
EFRAC	Te/g	$E - E_m)/E_m$
EM	Te/g	Set to ES(NE)
EMUL	--	Excess compression of cell
ENG	Te/g	Specific internal energy of the cell
EPSKK		
EQUATIOND		
UM		
EPYLD	--	Plastic strain where Y switches from strain hardening to softening
ES	Te/g	Vaporization energies of each EOS
EZ	Te/g	Initial energy densities of each EOS
G	Mbar	Shear modulus
GEOP	Mbar	Geostatic pressure in cell
ICNES		Allows input in units other than standard
ICR	--	Crack state
IEOS	--	
IEOSPR	--	Debug sentinel (with *DEFINE DEBUG)
NE	--	Number of the EOS for this material
P	Mbar	Pressure
PAIR	Mbar	The air pore pressure
PM	Mbar	Pressure on last cycle
PYLD	Mbar	Obsolete
RHOREF	g/cm ³	Reference densities for each EOS
RHOZ	g/cm ³	Initial densities for each EOS
ST	Mbar	Tensile strengths for each EOS
STRSS	--	
VZ	cm ³ /g	Reference specific vol of each EOS
YFLOWR		Flow rule sent (0=non-assoc,1=assoc)
YLDMXC	Mbar	Maximum Y in compression
YLDMXE	Mbar	Maximum Y in extension
YLDMXF	Mbar	Maximum Y for 3-cracked material

3.2. SPECIFIC EOS MODELS.

The various subroutines described in this section generally calculate the mean stress or pressure (P), bulk and shear moduli (K,G) and longitudinal sound speed (CSS) for any pair of input values of density (ρ), specific energy (E) and, for hysteretic materials, the maximum compression (μ_{max}). Elastic moduli are only required for materials that support deviatoric stresses and can be set to zero for gases or fluids. (If G is set to zero the code will suppress the calculation of deviatoric stresses and strains.

The parameters used by the various EOS subroutines are stored, by material, in the two-dimensional array CK(i,NE), summarized in Table 3-4, and defined in the tables accompanying the description of each model that follows. For each of the CK variables available to the specific EOSs, the mnemonic equivalent is given, followed by a Y (yes) in the INPUT column, if this CK is an input number. If the CK is modified by the subroutine after input and replaced by a new value stored in the same location, a Y appears in the MOD (modified) column; a C in this column indicates the value is derived from other input. The internal code units of the parameter are given next, followed by a short description. Parameters calculated for information only (FIO) are so labeled. These may include data which are no longer used by the code (such as *PYLD*) and derived numbers which may be useful (e.g., initial wave speed and porosity). Only the first 50 CK variables are echoed to the output file.

The SHEL EOS model was originally developed in the late 1960's when the scope of many finite difference code solutions was expanded to include pressures and stresses that extended from tenths of a bar to many Megabars with particular emphasis on ground media, i.e., soils and rocks. A continuous EOS model capable of including elastic and non-elastic behavior as well as the high temperature pressure-volume-energy relations was needed. Over the years, the SHEL model has evolved to include several hysteretic options, solid-solid phases and other changes needed to describe specific material behavior. Several of the other models, i.e., VIC, MCST, MIX use or are derivatives of the SHEL EOS. Hence, the SHEL EOS routine is discussed in detail in Section 3.2.1; the other model descriptions reference it as appropriate.

Table 3-4. Summary of CK block parameters of current EOS models.

EOS # NAME CK's	1 SHEL	2 VIC	3 CIST	4 HE	5 MCST	8 UEOS	9 CAP	10 MIX
1	BO	CUR	C1	HEGAM	A	user	AKEI	
2	BM	C1	C2	A	B	specified	AK1	C
3	XMUO		C3	R1	EO	model	AK2	B
4	PTOE	P1	P1	B	ESS		AK3	GAMZ
5	A1		P2	R2	ESP		AK4	AGAM
6	BTOE	P3	P3	DETV	ALPHA		AK5	GAMMZ
7	AMU1	XMU	EPOT	AGAMM	BSQ		AK6	
8	A2	ALFA		CJP	AA		AK7	GAME
9	DMUMN	EMU3	EMU3	AGAM	BB		AKIM	GP
10	DMUMX	ALPH1	EMU2	GAMPG	GM		AK1M	TMZ
11		EMU1	EMU1		POIS		AK2M	VJ
12		EMUMX	EMUMAX		GOK		AA	VB
13		B1ELAS			DELZ		AB	AYP
14		BUR	B1				AB1	DELSP
15	STOV	DPDMU1	B2				AC	THETA
16	SWTH	DPDMUK	B3					ALFAP
17	CTE	CTE	CTE	A1	AP		AGEI	RP3
18	ENGPH	PMU2	EV	A2	BP		AG1	PCC
19	PH1	FPRL	FPRL	CUTA	EPM		AG2	EZZ
20	ZMU2	FPRU	FPRU	B1	EPP		AG3	DSA
21	PHRE1	ALLPHA		B2	DEP		AG4	SMA
22	PHRE2	PMU1		CUTB			CRO	ZJ
23	BM2	PMU2		CUTC			CR1	XJ
24	PHC	BETA					CR2	RP3SQ
25	POIS		PRL				AW	
26	FPOIS		PRU				AD	
27	GMAX	GMAX	GMAX				AD1	
28	BETAH	BETAH	BETAH		BETAH		AD2	BETAH
29	BETAS	BETAS	BETAS		BETAS		AD3	BETAS
30	EPYLD	EPYLD	EPYLD		EPYLD		AD4	EPYLD
31	YFLOWR	YFLOWR	YFLOWR	CJMU	YFLOWR			YFLOWR
32	YLDMXF	YLDMXF	YLDMXF	CJGAM	YLDMXF			YLDMXF
33	YLDMXC	YLDMXC	YLDMXC		YLDMXC		SJMX	YLDMXC
34	COHC	COHC	COHC		COHC		CKMX	COHC
35	DYDPC	DYDPC	DYDPC		DYDPC		CKAA	DYDPC
36	YLDMXE	YLDMXE	YLDMXE		YLDMXE		LTYPE	YLDMXE
37	COHE	COHE	COHE		COHE			COHE
38	DYDPE	DYDPE	DYDPE		DYDPE			DYDPE
39	COHF	COHF	COHF		COHF			COHF
40	DYDPF	DYDPF	DYDPF		DYDPF			DYDPF
41	EMUZ						ASTART	
42	ETAZ						XSTART	
43	EMU1						FCUT	
44							TCUT	
45								
46								
47								
48								
49	VREF	VREF	VREF	VREF	VREF	VREF	VREF	VREF
50	NEOS	NEOS	NEOS	NEOS	NEOS	NEOS	NEOS	NEOS

3.2.1 The SHEL EOS.

3.2.1.1 General.

Given: a state of the material defined by its current ρ , ϵ_{ij} ; E and some measure of the past strain path

Find: the pressure or mean stress, P and the deviatoric stress tensor, σ'_{ij}

Definitions for the parameters used in SHEL are presented in Table 3-5.

The SHEL EOS proceeds as follows. Assume the pressure is composed of two terms, a solid part, P_s , which depends on compression, energy and a past history parameter and a vapor part, P_v , which is a function of ρ and E . Then;

$$P(\rho, E) = P_s(\rho, E) + P_v(\rho, E) \quad (3.1)$$

$$P_s = B_m \mu' - (B_m - B_o) \mu^* (1 - e^{-\mu'/\mu^*}) \quad (3.2)$$

$$P_v = \Gamma \rho E^* ; \quad (E > E_m) \quad (3.3)$$

where

$$\mu' = \mu + \beta E \quad (3.4)$$

$$E^* = (E - E_m)(1 - e^{-[E - E_m]/E_m}) \quad (3.5)$$

$$\Gamma = \gamma - 1 = 0.6 + 0.023[\ln(\rho/E)]^2 + 0.14 \cdot \ln(\rho/E) + 0.05 \cdot \ln \rho \quad (3.6)$$

Five parameters are required to compute the pressure (Equation 3.1) in a material with no air-porosity (voids), i.e. $\rho_o = \rho_r$, in addition to the reference/initial density.

They are:

E_m = minimum energy required to activate P_v , (Te/g)

B_o = the zero pressure bulk modulus, $dP/d\mu$ (Mb)

B_m = the maximum bulk modulus, (Mb)

μ^* = the excess compression at which the bulk modulus has increased exponentially to $\sim [2/3 B_m + 1/3 B_o]$

β = coefficient of thermal expansion, (g/Terg); NOTE: βE is equivalent to the Gruneisen energy dependence of the solid pressure, i.e., $\Gamma \rho E$.

3.2.1.2 Hysteresis Due To Air-Filled Porosity. For a material which contains air-filled porosity, i.e., less than 100% saturation, the pores may collapse irreversibly under compression so that the behavior of the material is path dependent. Several additional steps and a new independent variable are required to compute the pressure. In the SHEL routine, the new variable, μ_{\max} (μ_m), is the maximum excess compression ever attained by the material. For a material containing air-filled void spaces, the initial density, ρ_0 , is always less than the reference density, i.e.; $\rho_0 < \rho_r$. By convention, the excess compression, μ , relative to ρ_0 is passed to the SHEL routine. Since the SHEL EOS algorithms are based on the reference density, ρ_r , the routine transforms the μ 's to correspond to ρ_r .

A fundamental assumption governs the pressure behavior of the porous material under loading, namely, there is a transformation in μ to an equivalent value along the load path of the solid (void-free) material. To calculate the pressure, we first find the solid μ equivalent to μ_m and then obtain a modified μ' for the current compressional state of the material to use in Equation 3.2 as follows.

Define:

$$\eta_z = \rho_0 / \rho_r, \quad \mu_z = \eta_z - 1 \leq 0, \quad \epsilon_z = -\mu_z / \eta_z \quad (3.7)$$

Any excess compression, μ relative to ρ_0 , can be transformed into an equivalent μ_r relative to ρ_r , by

$$\mu_r = \eta_z \mu + \mu_z \quad (3.8)$$

As for a nonporous solid (Equation 3.4), we again augment μ and μ_m by adding the thermal contribution to both;

$$\left. \begin{aligned} \mu'' &= \mu + \beta E \\ \mu_m'' &= \mu_m + \beta E \end{aligned} \right\} \quad (3.9)$$

An offset parameter, Δ , is computed next to transform the compression into the frame of the reference density;

$$\Delta = \mu_z (1 - e^{\alpha_2 \mu_m'' / \epsilon_z}) + \mu_1 (1 - e^{-\alpha_1 \mu_m'' / \mu_1}) e^{\alpha_2 \mu_m'' / \epsilon_z} \quad (3.10)$$

where α_1 , α_2 and μ_1 are additional input parameters. The first term on the right-hand side of Equation 3.10 provides a smooth convex curve starting at $p = p_0$ which

asymptotically approaches the reference P- μ hydrostat; the second term adds a toe to the initial loading. Physically, the first term represents the irreversible pore collapse and the breakdown of cementation bonds in the matrix, while the second term is a measure of the initial elastic response of those bonds.

P_s is now computed as in Equation 3.2;

$$P_s = B_m \bar{\mu} - (B_m - B_0) \mu^{*} (1 - e^{-\bar{\mu}/\mu^{*}}) \quad (3.11)$$

where

$$\bar{\mu} = \eta_z \mu^{*} + \Delta \quad (3.12)$$

and

$$\mu^{*} = \mu^{*} / [\eta_z (1 - \alpha_2 e^{\alpha_2 \mu_m^{*} / \epsilon_z}) + \alpha_1 e^{-\alpha_1 \mu_m^{*} / \mu_1}] \quad (3.13)$$

The assumption that unloading paths for partially collapsed porous media parallel the solid load-unload path has been used for many earth media, particularly when load-unload data were not available or inconsistent. Recommended load-unload paths for the porous shales provided by WES did not conform to this behavior. Unloading from peak pressures less than the elastic toe were elastic; as the peak pressure increased above the crush level so did the initial unload moduli. Thus the unloading paths appear to stiffen and fan out as the peak pressure increases. This effect was modeled by simply adjusting the effective maximum excess compression as the material unloaded, i.e., for $\mu_{x_1} < \mu_m < \mu_{x_2}$,

$$\mu_m' = f \mu + (1-f) \mu_m \quad (3.14)$$

where

$$f = (\mu_m - \mu_{x_1}) / (\mu_{x_2} - \mu_{x_1}) \quad (3.15)$$

and μ_{x_1} and μ_{x_2} are input. Thus, for a porous solid, six additional parameters must be specified, namely;

- ρ_0 = the initial density of the material ($\neq \rho_r$)
- α_1 = relative slope of initial loading on the elastic toe to that of the non-porous solid

- μ_1 = amount of compression on loading toe
- α_2 = fitting parameter governing the elastic slope of the load curve while crushing out the voids
- μ_{x1} = minimum compression to begin fanning the unload paths
- μ_{x2} = compression where unload path parallels zero porosity load-unload curve.

3.2.1.3 Solid-Solid Phase Change. Many materials exhibit a solid-solid phase change under compression. Based on Hugoniot and release data for silicates, it appears that under shock loading such a change is hysteretic, i.e., on unloading the material initially remains in the higher density state and does not revert to the original state until well down the release path. Such behavior can be modeled by assuming that the phase change is a function of both compression and energy.

To compute the new solid P_s , Equation 3.2 or 3.11 is again modified by replacing the constant B_m and the excess compression, μ' (Equation 3.4) or $\bar{\mu}$ (Equation 3.12), by

$$B'_m \text{ and } \mu' - \Delta, \text{ or } \bar{\mu} - \Delta\rho \quad (3.16)$$

where

$$\Delta\rho = \begin{cases} 0 & \rho E \leq (\rho E)_1 \text{ (all state 1)} \\ g\mu_2 & \rho E > (\rho E)_1 \end{cases} \quad (3.17)$$

$$B'_m = \begin{cases} B_m & \rho E \leq (\rho E)_1 \text{ (all state 1)} \\ B_m + g(B_{m2} - B_m) & \rho E > (\rho E)_1 \end{cases} \quad (3.18)$$

and

$$\mu_2 = \rho_2 / \rho_r - 1,$$

$$g = \frac{1 - e^{-\alpha_3[\rho E - (\rho E)_1]}}{1 + e^{-\alpha_3[\rho E - (\rho E)_1]}} \quad (3.19)$$

and B_{m2} , $(\rho E)_1$, ρ_2 and α_3 are material constants. Thus, four additional input parameters are required for the phase change:

- ρ_2 = the reference density of the 2nd phase
- $(\rho E)_1$ = the energy per unit volume at which the phase change begins

- α_3 = a parameter setting the rate of conversion between the phases
 B_{m2} = the maximum bulk modulus ($dp/d\mu$) of the 2nd phase.
 NOTE: B_{m2} is relative to ρ_r of the 1st phase; the modulus relative to the zero pressure density of the 2nd phase, ρ_2 , is $B_2 = (\rho_2/\rho_r) B_{m2}$

3.2.1.4 Deviatoric Behavior. The complete description of a material's stress-strain behavior requires the calculation of the deviatoric stress tensor, σ'_{ij} , in addition to the mean stress or pressure.

The SHEL EOS model assumes that the stress deviators depend on the strain deviators, ϵ'_{ij} , and a yield function, Y . The stresses are calculated in two steps. First, the change in the deviators is assumed to be elastic and an incremental change is added to the previous deviators,

$$\sigma'_{ij}(n) = \sigma'_{ij}(n-1) + 2Gd\epsilon'_{ij} \quad (3.20)$$

where G is the shear modulus of the material and $d\epsilon'_{ij}$ is the change in the ij -th component of the deviatoric strain tensor between times $n-1$ and n . Furthermore, it is assumed the shear modulus can be derived from the current bulk modulus through Poisson's ratio and the standard elastic relation

$$2G = 3B(1 - 2\nu) / (1 + \nu) \quad (3.21)$$

After the stresses have been updated by Equation 3.20 a check is made to see if the elastic changes are valid. The second invariant of the deviatoric stress tensor, J'_2 is compared to the square of a yield function, Y which depends only on the mean stress, P . If J'_2 exceeds Y^2 , the material is deforming plastically and the deviators are proportionally reduced so that J'_2 is equal to Y^2 . For the rock media of interest, the yield function is

$$Y = Y_{vm} - (Y_{vm} - Y_0)e^{-P/P_y} \quad (3.22)$$

The four input parameters required to calculate the deviatoric stress tensor are;

- ν , Poisson's ratio
- Y_{vm} , the limiting yield strength (kb)
- Y_o , the yield strength at zero pressure (kb)
- P_y the pressure at which the yield function $\sim(2/3 Y_{vm} + 1/3 Y_o)$, (kb)

Table 3-5. Equation-of-state parameters for SHEL (EOS 1).

<u>Value</u>	<u>Units</u>	<u>Name</u>	<u>CK Location</u>	<u>Comments / Definition</u>
ρ_o	g/cc	RHOZ		Initial density
ρ_r	g/cc	RHOREF		Reference density
E_s	Terg/g	ES		Min energy for P_v
B_o	Mb	BO		Initial bulk modulus
B_m	Mb	BM		Maximum bulk modulus
μ^*	--	XMU		Rate of change of B
μ_1	--			End of elastic toe
α_1	--			Rate of increase of B on elastic toe
α_2	--			Rate of increase of B during pore collapse
μ_{x1}	--			Start of unload path fan
μ_{x2}	--			End of unload path fan
ρ_2	g/cc			Ref density of higher density phase
$(\rho E)_1$	Te/cc			Min E/V for solid in 2nd phase
B_{m2}	Mb			Max B of 2nd phase solid
α_3	--			Rate for solid-solid phase change
V_v	%			Porosity (total void volume)
β	g/Terg	CTE		Thermal expansion coef.
ν	--			Poisson's ratio
Y_{vm}	Mb			Von Mises yield limit
Y_o	Mb			Cohesion
P_v	Mb			Coef. in Rate of increase in Y with P

3.2.2 VIC.

Table 3-6. Equation-of-state parameters for VIC (EOS 2).

<u>CK</u>	<u>VALUE</u>	<u>I/M</u>	<u>UNITS</u>	<u>DEFINITION</u>
1	A		--	$\gamma-1$ of vapor phase
2	B		--	Coef of 2nd vapor term
3	EO		Te/g	Parameter in vapor term
4	ESS		Te/g	Energy of incipient vaporization
5	ESP		Te/g	Energy of complete vaporization
6	ALPHA		--	Exponential decay coef
7	BETA		--	Exponential decay coef
8	AA		Mbar	Bulk modulus at zero P
9	BB		Mbar	Coefficient of μ^2 term
10	GM		Mbar	Max Shear modulus
11	POIS		--	Poisson's Ratio, γ
12	GOK		--	$G/K [=1.5(1-2\nu)/(1+\nu)]$
13	DELE			$1/(ESP-ESS)$
14-16				
17	AP		Mbar	AA after phase change
18	BP		Mbar	BB after phase change
19	EPM		Te/g	Min. E for solid-solid phase change
20	EPP		Te/g	Max. E for solid-solid phase change
21	DEP		--	Δ of phase change
22-27				
28	BETAH		--	Rate of hardening of Y
29	BETAS		--	Rate of softening of Y
30	EPYLD		--	Plastic μ where hardening ends
31	YFLOWR			Flow rule sentinel (0=non-assoc., 1= assoc.)
32	YLDMXF		Mbar	Von Mises limit if fractured (def=YLDMXC)
33	YLDMXC		Mbar	Von Mises yield limit, ($J_3' > 0$)
34	COHC		Mbar	Cohesion of competent material ($J_3' > 0$)
35	DYDPC		--	dY/dP in compression ($J_3' > 0$)
36	YLDMXE		Mbar	Y_{max} in extension (J_3')
37	COHE		Mbar	Cohesion in extension (J_3')
38	DYDPE		--	dY/dP in extension (J_3')
39	COHF		Mbar	Cohesion of 3-cracked material (def=COHC)
40	DYDPF		--	dY/dP after 3-cracks (def=DYDPC)
41-48				
49	VREF		cm^3/g	$1/RHOREF$
50	NEOS		2--	EOS # for VIC

3.2.3 CIST.

Subroutine CIST is a relatively simple EOS developed at the AFWL⁵ to model the results of Cylindrical In-Situ Tests (CIST) field data. It has been used for both low and high stress calculations, such as those in Reference 12. The current CRALE version uses the AFWL model for the pressure-density relation, but calculates the energy dependence in the same way as the SHEL EOS. Low pressure loading and unloading occur along straight line segments determined by the sets of input wave speeds, C1, C2, C3, pressure limits, P1, P2, P3, and Poisson's ratios PRL and PRU. For pressures greater than P3, the routine uses a quadratic similar to the SHEL EOS, i.e.,

$$P = P_3 + B_1(\mu - \mu_3) + B_{sq}(\mu - \mu_3)^2 \quad (3.23)$$

At high energy densities, an additional term is added to the pressure. This term is calculated in the same way as in subroutine SHEL (Equations 3.1 through 3.4).

⁵ AFWL ref

Table 3-7. Equation-of-state parameters for CIST (EOS 3).

CK	VALUE	I/M	UNITS	DEFINITION
1	C1	Y	cm/ms	Unload and initial load wave speed
2	C2	Y	cm/ms	2nd loading wave speed
3	C3	Y	cm/ms	3rd loading wave speed
4	P1	Y	Mbar	P where C changes from C1 to C2
5	P2	Y	Mbar	P where C changes from C2 to C3
6	P3	Y	Mbar	P where load/unload curves merge
7	BSQ	Y	Mbar	Coef. of μ in high pressure fit
8	ALFA	Y		Controls slope of unloading heel
9	EMU3	Y	--	μ where load/unload curves merge
10	EMU2	Y	--	μ at P2
11	EMU1	Y	--	μ at P1
12	EMUMX	Y	--	μ at P=0 along max unload curve
13	B1F	M		Ratio of initial K to B1 (def=1.)
14	B1	Y	Mbar	dP/d μ corresponding to C1
15	B2	Y	Mbar	dP/d μ corresponding to C2
16	B3	Y	Mbar	dP/d μ corresponding to C3
17	CTE	Y	g/Te	β , the Coefficient of thermal expansion
18	EV	Y	Te/g	Min. vaporization energy (> ES)
19	FPRL	Y	--	$f_L = 1.5(1-2v_L)/(1+v_L) = G/K$ [loading]
20	FPRU	Y	--	$f_U = 1.5(1-2v_U)/(1+v_U) = G/K$ [unloading]
21-22				
23	BETA	Y		Controls break on unloading for heel
24				
25	PRL	Y	--	Loading Poisson's ratio, v_L
26	PRU	Y	--	Unloading Poisson's ratio, v_U
27	GMAX	Y	Mbar	Maximum shear modulus
28	BETAH	I	--	Rate of hardening of Y
29	BETAS	I	--	Rate of softening of Y
30	EPYLD	I	--	Plastic μ where hardening ends
31	YFLOWR	I		Flow rule sentinel (0=non-assoc., 1= assoc.)
32	YLDMXF	I	Mbar	Von Mises limit if fractured (def=YLDMXC)
33	YLDMXC	I	Mbar	Von Mises yield limit, ($J_3' > 0$)
34	COHC	I	Mbar	Cohesion of competent material ($J_3' > 0$)
35	DYDPC	I	--	dY/dP in compression ($J_3' > 0$)
36	YLDMXE	I	Mbar	Ymax in extension ($J_3' < 0$)
37	COHE	I	Mbar	Cohesion in extension ($J_3' < 0$)
38	DYDPE	I	--	dY/dP in extension ($J_3' < 0$)
39	COHF	I	Mbar	Cohesion of 3-cracked material (def=COHC)
40	DYDPF	I	--	dY/dP after 3-cracks (def=DYDPC)
41-48				
49	VREF	Y	cm ³ /g	1/RHOREF
50	NEOS	Y	3	the material uses the CIST EOS

3.2.4 HE.

A model for High Explosives, air, simple gases or mixtures of HE and air.

HE is a combination of the Lawrence Livermore National Laboratory (LLNL) JWL⁶ model for high explosives and an AFWL⁷ variable-gamma or constant-gamma, perfect-gas model of air. For HE, the JWL model calculates pressure as the sum of three terms, a gamma-law gas plus two terms which decay exponentially with increasing volume; namely;

$$P = A * (1 - \omega / R_1 v) e^{-R_1 v} + B * (1 - \omega / R_2 v) e^{-R_2 v} + \omega p E \quad (3.24)$$

Values of the JWL parameters for several typical HEs are given in Table 3-8 and defined in Table 3-9. The input data for the JWL model are stored in CK 1-8. Note the input units for E_0 , the initial explosive energy [CK(7)] are Te/cc rather than the code units of Te/gm. This choice was made to retain consistency with general usage. If CK1 is 0., the material is assumed to be air or a perfect gas; Equation. 3.24 is skipped and the air or perfect gas algorithm is used.

The release adiabat for TNT, shown in Figure 3-1, illustrates the effect on the total pressure of each term on the right-hand side (rhs) of Equation 3.24. Both the first (A-term) and second (B-term) parts of the rhs of Equation 3.24 decay very rapidly as the HE products expand. As shown in Figure 3-1, both terms become insignificant relative to $\omega p E$ at volumes greater than about 5 cc/g, well above the densities usually attained in air or similar gases. Hence at large volumes the JWL model reduces to a simple, constant- γ law gas, where $\omega = \gamma - 1$. Because many problems of interest involve HE explosions in air, modeled as a variable- γ gas, the JWL model has been modified so that at large volumes the effective γ transitions from the JWL value to that calculated by the AFWL algorithms.

The transition from the JWL gamma to that of air begins at the density where the B-term is less than $PCUT$, currently set to 10^{-3} bars, i.e.;

$$\rho_b = R_2 \rho_0 / \log_e [PCUT/B] \quad (3.25)$$

⁶ LLL HE reference

⁷ AFWL ref for air EOS

and is equal to the air γ for densities less than or equal to .01 g/cc, about a factor of ten greater than ambient air. A linear interpolation in density is used to go smoothly from one ω to the other. By allowing ω to vary as a function of the gas density, a single EOS may be used for pure HE, pure air, or a mixture of the two. This is convenient when calculating an HE explosion in air since the boundary between the two materials may then be treated as non-Lagrangian.

If *AGAM* is set to zero, the routine assumes the material is pure explosive; if *AGAM* is greater than zero, the material will be calculated either as pure air [*HEGAM* = 0] or a mixture of explosive and air (*HEGAM* > 0). If *AGAM* is not zero, EOS HE will use the AFWL variable gamma model for the gas. To model a constant gamma-law gas, set *AGAM* to 1., *HEGAM* to 0., and *GAMPG* to the desired value of $\gamma-1$.

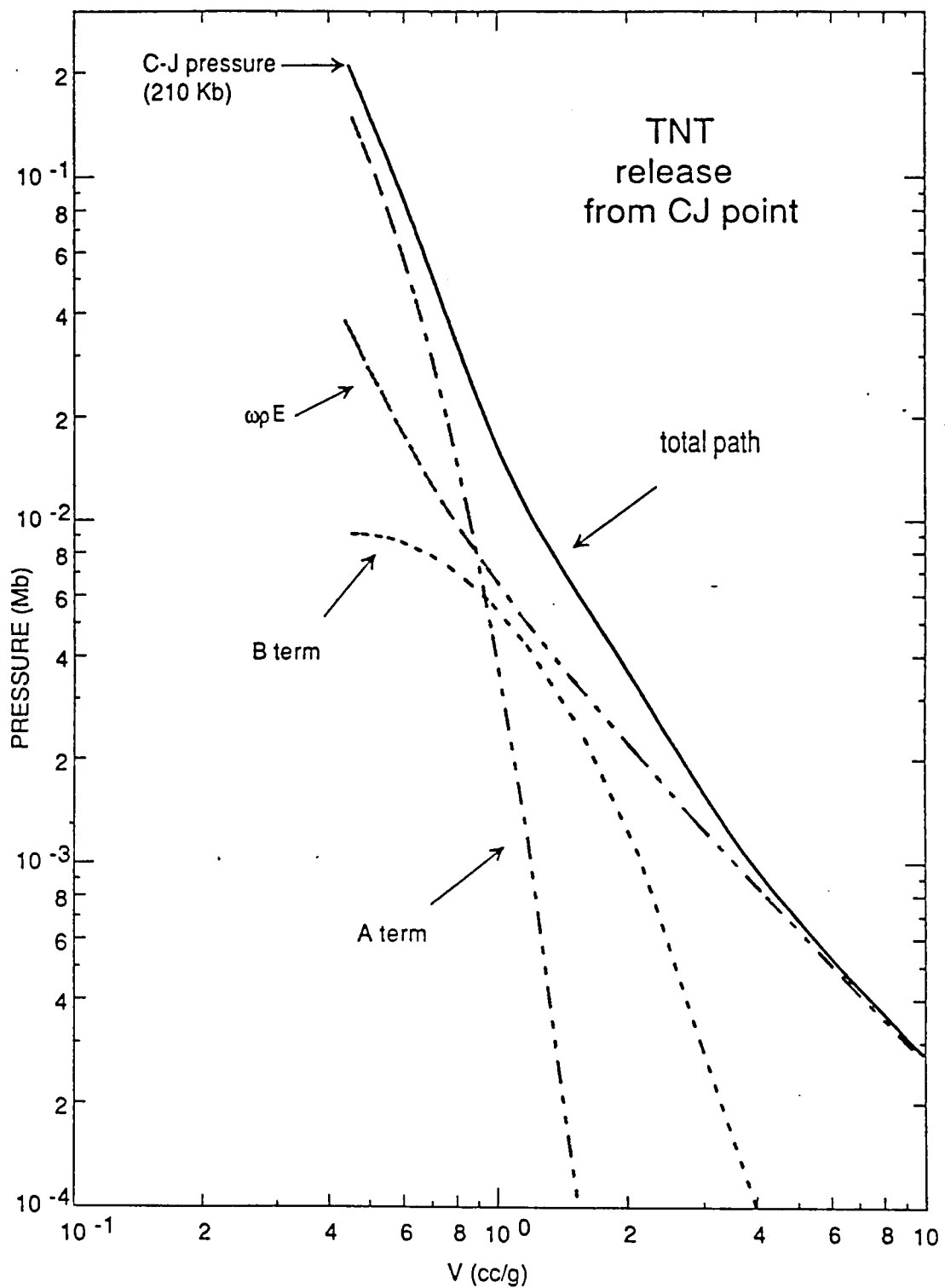

Figure 3-1. Release Path from the CJ point of TNT showing the contributions of the three terms in the JWL EOS.

Table 3-8. JWL parameters for some common high explosives.

HE type	ρ_0 g/cc	P_{CJ} kb	E_0 Te/cc	D cm/s	ω ($\gamma-1$)	A Mb	$R1$	B Mb	$R2$
TNT	1.63	210	.06	.693	.35	3.738	4.15	.03747	0.90
NM	1.128	125	.051	.628	.30	2.092	4.4	.05689	1.2
NM1	1.139	125	.050	.6187	.27	1.922	4.3	.0631	1.3
ANFO	0.82	55	.0315	.455	.31	0.4716	3.7	.009536	0.95
PETN	1.77	335	.101	.83	.25	6.17	4.4	.16926	1.2
9404	1.84	370	.102	.88	.25	8.545	4.6	.20493	1.35

Table 3-9. Equation-of-state parameters for HE (EOS 4).

CK	VALUE	I/M	UNITS	DEFINITION
1	HEGAM	I		$\omega = \gamma-1$ for High Explosive
2	A	I	Mb	parameters of the
3	R1	I		J-W-L (LLL) equation
4	B	I	Mb	of state, Equation 3.24
5	R2	I		(set $\omega = 0$ for EOS of air)
6	DETV	I	cm/ μ s	Detonation velocity
7	EPOT	I	Te/cm ³	Potential energy released on detonation (divide by ρ_0 to get specific energy, EZ)
8	CJP	I	Mbar	Chapman-Jouguet Pressure
9	AGAM	I		= 0 for HE only; = 1 for air or mix of air-HE
10	GAMPG	I		if $\omega = 0.$, value of $\gamma-1$ for perfect gas
11-16				not used
17	-A1	M	g/cm ³	Coef. of ρ in A term, Equation 3.24
18	A2	M	cm ³ /g	HEGAM/A1
19	CUTA	M	g/cm ³	-A1/LOG(10 ⁻⁹ /A)
20	B1	M	g/cm ³	Coef. of ρ in B term, Equation 3.24
21	B2	M	cm ³ /g	HEGAM/B1
22	CUTB	M	g/cm ³	-B1/LOG(10 ⁻⁹ /B)
23	CUTC	M	g/cm ³	.01, lower density limit for HE / air mixture
24-30				not used
31	CJMU	M		excess compression, μ , at CJ point
32	CJGAM	M		effective $\gamma-1$ at CJ point
33-48				not used
49	VREF	M	cm ³ /gm	1/RHOREF
50	NEOS	M	4.	- the material uses the HE EOS

3.2.5 MCST.

A multi-segmented "stick" model based on the CIST model has been constructed, primarily to fit the behavior of the Socorro plaster sand used in numerous tests at the DNA PHETS site at White Sands. The model is quite flexible and is also used to model concrete. For details contact Jim Rocco at the TRT in Albuquerque.

3.2.6 SCUB.

This module is currently inactive. It has served in the past as the location for the table lookup routines provided by SCUBED for material models used in their early time cratering calculations in several DNA programs, e.g., Benchmark Cratering and MISTY ECHO. Since SCUBEDs EOS models are also dynamic, it is recommended that they be contacted for their current model if it is to be used in CRALE or EQS calculations.

3.2.7 H₂O.

H₂O contains the SAIC 1983 model for water. This model was incorporated to compare with others and is not recommended for use without further study.

3.2.8 UEOS.

UEOS is an empty routine included to provide the hooks by which users may easily incorporate their own EOS model into CRALE.

3.2.9 CAP.

The CAP EOS currently in use in CRALE was developed by Dr. George Baladi while at the Waterways Experiment Station (WES). It is a strain dependent model in that the complete stress tensor is updated each cycle based on the current stress state and the incremental change in strain. The model also calculates the shear modulus, G, at the average strains rather than using an initial or final value as is required when G is a function of P. A problem with previous CAP models was their sensitivity to step size. Baladi's model reduced this condition by using the average moduli on each cycle.

Table 3-10. Equation-of-state parameters for CAP (EOS 9).

<u>CK</u>	<u>VALUE</u>	<u>I/M</u>	<u>UNITS</u>	<u>DEFINITION</u>
1	AKEI	Y	MPa	Used to calculate K
2	AK1	Y	"	" " "
3	AK2	Y	"	" " "
4	AK3	Y	"	" " "
5	AK4	Y	"	" " "
6	AK5	Y	"	" " "
7	AK6	Y	"	" " "
8	AK7	Y	"	" " "
9	AKIM	Y		Used for pore pressure K
10	AK1M	Y	"	" " " "
11	AK2M	Y	"	" " " "
12	AA	Y		Maximum Yield stress
13	AB	Y		Coef in exp change of Y
14	AB1	Y	"	" " " " " "
15	AC	Y		Cohesion = AA-CC
17	AGEI	Y		Used to calc G (Shear Mod)
18	AG1	Y	"	" " " " " "
19	AG2	Y	"	" " " " " "
20	AG3	Y	"	" " " " " "
21	AG4	Y	"	" " " " " "
22	CRO	Y		Cap parameter
23	CR1	Y	"	" "
24	CR2	Y	"	" "
25	AW	Y		Maximum hysteretic strain
26	AD	Y		Used to calc hysteretic strain
27	AD1	Y	"	" " " " " "
28	AD2	Y	"	" " " " " "
29	AD3	Y	"	" " " " " "
30	AD4	Y	"	" " " " " "
33	SJMX	Y		Pressure switch to hi-P EOS
34	CKMX	Y		Maximum bulk modulus
35	CKAA	Y		exp rate of increase to CKmx
36	LTYPE	Y		=1, cap retracts; =2, fixed
41	ASTART			Initial position of L
42	XSTART			Initial Position of X
43	FCUT			Max Tensile pressure
44	TCUT			Tensile cutoff

3.2.10 MIX.

Table 3-11. Equation-of-state parameters for MIX (EOS 10). (Table to be included in next issue of manual)

3.2.11 Others.

Over the years of using AFTON and CRALE a number of EOS models have been incorporated in various PL's. Several may still be included on the current PL, but their use would require some preliminary testing to insure that they still are operational. They are included here for completeness.

3.2.11.1 TILL. TILL is a modified version of the TILLOTSON EOS⁸. This EOS was derived originally for very high pressures in metals. For densities greater than the initial RHOZ, the pressure is calculated as

$$P = A\mu + B\mu^2 + \left[a + b / \left(E / E_0 \eta^2 + 1 \right) \right] \rho E \quad (3.26)$$

If a Poisson's ratio (POIS) and nonzero value of Gm, and the maximum allowable shear modulus are specified, TILL will return the elastic moduli to STRAIN so deviatoric stresses may be computed. The TILL EOS will not, however, treat hysteretic or plastic materials. Although it has been used for rocks, the low stress regime (CIST).

3.2.11.2 GRAY. The GRAY⁹ EOS is a version of the routine developed by LLNL for metals. It does not have deviatoric components and may give erroneous results at very high pressures.

⁸ J. Tillotson, "Metallic Equations of State for Hypervelocity Impact", GA-3216, General Atomic, July 1962.
⁹ E.B. Royce, "GRAY, A Three-Phase Equation of State for Metals", UCRL-51121, LLL, Sept. 1971.

SECTION 4

EQS – THE EQUATION OF STATE DRIVER

4.1 OVERVIEW.

EQS is a stand-alone program designed to exercise the EOS models described in the previous sections that are used in the 1- and 2-D CRALE codes. The program has a number of options for both specific and arbitrary stress-strain paths and generates plots for easy comparisons with various types of material properties data.

An important feature of EQS is its conformity with the CRALE codes. Input data for the various EOS models are read using EQST, the same routine called by CRALE1 and CRALE2. The major subroutines in EQS generate the desired stress-strain paths by first setting up an axisymmetric unit cell in the 2D code, prescribing the appropriate motions of that cell's corners, and then calling the CRALE2 subroutine STRAIN to calculate the incremental strains and resulting stresses. Thus, once a model has been checked out with the driver, the same behavior should be followed in the 1D and 2D codes. (However, note that since EQS only exercises a single j,k cell in a pseudo-2D CRALE grid, subtle errors in setting local variables could still occur in the FD codes.)

The current EQS program stores up to 200 complete sets of stress-strain data (σ , ε , ρ , E, moduli, speeds, etc.) for each Hugoniot, release adiabat or strain path generated by HUG, REL, PATH or FLIP and experimental data (σ , ρ , U_p , U_s , E) for each call to EXP or EQN. Each data set is identified by a line number [LINES] and is referred to as such when needed by subsequent calls to other routines. After the data sets have been produced, selecting the PLOT option provides the flexibility to overlay data for different EOS's and/or the experimental Hugoniot data or fit on a single plot. The data may also be written to an output file for further analysis by other programs.

4.2 CODE MODULES.

4.2.1 EQS, the Main Program.

The main program, EQS, serves as the interface between the user and the various routines that generate the data sets and plots. The basic flow of the EQS program is illustrated by the schematic flowchart in Figure 4-1; the input file required to run EQS is summarized in Table 4-1. Details of the input as used by each subroutine are described in the subsections detailing that routine. EQS is quite fast, typically completing a run in under 30 seconds on a 486 PC. Hence, the remainder of this section assumes the operations occur on a PC. The code will run in batch mode on the DNA workstations and CRAY computers with only minor differences.

EQS begins by calls to several subroutines that initialize the run. The first call to **OPNFIL**, opens the appropriate I/O and data files. Currently the various files that may be required during execution are;

Unit No.	PC File Name	Purpose
2	'name'.ZTA	contains the plot output
3	EOSS.DAT	A data base of specific material EOS input
5	'name'.INP	The input file read by EQS
6	'name'.OUT	The standard output file
10	HUGROCK.DAT	Experimental Shock data for rocks, grouts, H ₂ O
11	HUGMET.DAT	Experimental Shock data for metals, plastics, etc.
12	RELAD.TXT	Release Adiabatic data from SNL Hugoniot points
14	USUP.DAT	Data base of fits to U _s -U _p on the Hugoniot.

where 'name' implies a file name supplied by the user.

EQS obtains its operating instructions from an ASCII input stream constructed by the user as a *name.inp* file. Line 1 of the input (see Table 4.1) includes a user ID (**PLTNAM**), a switch (**ICNV**¹) to set the I/O units (default = Mb-g- μ s) and controls for including a logo on the plot output (**NLOGO, XLPLT, YLPLT, SIZEL**). The code

¹ Although the ICNV parameter may be used to set the I/O units, some output, particularly when printed using the 'F-type format, remain in code units (Mb-g- μ s). Wave speeds and moduli in HUG, for example, are printed in code units, i.e., cm/ μ s and Mb.

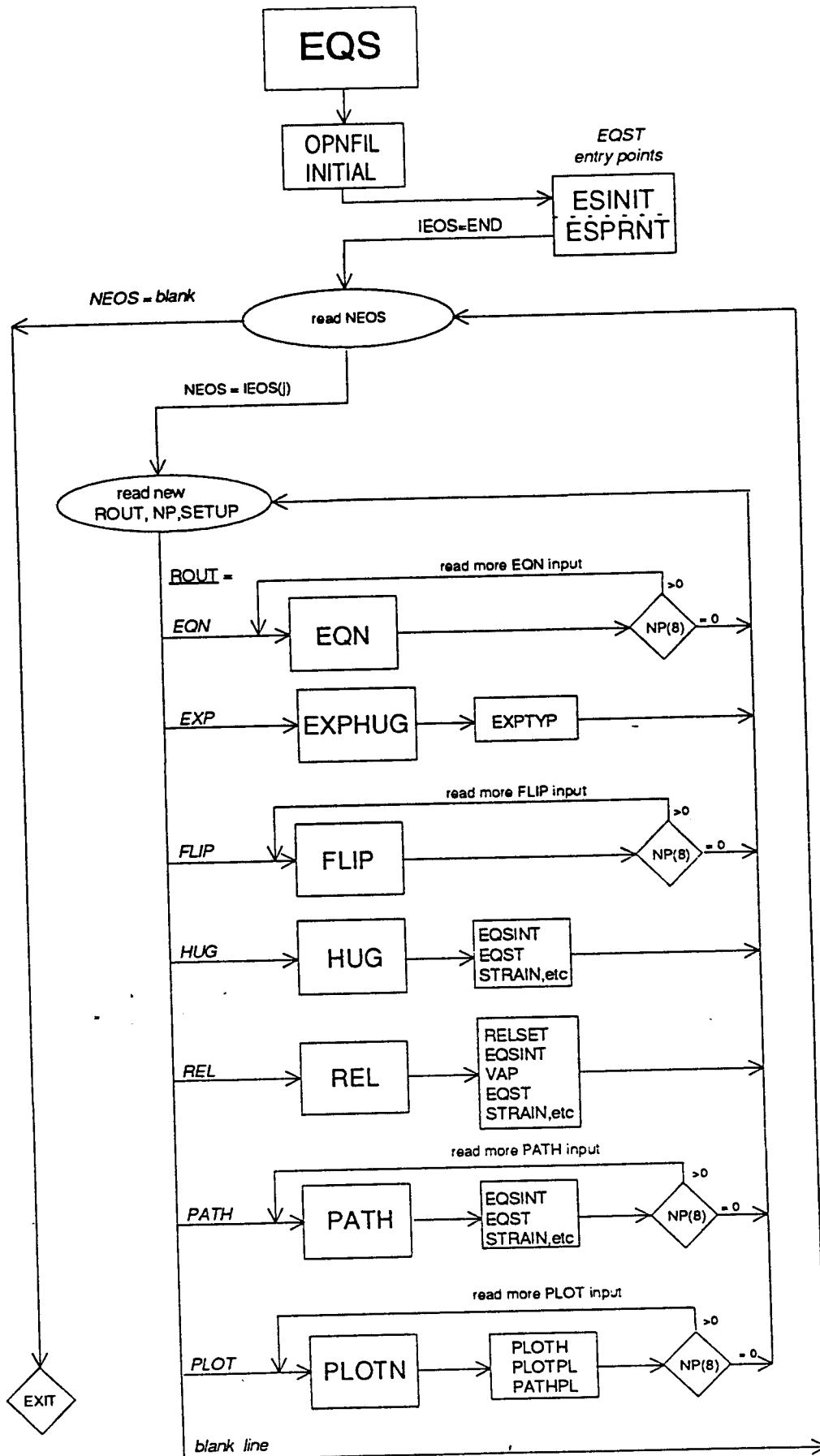

Figure 4-1. Flowchart of EQS, the equation of state driver routine.

continues with a call to **INITIAL**, a general CRALE routine that initializes parameters, such as π and the I/O units to be used in the run. Although eight sets of units are available, if *ICNV* is set to 9 or 10, **INITIAL** will read in two lines containing the desired conversion factors from code to I/O units and corresponding names. While the code uses a consistent set of units in its calculations, these I/O units may be completely arbitrary. The CRALE utilities library contains a routine to draw the TRT logo. Other logos can be added to the library and then placed on EQS plots by setting *NLOGO* greater than zero. *XLOGO*, *YLOGO* and *SIZEL* can be set to position the logo and adjust its size from the defaults.

Table 4-1. Summary of the input to EQS.

line 1	FORMAT (A4, 2I2, 12X, 3F5.0)
PLTNAM	4 Character ID for plots
ICNV	Specifies I/O units; default is Mb-gm- μ s
NLOGO	0= omit logo from plots; 1=plot TRT logo; 2=?
XLOGO	X position of logo on page, {def= left edge of page}
YLOGO	Y position of logo on page, {def= 2' from top of page}
SIZEL	Size of logo, {def=.5"}
line 2	EOS data input; see Section 2.5
line 3	FORMAT (A8, 2X, 18A4)
NEOS	Name of EOS to be exercised; blank terminates the run. 'DATA' may be used for NEOS for calls to PLOT, EQN or EXP.
TITLE	Title for succeeding print and plot output
line 4	FORMAT (A4, 8I2, 12F5.0) see Table 4.2
ROUT	Name of EQS subroutine to be exercised
NP	8 integer parameters for the various subroutines
SETUP	Up to 12 floating point parameters for the various subroutines
line 5	Additional data lines read in EQN or PATH

At this point EQS is ready to process the user input. The program continues with calls to two entry points in the **EQST** subroutine, **ESINIT** which reads in the parameters of the EOS models required for the run (lines 2) and **ESPRNT** which echoes them to the *name.out* file. **ESINIT** will read data for up to 15 different materials, each uniquely identified by name [*IFOS(i)*]. (At least one material model must be read.) The EQST input was discussed in Section 3.1 and is summarized in Tables 3-1 and 3-2.

After the material models are read, EQS can finally cycle through the sets of user requests for information. Each set of input data begins with line 3 containing the name of the material (*NEOS*) to be acted on and an optional title (*TITLE*) for print and plot output. The code checks to be sure the material requested was one of the EOS models read in. (The word *DATA* will also be accepted as a valid *NEOS* to process the experimental data base.) If the requested *NEOS* is not available, the code prints an error message and aborts. For a valid *NEOS*, EQS reads the input on line 4 containing a router (*ROUT*), and as many as 8 integer (*NP*) and 12 floating point (*SETUP*) parameters.

ROUT determines which subroutines to activate and *NP* and *SETUP* activate the various options and set the parameters required by that routine as summarized in Table 4-2. Several of the subroutines (e.g., *EQN*, *PATH*) may ask for additional input, line 5, which is read in next. The formats for these data are included in the subsections describing those routines. After completing the desired operations, the code loops back to read another line 4 and performs the next request. A blank line 4, i.e., *ROUT*=' ', causes the code to loop back to read another line 3 with the next material model to process. The end of the run is signaled by a blank line 3, i.e., *NEOS*=' '; the code closes all open files and terminates. The current choices for *ROUT* are;

<u>ROUT</u> =	<u>Routine</u>	<u>Sect</u>	<u>Function</u>
<i>EQN</i>	<i>EQN</i>	4.2.2	generate the Hugoniot data set using U_s-U_D or $P-U_D$ relation from least-squares fit to <i>EXP</i> data set or database
<i>EXP</i>	<i>EXPHUG</i>	4.2.3	Retrieve experimental Hugoniot and release adiabats from the DNA shock database
<i>FLIP</i>	<i>FLIP</i>	4.2.4	Flip and translate Hugoniots to get shock interactions and BCFs ²
<i>HUG</i>	<i>HUG</i>	4.2.5	Generate principal Hugoniot for selected EOS model
<i>PATH</i>	<i>PATH</i>	4.2.7	Generate σ_{ij} vs ϵ_{ij} for arbitrary stress- or strain-driven paths
<i>PLOT</i>	<i>PLOTN</i>	4.2.8	Plot previously data sets in several standard forms
<i>REL</i>	<i>REL</i>	4.2.6	Generate release adiabats from points along the last Hugoniot or exercise model for specific μ, E pairs.
blank			Close files and terminate run

A more complete description of the *NP* and *SETUP* input parameters is included in the discussion of the individual routines, Section 4.2.2 through 4.2.8.

² Borehole Correction Factors

Table 4-2. Parameters on line 4 of EQS input.

ROUT	NP (8I2)								SETUP (12F5.0)					
	1	2	3	4	5	6	7	8	1	2	3	4	5	6
(A4)	LINE	LEX	iHEL						EDIT1	RHOMIN	RHOMAX			
EQN	LINE	0,1	LINEQ						RHOO	UMN	UMX			
		2,3					NPP		C1	C2	C3	UMMIN	PMAX	
		4							ENUM	AUT	RHOO			
FLIP	LINE	L1		0,1					U(i) or P (I), i=1,12					
			--	2			NPP		U(i) & P (i), i=1,6					
HUG	LINE		L2	--				P2MIN	P2MAX	PINC				
REL	--	0	E-iter	PH				PUP	YVEL	GSY				
		1,2						PTOP	PSAV2	PSAV3	PSAV4	PSAV5	PSAV6	
		3						μ	ENG	σ'				
PATH	LINE							ENG	CTE					
PLOT	2	LINE	lin/log	LTYP P vs ρ, η, ϵ, V	HUG: hydrost EXP: ref list	line type	COLOR	NPP	PLXL	PLYL	PLXMN	PLXMX	PLYMN	PLYMX
	3													
	4		ref ad	ref list	line type	COLOR	NPP							
	5													
	6													
	>10													

4.2.2 EQN.

For ROUT=EQN, subroutine EQN is selected to produce a Hugoniot derived either by fitting a previous data set either 1) generated by EXPHUG [NP(2)≤1] or 2) from input of the coefficients of a quadratic fit to U_s-U_p [NP(2)=2] or P-Up [NP(2)=3] curves or 3) from a fit stored in the U_s-U_p DNA data base on Unit 14 [NP(2)=4]. The input to EQN, summarized in Table 4.2, is as follows;

NP

- | | | |
|---|------|--|
| 1 | LINE | User Reference Number of data set for plotting, etc |
| 2 | IEQ | = 0, 1; obtain least squares fit (LSF) of U_s-U_p data for line NP(3)
2; generate Hugoniot from LSF to U_s-U_p input
3; " " " " " P-Up input
4; read U_s-U_p fit from <i>USUP.dat</i> data base (Unit 14) |
| 3 | LIN | identifier of previous data set to be fit, <u>needed</u> if <u>NP[2] ≤ 1</u> |
| 8 | NPP | if > 0, line is segmented, read additional data (line 5) see below |

for NP[2] ≤ 1 get least squares fit for LIN; generate Hugoniot data set

SETUP

- | | | |
|---|------|-------------------------------------|
| 1 | RHOO | Initial density, only J=1 is needed |
| 2 | UMN | Minimum U_p on segment |
| 3 | UMX | Maximum U_p on segment |
- if NPP > 0; read in one additional line (1X, F9.0, 7F10.0) with UMX(i), i=1,8

for NP[2] = 2, 3 read in U_s-U_p or P- U_p relation and generate data set

SETUP

- | | | |
|-------|-------|--|
| i = 1 | RHOO | Initial density, only input for J=1 is needed |
| 2-4 | Ci | where $\Phi = C_0 + C_1 U_p + C_2 U_p^2$ and
$\Phi = U_s$ if NP[1]=2; P if NP[1]=3. |
| 5 | UPMIN | Minimum U_p on segment {0.0001 cm/ μ s} |
| 6 | PMAX | Maximum U_p or P on segment if NP(1)=2 or 3 {50 Mb} |
- if NPP > 0; read additional lines (11, F9.0, 5F10.0) containing
NPP, C1, C2, C3, UPMIN, PMAX until NPP=0.

for NP[2] = 4 read in U_s-U_p from data base on Tape 14

SETUP

- | | | |
|---|------|---|
| 1 | ENUM | Material number in data base (See Table 5-3.) |
| 2 | IAUT | Author ID |
| 3 | RHOO | Initial density |

NP[2]≤1: EQN finds the data set corresponding to LIN=NP[3] and does a least squares fit to find the linear U_s-U_p relation,

$$U_s = C_0 + sU_p \quad (4.1)$$

and the standard deviation, σ , of the fit. The U_s-U_p data may be fit in up to 8 intervals. If NPP \neq 0, EQN reads a line of data (8F10.0) containing the UMX of each interval [The UMX of each interval is the default UMN for the next, the initial UMN=SETUP(2).] The routine generates and saves the full set of Hugoniot parameters, including $dP/d\mu$ (defined as $[dP/dU_p]/[D\mu/dU_p]$). The output includes a comparison of the shock P and U_s calculated by the fit with the those in the data set used for the fit. EQN then removes all data that are outside the $\pm 3\sigma$ bounds of the fit and refits the remaining points. This fit is not saved but a printout comparing it to the data is also generated.

NP[2]=2 Or 3: As an alternative, EQN will generate a complete set of Hugoniot data from a linear or quadratic fit for either U_s-U_p (NP[2]=2) or $P-U_p$ (NP[2]=3). Either of these fits, again, may be comprised of up to 10 segments. The initial density, SETUP [1], and the three coefficients of the fit, SETUP[2-4], are input along with the ends of the fit and the geometric increment (ΔU) in U_p . (Defaults are $U_{min}=.0001$, $\Delta U=1.1$. The code tests on PMX so if U_{max} is not input, it defaults to $PMX=50$ kb.)

NP[2]=4: Because the shock data appear to be consistent with a piecewise linear U_s-U_p relationship, many experimenters have generated such fits and several EOS models use these U_s-U_p fits to obtain the Hugoniot. CRT has built a data base of the fits that can be used to generate data sets for comparison with other models or data. Setting NP[2]=4 will cause EQN to search the U_s-U_p data base for the fit corresponding to an ID number (ENUM=SETUP[1]), Author (IAUT=SETUP[2]) and initial density (RHOO=SETUP[3]). After finding the coefficients of the U_s-U_p fit requested, EQN generates the complete Hugoniot data set as above.

4.2.3 EXPHUG.

For ROUT=EXP, subroutine EXPHUG is selected to process experimental Hugoniot and release data from the DNA EOS data base. Input to EXPHUG is summarized as follows;

NP

- 1 LINE Reference number of data for plotting or other routines
- 2 LEX if $\neq 0$; generate a subset of data from a previous data set denoted by NP(1)
- 3 iHEL if = 0; ignore Hugoniot Elastic Limit (HEL) input
1; use HEL input where available for each author
2; use HEL input for ALL subsequent data

SETUP

- 1 EDIT1 Number of experimental Hugoniot data set
if EDIT1 > 100, data on Unit 10 (Rocks,grout,H₂O)
if " < 100, data on Unit 11 (Metals, elements)
- 2 RHOMN Minimum initial ρ to be included in data set {0.}
- 3 RHOMX Maximum initial ρ to be included in data set {100.}

For NP[2]=0 HUGEXP reads data from the files containing the shock and release data bases and calculates the complete set of Hugoniot parameters, i.e., P, ρ , U_s , U_p , and E. The routine searches the appropriate data base corresponding to the material number EDIT1 {SETUP[1]}. Only points with initial densities between input limits RHOMN and RHOMX (SETUP[2 and 3]) are stored for future plotting. If the limits are not specified, all the data for the selected material are included.

The principal Hugoniot for most materials is not a single shock wave over the entire range of pressures of interest. The stress at which the material can no longer support the elastic deviators, solid-solid or solid-fluid phase changes and other dynamic processes (e.g., pore collapse) may cause a decomposition of the Hugoniot into several waves, a precursor whose pressure is referred to as the Hugoniot elastic limit (HEL) and the main shock³. Since the precursor may be due to a phase change or other process, HEL may be a misnomer, however, it is used to describe the precursor stress regardless of its cause. The precursor is distinguished by the fact that it travels

³ It is even possible to decompose a shock into more than 2 waves. The waveforms in the marble in the DISTANT MOUNTAIN tests suggest a 3 wave structure. Such a wave set is not considered here.

with a wave speed, U_{sp} , that is faster than that of the main wave. If a precursor is present, the main wave is actually impinging on preshocked material and the Hugoniot jump conditions must be altered to account for the change. Where the precursor was reported, it is included in the data base.

One problem, particularly in older data obtained in less sophisticated experiments, is that the precursor may have been overlooked. In consideration of this possibility, an option is available in processing the data. If NP[3]=2 and the data base includes a line with the HEL U_{sp}, U_{pp} data, these data are used to determine if any subsequent shock points are multiple shocks ($U_s < U_{sp}$). If so, the complete Hugoniot state is calculated using the HEL data as the initial state. If NP[3]=1, only the data from the author reporting the HEL are checked and used where appropriate. If NP(3)=0, only experimental data for which the precursor was reported by the author are treated as double shocks.

If $NP[2] > 0$, EXPHUG assumes that a previous call has stored a data set for the material in line=NP[2] and this call is to generate a subset of that data limited by RHOMX and RHOMX. The $NP[2] > 0$ option is useful in that it preserves the symbol types associated with each experimenter. This provides some continuity when plotting the various data sets.

An example of the output generated by ROUT= EXP is presented in Table 4-3. The initial printout lists the authors and the Hugoniot data in the order stored in the ROCKHUG (or METHUG) database. The two letter designation at the left of each row designates the two measured variables, e.g., UP for particle velocity and pressure; SP for shock velocity and pressure.. The remainder of the line contains the complete set of data associated with the Hugonot point. If a release path for the data point is also stored in the RELAD database, a second line denoting that is printed next After culling the Hugoniot data in the database and eliminating those outside the requested density limits, the code sorts the remaining points and produces a second list of the results in order of increasing pressure.

Table 4-3. Example of the output generated by ROUT=EQN.

Part 1 -- Echo of the input from ROCKHUG

PHYLLITE TYPE ETA	P (MBAR)	Us (C/US)	Up (C/US)	RHO	V	init RHO	ENG (TE/G)	1+PV/E	IDN-	N
FURNISH (93)										
UP 1.0800	0.0523	0.5076	0.0376	2.959	0.338	2.740	7.069E-04	26.003	13-	1 SLP-1
RA	RELEASE PATH FROM FILE FOR SHOT SLP1									
UP 1.1435	0.0861	0.5004	0.0628	3.133	0.319	2.740	1.972E-03	14.935	13-	2 SLP-2
RA	RELEASE PATH FROM FILE FOR SHOT SLP2									
UP 1.2170	0.1627	0.5771	0.1029	3.335	0.300	2.740	5.294E-03	10.216	13-	3 SLP-3
RA	RELEASE PATH FROM FILE FOR SHOT SLP3									
UP 1.4015	0.2658	0.5819	0.1667	3.840	0.260	2.740	1.389E-02	5.982	13-	4 SLP-4
RA	RELEASE PATH FROM FILE FOR SHOT SLP4									
UP 1.6847	0.6571	0.7682	0.3122	4.616	0.217	2.740	4.873E-02	3.921	13-	5 SLP-7
RA	RELEASE PATH FROM FILE FOR SHOT SLP7									
UP 1.8710	1.3971	1.0466	0.4872	5.126	0.195	2.740	1.187E-01	3.296	13-	6 SLP-6
RA	RELEASE PATH FROM FILE FOR SHOT SLP6									
KT SLATE (93)										
UP 1.0091	0.0044	0.4226	0.0038	2.765	0.362	2.740	7.220E-06	0.000	14-	7 3621
UP 1.0187	0.0098	0.4416	0.0081	2.791	0.358	2.740	3.281E-05	0.000	14-	8 3616
UP 1.0332	0.0202	0.4787	0.0154	2.831	0.353	2.740	1.186E-04	61.171	14-	9 3617
UP 1.0567	0.0345	0.4843	0.0260	2.895	0.345	2.740	3.380E-04	36.252	14-	10 3618
UP 1.0798	0.0486	0.4900	0.0362	2.959	0.338	2.740	6.552E-04	26.071	14-	11 3619
UP 1.0615	0.0406	0.5057	0.0293	2.909	0.344	2.740	4.292E-04	33.520	14-	12 3622
lines missing										
FURNISH(92d) froz										
UP 1.0215	0.0133	0.4799	0.0101	2.797	0.358	2.738	5.101E-05	94.022	16-	23 PFP1A
UP 1.0347	0.0254	0.5254	0.0176	2.844	0.352	2.749	1.549E-04	58.704	16-	24 PFP2
UP 1.0540	0.0354	0.5012	0.0257	2.894	0.345	2.746	3.302E-04	38.003	16-	25 PFP3
UP 1.0829	0.0495	0.4845	0.0371	2.980	0.336	2.752	6.882E-04	25.120	16-	26 PFP4
UP 1.1150	0.0819	0.5379	0.0555	3.057	0.327	2.742	1.540E-03	18.384	16-	27 PFP5
UP 1.0378	0.0239	0.4888	0.0178	2.845	0.352	2.741	1.584E-04	53.925	16-	28 PFR1
UP 1.0736	0.0483	0.5073	0.0348	2.939	0.340	2.737	6.055E-04	28.156	16-	29 PFR2
KTECH(92) t>0										
SP 1.0119	0.0084	0.5060	0.0059	2.833	0.353	2.800	1.758E-05	0.000	17-	30 3602
SP 1.0222	0.0164	0.5200	0.0113	2.852	0.351	2.790	6.389E-05	91.002	17-	31 3586
SP 1.0370	0.0268	0.5200	0.0185	2.883	0.347	2.780	1.718E-04	55.098	17-	32 3584
SP 1.0519	0.0364	0.5140	0.0254	2.935	0.341	2.790	3.221E-04	39.500	17-	33 3585
SP 1.0729	0.0530	0.5270	0.0358	3.015	0.332	2.810	6.405E-04	28.450	17-	34 3587
lines missing										

Part 2 -- Hugoniot data arranged by increasing PH

PHYLLIT (2.72 - 2.82)

	N	IDN	ETA	P (MBAR)	Us (C/US)	Up (C/US)	RHO	V	RHOI	ENG (TE/G)	1+PV/E
1	7	14	1.0091	0.0044	0.4226	0.0038	2.765	0.362	2.740	7.220E-06	0.000
2	35	18	1.0118	0.0083	0.5050	0.0059	2.823	0.354	2.790	1.735E-05	0.000
3	30	17	1.0119	0.0084	0.5060	0.0059	2.833	0.353	2.800	1.758E-05	0.000
4	38	18	1.0119	0.0085	0.5070	0.0059	2.853	0.350	2.820	1.767E-05	0.000
5	8	14	1.0187	0.0098	0.4416	0.0081	2.791	0.358	2.740	3.281E-05	0.000
6	16	15	1.0146	0.0109	0.5283	0.0076	2.762	0.362	2.722	2.888E-05	0.000
lines missing											
37	20	15	1.1168	0.0865	0.5490	0.0574	3.066	0.326	2.745	1.647E-03	18.128
38	15	14	1.1425	0.1028	0.5485	0.0684	3.130	0.319	2.740	2.339E-03	15.038
39	3	13	1.2170	0.1627	0.5771	0.1029	3.335	0.300	2.740	5.294E-03	10.216
40	4	13	1.4015	0.2658	0.5819	0.1667	3.840	0.260	2.740	1.389E-02	5.982
41	5	13	1.6847	0.6571	0.7682	0.3122	4.616	0.217	2.740	4.873E-02	3.921
42	6	13	1.8710	1.3971	1.0466	0.4872	5.126	0.195	2.740	1.187E-01	3.296

for ROUT = EXP User LINE = 2 equal to driver Lin 2

4.2.4 FLIP - Reverse Hugoniots.

When a shock wave passes through two different materials or when one material strikes the other, it is possible to determine the shock conditions at the interface knowing only one parameter if the Hugoniots of the two media are also known. This is done by rotating one of the Hugoniots, P_H about the $U_p=0$ axis and then translating the rotated (flipped) curve, P_F so that the $P_F=0$ point remains on the x-axis. Calling FLIP provides the tools to flip and translate the Hugoniots for several types of input, namely.

NP

1	LINE	Reference number of data for plotting or other routines
2	L1	Previous line to be flipped
3	L2	Previous line to compare to L1 to obtain BCF's
8	NPP	read in additional U_p, P data for flipped Hugoniots

For $NP[3] = 0$

	0;	SETUP = up to 12 U_p 's where P_H and P_F intersect
NP[4]	= 1	" " " P's " " " " "
	2	" " 6 pairs of U_p, P that P_F 's pass through

SETUP NP[3]>0

1	P2MAX	Max pressure on L2 for BCF's [def=.25 Mb]
2	PINC	Ratio of successive pressures along L2 for BCF's

For NP[3]=0, FLIP flips the data set defined by NP[2] and translates the result to intersect with the original curve. If NP[4] = 0 or 1, the Hugoniot is translated so that P_F intersects P_H at either U_p (NP[4]=0) or P (NP[4]=1), where $U_p = \text{SETUP}[i], i=1, 12$ or $P = \text{SETUP}[i], i=1, 12$. If NP[4]=2, a set of flipped Hugoniots are generated that intersect with up to six $U_p - P$ pairs read into SETUP[1-12]. Additional pairs are again read by setting NP[8]≠0. For each line flipped, a line of text is printed given the point of rotation, thusly;

ME191 r = 1.91

FOR LINE 11 HUGONIOT IS FLIPPED ABOUT $U_p = 0.100$ (cm/us)

User line 6 copy of line 4 and flipped to make 6 new lines

For NP[3]>0, FLIP will generate the borehole correction factors relating one medium to another. The BCF is defined as the ratio of the U_p or P in the second

material to the corresponding value in the first. The shock is assumed to go from the data set defined by L1 {NP[2]} into the one defined by L2 {NP[3]}. If the impedance ($I = \rho_0 U_s^2$) of both media are identical, the BCFs are 1.0. If the impedance is less in the second medium [$I_2 < I_1$], the BCF_U is greater than 1.0 and the BCF_P is less than 1.0. If the second medium has a higher impedance [$I_2 > I_1$], the BCF_U is less than 1.0 and the BCF_P is greater than 1.0.

FLIP finds the BCF's starting at $PTST=1$ kbar and increasing the pressure by 10% each step. $PTST$ and the corresponding U on the second Hugoniot are one pair of data. The Hugoniot of the first medium is translated until it intersects the second at $PTST$ and the pressure and particle velocity at its intersection with the original first medium's Hugoniot are the other two values needed to determine the ratios. A printout for each $PTST$ is generated with the two pressures and BCF_P and the two velocities with BCF_U up to a maximum $PTST$ of $P2MAX$ [def=250 kbars], Table 4-4.

Table 4-4. Example of FLIP printout for borehole correction factors.

BOREHOLE CORRECTION FACTORS between ME191 and HTH3							
N1	N2	Pff	Pbh	bcfP	Uff	Ubh	bcfUp
44	31	0.0009	0.0010	0.8415	0.0033	0.0029	1.1569
45	33	0.0010	0.0012	0.8503	0.0037	0.0033	1.1483
46	34	0.0011	0.0013	0.8535	0.0040	0.0035	1.1441
47	35	0.0012	0.0014	0.8567	0.0042	0.0037	1.1401
48	36	0.0013	0.0015	0.8598	0.0045	0.0040	1.1362
50	38	0.0014	0.0017	0.8625	0.0049	0.0044	1.1308
51	39	0.0015	0.0018	0.8638	0.0052	0.0046	1.1281
84	70	0.0180	0.0204	0.8827	0.0354	0.0321	1.1060
92	79	0.0362	0.0401	0.9038	0.0593	0.0549	1.0816
122	110	0.1538	0.1599	0.9618	0.1639	0.1595	1.0274
124	112	0.1679	0.1737	0.9668	0.1740	0.1700	1.0235
127	115	0.1885	0.1934	0.9743	0.1884	0.1848	1.0196
130	117	0.2049	0.2100	0.9755	0.2003	0.1967	1.0183
132	119	0.2244	0.2296	0.9773	0.2139	0.2103	1.0168

4.2.5 HUG - The Hugoniot Driver.

For ROUT=HUG , subroutine HUG is selected to generate the principal Hugoniot⁴ for the material specified. Input to HUG is limited to several optional parameters, namely for ROUT = HUG

NP

1 LINE Reference number of data for plotting or other routines

SETUP

- 1 PUP Max stress to load Hugoniot; {100Mb}⁵
- 2 YVEL Initial velocity (volume) step size; {dv = 0.001 cm/ μ s}
- 3 GSY Initial Hydrostatic pressure {0 Mb}

HUG begins by calling EQSINIT to generate a unit cell compatible with the CRALE2 code subroutines. Using the CRALE routines insures consistency between the results of the driver and the 2D code calculations. The Hugoniot is found by setting the vertical velocities at the top of this cell to a negative value thus generating a uniaxial compressive strain condition. (Defaults of $\Delta t=1$ and YVEL=.001, result in an initial 0.1% change in volume. The time step is just used to generate displacements and does not imply a strain rate!) The data generated by HUG are tagged with a number between 1 and 99, NP(1), so that they can be retrieved for use in plots or other routines, e.g., EQN and FLIP.

To obtain the complete Hugoniot, HUG runs through a series of steps for continually increasing compressions. Each step begins by adjusting YVEL so that the next Hugoniot stress, σ_y , is at least 1.05 but less than 1.25 times the previous. YVEL may also be adjusted if the code had trouble converging on the last answer. HUG converges on the Hugoniot stress by fixing the change in strain, ϵ_y , and iterating on the change in the cell's specific energy until it differs by less than 0.01% from the energy density in a strong shock as determined by the Hugoniot jump condition, i.e.,

$$E_H = .5\sigma_y d\epsilon_y \quad (4.2)$$

⁴ The principal Hugoniot is the locus of shock states for a material whose pre-shock state is $P=0$, $U_p=0$, $E=E_0$, and $\rho=\rho_0$.

⁵ {} indicates default value

where E_H is the energy/gram; σ_y , the axial (vertical) stress; and ϵ_y , the axial strain. Since the motions are uniaxial; $\epsilon_x = \epsilon_z = \epsilon_{xy} = 0$, so the compression and axial strain are related by

$$\mu = -\epsilon_y / (1 - \epsilon_y) \quad (4.3)$$

and Equation 4.1 is equivalent to the more familiar but less general

$$E_H = .5P\Delta V \quad (4.4)$$

for a hydrodynamic material. Having converged on the Hugoniot pressure and energy for the current strain, ϵ_y , HUG stores and prints the shock state parameters of interest (μ , σ , P_H , K , G , U_s , U_p , etc.) plus the pressure corresponding to μ and $E=E_0$, i.e., the zero-energy hydrostat. The routine proceeds to the next strain until the Hugoniot stress exceeds PUP [default = 100 Mb, can be set by SETUP(2)].

Upon convergence at each step, HUG checks that the shock velocity, U_s , is still a maximum. If U_s is less than that attained at a lower stress, the shock will not propagate as a single wave, but breaks into a precursor, traveling at the previous higher velocity and a second front moving with a lower speed. The Hugoniot equations for such a double shock are slightly more complex since the initial conditions for the second pulse is the state (i.e., P , ρ , U_p , E) of the material behind the precursor. When HUG finds such a condition, the routine saves the data at the first front, i.e., the Hugoniot Elastic Limit (HEL) and Equation 4.2 is modified appropriately. Note, the drop in wave speed could result from a phase change, void collapse or other non-elastic process as well as the onset of plastic yielding, so the term HEL may be a misnomer for some materials. Nonetheless HEL is used to label the initial point of the double shock region regardless of the cause. HUG continues to compare the current shock velocity, U_s , against the maximum and when U_s equals or exceeds the previous high, the shock is again assumed to merge into a single wave starting from the original state of the material. While even more complex shock states are possible, HUG only considers at most a two-wave structure.

If the EOS being exercised is very sensitive to changes in energy, it is possible for the Hugoniot to reach a maximum compression or even double-back in P-V or P- μ space. Gases and highly hysteretic solids such as snow exhibit this behavior. In this case the test compression may not be attainable in a single shock and the standard

(energy) iteration can not converge. When HUG cannot converge within 30 iterations or if the energy changes from the last step by more than a factor of 2, the code proceeds by guessing a change in E and iterates on density for an additional 20 tries. If it still cannot converge, the last five steps are printed out and the code continues. HUG assumes the material is passing through some unique local phase. While the routine may not be able to converge in a small range of densities due to local phenomena, usually it will converge again at higher densities and energies.

After each step, HUG automatically generates a one line printout. Output from a typical run is shown at the end of this subsection. The printout for each step includes as much information about the state of the material as can be squeezed onto a single 132 character line, beginning with ρ , μ , the pressure at $E=E_0$, P_H , σ_y and the strain, ϵ_y . The printout also includes the various wave speeds [shock (U_s), local compressional or sound (C_p), and shear (C_s)], the bulk (K) and shear (G) moduli, Poisson's ratio (ν), the ratio of $\sqrt{\sigma}/Y$ (DSIG), the yield surface (Y), the plastic strain (EPL, ϵ_{pl}) and Hugoniot energy, E_H . When a material melts (i.e., $E \geq ES$), G, Y and ϵ_{pl} are set to zero and an effective gamma (GAM), defined as

$$\gamma = 1. + P / \rho E \quad (4.5)$$

and the specific energy density (E_H) are printed instead of ν and ϵ_{pl} .

DMM001

12/0

HUGONIOT / MEAN STRESS for EOS with NE = 1 DMM001 initial RHO = 2.7100 RHOREF = 2.7100

n	RHO	mu	P(E=0)	P(HUG)	SIGY	-mu/eta	Up	Us	Cp	Cs	K	G	NU/GAM	DSIG	Y	Eng/Epl	IT
----- (MBAR) ----- CM/US -----*----- MBARS -----																	
1	2.710	0.000000	0.00E+00	3.000E-20	3.000E-20	0.000E+00	0.0000	0.0000	0.534	0.275	0.5000	0.2045	0.320	0.00	0.00E+00	0.000E+00	0
2	2.710	0.000003	1.68E-06	1.683E-06	2.573E-06	-3.264E-06	0.0000	0.5393	0.534	0.515	0.5000	0.2045	0.320	0.00	3.02E-04	1.549E-12	2
77	2.740	0.011048	5.64E-03	5.670E-03	8.750E-03	1.093E-02	0.0059	0.5436	0.546	0.525	0.5242	0.2130	0.321	0.95	3.25E-03	1.790E-05	4
78	2.742	0.011917	6.10E-03	6.128E-03	9.456E-03	1.178E-02	0.0064	0.5443	0.547	0.527	0.5260	0.2137	0.321	1.01	3.30E-03	2.085E-05	4
79	2.745	0.012855	6.59E-03	6.624E-03	1.022E-02	1.269E-02	0.0069	0.5451	0.548	0.529	0.5280	0.2143	0.321	1.08	3.34E-03	2.411E-05	5
80	2.748	0.013841	7.10E-03	7.148E-03	1.103E-02	1.365E-02	0.0075	0.5459	0.549	0.531	0.5300	0.2150	0.321	1.15	3.37E-03	2.797E-05	5

The HUGONIOT ELASTIC LIMIT is 1.10266E-02

81	2.750	0.014878	7.65E-03	7.696E-03	1.162E-02	1.466E-02	0.0079	0.4666	0.550	0.528	0.5322	0.2158	0.321	1.15	3.40E-03	3.056E-05	8
82	2.753	0.015970	8.23E-03	8.287E-03	1.224E-02	1.572E-02	0.0084	0.4657	0.551	0.541	0.5344	0.2165	0.322	1.15	3.42E-03	3.722E-05	4
83	2.756	0.017148	8.85E-03	8.920E-03	1.289E-02	1.686E-02	0.0089	0.4642	0.552	0.538	0.5368	0.2173	0.322	1.15	3.44E-03	4.240E-05	5
84	2.760	0.018387	9.51E-03	9.590E-03	1.358E-02	1.806E-02	0.0095	0.4634	0.553	0.540	0.5393	0.2181	0.322	1.15	3.45E-03	4.827E-05	5
85	2.763	0.019692	9.72E-03	9.808E-03	1.380E-02	1.931E-02	0.0099	0.4268	0.554	0.167	0.5410	0.2187	0.322	1.15	3.46E-03	5.425E-05	5
85	2.767	0.021066	9.91E-03	1.001E-02	1.401E-02	2.063E-02	0.0102	0.3990	0.555	0.158	0.5428	0.2194	0.322	1.15	3.46E-03	6.059E-05	5
129	3.291	0.214335	1.14E-01	1.265E-01	1.301E-01	1.765E-01	0.0920	0.5198	0.752	1.087	1.0605	0.3533	0.350	1.15	3.12E-03	4.298E-03	8
130	3.305	0.219398	1.19E-01	1.321E-01	1.356E-01	1.799E-01	0.0949	0.5262	0.755	1.104	1.0720	0.3534	0.351	1.15	3.10E-03	4.560E-03	8
131	3.319	0.224759	1.24E-01	1.381E-01	1.416E-01	1.835E-01	0.0979	0.5328	0.757	1.121	1.0839	0.3533	0.353	1.15	3.07E-03	4.848E-03	8
132	3.334	0.230440	1.29E-01	1.445E-01	1.481E-01	1.873E-01	0.1012	0.5397	0.760	1.138	1.0959	0.3527	0.355	1.15	3.04E-03	5.164E-03	8

Single SHOCK WAVE again for stresses above 1.54986E-01

133	3.351	0.236462	1.35E-01	1.515E-01	1.550E-01	1.912E-01	0.1046	0.5469	0.763	1.156	1.1083	0.3518	0.356	1.15	3.01E-03	5.511E-03	8
134	3.368	0.242848	1.41E-01	1.590E-01	1.625E-01	1.954E-01	0.1082	0.5539	0.766	1.178	1.1209	0.3504	0.358	1.15	2.98E-03	5.903E-03	9
135	3.386	0.249625	1.48E-01	1.671E-01	1.705E-01	1.998E-01	0.1121	0.5613	0.768	1.197	1.1337	0.3485	0.361	1.15	2.94E-03	6.336E-03	9
189	5.780	1.132963	1.11E+00	3.429E+00	3.429E+00	5.312E-01	0.8198	1.5434	1.239	0.000	4.1584	2.7599	0.500	0.00	6.77E-05	3.371E-01	9
189	5.871	1.166522	1.15E+00	3.691E+00	3.691E+00	5.384E-01	0.8563	1.5904	1.266	0.000	4.3421	2.7110	0.500	0.00	6.77E-05	3.674E-01	9
190	5.970	1.202914	1.19E+00	3.990E+00	3.990E+00	5.461E-01	0.8967	1.6421	1.295	0.000	4.5457	2.6610	0.500	0.00	6.77E-05	4.024E-01	9
190	6.077	1.242465	1.23E+00	4.339E+00	4.339E+00	5.541E-01	0.9419	1.7000	1.328	0.000	4.7765	2.6097	0.500	0.00	6.77E-05	4.436E-01	6

Hugoniot solid phase change, rhoE, rEo 3.053E+00 2.760E+00

191	6.194	1.285551	1.28E+00	4.749E+00	4.749E+00	5.625E-01	0.9928	1.7652	1.364	0.000	5.0410	2.5558	0.500	0.00	6.77E-05	4.929E-01	9
191	6.321	1.332610	1.33E+00	5.237E+00	5.237E+00	5.713E-01	1.0507	1.8392	1.405	0.000	5.3483	2.5008	0.500	0.00	6.77E-05	5.520E-01	9
192	6.461	1.384154	1.39E+00	5.805E+00	5.805E+00	5.806E-01	1.1151	1.9208	1.450	0.000	5.6949	2.4449	0.500	0.00	6.77E-05	6.218E-01	9
204	9.985	2.684676	2.82E+00	5.902E+01	5.902E+01	7.286E-01	3.9836	5.4674	3.241	0.00028	4.621	1.7685	0.500	0.00	6.77E-05	7.691E+00	10
20510	4.23	8.45946	2.99E+00	7.562E+01	7.562E+01	7.400E-01	4.5440	6.1406	3.557	0.00034	2.857	1.7291	0.500	0.00	6.77E-05	9.951E+00	10
20610	7.76	2.976478	3.14E+00	9.607E+01	9.607E+01	7.485E-01	5.1512	6.8819	3.907	0.00041	3.577	1.6964	0.500	0.00	6.77E-05	1.280E+01	10
20711	0.58	3.080343	3.25E+00	1.196E+02	1.196E+02	7.549E-01	5.7727	7.6467	4.268	0.00049	3.656	1.6701	0.500	0.00	6.77E-05	1.614E+01	10

for ROUT = HUG User LINE = 3 equal to driver Lin 1

CPU TIME USED 2.46815

4.2.6 REL -- Release Adiabats from the Hugoniot.

After a call to HUG has produced a Hugoniot, setting ROUT = REL will call subroutine REL to generate the paths (release adiabats) followed during unloading. The input to REL are summarized as follows;

NP

- 1 -- not used by REL
- 2 = 0 - generate release adiabats from preceding Hugoniot
NOTE: If NP[2]=0, REL must immediately follow the call to HUG for the material of interest
 - 1 - calculate P and release path from input μ and E
 - 2 - calculate P from input μ , E. No release path.
 - 3 - find the lowest Hugoniot pressure that unloads to 1 bar, i.e., the liquid side of the steam dome. (Subroutine VAP)
- for **NP[2] = 0**
- 3 = 0 - Iterate on energy and pressure
 - 1 - use E from previous step like the CRALE codes
- 4 = 0 find closest point along Hugoniot for release
 - 1 - interpolate along Hugoniot to release from exact values of σ 's

SETUP

for **NP[2] = 0**

- 1 PTOP Max P {Mb} for plot of Hugoniot and adiabats
- 2-6 PSAV_i if PSAV[2] = 0; generate 5 adiabats, incrementing by 0.2(PTOP) or 0.2(ETT); where ETT is the value of μ at PTOP
if PSAV[2] \neq 0; generate adiabats starting at each PSAV[2-6] \neq 0.

for **NP[2] = 1 or 2**

- 1 EMUL value of μ ; use μ , E to calculate P
if material is an HE and SETUP(1)=-1 calculate CJ point
- 2 ENG value of E
- 3 constant σ' added to P for release paths

for **NP[2] = 3**

- 1 ENG minimum value of E for vapor, {Es(NE)}
- 2 CTE optional coefficient of thermal expansion

For $NP[2] = 0$, REL will generate release adiabats from selected pressures along the Hugoniot produced by the last call to HUG. If $SETUP[2]=0.$, $SETUP[1]$ is assumed to be the peak stress, P_{TOP}, and unload paths are generated for 5 stresses set to 20, 40, 60, 80 and 100% of P_{TOP}. If $SETUP[2] \neq 0.$, release paths are generated starting at stresses on the Hugoniot corresponding to each value of $SETUP[2]$ through [6]. Repeating the line $ROUT=REL$ and $NP[2]=0$ allows the user to generate as many release paths as are needed.

For each requested release stress, REL finds the data point on the Hugoniot that equals or exceeds it and calls subroutine RELSET to establish the proper initial conditions. (If $NP[4] \neq 0$, RELSET interpolates in the Hugoniot data to start at the exact stress requested.) Like HUG, REL also iterates on the energy density each step to converge on the appropriate point in P-V-E space. First, the top of the cell is allowed to move up decompressing the cell in uniaxial strain. The pressure is calculated and the energy is then updated,

$$E_n = E_{n-1} + .5(\sigma_n + \sigma_{n-1})d\varepsilon_y \quad (4.6)$$

where the n-1,n subscripts indicate successive steps. The EOS is then called again with the updated energy, and E_n is recomputed until it does not change. As an option, if $NP[3]$ is set to 1, REL skips the iteration and generates the path exactly as would CRALE1 and CRALE2, i.e., using ε_n and E_{n-1} . REL continues along the release adiabat until either σ_y drops below PMN {1 bar} or μ is less than EMUMIN {-.95}.

The printed output from REL begins with a listing of the data for the point on the Hugoniot at which it starts. REL generates a line-by-line edit of the unloading path similar to that produced by HUG. At the end of the path, the initial, final and change in energy densities are printed.

$ROUT=REL$ allows several special options In addition to the standard release paths from the Hugoniots, chosen by setting $NP[2]>0$. For $NP[2]=1$, REL will produce the unload adiabat from an arbitrary input point μ , E set by $SETUP[1]$ and [2] respectively. REL calls EQST for P and adds σ' ($SETUP[3]$) to get the initial σ_y and proceeds to generate the release adiabat as for $NP[2]=0$ above.

Setting NP[2]=2, REL will calculate the P for the μ , E input pair as above but will skip the release path. This option is used primarily to obtain single point comparisons with other models or data.

For NP[2]=3, REL calls VAP. This routine starts by finding the smallest density that returns a 1 bar pressure for an energy density equal to E_m (the Pv cutoff). This is, presumably, a point on the liquid side of the steam dome. It then backs up the adiabat, by increasing μ and finding a P and E that satisfy $\Delta E = P\Delta V$, until it reaches a point that also satisfies the Hugoniot jump condition, $E = .5P(V - V_0)$, where V_0 is the usual initial specific volume, $1/\rho_0$. VAP then finds 4 additional release paths by reducing the 1 bar μ by 20% decrements, and increasing the E to find another 1 bar pressure and then generating the new adiabat. Currently these data are only printed out, a data set suitable for plotting is not available.

RELEASE ADIABAT for EQS 4 HTH3

from SIGY= 2.538E-02 mu = 1.297E-01 E = 7.150E-04 K = 3.338E-01 Up,Us = 3.817E-02 3.325E-01

J	RHO	mu	SIGY	P	ENG	MUmax	GAMMA	K	G	CP	Up	DS/YLD	MU	PLAS	CONV	ENT	IFLAG
			---- (MBAR)	-----	-----			---- MBARS	----	--- Km/S	----						
1	2.259	1.297E-01	2.538E-02	2.513E-02	7.150E-04	0.00016	5.595	0.3338	0.1234	8.2385	0.3817	0.000	0.000	0.000	0.000	4	
2	2.259	1.294E-01	2.524E-02	2.503E-02	7.126E-04	0.13016	5.496	0.3333	0.1232	4.9878	0.3829	0.840	0.000	1.000	0.000	4	
3	2.258	1.290E-01	2.501E-02	2.489E-02	7.078E-04	0.13016	5.711	0.3325	0.1229	4.9817	0.3850	0.520	0.000	1.000	0.000	4	
4	2.256	1.282E-01	2.468E-02	2.467E-02	7.008E-04	0.13016	6.026	0.3312	0.1225	4.9725	0.3881	0.040	0.000	1.001	0.000	4	
5	2.255	1.273E-01	2.424E-02	2.439E-02	6.915E-04	0.13016	6.430	0.3295	0.1219	4.9602	0.3923	-0.599	0.000	1.001	0.000	4	
6	2.252	1.261E-01	2.379E-02	2.403E-02	6.807E-04	0.13016	6.913	0.3274	0.1212	4.9447	0.3971	-1.000	0.000	1.001	0.000	4	
7	2.249	1.246E-01	2.336E-02	2.361E-02	6.665E-04	0.13016	7.474	0.3249	0.1203	4.9259	0.4023	-1.000	0.000	1.001	0.000	4	
8	2.246	1.229E-01	2.287E-02	2.311E-02	6.509E-04	0.13016	8.110	0.3219	0.1193	4.9037	0.4083	-1.000	0.000	1.002	0.000	4	
9	2.242	1.209E-01	2.230E-02	2.255E-02	6.333E-04	0.13016	8.810	0.3184	0.1181	4.8780	0.4151	-1.000	0.000	1.002	0.000	4	
10	2.237	1.187E-01	2.167E-02	2.191E-02	6.138E-04	0.13016	9.560	0.3145	0.1167	4.8485	0.4229	-1.000	0.000	1.002	0.000	4	
11	2.232	1.162E-01	2.096E-02	2.121E-02	5.925E-04	0.13017	1.037	0.3101	0.1152	4.8151	0.4316	-1.000	0.000	1.002	0.000	4	
12	2.227	1.137E-01	2.026E-02	2.051E-02	5.716E-04	0.13017	1.049	0.3056	0.1136	4.7809	0.4403	-1.000	0.000	1.002	0.000	4	
13	2.222	1.112E-01	1.956E-02	1.981E-02	5.512E-04	0.13017	1.683	0.3011	0.1121	4.7459	0.4491	-1.000	0.000	1.002	0.000	4	
14	2.217	1.086E-01	1.886E-02	1.911E-02	5.312E-04	0.13017	2.229	0.2964	0.1104	4.7101	0.4579	-1.000	0.000	1.002	0.000	4	
15	2.212	1.060E-01	1.816E-02	1.841E-02	5.116E-04	0.13017	2.671	0.2918	0.1088	4.6734	0.4668	-1.000	0.000	1.002	0.000	4	
16	2.207	1.034E-01	1.747E-02	1.771E-02	4.924E-04	0.13017	2.995	0.2870	0.1071	4.6358	0.4757	-1.000	0.000	1.002	0.000	4	
17	2.201	1.007E-01	1.677E-02	1.702E-02	4.737E-04	0.13017	3.182	0.2821	0.1054	4.5971	0.4847	-1.000	0.000	1.002	0.000	4	
18	2.196	9.800E-02	1.608E-02	1.632E-02	4.554E-04	0.13017	3.212	0.2772	0.1037	4.5574	0.4937	-1.000	0.000	1.002	0.000	4	
19	2.191	9.528E-02	1.533E-02	1.558E-02	4.376E-04	0.13017	2.478	0.2718	0.1018	4.5141	0.5028	-1.000	0.000	1.001	0.000	4	
20	2.185	9.251E-02	1.459E-02	1.483E-02	4.203E-04	0.13017	1.493	0.2664	0.0998	4.4694	0.5120	-1.000	0.000	1.001	0.000	4	
21	2.179	8.970E-02	1.385E-02	1.409E-02	4.035E-04	0.13017	0.229	0.2608	0.0978	4.4232	0.5213	-1.000	0.000	1.001	0.000	4	
22	2.174	8.685E-02	1.311E-02	1.336E-02	3.873E-04	0.13016	8.651	0.2552	0.0958	4.3754	0.5306	-1.000	0.000	1.001	0.000	4	
23	2.168	8.395E-02	1.238E-02	1.262E-02	3.716E-04	0.13016	6.720	0.2493	0.0937	4.3259	0.5400	-1.000	0.000	1.001	0.000	4	
24	2.162	8.099E-02	1.166E-02	1.190E-02	3.564E-04	0.13016	4.395	0.2434	0.0916	4.2745	0.5495	-1.000	0.000	1.001	0.000	4	
25	2.156	7.799E-02	1.094E-02	1.118E-02	3.418E-04	0.13016	1.630	0.2372	0.0893	4.2211	0.5591	-1.000	0.000	1.001	0.000	4	
26	2.150	7.492E-02	1.022E-02	1.046E-02	3.278E-04	0.13015	8.375	0.2309	0.0871	4.1654	0.5688	-1.000	0.000	1.001	0.000	4	
27	2.144	7.178E-02	9.505E-03	9.744E-03	3.144E-04	0.13015	4.576	0.2245	0.0847	4.1073	0.5786	-1.000	0.000	1.001	0.000	4	
28	2.137	6.858E-02	8.797E-03	9.035E-03	3.016E-04	0.13015	0.178	0.2178	0.0823	4.0464	0.5885	-1.000	0.000	1.001	0.000	4	
29	2.131	6.529E-02	8.093E-03	8.332E-03	2.894E-04	0.13014	5.121	0.2109	0.0797	3.9825	0.5985	-1.000	0.000	1.001	0.000	4	
30	2.124	6.192E-02	7.395E-03	7.633E-03	2.779E-04	0.13013	9.345	0.2038	0.0771	3.9152	0.6086	-1.000	0.000	1.001	0.000	4	
31	2.117	5.845E-02	6.703E-03	6.940E-03	2.670E-04	0.13013	2.790	0.1964	0.0744	3.8442	0.6189	-1.000	0.000	1.001	0.000	4	
32	2.110	5.488E-02	6.016E-03	6.252E-03	2.568E-04	0.13012	5.400	0.1887	0.0715	3.7688	0.6294	-1.000	0.000	1.001	0.000	4	
33	2.102	5.119E-02	5.335E-03	5.571E-03	2.474E-04	0.13011	7.124	0.1807	0.0686	3.6884	0.6400	-1.000	0.000	1.001	0.000	4	
34	2.095	4.736E-02	4.660E-03	4.895E-03	2.387E-04	0.13010	7.922	0.1723	0.0654	3.6022	0.6508	-1.000	0.000	1.001	0.000	4	
35	2.087	4.337E-02	3.992E-03	4.227E-03	2.308E-04	0.130	9.7770	0.1634	0.0622	3.5092	0.6618	-1.000	0.000	1.001	0.000	4	
36	2.078	3.928E-02	3.331E-03	3.565E-03	2.237E-04	0.130	8.6667	0.1541	0.0587	3.4081	0.6730	-1.000	0.000	1.001	0.000	4	
37	2.070	3.482E-02	2.678E-03	2.911E-03	2.176E-04	0.130	7.4644	0.1442	0.0549	3.2970	0.6845	-1.000	0.000	1.001	0.000	4	
38	2.060	3.017E-02	2.033E-03	2.266E-03	2.125E-04	0.130	6.1773	0.1335	0.0509	3.1733	0.6964	-1.000	0.000	1.001	0.000	4	
39	2.050	2.520E-02	1.399E-03	1.632E-03	2.084E-04	0.130	4.8179	0.1220	0.0466	3.0336	0.7086	-1.000	0.000	1.001	0.000	4	
40	2.040	1.981E-02	7.773E-04	1.009E-03	2.056E-04	0.130	3.4057	0.1093	0.0418	2.8719	0.7212	-1.000	0.000	1.001	0.000	4	
41	2.028	1.387E-02	1.706E-04	4.016E-04	2.043E-04	0.130	1.9696	0.0950	0.0364	2.6788	0.7344	-1.000	0.000	1.001	0.000	4	
42	2.014	7.119E-03	0.000E+00	0.000E+00	2.040E-04	0.130	1.0000	0.0842	0.0322	2.5209	0.7419	0.000	0.000	1.001	0.000	504	

ENERGY LOSS - initial,final,ratio 7.149566E-04 2.039692E-04 2.852889E-01

4.2.7 PATH - Special Paths.

The PATH subroutine has not been updated for this version of EQS. Both the routine and this manual will be brought into conformity with the rest of the program in a future release. The following is copied from a previous Users manual.

In addition to Hugoniot and release paths, subroutine PATH may be used by EQS to generate almost any arbitrary paths in stress-strain space, including those used in the standard uniaxial strain, hydrostat and triax (i.e., uniaxial stress) tests. PATH always produces a printout of the path followed that lists μ , P , the three principal stresses and strains, the bulk and shear moduli, yield surface, sound speed, specific energy and the EOS number. If the energy is not calculated (the default condition) the plastic strain is printed in its place. The EOS number includes the crack state as in CRALE1.

For uniaxial load-unload paths, two plots can be produced by a call to PATHPL; the first shows σ vs ϵ and P vs μ . The second plots the stress difference ($\sigma_x - \sigma_y$) vs P . For triax runs, the stress difference is plotted vs the axial strain. A simple hydro run, i.e., all three stresses equal, produces a plot with only the P vs μ curve.

The call to PATH results in reading additional data records, i.e., CARD5. Usually the path of interest requires several CARD5s to describe the full path. Frequently parts of the path are not plotted (e.g., the hydrostatic loading which precedes a triax run). Such segments of the path may be eliminated from the plot by setting the appropriate input switches.

4.2.8 PLOTN-Plotting Options.

EQS saves the data for each line generated to allow for quite general plotting. Setting ROU=PLOT will generate a single frame containing one or more data sets. The axis of the frame are determined by the first line and successive lines with ROU=PLOT are plotted on the same frame until a line with NP[8]=0 is encountered. Setting NP[8] to 0 causes PLOTN to advance the plot file so that it is ready to begin a new plot. PLOTN produces plots which can overlay common K&E plot paper. Hence, the linear axis are multiples on 1 inch, the default log scales correspond to the various scales supplied by K&E. While this provides additional ease in comparing to other data, translating the plot files to PC graphics codes such as DESIGNER allows the user to adjust the plot to fit any format. The input to PLOT is;

NP

- 1 type of plot; **MUST** be set to one of the following:
 - 2 - Hugoniot σ vs δ from HUG, where δ is set by NP(4)
 - 3 - Include Release Adiabats (REL) with Hugoniot
 - 4 - Material Parameters, K, G, ν , C_p and U_s vs σ from HUG
 - 5 - σ vs U_p , from HUG, EXP, or EQN
 - 6 - U_s vs U_p , from HUG, EXP, or EQN
 - >10 - Call PATHPL to plot output of PATH
- 2 Identifier of data set to be plotted (Def. = last calc.)
- 3-5 **see below**
- 6 LP: Line type, 0=solid line, $1 < LP < 4$ for other line types
- 7 color of data set
- 8 NPP, continuation flag: if $\neq 0$, do not advance plot frame
this allows multiple data sets on same plot
BUT: NP(8) on last data set must be 0.

for NP(1) = 2 or 3 σ vs ρ, μ, ϵ, V or V/V_0

- 3 LAX -- sets axes linear or logarithmic
 - 0 - both scales linear
 - 1 - Y (stress) scale log
 - 2 - both scales log
- 4 = LTYP - the parameter plotted on the X-axis
 - 0 plot σ_y vs density, ρ
 - 1 " " vs excess compression, μ (i.e., $\Delta V/V$)
 - 2 " " vs negative of volumetric strain, $-\epsilon$ ($-\Delta V/V_0$)
 - 3 " " vs Volume, V
 - 4 " " vs V/V_0
- 5 If data set is from **HUG** and

NP[5]>0 include plot of P (E=Eo), i.e., the hydrostat
 if data set is from **EXP** and
 NP[5]=0; plot different symbols for each experimenter and only the name
 of the material in the legend
 NP[5]<0; plot all data with one symbol (=NP[5]) and only the name
 of the material in the legend
 NP[5]=0; plot different symbols for each experimenter and list all
 references in the legend

for NP(1) = 5 or 6

- 4 if >0 plot release paths in P-Up space [NP(1)=5 only]
- 5 if ≠0; plot references for an EXP data set

SETUP

for ALL plots

1	PLXL	Length (in inches) of abscissa (X)
2	PLYL	" " " " ordinate (Y)
3	PLXMN	Minimum value (in I/O units) of X coordinate
4	PLXMX	Maximum " " " " " " "
5	PLYMN	Minimum " " " " " Y "
6	PLYMX	Maximum " " " " " " "

In general, the Hugoniot data sets that are generated by HUG or EQN are plotted as lines in PLOTN, data points from EXP are plotted by a call to PLOTH and the output of PATH are plotted by calling PATHPL. The calls to PLOTH and PATHPL are handled by PLOTN.

NP[1]=2 produces a plot of the principal Hugoniot, Figure 4-2, either the line generated by a call to HUG or EQN or the data set read from the data base by EXP depending on the value of NP[2]. The stress is always plotted in the Y direction; the X direction is one of several measures of compression, i.e., density (ρ), excess compression (μ), total strain (ϵ), volume (V) or specific volume (V/V_0) depending on NP[4]. The axes may be either linear or logarithmic depending on NP[3] and up to five line types (NP[6]) and as many as eight colors (NP[7]) are available to help differentiate the data sets. Setting **NP[1]=3** produces the same plot as NP[1]=2 but includes the release paths or data as well.

When plotting the output from HUG it is possible to include a plot of the zero energy hydrostat by setting NP[5]=1. Several options are also available when plotting the experimental data generated by EXP. In this case, if NP[5]=0, a different symbol is

used for each experimenter's data but only the name of the material is included in the legend. If NP[5]>0, each experimenter is also identified in the legend. Setting NP[5]<0 will cause all of the data for the material to be plotted with the same symbol as determined by -NP[5].

NP[1]=4 generates a plot of the bulk and shear modulus, poissons ratio, and the bulk and longitudinal wave speeds calculated by HUG as functions of the Hugoniot mean pressure, not the stress.

NP[1]=5 produces a plot of shock stress vs particle velocity, Figure 4-3. Release paths are included if NP[4]>0 and the same options on symbols and reference lists based on NP[5] as for NP[1]=2 apply. Line types and colors are also set as for NP[1]=2.

NP[1]=6 produces a plot of shock speed vs particle velocity, Figure 4-4. The same options on symbols and reference lists based on NP[5] as for NP[1]=2 apply. Line types and colors are also set as for NP[1]=2.

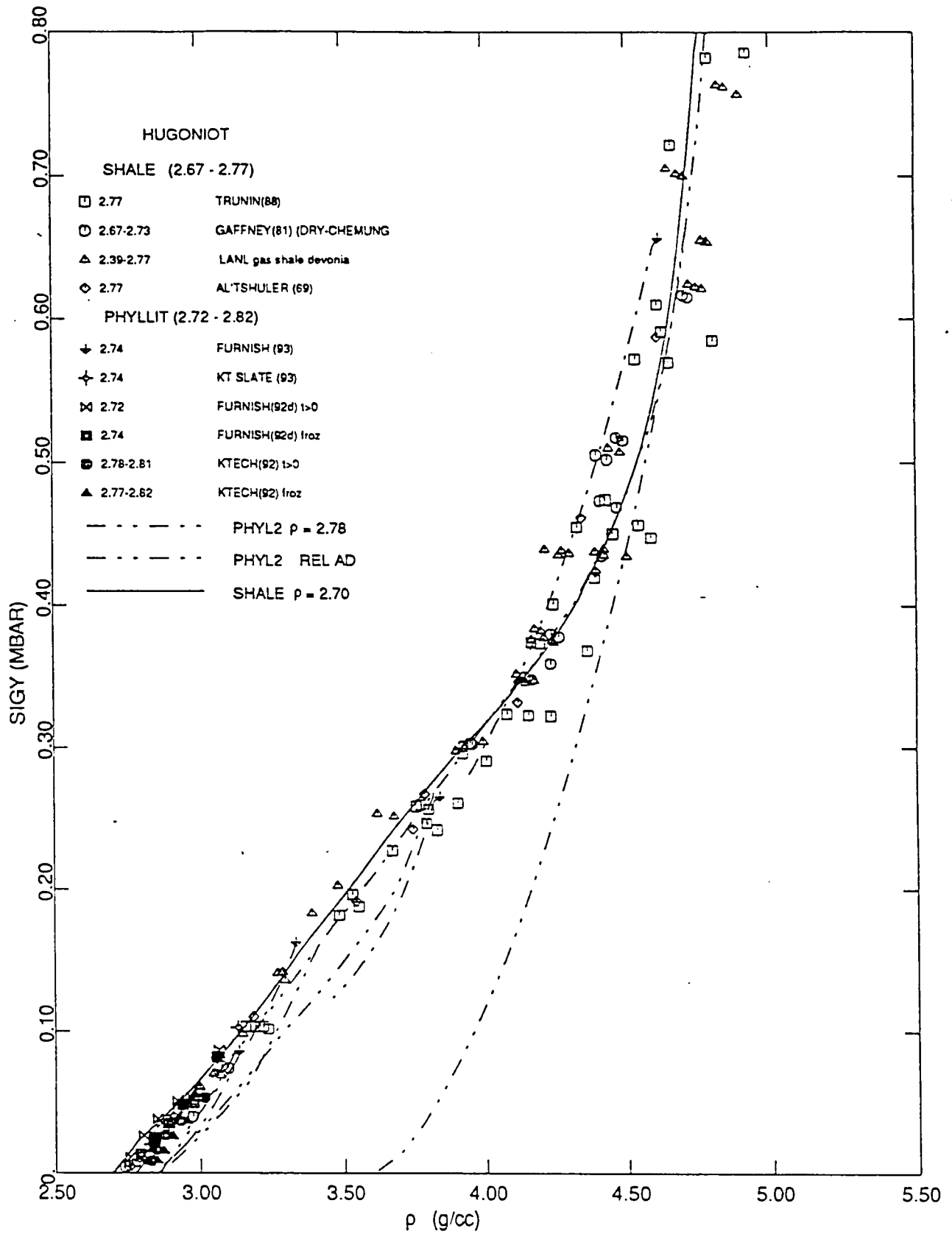

Figure 4-2. Example of plot generated by ROUT=PLOT with NP[1] = 2 or 3.

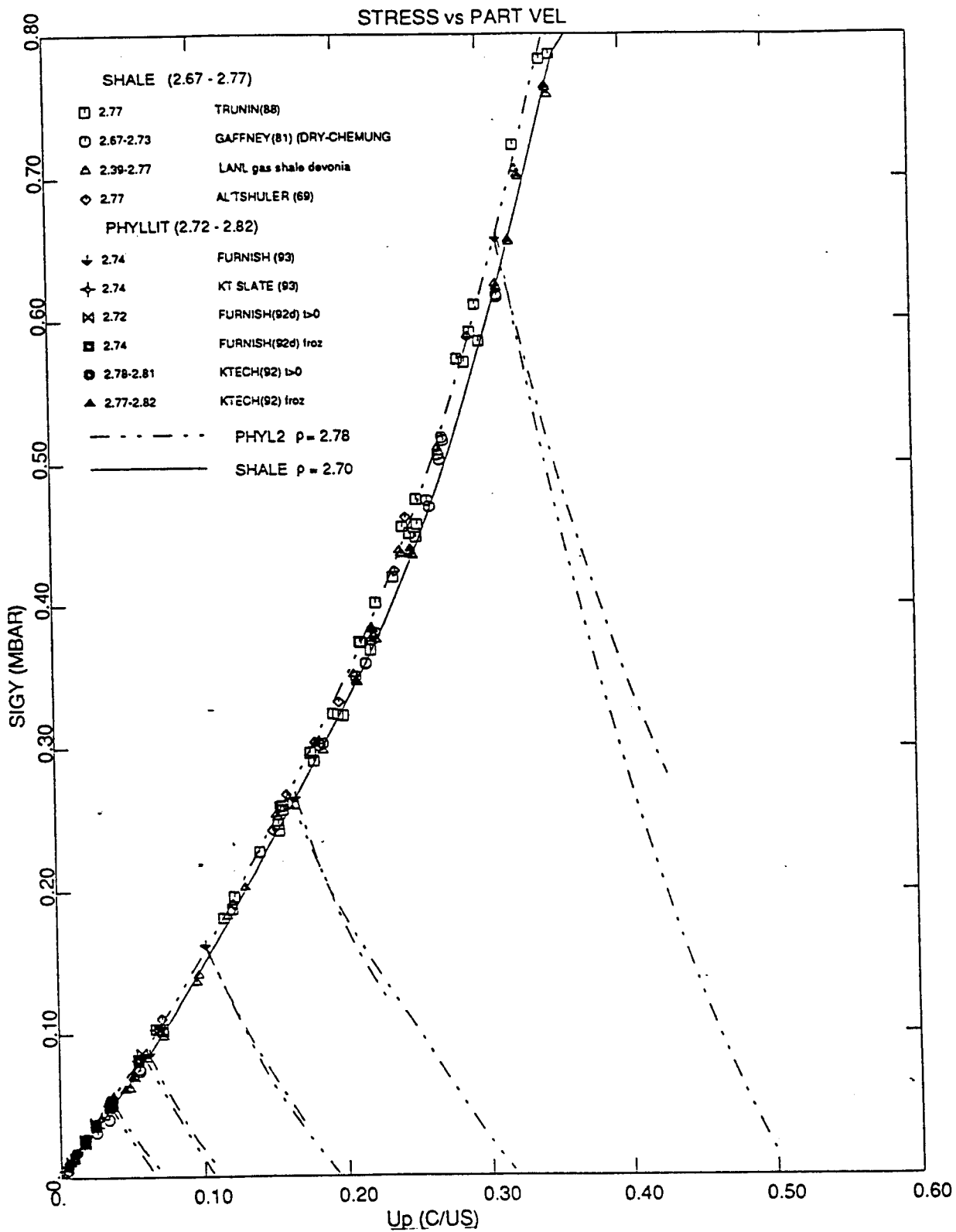

Figure 4-3. Example of plot generated by ROUT=PLOT with NP[1] = 5.

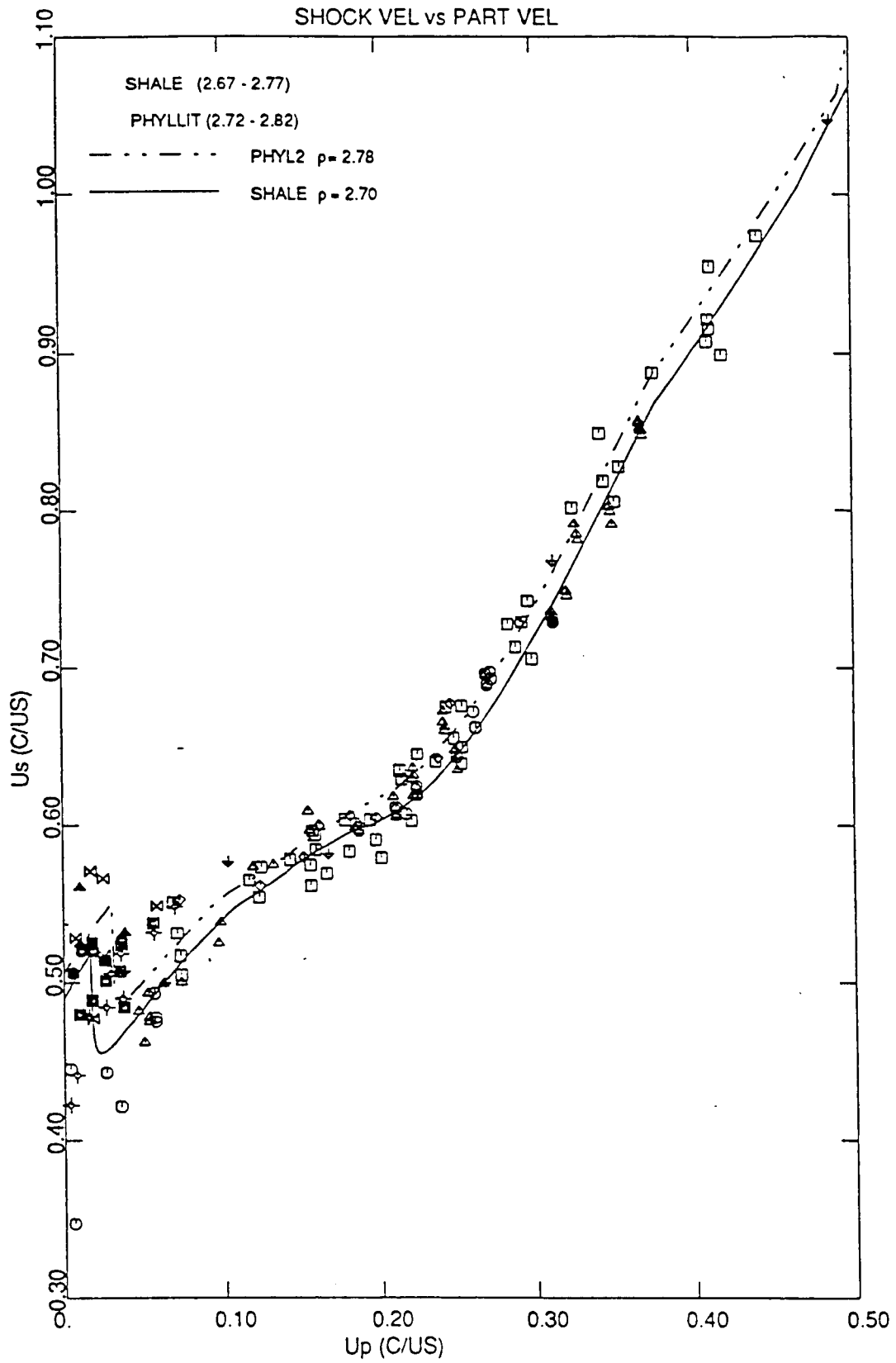

Figure 4-4. Example of plot generated by ROUT=PLOT with NP[1] = 6.

SECTION 5

DATA BASES

There are two types of data bases of interest to the DNA user community, local and archival. The local data bases are dynamic, i.e., they reside on the users' PC or network and are updated on a routine basis as new information becomes available. The current local data bases include primary experimental shock and release adiabats and material properties models. Archival data are stored in DNA directories on the LANL CFS (Common File Storage) and generally are read-only. Thus these files are useful to insure that diverse users have access to common data. Included in the archives are files relevant to both the calculational and experimental efforts conducted under the HYDROPLUS yield verification program.

5.1 HUGONIOTS.

5.1.1 Experimental Data (ROCKHUG and METHUG).

The principal Hugoniot is the locus of points obtained by subjecting a material initially at rest (σ_o , P_o and $U_p = 0.0$) to single shocks of differing magnitudes. (Secondary Hugoniot start from non-zero initial conditions.) Because a shock is an instantaneous jump from one state to another, there are a set of three equations which relate the state variables, ρ [g/cm³], σ [Mb], E [Te/g], U_s [cm/ μ s], and U_p [cm/ μ s], i.e.

$$\sigma = \rho_o U_s U_p \quad (5.1)$$

$$\rho U_p = [\rho - \rho_o] U_s \quad (5.2)$$

$$E = [U_p]^2 / 2 \quad (5.3)$$

There are three equations and five variables so that any two variables completely determine a point on the Hugoniot. Equations 5.1 - 5.3 are recast to relate the dependent Hugoniot variables to any pair in Table 5-1. The addition of one equation (or system of equations, i.e. the EOS model) reduces the number of independent variables to one. Thus, knowledge of ρ or μ , the excess compression, coupled with an EOS model is enough to determine a unique point on the Hugoniot for comparison with data. (Note: As a consequence of the jump conditions, there is an equal partitioning of the energy between internal and kinetic. As seen in Equation 5.3, E and U_p are equivalent on the Hugoniot.)

Table 5-1. Shock relationships.

GIVEN	σ	U	S	E	η	$\epsilon = \mu/\eta$
	Mbar	cm/ μ s	cm/ μ s	Tergs/g		
σ, U	--	--	$\sigma/\rho_0 U$	$U^2/2$	$[1-\rho_0 U^2/\sigma]^{-1}$	$\rho_0 U^2/\sigma$
σ, S	--	$\sigma/\rho_0 S$	--	$[\sigma/\rho_0 S]^2/2$	$[1-\sigma/\rho_0 S^2]^{-1}$	$\sigma/\rho_0 S^2$
σ, η	--	$\sqrt{\sigma\mu/\rho_0\eta}$	$\sqrt{\sigma\eta/\rho_0\mu}$	$\sigma\mu/2\rho_0\eta$	--	μ/η
σ, ϵ	--	$\sqrt{\sigma/\rho_0\epsilon}$	$\sqrt{\sigma\epsilon/\rho_0}$	$\sigma\epsilon/2\rho_0$	$1/[1-\epsilon]$	--
U, σ	--	--	$\sigma/\rho_0 U$	$U^2/2$	$[1-\rho_0 U^2/\sigma]^{-1}$	$\rho_0 U^2/\sigma$
U, S	$\rho_0 U S$	--	--		$S/[S-U]$	U/S
U, η	$\rho_0 \eta U^2/\mu$	--	$\eta U/\mu$		--	μ/η
U, ϵ	$\rho_0 U^2/\epsilon$	--	U/ϵ		$1/[1-\epsilon]$	--
S, U	$\rho_0 U S$	--	--	$U^2/2$	$S/[S-U]$	U/S
S, σ	--	$\sigma/\rho_0 S$	--	$[\sigma/\rho_0 S]^2/2$	$[1-\sigma/\rho_0 S^2]^{-1}$	$\sigma/\rho_0 S^2$
S, η	$\rho_0 S^2 \mu/\eta$	$S\mu/\eta$	--	$[S\mu/\eta]^2/2$	--	μ/η
S, ϵ	$\rho_0 S^2 \epsilon$	$S\epsilon$	--	$[S\epsilon]^2/2$	$1/[1-\epsilon]$	--
η, U	$\rho_0 \eta U^2/\mu$	--	$\eta U/\mu$	$U^2/2$	--	μ/η
η, σ	--	$\sqrt{\sigma\mu/\rho_0\eta}$	$\sqrt{\sigma\eta/\rho_0\mu}$	$\sigma\mu/2\rho_0\eta$	--	
η, S	$\rho_0 S^2 \mu/\eta$	$S\mu/\eta$	--	$[S\mu/\eta]^2/2$	--	
ϵ, U	$\rho_0 U^2/\epsilon$	--	U/ϵ	$U^2/2$	$1/[1-\epsilon]$	--
ϵ, σ	--	$\sqrt{\sigma\epsilon/\rho_0}$	$\sqrt{\sigma/\rho_0\epsilon}$	$\sigma\epsilon/2\rho_0$		--
ϵ, S	$\rho_0 S^2 \epsilon$	ϵS	--	$[\epsilon S]^2/2$		--

if $S = a + b U$; then

	σ	U	S	E	η	$\epsilon = \mu/\eta$
a, b	$\rho_0 [a + b U] U$	--	$a + b U$	$U^2/2$	$\frac{a + b U}{a + U(b - 1)}$	$\frac{U}{a + b U}$

note: $\gamma = [\eta + 1] / [\eta - 1] = [2 - \epsilon] / \epsilon$

The principal Hugoniot is very useful, since states on it can be obtained experimentally by measuring any two of the state variables. A collection of these measurements for materials of interest to DNA resides on Units 10 and 11. These data are sorted by material in sets identified by the author and report ID. (A bibliography including all the reports used in compiling the data base is contained in an ASCII file called *AUTHORS.DAT*.) All of the EOS parameters for a point on the principal Hugoniot can be derived from any pair of data or, if the material's EOS is known, by simply measuring a single state variable. Hence, each experimental Hugoniot point is stored as a line of data containing an identifier as to which two variables are stored, the initial density of the sample and the values of the two variables.

As of 1/1/94, the materials included in the Unit 10 database (rocks, etc) are listed in Table 5-2; those on Unit 11 (metals, plastics, etc) in Table 5-3. Table 5-4 contains a partial listing of the data for dry calcite and is an example of the data stored on these databases

The DNA shock database includes data stored in LLL and LANL data libraries, either referenced to the original author or by inference to the library from which it was obtained. While our primary source is the original author's report, when these are not available the data in the DNA file is simply a copy of the LLL or LANL library

5.1.2 Shock Velocity, U_s , vs Particle Velocity, U_p , Fits (*USUP.dat*, 1-1-94).

It has been observed that for many materials, over a wide range of velocities, the shock velocity increases linearly with particle velocity, i.e.;

$$U_s = C_o + sU_p \quad (5.4)$$

where C_o and s are found by least-squares fits to the data. With these two coefficients any point on the Hugoniot is determined by specifying only one variable. Because of this simplification, many experimenters and modelers use Equation 5.4 to fit data or develop material models. Some of these fits have been collected in a file, Table 5-5 and *USUP.dat*, (Unit 14), which can be accessed via EQN in the driver program (Section 4) to generate a complete Hugoniot for plotting and comparisons with other lines. Please note that Equation 5.4 should not be used when the pressure range includes phase transitions.

Table 5-2. Materials stored in the ROCKHUG.dat file (Unit 10) 11-11-93.

in order on file		in numerical order	
WATER	108.	WATER	108.
ICE	108.1	ICE	108.1
AL2O3/EPOXY(40%)	400.1	DRY ALLUVIUM	210.1
DRY ALLUVIUM	210.1	WET ALLUVIUM	210.2
WET ALLUVIUM	210.2	QUARTZ	220.
ANORTHOSITE	221.	WET QUARTZ	220.2
BASALT	260.	POROUS QUARTZ	220.3
ME GROUT	330.	FUSED QUARTZ	220.4
GROUT	330.1	ANORTHOSITE	221.
CONCRETE	330.3	GRANITE	222.
RHYOLITE	330.2	SANDSTONE	223.
GROUT	330.3	TONALITE	224.
GNEISS	370.	DRY TUFF	230.1
DRY CALCITES	240.	WET TUFF	230.2
SINGLE CRYSTAL CALCITE	240.1	DRY CALCITES	240.
WET CALCITES	240.2	SINGLE CRYSTAL CALCITE	240.1
ARAGONITE (hi-P CALCITE)	242.	WET CALCITES	240.2
MISC ROCK (RHO<3.0)	310.1	ARAGONITE (hi-P CALCITE)	242.
MISC ROCK (RHO>3.0)	310.2	BASALT	260.
MISC ROCK (RHO>4.0)	310.3	SALT	270.
PUMICE	331.	SHALE	280.
GRANITE	222.	PHYLLITE	280.1
QUARTZ	220.	MISC ROCK (RHO<3.0)	310.1
WET QUARTZ	220.2	MISC ROCK (RHO>3.0)	310.2
POROUS QUARTZ	220.3	MISC ROCK (RHO>4.0)	310.3
FUSED QUARTZ	220.4	ME GROUT	330.
SANDSTONE	223.	GROUT	330.1
SALT	270.	CONCRETE	330.3
SHALE	280.	RHYOLITE	330.2
PHYLLITE	280.1	GROUT	330.3
TONALITE	224.	PUMICE	331.
DRY TUFF	230.1	GNEISS	370.
WET TUFF	230.2	AL2O3/EPOXY(40%)	400.1

Table 5-3. Materials stored in the METHUG.dat file (Unit 11) 11-11-93.

in order on file		in numerical order	
ALUMINUM - AL	13.	LITHIUM FLORIDE	3.1
ANTIMONY - SB	51.	LITHIUM DEUTERIDE	3.2
BERYLLIUM - BE	4.	BERYLLIUM - BE	4.
BISMUTH - BI	83.	MAGNESIUM - MG	12.
CADMIUM - CD	48.	PMMA	12.5
CHROMIUM - CR	24.	TEFLON	12.6
COBALT - CO	27.	ALUMINUM - AL	13.
COPPER - CU	29.	TITANIUM - TI	22.
GOLD - AU	79.	VALLADIUM - V	23.
INDIUM - IN	49.	CHROMIUM - CR	24.
IRON - FE (LLL NO. 41)	26.	IRON - FE (LLL NO. 41)	26.
LEAD - PB	82.	COBALT - CO	27.
MAGNESIUM - MG	12.	NICKEL - NI	28.
MOLYBDENUM- MO	42.	COPPER - CU	29.
NICKEL - NI	28.	BRASS	29.5
NIObIUM - NB	41.	ZINC - ZN	30.
PALLADIUM PD	46.	ZIRCONIUM - ZR	40.
PLATINUM - PT	78.	NIObIUM - NB	41.
RHODIUM - RH	45.	MOLYBDENUM- MO	42.
SILVER - AU	47.	RHODIUM - RH	45.
TANTALUM - TA	73.	PALLADIUM PD	46.
THALLIUM - TL	81.	SILVER - AU	47.
THORIUM - TH	90.	CADMIUM - CD	48.
TIN - SN	50.	INDIUM - IN	49.
TITANIUM - TI	22.	TIN - SN	50.
TUNGSTEN - W	74.	ANTIMONY - SB	51.
WC - TUNGSTEN CARBIDE	74.1	TANTALUM - TA	73.
VALLADIUM - V	23.	TUNGSTEN - W	74.
ZINC - ZN	30.	WC - TUNGSTEN CARBIDE	74.1
ZIRCONIUM - ZR	40.	PLATINUM - PT	78.
BRASS	29.5	GOLD - AU	79.
LITHIUM DEUTERIDE	3.2	THALLIUM - TL	81.
LITHIUM FLORIDE	3.1	LEAD - PB	82.
PMMA	12.5	BISMUTH - BI	83.
TEFLON	12.6	THORIUM - TH	90.

Table 5-4. Example of experimental Hugoniot data stored on the ROCKHUG.dat and METHUG.dat files.

DRY CALCITES				240.
HE	16.	5.90		
ID 2.29				KTECH (92e) SALEM LIME 9-18
SP	3.02	5.50	3554	
SP	2.40	8.80	3556	
SP	2.35	20.6	3558	
SP	2.52	35.7	3561	
SP 2.26		2.00	10.3	3564
ID 2.7				COLEMAN(92) DM1
SU	5.15	.86	.5'	
SU	4.83	.805	1'	
SU	4.83	.74	1'	
SU	4.55	.6	2'	
SU	4.47	.595	2.5'	
ID 2.70				KTECH (92a) DM MARBLE GAFFNEY 4-21
SP	6.094	11.84	3467	
SP	4.797	14.3	3469	
PS	4.0	54.3	"	
UP	0.91	102.5	3527	
UP 2.69		1.12	156.4	3513
ID 2.70				KTECH (92a) DM MARBLE GAFFNEY 4-21
UP	.051	12.4	3470	
UP	.571	48.	3471	
UP	.569	50.	3473	
UP	.054	12.5	3474	
UP	.532	51.	3475	
UP	.555	50.	3476	
ID				KTECH (92f) LIME
UP 2.8	.118	20.1	3489	
UP 2.79		.119	18.3	3490
UP 2.71		.200	24.3	3499
UP 2.69		.223	26.1	3492
UP 2.68		.220	28.7	3491
UP 2.75		.372	54.2	3497
UP 2.74		.377	59.7	3498
UP 2.73		.293	34.4	3503
UP 2.73		.345	39.2	3505
UP 2.75		.415	54.7	3504
ID				FURNISH(92A) DANBY MARBLE (4-17)
UP 2.694	0.114	15.4	DM6	
RA			DM6	
UP 2.694	0.605	66.5	DM7	
RA			DM7	
UP 2.694	0.679	83.7	DM8	
ND				**** end of DRY CALCITES data

Table 5-5. Material Us-Up relations available on USUP.dat file.

ID Num	Density (g/cc)	Material	Authors
108.	1.0	Water	CRT (92)
108.31	1.003	Water	BAKANOVA(76)
108.1	0.91	Ice	CRT (92)
211.31	2.21	Clay	TRUNIN(88)
222.1	2.62	Granite	Aherns et al
222.31	2.60	Granite	TRUNIN(88)
223.31		Sandstone	TRUNIN(88)
224.31	2.76	Siltstone	TRUNIN(88)
231.31	2.74	Tuff	TRUNIN(88)
231.32	1.89	DZ Tuff	CRT (92)
240.31	2.71	Danby Marble	CRT (92)
240.31	2.72	Limestone	TRUNIN(88)
240.32	2.84	Dolomite	TRUNIN(88)
310.21	2.74	Syenites	TRUNIN(88)
310.32	2.89	Gabbro	TRUNIN(88)
310.33	2.62	Porphyrites	TRUNIN(88)
310.34		Igneous rock	TRUNIN(88)
310.35		"	
330.0	1.95	MISTY ECHO Grout	CRT (92)
330.10	1.99	MISTY ECHO Grout	GERMAIN(92)
330.11	1.937	HPNS12 Grout	GERMAIN(92)
333.31	2.77	Shales	TRUNIN(88)
1.	1.193	LEXAN	Aherns et al
1.	0.055	Polystyrene	Aherns et al
3.130	2.641	LiF	FURNISH Aug(90)
3.140	2.64	LiF	STEINBERG (91), AHERNS, LANL(80)
13.0	2.785	Aluminum 2024	AHERNS ET AL (OCT 91)
13.31		Aluminum	TRUNIN(88)
13.32	2.78	Aluminum 2024L	LANL(80)
13.33	2.70	Aluminum 6061L	LANL(80)
13.40	2.70	Aluminum 6061S	STEINBERG(91)
13.35	2.80	Aluminum 7075L	LANL(80)
13.30	2.689	Aluminum	FURNISH Aug(90)
29.31		Copper	TRUNIN(88)
26.0	7.86	Steel 4340	CRT(92)
74.1	14.9	WC	CRT fit for KTech Tests
74.11	14.9	WC	CRT(92)
74.1	14.9	WC	STEINBERG (91)
73.30	16.66	Tantalum	AHERNS ET AL

5.2 RELEASE ADIABATS (RELAD.dat, 1-1-94).

The data describing the release paths are not stored as conveniently as the Hugoniot input since unknown values cannot be calculated from the measured data. Rather the suite of four variables (σ , ρ , U_p , and E) at points along a release path must be derived from the measurements and stored in the data base. Both 1d code calculations and LASS analysis are used to obtain the release paths.

Recent experiments in which 1D codes are used to derive the complete set of material properties are currently being incorporated into EXP and will become available in a later release. The current [1/1/94] release adiabat database (*RELAD.dat* on Unit 12) contains the 105 paths listed in Table 5-7. All of these data were obtained in reverse ballistic tests conducted by SNL; the shot names correspond to the Hugoniot data stored in the ROCKHUG and METHUG data files.

An example of the data for a single release path is included in Table 5-6. The data are stored in ASCII format to allow them to be easily updated and ported to any PC or workstation.

Table 5-6. Example of data on *RELAD.dat* (1-1-94).

P(MB)	DEN(g/cc)	Up(cm/us)	E(Terg/g)
23 BUL6	22		
4.1033E-01	3.8290E+00	3.3610E-01	5.6485E-02
4.0463E-01	3.8159E+00	3.3837E-01	5.6124E-02
4.0319E-01	3.8142E+00	3.3877E-01	5.6078E-02
4.0221E-01	3.8135E+00	3.3898E-01	5.6060E-02
4.0196E-01	3.8133E+00	3.3905E-01	5.6052E-02
4.0029E-01	3.8109E+00	3.3957E-01	5.5986E-02
3.9900E-01	3.8087E+00	3.4001E-01	5.5926E-02
3.9803E-01	3.8077E+00	3.4027E-01	5.5899E-02
3.9755E-01	3.8069E+00	3.4044E-01	5.5876E-02
3.9100E-01	3.7983E+00	3.4241E-01	5.5648E-02
3.6757E-01	3.7631E+00	3.5000E-01	5.4770E-02
3.4611E-01	3.7269E+00	3.5745E-01	5.3905E-02
3.2386E-01	3.6847E+00	3.6571E-01	5.2944E-02
3.0734E-01	3.6497E+00	3.7227E-01	5.2166E-02
2.9151E-01	3.6128E+00	3.7893E-01	5.1372E-02
2.7687E-01	3.5753E+00	3.8545E-01	5.0589E-02
2.6395E-01	3.5391E+00	3.9153E-01	4.9852E-02
2.5293E-01	3.5055E+00	3.9699E-01	4.9183E-02
2.4484E-01	3.4791E+00	4.0117E-01	4.8662E-02
2.4181E-01	3.4688E+00	4.0278E-01	4.8457E-02
2.3527E-01	3.4458E+00	4.0633E-01	4.8009E-02
2.2830E-01	3.4199E+00	4.1025E-01	4.7515E-02

Table 5-7. List of 105 sets of release Adiabats on RELAD.dat (1-1-94).

	SHOT NAME	num	Phug (mB)		SHOT NAME	num	Phug (mB)
1	DNA1	50	0.0419	51	HT4	50	0.0419
2	DNA2	50	0.0617	52	HT5	50	0.0851
3	DNA3	50	0.0834	53	HT6	50	0.0161
4	DNA4	50	0.1024	54	HT7	50	0.1068
5	DNA5	50	0.1197	55	HT8	50	0.1397
6	DNA6	50	0.1187	56	HT9	32	0.3504
7	DNA7	50	0.1512	57	HT10	20	0.5343
8	DNA8	50	0.1854	58	HT11	25	0.5717
9	DNA9	19	0.0487	59	HT12	50	0.0357
10	DNA11	20	0.0211	60	HT13	50	0.0770
11	DNA12	12	0.1639	61	BEX1	35	0.0996
12	DNA13	22	0.2457	62	BEX2	50	0.0385
13	DNA14	20	0.2861	63	BEX3	31	0.0646
14	DNA15A	47	0.3519	64	BEX4	36	0.1449
15	DNA16	19	0.4356	65	BEX5	49	0.1160
16	DNA18	15	0.4554	66	BEX6	50	0.0502
17	DNA19	14	0.5542	67	BEX7	50	0.0923
18	DNA20	15	0.6592	68	BEX8	50	0.1568
19	BUL2	50	0.0225	69	BEX11	50	0.1222
20	BUL3	43	0.1122	70	BEX13	25	0.1717
21	BUL4	28	0.2751	71	DLS1	36	0.0109
22	BUL5	16	0.4689	72	DLS3	30	0.0320
23	BUL6	22	0.4103	73	DLS6	26	0.1218
24	BUL7	16	1.0117	74	DLS8	34	0.0576
25	BUL8	11	0.1750	75	ILS1	50	0.0570
26	BUL	16	0.0503	76	ILS2	41	0.0792
27	NT2	42	0.0188	77	ILS3	34	0.0954
28	NT3	50	0.0640	78	ILS9	50	0.0129
29	NT4	50	0.0973	79	ILS10	50	0.0252
30	NT5	50	0.1196	80	ILS12	50	0.0449
31	NT6	48	0.0428	81	ILS13	47	0.0060
32	PT3	50	0.0577	82	ILS14	48	0.0405
33	PT4	44	0.0873	83	ILS15	45	0.0943
34	PT5	50	0.1329	84	PF2	50	0.0421
35	PT6	46	0.0181	85	DM1	49	0.0325
36	RT1	50	0.0155	86	DM2	50	0.0367
37	RT3	27	0.0603	87	DM3	50	0.0561
38	RT4A	50	0.1196	88	DM4	50	0.0985
39	RT5	50	0.0867	89	DM5	40	0.1302
40	RT6	50	0.0220	90	DM6	50	0.0160
41	TAN2	50	0.0778	91	DM7	50	0.0664
42	TAN3	50	0.1364	92	DM8	50	0.0830
43	TAN4	50	0.2299	93	DM9	50	0.1303
44	TAN7	17	0.4485	94	DM14	50	0.0443
45	TAN9	50	0.0293	95	DM15	50	0.0463
46	DZ1	50	0.0476	96	DM16	50	0.0586
47	DZ2	25	0.1249	97	DM17	50	0.0847
48	DZ3	10	0.3148	98	HT16	31	0.25817
49	DZ4	13	0.3866	99	HT17	31	0.20502
50	DZ5	21	0.5494	100	SLP1	40	0.05232
				101	SLP2	40	0.08612
				102	SLP3	30	0.16274
				103	SLP4	27	0.26580
				104	SLP6	11	1.39710
				105	SLP7	26	0.65713

5.3 MATERIAL MODELS (EOSS.dat) 1-1-94.

In addition to the experimental data bases, TRT maintains a file containing the input decks for a large number of material models, for example there are 24 different HE materials available. While the emphasis of the table was to preserve the models of various geologic materials used in DNA calculational efforts, EOS models for metals, plastics and other materials that were developed under DNA and WES programs are included in the data file. The materials whose EOS models are store in the EOSS.dat data base are listed in Table 5-8 below.

Table 5-8. Listing of the EOS models in the EOSS.dat data file,
Tape 14 as of 10/27/93.

rocks -- water -- ice -- grouts									
ICE	H2ON	HTH3	DZ2	DZ5	TEN6	TUF58			
LMSO23	LMST01	DM2GR1	DMM001	LTRM20	SBAGS				
SHALE	BXR6	BXR8	BXR12	BXR13	MES2	MES195			
metals -- plastics -- etc									
STEEL	AL	WC	TA	TAHY	TAHMY	TEFLON	FOAM40	PMMA	LIF
High Explosives									
AIR	ANFO	ATX	COMPB	C4	DSHTA	DSHTC			
H6	MEN2	NM	NM78	PBX944					
PETN	PETNA	PETNB	PETNC	PETNS	PXN103	N103			
RX39A	RX39B	TNT85	TNT83	TNT72	9404				

5.4 HYDROPLUS ARCHIVAL DATABASES.

5.4.1 Introduction.

To assist in maintaining the documentation required by the HYDROPLUS yield verification program, a single collection point for data was established for DNA on the CFS (Common File Storage) system at LANL. A number of different organizations and agencies were involved in fielding gages, measuring equation of state properties, calculating probable ground response and making yield estimates. The nature of the HYDROPLUS yield estimation required close communication between these groups and the ability to store and share files. The Common File System (CFS) at LANL was chosen as a suitable location for such a database since all of the organizations have access to it. Titan Research and Technology, TRT (formerly CRT), created two directories to serve as the repositories on the CFS. The first is primarily for equation of state data and numerical calculations and is unclassified; the second, located in the classified partition of the CFS, contains summaries of the data from the five HYDROPLUS nuclear tests fired to date.

5.4.2 Equation of State/Numerical Results.

The EOS database contains Hugoniot points and release adiabat paths for specific materials of interest to the HYDROPLUS program. These have been culled from the open literature, i.e., the files described in Section 5.1, and augmented by specific HYDROPLUS-sponsored high-velocity impact tests on small samples. The materials included are tabulated below. Release adiabats for materials tested by Sandia are contained in a single file, *rel-sum.std*. These materials include tuff, rhyolite, and limestone. A complete list of the files in the unclassified database is included in Appendix A. Several text files [readme.--] are interspersed throughout the file to aid the user in finding any specific data set.

In addition to the experimental EOS data sets listed in Table 5-9, calculational models are also included in the database. Each of the three organizations that participated in HYDROPLUS ground shock calculations [CRT, SAIC, and SCUBED] has a subdirectory in which to collect their relevant files. All users have access rights which allow them to add files to the notredame directory, however, once the files have been created, only TRT can delete or modify them. This scheme is designed to centralize changes and maintain accountability.

Table 5-9. Materials in HYDROPLUS EOS database.

Material	file(s)	date of last entry
rhyolite	bexarhug.std, rhyolite.std	1-22-91, 3-8-93
wet tuff	bullionhug.std, tenabohug.std, wet_tuff.std	1-25-91, 1-25-91, 3-8-93
dry tuff	dry_tuff.std	3-8-93
ME grout	mistyechohug.std, megrout.std	1-25-91, 3-8-93
low-porosity limestone, marble, calcite, aragonite	sol-lime-plus.s	3-8-93
dry calcite	dry_calcite.std	3-8-93
wet calcite	wet_calcite.std	3-8-93
single crystal calcite	sngcryscalcite.s	3-8-93
shale	shale.std	3-8-93
water	water.std	3-8-93
ice	ice.std	3-8-93
Al ₂ O ₃ /epoxy(40%)	epoxy.std	3-8-93
misc. grout	grout.std	3-8-93
sandstone	sandstone.std	3-8-93

These files are all stored at Los Alamos (LANL) on the common file system (CFS) in the root directory */notredame*. Potential users may contact DNAFC, Eric Rinehart, for the password. The files are predominantly stored in standard format. Standard format is produced by running STTEXT on an ASCII file. The file may then be retrieved onto a variety of machines using a local NTEXT utility which converts the files back into native ASCII format on the users' machine. This makes it possible to retrieve the files on such diverse systems as a VAX or UNIX machine. Once there, any standard text editor or word processor may be used to view the file.

5.4.3 Nuclear Shot Data.

There have been five nuclear tests on which HYDROPLUS gages were fielded and a yield estimate made. BULLION and TENABO were 'standard' tests as regards the Threshold Test Ban Treaty (TTBT). Both events were shots fired in canisters emplaced in vertical drill holes in tuff at NTS. BEXAR was emplaced in a vertical drill hole in rhyolite. DISTANT ZENITH and HUNTERS TROPHY were horizontal tunnel shots in tuff.

The purpose of maintaining a HYDROPLUS database is to provide the HYDROPLUS community with a single, definitive set of results for each event in which it participates. The bibliography accompanying the data provides the necessary paper trail and a library of the referenced reports is maintained at TRT.

Each nuclear test has been summarized in an EXCEL spreadsheet. This allows the inclusion of graphics to illustrate the configuration of each test. While each summary has a slightly different format to accommodate the unique configuration of each test, in general there are sections describing:

- geometry
- media
- yield
- gage locations
- gage measurements, both the initial quick look and latest best value and the free-field equivalent, i.e., borehole corrected
- plots of peak pressure and velocity vs range
- references

These spreadsheets are stored on CFS in the directory */hat*. The formats are:

1. The encoded binary EXCEL file (.EXL). This file is encoded with UUENCODE; a copy of which is available to users in the unclassified */notredame* directory, Appendix A. These are shareware routines that preserve the PC file format.
2. An ASCII equivalent text file (.TXT) suitable for viewing/editing on the DNA CRAY/VAX system at LANL. The graphics cannot be included in this file.
3. A comma-delimited version (.CSV) for reading into spreadsheet programs that can not read EXCEL files. As might be expected, This format does not contain graphics.

An unclassified example of the HUNTERS TROPHY data is included as Appendix B.

APPENDIX A

LIST OF FILES IN UNCLASSIFIED DIRECTORY

DIRECTORY OF CFS /NOTREDAME	AS OF	8 March 1993	NAME	FORMAT	DATE	ORIGINATOR	DESCRIPTION
README.STD	STANDARD	93-03-08	CRT - AVC	This directory listing & general information about files			
EOS DATA							
README-HUG.STD	STANDARD	90/09/30	CRT - AVC	DESCRIPTION OF HUGONIOT FILES			
BEXARHUG.STD	STANDARD	91/01/22	CRT - ESS	RHYOLITE EXPERIMENTAL HUGONIOT DATA			
BULLIONHUG.STD	STANDARD	91/01/25	CRT - ESS	WET TUFF EXPERIMENTAL HUGONIOT DATA 1.75<RHO<1.90			
MISTYCHOHUG.STD	STANDARD	91/01/25	CRT - ESS	MISTY ECHO EXPERIMENTAL HUGONIOT DATA			
TENABOHUG.STD	STANDARD	91/01/25	CRT - ESS	WET TUFF EXPERIMENTAL HUGONIOT DATA 1.80<RHO<2.05			
DRY_TUFF.STD	STANDARD	93-03-08	CRT - AVC	DRY TUFF HUGONIOT DATA.			
WET_TUFF.STD	STANDARD	93-03-08	CRT - AVC	WET TUFF HUGONIOT DATA.			
SOL_LIME-PLUS.S	STANDARD	93-03-08	CRT - AVC	LOW-POROSITY LIMESTONE, MARBLE, CALCITE, ARAGONITE			
HUGONIOT DATA							
DRY_CALCITE.STD	STANDARD	93-03-08	CRT - AVC	DRY CALCITE HUGONIOT DATA			
WET_CALCITE.STD	STANDARD	93-03-08	CRT - AVC	WET CALCITE HUGONIOT DATA			
SNGCRYSALCALCITE.S	STANDARD	93-03-08	CRT - AVC	SINGLE CRYSTAL CALCITE HUGONIOT DATA			
SHALE.STD	STANDARD	93-03-08	CRT - AVC	SHALE HUGONIOT DATA			
WATER.STD	STANDARD	93-03-08	CRT - AVC	WATER HUGONIOT DATA			
ICE.STD	STANDARD	93-03-08	CRT - AVC	ICE HUGONIOT DATA			
EPOXY.STD	STANDARD	93-03-08	CRT - AVC	AL203/EPOXY(40%) HUGONIOT DATA			
MEGROUT.STD	STANDARD	93-03-08	CRT - AVC	ME GROUT HUGONIOT DATA			
GROUT.STD	STANDARD	93-03-08	CRT - AVC	OTHER GROUTS HUGONIOT DATA			
RHYOLITE.STD	STANDARD	93-03-08	CRT - AVC	SHALE HUGONIOT DATA			
SANDSTONE.STD	STANDARD	93-03-08	CRT - AVC	SANDSTONE HUGONIOT DATA			
REL-LIST.STD	STANDARD	93-03-08	CRT - AVC	LIST OF RELEASE ADIABAT DATA FROM SNL			
REL-SUM.STD	STANDARD	93-03-08	CRT - AVC	SANDIA LAB EXPERIMENTAL RELEASE DATA			
CRT subdirectory							
EOS MODELS							
SHEL.EOS.STD	STANDARD	90/11/28	CRT - ESS	SHEL EOS FORTRAN CODE			
TUF58EOS.INP	CRAY NAT	90/12/04	CRT - ESS	TUF58 EOS INPUT DATA			
TUF58HUG.STD	STANDARD	90/12/03	CRT - ESS	TUF58 EOS HUGONIOT (for BULLION)			
TEN6HUG.STD	STANDARD	90/12/03	CRT - ESS	TEN6 EOS HUGONIOT (for TENABO)			
BXR8HUG.STD	STANDARD	91/09/03	CRT - AVC	BXR8 EOS HUGONIOT (for BEXAR)			
DZZHUG.STD	STANDARD	91/09/03	CRT - AVC	DZZ EOS HUGONIOT (for DISTANT ZENITH)			

DZ5-HUG.STD	STANDARD	92/09/30	CRT - AVC	DZ5 EOS HUGONIOT
HTH3-HUG.STD	STANDARD	92/09/30	CRT - AVC	HTH3 EOS HUGONIOT
CALCULATION OUTPUT				
TUF58-PEAKS.STD	STANDARD	90/11/28	CRT - ESS	EOS TUF58 PEAK ATTENUATION COARSE ZONED CASE
TUF58-FINE.STD	STANDARD	90/12/04	CRT - ESS	EOS TUF58 PEAK ATTENUATION FINE ZONED CASE
TEN6-FINE.STD	STANDARD	90/12/03	CRT - ESS	EOS TEN6 PEAK ATTENUATION FINE ZONED CASE
S3DAT.STD	STANDARD	90/12/03	CRT - ESS	S3 EOS IN CRALE CODE PEAK ATTENUATION
BXR8-PEAKS.STD	STANDARD	91/03/15	CRT - ESS	EOS BXR8 PEAK ATTENUATION FINE ZONED
CRT-BEX-MIX.STD	STANDARD	91/04/01	CRT - ESS	EOS BEX-MIXTURE PEAK ATTENUATION FINE ZONED
CRT-DZ-2D.STD	STANDARD	91/09/18	CRT - AVC	DISTANT ZENITH PREDICTI.
HT-STAND.STD	STANDARD	93/01/12	CRT - AVC	HT calculational standards
CALCSTAN-FOR.STD	STANDARD	93/01/12	CRT - AVC	program to estimate yield from standards
HTEXP-SAMPLE.STD	STANDARD	93/01/12	CRT - AVC	sample input for above program
CRT-DZPARM subdirectory.....				
IDREADME	UNICOS-NAT	92/06/10	CRT - ESS	
CRT01.STD	STANDARD	92/06/10	CRT - ESS	DZ PARAMETER STUDY
CRT02A.STD	STANDARD	92/06/10	CRT - ESS	DZ PARAMETER STUDY
CRT02B.STD	STANDARD	92/06/10	CRT - ESS	DZ PARAMETER STUDY
CRT02C.STD	STANDARD	92/06/10	CRT - ESS	DZ PARAMETER STUDY
CRT04A.STD	STANDARD	92/06/10	CRT - ESS	DZ PARAMETER STUDY
CRT04B.STD	STANDARD	92/06/10	CRT - ESS	DZ PARAMETER STUDY
CRT04C.STD	STANDARD	92/06/10	CRT - ESS	DZ PARAMETER STUDY
CRT06A.STD	STANDARD	92/06/10	CRT - ESS	DZ PARAMETER STUDY
CRT06B.STD	STANDARD	92/06/10	CRT - ESS	DZ PARAMETER STUDY

SCUBED subdirectory -----				
readme.scubed	unicos	91/08/01	sss - jcb	info on contents of this directory
bexar.hugoniot	unicos	91/08/01	sss - jcb	scubed rhyolite hugoniot
rhyolt.f	unicos	91/08/01	sss - jcb	scubed rhyolite routine
rhyolite.adiabat	unicos	91/08/01	sss - jcb	scubed rhyolite data file
hydro885	unicos bin	91/08/01	sss - jcb	scubed rhyolite data file
SCUBEDS3.STD	STANDARD	91/01/25		S3 EOS IN SCUBED CODE PEAK ATTENUATION
SCUBED-BEX.STD	STANDARD	91/03/29	S3 - JCB	S3 NEW BEXAR EOS PEAK ATTENUATION
scubed.ltl.close	unicos	91/10/02	S3 - JW	S3 ID BEXAR calc lkt close-in attenuations
ascii.dump.z	unicos comp.			DZ 2D dump for overlay
ascii.dmp.1472.z	unicos comp.			DZ 2D dump for overlay
dz1s.ed01884.z	unicos comp.			DZ 2D dump edit
dz1s.ed01472.z	unicos comp.			DZ 2D dump edit
mfcad.f	unicos			reads dumps
pload.f	unicos	91/12/09	S3 - JW	pressure boundary FORTRAN
dzstuff subsubdirectory				

peak values at gage locations for DZ calcs

dz.peaks unicos 92/03/03 S3 - Wiehe
 dzuff.hugoniol unicos 92/03/03 S3 - Wiehe
 readme.dztuff unicos 92/03/03 S3 - Wiehe
 sio2.adiabat unicos 92/03/03 S3 - Wiehe
 sio2.f unicos 92/03/03 S3 - Wiehe
 hydro177 unicos 92/03/03 S3 - Wiehe

ht7tuff subsubdirectory unicos 92/10/05 S3 - Murphy
 htuff.hugoniol unicos 92/10/05 S3 - Murphy
 readme.htuff unicos 92/10/05 S3 - Murphy
 sio2.adiabat unicos 92/10/05 S3 - Murphy
 sio2.f unicos 92/10/05 S3 - Murphy
 hydro177 unicos 92/10/05 S3 - Murphy

dzparamstudy subsubdirectory unicos 92/05/27 S3 - MH
 putrfile_prob1 unicos 92/05/27 S3 - MH
 putrfile_prob2 unicos 92/05/27 S3 - MH
 putrfile_prob2b unicos 92/05/27 S3 - MH
 putrfile_prob3b unicos 92/05/27 S3 - MH
 putrfile_prob3c unicos 92/05/27 S3 - MH
 putrfile_prob4 unicos 92/05/27 S3 - MH
 putrfile_prob5a unicos 92/05/27 S3 - MH
 putrfile_prob5b unicos 92/05/27 S3 - MH
 DZ parameter study peak lists
 DZ parameter study peak lists
 DZ parameter study peak lists
 DZ parameter study peak lists
 DZ parameter study peak lists
 DZ parameter study peak lists
 DZ parameter study peak lists
 DZ parameter study peak lists

SAIC subdirectory -----
 PTBULLIONHUG.STD STANDARD 92/08/06 PT - MF PACTECH EOS FOR BULLION
 PTBULLION.STD STANDARD 92/08/06 PT - MF PACTECH ATTENUATIONS FOR BULLION
 PACTECS3.STD STANDARD 91/01/25 S3 EOS IN PACTEC CODE PEAK ATTENUATION

SAI-BEXAR.CRAY CTSS
 SAI-BEXAR.STD STANDARD
 HT-GAUGE-HOC.STD STANDARD 92/09/15 SAI - JK HUNTERS TROPHY GAUGE LOCATIONS
 putrfile-hb-01.01 STANDARD 93/03/15 SAI - JK outline of HP handbook

1dtamped.std standard 91/04/05 S3 - DOD HT calc - see readme file
 2dtamped.std standard 91/04/08 S3 - DOD HT calc - see readme file
 radial.std standard 91/04/05 S3 - DOD HT calc - see readme file
 upaxis.std standard 91/04/05 S3 - DOD HT calc - see readme file
 dnaxis.std standard 91/04/05 S3 - DOD HT calc - see readme file
 upgageln.std standard 91/04/05 S3 - DOD HT calc - see readme file
 dngageln.std standard 91/04/05 S3 - DOD HT calc - see readme file
 readme.std standard 91/04/05 S3 - DOD HT calc - see readme file

HUNTERS TROPHY

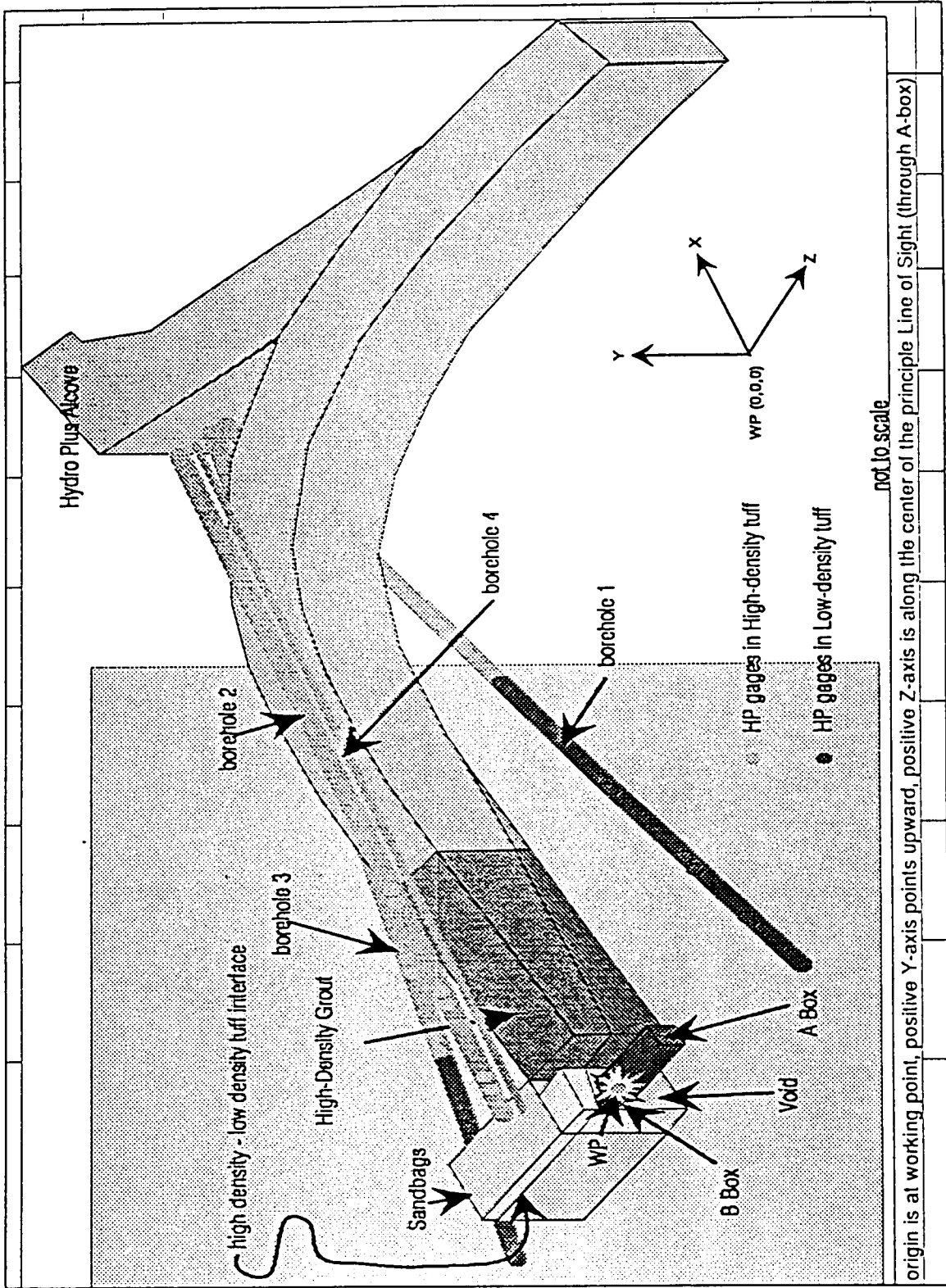

HUNTERS TROPHY

MEDIA	density (gm/cc)	porosity (%)	saturation (%)	solid grain density	water by weight (%)	air voids (%)
low-density tuff T14H [HT-1]	1.89	39.7	97	2.45		1.3
High-density tuff T14J [HT-1]	2.00	30.8	100	2.5		0.0
LTRM-20: high-density grout in bypass drift [HT-3]	2.16				23.3	4.0
grout in boreholes						
sandbags	1.55			2.65		
YIELD						
	nominal	HP D+6hr	HP D+30 [HT-9]	seismic	rad chem	CORRTEX FDR
yield (kt)	?		?	???	???	???
95% confidence interval			+/- 0.6			

HUNTERS TROPHY

GAGES	[HT-4]	see above sketch for coordinate system -- origin is at WP			r (m) -- radius from z-axis (LOS)	slant range (m)				
	x (m)	y(m)	z (m)							
borehole 1										
K11	4.611	-3.882	3.828	6.027	7.14					
K12	8.135	-3.126	3.224	8.715	9.292					
K13	11.671	-2.419	2.66	11.919	12.212					
FP11	5.636	-3.808	3.759	6.802	7.772					
FP12	9.188	-3.05	3.154	9.681	10.182					
FP13	12.711	-2.272	2.537	12.912	13.159					
borehole 2										
K21	4.735	4.363	-0.594	6.439	6.466					
K22	8.704	3.562	-0.638	9.405	9.427					
K23	12.426	2.787	-0.673	12.735	12.753					
FP21	5.978	4.193	-0.635	7.302	7.329					
FP22	9.894	3.424	-0.687	10.47	10.493					
FP23	13.467	2.656	-0.708	13.726	13.745					
borehole 3										
K31	6.17	0.568	-6.2	6.196	8.765					
K32	9.602	0.471	-4.908	9.614	10.794					
K33	13.024	0.373	-3.62	13.03	13.523					
FP31	7.187	0.544	-5.907	7.207	9.318					
FP32	10.617	0.45	-4.617	10.627	11.586					
FP33	14.055	0.352	-3.328	14.059	14.448					

HUNTERS TROPHY

GAGE MEASUREMENTS [HT-7]		D+6hr Pressure (kbar)	D+6hr Velocity (m/s)	D+6hr TOA (ms)	[HT-10] latest pressure (kbar) po S U	latest velocity (m/s)	latest TOA (ms)	Shock Speed (m/s)	[HT-11] borehole-corrected pressure (kbar)	borehole-corrected velocity (m/s)
borehole 1										
K11		?	?	?	?	?	?	?		
K12		?	?	?	?	?	?	?		
K13		?	?	?	?	?	?	?		
FP11		?		?	?	?	?			
FP12		?		?	?					
FP13		?		?	?					
borehole 2										
		D+6hr Pressure (kbar)	D+6hr Velocity (m/s)	D+6hr TOA (ms)	latest pressure (kbar) po S U	latest velocity (m/s)	latest TOA (ms)	Shock Speed (m/s)	borehole-corrected pressure (kbar)	borehole-corrected velocity (m/s)
K21		?	?	?	?	?	?	?		
K22		?	?	?	?	?	?	?		
K23		?	?	?	?	?	?	?		
FP21		earthquake damage		?	no data					
FP22		?		?						
FP23		?		?						
borehole 3										
		D+6hr Pressure (kbar)	D+6hr Velocity (m/s)	D+6hr TOA (ms)	latest pressure (kbar) po S U	latest velocity (m/s)	latest TOA (ms)	Shock Speed (m/s)	borehole-corrected pressure (kbar)	borehole-corrected velocity (m/s)
K31		?	?	?	?	?	?	?		
K32		?	?	?	?	?	?	?		
K33		?	?	?	?	?	?	?		
FP31		?		?	?	?	?			
FP32		?		?	?					
FP33		?		?	?					

HUNTERS TROPHY

MEASUREMENT UNCERTAINTIES	[HT-]		[HT-10]			
	D+6hr Pressure +/- 2σ (kb)	D+6hr Velocity +/- 2σ (m/s)	D+6hr TOA +/- 2σ (ms)	latest pressure +/- 2σ (kb)	latest velocity +/- 2σ (m/s)	latest TOA shock speed +/- 2σ (m/s)
borehole 1						
K11				?	?	?
K12				?	?	?
K13				?	?	?
FP11				?		
FP12				?		
FP13				?		
borehole 2						
	D+6hr Pressure +/- 2σ (kb)	D+6hr Velocity +/- 2σ (m/s)	D+6hr TOA +/- 2σ (ms)	latest pressure +/- 2σ (kb)	latest velocity +/- 2σ (m/s)	latest TOA shock speed +/- 2σ (m/s)
K21				?	?	?
K22				?	?	?
K23				?	?	?
FP21				?		
FP22				?		
FP23				?		
borehole 3						
	D+6hr Pressure +/- 2σ (kb)	D+6hr Velocity +/- 2σ (m/s)	D+6hr TOA +/- 2σ (ms)	latest pressure +/- 2σ (kb)	latest velocity +/- 2σ (m/s)	latest TOA shock speed +/- 2σ (m/s)
K31				?	?	?
K32				?	?	?
K33				?	?	?
FP31				?		
FP32				?		
FP33				?		

HUNTERS TROPHY

ASM gages [HT-5]	depth (m)	x (m)	y (m)	z (m)	r (m) -- radius from Z-axis	slant range (m)	TOA (ms)	TOA (ms) D gages
ASM-1	16.7	6.819	3.998	-0.596	7.905	7.927		
ASM-2	12.84	10.592	3.184	-0.623	11.06	11.078		
ASM-3	8.99	14.359	2.391	-0.664	14.557	14.572		
FDR [HT-5 & HT-6]	depth (m)	x (m)	y (m)	z (m)	r (m) -- radius from Z-axis	slant range (m)	TOA (ms)	TOA (ms) D gages
FR11 - COE								
FR11(front)	20.01	3.616	-4.138	3.928	5.495	6.755	?	?
FR11(back)	16.5	6.995	-3.393	3.34	7.775	8.462	?	?
FR11(front)	12.8	10.568	-2.649	2.727	10.895	11.231	?	?
FR11(front)	8.92	14.323	-1.907	2.088	14.449	14.599	?	?
FR12-F - COE								
FR12-B - COE								
FR12(back)	20.01	3.659	-4.261	4.021	5.616	6.907	?	?
FR12(back)	16.52	7.010	-3.52	3.437	7.852	8.571	?	?
FR12(back)	12.83	10.58	-2.778	2.825	10.938	11.297	?	?
FR12(back)	8.94	14.343	-2.035	2.185	14.487	14.65	?	?
FR13(front)	19.99	3.635	-4.138	3.919	5.508	6.759		
FR13(front)	16.49	7.005	-3.395	3.333	7.784	8.468		
FR13(front)	12.79	10.577	-2.651	2.719	10.904	11.238		
FR13(front)	8.9	14.342	-1.907	2.079	14.468	14.617	?	?
FR21 - COE								
FR21(front)	19.65	3.926	4.574	-0.498	6.027	6.048	?	?
FR21(front)	16.14	7.355	3.828	-0.515	8.292	8.308	?	?
FR21(front)	12.04	11.365	2.968	-0.545	11.746	11.759	?	?
FR21(front)	8.36	14.965	2.208	-0.59	15.127	15.139	?	?
FR22-F - COE								
FR22-B - COE								
FR22(back)	19.63	3.976	4.716	-0.557	6.168	6.193	?	?
FR22(back)	16.14	7.387	3.974	-0.574	8.388	8.407	?	?
FR22(back)	12.04	11.395	3.114	-0.604	11.813	11.828	?	?
FR22(back)	8.36	14.996	2.354	-0.649	15.179	15.193	?	?
FR23(front)	19.65	3.926	4.576	-0.492	6.029	6.049		

HUNTERS TROPHY

L11 front	r17	16.94	6.569	-3.459	3.436	7.425	8.181 ?
L11 front	r18	16.63	6.869	-3.395	3.384	7.662	8.376 ?
L11 front	r19	14.18	9.233	-2.897	2.978	9.676	10.124 ?
L11 front	r20	13.88	9.522	-2.836	2.928	9.936	10.358 ?
L11 front	r21	13.57	9.822	-2.775	2.876	10.207	10.604 ?
L11 front	r22	13.27	10.112	-2.716	2.827	10.471	10.846 ?
L11 front	r23	12.96	10.412	-2.656	2.775	10.745	11.098 ?
L11 front	r24	10.53	12.762	-2.181	2.372	12.947	13.162 ?
L11 front	r25	10.23	13.052	-2.126	2.323	13.224	13.427 ?
L11 front	r26	9.92	13.353	-2.068	2.273	13.512	13.702 ?
L11 front	r27	9.62	13.643	-2.013	2.224	13.791	13.969 ?
L11 front	r28	9.32	13.934	-1.957	2.175	14.071	14.238 ?
L12 back	r0	20.2	3.431	-4.154	3.981	5.388	6.699
L12 back	r1	20.5	3.142	-4.210	4.029	5.26	6.626
L12 back	r2	20.81	2.844	-4.285	4.08	5.142	6.564
L12 back	r3	21.11	2.555	-4.349	4.129	5.044	6.518
L12 back	r4	21.42	2.256	-4.414	4.179	4.958	6.484
L12 back	r5	21.72	1.967	-4.478	4.228	4.891	6.465
L12 back	r6	22.03	1.668	-4.544	4.278	4.841	6.46 ?
L12 back	r7	22.33	1.379	-4.608	4.326	4.81	6.469 ?
L12 back	r8	22.64	1.081	-4.673	4.376	4.797	6.493 ?
L12 back	r9	22.94	0.792	-4.737	4.424	4.803	6.53 ?
L12 back	r10	22.25	1.456	-4.591	4.313	4.816	6.465 ?
L12 back	r11	23.55	0.204	-4.87	4.523	4.874	6.65
L12 back	r12	23.86	-0.094	-4.939	4.573	4.94	6.731
L12 back	r13	24.17	-0.393	-5.007	4.623	5.023	6.826
L12 back	r14	21.31	2.403	-4.514	4.243	5.114	6.645 ?
L12 back	r15	21.01	2.692	-4.45	4.195	5.201	6.602 ?
L12 back	r16	20.7	2.991	-4.383	4.144	5.306	6.733 ?
L12 back	r17	20.39	3.289	-4.317	4.094	5.428	6.798 ?
L12 back	r18	17.85	5.735	-3.776	3.67	6.866	7.786 ?
L12 back	r19	17.55	6.023	-3.712	3.62	7.075	7.948 ?
L12 back	r20	17.24	6.322	-3.646	3.568	7.298	8.123 ?
L12 back	r21	16.94	6.611	-3.582	3.518	7.519	8.301 ?
L12 back	r22	14.18	9.273	-3.02	3.06	9.752	10.221 ?
L12 back	r23	13.88	9.562	-2.958	3.01	10.009	10.452 ?
L12 back	r24	13.57	9.861	-2.898	2.959	10.278	10.696 ?
L12 back	r25	13.27	10.151	-2.839	2.909	10.541	10.935 ?
L12 back	r26	10.54	12.789	-2.306	2.457	12.996	13.226 ?

HUNTERS TROPHY

L12 back	r27	10.24	13.08	-2.251	2.408	13.272	13.489 ?		
L12 back	r28	9.93	13.381	-2.193	2.357	13.559	13.763 ?		
L12 back	r29	9.62	13.681	-2.136	2.307	13.847	14.037		
L21 front	r0	24.85	-1.163	5.645	-0.502	5.764	5.786		
L21 front	r1	24.55	-0.869	5.584	-0.503	5.651	5.673		
L21 front	r2	24.24	-0.566	5.52	-0.504	5.549	5.572		
L21 front	r3	23.94	-0.272	5.459	-0.504	5.465	5.489		
L21 front	r4	23.63	0.031	5.395	-0.505	5.395	5.419		
L21 front	r5	23.33	0.325	5.332	-0.507	5.342	5.366		
L21 front	r6	23.02	0.628	5.267	-0.508	5.304	5.329		
L21 front	r7	22.72	0.921	5.204	-0.51	5.284	5.309		
L21 front	r8	22.41	1.224	5.138	-0.512	5.282	5.307 ?		
L21 front	r9	22.11	1.517	5.075	-0.514	5.297	5.322 ?		
L21 front	r10	21.8	1.82	5.009	-0.516	5.33	5.355 ?		
L21 front	r11	21.5	2.113	4.946	-0.517	5.379	5.403 ?		
L21 front	r12	21.19	2.416	4.881	-0.519	5.446	5.471 ?		
L21 front	r13	20.89	2.709	4.817	-0.521	5.527	5.551 ?		
L21 front	r14	17.54	5.984	4.112	-0.535	7.261	7.28 ?		
L21 front	r15	17.24	6.277	4.047	-0.537	7.469	7.488 ?		
L21 front	r16	16.93	6.58	3.981	-0.539	7.69	7.709 ?		
L21 front	r17	16.63	6.873	3.916	-0.54	7.91	7.928 ?		
L21 front	r18	16.32	7.176	3.85	-0.542	8.143	8.161 ?		
L21 front	r19	13.48	9.952	3.25	-0.561	10.469	10.484 ?		
L21 front	r20	13.18	10.246	3.188	-0.564	10.73	10.745 ?		
L21 front	r21	12.87	10.549	3.123	-0.566	11.001	11.016 ?		
L21 front	r22	12.57	10.842	3.061	-0.568	11.266	11.28 ?		
L21 front	r23	12.26	11.145	2.996	-0.571	11.541	11.555 ?		
L21 front	r24	9.81	13.543	2.493	-0.597	13.771	13.784 ?		
L21 front	r25	9.51	13.837	2.431	-0.601	14.049	14.062 ?		
L21 front	r26	9.2	14.14	2.368	-0.604	14.337	14.35 ?		
L21 front	r27	8.9	14.433	2.305	-0.609	14.616	14.629 ?		
L21 front	r28	8.6	14.727	2.241	-0.614	14.896	14.909 ?		
L22 front	r0	21.31	2.299	4.906	-0.518	5.418	5.443		
L22 front	r1	21.61	2.006	4.969	-0.517	5.359	5.384		
L22 front	r2	21.92	1.703	5.035	-0.515	5.315	5.34		
L22 front	r3	22.22	1.409	5.098	-0.513	5.289	5.314		
L22 front	r4	22.53	1.106	5.164	-0.511	5.281	5.306 ?		
L22 front	r5	22.83	0.813	5.227	-0.509	5.29	5.314 ?		
L22 front	r6	23.14	0.51	5.292	-0.507	5.317	5.341 ?		

HUNTERS TROPHY

L22 front	r7	23.44	0.217	5.356	-0.506	5.36	5.384	?
L22 front	r8	23.75	-0.086	5.42	-0.505	5.42	5.444	?
L22 front	r9	24.05	-0.38	5.481	-0.504	5.494	5.517	?
L22 front	r10	24.36	-0.683	5.545	-0.503	5.587	5.609	?
L22 front	r11	24.66	-0.977	5.606	-0.503	5.691	5.713	?
L22 front	r12	24.97	-1.28	5.67	-0.502	5.813	5.834	?
L22 front	r13	25.27	-1.574	5.731	-0.501	5.943	5.964	?
L22 front	r14	21.03	2.603	4.989	-0.568	5.627	5.656	?
L22 front	r15	20.71	2.916	4.921	-0.57	5.72	5.749	?
L22 front	r16	20.4	3.219	4.856	-0.572	5.826	5.854	?
L22 front	r17	20.1	3.512	4.793	-0.573	5.942	5.97	?
L22 front	r18	17.54	6.015	4.253	-0.583	7.367	7.39	?
L22 front	r19	17.24	6.308	4.189	-0.585	7.572	7.595	?
L22 front	r20	16.93	6.611	4.122	-0.587	7.791	7.813	?
L22 front	r21	16.62	6.913	4.056	-0.589	8.015	8.037	?
L22 front	r22	13.48	9.982	3.392	-0.61	10.543	10.56	?
L22 front	r23	13.18	10.275	3.33	-0.612	10.802	10.819	?
L22 front	r24	12.87	10.578	3.265	-0.614	11.071	11.088	?
L22 front	r25	12.57	10.872	3.203	-0.616	11.334	11.351	?
L22 front	r26	9.82	13.563	2.637	-0.646	13.817	13.832	?
L22 front	r27	9.52	13.856	2.576	-0.649	14.094	14.108	?
L22 front	r28	9.21	14.16	2.512	-0.653	14.381	14.396	?
L22 front	r29	8.9	14.463	2.447	-0.657	14.669	14.684	?
L31 front	r0	23.43	1.063	0.773	-8.134	1.314	8.239	?
L31 front	r1	23.13	1.343	0.768	-8.026	1.547	8.174	?
L31 front	r2	22.82	1.632	0.762	-7.915	1.801	8.117	?
L31 front	r3	22.52	1.913	0.757	-7.808	2.057	8.074	?
L31 front	r4	22.21	2.202	0.749	-7.698	2.326	8.042	?
L31 front	r5	21.91	2.483	0.742	-7.591	2.592	8.021	?
L31 front	r6	21.6	2.772	0.735	-7.481	2.868	8.012	?
L31 front	r7	21.3	3.053	0.728	-7.374	3.139	8.014	?
L31 front	r8	20.99	3.343	0.721	-7.265	3.42	8.029	?
L31 front	r9	20.69	3.624	0.712	-7.159	3.693	8.056	?
L31 front	r10	20.38	3.914	0.703	-7.051	3.977	8.095	?
L31 front	r11	20.08	4.195	0.694	-6.945	4.252	8.144	?
L31 front	r12	19.77	4.485	0.685	-6.837	4.537	8.206	?
L31 front	r13	19.47	4.765	0.677	-6.731	4.813	8.275	?
L31 front	r14	16.8	7.26	0.607	-5.781	7.285	9.3	?
L31 front	r15	16.5	7.54	0.6	-5.674	7.564	9.456	?

HUNTERS TROPHY

L31 front	r16	16.19	7.829	0.593	-5.564	7.852	9.623
L31 front	r17	15.89	8.11	0.587	-5.457	8.131	9.793
L31 front	r18	15.58	8.399	0.58	-5.347	8.419	9.974
L31 front	r19	13.16	10.661	0.521	-4.488	10.674	11.579
L31 front	r20	12.86	10.942	0.511	-4.382	10.954	11.798
L31 front	r21	12.55	11.232	0.5	-4.272	11.243	12.027
L31 front	r22	12.25	11.512	0.49	-4.166	11.523	12.253
L31 front	r23	11.94	11.802	0.479	-4.057	11.812	12.489
L31 front	r24	9.49	14.094	0.383	-3.195	14.099	14.457
L31 front	r25	9.49	14.094	0.383	-3.195	14.099	14.457
L31 front	r26	9.19	14.374	0.369	-3.089	14.379	14.707
L31 front	r27	8.88	14.665	0.356	-2.981	14.669	14.969
L31 front	r28	8.58	14.945	0.342	-2.875	14.949	15.223
L31 front	r29	8.27	15.235	0.328	-2.767	15.239	15.488
L32 back	r0	19.92	4.345	0.689	-6.889	4.399	8.174
L32 back	r1	20.22	4.064	0.698	-6.995	4.124	8.12
L32 back	r2	20.53	3.774	0.707	-7.103	3.84	8.075
L32 back	r3	20.83	3.493	0.716	-7.209	3.566	8.042
L32 back	r4	21.14	3.203	0.725	-7.318	3.284	8.021
L32 back	r5	21.44	2.922	0.732	-7.424	3.012	8.012
L32 back	r6	21.75	2.632	0.739	-7.534	2.734	8.015
L32 back	r7	22.05	2.352	0.746	-7.641	2.467	8.029
L32 back	r8	22.36	2.062	0.753	-7.751	2.195	8.056
L32 back	r9	22.66	1.782	0.76	-7.857	1.937	8.093
L32 back	r10	22.97	1.492	0.765	-7.969	1.677	8.143
L32 back	r11	23.27	1.212	0.77	-8.076	1.436	8.203
L32 back	r12	23.58	0.923	0.776	-8.187	1.206	8.276
L32 back	r13	23.88	0.643	0.781	-8.295	1.012	8.356
L32 back	r14	20.32	4.024	0.711	-7.173	4.087	8.255
L32 back	r15	20.02	4.305	0.703	-7.067	4.362	8.305
L32 back	r16	19.71	4.595	0.693	-6.959	4.647	8.368
L32 back	r17	19.41	4.876	0.685	-6.852	4.924	8.438
L32 back	r18	16.81	7.305	0.617	-5.927	7.331	9.427
L32 back	r19	16.51	7.585	0.61	-5.82	7.609	9.58
L32 back	r20	16.2	7.875	0.604	-5.71	7.898	9.746
L32 back	r21	15.89	8.164	0.597	-5.6	8.186	9.918
L32 back	r22	13.15	10.725	0.531	-4.627	10.738	11.692
L32 back	r23	12.85	11.005	0.52	-4.521	11.018	11.909
L32 back	r24	12.54	11.295	0.51	-4.411	11.307	12.137

HUNTERS TROPHY

L32 back	r25	12.23	11.585	0.499	-4.302	11.596	12.368		
L32 back	r26	9.49	14.148	0.393	-3.338	14.153	14.542		
L32 back	r27	9.19	14.428	0.379	-3.232	14.433	14.791		
L32 back	r28	8.88	14.718	0.366	-3.124	14.723	15.051		
L32 back	r29	8.58	14.999	0.352	-3.018	15.003	15.304		

HUNTERS TROPHY

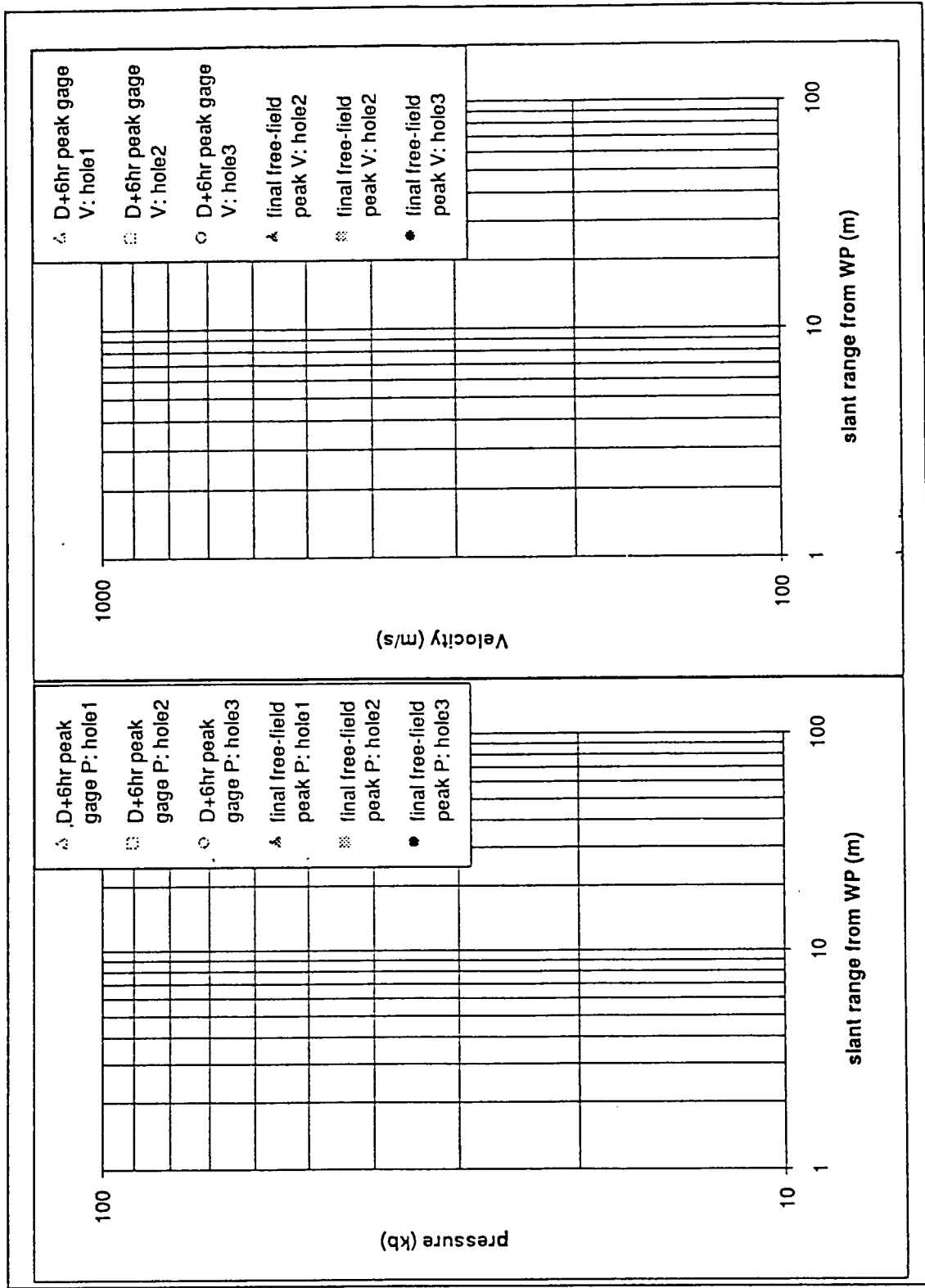

HUNTERS TROPHY

REFERENCES

- HT-1 (U) "Characterization of Material From Drill Hole U12n.24 GI#1"
TerraTek Inc., TR 91-127, July 1991
- HT-2 (U) "Nevada Test Site -- Area 12--D.O.D. HUNTERS TROPHY ----- U12n.24 Front End Stemming Plan"
Drawing # JS-012-U12n.24-C52, Raytheon Services Nevada, November 1991
- HT-3 (U) "Nevada Test Site -- Area 12--D.O.D. HUNTERS TROPHY ----- U12n.24 Stemming -- Mix Design"
Drawing # JS-012-U12n.24-C60.1, Raytheon Services Nevada, June 1991
- HT-4 (U) Klump, Jack, "Hunter's Trophy Hydro Plus gauge location coordinate transformation."
memorandum, SAIC, 8 September 1992
- HT-5 (U) Klump, Jack, "Gauge Location Coordinates", CFS file, SAIC,
9 September 1992.
- HT-6 (C-FRD) HUNTERS TROPHY FDR TOA DATA, 15 September 1992
- HT-7 (C-FRD) "Quick-look summary of Kratz Data" and "HUNTERS TROPHY flapack
TOA and peak stress", prepared on shot day for yield estimator's meeting, 18 September 1992
- HT-8 (C-FRD) Daniel, Russell, "HYDRO-PLUS/HUNTERS TROPHY TOA Preliminary Results",
memorandum, SAIC, 23 September 1992.
- HT-9 (C-FRD) Summa, William, "Summary of HYDRO-PLUS/HUNTERS TROPHY Yield Results",
memorandum, FCDNA, October 1992.
- HT-10 (C-FRD) Naegeli, Robert, "HYDRO-PLUS/HUNTERS TROPHY D+30 RESULTS MEETING --
Presentation Summary", held at FCDNA Office, South Tech Park, Las Vegas,
Nevada 19 October 1992, prepared by Tech. Reps., Inc., 23 October 1992
- HT-11 (U) Schuster, Shel, Estimate of impedance mismatch correction, CRT, November 1992.
- HT-12 (U) HUNTERS TROPHY Approximate Gauge-Line Layout, SAIC, September 1992.

HUNTERS TROPHY

CFS files in /notredame	
HT-stand.std	calculational standards
calcstan-for.std	program to estimate yield from calculational standards
HTexp-sample.std	sample input file for above program
/notredame/scubed/ht2tuff	directory contains files from Scubed calculation
/notredame/saic	directory contains files from SAIC calculation (see readme file)
sheleos.std	SHEL EOS FORTRAN code
DZ5-hug.std	CRT EOS model Hugoniot for low-density tuff
HTH3-hug.std	CRT EOS model Hugoniot for high-density tuff
wet_tuff.std	wet tuff Hugoniot data
HT-gauge-loc.std	gauge locations

DISTRIBUTION LIST

DNA-TR-93-187

DEPARTMENT OF DEFENSE

ASSISTANT TO THE SECRETARY OF DEFENSE
2 CY ATTN: EXECUTIVE ASSISTANT

DEFENSE INTELLIGENCE AGENCY
ATTN: DT-1

DEFENSE NUCLEAR AGENCY
ATTN: DFSP
ATTN: DFTD
ATTN: DFTD D LINGER
2 CY ATTN: IMTS
ATTN: SPWE
ATTN: TDTR F RENSVOID

DEFENSE TECHNICAL INFORMATION CENTER
2 CY ATTN: DTIC/OC

FIELD COMMAND DEFENSE NUCLEAR AGENCY
ATTN: FCTI G S LU
ATTN: FCTIP K SHAH
ATTN: FCTT-T E RINEHART
ATTN: FCTT DR BALADI
ATTN: FCTT J HUGHES

OASD (ISP)
ATTN: LT COL R BAKER

UNDER SECRETARY OF DEFENSE (ACQ)
ATTN: DENNIS J GRANATO

DEPARTMENT OF THE AIR FORCE

PHILLIPS LABORATORY
2 CY ATTN: PL/SUL

DEPARTMENT OF ENERGY

LAWRENCE LIVERMORE NATIONAL LAB
ATTN: L-13 B DUNLAP
ATTN: L-22 R WARD
2 CY ATTN: TECH LIBRARY

LOS ALAMOS NATIONAL LABORATORY
2 CY ATTN: REPORT LIBRARY

SANDIA NATIONAL LABORATORIES
ATTN: A CHABAI DEPT-9311
ATTN: DIV 9321 W BOYER
2 CY ATTN: TECH LIB 3141

DEPARTMENT OF DEFENSE CONTRACTORS

JAYCOR
ATTN: CYRUS P KNOWLES

JAYCOR
ATTN: R POLL

KAMAN SCIENCES CORP
ATTN: DASIAI

KAMAN SCIENCES CORPORATION
2 CY ATTN: DASIAI

LOGICON R & D ASSOCIATES
ATTN: B KILLIAN
ATTN: L GERMAIN

MAXWELL LABORATORIES INC
ATTN: DR E PETERSON
ATTN: J MORRIS
ATTN: MARK GROETHE
ATTN: P COLEMAN
ATTN: S PEYTON

SCIENCE APPLICATIONS INTL CORP
ATTN: DAN PATCH
ATTN: DR M MCKAY
ATTN: L SCOTT

SCIENCE APPLICATIONS INTL CORP
4 CY ATTN: K SITES

SRI INTERNATIONAL
ATTN: DR JIM GRAN
ATTN: P DE CARLI

TECH REPS, INC
ATTN: F MCMULLAN
ATTN: R NAEGELI

TITAN CORPORATION (THE)
2 CY ATTN: S SCHUSTER