



**US Army Corps  
of Engineers**

Construction Engineering  
Research Laboratories

**USACERL Technical Report FE-94/23  
September 1994**

# Testing of Uninterruptible Power Supplies With Nonlinear Loads

by  
Gerald Heydt, Steve Briggs, Franklin Holcomb, Daiva Edgar

Uninterruptible power supplies (UPSs) are used to provide power to sensitive and critical loads when the commercial supply has been interrupted. These loads may be nonlinear, which in the military often includes communications equipment, adjustable speed drives, fluorescent lighting, and mainframe and small computers.

Most electrical characteristics of UPSs are not currently subject to codes and standards, and there are no military specifications for UPSs. Existing standards assume that UPSs will be operated with linear loads. Since most UPS systems are operated with nonlinear loads, there is concern that UPSs will suffer degraded performance or failure when operated with these loads. This work developed a test methodology by which UPS systems can be tested and their susceptibility to nonlinear loads be quantified. The tests measure load transfer, efficiency, heating, load support, voltage regulation, and isolation. Several commercially available UPS systems are recommended for testing.

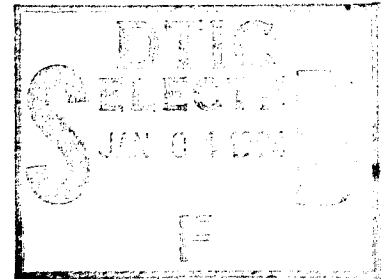

DTIC QUALITY INSPECTED &

19941229 059

The contents of this report are not to be used for advertising, publication, or promotional purposes. Citation of trade names does not constitute an official endorsement or approval of the use of such commercial products. The findings of this report are not to be construed as an official Department of the Army position, unless so designated by other authorized documents.

***DESTROY THIS REPORT WHEN IT IS NO LONGER NEEDED***

***DO NOT RETURN IT TO THE ORIGINATOR***

**USER EVALUATION OF REPORT**

REFERENCE: USACERL Technical Report FE-94/23, *Testing of Uninterruptible Power Supplies With Nonlinear Loads*

Please take a few minutes to answer the questions below, tear out this sheet, and return it to USACERL. As user of this report, your customer comments will provide USACERL with information essential for improving future reports.

1. Does this report satisfy a need? (Comment on purpose, related project, or other area of interest for which report will be used.)

---

---

---

2. How, specifically, is the report being used? (Information source, design data or procedure, management procedure, source of ideas, etc.)

---

---

3. Has the information in this report led to any quantitative savings as far as manhours/contract dollars saved, operating costs avoided, efficiencies achieved, etc.? If so, please elaborate.

---

---

4. What is your evaluation of this report in the following areas?

a. Presentation: \_\_\_\_\_

b. Completeness: \_\_\_\_\_

c. Easy to Understand: \_\_\_\_\_

d. Easy to Implement: \_\_\_\_\_

e. Adequate Reference Material: \_\_\_\_\_

f. Relates to Area of Interest: \_\_\_\_\_

g. Did the report meet your expectations? \_\_\_\_\_

h. Does the report raise unanswered questions? \_\_\_\_\_

i. General Comments. (Indicate what you think should be changed to make this report and future reports of this type more responsive to your needs, more usable, improve readability, etc.)

---

---

---

---

---

---

---

---

5. If you would like to be contacted by the personnel who prepared this report to raise specific questions or discuss the topic, please fill in the following information.

Name: \_\_\_\_\_

Telephone Number: \_\_\_\_\_

Organization Address: \_\_\_\_\_

6. Please mail the completed form to:

Department of the Army  
CONSTRUCTION ENGINEERING RESEARCH LABORATORIES  
ATTN: CECER-IMT  
P.O. Box 9005  
Champaign, IL 61826-9005

# REPORT DOCUMENTATION PAGE

Form Approved  
OMB No. 0704-0188

Public reporting burden for this collection of information is estimated to average 1 hour per response, including the time for reviewing instructions, searching existing data sources, gathering and maintaining the data needed, and completing and reviewing the collection of information. Send comments regarding this burden estimate or any other aspect of this collection of information, including suggestions for reducing this burden, to Washington Headquarters Services, Directorate for Information Operations and Reports, 1215 Jefferson Davis Highway, Suite 1204, Arlington, VA 22202-4302, and to the Office of Management and Budget, Paperwork Reduction Project (0704-0188), Washington, DC 20503.

1. AGENCY USE ONLY (Leave Blank)		2. REPORT DATE September 1994	3. REPORT TYPE AND DATES COVERED Final	
4. TITLE AND SUBTITLE Testing of Uninterruptible Power Supplies With Nonlinear Loads			5. FUNDING NUMBERS 4A162784 AT45 EX-XF3	
6. AUTHOR(S) Gerald Heydt, Steve Briggs, Franklin Holcomb, and Daiva Edgar				
7. PERFORMING ORGANIZATION NAME(S) AND ADDRESS(ES) U.S. Army Construction Engineering Research Laboratories (USACERL) P.O. Box 9005 Champaign, IL 61826-9005			8. PERFORMING ORGANIZATION REPORT NUMBER  FE-94/23	
9. SPONSORING / MONITORING AGENCY NAME(S) AND ADDRESS(ES) U.S. Army Center for Public Works (USACPW) ATTN: CECPW-EE 7701 Telegraph Road Alexandria, VA 22310-3862			10. SPONSORING / MONITORING AGENCY REPORT NUMBER	
11. SUPPLEMENTARY NOTES Copies are available from the National Technical Information Service, 5285 Port Royal Road, Springfield, VA 22161.				
12a. DISTRIBUTION / AVAILABILITY STATEMENT  Approved for public release; distribution is unlimited.			12b. DISTRIBUTION CODE	
13. ABSTRACT (Maximum 200 words)  Uninterruptible power supplies (UPSs) are used to provide power to sensitive and critical loads when the commercial supply has been interrupted. These loads may be nonlinear, which in the military often includes communications equipment, adjustable speed drives, fluorescent lighting, and mainframe and small computers.  Most electrical characteristics of UPSs are not currently subject to codes and standards, and there are no military specifications for UPSs. Existing standards assume that UPSs will be operated with linear loads. Since most UPS systems are operated with nonlinear loads, there is concern that UPSs will suffer degraded performance or failure when operated with these loads. This work developed a test methodology by which UPS systems can be tested and their susceptibility to nonlinear loads be quantified. The tests measure load transfer, efficiency, heating, load support, voltage regulation, and isolation. Several commercially available UPS systems are recommended for testing.				
14. SUBJECT TERMS nonlinear loads uninterruptible power supplies (UPSs) electrical distribution systems			15. NUMBER OF PAGES 88	
			16. PRICE CODE	
17. SECURITY CLASSIFICATION OF REPORT Unclassified	18. SECURITY CLASSIFICATION OF THIS PAGE Unclassified	19. SECURITY CLASSIFICATION OF ABSTRACT Unclassified	20. LIMITATION OF ABSTRACT  SAR	

# Foreword

This study was conducted for the U.S. Army Center for Public Works (USACPW) under Project 4A162784AT45, "Energy and Energy Conservation"; Work Unit EX-XF3, "Clean Electrical Power Technology." The technical monitor was Ronald Mundt, CECPW-EE.

The work was performed by the Energy and Utility Systems Division (FE) of the Infrastructure Laboratory (FL), U.S. Army Construction Engineering Research Laboratories (USACERL). Part of the work was performed under contract by Dr. Gerald Heydt of the Electrical Engineering Department, Purdue University. The USACERL principal investigator was Dr. Steve Briggs. Donald F. Fournier is Acting Chief, CECER-FE, and Dr. David Joncich is Acting Chief, CECER-FL. The USACERL technical editor was Thomas E. Rice, Information Management Office.

LTC David J. Rehbein is Commander and Acting Director of USACERL, and Dr. Michael J. O'Connor is Technical Director.

Approved	
Checked	<input checked="" type="checkbox"/>
DIC	<input type="checkbox"/>
Unannounced	<input type="checkbox"/>
Justification	
By	
Distribution	
Availability	
13.	
A-1	

# Contents

SF 298 .....	1
Foreword .....	2
List of Figures and Tables .....	5
<b>1 Introduction .....</b>	<b>11</b>
Background .....	11
Objective .....	11
Approach .....	12
Mode of Technology Transfer .....	12
<b>2 The Theory and Operation of Uninterruptible Power Supplies and Their     Susceptibility to Harmonic Load Currents .....</b>	<b>13</b>
Rotating UPS .....	13
Static UPS .....	15
Emergency Power Supplies .....	15
Susceptibility to Load Current Harmonics .....	16
Susceptibility to Other Power Quality Problems .....	17
Power Conditioners .....	17
<b>3 Impact of UPSs on AC Mains .....</b>	<b>24</b>
UPS as Seen From the AC Supply .....	24
Isolation of the Supply and Load Circuits .....	25
<b>4 Underwriters' Laboratories, Military, and Other Specifications for UPSs .....</b>	<b>28</b>
General .....	28
Underwriters' Laboratories Specification UL 1778 .....	29
Other Specifications .....	30
<b>5 Electrical Tests for the Susceptibility of UPSs to Harmonics and Other     Power Quality Problems .....</b>	<b>31</b>
Electrical Characteristics To Be Tested .....	31
A Test Set To Produce Harmonics in the Load Current .....	32
Test for Susceptibility of Load Transfer Time to Harmonic Load Currents .....	33
Test of UPS Efficiency Under Harmonic Load Current .....	35
Test for Susceptibility of UPS Heating Due to Harmonic Load Currents .....	37
Test for Degradation of Load Support Longevity to Harmonic Load Currents .....	38
Test for Susceptibility of Output Bus Voltage Regulation and Harmonic Content Due to Harmonic Load Currents .....	40
Test for Sensitivity of UPS Load Transfer Voltage Due to Harmonics in the Supply Voltage .....	42

Test of the UPS as a Power Conditioner and Isolation of the Load and Supply Busses (Test of Impulses Inserted in Load Circuit) .....	44
Test of the UPS as a Power Conditioner and Isolation of the Load and Supply Busses (Test of Impulses Inserted in Supply Circuit) .....	45
<b>6 Main UPS Manufacturers .....</b>	<b>68</b>
American Manufacturers .....	68
Foreign Manufacturers .....	68
UPSs Recommended for Testing .....	68
<b>7 Summary and Recommendations .....</b>	<b>76</b>
Summary of Tests .....	76
Recommendations .....	77
<b>References .....</b>	<b>78</b>
Cited References .....	78
Uncited References .....	78
<b>Glossary .....</b>	<b>80</b>
<b>Abbreviations and Acronyms .....</b>	<b>83</b>
<b>Distribution</b>	

## List of Figures and Tables

### Figures

1	Rotating uninterruptible power supply using diesel- or gasoline-powered generator. ....	18
2	Rotating uninterruptible power supply using batteries as the energy storage medium .....	18
3	Rotating uninterruptible power supply using a flywheel .....	19
4	Static uninterruptible power supply .....	20
5	Power conditioners used with a static UPS .....	21
6	Distortion in supply bus voltage of a UPS due to non-sinusoidal load current .....	21
7	Development of the transfer trip signal in a UPS .....	22
8	Propagation of load current impulse to the AC supply of a UPS .....	22
9	Line-side power conditioners .....	23
10	Load-side power conditioners .....	23
11	Typical isolation characteristics of static and rotary UPSs .....	27
12	Triac-switched resistive load for testing a UPS .....	47
13	Test set for producing a low-voltage condition at the supply side of the UPS .....	48
14	Recognizing the transfer time of a UPS upon application of a low-voltage condition .....	49
15	Typical times of transfer characteristic of a UPS .....	50

16	Basic test configuration for measuring the efficiency of a UPS .....	51
17	Expected efficiency characteristics of a UPS with nonlinear load .....	52
18	Measurement of the longevity of supporting a full load of a UPS for different harmonic load currents .....	53
19	Expected trend of longevity of load support versus load current THD .....	54
20	Expected trend of longevity of load support versus load current power factor .....	55
21	Load support time sensitivity to load current THD .....	55
22	Depiction of an ideal voltage source .....	56
23	Depiction of a nonideal voltage source and bus voltage distortion .....	56
24	Basic configuration of a test of UPS voltage regulation and voltage distortion due to a nonlinear load .....	57
25	Typical bus voltage regulation characteristics at the AC mains and at the load side of an unregulated UPS .....	58
26	Illustration of a test set to measure the susceptibility of a UPS to transfer load when the supply voltage is contaminated by harmonic components .....	59
27	Test set for the measurement of the susceptibility of a UPS to transfer load when the supply voltage is contaminated by harmonics .....	59
28	Illustration of the degradation of UPS load transfer trip point with increasing THD of the AC line voltage .....	61
29	Representation of the test of electrical isolation of a UPS by inserting impulses into the load circuit .....	62
30	Representation of the test of electrical isolation of a UPS by inserting impulses into the load circuit .....	62

31	Correct measurement of impulse amplitude for the impulse isolation test .....	64
32	Illustration of ringing in the load bus voltage (or the supply bus voltage) .....	64
33	Representation of the test of electrical isolation of a UPS by inserting impulses into the supply circuit .....	65
34	Test of electrical isolation of a UPS by inserting impulses into the supply circuit .....	66

### Tables

1	Typical power ratings and applications of UPSs .....	19
2	Main advantages and disadvantages of a rotating uninterruptible power supply .....	20
3	Isolation of load and AC supply circuits .....	27
4	Maximum surface temperatures of UPS cabinets and equipment according to UL 1778 .....	30
5	Power quality problems for which UPS operation may be susceptible to degraded performance .....	46
6	Circuit component values for a triac load test set .....	47
7	Load transfer time for different load current THDs .....	48
8	Component ratings and values for the low voltage test set depicted in 13 .....	49
9	A qualitative evaluation of UPS load transfer time versus load current THD .....	50
10	Capacitor ratings and values for the efficiency test set depicted in 16 .....	51
11	UPS efficiency test data .....	52

12	Qualitative assessment of the efficiency of a static UPS operating under distorted or undistorted load current . . . . .	53
13	Assessment of the temperature rise of UPSs under nonlinear load . . . . .	53
14	Longevity test data sheet . . . . .	54
15	Data taken in a test of UPS for output bus voltage regulation and harmonic content when the UPS is under nonlinear load . . . . .	57
16	Load bus voltage regulation when UPSs are used for nonlinear loads . . . . .	58
17	Ratings and component values for the test set shown in Figure 27 . . . . .	60
18	Ratings for the variac used for the test set shown in Figure 27 . . . . .	60
19	Voltage ratings for resistors used in the test set of Figure 27—for shock hazard prevention . . . . .	60
20	Data sheet for the test of the UPS load transfer points with distorted line voltage . . . . .	61
21	Component ratings and values for load- and line-side impulse test . . . . .	63
22	Switch settings in load- and line-side impulse test . . . . .	63
23	Data sheet for load-side impulse test . . . . .	65
24	Isolation of load and AC supply circuits . . . . .	65
25	Data sheet for line-side impulse test . . . . .	66
26	Ratings and values of L1 and C3 for the input impulse test . . . . .	67
27	UPSs of U.S. manufacture . . . . .	69
28	UPSs of foreign manufacture . . . . .	73

---

29	UPSs recommended for testing .....	73
30	Main electrical specifications for UPSs recommended for testing .....	74
31	Main mechanical specifications for UPSs recommended for testing .....	74
32	List prices for UPSs recommended for testing .....	75

# 1 Introduction

## Background

New types of electrical loads on power distribution systems, namely power electronic loads and computer loads, have accelerated in recent years. In the military, these nonlinear loads often include communications equipment, fluorescent lighting, and adjustable speed drive loads, with the largest nonlinear load often being mainframe and small computers. At some U.S. Army facilities the mainframe computer load predominates the entire building electrical demand. Many of these nonlinear loads are deemed critical enough to be supplied by power from uninterruptible power supplies (UPSs).

The main function of uninterruptible power supplies is to provide power to a load when the commercial mains supply has been interrupted. This power supply does not include long-term, temporary power, which is the function of an emergency or temporary power supply. A secondary function of a UPS is to condition the power supply (provide isolation between the load and supply busses) by blocking high voltages, spikes, ringing, and other high frequency phenomena so that these undesirable signals cannot pass between circuits.

Current specifications for UPS systems assume that UPSs will be operated with linear loads. Since most UPS systems are operated with nonlinear loads, there is concern that the UPSs will suffer degraded performances or failure when operated with these loads. Sound theoretical reasons exist for supposing that UPSs might be susceptible to nonlinear loads, but there are currently no hard data from testing of actual UPSs with nonlinear loads.

## Objective

The objective of this research is to develop a test methodology for evaluating the susceptibility of UPS systems to nonlinear loads.

## **Approach**

1. Information was gathered about the various types of UPSs currently available on the market to determine which varieties should be tested to provide meaningful guidance on their application with nonlinear loads.
2. The theory and operation of UPS systems was investigated to determine potential problems that UPS systems might experience under nonlinear loads.
3. A literature review was conducted to determine the applicability of other standards to the testing of UPS systems under nonlinear loads.
4. Based on the standards in step 3, a set of experiments was designed to test UPS systems in a range of designs for potential problems uncovered in step 2.

## **Mode of Technology Transfer**

The results of this research will be used as a basis for testing UPS systems. It is anticipated that recommendations for the manufacture and purchase of UPS systems will be incorporated into an Engineer Technical Letter or a Public Works Bulletin to be distributed by the U.S. Army Center for Public Works (USACPW), Fort Belvoir, VA.

## 2 The Theory and Operation of Uninterruptible Power Supplies and Their Susceptibility to Harmonic Load Currents

### Rotating UPS

The rotating UPS is an auxiliary generator with the capability of automatic rapid transfer of the load from the commercial power supply to an auxiliary generator when commercial power fails. There are three main types of rotating UPSs:

- Diesel- and gasoline-powered generator sets are used when anticipated line outages are lengthy (e.g., more than an hour). Figure 1\* shows a typical configuration of a diesel- or gasoline-powered generator set.
- Battery-powered motor/generator sets are used when the duration of anticipated outages is sufficiently short to be covered by battery energy storage (e.g., less than 1 hour). Figure 2 shows a typical configuration.
- Flywheel motor/generator sets are used when the anticipated duration of an outage is very short (e.g., less than 5 seconds). These sets give the advantage of 100 percent isolation from the supply line and a small measure of load support during an outage, yet the unit does not have the disadvantages associated with battery cost and maintenance and fuel storage. Figure 3 shows a typical configuration of a flywheel/motor generator set.

The main components found in most of the three main rotating UPSs are:

- A diesel or gasoline engine
- A fuel source for the operation of an engine
- A battery to operate the generator exciter, starter motor, and starter controls in the event of a power failure. The battery is trickle charged (i.e., low power, slow charge) from the commercial mains.
- A generator

---

\* Figures and tables are included at the end of their associated chapters.

- A transfer switch and associated sensory equipment for detection of loss of power from the commercial supply, and return to the commercial supply upon restoration of power.
- A flywheel to store rotating kinetic energy.

In addition to the elements depicted in Figures 1 through 3, there is often a voltage regulator that takes the load bus voltage as an input and the exciter operating level as an output. The function of the voltage regulator is to adjust the generator excitation to regulate the load bus voltage to within a prescribed percent of the rated voltage. Also, a surge suppressor may be used on the supply bus to limit the effect of high-voltage conditions in the alternating current (AC) supply (surges and spikes).

The main advantage of a rotating UPS is nearly total isolation from the AC supply. This occurs when the energy from the AC mains passes through a rotating shaft to the generator, which energizes the load; therefore, most spikes and other power quality problems are not passed through to the load. In this isolation, the frequency response of a rotating element is low at high frequency; therefore, the rotating shaft does not respond (i.e., change shaft speed) when short-duration spikes appear on the AC supply line. On the other hand, the frequency response of the rotating shaft is not so low at lower frequencies; AC mains voltage sags of a half-minute duration, for example, may pass on to the load as a voltage reduction. The greater the rotating shaft inertia, the greater the isolation of the load and supply.

A second advantage of some rotating UPSs (those that are diesel- and gasoline-powered, and certain battery-powered UPSs) is the length of time of support of the load. Gasoline, diesel, and large battery banks have the capability of high energy storage, and support of large loads for an hour or more is possible. These UPSs can have load support levels into the megawatt hour (MWh) range. Because of the nearly perfect isolation of the supply and load, and because of the long load support times, the rotating UPS has traditionally been the UPS of choice for mainframe computer installations and other large, critical loads. The computer power supply market, both mainframe and personal, dominates UPS sales. Table 1 shows typical power ratings and applications of UPSs.

The main disadvantages of rotating UPSs relate to the maintenance and losses associated with rotating elements. UPSs with large batteries have the added maintenance disadvantages of batteries (usually lead acid units). Size, weight, operating noise, environmental impact, and installation costs may be disadvantages for some applications of rotating UPSs.

The main advantages and disadvantages of rotating UPSs are listed in Table 2.

## Static UPS

The basic configuration of a static UPS is shown in Figure 4. The line supply (mains) is rectified to energize the internal direct current (DC) bus. The function of the DC bus filter is to limit the ripple voltage applied to the internal battery. This results in less power loss in the battery and lower operating temperature. Also, the filtering of the DC bus results in longer battery life. The inverter at the output side of the UPS converts the DC bus voltage to AC. Controls are needed to trickle charge the battery during normal operation. It is possible to enhance the operation of the UPS through the use of power conditioners at either the input or output side (see Figure 5). The function of the input-side power conditioner is to limit the supply bus voltage. The function of the output-side power conditioner is to ensure that the output AC bus is of sinusoidal waveshape and free of impulses and harmonics. The design of the input-side power conditioner varies considerably from the simple capacitor to a more expensive array of voltage-limiting filtering devices. In the latter category are rare-gas discharge tubes placed across the AC supply, filter capacitors, tuned filters, zinc oxide arresters, metal oxide varistors (MOVs), Zener diode protectors, spark gaps, and other devices. The design of the output-side power conditioner may include limited frequency response of the output inverter transformer, line filters, and filter capacitors. The power conditioners enhance the isolation of the input and output busses, and high quality UPSs will have elaborately designed electronic power conditioners.

## Emergency Power Supplies

The scope of this report does not include emergency or standby generators. These units are usually in the 10 kilovoltampere (kVA) class or larger, and they usually employ a diesel- or gasoline-engine-driven generator. The engine starts upon detection of loss of the AC mains. A load transfer switch is brought to the emergency position after the engine is started and the generator voltage stabilizes to a specified value. Most emergency power supplies of this design also use an electronic timing mechanism that does not allow repeated transfer of the load between the AC mains and the emergency generator; this type of chatter might occur if the AC supply was intermittent. The function of the timer logic is to start a countdown upon detection of loss of the AC mains and not allow retransfer from the emergency position to the normal position until the timer completes its cycle. Typical time settings for such a device are in the 60- to 200-second range.

## Susceptibility to Load Current Harmonics

A UPS senses line voltage to detect loss of commercial power. When AC supply main voltage drops below a preset level, a transfer of the load to the battery supply is initiated. If the AC supply bus voltage waveshape is distorted, the line voltage detection feature may malfunction. Most line voltage detectors are designed so that the supply bus voltage is rectified and the low frequency (e.g., 60 or 120 Hz) voltage in the resultant DC is filtered. The time constant of the filter is designed not to interfere with the speed of the transfer to the battery source. Some UPSs will also transfer to the battery source if a high voltage is detected. Spurious signals in the AC supply bus, such as harmonics, voltage spikes, ringing in the supply voltage, and other transient phenomena, may pass through the line voltage detection circuit. In this case, a false trip to the battery supply may occur.

The supply-side bus voltage distortion may be due to some external harmonic or other source remote to the UPS, or the AC mains voltage distortion may be caused by the load current of the UPS itself. This occurs for several reasons, but in all cases the supply bus voltage distortion is due to nonsinusoidal currents passing through distribution system impedance. This point is illustrated by Figure 6. Using the  $I_S$  and  $V_S$  notation in Figure 6, it is clear that if  $I_S$  is nonsinusoidal,  $V_S$  will also be nonsinusoidal; that is, the load current is passed onto the distribution system and is equal to the supply current.

The nonsinusoidal nature of  $I_S$  may be caused by nonsinusoidal load current that is of sufficient amplitude to allow the distortion to pass through the load-side converter and the supply-side rectifier. Also, the distortion of  $I_S$  will include the usual distortion associated with a rectifier supply current. In both cases, the effects are exaggerated (i.e., increased distortion of  $V_S$ ) if the AC supply bus is weak. The term weak refers to the case of high supply impedance (shown as  $Z_S$  in Figure 6). Note that for very high frequency phenomena in the load current,  $Z_S$  will increase since  $|Z_S|$  increases with frequency.

Usually the DC filter in the line voltage detector will sufficiently isolate the transfer circuit from the supply bus so that malfunction does not occur. However, as spurious voltages in the supply increase in amplitude, malfunction of the transfer may occur. This point raises the question whether transfer to the battery supply may be desirable when the AC supply bus is of poor power quality. No standard exists for this, but it is prudent to test candidate UPSs for susceptibility in load transfer to supply line power quality.

Figure 7 illustrates the problem just described. Note that the time constant in the DC bus filter, if chosen too long, could lengthen the load transfer time. However, if the DC

filter time constant were too short, high frequency signals in the supply might appear at the transfer trip signal. This condition is also illustrated in Figure 7.

## Susceptibility to Other Power Quality Problems

In this section, the foregoing material is extended to include other types of AC supply bus voltage distortion, which may be caused by pulses in the load current (see Figure 8) that can occur for electronically switched loads such as adjustable speed drive loads. The mechanism of propagation of the load current impulses to the supply current may be through the rectifier-inverter connection of the UPS itself or through capacitive coupling between the input and output circuits of the UPS.

Other power quality susceptibility problems relate to power quality in the supply bus voltage. In this case, distortion of the supply bus, probably due to an external source, results in malfunction of the transfer trip feature of the UPS. Problems fall into two categories: the poor power quality of the supply bus may disable or slow down the transfer trip feature of the UPS (i.e., the UPS falsely dismisses a low voltage or outage condition in the supply—termed a false dismissal), or the poor power quality in the supply bus may cause a false trip, known as a false alarm. Both the false alarm and false dismissal susceptibility of a UPS may be tested by evaluating the load transfer capability of the UPS under created conditions of poor supply voltage quality.

## Power Conditioners

The functions of line-side power conditioners are:

- To protect the UPS
- To provide additional isolation of the load bus from the supply bus
- To limit the UPS susceptibility to line-side power quality problems
- To limit the false alarm transfer trips of the UPS
- To limit the false dismissal or failure to trip
- In some cases, to filter the current presented to the distribution network by the UPS.

Typical designs of line-side power conditioners are depicted in Figure 9.

Common load-side power conditioners, which are usually tuned filters, are depicted in Figure 10. The common practice is to tune the filters at odd multiples of the power frequency (60 Hz). A detuning of about 0.5 Hz is used to limit current in the tuned filter.

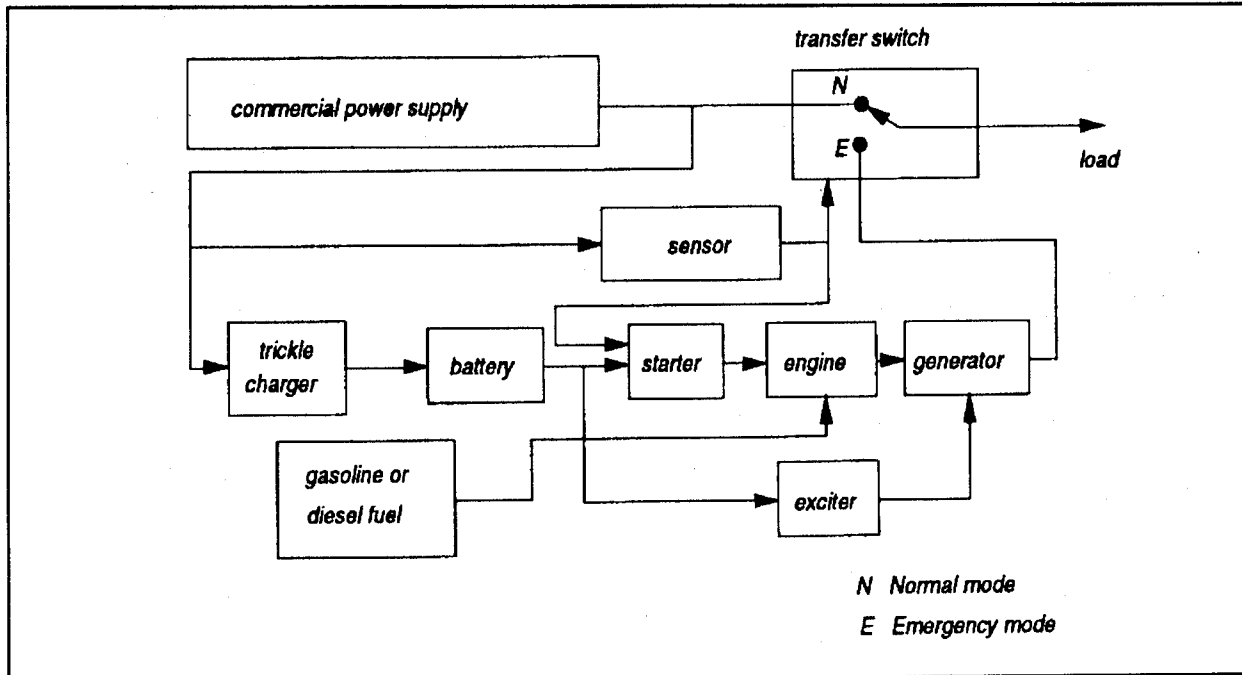

Figure 1. Rotating uninterruptible power supply using diesel- or gasoline-powered generator.

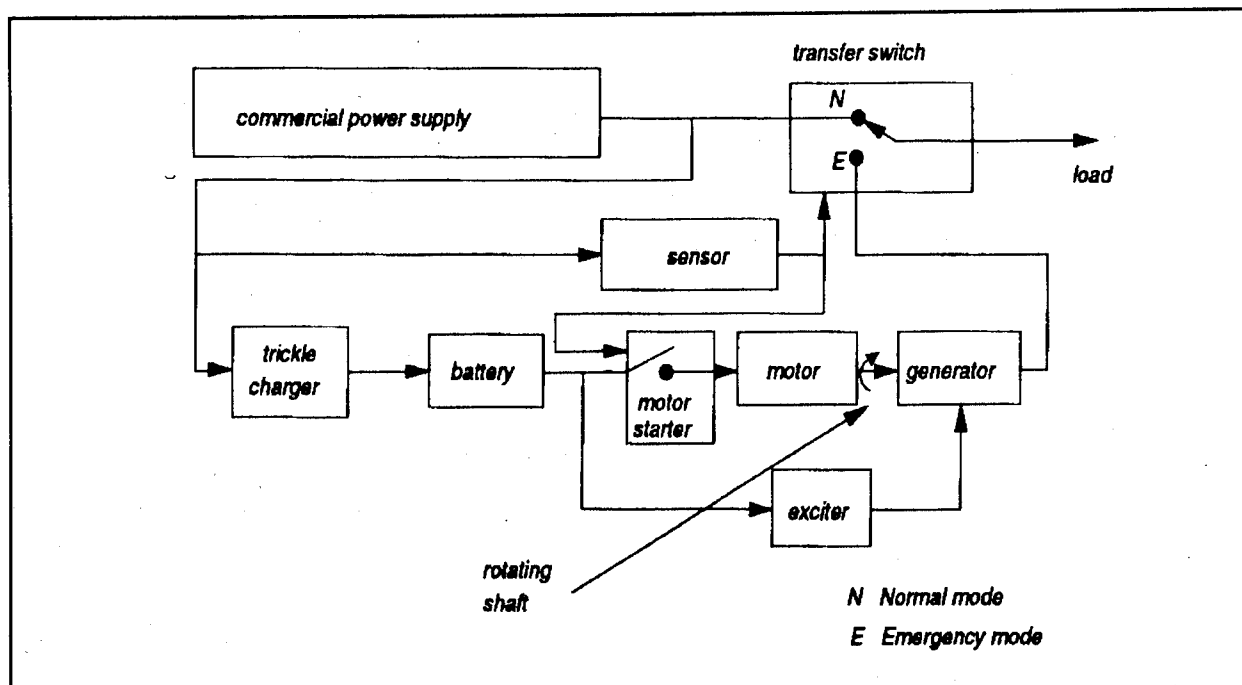

Figure 2. Rotating uninterruptible power supply using batteries as the energy storage medium.

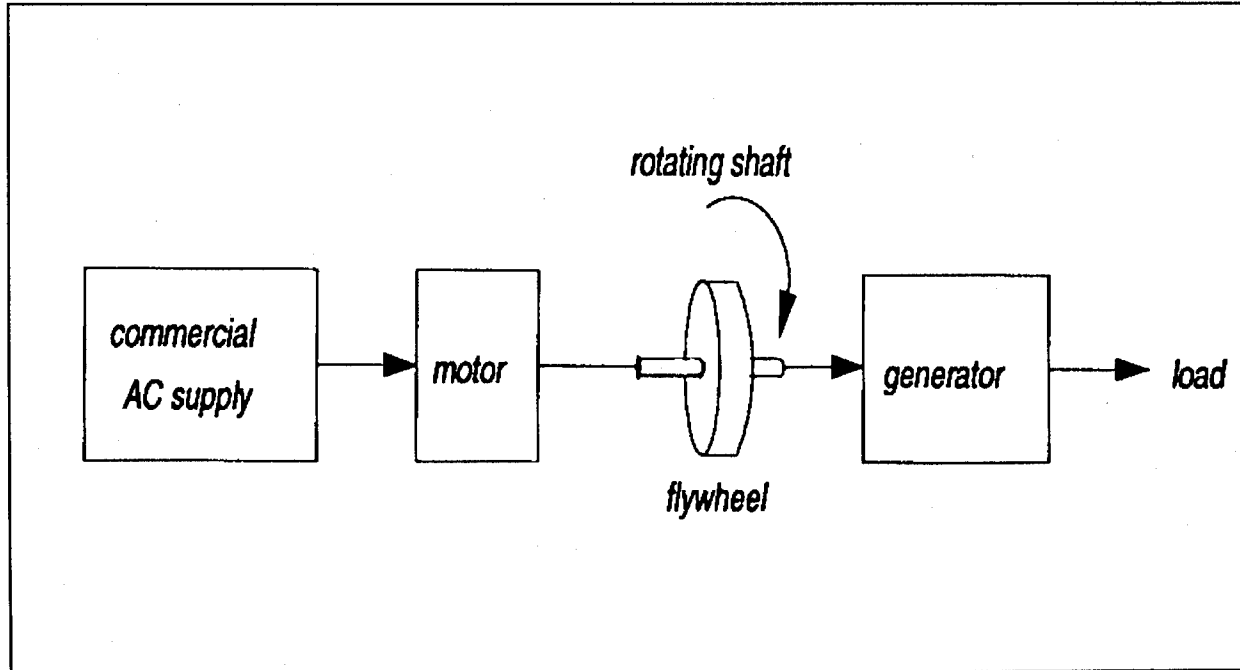

Figure 3. Rotating uninterruptible power supply using a flywheel.

Table 1. Typical power ratings and applications of UPSs.

Size	UPS rating			Typical Applications
	Power	Voltage	Phases	
	kVA	V		
Small	<2.0	120	1	*Personal computers *Small medical equipment *Process controllers
Medium	2.0-20	120/240	1 and 3	*X-ray equipment *Computer-aided tomography scanners *Small computers *Computer auxiliary equipment (communications equipment, LAN and servers)
Large	20-250	240	3	*Mainframe computers *Computer auxiliaries *Communications equipment
Industrial large units	To the MVA range	240/480 and 13.8 kV	3	*Mainframe computers

**Table 2. Main advantages and disadvantages of a rotating uninterruptible power supply.**

Parameter	Advantage	Disadvantage
Isolation	Excellent isolation from the supply for power quality problems of momentary duration	
Speed of load transfer		Slow transfer to auxiliary supply, can be several seconds
Maintenance	Maintenance can be done by unskilled persons	Requires periodic maintenance of rotating elements; for fuel-powered units, requires fuel storage and refueling, and startup testing; most units require battery maintenance
Control	Good voltage regulation	Many designs use slow- speed controllers
Reliability	Rugged design gives good reliability when properly maintained	
Weight		Very heavy
Physical size		Large
Electrical size	From 10 kVA to above 1 MVA	Tend to be applicable only for highest power requirements
Load support time	Can extend to hours for battery- and fuel-operated units	A few seconds for flywheel units without fuel-operated engine; load support time depends on fuel supply for diesel- and gasoline-powered units
Availability	Commercially available in the U.S.	Must be shipped by freight transport

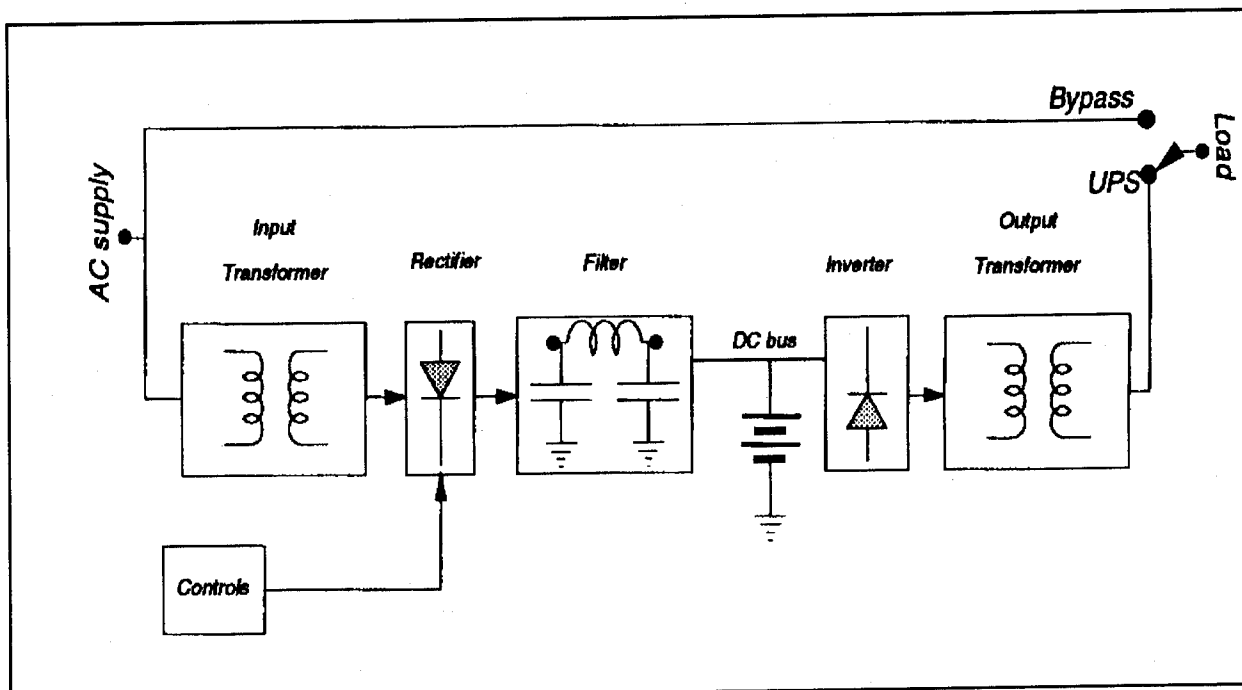

**Figure 4. Static uninterruptible power supply.**

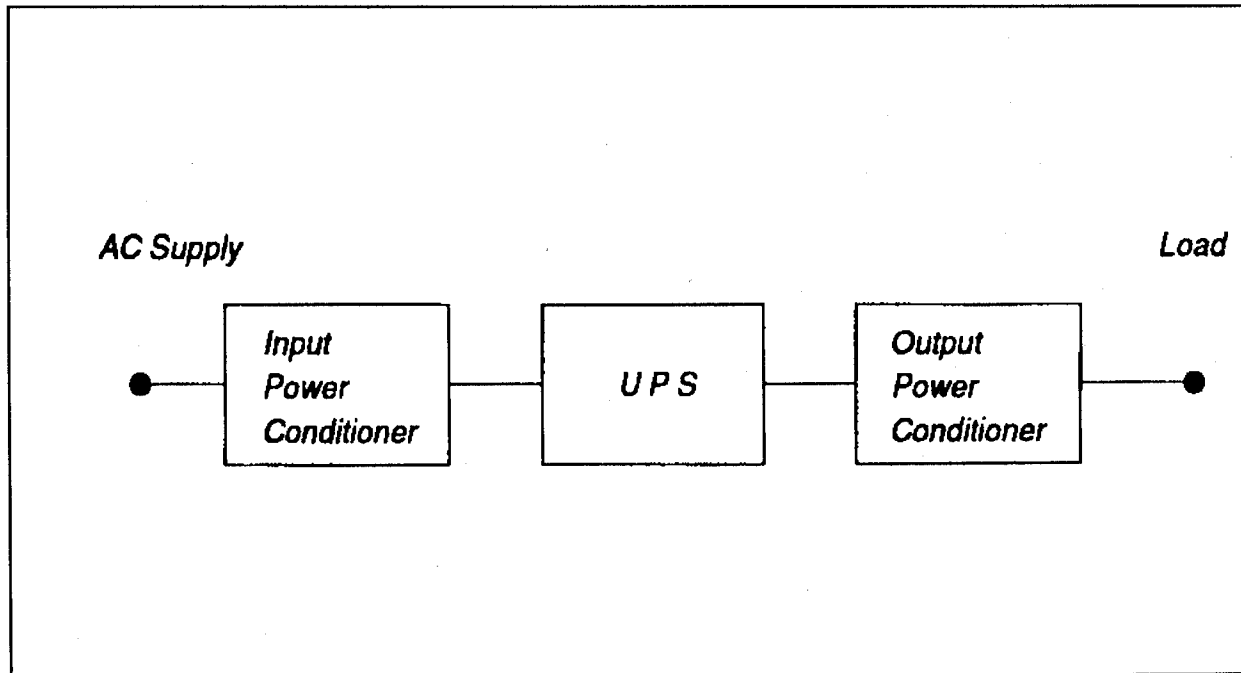

Figure 5. Power conditioners used with a static UPS.

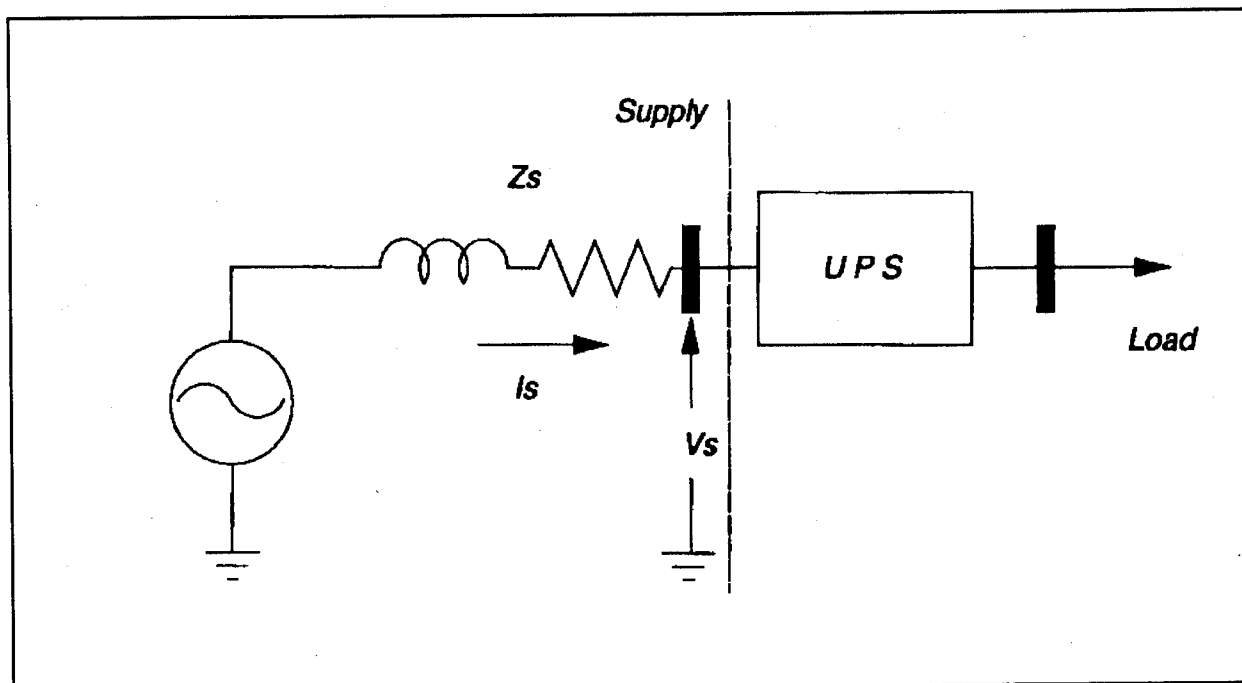

Figure 6. Distortion in supply bus voltage of a UPS due to nonsinusoidal load current.

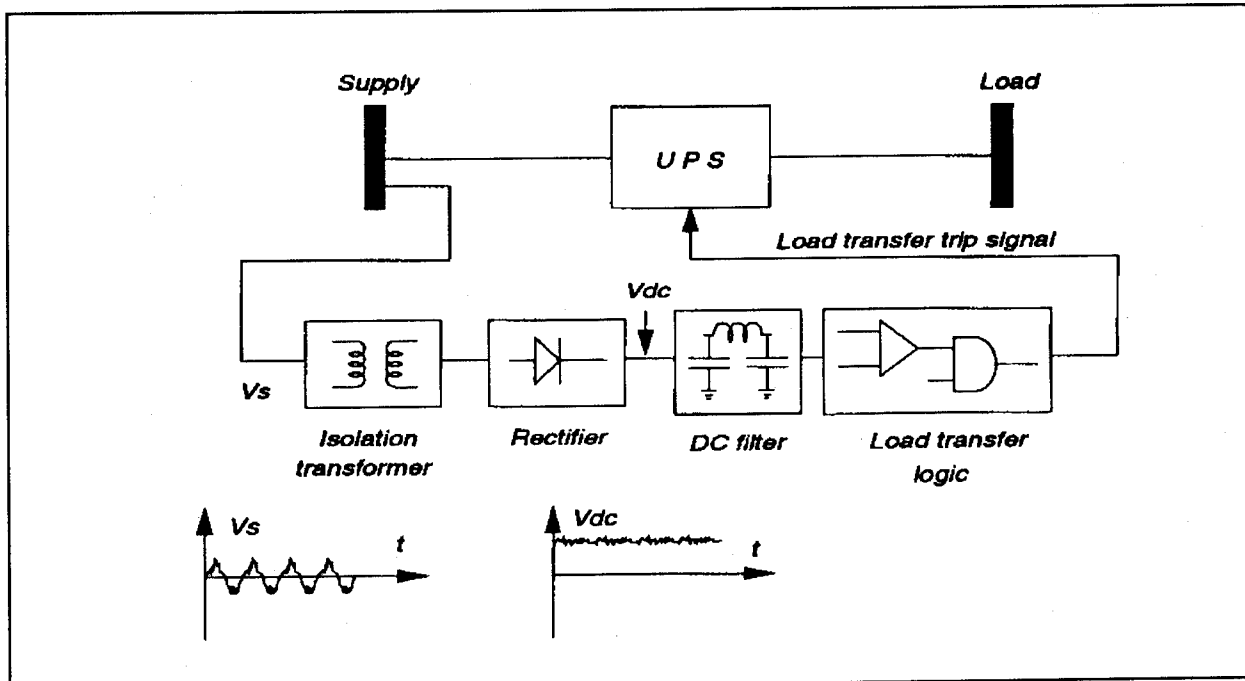

Figure 7. Development of the transfer trip signal in a UPS.

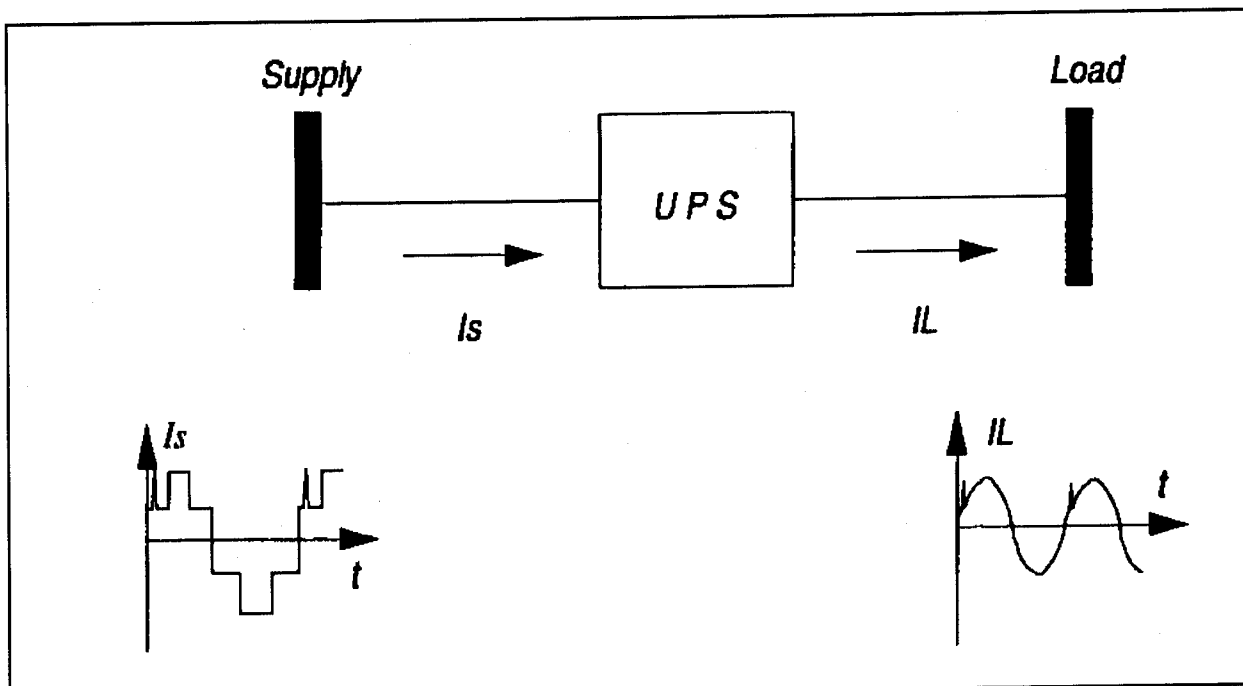

Figure 8. Propagation of load current impulse to the AC supply of a UPS.

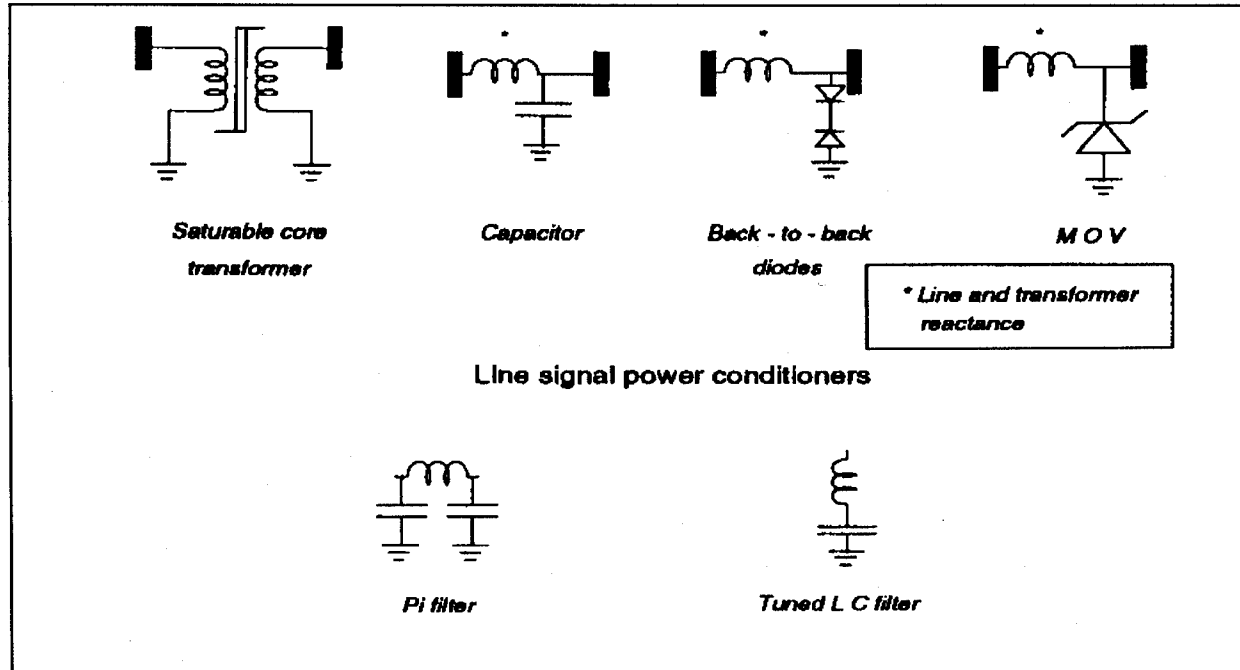

Figure 9. Line-side power conditioners.

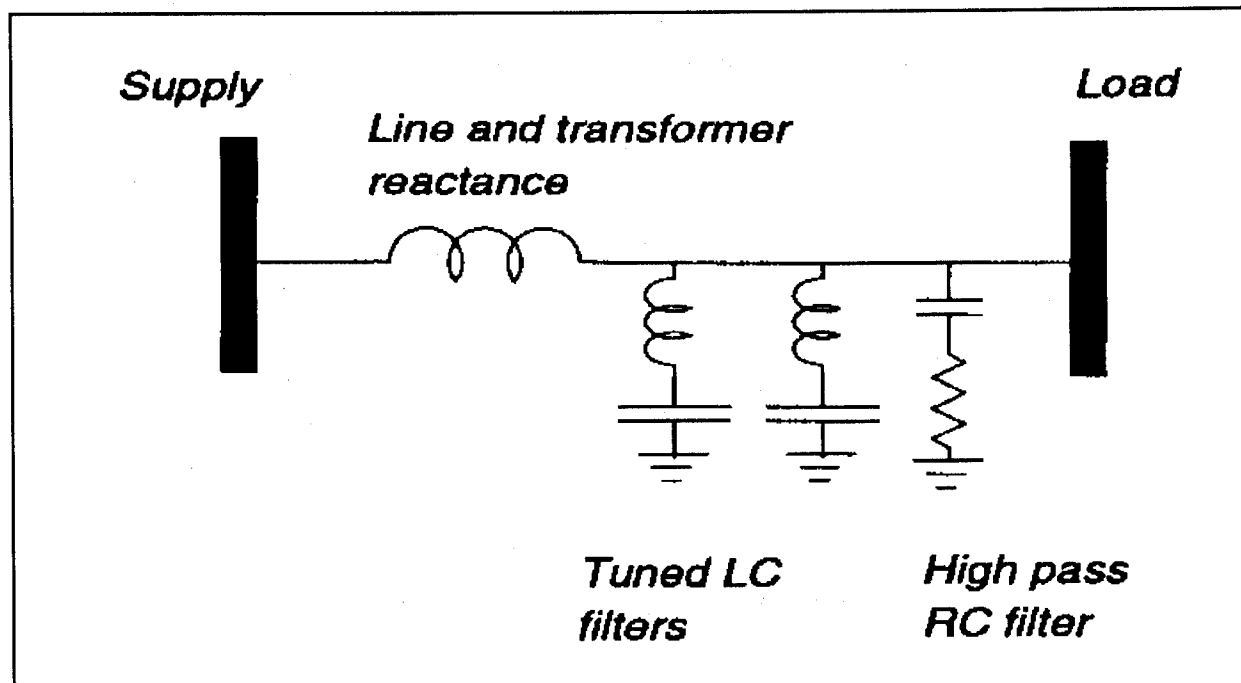

Figure 10. Load-side power conditioners.

### 3 Impact of UPSs on AC Mains

#### UPS as Seen From the AC Supply

The UPS as seen from the AC mains supply is important if the losses, total harmonic distortion (THD), and potential telephone interference in the power distribution line are of interest. Some electric utility companies are examining the possibility of penalizing customers who have high harmonic content in their load current; this can be done because the Institute of Electrical and Electronics Engineers (IEEE) Standard 519 is a consensus code of operating practice. If the customer violates the consensus code, the company may resort to elements in the electric service contract that often include payment of charges associated with violation of the industry-accepted norms. The details depend on the electric utility and the jurisdiction, but it is likely that the regulatory commissions will be sympathetic to the enforcement of industry-adopted standards, in this case IEEE Standard 519.

A UPS often uses power conditioning for normal operation; that is, the AC mains voltage is processed and used to reconstruct a high-quality sine wave for the load. The properties of the power conditioning circuit determine how the UPS is "seen" from the AC supply. In many cases, for static units the power conditioning and the UPS battery charge circuits appear as rectifiers to the AC supply; therefore, for static units single-phase UPSs will have high harmonic load currents as seen from the AC mains. The approximate attenuation of harmonics with increasing harmonic order is  $1/n$  since the Fourier expansion of a square wave has this characteristic. No even-order harmonics appear. An ideal single-phase rectifier with perfect DC output current will have a perfect square wave input load current—hence the  $1/n$  characteristic. For 3-phase units, the phenomenon is similar except that some harmonics are cancelled by the 3-phase connection. For a 6-pulse rectifier, harmonics of order  $6k \pm 1$  will occur ( $k=0, 1, 2, \dots$ ), and the order of these harmonics decreases as  $1/n$  where  $n$  is the harmonic order. For a 12-pulse, 3-phase rectifier, the existing load current harmonics are of order  $12k \pm 1$  and the same  $1/n$  attenuation is observed.

In addition to the cited harmonics resulting from rectifier circuits in static UPSs, there are additional power quality problems that may be passed from the load circuit to the AC mains supply. For example, consider a load that exhibits high pulse demand current with a rapidly rising wave front. Line circuits couple to the load circuits

capacitively due to proximity of the conductors in the UPS, and some coupling through the DC link circuits also occurs. As a result, the pulse demand current also will be seen in the supply current, although greatly attenuated. The absence of coupling between the input and load circuits is called isolation, which is usually measured in decibels (dB).

The foregoing remarks apply primarily to static, solid state, nonrotating UPSs. Rotating UPSs are essentially motor/generator sets with diesel or gasoline engine drives. This type of rotating, mechanical unit has exceptionally high isolation of the supply and load circuits. Diesel- and gasoline-powered UPSs are almost isolated from the AC mains during emergency operation (the only coupling to the AC mains is by electromagnetic coupling of the input and output circuit conductors); during normal operation, the diesel/gasoline-powered UPS is not isolated from the AC mains. Sometimes rotating UPSs are simply motor/generator sets with large rotating shaft inertia (i.e., flywheels). For motor/generator sets fitted with flywheels, the isolation of the supply and load is very high and limited only to voltage supply sags of long duration and high-frequency electromagnetic coupling. Also, the drive motors of motor/generator sets are usually induction or synchronous motors whose AC circuits have been designed for minimum harmonic impact on the AC supply. This is accomplished in a synchronous motor by pole pitch design and winding placement. Usually the lower-order harmonics are cancelled, and the lowest-order harmonic of practical interest is the 11th, which occurs in very low amplitude. Induction motors are similarly designed; the stator current frequency components depend on the rotor slip. Because of this phenomenon, current components at noninteger multiples of 60 Hz will occur in the stator supply. The impact of these motor/generator sets from the power quality point of view, both for synchronous and induction machines, is usually negligible.

### **Isolation of the Supply and Load Circuits**

A secondary function of the UPS is power conditioning, which better serves sensitive loads under a wide variety of often hostile electrical conditions. One way of accomplishing power conditioning is to isolate electrically the load from the AC supply mains. By this means, pulses, sags, spikes, ringing, harmonics, and other power quality problems in the AC mains will be isolated, attenuated, and separated from the load circuit. A second advantage of isolation of the load and the supply circuits is that power electronic and exotic loads often have nonsinusoidal load currents. For example, some common office copier machines have spike demands of current that appear directly on the line supply. Inductive load switching also results in line-side voltage spikes. These load currents can have a harmful effect in the AC distribution secondary

circuits: impulse voltages may damage electronic components, cause spurious operation of controls, and communications may be degraded. For these reasons, it is appropriate to isolate the load from the AC supply to eliminate or attenuate the cited effects.

In general, isolation is measured in decibels,

$$A = 10 \log_{10} \frac{V_{\text{supply}}}{V_{\text{source}}} \quad [\text{Eq 1}]$$

In this expression,  $A$  is the isolation expressed in decibels, and  $V_{\text{supply}}/V_{\text{source}}$  is the ratio of the voltage amplitudes of impulses, harmonics, and other power quality problems in the AC supply mains to the load (source) circuit. Of course, the ratio  $V_{\text{supply}}/V_{\text{source}}$  is smaller than 1, and  $A$  is a negative quantity. Typical isolations are shown in Table 3.

Isolation in a UPS is accomplished in several ways:

- Through the use of a rotating connection between the source and the load (for a diesel-powered rotary UPS operating in emergency mode, and for flywheel-type motor/generator sets)
- Using line suppressors and line filters in the AC mains circuits
- Using line suppressors and line filters in the load circuits
- Using filtering in the DC link between the AC mains and load circuits (static UPSs)
- Using electromagnetic shielding between the supply and load circuits (especially effective for radio frequency interference [RFI] and electromagnetic interference [EMI])
- Physically isolating the supply and load conductors
- Using active (electronic) filters.

The most effective of these means is the use of a rotary connection between the supply and load circuits—that is, a rotary UPS operating in the emergency mode or a motor/generator set. For these rotary UPSs, isolations of -60 dB and greater are attainable. The question is whether the other disadvantages of rotary UPSs (size, shipping, maintenance, weight, and noise) are warranted by the isolation attained. Well-designed static UPSs can achieve greater than -30 dB isolation, and some manufacturers aiming at the radio frequency (high-frequency communications) application markets claim greater than -40 dB isolation at radio frequencies. At least one manufacturer has used shielding and a variety of the electronic measures outlined previously for the purpose of providing isolation for RFI and EMI.

It should be noted that isolation is a function of frequency. For example, even a rotary UPS has some coupling between the mains and the load; for a very low frequency oscillation of 0.01 Hz in the supply, the rotary UPS may pass oscillations on to the load. On the other hand, the RFI isolation of a rotary UPS is great—possibly greater than -60 dB. For static converters, the low frequency isolation is generally poor and near 0 dB. If the UPS is well designed and intended to isolate the supply and the load, the radio frequency isolation may well be in the -30 to -50 dB range. Figure 11 shows typical isolation characteristics of rotary and static UPSs.

**Table 3. Isolation of load and AC supply circuits.**

Isolation in dB	Degree of Isolation
0 to -10	Poor
-10 to -20	Fair
-20 to -30	Good
Greater than -30dB	Very good

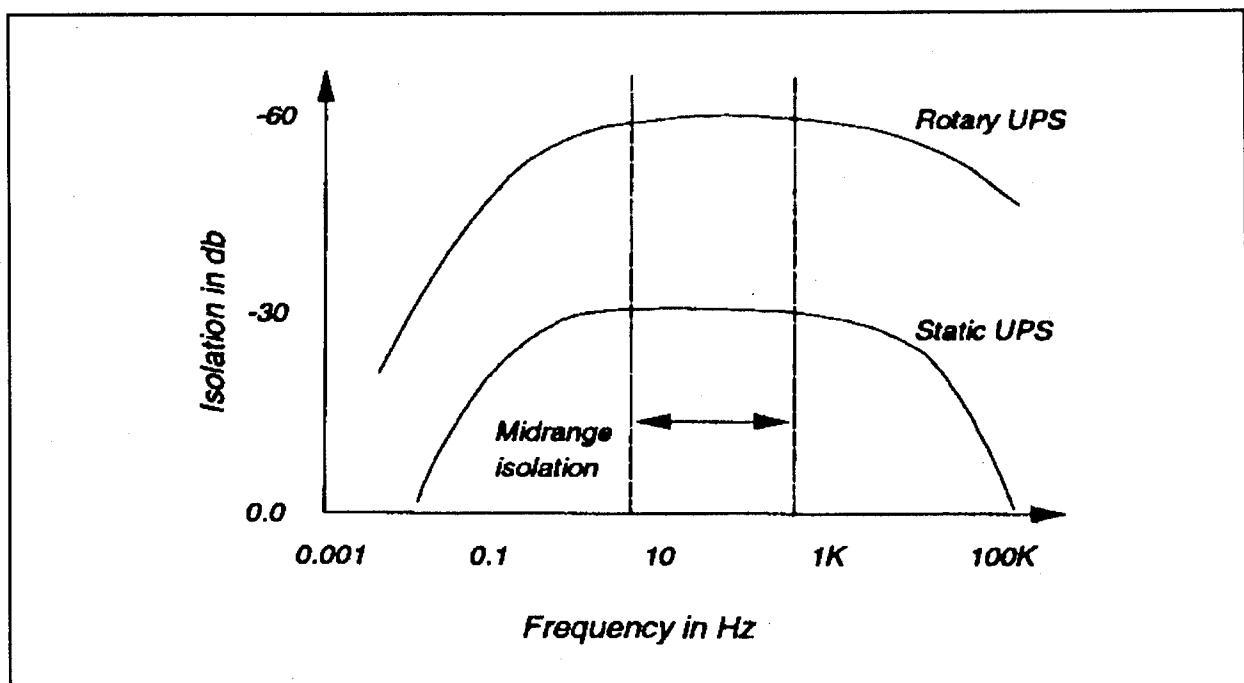

**Figure 11. Typical isolation characteristics of static and rotary UPSs.**

## 4 Underwriters' Laboratories, Military, and Other Specifications for UPSs

### General

Many components in electric power systems for civilian and military use, for transmission and distribution power levels, and for industrial, commercial, or industrial use are described in documents known as specifications. These specifications come from a variety of sources, the best known being:

- American National Standards Institute (ANSI)
- British National Standard (BNS or BS)
- Construction Specifications Institute (CSI)
- Electrical Generating Systems Association (EGSA)
- European Norm (EN)
- Institute of Electrical and Electronics Engineers (IEEE)
- International Electrotechnical Commission (IEC)
- Military specifications (Mil-specs)
- National Fire Protection Association (NFPA)
- Underwriters' Laboratories (UL).

Virtually all power system components of the commercial and industrial class are described in one or more specifications. These include transformers and other electromagnetic devices, circuit breakers, instrumentation transformers and related equipment, insulators and bushings, switches, converters, reactors, capacitors, rotating machinery, fuses, protective relays, and electric power utilization equipment. At the lower power levels, however, there are fewer standards, and these are largely relegated to commonly used appliances or their components. In some cases there are multiple, conflicting standards. Recently, however, the trend has been to consolidate and coordinate standards so that overlap is minimal and conflict between standards does not occur. To further complicate the situation, some standards are written with a special scope and purpose. For example, the European standards for electrical equipment come from the IEC in Geneva, Switzerland, but the United States is not generally a signatory of IEC standards. The Mil-specs generally are not used in civilian sectors, and the construction trade organization standards (e.g., CSI) are not commonly cited in manufacturing and electric utility applications. The reason for conflicting standards is largely historical: the trade and governmental organizations

have evolved their own standards and have not always coordinated among themselves the writing of those standards. Also, needs and objectives vary among the different standards agencies: for example, what may apply in the civilian sector may be inappropriate in the military sector. Many recently issued standards have been adopted by several agencies and these carry multiple designators (e.g., ANSI/UL Standard 1778-1991, "Uninterruptible Power Supply Equipment").

There is a single standard for uninterruptible power supplies: ANSI/UL Standard 1778-1991, "Uninterruptible Power Supply Equipment." Related standards include:

- ANSI/UL Standard 1012-1984, "Power Supplies," an older standard that has been updated and reassembled into UL 1778-1991. UL/ANSI Standard 1012-1984 deals with all types of low power-level power supplies, generally in the 10 kVA class and smaller. The main concerns of UL/ANSI Standard 1012-1984 are safety and fire hazards.
- Construction Specification Institute (CSI) Standard 16612-90, "Emergency Generating Equipment," includes equipment intended for long-term service to temporary loads.
- EGSA Standard 101S, "Engine Driven Generator Sets Guideline Specifications for Emergency Standby." This standard focuses on gasoline-driven engines, fire hazards, and emergency power applications.

A variety of other generic codes and standards deal with all electrical equipment connected to AC distribution busses; these standards focus on safety, fire hazards, and protection of personnel.

There are presently no military specifications for uninterruptible power supplies. The only military specification for electric power supplies is for specialized power used in medical applications (cautery units).

### **Underwriters' Laboratories Specification UL 1778**

The Underwriters' Laboratories Specification UL 1778-1991, "Uninterruptible Power Supply Equipment," was approved in August 1991 and is dually listed by ANSI as ANSI/UL 1778-1991. The standard applies to UPSs rated at 600 V or less and applies only to units serving loads in accordance with the National Electrical Code (NFPA 70). The main concerns of UL 1778-1991 are safety, fire hazards, temperature of operation, placards and markings, ventilation, protection, and mechanical specifications. The standard deemphasizes electrical parameters, and no mention is made of load current

harmonics, nonlinear loads, or related areas. The safety sections of UL 1778-1991 include shock hazards.

The only section of UL 1778-1991 relevant to electrical testing is the section dealing with UPS temperature rise. The maximum surface temperatures of UPSs as stated in the standard are shown in Table 4. The UL 1778-1991 standard also gives the fuse sizing for UPSs, maximum leakage current for safety grounds, and battery safety requirements.

### Other Specifications

The only secondary specification that closely relates to uninterruptible power supplies is ANSI/UL Standard 1012-1984. This older standard has been largely updated and revised and assimilated into ANSI/UL 1778-1991. The main elements of ANSI/UL 1012-1984 are:

- Safety and injury to persons
- Fire hazard
- Overload response
- Overcurrent response
- Overvoltage response
- Mechanical specifications, susceptibility to vibration and mechanical impact
- Physical size and integrity
- Operating temperature
- Warning placards and standardized markings
- Applicability to general power supplies in the 10 kVA class and smaller.

**Table 4. Maximum surface temperatures of UPS cabinets and equipment according to UL 1778.**

Location	Composition	
	Metal	Nonmetal
Handles or knobs intended for lifting or carrying	50 °C	60 °C
Handles or knobs that are contacted but are not intended for carrying	60 °C	85 °C
Surfaces subject to casual contact	70 °C	95 °C

## 5 Electrical Tests for the Susceptibility of UPSs to Harmonics and Other Power Quality Problems

### Electrical Characteristics To Be Tested

The main power quality problems for which UPSs might be tested are listed in Table 5. These problems represent the most commonly encountered line and load current and voltage problems. The elements listed in this table are discussed in this chapter and tests for each type of power quality problem are described.

It is important to note that the tests described in this report are not standard; considerable care should be taken when making the experimental measurements and laboratory connections. The following are the main hazards that are highlighted because of the importance of laboratory safety:

- The UPS loads will heat to high temperatures, so care should be taken to avoid fire and burns.
- The impulse tests described later use capacitors to store energies in the 50 joules (J) range. Charged capacitors are a shock hazard that may hold a charge and present a hazard minutes after the test set is deenergized.
- Several of the tests may be done with breadboard-constructed circuits. Because these circuits are energized to line potential without isolation, there is a shock hazard.
- Several of the tests use high-power resistors that may be energized to line potential; therefore, the exposed metal parts of the resistors and the resistive wire element may be a shock hazard and a fire hazard.
- Only persons qualified in laboratory measurement techniques and distribution power engineering should perform these tests.

## A Test Set To Produce Harmonics in the Load Current

There are several ways to load a UPS with a harmonic load current. These include:

- Using an adjustable speed drive as a load
- Using a silicon-controlled rectifier (SCR)-switched load
- Using a triac-switched load
- Using a power amplifier driven by a signal generator. The output of the generator is connected to the UPS load terminals through an inductor.

Of these methods, the triac-switched load gives the best control of harmonic levels, from zero THD to a very high level of distortion. Figure 12 shows a typical configuration as it would be used to test a UPS. Table 6 shows circuit values depending on the maximum power level of operation and supply voltage.

The THD of the load is controlled by varying the phase shift network shown in Figure 12. The load applied to the UPS is controllable by varying the load resistance as shown in the circuit diagram.

The test set shown in Figure 12 should be used to test for the susceptibility of the UPS to transfer load under cases of high load current THD. Also, the test set may be used to test for susceptibility to heating of the UPS.

The harmonic analyzer shown in Figure 12 may be any one of a number of signal analyzer units now commercially available. The following is a sampling of units that are suitable for the task:

- BMI 8080
- BMI 3030
- BMI 3030A
- Dranetz 656
- Angus Electronics PHD analyzer.

Note: These instruments are usable only if the usual low-order harmonics of 60 Hz are to be instrumented. The BMI and Dranetz instruments are usable to about 3 kilohertz (kHz), and the lower-cost Angus instrument to 780 Hz. In many applications, these frequency limits are acceptable. The price range (1993) for the BMI and Dranetz instruments is \$15,000 and about half that figure for the Angus instrument. For pulse modulated designs of either UPSs or loads, it is not unusual to find modulating frequencies into the 20 kHz range, for which the instruments previously listed will be inadequate. For testing of such units a wideband spectrum analyzer is recommended.

## Test for Susceptibility of Load Transfer Time to Harmonic Load Currents

Using the load current THD test set shown in Figure 12, UPSs may be tested for susceptibility of degradation of load transfer time due to harmonics in the load current. This is done by measuring the time required to transfer load to the emergency supply upon outage or voltage drop of the main line supply voltage. This is done for different load current THDs.

Some UPSs are designed for zero load-transfer time; that is, the output voltage of the UPS is derived from the inversion of a DC bus that is battery supported. Upon loss of the AC mains, the load bus voltage is automatically retained because it is derived from a fixed source. In these cases, the load transfer time is zero, independent of load characteristics.

Table 7 shows the data sheet for this series of tests, and Figure 13 shows the test set for producing a low-voltage condition at the supply side of the UPS. Table 8 shows component values and ratings for the low-voltage test set depicted in Figure 13. The procedure for testing the susceptibility of UPSs to transfer load under harmonic load currents is:

1. Adjust the load current firing angle control to produce zero THD (i.e., purely resistive load). Record the load current THD and load current active and reactive power.
2. The purpose of this test is to measure the time required for the UPS to identify the low-voltage condition and transfer the load to the UPS source. The low-voltage condition is produced using the test set shown in Figure 13. As such, the onset of low voltage is controlled and known. However, the laboratory test must include an identification of the time that the UPS transfers the load to the UPS source. This may be accomplished in one of three ways. The first and most reliable is through the use of a UPS internal signal that indicates the load has been transferred from the commercial AC line to the UPS (in many UPSs there is an indicator light that shows the load status). The indicator shows that the load is supported by the AC line or the UPS. If this indicator is available, the signal that activates the indicator lamp may be accessed by removing the indicator panel and applying an oscilloscope input from the indicator lamp itself. The oscilloscope should be a dual trace unit with the remaining input from the AC mains. In this way the two traces, the UPS load status lamp and the AC supply, are used to time the transfer of the load from the commercial to the UPS supply.

The second technique is termed the low-voltage technique and is appropriate if the UPS is not fitted with a load status indicator. In this technique, the UPS

load voltage is monitored and as the supply is lowered, the load voltage will also drop. When the load is transferred to the UPS source, the load voltage amplitude will no longer drop, but will remain at a fixed level. This technique is discussed later.

The third technique is the least accurate of the three methods and should be used only if no UPS load status indicator is available and if the voltage regulator in the UPS precludes the low-voltage technique just described. In this third technique, the UPS input and output voltages are monitored with a dual-trace oscilloscope and the supply voltage is lowered. The loss of AC supply voltage is determined from the supply voltage trace, and output of the UPS may exhibit a momentary loss of voltage. The recovery of the load voltage is identified from the load voltage trace. Keep in mind that the intended function of the UPS is to keep the load voltage uninterrupted; therefore, for an ideal voltage-regulated UPS, the load voltage may not show any indication of load transfer. In these cases, the load transfer time is zero, and if the load transfer time remains zero as the load current THD is increased, the UPS is well designed and is truly an uninterruptible power supply.

3. The low-voltage technique for identifying the load transfer point is further described as follows: set the supply voltage drop control in the test set of Figure 13 to 90 percent of the supply voltage. "Fire" the low-voltage test set, thus triggering the oscilloscope, and record the UPS output voltage. The output voltage of the UPS will show the transfer time of the UPS as shown in Figure 14. If the UPS has a load transfer indicator, this signal should be used to identify the load transfer point.
4. Change the load current firing angle control to produce approximately 10 percent load current THD and repeat the load transfer time test. Repeat for progressively higher load current THD values until the maximum load current THD has been reached.
5. Reset the load current THD control to zero THD and retest the UPS transfer time for an 80 percent low-voltage condition. Repeat the test for 10 percent and higher values of load current THD.
6. Reset the load current THD control to zero THD and retest the UPS transfer time for a 70 percent of nominal low-voltage condition. Repeat the test for 10 percent and higher values of load current THD. Repeat the testing at 60, 50, 25, and 0 percent low-voltage conditions.
7. The columns of Table 7 are explained as follows:
  - A Run number or test number for identification purposes
  - B Supply voltage drop in percent of the rated line voltage:  $(V_{\text{rated}} - V_{\text{under load}})/V_{\text{rated}}$
  - C Load current THD in percent as read from a signal analyzer in the load current circuit

- D** Active power (watts or kilowatts) and reactive power (vars or kilovars) as measured in the load circuit. Also, the load power factor and a notation of leading or lagging power factor.
- E** Time required to transfer load to the emergency supply as measured from a triggered oscilloscope, expressed either in seconds or cycles (cycles =  $60t_{\text{seconds}}$ )
- F** Additional observations such as failure to transfer load, UPS heats, load erratic, load not stabilized.

The susceptibility of the UPS load transfer time to load current harmonics is evaluated by examining the transfer time characteristic (see Figure 15) for different values of load current THD. The characteristic in Figure 15 shows the usual increase of speed of transfer versus decrease of supply-side bus voltage. If the characteristic is appreciably degraded (i.e., transfer time lengthened) as the load current THD increases, the UPS is deemed susceptible in transfer time to load current harmonics. Table 9 shows a qualitative evaluation.

### Test of UPS Efficiency Under Harmonic Load Current

In this test, the efficiency of the UPS is tested while it is loaded with a nonlinear load. The efficiency is defined as

$$\eta = \frac{P_{\text{load}}}{P_{\text{input}}} \quad [\text{Eq 3}]$$

The main source of losses in the UPS are transformers and semiconductor switching. If the UPS has cooling fans, resistive line suppressors, panel lamps, and certain other devices, these also will contribute to the loss. The greatest losses occur in the transformers. Transformer losses are highly dependent on load current amplitude. For this reason, the power factor of the load is a sensitive factor in determining the UPS losses, and hence the efficiency.

The basic test configuration for evaluating UPS efficiency is shown in Figure 16. In this test configuration, the input and output power of the UPS are measured simultaneously. The efficiency is the ratio of these measured powers. Because the efficiency is a function of the load power factor, provision is made in Figure 16 for adjusting the load power factor. This is done by switching capacitors C, 2C, and 4C (thereby giving a range of total capacitance from zero to 7C). The capacitors are reshunted by resistors to reduce shock hazard after the device has been deenergized. The capacitance values for this test are shown in Table 10.

The efficiency measurement tests are best performed over as wide a range of harmonics as possible because the efficiency will vary over that range enough to be measured. It is important to hold the power factor constant over these tests to eliminate this variable from determination of the efficiency. A procedure for this test is:

1. Load the UPS to maximum with a purely linear load (i.e., no distortion from the nonlinear load) and unity power factor. Record the input (line side) and output power (load side) of the UPS and calculate the efficiency.
2. Change the load by increasing the load distortion using the triac-switched load. Using the power factor correction capacitors if needed, set the capacitors to give as close to unity power factor as possible. Again, record the input and output power to the UPS and calculate the efficiency.
3. Repeat this process for several (at least three) load levels.

A data sheet for this test is shown in Table 11 where the columns are:

- A** Run number for identification.
- B** The supply (line side) voltage and current amplitude. If using a measurement instrument such as the BMI 3030 or BMI 8080, these quantities will be recorded automatically.
- C** The output (load side) voltage and current amplitude. If using a measurement instrument such as the BMI 3030 or BMI 8080, these quantities will be recorded automatically.
- D** The line-side active, reactive, and apparent power. Also, the true power factor on the line side (calculated from real power/apparent power [P/S]).
- E** The load-side active, reactive, and apparent power. Also the true power factor on the load side (calculated from [P/S]).
- F** The load current THD.
- G** The UPS efficiency is calculated from output power divided by input power, often represented as a percentage.
- H** Additional observations as deemed necessary.

The expected results of the efficiency test are that the efficiency should decrease with increasing load current THD (for fixed power factor). This is due to the additional transformer losses incurred at high THD levels. Figure 17 shows a typical result. In the figure, the vertical scale is unlabeled since UPS efficiency is dependent on the model, mode of operation, and unit design. Typical UPS efficiency figures are in the range of 70 to 85 percent for small UPSs (e.g., 1000 VA and smaller), and 80 to 95 percent for higher capacity units. Table 12 shows a qualitative assessment of the efficiency of the UPS units. To assess the test results for efficiency under high

harmonic current, for example 20 percent current THD, this table is recommended for static UPSs. Rotating UPSs are generally rated above 10 kVA and the overall efficiency of a typical motor generator set is 81 to 87 percent at full load. Lossy and low loss units may be identified relative to this figure.

### **Test for Susceptibility of UPS Heating Due to Harmonic Load Currents**

In this test the heating of a UPS under nonlinear load is studied. This test is essentially the same as the test of UPS efficiency described earlier, except that the heating effect of the losses is evaluated by using an infrared videocamera to measure the internal heating of the UPS. The test procedure is:

1. Remove the cover of the UPS case to reveal the main power transformer and main semiconductor components.
2. Load the UPS to maximum (rated) with a purely linear load (i.e., no distortion from the nonlinear load) and unity power factor. Record the input (line side) and output power (load side) of the UPS. Use considerable caution to avoid electrical shock: with the UPS cover removed, the unit may present considerably more shock hazard than when fully assembled.
3. Allow the rated load to be applied to the UPS for approximately 2 hours to stabilize the thermal state of the unit. View the interior of the UPS with an infrared videocamera. It is expected that the semiconductors, power resistors, and transformers will reach the highest temperatures. Record the highest (hotspot) temperatures.
4. Change the load by increasing the load distortion using the triac-switched load. Using the power factor correction capacitors if needed, set the capacitors to give as close to unity power factor as possible. Again, record the input and output power to the UPS and allow the UPS to stabilize its thermal state. View the interior of the UPS with an infrared videocamera and record the hotspot temperatures.
5. Repeat this process for several (at least three) load levels.

The interior temperatures of most electronic devices can go to at least 70 to 95 °C without damage, loss of life, or safety hazard. The test results may be qualitatively evaluated using the UL 1778-1991 criterion of allowing no more than 95 °C temperature for nonmetallic components and 70 °C for metallic components. Table 4 shows the UL 1778-1991 maximum temperatures for UPSs. Measured temperatures of the UPS under full load and 20 percent load current THD should be assessed according to Table 13.

## Test for Degradation of Load Support Longevity to Harmonic Load Currents

The main function of a UPS is to support the load when the AC mains supply fails. The length of time for which the load may be supported is termed the longevity of the load support. The longevity is generally measured in minutes for small UPSs, and is directly proportional to the energy content of the internal battery supply.

In this test the longevity of the load support is measured. This is done for the UPS for differing harmonic load currents. Figure 18 illustrates the test. The load is a suitable nonlinear load such as the triac load test set shown in Figure 12. The longevity is the time for which the load is supported:

[Eq 3]

$$T_{\text{longevity}} = T_{\text{UPS fails}} - T_{\text{load fails}}$$

The longevity test should be done at full UPS load and unity power factor; therefore, a power factor correction test set is included in Figure 18. It will be difficult to obtain perfect power factor correction in this test while full load is retained because there are too many variables specified and too few degrees of freedom. For this reason it is important to record the power factor and load accurately so that the energy supplied to the load is calculable. If an instrument such as a BMI 3030A Power Analyzer is used, the load versus time will be recorded and may be recovered from the instrument disc. If the BMI 3030A is used, an accurate measurement of the load voltampere hours is attainable.

The load longevity test is as follows:

1. Using the test set of Figure 18, load the UPS to rated value and set the triac harmonic source so that there is no distortion of the sine wave. This is the linear load case (zero THD). Interrupt the supply and record the time for which the load is supported. A suitable data sheet is shown in Table 14.
2. Allow the UPS to recharge after the test just described is completed. The recharge time varies from unit to unit, but it is likely to be several hours. Alternatively, replace the UPS batteries with fully recharged units and record the recharge time. Repeat the zero THD case several times, allowing full recharge between tests. The repetition of the test several times (five is suggested) is done to eliminate statistical errors due to load variation, recharge time difference, UPS heating, and other sources of error.
3. Repeat the test for intermediate load current THD (e.g., 20 percent) at a maximum power factor using the triac test set. This power factor will depend on the exact nature of the load and the UPS output impedance, and will be in the

range of 75 percent lagging for 20 percent THD. The longevity test at 20 percent THD is repeated several times as before.

4. The test is repeated for high-load current THD. This should be done at a maximum THD from the triac test set (e.g., about 50 percent THD).
5. Review the test data and determine whether intermediate tests should be run. If the longevity times and energy support levels do not show any clear trends, it may be worthwhile to run additional exemplars of the tests already run. If the longevity trends are complex and show wide variation, one or more intermediate THDs may be used to obtain a better estimate of the trends. The expected trend is shown in Figure 19.
6. If test results still appear erratic, it may be worthwhile to run several tests for a purely linear load, testing the longevity of support for different power factors. Because of fewer variables in this test, less disperse results are expected. Figure 20 shows expected results.

When interpreting the results of longevity tests, it is important to examine the energy supplied to the load during the period for which the load is supported by the UPS. The load support energy is the integral of the load power over the load support period,

$$W_{support} = \int_T^0 p(t) dt \quad [\text{Eq 4}]$$

In this expression,  $T$  is the period for which the UPS supports the load. In most practical cases, for constant load  $W_{support}$  is simply  $PT$  where  $P$  is the active power load in watts,  $T$  is the support time in seconds, and  $W_{support}$  is the supported energy in joules. Note that

- 1 watt-second = 1 joule
- 1 watt-minute = 60 joules
- 1 watt-hour = 3600 joules
- 1 kilowatt-hour = 3,600,000 joules.

The true comparison of UPS response under harmonic loading should be done using the support energy. As the load current THD rises or the load current power factor drops, the UPS efficiency will decrease and the support energy available will probably decrease. If the support energy is fairly constant over a wide range of load conditions, the UPS is a low-loss unit. If the support energy drops sharply with higher load current THD (or lower load power factor), the UPS is relatively lossy.

The load support time depends on the battery size and losses in the UPS. Under nonlinear load, the losses will be greater than under zero load current THD load. An approximate expression for the multiplying factor for the losses in the UPS is

$$\sqrt{1 + THD^2} \quad [\text{Eq 5}]$$

If the zero load current THD efficiency of the UPS is  $\eta$ , then it is expected that the degradation (lowering) of the load support time under a specified load current THD will be

$$\frac{1 - \eta \sqrt{1 + THD^2}}{1 - \eta} \quad [\text{Eq 6}]$$

The actual degradation depends on  $\eta$ , but a typical characteristic is shown in Figure 21.

### **Test for Susceptibility of Output Bus Voltage Regulation and Harmonic Content Due to Harmonic Load Currents**

In this test the stiffness of the output bus voltage of the UPS is tested. The term stiffness refers to the ability of the UPS to act as a perfect voltage source (an infinite bus). For an ideal voltage source, the bus voltage will be sinusoidal no matter what the load current may be (see Figure 22). For actual voltage sources (the UPS has internal resistance and inductance due to the realization of the inverter in the UPS, its transformers, semiconductor bulk resistance, battery resistance, and other factors), the impedance depicted in Figure 23 results in nonsinusoidal bus voltage and potentially poor voltage regulation.

The basis of this test is shown in Figure 24. The UPS load is a nonlinear load such as the triac load of Figure 12, and as the load is varied, the load bus voltage and spectrum is measured. For an ideal UPS, the bus voltage regulation will not change as the load is varied from zero to full load. Also, the spectrum of the bus voltage will remain essentially that of the fundamental frequency and its THD will remain low (e.g., below 5 percent). There is no standard that limits the bus voltage harmonic distortion; however, using the harmonic distortion limits of distribution bus voltages (5 percent or below) from IEEE Standard 519, a conservative criterion is applied.

The test is described as follows:

1. Connect the UPS with a suitable nonlinear load such as the triac nonlinear load of Figure 12. With the load disconnected, record the AC mains root-mean-square (RMS) voltage, its harmonic spectrum and voltage THD, and the same elements on the load side. A suitable data sheet is shown in Table 15. It may also be desirable to record line-side and load-side voltamperes, line current THD, and line current spectrum (not shown in Table 15).
2. Calculate the bus voltage regulation,

$$R = \frac{|V_{rated}| - |V_{load}|}{|V_{rated}|} \quad [\text{Eq 7}]$$

In this expression  $R$  is the voltage regulation (often expressed in percent as  $100R$ ) and the load voltage amplitude is the measured load-side voltage in volts RMS. It may be convenient to enter  $R$  in a column of its own in Table 15.

3. Repeat the foregoing test at approximately 50, 75, 90, and 100 percent rated load power. Use the triac controls to obtain these power levels and thereby create different levels of load current distortion.
4. Depending on the manufacturer's recommendation, the cooling used, and the load available, it may also be desirable to test the regulation of the UPS to 125 percent.

The expected results of this test are the identification of the UPS voltage regulation and load voltage distortion characteristics. In Figure 25, two typical voltage regulation characteristics are shown: decreased line voltage at the AC supply (i.e., the line voltage regulation characteristic) and the UPS output voltage (UPS load voltage characteristic). The line voltage regulation results from increasing load current passing through the equivalent impedance of the secondary distribution supply. This regulation, properly attributed to the effects of the commercial distribution power supply, should not be attributed to the UPS. The UPS bus voltage may be of poorer regulation than the supply, which is due to the failure of the UPS to regulate the bus voltage through conditioning in the UPS itself. This is illustrated in Figure 24. Alternatively, the UPS may have internal signal conditioning and the load-side voltage may exhibit better regulation than the line voltage. The proper means of assessing the test results depends on the UPS design (i.e., whether signal conditioning is used in the UPS or not) and the proposed application (whether the line voltage regulation is potentially a problem or not). In any case, the net voltage regulation at the load should be within prescribed limits. There is no standard for voltage regulation, especially when nonlinear loads are used; however, the limits shown in Table 16 are given as a qualitative guide.

## Test for Sensitivity of UPS Load Transfer Voltage Due to Harmonics in the Supply Voltage

This test determines the susceptibility of the UPS to degradation of load transfer to the UPS (i.e., emergency) supply when the line voltage drops and is contaminated with harmonic components. The results of the test indicate whether harmonics in the supply voltage can degrade the detection of a low-voltage condition.

The essence of the test is shown in Figure 26. The components and their functions are:

- The variac is used to raise and lower the supply voltage to compensate for the voltage drop in resistor R.
- Resistor R is used to isolate the supply and the nonlinear load. This will result in contamination of the UPS bus voltage by harmonic components. The larger the R, the greater the voltage drop in R, and the greater the harmonic components of the input voltage to the UPS. The variac is used to compensate for the voltage drop in R.
- Nonlinear load is used to create a harmonic current in the variac and R, which also creates harmonic components in the UPS input voltage.
- Resistor Rx is used to create a voltage drop to trip the UPS to the emergency (UPS source) state.

Figure 27 shows the configuration used in this test. The measurement in this test is, essentially, the measurement of the transfer trip voltages of the UPS when the supply is contaminated by harmonics. Usual lower trip points are 96 volts (V) (for a 120-V UPS, transfer point line to UPS) and 102 V (for a 120-V UPS, transfer point, UPS back to line), and correspondingly 176 V and 187 V for a 220-V UPS and 352 V and 374 V for a 440-V UPS. The main ratings and component values for the test set in Figure 27 are shown in Table 17. The ratings of the variac are shown in Table 18. If a 240-V variac is used, the usual output voltage range is 0 to 270 V. The corresponding output voltage ratings for a 120-V variac are 0 to 135 V. As is clear from the voltage ratings in Table 19, the resistors used in the test should be insulated from their supports and from personnel. These voltage ratings are for shock hazard prevention.

An alternative to the method shown in Figure 27 is to use an iron core choke in place of resistor R. The advantage of this approach is that there will be half the active power used during the test. At power levels in excess of 1 kilowatt (kW), this may be an important factor. However, the cost and availability of an iron core choke to replace R is a clear disadvantage. Further, if the test is done without prolonged operation in the various load configurations, the losses and heat generated may not be a problem.

If an iron core choke is used in place of R, the inductance of the choke (in henries) should be calculated from

$$L = \frac{R}{120\pi} \quad [\text{Eq 8}]$$

The DC current rating of the choke should be at least 2.5 times the maximum (rated) RMS current taken by the UPS (i.e., at 1000 voltamperes (VA), 120 V, the UPS takes 8.33 amperes (A) and the choke rating should be at least 20.8 A RMS—the nearest commercially available value is 30 A DC). The voltage rating of the choke should be those listed in column R of Table 19.

The test proceeds as follows:

1. Using the triac load shown in Figure 12 configured to match the UPS ratings (i.e., for a 250-VA UPS, use a 250-VA triac load), adjust the triac load for zero power and zero THD. Use the triac load as shown in the test set of Figure 27. In this part of the test, the triac load is essentially disconnected and there is no distortion present in the current in R. Let the load resistor (RL) in Figure 27 be that shown in Table 17. With Rx set at zero, set the variac to obtain the rated voltage at the line side of the UPS. Find the voltage trip point of the UPS experimentally by depressing the test switch (S). If the UPS does not transfer load to the UPS source, increase Rx. If the UPS does transfer load, try to decrease Rx. For a 120-V UPS, a trip point of about 96 V is expected (176 V for a 220-V UPS). Record the value of V2 such that the load is transferred to the UPS. Note that there is a shock hazard for R and Rx since both terminals of these resistors are at full line potential. Also, at full load resistors R, Rx, and RL as well as the nonlinear load will heat to near rating, and forced air cooling may be necessary. The measurements should be done with reasonable speed and the equipment should be allowed to cool between readings. Table 20 shows a suitable data sheet for this test.
2. The synchronizing pulse output of the test set shown in Figure 27 may be used as an input to an oscilloscope to better identify the transfer point. If the UPS under test has a clear indication of load status (i.e., supported by line, supported by UPS), the 12-VDC circuit at the bottom of Figure 27 need not be used. If this circuit is not used, be sure that the "push to test" switch in parallel with Rx can break full load current of the UPS plus 50 percent.
3. At this point, distortion is introduced by setting the triac load to an intermediate value. A suitable setting of the triac load is about half the power rating of the UPS. This will result in voltage distortion as measured by the signal analyzer. Set Rx to zero and readjust the variac so that the UPS voltage is at rating. Record the THD in this configuration and again experimentally find the trip point of the UPS. As before, if the UPS does not transfer load to the UPS source,

increase Rx; if the UPS does transfer load, try to decrease Rx. Observe the shock and heating hazards. Record the value of V2 such that the load is transferred to the UPS.

4. Repeat the procedure with the triac load set at about 75 percent, 90 percent, and full load. Experimentally find the trip voltages in each case. It is expected that if there is a significant degradation in trip voltage, the characteristic illustrated in Figure 28 will result. If there is no degradation in trip voltage, the experimentally determined values of V2, even for high-supply voltage THD, will be virtually constant.

### **Test of the UPS as a Power Conditioner and Isolation of the Load and Supply Busses (Test of Impulses Inserted in Load Circuit)**

In this test the electrical isolation of the UPS is tested by inserting impulses into the load circuit and measuring the resulting impulses that are passed through to the supply side. Figure 29 illustrates the essence of the test. The isolation is determined by measuring the ratio of the impulses shown in the figure and calculating the common logarithm of the ratio,

$$A = 10 \log_{10} \frac{V_{\text{impulse line side}}}{V_{\text{impulse load side}}} \quad [\text{Eq 9}]$$

In this expression, A is the isolation of the UPS in decibels (dB).

The test is done using the test set shown in Figure 30. In this test set, the line voltage is rectified and used to charge capacitors, which in turn are discharged into the load circuit. The load circuit is at rated load for this test at unity power factor. The energy (in joules) that is discharged into the load circuit may be established by setting switches S1, S2, and S3. Table 21 shows the component ratings and values for this test set.

The test is performed as follows:

1. Load the UPS to rated value at unity power factor. This may be done using a laboratory resistor, the test set shown in Figure 12, or household space heaters of an appropriate size and setting to produce the rated load.
2. Using the impulse test set shown in Figure 30, set switches S1, S2, and S3 as indicated in Table 22 to obtain a 5-J impulse level. Apply the impulse to the load circuit using the "push to test" switch and record the load- and line-side impulse levels. Figure 31 shows the correct way to record the impulse level.

3. Repeat the impulse test with the same 5-J setting several times (about 10 is suggested). This will result in a positioning of the impulse at several points randomly along the sine wave load voltage. Record the line-side and load-side impulse voltage each time. The line- and load-side characteristics may exhibit ringing (see Figure 32); if this occurs, record the frequency of the ringing. A suitable data sheet is shown in Table 23.
4. Between runs the impulse test set must recharge. The approximate recharge time for this set is 1 minute at the highest energy setting (35 J) and about 10 seconds at the lowest energy setting (5 J). Allow the proper recharge time to obtain the maximum energy from the set.
5. Calculate the UPS isolation,  $A$ , in decibels.
6. Repeat the test at 10, 15, 20, 25, 30, and 35 J.

Table 24 is suggested as a criterion for assessing UPS isolation.

### **Test of the UPS as a Power Conditioner and Isolation of the Load and Supply Busses (Test of Impulses Inserted in Supply Circuit)**

In this test the isolation of a UPS is again measured, but this time the impulse is applied to the line side. The UPS load voltage is instrumented to measure the isolation. The test is similar to the test of the UPS as a power conditioner with impulses inserted on the load side. Figure 33 illustrates the test configuration. In this test set, capacitive impulse storage is again used and the test set is shown in Figure 34; therefore, the same component ratings and energy storage tables used in the load-side test apply (Tables 21 and 22). An inductor choke (L1) is used at the line side of the input impulse test set to help isolate the test set from the AC supply. The function of the input capacitor (C3) is similar. The ratings of these additional elements are shown in Table 25.

The test is performed as follows:

1. Load the UPS to rated value at unity power factor. This may be done using a laboratory resistor or any other convenient load that is not likely to vary in resistance, the test set shown in Figure 12, or household space heaters of an appropriate size and setting to produce the rated load.
2. Using the impulse test set shown in Figure 34, set switches S1, S2, and S3 as indicated in Table 22 to obtain a 5-J impulse level. Apply the impulse to the line side of the circuit using the "push to test" switch and record the load- and line-side impulse level. As before, Figure 31 shows the correct way to record the impulse level.

3. Repeat the impulse test with the same 5-J setting several times (about 10 is suggested). This will result in a positioning of the impulse at several points randomly along the sine wave line voltage. Record the line-side and load-side impulse voltage each time. The line- and load-side characteristics may exhibit ringing (see Figure 32); if this occurs, record the frequency of the ringing. A suitable data sheet is shown in Table 26.
4. Between runs the impulse test set must recharge. The approximate recharge time for this set is 1 minute at the highest energy setting (35 J) and about 10 seconds at the lowest energy setting (5 J). Allow the proper recharge time to obtain the maximum energy from the set.
5. Calculate the UPS isolation,  $A$ , in decibels.
6. Repeat the test at 10, 15, 20, 25, 30 and 35 J.

Table 24 is suggested as a criterion for assessing UPS isolation.

**Table 5. Power quality problems for which UPS operation may be susceptible to degraded performance.**

Power Quality Problem	Degraded Wave Shape in Which Circuit		Characteristics
	Input (line)	Output (load)	
Load current harmonics		X	Certain types of loads require harmonic currents for proper operation (e.g., rectifier loads). Possible undesirable UPS operation includes improper transfer of load and excess loss.
Load current spikes and commutation notches		X	Certain types of loads such as ASD loads have momentary low-voltage conditions and highly inductive load current switching. This may degrade UPS response.
Isolation of line and load	X	X	UPS should act as a line conditioner to block and to isolate the line from power quality problems in the load.
Line bus voltage spikes	X		Line voltage spikes may not be sufficiently isolated from the load.
Momentary outages in the line	X		Repeated line-side outages may degrade UPS response.
Line voltage harmonics	X		Supply voltage harmonics may cause excess heating and other degraded performance of the UPS.

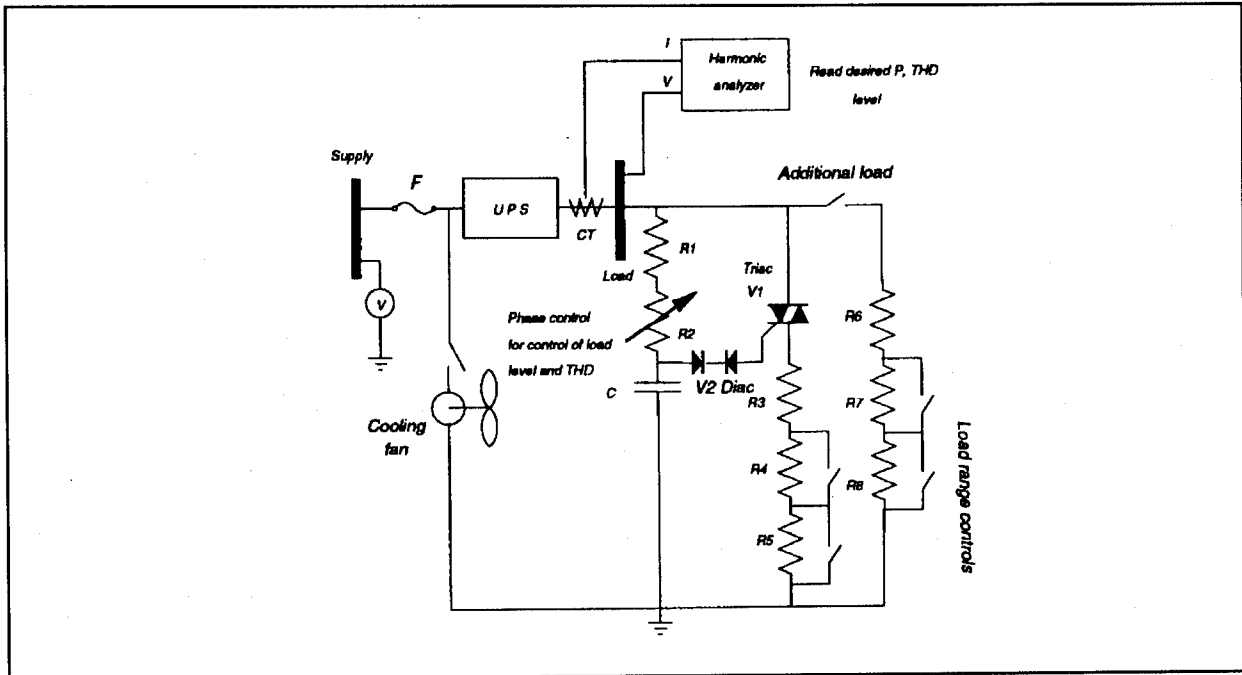

Figure 12. Triac-switched resistive load for testing a UPS.

Table 6. Circuit component values for a triac load test set.

Supply Voltage	UPS full load	R1 and power rating	R2 (max) and power rating	R3 through R8, each	Power rating for R3 through R8	C and volt rating	V1 V and power rating	V2 V rating	F
Volts	VA	$\Omega/W$	k $\Omega/W$	Ohms	Watts	$\mu F/kV$	kV/kW	kV	A
120	250	1700/2	400/2	40	50	0.1/1	0.6/1	0.6	5
	500	1700/2	400/2	20	100	0.1/1	0.6/1	0.6	7.5
	750	1700/2	400/2	12	150	0.1/1	0.6/2	0.6	10
	1000*	1700/2	400/2	10	200	0.1/1	0.6/2	0.6	15
220	1500*	350/2	750/2	20	250	0.05/2	2./3.	2.0	10
	2000*	3500/2	750/2	16	500	0.05/2	2./5.	2.0	15

\*Forced air cooling of R3-R8 of at least 500 cfm is recommended at and above 1000 W loading



Table 8. Component ratings and values for the low voltage test set depicted in Figure 13.

Supply Voltage	UPS Full Load	X1		X2		F
V	VA	V	VA	V	VA	A
120	250	120/240	500	0-150	500	5
	500	120/240	1000	0-150	1000	7.5
	750	120/240	1000	0-150	1000	10
	1000	120/240	2000	0-150	2000	15
220	1500	120/240	3000	0-150	3000	10
	2000	120/240	3000	0-150	3000	15

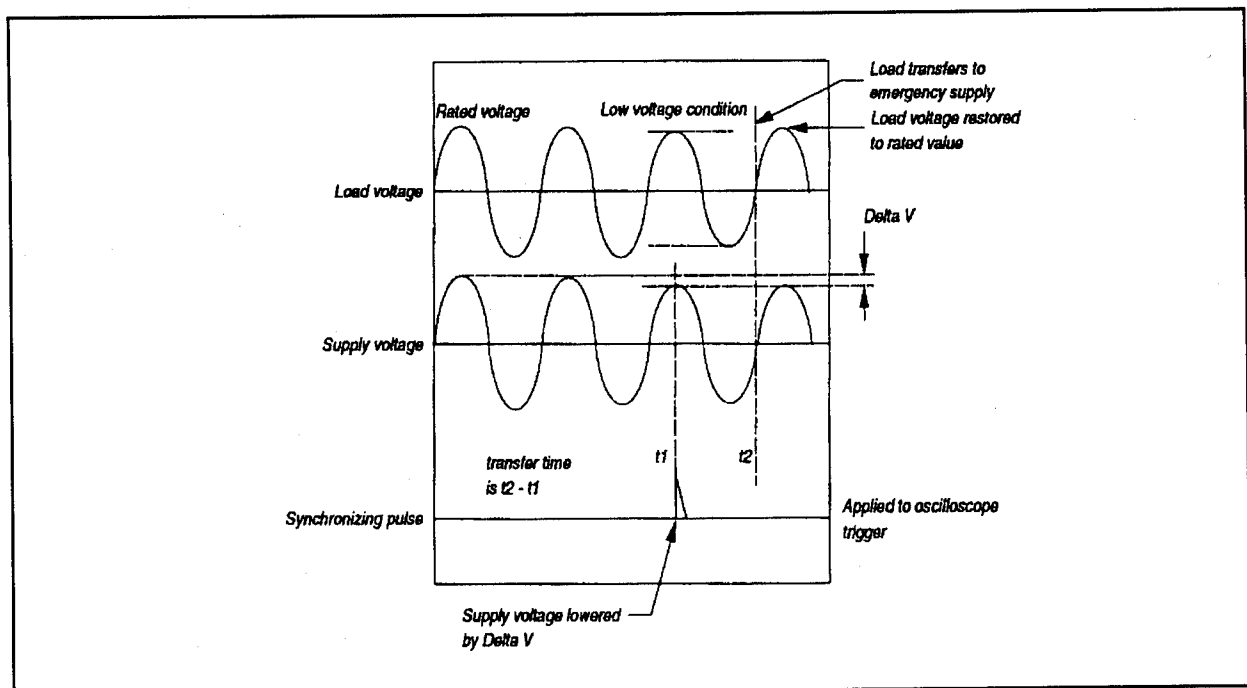

Figure 14. Recognizing the transfer time of a UPS upon application of a low-voltage condition.

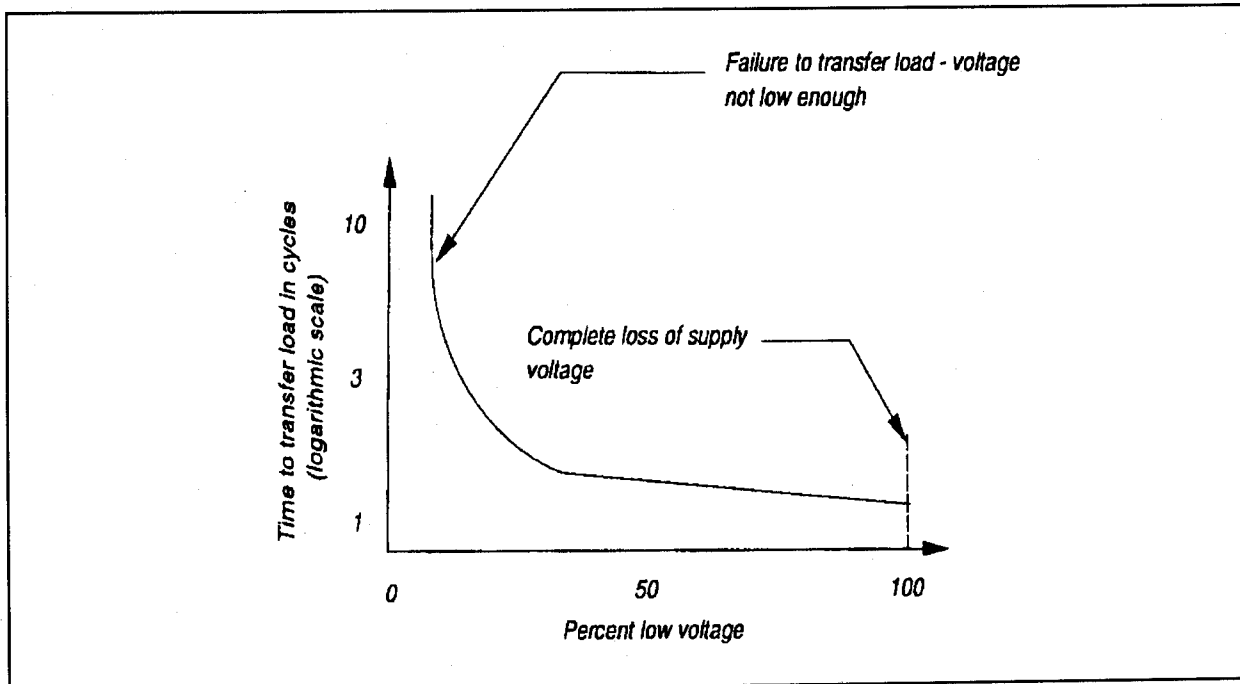

Figure 15. Typical times of transfer characteristic of a UPS.

Table 9. A qualitative evaluation of UPS load transfer time versus load current THD.

Percent increase in load transfer time at full active power load and unity power factor (transfer time at zero THD vs. transfer time at load current THD)	For a given load current THD in this range	Susceptibility
0 - 10%	0 - 50%	Low
10 - 50%	0 - 50%	Medium
50 - 100%	0 - 50%	High
Over 100%	0 - 50%	Unacceptable

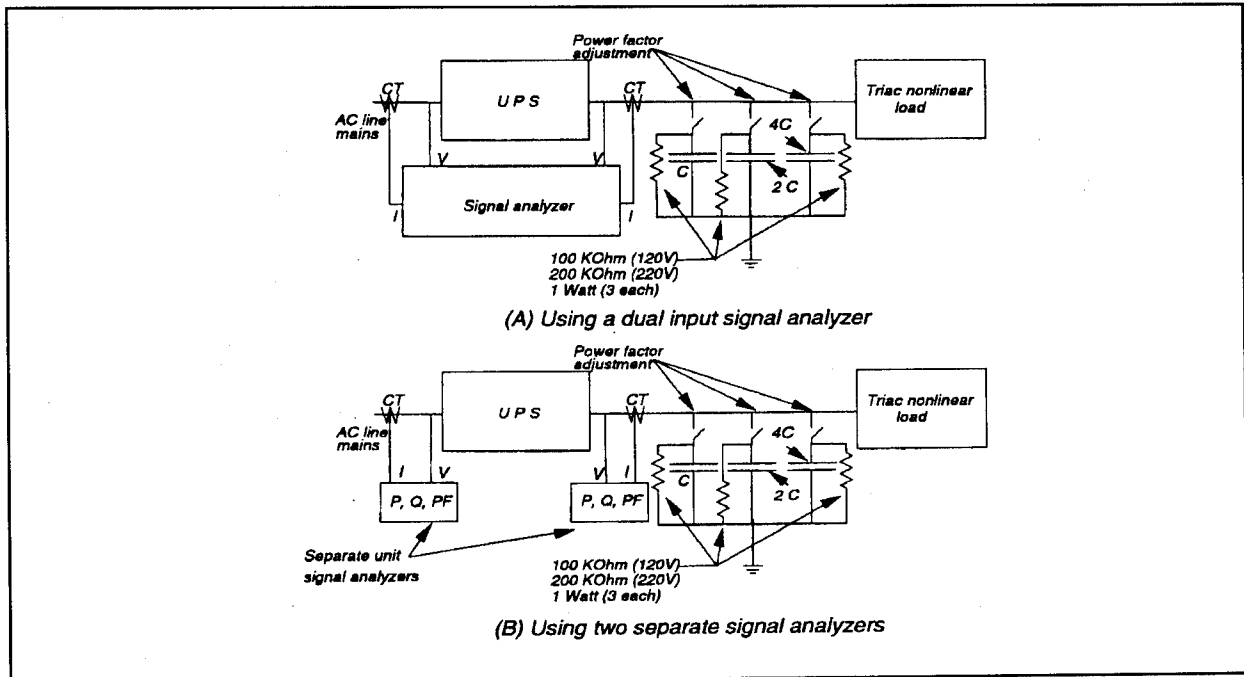

Figure 16. Basic test configuration for measuring the efficiency of a UPS.

Table 10. Capacitor ratings and values for the efficiency test set depicted in Figure 16.

Supply Voltage	UPS Full Load	Capacitance	C
V	VA	$\mu F$	rated voltage (V)
120	250	7.5	1000
	500	15	1000
	750	22.5	1000
	1000	30	1000
220	1500	10	3000
	2000	15	3000



Table 12. Qualitative assessment of the efficiency of a static UPS operating under distorted or undistorted load current.

Rating kVA	Efficiency in %		
	Low loss	Typical	High loss
<1.0	>85	70 - 85	<70
1 - 10	>90	80 - 90	<80
> 10	>92	85 - 92	< 85

Table 13. Assessment of the temperature rise of UPSs under nonlinear load.

Temperature rise	Location	
	Exterior	Interior
More than 10 °C below UL 1778 requirements	Satisfactory	Satisfactory
0-10 °C below UL 1778 requirements	Marginal	Satisfactory
Violates UL 1778 requirements	Unacceptable	Check for component damage and possible loss of life and fire hazard

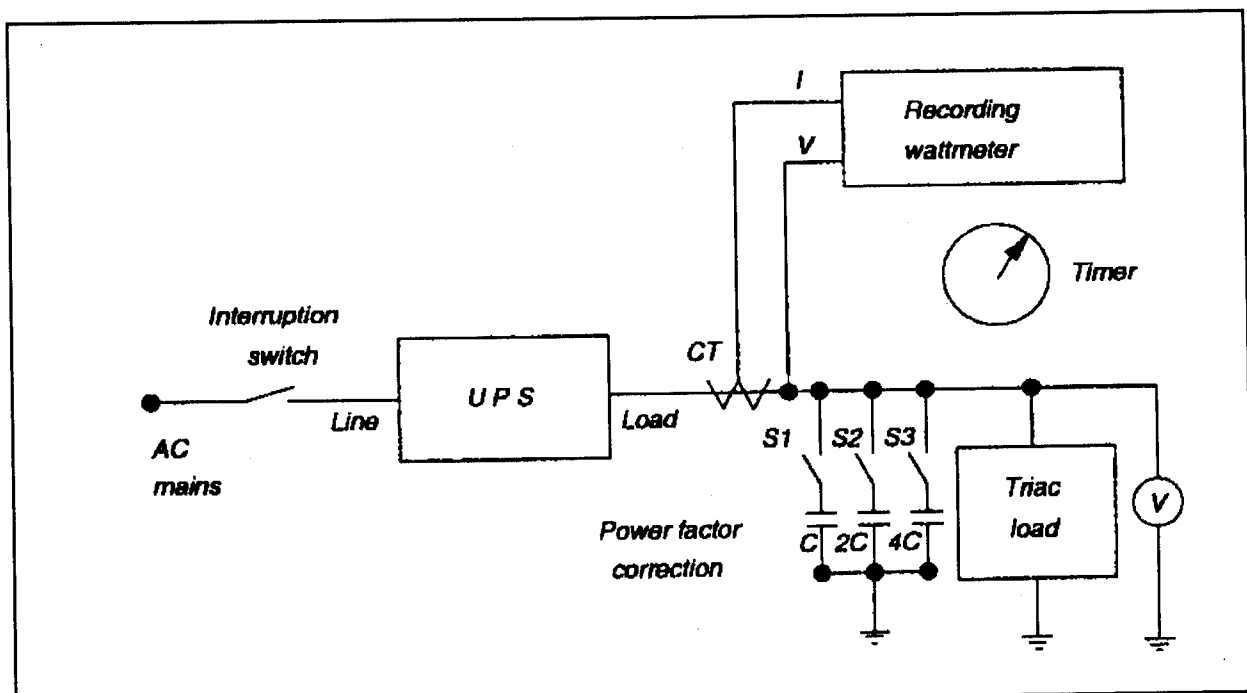

Figure 18. Measurement of the longevity of supporting a full load of a UPS for different harmonic load currents.



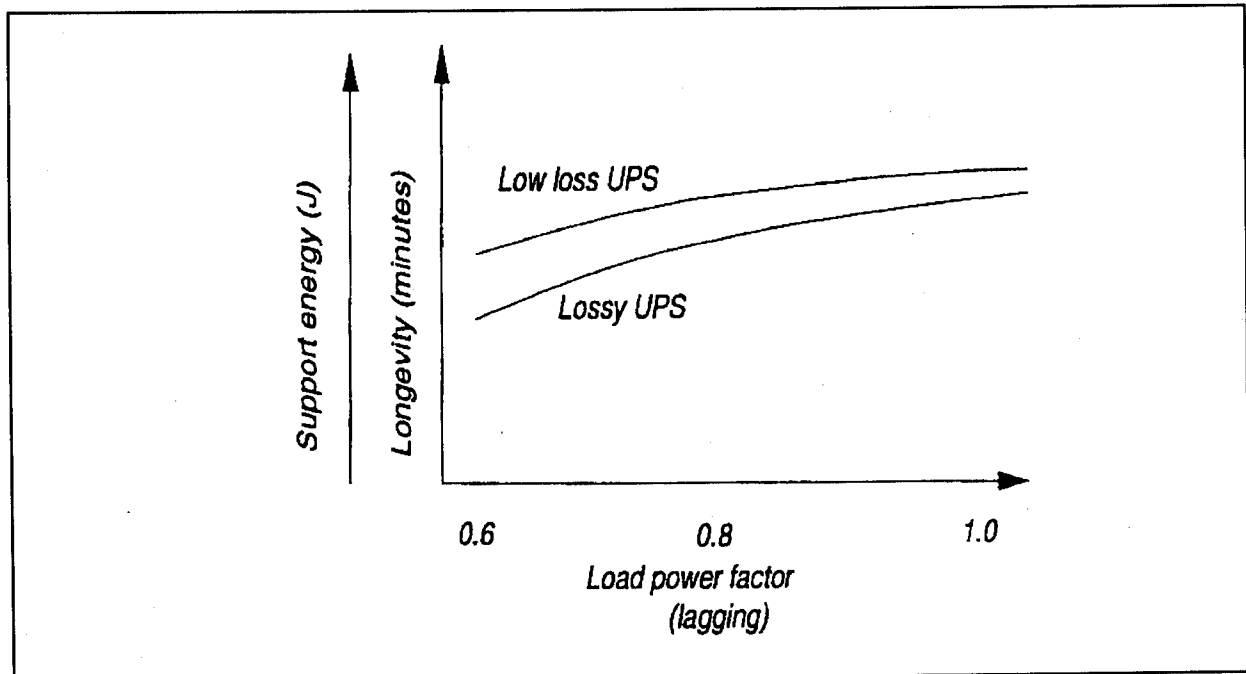

Figure 20. Expected trend of longevity of load support versus load current power factor.

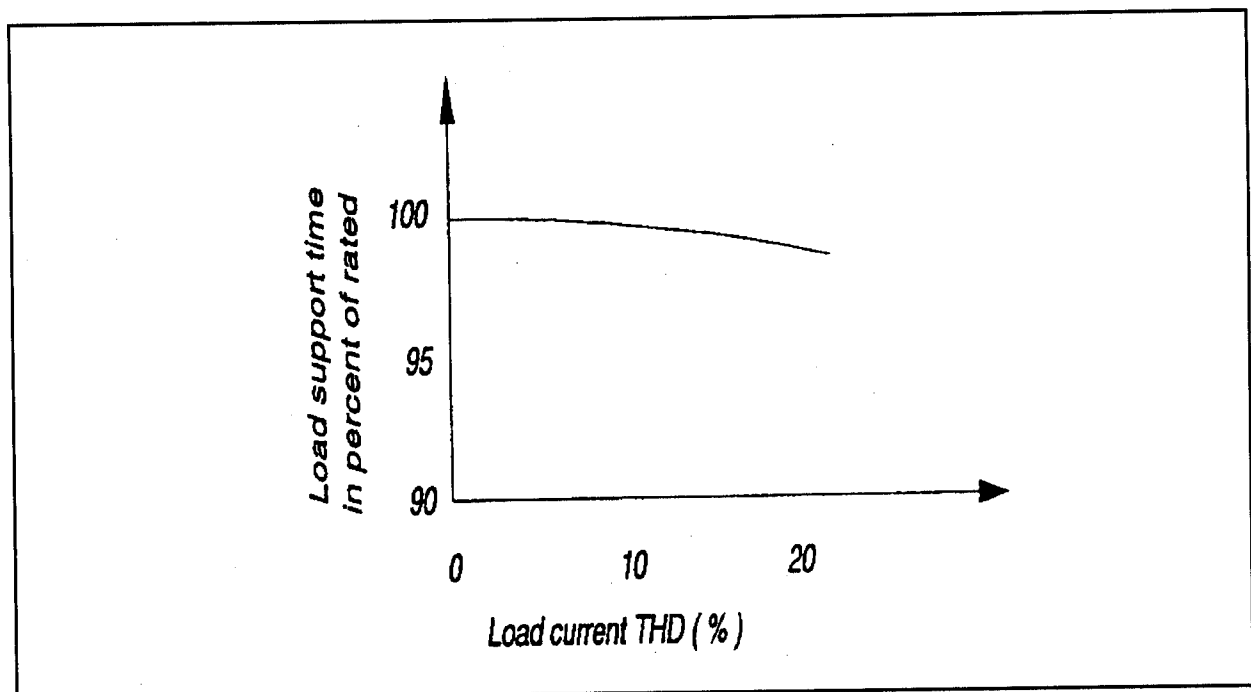

Figure 21. Load support time sensitivity to load current THD.

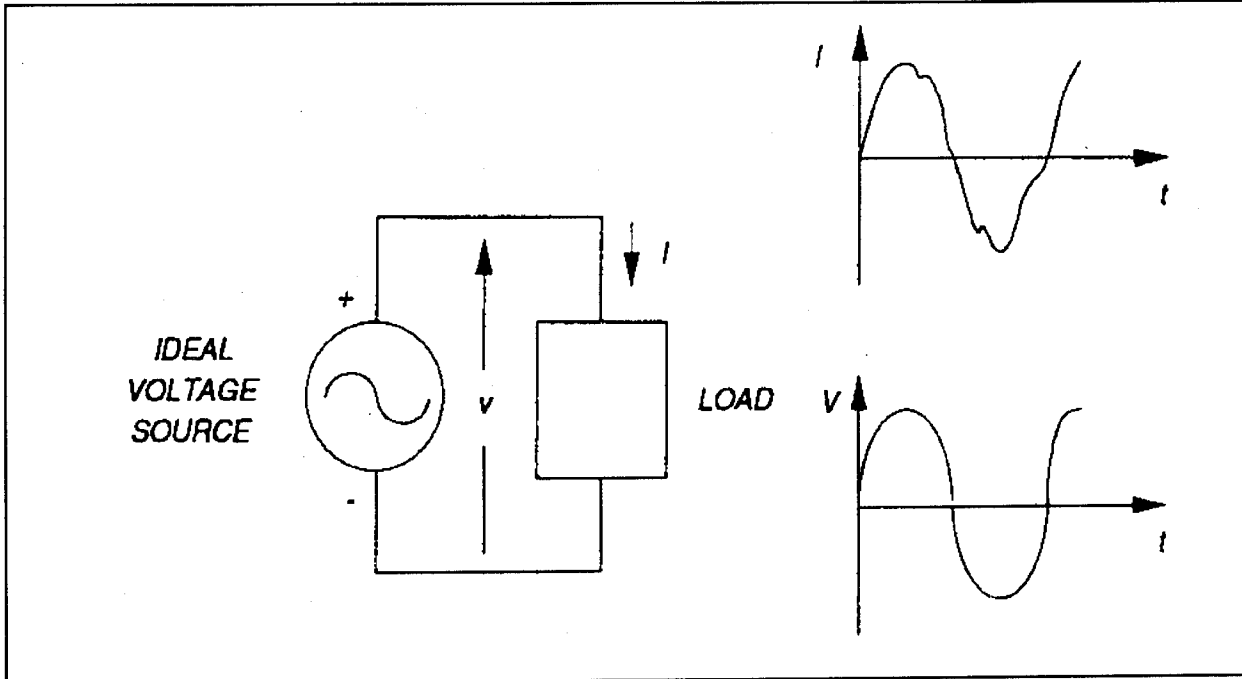

Figure 22. Depiction of an ideal voltage source.

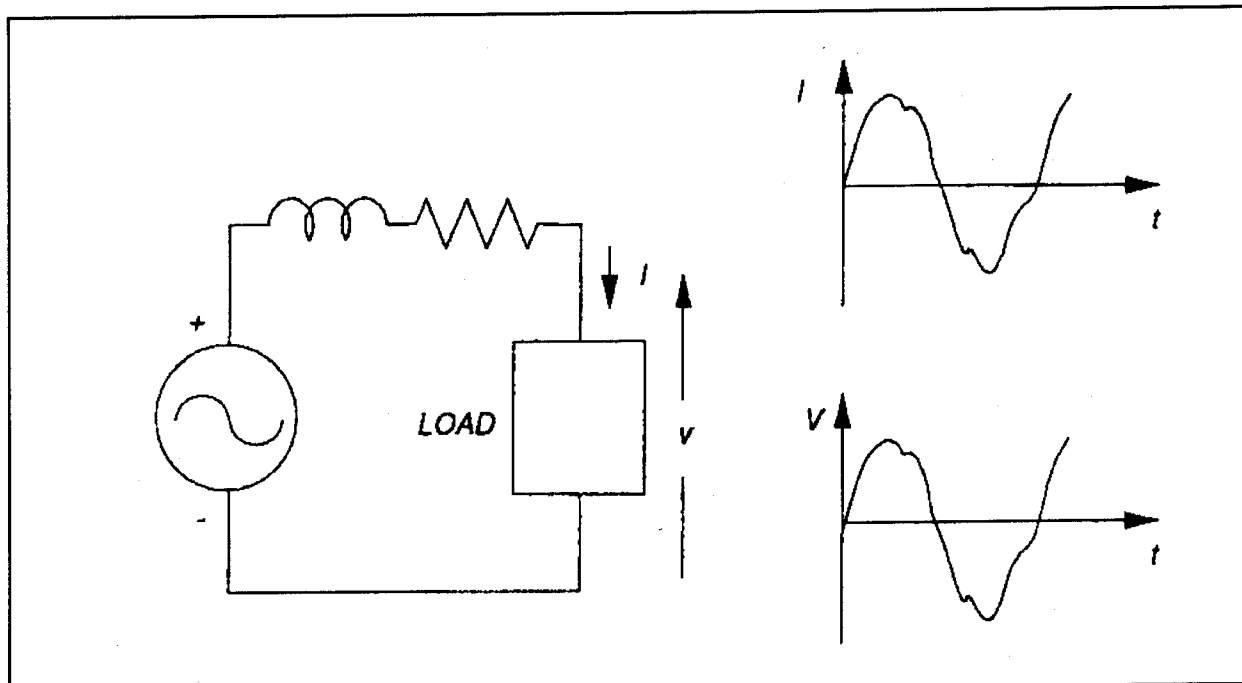

Figure 23. Depiction of a nonideal voltage source and bus voltage distortion.



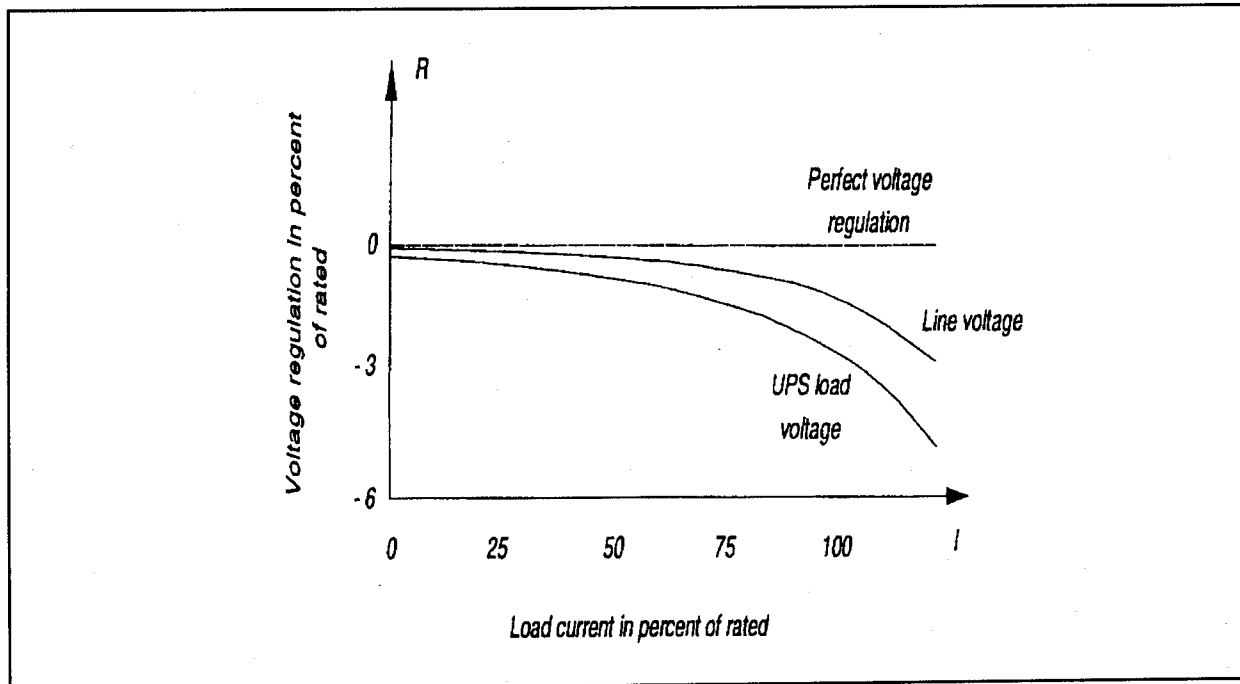

Figure 25. Typical bus voltage regulation characteristics at the AC mains and at the load side of an unregulated UPS.

Table 16. Load bus voltage regulation when UPSs are used for nonlinear loads.

Load bus voltage regulation at full load and at least 20% load current THD	Assessment of UPS regulation
Less than $\pm 1\%$	Excellent
Less than $\pm 3\%$	Good
Less than $\pm 6\%$	Fair
Greater than $\pm 6\%$	Potentially unacceptable

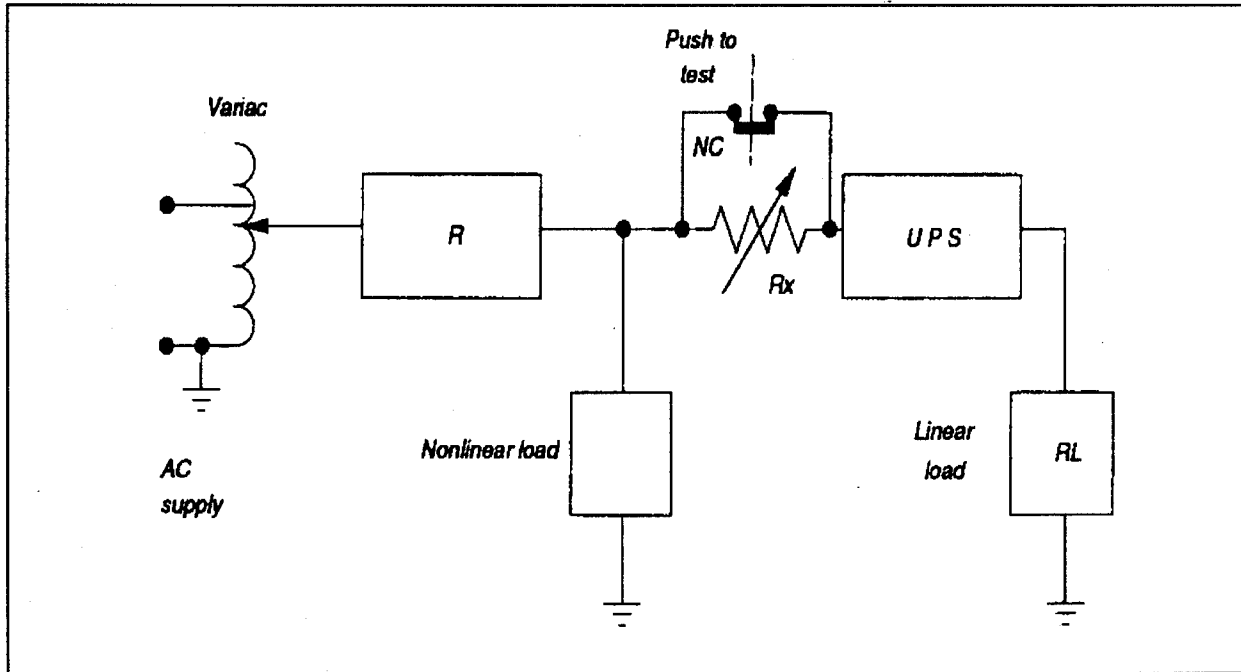

Figure 26. Illustration of a test set to measure the susceptibility of a UPS to transfer load when the supply voltage is contaminated by harmonic components.

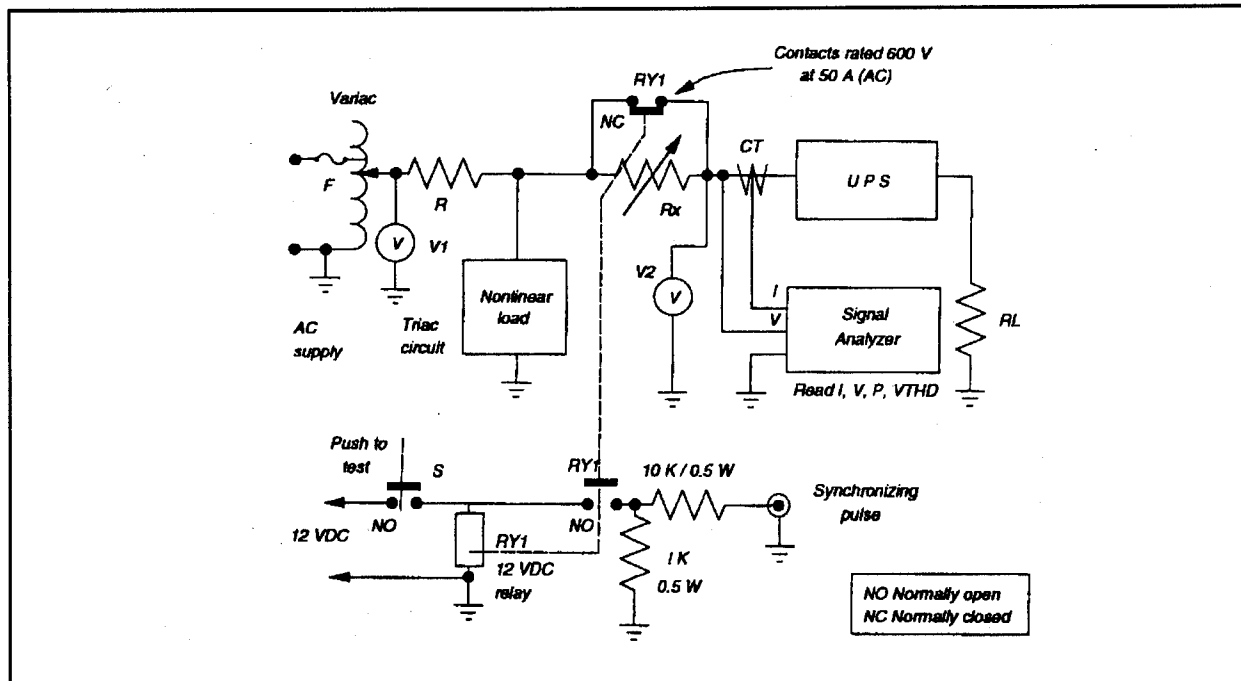

Figure 27. Test set for the measurement of the susceptibility of a UPS to transfer load when the supply voltage is contaminated by harmonics.

Table 17. Ratings and component values for the test set shown in Figure 27.

Voltage rating	Power rating	F	R		Rx slidewire rheostat		RL	
			Ohms	Watts	Ohms	Watts	Ohms	Watts
120	250	5	2.5	50	0 - 20	100	57.6	250
	500	10	1.2	100	0 - 10	150	28.8	500
	750	15	0.8	150	0 - 10	250	19.2	750
	1000	20	0.6	200	0 - 5	300	14.4	1000
220	1500	15	1.5	300	0 - 20	500	32.3	1500
	2000	25	1.0	500	0 - 10	750	24.4	2000

Forced-air cooled

Table 18. Ratings for the variac used for the test set shown in Figure 27.

Voltage Rating	Power Rating	Variac Rating	
		V	VA
120	250	120/135	500
	500	120/135	1000
	750	120/135	1500
	1000	120/135	2000
220	1500	220/250	3000
	2000	220/250	4000

Table 19. Voltage ratings for resistors used in the test set of Figure 27—for shock hazard prevention.

Voltage Rating	Power Rating	R	Rx	RL
		Voltage Rating in V	Voltage Rating in V	Voltage Rating in V
120	250	600	600	220
	500	600	600	220
	750	600	600	220
	1000	600	600	220
220	1500	1000	1000	440
	2000	1000	1000	440



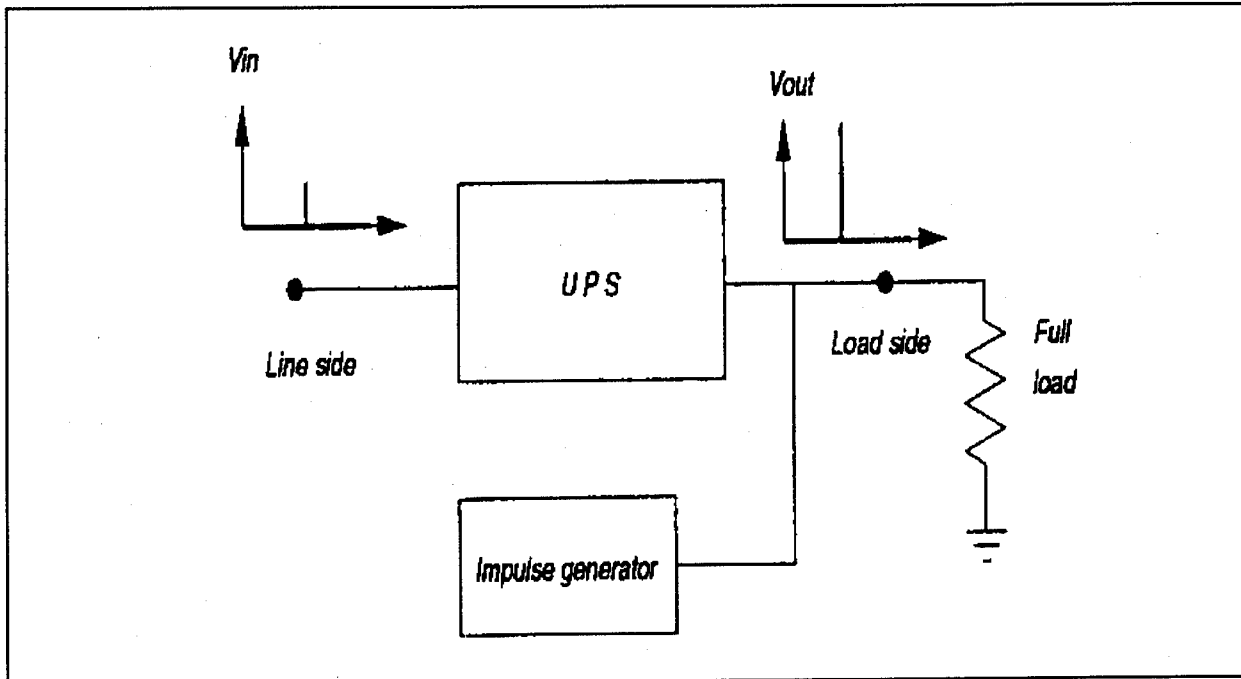

Figure 29. Representation of the test of electrical isolation of a UPS by inserting impulses into the load circuit.

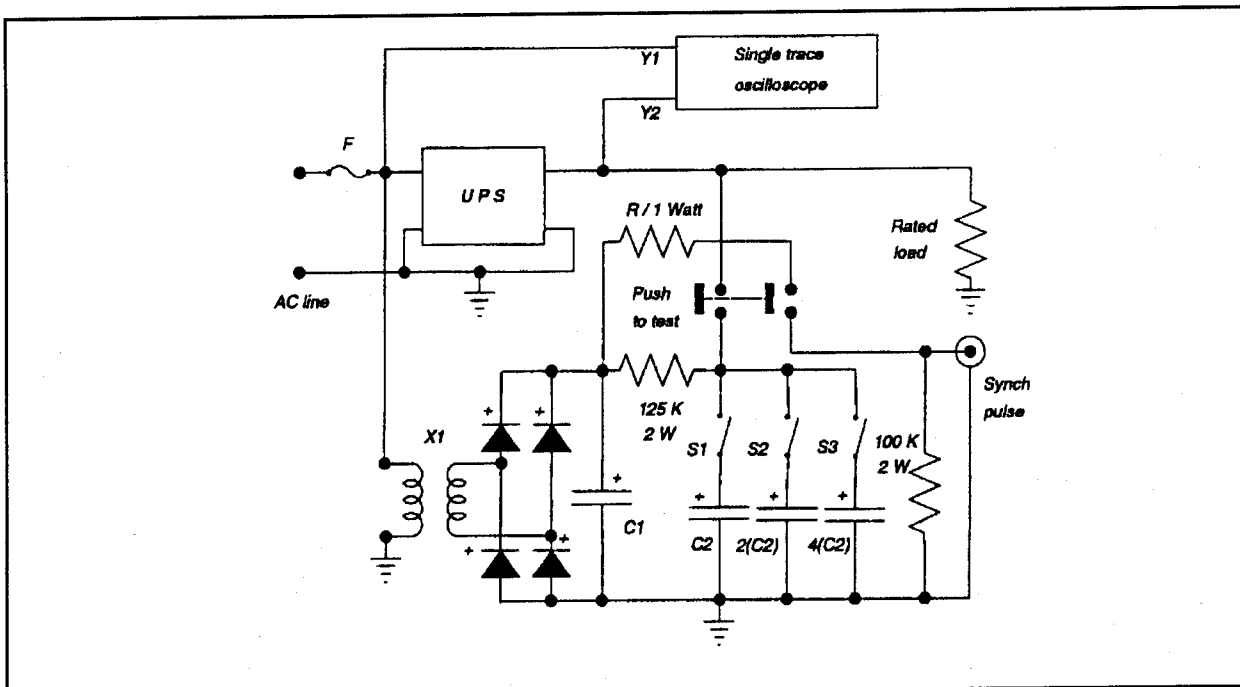

Figure 30. Representation of the test of electrical isolation of a UPS by inserting impulses into the load circuit.

Table 21. Component ratings and values for load- and line-side impulse test.

Supply Voltage	UPS Rating	X1	C1	C2	R	F
Volts	VA	Voltage rating/ VA rating	$\mu$ F/ Voltage rating	$\mu$ F/ Voltage rating	Megohms	A
120	250	120/175 at 2kVA	10 at 1 kV	40 at 1 kV	1	5
	500	120/175 at 2kVA	10 at 1 kV	40 at 1 kV	1	7.5
	750	120/175 at 2kVA	10 at 1 kV	40 at 1 kV	1	10
	1000	120/175 at 2kVA	10 at 1 kV	40 at 1 kV	1	15
240	1500	120/175 at 4kVA	2.5 at 2 kV	10 at 2 kV	2	10
	2000	120/175 at 4kVA	2.5 at 2 kV	10 at 2 kV	2	15

Table 22. Switch settings in load- and line-side impulse test.

Impulse energy (Joules)	S1	S2	S3
5	X		
10		X	
15	X	X	
20			X
25	X		X
30		X	X
35	X	X	X

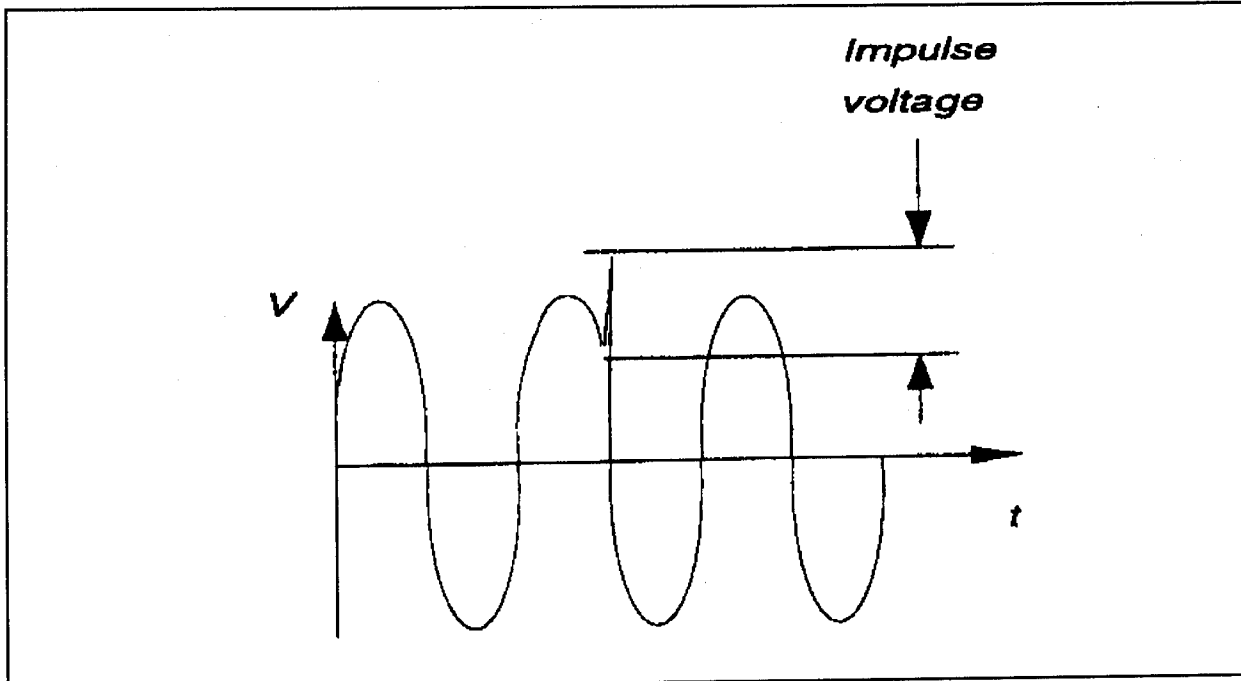

Figure 31. Correct measurement of impulse amplitude for the impulse isolation test.

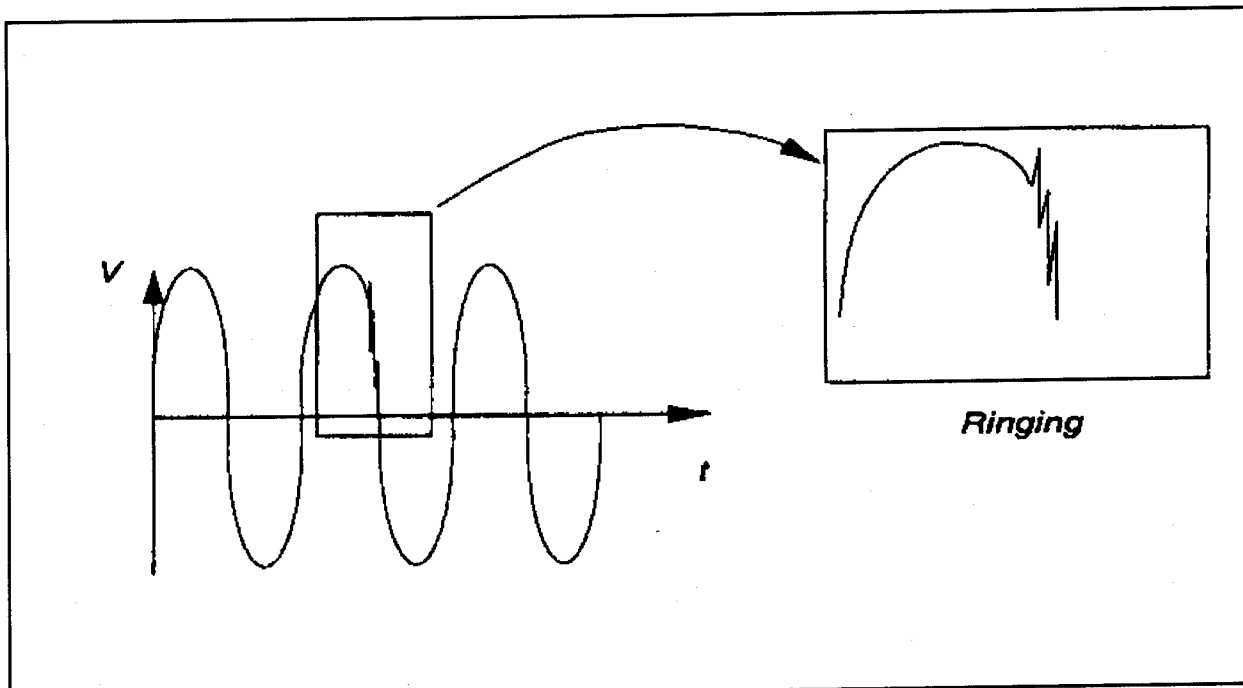

Figure 32. Illustration of ringing in the load bus voltage (or the supply bus voltage).





Table 26. Ratings and values of L1 and C3 for the input impulse test.

Voltage	Power	L1		C3	
Volts	VA	mH	A	$\mu$ F	kV
120	250	5.0	5	5.0	1
	500	2.5	10	5.0	1
	750	1.5	10	5.0	1
	1000	1.5	10	5.0	1
240	1500	3.5	10*	2.5	2
	2000	2.5	10*	2.5	2

\*Choke insulated to 2500 V

## 6 Main UPS Manufacturers

### American Manufacturers

Table 27 lists the main UPS manufacturers in the United States. There are also about 100 U.S. firms that specialize in UPS systems; they use the manufacturers listed in Table 27 and make field modifications as necessary for specific system applications. Most of these firms specialize in computer mainframe applications.

### Foreign Manufacturers

Table 28 contains representative UPSs of foreign manufacture. Not listed are a number of Japanese UPSs not usually exported out of Japan.

### UPSs Recommended for Testing

In this section, several UPSs are recommended for testing with nonlinear loads. The criteria used for making this recommendation include:

- Only UPSs of U.S. manufacture
- Units of 1 kVA or less
- Units of smaller physical size are preferred for testing purposes
- UPS availability
- The availability of UPS descriptions, specifications, ratings, size, and other information
- Units of reasonable cost.

Table 29 lists the units recommended for testing, and Tables 30 and 31 tabulate the main specifications taken from the manufacturers' literature. The list prices of these units are shown in Table 32. The addresses and telephone numbers of the manufacturers appear in Table 27.

Table 27. UPSs of U.S. manufacture.

Manufacturer	Address and Phone Number	Comments
Abacus Controls	95 Readington Road Somerville, NJ 08876 Tel 908-526-6010 Fax 908-526-6866	300 - 10000 VA single phase UPSs
American Power Corporation	132 Fairgrounds Road Kensington, RI 02892 Tel 800-800-4272	"Back-UPS" series 250 - 1250 VA; "Smart-UPS" series 400 - 2000 VA (Also available rack mounted). Extended run UPSs.
Atlas Energy Systems	713 W. Duarte Road Arcadia, CA 91007 Tel 818-575-0755 Fax 818-575-0665	Computer applications, 5.0 to 500 kVA
Baylor Technologies	Box 36326 Houston, TX 77236-6326 Tel 800-531-6065 Tel 713-240-6111 Fax 713-240-5074	Rotary UPSs
Best Power Technology	Route 1, Box 106 Necedah, WI 54646 Tel 800-356-5794 Tel 608-565-7200	Ferups UPSs, 2000:1 isolation from the line, RS232 port, 0.5 - 18 kVA. Fortress series UPS "no break power", 360-2000 VA. Patriot series for high surge protection and EMI/RFI filtering, 300-850 VA. Also marketed as Microferups. Fortress series "level 4" UPSs available in 1 kVA class.
Computer Power	124 West Main Street High Bridge, NJ 08829 Tel 800-526-5088 Fax 908-638-4931	100 VA single phase to 100 kVA three phase ferroresonant technology UPSs
Controlled Power Company	1955 Stephenson Highway Troy, MI 48083 Tel 800-521-4792 Tel 313-528-3700 Fax 313-528-0411	Computer applications, Series 1000
Custom Power, Inc.	5402 Bell Houston, TX 77023 Tel 713-923-7972	Series V UPS
Cyberex	7173 Industrial Park Oval Mentor, OH 44060 Tel 800-292-3739 Tel 216-946-1783 Fax 216-946-5963	Computer and petrochemical applications, UPSs to 1.0 MVA, "QP+" series

Manufacturer	Address and Phone Number	Comments
Deltec	2727 Kurtz Street San Diego, CA 92110 Tel 800-854-2658 Tel 619-291-4211 Fax 619-299-6124	Watchman series, 525-1050 VA single phase; "2000 series" 2-5 kVA, rack mounted; "7000 series" 8-10 kVA single phase; "8000 series" 10-25 kVA three phase units; "9000 series" 37.5-56.25 kVA three phase units
EFI	2415 South 2300 West Salt Lake City, UT 84119 Tel 800-877-1174	"SysGradé" unit rated 505 VA; "LanGardé" units available 400 - 1250 VA
Emerson Computer Power	Liebert Corporation 9650 Jeronimo Road Irvine, CA 92718 Tel 800-368-5590 Tel 800-283-7286 Tel 714-457-3600 Fax 714-457-3787	Computer UPSs, 150 to 2100 VA single phase unit, 3 to 18 kVA three phase units, Liebert manufactures UPSs to 3 MVA
International Power Machines	2975 Miller Park North Garland, TX 75042 Tel 800-527-1208 Tel 214-272-8000 Fax 214-494-2690	"Balanced power plus" series 10 - 300 kVA, three phase, series 1000 UPSs 3 - 15 kVA, "Endless power" series 32 - 167 kVA
Isoreg	Isoreg Corporation 410 Great Road P.O.Box 486 Littleton, MA Tel 508-486-9483	Isoguard UPSs 1000 VA class uses PWM technology, improved over previous models and lighter weight
Liebert	(see Emerson Computer Power)	
Lortec	145 Keep Court Elyria, OH 44035 Tel 800-927-5051 Tel 216-327-5050 Fax 216-327-9628	3-225 kVA UPSs, two main series denoted as the "transistorized" and "thyristor" series
Magnetek	901 East Ball Road Anaheim, CA 92805 Tel 714-956-9200 Fax 714-956-5397	Single phase UPSs 2.1-25 kVA, nonlinear load UPS 20-62 kVA, high power units to 4 MVA, 400 Hz units
Nova Electric	Nova Electric Corporation 100 School Street Bergenfield, NJ 07421 Tel 201-385-0500 Tax 201-385-0702	Rack-mounted UPSs 1 to 5 kVA. Galaxy cabinet model UPSs 3 to 5 kVA. Also inverters. Partial product catalog in Appendix A.

Manufacturer	Address and Phone Number	Comments
On-Line Power	5701 Smithway Street Commerce, CA 90040 Tel 800-227-8899 Tel 213-721-5017 Fax 213-721-3529	A variety of series of UPSs. The "K-Factor" series is available in 15 to 500 kVA, which can be loaded to 100% nonlinear load. The standard temperature rise of 150 °C is available as well as a special order 80 °C. Single phase units of 1.0 kVA to three phase units to 75 kVA also available.
Oneac	27944 N. Bradley Road Libertyville, IL 60048 Tel 800-327-8801	Computer applications, 400 - 1800 VA, 120 and 230 UPSs; videotape available on their products. Partial product catalog in Appendix B.
Pacific Power Source	15122 Bolsa Chica Street Huntington Beach, CA 92649 Tel 800-854-2433 Tel 714-898-2691 Fax 714-891-1928	Fast switching UPSs, computer applications, 15, 20, and 30 kVA three phase units. Partial product catalog in Appendix C.
Power Systems and Controls	3206 Lanvale Avenue Richmond, VA 23230 Tel 804-355-2803	Series XC 250 to 1250 kVA
Powervar	28457 N. Ballard Drive Lake Forest, IL Tel 800-369-7179	Computer and industrial applications
Precise Power Corporation	715 60th Court East P.O.Box 9547 Bradenton, FL 34206-9547 Tel 813-746-3515 Fax 813-745-1054	15 second ride through of full load, motor/generator sets, all nonelectronic
RSI	(See United Power Technology)	
S. L. Waber	520 Fellowship Road Mt. Laurel, NJ 08054 Tel 800-788-8427	Original equipment manufacturer, medical and computer applications. Small UPS in 250 and 500 VA sizes; Linegard series in 300 and 600 VA sizes; and Linebacker series in 300, 500, and 1250 VA sizes. Partial product catalog in Appendix D.
Sola Basic (GS-Sola)	General Signal - Sola 1717 Busse Road Elk Grove Village, IL Tel 800-879-7652 Tel 800-2443-8160 Tel 312-439-2800 Tel 708-439-2800 Fax 800-626-6269	1 kVA class UPSs available with and without power conditioning. The units without conditioning have surge suppression.

Manufacturer	Address and Phone Number	Comments
Superior Electric	Superior Electric Co. 383 Middle Street Bristol, CT 06010-7488 Tel 203-582-9561 Fax 203-589-2136	Warner Electric Co. products. Range of 0.4-1.5 kVA UPSs, rack mounted and cabinet Stabline series, electronic and computer applications. Partial product catalog in Appendix E.
Topaz	Topaz Systems 1660 Scenic Avenue Costa Mesa, CA 92626 Tel 800-344-0570 Tel 714-557-1636 Fax 714-434-7652	Micro II UPS available 600-1300 VA. Powermaker brand UPSs available with and without power conditioning, in range of 1.8 - 2.5 kVA. Powermaker mini-UPS available 3.5-10 kVA. All units are single phase. Division of the Square D company. Partial product catalog in Appendix F.
Tripp-Lite	500 N. Orleans Avenue Chicago, IL 60610-4188 Tel 312-329-1777 Fax 312-644-6503 Distributed by ITC Electronics 2772 West Olympia Blvd. Los Angeles, CA 90006 Tel 800-394-5416 Fax 800-934-1137	BC series available 250-4000 VA; the Omnipower series includes a voltage regulator and is available 459- 2000 VA. The Unison series "reconstructs" the sine wave - available 450-1500 VA. Computer applications for most models including interface connections for Local Area Network (LAN) servers. Partial product catalog in Appendix G.
United Power Technology (also known as RSI)	United Power Technology 19480 T. E. Colina Drive Walnut, CA 91789-4324 Tel 800-755-9959 (Texas) Tel 800-659-2412 (California) Fax 818-912-0796 and Reliable Source (RSI) 610 Presidential, Suite 100 Richardson, TX 75081 Tel 800-755-9959 Fax 214-907-2778	Computer power supplies. UPSs 350- 700 VA with build in battery, 1-10 kVA units with outboard battery, PWM logic and VLSI controls

Table 28. UPSs of foreign manufacture.

Manufacturer	Country of origin	UPS types
Ganz	Hungary	General purpose
Phillips	Netherlands	Rack-mounted, cabinet types, intended primarily for computer and communications industry
Toshiba	Japan	Mainly UPSs for mainframe and small computers
Zzap Power	Canada	Markets a number of US and Canadian UPSs and other power quality equipment. Zzap has offices in New York and Quebec.

Table 29. UPSs recommended for testing.

Identifying letter	Manufacturer	VA rating	Model	Model number
A	Best	1000	Fortress	950
B	Isoreg	1000	Isoguard	PWM-16-100-12-12-12-4-UU
C	Oneac	1300	ON series	ON1300A-SO
D	Sola	1000	-	54-216-19
E	Superior	1250	UPS	UPSY61012R
F	Topaz	1000	Powermaker	81100VR
G	Tripp-Lite	1200	MPS series	MPS1200

Table 30. Main electrical specifications for UPSs recommended for testing.

UPS	A	B	C	D	E	F	G
<b>Parameter</b>							
<b>Power (VA)</b>	950	1000	1300	1000	1250	1000	1200
<b>Line voltage (V)</b>	120	120	120	120	120	120	120
<b>Load voltage (V)</b>	120	120	120	120	120	120	120
<b>Phase</b>	1	1	1	1	1	1	1
<b>Time to support full load (min)</b>	8	N/A	7	N/A	N/A	12	10
<b>Time to support half load (min)</b>	16	N/A	22	N/A	N/A	25	22
<b>Time to recharge (h)</b>	3 (est.)	N/A	4	Ten times discharge time	N/A	12	8
<b>Voltage regulation used</b>	Yes	N/A	N/A	Yes	N/A	Yes	N/A
<b>Line voltage transfer points (line to UPS, V)</b>	110/126	N/A	N/A	N/A	N/A	96/138	N/A
<b>Line voltage transfer points (UPS to line, V)</b>	N/A	N/A	N/A	N/A	N/A	102/132	N/A
<b>Load transfer time (ms)</b>	0	N/A	2	N/A	N/A	4	0
<b>Overload Protection</b>	Yes	N/A	N/A	Yes	Yes	Yes	N/A
N/A = Data not available							

Table 31. Main mechanical specifications for UPSs recommended for testing.

UPS	A	B	C	D	E	F	G
<b>Parameter</b>							
<b>Dimensions (H, inches)</b>	N/A	21.5	12	9.69	N/A	9.6	19
<b>(W, inches)</b>	N/A	22.25	8.3	17.09	N/A	6.5	6
<b>(D, inches)</b>	N/A	22.25	20.3	23	N/A	16.7	17.25
<b>Volume (in<sup>3</sup>)</b>	N/A	10644	2022	3809	N/A	1042	1967
<b>Net weight (lbs)</b>	45	199	100 (107*)	69	70 (79*)	55	N/A
<b>Battery type</b>	SLA	SLA	SLA	SLA	SLA	SLA	SLA
SLA = Sealed lead acid battery * = Shipping weight							

Table 32. List prices for UPSs recommended for testing.

Unit	Manufacturer	List price (\$)	Includes shipping cost?
A	Best	784*	Yes
B	Isoreg	2205**	No
C	Oneac	1299	No
D	Sola	898	No
E	Superior	1192.50***	No
F	Topaz	1095	No
G	Tripp-Lite	1699	No

\* = Includes 21.5% discount for government sales  
\*\* = Government price  
\*\*\* = GSA price schedule

## 7 Summary and Recommendations

Although most electrical characteristics of UPSs are not currently subject to codes and standards, desired evaluation guidelines for test results have been presented. Several commercially available UPSs have been recommended for testing.

The following test methodology was developed for evaluating the susceptibility of UPS systems to nonlinear loads.

### Summary of Tests

**Load transfer tests** measure the time and the supply voltage required for the UPS to sense the loss of mains power and transfer the nonlinear load to the UPS source. Evaluation of test results is made on the degree of degradation of load transfer time with increasing load current THD, using Table 9 as a guide.

There is no standard for transfer of load time for UPSs, but for many applications, such as computer or communications equipment, the load transfer time must be zero (i.e., the load is never interrupted). Therefore, the recommended assessment criterion is that if the load is interrupted during failure of the AC mains, whether under zero load current THD or high load current THD (e.g., 50 percent THD), the usefulness of the UPS is in question for most applications. The degradation (trip voltage decrease) of the trip point for the UPS with increasing load current THD should be no greater than 10 V for a 120-V UPS and 20 V for a 240-V UPS for most applications.

**Efficiency tests** measure the efficiency of the UPS under nonlinear load. Evaluation of test results is made on the degree of losses in the UPS with increasing load current THD, using Figure 17 as a guide.

**Heating tests** measure the temperature rise of the UPS under nonlinear load. The mechanical design of specific UPSs and their losses dictate the heating of the unit; due to considerable variability of these factors, no expected heating characteristics can be put forth. UL Standard 1778 (Table 4) can be used as an upper limit for UPS temperatures.

**Load support tests** measure the length of time for which rated load may be supported by the UPS while the unit has a nonlinear load. The degradation of load support time with modest- to high-load current THD (e.g., 0 to 20 percent) should be barely measurable. As an assessment of test results, it is suggested that if the load support time decreases by more than 10 percent, the UPS losses are excessive and the load support time sensitivity to load current THD is excessive. Figures 19 and 20 give a qualitative interpretation of the results of this test.

**Voltage regulation tests** measure the load bus voltage regulation and its total harmonic distortion while the UPS is under nonlinear load. Table 16 gives guidance for interpreting the results of this test.

**Isolation tests** measure the electrical isolation of the input and output busses of the UPS when impulses occur in either the supply or load circuit. Typical results of this test depend on whether the UPS design employs surge suppression and isolation transformers, and the quality of these components. Typical measured isolation figures range from 0 dB to -60 dB. Table 24 gives a qualitative assessment of the effectiveness of the UPS as an isolator.

## Recommendations

It is recommended that the following commercially available systems (manufacturer, model, model number) be tested in order to validate the test procedures developed:

- Best Fortress (950)
- Isoleg Isoguard (PWM-16-100-12-12-12-4-UU)
- Oneac ON Series (ON1300A-SO)
- Sola (54-216-19)
- Superior UPS (UPSY61012R)
- Topaz Powermaker (81100VR)
- Tripp-Lite MPS Series (MPS1200).

# References

## Cited References

- ANSI/UL 1778, *Uninterruptible Power Supply Equipment* (1991).
- ANSI/UL 1012, *Power Supplies* (1984).
- ANSI/UL 1012, *Power Supplies* (1991).
- CSI 16612-90, *Emergency Generating Equipment* (1990).
- EGSA Standard 1015, *Engine Driven Generator Sets Guideline Specifications for Emergency Standby* (1984).

## Uncited References

- Adimiya, G., F. Kovalev, and S. Florentsev, "Diagnostics for Uninterruptible Power Supply Sets," *Soviet Electrical Engineering* (English translation of *Elektrotekhnika*), vol 58, no. 10 (1987).
- ANSI/IEEE C84.1, *Voltage Ratings for Power Systems and Equipment* (1984).
- ANSI/IEEE 242, *Recommended Practice for Protection and Coordination of Industrial and Commercial Power Systems* (1974).
- ANSI/IEEE 399, *Recommended Practice for Industrial and Commercial Power System Analysis* (1982).
- ANSI/IEEE 446, *Recommended Practice for Emergency and Standby Power for Industrial and Commercial Applications* (1989).
- Delans, D., "Avoid Overestimating UPS Size," *Computer Technology Review* (1987).
- Federal Information Processing Standards (FIPS) Publication 94, *Guideline on Electrical Power for ADP Installations* (National Technical Information Service, United States Department of Commerce, 1978).
- Freund, A., "UPS Batteries—Testing and Maintenance," *Electrical Construction and Maintenance* (1990).
- Griffith, D. C., *Uninterruptible Power Supplies* (Marcel Dekker, 1989).
- Heydt, G. T., *Electric Power Quality* (Stars in a Circle Publications, 1991).

IEEE Standard 519, *Recommended Practices and Requirements for Harmonic Control in Electrical Power Systems* (1992).

McPhee, J., *The Effects of Electrical Power Variations on Computers: An Overview* (Government Printing Office, 1974)

NFPA Standard 110, *Emergency and Standby Power Systems* (NFPA, 1993).

Pregnitz, R., "Comparing Battery Back-Up Units," *Sixth Annual Applied Power Conference*, Dallas, TX, March 10-15, 1991.

Sachs, K., "New Developments in Low Impedance Rotary UPS Design," *Proceedings of the International Telecommunications Energy Conference*, (Intelec) Toronto, ON, Canada, 1986, pp 637-45.

## Glossary

**Electromagnetic interference (EMI):** Induced noise in circuits where the means of induction is electromagnetic (i.e., the spurious signal is electromagnetically induced rather than injected by ohmic means). EMI usually occurs at radio frequencies and is associated with radio frequency interference (RFI).

**Emergency power supply:** An electric power supply for temporary electric power service, usually through the use of a gasoline- or diesel-powered engine operating an electric generator. The difference between an emergency power supply and an uninterruptible power supply (UPS) is that a UPS includes an automatic transfer feature for transfer of the load to the auxiliary source upon interruption of the AC mains, and the UPS is generally intended to carry the load for a short period of time.

**Flicker:** Slow, low frequency ( $\ll 60$  Hz) voltage fluctuation at a distribution load bus. This phenomenon is often associated with arc furnaces and certain other industrial loads, and it may be associated with swinging of auxiliary generators. The phenomenon is quantified by the flicker factor ( $F$ ), which is defined as

$$F = \frac{|V_{high}| - |V_{low}|}{|V_{rated}|}$$

The flicker factor is often expressed in percent. When the flicker factor is zero, the bus voltage is steady and there is no flicker present.

**Harmonic:** Integer multiple frequency of a Fourier component of a signal. When a periodic signal is decomposed into its Fourier components, a Fourier series results, shown here for a load current  $i(t)$ ,

$$i(t) = \sum_{i=1}^{\infty} a_i \cos(i\omega_0 t + \phi_i)$$

Each term in the series is called a harmonic and the first term is called the fundamental. By this definition, there is no possibility of other than an integer multiple of the fundamental frequency; however, some power engineers loosely refer to any frequency as a harmonic. The most common load current harmonics are below the 19th harmonic of the fundamental.

**Isolation:** The separation of a load circuit from a supply circuit. For example, a common distribution transformer ohmically separates the load and supply circuits and provides isolation. In some cases, this isolation is inadequate and additional isolation is required to attenuate pulses, spikes, and other phenomena in the supply from reaching the load. Isolation may be quantified as the basic impulse level of the dielectric between the source and load circuits, or it may be the attenuation of harmonic voltages between the supply and load circuits. In the latter case, the isolation may be measured in decibels,

$$A(\omega) = 10 \log_{10} \frac{|V_{\text{sec}}(\omega)|}{|V_{\text{pri}}(\omega)|}$$

**Load support time:** The time for which an uninterruptible power supply can support 100 percent of the load.

**Power conditioning:** The processing, filtering, isolation, smoothing, and regulation of a supply bus voltage for the purpose of limiting and attenuating harmonics, spikes, sags, and other power quality problems. Power conditioners are commercially available in different sizes ranging from single phase in the 1.0 kVA range to more than 1 MVA.

**Power factor:** The ratio of active power in a circuit to the voltamperes,  $|V| |I|$ ,

$$pf = \frac{P}{|V| |I|}$$

The term leading power factor refers to current leading voltage (capacitive load), and lagging power factor refers to current lagging behind voltage (inductive load).

**Radio frequency interference (RFI):** Noise or induced-signal interference at frequencies in the band 100 kHz to 1000 MHz. The term RFI is frequently applied to all noise with a radio frequency spectrum.

**Rotating UPS:** An uninterruptible power supply that uses a rotating engine/generator or a motor/generator set.

**Sag:** A low bus voltage condition. The duration of the sag is more than 1 cycle, but generally less than a few seconds.

**Spike:** A rapid, momentary rise in bus voltage. The spike duration is less than 1 cycle.

**Static UPS:** An uninterruptible power supply that does not include any rotating elements (i.e., no motor, gasoline engine, or generator). These devices are usually designed using batteries as the energy storage mechanism and solid state devices to convert DC to AC for operation in the emergency power mode and AC to DC to recharge the batteries.

**Total harmonic distortion (THD):** An engineering index applied to AC voltages or currents. The index describes how much harmonic voltage or current is contained in the signal. The THD is defined as

$$THD = \frac{\sqrt{\sum_{k=2}^{\infty} I_k^2}}{I_1}$$

In this expression, the harmonic components of the load current  $I$  are indicated by a subscript  $k$ . The indicated definition is written for current but may also be used for bus voltage THD with the simple substitution of  $V$  for  $I$ .

**Uninterruptible power supply (UPS):** An electric power source that is designed to have output power to supply a load even if the input power is interrupted (outaged). A UPS differs from an emergency standby power source in that a UPS is designed to carry the load for a short period of time (generally from less than a second to about an hour), whereas an emergency power source is designed to carry a load on a temporary basis for a longer period of time. Also, a UPS has an automatic transfer feature for transfer of the load to the auxiliary source upon interruption of the AC mains.

**Voltage regulation:** An electrical index that indicates the deviation of the bus voltage magnitude from the rated value,

$$\text{Voltage regulation} = \frac{|V_{\text{actual}}| - |V_{\text{rated}}|}{|V_{\text{rated}}|}$$

The voltage regulation is often expressed as a percentage.

## Abbreviations and Acronyms

A	Isolation in decibels (dB)
AC	Alternating current
ANSI	American National Standards Institute
BNS	British National Standard
BS	British Standard
C	Capacitance
cfm	Cubic feet per minute
CSI	Construction Specification Institute
dB	Decibels
DC	Direct current
EGSA	Electrical Generating Systems Association
EMI	Electromagnetic interference
EN	European Norm
F	Flicker
Hz	Hertz
I, i(t)	Current
IEC	International Electrotechnical Commission
IEEE	Institute of Electrical and Electronics Engineers
J	Joule
L	Inductance
LAN	Local area network
MOV	Metal oxide varistor
P	Power (active power)

---

pf	Power factor
PWM	Pulse width modulated
Q	Reactive power
R	Resistor
<i>R</i>	Regulation
RFI	Radio frequency interference
THD	Total harmonic distortion
UL	Underwriters' Laboratories
UPS	Uninterruptible power supply
V, v(t)	Voltage
VLSI	Very large scale integration
Z	Impedance
$\omega$	Frequency (rad/s)

# USACERL DISTRIBUTION

Chief of Engineers  
 ATTN: CEHEC-IM-LH (2)  
 ATTN: CEHEC-IM-LP (2)  
 ATTN: CECG  
 ATTN: CECC-P  
 ATTN: CECW  
 ATTN: CECW-O  
 ATTN: CECW-P  
 ATTN: CECW-PR  
 ATTN: CEMP  
 ATTN: CEMP-E  
 ATTN: CEMP-C  
 ATTN: CEMP-M  
 ATTN: CEMP-R  
 ATTN: CERD-C  
 ATTN: CERD-ZA  
 ATTN: CERD-L  
 ATTN: CERD-M  
 ATTN: CERM  
 ATTN: DAEN-ZC  
 ATTN: DAIM-FDP

CECPW 22310-3862  
 ATTN: CECPW-EE  
 ATTN: CECPW-FT  
 ATTN: CECPW-ZC  
 ATTN: DET III 79906

US Army Engr District  
 ATTN: Library (40)

US Army Engr Division  
 ATTN: Library (12)

US Army Europe  
 ATTN: AEAEN-EH 09014  
 ATTN: AEAEN-ODCS 09014  
 29th Area Support Group  
 ATTN: AERAS-FA 09054  
 100th Support Group  
 ATTN: AETT-EN-DPW 09114  
 222d Base Battalion  
 ATTN: AETV-BHR-E 09034  
 235th Base Support Battalion  
 ATTN: Unit 28614 Ansbach 09177  
 293d Base Support Battalion  
 ATTN: AEUSG-MA-AST-WO-E 09086  
 409th Support Battalion (Base)  
 ATTN: AETT-G-DPW 09114  
 412th Base Support Battalion 09630  
 ATTN: Unit 31401  
 Frankfurt Base Support Battalion  
 ATTN: Unit 25727 09242  
 CMTG Hohenfels 09173  
 ATTN: AETT-H-DPW  
 Mainz Germany 09185  
 ATTN: BSB-MZ-E  
 21st Support Command  
 ATTN: DPW (9)  
 US Army Berlin  
 ATTN: AEBA-EH 09235  
 ATTN: AEBA-EN 09235  
 SETAF  
 ATTN: AESE-EN-D 09613  
 ATTN: AESE-EN 09630  
 Supreme Allied Command  
 ATTN: ACSGEB 09703  
 ATTN: SHIHB/ENGR 09705

INSCOM  
 ATTN: IALOG-I 22060  
 ATTN: IAV-DPW 22186

USA TACOM 48397-5000  
 ATTN: AMSTA-XE

Defense Distribution Region East  
 ATTN: DDRE-WI 17070

HQ XVIII Airborne Corps 28307  
 ATTN: AFZA-DPW-EE

4th Infantry Div (MECH) 80913-5000  
 ATTN: AFZC-FE

US Army Materiel Command (AMC)  
 Alexandria, VA 22333-0001  
 ATTN: AMCEN-F  
 Installations: (19)

FORSKOM  
 Forts Gillem & McPherson 30330  
 ATTN: FCEN  
 Installations: (23)

6th Infantry Division (Light)  
 ATTN: APVR-DE 99505  
 ATTN: APVR-WF-DE 99703

TRADOC  
 Fort Monroe 23651  
 ATTN: ATBO-G  
 Installations: (20)

Fort Belvoir 22060  
 ATTN: CETEC-IM-T  
 ATTN: CECC-R 20314-1000  
 ATTN: Engr Strategic Studies Ctr  
 ATTN: Water Resources Support Ctr  
 ATTN: Australian Liaison Office

USA Natick RD&E Center 01760  
 ATTN: STRNC-DT  
 ATTN: DRDNA-F

US Army Materials Tech Lab  
 ATTN: SLCMT-DPW 02172

USARPAC 96858  
 ATTN: DPW  
 ATTN: APEN-A

SHAPE 09705  
 ATTN: Infrastructure Branch LANDA

Area Engineer, AEDC-Area Office  
 Arnold Air Force Station, TN 37389

HQ USEUCOM 09128  
 ATTN: ECJ4-LIE

AMMRC 02172  
 ATTN: DRXMR-AF  
 ATTN: DRXMR-WE

CEWES 39180  
 ATTN: Library

CECRL 03755  
 ATTN: Library

USA AMCOM  
 ATTN: Facilities Engr 21719  
 ATTN: AMSMC-EH 61299  
 ATTN: Facilities Engr (3) 85613

USAAARMC 40121  
 ATTN: ATZIC-EHA

Military Traffic Mgmt Command  
 ATTN: MTEA-GB-EHP 07002  
 ATTN: MT-LOF 20315  
 ATTN: MTE-SU-FE 28461  
 ATTN: MTW-IE 94626

Fort Leonard Wood 65473  
 ATTN: ATSE-DAC-LB (3)  
 ATTN: ATZA-TE-SW  
 ATTN: ATSE-CFLO  
 ATTN: ATSE-DAC-FL

Military Dist of WASH  
 Fort McNair  
 ATTN: ANEN 20319

USA Engr Activity, Capital Area  
 ATTN: Library 22211

US Army ARDEC 07806  
 ATTN: SMCAR-ISE

Engr Societies Library  
 ATTN: Acquisitions 10017

Defense Nuclear Agency  
 ATTN: NADS 20305

Defense Logistics Agency  
 ATTN: DLA-WI 22304

Walter Reed Army Medical Ctr 20307

National Guard Bureau 20310  
 ATTN: NGB-ARI

US Military Academy 10996  
 ATTN: MAEN-A  
 ATTN: Facilities Engineer  
 ATTN: Geography & Envr Engr

Naval Facilities Engr Command  
 ATTN: Facilities Engr Command (8)  
 ATTN: Division Offices (11)  
 ATTN: Public Works Center (8)  
 ATTN: Naval Constr Battalion Ctr 93043  
 ATTN: Naval Facilities Engr Service Center 93043-4328

8th US Army Korea  
 ATTN: DPW (12)

USA Japan (USARJ)  
 ATTN: APAJ-EN-ES 96343  
 ATTN: HONSHU 96343  
 ATTN: DPW-Okinawa 96376

416th Engineer Command 60623  
 ATTN: Gibson USAR Ctr

US Army HSC  
 Fort Sam Houston 78234  
 ATTN: HSLO-F  
 Fitzsimons Army Medical Ctr  
 ATTN: HSHG-DPW 80045

Tyndall AFB 32403  
 ATTN: HQAFCEA Program Ofc  
 ATTN: Engrg & Srvc Lab

USA TSARCOM 63120  
 ATTN: STSAS-F

American Public Works Assoc. 64104-1806

US Army Envr Hygiene Agency  
 ATTN: HSHB-ME 21010

US Gov't Printing Office 20401  
 ATTN: Rec Sec/Deposit Sec (2)

Nat'l Institute of Standards & Tech  
 ATTN: Library 20899

Defense Tech Info Center 22304  
 ATTN: DTIC-FAB (2)

282  
 10/94