



**US Army Corps  
of Engineers**  
Waterways Experiment  
Station

Technical Report HL-94-16  
November 1994

# Ship Navigation Simulation Study, Los Angeles Harbor, Los Angeles, California

by *J. Christopher Hewlett*

**DTIC**  
**ELECTE**  
JAN 06 1995  
**S** **D**  
**G**

DTIC QUALITY INSPECTED 3

Approved For Public Release; Distribution Is Unlimited

19950104 034

Prepared for U.S. Army Engineer District, Los Angeles

The contents of this report are not to be used for advertising, publication, or promotional purposes. Citation of trade names does not constitute an official endorsement or approval of the use of such commercial products.



PRINTED ON RECYCLED PAPER

# Ship Navigation Simulation Study, Los Angeles Harbor, Los Angeles, California

by J. Christopher Hewlett  
U.S. Army Corps of Engineers  
Waterways Experiment Station  
3909 Halls Ferry Road  
Vicksburg, MS 39180-6199

|                     |                                     |
|---------------------|-------------------------------------|
| Accession For       |                                     |
| NTIS CRA&I          | <input checked="" type="checkbox"/> |
| DTIC TAB            | <input type="checkbox"/>            |
| Unannounced         | <input type="checkbox"/>            |
| Justification ..... |                                     |
| By .....            |                                     |
| Distribution /      |                                     |
| Availability Codes  |                                     |
| Dist                | Avail and / or<br>Special           |
| A-1                 |                                     |

Final report

Approved for public release; distribution is unlimited



**US Army Corps  
of Engineers**  
Waterways Experiment  
Station

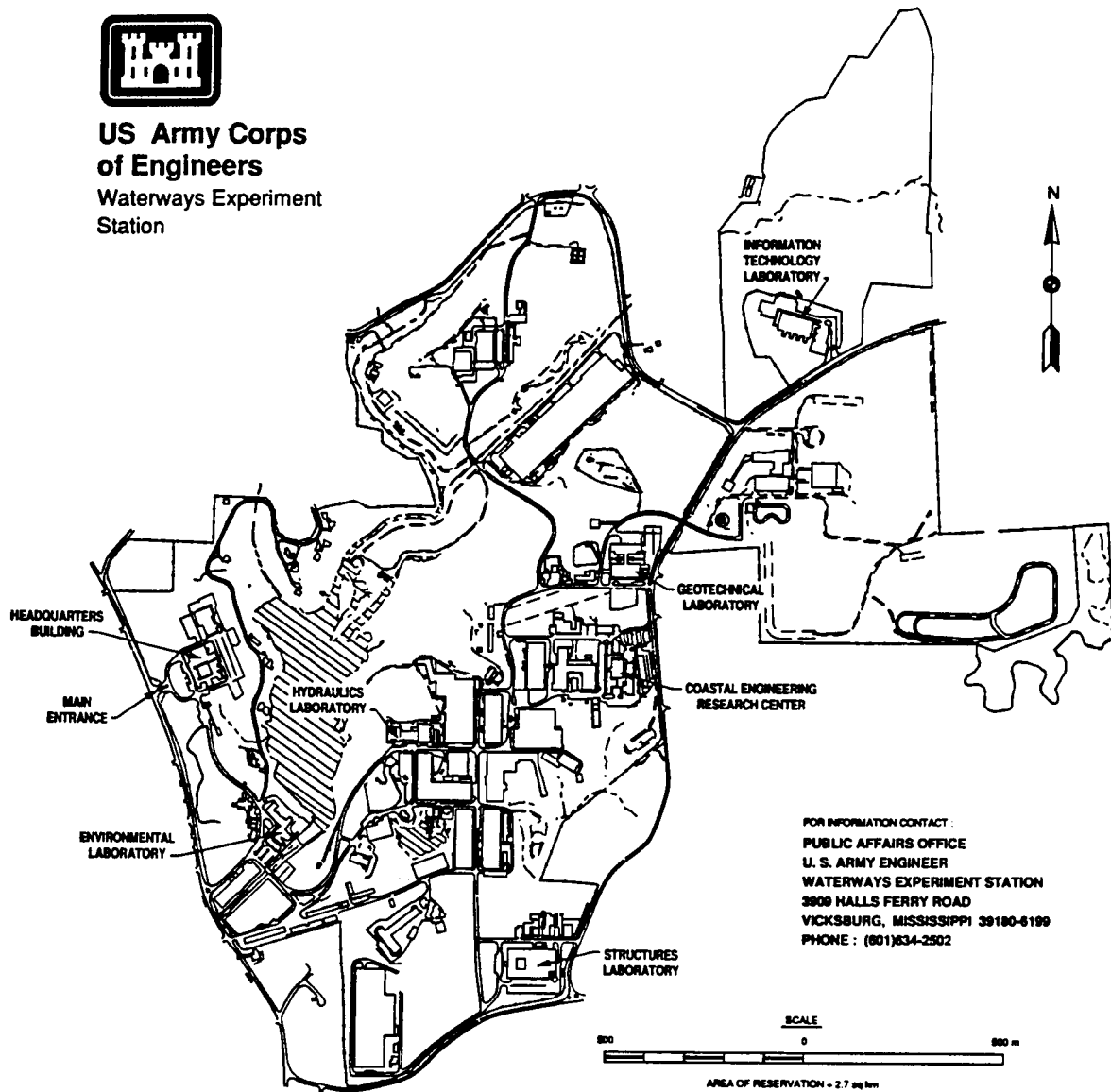

FOR INFORMATION CONTACT:  
PUBLIC AFFAIRS OFFICE  
U. S. ARMY ENGINEER  
WATERWAYS EXPERIMENT STATION  
3808 HALLS FERRY ROAD  
VICKSBURG, MISSISSIPPI 39180-6199  
PHONE : (601)634-2502

### Waterways Experiment Station Cataloging-in-Publication Data

Hewlett, J. Christopher.

Ship Navigation Simulation Study, Los Angeles Harbor, Los Angeles, California / by J. Christopher J. Hewlett ; prepared for U.S. Army Engineer District, Los Angeles.

361 p. : ill. ; 28 cm. -- (Technical report ; HL-94-16)

Includes bibliographic references.

1. Navigation -- California -- Los Angeles -- Computer simulation. 2. Channels (Hydraulic engineering) -- California -- Los Angeles. 3. Ships -- Maneuverability -- Computer simulation. 4. Harbors -- California -- Los Angeles -- Design and construction. I. United States. Army. Corps of Engineers. Los Angeles District. II. U.S. Army Engineer Waterways Experiment Station. III. Hydraulics Laboratory (U.S.) IV. Title. V. Series: Technical report (U.S. Army Engineer Waterways Experiment Station) ; HL-94-16.

TA7 W34 no.HL-94-16

# Contents

---

|   |    |
|---|----|
| Preface .....   | v  |
| Conversion Factors, Non-SI to SI Units of Measurement ..... | vi |
| 1—Introduction .....  | 1  |
| Background .....  | 1  |
| Scope and Objectives .....                                  | 1  |
| 2—Design Conditions and Data Development .....              | 9  |
| Design Ships and Maneuvering Scenarios .....                | 9  |
| Tugs .....  | 11 |
| Environmental Factors .....                                 | 11 |
| Simulation wind/current/wave test conditions summary .....  | 11 |
| Currents .....  | 12 |
| Wind .....  | 13 |
| Current vector plots .....                                  | 13 |
| Waves .....   | 13 |
| 3—Study Results .....                                       | 17 |
| Pilot Testing and Simulation Validation .....               | 17 |
| Two-way Containership Tests .....                           | 18 |
| Full length runs .....                                      | 18 |
| Angels gate .....   | 19 |
| Channel bend .....  | 19 |
| Pier 400 .....  | 19 |
| Constriction point .....                                    | 20 |
| Containership slip .....                                    | 20 |
| Pilot questionnaire results .....                           | 21 |
| Passing ship effects .....                                  | 21 |
| One-way POLA Tests .....                                    | 24 |
| Pier 300/coal dock .....                                    | 24 |
| Pier 400 West .....   | 25 |
| Pier 400 East .....   | 26 |
| Pilot questionnaire results .....                           | 27 |
| Passing ship effects .....                                  | 27 |
| NED One-way Tests .....                                     | 28 |
| NED 2 .....   | 28 |
| NED 2-3 .....   | 29 |

|  |    |
|--|----|
| Pilot questionnaire results . . . . .                            | 30 |
| Passing ship effects . . . . .                                   | 30 |
| 4—Conclusions and Recommendations . . . . .                      | 31 |
| POLA I . . . . .   | 31 |
| Study conclusions . . . . .                                      | 31 |
| Design recommendations . . . . .                                 | 31 |
| POLA II . . . . .  | 42 |
| Study conclusions . . . . .                                      | 42 |
| Design recommendations . . . . .                                 | 42 |
| NED 2 . . . . .  | 43 |
| Study conclusions . . . . .                                      | 43 |
| Design recommendations . . . . .                                 | 43 |
| NED 2-3 . . . . .  | 43 |
| Study conclusions . . . . .                                      | 43 |
| Design recommendations . . . . .                                 | 44 |
| NED 2-5 . . . . .  | 44 |
| Study conclusions . . . . .                                      | 44 |
| Design recommendations . . . . .                                 | 45 |
| General Study Conclusions . . . . .                              | 45 |
| References . . . . .   | 47 |
| Scenario - Trackplot Reference Key                               |    |
| Plates 1-285   |    |
| Appendix A: MSI Learning Center and Simulator Facility . . . . . | A1 |
| Appendix B: Pilot Questionnaire . . . . .                        | B1 |
| SF 298   |    |

# Preface

---

This investigation was performed by the Hydraulics Laboratory (HL), U.S. Army Engineer Waterways Experiment Station (WES), for the U.S. Army Engineer District, Los Angeles. The simulations were conducted on contract DACW39--93-C-0079 with Marine Safety International, Inc. (MSI), at their simulator training facility in Newport, RI. The study was conducted during the period May 1993 through May 1994.

Contract management with MSI and analysis of simulation results were the responsibility of Mr. J. Christopher Hewlett, Navigation Branch, Waterways Division, HL, under the general direction of Messrs. Frank A. Herrmann, Jr., Director, HL; Richard A. Sager, Assistant Director, HL; Dr. Larry L. Daggett, Acting Chief, Waterways Division and Navigation Branch.

Acknowledgment is made to the study manager at MSI, Mr. Todd Schreiber, who managed the development of simulator databases, scheduled and conducted the testing program, reduced and submitted simulation data and results, and assisted in analysis aimed at preparation of this report. Acknowledgment is also made to all members of the staff at the MSI Kingspoint, NY, headquarters as well as the Newport, RI, simulator training facility. Vessel trackplots presented in this report were produced by the contractor at Kingspoint, NY. Acknowledgment is made to Ms. Deborah Wilkinson, contract technician at WES, who added identification labels to the trackplots for presentation.

The responsible engineers at Los Angeles District during the study were Ms. Jane Grandon, Coastal Engineering Section, and Mr. Art Shak, Chief, Coastal Engineering Section. Acknowledgment is made to Mr. John Foxworthy who was the simulation study point of contact for the Port of Los Angeles. Also at the Port of Los Angeles, thanks goes to Capt. Ward Pearce, Los Angeles pilot, for arranging participation of professional pilots in the simulation study.

At the time of publication of this report, Director of WES was Dr. Robert W. Whalin. Commander was COL Bruce K. Howard, EN.

*The contents of this report are not to be used for advertising, publication, or promotional purposes. Citation of trade names does not constitute an official endorsement or approval of the use of such commercial products.*

# Conversion Factors, Non-SI to SI Units of Measurement

---

Non-SI units of measurement used in this report can be converted to SI units as follows:

| Multiply              | By        | To Obtain         |
|-----------------------|-----------|-------------------|
| feet                  | 0.3048    | meters            |
| tons                  | 1016.046  | kilograms         |
| miles (U.S. statute)  | 1.609347  | kilometers        |
| knots (international) | 0.5144444 | meters per second |

# 1 Introduction

---

## Background

The Port of Los Angeles (POLA) and the U.S. Army Engineer District, Los Angeles (the District) have formulated separate plans for the development of new port facilities within the municipal limits of Los Angeles, California in San Pedro Bay. The District requested the U.S. Army Waterways Experiment Station (WES) to conduct a ship simulation study on the navigation aspects of the plans. The simulation tests were performed, under contract to WES, by Marine Safety International, Inc. (MSI) at their Newport, Rhode Island Ship-handling Learning Center. This simulator training facility is composed of four separate simulators of different configurations, each of which can be used in an interactive mode with any of the others. During the Los Angeles study all the simulators were used at one time or another for the maneuvering tests. A description of the training facility with figures is presented in Appendix A.

## Scope and Objectives

The existing condition of the study area is shown on Figure 1.<sup>1</sup> The POLA has developed a two-stage plan for new construction, POLA I and POLA II, shown on Figures 2 & 3, respectively.<sup>2</sup> The POLA II stage is proposed as the final configuration of the port to be constructed a number of years after completion of POLA I. The District has developed a testing plan consisting of four separate channel increments. This plan is known as the National Economic Development (NED) plan and is based on the District's analysis of U.S. economic interests in the study area. Figure 4 shows NED increment 2. Figure 5 shows NED increment 3 which constitutes deepening and enlarging increment 2 and adding South Basin. Figure 6 shows the final configuration of the NED plan which includes the previous increments and the addition of increments 4 and 5. While the NED channels will not be built, they were tested in the simulation study to determine the required safe

---

<sup>1</sup> A table of factors for converting non-SI units of measurement to SI units is presented on page vi.

<sup>2</sup> Trackplot plates depict the POLA I channel extending as far seaward as the POLA II Channel.

dimensions and layout for the NED plan which will be used to aid the District in establishing a Project Cost-sharing Agreement with the POLA. There were two primary objectives for the simulation study:

- a.* Check the navigation safety of the two POLA plan stages and make design recommendations if indicated by the simulation tests.
- b.* Recommend channel configurations for the NED channels based on the navigation requirements of the NED design ships.

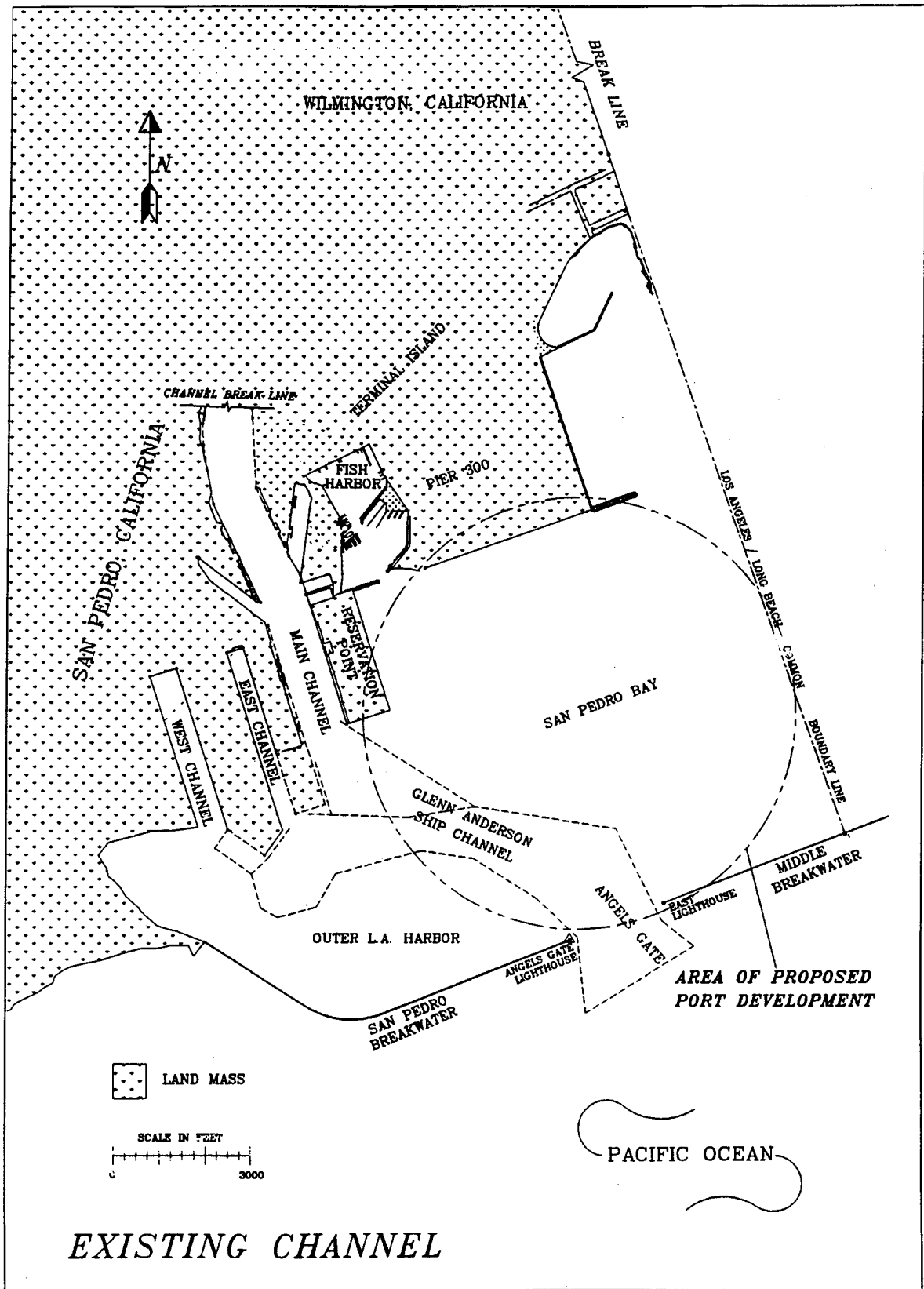

Figure 1. Existing channel study area

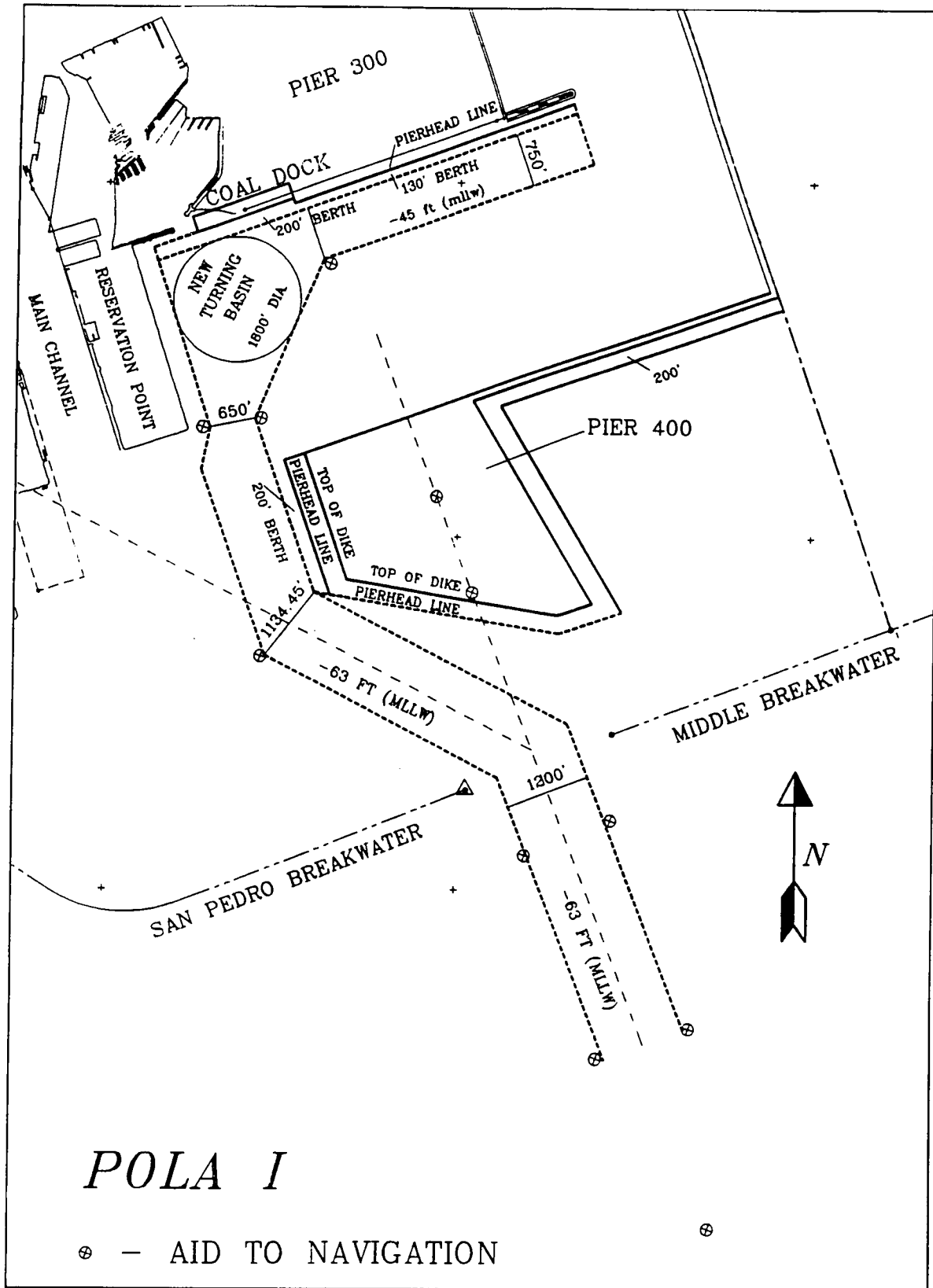

Figure 2. POLA I - Proposed channel

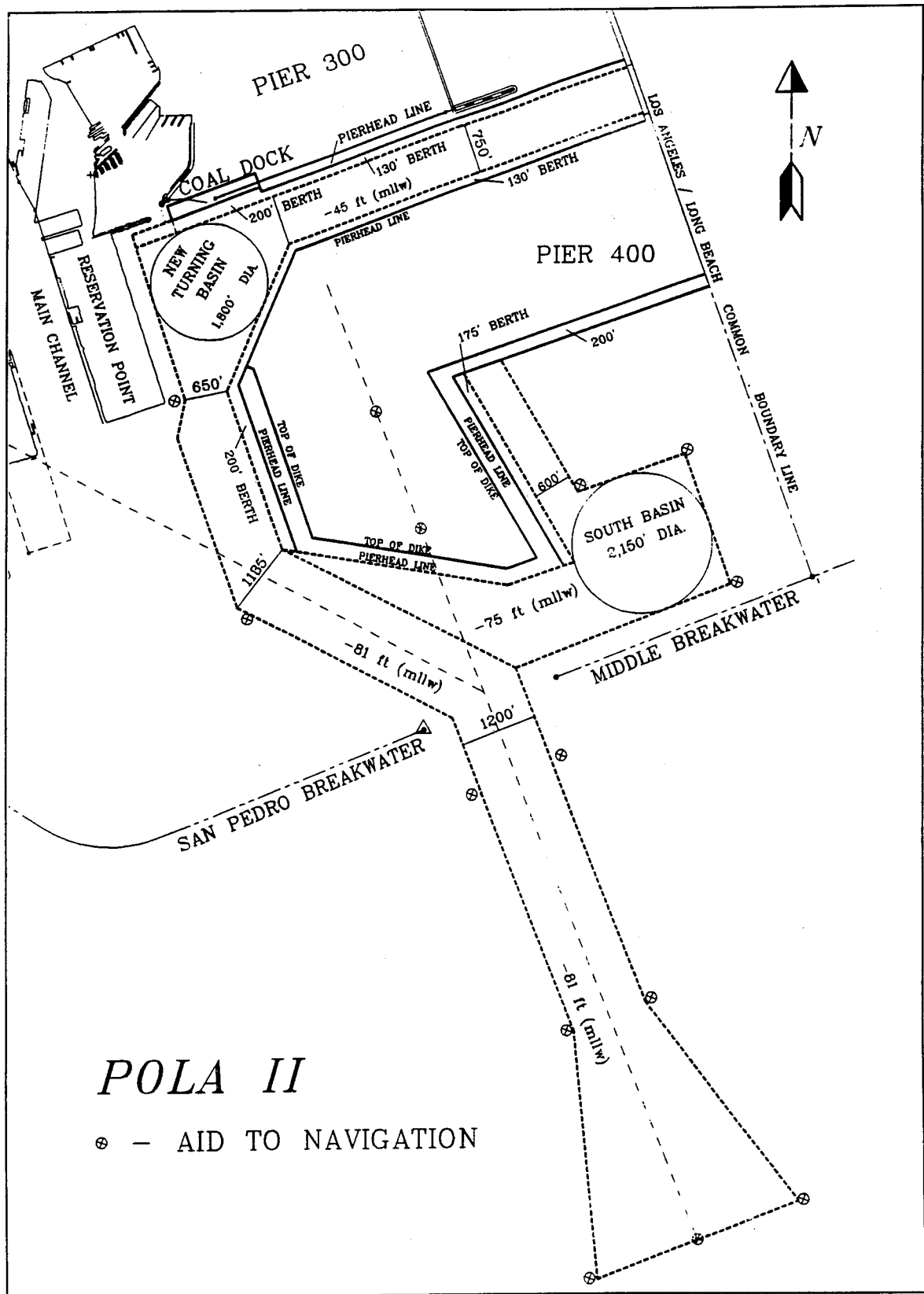

Figure 3. POLA II - Proposed channel

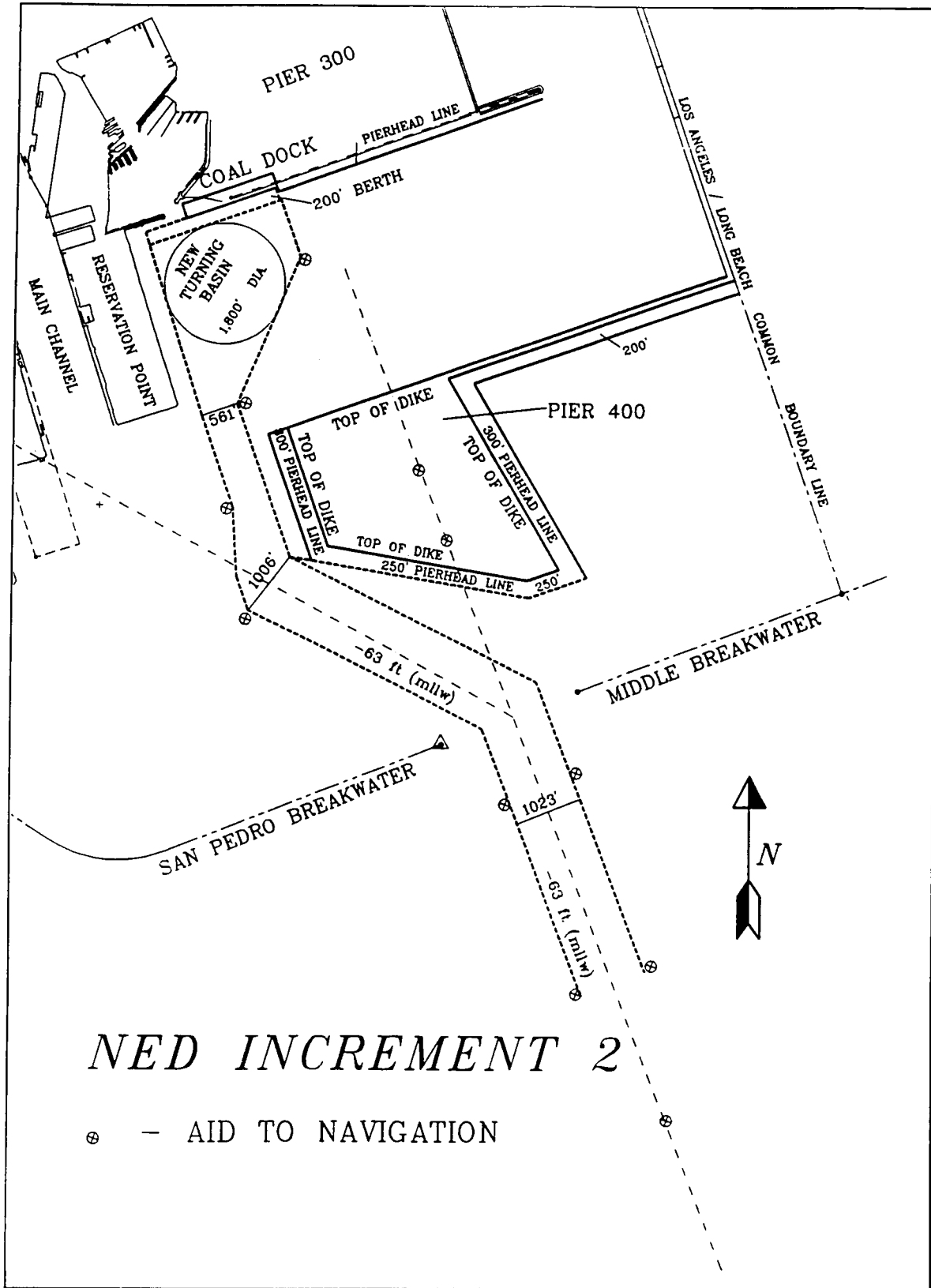

Figure 4. NED 2 - Proposed channel

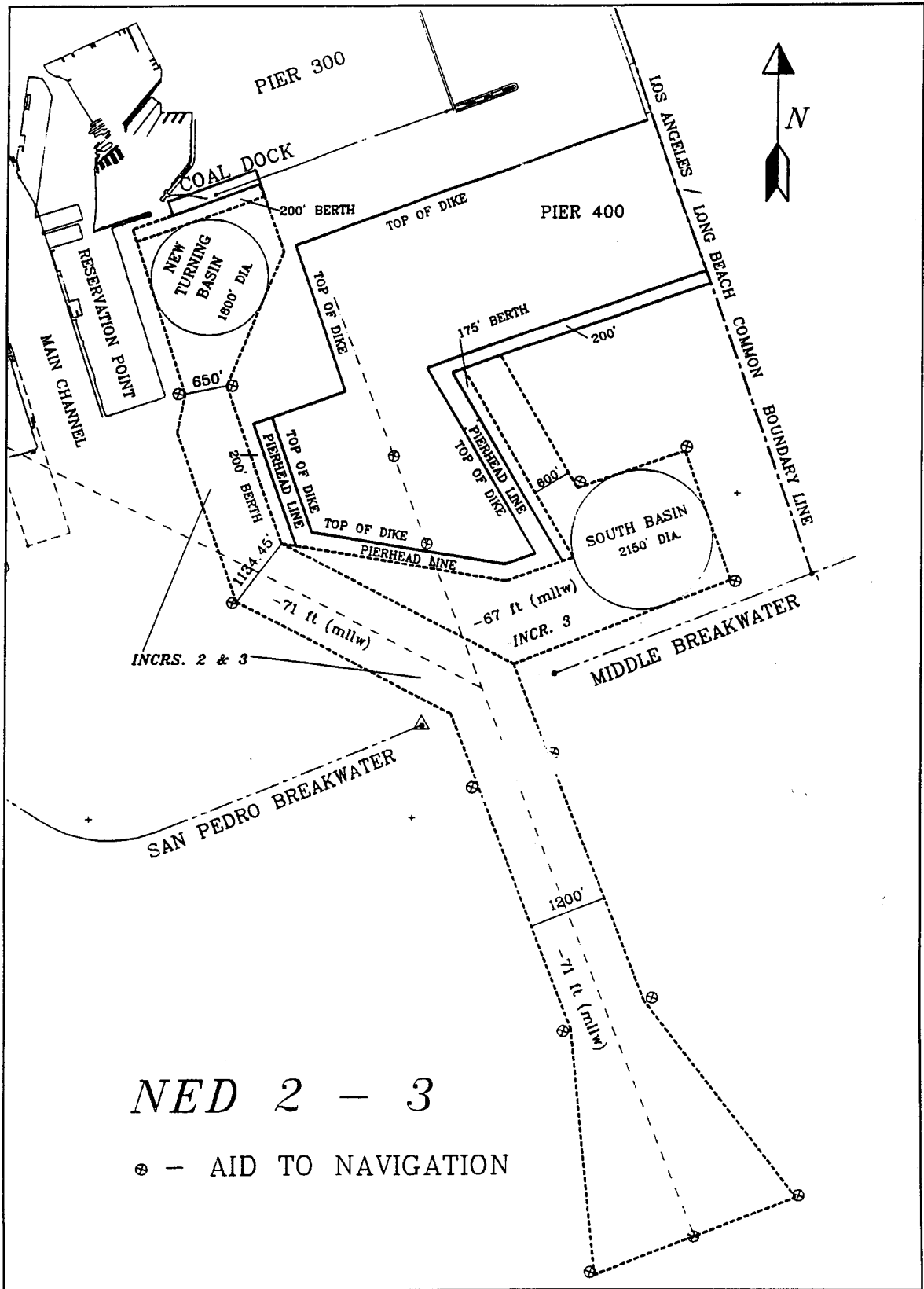

Figure 5. NED 2-3 - Proposed channel

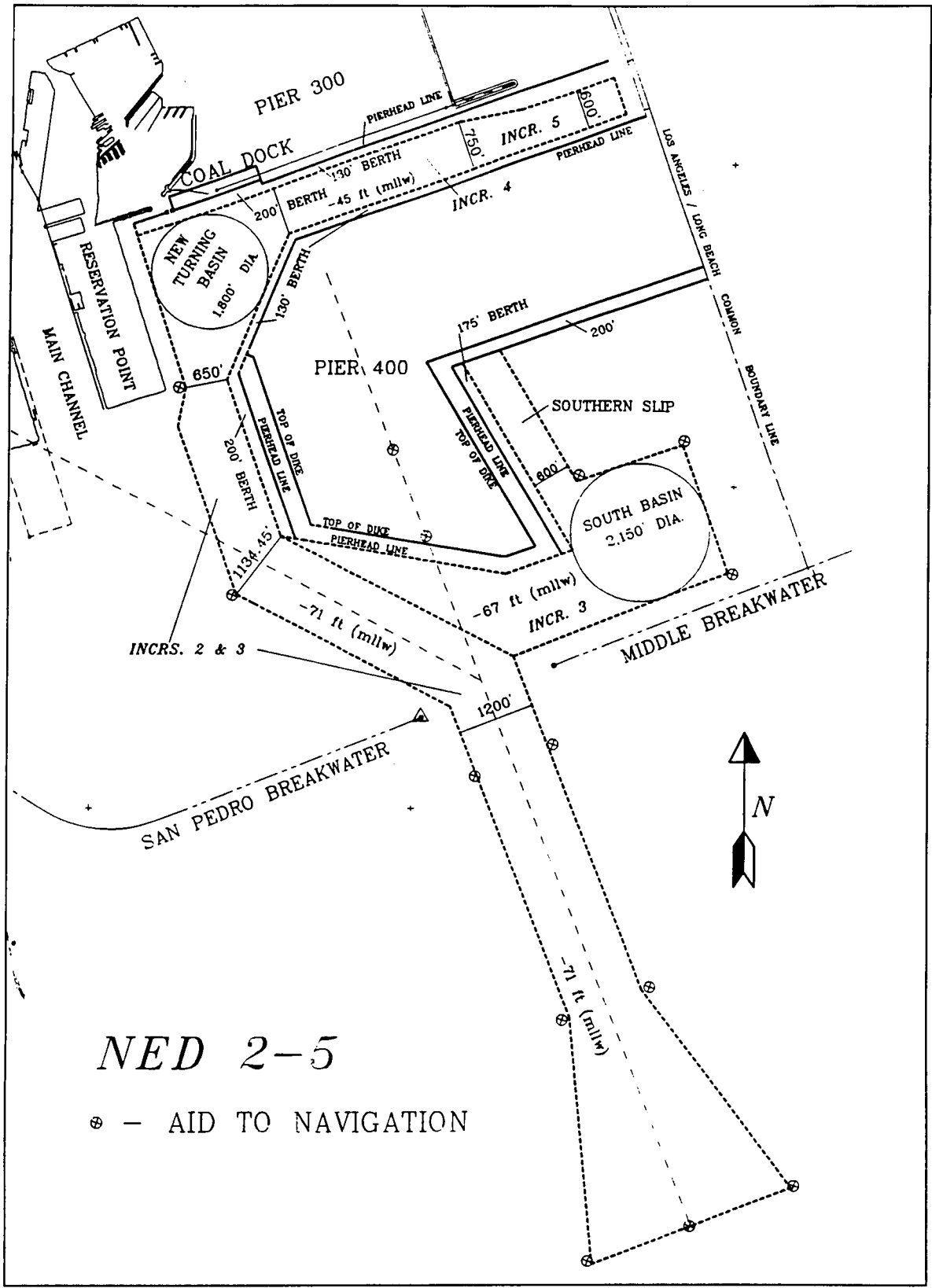

Figure 6. NED 2-5 - Proposed channel

## 2 Design Conditions and Data Development

---

### Design Ships and Maneuvering Scenarios

The difference between the POLA and NED plans is due to federal requirements to follow guidelines for water resource development projects. The economic projections stemming from the implementation of these guidelines (for the NED plan) resulted in dissimilar plans and design ships than those developed by the POLA. The study included two main types of navigation scenarios: two-way traffic with containerships and one-way traffic with bulk carriers and tankers. The 5K TEU<sup>1</sup> containership tested in the simulations is the type known as "Post-Panamax," which presently calls at the Port of Los Angeles. The tankers and bulk carriers tested are much larger than those frequenting the harbor at present and range from 250K DWT<sup>2</sup> to 325K DWT. All numerical models of the design ships were developed by a naval architect on contract to WES (Ankudinov 1994). Table 1 summarizes the design ships tested in the simulation study. Table 2 shows the simulator scenarios with the different combinations of design conditions.

| Ship Code | Type of Vessel               | Length Overall | Beam   | Design Draft |
|-----------|------------------------------|----------------|--------|--------------|
| C10       | 5K TEU Containership         | 950 ft         | 129 ft | 41 ft        |
| T1        | 325K DWT Tanker              | 1210 ft        | 193 ft | 73 ft        |
| T2        | 265K DWT Tanker/Bulk Carrier | 1110 ft        | 173 ft | 68 ft        |
| T3        | 325K DWT Tanker              | 1158 ft        | 190 ft | 71 ft        |
| T4        | 265K DWT Tanker              | 1092 ft        | 178 ft | 66 ft        |
| BC        | 250K DWT Bulk Carrier        | 1089 ft        | 165 ft | 66 ft        |

<sup>1</sup> TEU - Twenty-foot Equivalent Units

<sup>2</sup> DWT - Deadweight-tons

| Plan    | Water Depth (ft)   | Vessel - Draft (ft) | Traffic  | Harbor Destination |
|---------|--------------------|---------------------|----------|--------------------|
| POLA I  | 63/45 <sup>1</sup> | C10 - 41            | TWO-WAY  | PIER 300           |
| POLA II | 81/45 <sup>1</sup> | C10 - 41            | TWO-WAY  | PIER 300/400N      |
| NED 2-5 | 72/45 <sup>1</sup> | C10 - 41            | TWO-WAY  | PIER 300/400N      |
| POLA I  | 63 <sup>2</sup>    | T1 - 57             | ONE-WAY  | PIER 400W          |
| POLA I  | 63 <sup>2</sup>    | INBOUND T2 - 44.5   | ONE-WAY  | COAL DOCK          |
|         |                    | OUTBOUND T2 - 57    |          |                    |
| POLA II | 81 <sup>2</sup>    | T1 - 73             | INBOUND  | PIER 400W          |
| POLA II | 81 <sup>2</sup>    | T2 - 68             | OUTBOUND | COAL DOCK          |
| POLA II | 81/75 <sup>3</sup> | INBOUND T2 - 68     | ONE-WAY  | PIER 400E          |
|         |                    | OUTBOUND T2 - 44.5  |          |                    |
| NED 2   | 66 <sup>2</sup>    | BC - 61.5           | OUTBOUND | COAL DOCK          |
| NED 2-3 | 74 <sup>2</sup>    | T3 - 69             | INBOUND  | PIER 400W          |
| NED 2-3 | 74/70 <sup>3</sup> | INBOUND T4 - 65     | ONE-WAY  | PIER 400E          |
|         |                    | OUTBOUND T2 - 44.5  |          |                    |

<sup>1</sup> Depth of main channel/depth of containership slip  
<sup>2</sup> Depth of main channel  
<sup>3</sup> Depth of main channel/depth of south channel

One-way traffic for the NED 2-5 channel (Figure 6) was not independently tested because conditions in the main and south portions of the channel remain essentially the same as in the NED 2-3 channel (Figure 5). The only difference is the inclusion of the 45-ft containership channel between Piers 300 and 400, an addition which does not significantly affect currents in other parts of the channel (Wang, 1994). The channel depths and vessel drafts for the one-way NED tests are based on design changes which took place after completion of Phase 1 of the simulation tests<sup>1</sup>. In these changes the District specified the vessels to have a 7% underkeel clearance for a tide level of +3 ft (mllw) and have a 3% trim by the stern. This signifies that for the BC, T3 and T4 design ships in Table 2 the bow draft was 3% less than the stern draft shown. Although the feasibility design changes were small, it was advisable to incorporate them because their effect on ship handling was unknown before

<sup>1</sup> CESPL-ED-DC memorandum dated 20 December 1993, subject: Los Angeles Harbor, Feasibility Study Changes Affecting Ship Simulation Study. Prior authorization for implementation of data base changes was granted via telephone conversation 18 October 1993.

simulation. For the POLA tests the original ships were used with a minimum 10% underkeel clearance.

The scenarios listed in Table 2 represent the basic ship/channel combinations for the study. It should be noted that the two-way simulations involved two interactive ships, independently piloted, navigating the channel in opposite directions. The two-way tests were conducted as a series of shorter runs to investigate meeting/passing maneuvers in different parts of the channel.

## **Tugs**

During the tests four simulated tugboats were available for use by the pilots. The four boats were specified on the simulator to closely match tugs which actually operate in Los Angeles Harbor and the pilots referred to them by name during the simulations. Two 5000 horse-power (HP) and two 3500 HP tugs comprised the available complement. One of the 5000 HP tugs was the type known as a "tractor tug" which can operate with significant force at much more oblique angles than the traditional type of tug. This particular tug was usually used by the pilots at the stern of the design vessels for slowing down the ship (with the assumption of line connection rather than hull contact). In most simulation scenarios all four of the tugs were used with their positions, angle of attack and power controlled at the request of the Los Angeles pilot at the con.

## **Environmental Factors**

### **Simulation wind/current/wave test conditions summary**

Table 3 summarizes the environmental test conditions which were used in the simulator study. Two prominent wind and swell combinations were used for the simulation tests: (a) Southeast (SE) wind at 20 knots with waves coming generally from the same direction and (b) West-southwest (WSW) wind at 20 knots also with waves from the same general direction. A 3-dimensional numerical model developed by the WES generated the current data for the simulations (Wang 1994). The wave data were obtained from a short wave physical model developed at WES (Bottin and Tolliver 1989). Another distinct set of conditions was used primarily for validation of the numerical current model. This was the "base" condition which used actual wind data recorded during prototype current measurement in Los Angeles Harbor. Although the wind varied over time for this condition, the primary direction was southwesterly (SW). The base condition was used in preliminary phase 1 sensitivity testing and again in a few of the phase 2 tests, but was dropped from the test program when it proved to be less critical than the WSW and SE wind directions. Simulator tests were run for both maximum ebb and flood currents.

**Table 3  
Simulation Test Conditions**

| Condition | Wind        | Tide  | Incident Waves at Sea Buoy |           |        |
|-----------|-------------|-------|----------------------------|-----------|--------|
|           |             |       | Height                     | Direction | Period |
| Base (SW) | (Wang 1994) | Flood | 10 ft                      | 154 deg.  | 15 SEC |
| Base (SW) | (Wang 1994) | Ebb   | 10 ft                      | 154 deg.  | 15 SEC |
| WSW       | WSW, 20 KTS | Flood | 12 ft                      | 231 deg.  | 15 SEC |
| WSW       | WSW, 20 KTS | Ebb   | 12 ft                      | 231 deg.  | 15 SEC |
| SE        | SE, 20 KTS  | Flood | 10 ft                      | 154 deg.  | 15 SEC |
| SE        | SE, 20 KTS  | Ebb   | 10 ft                      | 154 deg.  | 15 SEC |

### Currents

Generally, currents in the Los Angeles Harbor are small and not of primary navigation concern. This is true in the existing channel and, based on the current modeling study, will remain true for the proposed channels. An exception to this rule is in the vicinity of Angels Gate (Figure 1). The significance of the current in this area is predominantly due to its direction relative to the channel because its magnitude is relatively small. The numerical current model used for generation of current data (Wang 1994) was developed with three depth layers. The current data used in the simulation tests were obtained by vectorially averaging the current vectors from the three vertical layers. These depth-averaged currents approximated the "total" current effect on the ship's hull.

Six different channel design cases were run in the numerical current model. The channel depth and geometry for these cases are shown on Figures 1 - 6. Due to the feasibility study changes (footnoted earlier), the project depths for the NED 2-3 and NED 2-5 plans were modified from 72 ft to 71 ft for the Main Channel and from 66 ft to 67 ft in the South Channel. The changes occurred after the currents for these NED plans had been modeled. The depth change was not significant enough to warrant modifying and re-running the 3-D current model; therefore, the currents used in the simulator for these NED channels were calculated with the original project depths. However, the simulator channel geometry and the drafts of the NED design ships (BC, T3 and T4) were based on the revised channel depths of 74 ft and 70 ft, which include the specified +3-ft tidal advantage (see Table 2). The current model for the NED 2 channel was modified after the feasibility study changes because of significant modifications to horizontal dimensions.

## Wind

The two wind directions chosen for the simulator study, WSW and SE, are the predominant wind directions which cause critical current conditions at the entrance of Los Angeles Harbor. This was verified for the proposed harbor with wind sensitivity testing on the current numerical model. The 20-knot wind speed was used as the design wind because its frequency of occurrence is sufficient for it to be considered a normal critical condition. Wind data from the period 1984-1988 (Seabergh et al, 1994) indicate that winds of 20-30 knots occurred about 3.10% of the time during an average year. In contrast, the same data indicate that winds greater than 30 knots occurred approximately 0.02% of the time. Winds of magnitude 20-30 knots, on average, came from the southerly-southeasterly octant about 0.20% of the time of record and about 2.60% from the southwesterly-northwesterly quadrant. Despite its relative infrequency, the SE wind condition is important because of the approaching fronts of extratropical storms during the winter months and the exposed nature of the harbor to swell from this direction.

## Current vector plots

Plates 1-24 show vector plots of the current data used in the simulations of the existing and all proposed channels. These plates indicate little significant difference in current magnitude and direction between different proposed channel plans. The current magnitudes in the more protected areas of the proposed channels are essentially negligible, being on the order of 1/3 knot or less. By contrast, current velocity in the Angels Gate area reaches a maximum of less than 1 knot. It should be remembered that the currents used in the simulation study are depth-averaged values from a three-layer numerical model; had the surface currents been considered exclusively, magnitudes would have been significantly higher.

## Waves

The primary effect that waves have on vessels is what is known as "wave drift." This drift results from the kinematic action of water particles in real waves which is different from the particle motion associated with ideal sinusoidal waves. As a real wave propagates, a water particle actually undergoes a net displacement in the direction of propagation rather than moving in a circle and returning to its original position as in sinusoidal waves. When a ship is present, this action results in a tendency for a vessel to move laterally as waves pass by. It is this lateral movement, most pronounced with beam waves, which has the most significant consequence for the design of channel width. If the waves are large enough the pilot must continually counteract the drift in order to stay within the channel. Wave drift (or net horizontal movement) is accompanied by horizontal and vertical oscillatory motions which are characterized by movement about a mean ship position and have a less significant effect on the channel width requirements of a transiting vessel (except in

extreme conditions where capsizing or broaching may occur). For the scope of work in the Los Angeles study, in which channel width requirements were the main focus, net horizontal movement would be the most important part of wave/vessel interaction; consequently, wave drift was included in the hydrodynamic calculations. Vertical motion of vessels in the Angels Gate entrance was considered in an earlier study (Pizzariello and Hwang 1989) which concluded that 10% underkeel clearance is the minimum allowable for safety. Inside the entrance, the study found that less underkeel clearance would be acceptable.

Wave data from the Los Angeles offshore region (Platform Edith) indicate that incident swell (generally longer than 8 sec period) is predominately from the WSW and SE directions. It would be these long period waves which would affect the large design ships tested in the simulation study. Wave physical modeling for an earlier design of the Los Angeles Pier 400 development (Bottin and Tolliver 1989) included tests with incident waves propagating into the harbor from both a 231-deg and 154-deg direction. It was assumed for the simulation study that these directions were close enough to the WSW and SE wind directions, respectively, to approximate real conditions. Photographs of the physical model tests (Bottin and Tolliver 1989) show the crest pattern of the modeled waves during propagation through Angels Gate and into the proposed dredged channels. The report also tabulates wave heights in selected locations throughout the harbor area resulting from the propagation of incident waves<sup>1</sup>. Figures 7 & 8 show vectors representing the general wave pattern used in the simulation studies. These values were used for simulation tests in all proposed channel configurations. Wave characteristics along the simulator channels were obtained by linear interpolation between locations of known data.

---

<sup>1</sup> Results from Plan 1 in the referenced report were used.

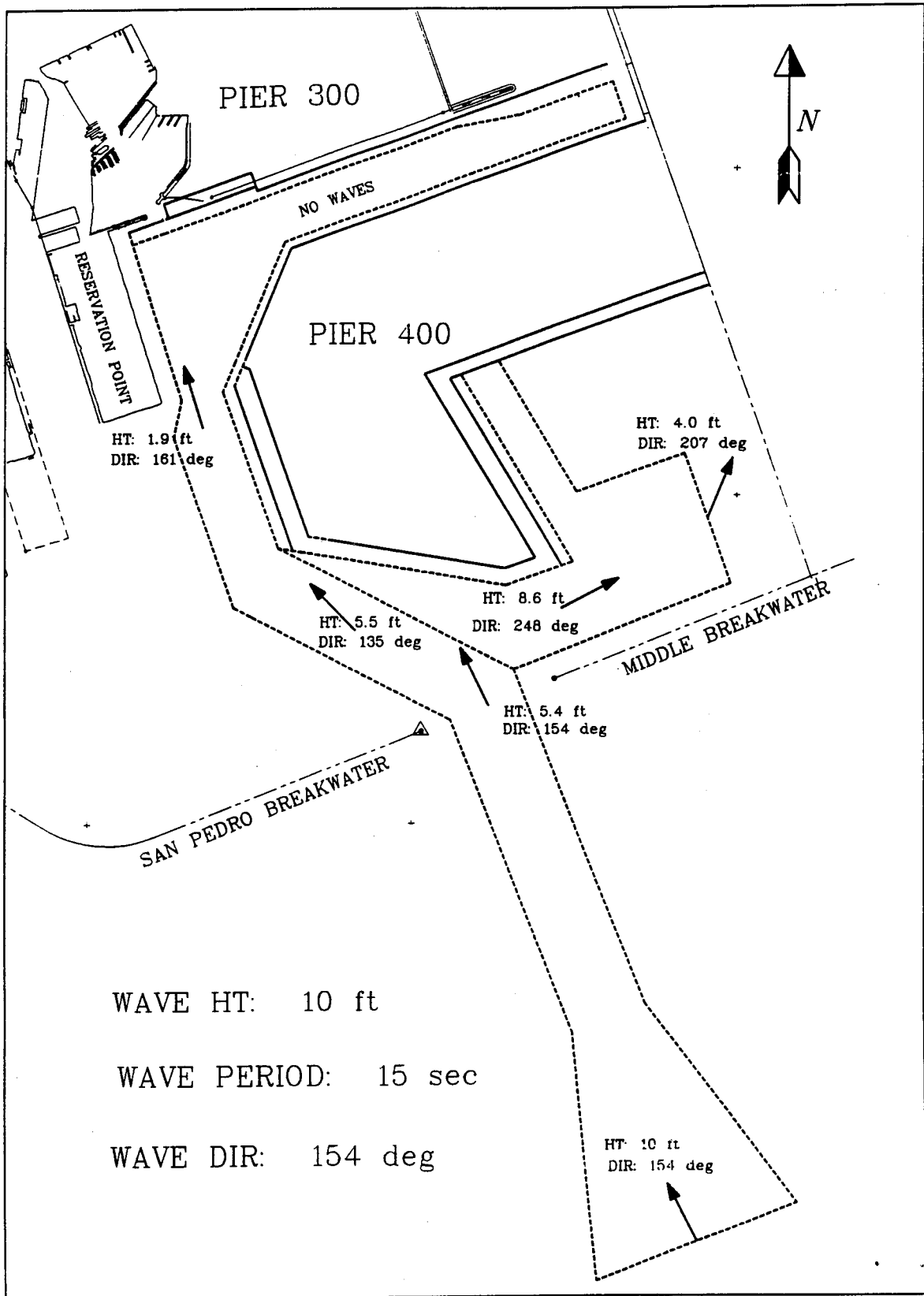

Figure 7. SE Wave conditions

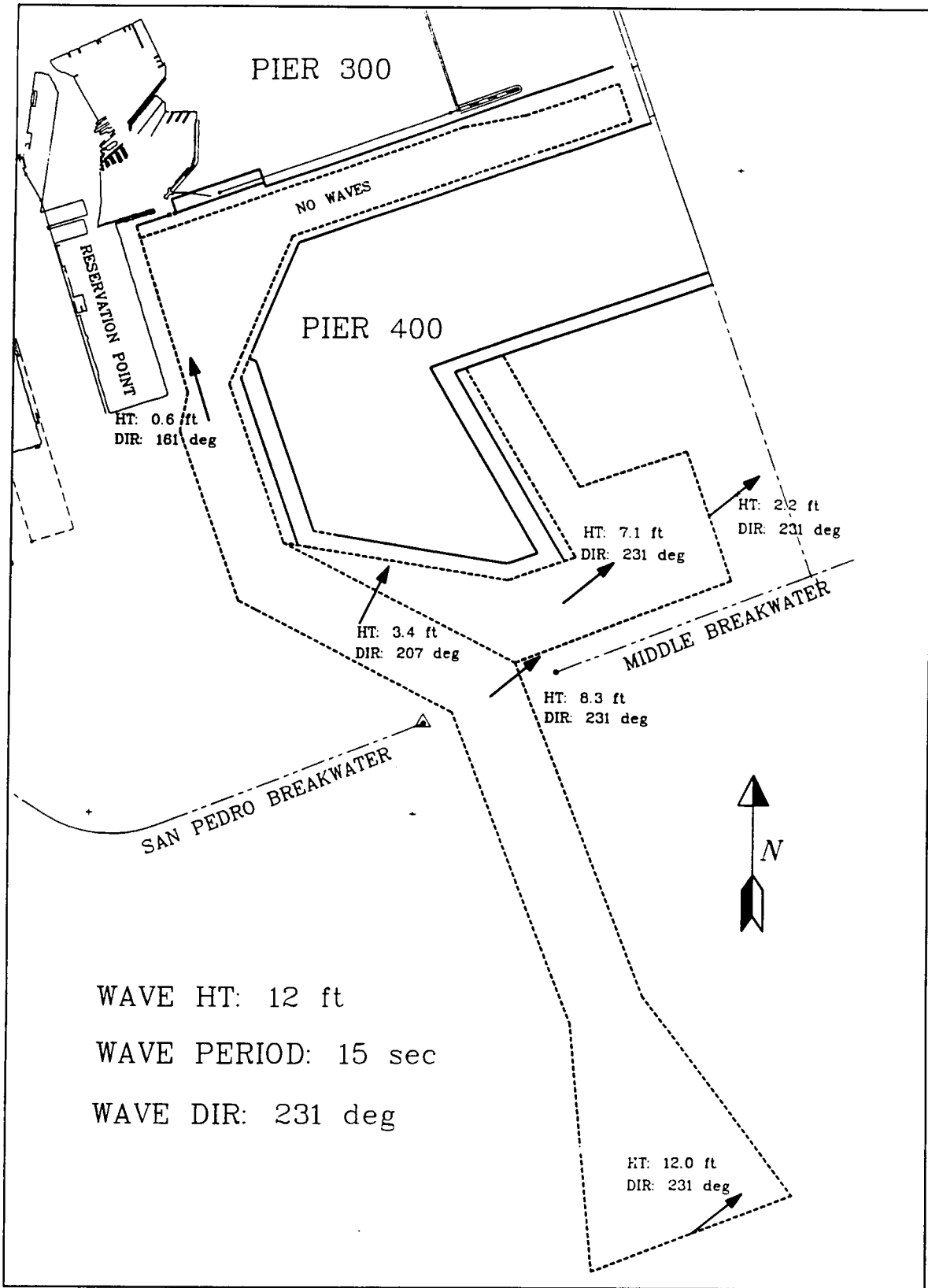

Figure 8. WSW wave conditions

## 3 Study Results

---

Plates 25 - 107 show composite trackplots of the simulation runs from the Los Angeles simulation study. Individual trackplots are shown on Plates 108 - 285. At the beginning of the plate section is a key which can be used to locate particular scenario trackplots. The simulation testing was organized into three phases: (a) phase 1 - two-way traffic with containerships in the POLA I, POLA II and NED 2-5 channels, (b) phase 2 - one-way traffic for tankers and bulk carriers in the POLA I and POLA II channels and (c) phase 3 - one-way traffic for tankers and bulk carriers in the NED 2 and NED 2-3 channels.

### Pilot Testing and Simulation Validation

The Los Angeles Harbor study was unusual in that completely new channels, port facilities and ships are proposed; therefore, validation of the simulation for the existing channel was of limited scope. At the beginning of phase 1 testing, the pilots were asked to judge the handling of the design ships and evaluate the current and wind conditions of the existing channel. These tests focused primarily on meeting/passing maneuvers between Post-Panamax containerships with which the pilots had handling experience. Because comparison with proposed channel simulations is not significant, results from the existing channel runs are not presented. The design tankers and bulk carriers, although different than those which the pilots have had experience handling, required some general validation through simulation runs. Validation of these ship numerical models was based on the pilot's basic knowledge of ship maneuvering. Another round of ship model validation runs was made at the beginning of phase 3 testing because of the NED feasibility design changes. Generally, the simulation models were acceptable and the validation exercises resulted in only minor changes to the simulation input data bases before actual testing began. During the study, a total of eight different professional pilots from the POLA visited MSI's Newport, Rhode Island simulator facility for testing. When it was not possible for two Los Angeles pilots to be on-site concurrently, two-way simulations were run with the aid of an experienced pilot on the MSI staff.

## Two-way Containership Tests (phase 1)

Trackplots for the two-way traffic simulations using the C10 containerships are shown on Plates 25 - 66 (composites) and 108 -189 (individual). It was determined through preliminary runs in the existing channel that the WSW wind and current condition was the most critical for these tests. The majority of the runs in phase 1 were tested in the WSW conditions; however, SE conditions were run for particular cases in phase 1 and are presented as well. The current pattern and magnitudes shown on Plates 1 - 24 do not indicate significant differences between the various proposed channels. This implies that conclusions and recommendations can be made in a general sense based on all the two-way tests regardless of specific test channel. In addition to the few full length runs completed, two-way traffic scenarios consisted of shorter runs in the following locations:

- a.* Angels Gate
- b.* Channel bend southwest of Pier 400
- c.* Western side of Pier 400
- d.* Constriction at Reservation Point
- e.* Containership slip between Piers 300 and 400

### Full length runs

Plates 108-116 show a few full length containership runs conducted during phase 1 testing. These runs were completed generally at the beginning of a pilot's visit to the simulator. The pilots were, therefore, unfamiliar with simulator operations and limitations and these runs were basically warm-up tests. As evidenced by the trackplots, the pilots paid little heed to channel limits and frequently vessel speed increased to an unrealistic level. Most of the areas where the vessels went outside the proposed channel in these runs have naturally sufficient water depth. These runs are not considered indicative of navigation problems in the proposed channels but only illustrative of a pilot learning curve which must be considered when interpreting simulation results. The first of these trackplots (Plate 108) shows the test during which the maximum passing ship effects were recorded on the moored tanker at Pier 400W. Although other full length runs show closer containership approaches to the tanker than Plate 108, this particular run recorded the highest speed in the area adjacent to Pier 400. In actuality, it was the outbound ship which caused the greatest interaction effect on the tanker. A more detailed discussion concerning passing ship effects is presented later in this report.

### **Angels gate**

Plates 25-33 and 117-135 show the two-way runs which focused on the breakwater entrance. Even though there is an evident northward drift for the inbound ships during the entrance turn, all the runs were completed without what would be considered a grounding. The 41-ft draft containerships are not restricted to the proposed design channel in this area, making the available channel wider than the proposed deep channel. The northward drift is especially pronounced for flood tide (Plates 26, 29 & 32) at which time wind, waves and tide all act in the same direction. Naturally deep water in the area keeps this drift from being of any great concern. In addition, it is important to point out that in the simulation the inbound ship approached the gate from within the entrance channel, forcing the sharp turn after the gate. In the actual channel, a containership could approach the gate from outside on a heading similar to that of the interior channel, thereby reducing the required degree of turn. This is possible due to deep water outside the design channel, relative to the ship's draft, seaward of the breakwater.

### **Channel bend**

Plates 34-42 and 136-150 show the trackplots of the meeting/passing runs in the channel bend southwest of Pier 400. In a few of the simulator runs the inbound ship came within a ship-beam of the moored ship. Again, it is important to note that the 41-ft draft containerships are not restricted to the marked deep channels tested. Once the outbound containership is opposite Pier 400 and enters the juncture of the existing Main Channel and the proposed channel, useable water area expands greatly. With the outbound containership transiting farther to the west, it would not be necessary for the inbound vessel to crowd the moored Pier 400-tanker to such an extent evident in the simulations. This would greatly alleviate possible problems stemming from a ship passing too close to a docked vessel at Pier 400. Providing an expanded -45-ft (mllw) channel in the area outside the western edge of the deep channel, opposite Pier 400 and south of Reservation Point, would allow the pilots to follow this strategy. Most of this area is comprised of the existing channel and the depth is sufficient for containerships. This suggestion is largely based on discussions with pilots and engineers from the Los Angeles area who are experienced and knowledgeable concerning vessel traffic matters and who were also involved with the simulation study. Later in the report, an analysis concerning the passing ship effects recorded during these runs is presented.

### **Pier 400**

Plates 43-51 and 151-162 show the simulation results from the two-way traffic tests alongside Pier 400. These results are similar to the ones for the previous channel bend discussion; although, in a general sense the runs were more successful.

### **Constriction point**

This area was the most critical location tested for meeting/passing maneuvers. As indicated on Plates 52-60 and 163-180 there were few successful runs. In the majority of the runs one or both of the meeting ships ran out of the marked channel. There were a number of factors which affected the pilots' ability to meet another ship at this point. First is that both ships were completing turns prior to the constriction. A second factor is that the pilot on the inbound containership was trying to slow down in preparation for docking and was also trying to gradually transfer control to the attendant tugboats. Also, the inbound ship was passing a docked ship at Pier 400 requiring reduced own-power and speed approaching the constriction. The combination of these factors put a high level of workload demand on the pilots in this area and the added distraction of meeting another ship created unsafe circumstances. The proposed configuration of the constriction at Reservation Point is, effectively, a short, sharp bend. In the POLA I channel, widening on the eastern side of the constriction may alleviate the problem and allow two containerships to pass each other safely. A specific recommendation is presented later in this report. Any widening in the POLA I channel in an attempt to alleviate the constriction would require additional simulation tests to determine the effectiveness of the extra width. The present study indicates that widening without straightening in the constricted area would not be optimally effective because it would not eliminate the channel bend. The only definitive way of allowing two-way traffic through this area is to straighten the channel. Recommendations for bend straightening in the POLA II channel are presented later. Without modifications in the area, operational restrictions on two-way traffic must be employed.

Plates 171 & 172 for the POLA II channel show runs which experimented with operational alternatives to meeting and passing in the 650-ft constriction. In these runs the outbound ships "held up" in the proposed turning basin while the inbound ship slipped through the constriction. Plate 171 shows that the outbound vessel drifted outside the channel along Reservation Point while waiting for the inbound vessel to clear the area. This problem was the result of the outbound vessel starting position being too close to the constriction. In the next run, Plate 172, the outbound vessel started from within the containership slip between Piers 300 and 400. The inbound vessel then was able to move through the narrow section and complete a 360-degree turn in the turning basin after the outbound vessel passed. The results indicate that there is adequate maneuvering room in the turning basin for various ship-meeting strategies. Specific maneuvers would be handled on a case by case basis and would require coordination between ship pilots to avoid meeting at the constriction.

### **Containership slip**

Plates 61-66 and 181-189 show the two-way simulator runs conducted in the section of the channel between the container yards of Piers 300 and 400.

These tests included an outbound ship leaving its berth and an inbound ship backing into the channel section from the new turning basin. The operational limitations of the simulator facility affected these scenarios significantly. In backing maneuvers the awkwardness of switching viewing angles and the difficulty of determining distances on the simulator visual scene caused problems for the pilots. It was concluded, through discussions with the pilots, that the maneuvers were much harder on the simulator, because of visual problems, than they actually would be. The study indicates that there is enough room for two ships to pass each other in the area with tug-assist, even with docked ships on either side of the channel. There were enough successful simulator runs to indicate this. The pilots will gradually become accustomed to the new configuration and, through their expertise, adopt practices which will make ship transit safe in this area.

### **Pilot questionnaire results**

After each simulator run each pilot was asked to fill out a questionnaire for the purpose of gauging the relative difficulty of the maneuver. A copy of the questionnaire is shown in Appendix B. Each question was not applicable to every run. Questionnaire results should always be viewed in a general way, because sample sizes are normally not large enough to deduce statistical significance. A survey of pilot responses for the two-way traffic scenarios indicated no difference between average ratings for either the different channel plans or different environmental test conditions. The three pilots who participated in the phase 1 testing, on average, rated scenario difficulty as 5.0 for all applicable questions. This indicates that the test conditions in the different proposed channels did not vary appreciably.

### **Passing ship effects**

During the two-way tests, ship-ship interaction forces (lateral and longitudinal) and moments were recorded for both piloted vessels and vessels docked in the specified berthing areas as shown on the trackplots. The numerical method for calculation of ship interaction effects (Ankudinov 1988) was validated and tuned for the Los Angeles project during initial testing on the simulator.

Observance of meeting/passing maneuvers during simulations for the two containerships indicated that a minimal amount of interaction between the two piloted vessels can be expected in the proposed channels. This was evident in the tests primarily because of the proposed wide channels and fairly large underkeel clearances which resulted in the pilots experiencing few control problems while meeting other ships. Vessel control during simulated meeting/passing was not a problem for most channel locations with the exception of the 650-ft constriction already discussed. In this area the maneuvering problems were more a result of geometry than hydrodynamic interaction between vessels, because the ships were moving at fairly low speeds.

The object of the present discussion is the passing ship effects on the docked vessels. Prior to the simulation study there were concerns about whether or not ships transiting the proposed channels would cause mooring lines on berthed vessels to break. Phase 1 testing included simulations where 41-ft draft containerships passed 325K DWT tankers moored at Pier 400. The draft of the moored tanker was dependent on channel plan and is noted on individual trackplots. During the simulations the moored ship was unmovable; therefore, the recorded effects represent the forces and moments acting upon a ship assumed to be rigidly held by its mooring system. A survey of individual runs from phase 1 testing showed that the maximum lateral force recorded on the moored ship, during any run, was about 55 tons and the maximum moment during the same run was 45,000 ft-tons. Figure 9 shows the forces and moment recorded during this particular run. It is important to note that the passing vessel in this particular run was traveling at about 6.5 knots and moved past the docked ship on a fairly close approach of about 300 ft between hulls. These fairly severe conditions are unlikely and are circumstances which professional pilots will avoid.

Taking a simplified static approach, the lateral force and the force derivable from the moment can be added to obtain an estimate of the total lateral force. It is assumed, in order to establish a large safety margin, that the maximum lateral force and moment occur simultaneously (not analytically correct) and that a force at the stern (or bow) creates the moment about the center-of-gravity of the ship. With these assumptions, the active moment arm is half the ship's length (605 ft). Dividing the moment by the moment arm results in a force of 74 tons acting at either the bow or stern. This gives a total lateral force of 129 tons which must be resisted by the mooring system. Longitudinal forces did not attain such high magnitudes.

Strength data for various mooring line materials (Bruun 1989) indicate that the breaking strength of 2-inch diameter steel cable ranges between 90 tons and 150 tons depending on material grade. Therefore, a maximum of two steel lines of this diameter would be required to resist the recorded force of 129 tons, assuming equivalent pretensioning. At most times ships of this size will have 10-14 individual lines attached for mooring. About four of these lines will be spring lines set up for longitudinal resistance only and the remainder (6-10) will be available for lateral resistance. It has to be assumed that half of the remaining lines would be unloaded because of rotation about the ship's center-of-gravity. This leaves approximately 3-5 lines to resist the calculated static load of 129 tons. The precise mooring line arrangement and material to be used is unknown; however, these test results show that passing containerships should not cause line breakage under normal circumstances where the mooring system is well managed, i.e., where lines are not allowed to become slack. As lines slacken, the movement of the moored vessel increases and, therefore, so do the dynamic loadings on the lines. The static assumptions of the present analysis do not account for dynamic effects and precise line tensions cannot be obtained with this approach. Numerical modeling of mooring system dynamics is required for a complete analysis, but

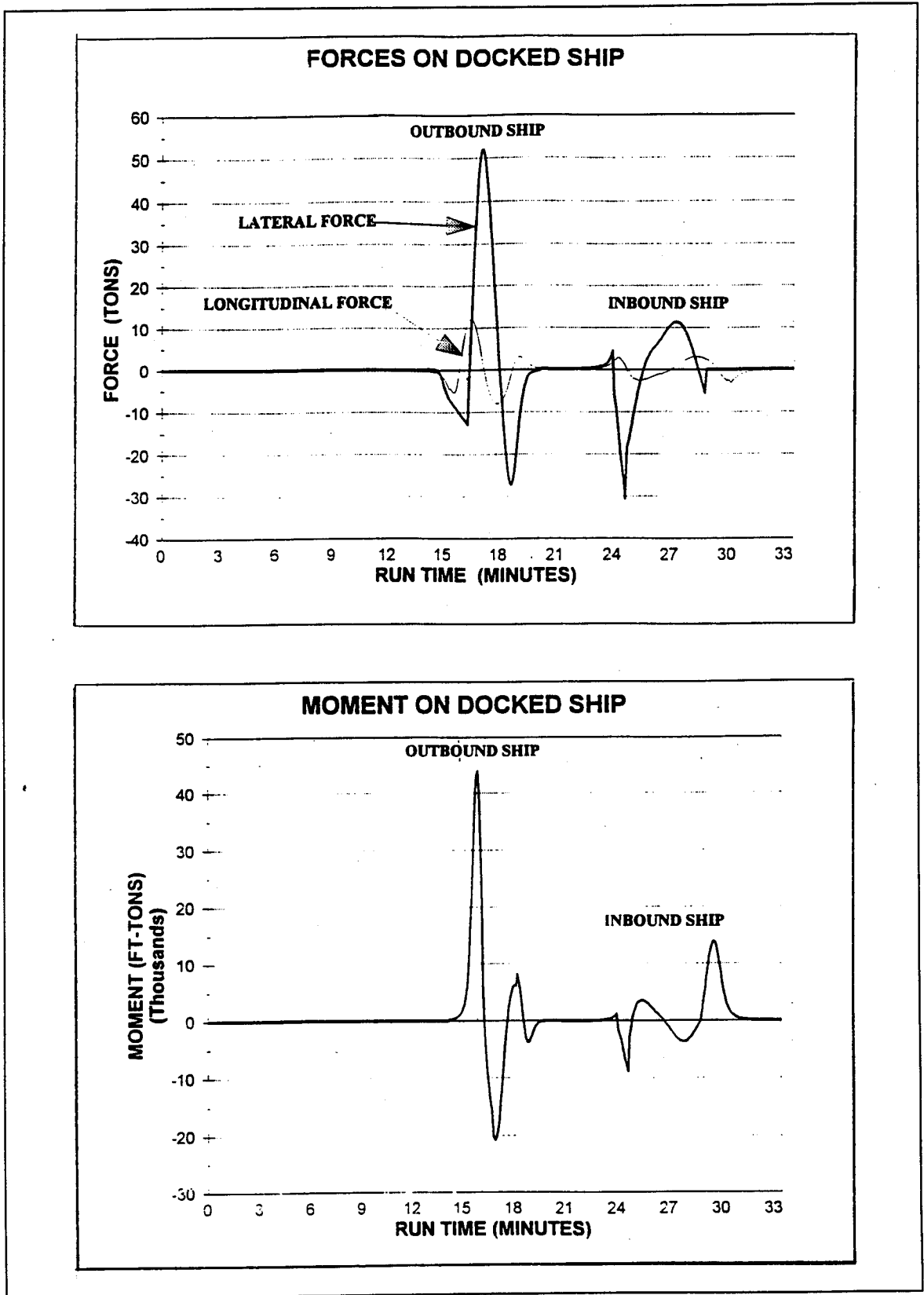

Figure 9. Passing ship effects

is beyond the scope of the present study. Time series data of the passing ship effects can be provided if requested.

## **One-way POLA Tests (phase 2)**

These tests were comprised of five basic scenarios as shown on Table 2. The primary focus of the tests was to check the safety of the POLA I and POLA II channels for the deep-loaded tankers and bulk carriers. Plates 67-83 show the composite trackplots for this phase of simulation testing and Plates 190-232 show the individual results. Although many different conditions were tested, it became evident, through simulation observation and subsequent data analysis, that handling of the design ships in the proposed channels was not particularly sensitive to the variation of wind, waves and tides. By far the most critical factors were simple geometry and inertia of the very large ships.

### **Pier 300/coal dock**

Plates 68 and 195-197 show outbound results for the POLA I simulations associated with the coal dock. Plates 81-83 and 226-232 are trackplots showing outbound runs in the POLA II channel. The coal dock is a commercial facility which will have bulk carriers up to 250K DWT. The 265K DWT vessels in the simulations were used because they were very close to dimensional equivalency with the 250K bulkers. None of the outbound runs show the pilots having significant difficulty leaving the dock and proceeding toward the entrance.

Being an exporting facility, the coal dock will have ships arriving in ballast and leaving loaded; therefore, inbound ships had drafts of 44.5 ft in the simulations. Plates 69-70 and 198-203 show the inbound trackplots of the ships being positioned to dock at the coal dock in the POLA I channel. No inbound runs were tested in the POLA II channel. Plate 200 shows one run in which the pilot had some difficulty staying in the channel opposite Pier 400. This probably resulted from the pilot's starting to turn too late. Plate 70 indicates that turning maneuvers (mostly counter-clockwise) took up much of the turning basin with some of the vessels crossing the channel limit on the southeast face of the basin (see individual trackplots). Both of these problems are thought to be attributable to the pilots' difficulty in determining ship position on the simulator and are not considered indicative of vessel control problems. One pilot (Plate 201) made a clockwise turn in the basin, instead of the more frequent counter-clockwise direction. This trackplot indicates that although this type of turn requires a full 360-degree swing it is an acceptable alternative strategy and may even be easier, as most ships turn clockwise more efficiently. The results indicate that there is no significant problem with maneuvering the large bulk carriers through the 650-ft constriction at Reservation Point and into position for docking at Pier 300. The primary objective for a successful turn is positioning the ship in the center of the basin, which will be much easier in the real channel than on the simulator.

## Pier 400 West

Pier 400 along the Main Channel will have one berth for a 325K DWT tanker in the POLA I channel and two berths for the same size ship in POLA II. In the POLA I simulator scenarios the inbound tanker proceeded past the pier, turned around in the new 1800-ft diameter turning basin and headed down the channel to a port-side-to docking position at Pier 400. In the POLA II channel the same scenario took place with the added feature of the ship passing another 325K tanker already docked at one of the berths at the pier.

Plates 67 and 190-194 show the inbound simulation results for the POLA I channel. In one of the runs (Plate 193) the vessel drifted outside the channel just inside the breakwater. This was the result of poor judgement in the entrance channel outside of the breakwater where the pilot allowed the vessel to drift too far to the west making the Angels Gate bend difficult to maneuver. All the turns in the basin were clockwise and were accomplished with adequate room to spare, despite a couple of runs in which the ship was stopped and turned short of the center of the basin. This problem was related to the difficulty the pilots had in judging distances on the simulation visual scene. Pier 300, which was directly ahead of the ships, appeared much closer in the simulation than it actually would, making the pilots think they were running out of basin. Taken as a group these inbound runs were highly successful and indicate no significant safety problem with the basic design of the channel.

Plates 75-77 and 212-217 show results for the inbound runs to Pier 400 (west) in the POLA II channel. Only in the run on Plate 212 was there any difficulty. The vessel, once again, drifted outside the deep channel because of turning too late. This could indicate a problem because the test ship in this case was deeply loaded; however, with improved visual cues, as available in the real world, the pilots would be able to judge ship position more accurately and make better judgements on when to start turns.

Discussions were held throughout the simulation tests concerning the operational procedures the pilots might follow when bringing vessels to Pier 400. Prior to the simulation tests it was understood that there would be specific safety regulations required by the Port of Los Angeles stating that ships would be docked bow-out. In other words, ships would always have their bows pointed in the outbound direction in order to facilitate leaving in an emergency such as a dockside fire. This requirement would mean that the large petroleum tankers calling at Pier 400 would have to be turned while loaded. This was the scenario tested in the simulations. During the course of the tests the pilots said that it would make more sense for the loaded tankers to pull straight in to Pier 400 starboard-side-to and then proceed, in a light condition, to the turning basin after unloading their cargo. It is unclear as to which procedure will be used. However, the scenario tested in the simulations (turning loaded) was the most critical of the two and thus should suffice as a safety test. The results show that the turning basin is adequately sized for turning the 325K tankers. The only problem which became apparent in the tests was

that frequently the pilots did not pull far enough north before stopping and ended up turning around in the southern portion of the basin without enough maneuvering room. The reasons for this have already been discussed.

### **Pier 400 East**

Inbound transits for the POLA II South Basin channel are shown on Plates 71-74 and 204-211. This is the area which is also known as NED Increment 3, South Channel. The 265K tanker loaded to a draft of 68 ft was the design ship for these scenarios (T2). Of all the one-way tests in the study, these scenarios were the most difficult. For the inbound case, vessels were required to stop just inside the breakwater and make a right turn before proceeding into the turning basin. The stop occurred in the most exposed location in the harbor with the worst wave, current and wind conditions. In the simulations the pilots on inbound runs were asked to refrain from using tugs while making the 90-degree right turn into the South Basin. Tug usage was then allowed once the turn had been made and the ship was safely behind the breakwater. Plate 210 shows one run in which the pilot experienced some difficulty making the 90-degree turn in the entrance. In this run the vessel approached the south face of Pier 400 too closely before completing the turn. The trackplot also shows the vessel leaving the channel edge outside the entrance. These two problems suggest that the pilot in this particular simulation had difficulty with perception of ship location in the channel. All the other runs show that the turn is manageable in the conditions tested. Even on Plate 205 this is evident because close examination reveals that the pilot completed the entrance turn successfully and only had problems subsequently.

One of the pilots commented that making the turn without tug assist was unrealistic because in actuality he could not be assured that the ship's engine would respond to the full astern and full ahead orders ("full bells") given fairly frequently. At times, in actual practice, the water will be too rough to allow tugboats to come in hull contact with arriving tankers. This problem can be alleviated by the use of line guns which are aboard some of the tugs presently operating in Los Angeles. This equipment allows lines to be "shot" aboard tankers, making it possible to have tug control without contact between vessels. The simulation results show that with vessel equipment in good working condition the channel configuration tested is safe; however, there will be some weather conditions and operational circumstances which will require extra caution and pilot judgement. One design modification which would make the turn easier is to cut back the eastern corner of the channel near the breakwater. The extra room on the inside of the bend might allow the pilots the ability to turn into the south channel without coming to a complete stop in the exposed entrance area.

The proposed docking area along the eastern side of Pier 400 includes two berthing areas for 265K DWT tankers. In the simulation tests one of these tankers was docked in the southernmost berth. After the 90-degree turn in the entrance, the inbound tanker was required to make a partial turn in the South

Basin and back past the docked tanker into the northernmost berth. This maneuver created difficulty for some of the pilots, most easily illustrated by the run on Plate 205. In this run it is evident the pilot misjudged the distance required to stop the ship and turned far short of the basin, actually colliding with the docked tanker. In the real channel, with adequate channel markers, misjudgment of vessel position will be easily avoided. In the remainder of the runs the turn in the basin was successful, but it is clear that a vessel with tugs alongside would not have enough room to maneuver between the docked vessel and the opposite corner of the 600-ft wide channel (Southern Slip) where it opens into the turning basin. Details of a recommendation to widen the entrance to Southern Slip are presented later in this report.

Pier 400 will generally be an importing facility and thus the ships will arrive loaded and depart empty. Plates 78-80 and 218-225 show the outbound simulations for the POLA II channel in which a ballasted tanker started from a docked position in the northern berth of Pier 400E. The outbound runs were easier for the pilots to complete successfully when compared to the previously discussed inbound runs; however, it is still evident that there is inadequate room at the entrance to the turning basin from the Southern Slip. Also, cutting back the eastern corner of the channel near the breakwater at Angels Gate would improve the ability of the pilots to complete the sharp turn into the entrance channel. This modification would allow the pilots to start the turn earlier and steady-up outbound, on the entrance range, without inertial drift carrying the ship too close to the western channel edge. Although still important to consider, the use of tugs in the outbound case is somewhat less crucial because the pilots are not trying to stop the ship and, therefore, can control the vessels themselves more effectively.

### **Pilot questionnaire results**

The pilot questionnaire ratings from phase 2 testing showed slight differences in perceived difficulty between scenarios. The most difficult scenario during this phase was the inbound 265K tanker making the right turn into South Basin. The average rating recorded for this scenario for all eight rating questions was 6.2. The other scenarios ranged down to 5.0. There was general agreement between these difficulty ratings and general conclusions derived from simulation observations.

### **Passing ship effects**

During phase 2, passing ship effects were, again, recorded for most of the simulations. The runs involved piloted ships moving past docked vessels at Pier 400 on both the east and west side. The most significant difference between these tests and the earlier two-way simulations (with containerships) was the larger and deeper draft test vessels. These vessels were much more massive and blocked a larger percentage of the channel; however, they also were able to transit farther away from the docked ship because of the one-way

traffic restriction and, because of their size, the pilots slowed them down sooner in anticipation of stopping. After a survey of the data from phase 2 simulations it was determined that in none of the runs did the magnitude of forces and moments approach the level recorded in phase 1 tests. Typical interaction lateral forces were less than 20 tons and the moments were less than 5000 ft-tons. The survey revealed that in most cases the piloted vessels passed the docked ships with speeds of 4 knots or less. For the south channel inbound runs the piloted vessel actually passed the ship docked at Pier 400E while backing at a very low speed.

### **NED One-way Tests (phase 3)**

The earlier discussion on the POLA channels centered on recommendations concerning safety issues. The next sections will concentrate on both safety and efficiency of the proposed NED channel designs. The primary purpose of the analysis is to define the federal channel. Table 2 shows the three scenarios tested during phase 3.

#### **NED 2**

The purpose of the NED 2 plan is to provide access to coal loading facility at the western end of Pier 300. Plates 84-88 and 233-243 show the trackplots for the 250K DWT bulk carrier (BC) outbound from the coal dock. Tests for inbound bulk carriers were not conducted. Only the run on Plate 233 indicates any maneuvering problems pulling away from the dock. In this run it appears that the pilot started to drive forward too fast and almost ran out of the channel to the west. All the other of these runs indicate that the departure can be accomplished easily with use of tugboats. However, some of the runs show that the pilots had problems maneuvering through the narrow section of the channel adjacent to Pier 400. The restricted width (561 ft) created a situation in which the pilots could not turn their vessels early enough in the bend southwest of Pier 400 because their sterns would not clear the western channel edge. This resulted in the ships drifting close to the southern channel edge after the turn and cutting the corner in the entrance bend. These runs suggest that widening is needed in the channel segment along Pier 400 and navigation conditions in the entrance bend would improve with an inside cutoff.

Plates 89-92 and 244-251 show the inbound ship tracks for 325K DWT tankers (T3) going to the liquid bulk terminal along the western side of Pier 400. This berth is not part of the NED 2 plan; however, the inbound tanker trackplots, although associated with a ship larger than the coal dock design ship, provide an approximate indication of difficulties which may be experienced by inbound vessels. On many of these runs the vessel closely approached or went beyond the northern edge of the channel after entering the turn at Angels Gate. Widening along this side would alleviate the problem;

however, in this kind of situation, where the pilots are in the process of slowing down, a cut-off on the inside of the bend may be equally advantageous. This would allow the pilots to start the turn (inbound or outbound) earlier, keeping them from drifting too far to the outside of the bend. These particular runs indicate that the suggested channel improvements in the previous paragraph will provide adequate room for navigation of the 250K bulk carriers in both directions.

### **NED 2-3**

Plates 93-107 and 252-285<sup>1</sup> show trackplots for 325K DWT and 265K DWT tankers from the simulations for the NED 2-3 channel. The last two entries in Table 2 list the conditions tested. The 325K tanker was the most important vessel tested for checking the size of the proposed northern turning basin. Tests with bulk carriers were not carried out in NED 2-3, primarily because earlier tests covered these conditions fairly thoroughly for both inbound and outbound scenarios and the larger 325K tanker is the design ship for the plan.

Plates 93-97 and 252-263 shows the inbound runs for the 325K tanker going to Pier 400W. Although there was a different emphasis in these NED tests than in the POLA tests, many of the same comments apply here (see phase 2 trackplots and discussion). All runs were conducted with the pilots bringing the ship into the turning basin, turning around with tugs and ending the run with the vessel in a good position to be docked port-side-to at Pier 400. Even though many of the individual trackplots show the pilots had some difficulty in muscling the tanker around the channel bend southwest of Pier 400 (with tug assist), it is thought that this is unavoidable to some degree and is a result of poorly timed turns in the entrance bend. Maneuvering strategy in the area should improve after the pilots have actual experience with turning the very large ships in Angels Gate. In the turning basin, some of the pilots, again, stopped short of the center of the turning basin due to the misinterpretation of distances on the simulator; however, there was no indication of vessel control problems. Based on the simulation results there are no major design changes needed in this part of the channel. There is not sufficient evidence for justification of any channel narrowing. One minor modification (detailed in the recommendations section) involves the northwestern corner of the turning basin which, basically, will be unusable for turning operations. An additional inside cut-off at Angels Gate as discussed for NED 2 is not suggested here because the entrance channel is nearly 200 ft wider in the NED 2-3 configuration. The wider channel allows pilots more maneuvering room for the approach to, and preparation for, Angels Gate.

Plates 98-102 and 264-274 show the simulation results from the tests for the tanker inbound to South Basin in the NED 2-3 channel. The discussion concerning this area for the POLA II channel is also applicable here. The

---

<sup>1</sup> Plates show Pier 400 as proposed in NED 2-5 channel.

majority of the runs included successful 90-degree turns at the breakwater. Plates 272-274 show runs during which the tankers approached the south face of Pier 400 too closely. At least one of the phase 3 pilots was concerned with possible dangers of this maneuver. His statements were related to not having enough available tug power in the simulation. As stated earlier, it is evident that there will be certain weather-related operational restrictions contingent upon this maneuver. The problem can be alleviated by cutting off the corner on the eastern side of the channel at Angels Gate.

From the same plates it is evident that the entire area of the proposed South Basin was not used by the pilots during their maneuver into the Pier 400 berth. The inbound ships had to go through a turn less than 90 degrees before backing into the slip. As in the phase 2 simulations, the pilots had the same problem after completing the turn of not having enough maneuvering space in the 600-ft wide Southern Slip. These results show that similar widening is needed in the NED 2-3 channel as discussed in connection with the POLA II channel. The conclusion is that the full 2150-ft diameter of the South Basin is not needed for the required turning maneuvers because a full 360-degree turn is not made.

Plates 103-107 and 275-285 show the outbound tanker runs from the South Channel. Although a few of the pilots made a 90-degree turn in the turning basin (Plates 282, 284 & 285) most completed the simulations with turns closer to 45 degrees. Again, in these runs only a portion of the 2150-ft turning basin was used for maneuvering. A reduction in the size of the basin would not have a significant effect on the safety and efficiency of the channel.

#### **Pilot questionnaire results**

Again, the pilots filled out questionnaires after each run during phase 3. The results once again confirmed that the scenario with the 265K tanker heading into South Basin was the most difficult with a rating of 5.4. This was a consistent result throughout the study. The difficulty ratings for the other scenarios ranged down to 4.7.

#### **Passing ship effects**

Just as in the phase 2 tests, forces and moments on the docked vessels were recorded in phase 3 simulations. A data survey of these latest tests show very similar results to those from phase 2. The ship/ship interaction on the moored vessels present in the simulations for phases 2 & 3 reflected the much lower speed practiced by the pilots when conning the larger vessels.

## 4 Conclusions and Recommendations

---

Figures 10 - 18 show the recommended design modifications from the preceding discussions. Recommendations for each design channel are presented individually. The locations for the aids to navigation shown on the figures are intended to be approximate.

### POLA I

#### Study conclusions

- a. Two-way containership traffic is safe throughout the channel except in the vicinity of the proposed constriction at Reservation Point. With no design modifications, operational restrictions will be required on two-way traffic in this area.
- b. One-way traffic for the design tankers and bulk carriers is safe throughout the channel.
- c. The pilots should be able to pass any vessel docked at one of the proposed berths without causing damage to the mooring system.

#### Design recommendations

- a. Widen or straighten the constriction at Reservation Point for allowance of two-way containership traffic. Three alternatives are presented, Figures 10 - 12.
- b. Additional simulation tests for recommendation 1 (Fig. 10) if chosen. The precise impact of this recommendation on two-way traffic is unknown.

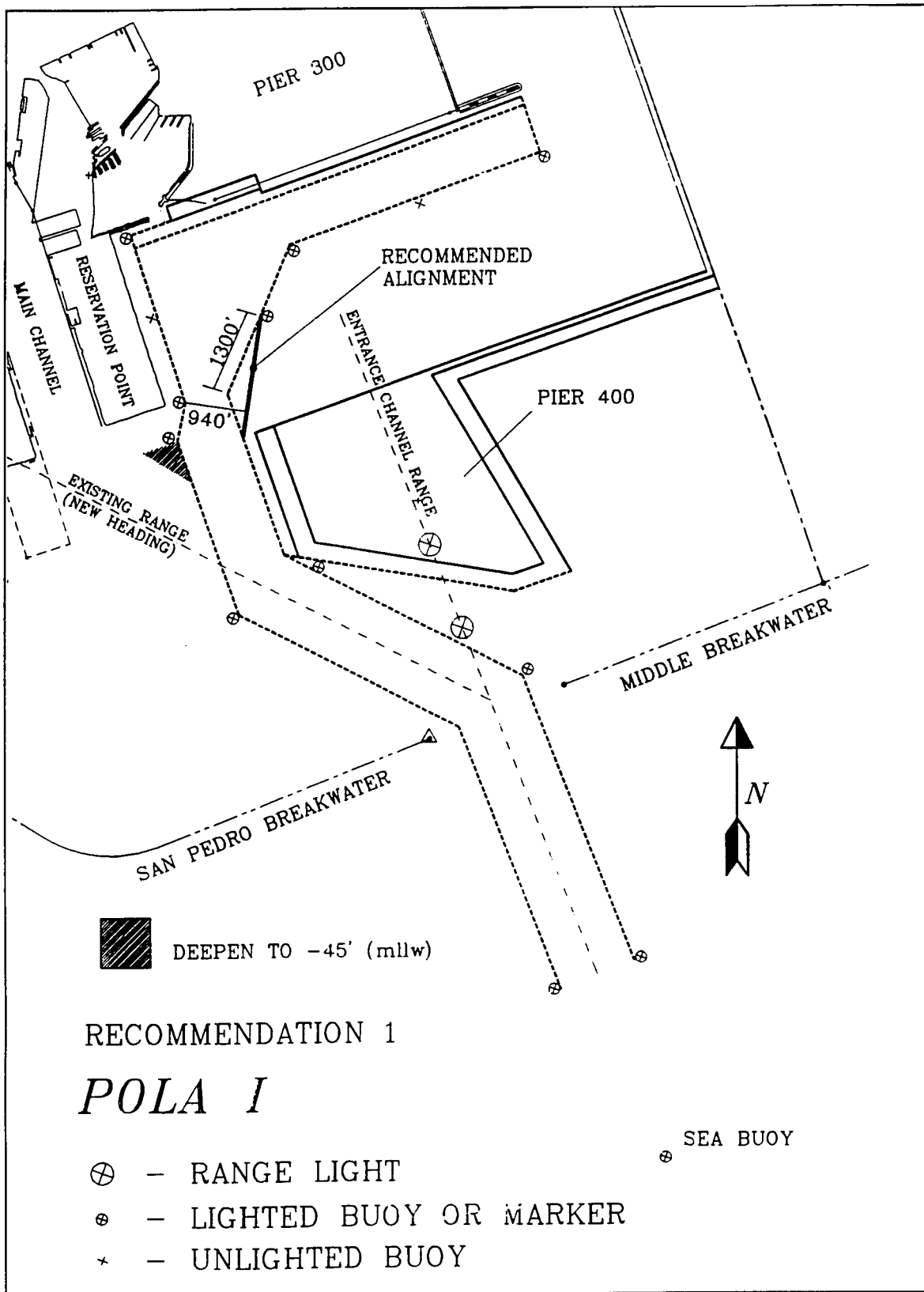

Figure 10. POLA I Recommendation 1

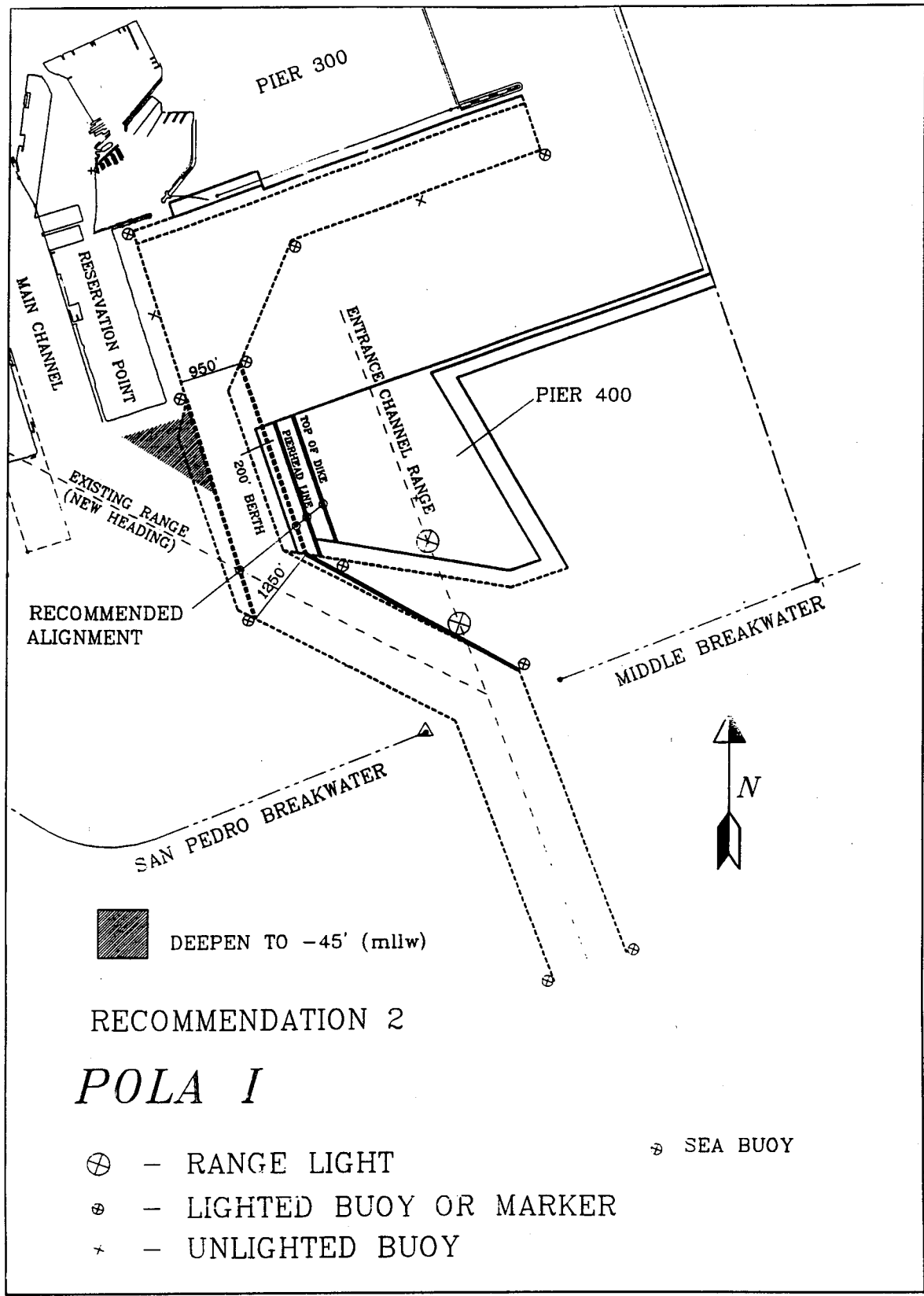

Figure 11. POLA I Recommendation 2

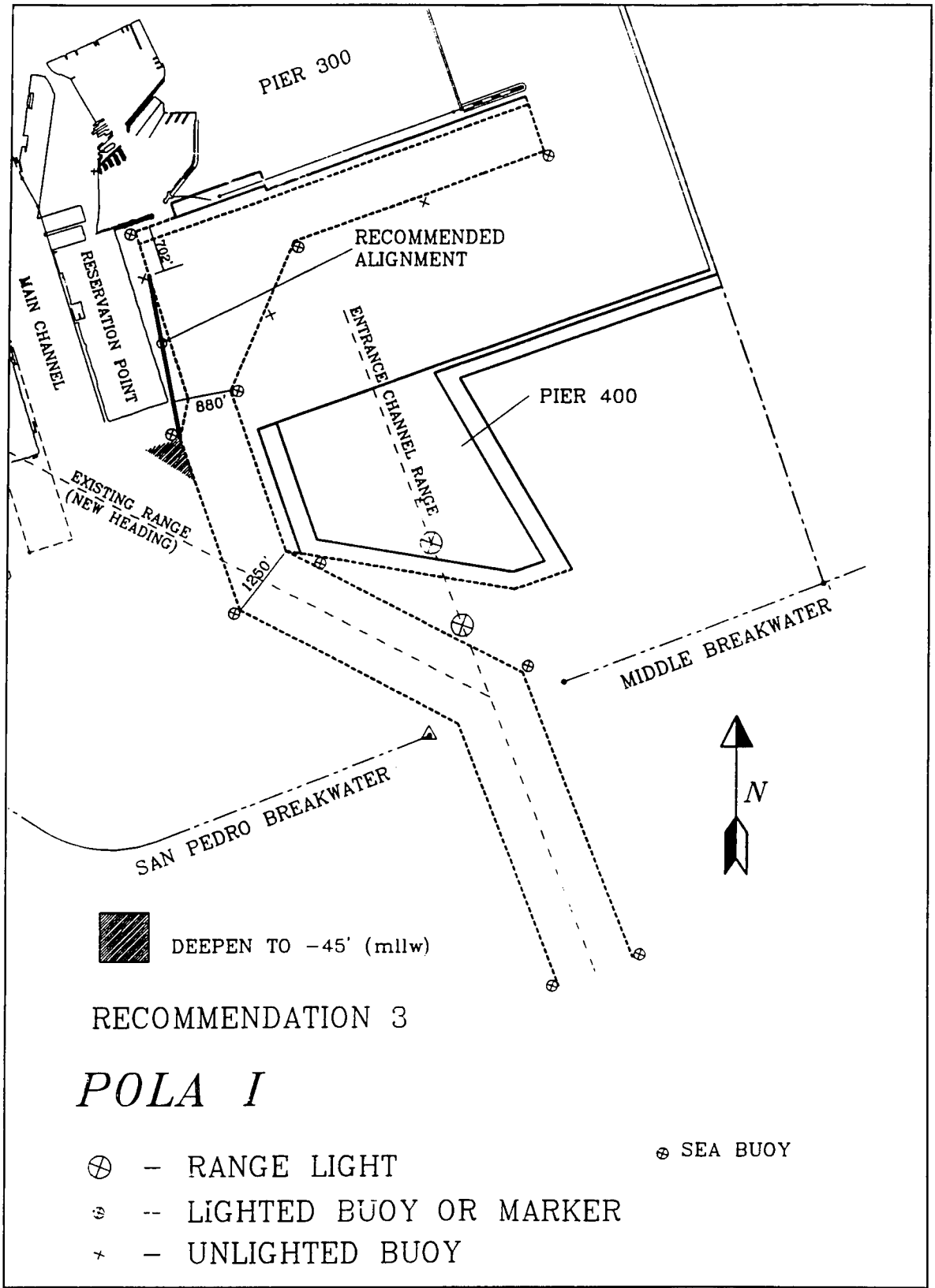

Figure 12. POLA I Recommendation 3

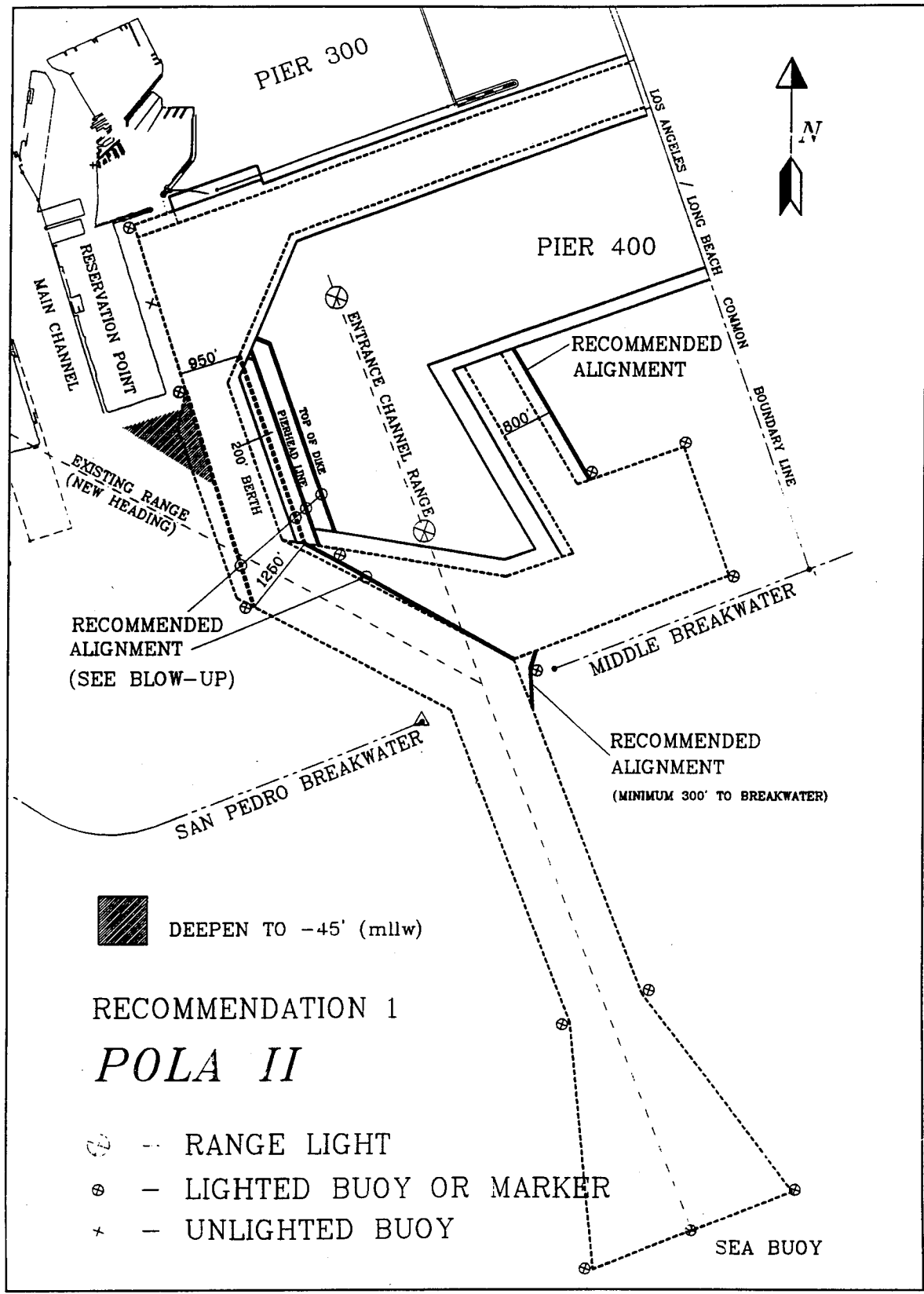

Figure 13a. POLA II Recommendation 1

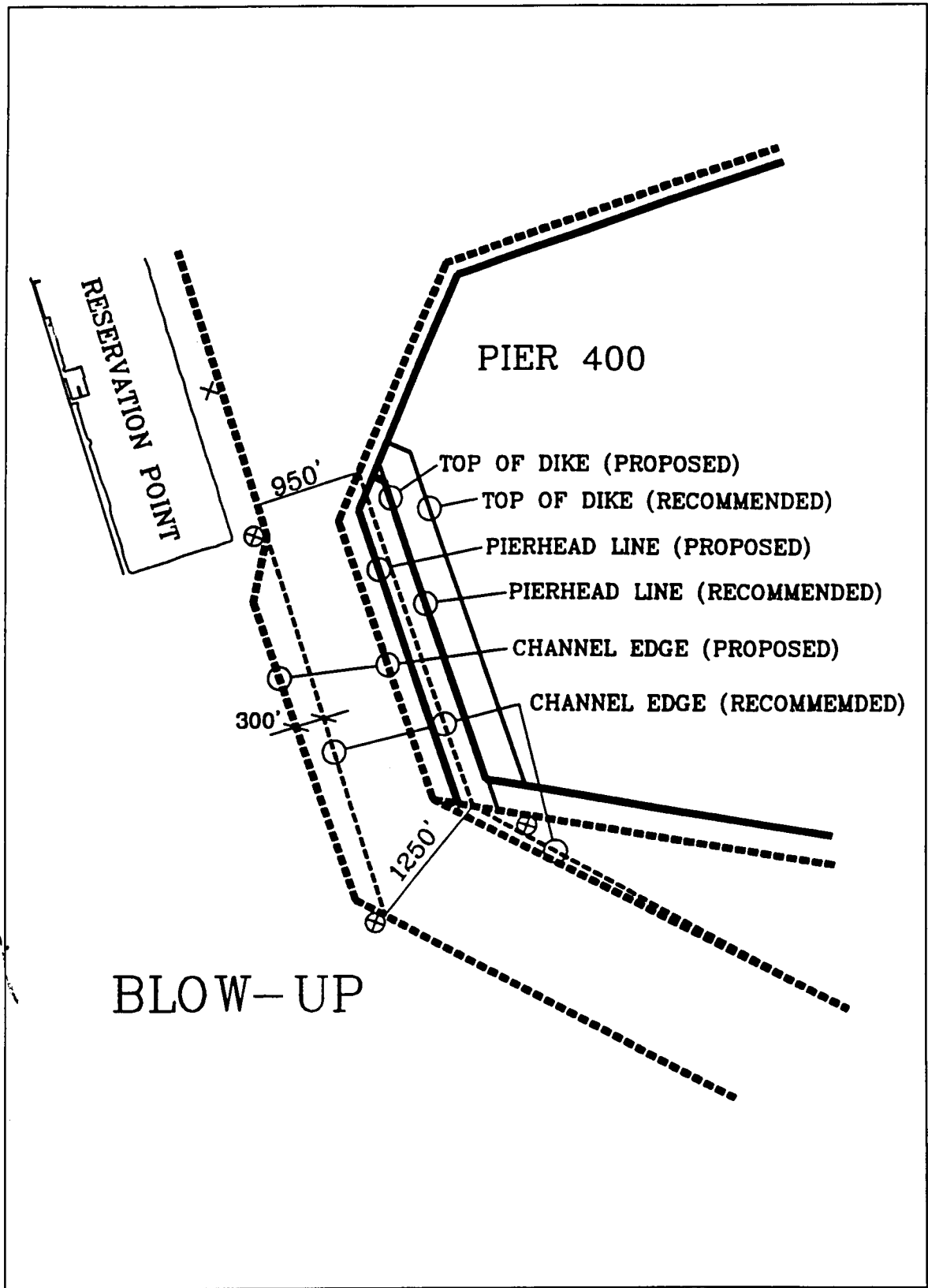

Figure 13b. Blow-up from Figure 13a

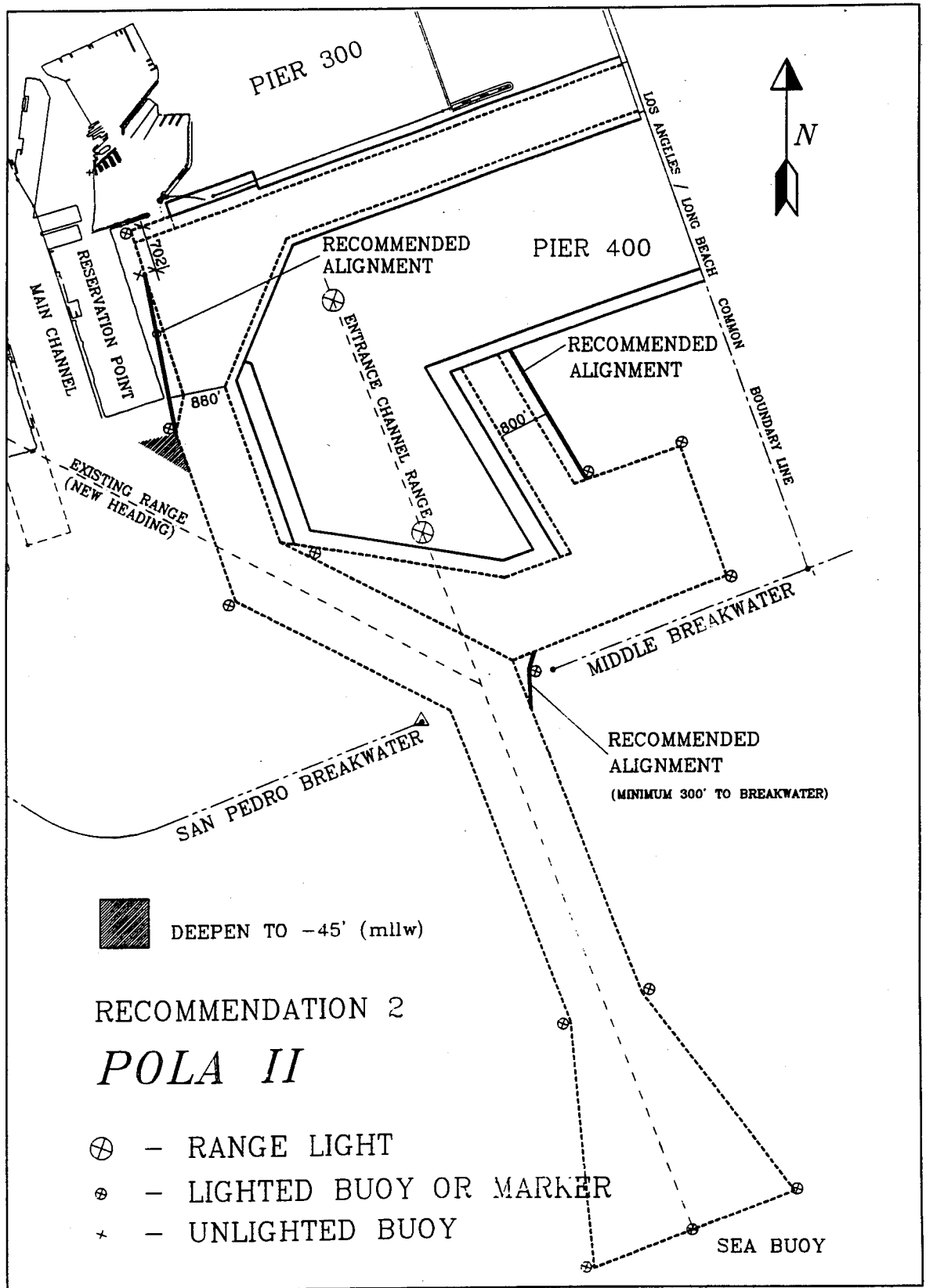

Figure 14. POLA II Recommendation 2

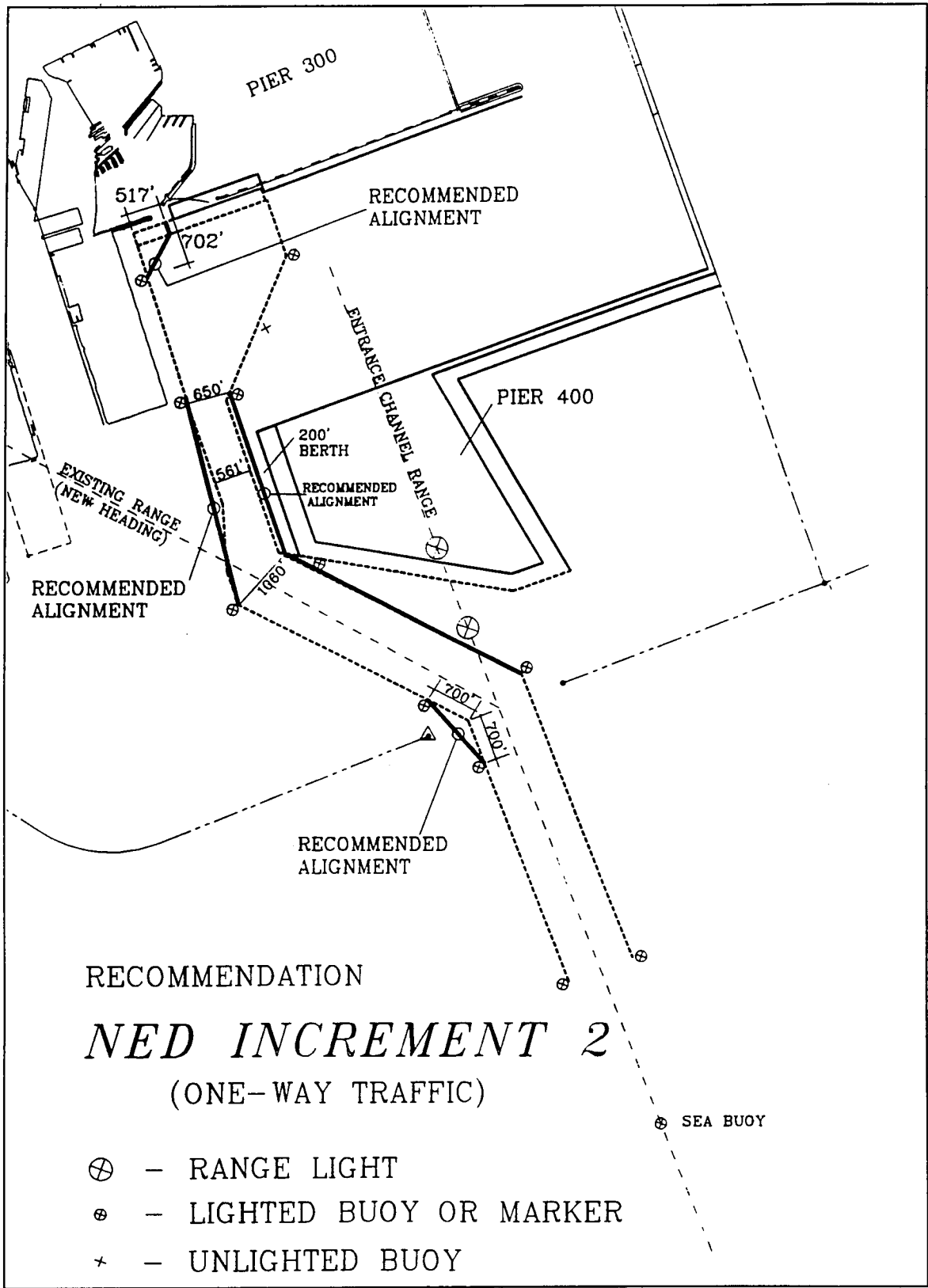

Figure 15. NED 2 Recommendation

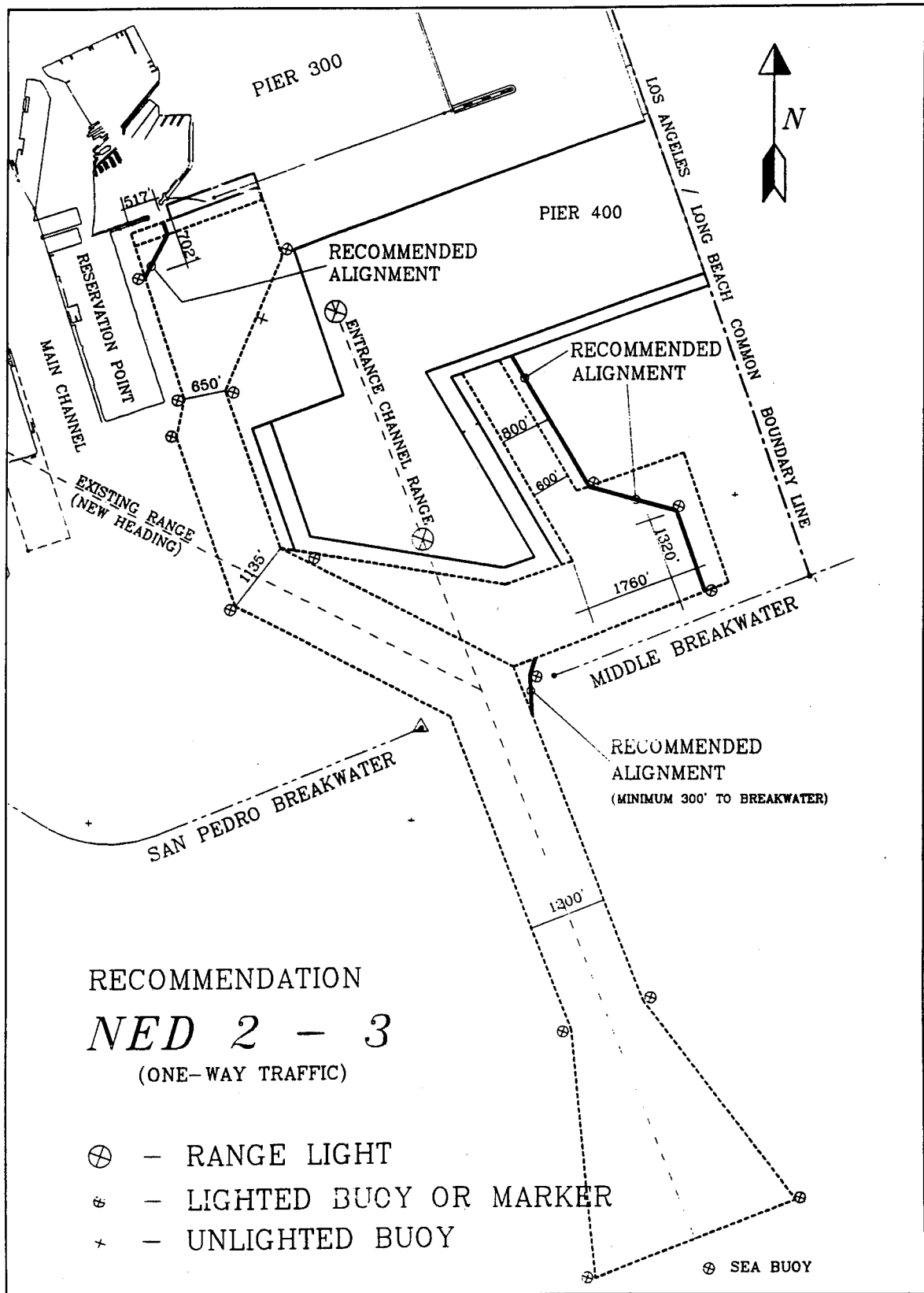

Figure 16. NED 2-3 Recommendation

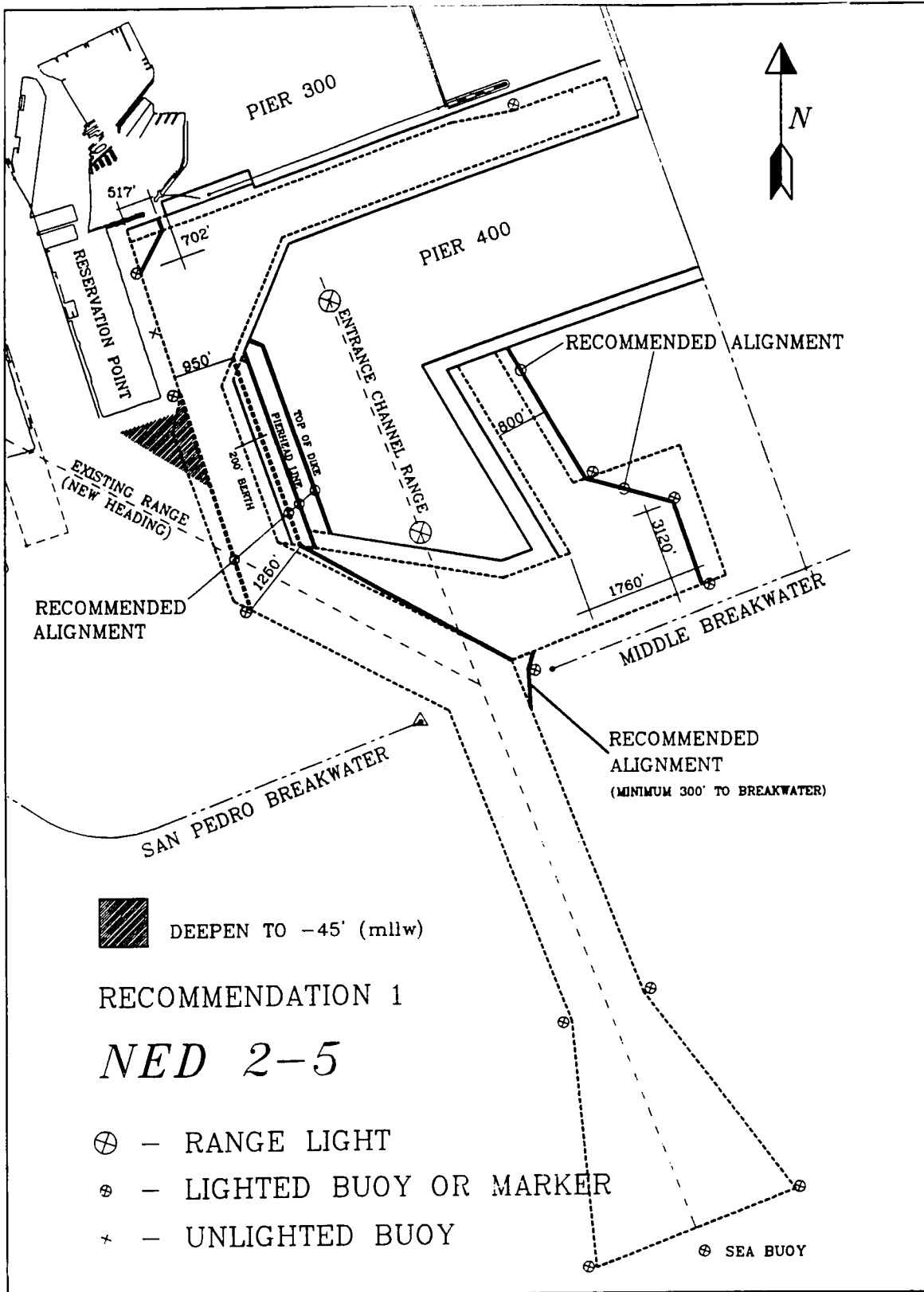

Figure 17. NED 2-5 Recommendation 1

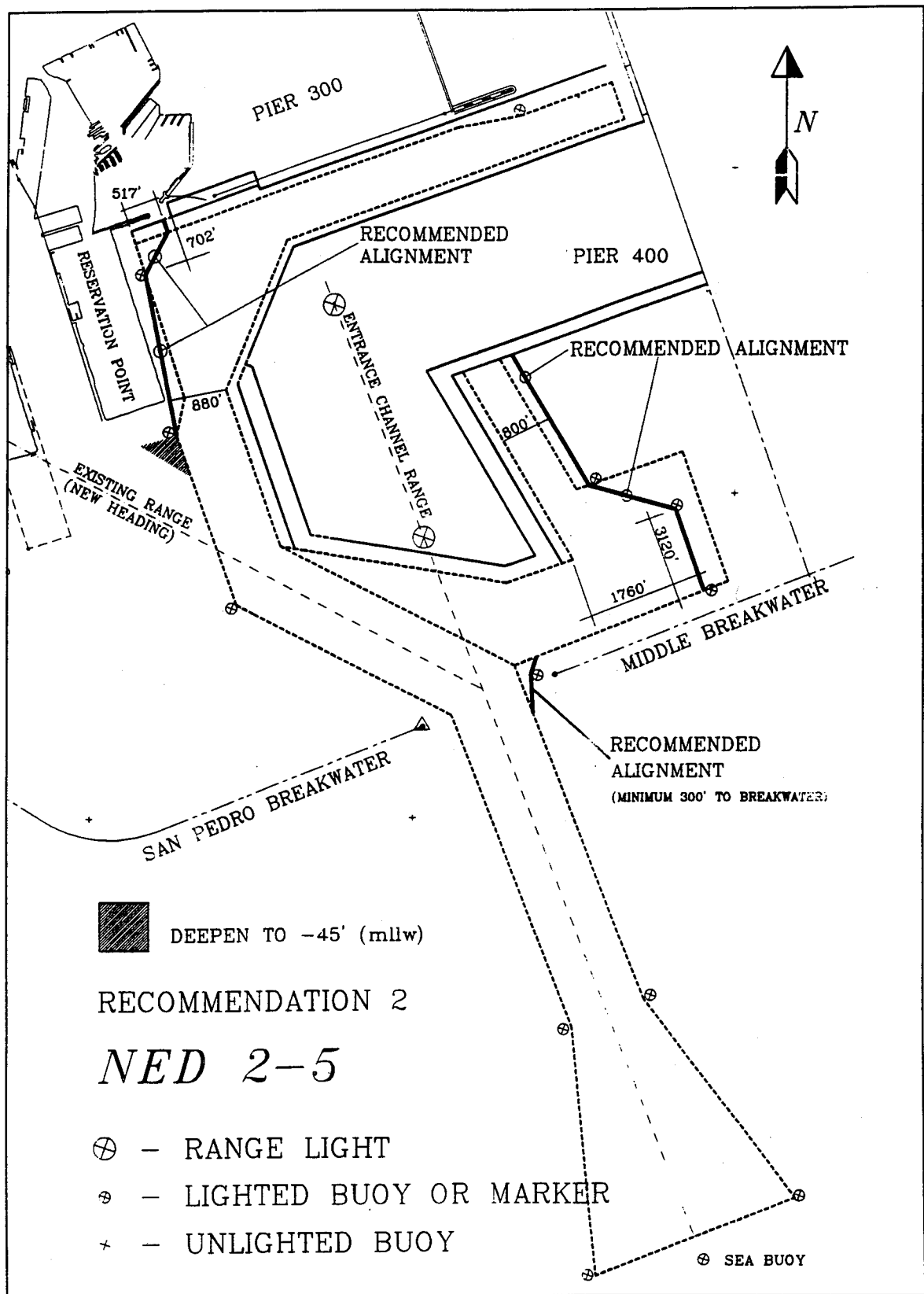

Figure 18. NED 2-3 Recommendation 2

- c. Deepen water adjacent to the western side of the channel along Pier 400 to -45 ft (mllw). This will permit pilots to follow different meeting/passing strategies by allowing the containerships to travel outside of the deep channel.
- d. Aids to navigation as shown on the figures.

## **POLA II**

### **Study conclusions**

- a. Two-way containership traffic is safe throughout the channel except in the vicinity of the proposed constriction at Reservation Point. With no design modifications, operational restrictions will be required on two-way traffic in this area.
- b. One-way traffic for the design tankers and bulk carriers is safe in Main Channel.
- c. The right turn into the South Basin area for the design tankers is feasible. Under the test condition of perfectly operating machinery the pilots were able to make the turn with a minimum of tug control. However, some of the pilots expressed concerns about this maneuver. There may be some delays for this maneuver due to wind, wave and current conditions.
- d. More maneuvering room is needed for backing into Southern Slip.
- e. The pilots should be able to pass any vessel docked at one of the proposed berths without causing damage to the mooring system.

### **Design recommendations**

- a. Widen or straighten the constriction at Reservation Point for allowance of two-way containership traffic. Two alternatives are shown on Figures 13 & 14.
- b. Construct a bend cut-off at Angels Gate on the eastern side of the channel. This would allow ships to get a "head start" on the right turn into South Basin.
- c. Widen Southern Slip an additional 200 ft to ease difficulties with the backing maneuver.
- d. Deepen water adjacent to the western side of the channel along Pier 400 to -45 ft (mllw). This will permit pilots to follow different meeting/

passing strategies by allowing the containerships to travel outside of the deep channel.

- e.* Aids to navigation as shown on the figures.

## **NED 2**

### **Study conclusions**

- a.* The part of the proposed Main Channel adjacent to Pier 400 is too narrow for safe operation of one-way design bulk carrier traffic.
- b.* The outbound bulk carrier runs indicate the need for extra maneuvering room in Angels Gate. This partly results from the late turn caused by the narrow channel adjacent to Pier 400.
- c.* Northwest corner of the proposed turning basin is not usable to pilots.
- d.* The pilots should be able to pass any vessel docked at one of the proposed berths without causing damage to the mooring system.

### **Design recommendations**

- a.* In the Pier 400 vicinity widen the proposed minimum width of 561 ft to a width of 650 ft and uniformly taper the channel to the bend width. Figure 15 details the recommendations in this area.
- b.* Construct a bend cut-off on the inside of the bend at Angels Gate. This will allow ships to start the turn earlier.
- c.* Do not dredge northwest corner of turning basin. Details are shown on Figure 15.
- d.* Aids to navigation as shown on the figure.

## **NED 2-3**

### **Study conclusions**

- a.* One-way traffic for the design tankers and bulk carriers is safe in the Main Channel and the entrance channel. Narrowing is not advisable in these reaches. Again, the northwest corner of the proposed turning basin between Piers 300 and 400 is not usable and should not be dredged.

- b.* The full 2150-ft diameter of South Basin is not needed for the design tankers backing into the Southern Slip.
- c.* The right turn into the South Basin area for the design tankers is feasible. Under the test condition of perfectly operating machinery the pilots were able to make the turn with a minimum of tug control. However, some of the pilots expressed concerns about this maneuver. There may be some delays for this maneuver due to wind, wave and current conditions.
- d.* More maneuvering room is needed for backing into Southern Slip.
- e.* The pilots should be able to pass any vessel docked at one of the proposed berths without causing damage to the mooring system.

### **Design recommendations**

- a.* Leave channel width as proposed in Main Channel except do not dredge northwest corner of the turning basin. Details are shown on Figure 16.
- b.* Construct a bend cut-off at Angels Gate on the eastern side of the channel. This would allow the ships to get a "head start" on the right turn into South Basin.
- c.* Widen Southern Slip an additional 200 ft to ease difficulties with the backing maneuver.
- d.* The eastern channel edge of South Basin should be redesigned as shown on Figure 16.
- e.* Aids to navigation as shown on the figure.

## **NED 2-5**

### **Study conclusions**

- a.* One-way traffic for the design tankers and bulk carriers is safe in Main Channel and the entrance channel. Narrowing is not advisable in these reaches. Again, the northwest corner of the proposed turning basin between Piers 300 and 400 is not usable and should not be dredged.
- b.* The full 2150-ft diameter of South Basin is not needed for the design tankers backing into the Southern Slip.
- c.* The right turn into the South Basin area for the design tankers is feasible. Under the test condition of perfectly operating machinery the

pilots were able to make the turn with a minimum of tug control. However, some of the pilots expressed concerns about this maneuver. There may be some delays for this maneuver due to wind, wave and current conditions.

- d.* More maneuvering room is needed for backing into Southern Slip.
- e.* Two-way containership traffic is safe throughout the channel except in the vicinity of the proposed constriction at Reservation Point. With no design modifications, operational restrictions will be required on two-way traffic in this area.
- f.* The pilots should be able to pass any vessel docked at one of the proposed berths without causing damage to the mooring system.

### **Design recommendations**

- a.* Widen or straighten the constriction at Reservation Point for allowance of two-way containership traffic. Two alternatives are shown on Figures 17 & 18.
- b.* Construct a bend cut-off at Angels Gate on the eastern side of the channel. This would allow ships to get a "head start" on the right turn into South Basin.
- c.* Widen Southern Slip an additional 200 ft to ease difficulties with the backing maneuver.
- d.* Deepen water adjacent to the western side of the channel along Pier 400 to -45 ft (mllw). This will permit pilots to follow different meeting/passing strategies by allowing the containerships to travel outside of the deep channel.
- e.* Aids to navigation as shown on the figures.

### **General Study Conclusions**

- a.* The simulation study indicated that ships could pass moored ships at Pier 400 without causing line breakage. The worst condition evident in the simulation tests for passing ship effects was during the meeting/passing maneuvers between two containerships in the channel adjacent to a docked tanker at Pier 400 West. The one-way traffic tests with the larger tankers and bulk carriers passing the same moored vessels resulted in lower interaction effects than in the two-way traffic scenarios because of the lower speeds and greater passing distances.

- b.* Generally, the number and size of the tug boats used in the simulations was adequate for the maneuvers required. Generally, the pilots used all four available tugs during inbound runs for the tankers and bulk carriers heading into the northern turning basin. Outbound runs for the same ships sometimes required fewer tugs; however, all four tugs remained available. The only area for which the need for additional power and tug capabilities may be anticipated is in Angels Gate when large tankers are making the sharp right turn into South Basin.

# References

---

- Ankudinov, V. (1988). "Mathematical and computer models for predicting ship-ship interaction for use on WES ship maneuvering simulator," Tracor Hydronautics Technical Report 87018.0124, Tracor Hydronautics, Inc., Laurel, Maryland.
- Ankudinov, V. (1994). "Numerical models of ships for Los Angeles Harbor," Designers and Planners, Inc. (D&P), Alexandria, Virginia. in preparation
- Bottin, R. R. and Tolliver, L. R. (1989). "Wave conditions for proposed harbor development in Los Angeles Outer Harbor, Los Angeles, California," WES Technical Report TR-CERC-89-13, Coastal Engineering Research Center, Vicksburg, Mississippi.
- Bruun, P. (1989). *Port engineering, Volume 1, harbor planning, breakwaters, and marine terminals.*, 4th ed., Gulf Publishing, Houston, Texas, 1208-1240.
- Pizzariello, C. and Hwang, W. (1989). "Simulation study of alternative channel designs for Los Angeles Harbor 2020 Plan-Angels Gate, final report," Marine Safety International, Inc., Kingspoint, New York.
- Seabergh, W. C., Vemulakonda, S. R., Chou, L. W. and Mark, D. J. (1994). "Los Angeles and Long Beach Harbors, Model Enhancement Program, effects of wind on circulation on Los Angeles-Long Beach Harbors, Appendix A: winds on San Pedro Breakwater," WES Technical Report, TR-CERC-94-7, Coastal Engineering Research Center, Vicksburg, Mississippi.
- Wang H. (1994). "Numerical hydrodynamic modeling in support of water quality and ship simulation in Los Angeles," WES Technical Report, Coastal Engineering Research Center, Vicksburg, Mississippi, in preparation.

### Scenario - Trackplot Reference Key

| Channel             | Ship | Travel Dir. | Wind | Tide  | Individual Trackplots | Associated Composite Trackplots |
|---------------------|------|-------------|------|-------|-----------------------|---------------------------------|
| <b>PHASE 1</b>      |      |             |      |       |                       |                                 |
| <b>FULL LENGTH</b>  |      |             |      |       |                       |                                 |
| POLA I              | C10  | TWO-WAY     | SE   | EBB   | 108-109               | -                               |
| POLA I              | "    | "           | WSW  | FLOOD | 110                   | -                               |
| POLA II             | "    | "           | "    | EBB   | 111                   | -                               |
| POLA II             | "    | "           | "    | FLOOD | 112                   | -                               |
| NED 2-5             | "    | "           | "    | EBB   | 113-114               | -                               |
| NED 2-5             | "    | "           | "    | FLOOD | 115-116               | -                               |
| <b>ANGELS GATE</b>  |      |             |      |       |                       |                                 |
| POLA I              | C10  | TWO-WAY     | SE   | EBB   | 117-118               | 25 & 27                         |
| POLA I              | "    | "           | WES  | "     | 119-122               | 25 & 27                         |
| POLA I              | "    | "           | SE   | FLOOD | 123-124               | 26 & 27                         |
| POLA I              | "    | "           | WSW  | "     | 125-127               | 26 & 27                         |
| POLA II             | "    | "           | "    | EBB   | 128-129               | 28 & 30                         |
| POLA II             | "    | "           | "    | FLOOD | 130-131               | 29 & 30                         |
| NED 2-5             | "    | "           | "    | EBB   | 132-133               | 31 & 33                         |
| NED 2-5             | "    | "           | "    | FLOOD | 134-135               | 32 & 33                         |
| <b>CHANNEL BEND</b> |      |             |      |       |                       |                                 |
| POLA I              | C10  | TWO-WAY     | WSW  | EBB   | 136-137               | 34 & 36                         |
| POLA I              | "    | "           | "    | FLOOD | 138-139               | 35 & 36                         |
| POLA II             | "    | "           | "    | EBB   | 140-141               | 37 & 39                         |
| POLA II             | "    | "           | "    | FLOOD | 142-143               | 38 & 39                         |
| NED 2-5             | "    | "           | SE   | EBB   | 144-145               | 40 & 42                         |
| NED 2-5             | "    | "           | WSW  | "     | 146-147               | 40 & 42                         |
| NED 2-5             | "    | "           | SE   | FLOOD | 148-149               | 41 & 42                         |
| NED 2-5             | "    | "           | WSW  | FLOOD | 150                   | 41 & 42                         |
| <b>PIER 400</b>     |      |             |      |       |                       |                                 |
| POLA I              | C10  | "           | WSW  | EBB   | 151-152               | 43 & 45                         |
| POLA I              | "    | "           | "    | FLOOD | 153 & 154             | 44 & 45                         |
| POLA II             | "    | "           | "    | EBB   | 155 & 156             | 46 & 48                         |

**Scenario - Trackplot Reference Key (Continued)**

| Channel                    | Ship | Travel Dir. | Wind | Tide  | Individual Trackplots | Associated Composite Trackplots |
|----------------------------|------|-------------|------|-------|-----------------------|---------------------------------|
| <b>PHASE 1 (Continued)</b> |      |             |      |       |                       |                                 |
| <b>PIER 400 (Cont)</b>     |      |             |      |       |                       |                                 |
| POLA II                    | C10  | TWO-WAY     | WSW  | FLOOD | 157 & 158             | 47 & 48                         |
| NED 2-5                    | "    | "           | "    | EBB   | 159 & 160             | 49 & 51                         |
| NED 2-5                    | "    | "           | "    | FLOOD | 161 & 162             | 50 & 51                         |
| <b>CONSTRICTION</b>        |      |             |      |       |                       |                                 |
| POLA I                     | C10  | TWO-WAY     | WSW  | EBB   | 163-164               | 52 & 54                         |
| POLA I                     | "    | "           | "    | FLOOD | 165-166               | 53 & 54                         |
| POLA II                    | "    | "           | SE   | EBB   | 167-168               | 55 & 57                         |
| POLA II                    | "    | "           | WSW  | "     | 169-170               | 55 & 57                         |
| POLA II                    | "    | "           | SE   | "     | 171-172               | 55 & 57                         |
| POLA II                    | "    | "           | WSW  | FLOOD | 173-174               | 56 & 57                         |
| NED 2-5                    | "    | "           | "    | EBB   | 175-176               | 58 & 60                         |
| NED 2-5                    | "    | "           | SE   | FLOOD | 177-178               | 59 & 60                         |
| NED 2-5                    | "    | "           | WSW  | FLOOD | 179-180               | 59 & 60                         |
| <b>CONT. SLIP</b>          |      |             |      |       |                       |                                 |
| POLA I                     | C10  | TWO-WAY     | WSW  | EBB   | 181                   | 61                              |
| POLA I                     | "    | "           | "    | FLOOD | 182                   | 61                              |
| POLA II                    | "    | "           | WSW  | EBB   | 183                   | 62 & 63                         |
| POLA II                    | "    | "           | SE   | "     | 184                   | 62 & 6                          |
| POLA II                    | "    | "           | "    | FLOOD | 185                   | 63                              |
| NED 2-5                    | "    | "           | WSW  | EBB   | 186                   | 64 & 66                         |
| NED 2-5                    | "    | "           | SE   | "     | 187                   | 64 & 66                         |
| NED 2-5                    | "    | "           | WSW  | FLOOD | 188-189               | 65 & 66                         |
| <b>PHASE 2</b>             |      |             |      |       |                       |                                 |
| <b>POLA I</b>              |      |             |      |       |                       |                                 |
| PIER 400W                  | T1   | INBOUND     | BASE | EBB   | 190                   | 67                              |
| "                          | "    | "           | SE   | "     | 191                   | 67                              |
| "                          | "    | "           | SE   | FLOOD | 192                   | 67                              |
| "                          | "    | "           | WSW  | EBB   | 193                   | 67                              |

**Scenario - Trackplot Reference Key (Continued)**

| Channel                    | Ship | Travel Dir. | Wind | Tide  | Individual Trackplots | Associated Composite Trackplots |
|----------------------------|------|-------------|------|-------|-----------------------|---------------------------------|
| <b>PHASE 2 (Continued)</b> |      |             |      |       |                       |                                 |
| <b>POLA I</b>              |      |             |      |       |                       |                                 |
| PIER 400 W (Cont)          | T1"  | INBOUND     | WSW  | FLOOD | 194                   | 67                              |
| COAL DOCK                  | T2   | OUTBOUND    | BASE | EBB   | 195                   | 68                              |
| "                          | "    | "           | SE   | FLOOD | 196                   | 68                              |
| "                          | "    | "           | WSW  | EBB   | 197                   | 68                              |
| "                          | "    | INBOUND     | BASE | "     | 198                   | 70                              |
| "                          | "    | "           | SE   | "     | 199                   | 70                              |
| "                          | "    | "           | SE   | FLOOD | 200-201               | 69 & 70                         |
| "                          | "    | "           | WSW  | EBB   | 202                   | 70                              |
| "                          | "    | "           | WSW  | FLOOD | 203                   | 70                              |
| <b>POLA II</b>             |      |             |      |       |                       |                                 |
| PIER 400E                  | T2   | INBOUND     | BASE | FLOOD | 204                   | 74                              |
| "                          | "    | "           | SE   | EBB   | 205-206               | 71 & 74                         |
| "                          | "    | "           | SE   | FLOOD | 207-208               | 72 & 74                         |
| "                          | "    | "           | WSW  | EBB   | 209-210               | 73 & 74                         |
| "                          | "    | "           | "    | FLOOD | 211                   | 74                              |
| PIER 400W                  | T1   | INBOUND     | BASE | EBB   | 212                   | 77                              |
| "                          | "    | "           | SE   | FLOOD | 213-214               | 75 & 77                         |
| "                          | "    | "           | WSW  | EBB   | 215                   | 77                              |
| "                          | "    | "           | WSW  | FLOOD | 216-217               | 76 & 77                         |
| PIER 400E                  | T2   | OUTBOUND    | BASE | EBB   | 218                   | 80                              |
| "                          | "    | "           | SE   |       | 219-221               | 78 & 80                         |
| "                          | "    | "           | "    |       | 222                   | 80                              |
| "                          | "    | "           | WSW  |       | 223                   | 80                              |
| "                          | "    | "           | "    |       | 224-225               | 79 & 80                         |
| COAL DOCK                  | "    | "           | BASE | "     | 226                   | 83                              |
| "                          | "    | "           | SE   | EBB   | 227                   | 83                              |
| "                          | "    | "           | "    | FLOOD | 228-229               | 81 & 83                         |
| "                          | "    | "           | WSW  | EBB   | 230-231               | 82 & 83                         |

**Scenario - Trackplot Reference Key (Concluded)**

| Channel                    | Ship | Travel Dir. | Wind | Tide  | Individual Trackplots | Associated Composite Trackplots |
|----------------------------|------|-------------|------|-------|-----------------------|---------------------------------|
| <b>PHASE 2 (Continued)</b> |      |             |      |       |                       |                                 |
| <b>POLA II</b>             |      |             |      |       |                       |                                 |
| COAL DOCK                  | T2   | OUTBOUND    | WSW  | FLOOD | 232                   | 83                              |
| <b>PHASE 3</b>             |      |             |      |       |                       |                                 |
| <b>NED 2</b>               |      |             |      |       |                       |                                 |
| COAL DOCK                  | BC   | OUTBOUND    | SE   | EBB   | 233-236               | 84 & 88                         |
| "                          | "    | "           | "    | FLOOD | 237-239               | 85 & 88                         |
| "                          | "    | "           | WSW  | EBB   | 240-241               | 86 & 88                         |
| "                          | "    | "           | "    | FLOOD | 242-243               | 87 & 88                         |
| PIER 400 W                 | T3   | INBOUND     | SE   | EBB   | 244-245               | 89 & 92                         |
| "                          | "    | "           | "    | FLOOD | 246-247               | 90 & 92                         |
| "                          | "    | "           | WSW  | EBB   | 248-250               | 91 & 92                         |
| "                          | "    | "           | "    | FLOOD | 251                   | 92                              |
| <b>NED 2-3</b>             |      |             |      |       |                       |                                 |
| PIER 400W                  | T3   | INBOUND     | SE   | EBB   | 252-254               | 93 & 97                         |
| "                          | "    | "           | "    | FLOOD | 255-257               | 94 & 97                         |
| "                          | "    | "           | WSW  | EBB   | 258-260               | 95 & 97                         |
| "                          | "    | "           | "    | FLOOD | 261-262               | 96 & 97                         |
| PIER 400E                  | T4   | "           | SE   | EBB   | 264-265               | 98 & 102                        |
| "                          | "    | "           | "    | FLOOD | 266-269               | 99 & 102                        |
| "                          | "    | "           | WSW  | EBB   | 270-271               | 100 & 102                       |
| "                          | "    | "           | "    | FLOOD | 272-274               | 101 & 102                       |
| "                          | T2   | OUTBOUND    | SE   | EBB   | 275-276               | 103 & 107                       |
| "                          | "    | "           | "    | FLOOD | 277-279               | 104 & 107                       |
| "                          | "    | "           | WSW  | EBB   | 280-282               | 105 & 107                       |
| "                          | "    | "           | "    | FLOOD | 283-285               | 106 & 107                       |

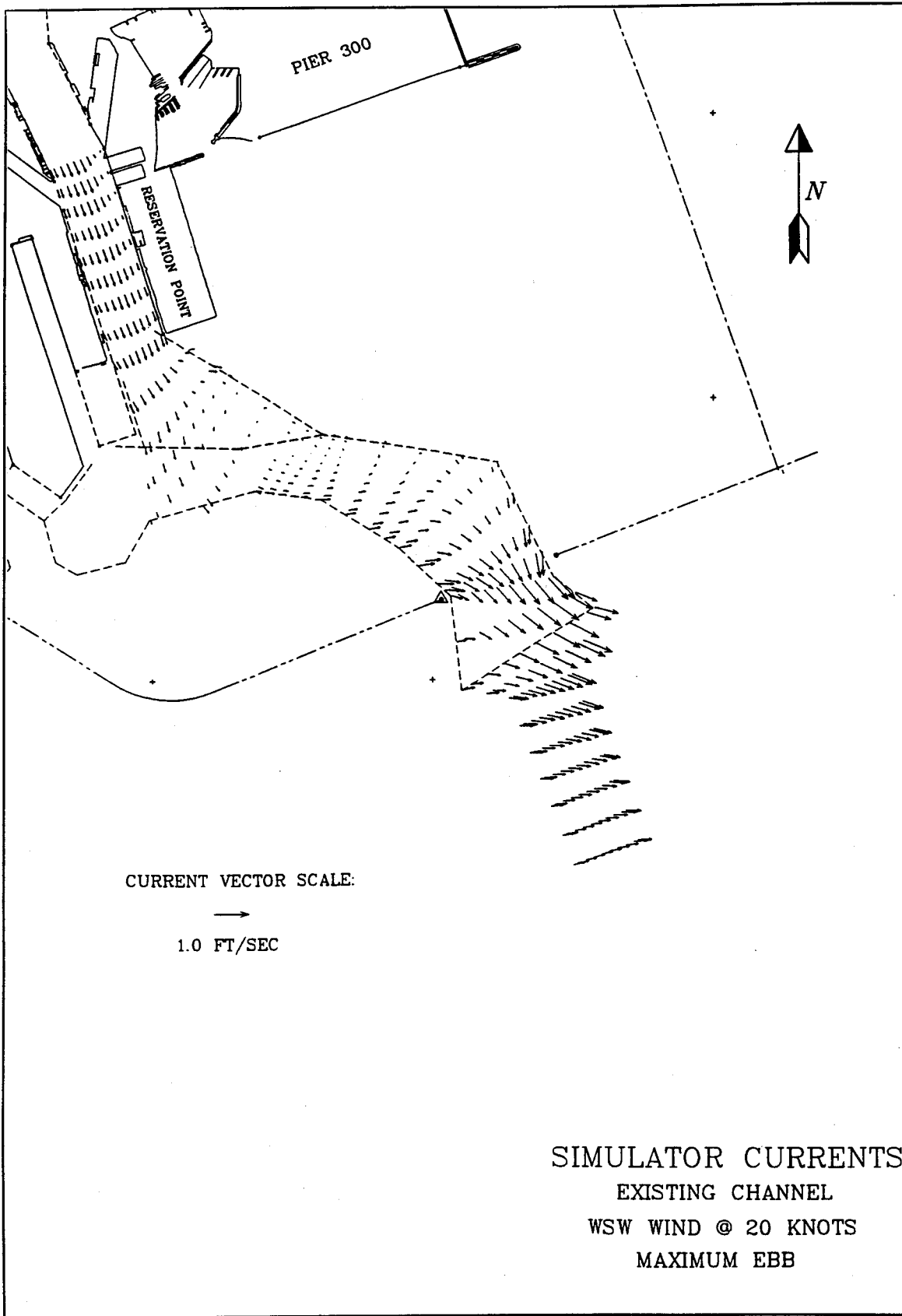

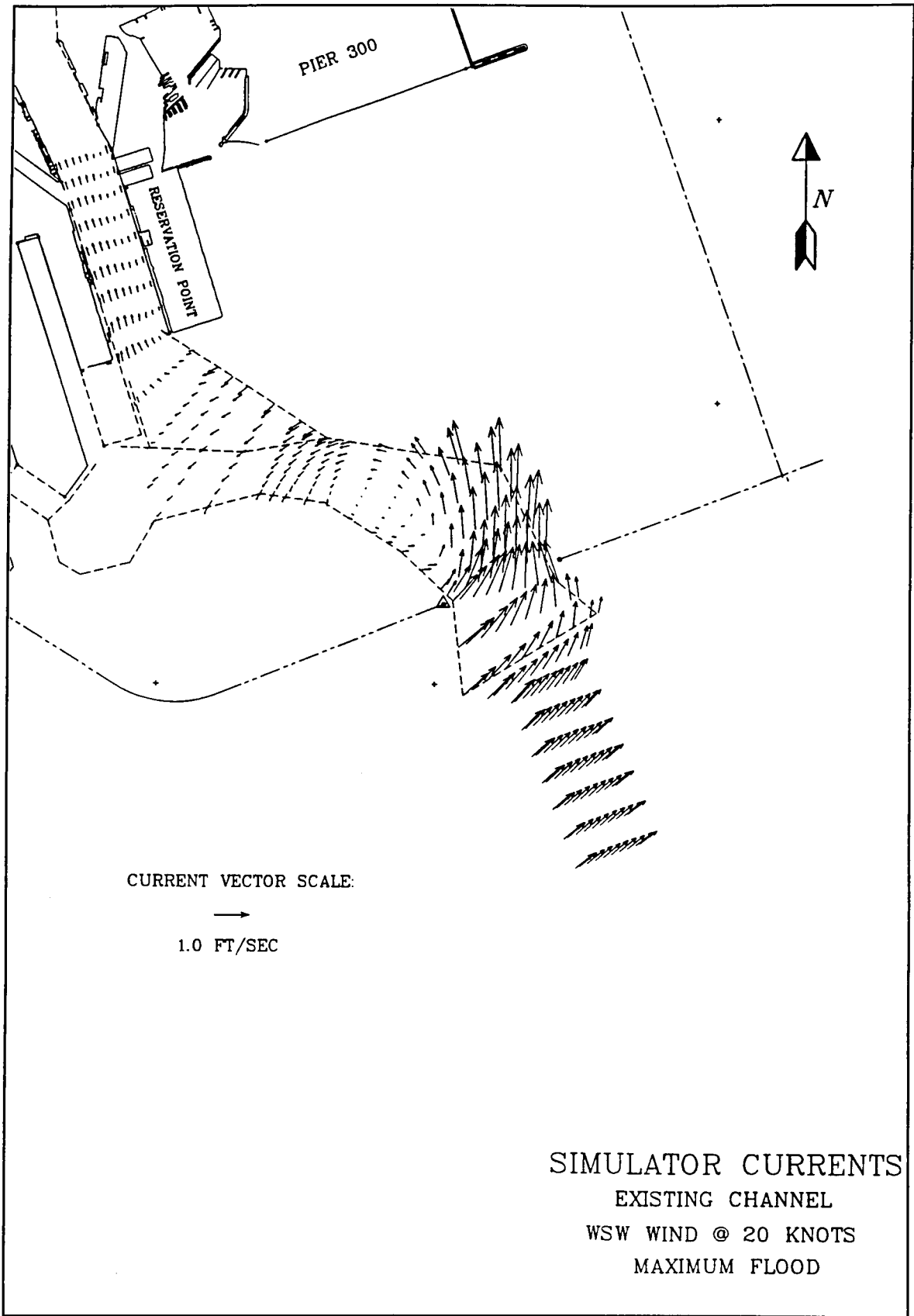
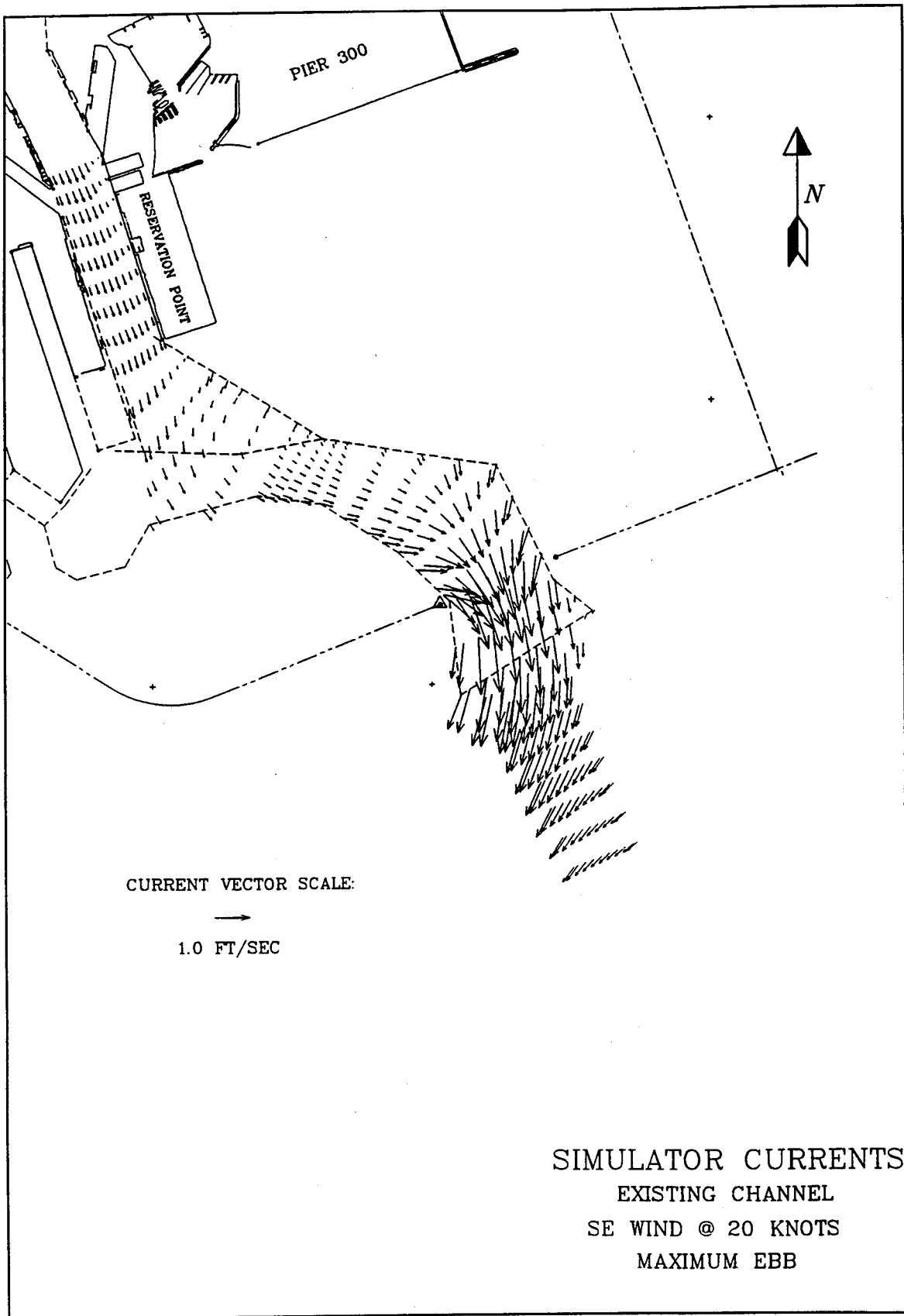

Plate 2



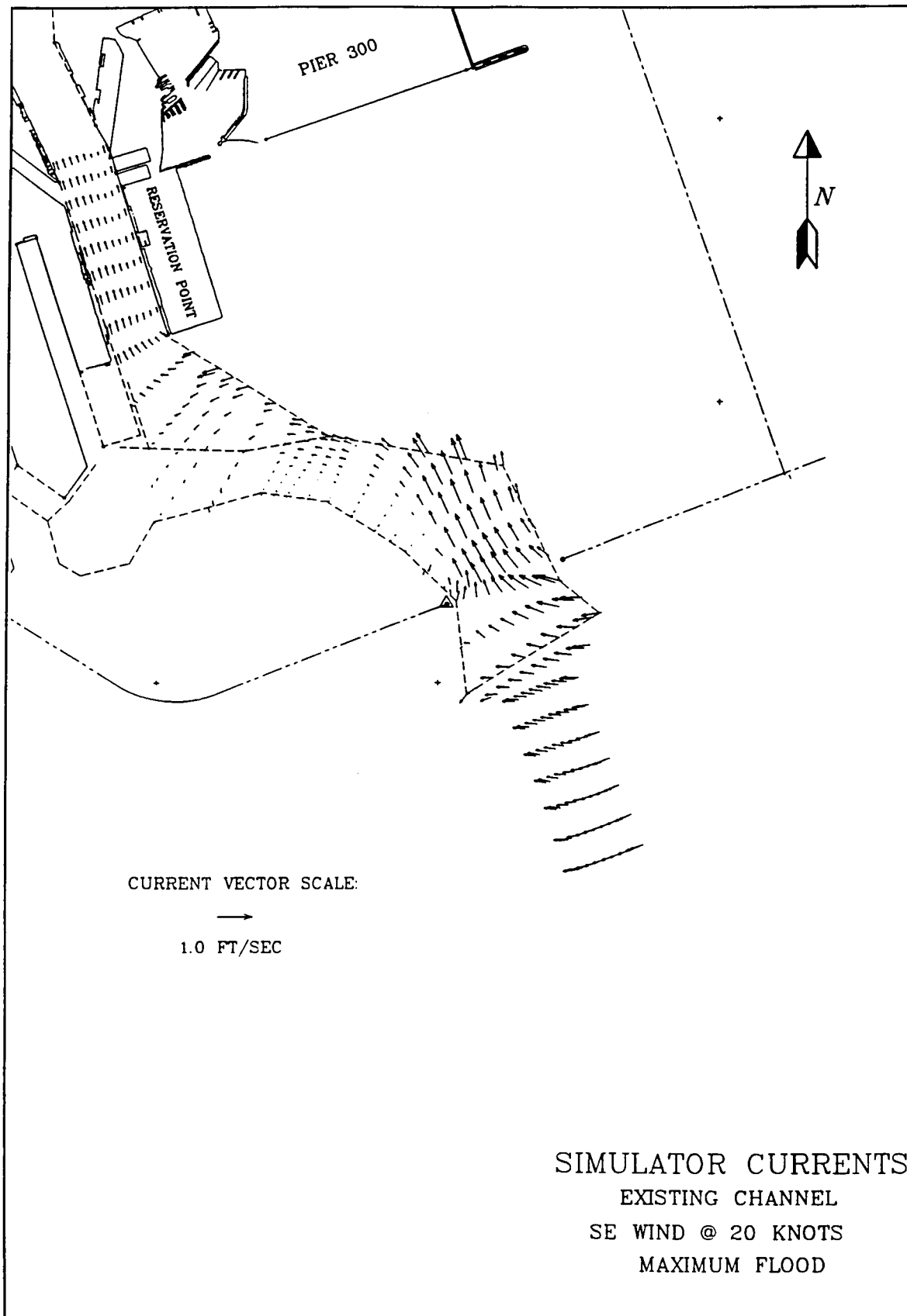
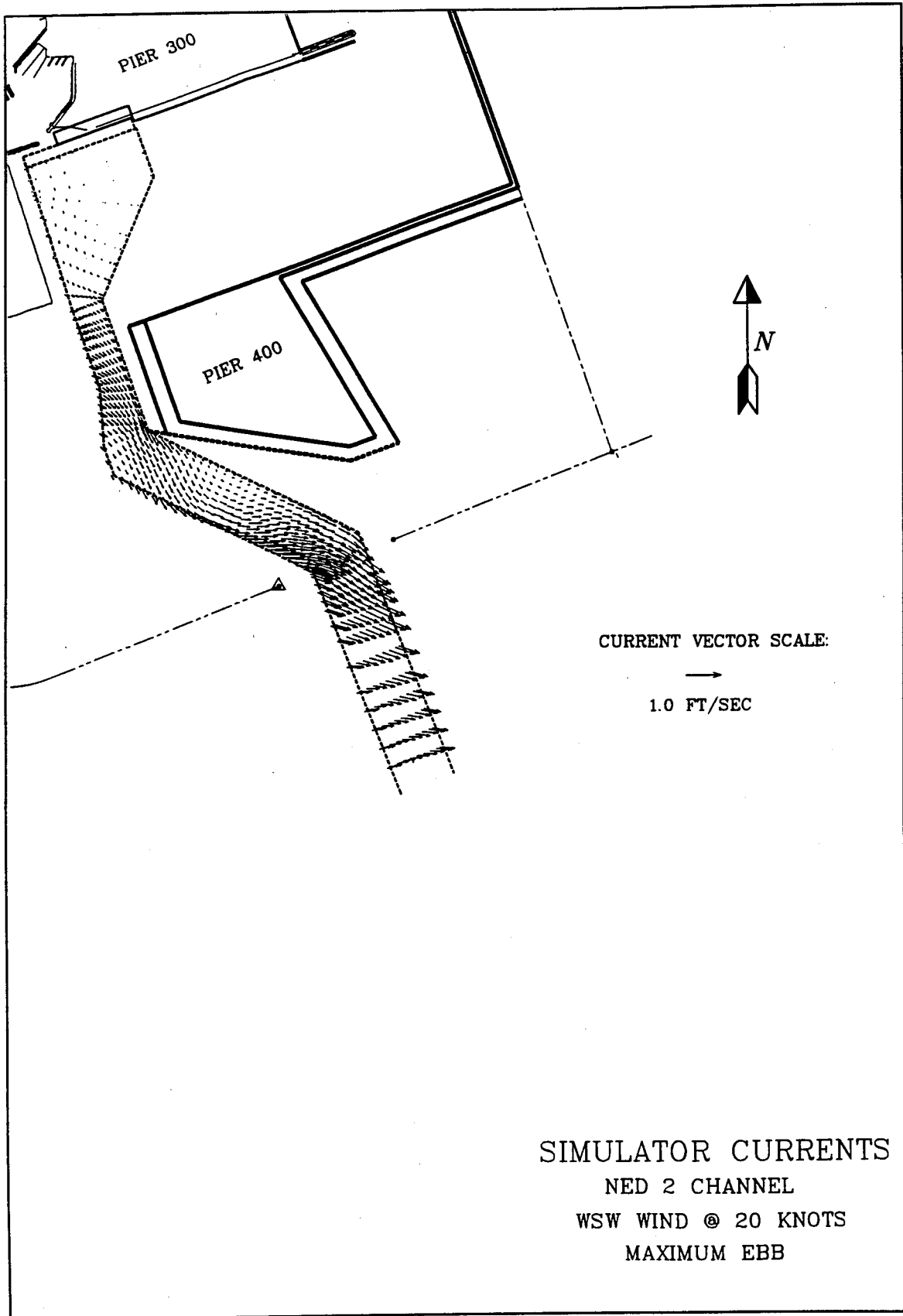

Plate 4



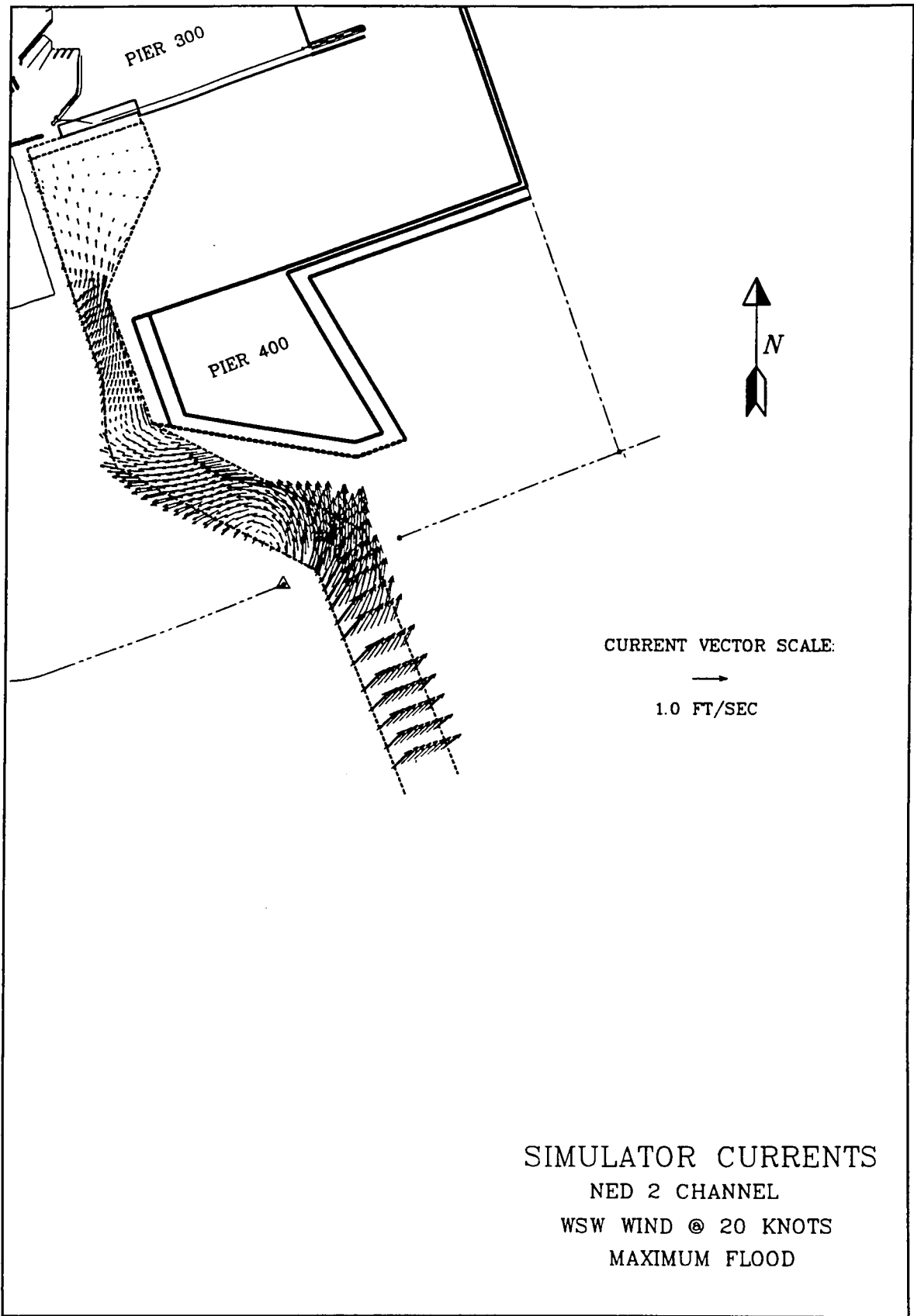
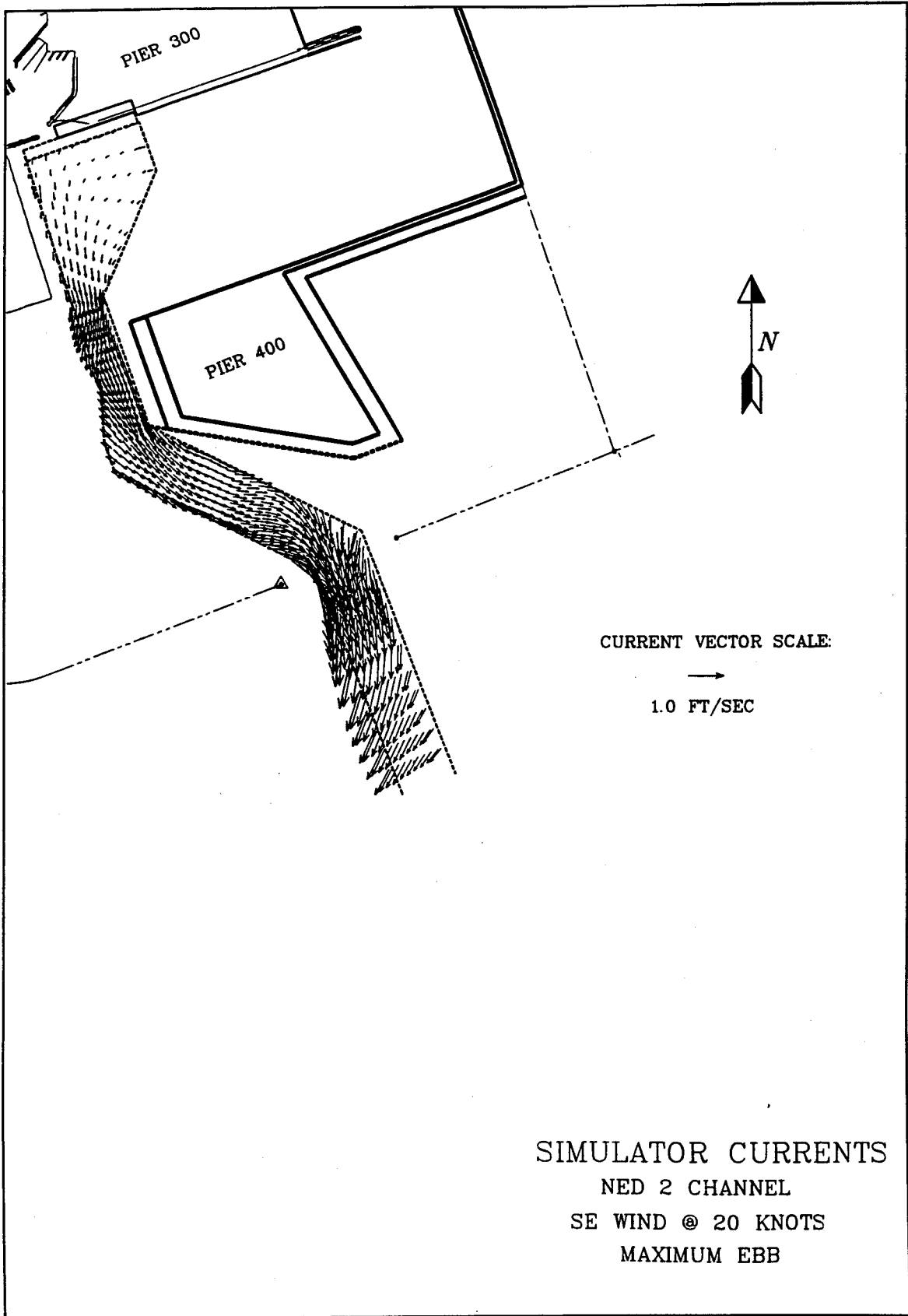

Plate 6



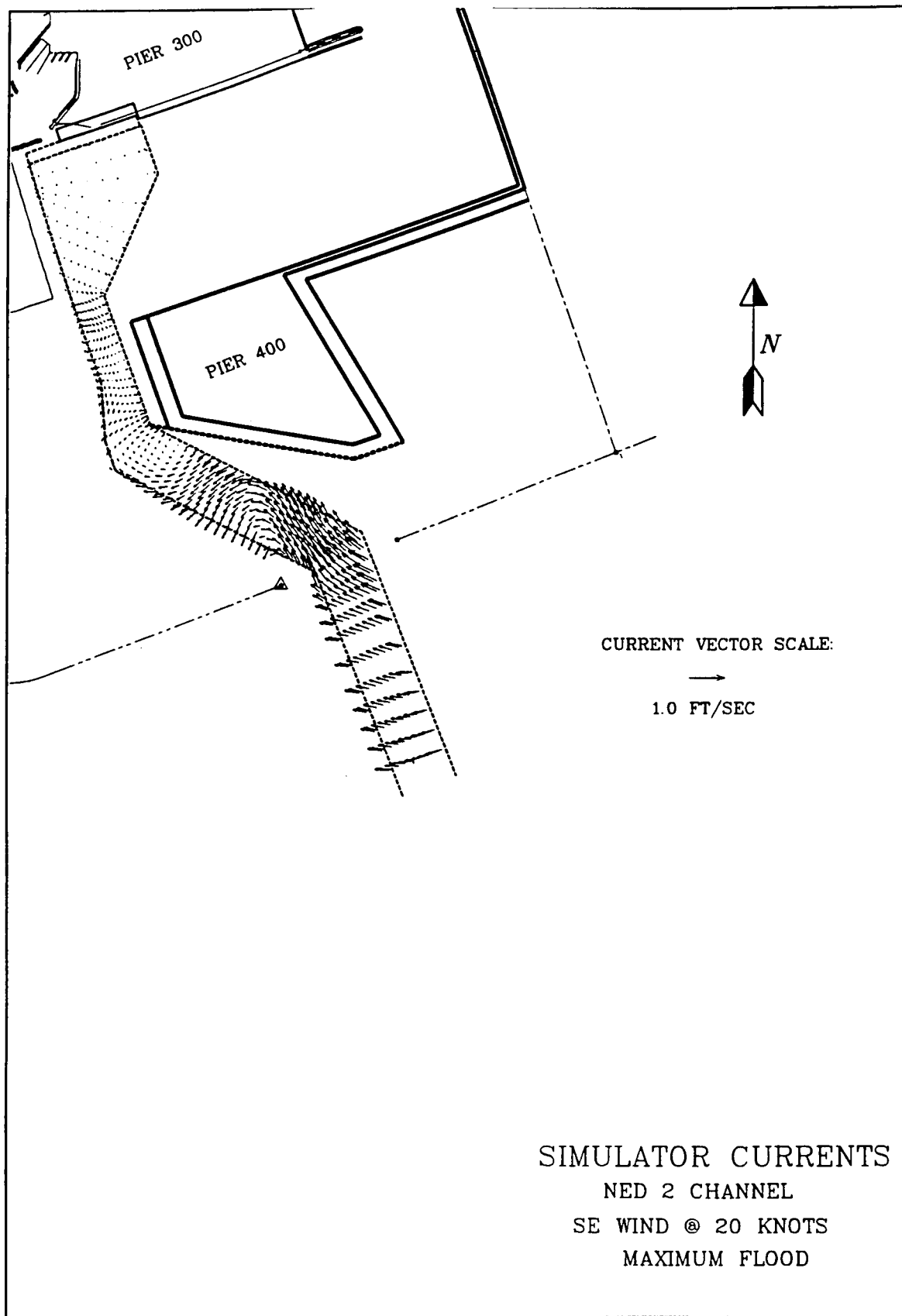
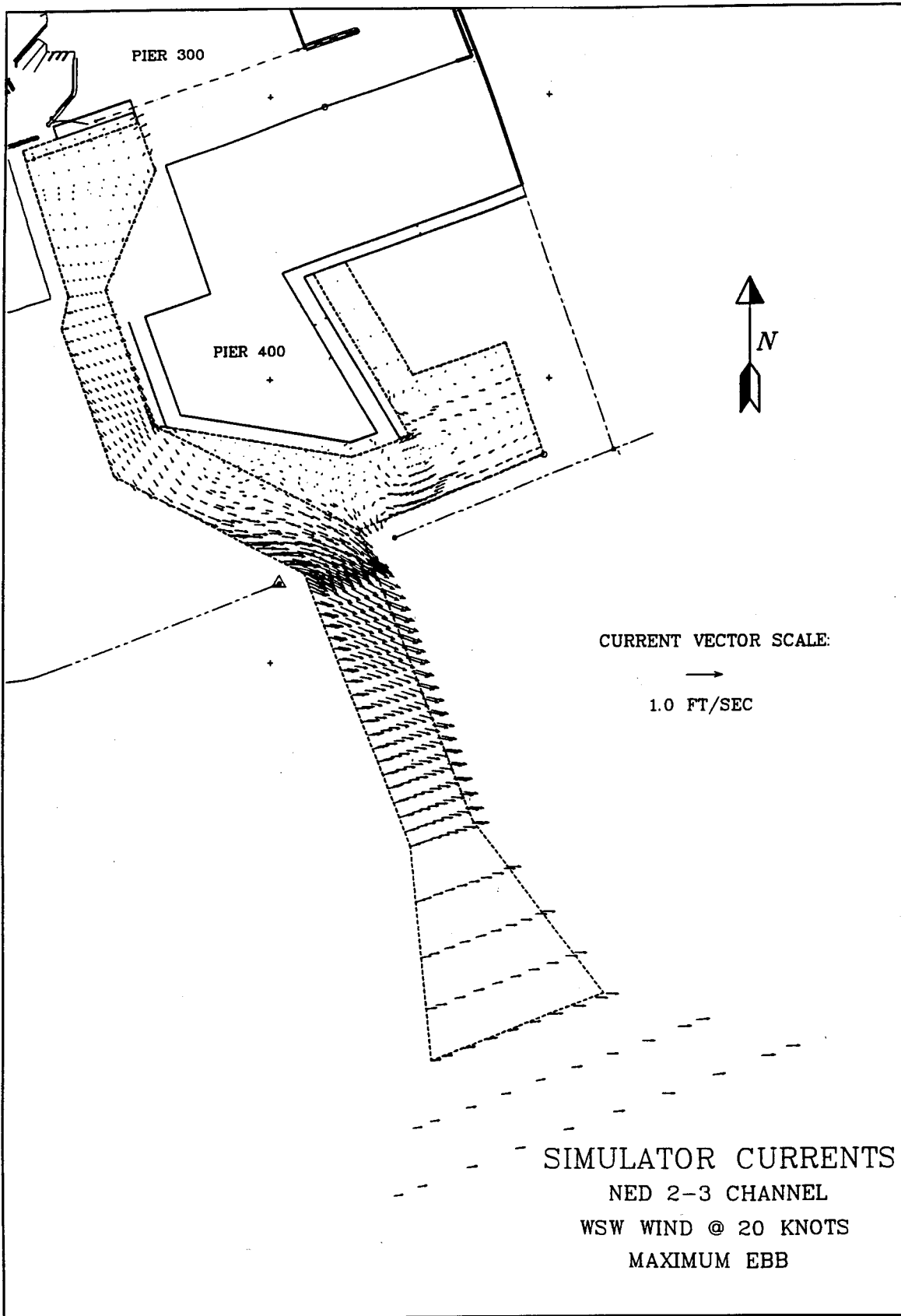

Plate 8



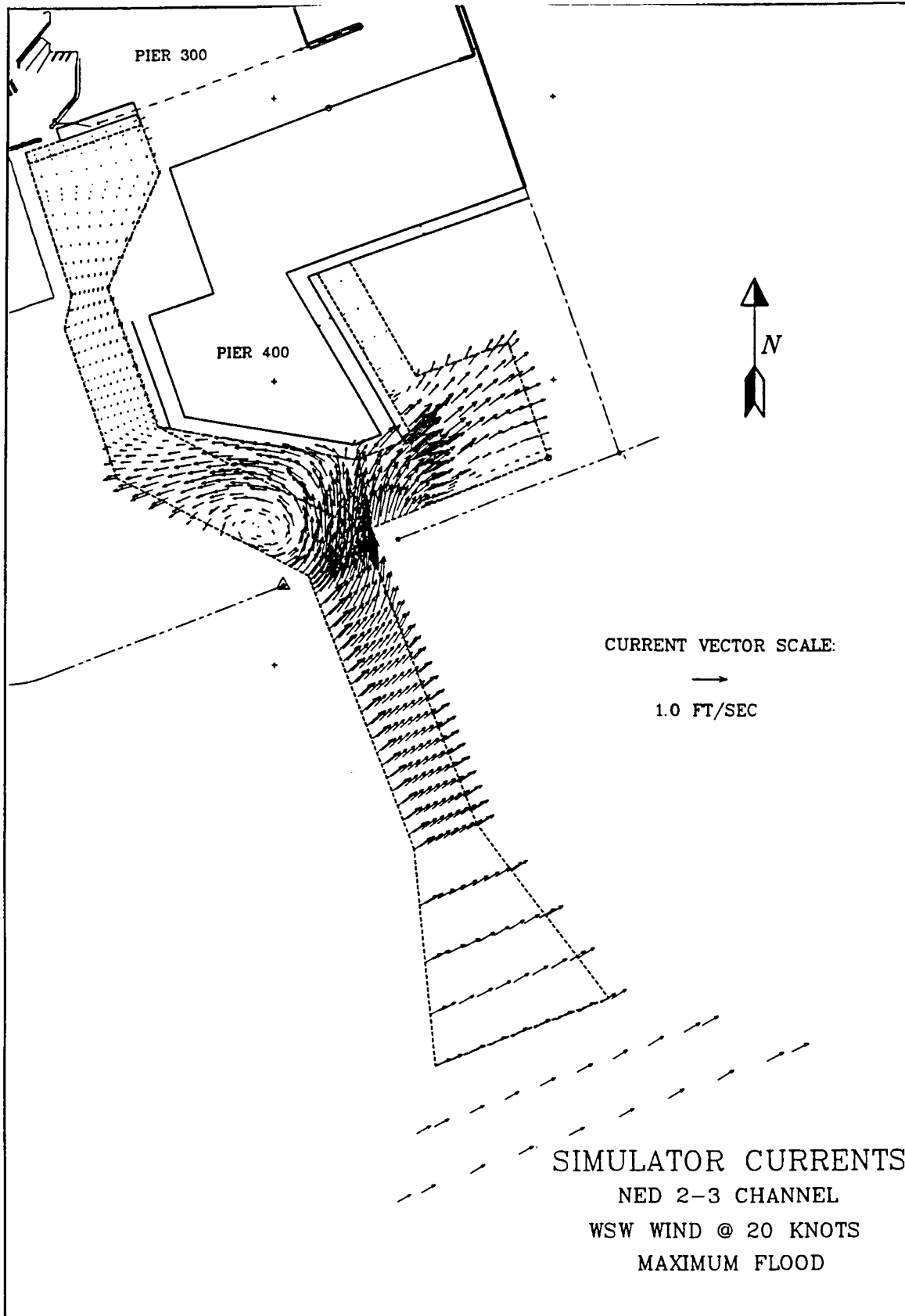
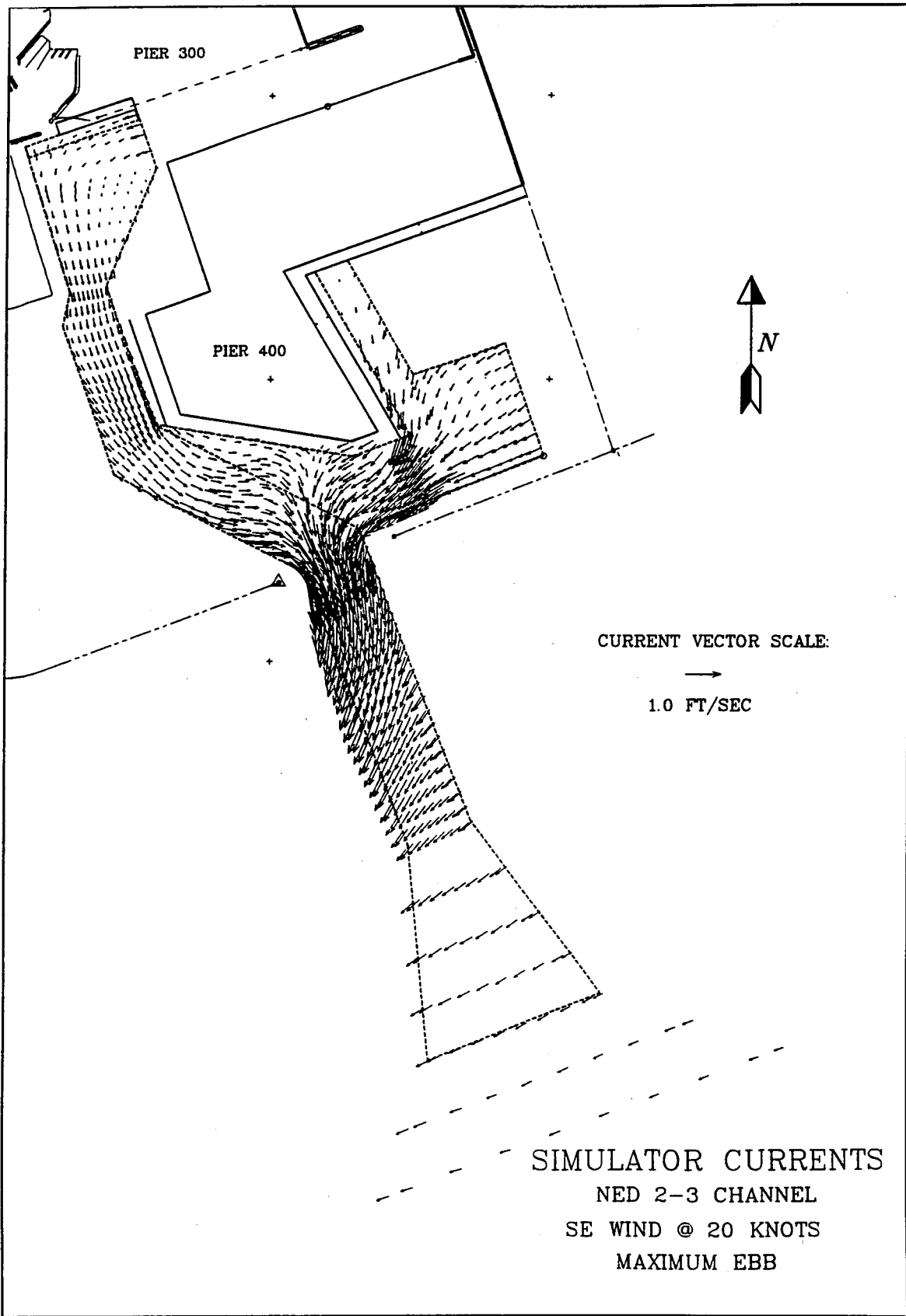

Plate 10



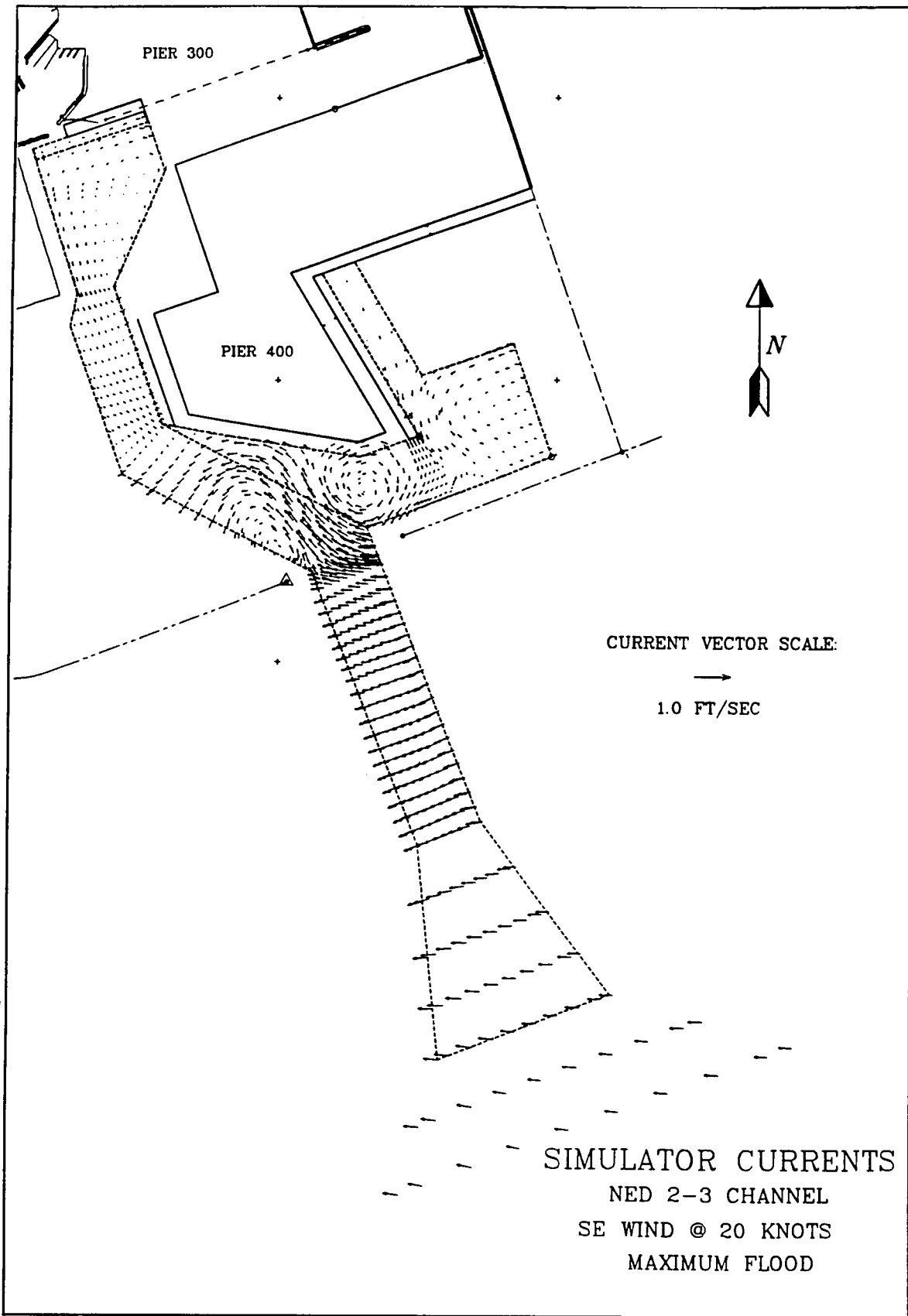
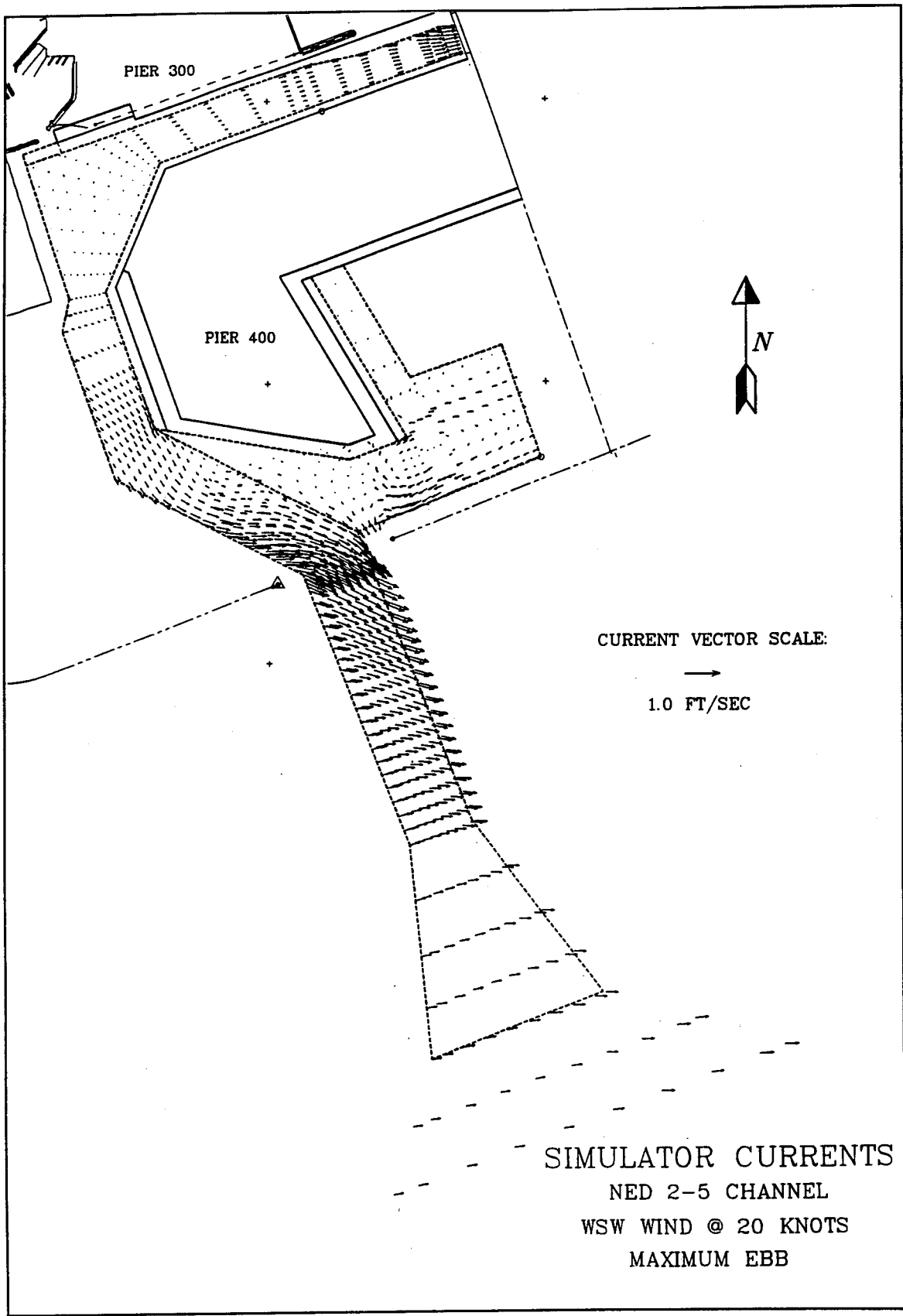

Plate 12



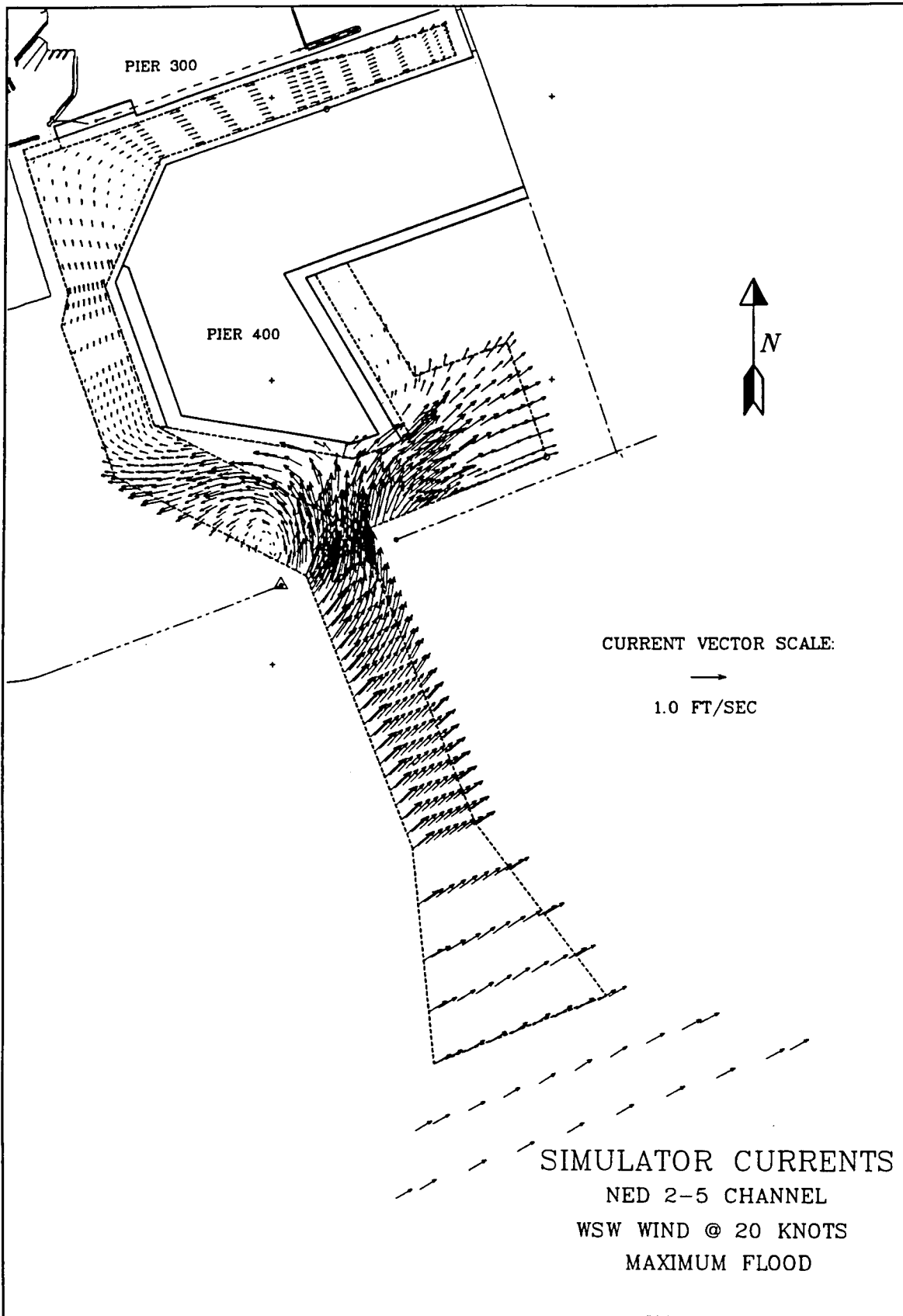
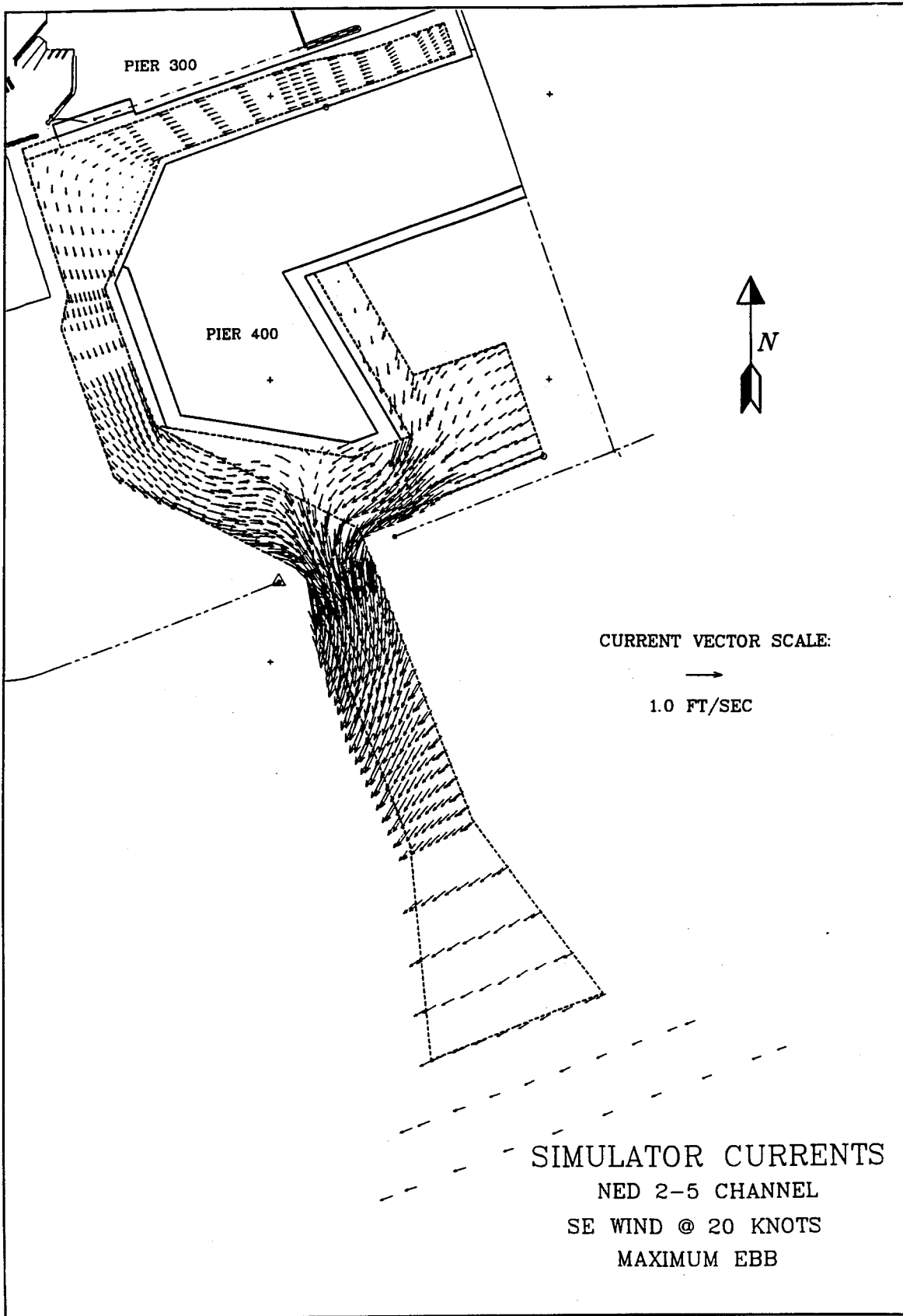

Plate 14



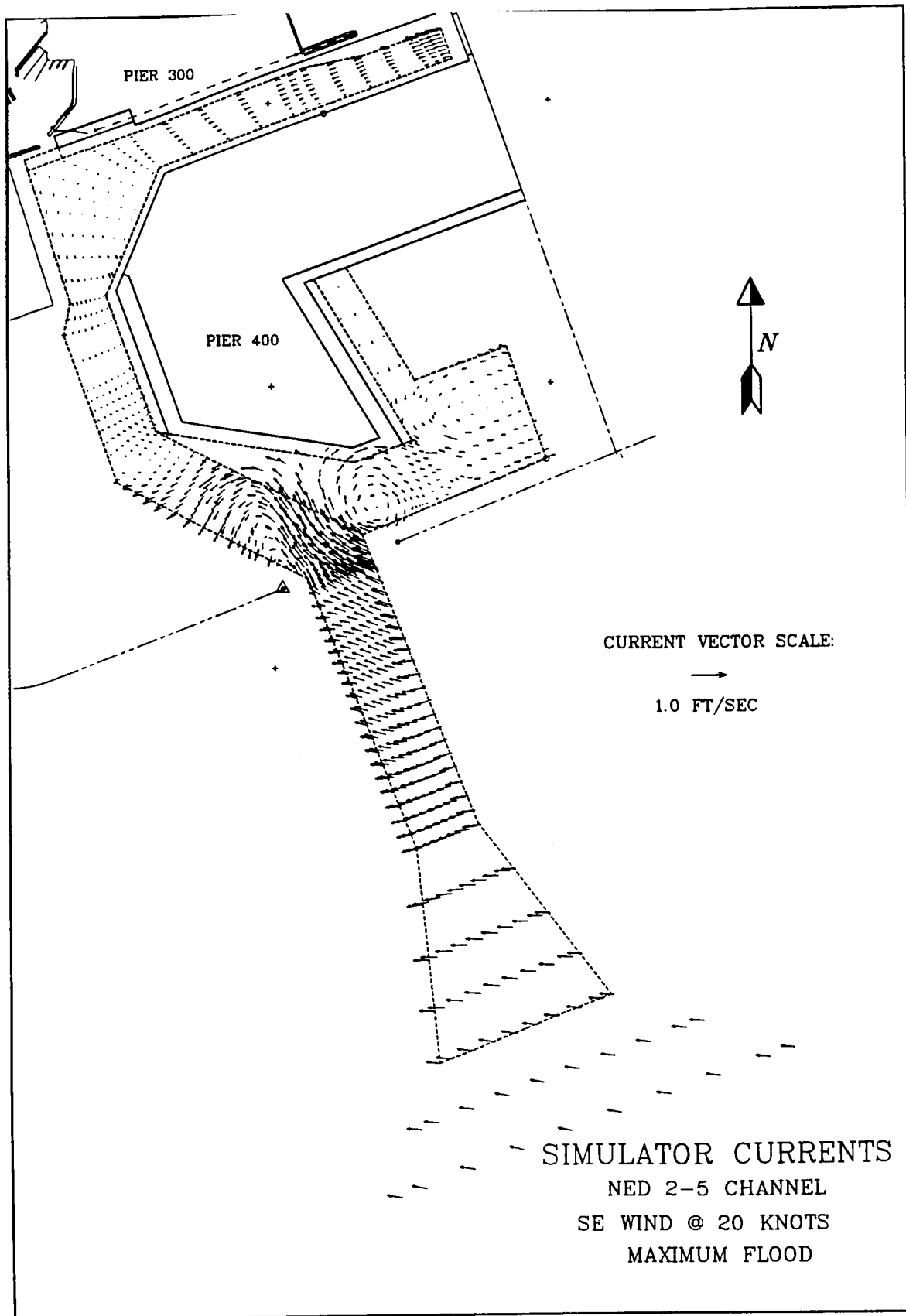
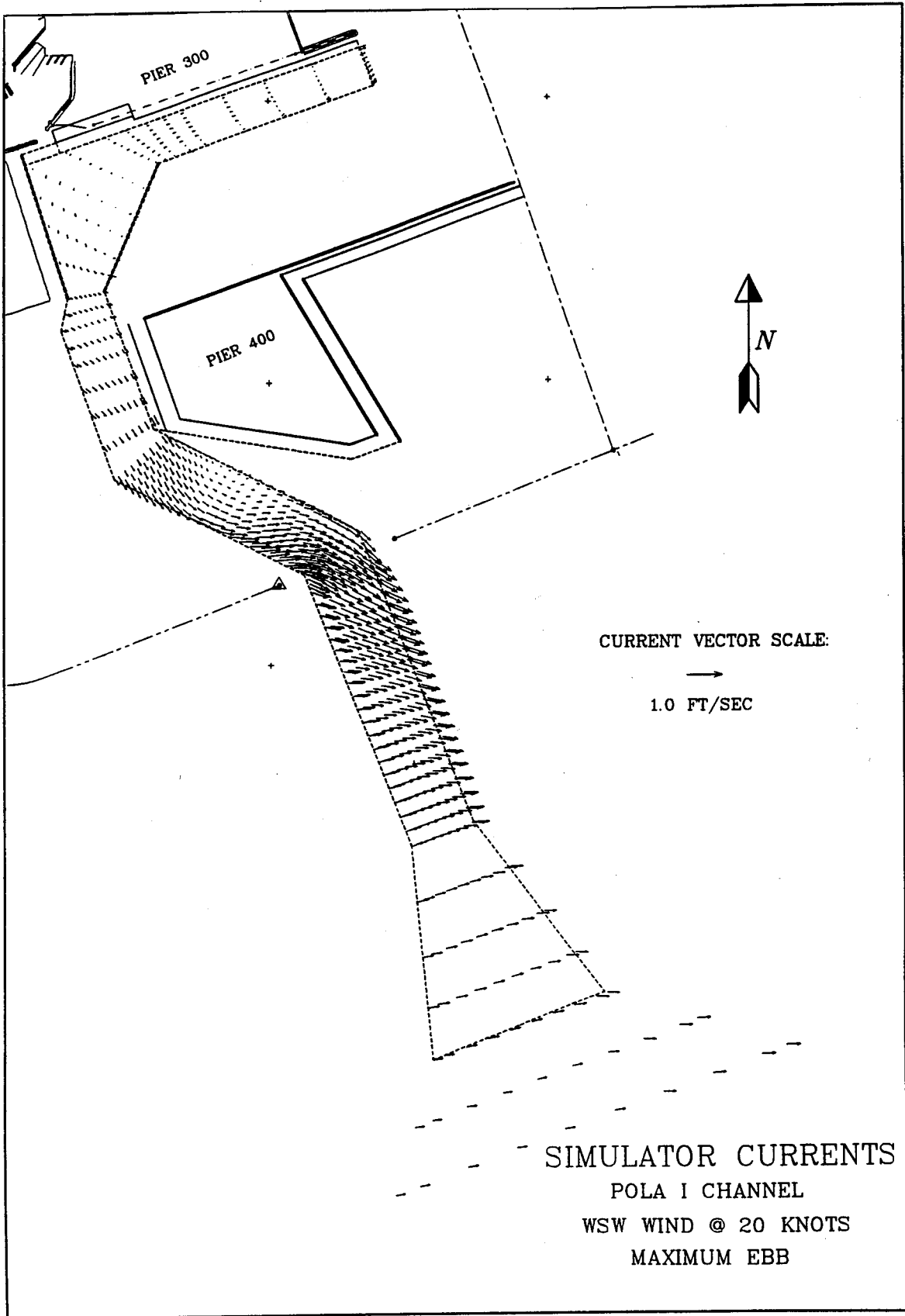

Plate 16



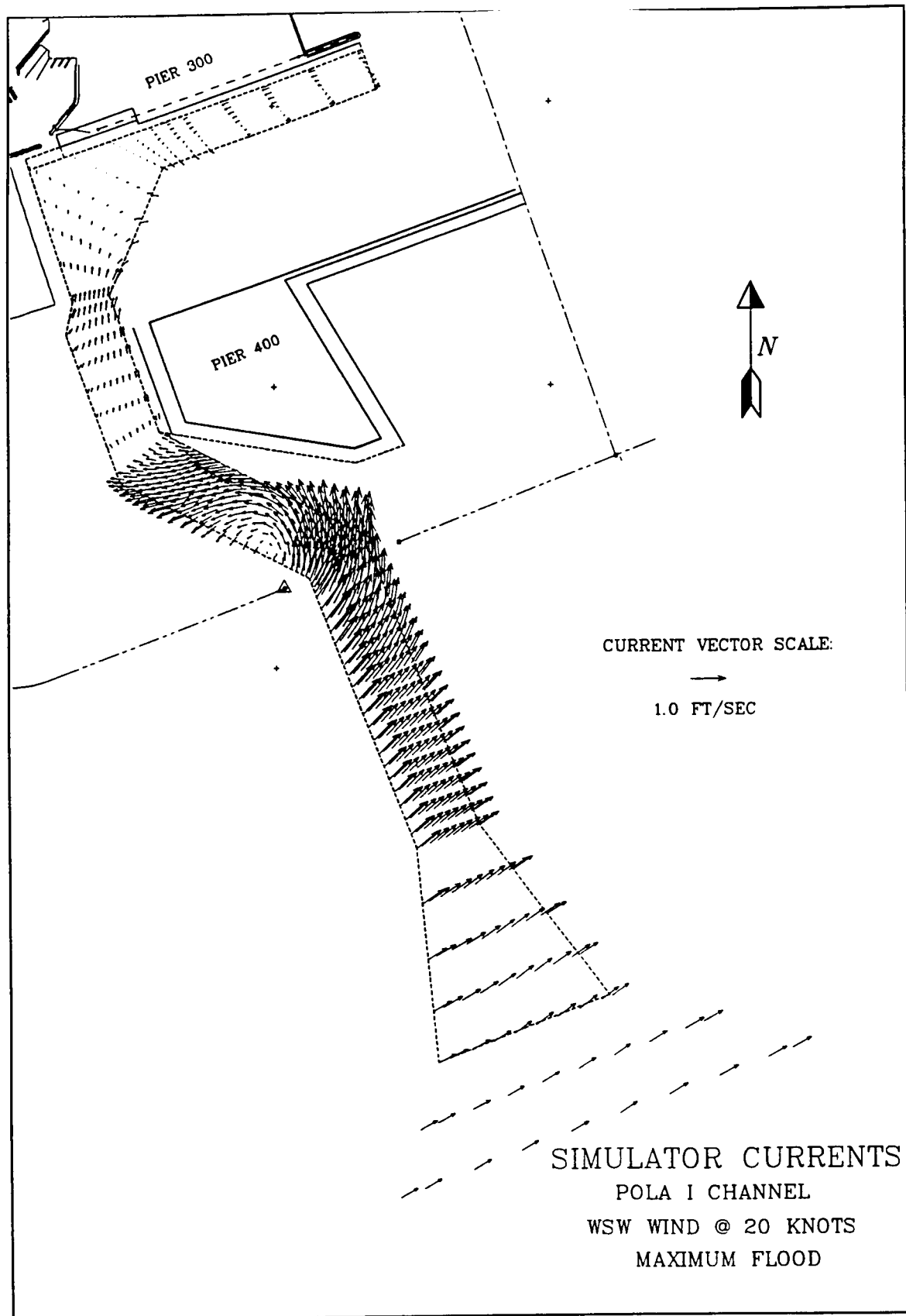
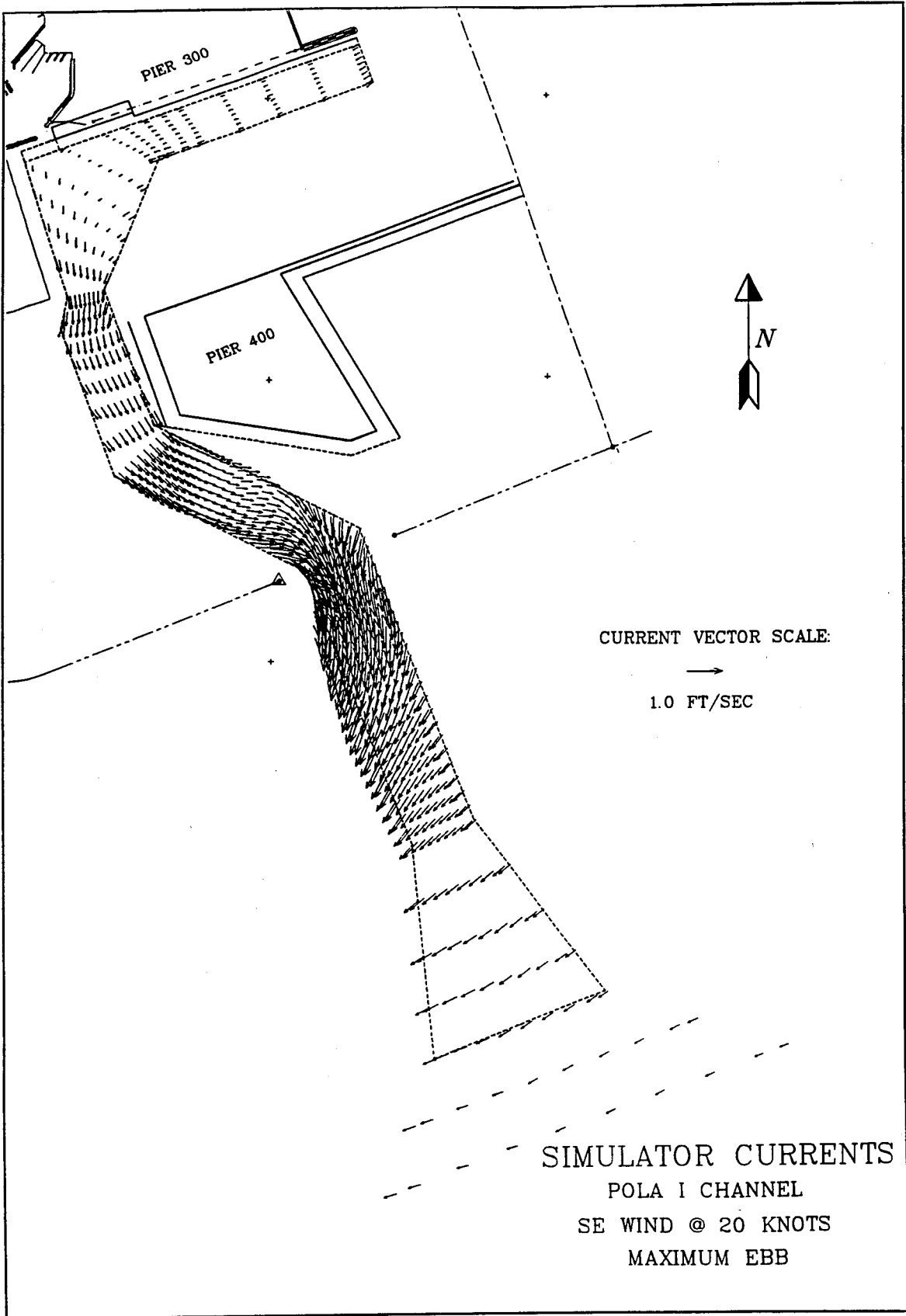

Plate 18



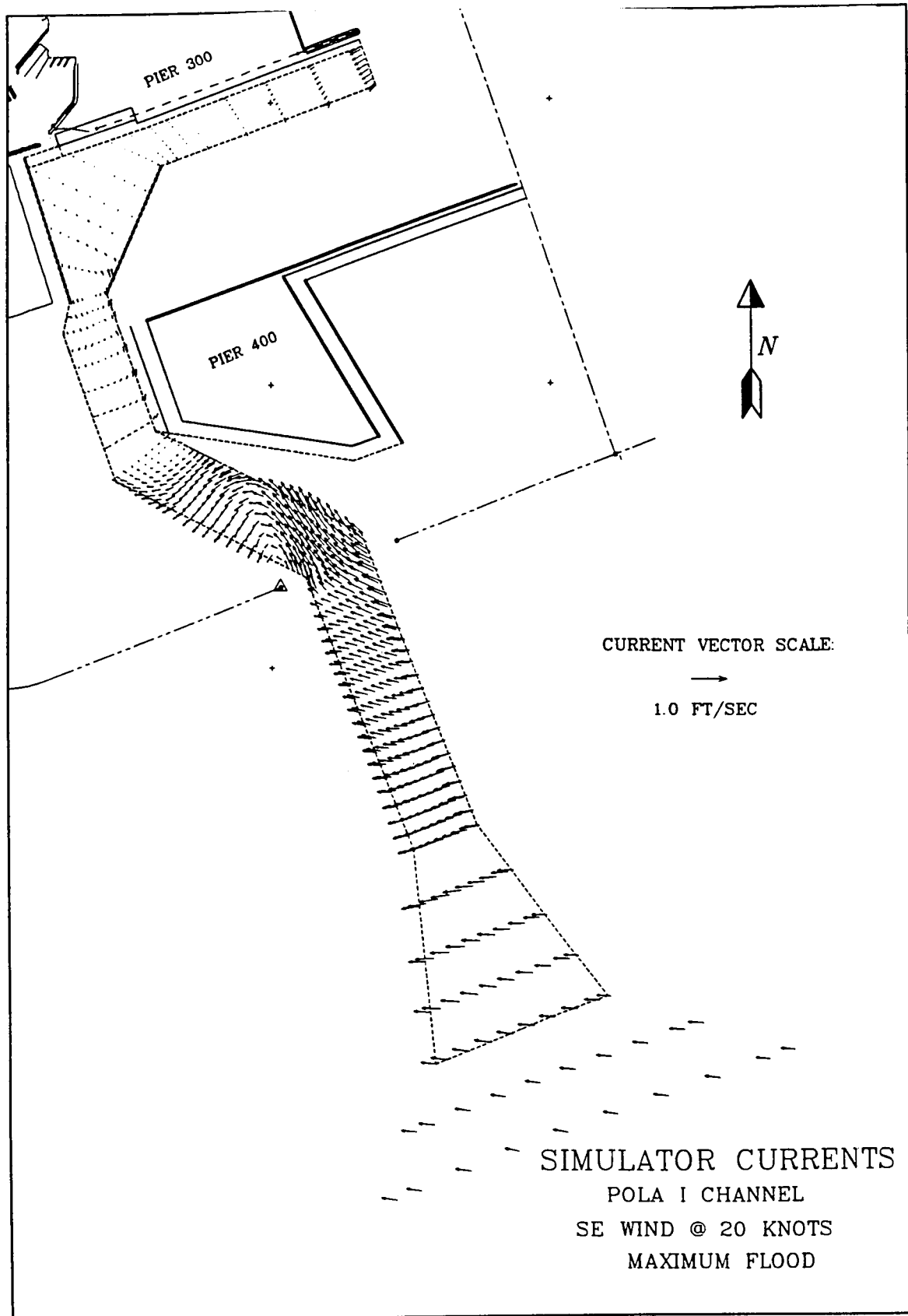
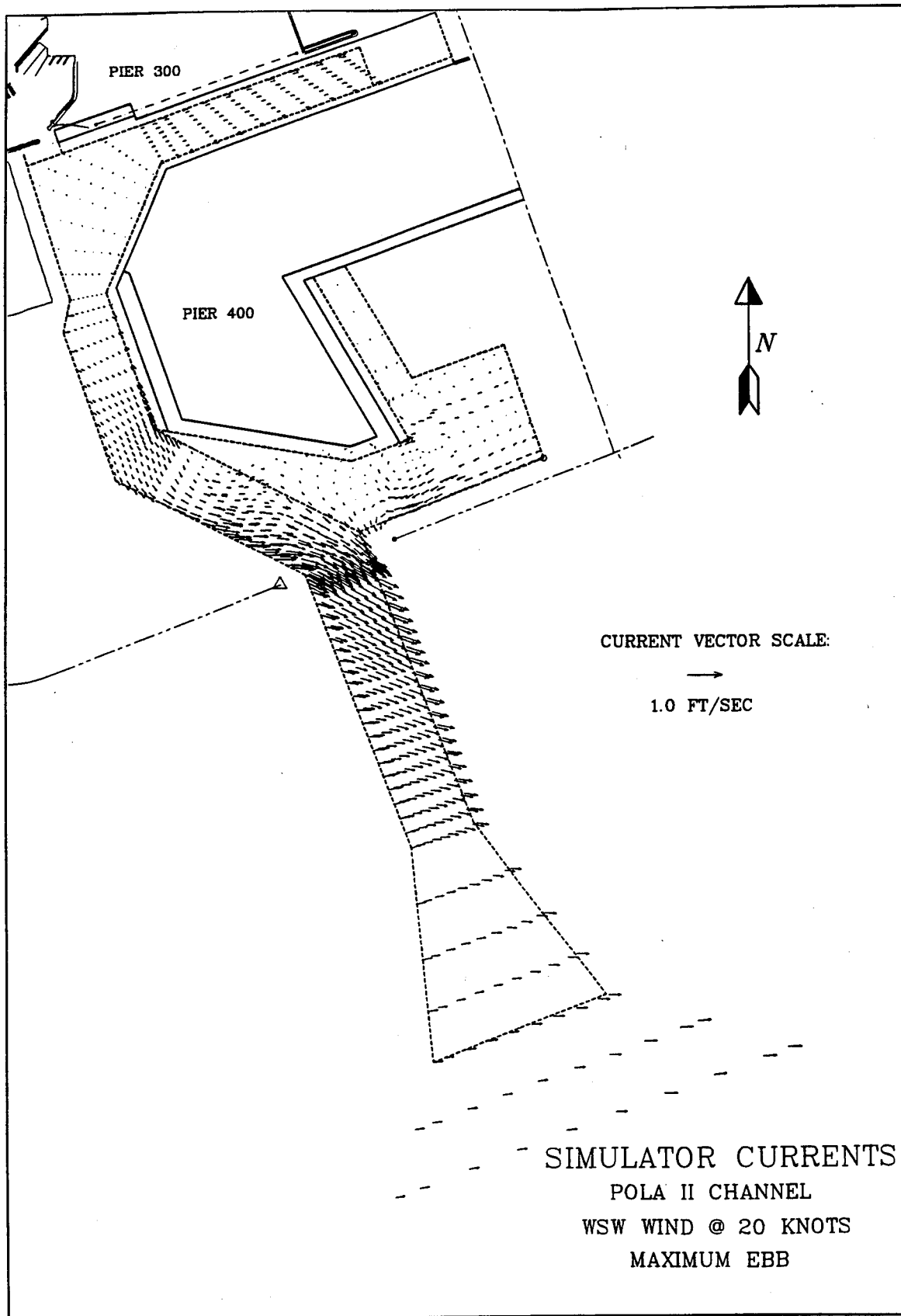

Plate 20



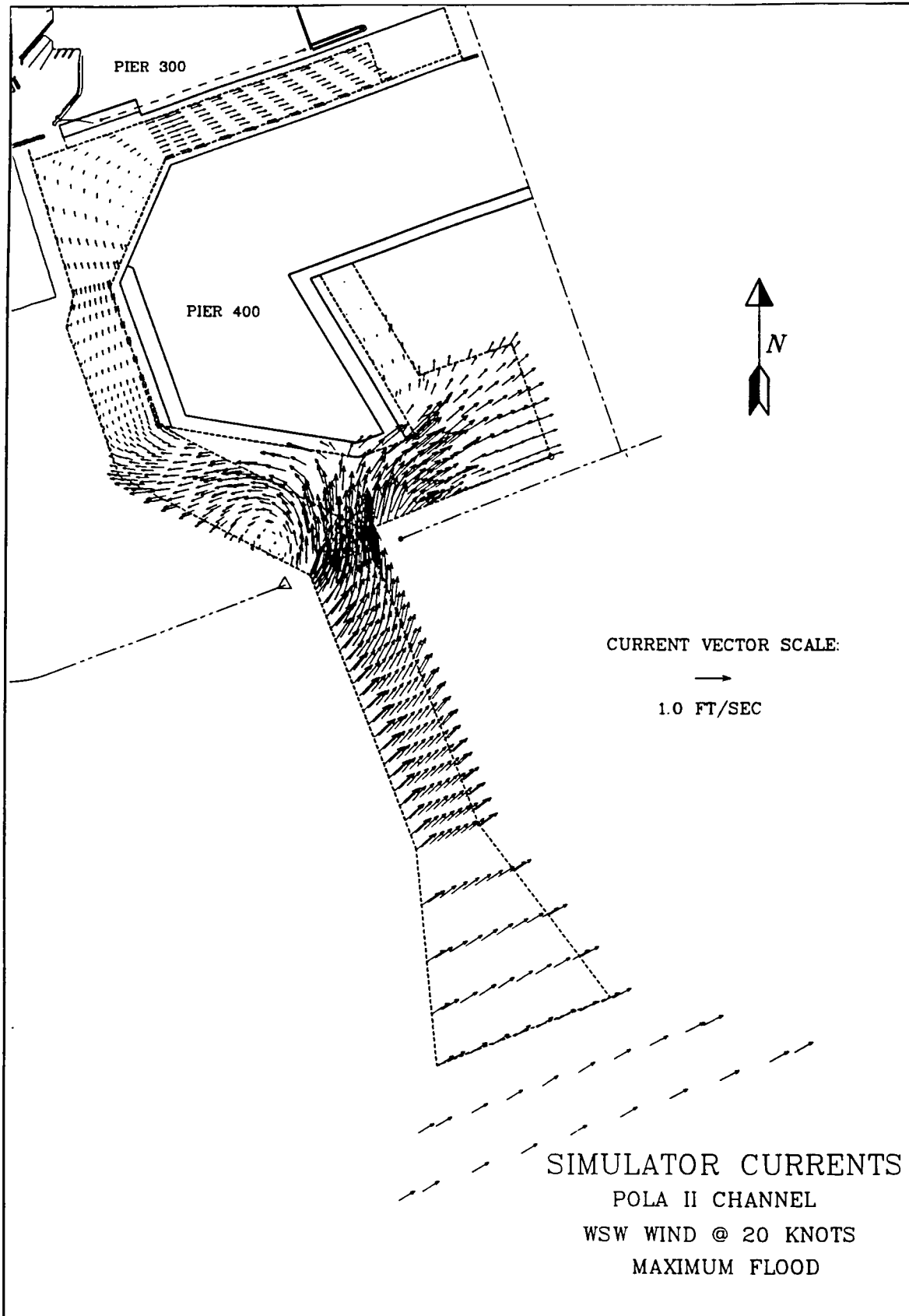
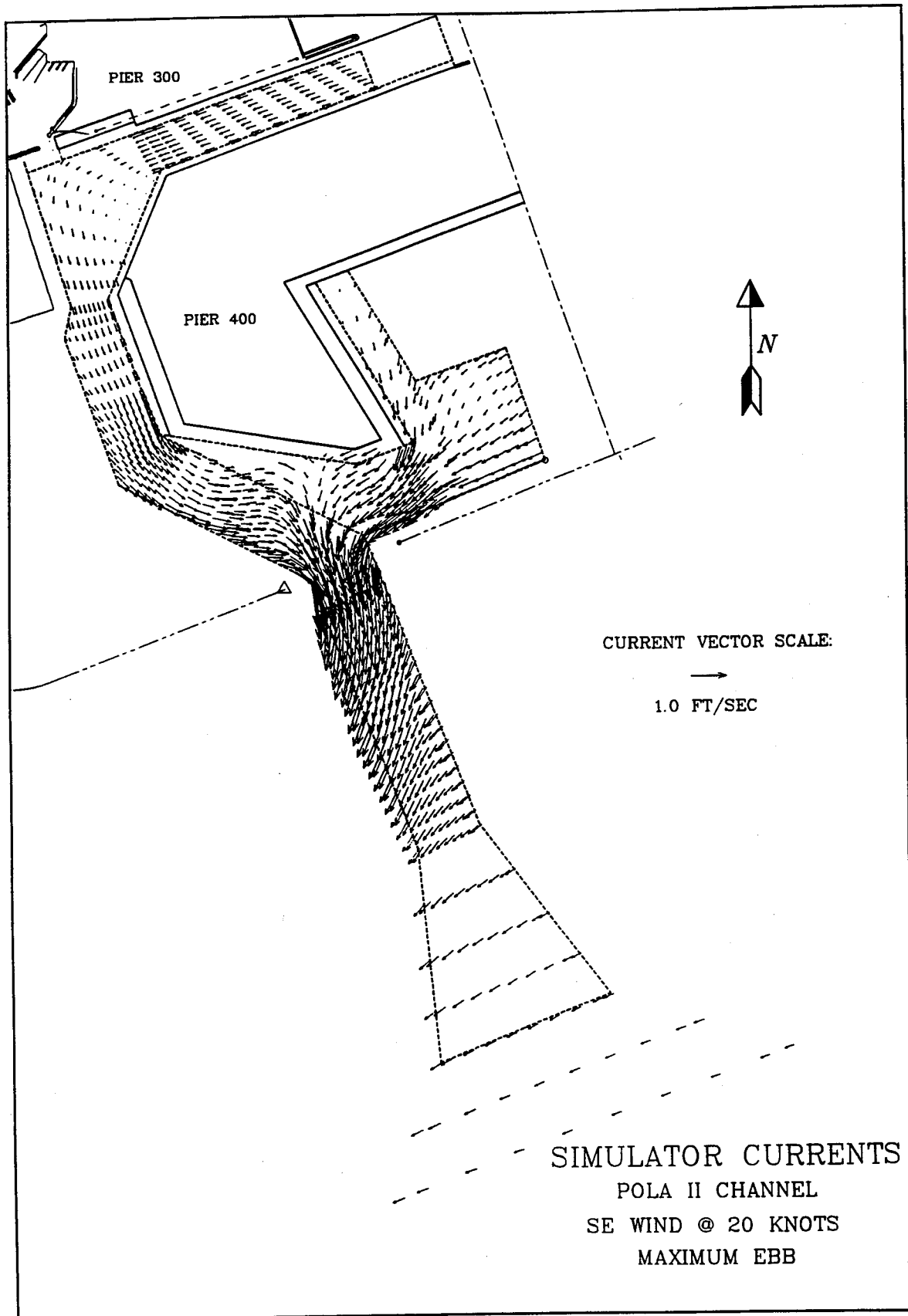

Plate 22



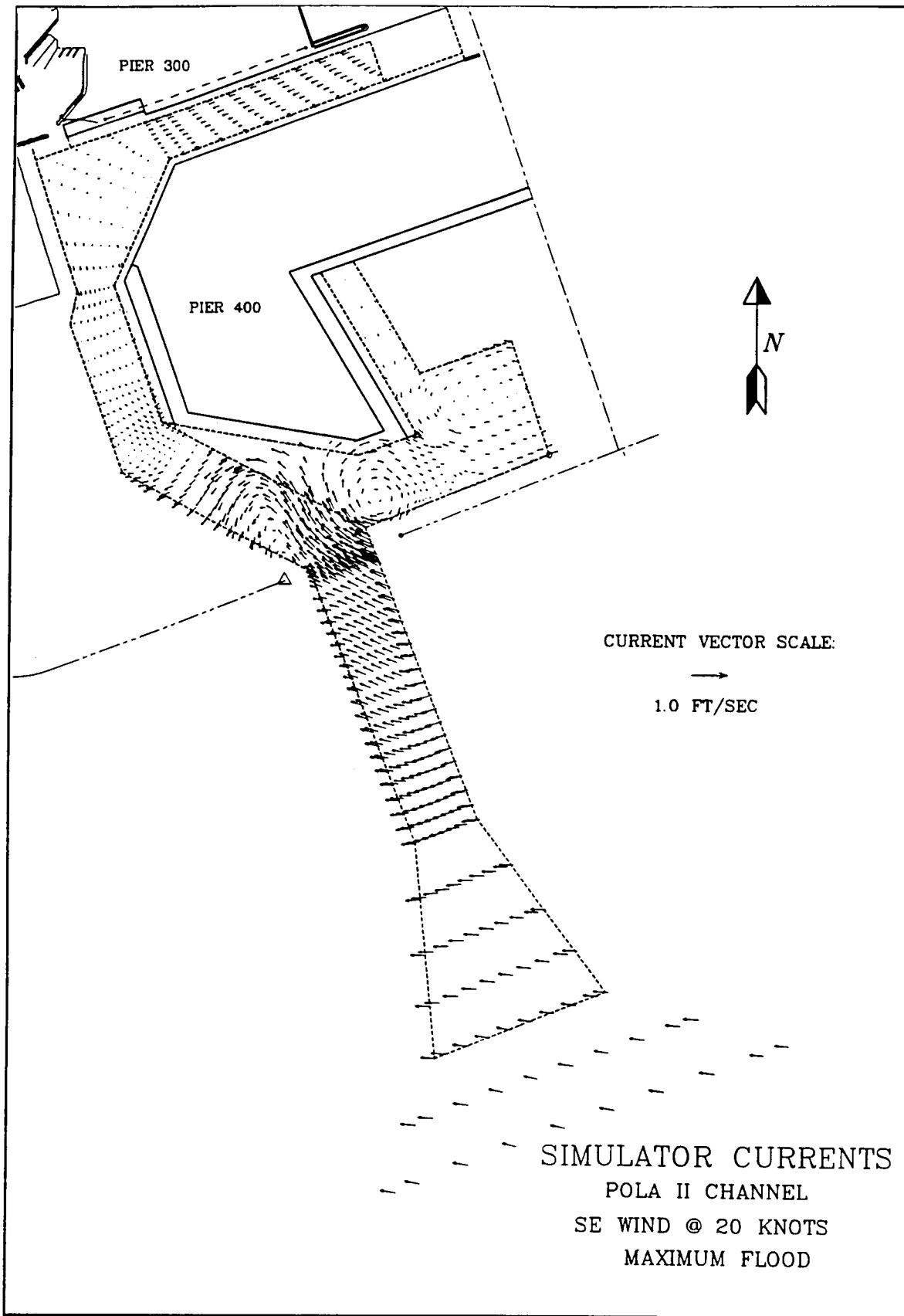
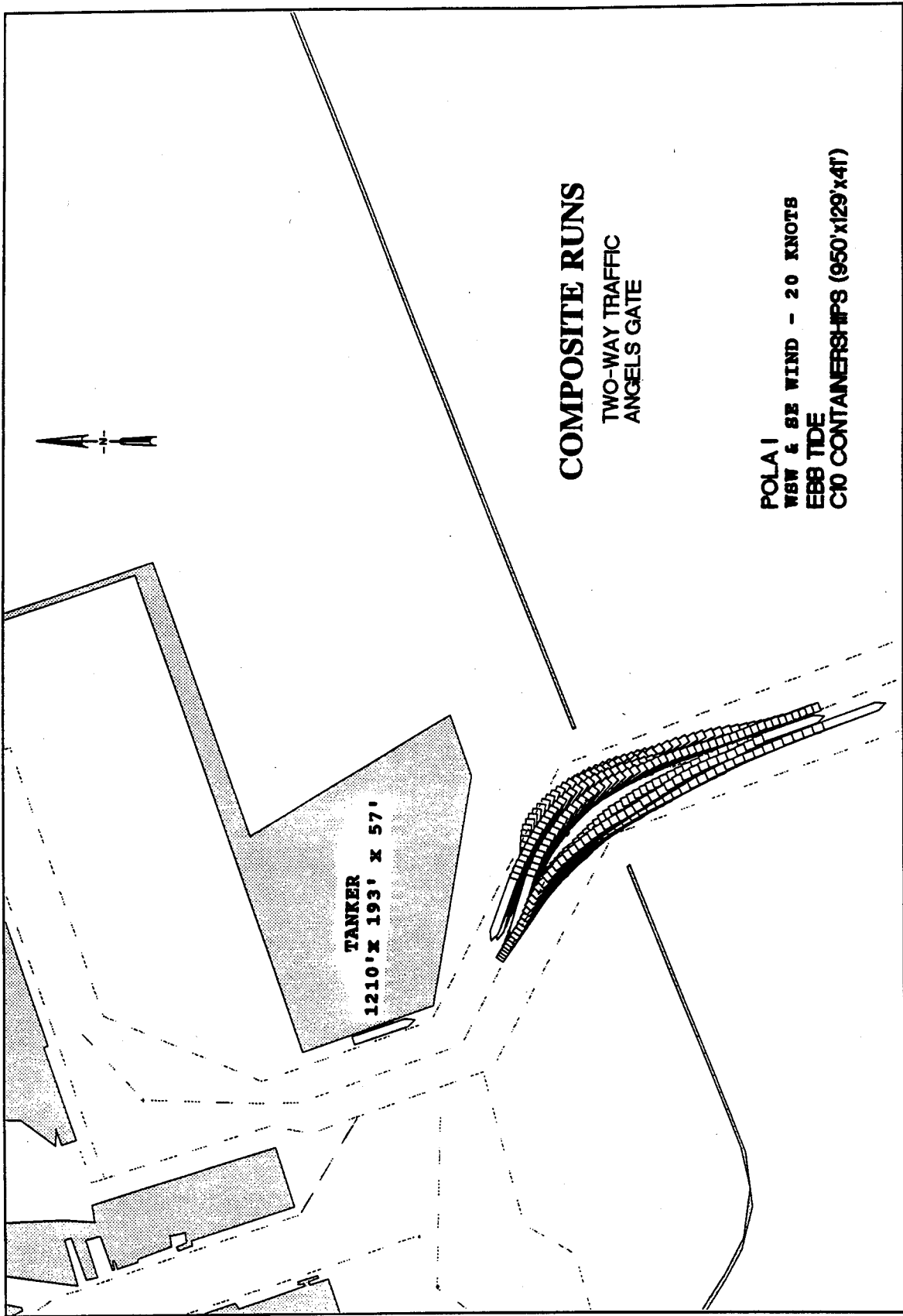

Plate 24



**COMPOSITE RUNS**

TWO-WAY TRAFFIC  
ANGELS GATE

POLA I  
WSW & SE WIND - 20 KNOTS  
EBB TIDE  
C10 CONTAINERSHIPS (950' X 129' X 41')

TANKER  
1210' X 193' X 57'

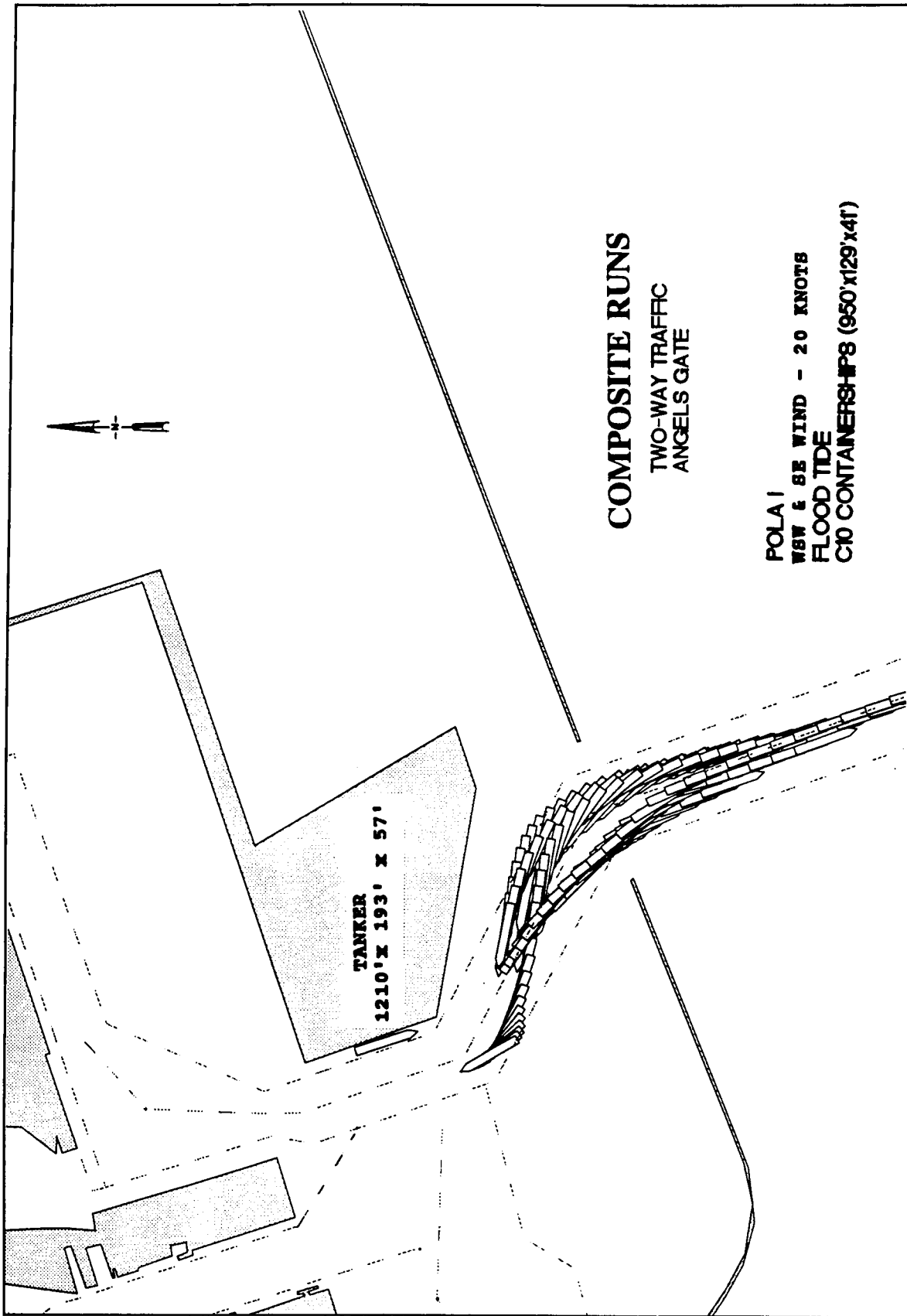
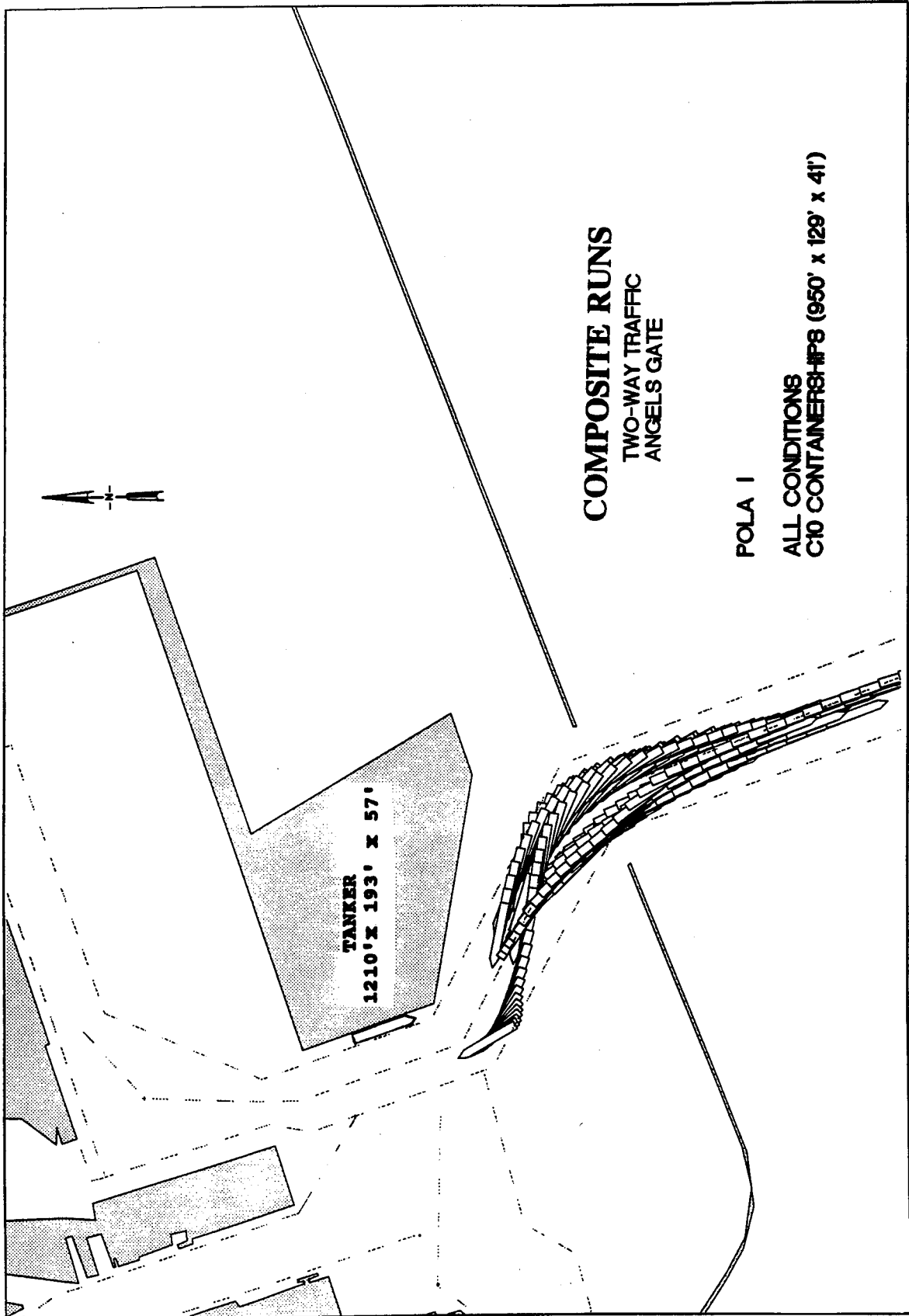

Plate 26



**COMPOSITE RUNS**  
TWO-WAY TRAFFIC  
ANGELS GATE

POLA I

ALL CONDITIONS  
C10 CONTAINERS HP8 (950' x 129' x 41')

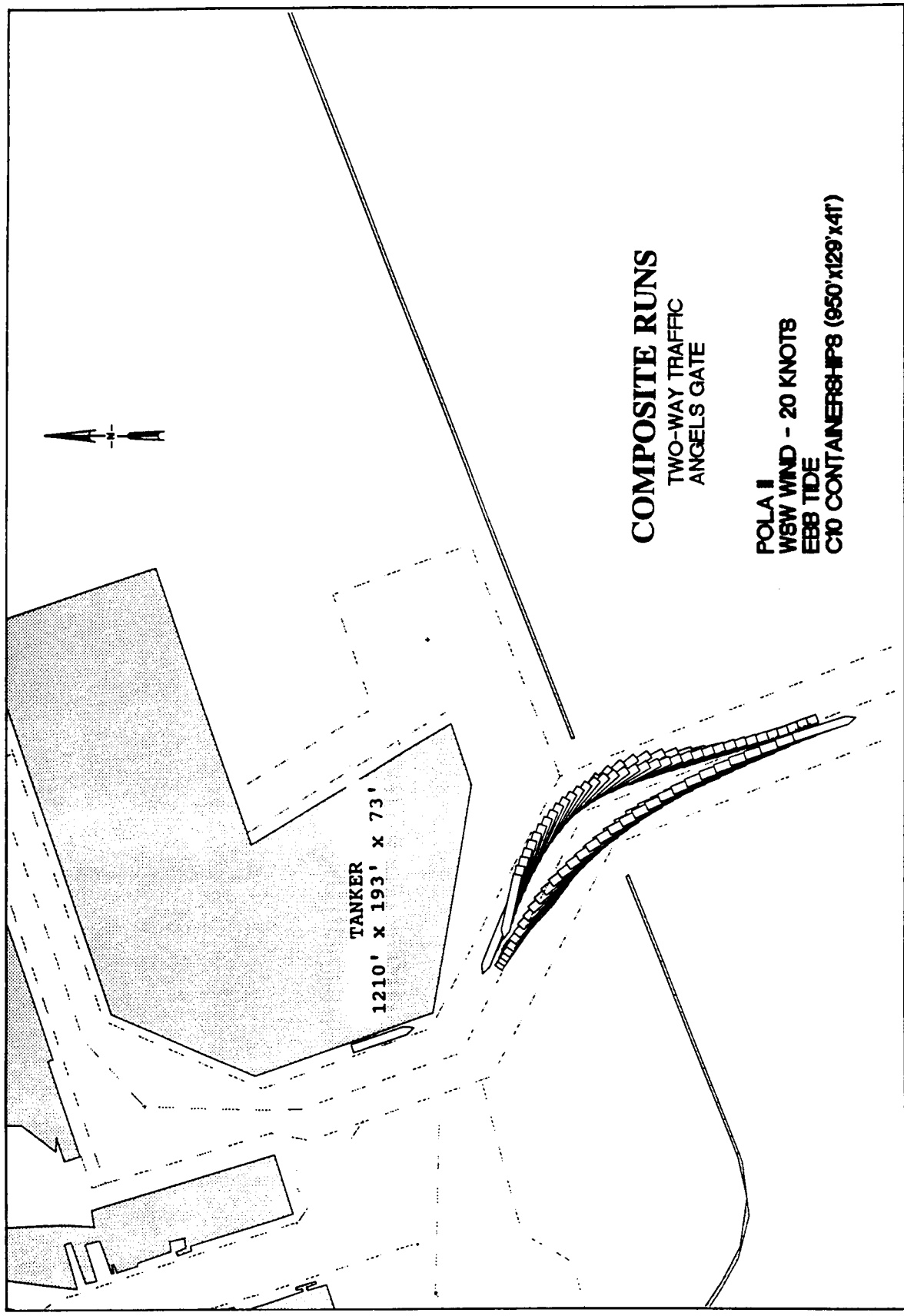
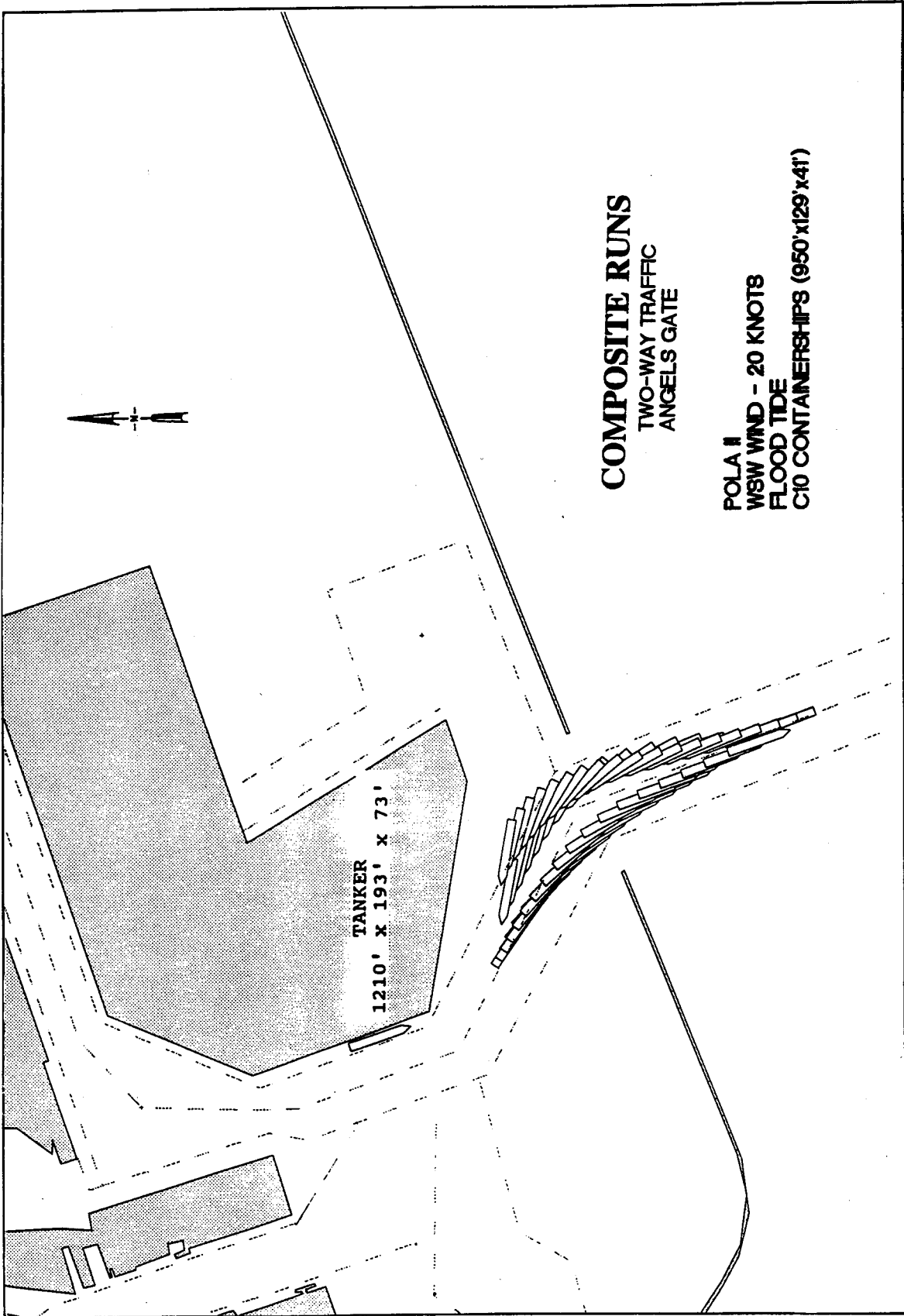

Plate 28



**COMPOSITE RUNS**  
TWO-WAY TRAFFIC  
ANGELS GATE

**POLA II**  
WSW WIND - 20 KNOTS  
FLOOD TIDE  
C10 CONTAINERSHIPS (950'x129'x41')

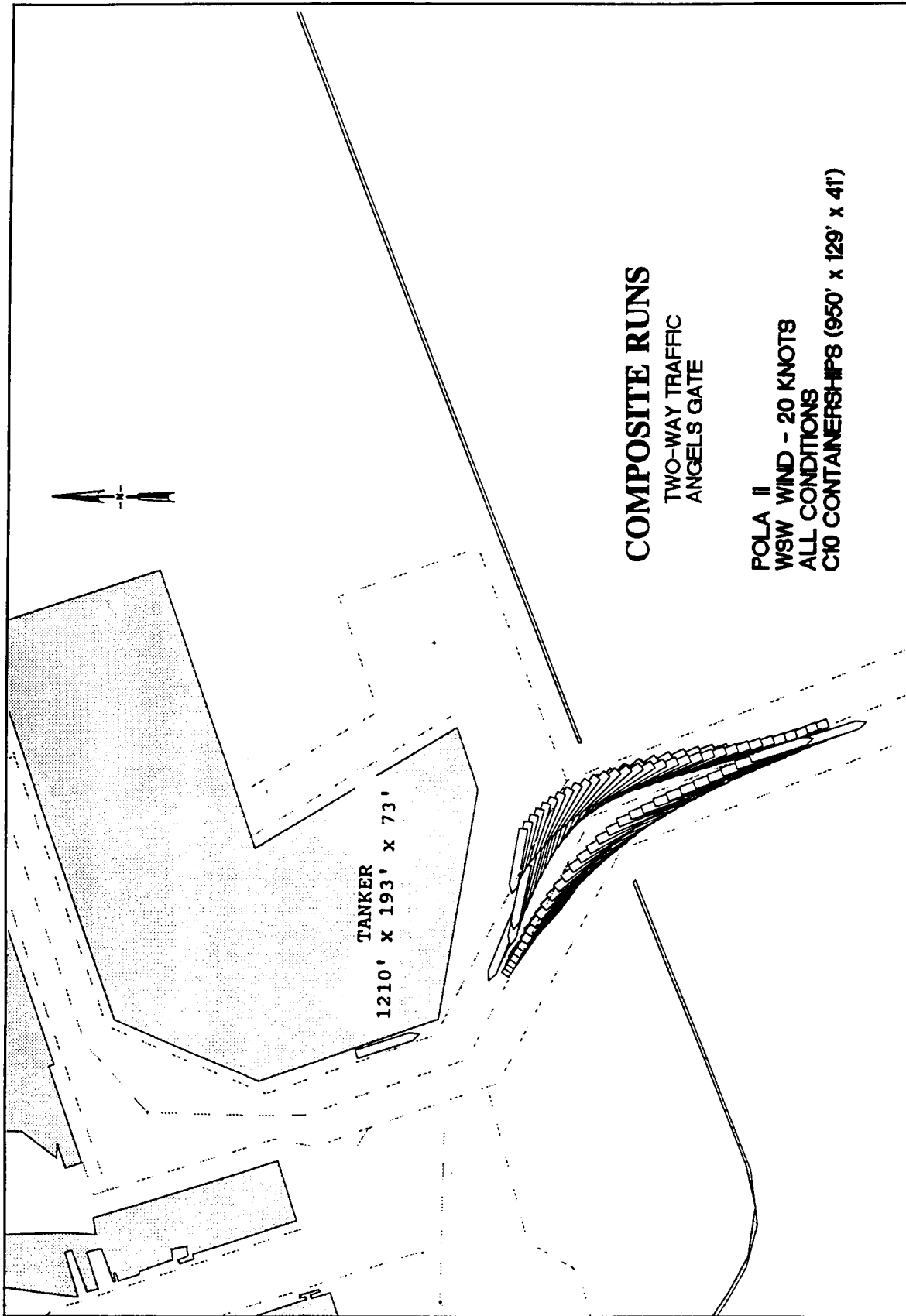
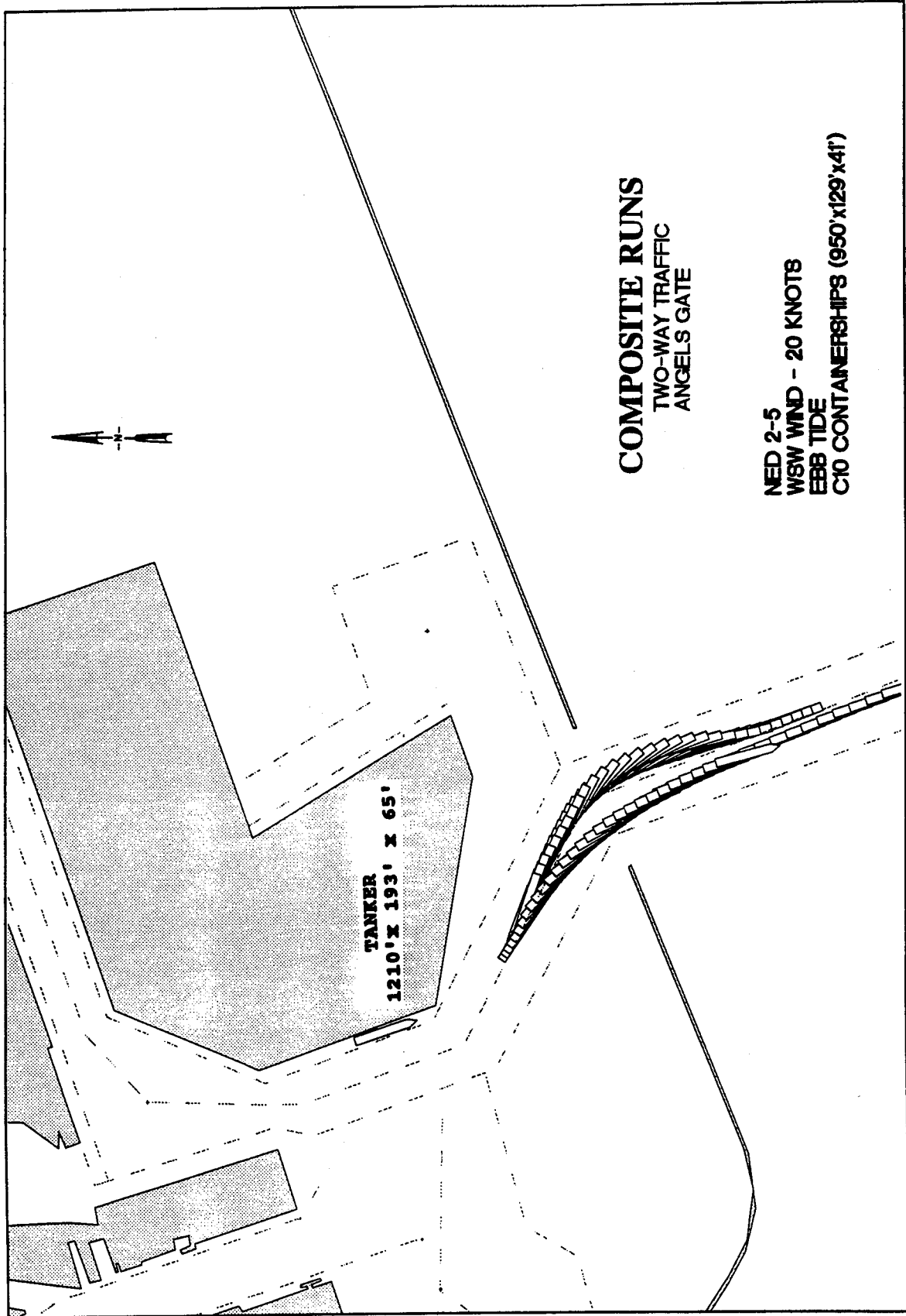

Plate 30



**COMPOSITE RUNS**  
TWO-WAY TRAFFIC  
ANGELS GATE

NED 2-5  
WSW WIND - 20 KNOTS  
EBB TIDE  
C10 CONTAINERSHIPS (950' X 129' X 41')

TANKER  
1210' X 193' X 65'

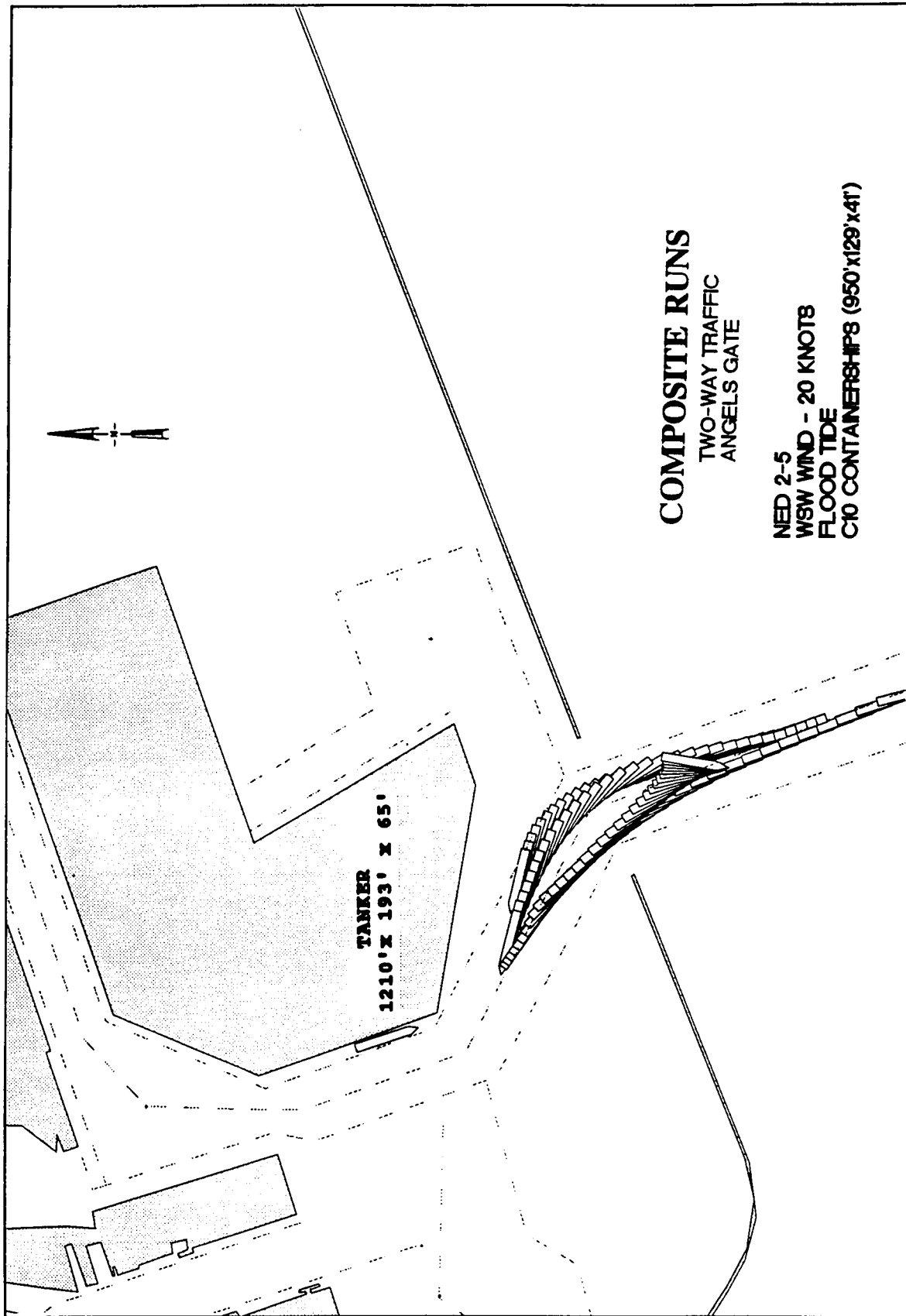
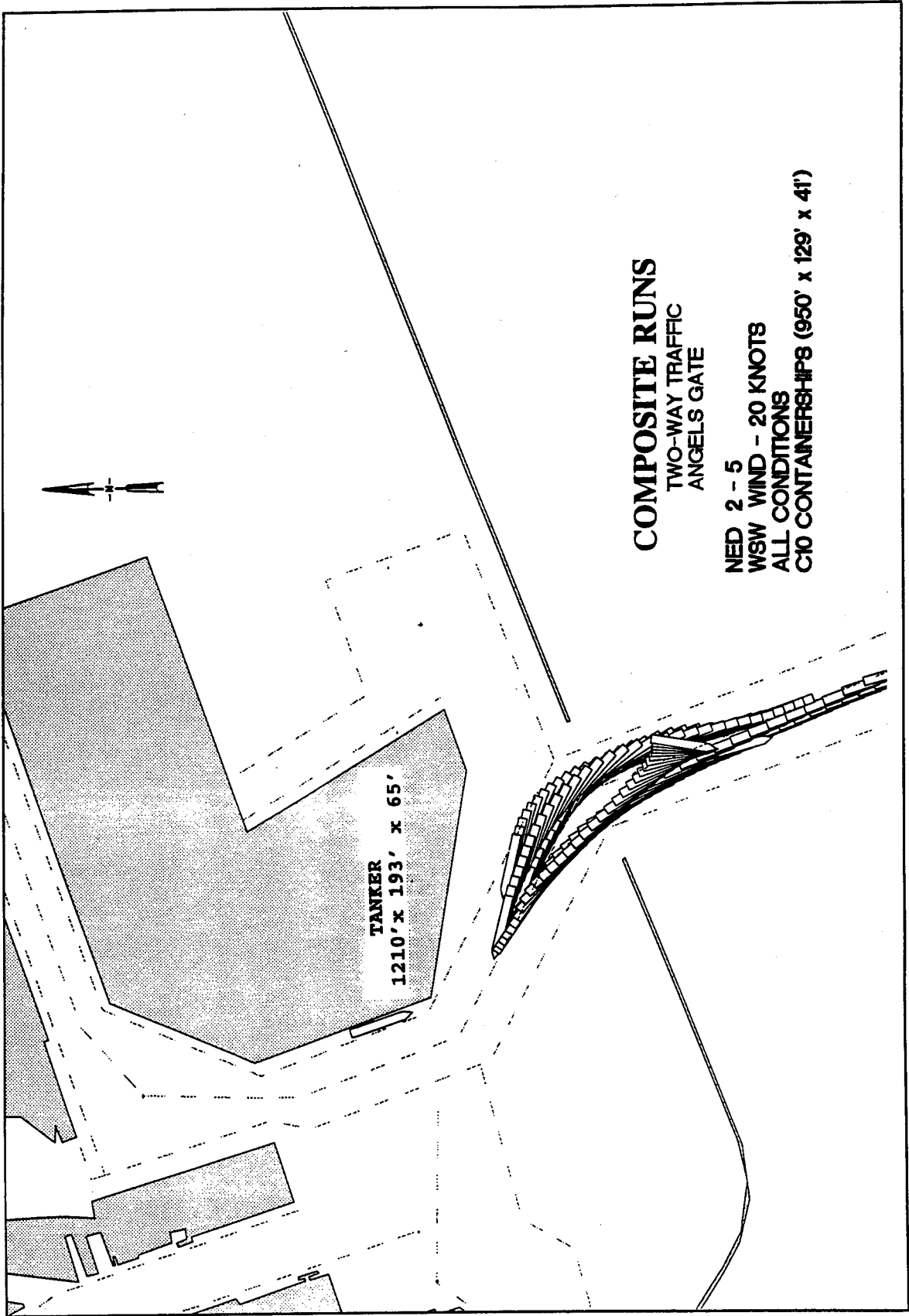

Plate 32



**COMPOSITE RUNS**

TWO-WAY TRAFFIC  
ANGELS GATE

NED 2 - 5

WSW WIND - 20 KNOTS

ALL CONDITIONS

C10 CONTAINERSHIP8 (950' x 129' x 41')

TANKER  
1210' x 193' x 65'

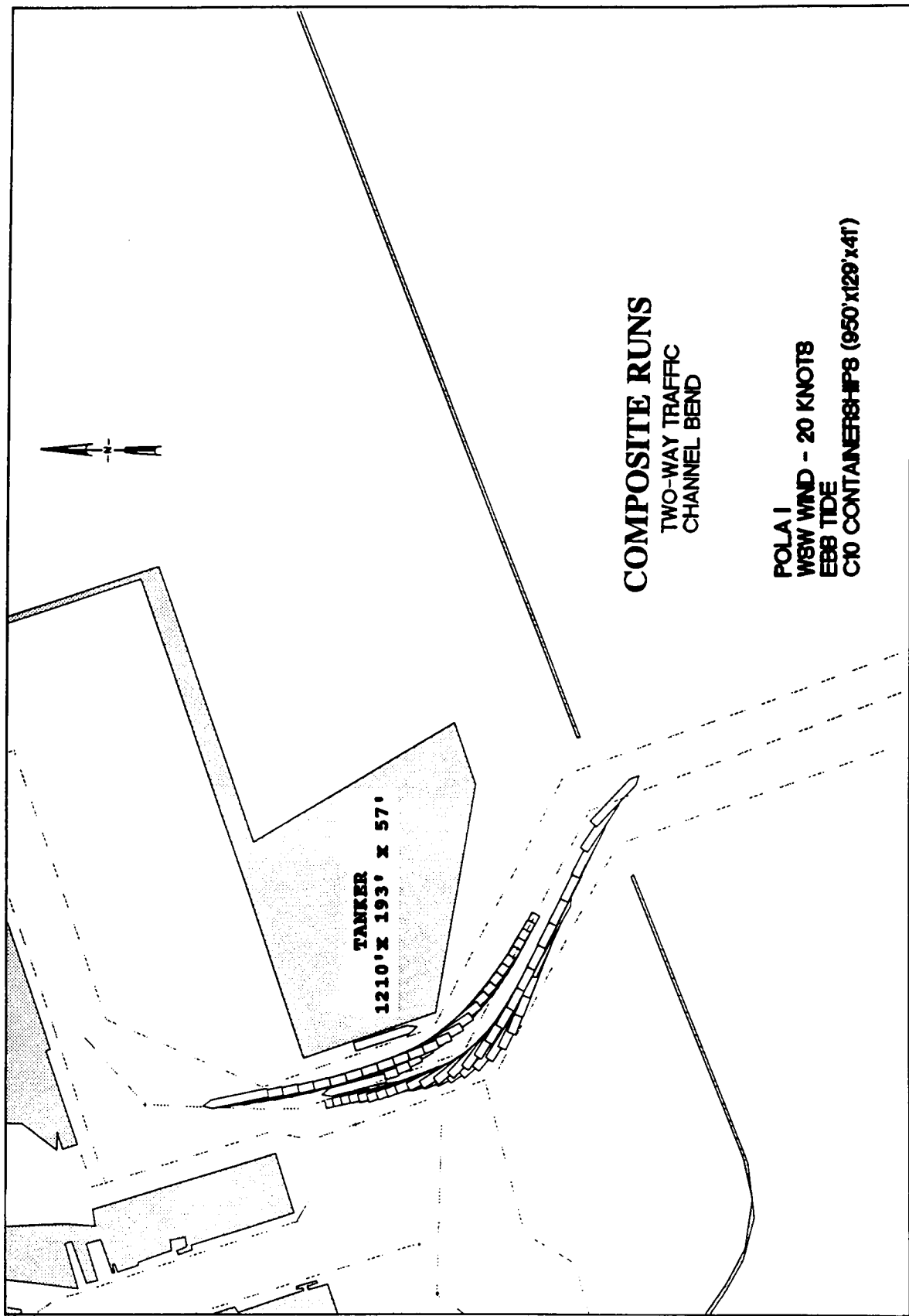

**COMPOSITE RUNS**  
TWO-WAY TRAFFIC  
CHANNEL BEND

**POLA I**  
WSW WIND - 20 KNOTS  
EBB TIDE  
C10 CONTAINERSHP8 (950'X129'X41')

**TANKER**  
**1210' X 193' X 57'**

Plate 34

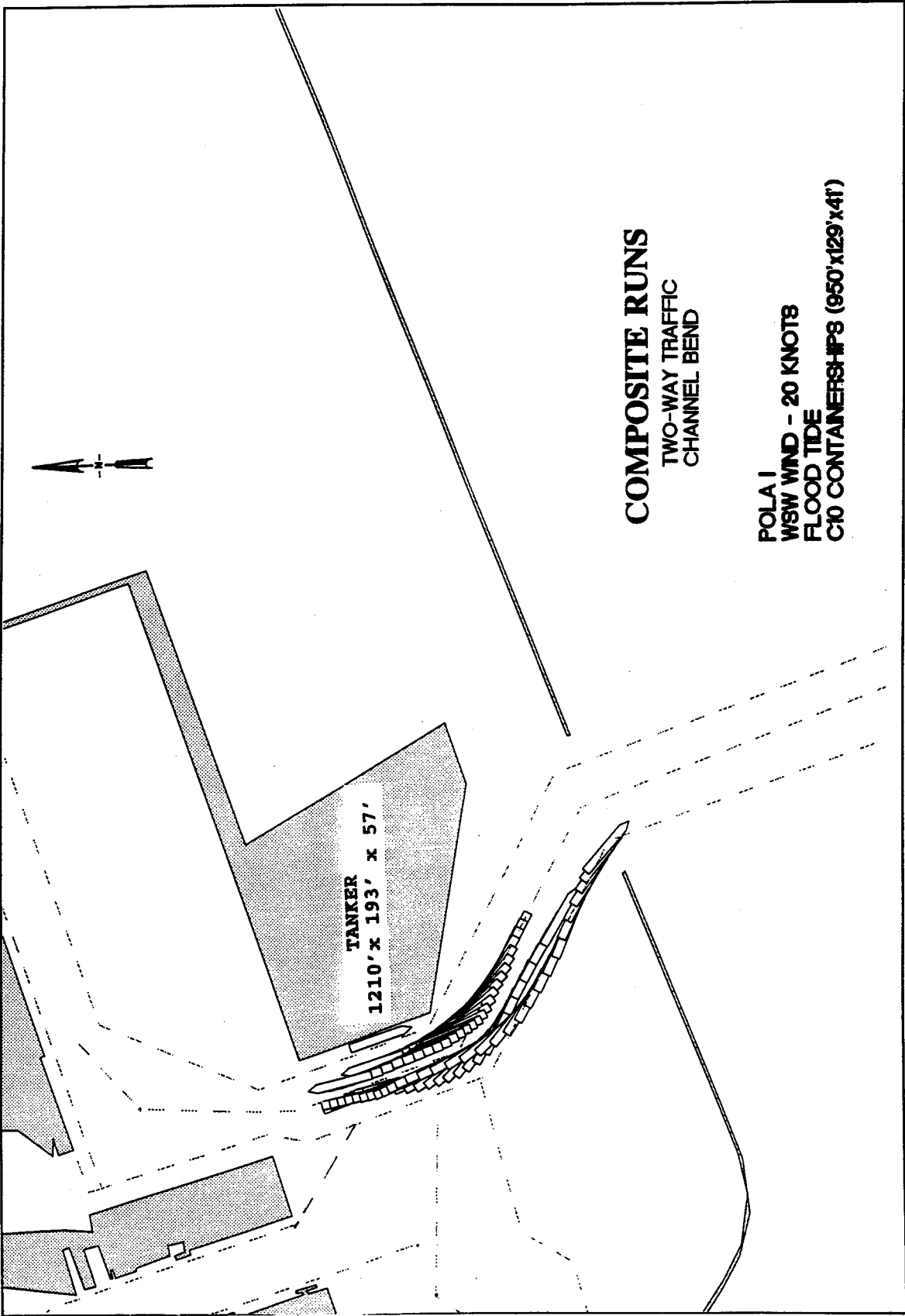

**COMPOSITE RUNS**

TWO-WAY TRAFFIC  
CHANNEL BEND

POLA I  
WSW WIND - 20 KNOTS  
FLOOD TIDE  
C10 CONTAINERS#P8 (950'x129'x41')

TANKER  
1210' x 193' x 57'

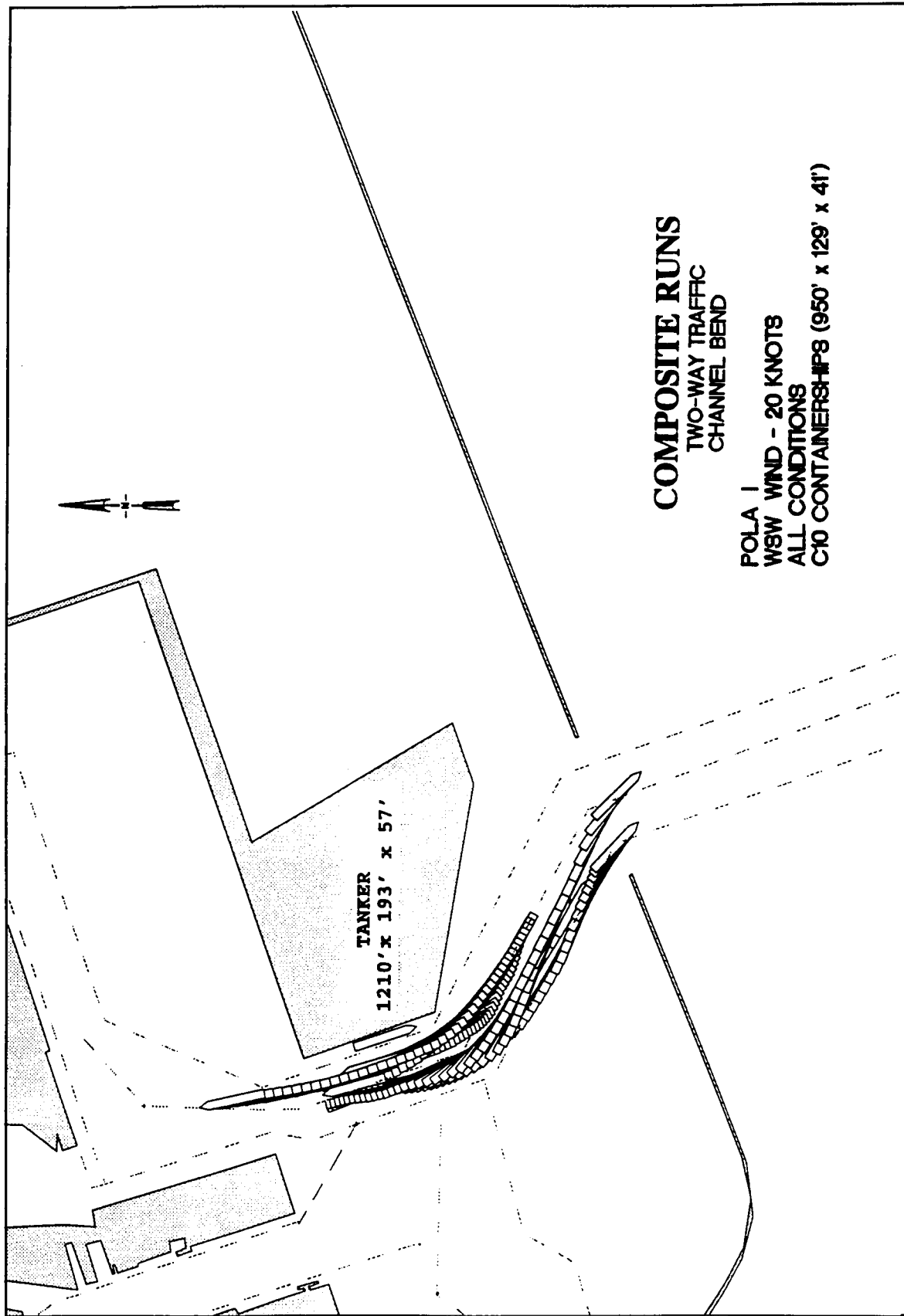
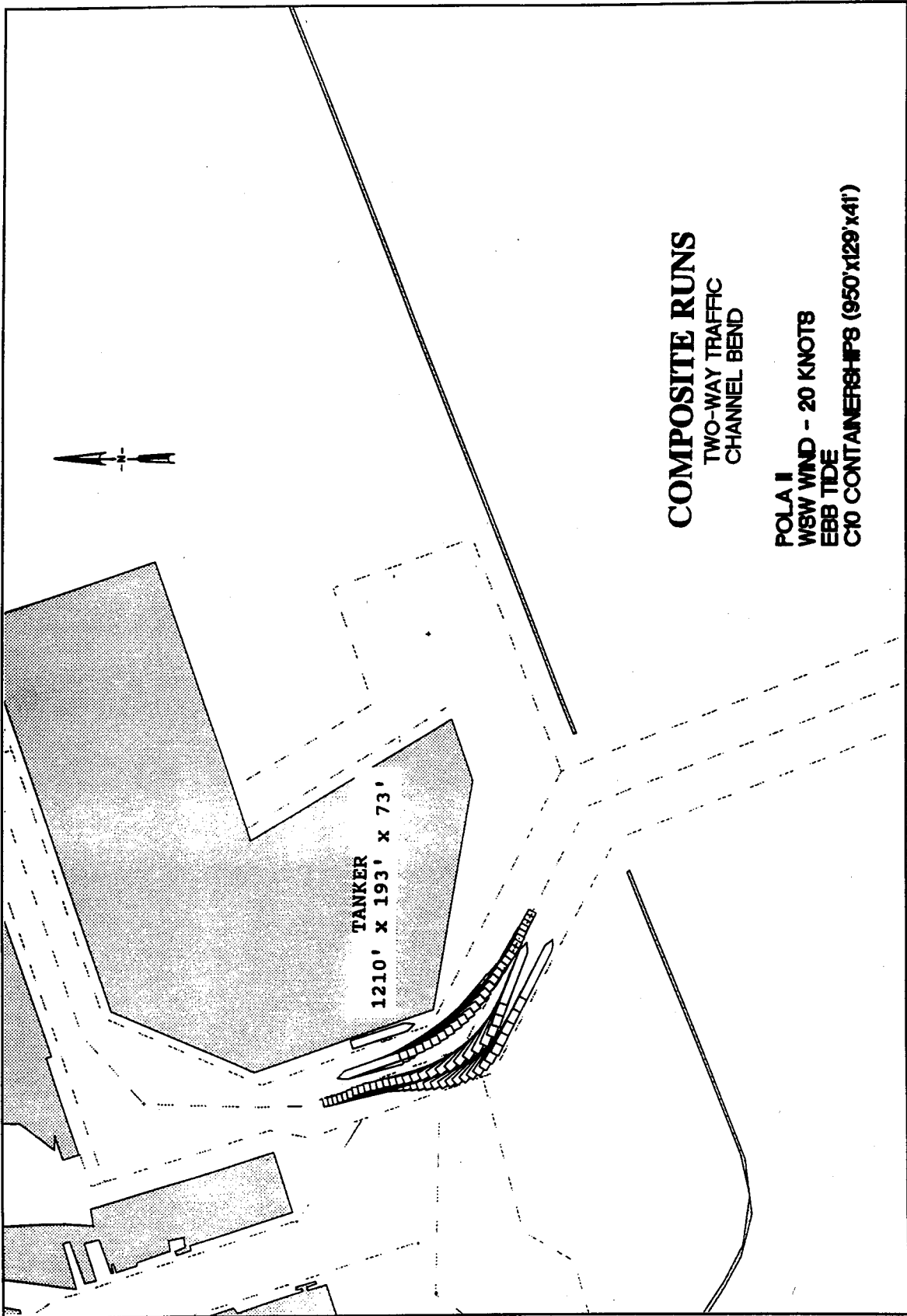

Plate 36



**COMPOSITE RUNS**  
TWO-WAY TRAFFIC  
CHANNEL BEND

**POLA II**  
**WSW WIND - 20 KNOTS**  
**EBB TIDE**  
**C10 CONTAINERSHP8 (950'x129'x41')**

TANKER  
1210' x 193' x 73'

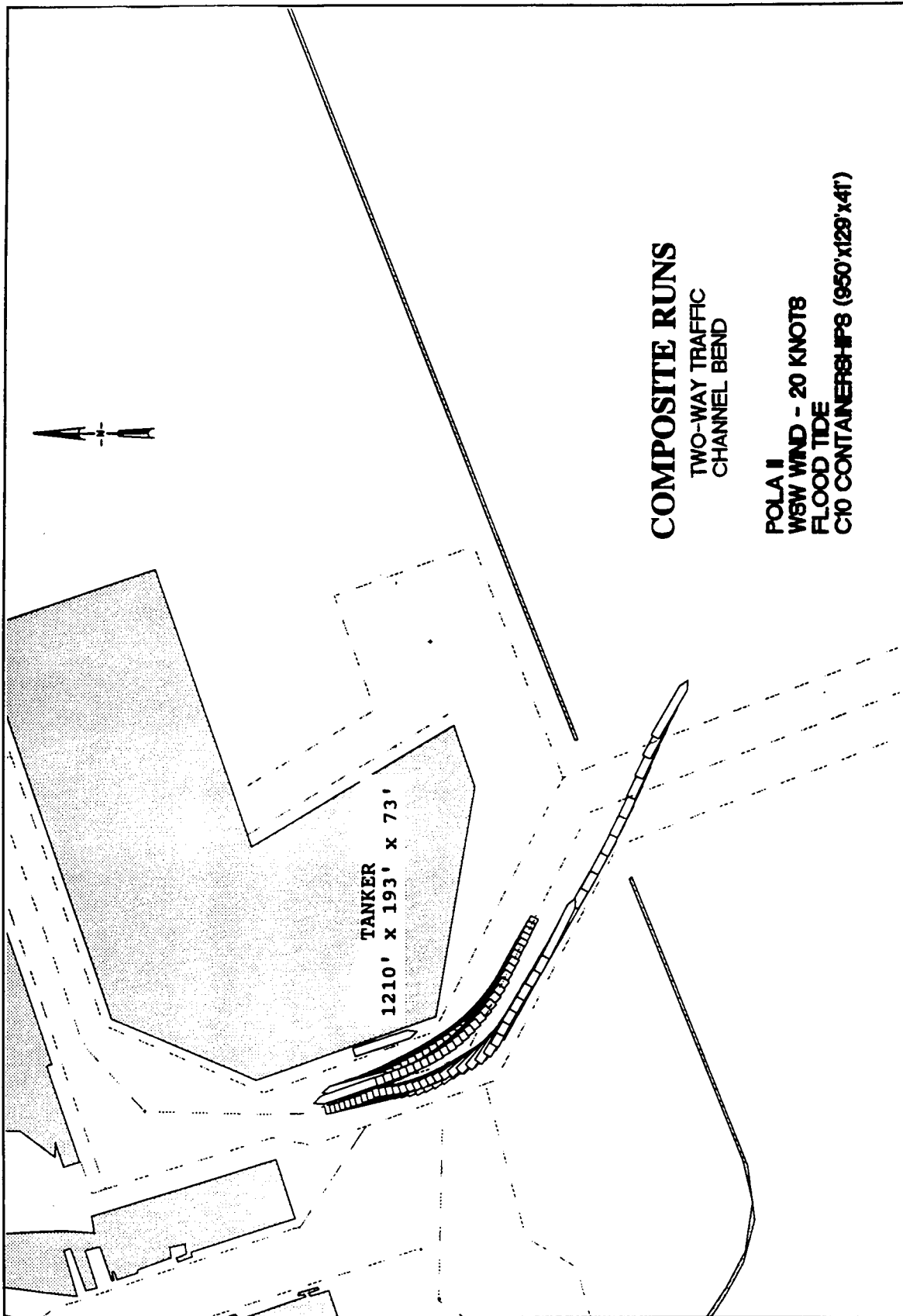
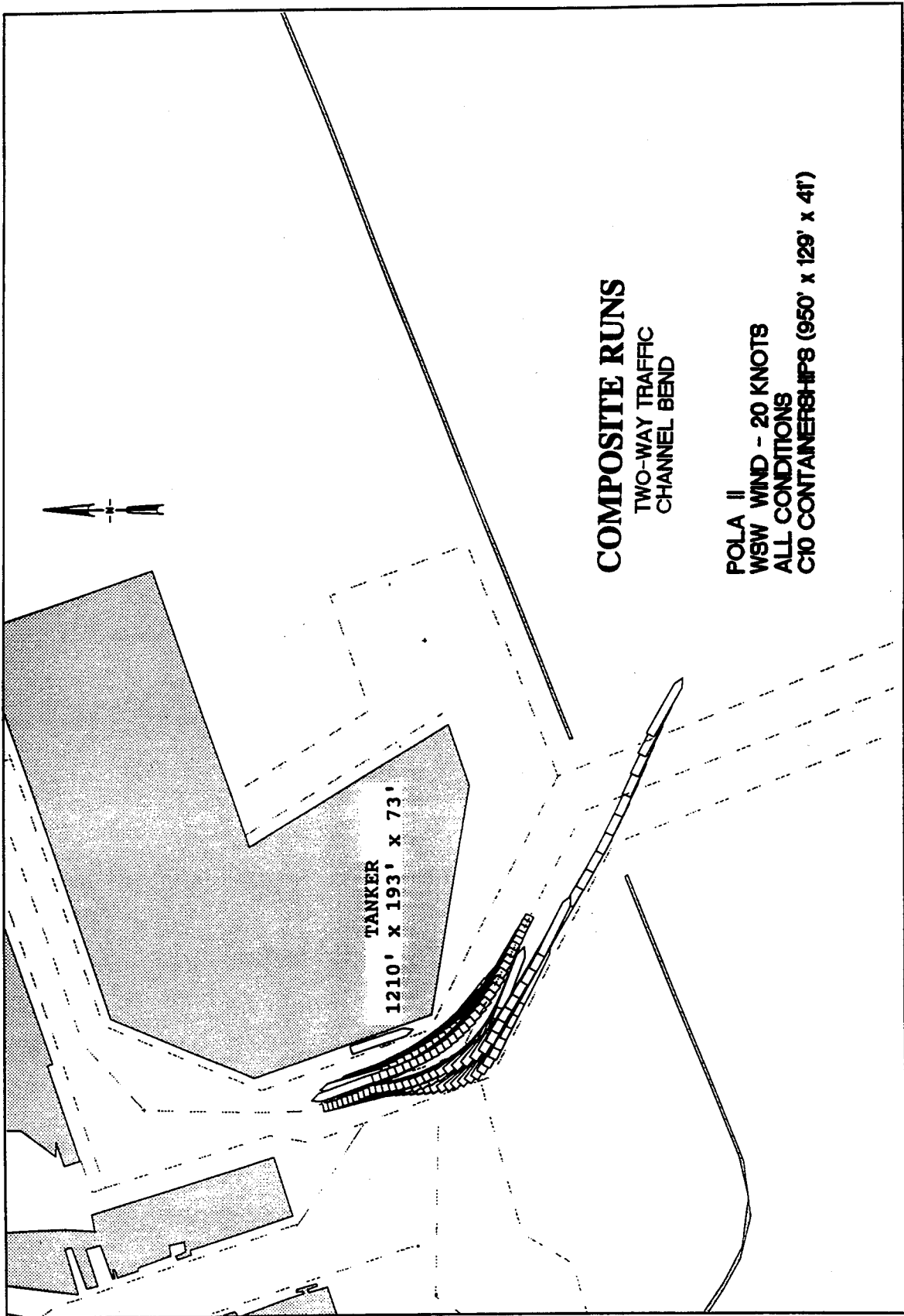

Plate 38



**COMPOSITE RUNS**

TWO-WAY TRAFFIC  
CHANNEL BEND

POLA II  
WSW WIND - 20 KNOTS  
ALL CONDITIONS  
C10 CONTAINERS #P8 (950' x 129' x 41')

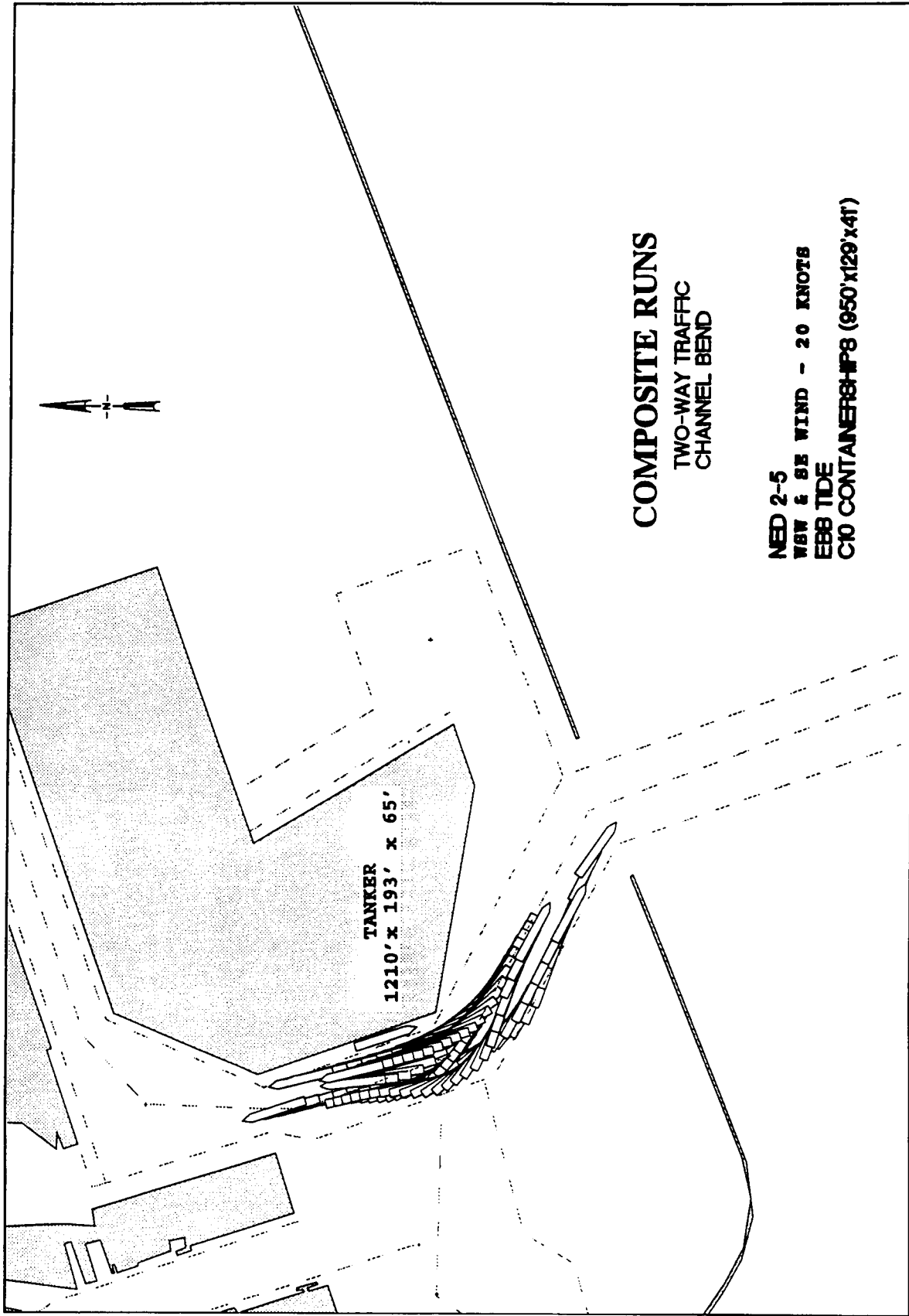

**COMPOSITE RUNS**

**TWO-WAY TRAFFIC  
CHANNEL BEND**

**NEED 2-5  
WBW & SB WIND - 20 KNOTS  
EBB TIDE  
C10 CONTAINER#P8 (950'x129'x41')**

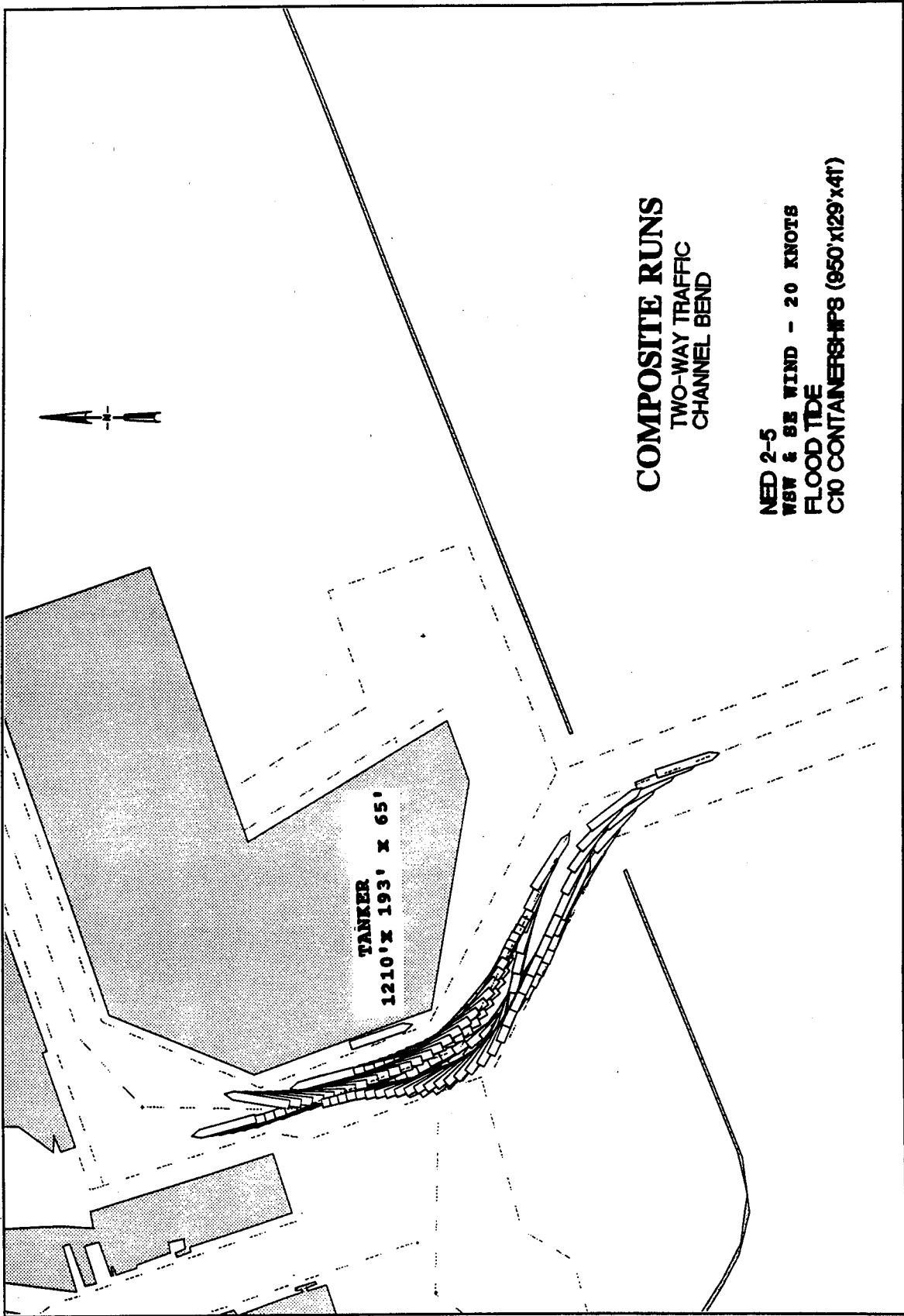

**COMPOSITE RUNS**

TWO-WAY TRAFFIC  
CHANNEL BEND

NEED 2-5  
WSW & SE WIND - 20 KNOTS  
FLOOD TIDE  
C10 CONTAINERS#P8 (950'X129'X41)

TANKER  
1210' X 193' X 65'

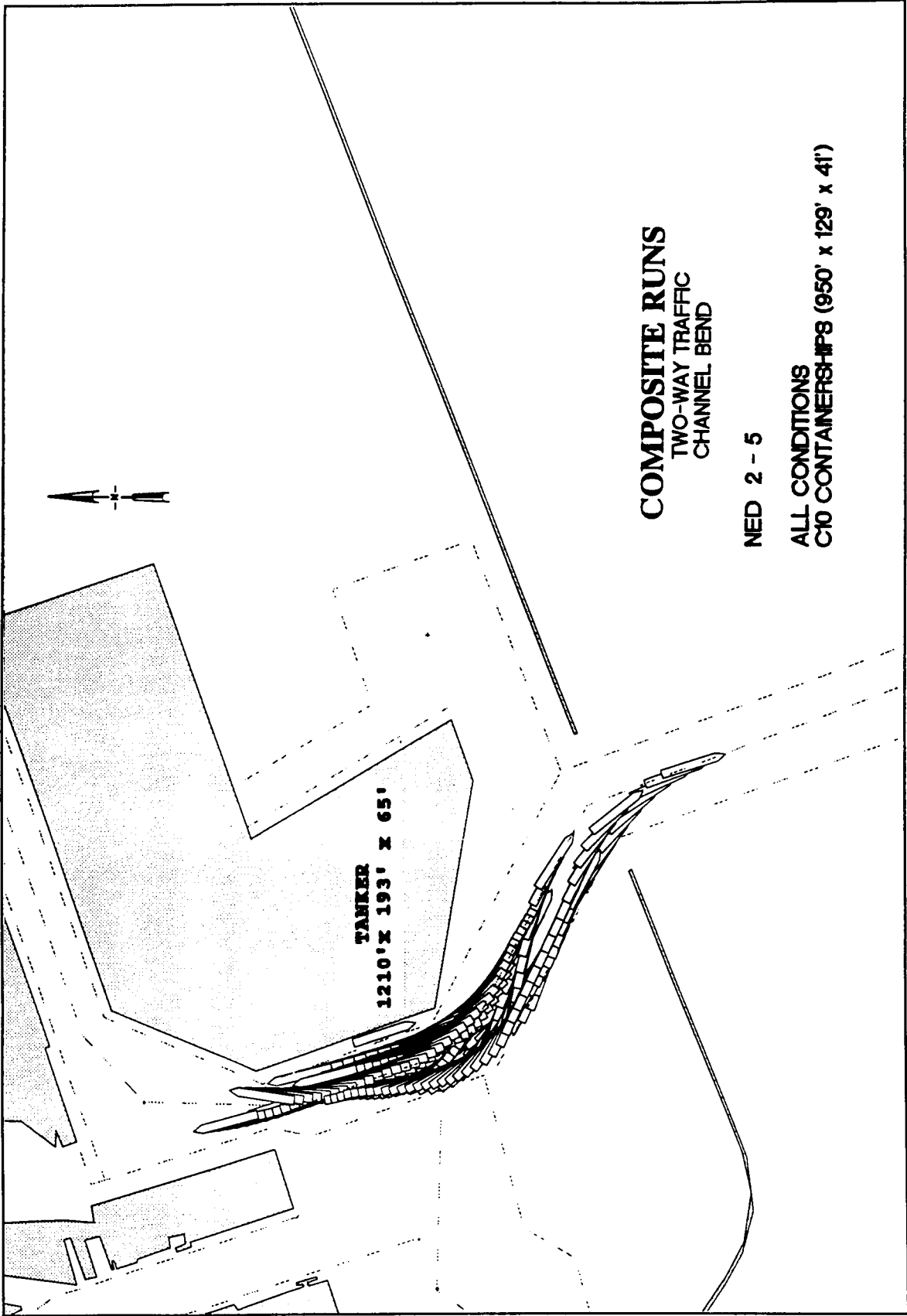

**COMPOSITE RUNS**  
TWO-WAY TRAFFIC  
CHANNEL BEND

NED 2 - 5

ALL CONDITIONS  
C10 CONTAINERS#P8 (950' x 129' x 41')

Plate 42

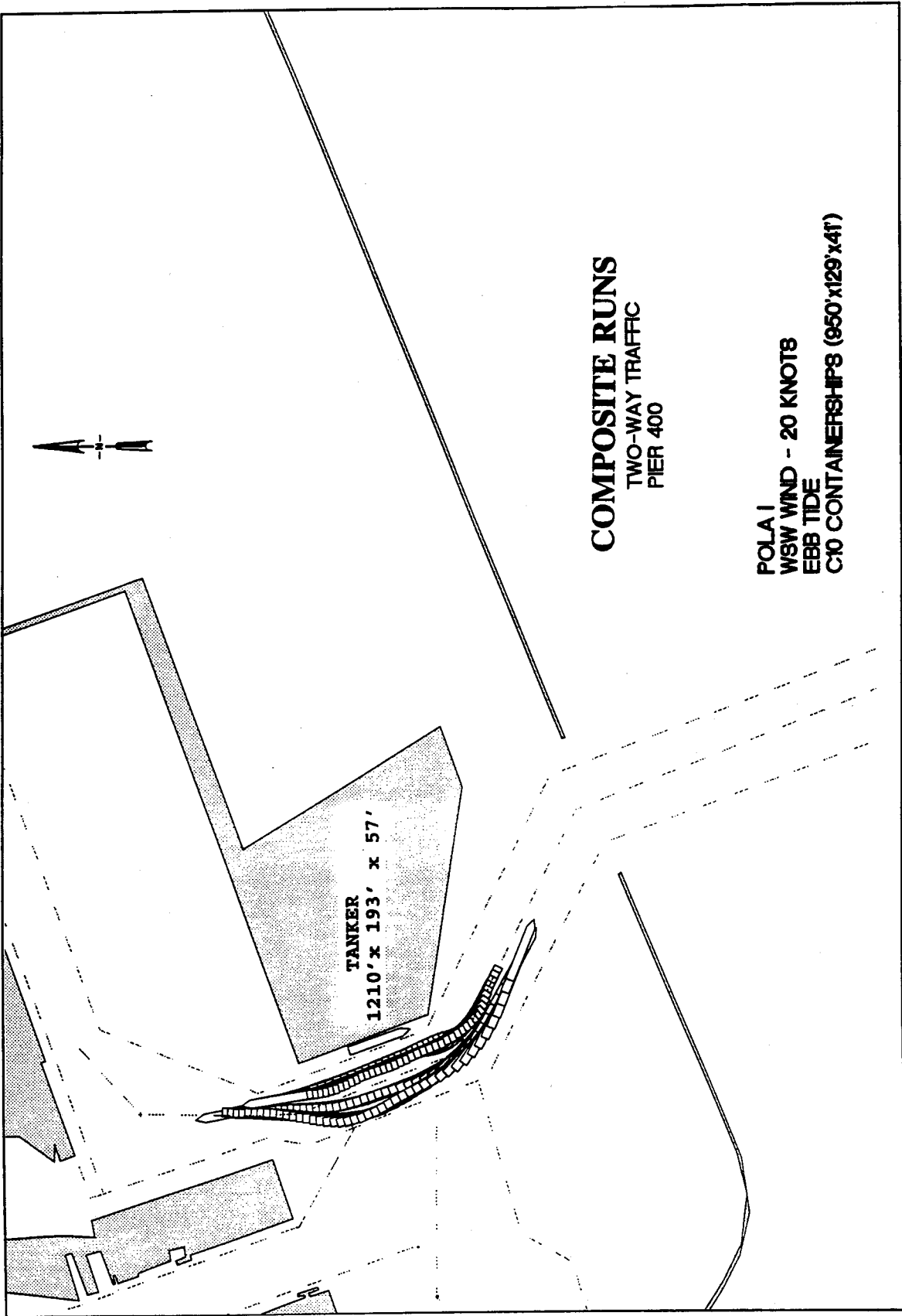
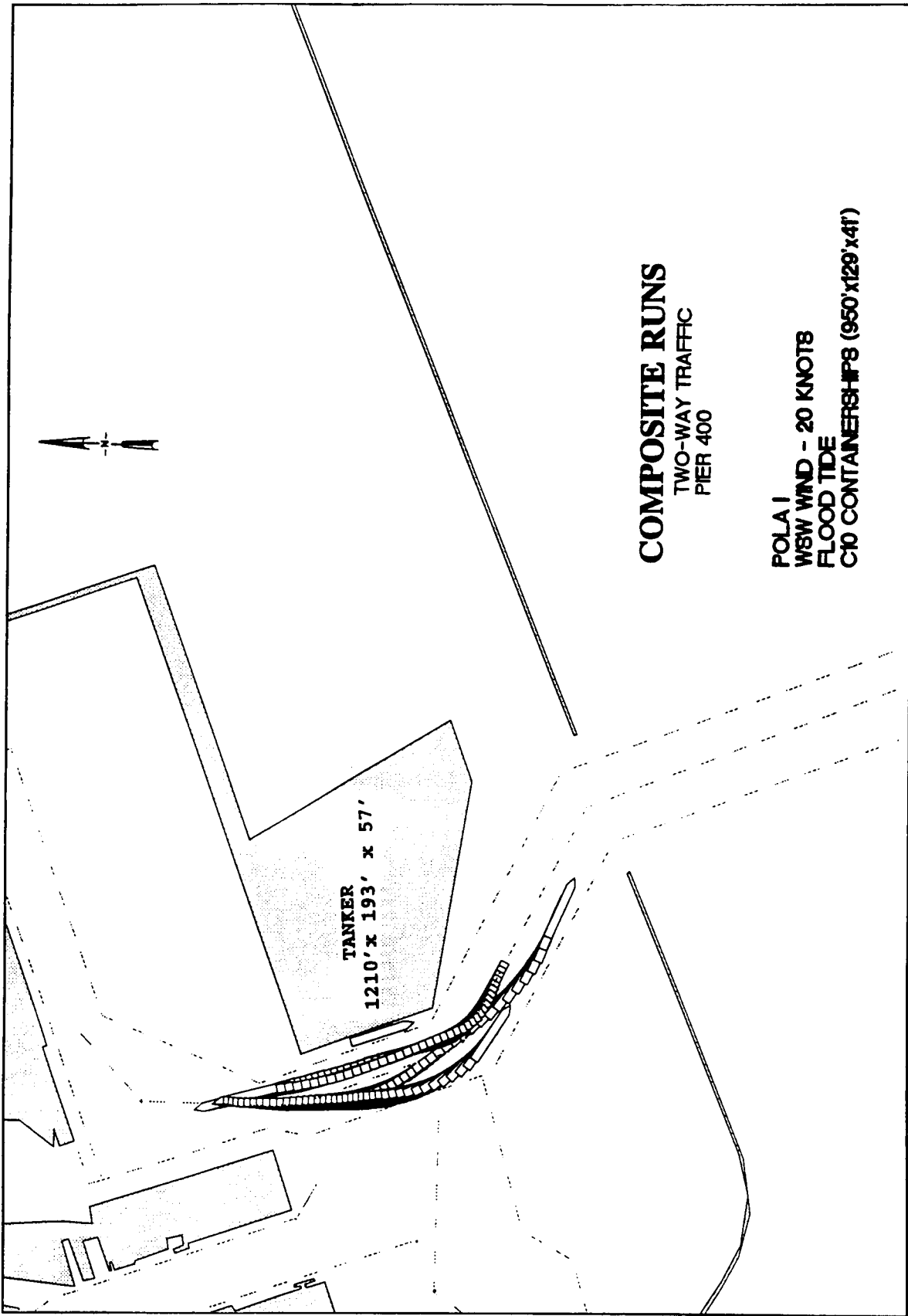

Plate 43



**COMPOSITE RUNS**

TWO-WAY TRAFFIC  
PIER 400

POLA I  
WSW WIND - 20 KNOTS  
FLOOD TIDE  
C10 CONTAINERSHIP (950'x129'x41')

Plate 44

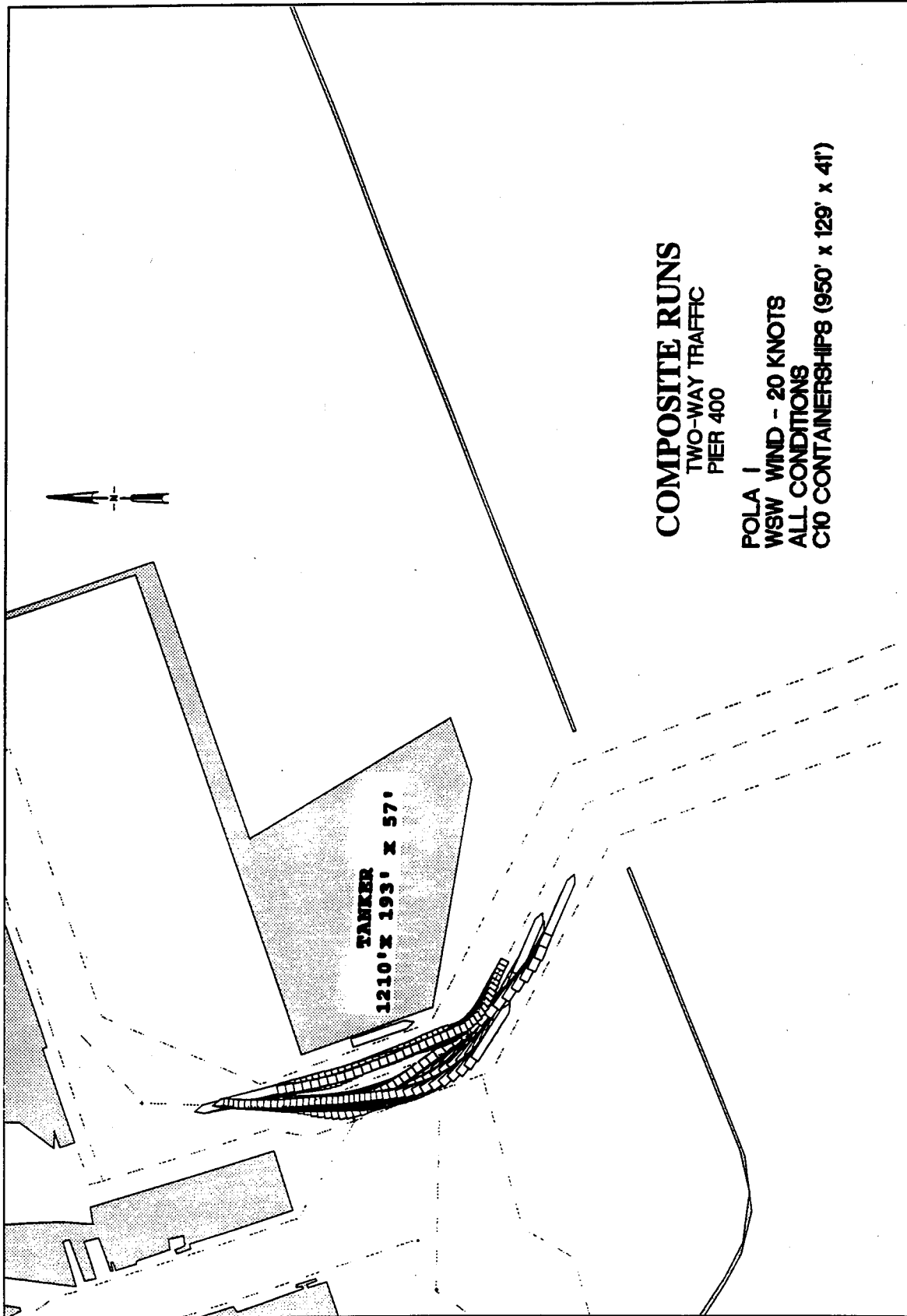

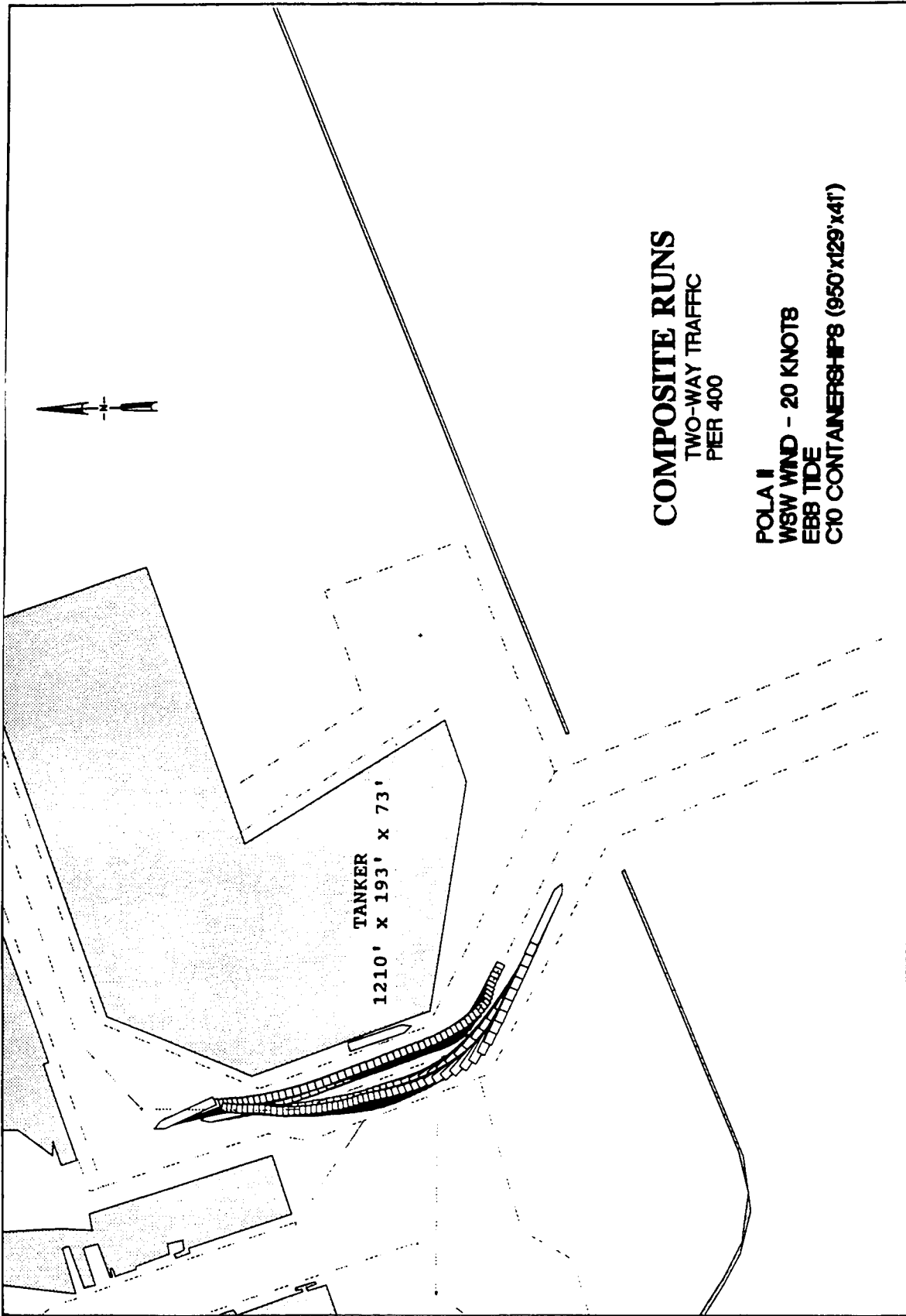

**COMPOSITE RUNS**

TWO-WAY TRAFFIC  
PIER 400

**POLA II**  
WSW WIND - 20 KNOTS  
EBB TIDE  
C10 CONTAINERSHIP8 (950'x129'x41')

Plate 46

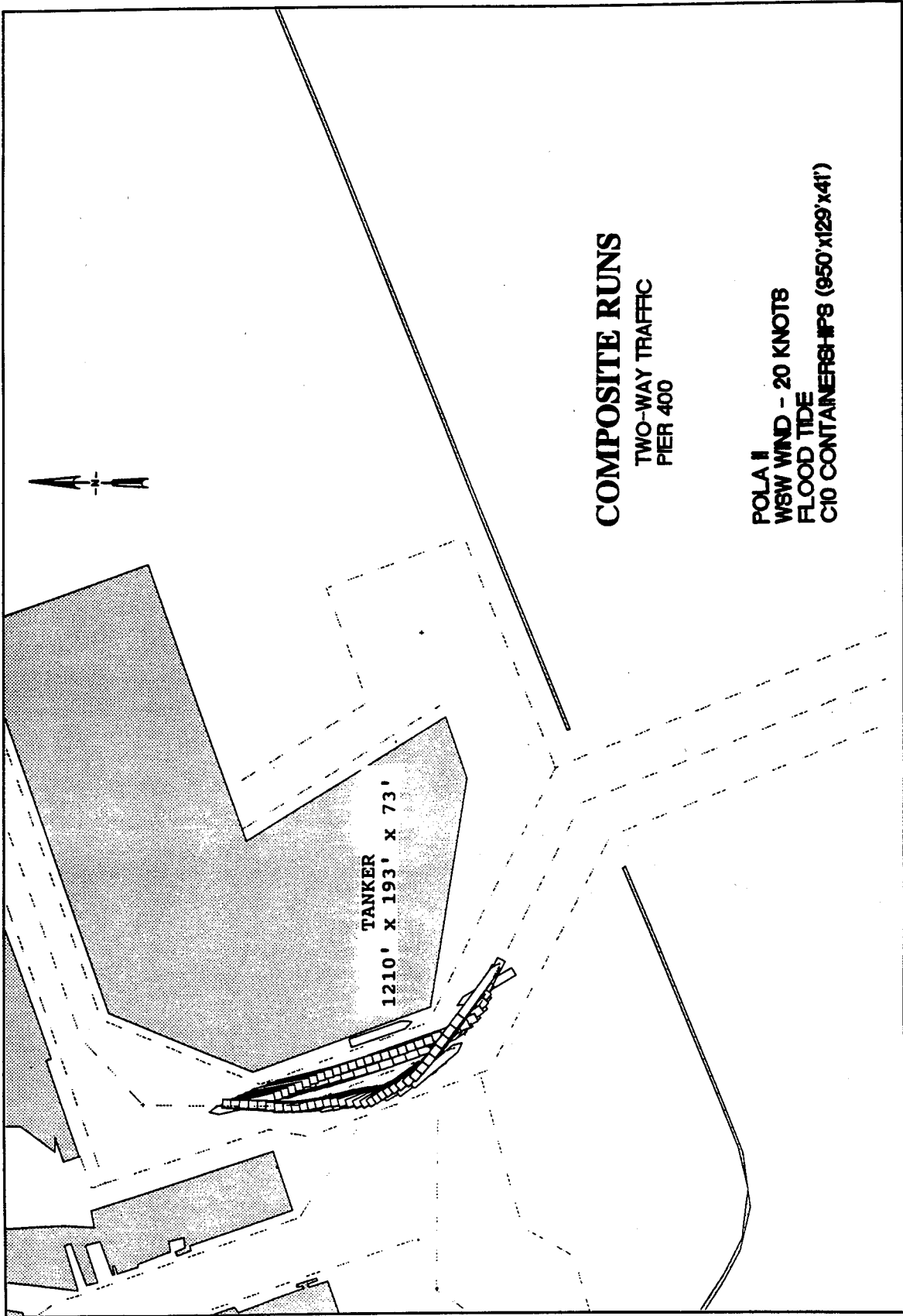

**COMPOSITE RUNS**  
TWO-WAY TRAFFIC  
PIER 400

**POLA II**  
WSW WIND - 20 KNOTS  
FLOOD TIDE  
C10 CONTAINERSHP8 (950'x129'x41')

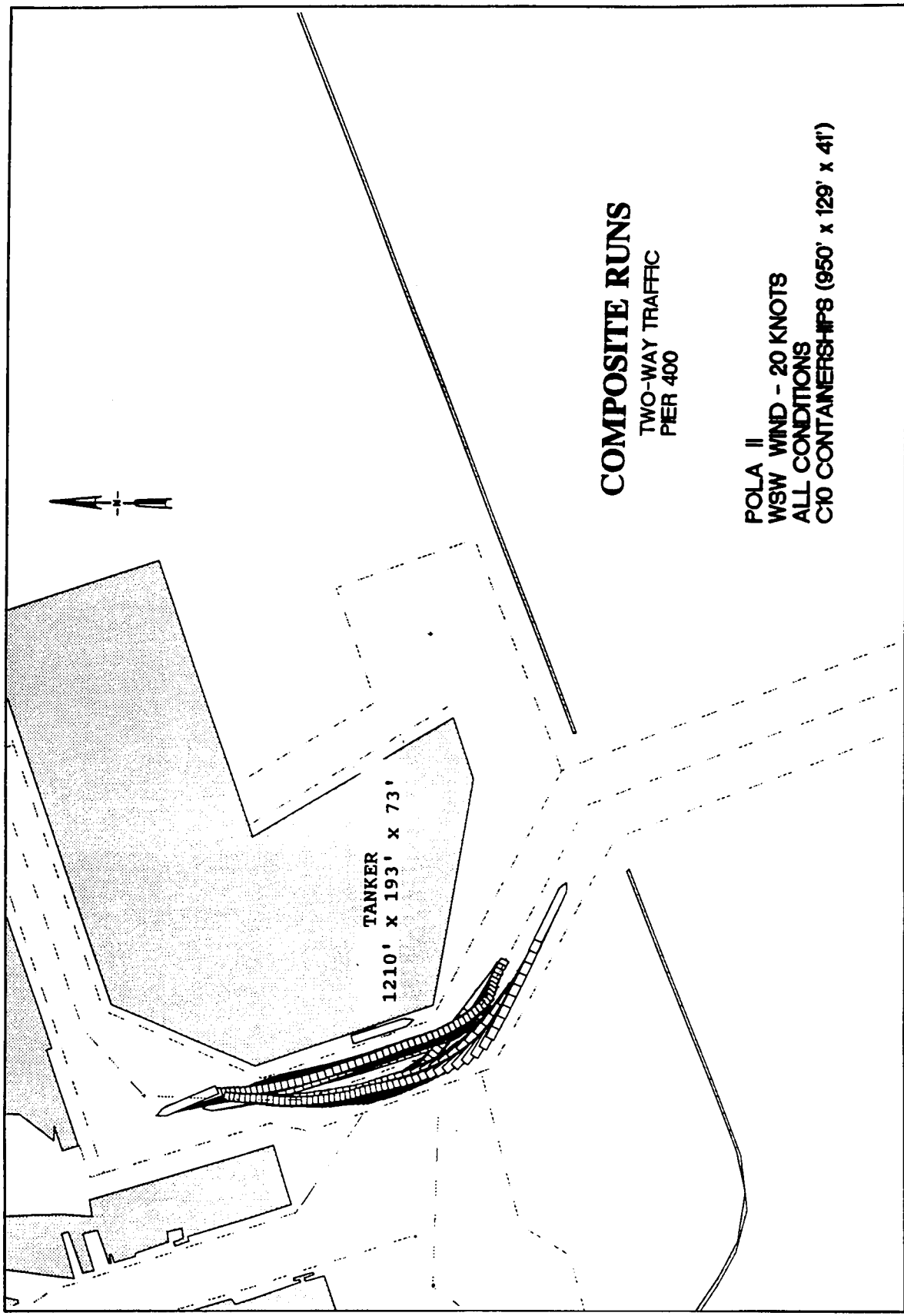

**COMPOSITE RUNS**

TWO-WAY TRAFFIC  
PER 400

POLA II  
WSW WIND - 20 KNOTS  
ALL CONDITIONS  
C10 CONTAINERS#P8 (950' x 129' x 41')

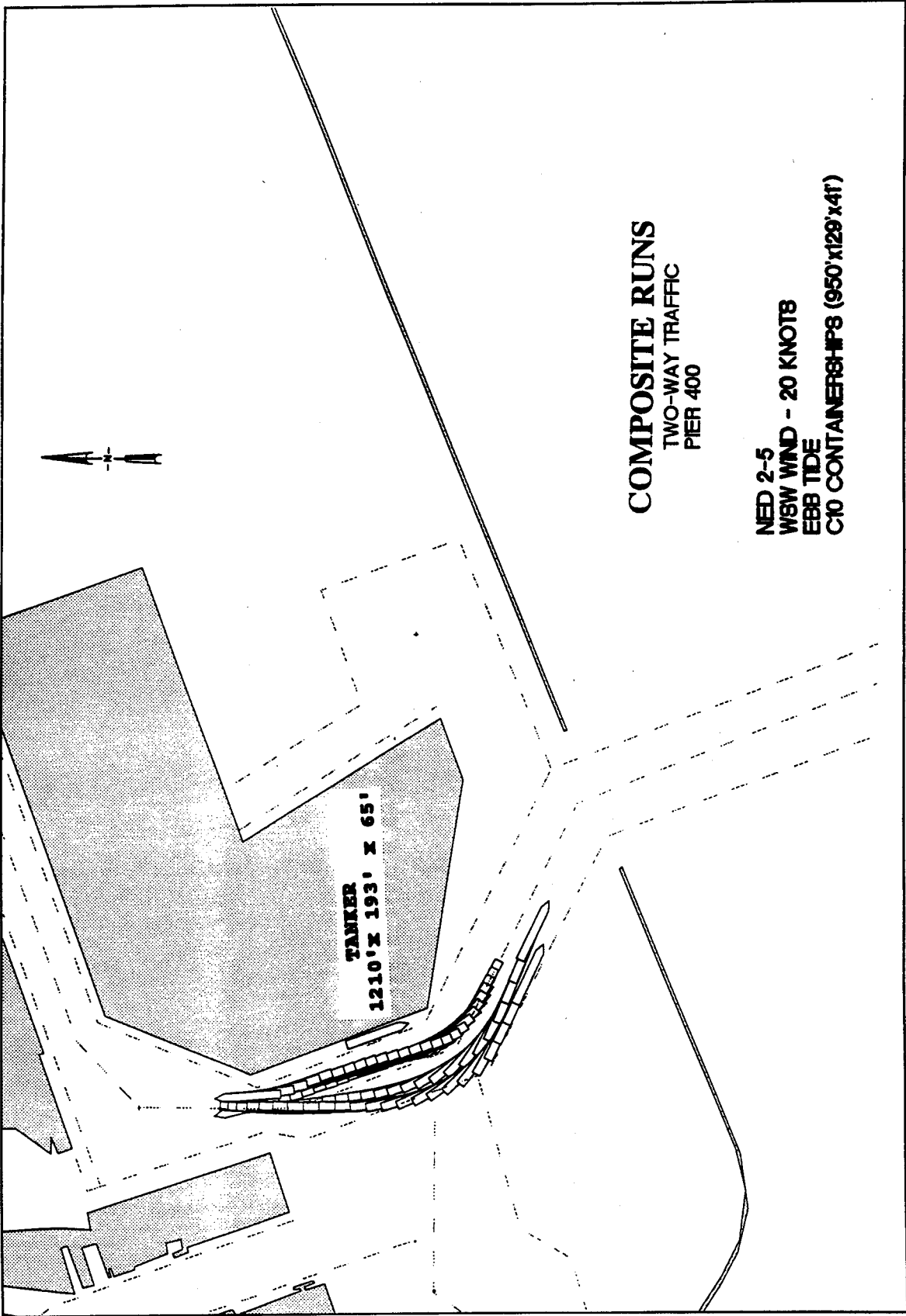

**COMPOSITE RUNS**  
TWO-WAY TRAFFIC  
PIER 400

NED 2-5  
WSW WIND - 20 KNOTS  
EBB TIDE  
C10 CONTAINERSHP8 (950'x129'x41')

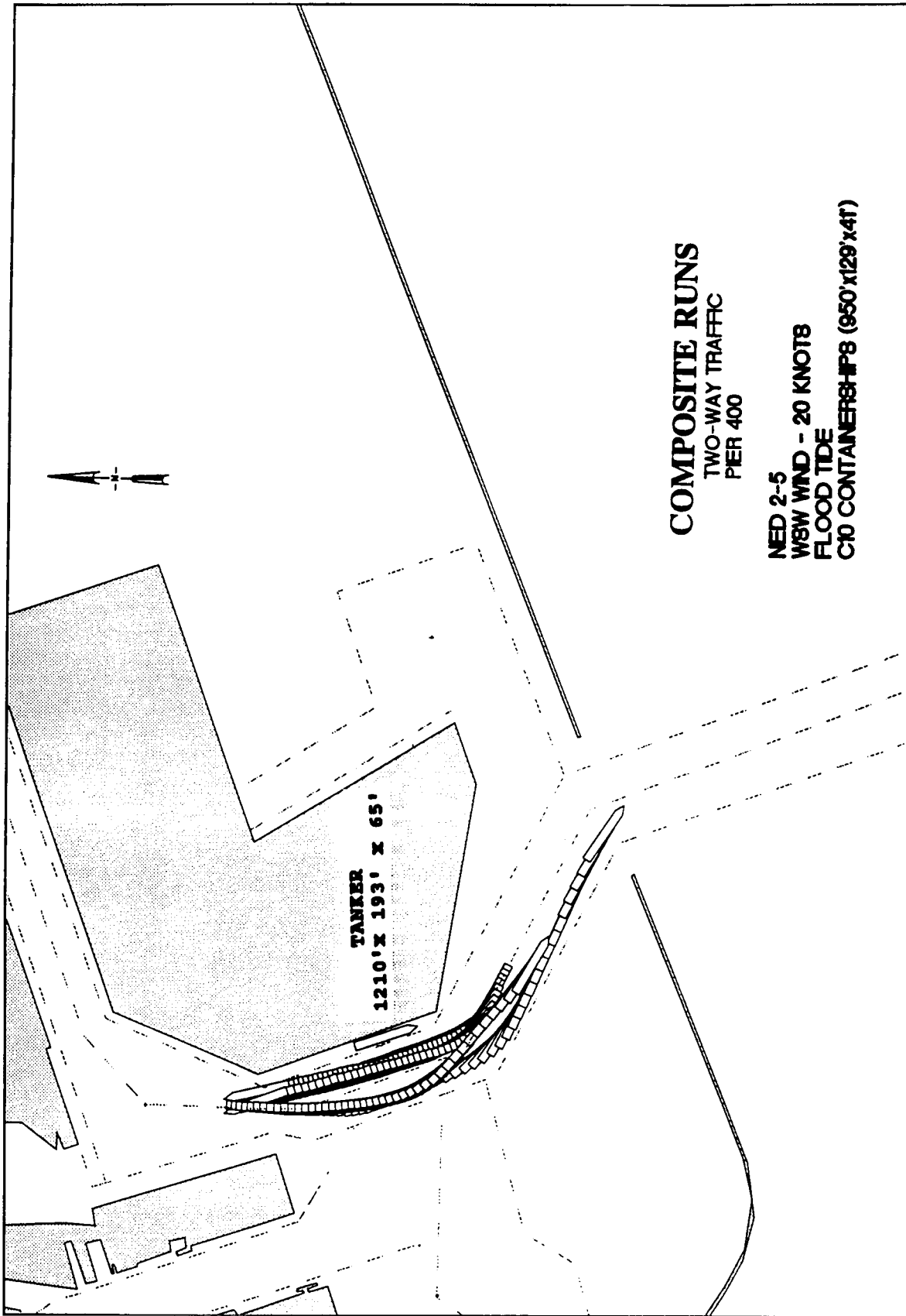
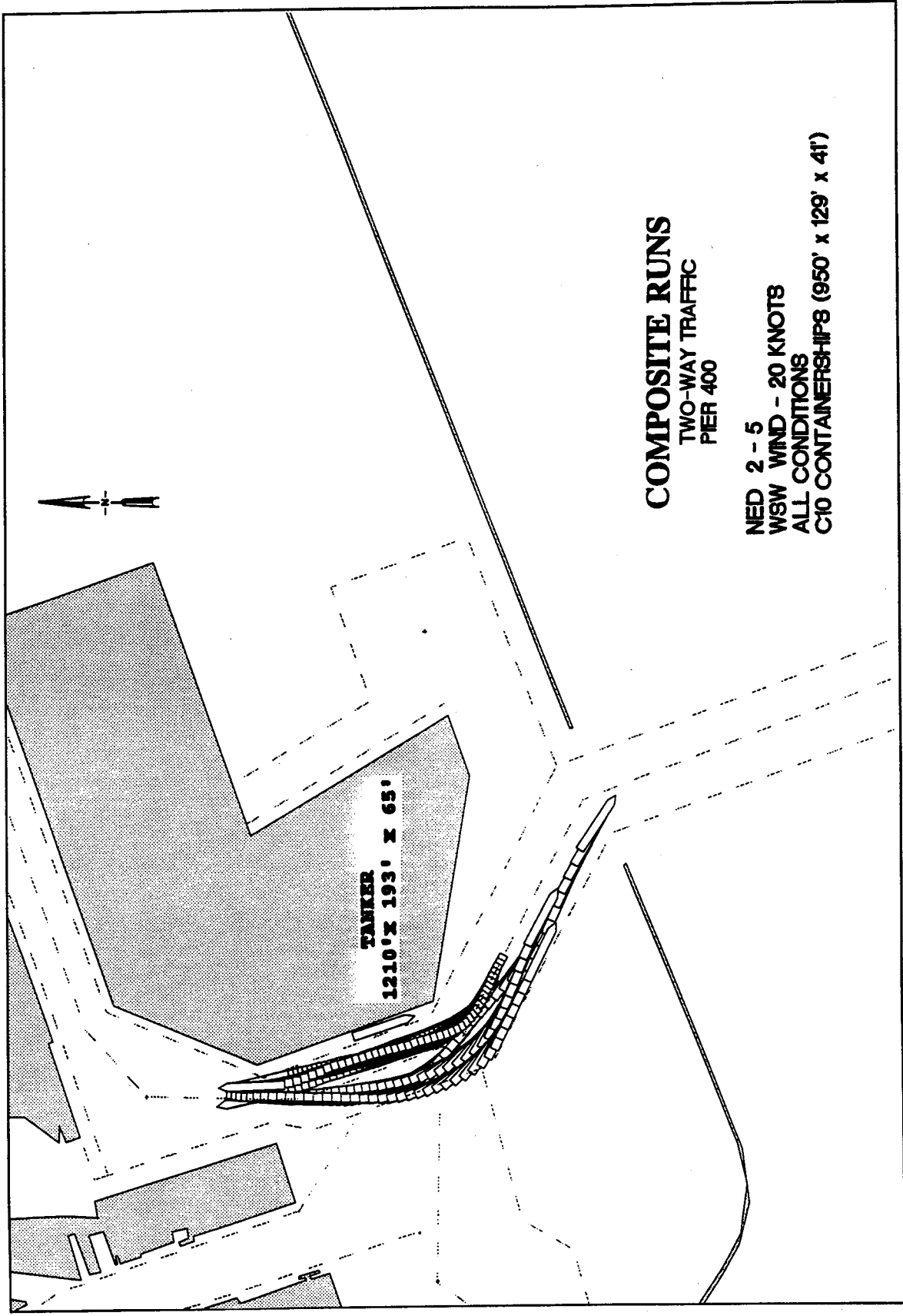

Plate 50



**COMPOSITE RUNS**

TWO-WAY TRAFFIC  
PIER 400

NED 2 - 5  
WSW WIND - 20 KNOTS  
ALL CONDITIONS  
C10 CONTAINERSHIP8 (950' x 129' x 41')

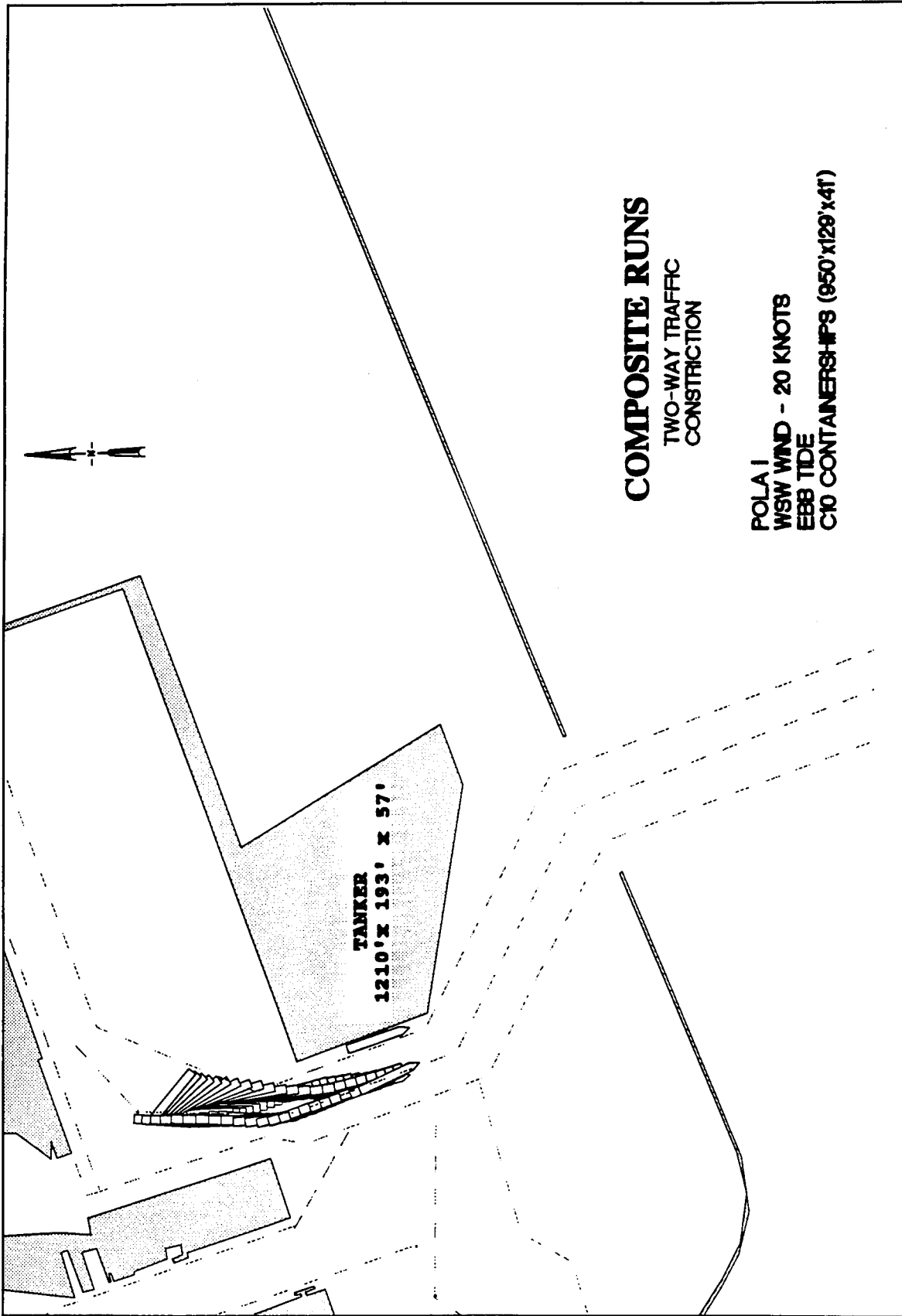
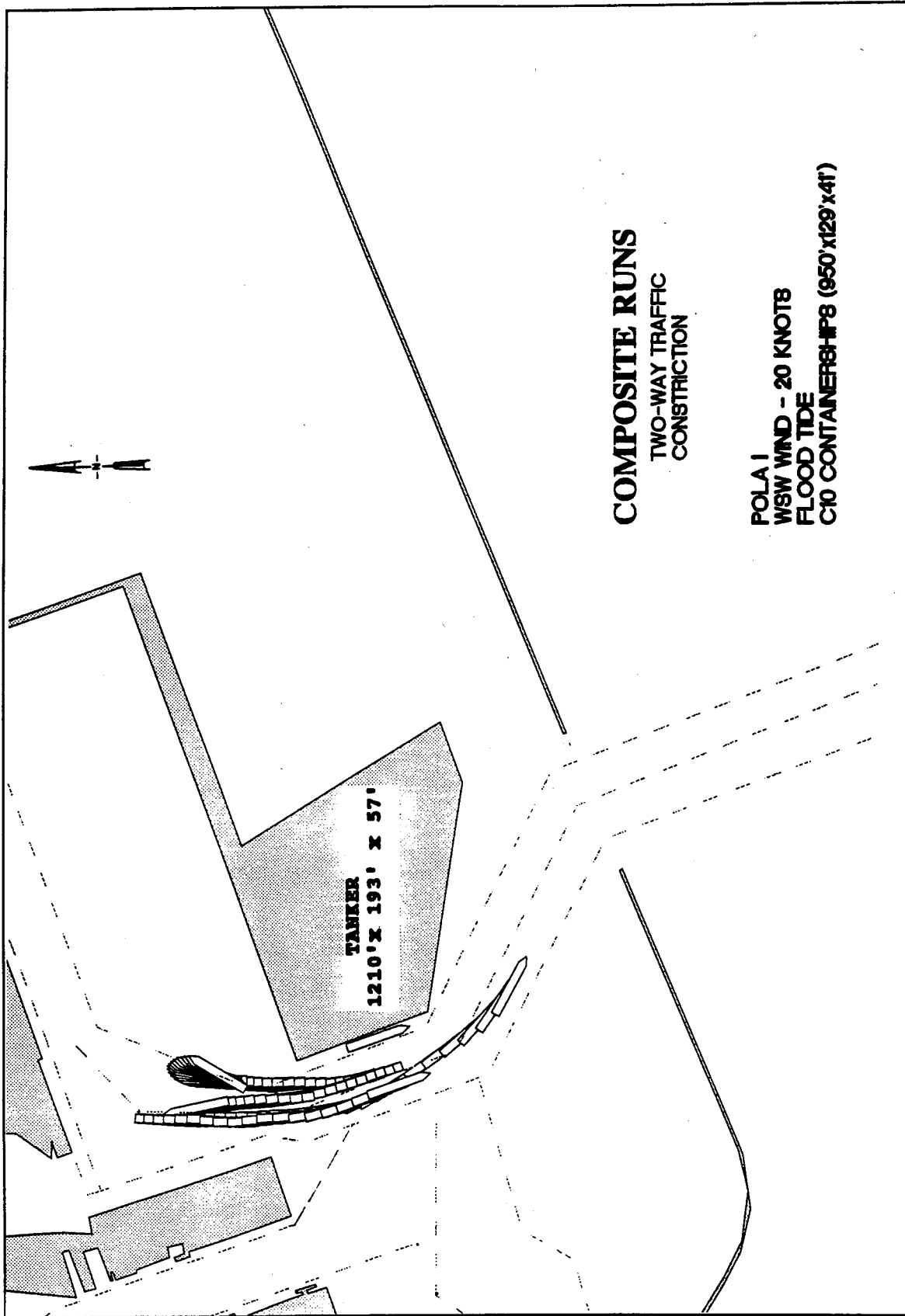
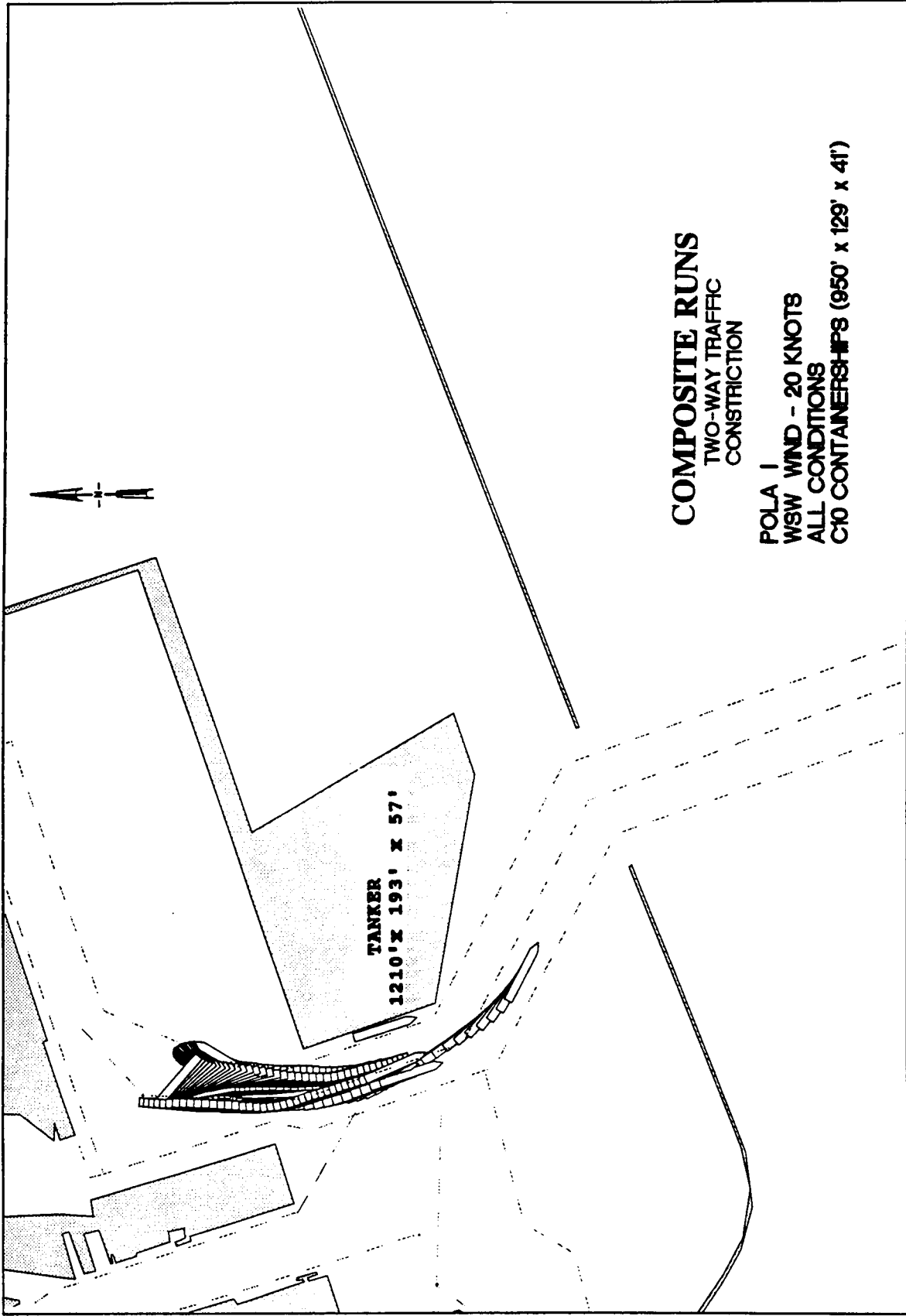

Plate 52



**COMPOSITE RUNS**  
TWO-WAY TRAFFIC  
CONSTRUCTION

POLA I  
WSW WIND - 20 KNOTS  
FLOOD TIDE  
C10 CONTAINER HP8 (950'x129'x41')



**COMPOSITE RUNS**  
TWO-WAY TRAFFIC  
CONSTRUCTION

POLA I  
WSW WIND - 20 KNOTS  
ALL CONDITIONS  
C10 CONTAINERS (950' x 129' x 41')

Plate 54

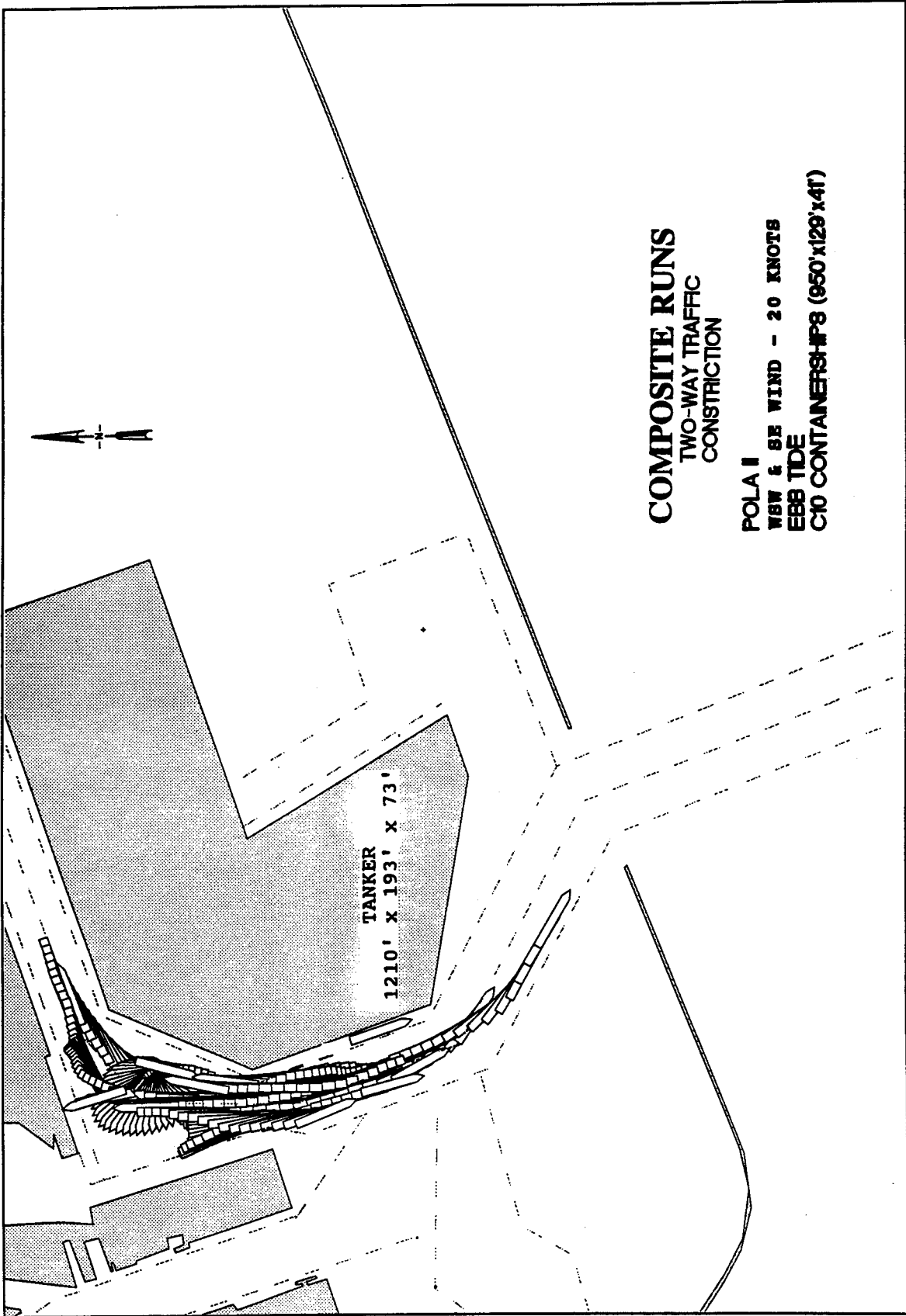

**COMPOSITE RUNS**  
TWO-WAY TRAFFIC  
CONSTRUCTION

**POLA II**  
WSW & SE WIND - 20 KNOTS  
EBB TIDE  
C10 CONTAINERSHP8 (950'x129'x41')

TANKER  
1210' x 193' x 73'

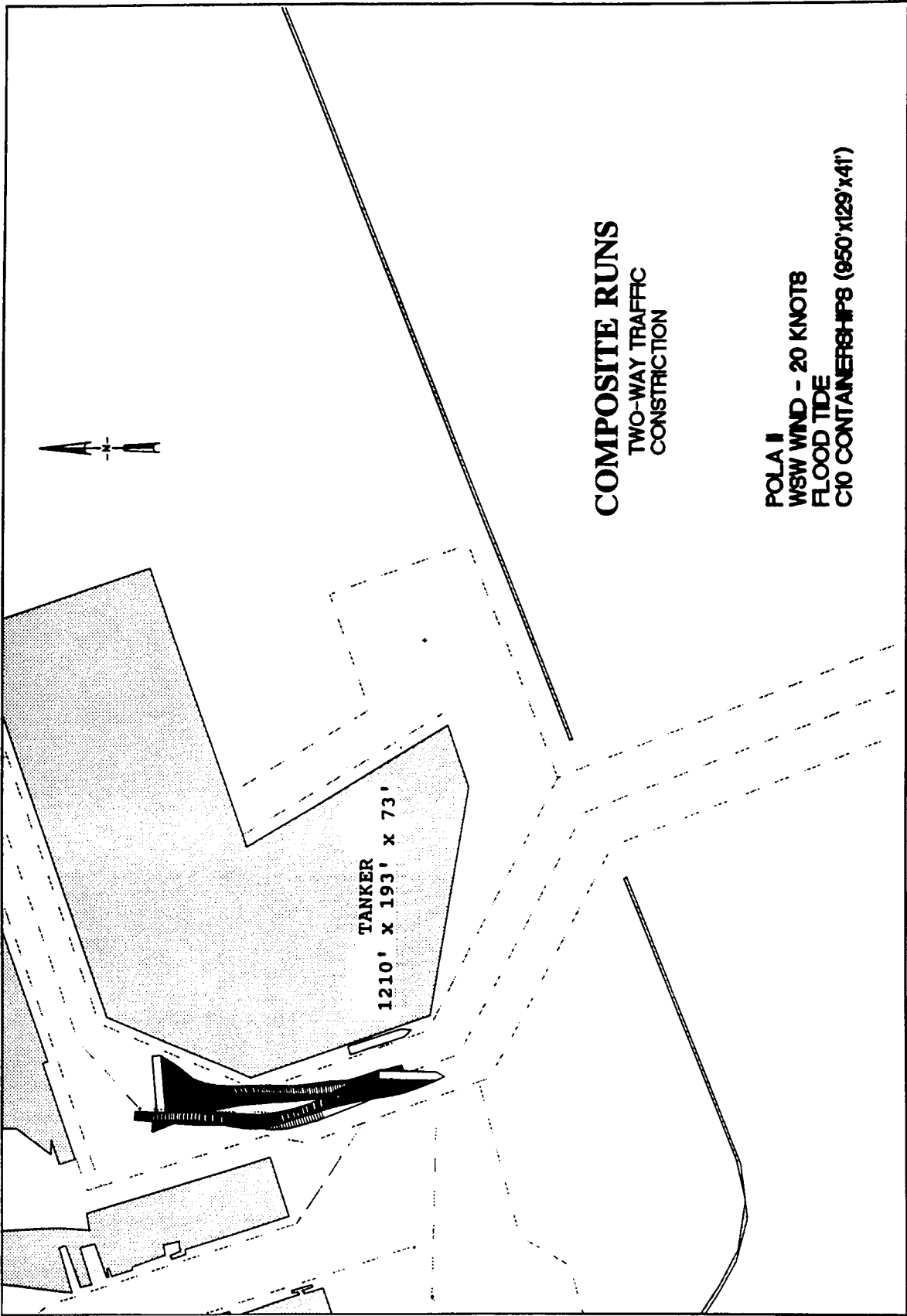

**COMPOSITE RUNS**  
TWO-WAY TRAFFIC  
CONSTRUCTION

**POLA II**  
WSW WIND - 20 KNOTS  
FLOOD TIDE  
C10 CONTAINERSHP8 (950'x129'x41')

TANKER  
1210' x 193' x 73'

Plate 56

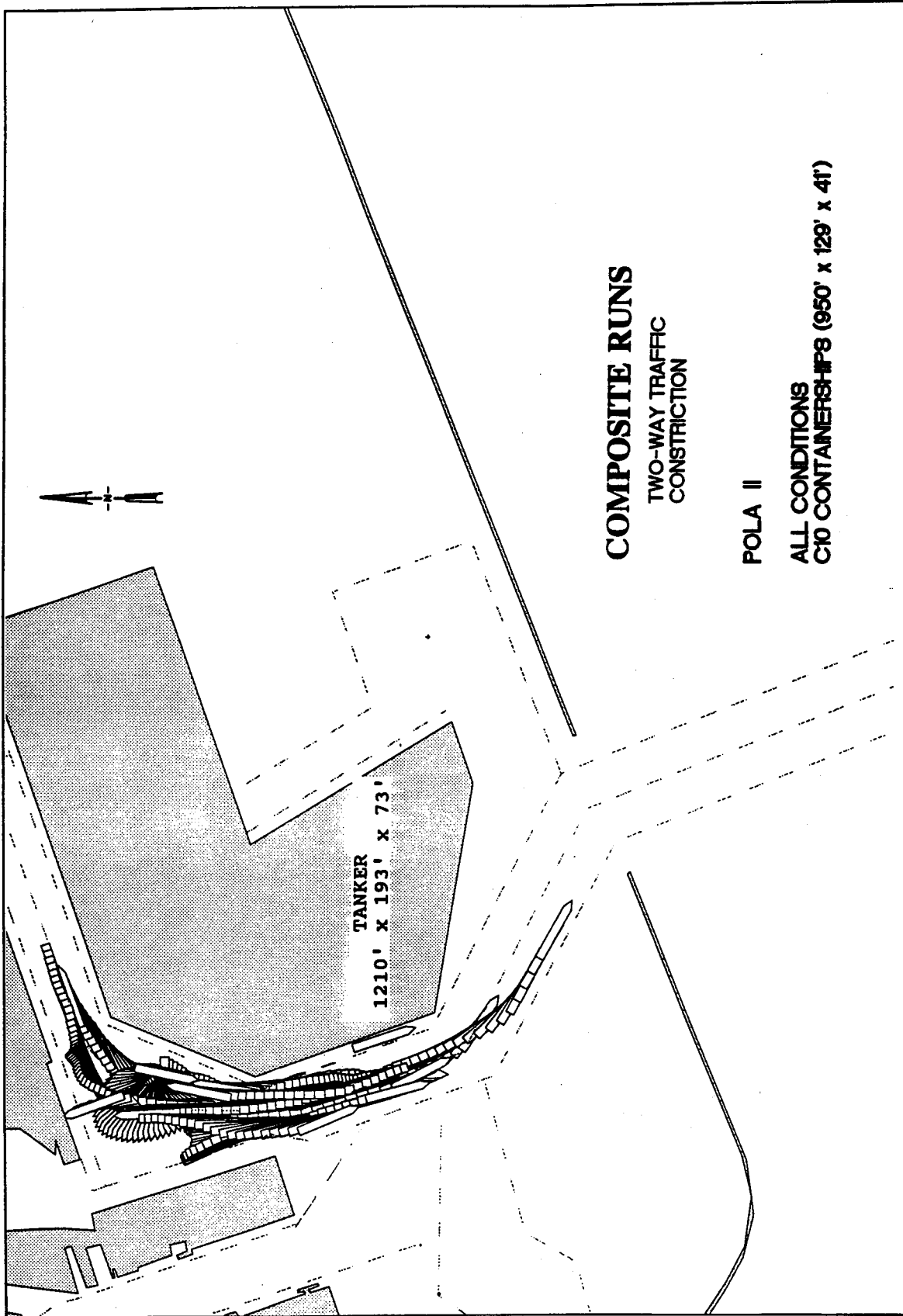

**COMPOSITE RUNS**

**TWO-WAY TRAFFIC  
CONSTRUCTION**

**POLA II**

**ALL CONDITIONS  
C10 CONTAINERSHP8 (950' x 129' x 41')**

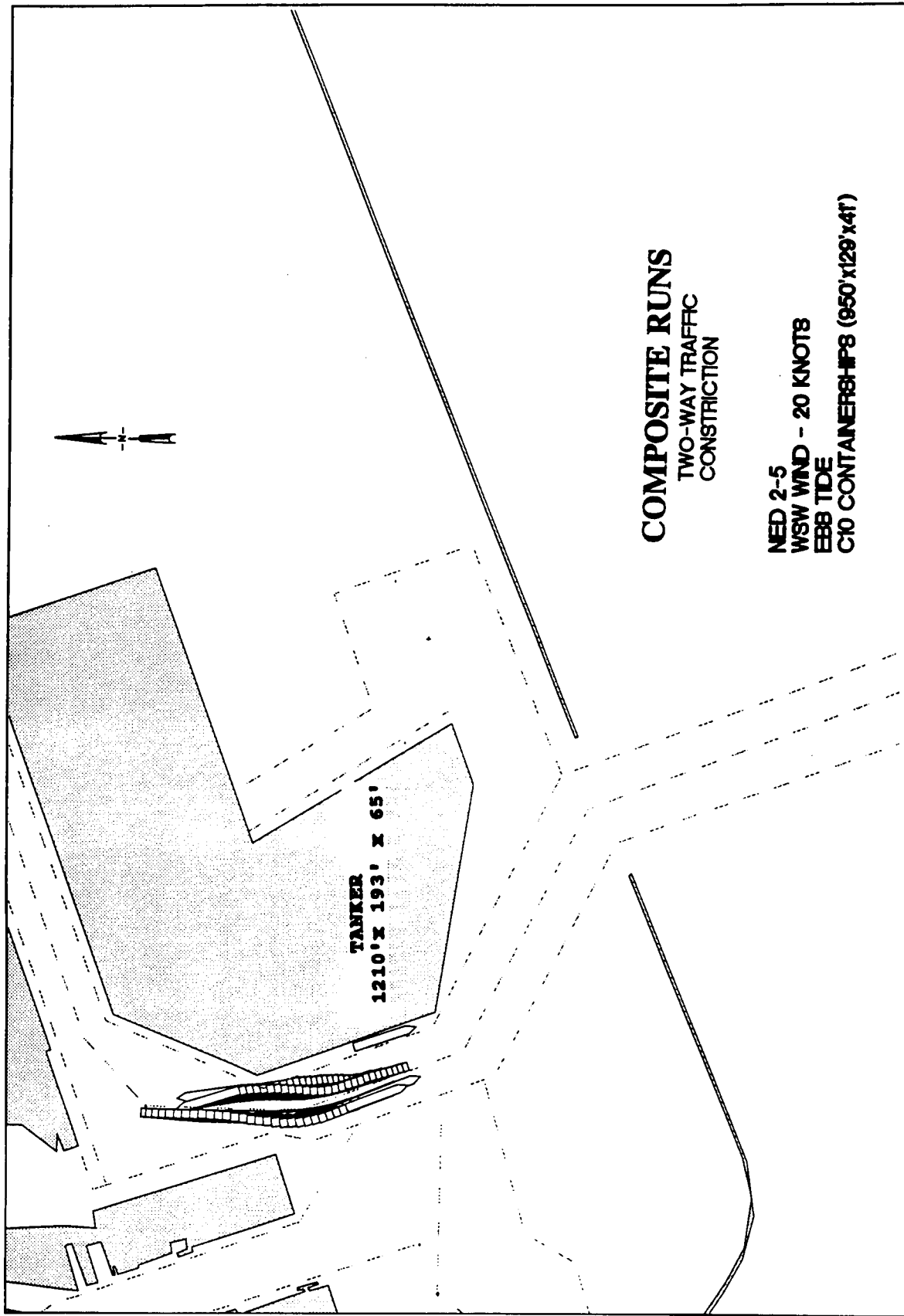

**COMPOSITE RUNS**  
TWO-WAY TRAFFIC  
CONSTRICTION

NEED 2-5  
WSW WIND - 20 KNOTS  
EBB TIDE  
C10 CONTAINERSHIP8 (950' X 129' X 41')

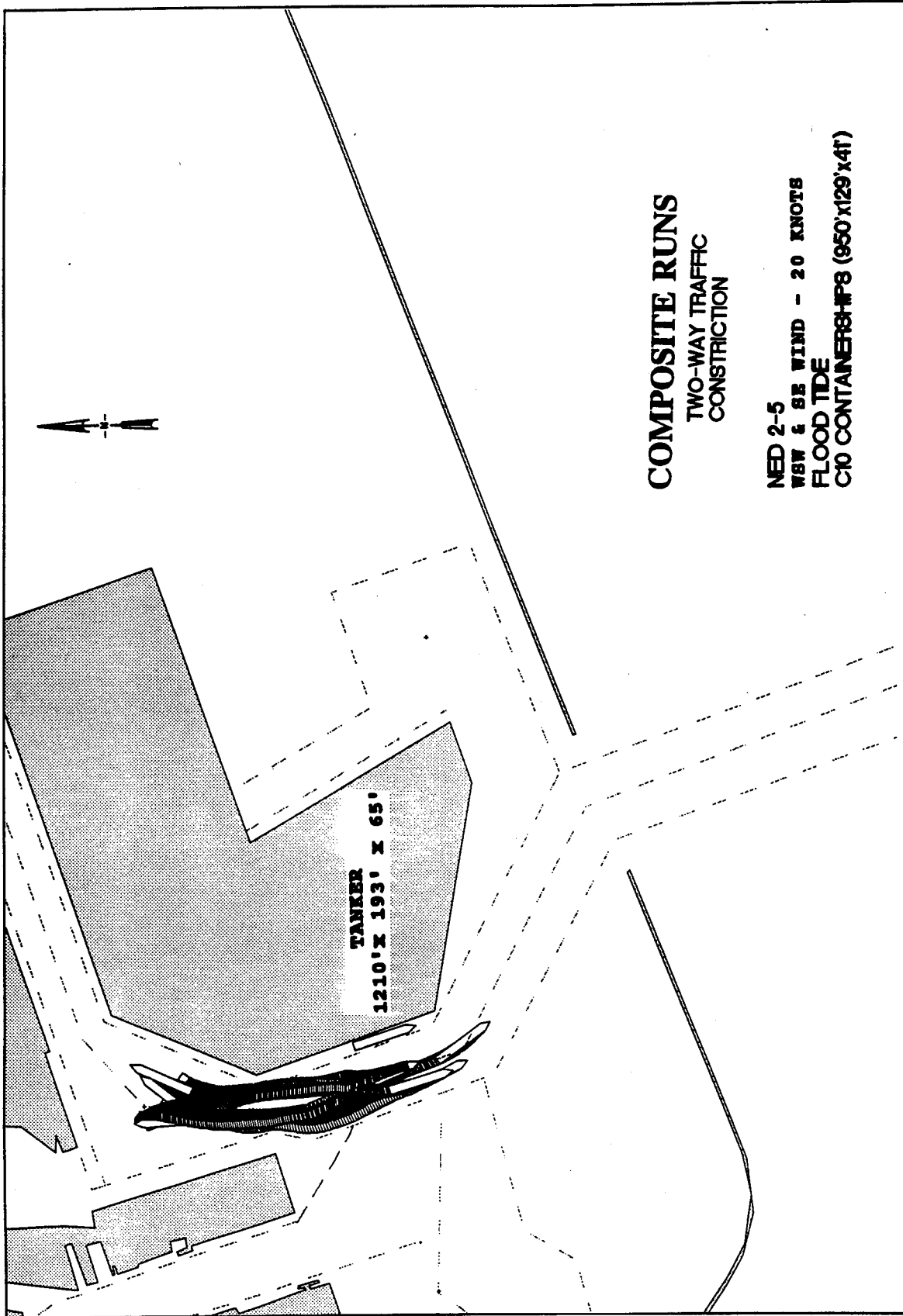

**COMPOSITE RUNS**

**TWO-WAY TRAFFIC  
CONSTRUCTION**

**NED 2-5  
WBW & SE WIND - 20 KNOTS  
FLOOD TIDE  
C10 CONTAINERS (950' X 129' X 41')**

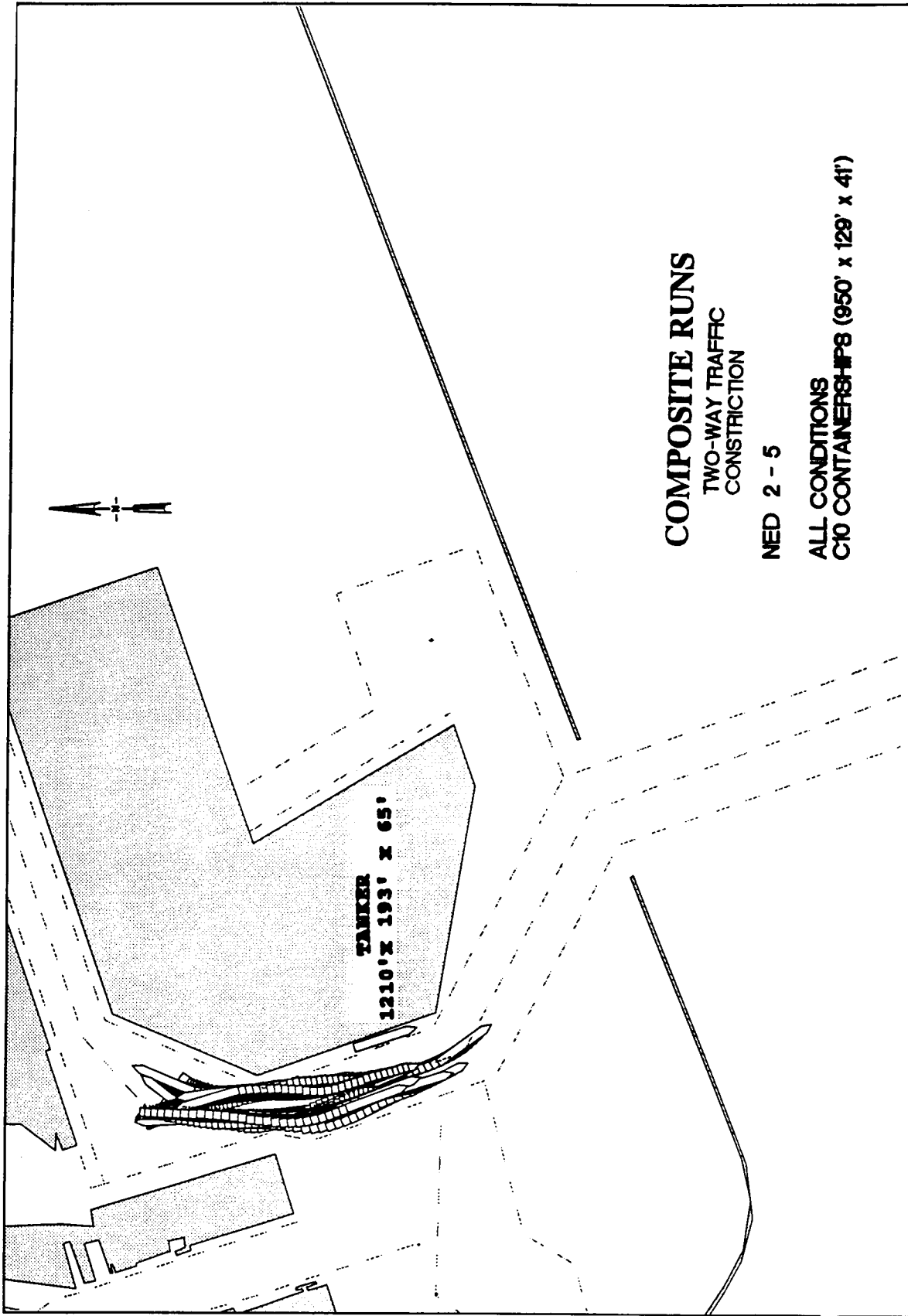

**COMPOSITE RUNS**

TWO-WAY TRAFFIC  
CONSTRUCTION

NED 2 - 5

ALL CONDITIONS  
C10 CONTAINERS #8 (950' x 129' x 41')

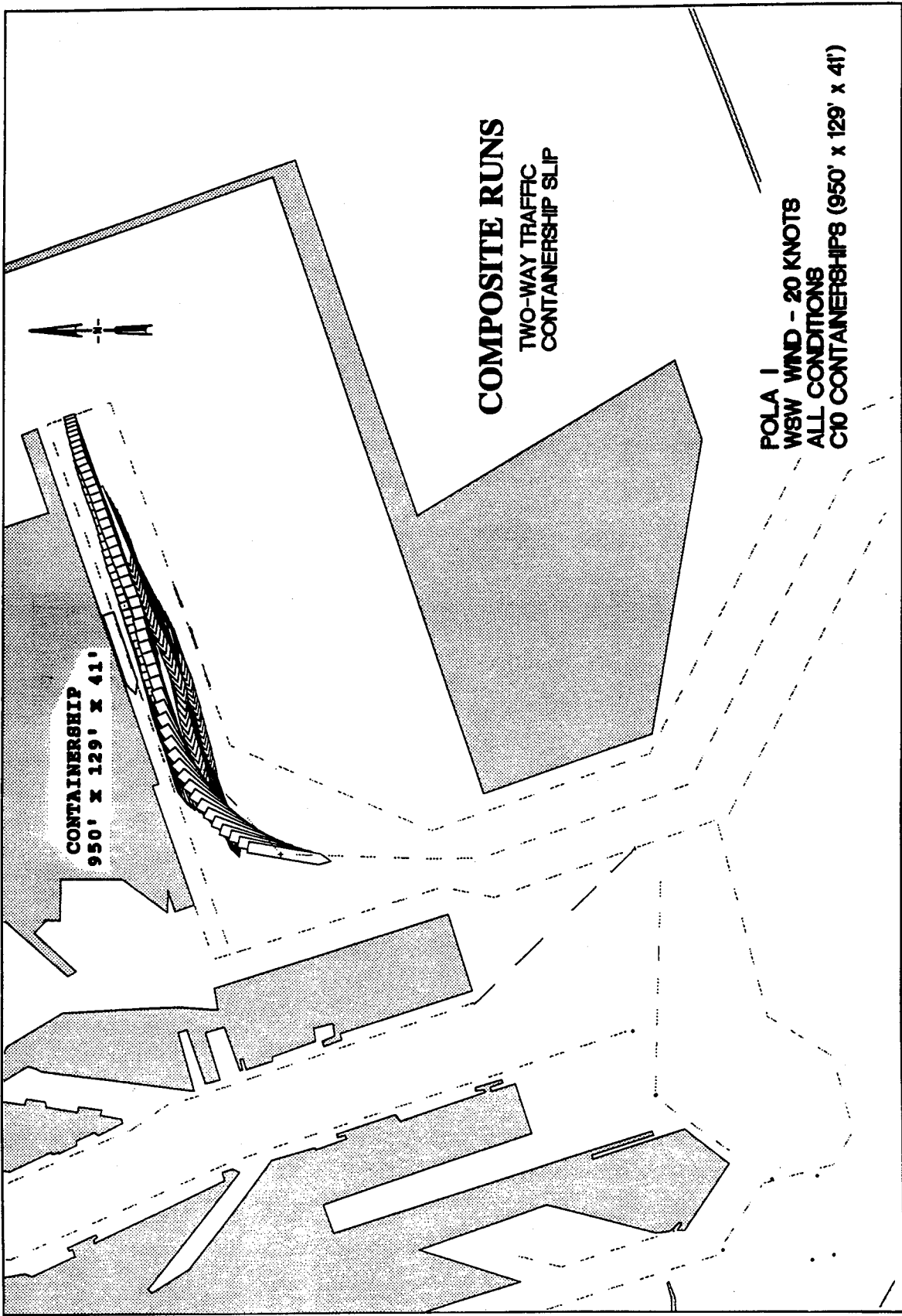

CONTAINERSHIP  
950' x 129' x 41'

COMPOSITE RUNS  
TWO-WAY TRAFFIC  
CONTAINERSHIP SLIP

POLA I  
WSW WIND - 20 KNOTS  
ALL CONDITIONS  
C10 CONTAINERSHIP8 (950' x 129' x 41')

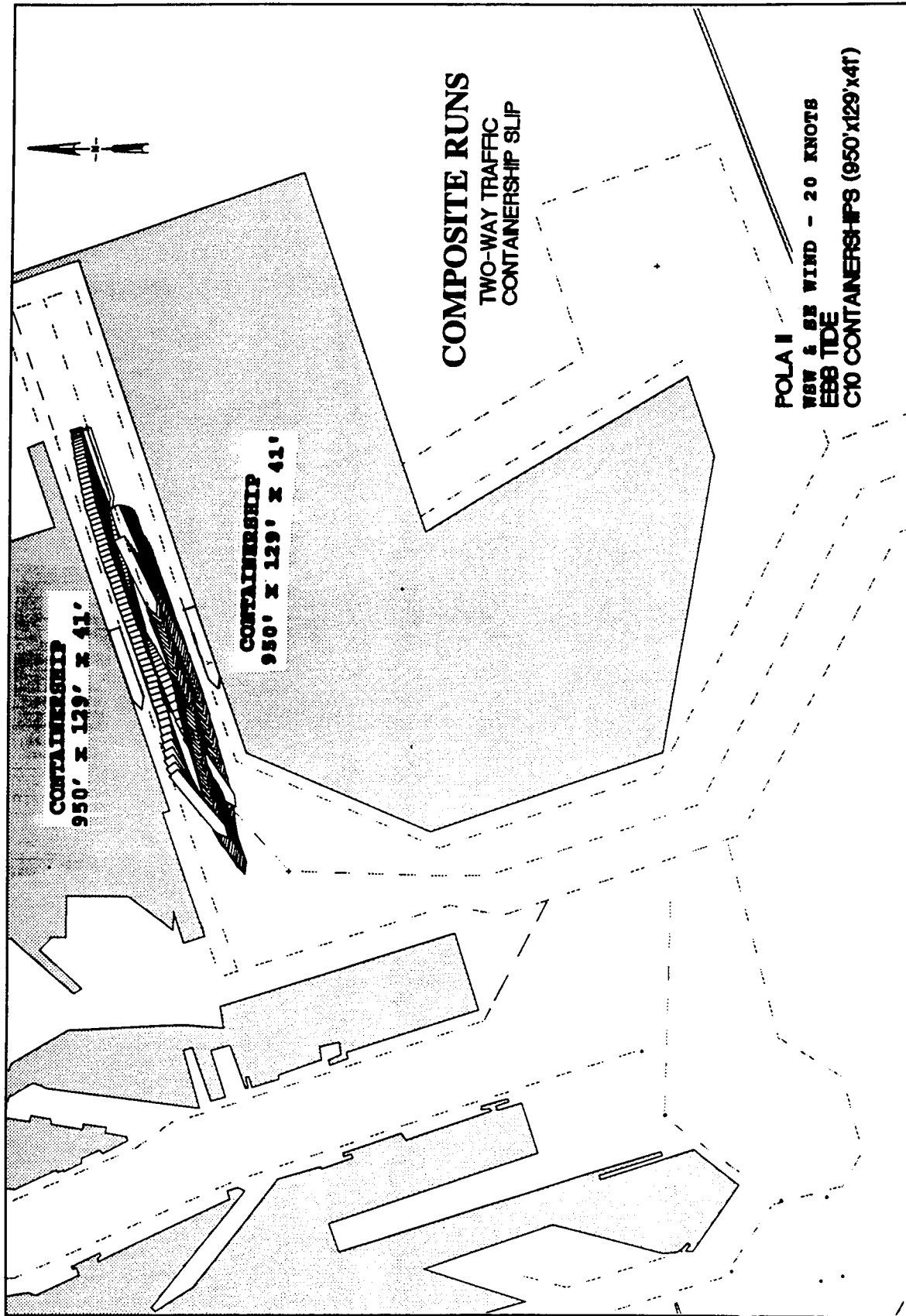
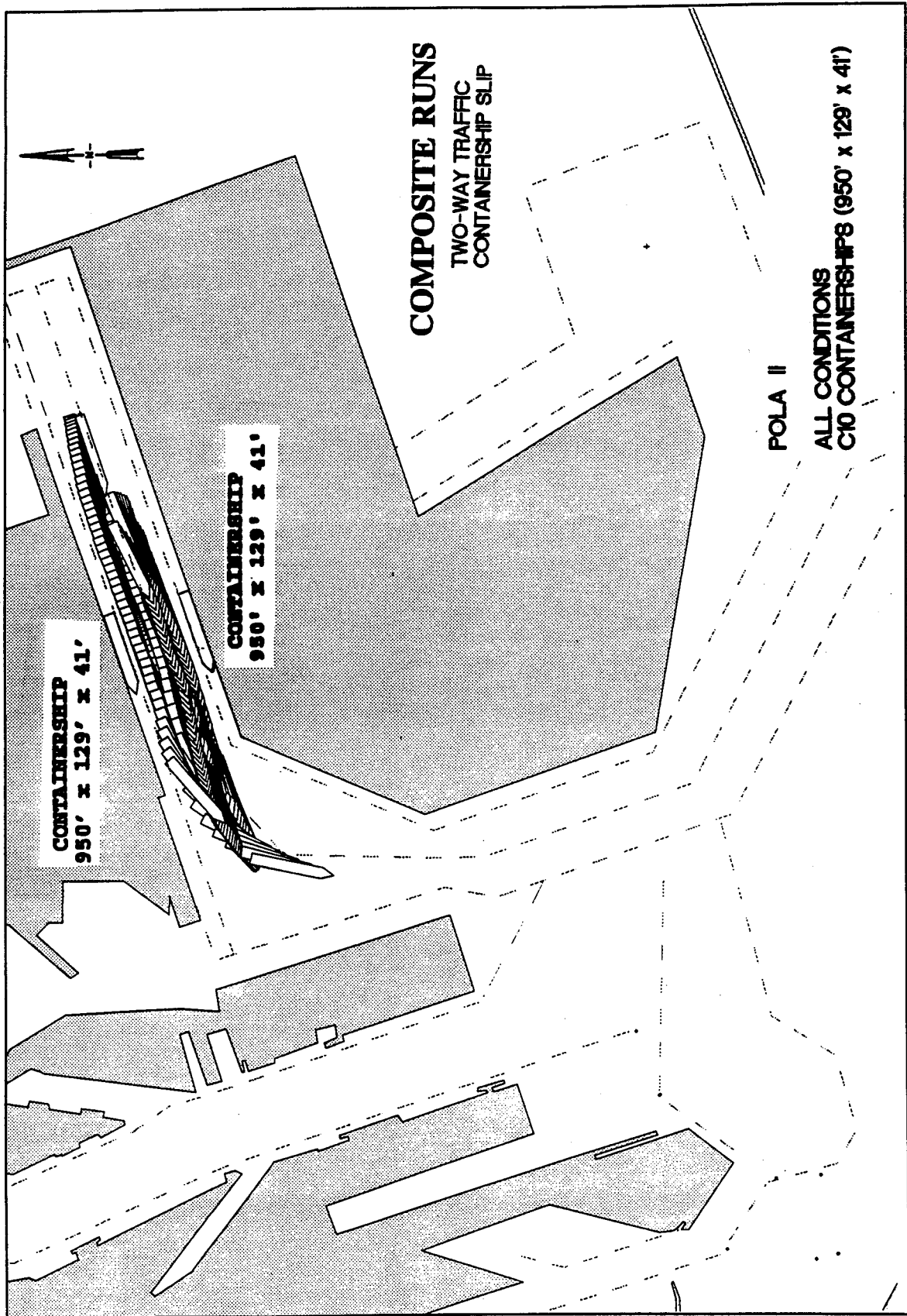
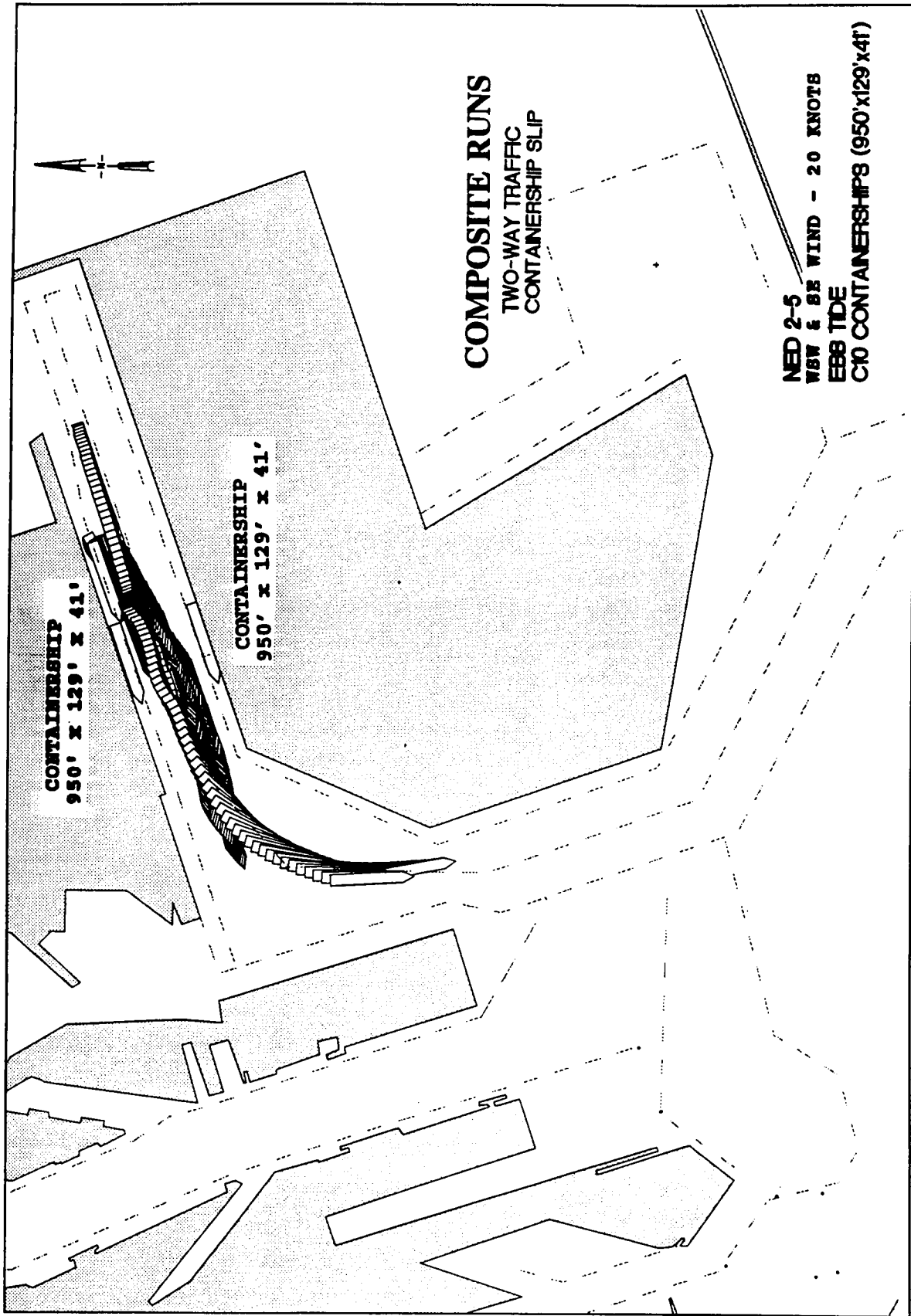

Plate 62





**COMPOSITE RUNS**  
 TWO-WAY TRAFFIC  
 CONTAINERSHIP SLIP

NEED 2-5  
 W&W & SE WIND - 20 KNOTS  
 EBB TIDE  
 C10 CONTAINERSHIPS (950'x129'x41')

CONTAINERSHIP  
 950' x 129' x 41'

CONTAINERSHIP  
 950' x 129' x 41'

Plate 64

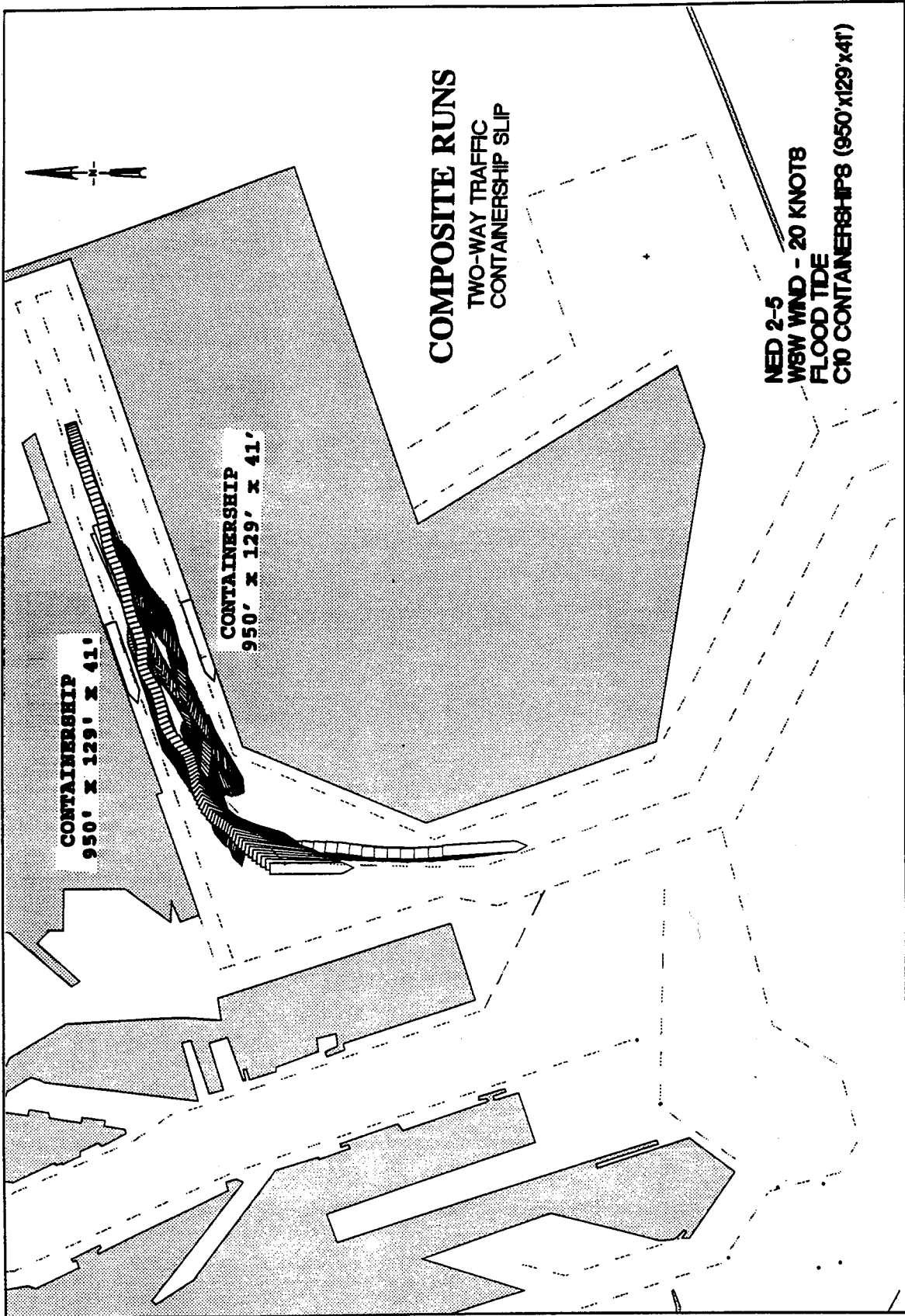

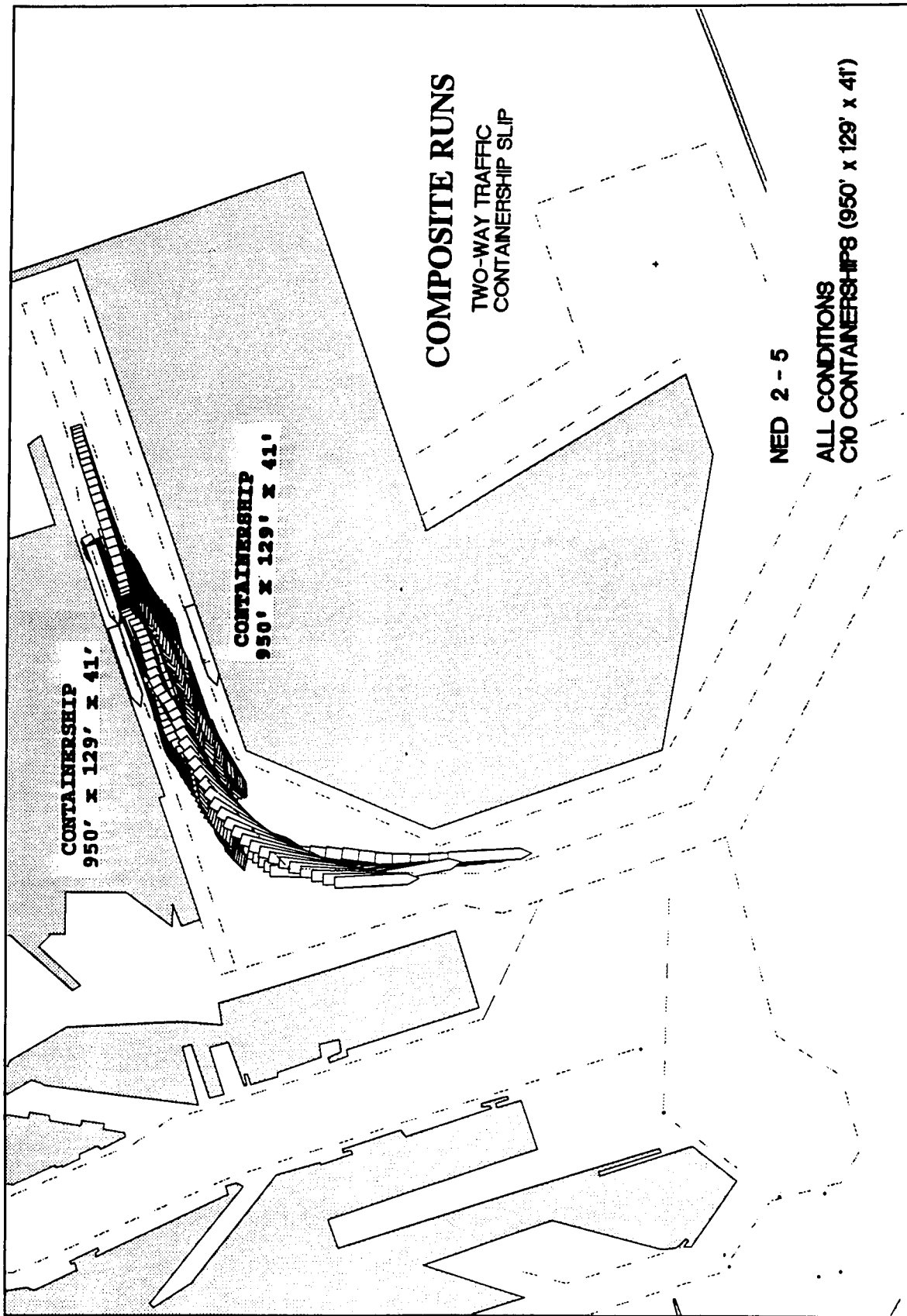
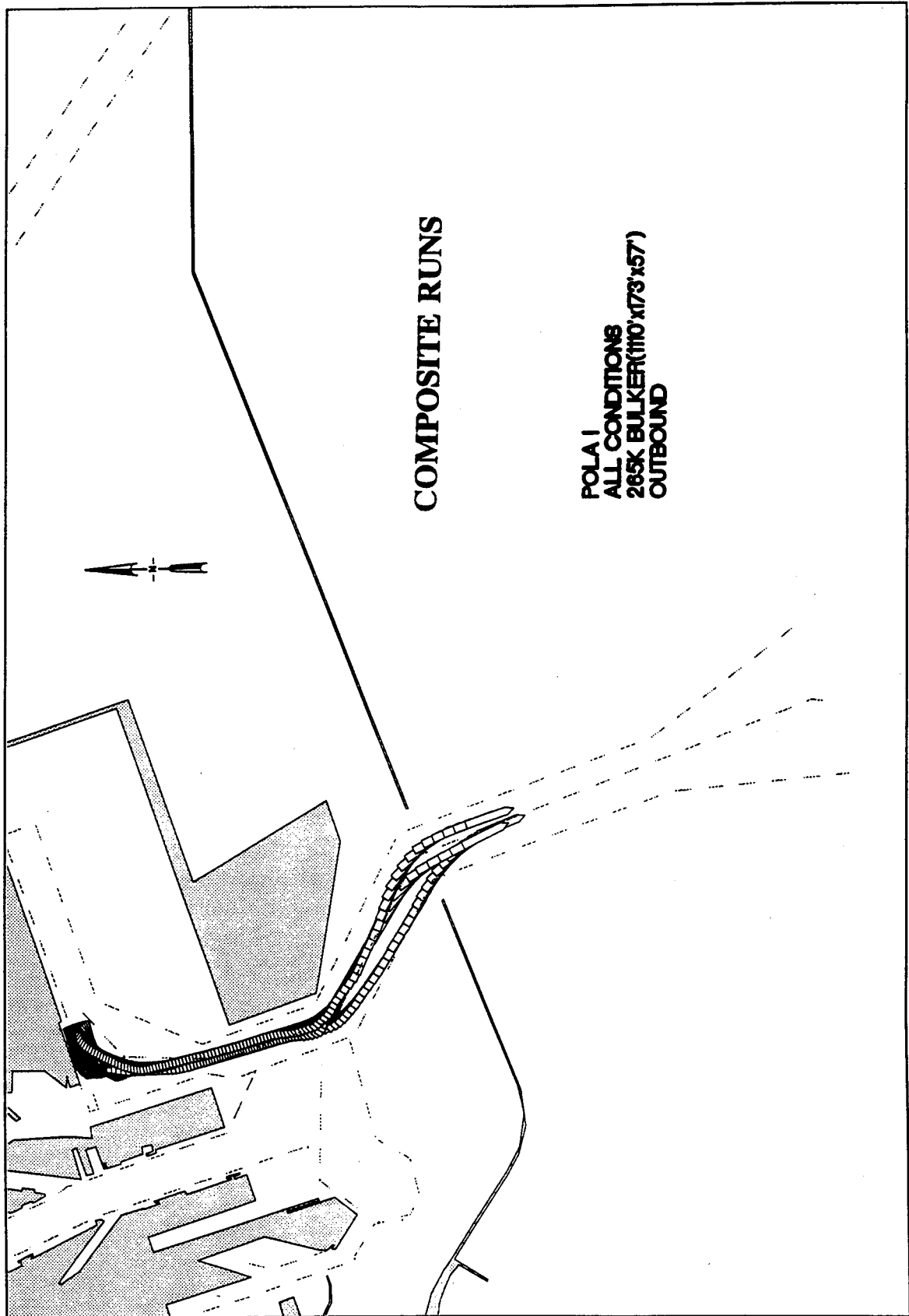

Plate 66



**COMPOSITE RUNS**

**POLA I  
ALL CONDITIONS  
285K BULKER(110'x173'x57')  
OUTBOUND**

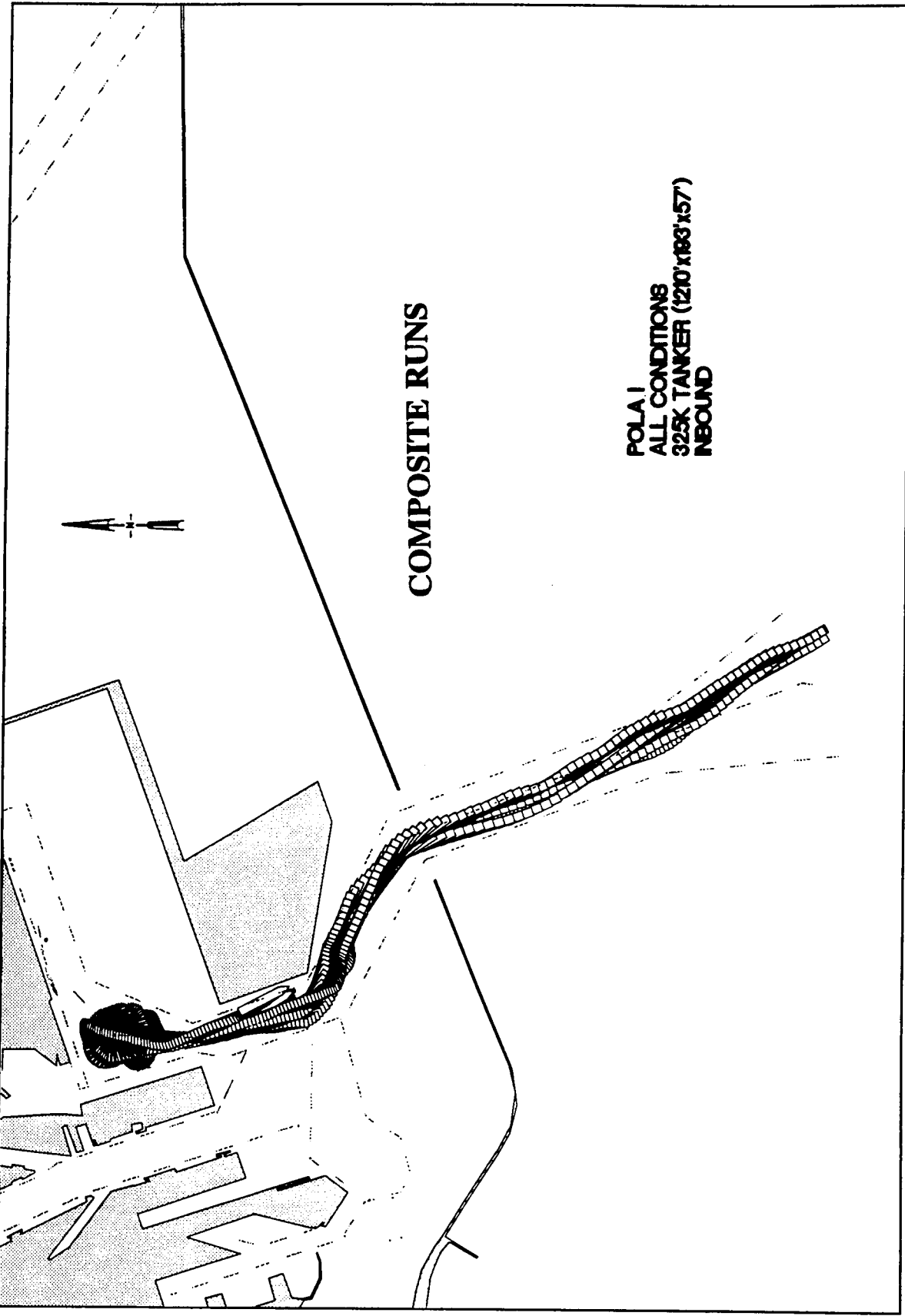

Plate 68

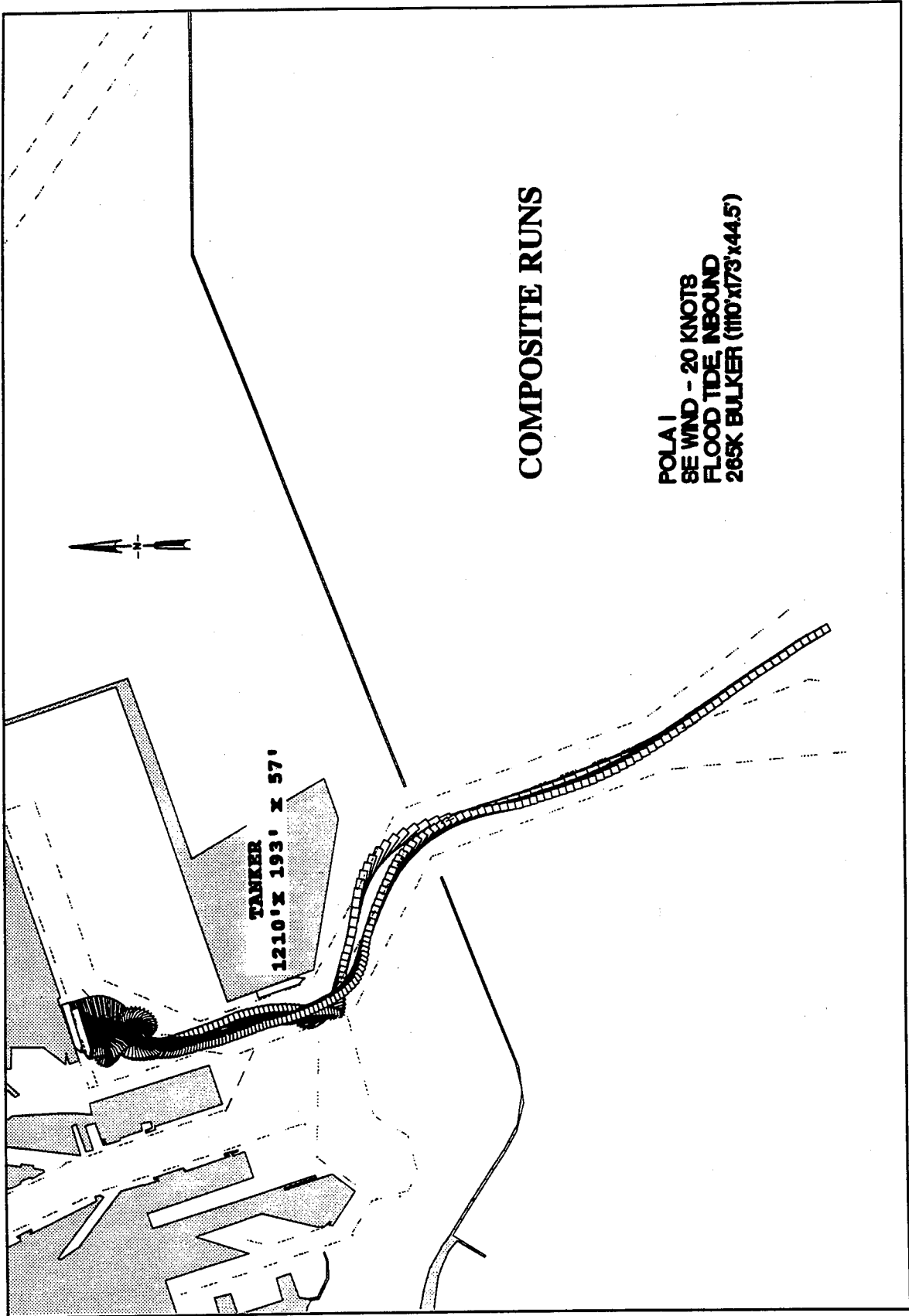
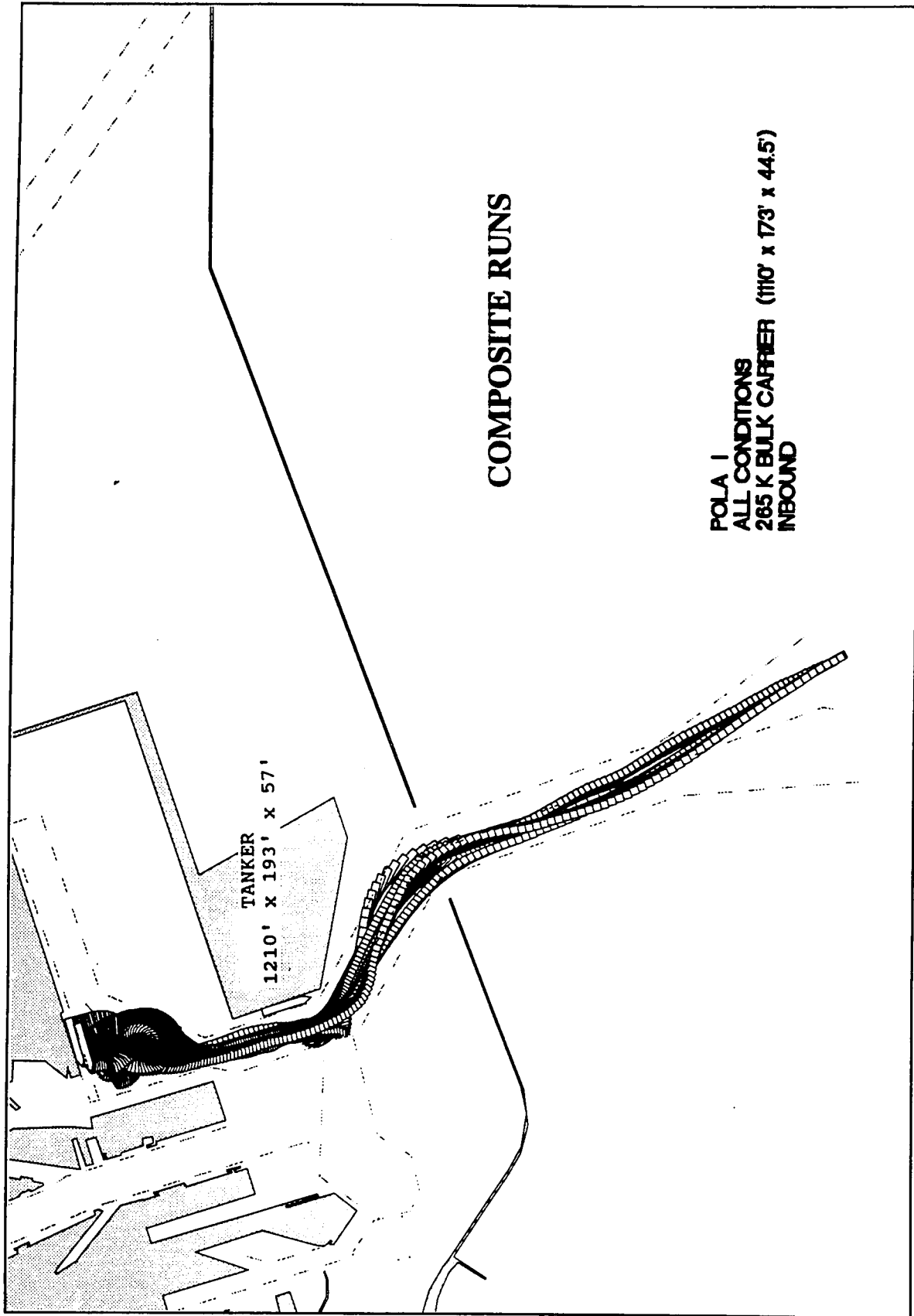

Plate 69



**COMPOSITE RUNS**

**POLA I  
ALL CONDITIONS  
265 K BULK CARRIER (1110' x 173' x 44.5)  
INBOUND**

**TANKER  
1210' x 193' x 57'**

Plate 70

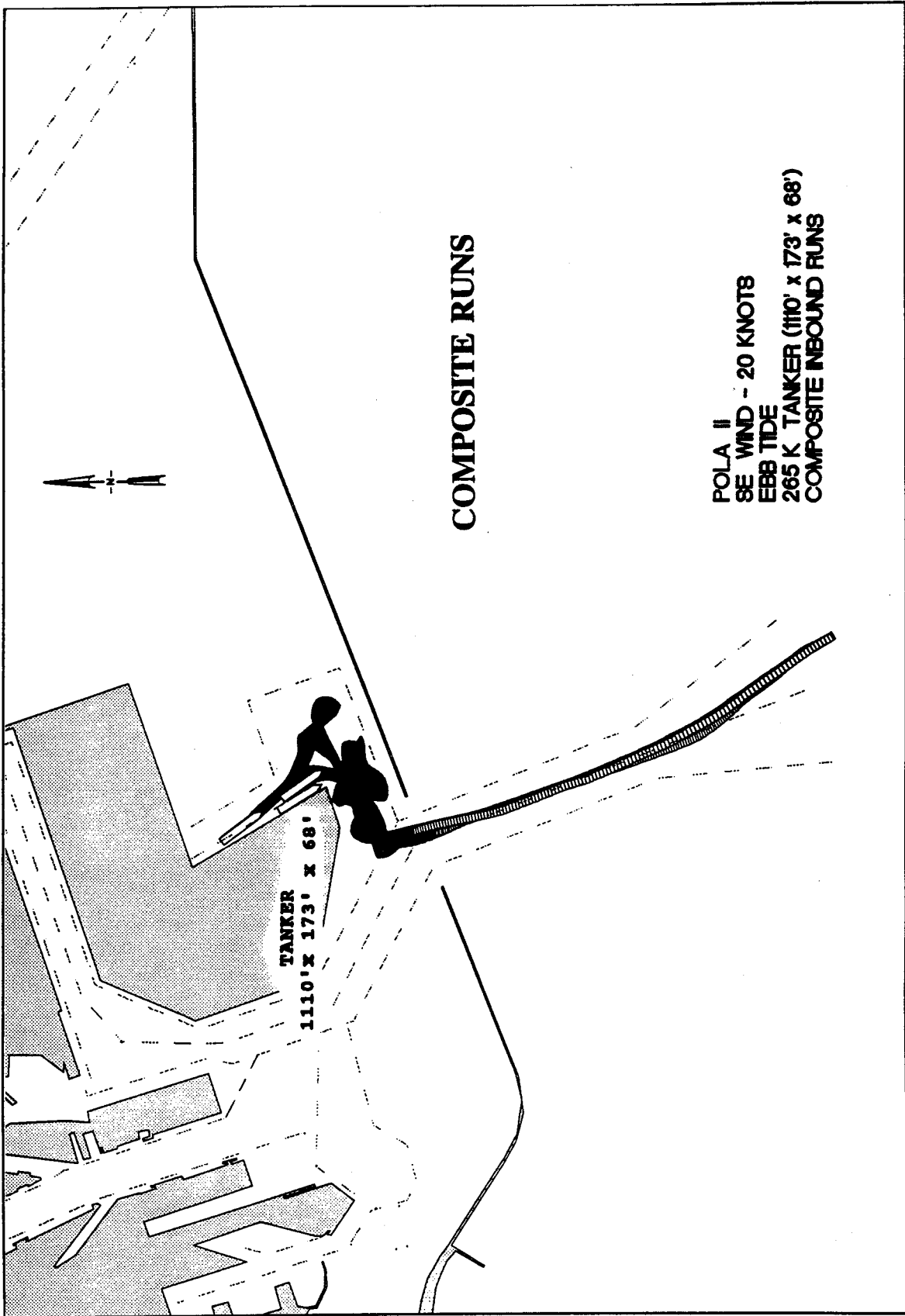

**COMPOSITE RUNS**

**POLA II  
SE WIND - 20 KNOTS  
EBB TIDE  
265 K TANKER (1110' X 173' X 68')  
COMPOSITE INBOUND RUNS**

**TANKER  
1110' X 173' X 68'**

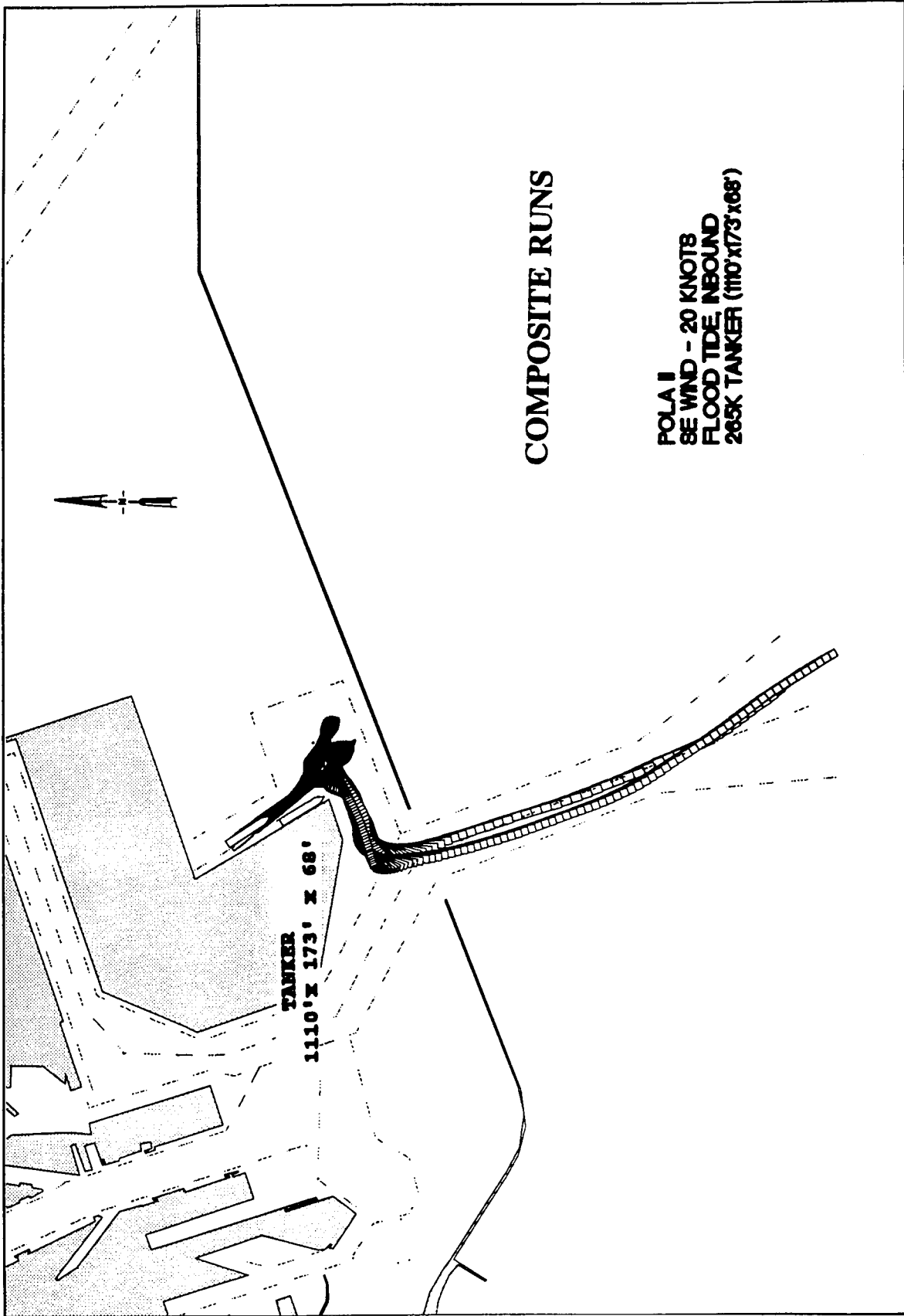
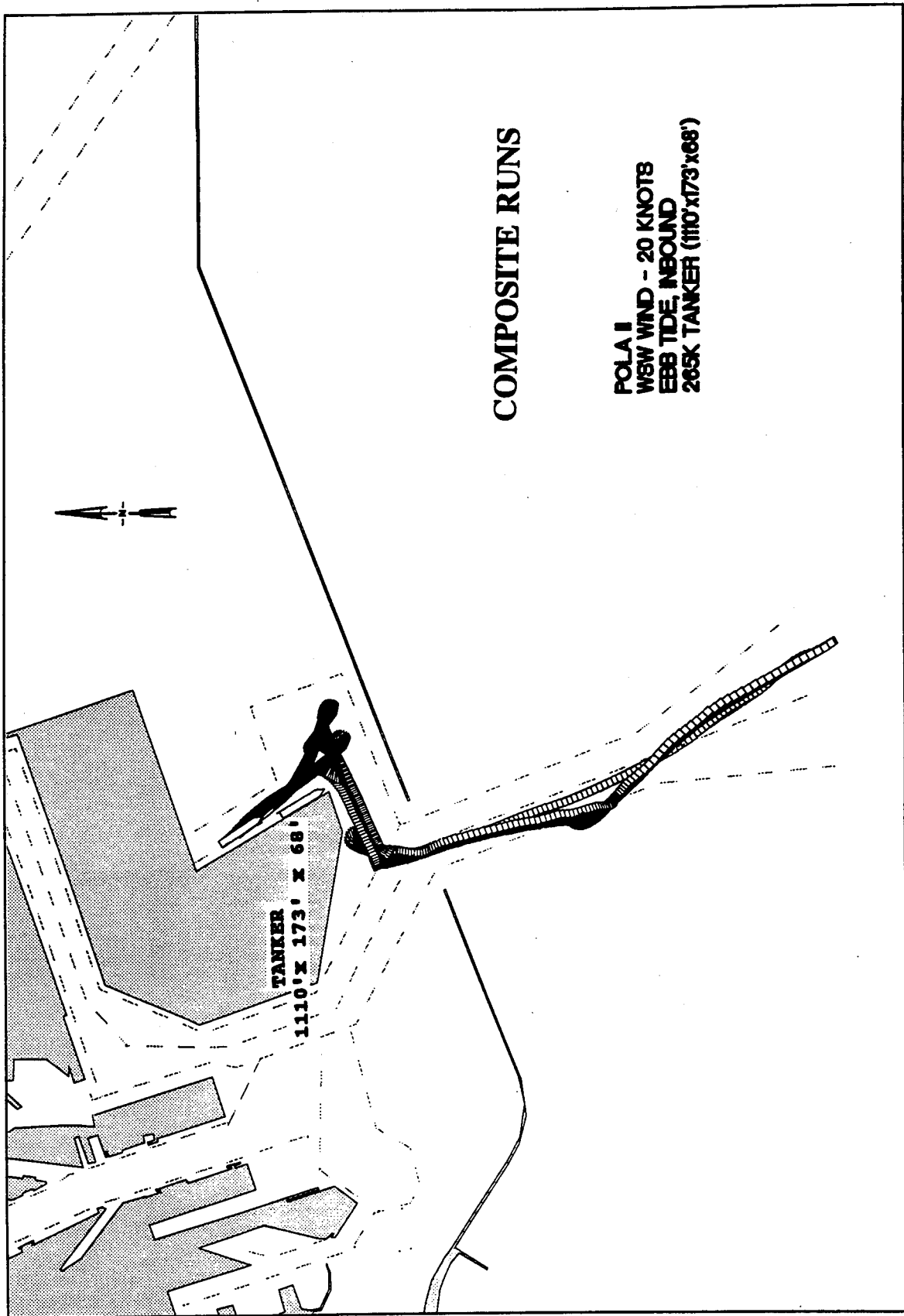
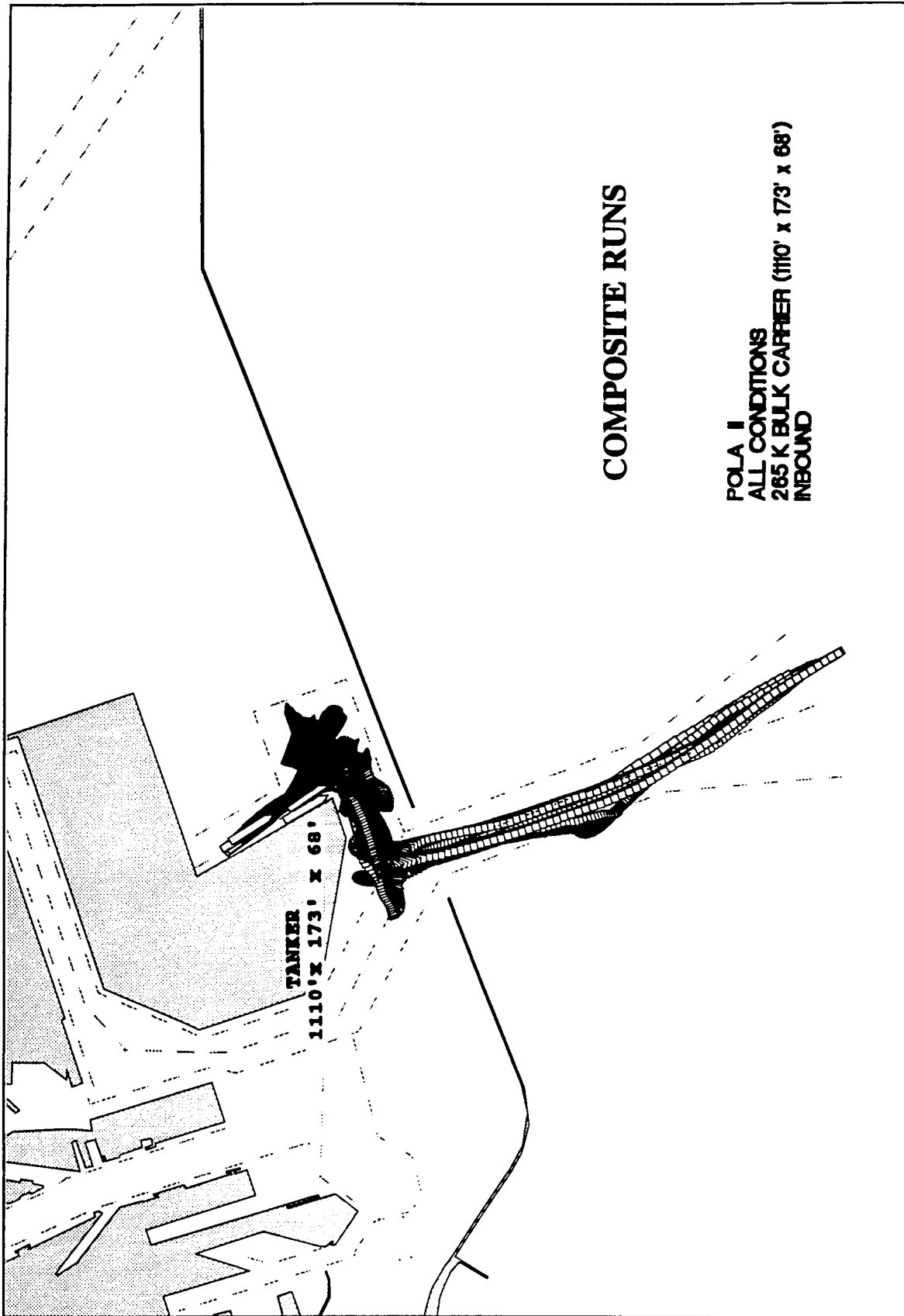

Plate 72





**COMPOSITE RUNS**

**POLA I  
ALL CONDITIONS  
265 K BULK CARRIER (110' x 173' x 68')  
INBOUND**

**TANKER  
1110' x 173' x 68'**

Plate 74

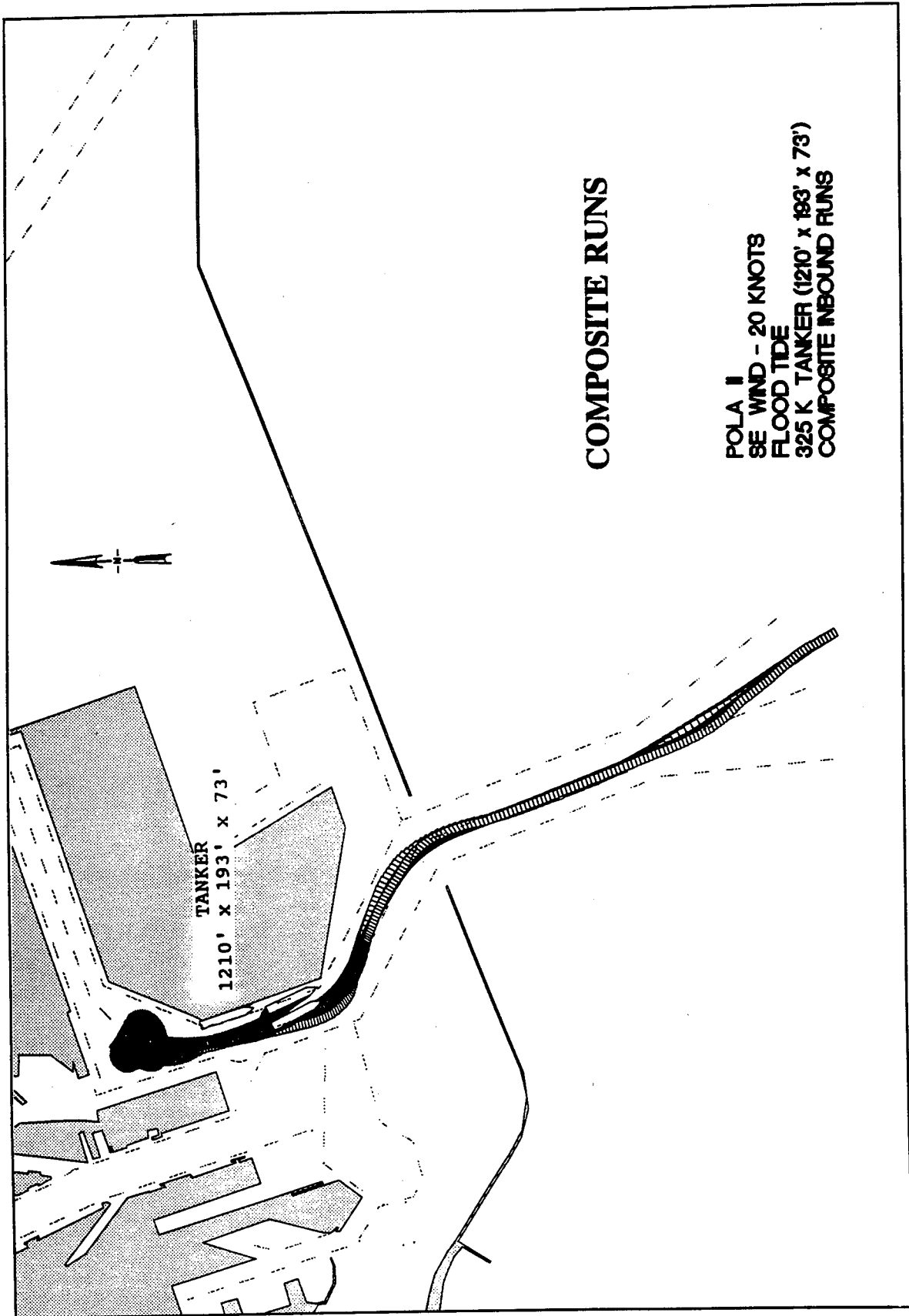

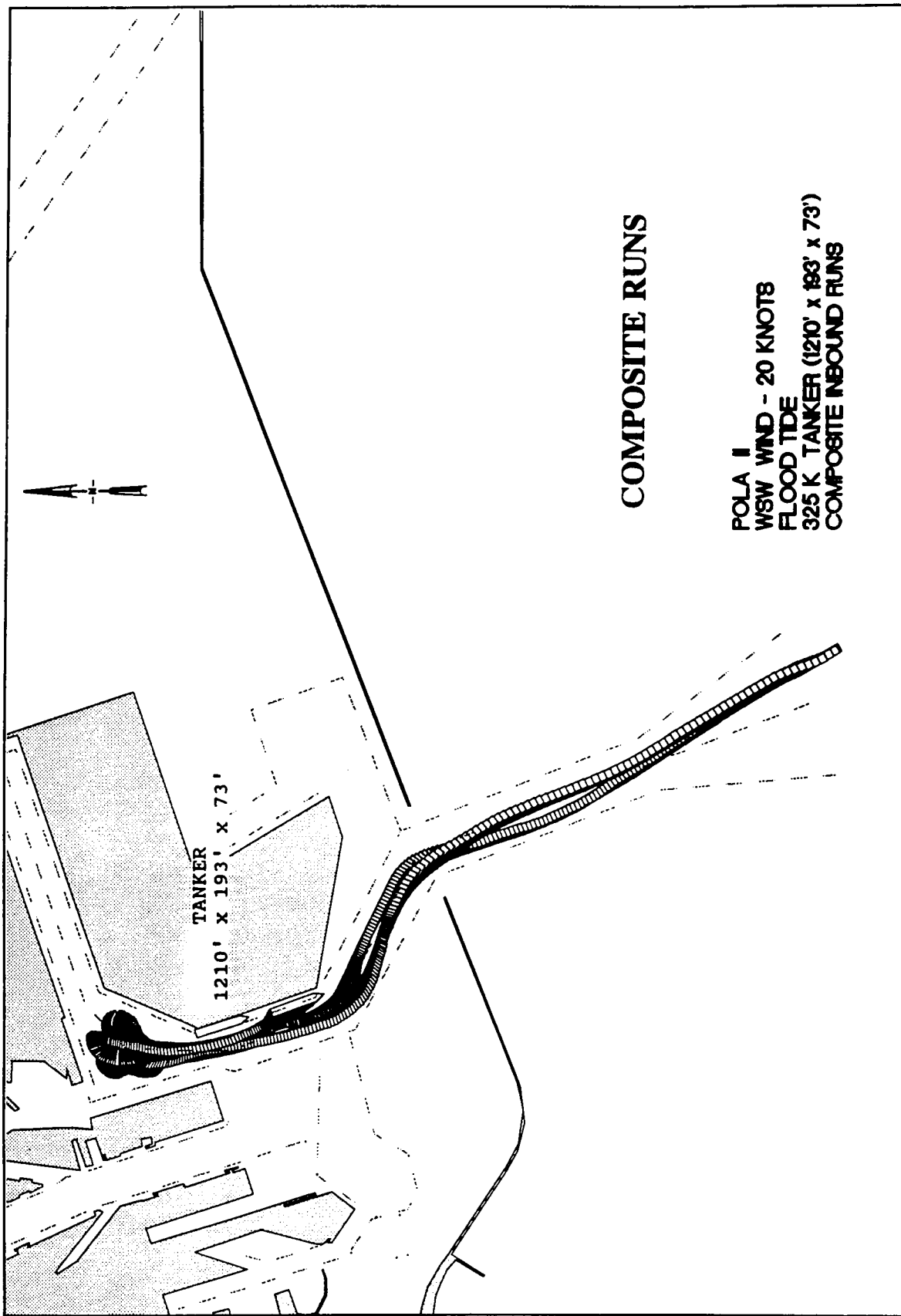
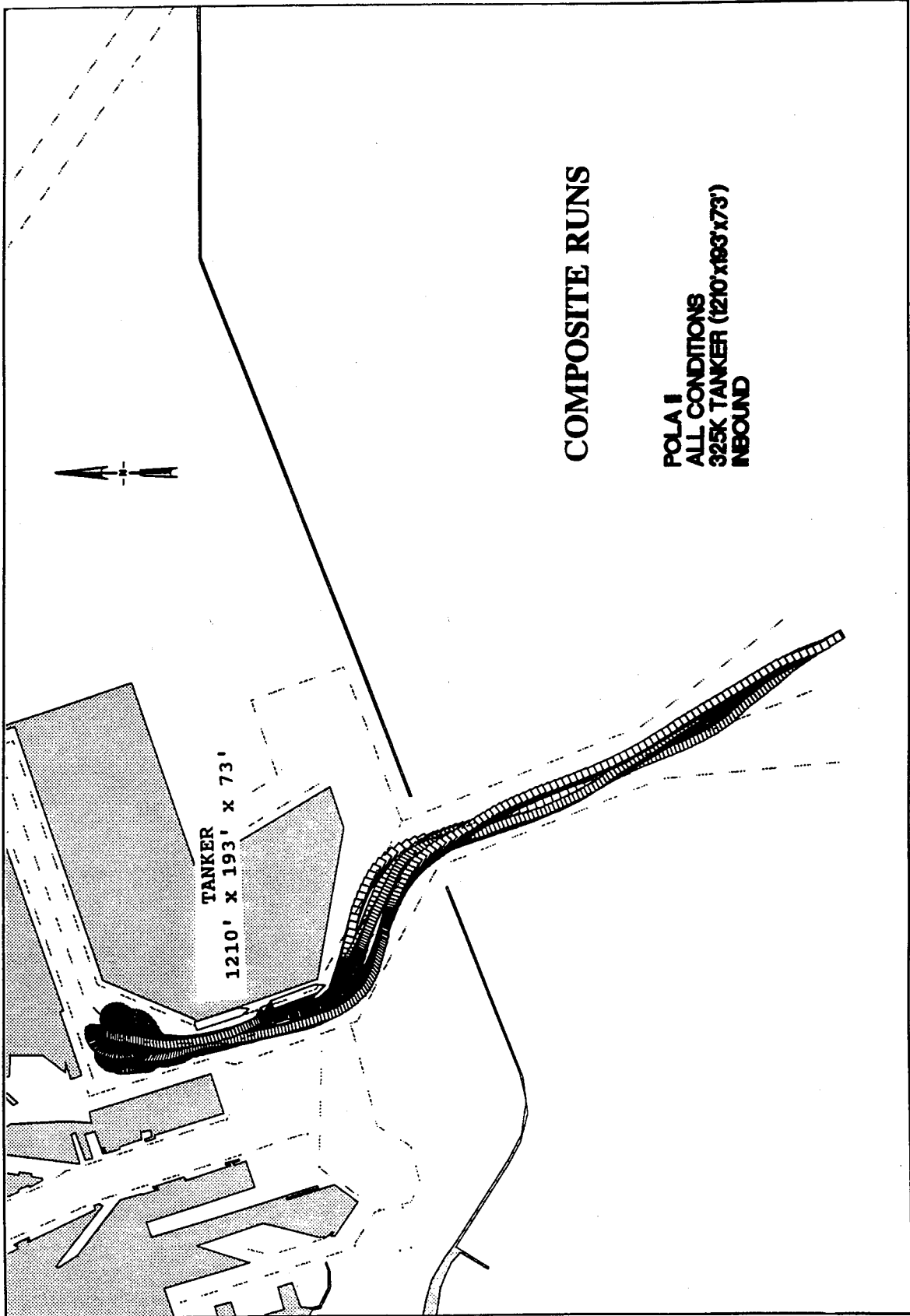

Plate 76



**COMPOSITE RUNS**

**POLA I  
ALL CONDITIONS  
325K TANKER (1210'x193'x73')  
INBOUND**

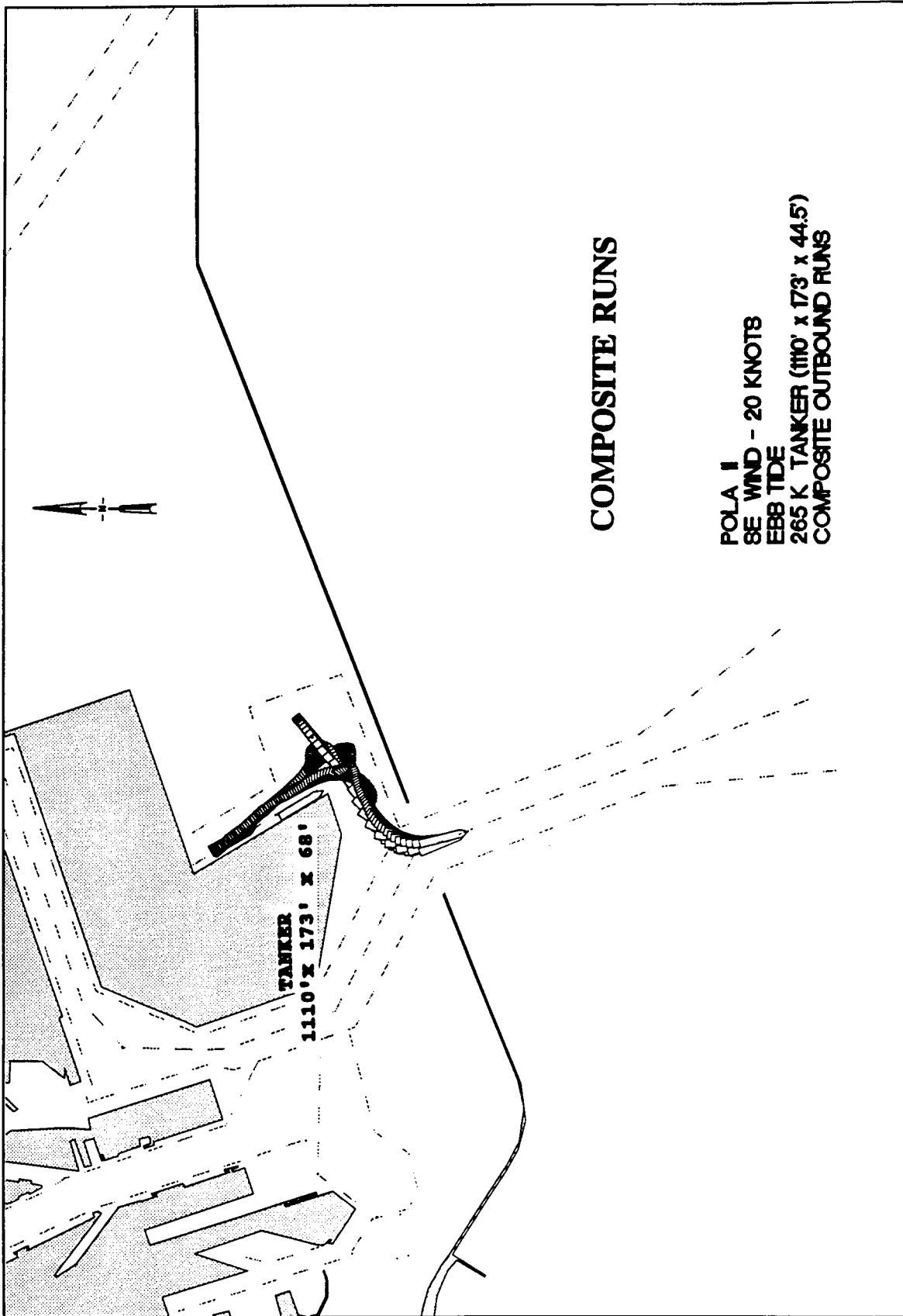
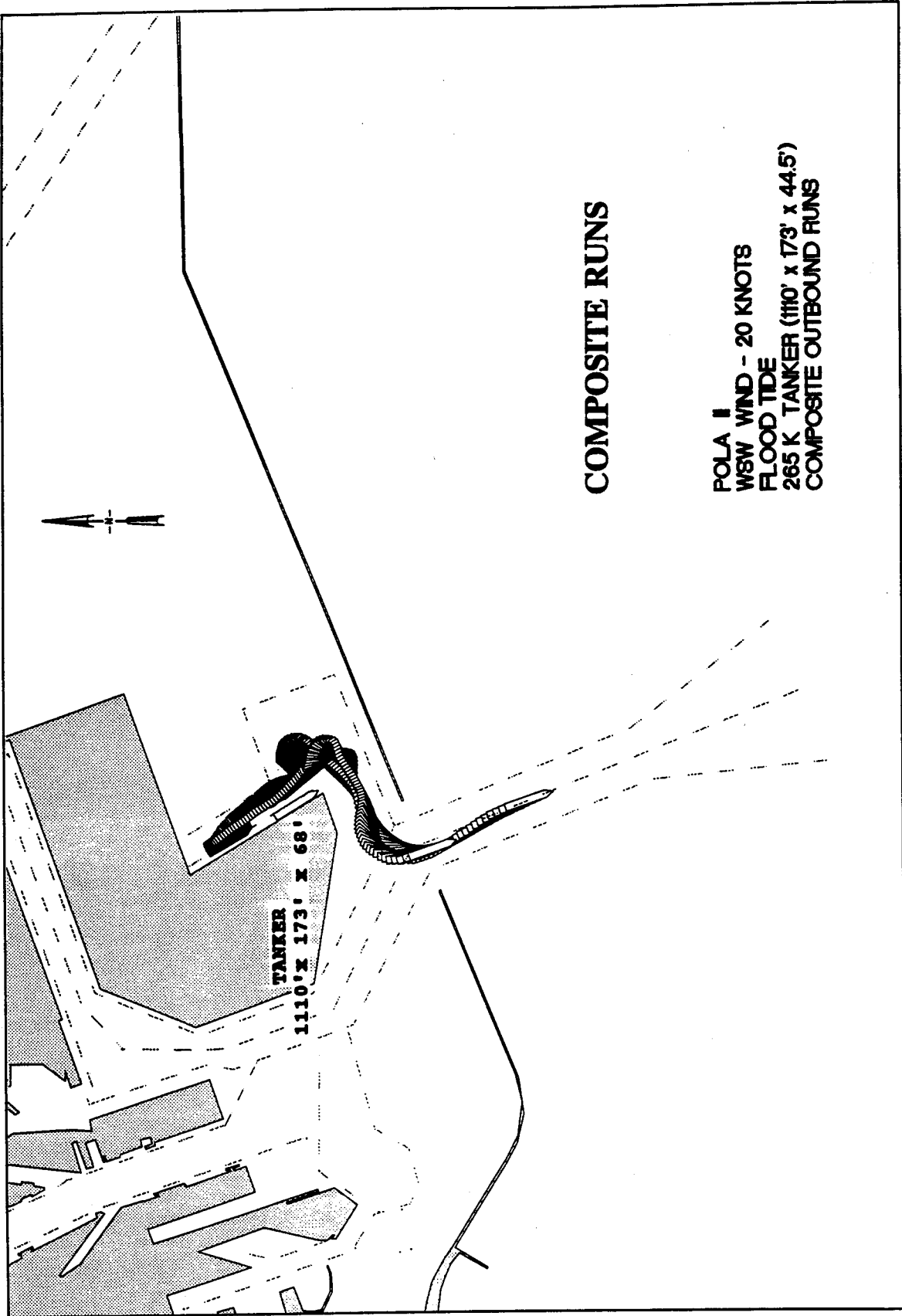
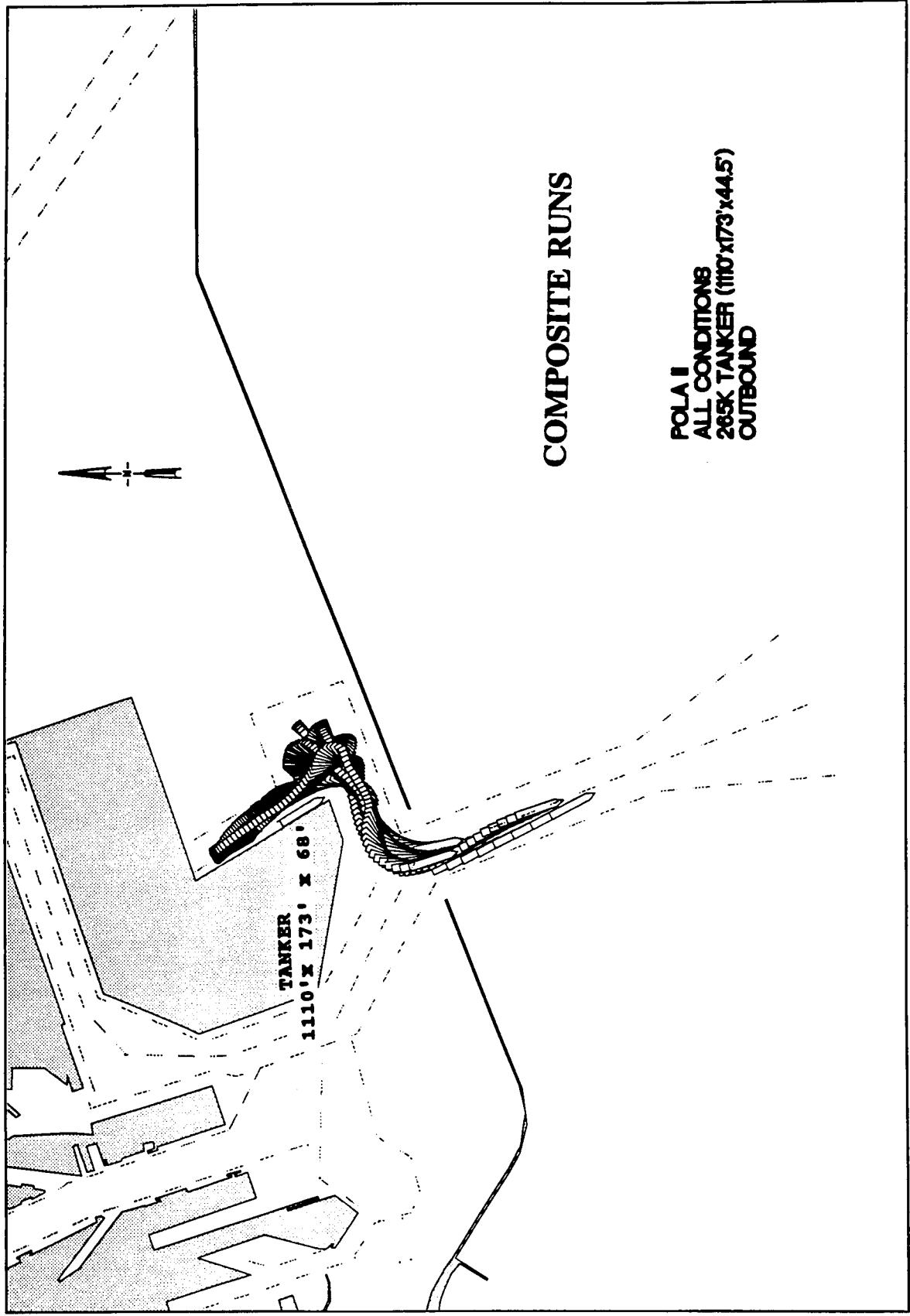

Plate 78



**COMPOSITE RUNS**

**POLA II  
WSW WIND - 20 KNOTS  
FLOOD TIDE  
265 K TANKER (1110' x 173' x 44.5')  
COMPOSITE OUTBOUND RUNS**



**COMPOSITE RUNS**

**FOLA II  
ALL CONDITIONS  
285K TANKER (1110'x173'x44.5')  
OUTBOUND**

Plate 80

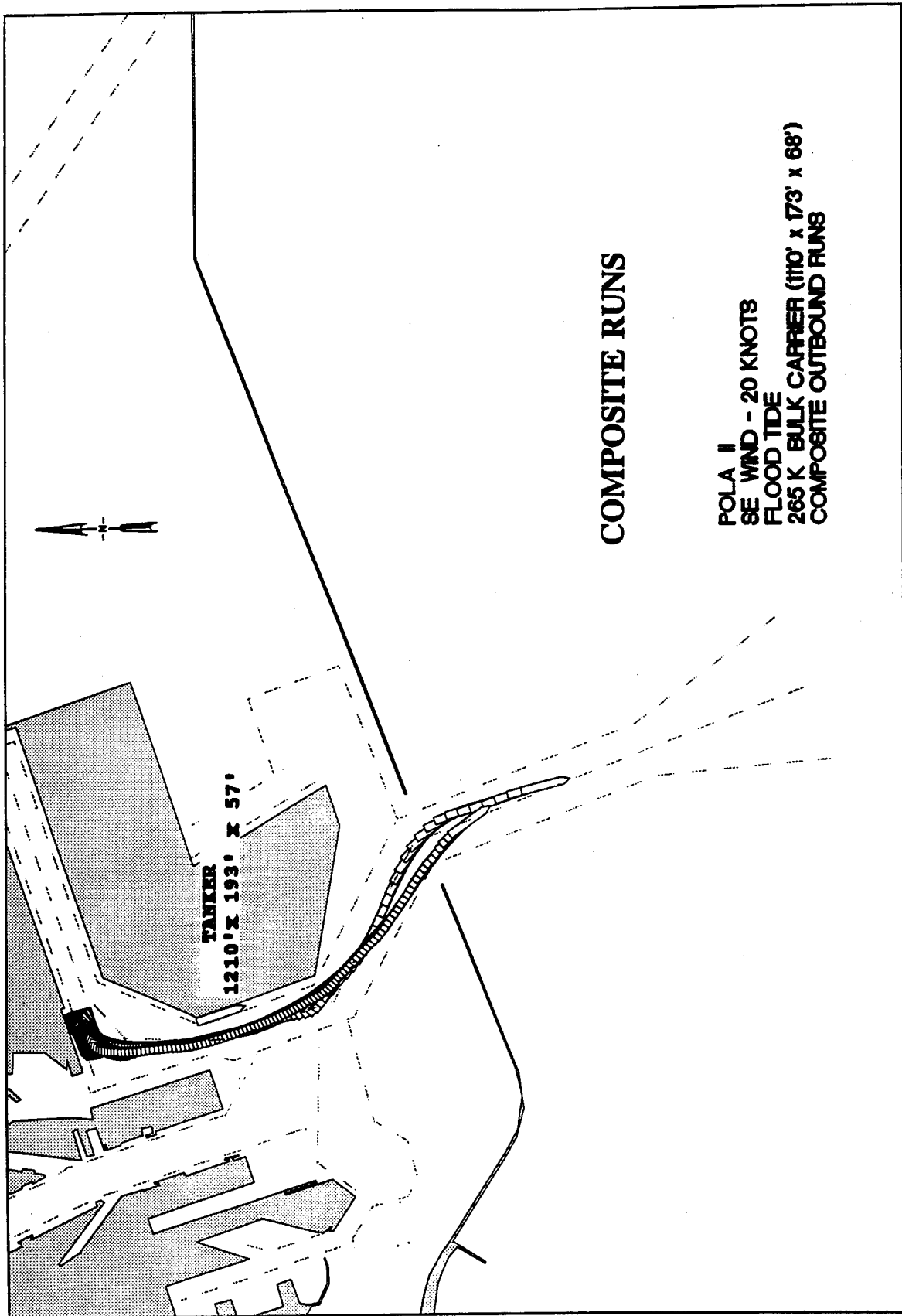

**COMPOSITE RUNS**

**POLA II  
SE WIND - 20 KNOTS  
FLOOD TIDE  
265 K BULK CARRIER (110' x 173' x 68')  
COMPOSITE OUTBOUND RUNS**

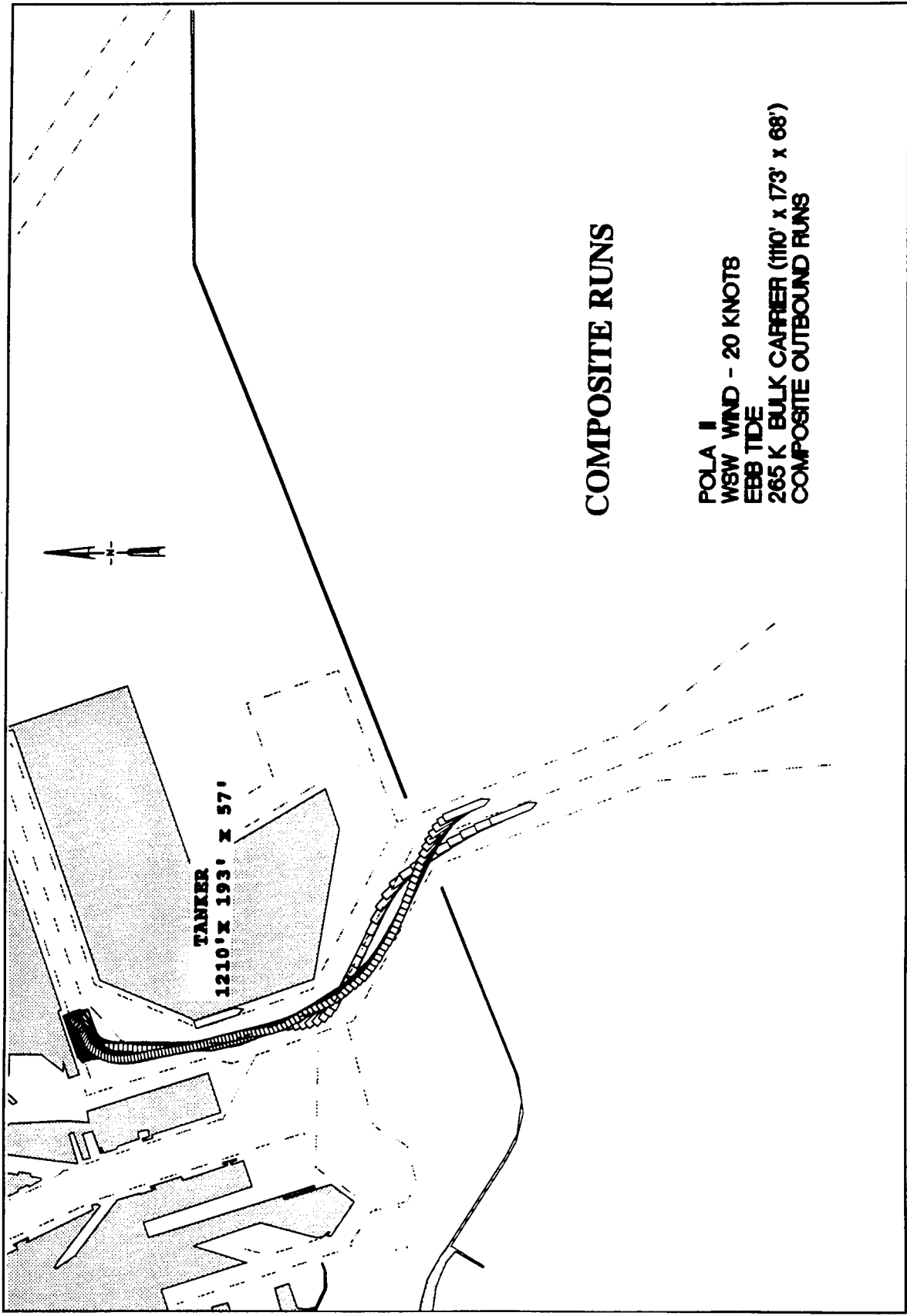

**COMPOSITE RUNS**

**POLA I  
WSW WIND - 20 KNOTS  
EBB TIDE  
265 K BULK CARRIER (1110' X 173' X 68')  
COMPOSITE OUTBOUND RUNS**

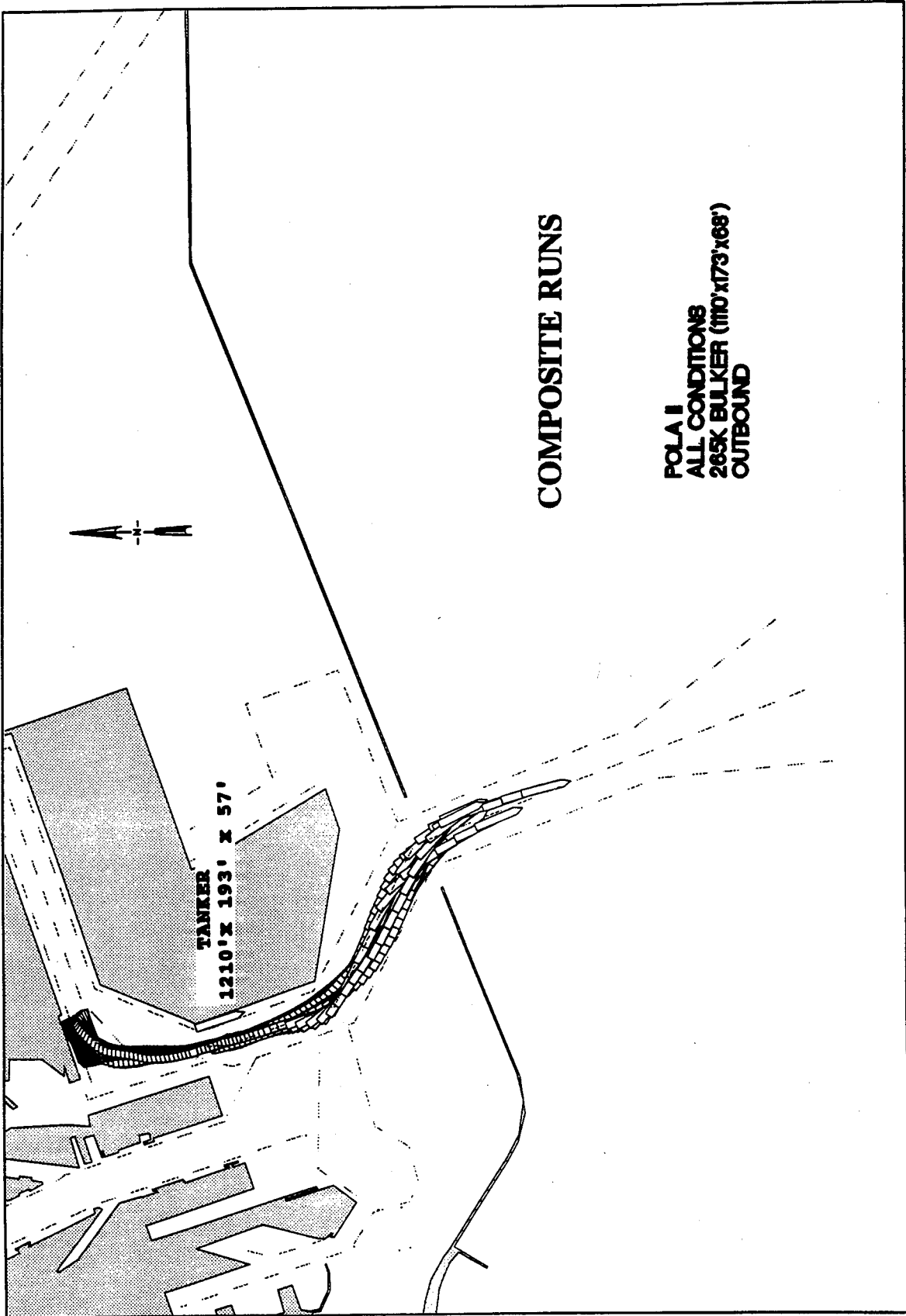

**COMPOSITE RUNS**

**POLA I  
ALL CONDITIONS  
265K BULKER (110' X 173' X 68')  
OUTBOUND**

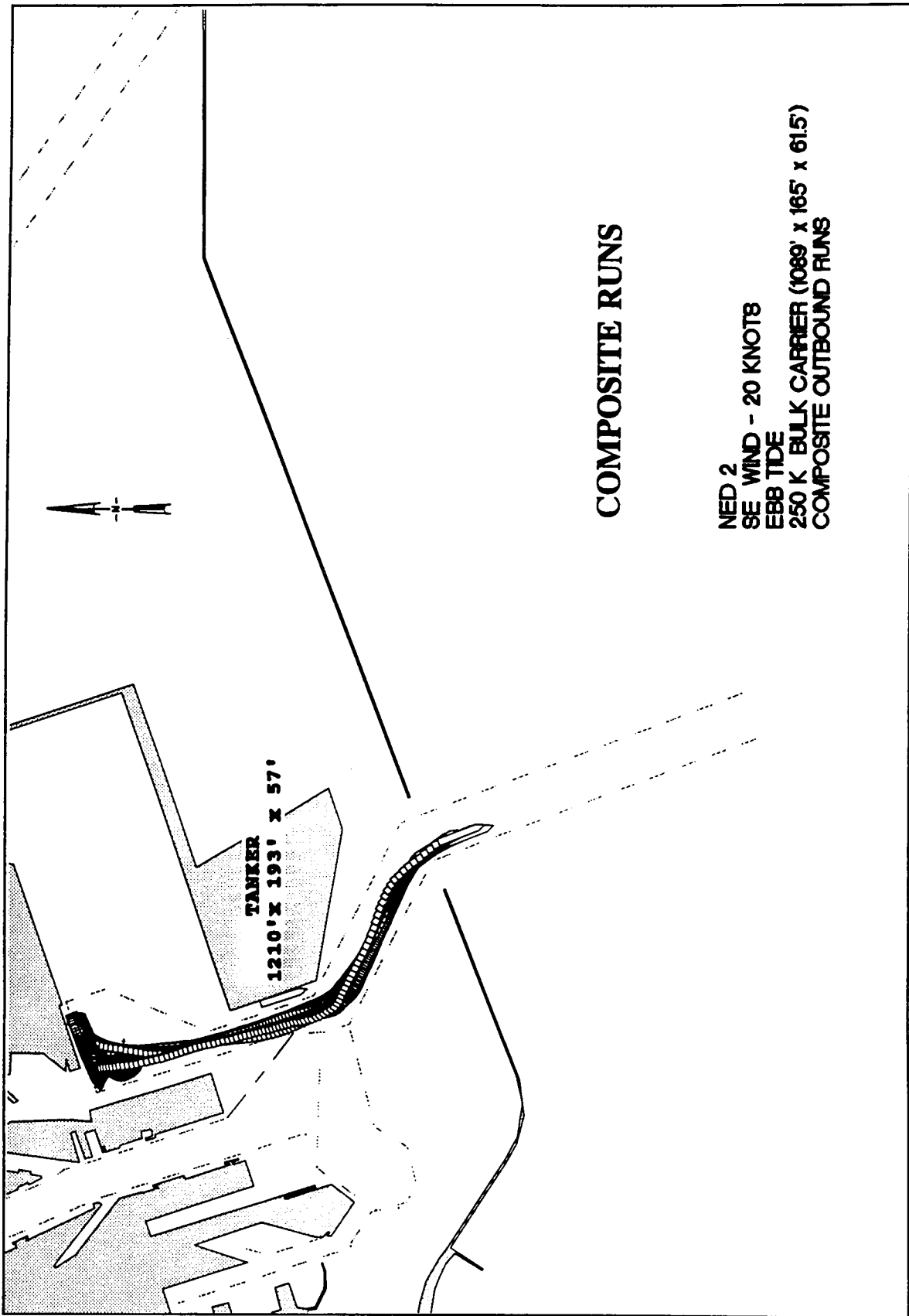

**COMPOSITE RUNS**

NED 2  
SE WIND - 20 KNOTS  
EBB TIDE  
250 K BULK CARRIER (1089' x 165' x 61.5')  
COMPOSITE OUTBOUND RUNS

Plate 84

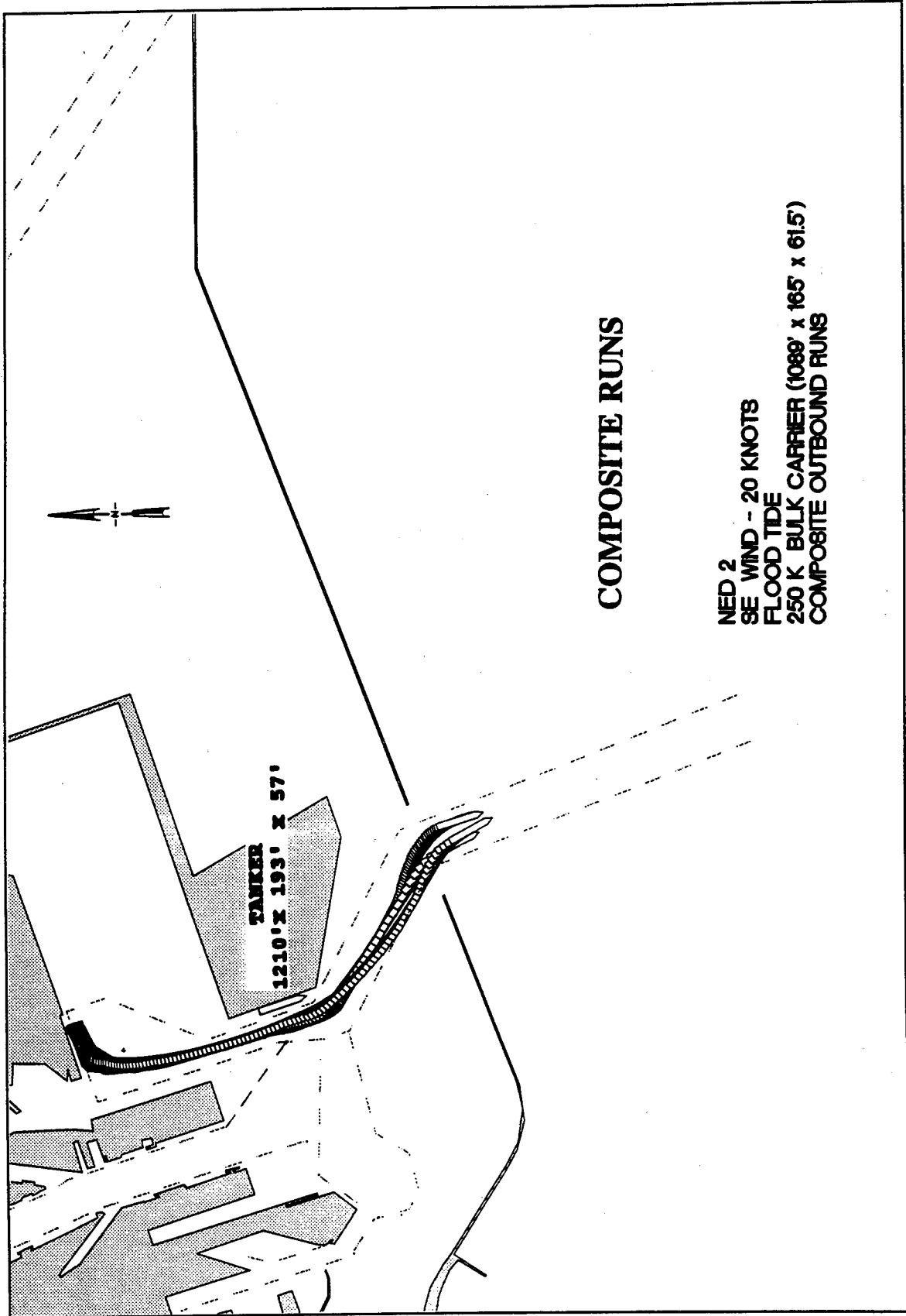

**COMPOSITE RUNS**

**NED 2  
SE WIND - 20 KNOTS  
FLOOD TIDE  
250 K BULK CARRIER (1089' x 165' x 61.5')  
COMPOSITE OUTBOUND RUNS**

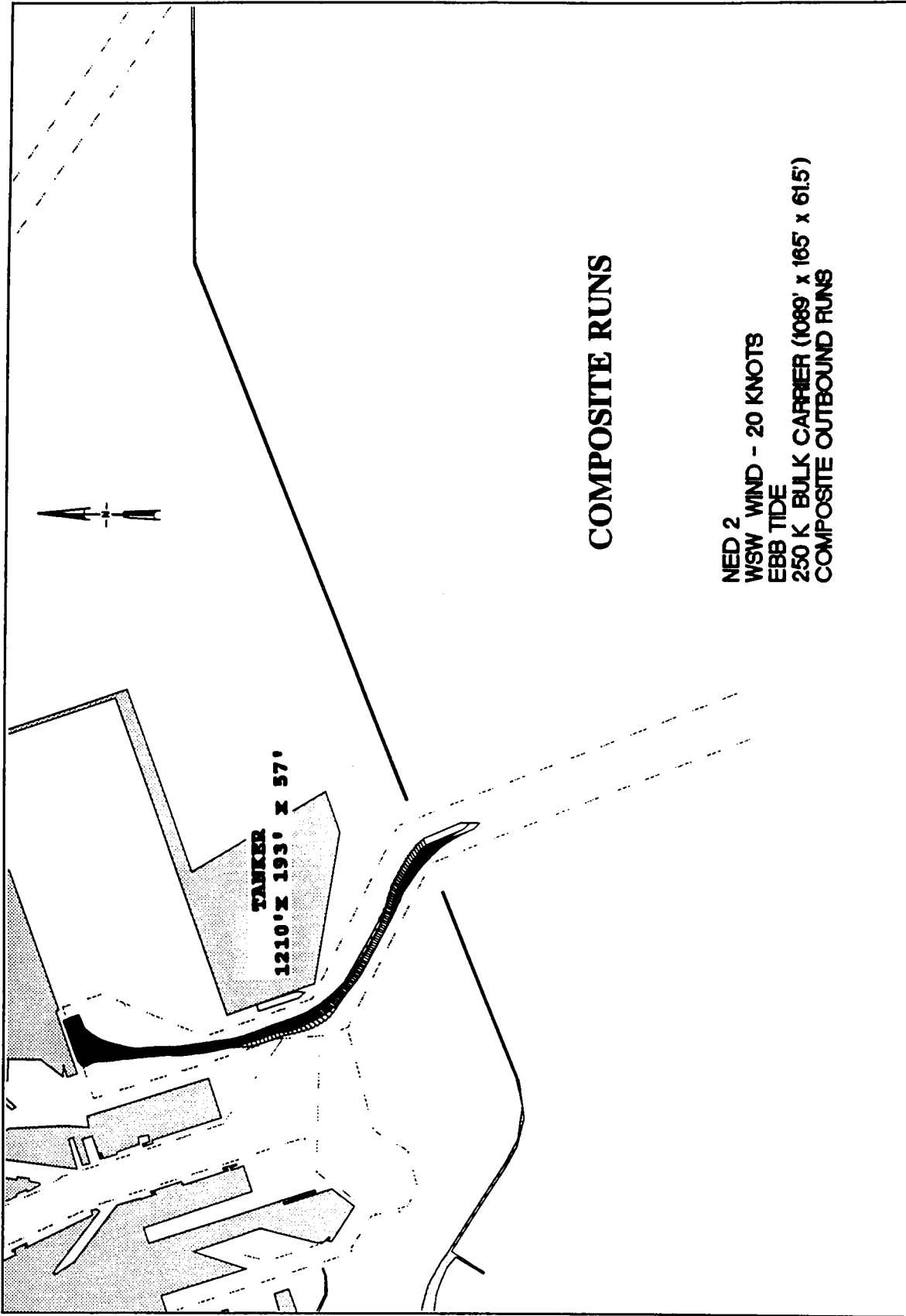
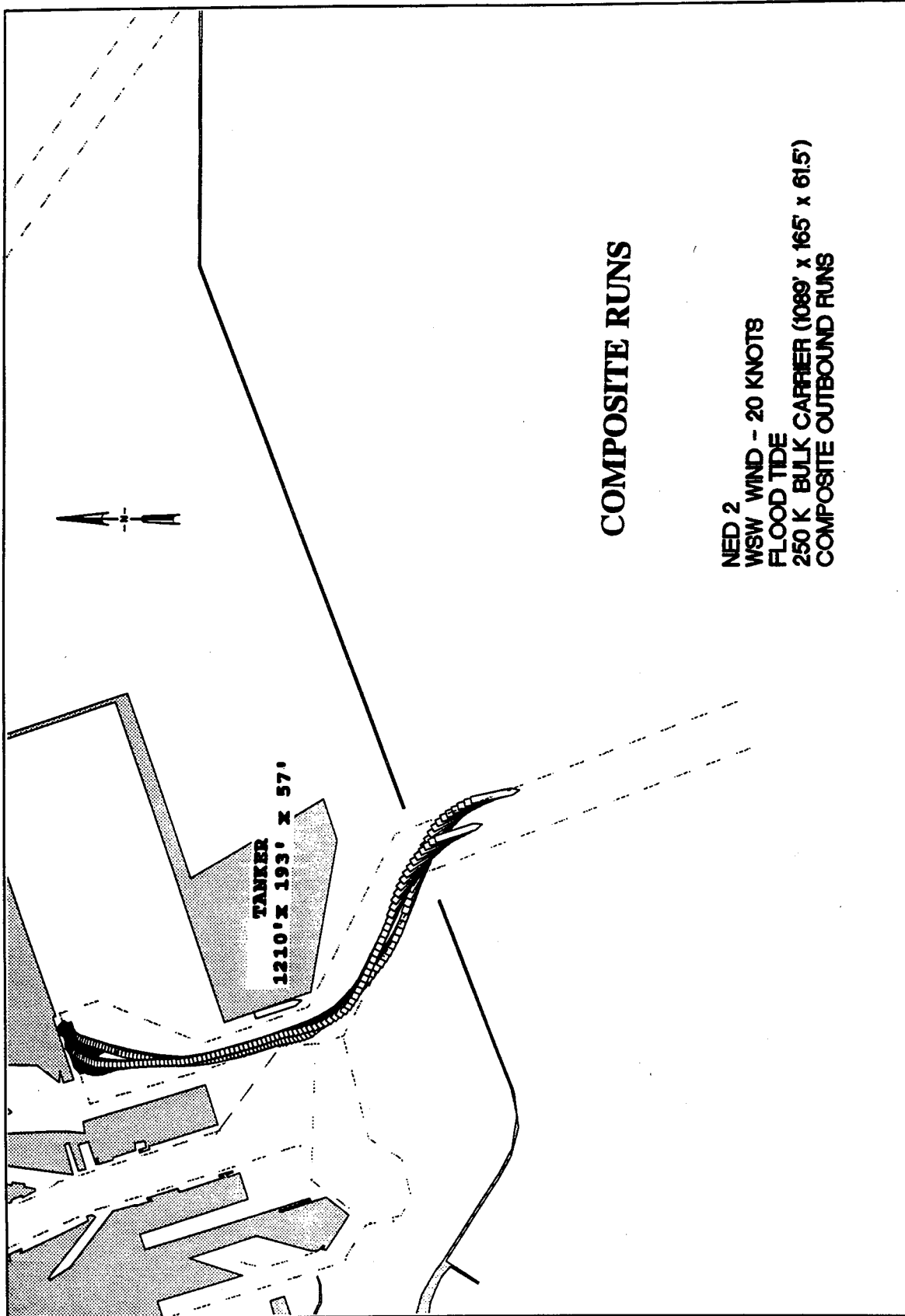
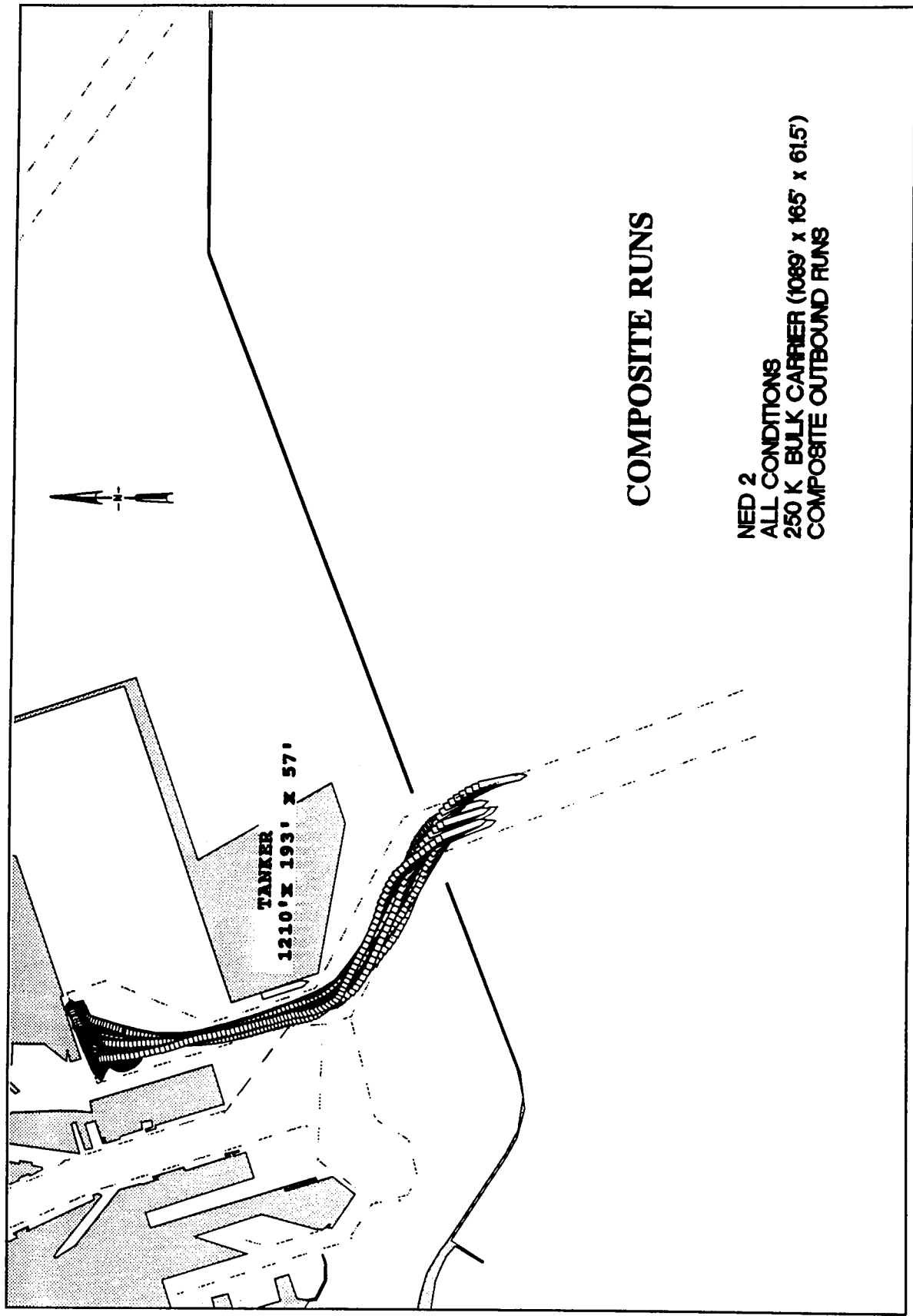

Plate 86



### COMPOSITE RUNS

NED 2  
WSW WIND - 20 KNOTS  
FLOOD TIDE  
250 K BULK CARRIER (1089' X 165' X 61.5')  
COMPOSITE OUTBOUND RUNS



### COMPOSITE RUNS

NED 2  
ALL CONDITIONS  
250 K BULK CARRIER (1089' x 165' x 61.5')  
COMPOSITE OUTBOUND RUNS

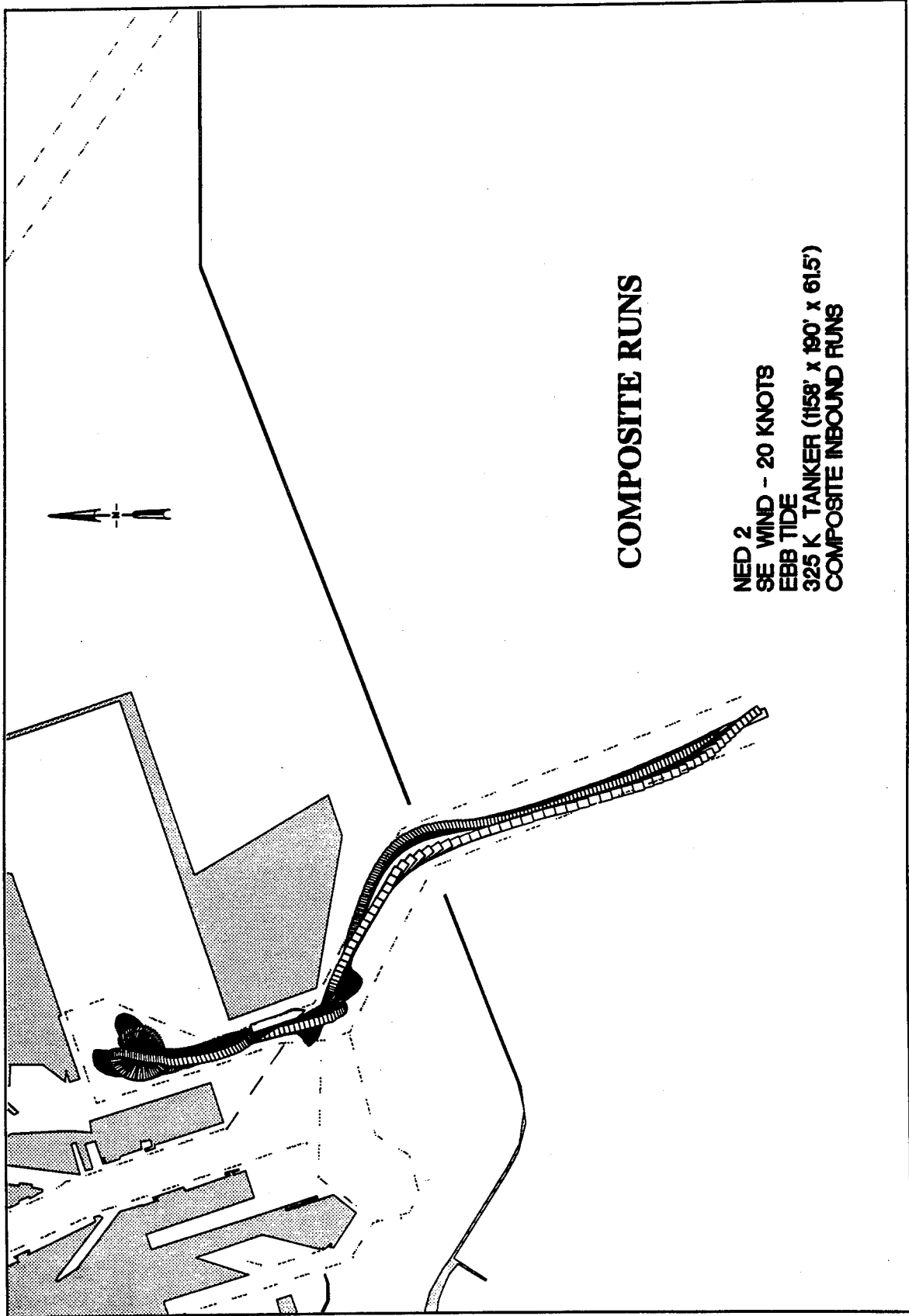

**COMPOSITE RUNS**

**NED 2  
SE WIND - 20 KNOTS  
EBB TIDE  
325 K TANKER (1158' x 190' x 61.5')  
COMPOSITE INBOUND RUNS**

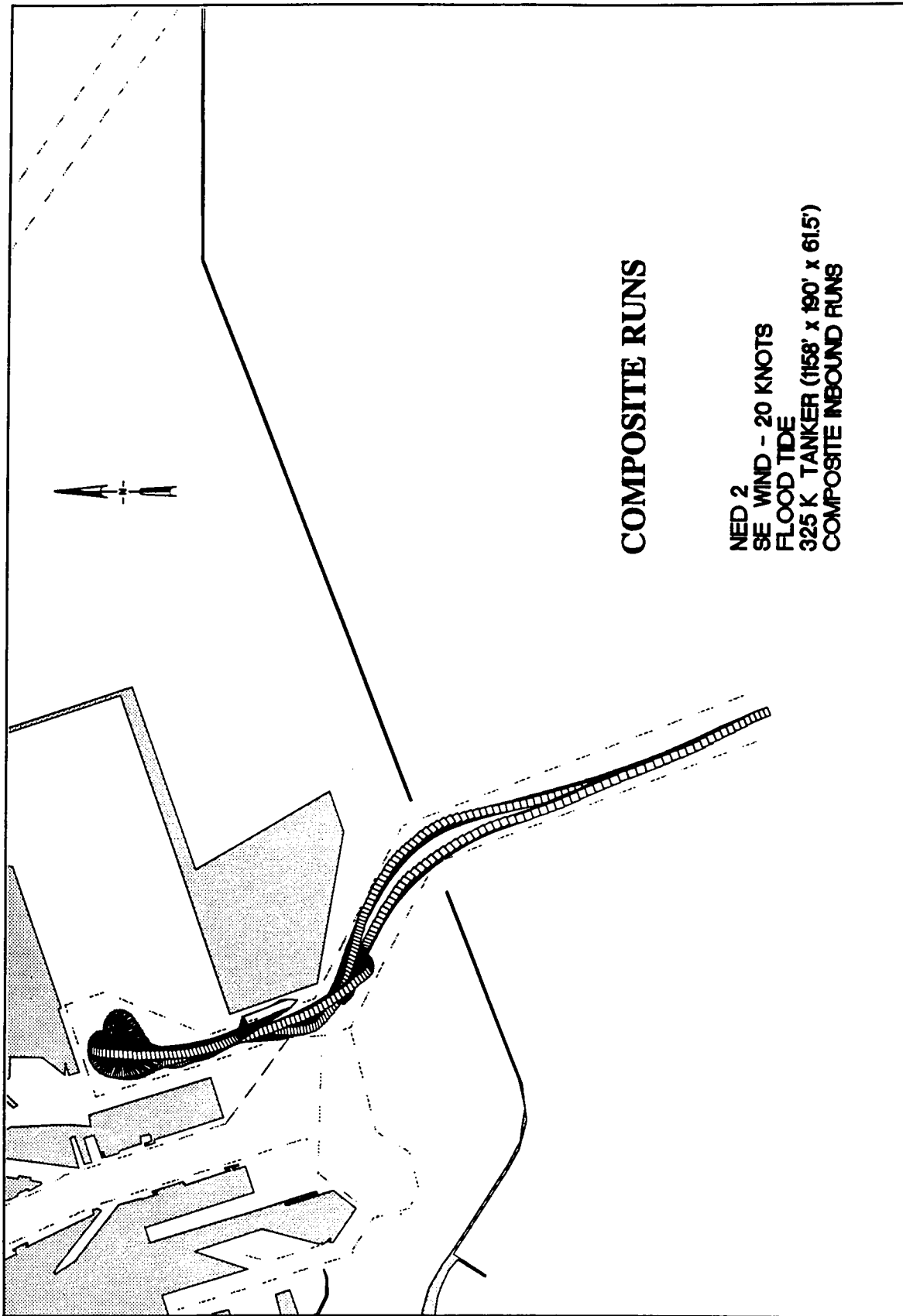

**COMPOSITE RUNS**

NED 2  
SE WIND - 20 KNOTS  
FLOOD TIDE  
325 K TANKER (158' x 190' x 61.5')  
COMPOSITE INBOUND RUNS

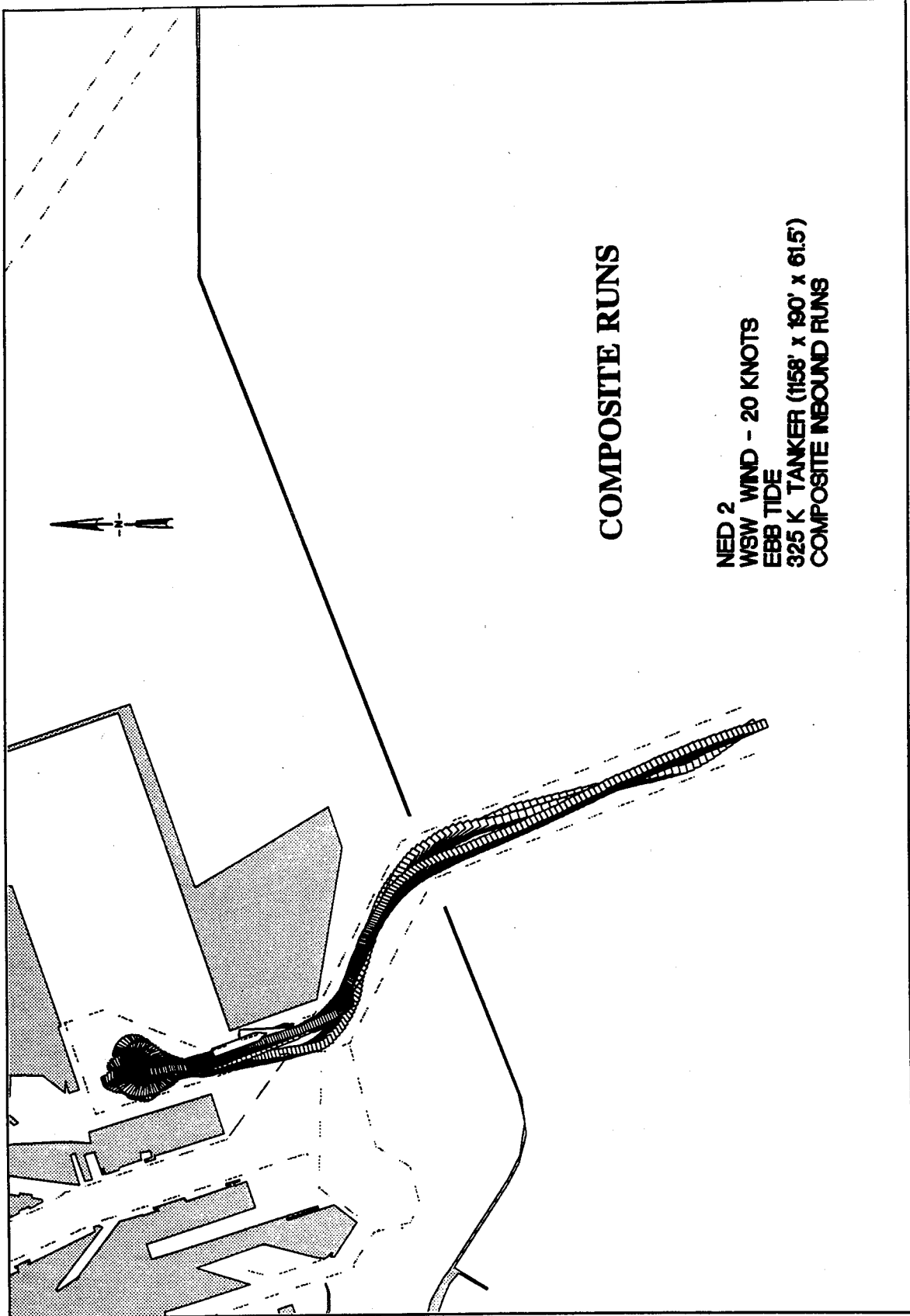

**COMPOSITE RUNS**

**NED 2  
WSW WIND - 20 KNOTS  
EBB TIDE  
325 K TANKER (1158' x 190' x 61.5')  
COMPOSITE INBOUND RUNS**

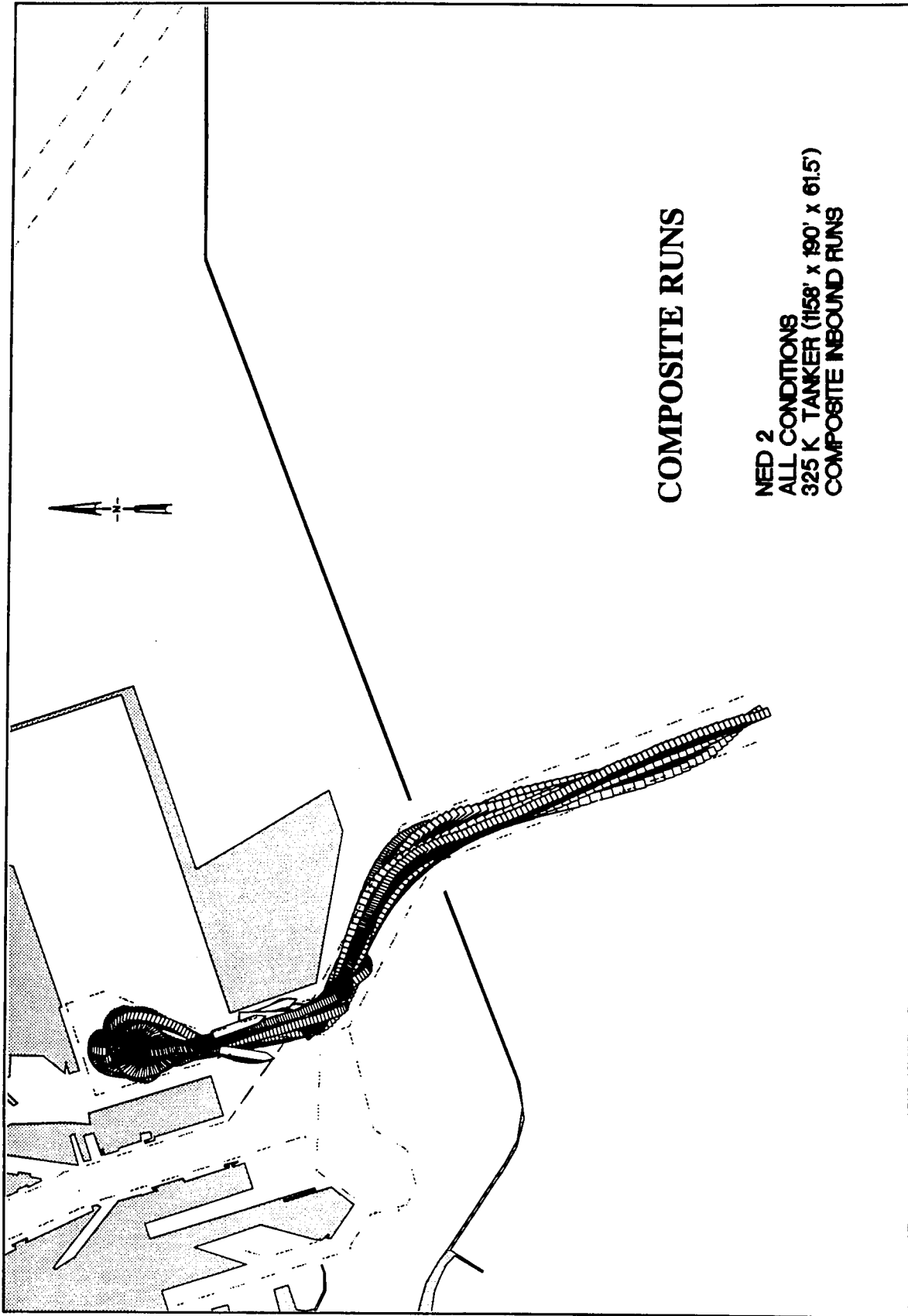

**COMPOSITE RUNS**

**NEED 2  
ALL CONDITIONS  
325 K TANKER (1158' x 190' x 61.5')  
COMPOSITE INBOUND RUNS**

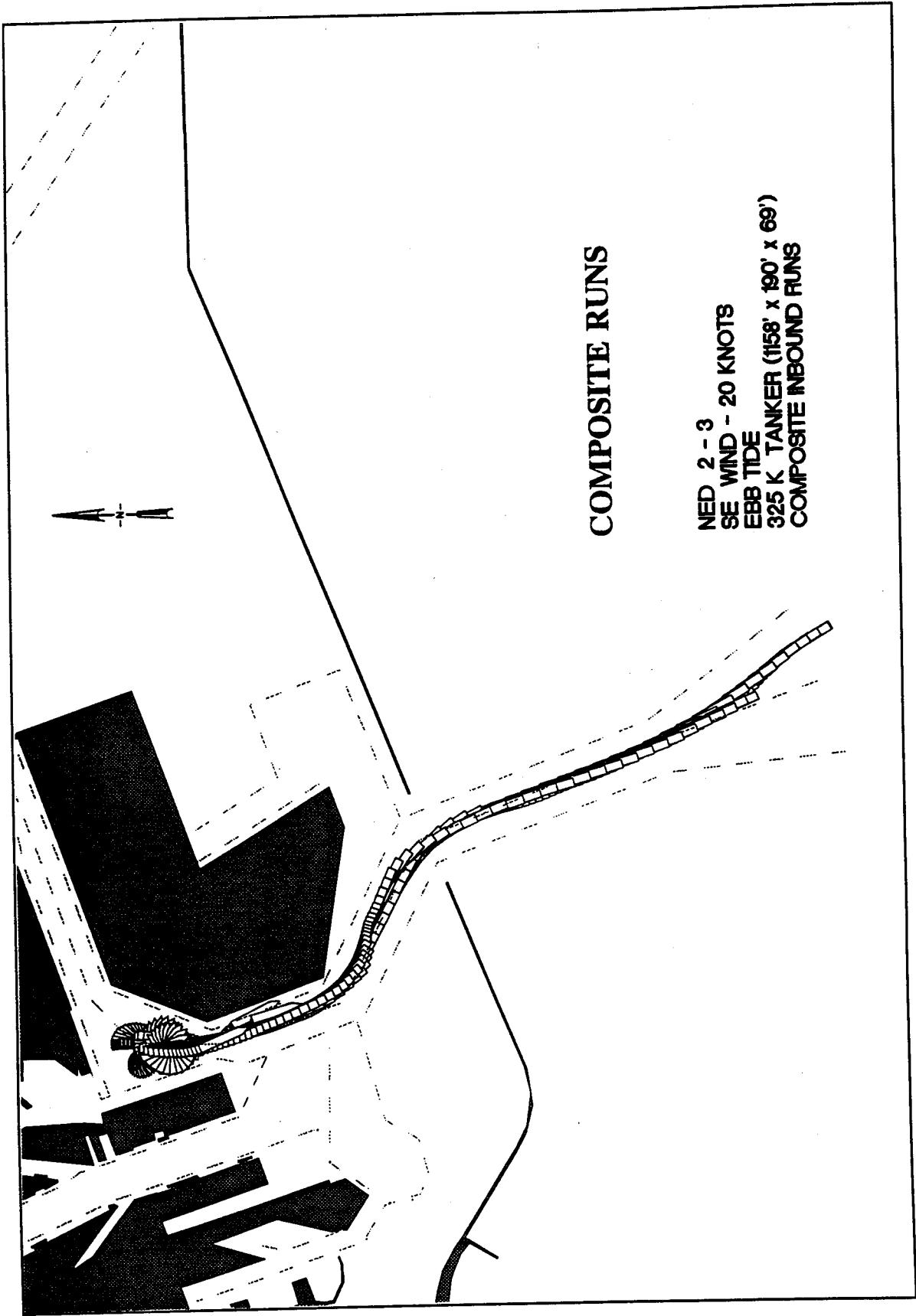

**COMPOSITE RUNS**

**NED 2-3  
SE WIND - 20 KNOTS  
EBB TIDE  
325 K TANKER (1158' x 190' x 69')  
COMPOSITE INBOUND RUNS**

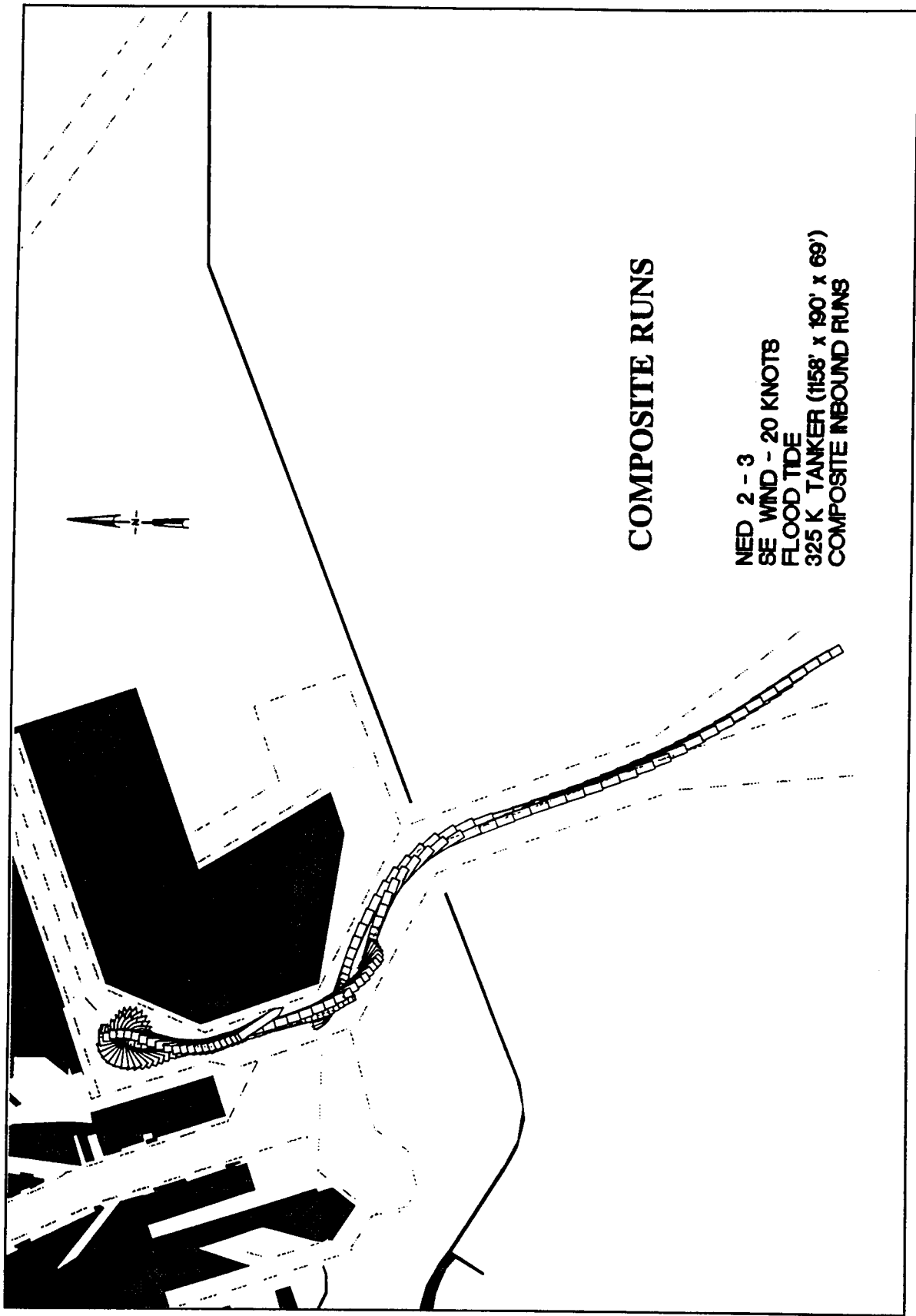

**COMPOSITE RUNS**

**NED 2 - 3  
SE WIND - 20 KNOTS  
FLOOD TIDE  
325 K TANKER (158' x 190' x 69')  
COMPOSITE INBOUND RUNS**

Plate 94

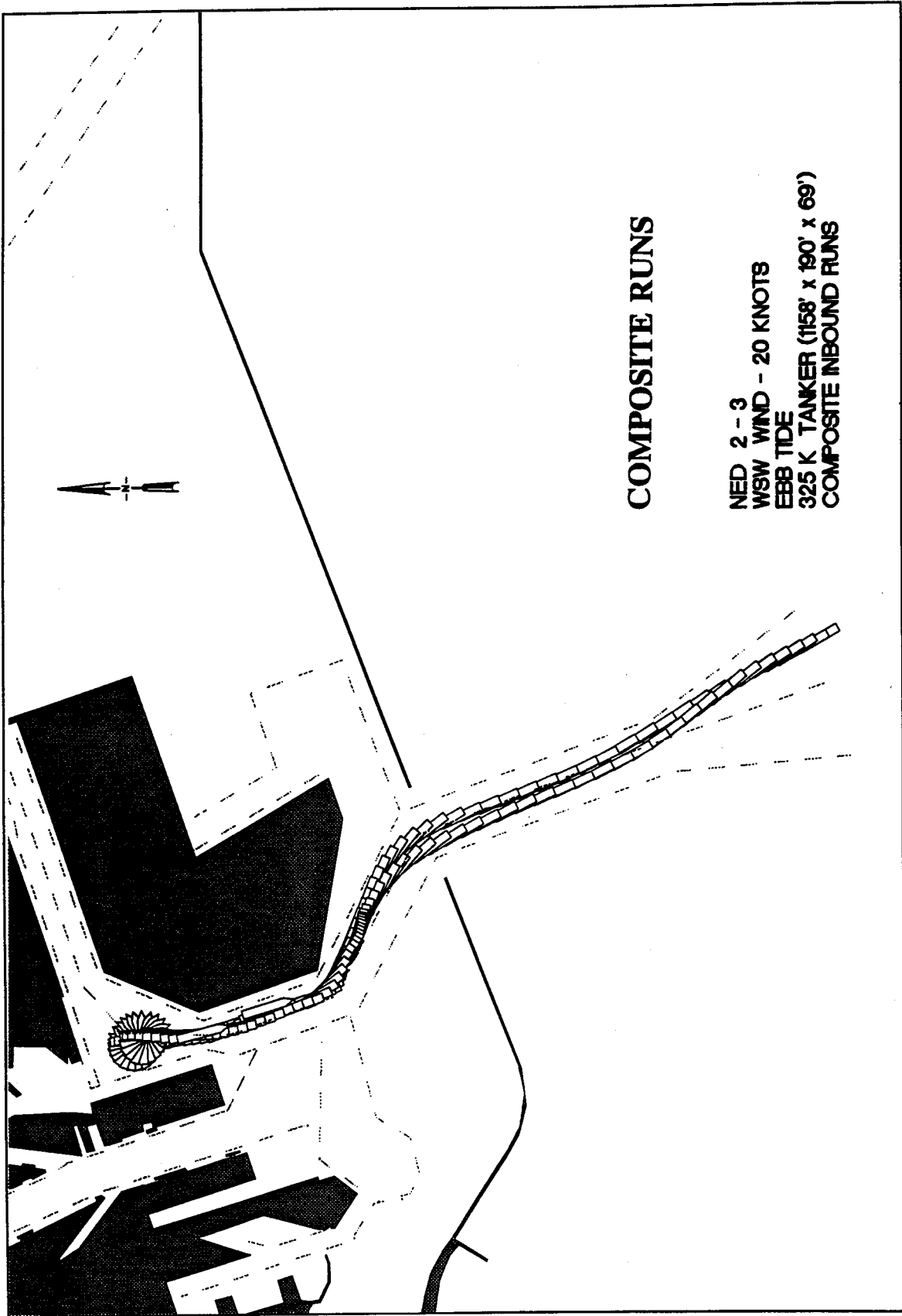

**COMPOSITE RUNS**

**NED 2-3  
WSW WIND - 20 KNOTS  
EBB TIDE  
325 K TANKER (158' x 190' x 69')  
COMPOSITE INBOUND RUNS**

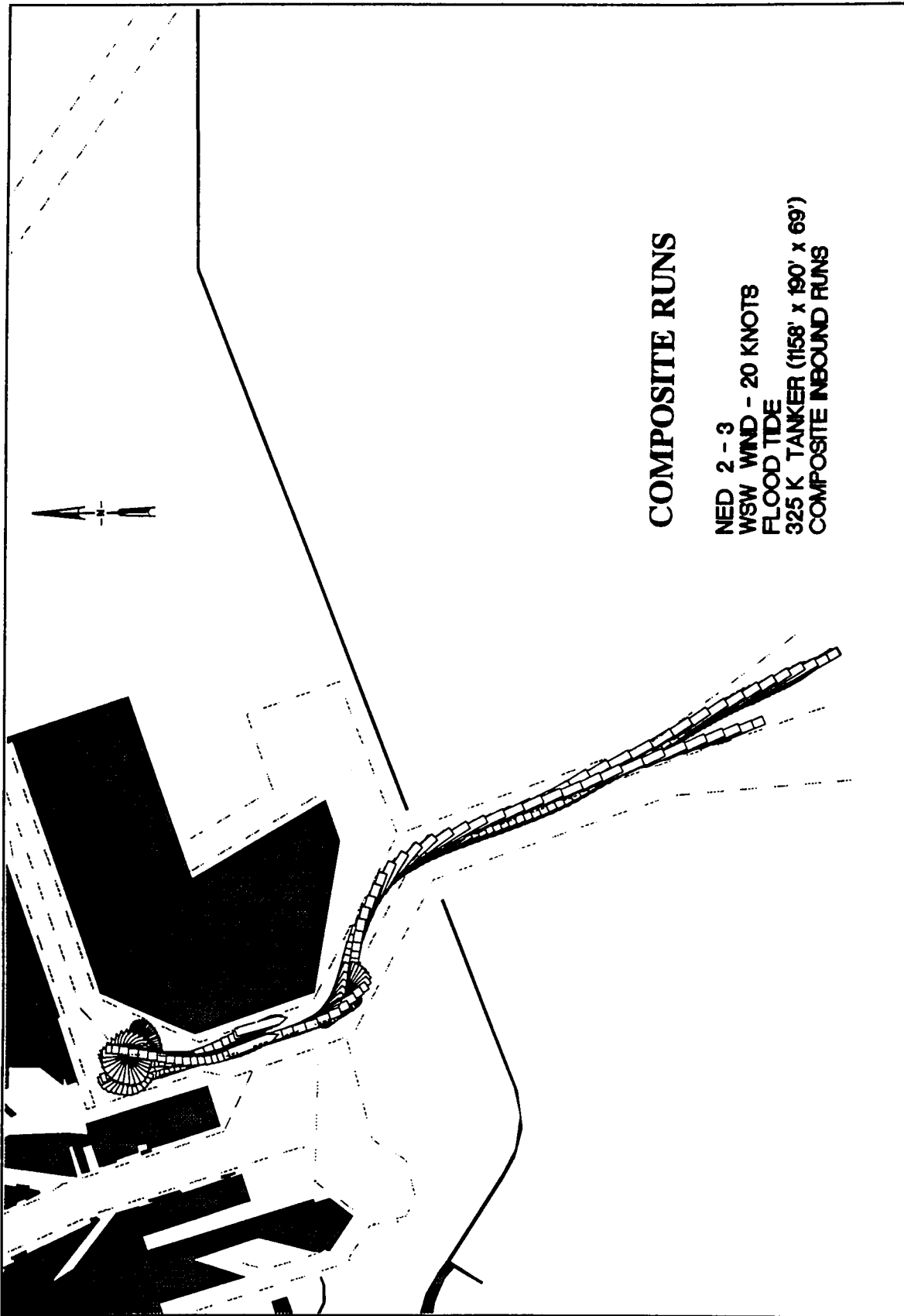
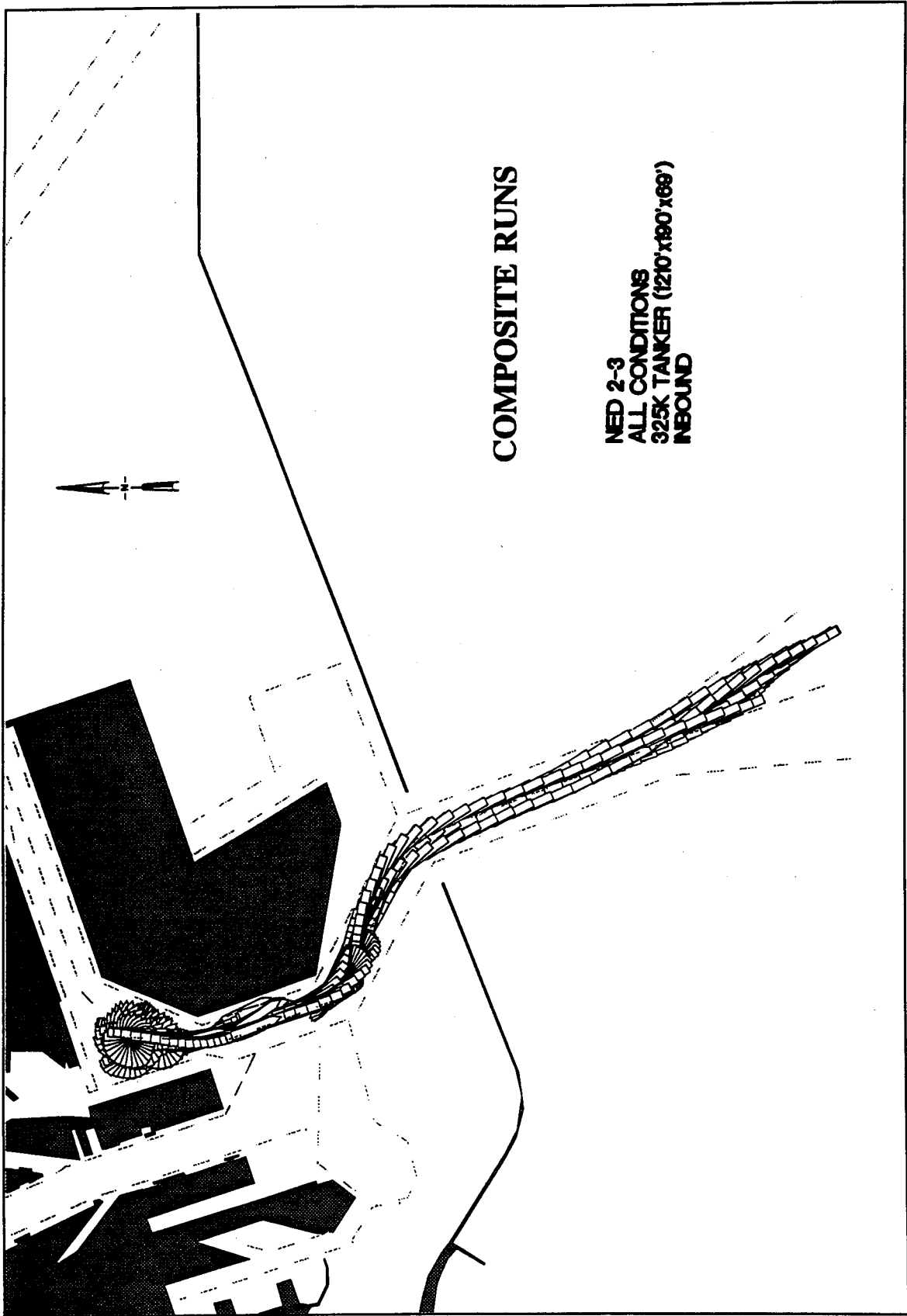
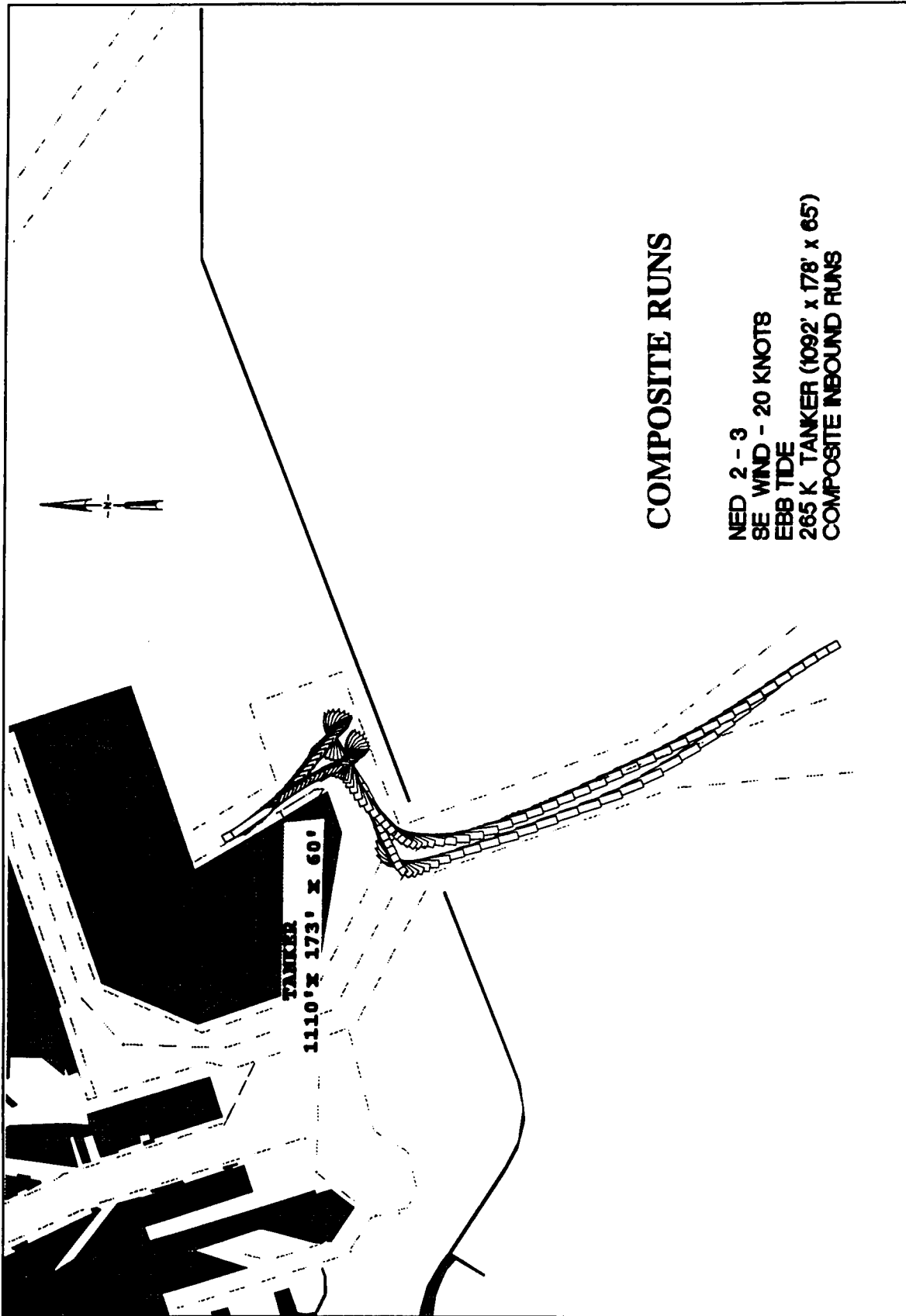

Plate 96



**COMPOSITE RUNS**

**NED 2-3  
ALL CONDITIONS  
325K TANKER (1210'x190'x69')  
INBOUND**



**COMPOSITE RUNS**

NED 2 - 3  
 SE WIND - 20 KNOTS  
 EBB TIDE  
 265 K TANKER (1092' x 178' x 65')  
 COMPOSITE INBOUND RUNS

TANKER  
 1110' x 173' x 60'

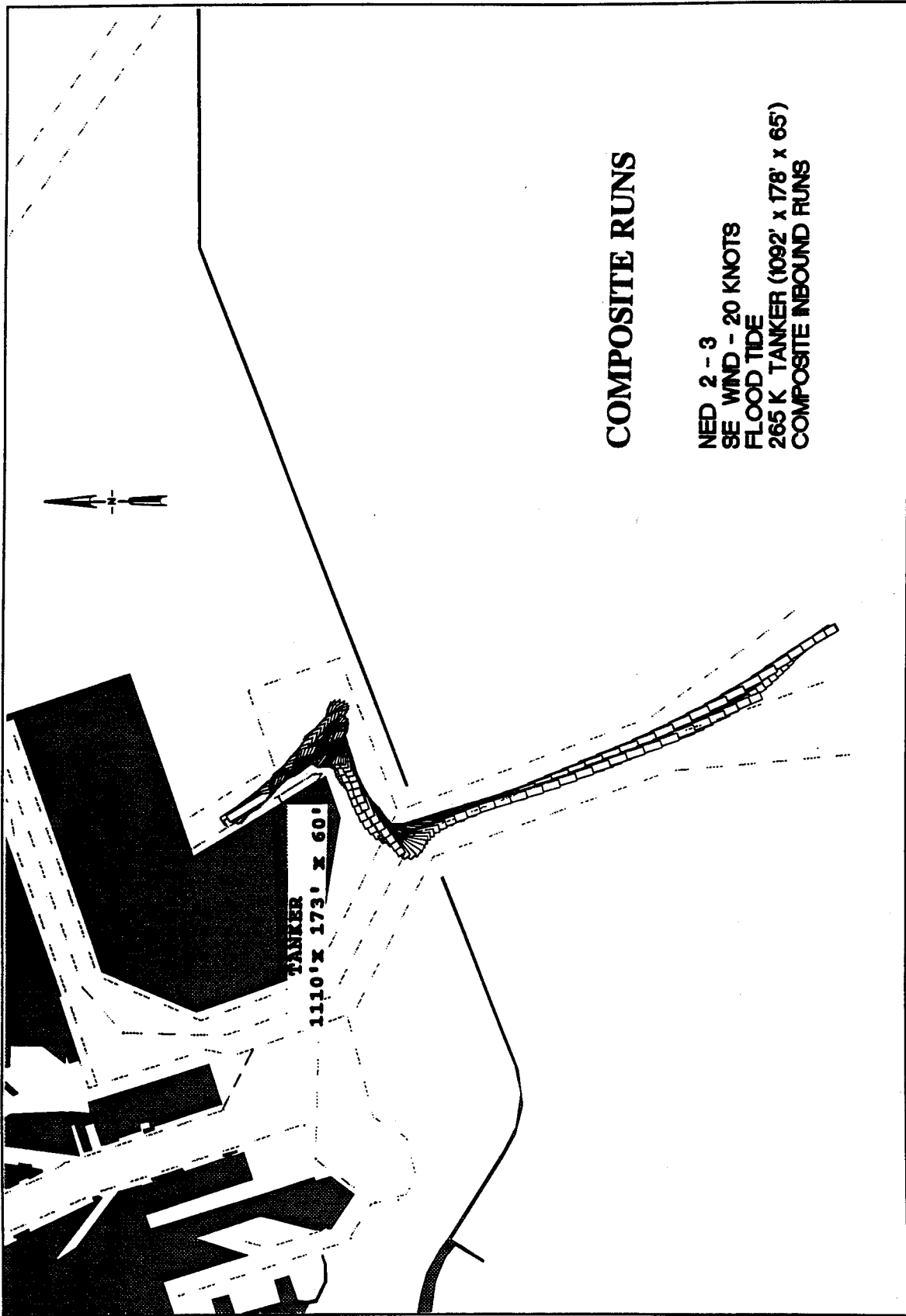

**COMPOSITE RUNS**

NEED 2-3  
SE WIND - 20 KNOTS  
FLOOD TIDE  
265 K TANKER (1092' x 178' x 65')  
COMPOSITE INBOUND RUNS

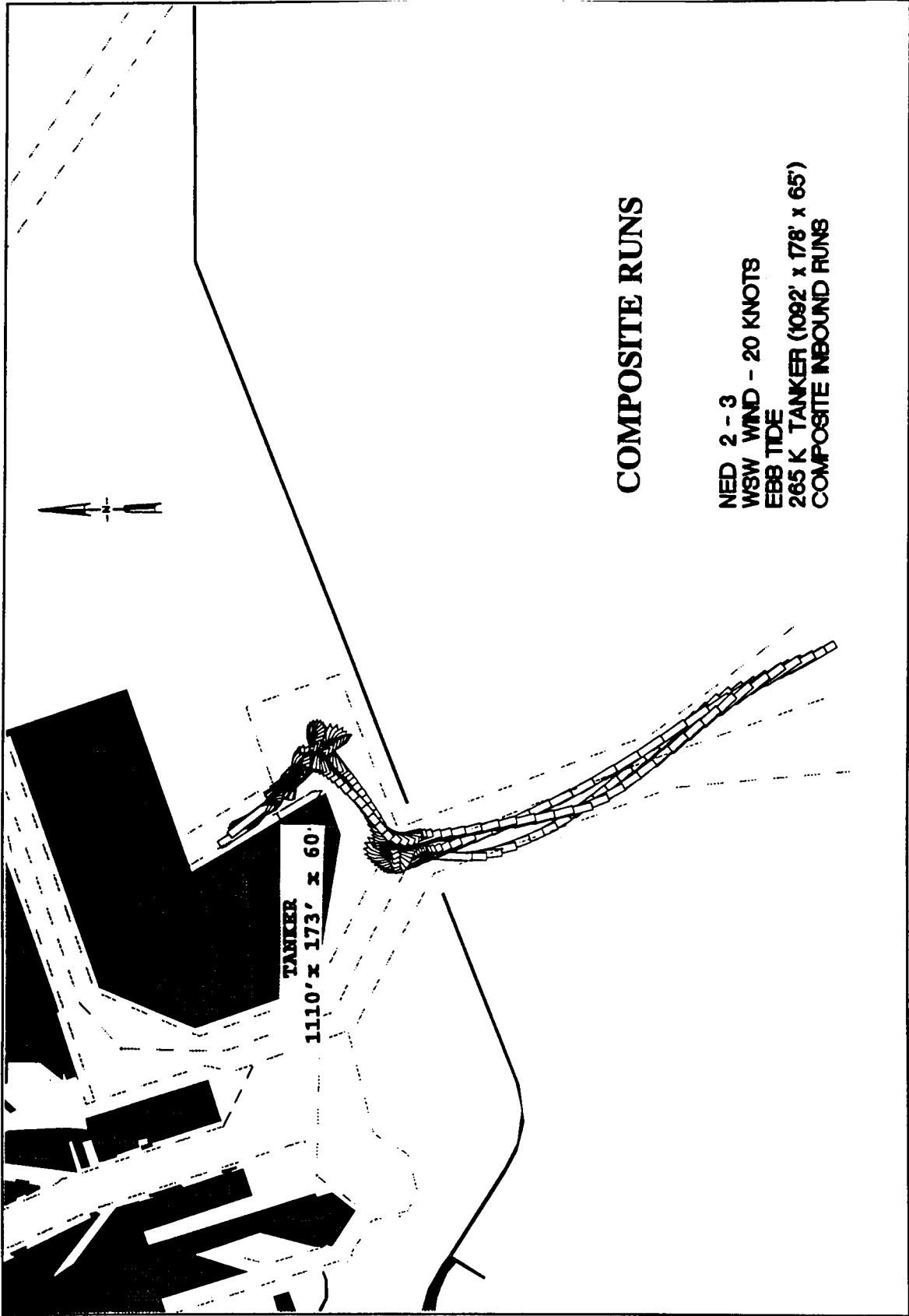

**COMPOSITE RUNS**

NED 2 - 3  
 WSW WIND - 20 KNOTS  
 EBB TIDE  
 265 K TANKER (1092' x 178' x 65')  
 COMPOSITE INBOUND RUNS

Plate 100

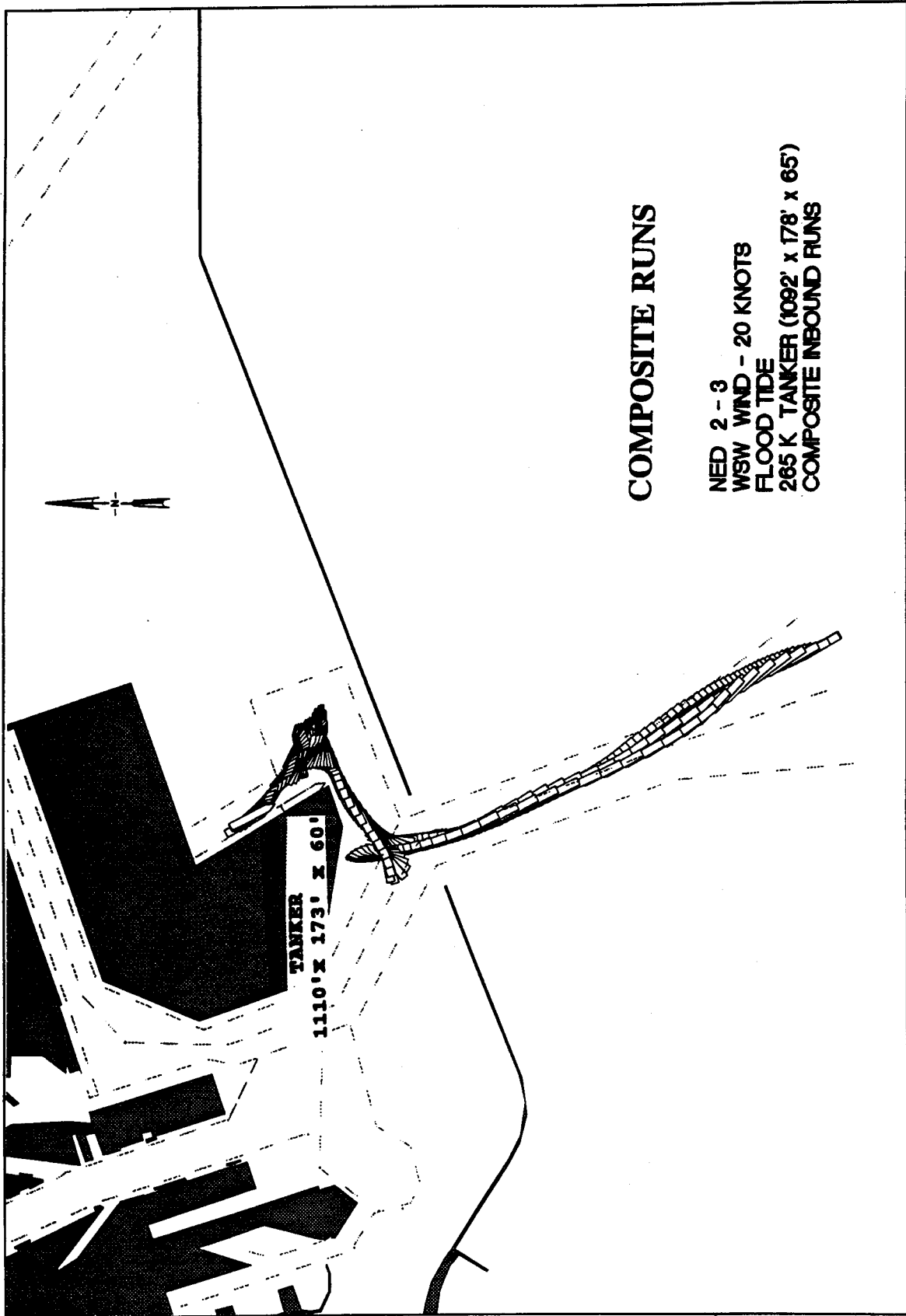

**COMPOSITE RUNS**

NED 2-3  
WSW WIND - 20 KNOTS  
FLOOD TIDE  
265 K TANKER (1092' x 178' x 65')  
COMPOSITE INBOUND RUNS

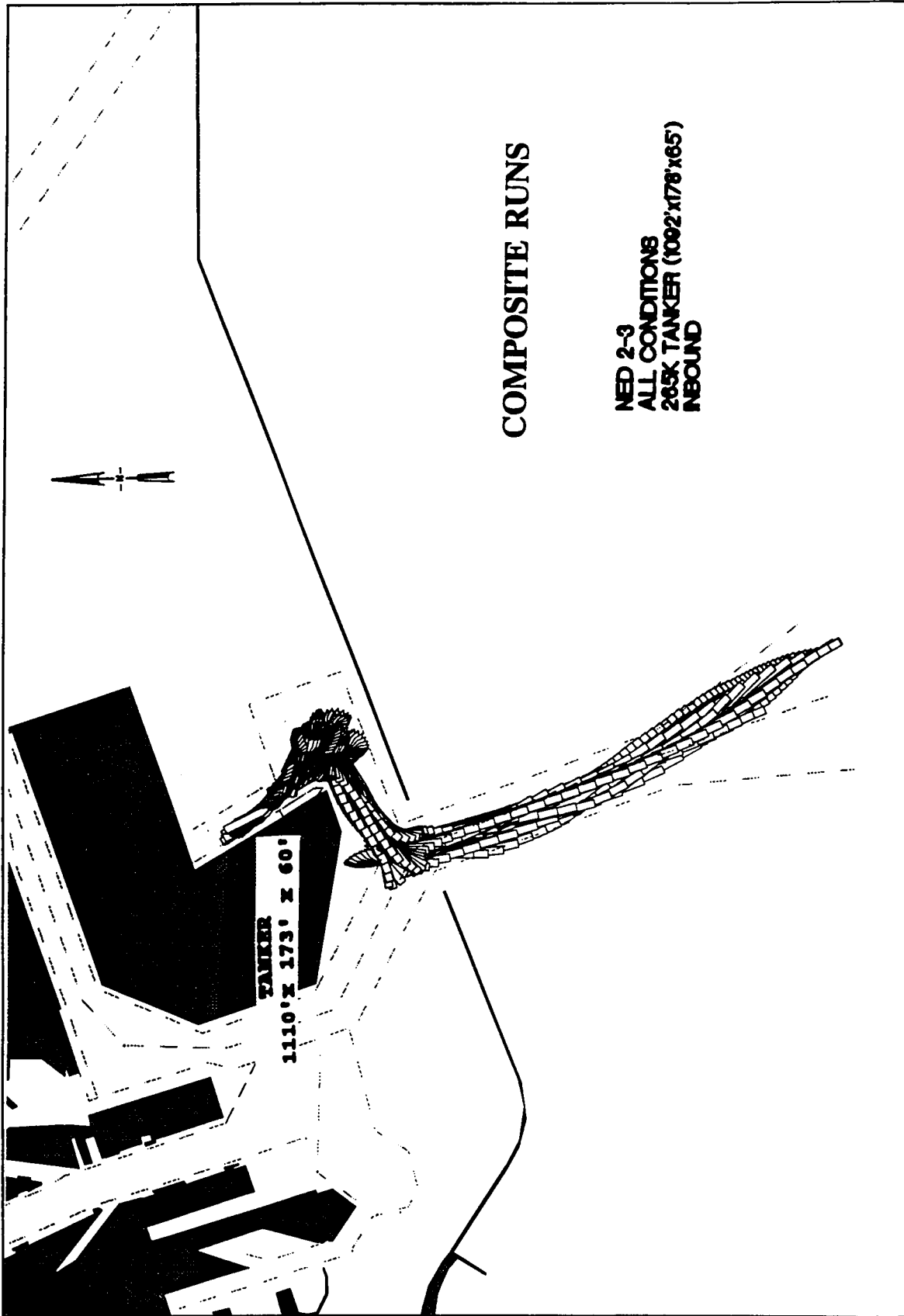

**COMPOSITE RUNS**

**NED 2-3  
ALL CONDITIONS  
265K TANKER (1092'x178'x65')  
INBOUND**

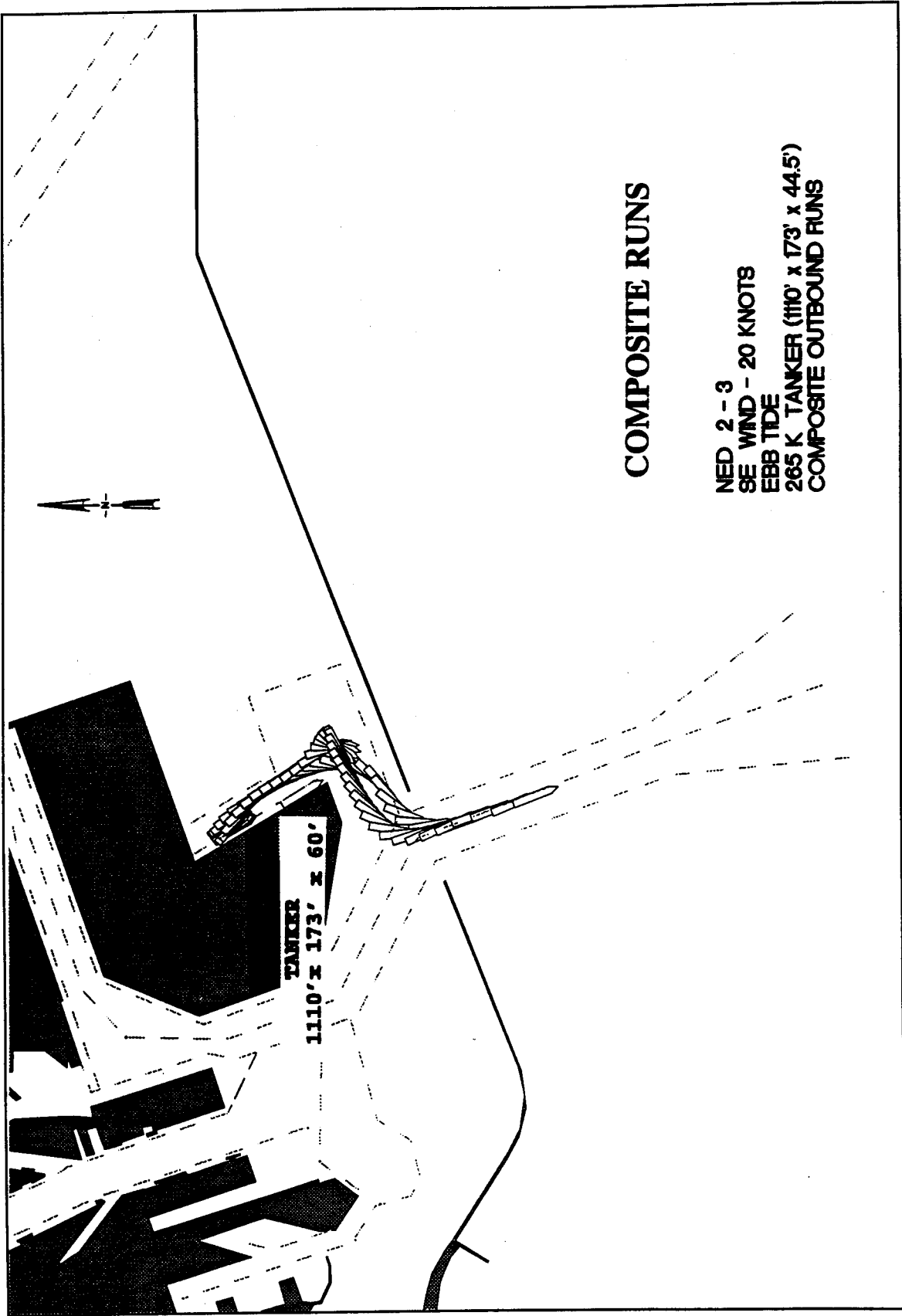

**COMPOSITE RUNS**

**NED 2 - 3  
SE WIND - 20 KNOTS  
EBB TIDE  
265 K TANKER (1110' x 173' x 44.5')  
COMPOSITE OUTBOUND RUNS**

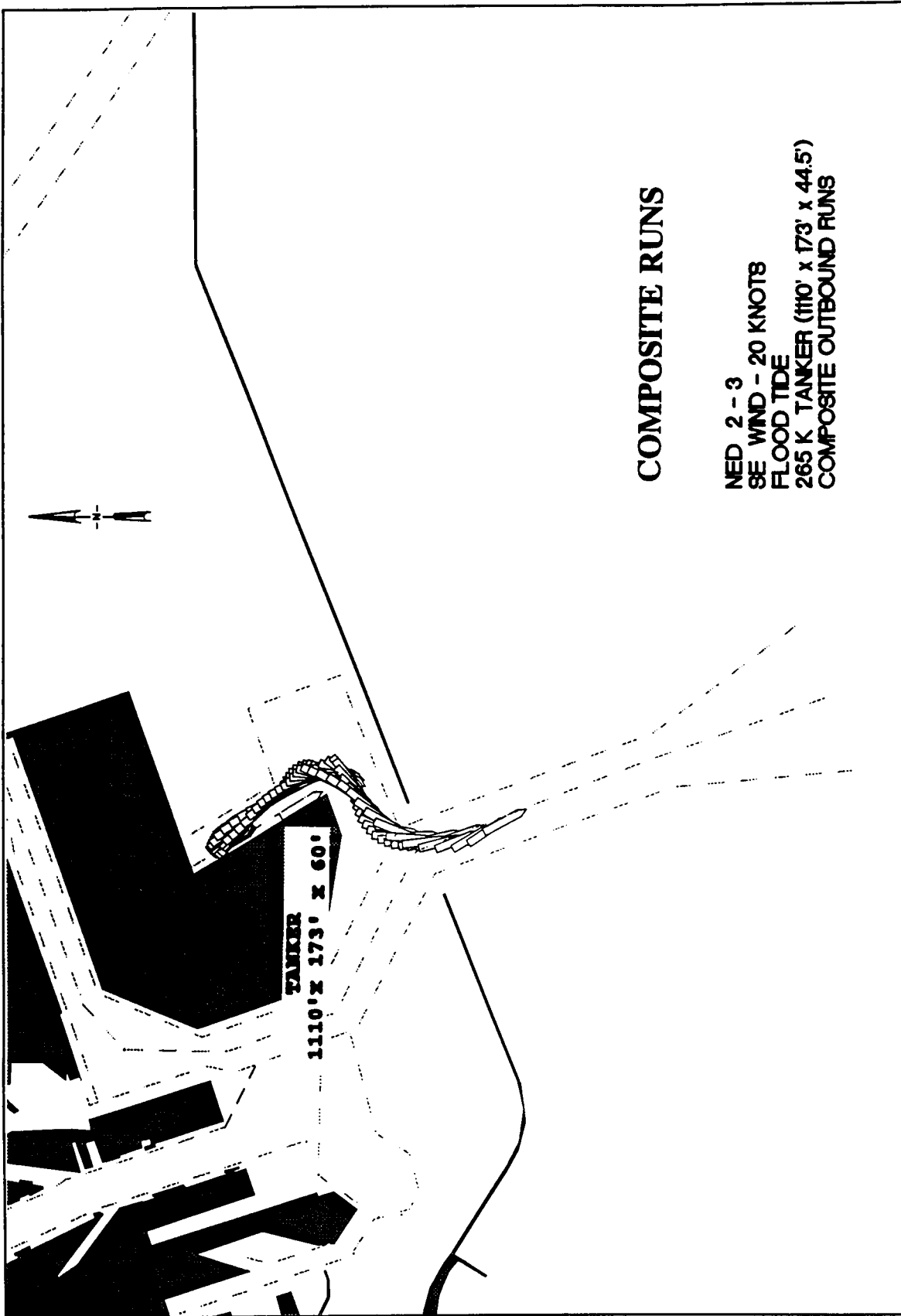
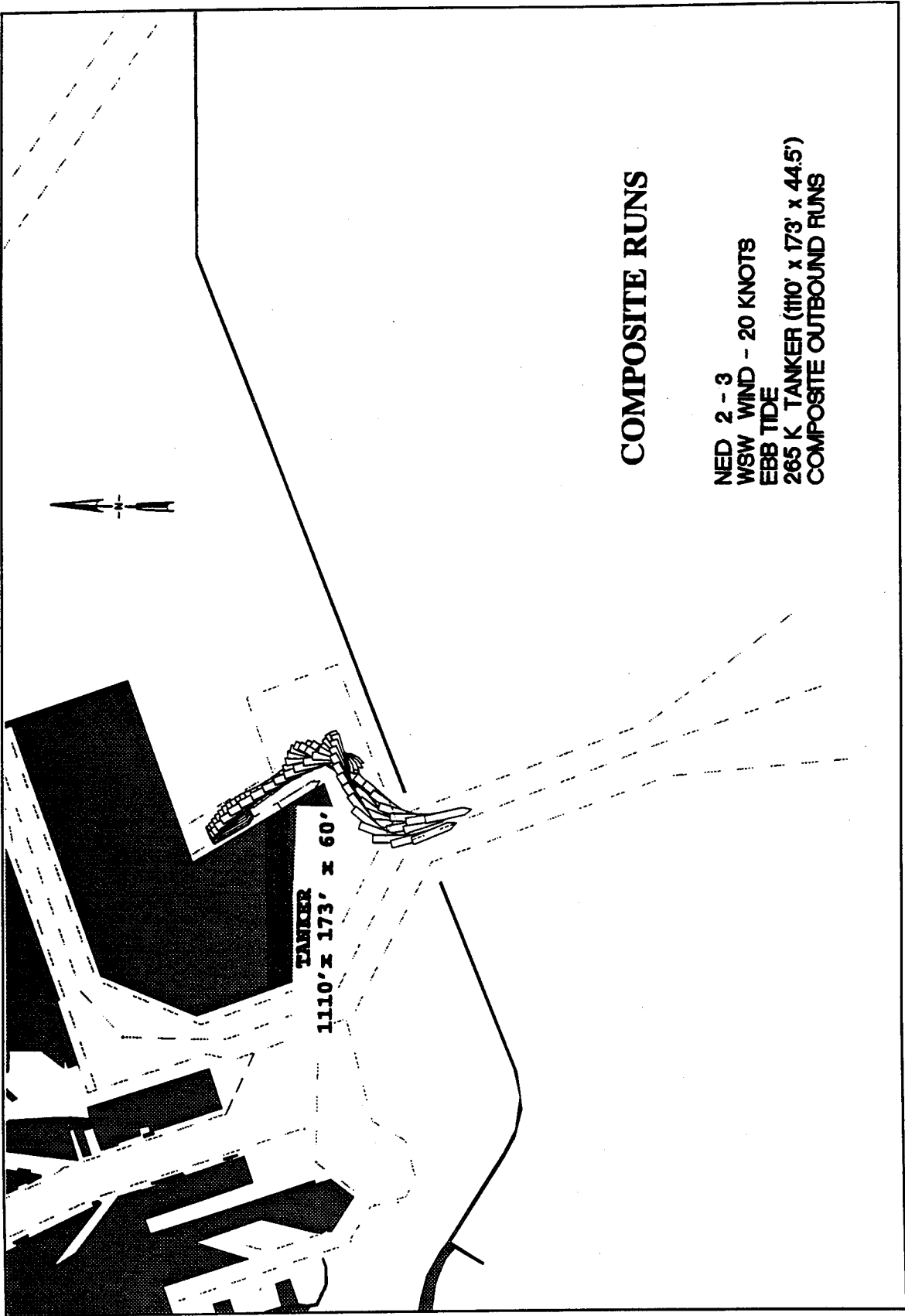

Plate 104



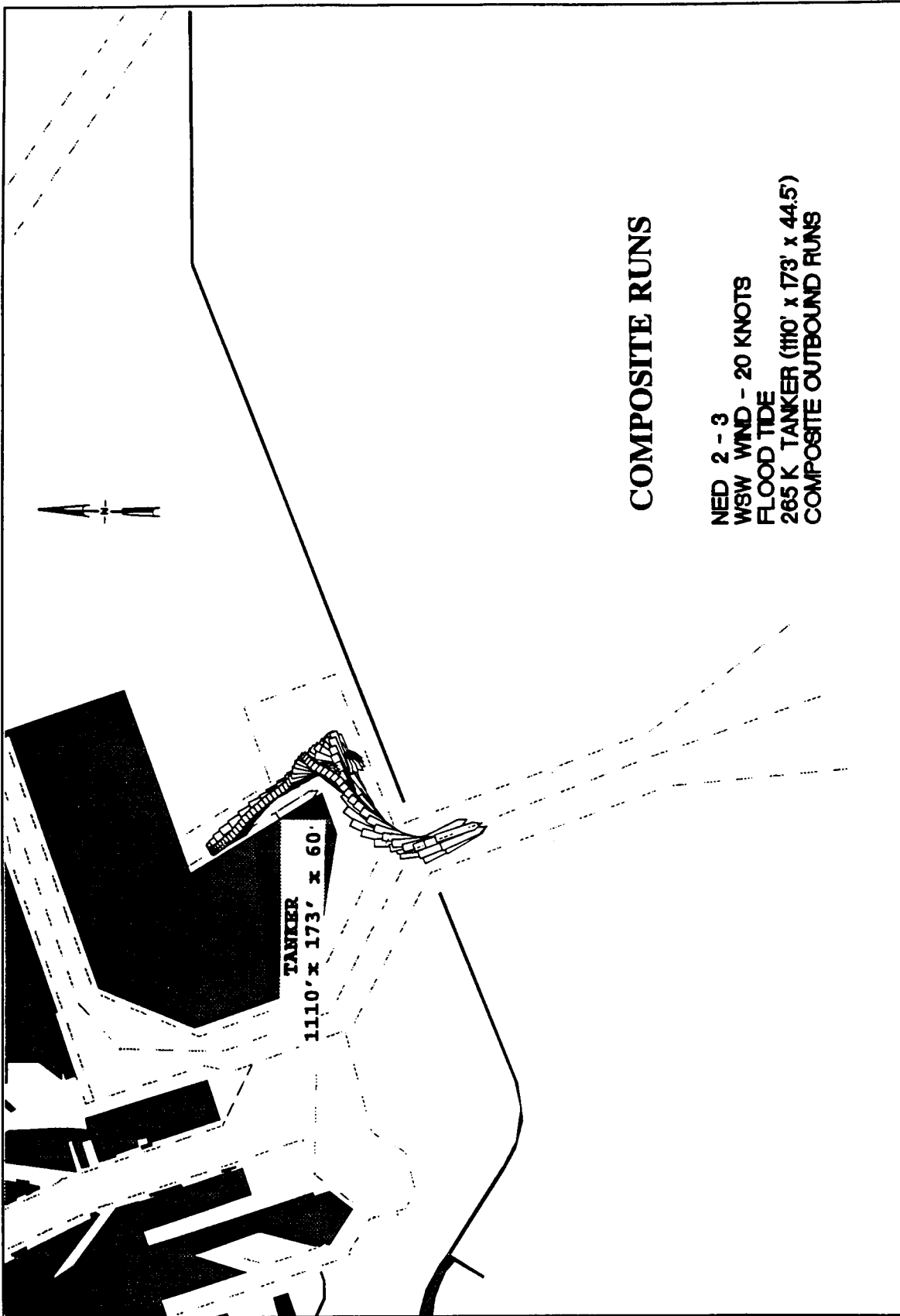
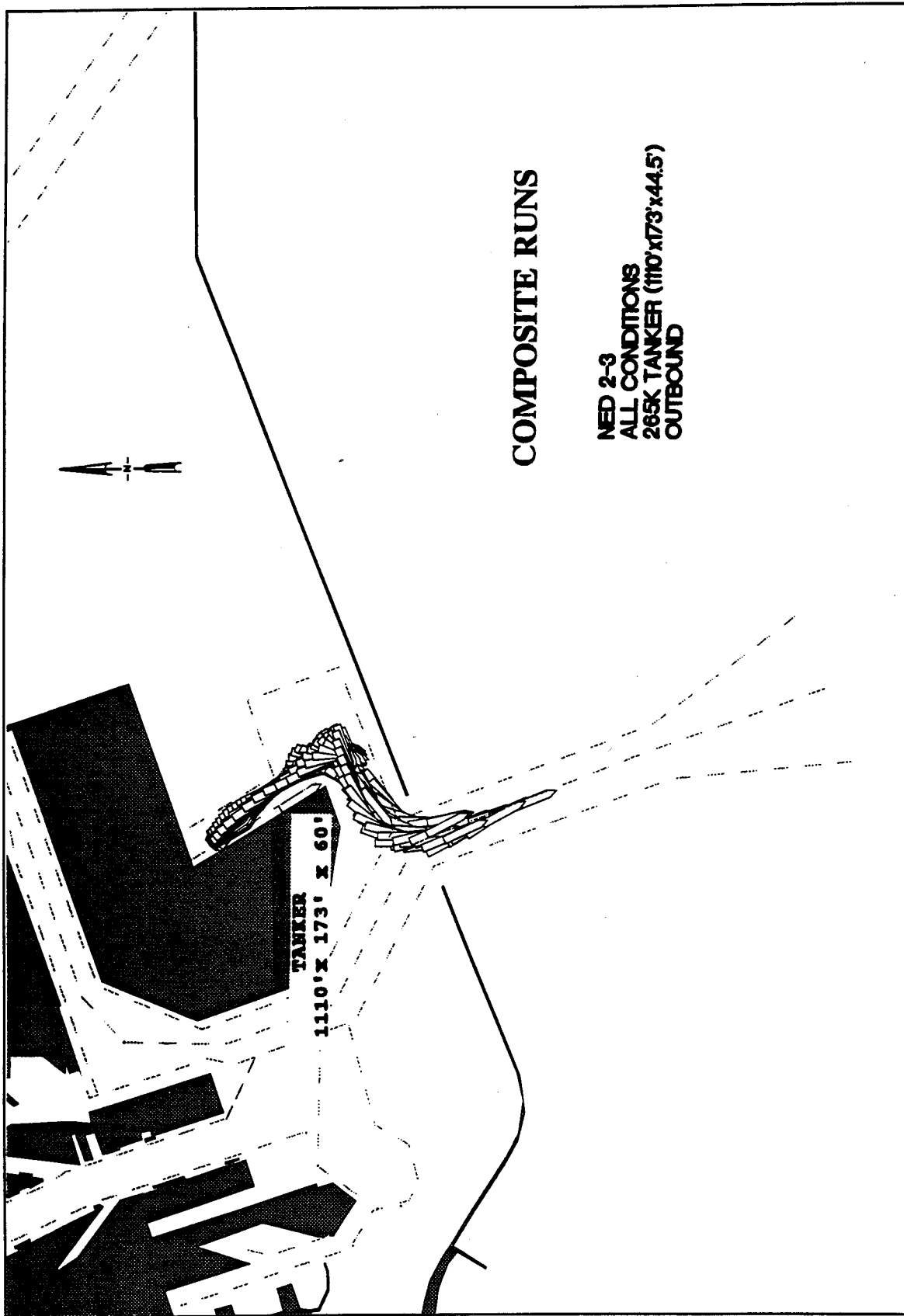

Plate 106



**COMPOSITE RUNS**

**NED 2-3  
ALL CONDITIONS  
265K TANKER (1110'X173'X44.5')  
OUTBOUND**

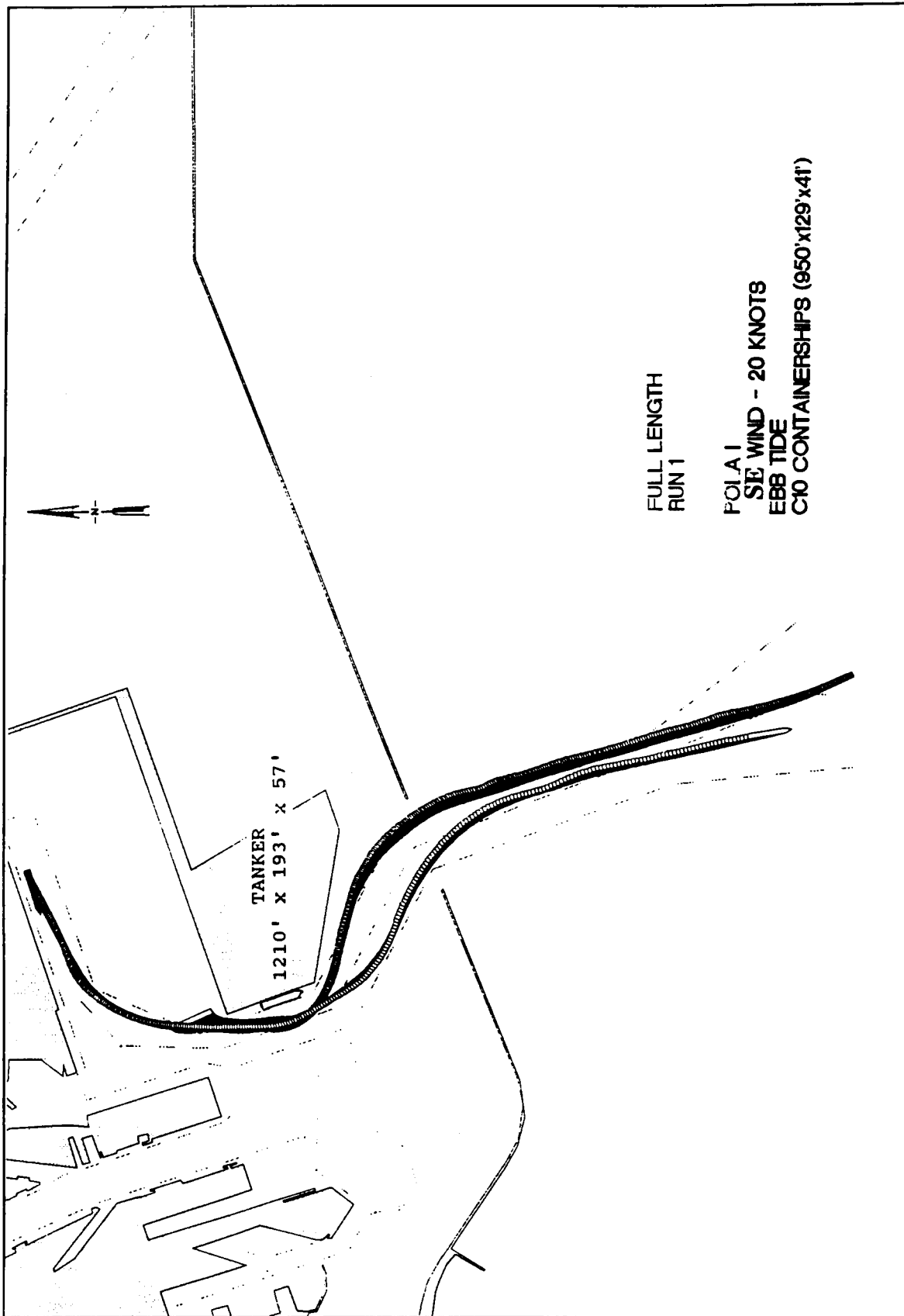
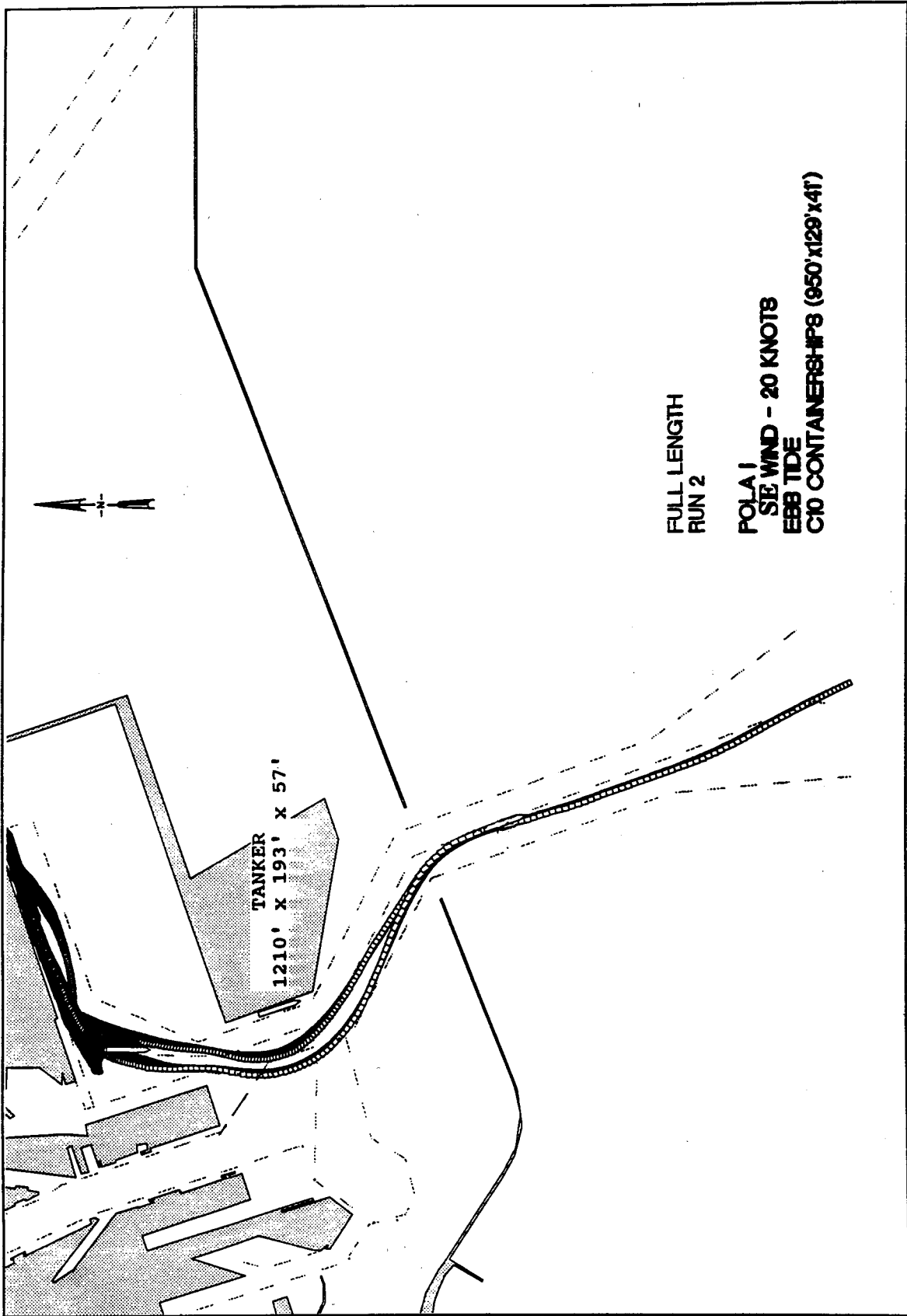

Plate 108



TANKER  
1210' x 193' x 57'

FULL LENGTH  
RUN 2

POLA 1  
SE WIND - 20 KNOTS  
EBB TIDE  
C10 CONTAINERSHIPS (950'x129'x41)

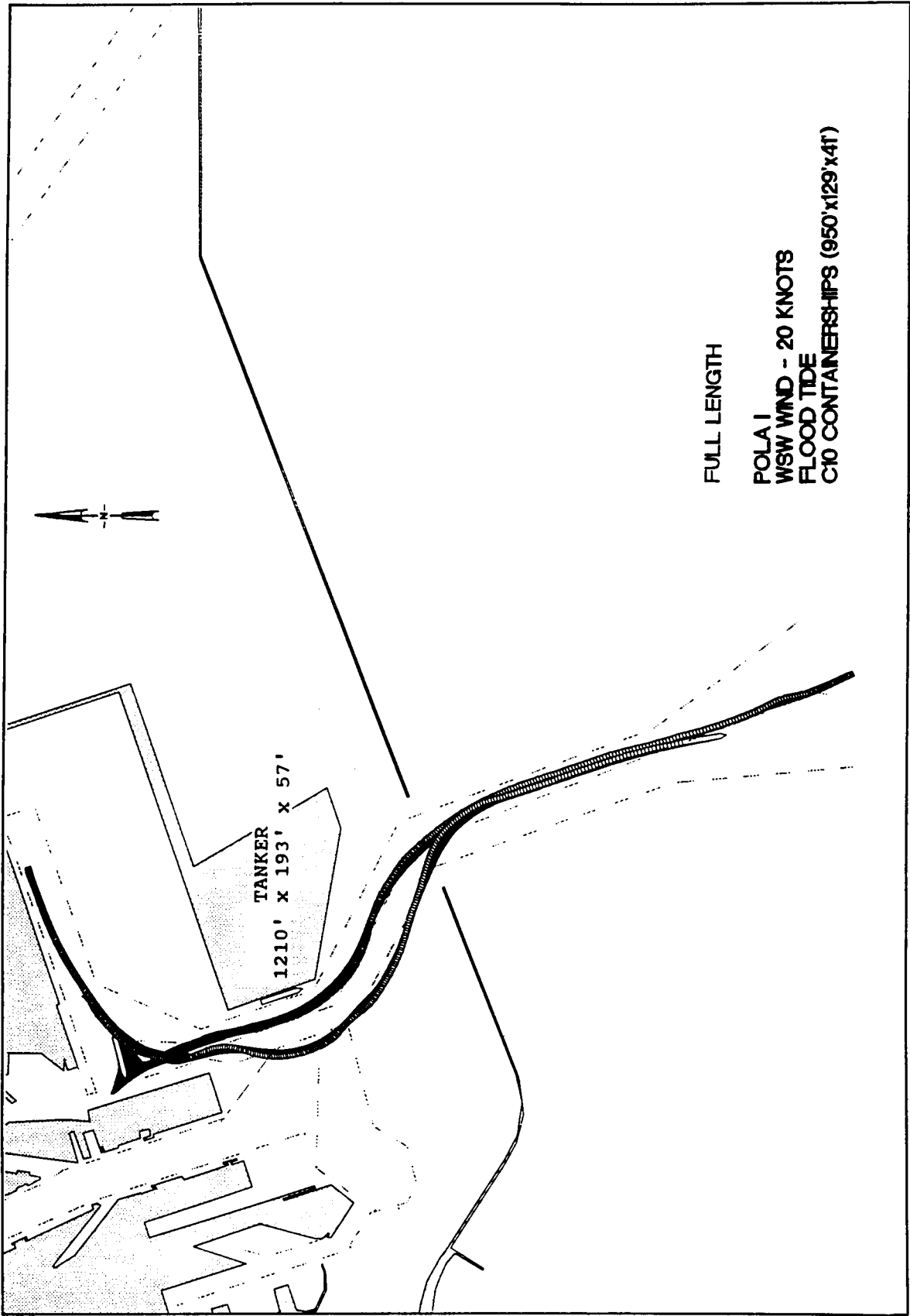
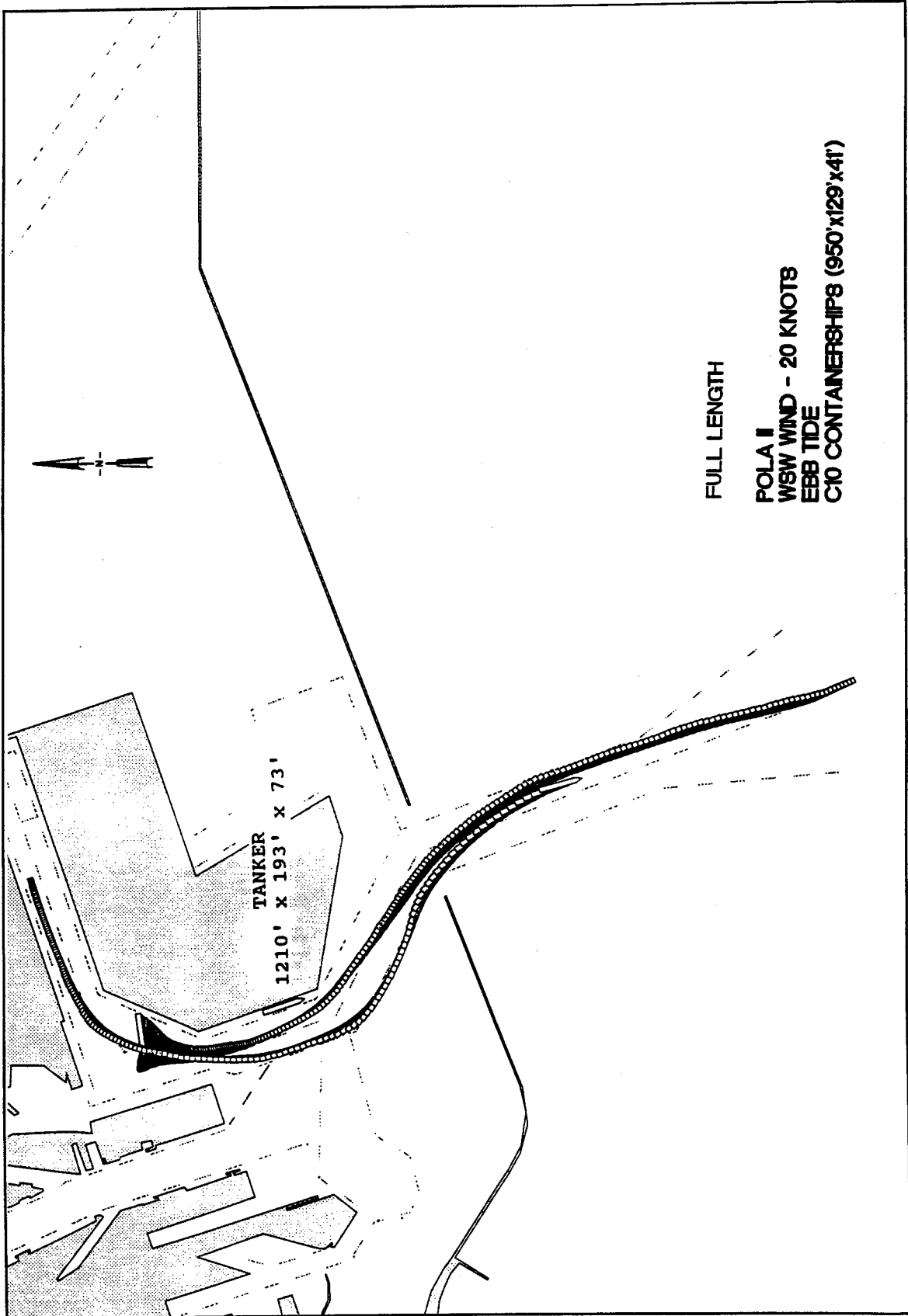

Plate 110



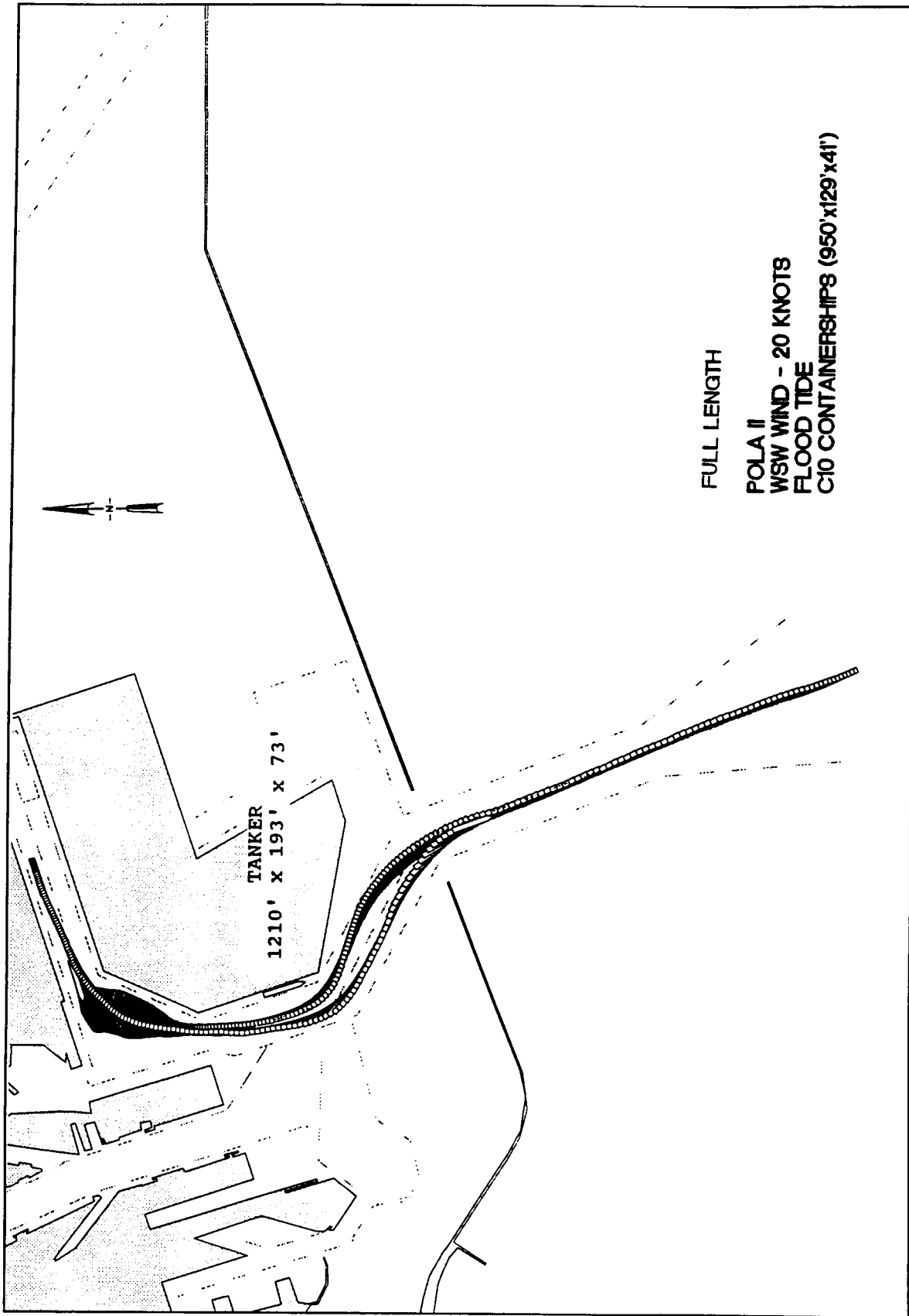

Plate 112

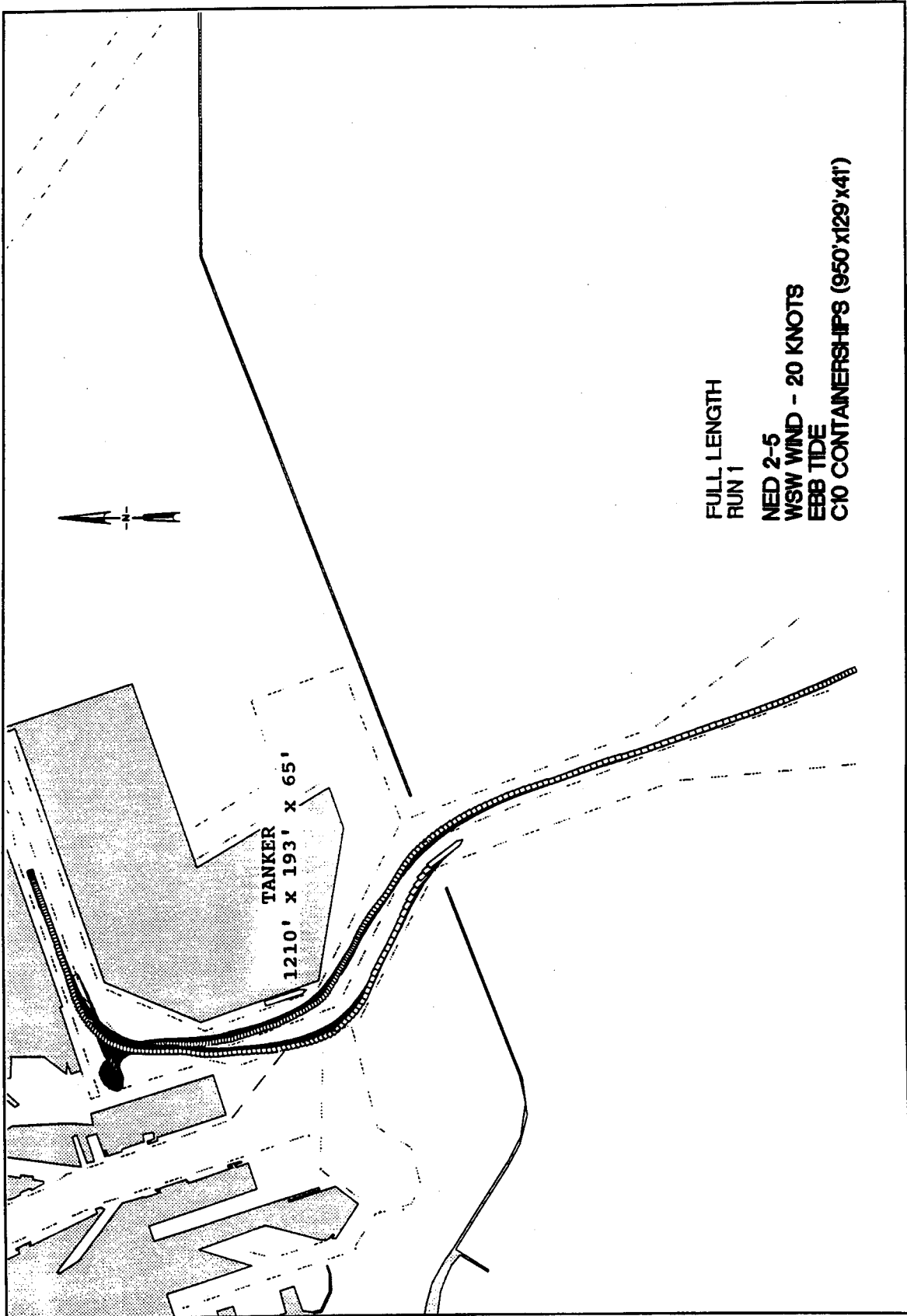

Plate 113

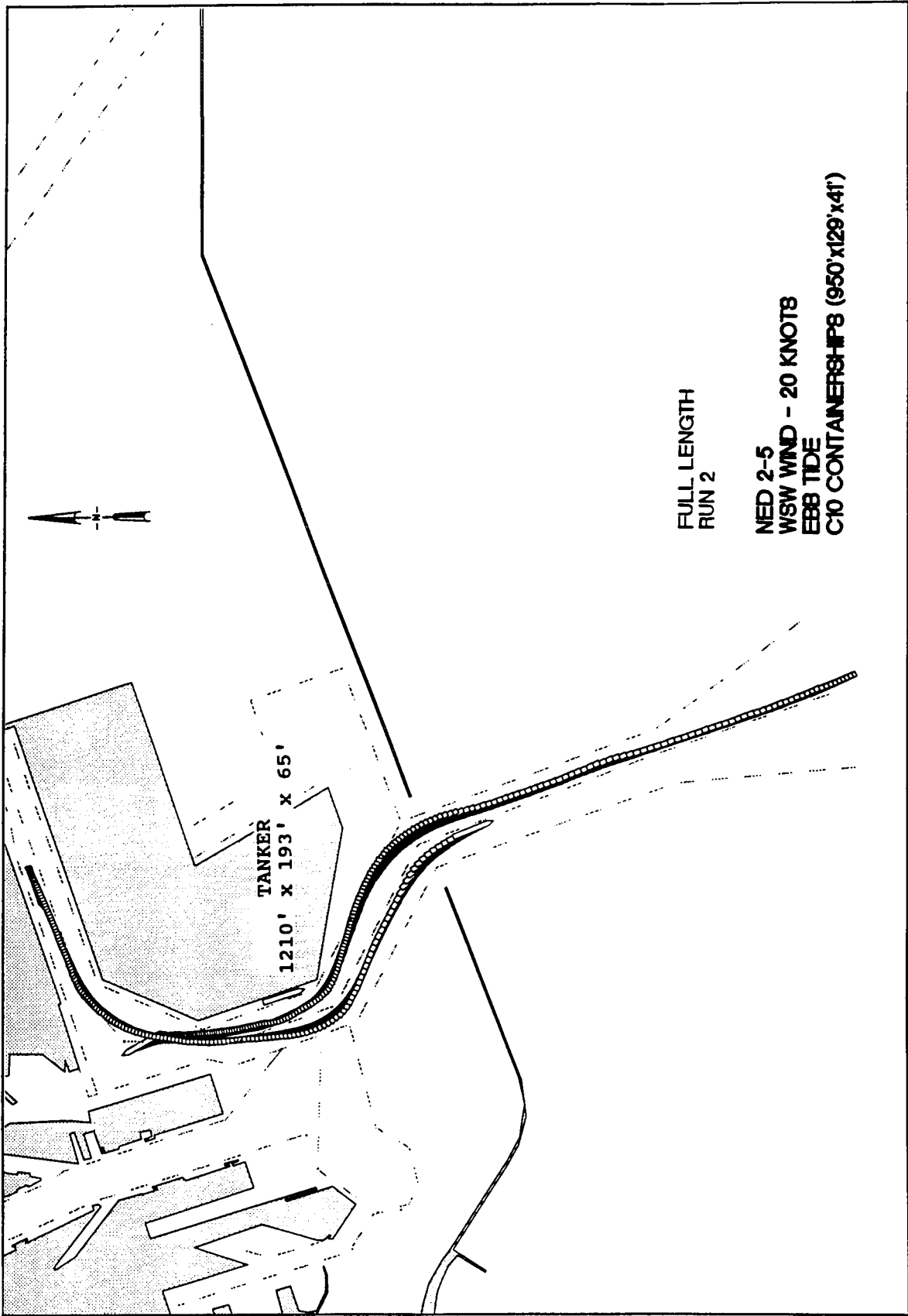
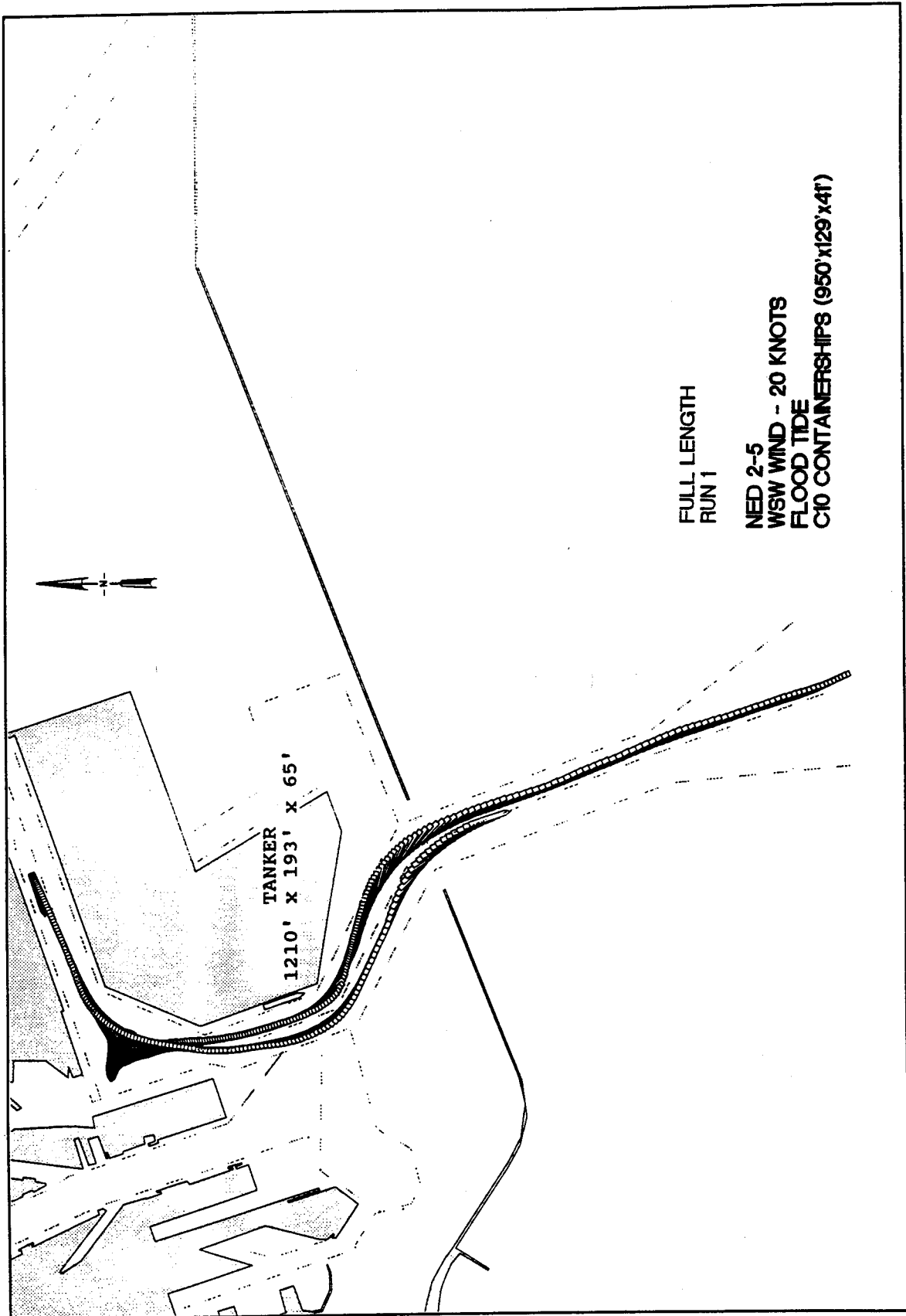

Plate 114



FULL LENGTH  
RUN 1

NED 2-5  
WSW WIND - 20 KNOTS  
FLOOD TIDE  
C10 CONTAINERSHIPS (950'x129'x41')

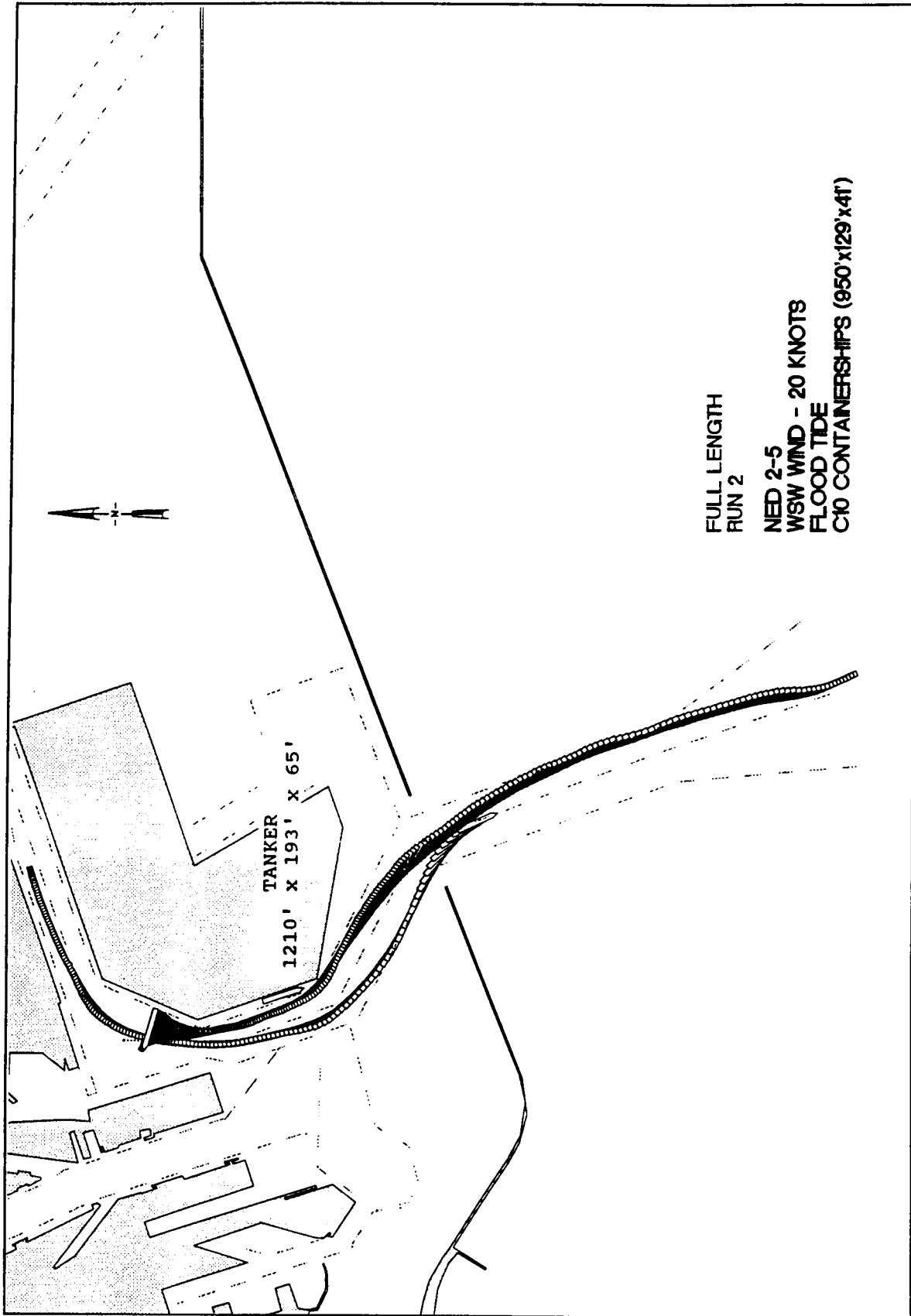
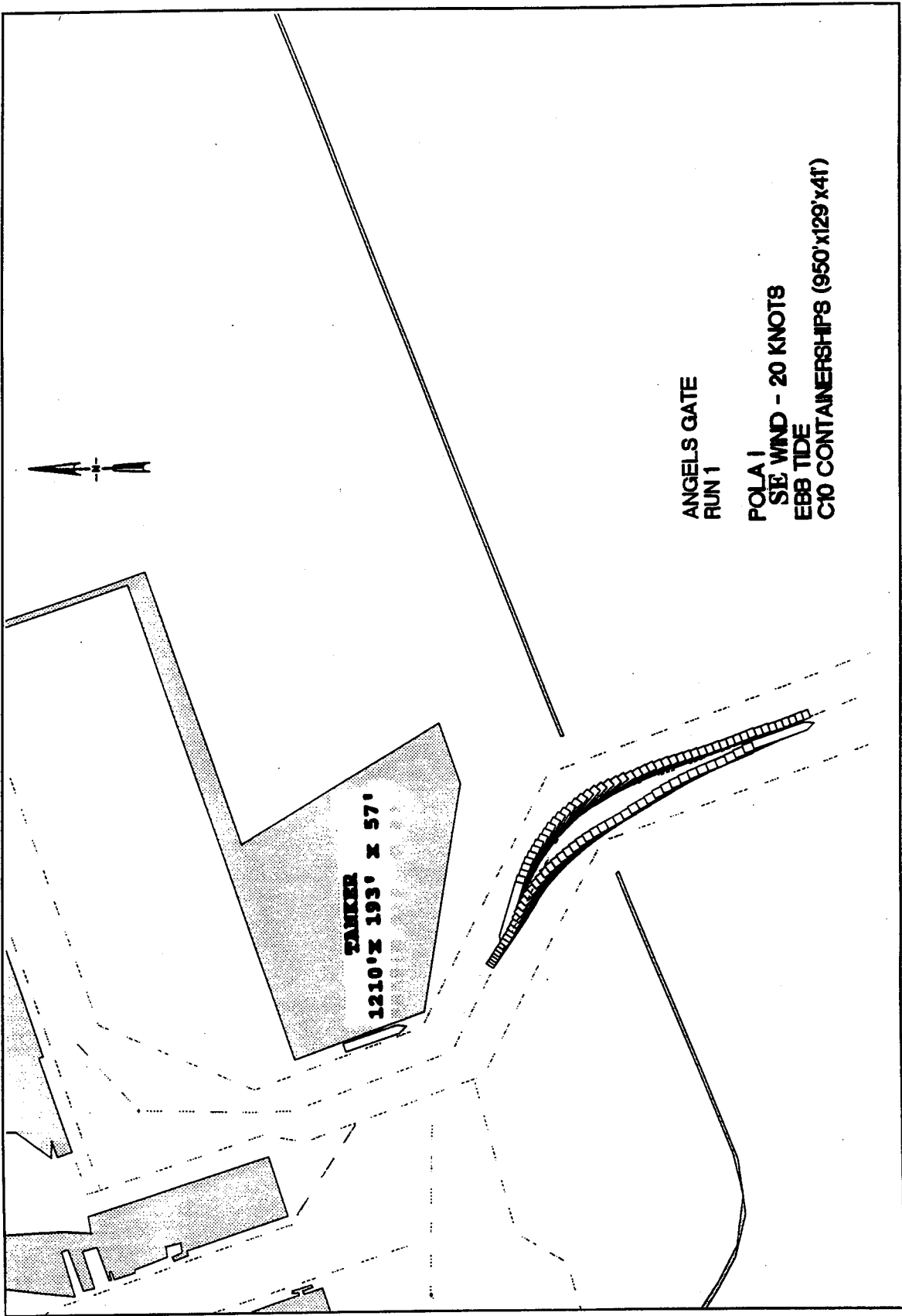

Plate 116



ANGELS GATE  
RUN 1

POLA I  
SE WIND - 20 KNOTS  
EBB TIDE  
C10 CONTAINERSHIPS (950'x129'x41')

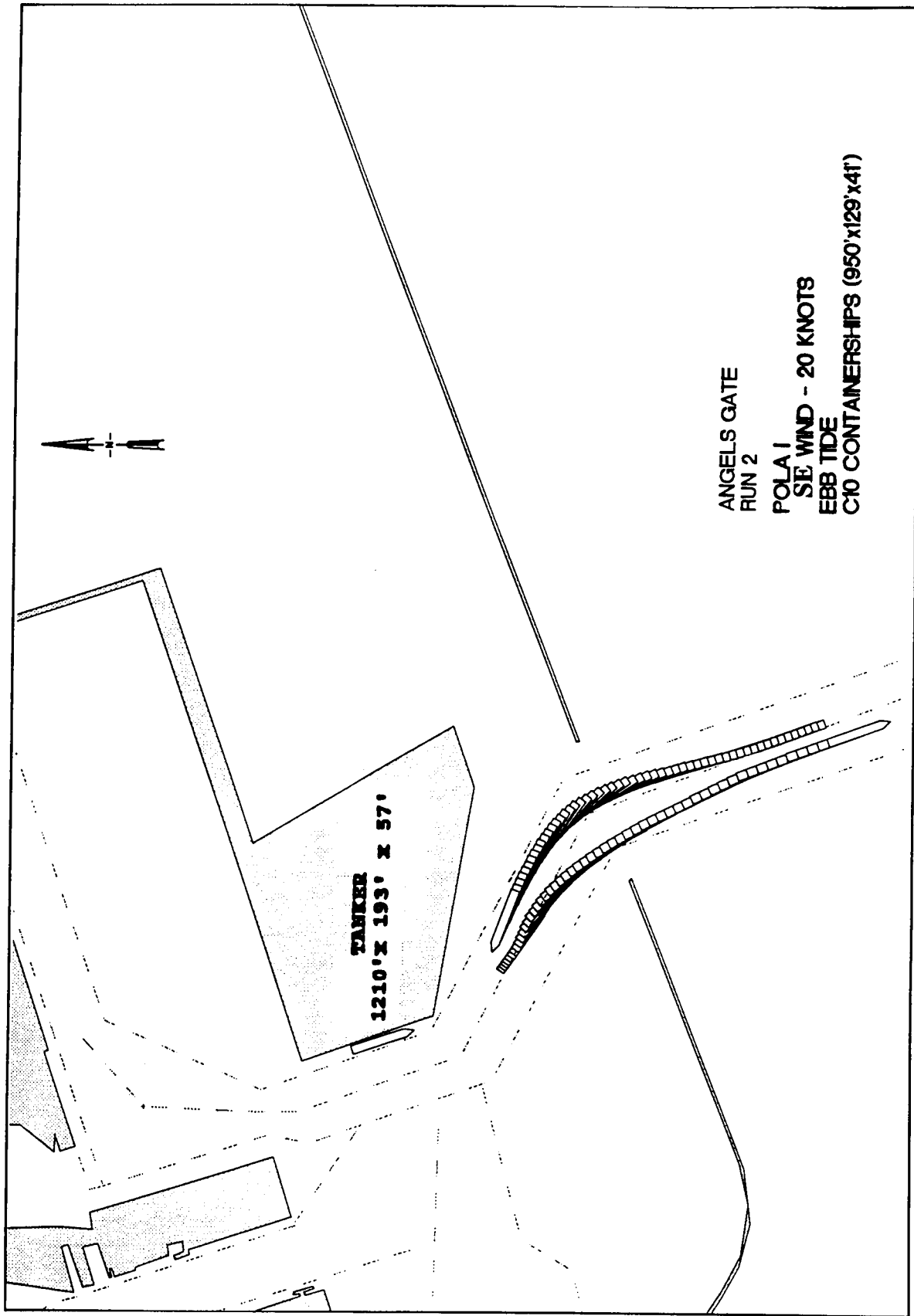
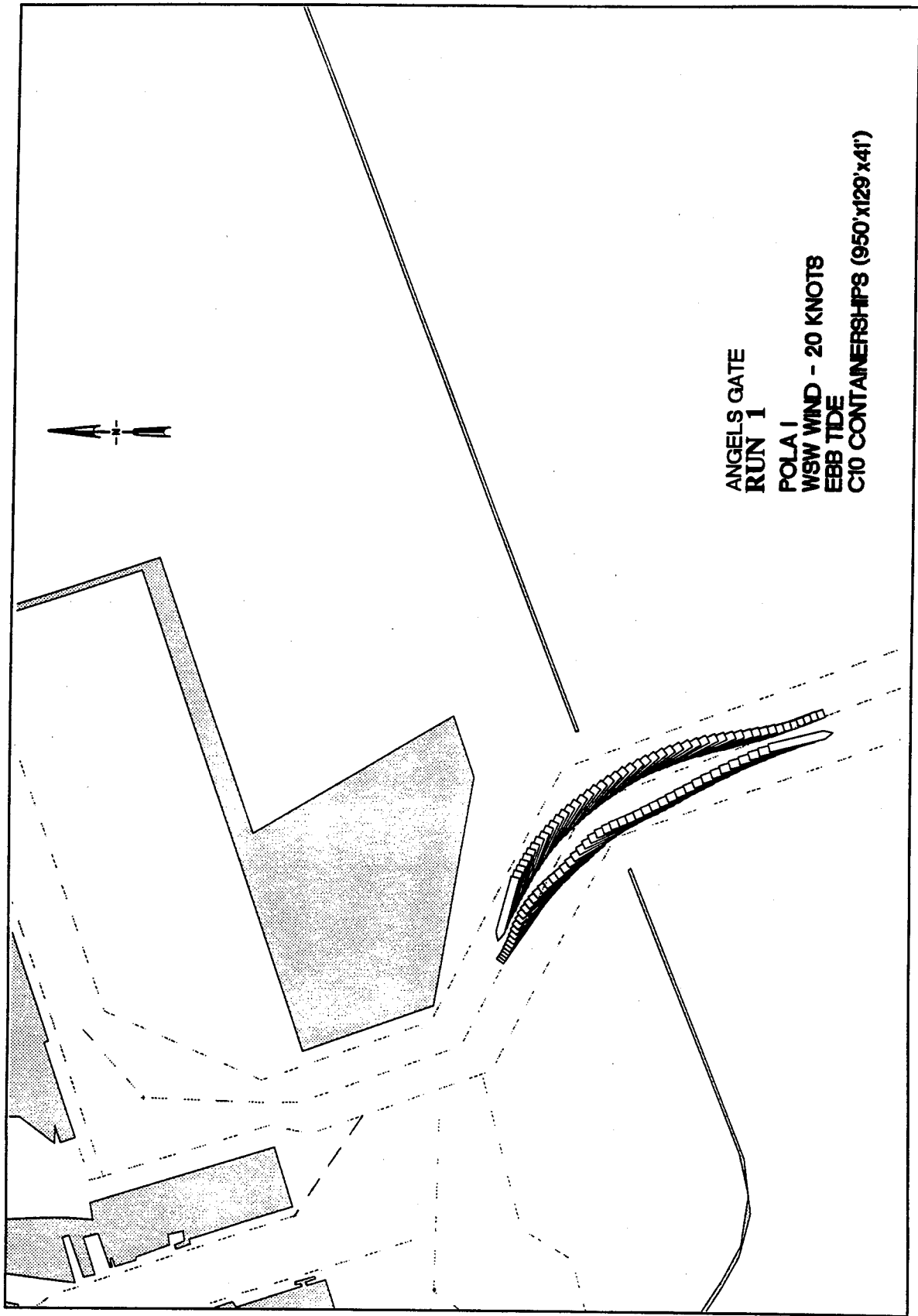

Plate 118



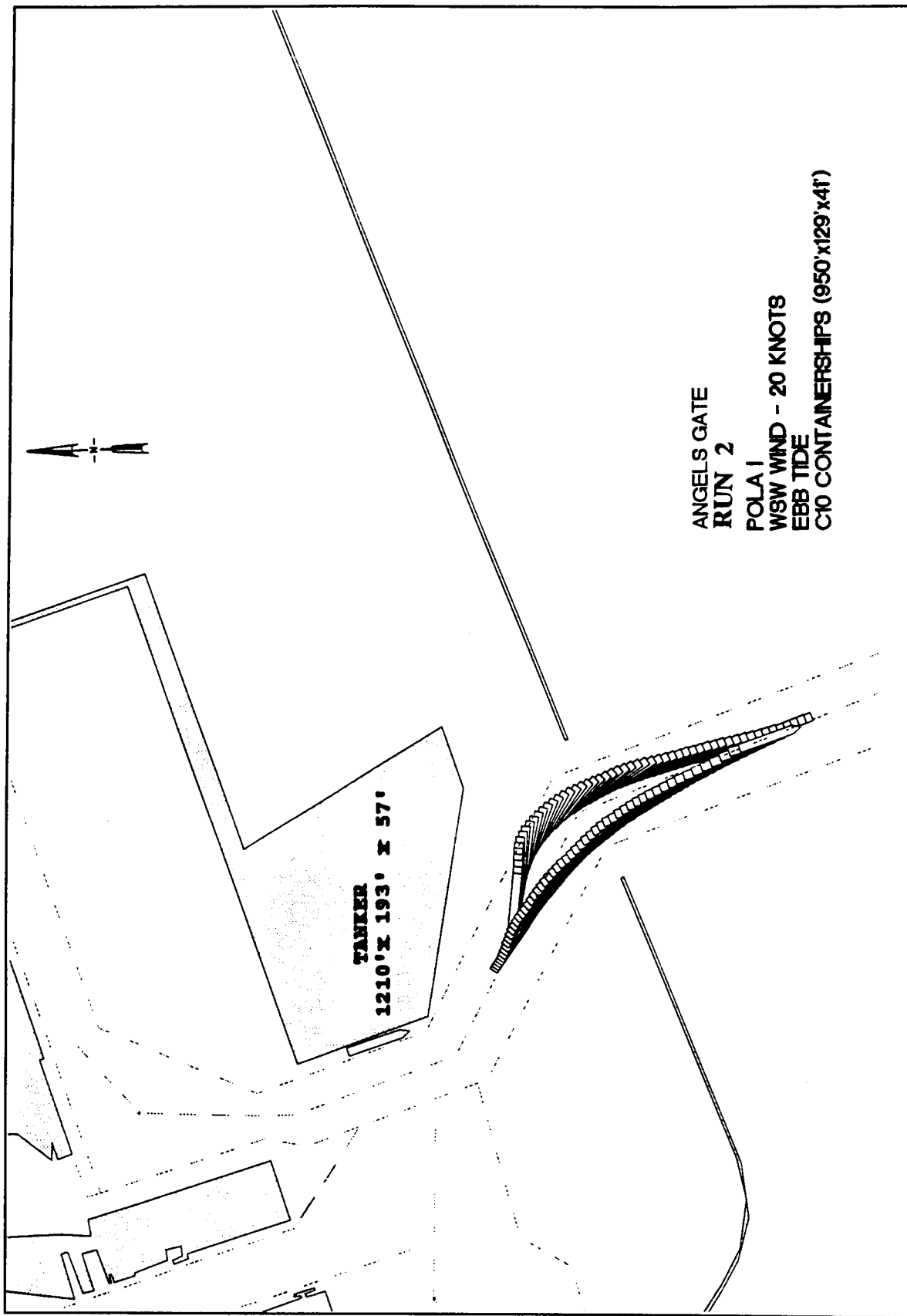
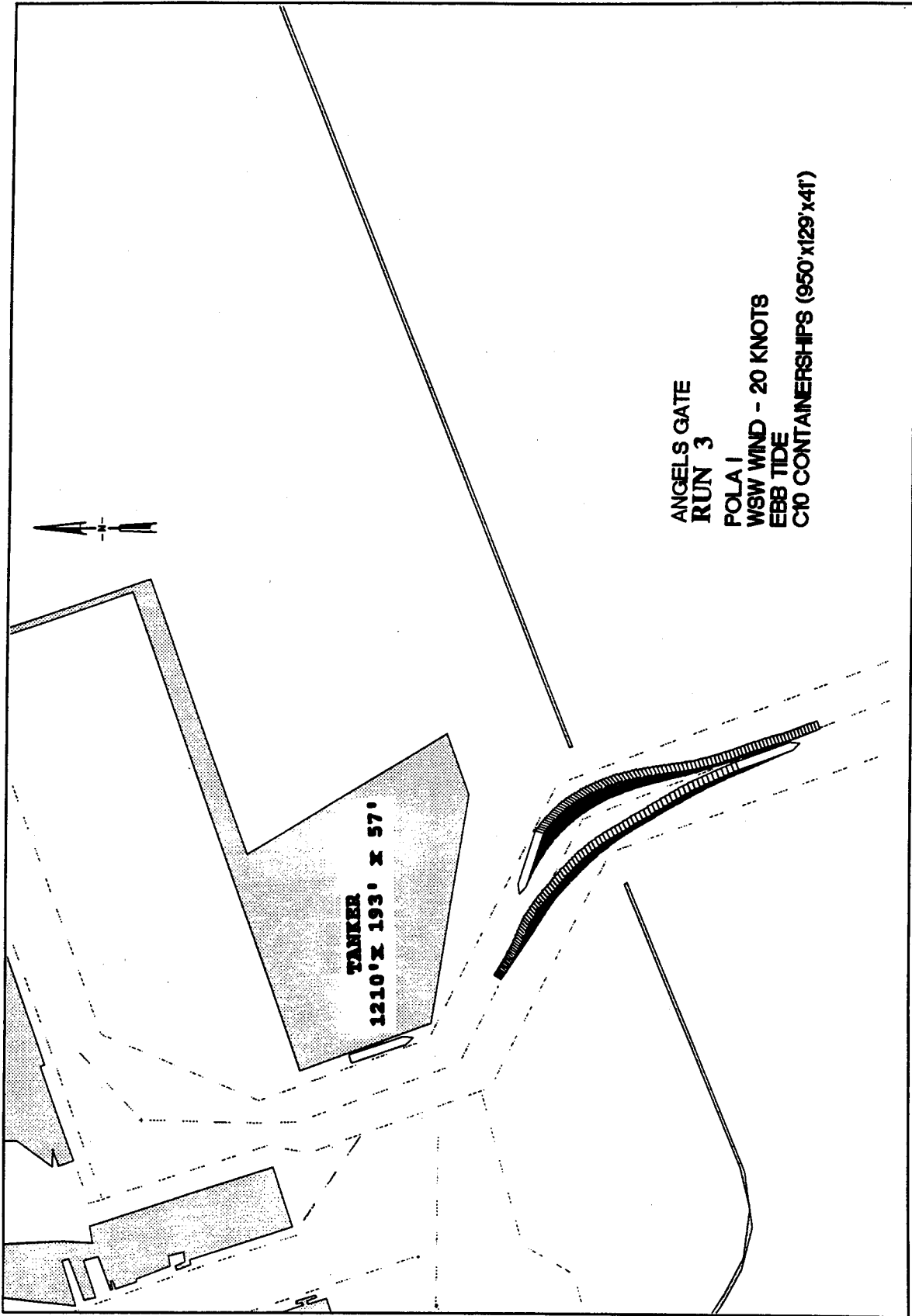
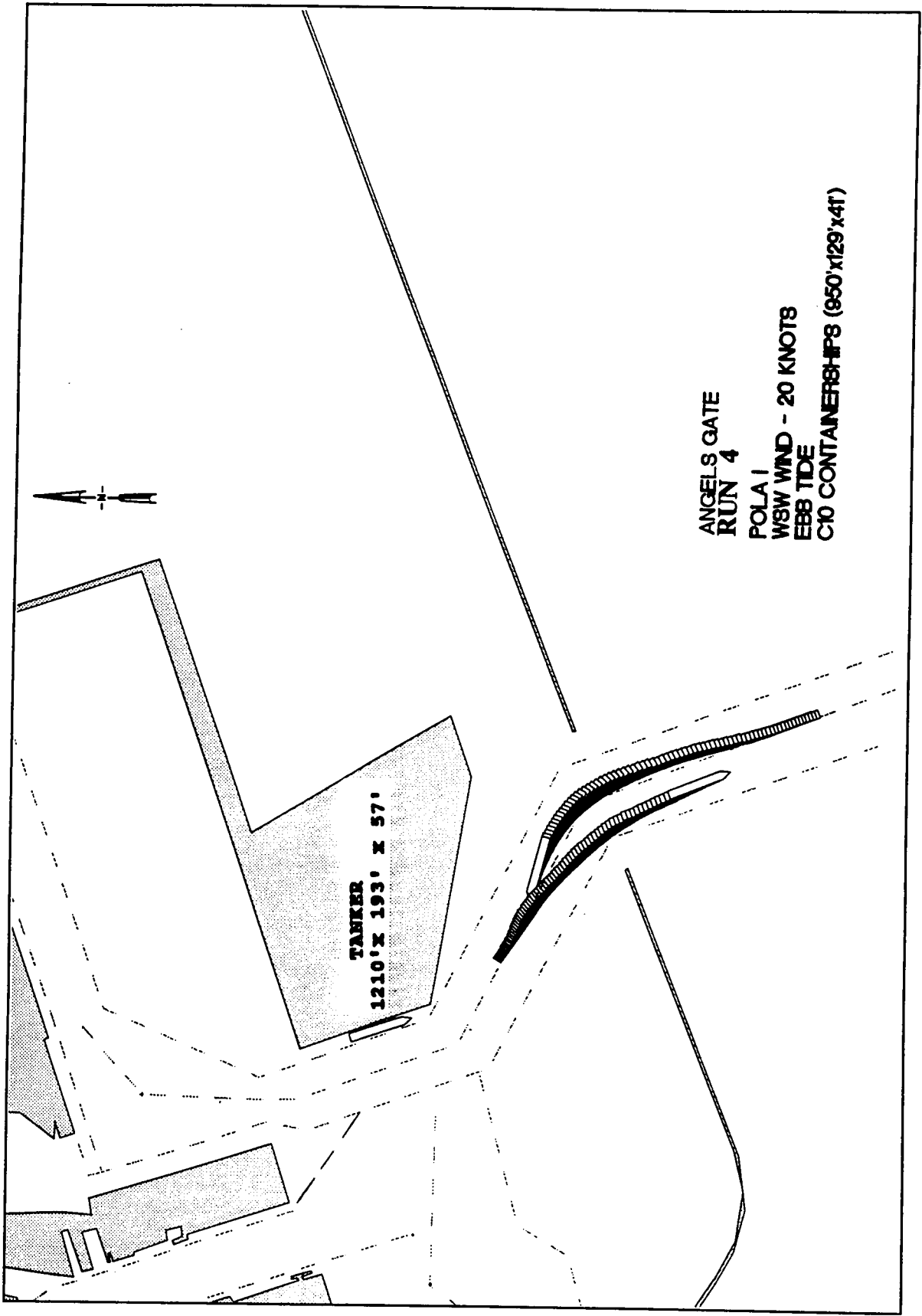

Plate 120



ANGELS GATE  
RUN 3  
POLA I  
WSW WIND - 20 KNOTS  
EBB TIDE  
C10 CONTAINERSHIPS (950' X 129' X 41')



ANGELS GATE  
RUN #4

POLA 1  
WSW WIND - 20 KNOTS  
EBB TIDE  
C10 CONTAINERSHP8 (950' X 129' X 41')

TANKER  
1210' X 193' X 57'

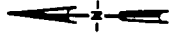

Plate 122

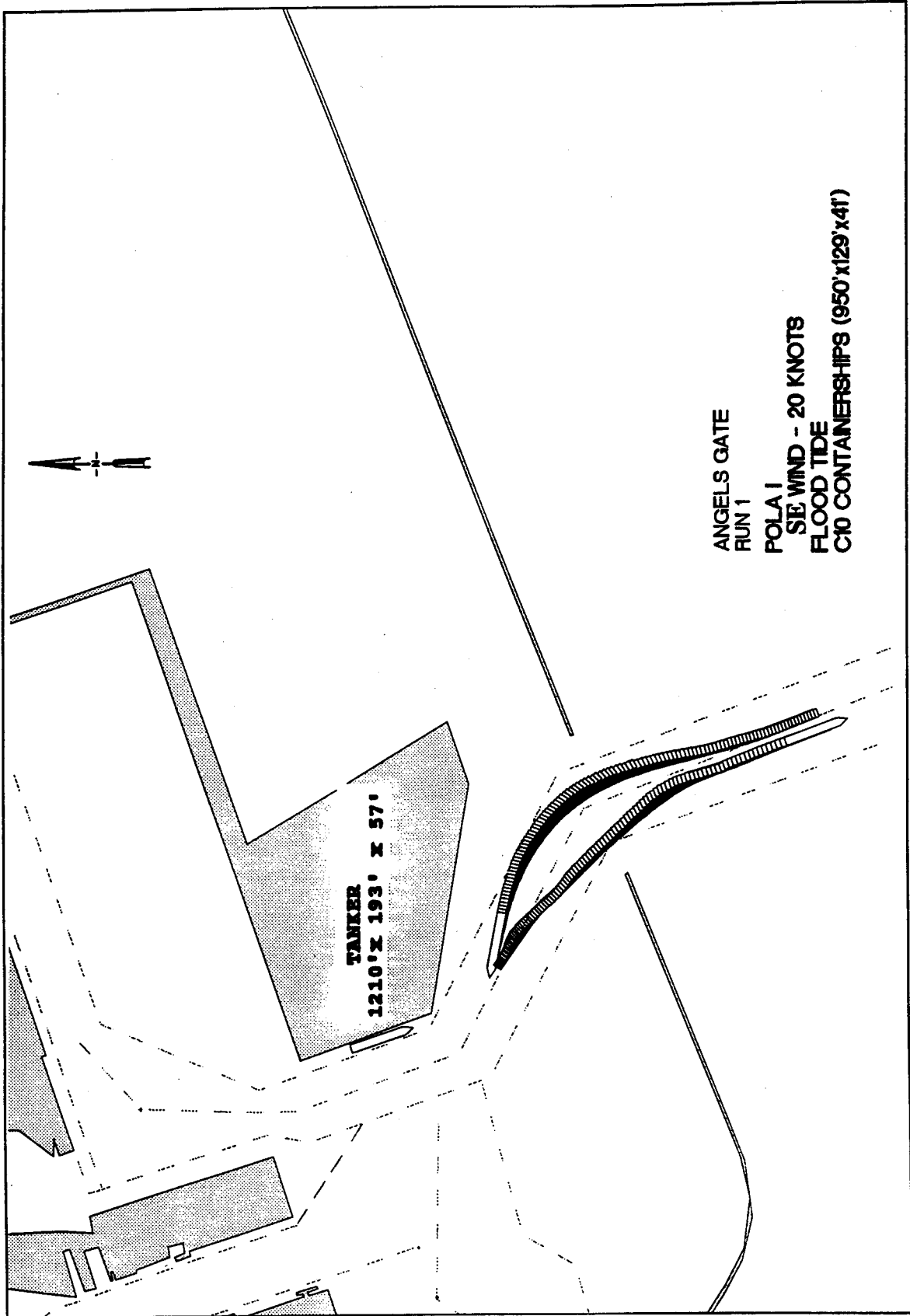

Plate 123

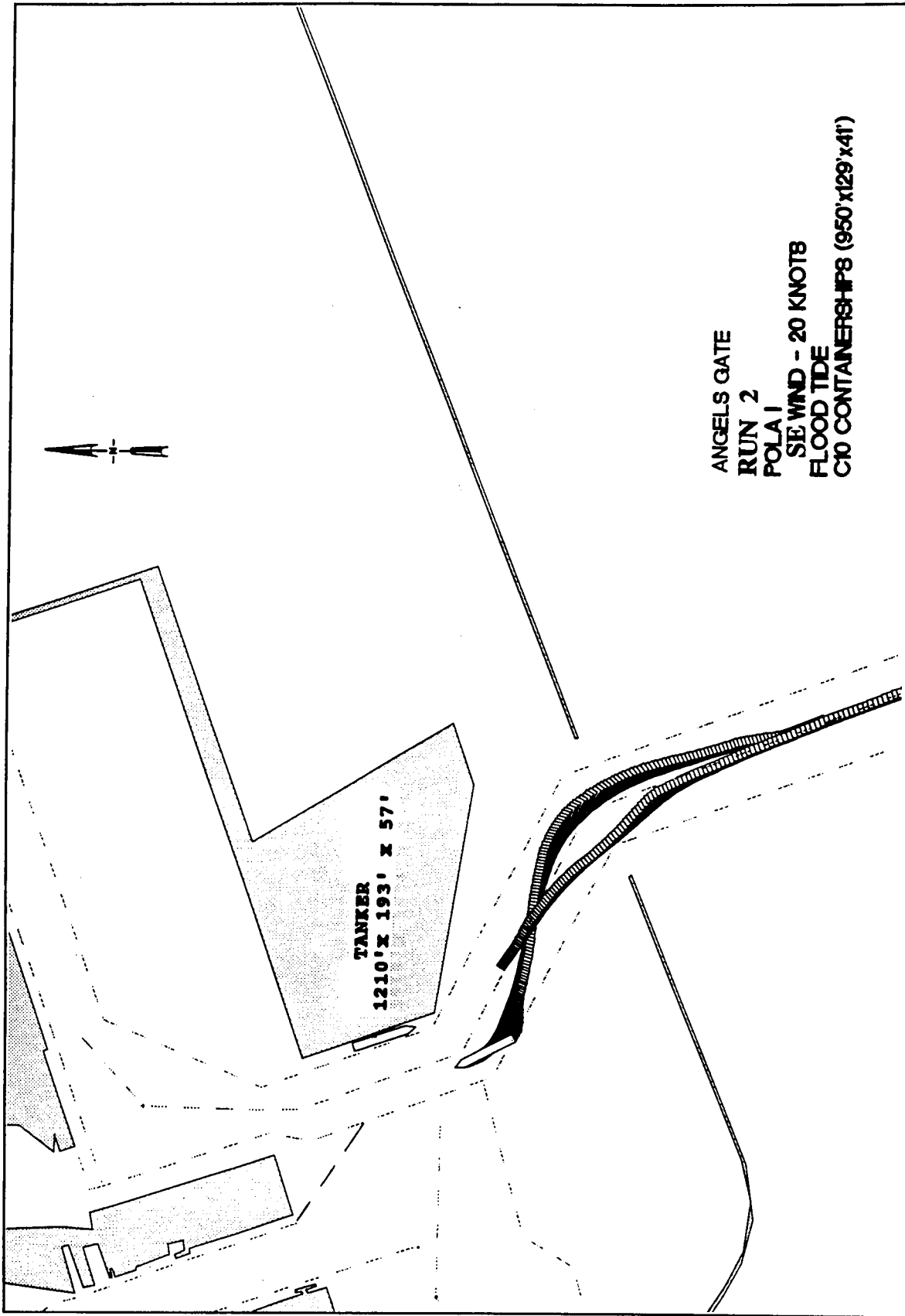

Plate 124

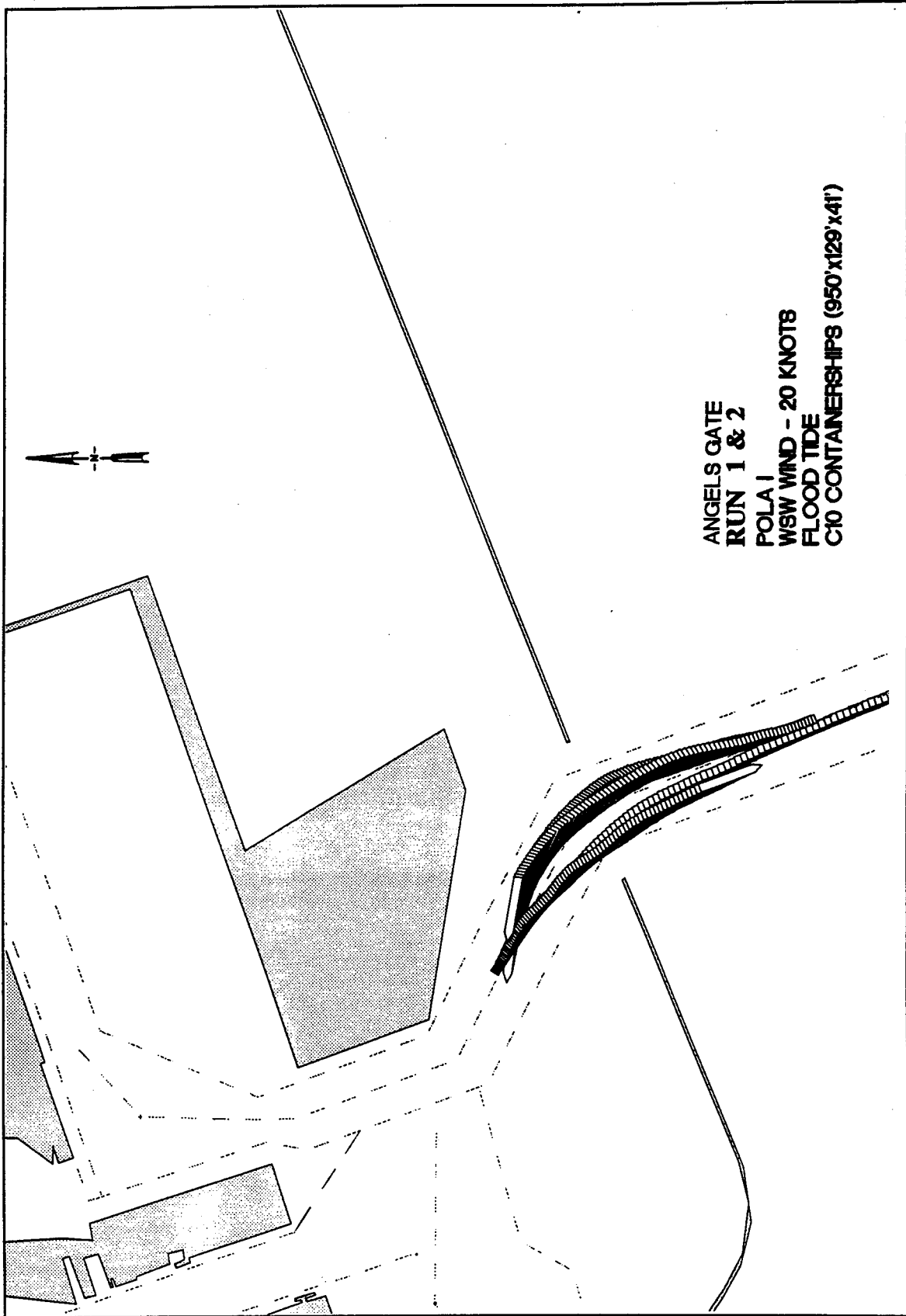

Plate 125

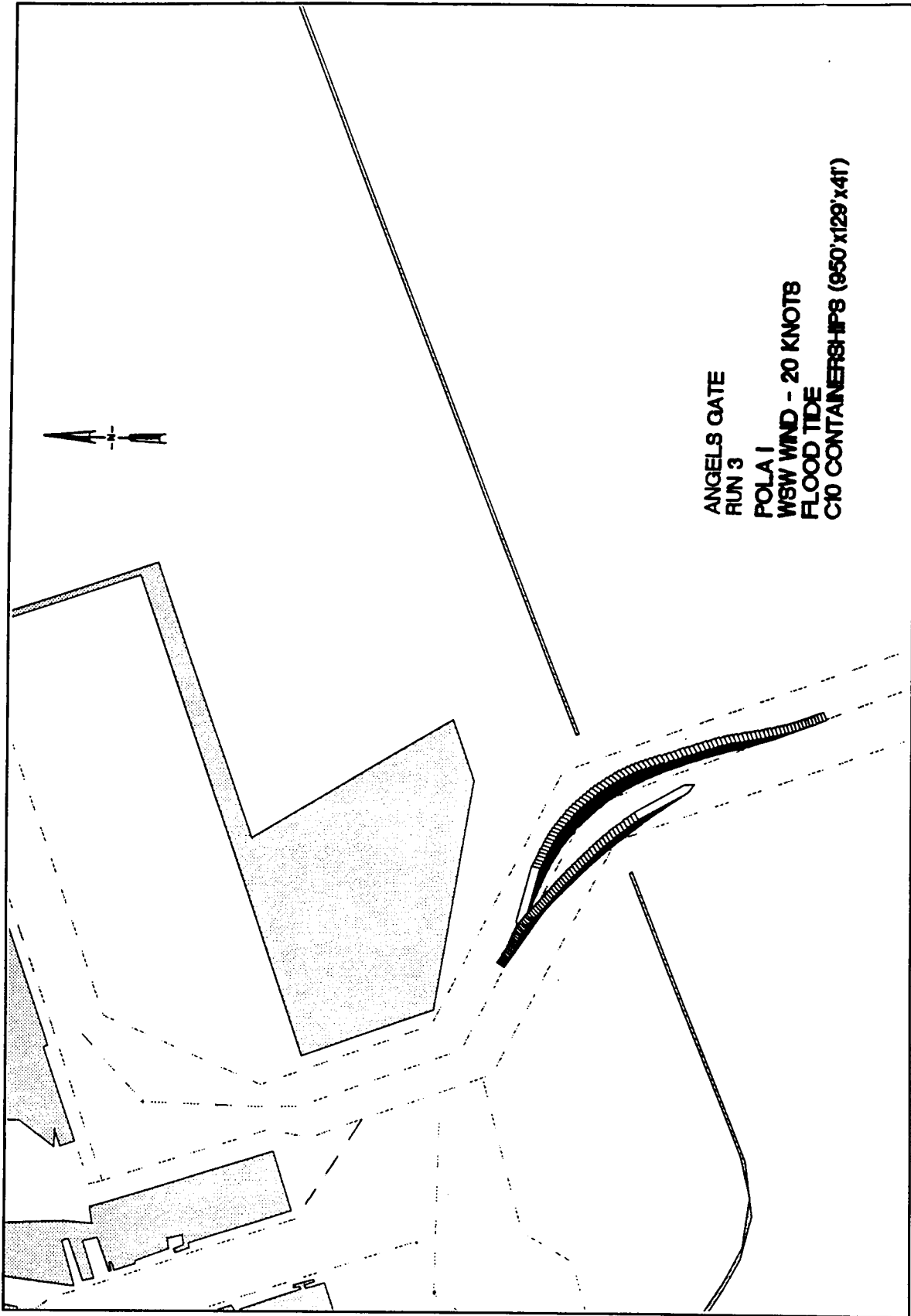

Plate 126

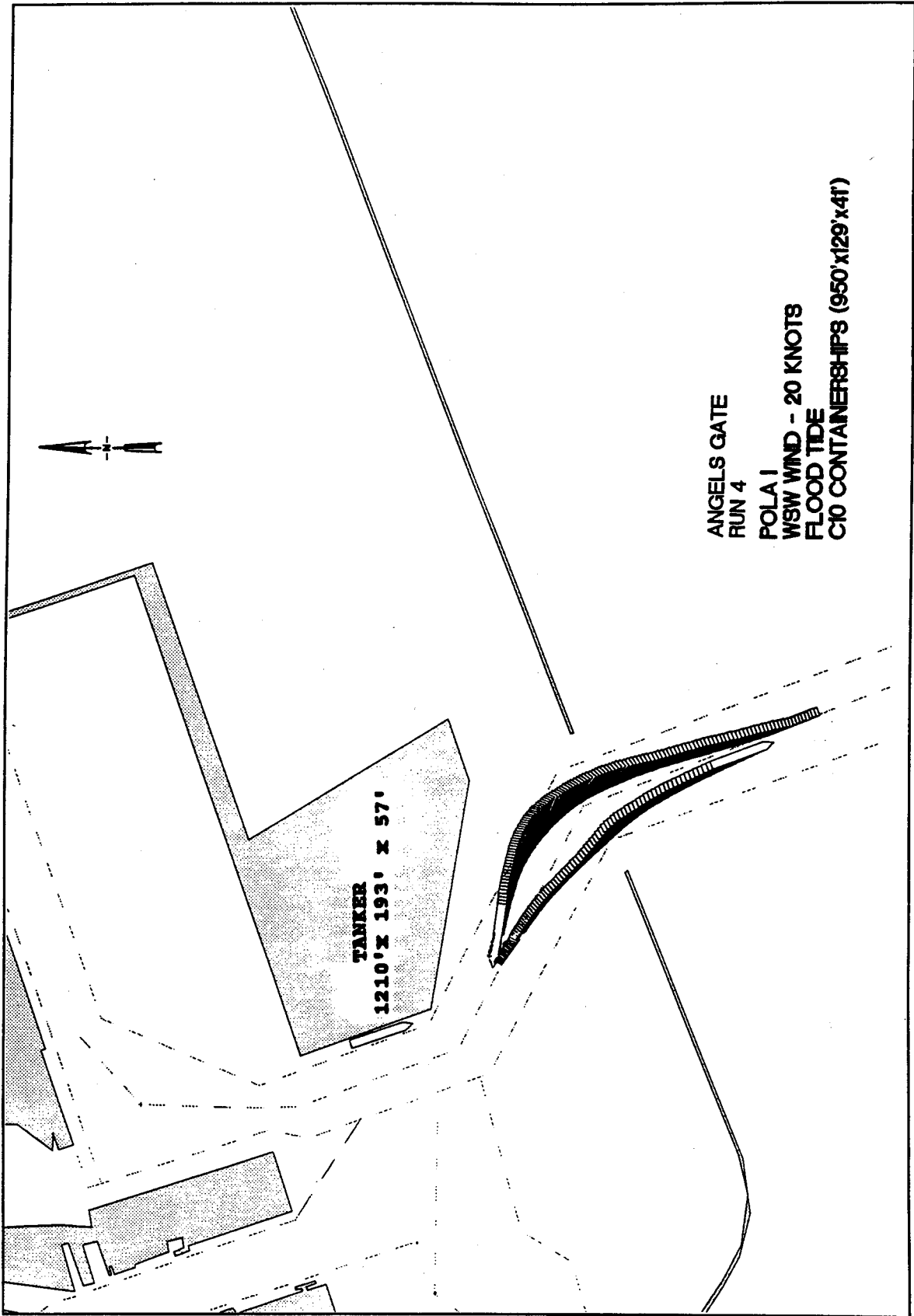
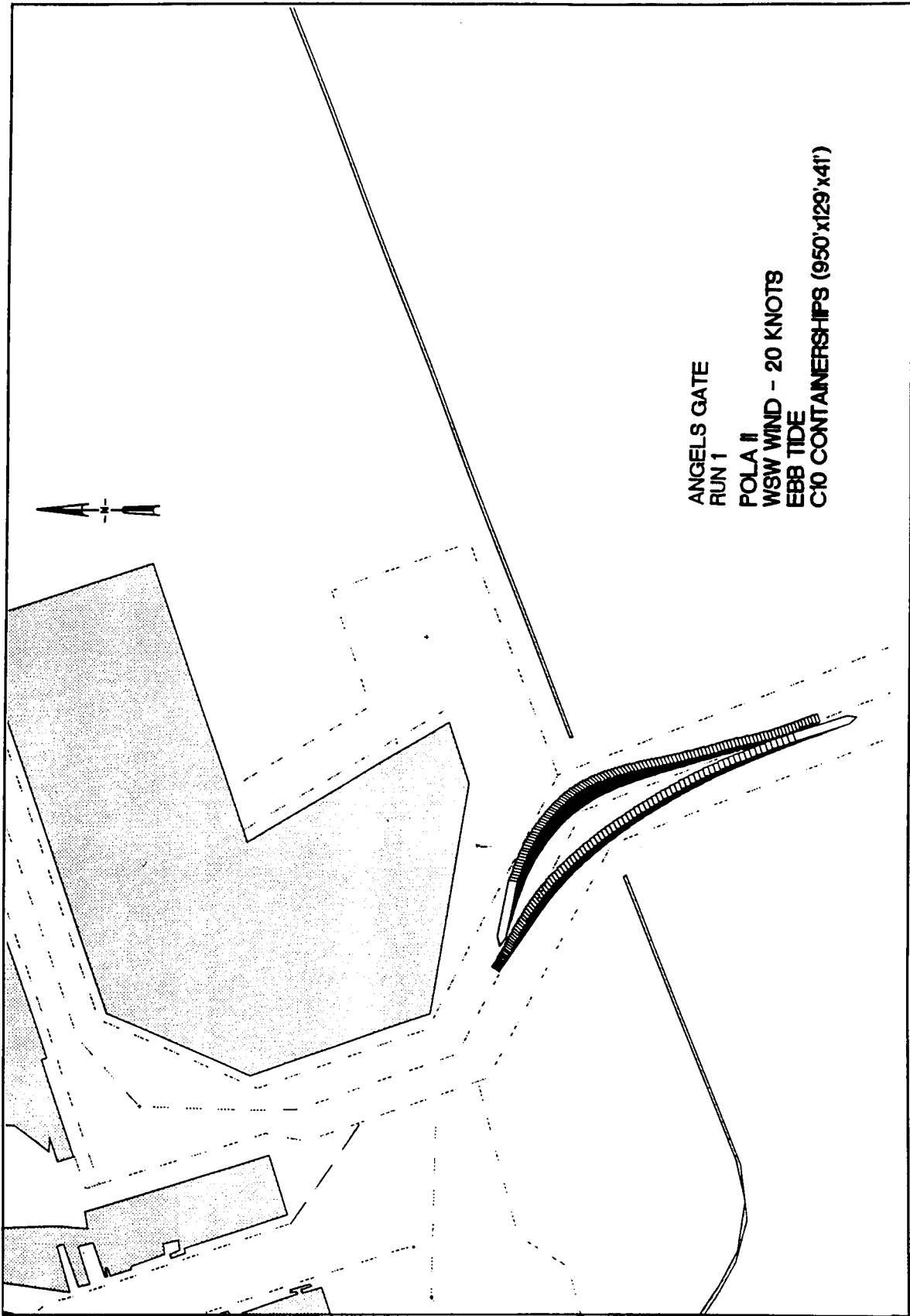
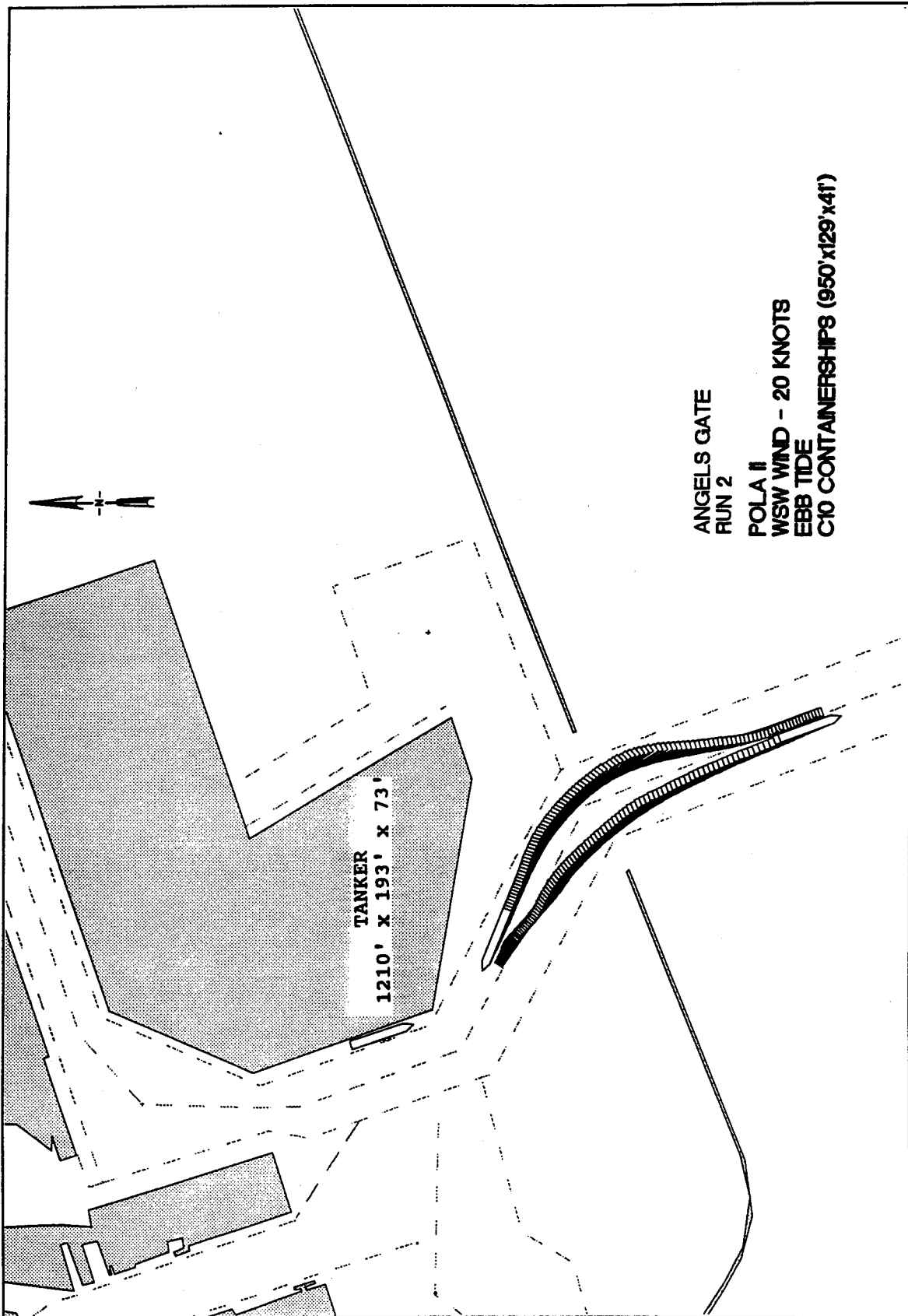

Plate 127



ANGELS GATE  
RUN 1  
POLA II  
WSW WIND - 20 KNOTS  
EBB TIDE  
C/O CONTAINERSHIPS (950'x129'x41')

Plate 128



ANGELS GATE  
RUN 2

POLA II  
WSW WIND - 20 KNOTS  
EBB TIDE  
C10 CONTAINERSHIPS (950'x129'x41')

TANKER  
1210' x 193' x 73'

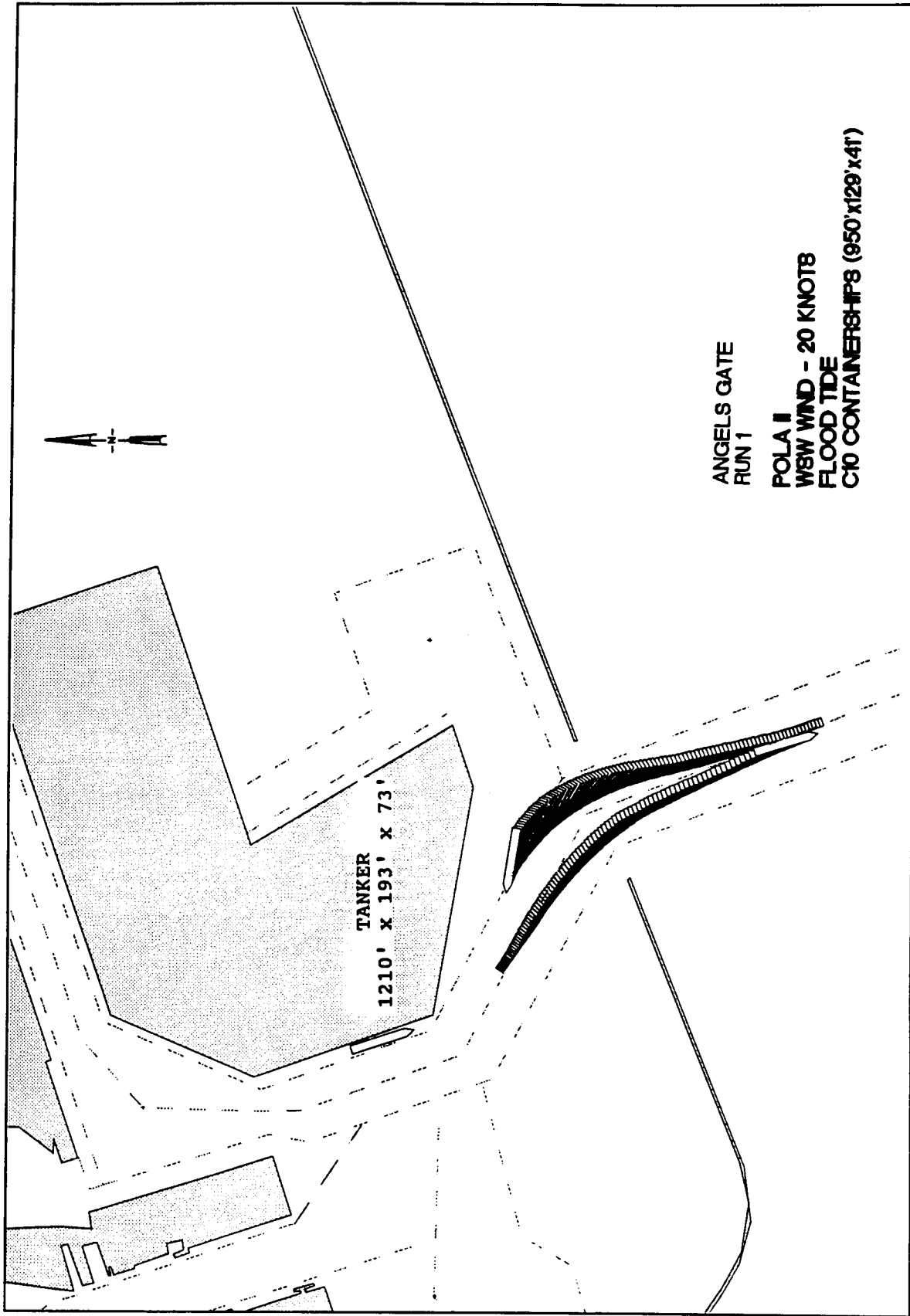
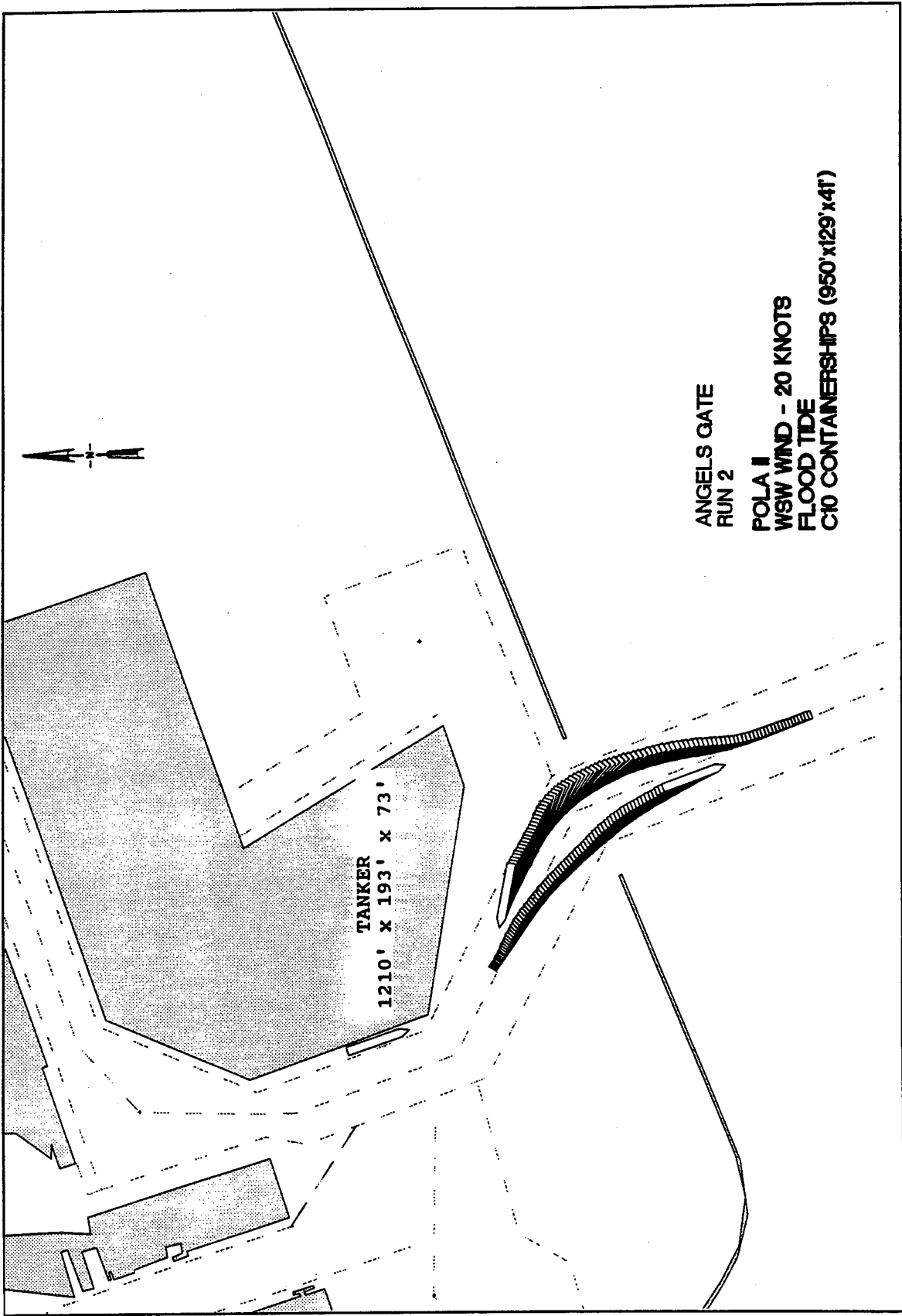

Plate 130



ANGELS GATE  
RUN 2

POLA II  
WSW WIND - 20 KNOTS  
FLOOD TIDE  
C10 CONTAINERSHIPS (950'x129'x41')

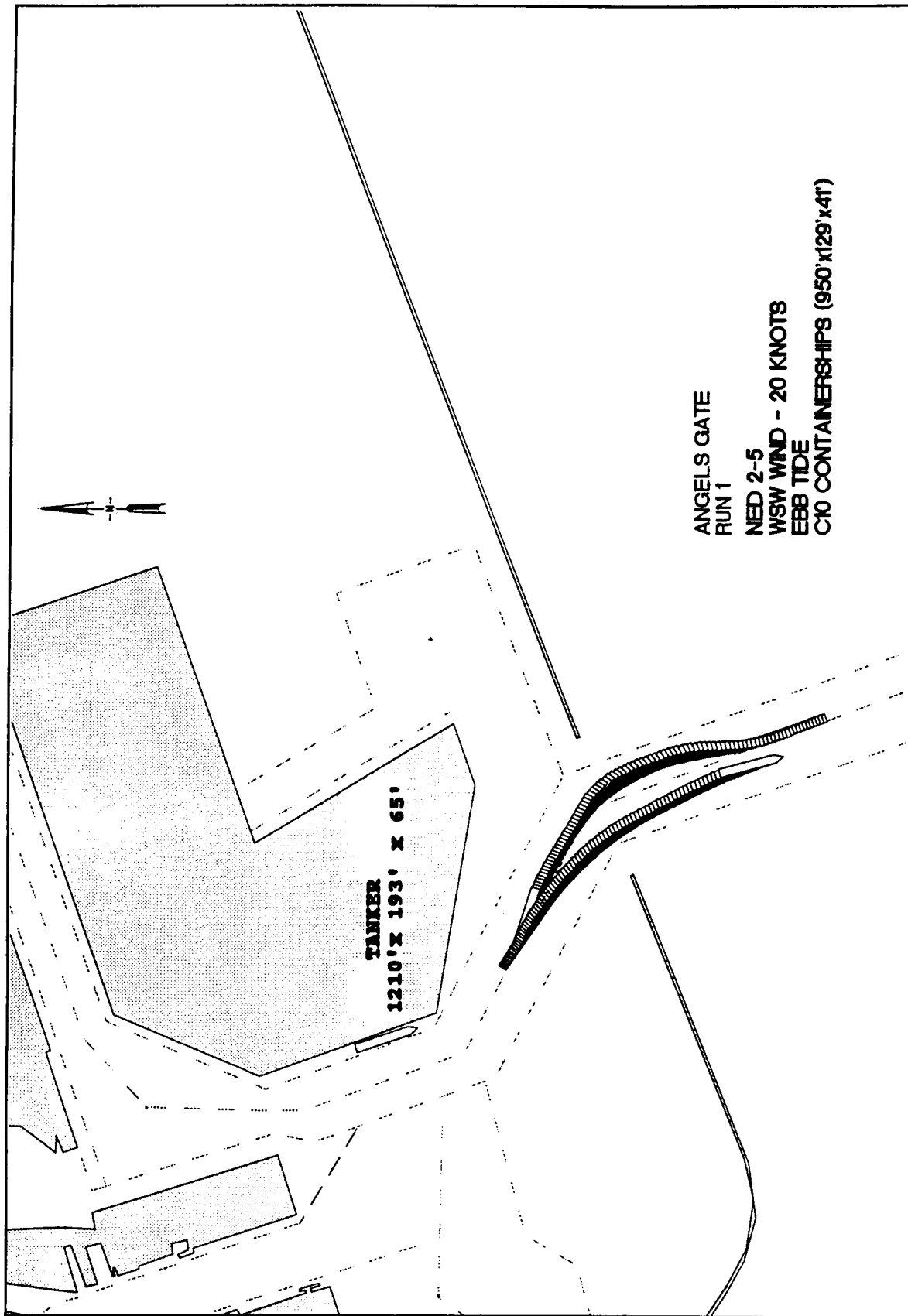
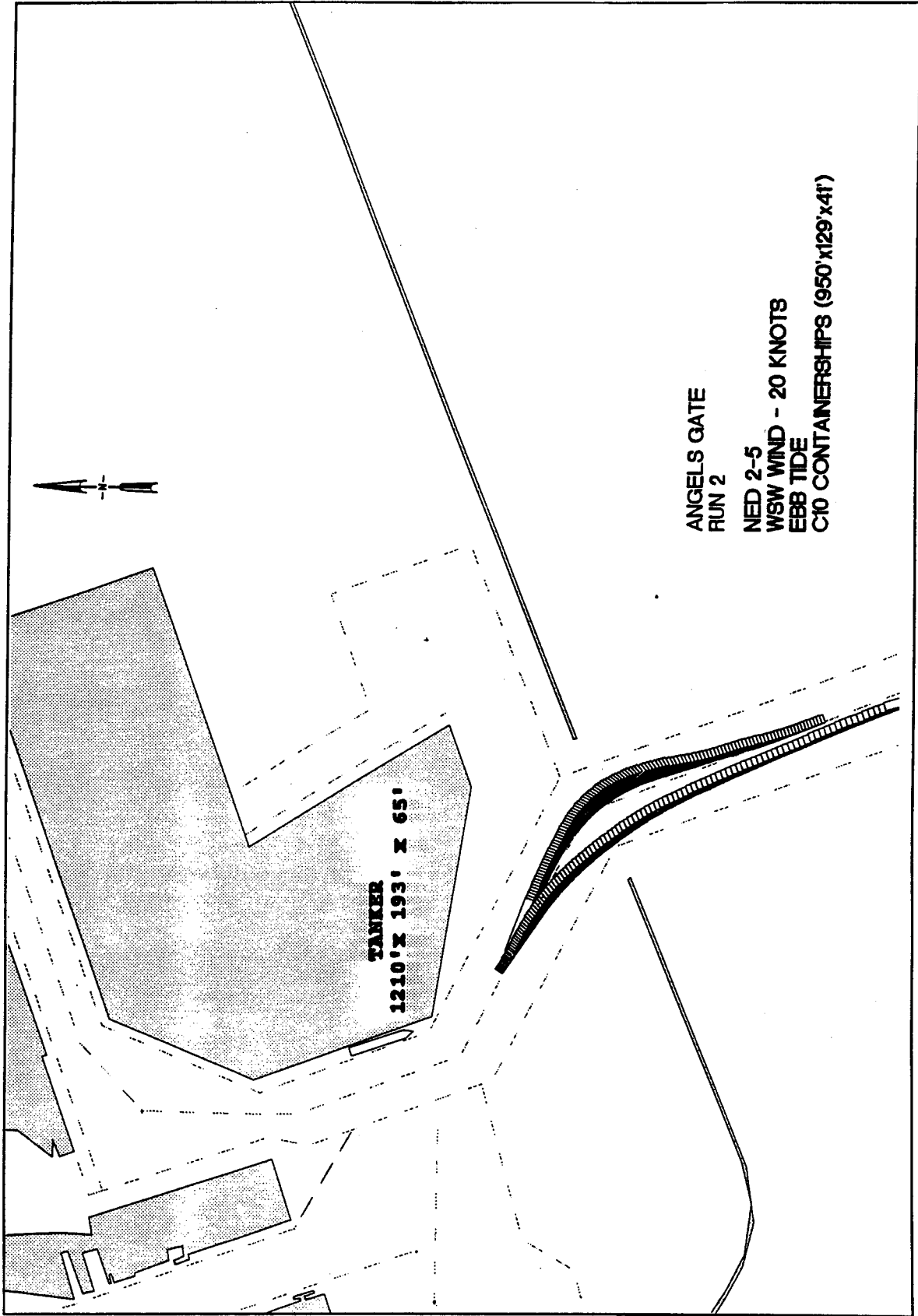

Plate 132



ANGELS GATE  
RUN 2

NED 2-5  
WSW WIND - 20 KNOTS  
EBB TIDE  
C10 CONTAINERSHIPS (950' X 129' X 41')

TANKER  
1210' X 193' X 65'

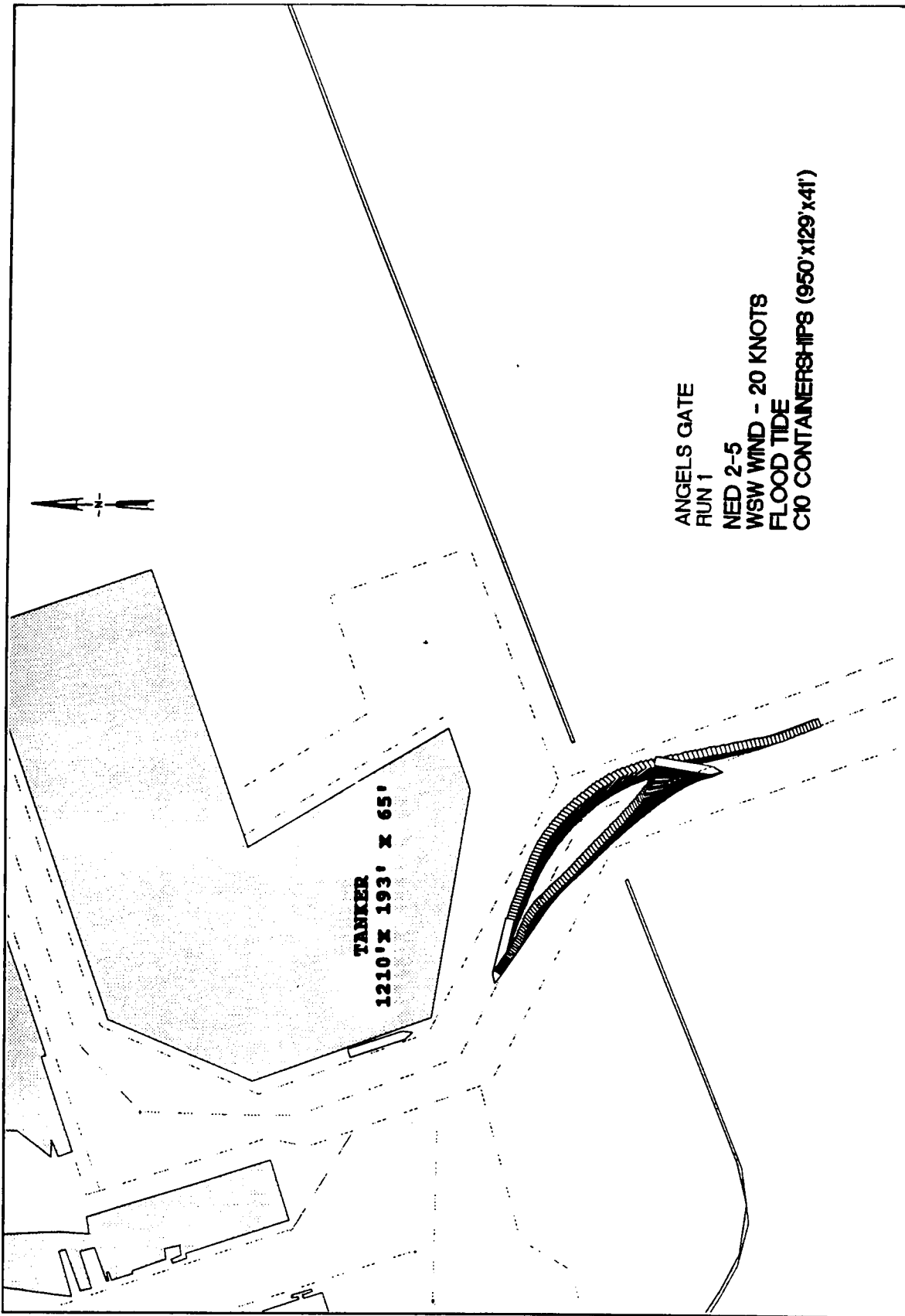
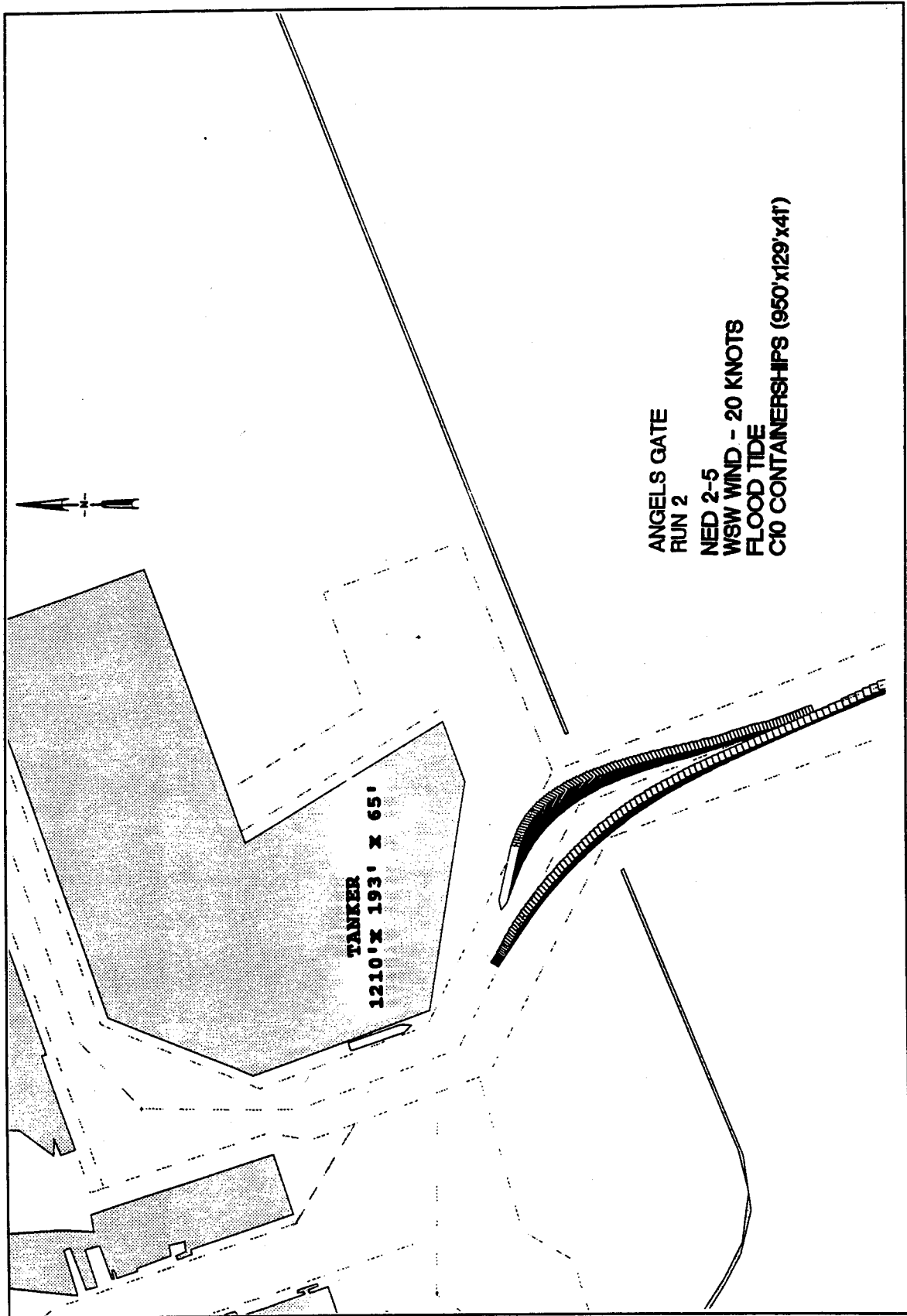

Plate 134



ANGELS GATE  
RUN 2

NED 2-5  
WSW WIND - 20 KNOTS  
FLOOD TIDE  
C10 CONTAINERSHIPS (950' X 129' X 41')

TANKER  
1210' X 193' X 65'

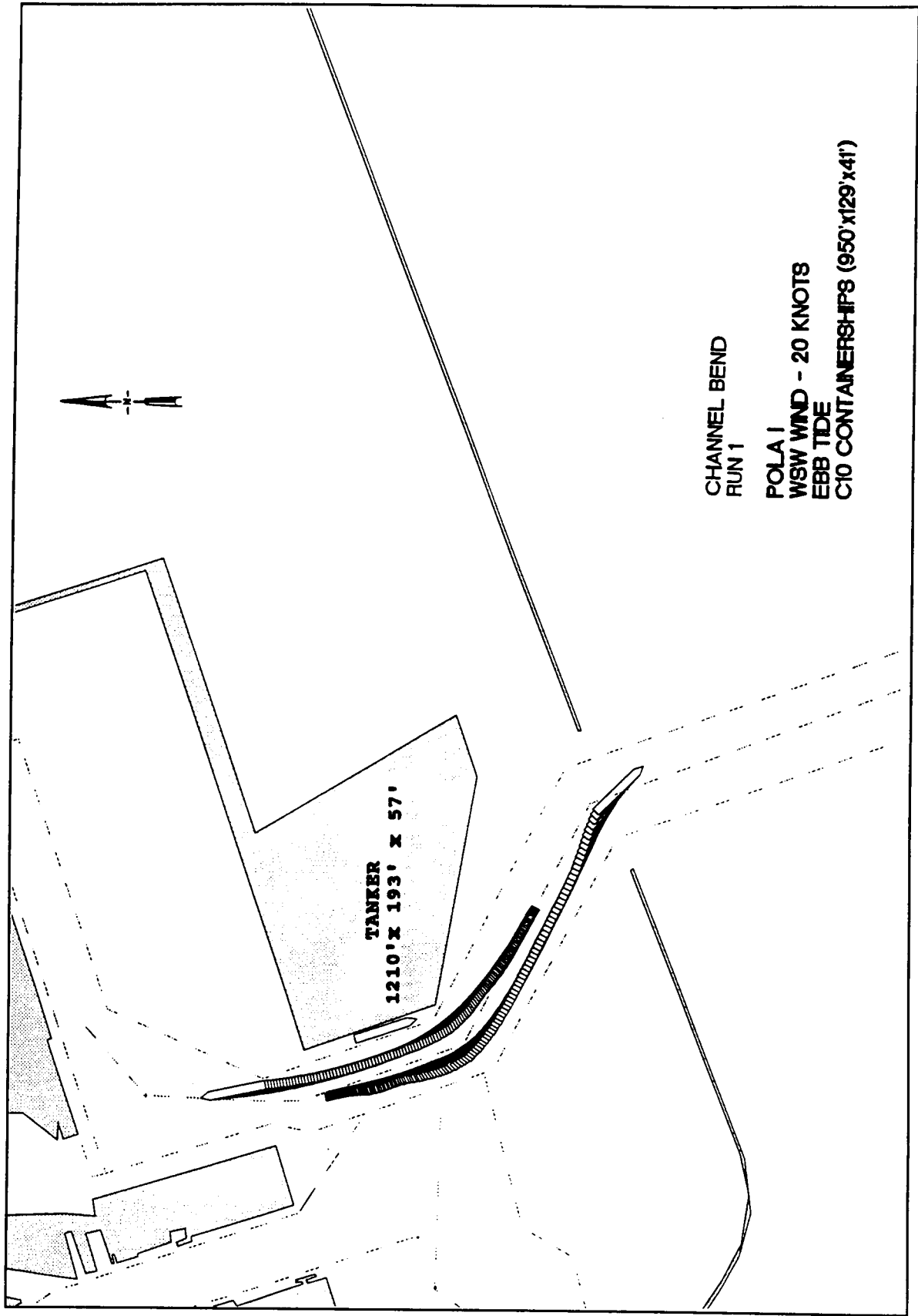
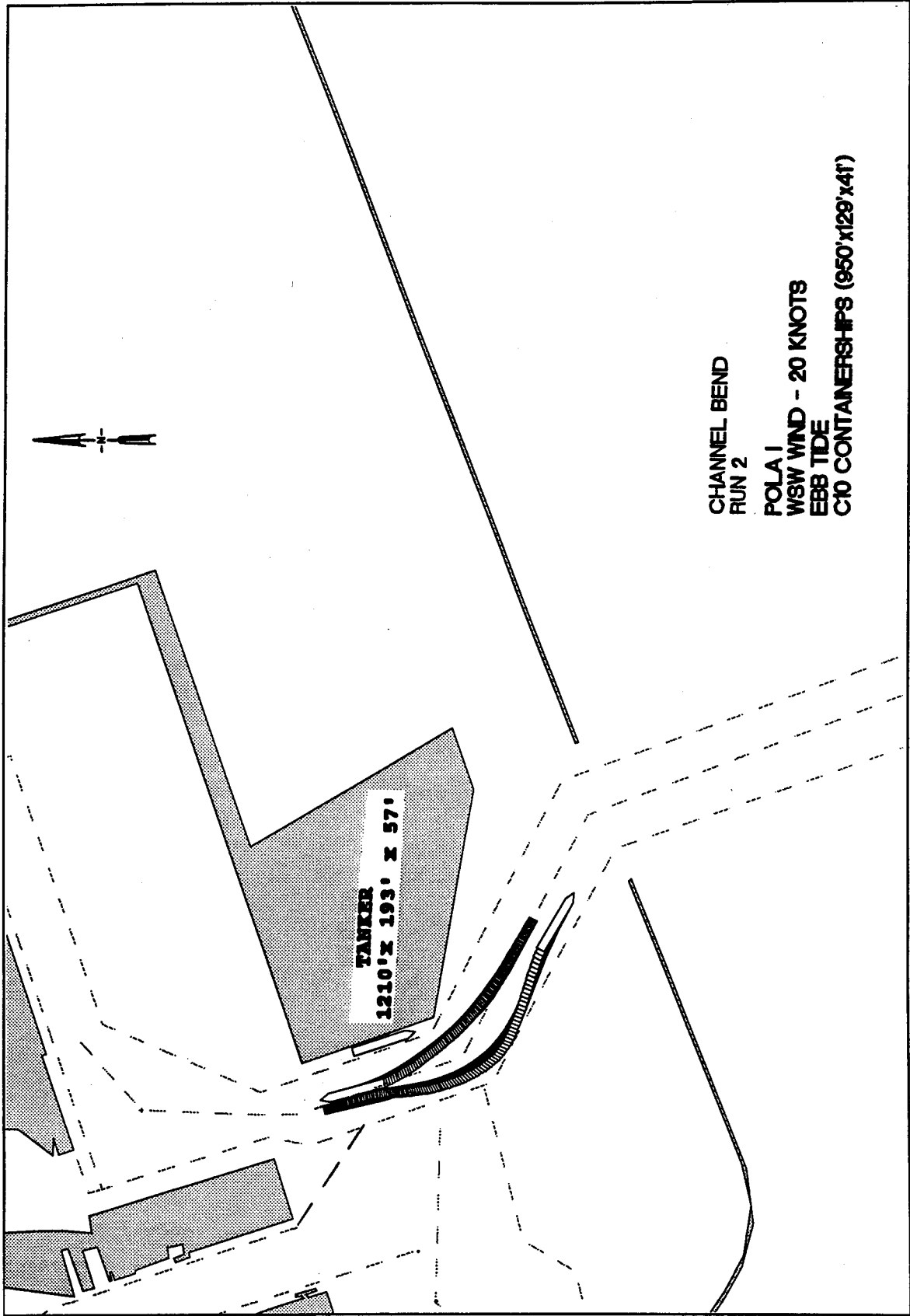

Plate 136



CHANNEL BEND  
RUN 2

POLA I  
WSW WIND - 20 KNOTS  
EBB TIDE  
C/O CONTAINERSHIPS (950'x129'x41')

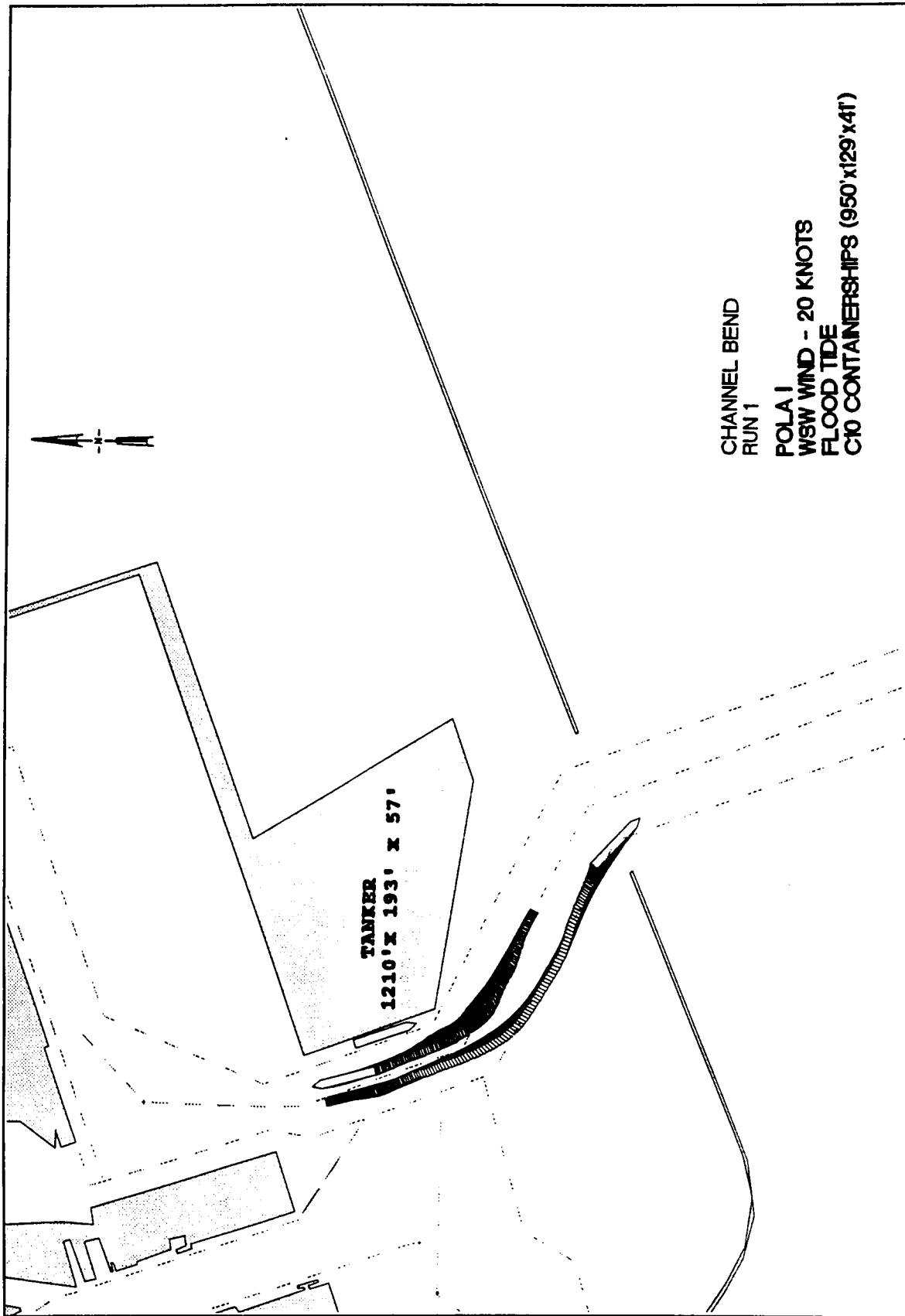
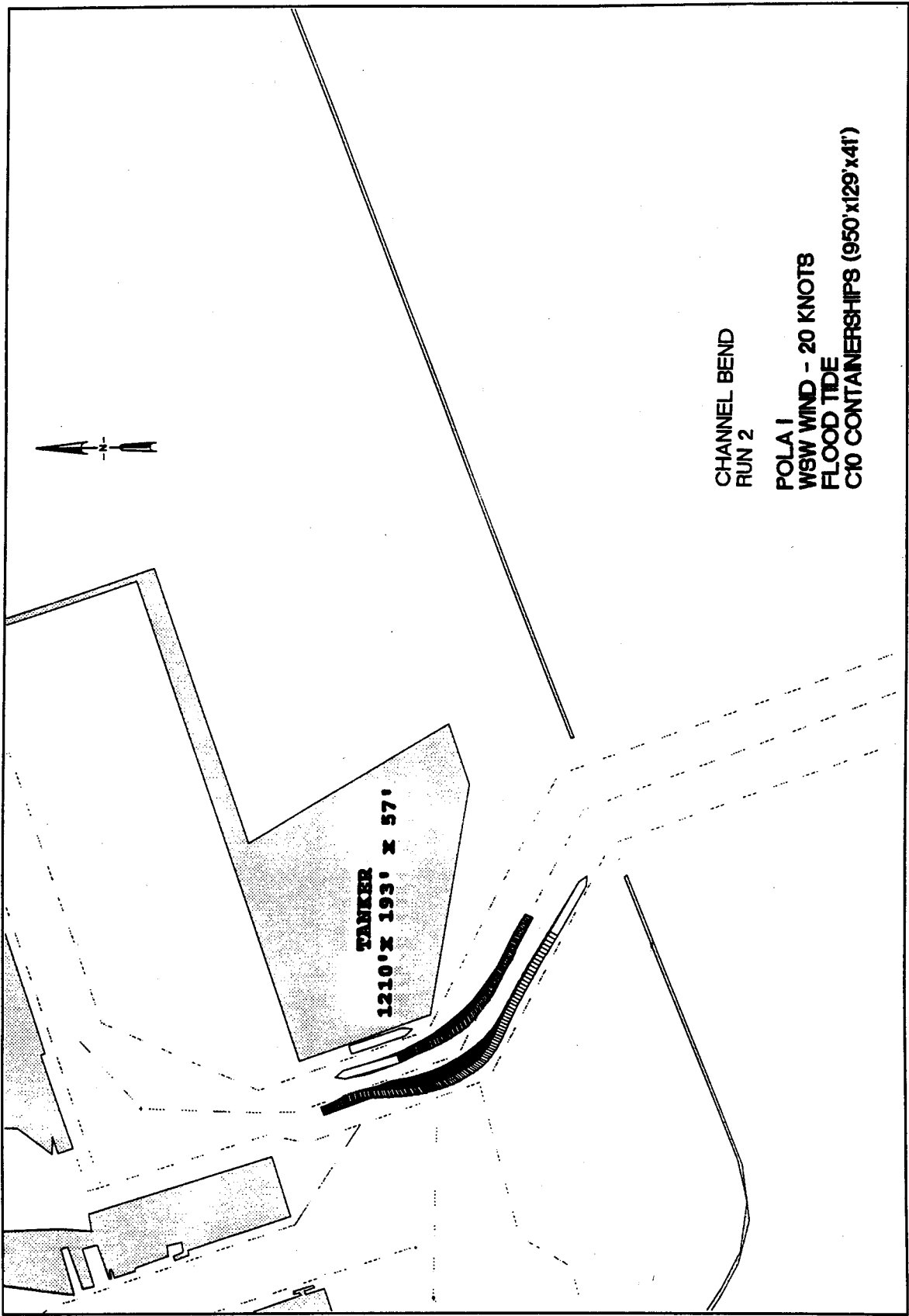
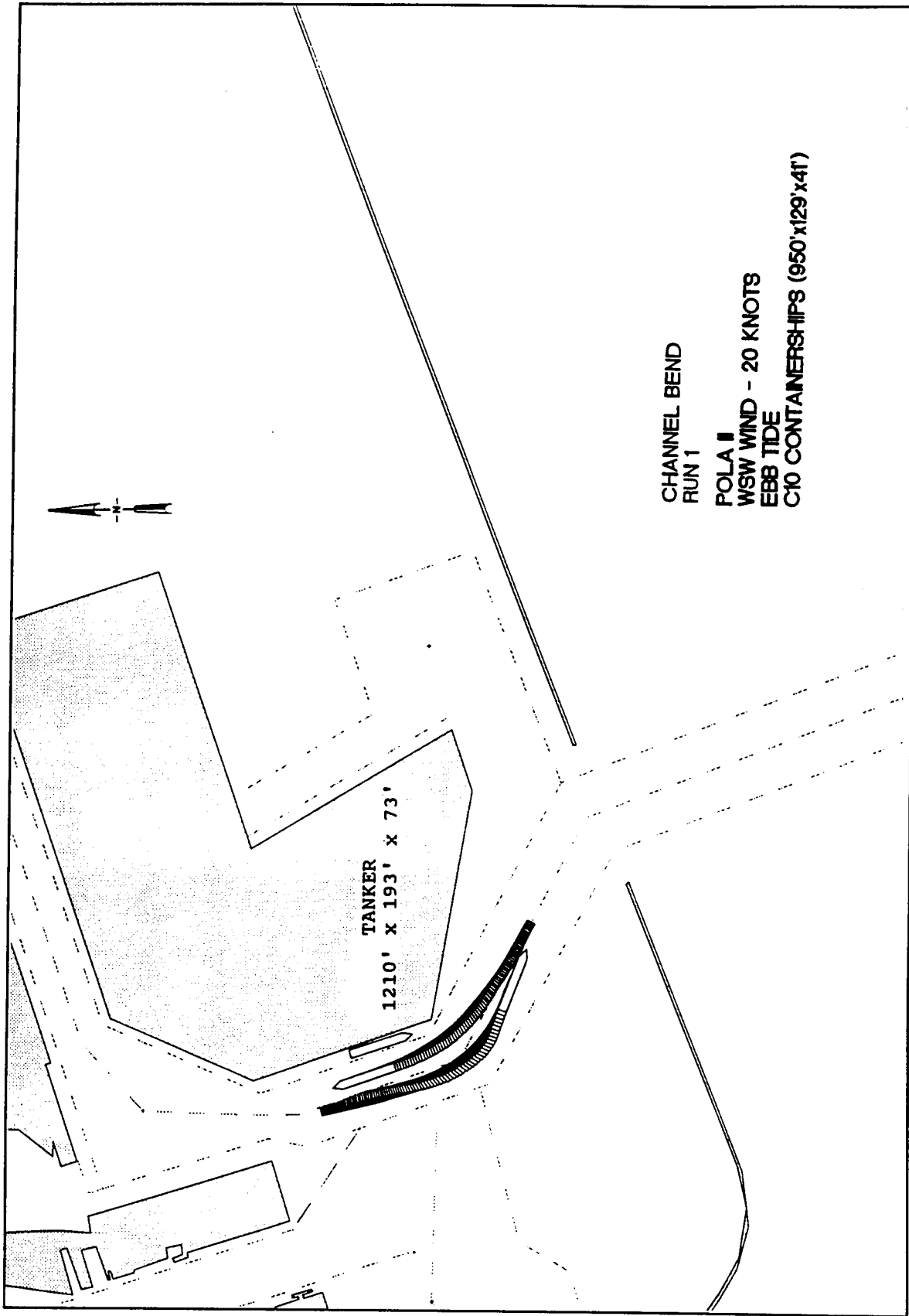

Plate 138





CHANNEL BEND  
RUN 1

POLA II  
WSW WIND - 20 KNOTS  
EBB TIDE  
C10 CONTAINERSHIPS (950'x129'x41')

TANKER  
1210' x 193' x 73'

Plate 140

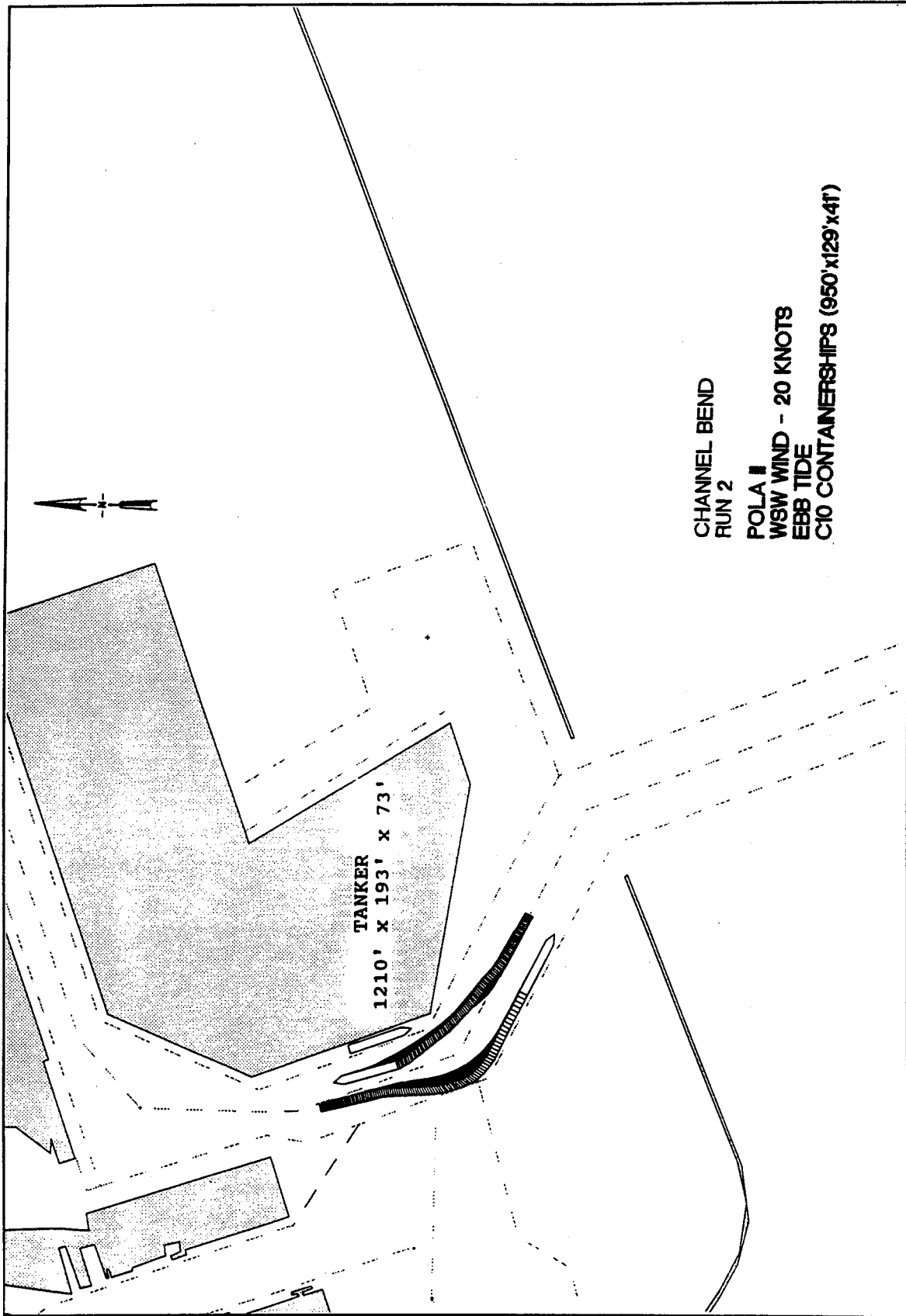

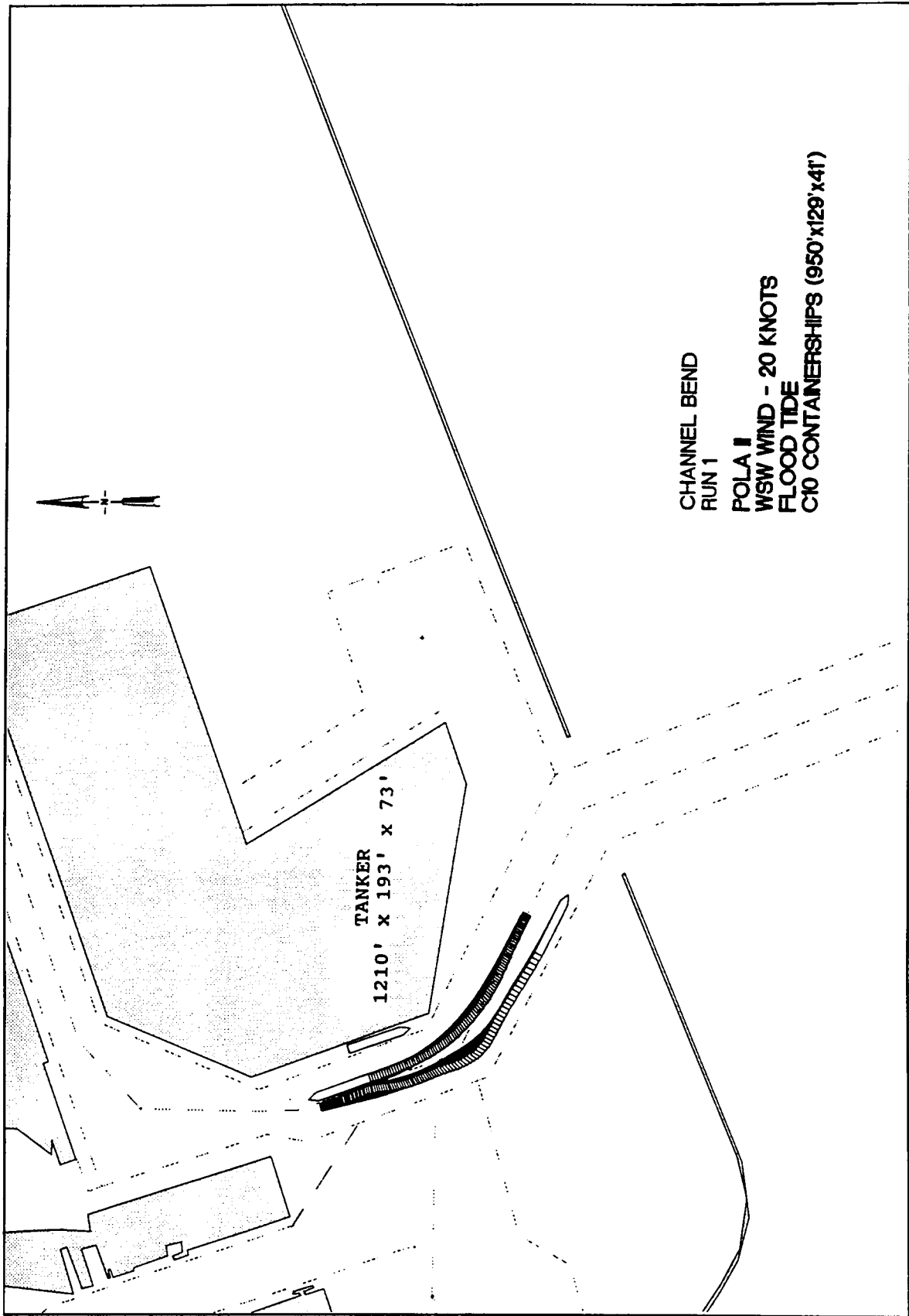
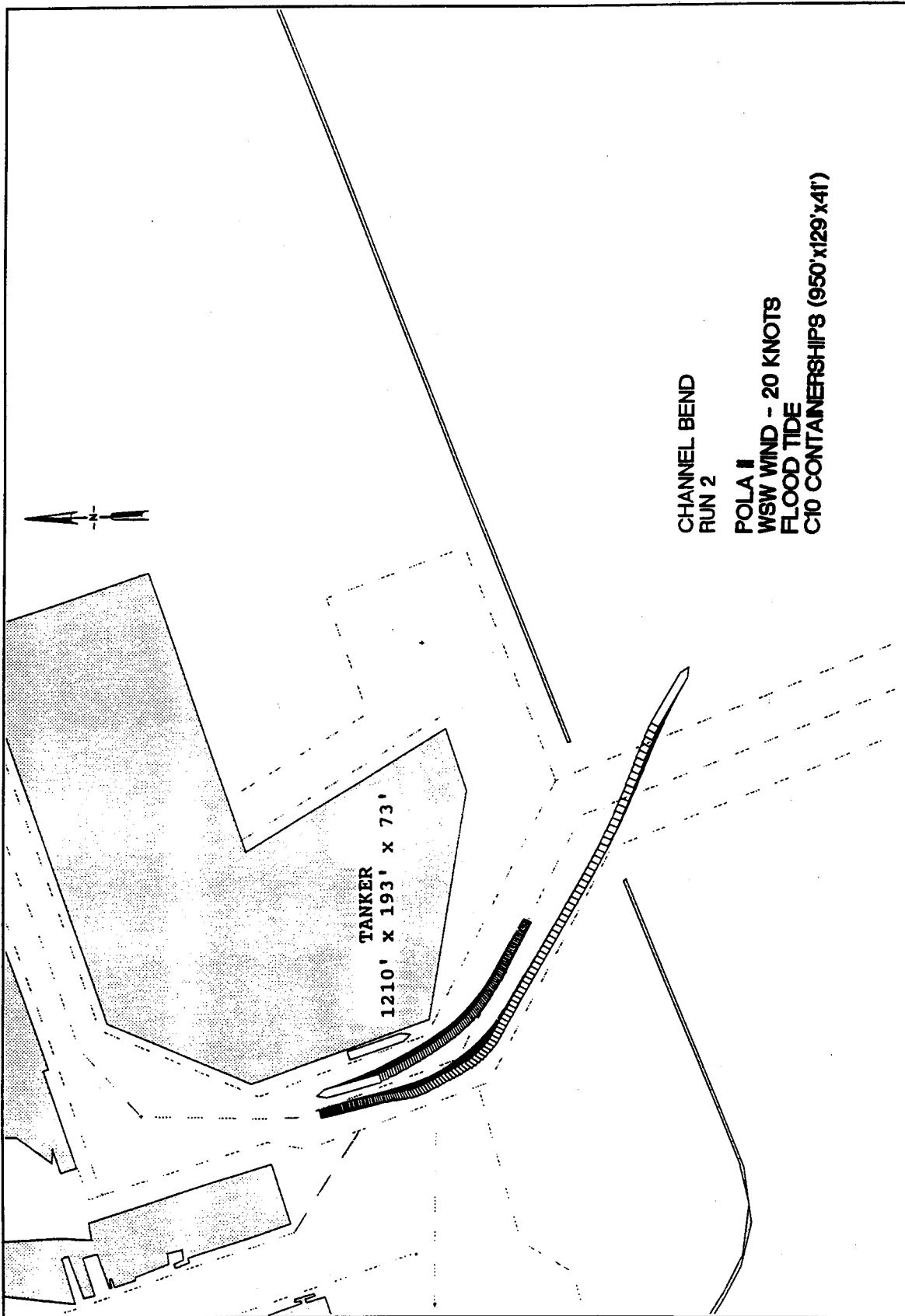
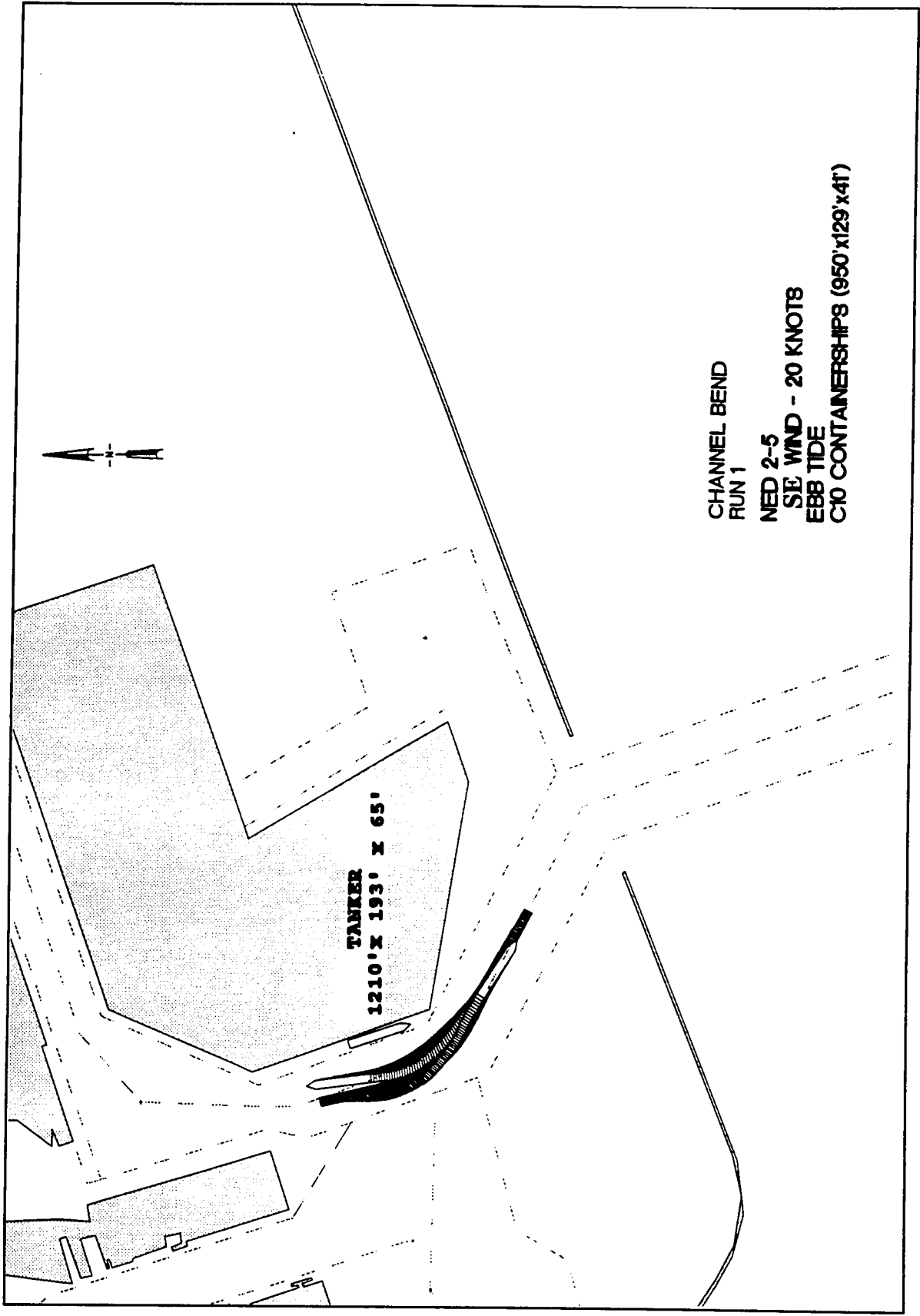

Plate 142





CHANNEL BEND  
RUN 1

NED 2-5  
S/E WIND - 20 KNOTS  
EBB TIDE  
C10 CONTAINERSHIPS (950'x129'x41')

TANKER  
1210' X 193' X 65'

52

Plate 144

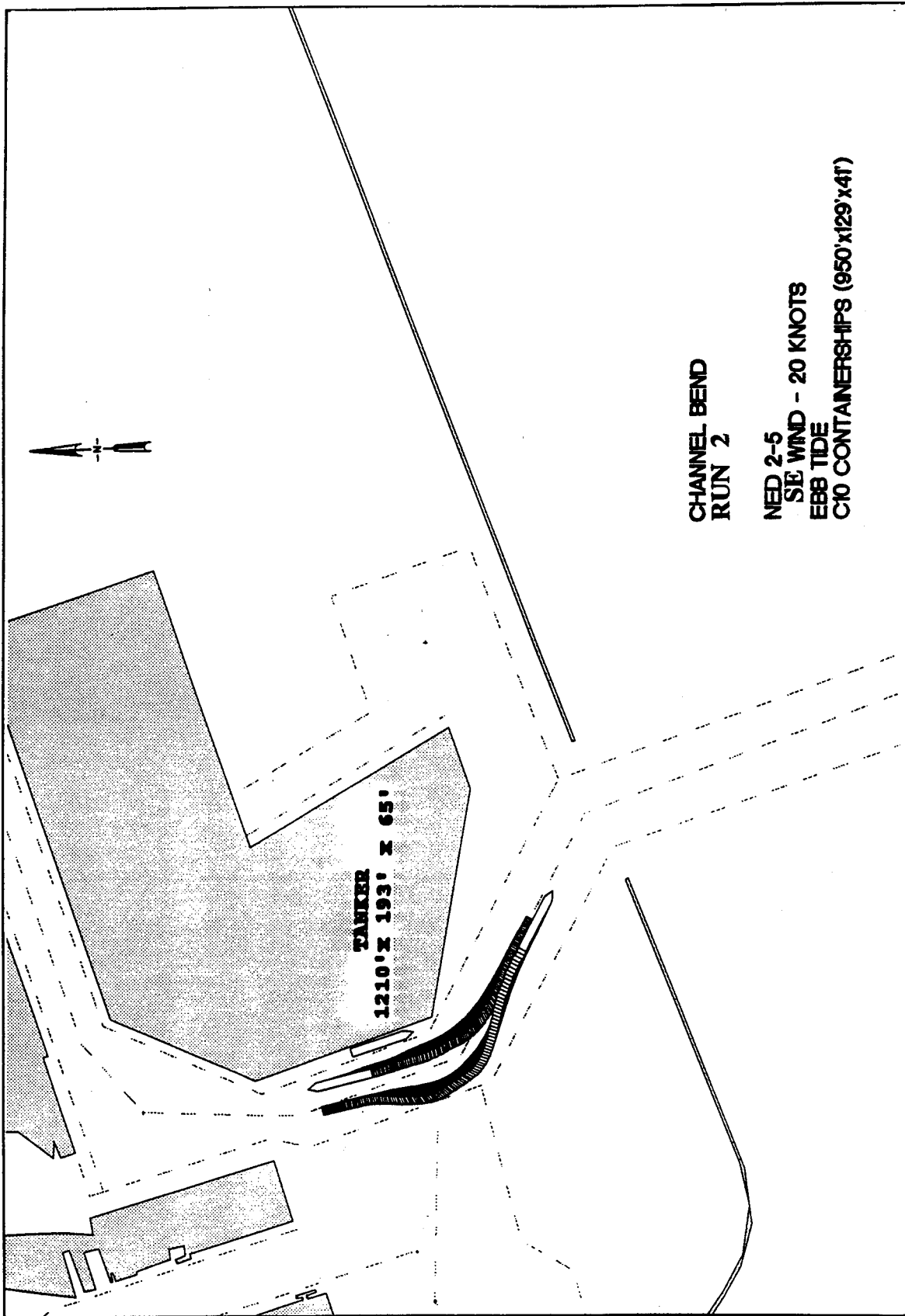

CHANNEL BEND  
RUN 2

NED 2-5  
SE WIND - 20 KNOTS  
EBB TIDE  
C10 CONTAINERSHIPS (950'x129'x41')

TANKER  
1210' X 193' X 65'

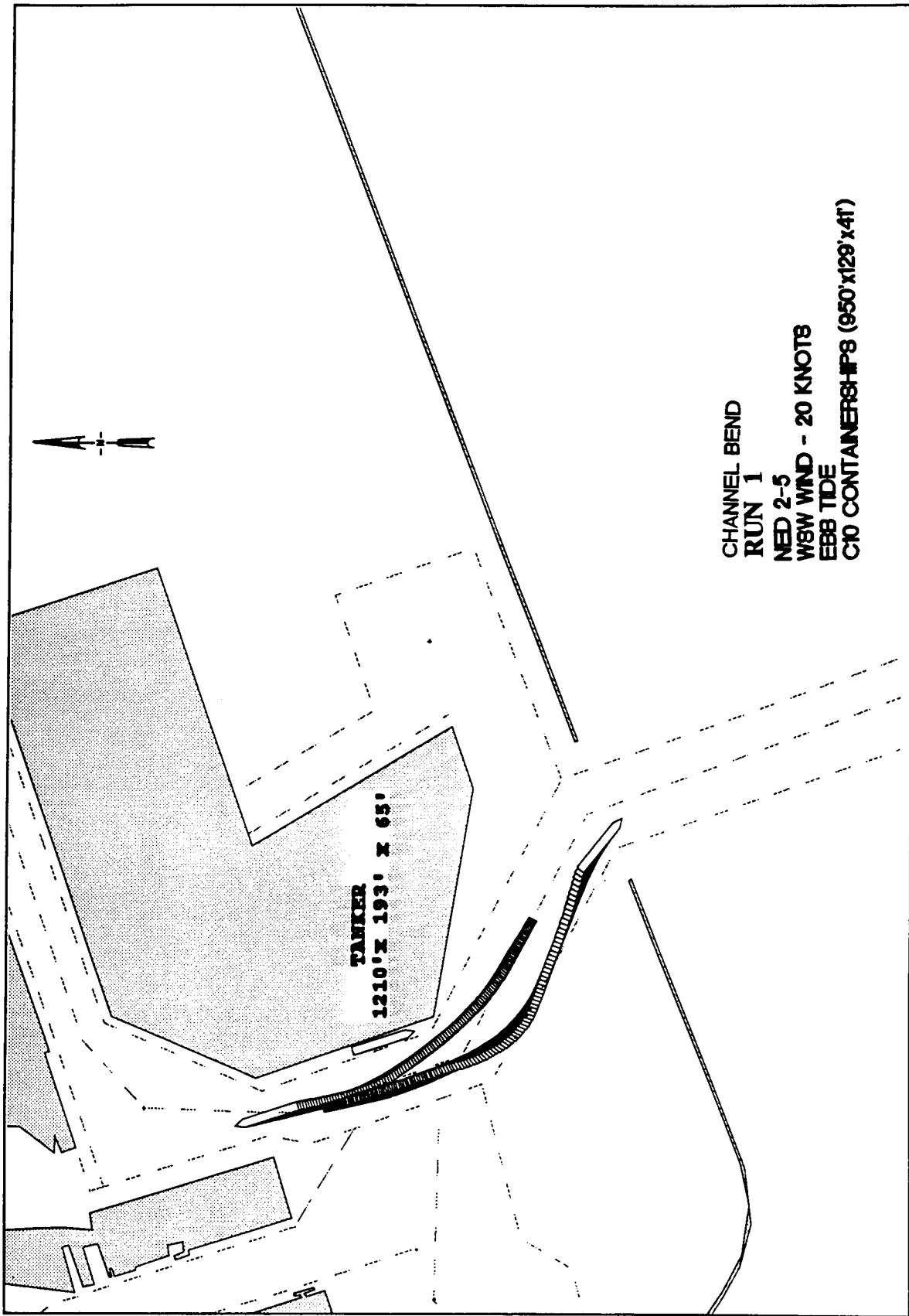

CHANNEL BEND  
RUN 1  
NEE 2-5  
WSW WIND - 20 KNOTS  
EBB TIDE  
C10 CONTAINERSHIPS (950' X 129' X 41')

TANKER  
1210' X 193' X 65'

Plate 146

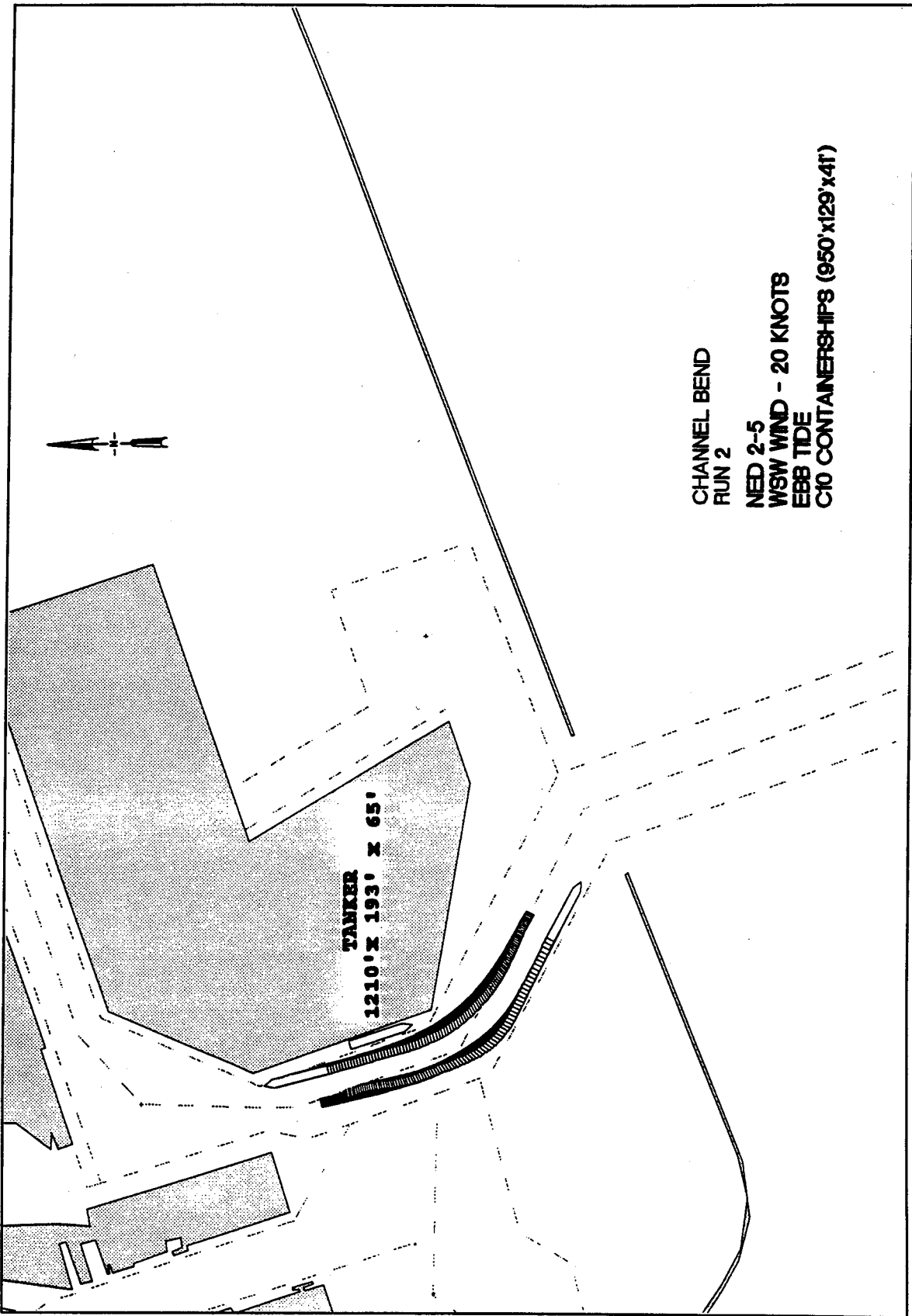

CHANNEL BEND  
RUN 2

NEE 2-5  
WSW WIND - 20 KNOTS  
EBB TIDE  
C10 CONTAINERSHIPS (950'x129'x41')

TANKER  
1210' X 193' X 65'

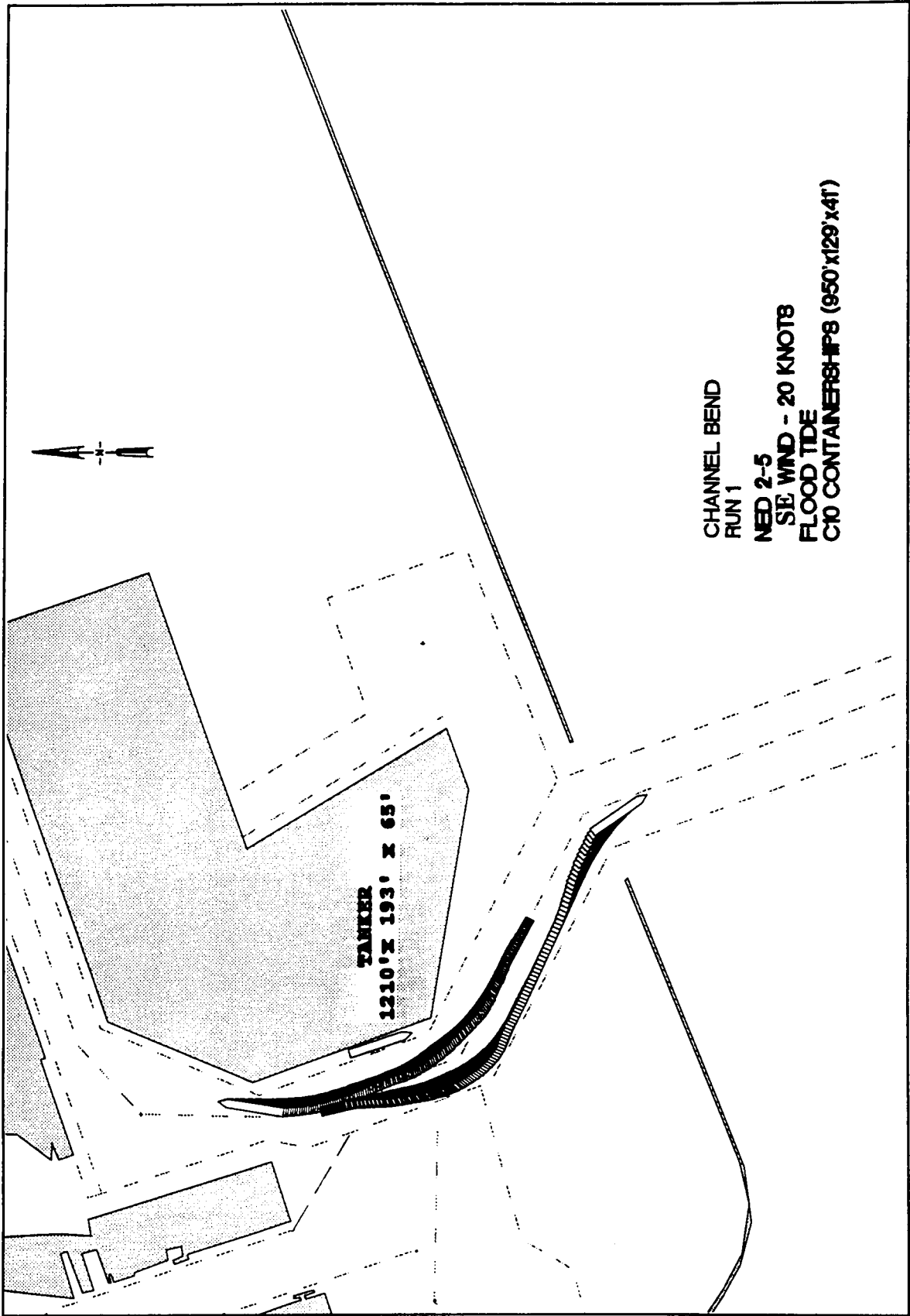
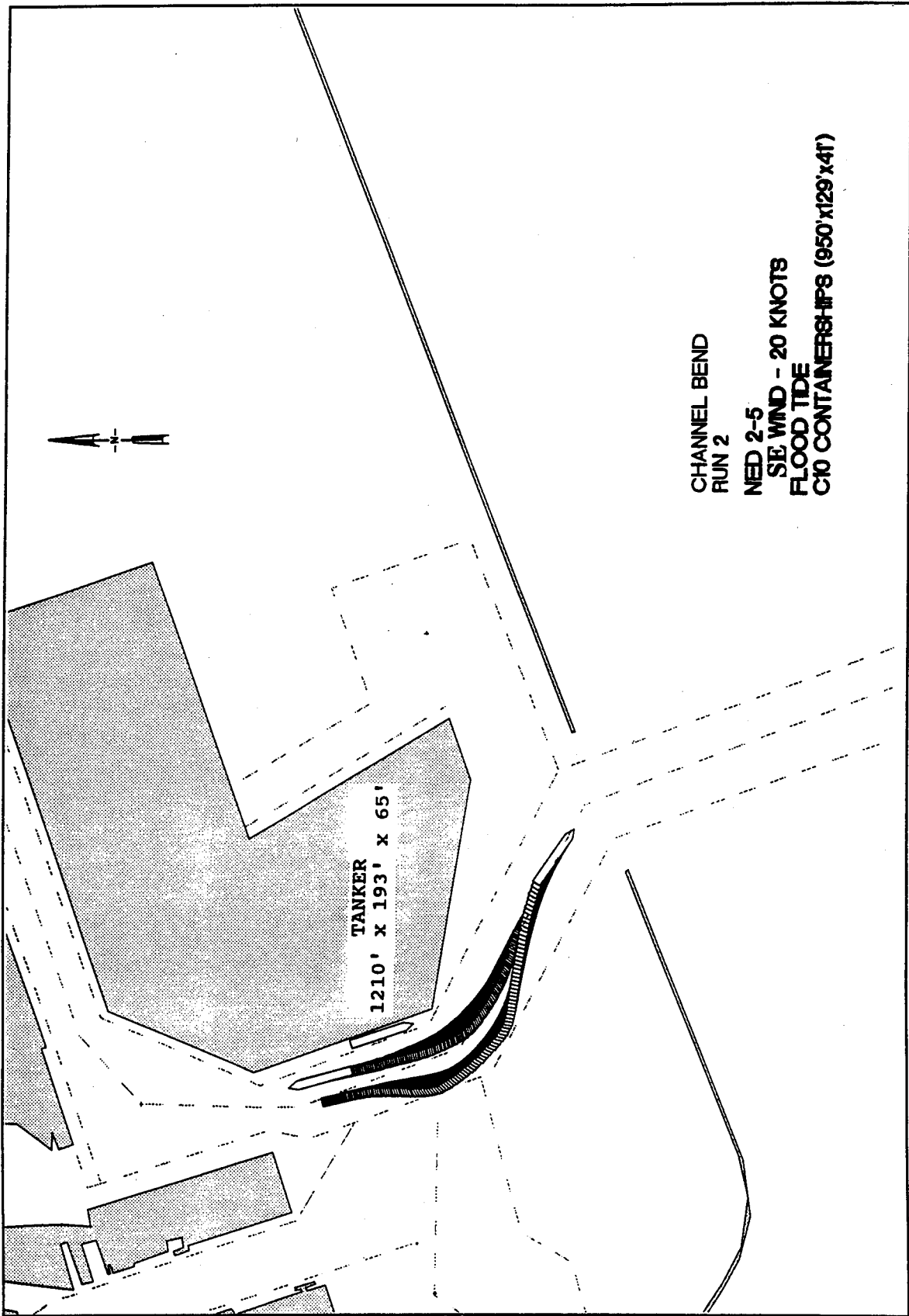

Plate 148



CHANNEL BEND  
RUN 2

NED 2-5  
SE WIND - 20 KNOTS  
FLOOD TIDE  
C/O CONTAINERSHIP (950'x129'x41')

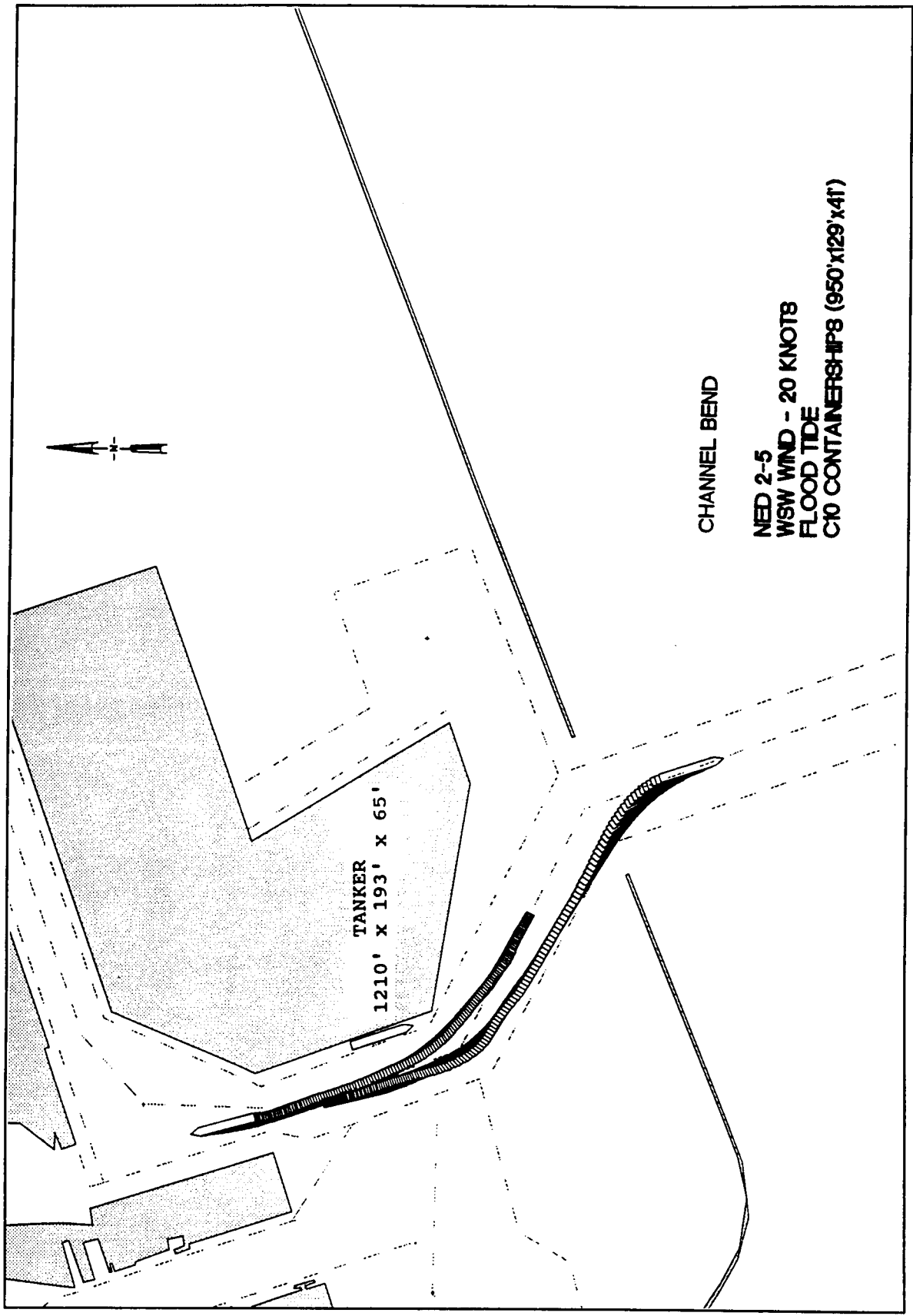
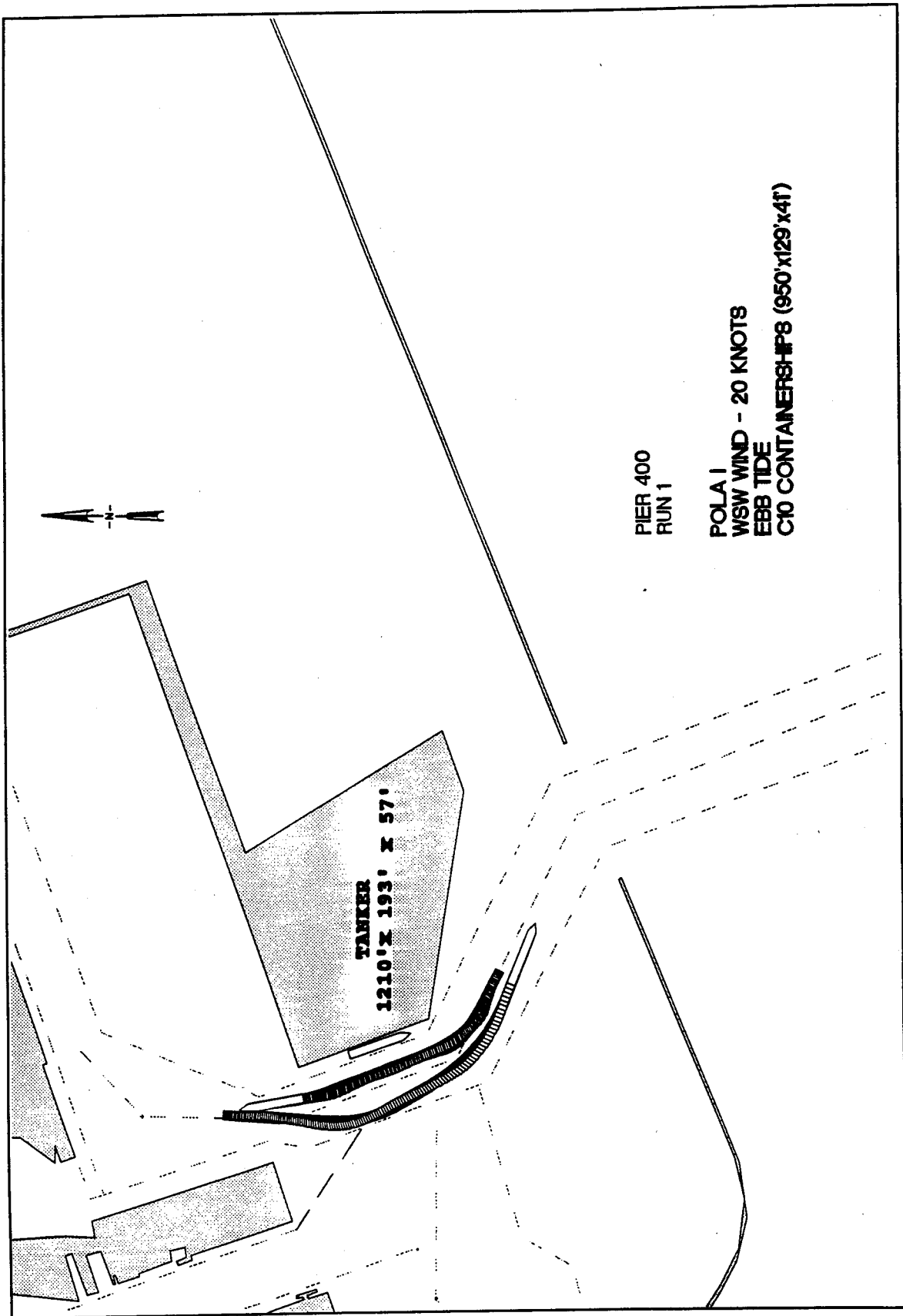

Plate 150



PIER 400  
RUN 1

POLA I  
WSW WIND - 20 KNOTS  
EBB TIDE  
C10 CONTAINERSHIPS (950'x129'x41')

TANKER  
1210' X 193' X 57'

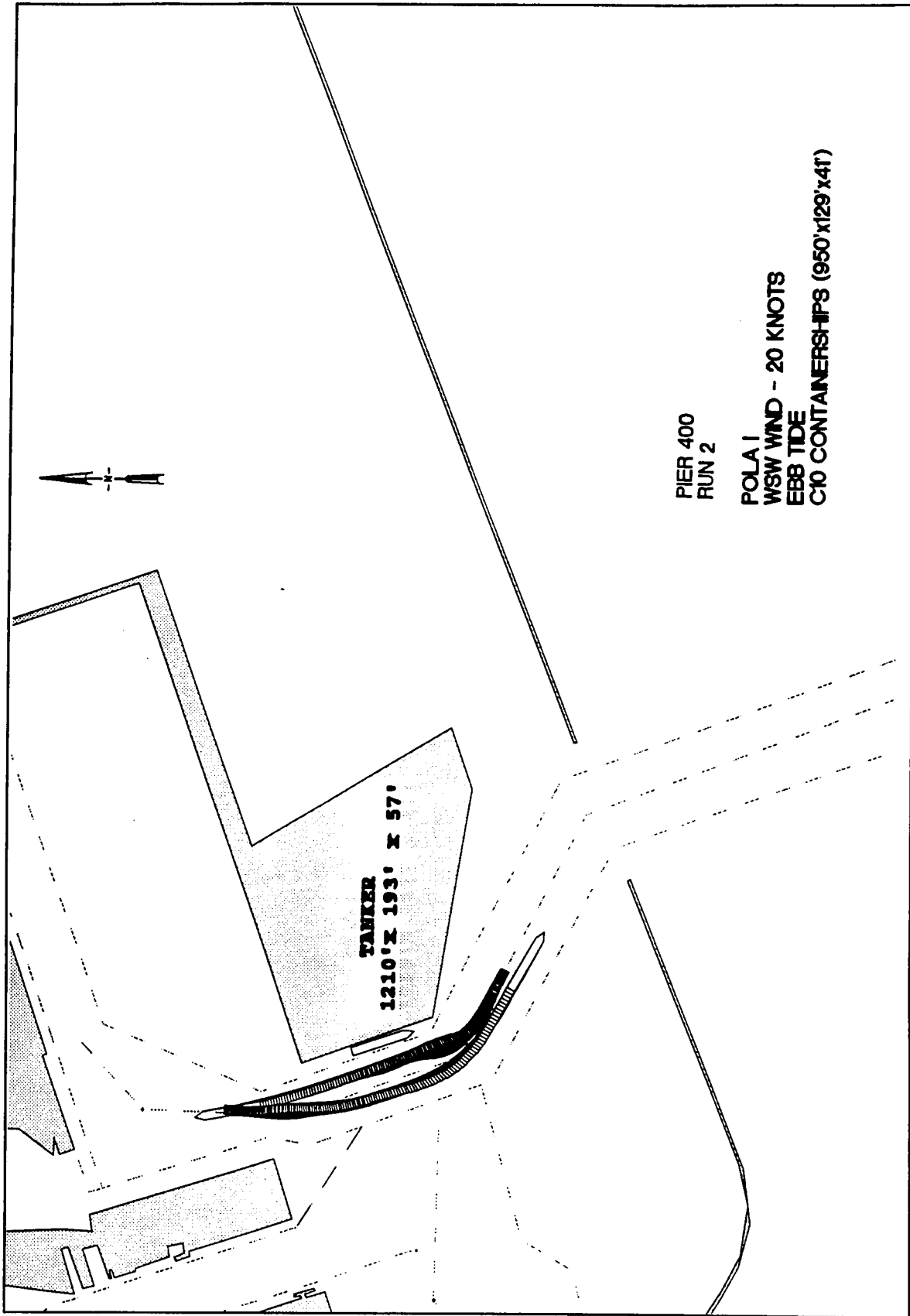

PIER 400  
RUN 2

POLA I  
WSW WIND - 20 KNOTS  
EBB TIDE  
C10 CONTAINERSHIPS (950' X 129' X 41')

TANKER  
1210' X 193' X 57'

Plate 152

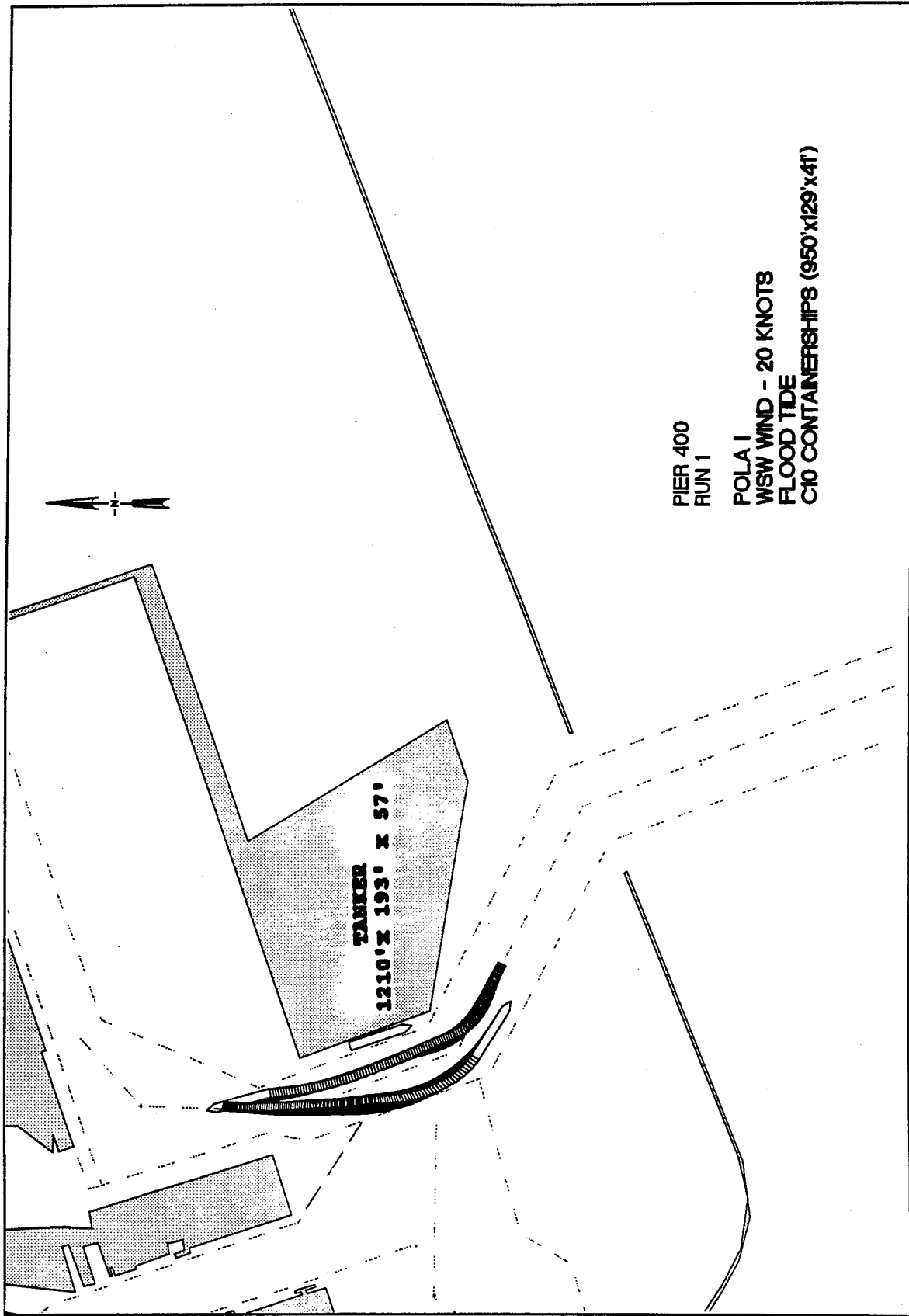

PIER 400  
RUN 1

POLA I  
WSW WIND - 20 KNOTS  
FLOOD TIDE  
C10 CONTAINERSHIPS (950'x129'x41')

TANKER  
1210'x 193' x 57'

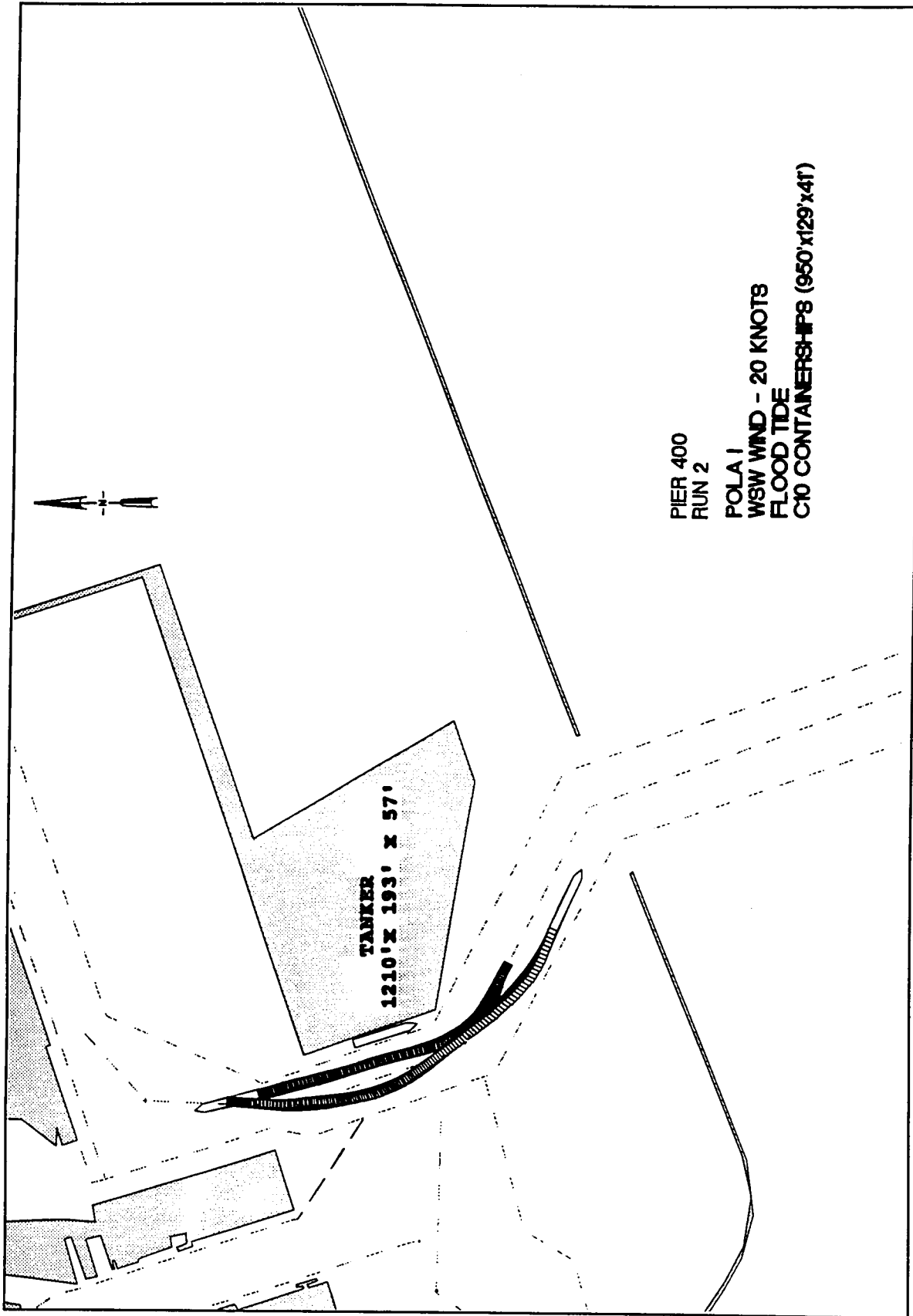

Plate 154

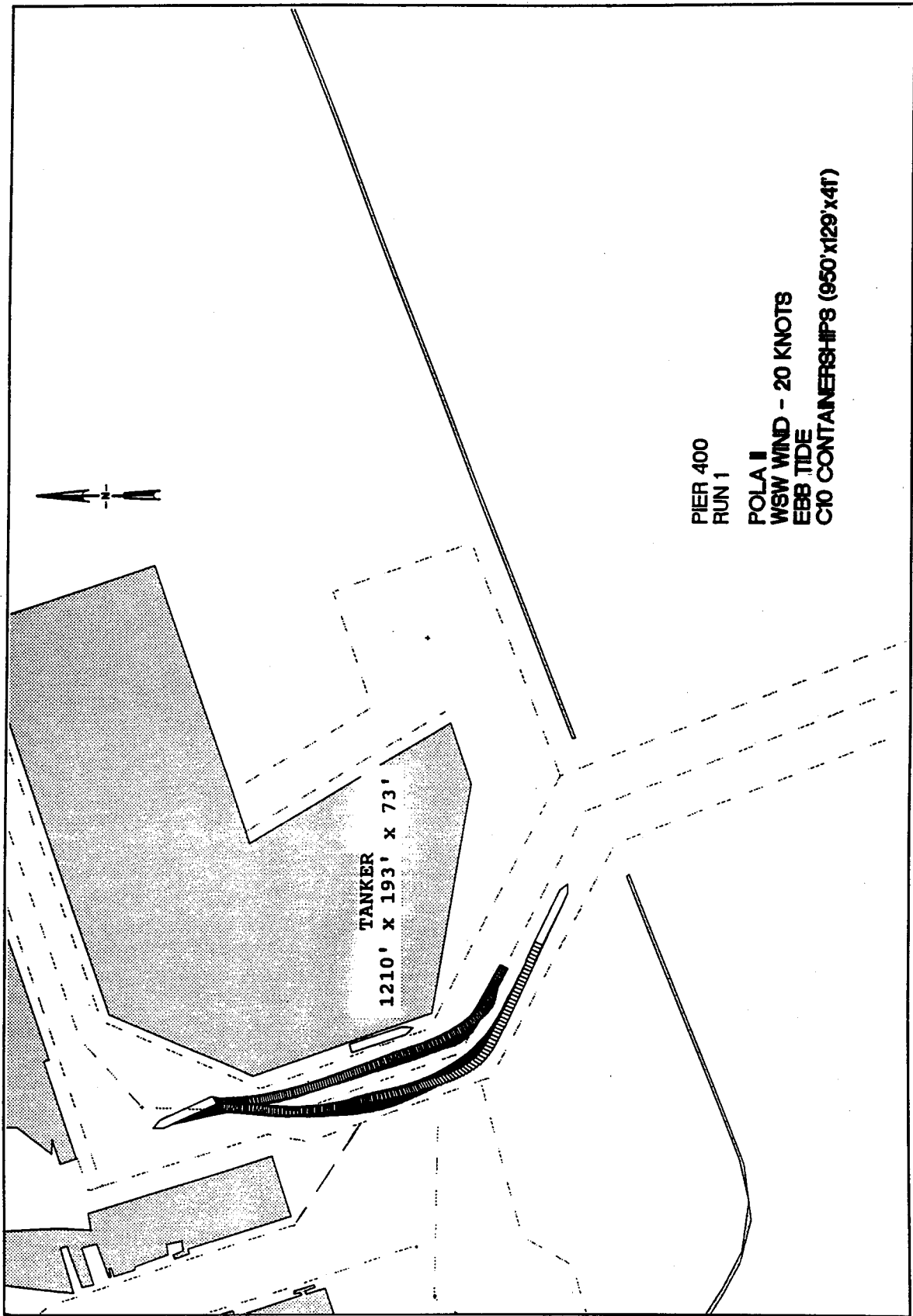

Plate 155

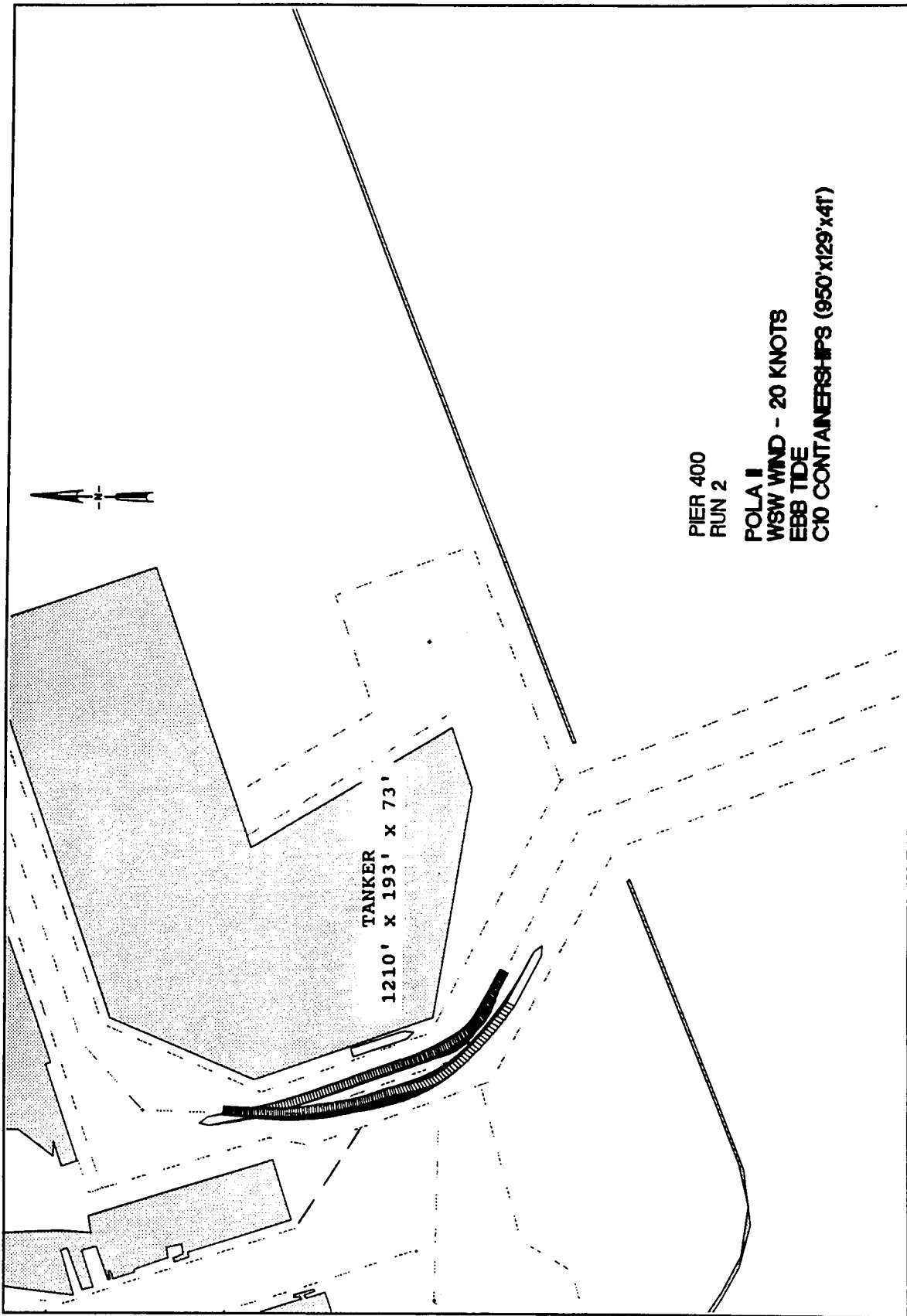
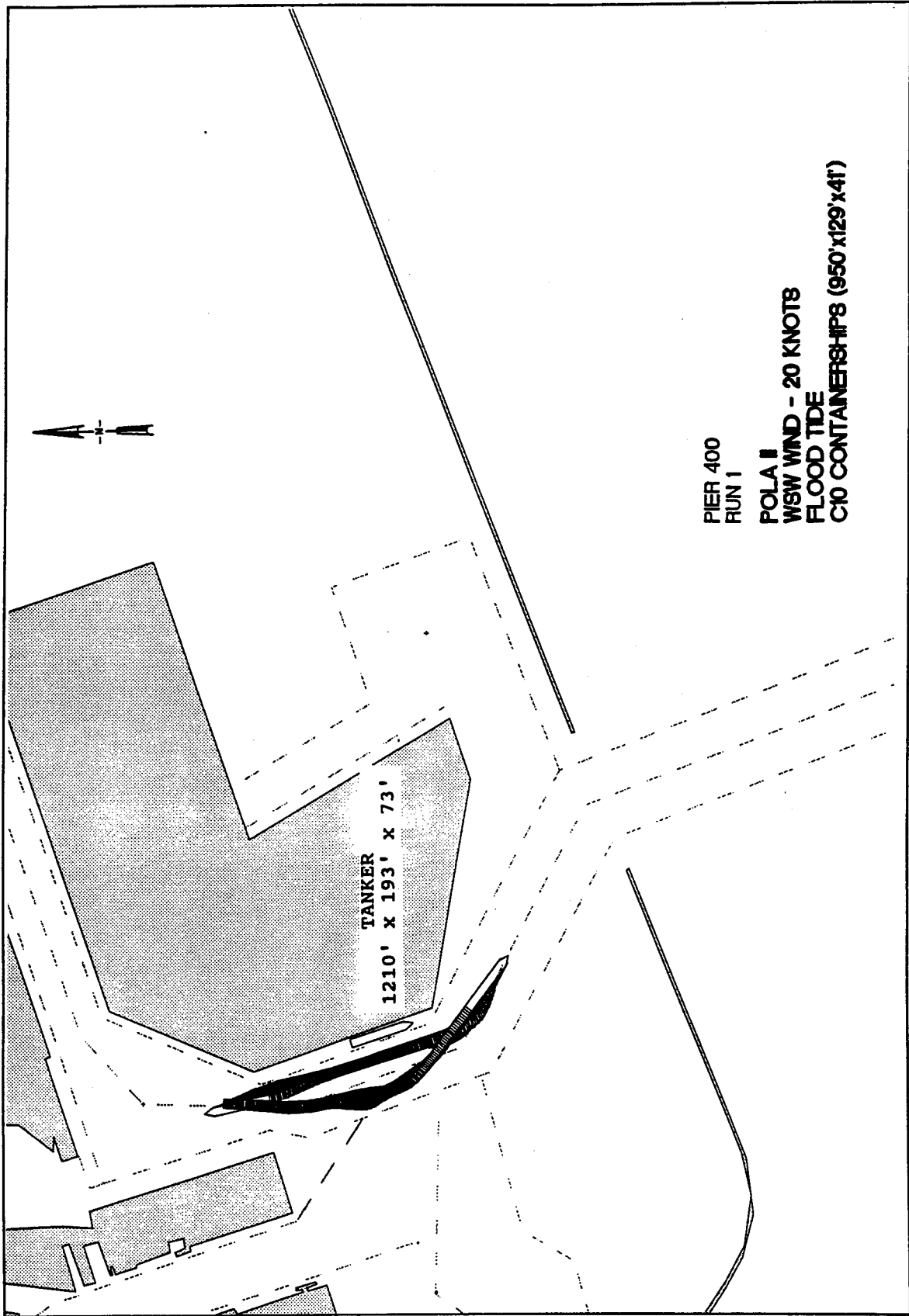

Plate 156



PIER 400  
RUN 1

POLA II  
WSW WIND - 20 KNOTS  
FLOOD TIDE  
C10 CONTAINERSHP8 (950'x129'x41')

TANKER  
1210' x 193' x 73'

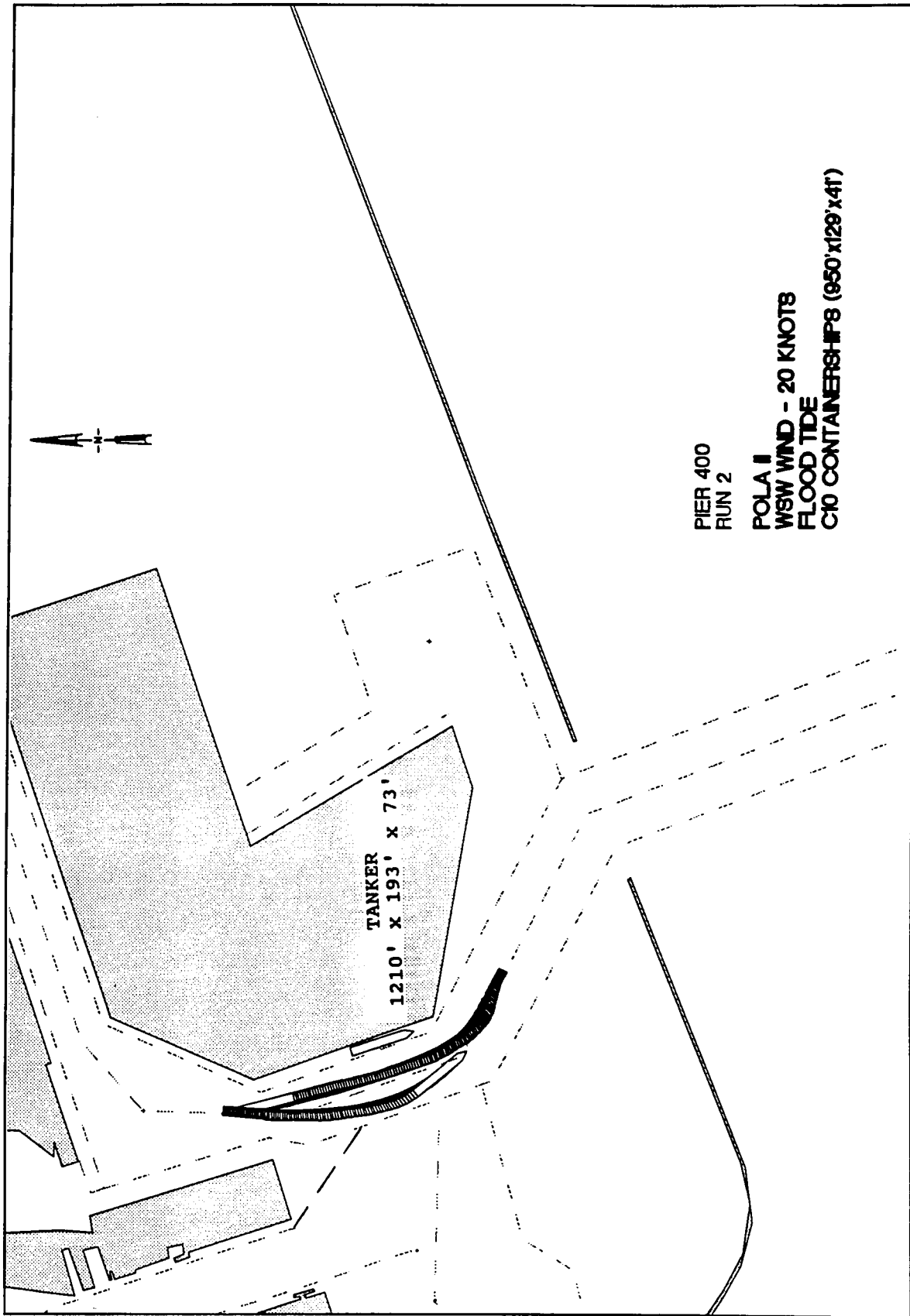
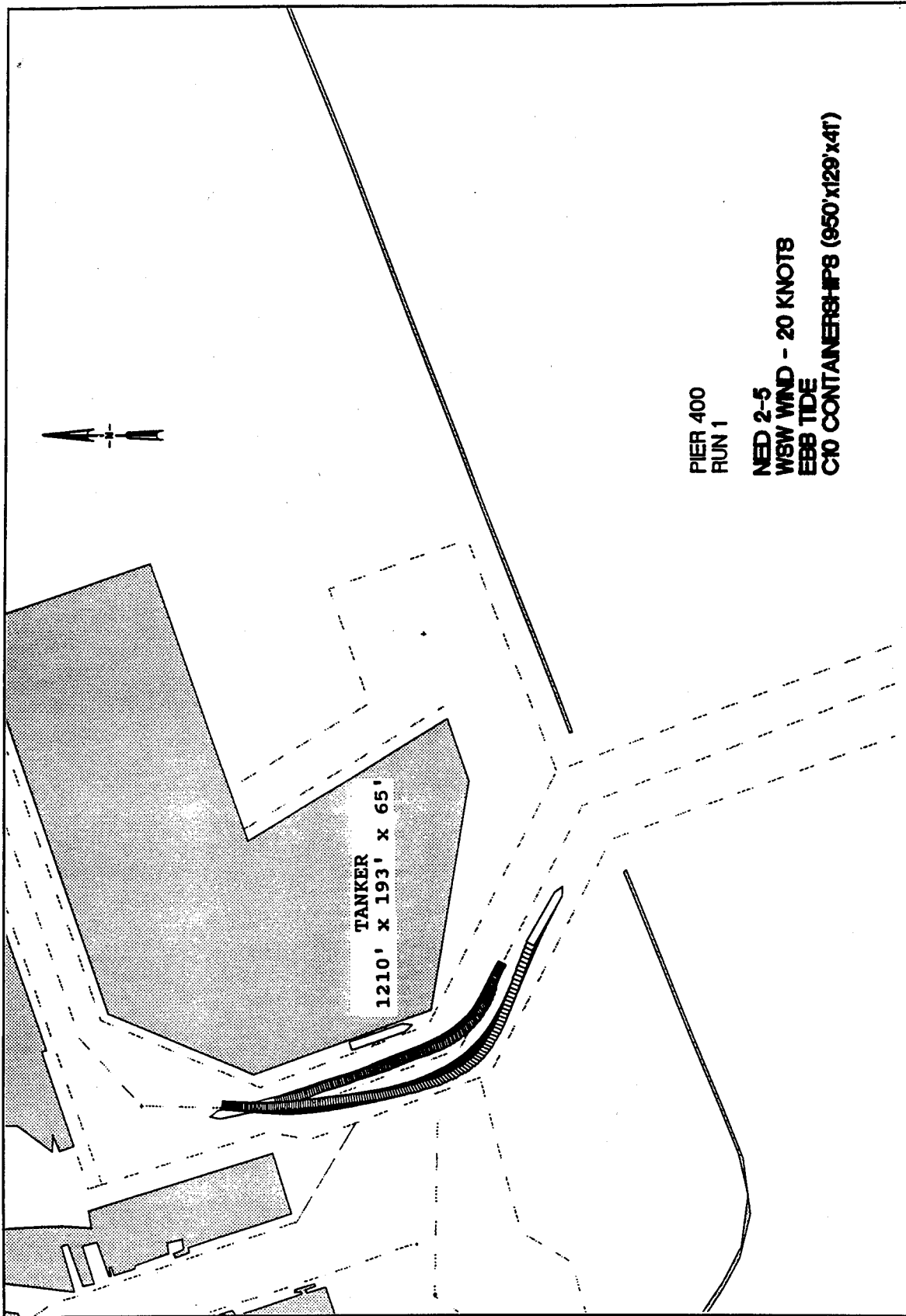

Plate 158



PIER 400  
RUN 1

NED 2-5  
WSW WIND - 20 KNOTS  
EBB TIDE  
C10 CONTAINERSHIP8 (950'x129'x41')

TANKER  
1210' x 193' x 65'

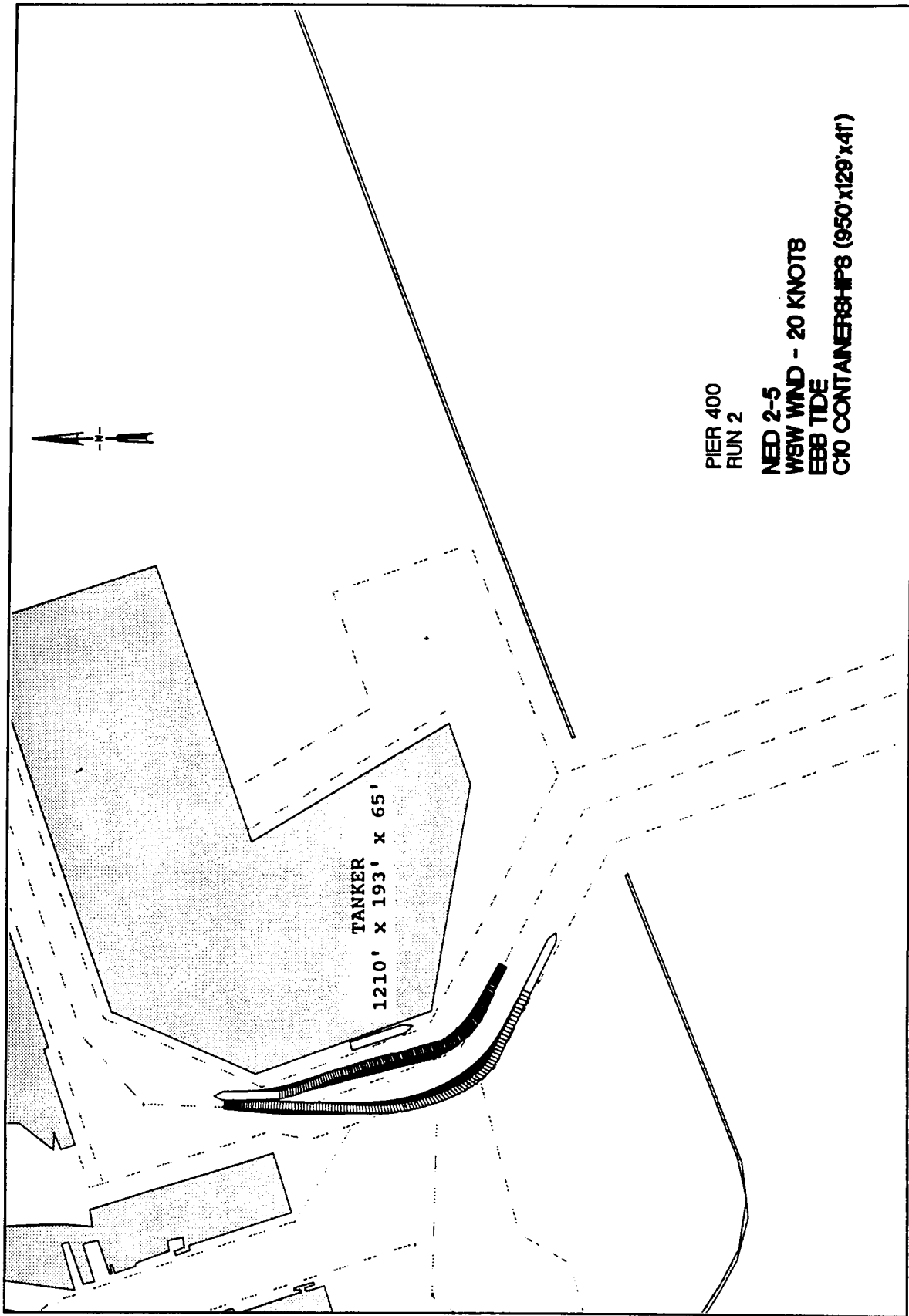

PIER 400  
RUN 2

NED 2-5  
WSW WIND - 20 KNOTS  
EBB TIDE  
C10 CONTAINERSHP8 (950'x129'x41')

TANKER  
1210' x 193' x 65'

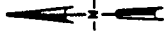
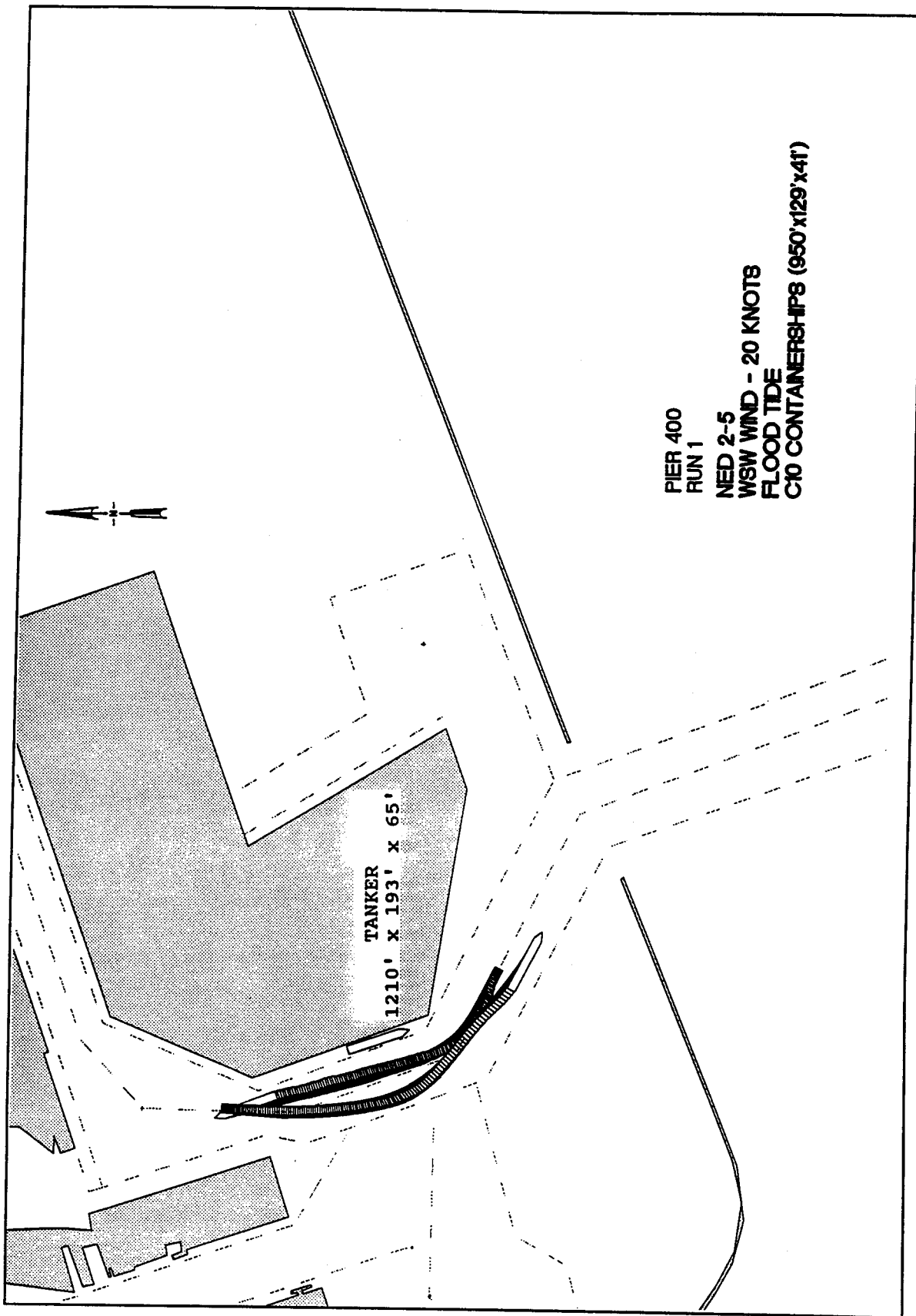

Plate 160



PIER 400  
RUN 1  
NED 2-5  
WSW WIND - 20 KNOTS  
FLOOD TIDE  
C10 CONTAINERSHIP8 (950'x129'x41')

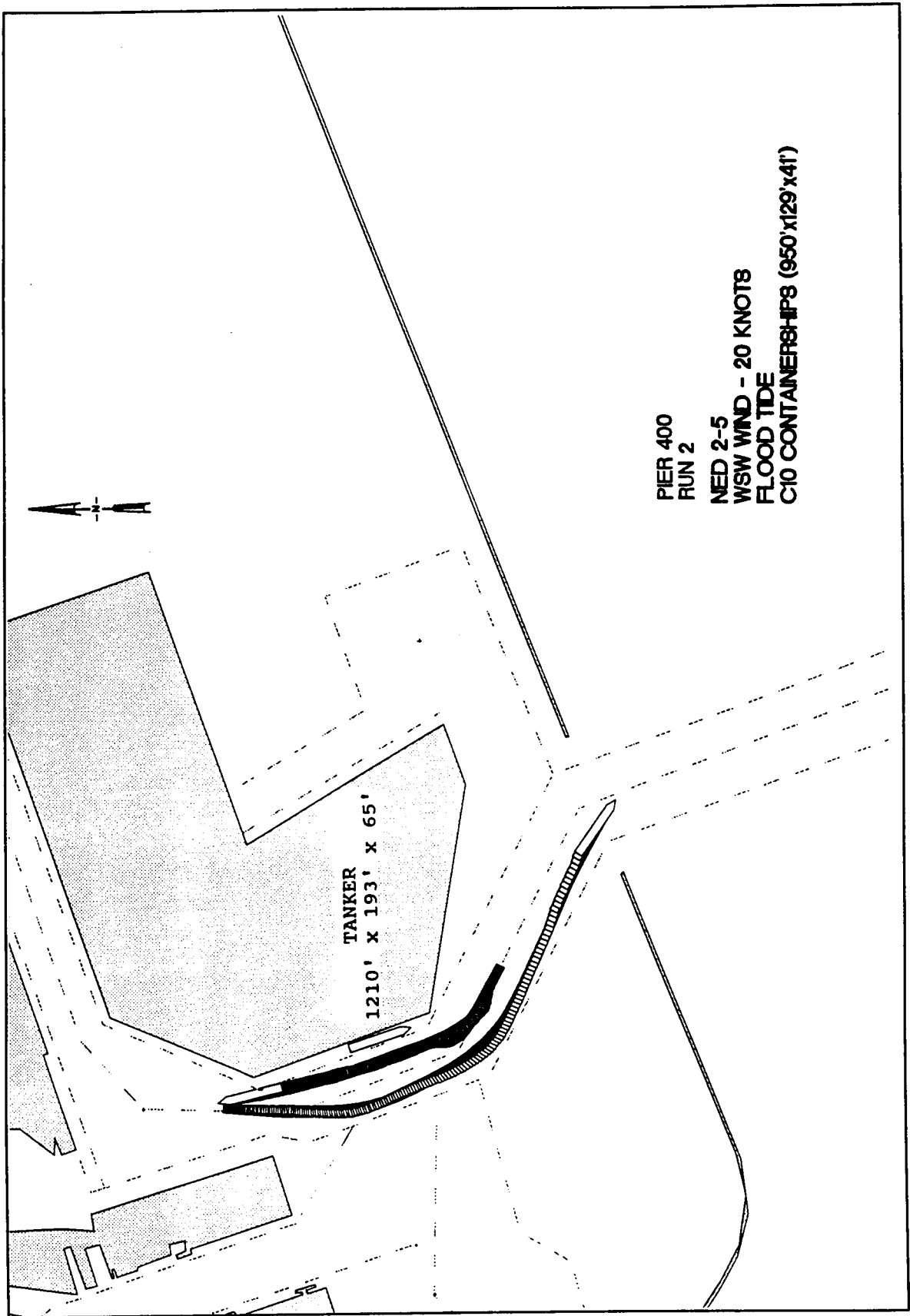
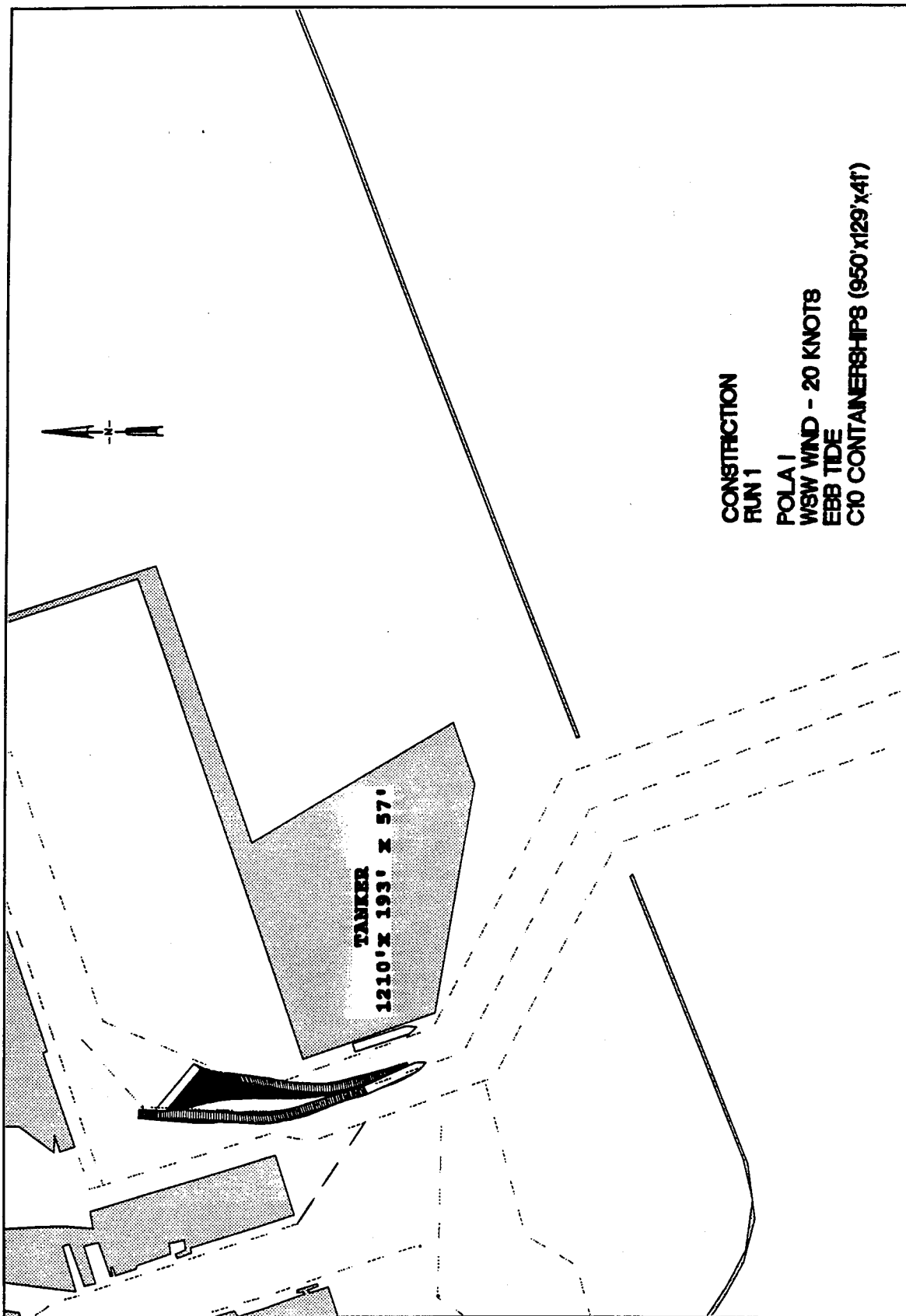

Plate 162



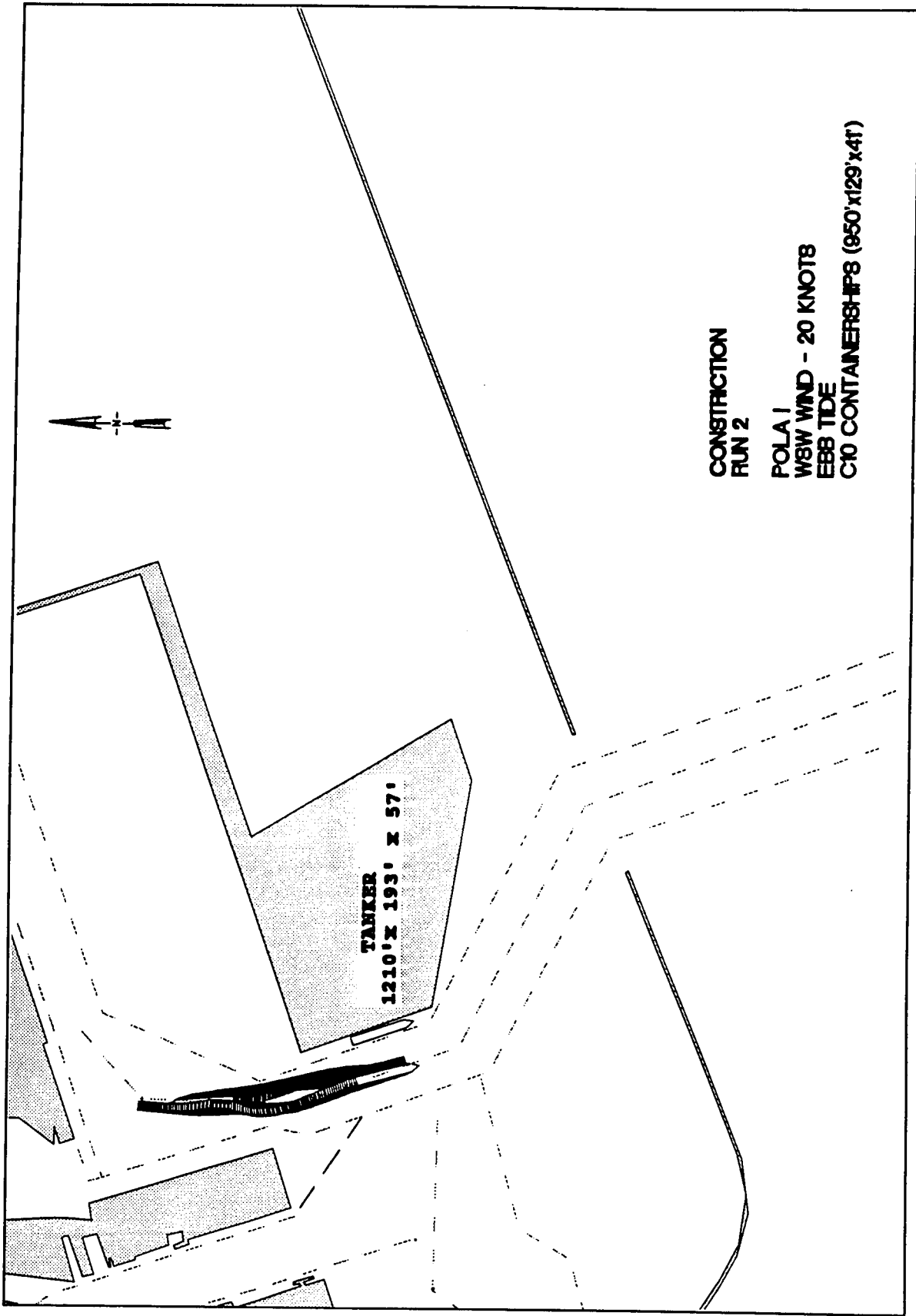
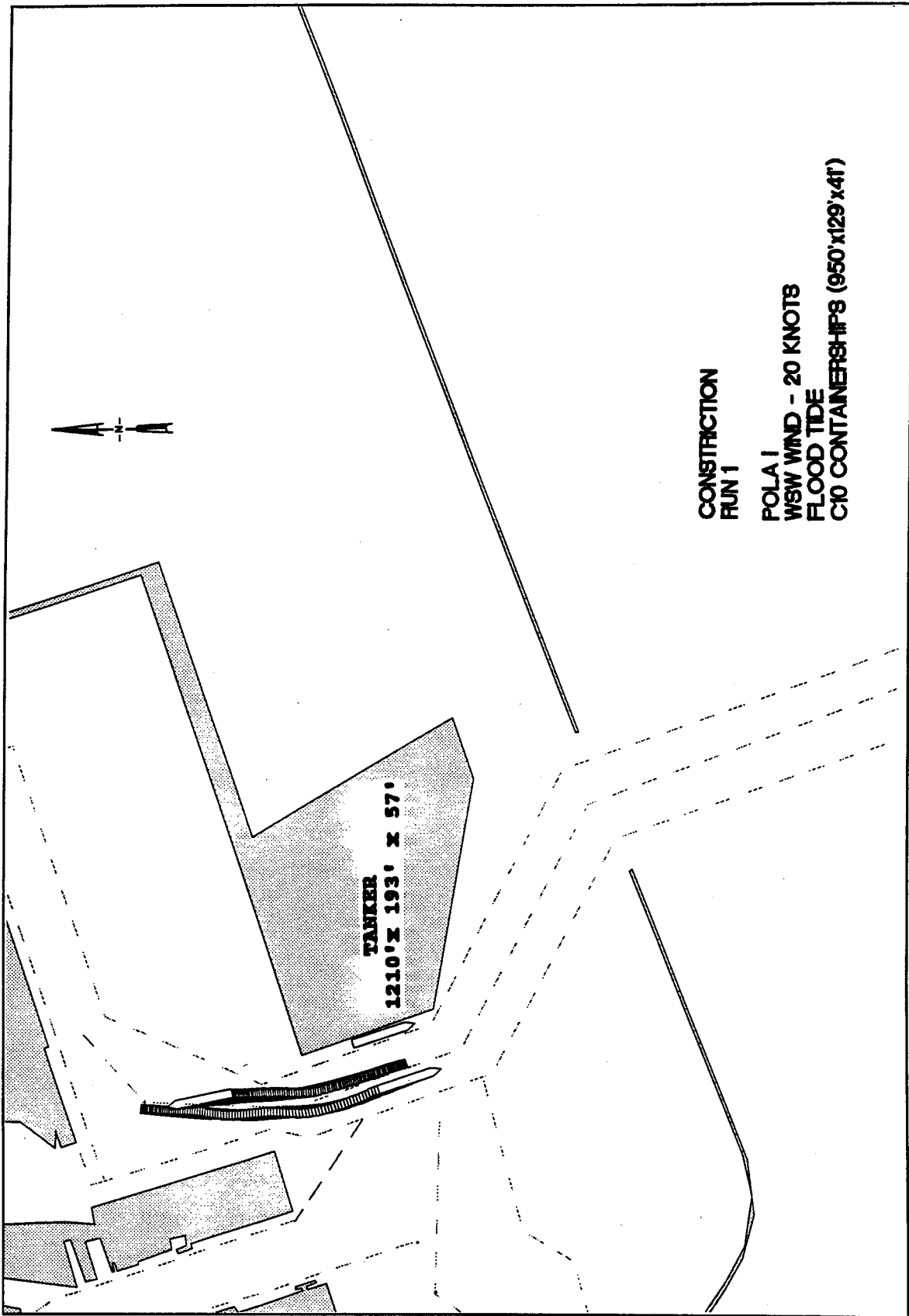

Plate 164



CONSTRUCTION  
RUN 1

POLA I  
WSW WIND - 20 KNOTS  
FLOOD TIDE  
C10 CONTAINERSHP8 (950'x129'x41')

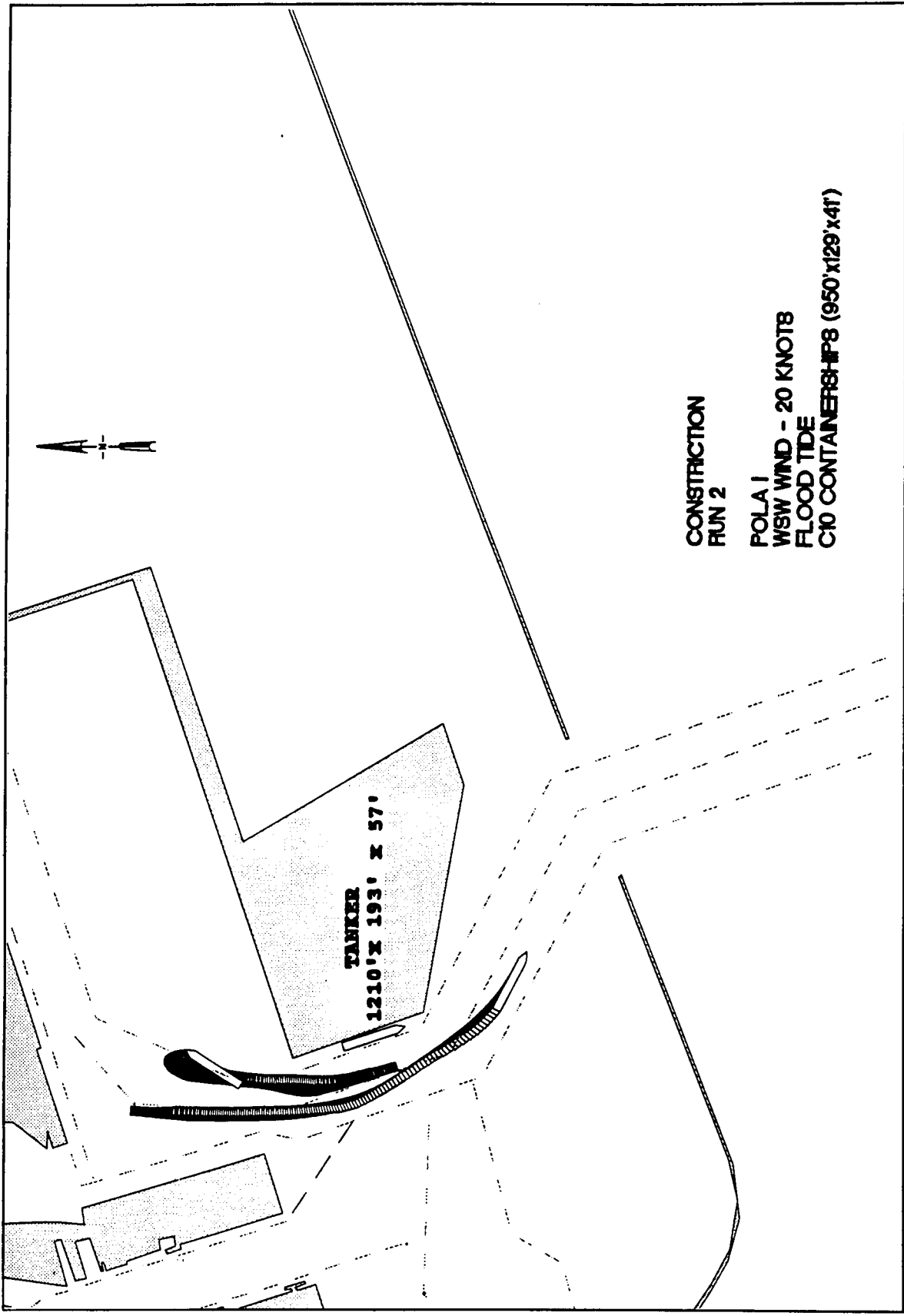

Plate 166

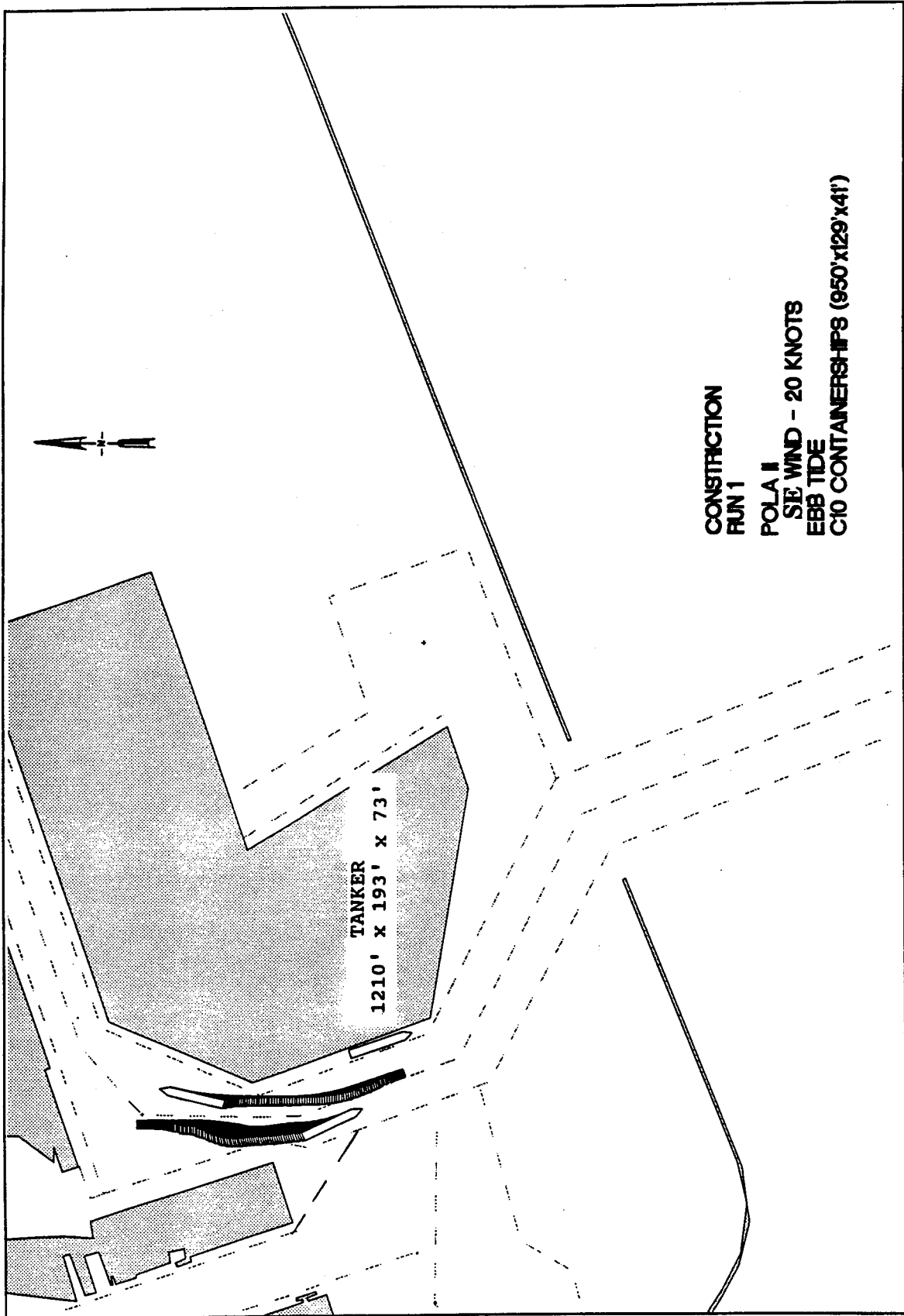
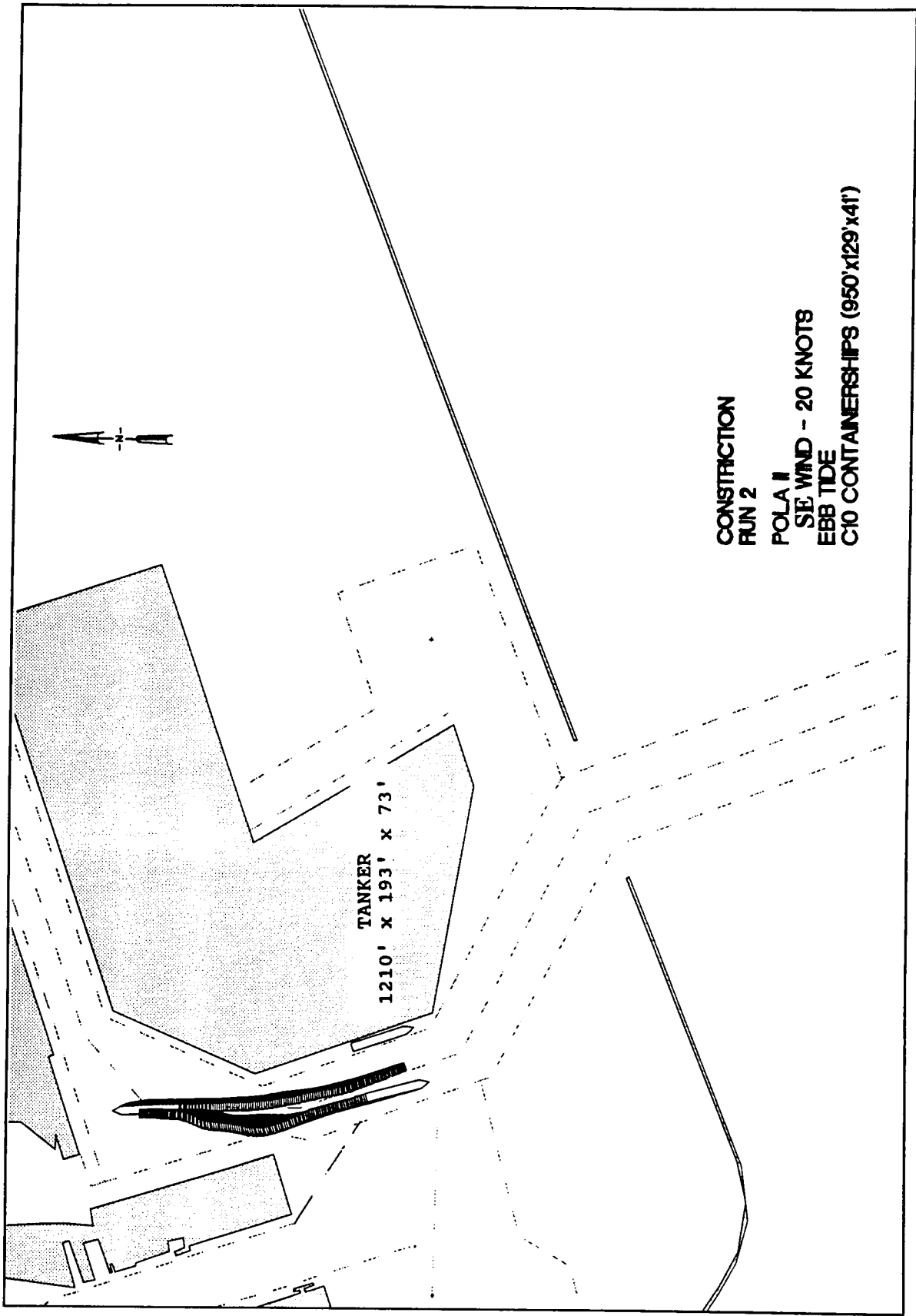

Plate 167



CONSTRUCTION  
FUN 2

POLA II  
SE WIND - 20 KNOTS  
EBB TIDE  
C10 CONTAINERSHIPS (950'x129'x41')

Plate 168

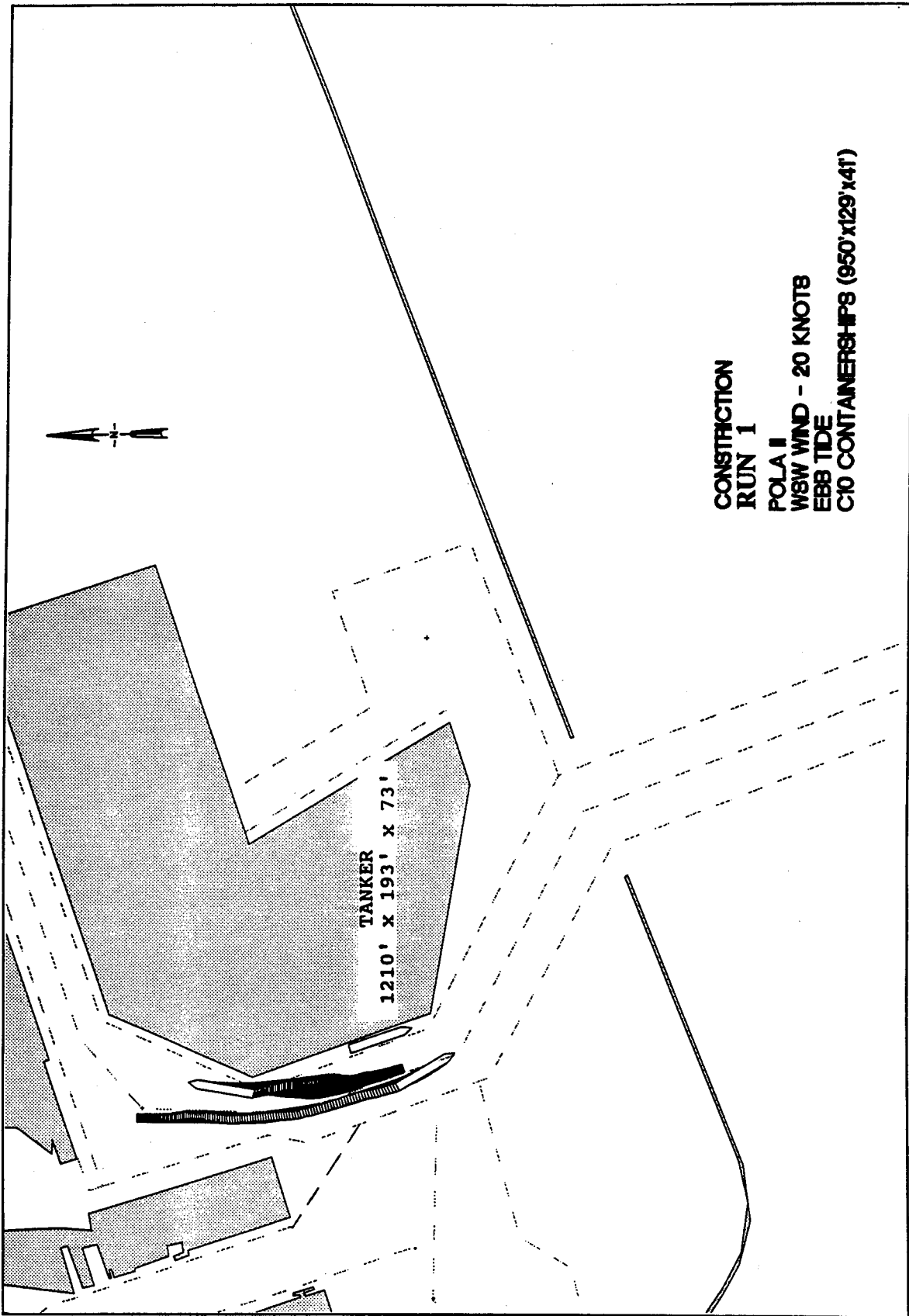

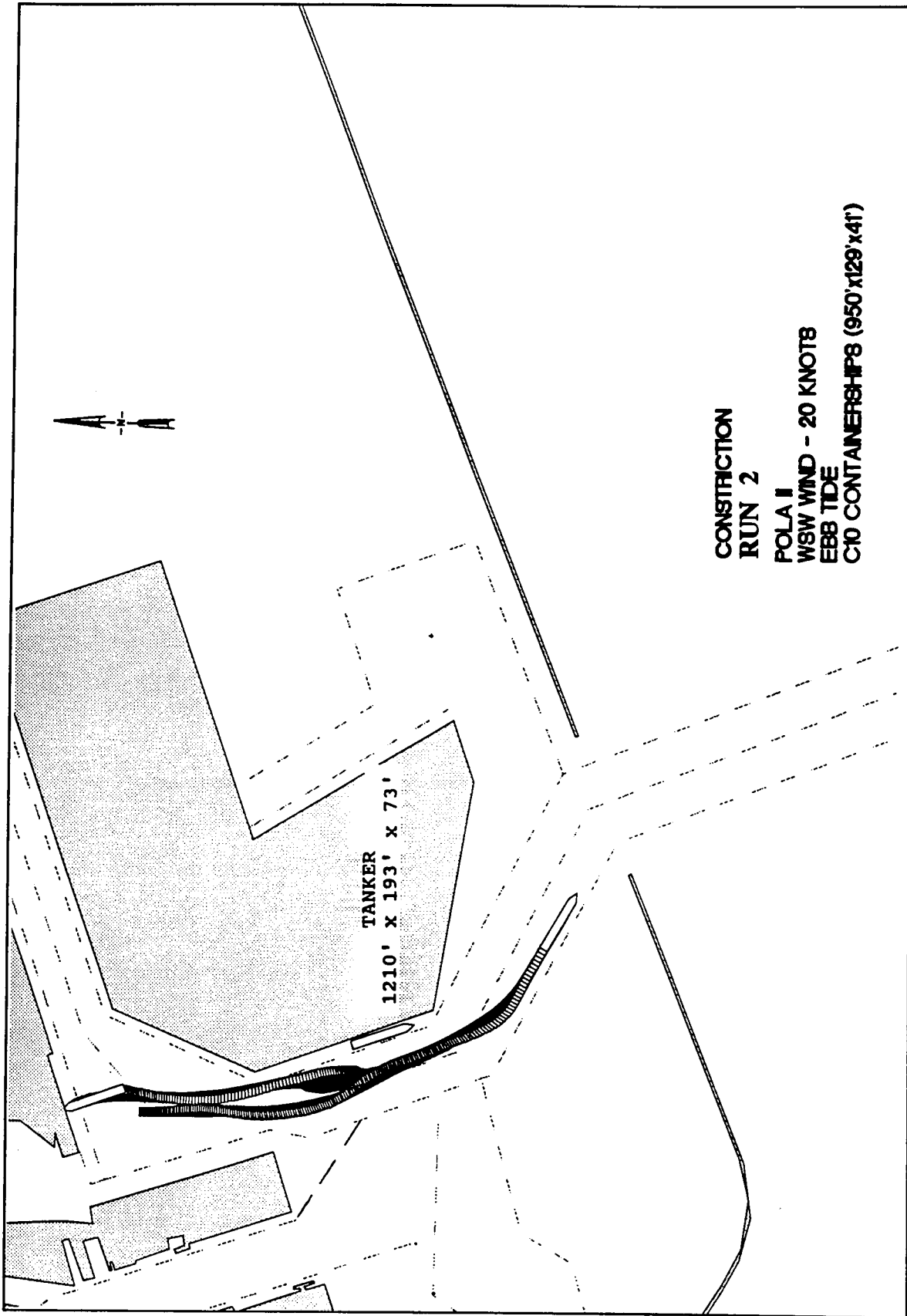

Plate 170

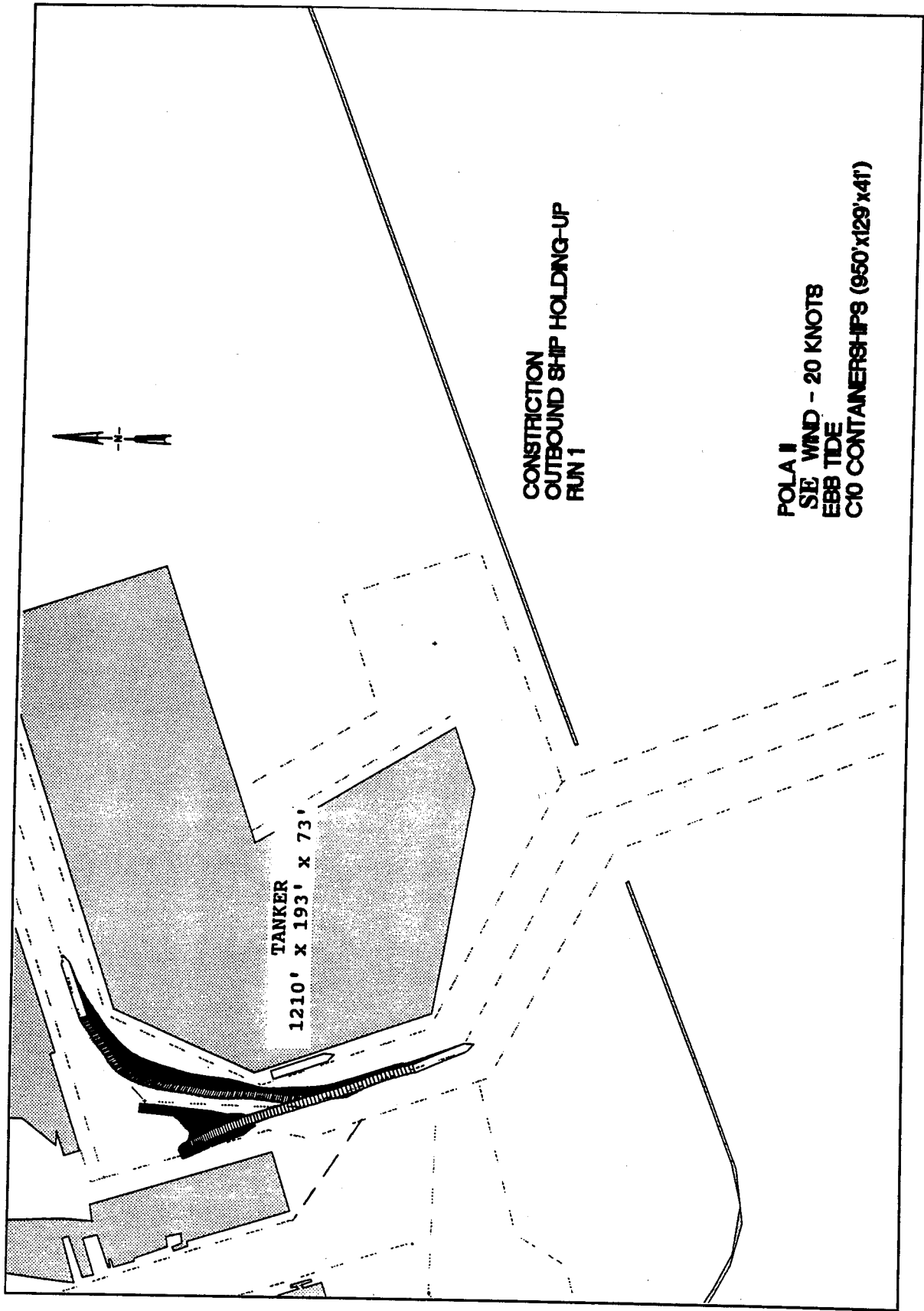
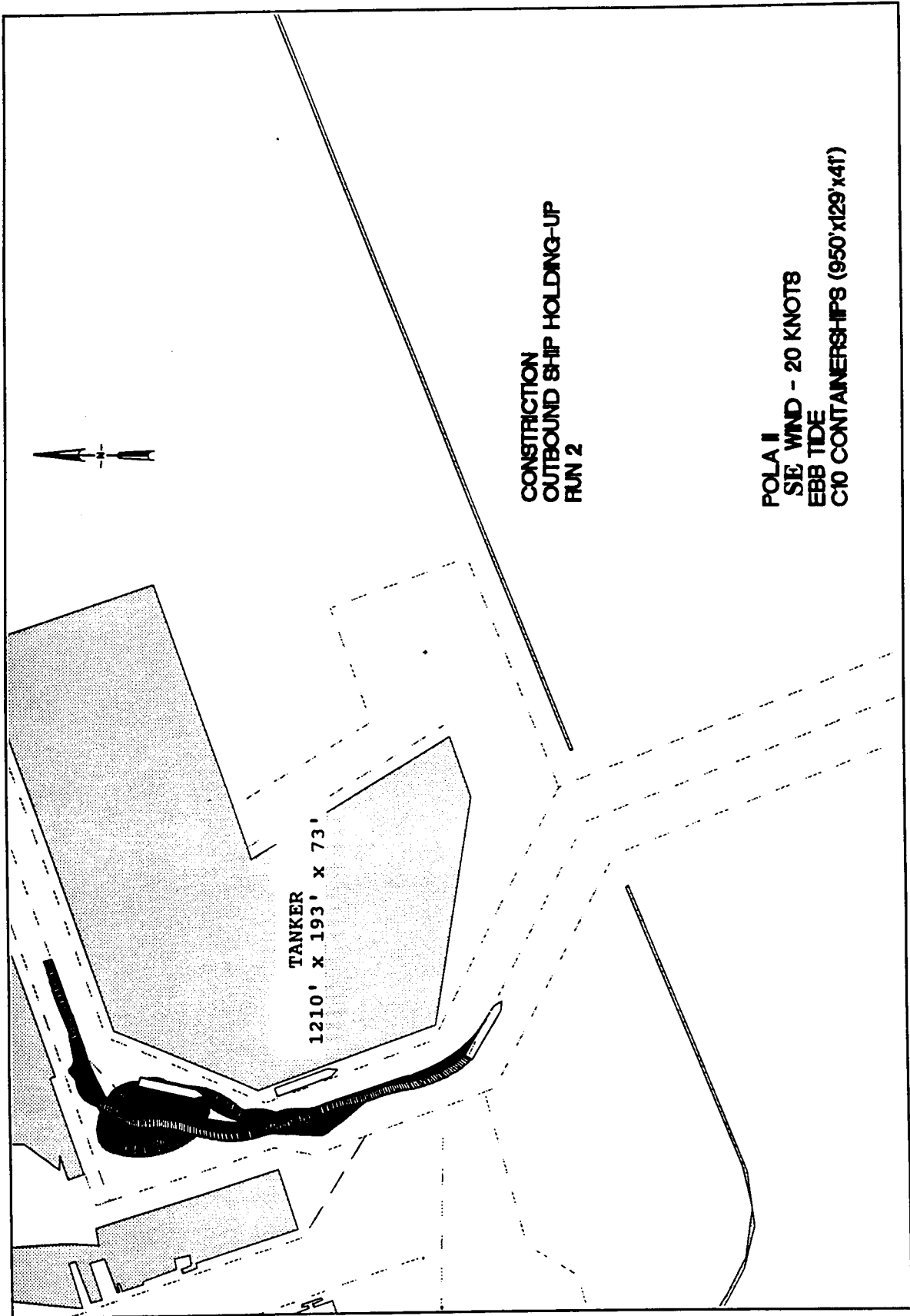

Plate 171



CONSTRUCTION  
OUTBOUND SHIP HOLDING-UP  
RUN 2

TANKER  
1210' x 193' x 73'

POLA II  
SE WIND - 20 KNOTS  
EBB TIDE  
C10 CONTAINERSHIPS (950'x129'x41')

Plate 172

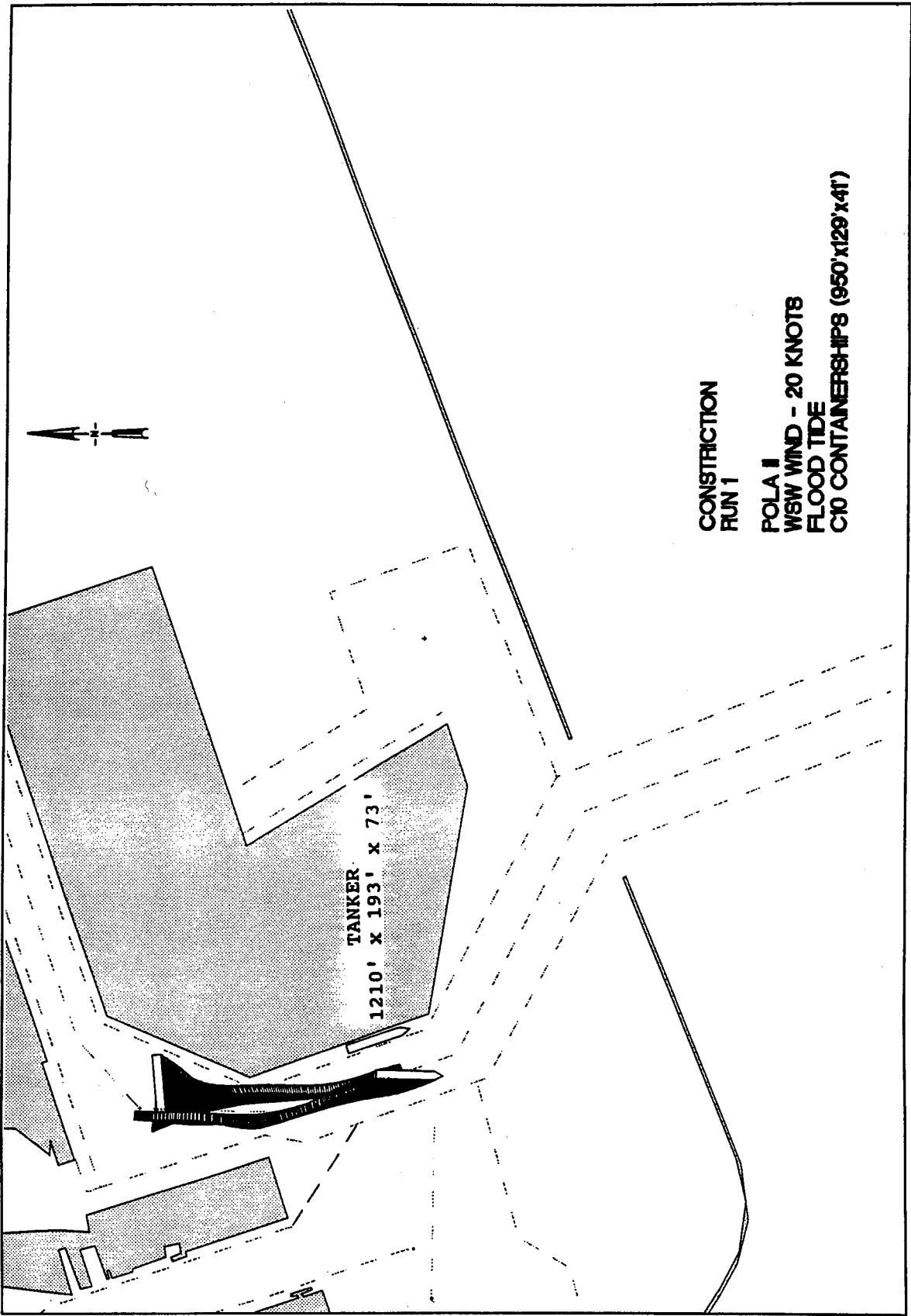

CONSTRUCTION  
RUN 1

POLA II  
WSW WIND - 20 KNOTS  
FLOOD TIDE  
C10 CONTAINERSHIPS (950'x129'x41')

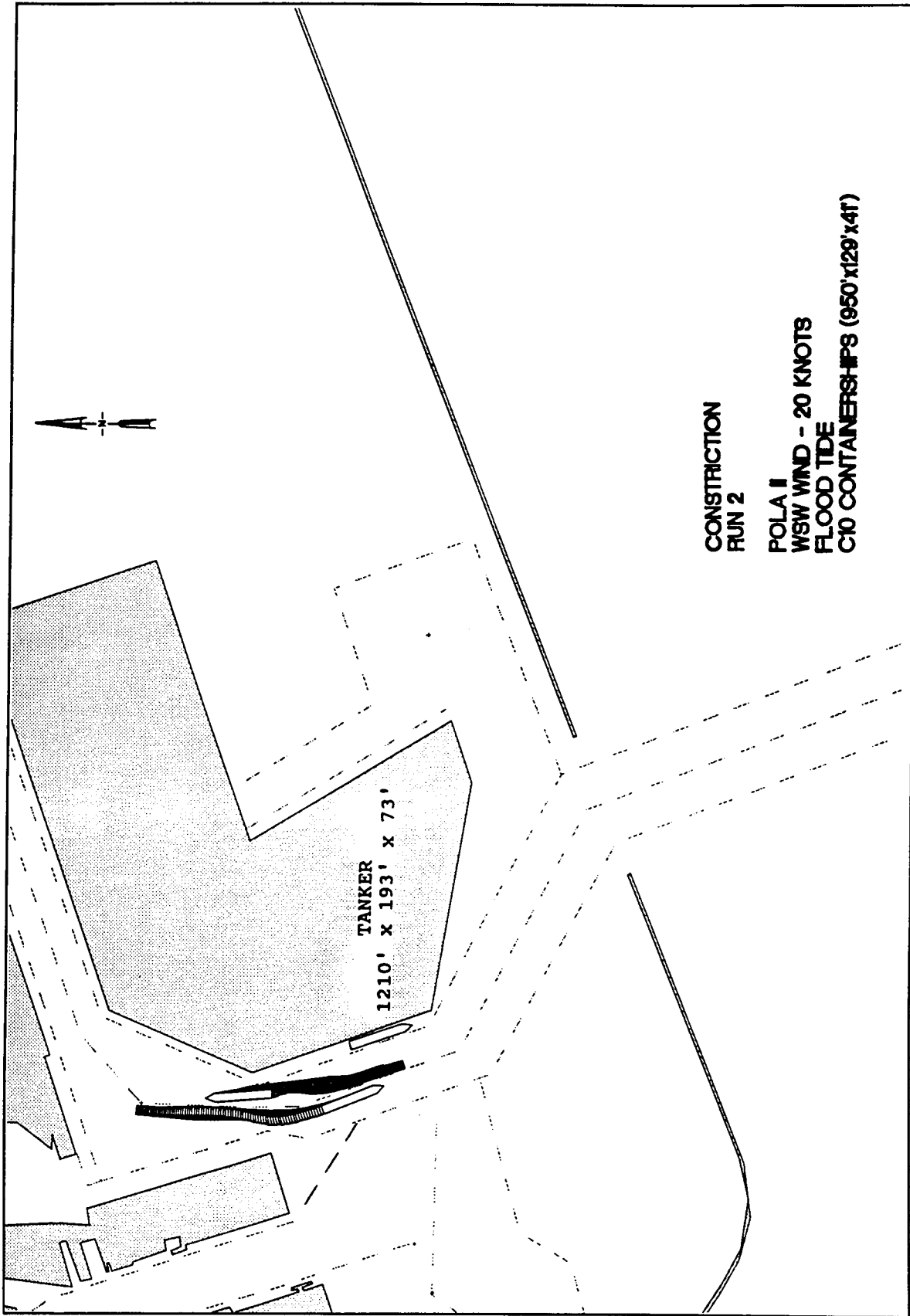

Plate 174

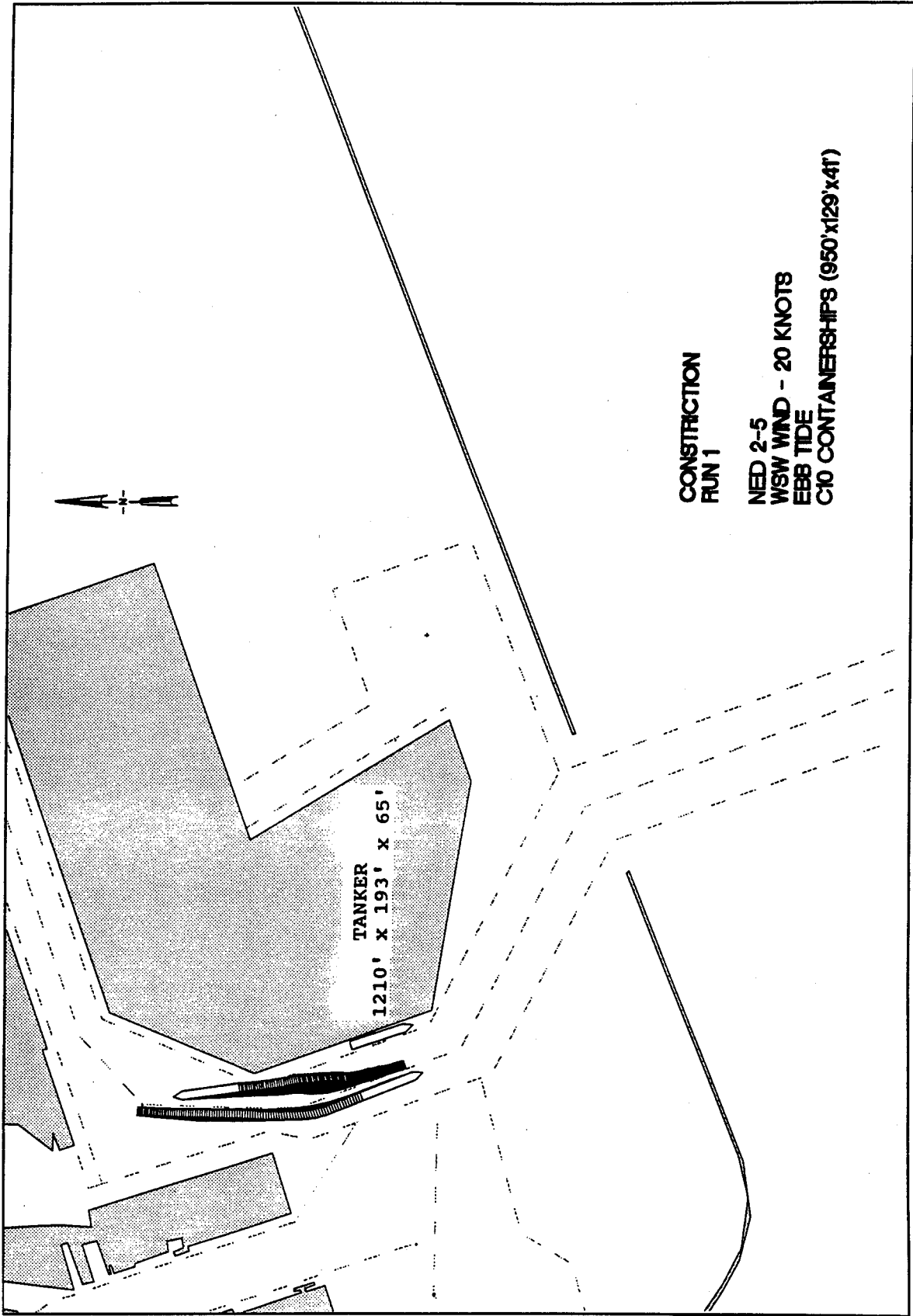

Plate 175

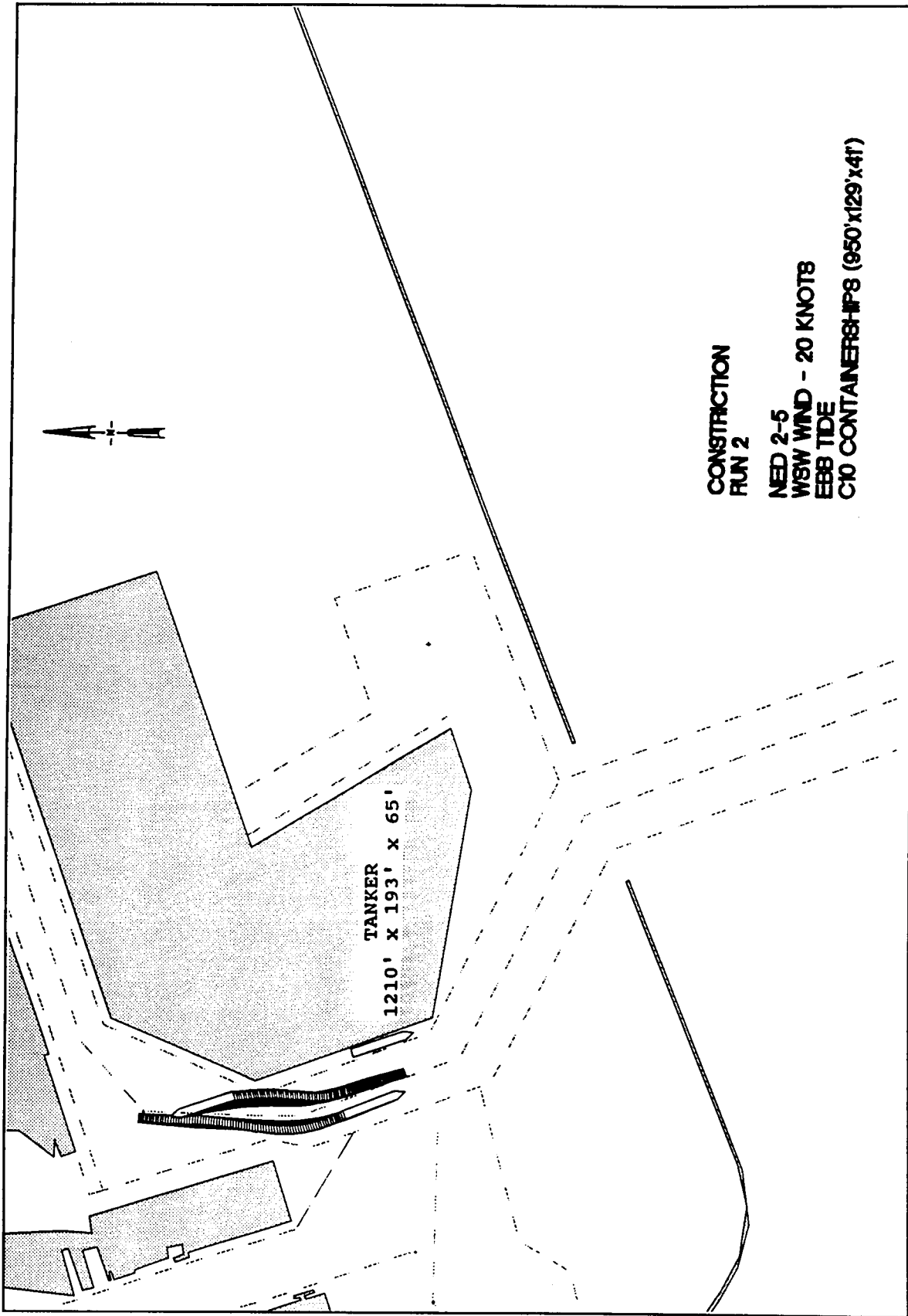
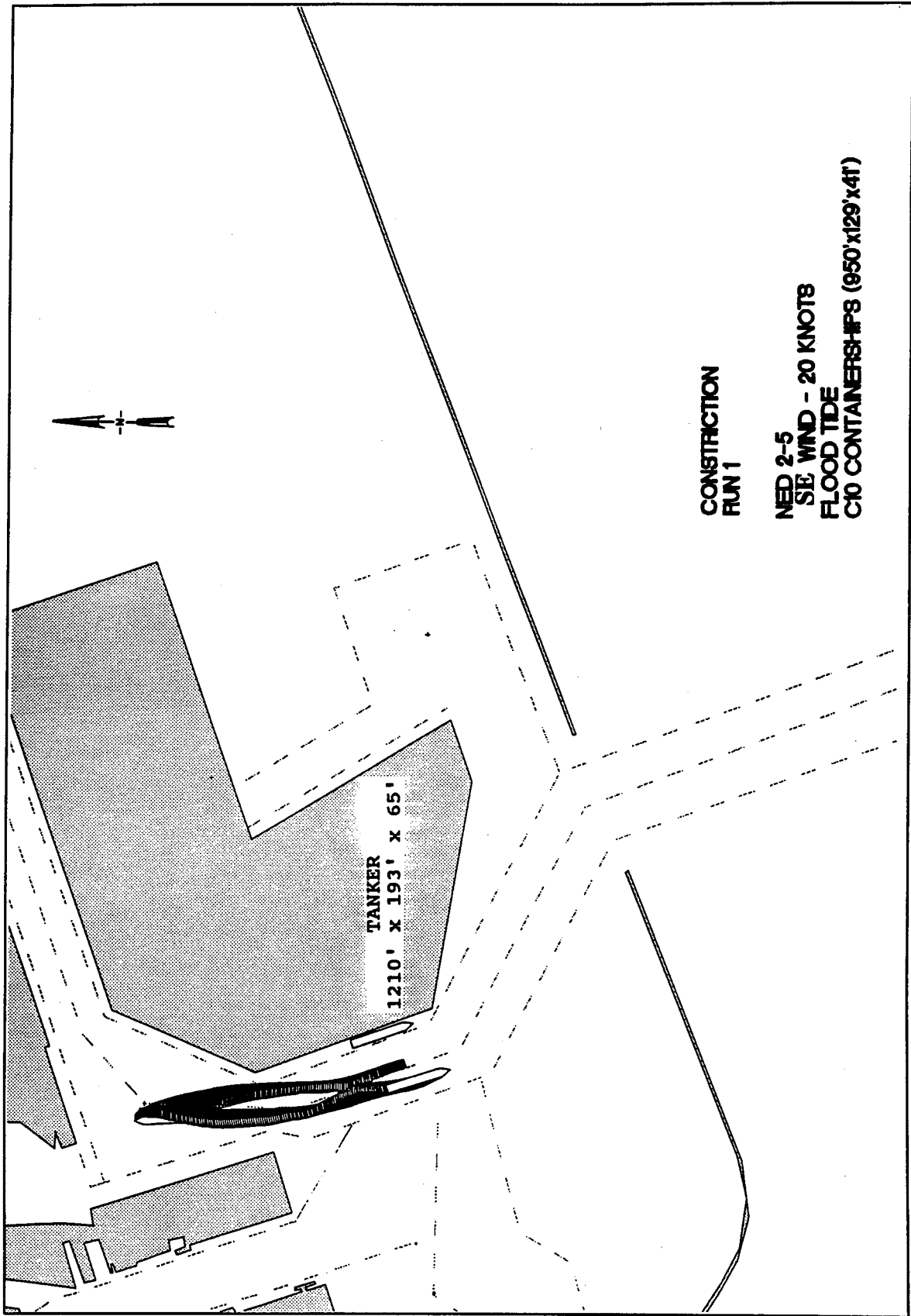

Plate 176



CONSTRUCTION  
RUN 1

NED 2-5  
SE WIND - 20 KNOTS  
FLOOD TIDE  
C10 CONTAINERSHIPS (950'x129'x41')

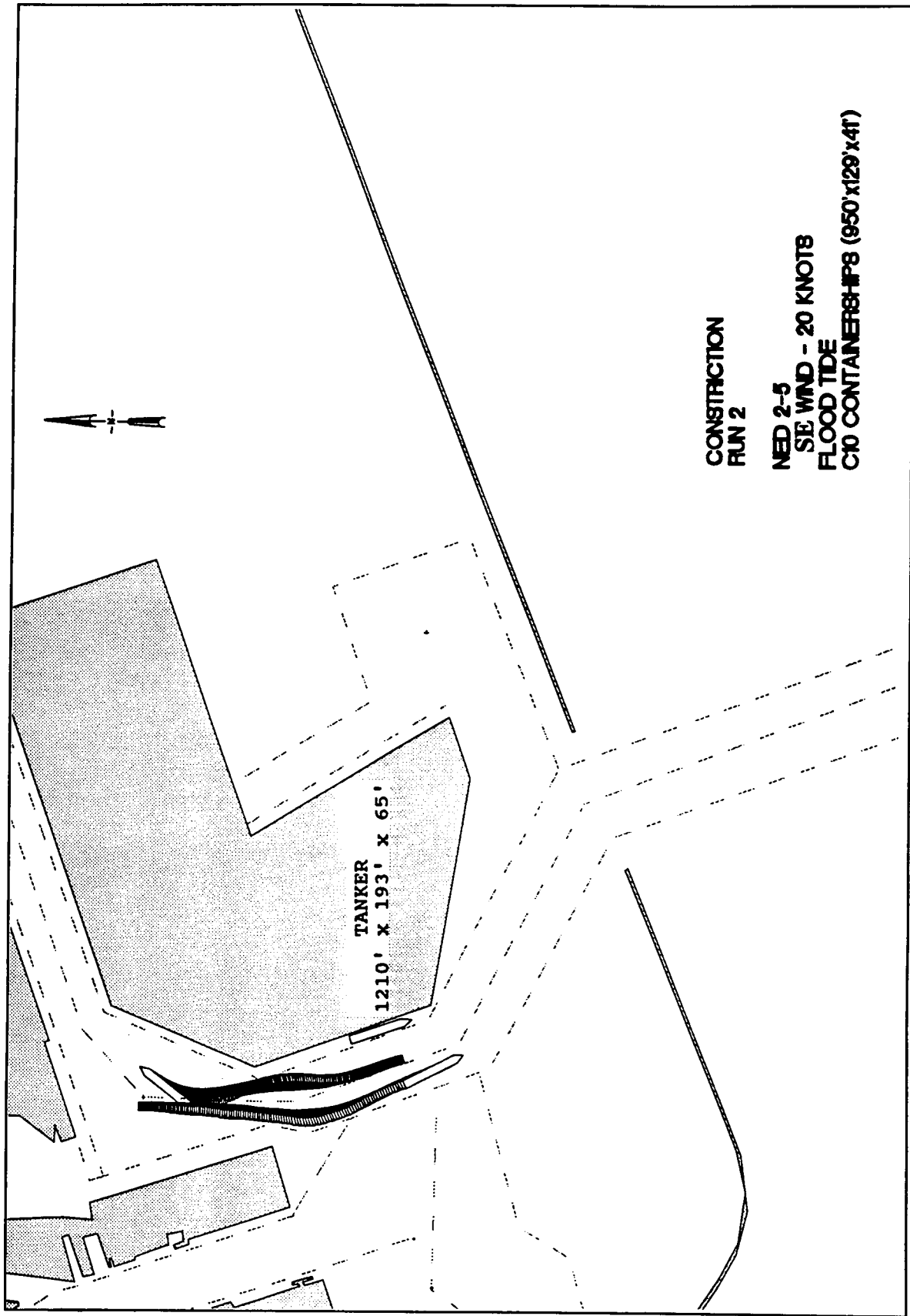
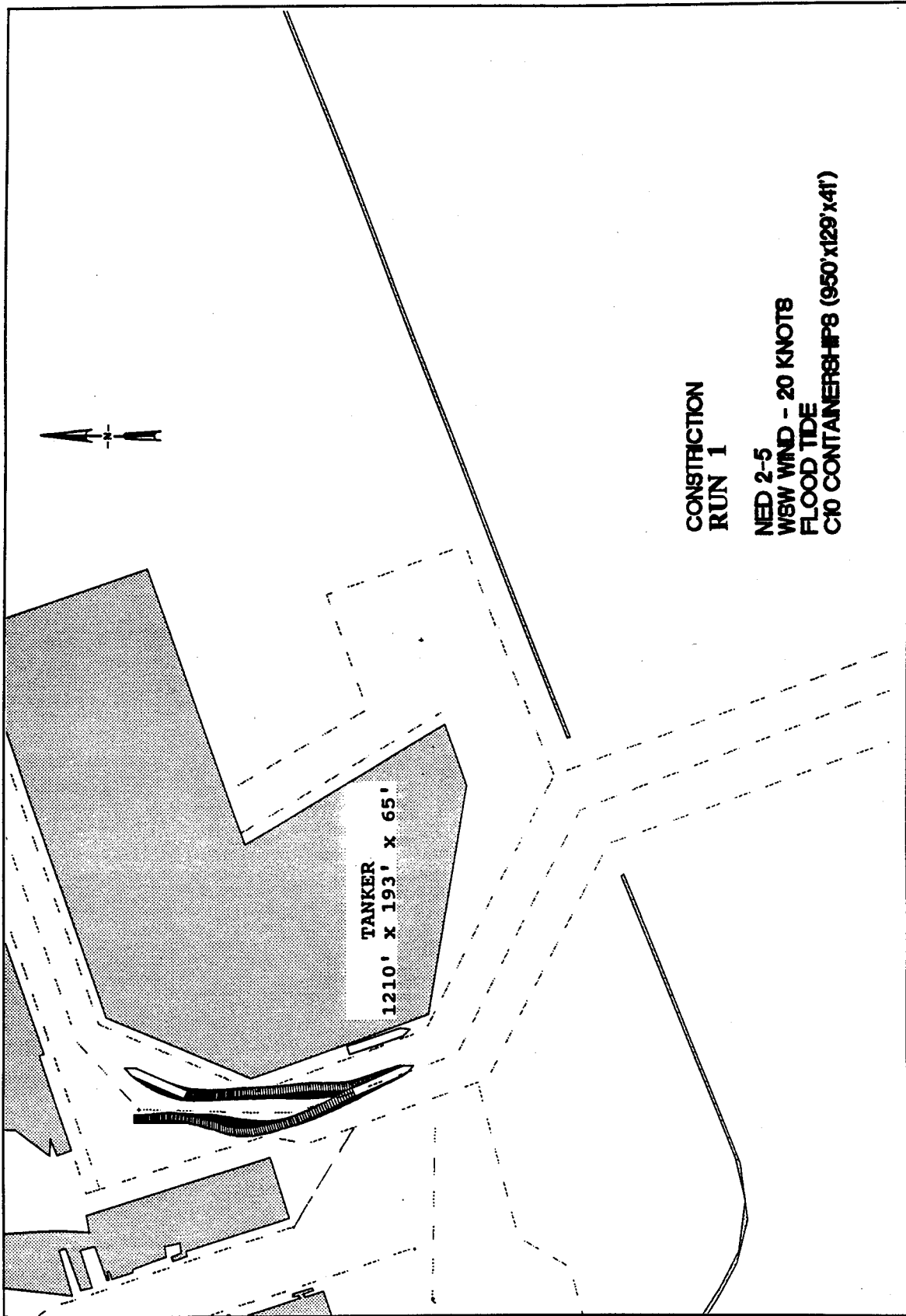

Plate 178



CONSTRUCTION  
RUN 1

NED 2-5  
WSW WIND - 20 KNOTS  
FLOOD TIDE  
C10 CONTAINERSHIP8 (950'x129'x41')

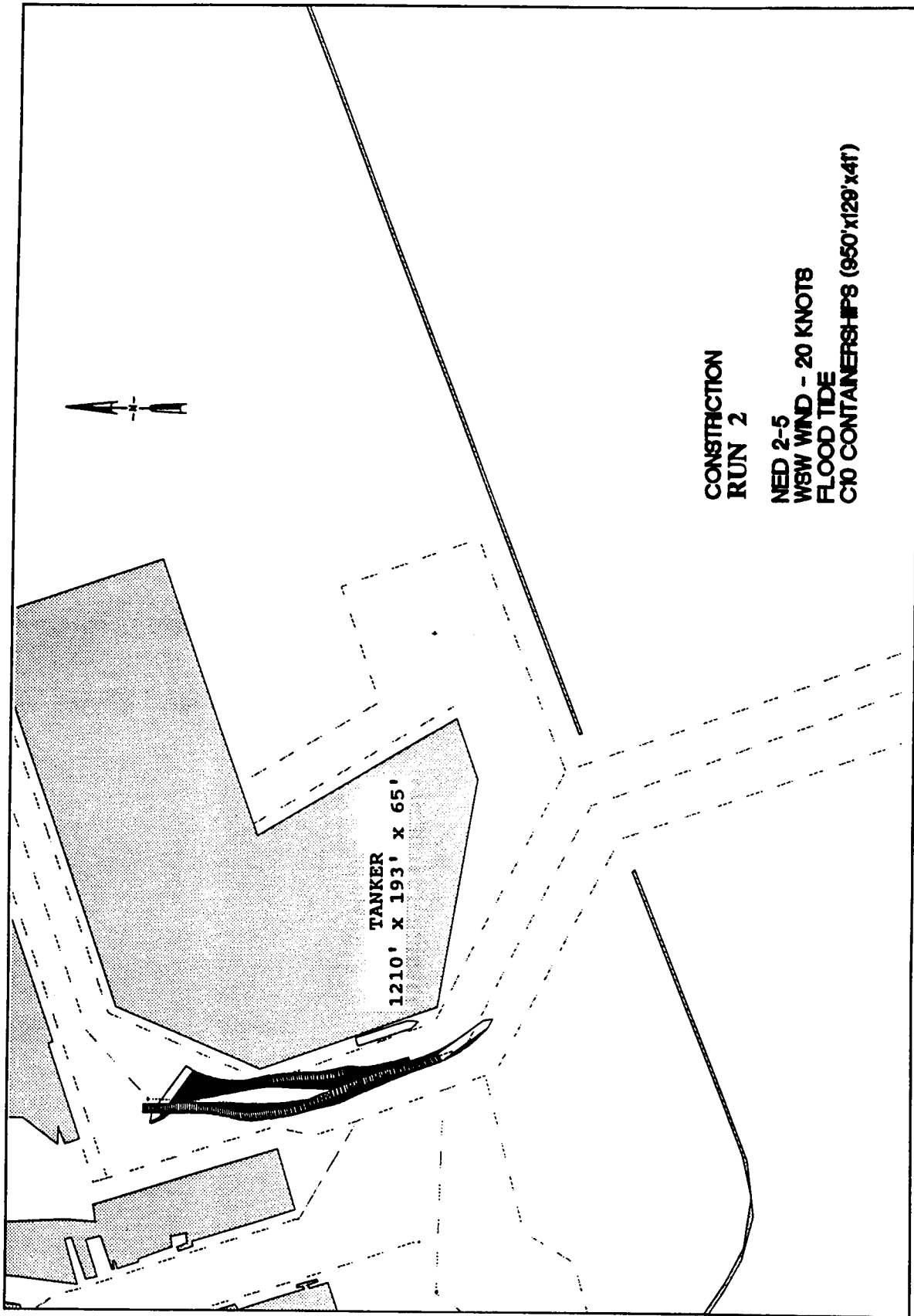

Plate 180

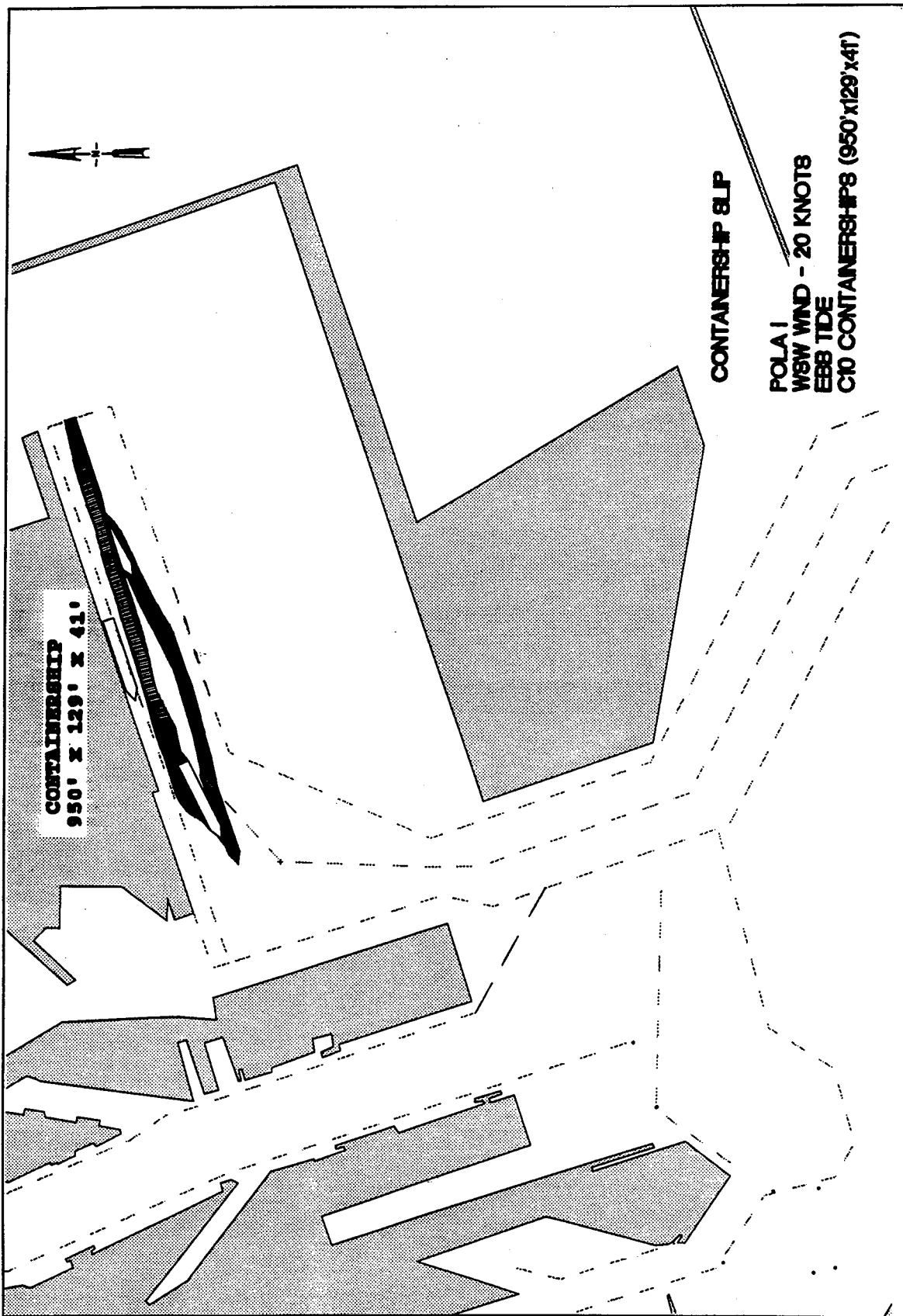

Plate 181

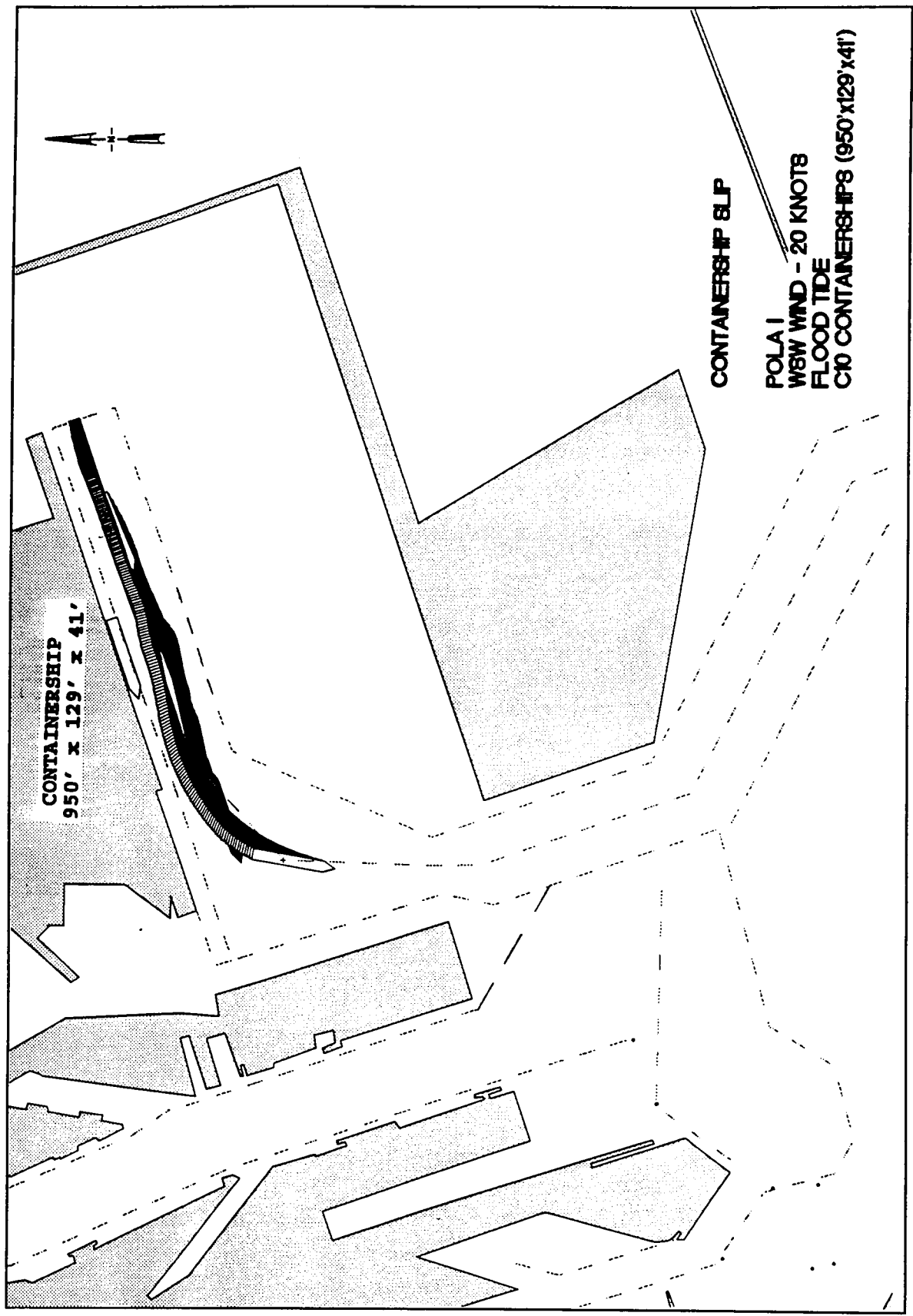
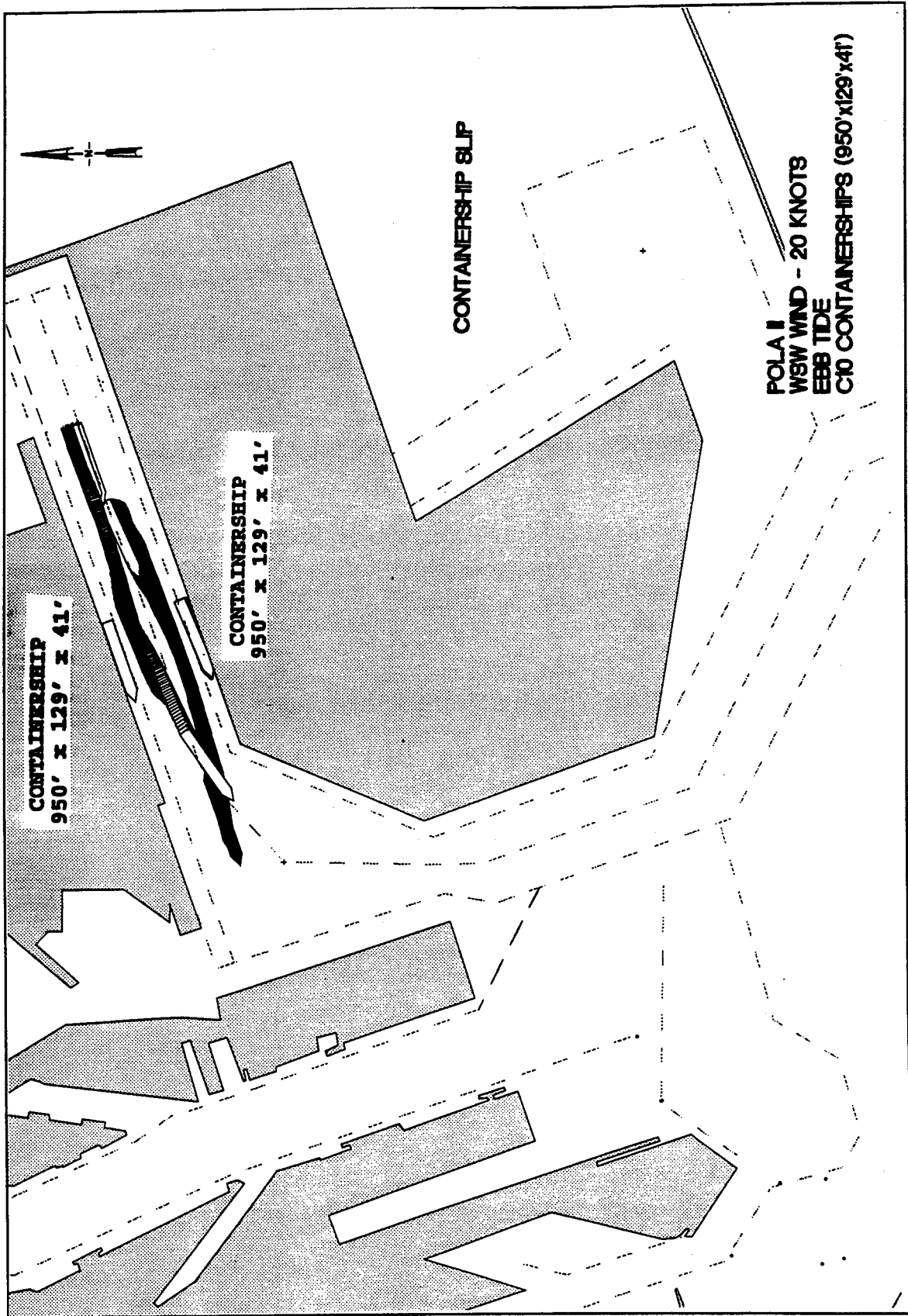

Plate 182



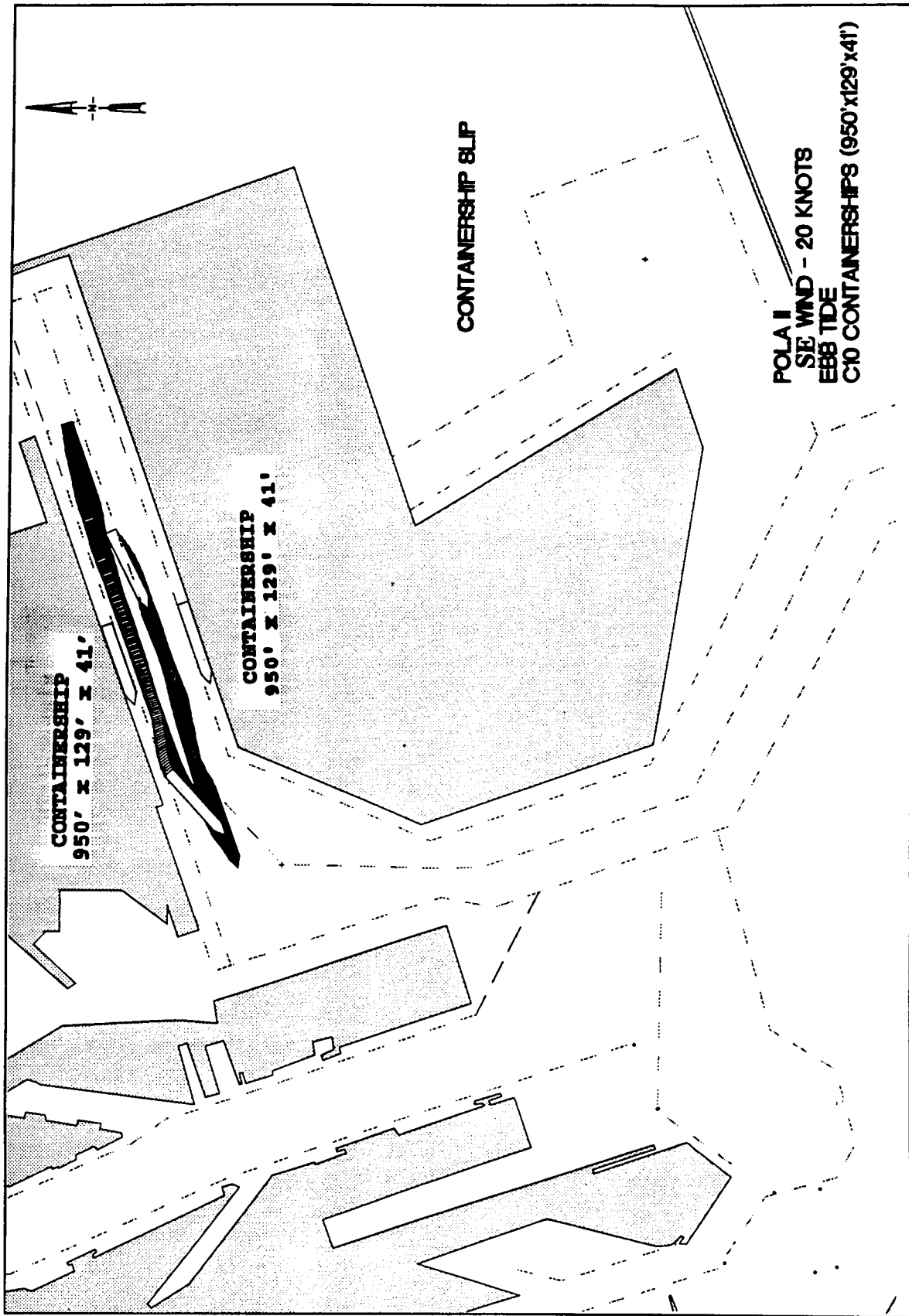
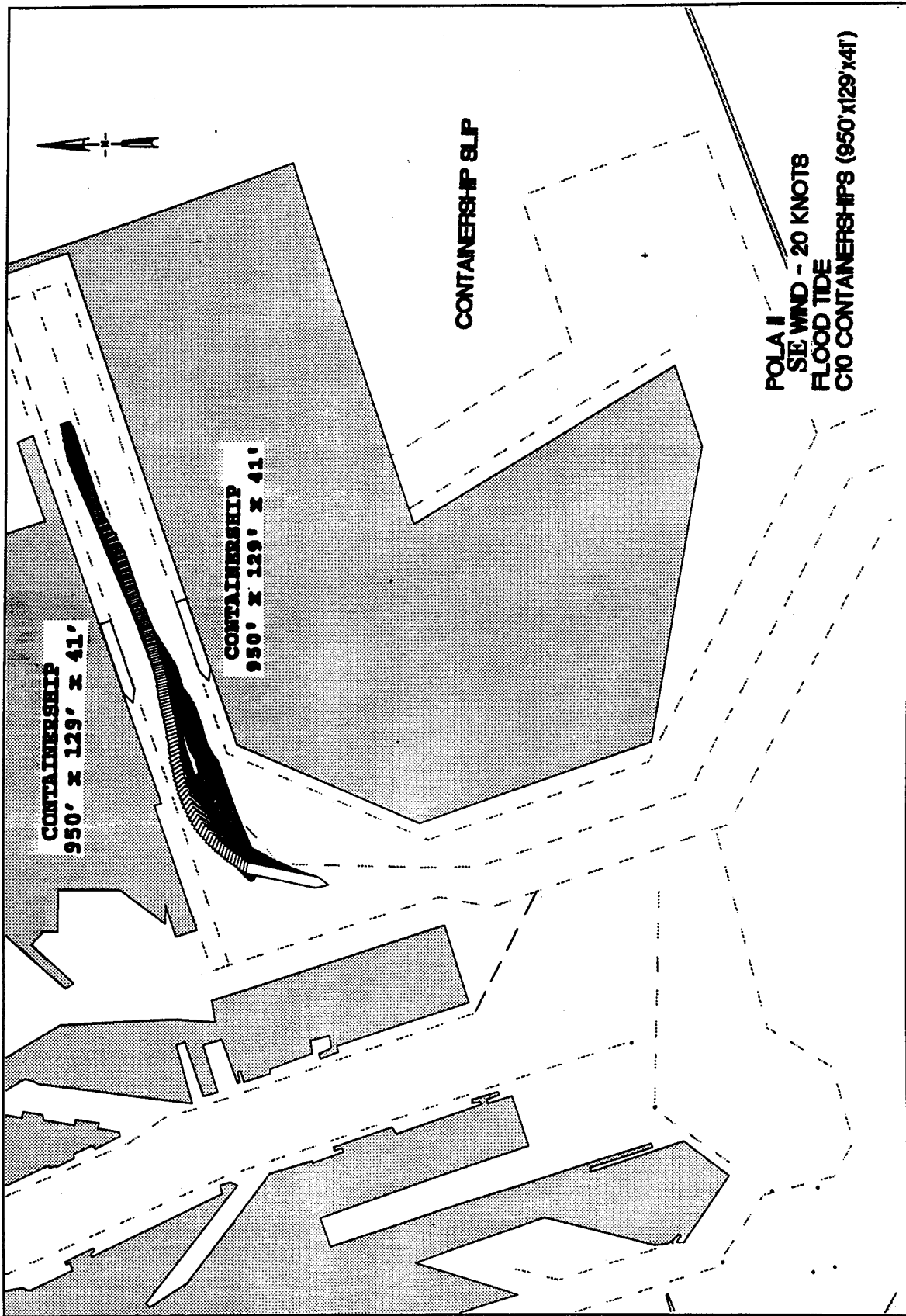

Plate 184



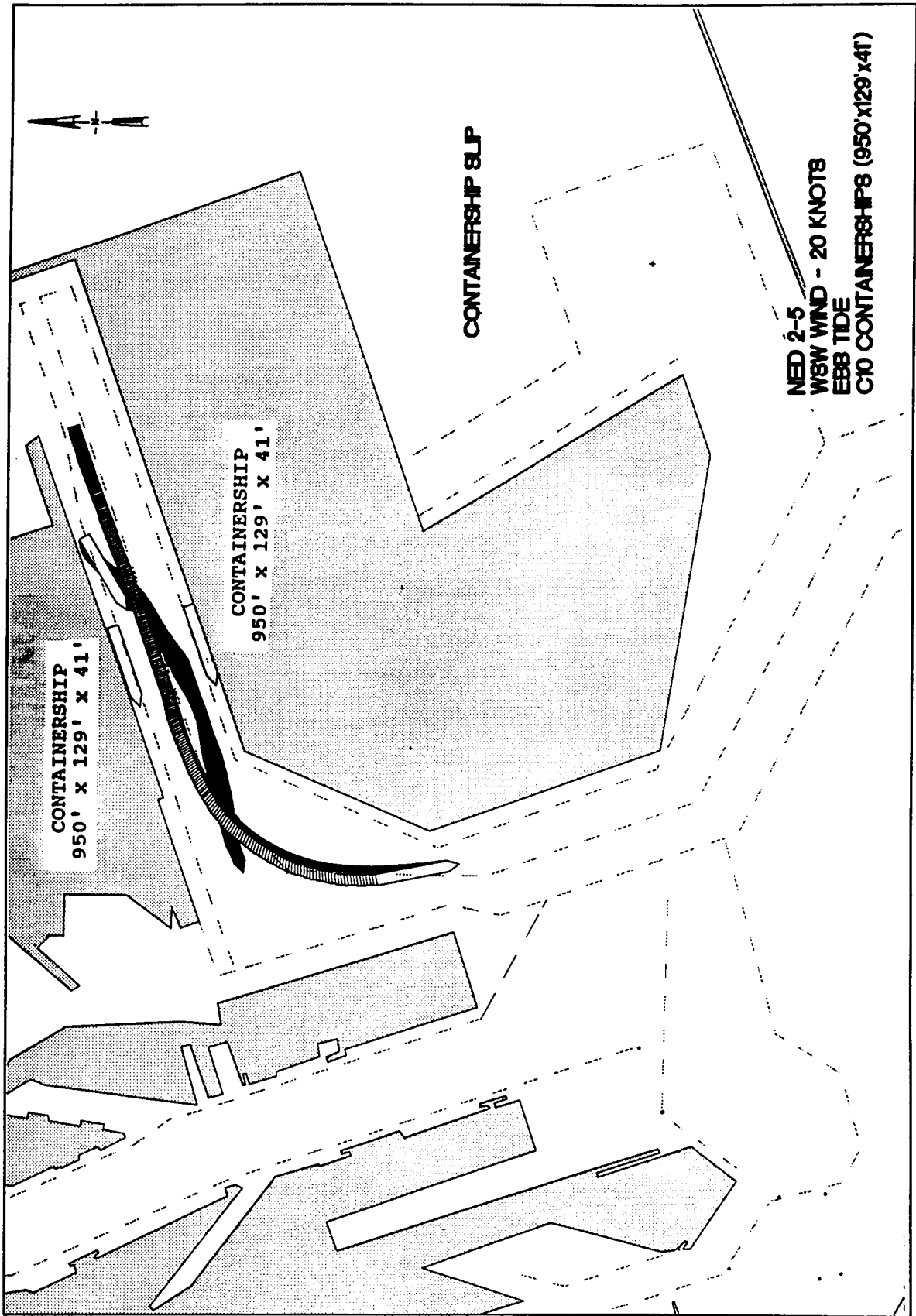

Plate 186

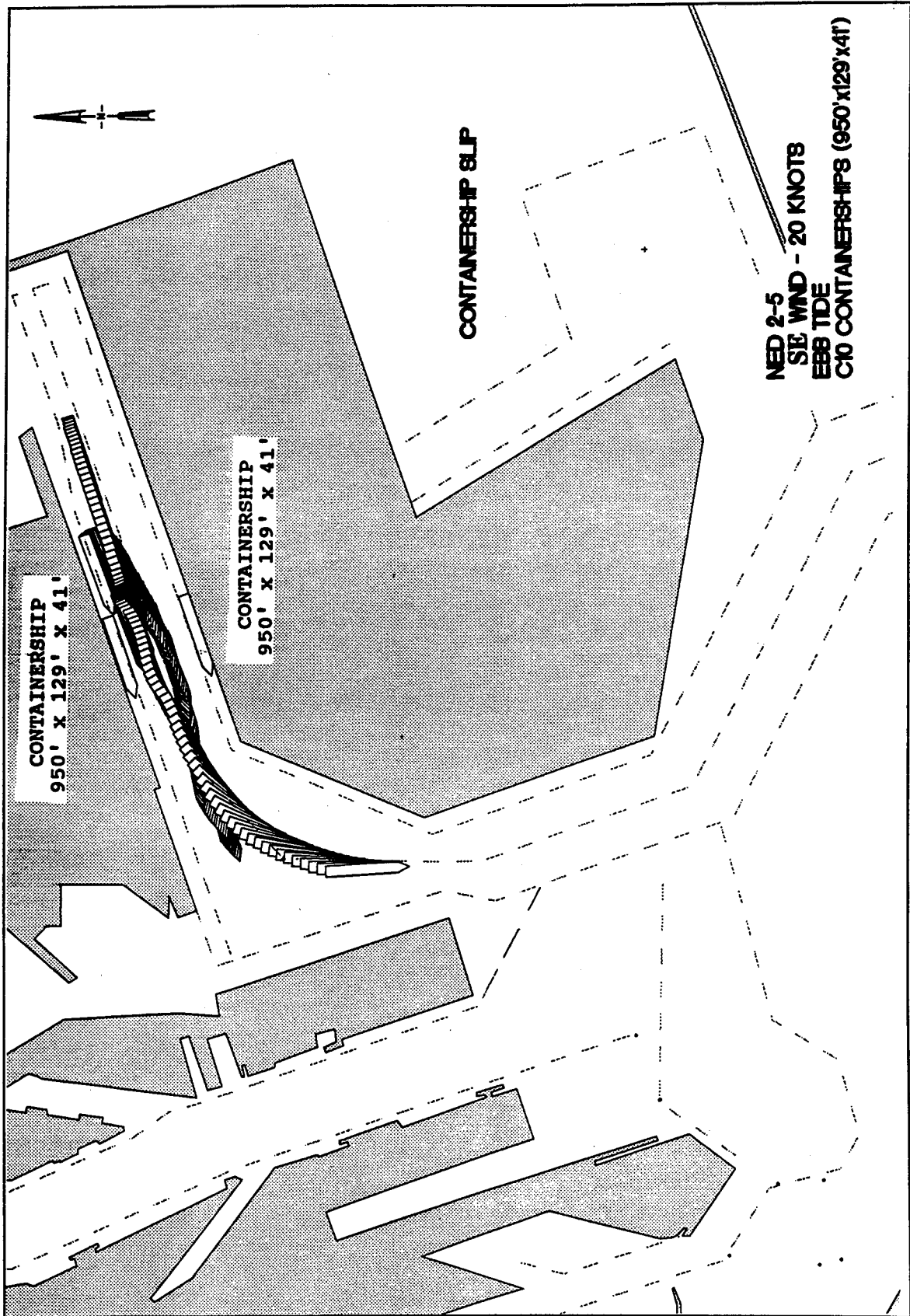

Plate 187

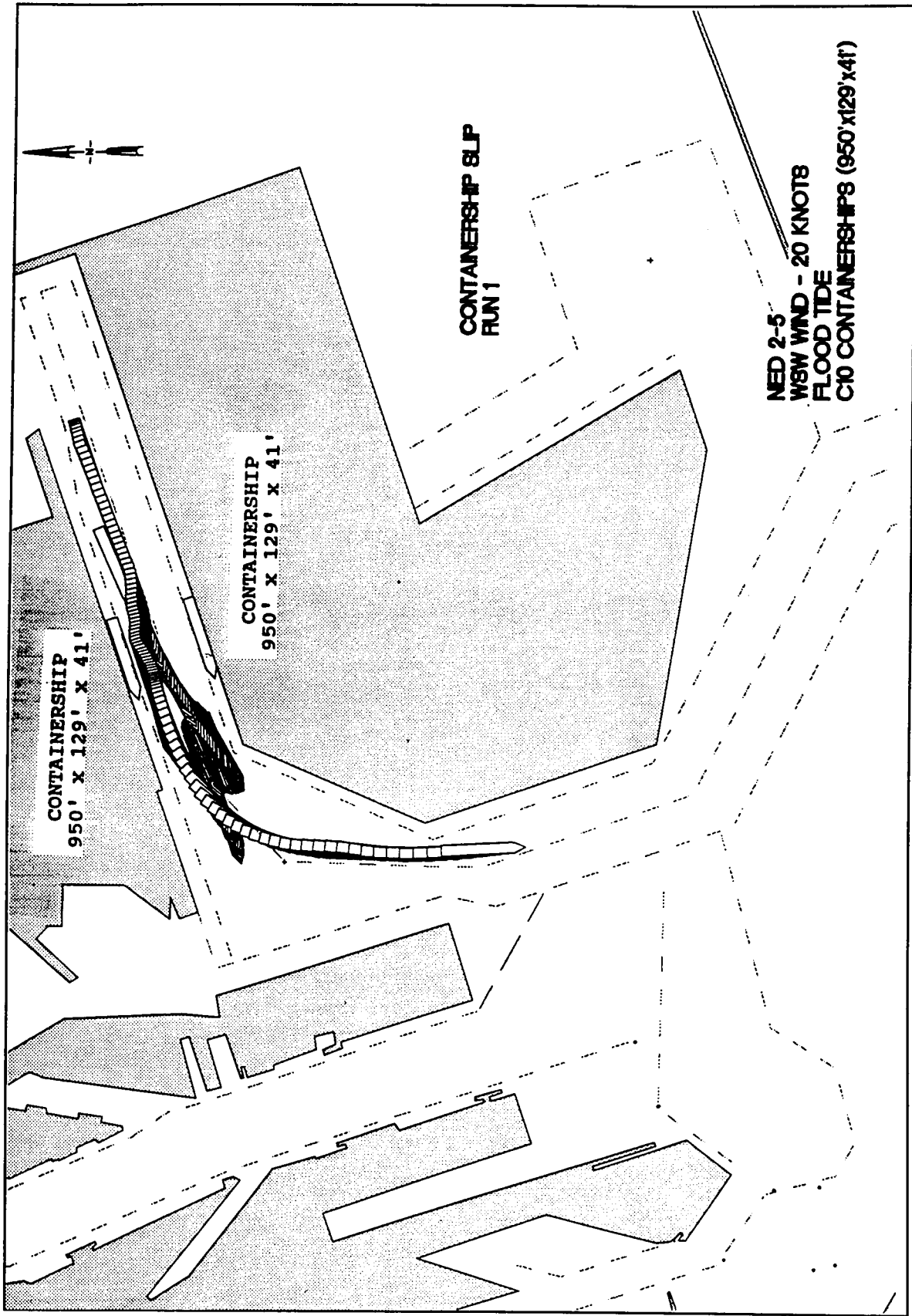
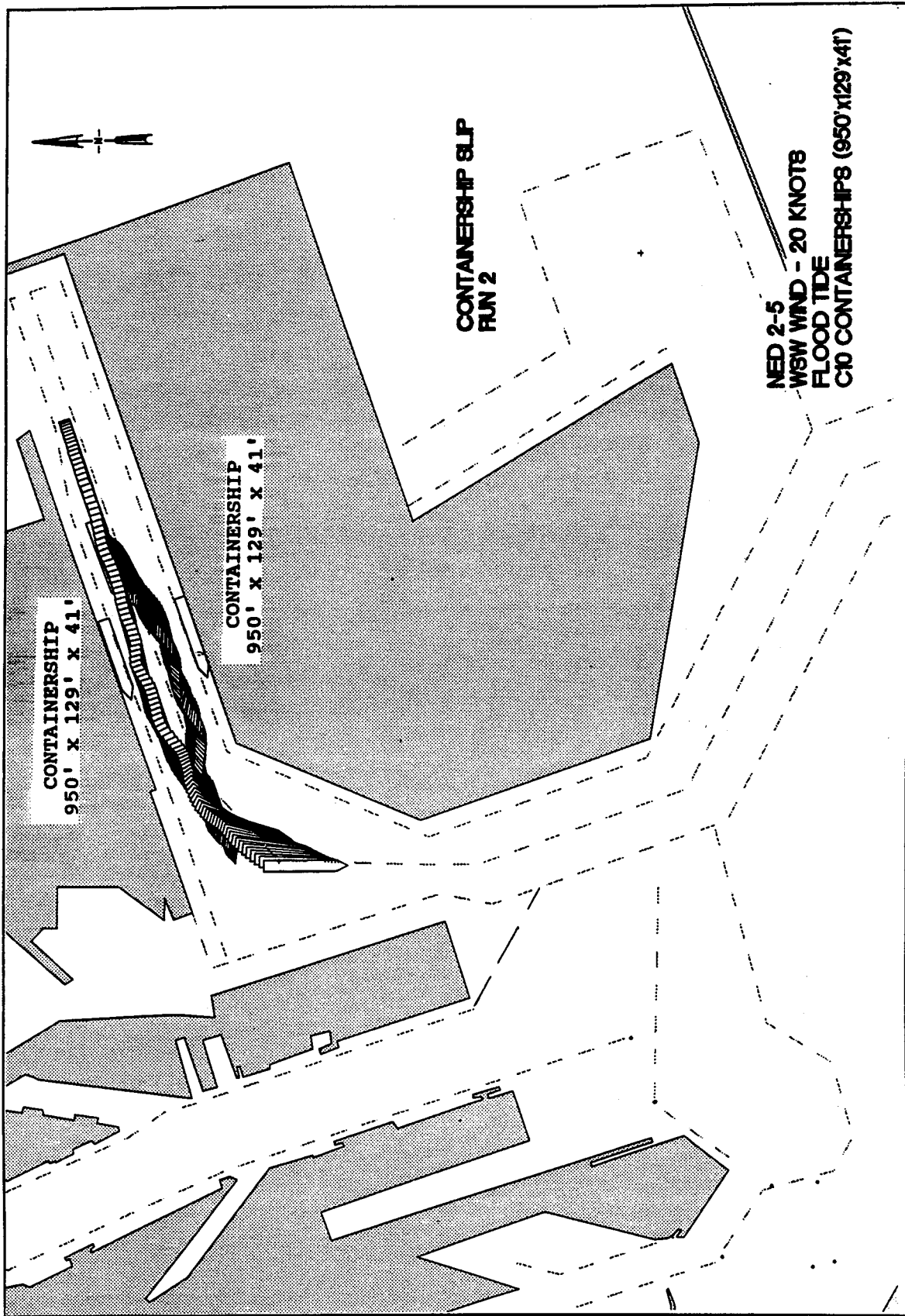

Plate 188



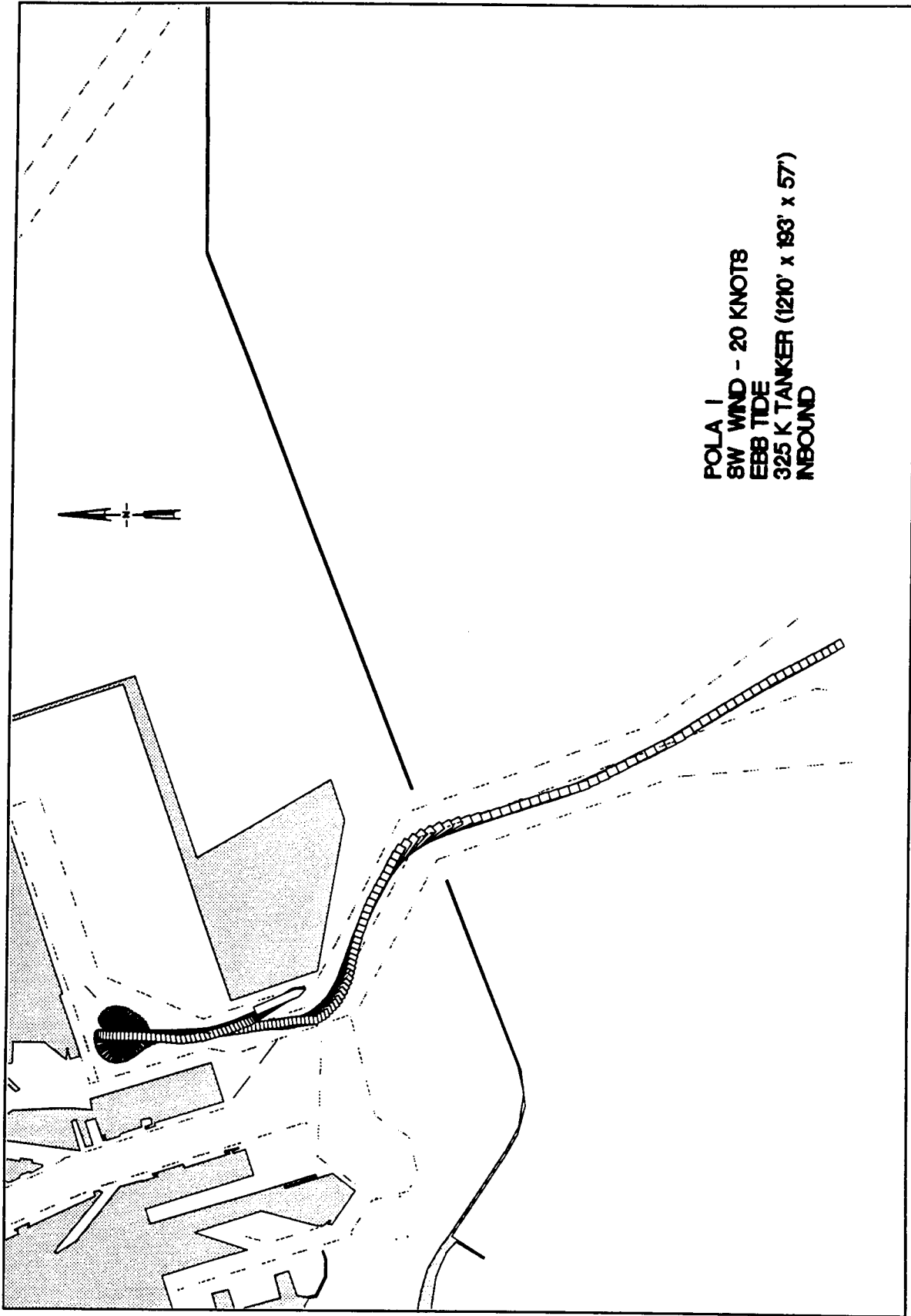

Plate 190

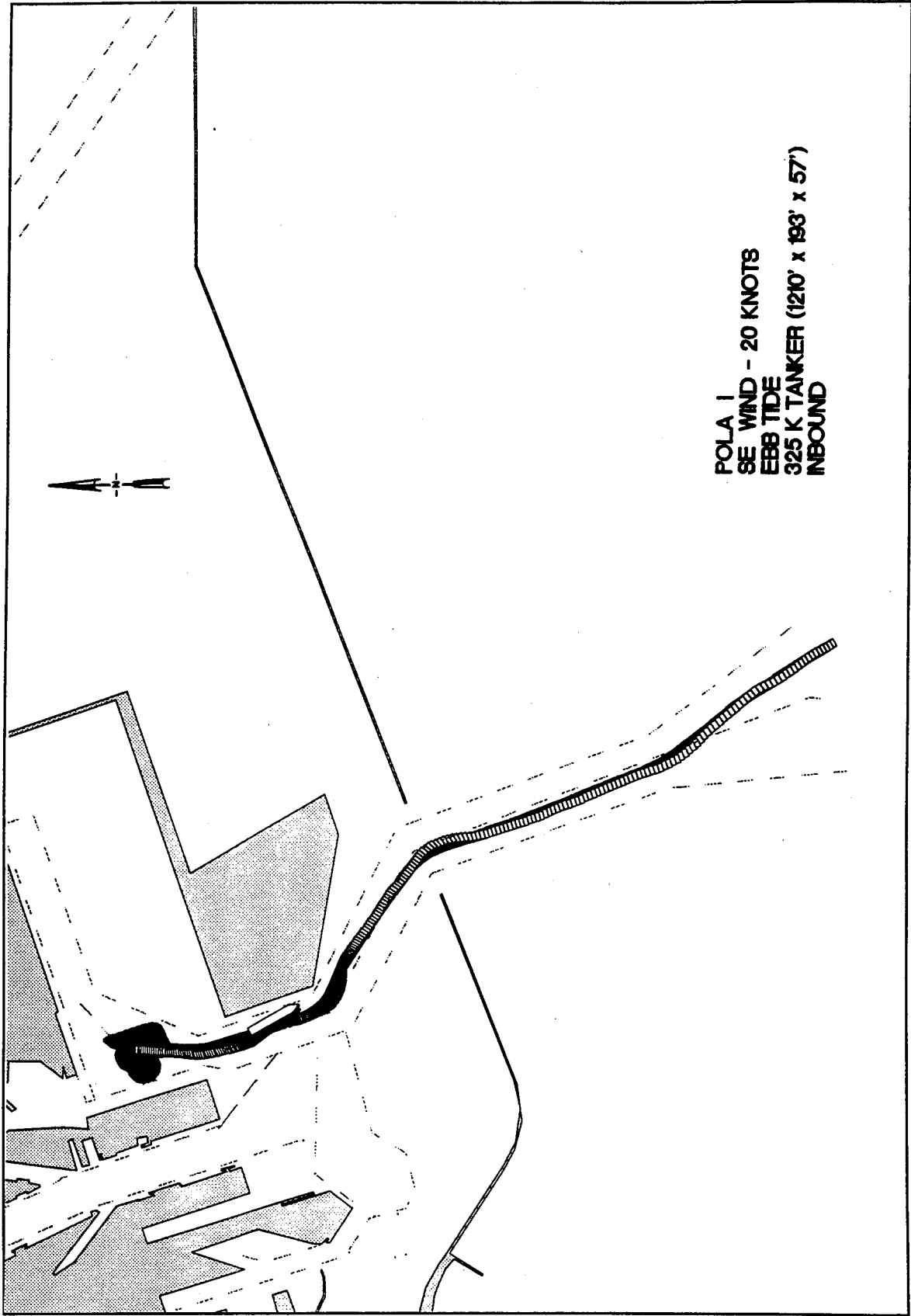
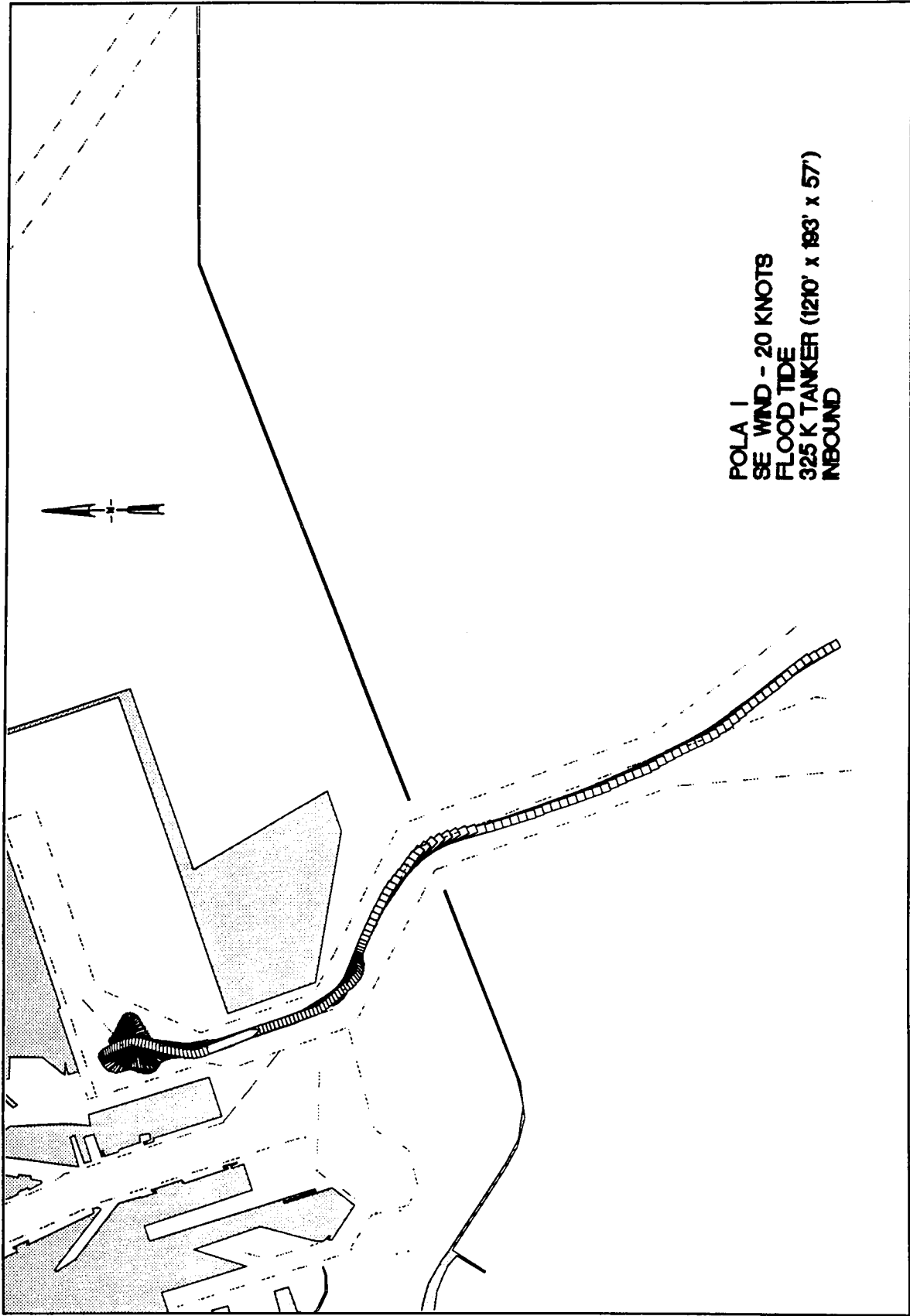
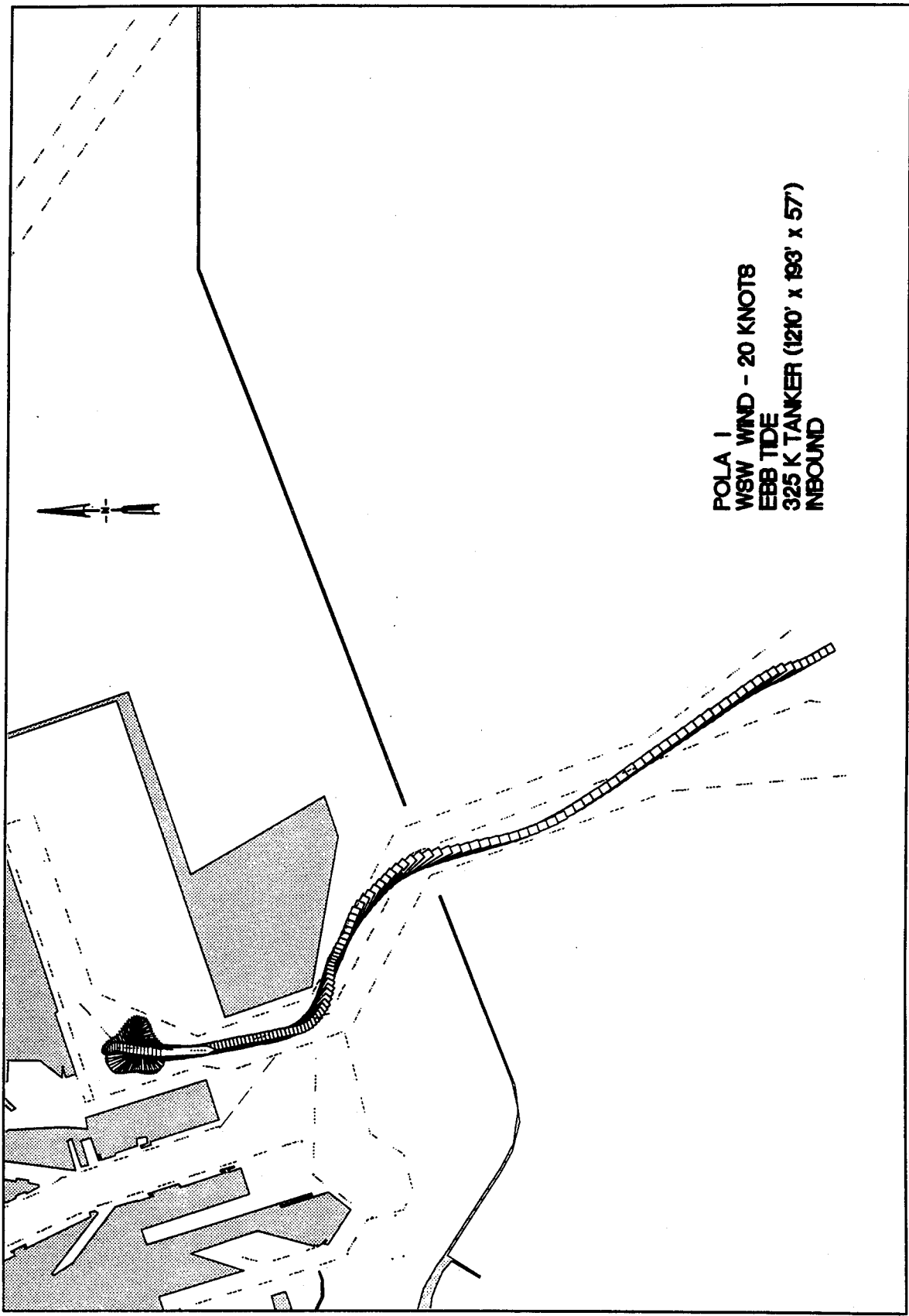

Plate 191



POLA I  
SE WIND - 20 KNOTS  
FLOOD TIDE  
325 K TANKER (1210' x 193' x 57')  
INBOUND

Plate 192



POLA I  
WSW WIND - 20 KNOTS  
EBB TIDE  
325 K TANKER (1210' x 193' x 57')  
INBOUND

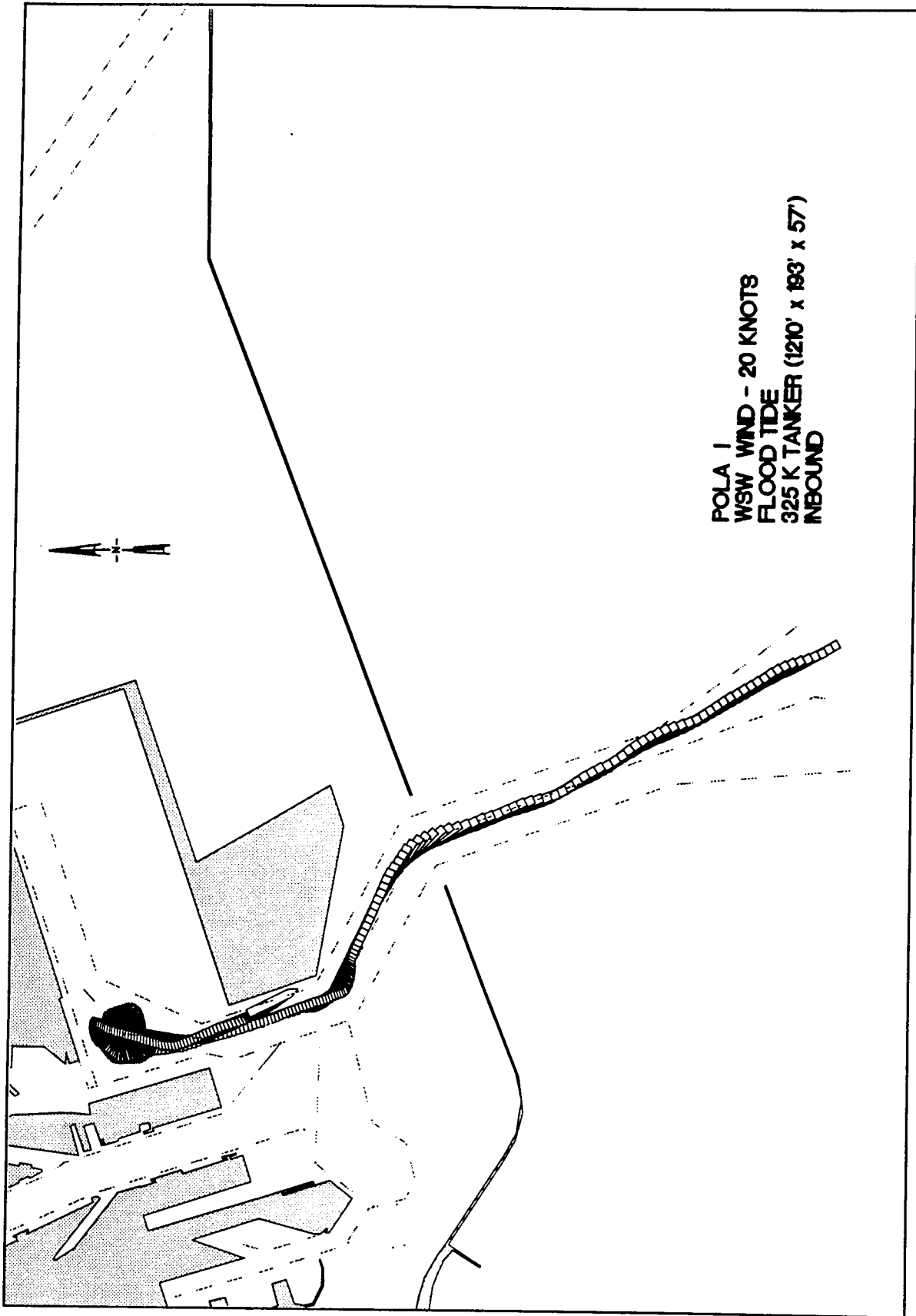

Plate 194

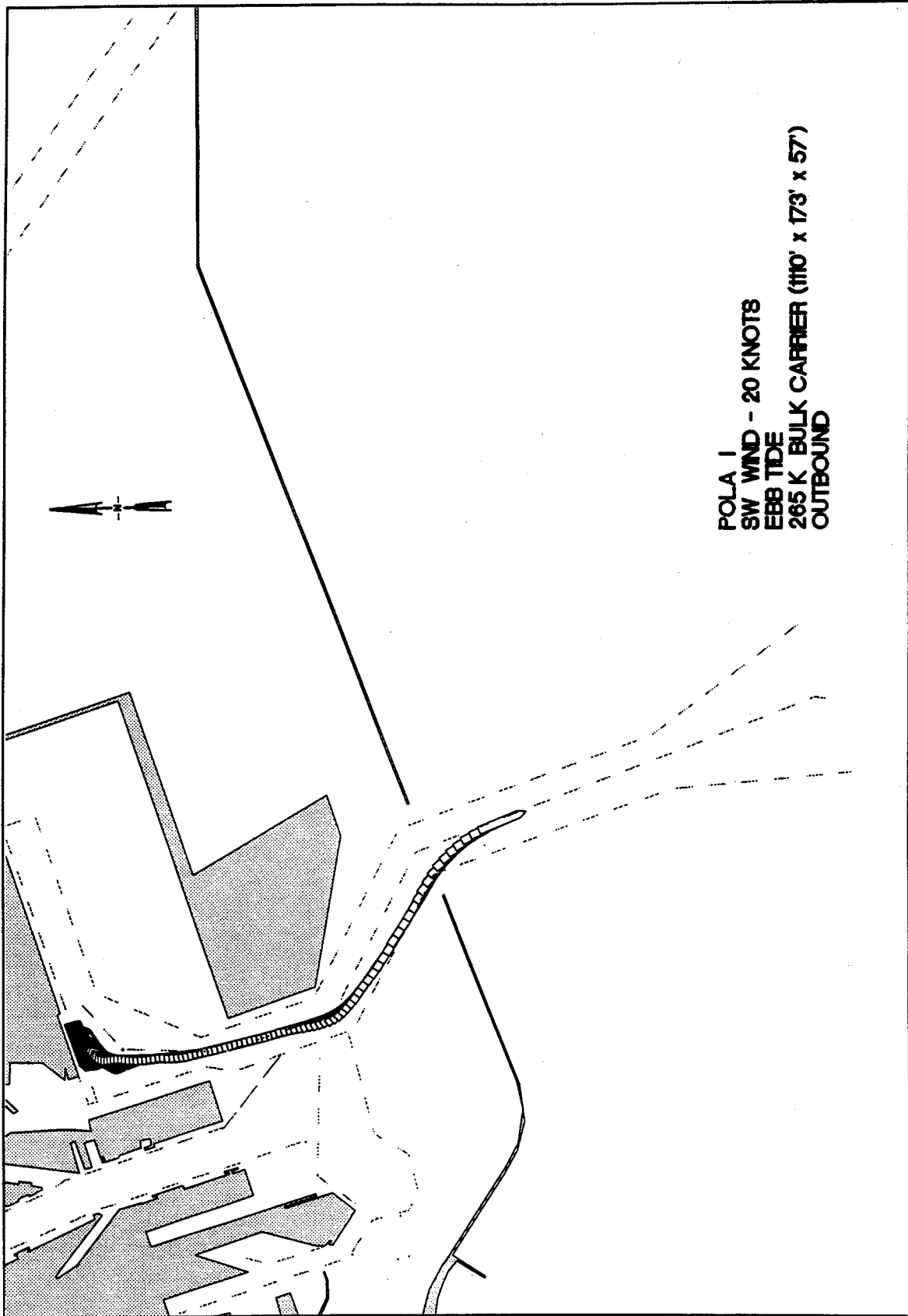
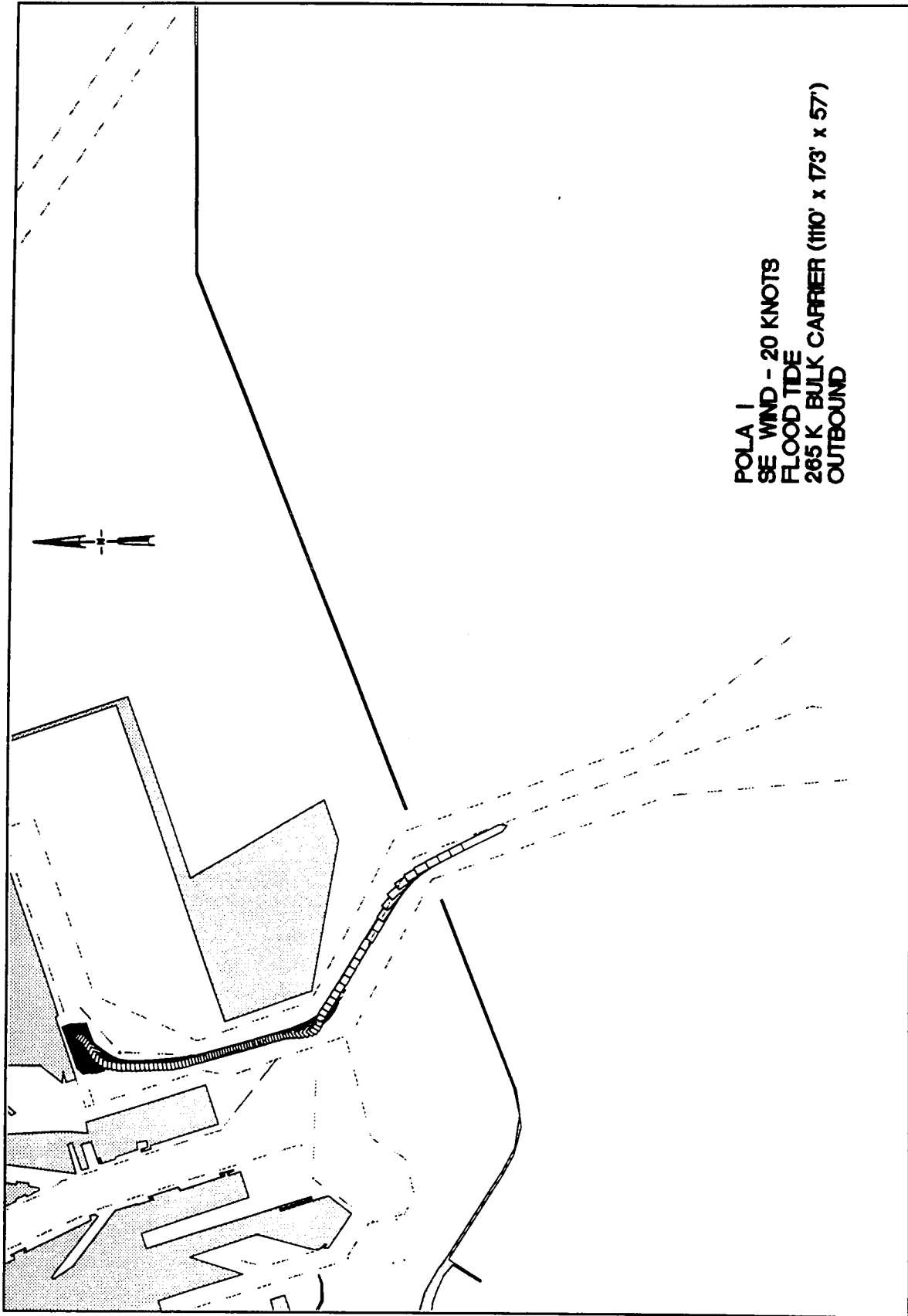
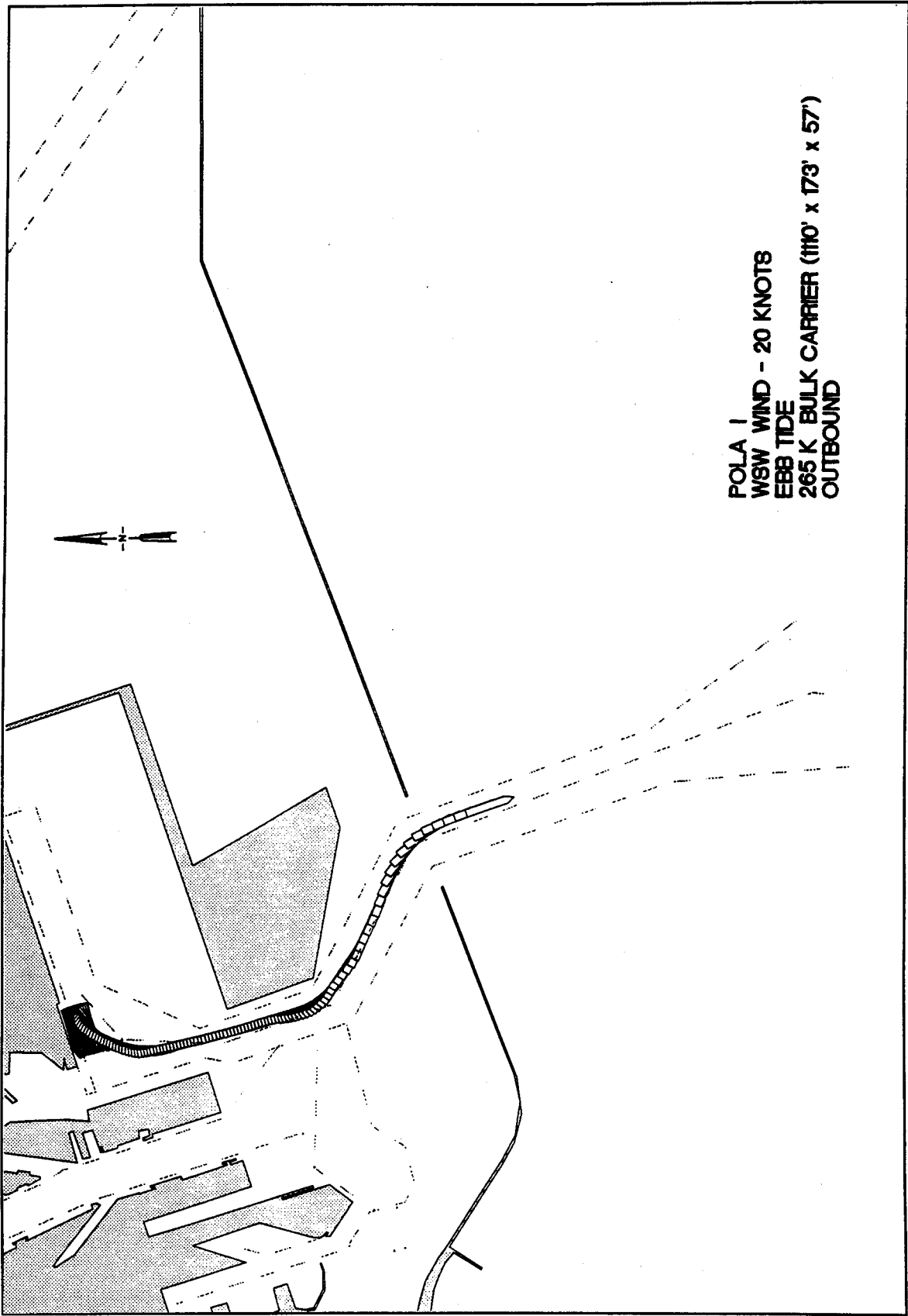

Plate 195



POLA 1  
SE WIND - 20 KNOTS  
FLOOD TIDE  
265 K BULK CARRIER (110' x 173' x 57')  
OUTBOUND

Plate 196



POLA I  
WSW WIND - 20 KNOTS  
EBB TIDE  
265 K BULK CARRIER (110' x 173' x 57')  
OUTBOUND

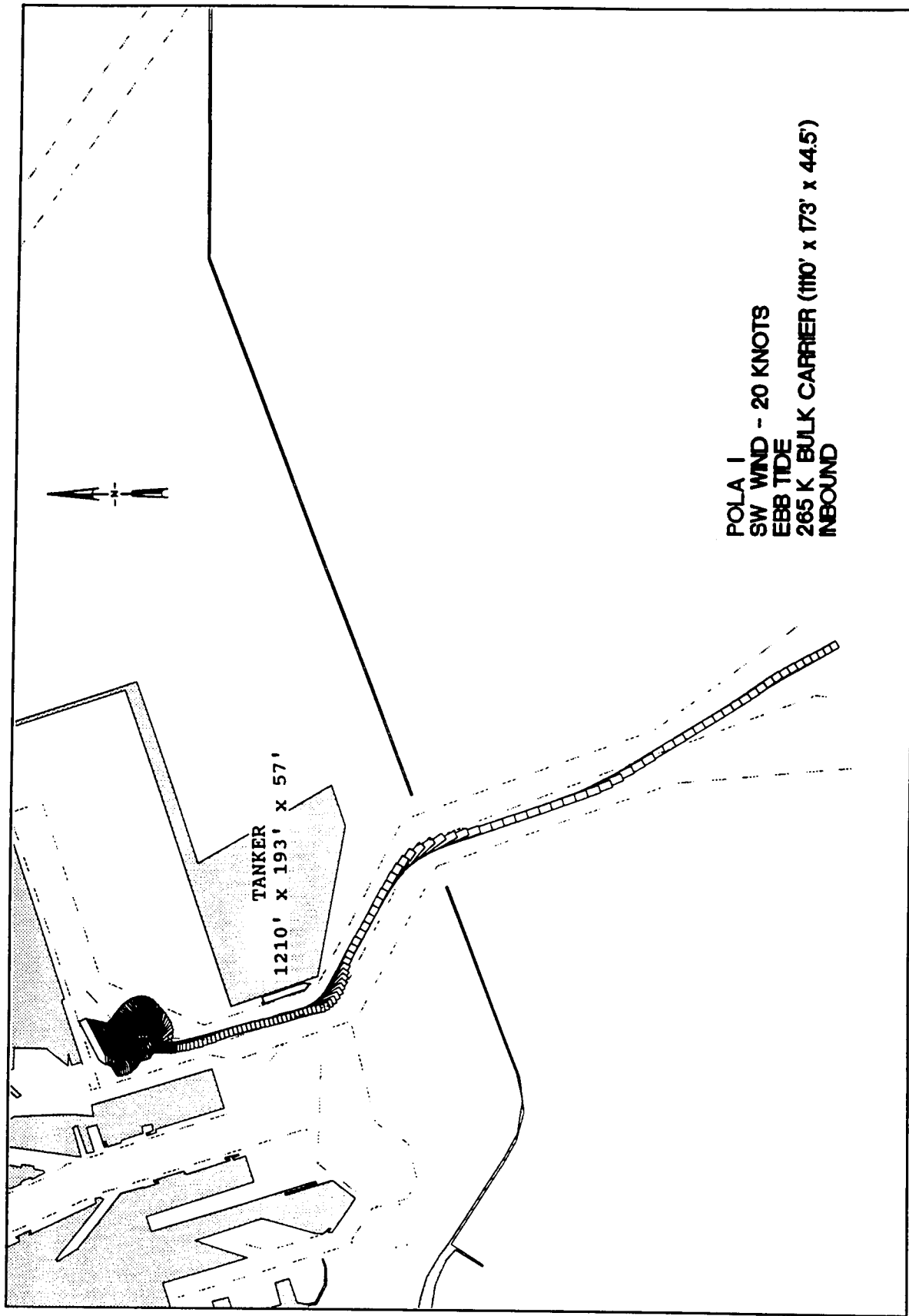

POLA I  
SW WIND - 20 KNOTS  
EBB TIDE  
265 K BULK CARRIER (1110' x 173' x 44.5')  
INBOUND

Plate 198

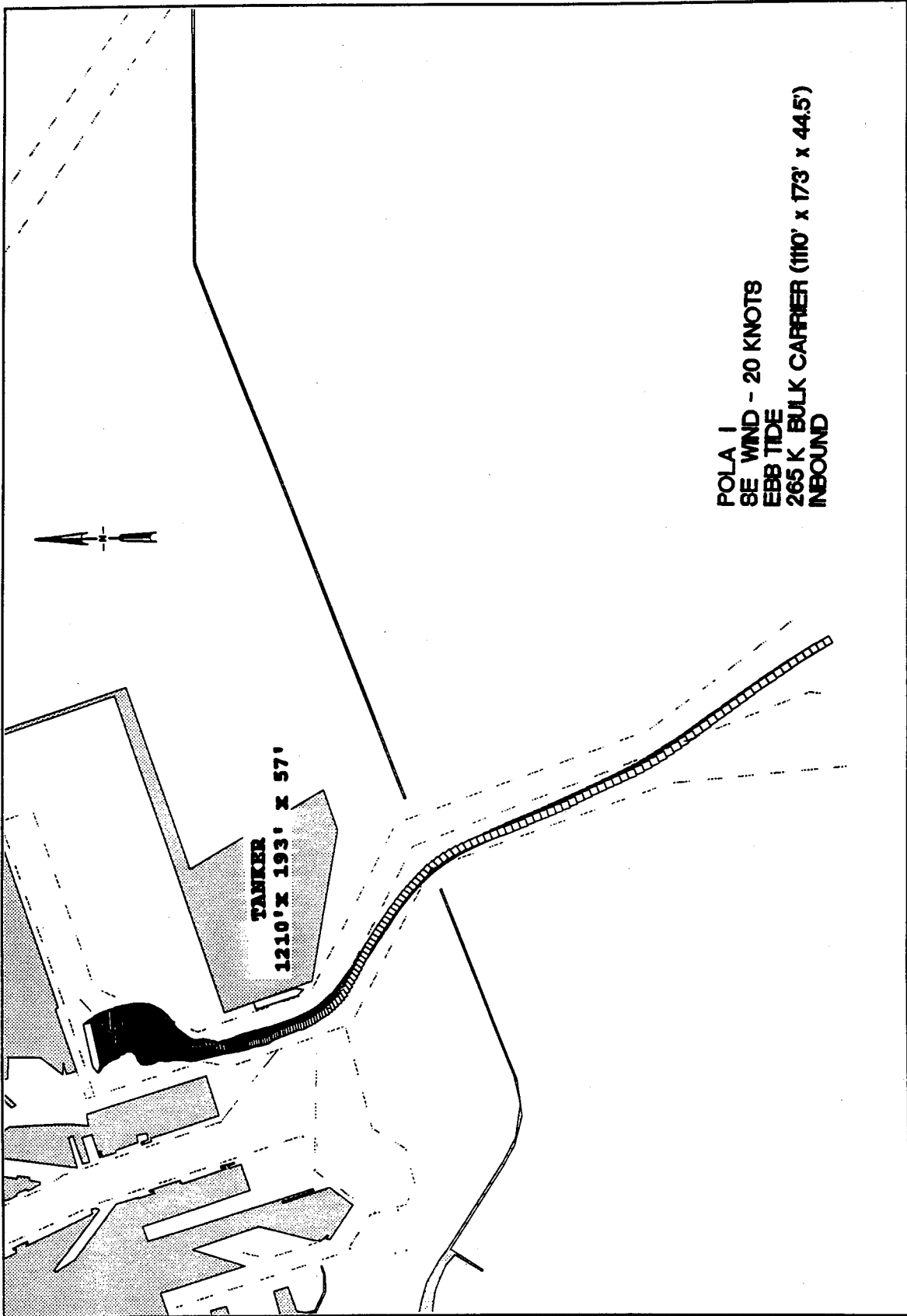

TANKER  
1210' x 193' x 57'

POLA I  
SE WIND - 20 KNOTS  
EBB TIDE  
265 K BULK CARRIER (1110' x 173' x 44.5')  
INBOUND

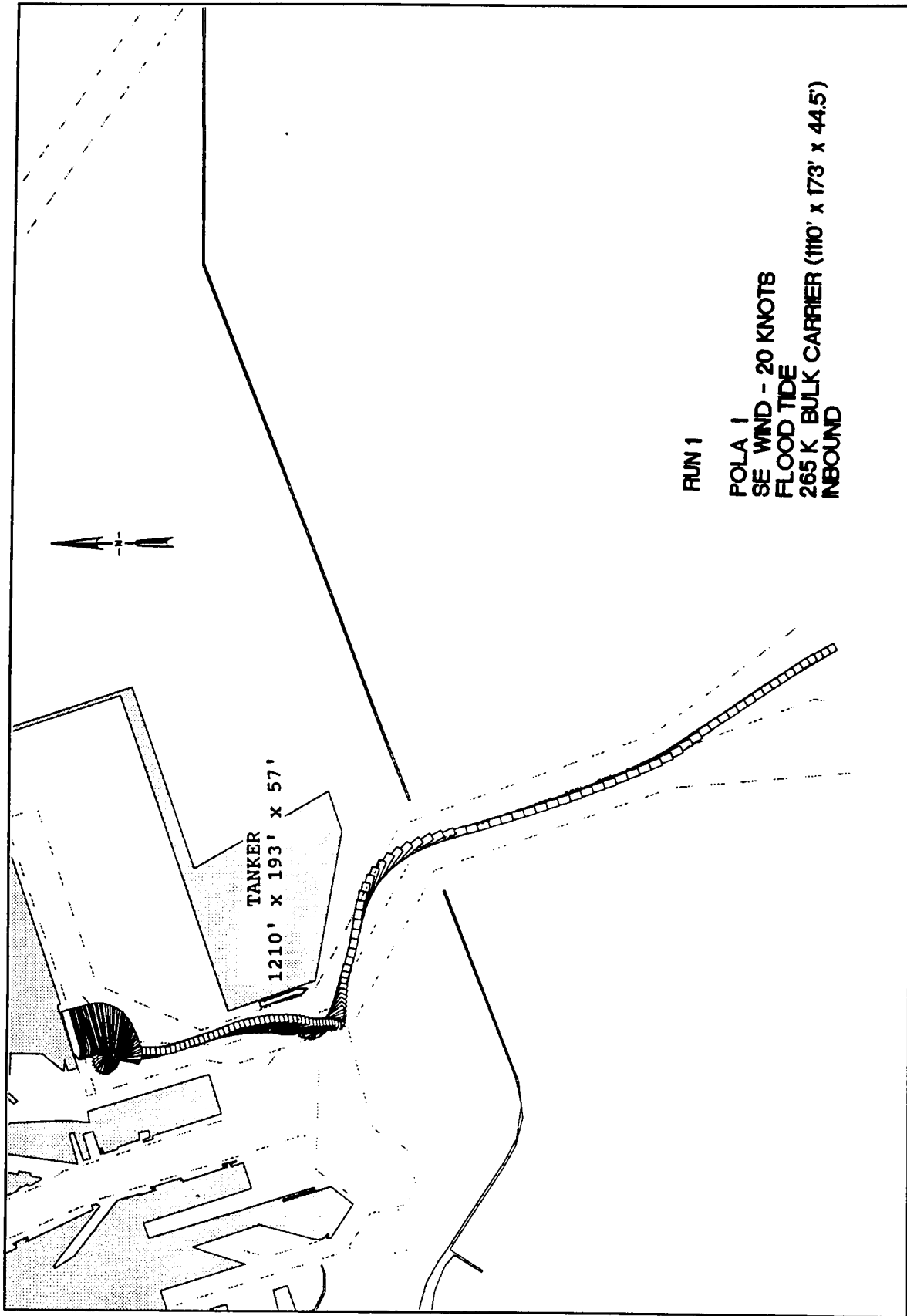
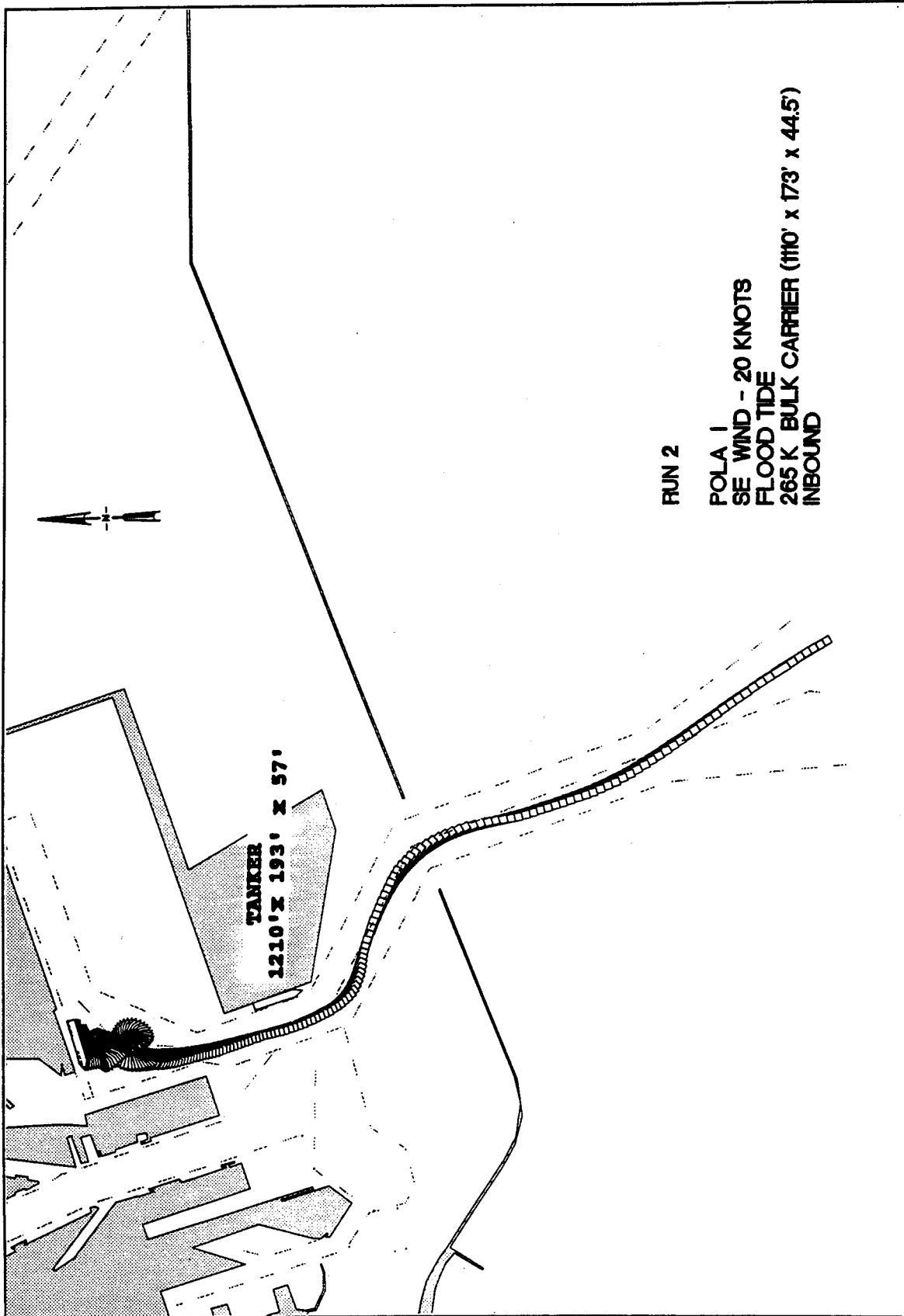

Plate 200



RUN 2

POLA 1  
SE WIND - 20 KNOTS  
FLOOD TIDE  
265 K BULK CARRIER (1110' x 173' x 44.5')  
INBOUND

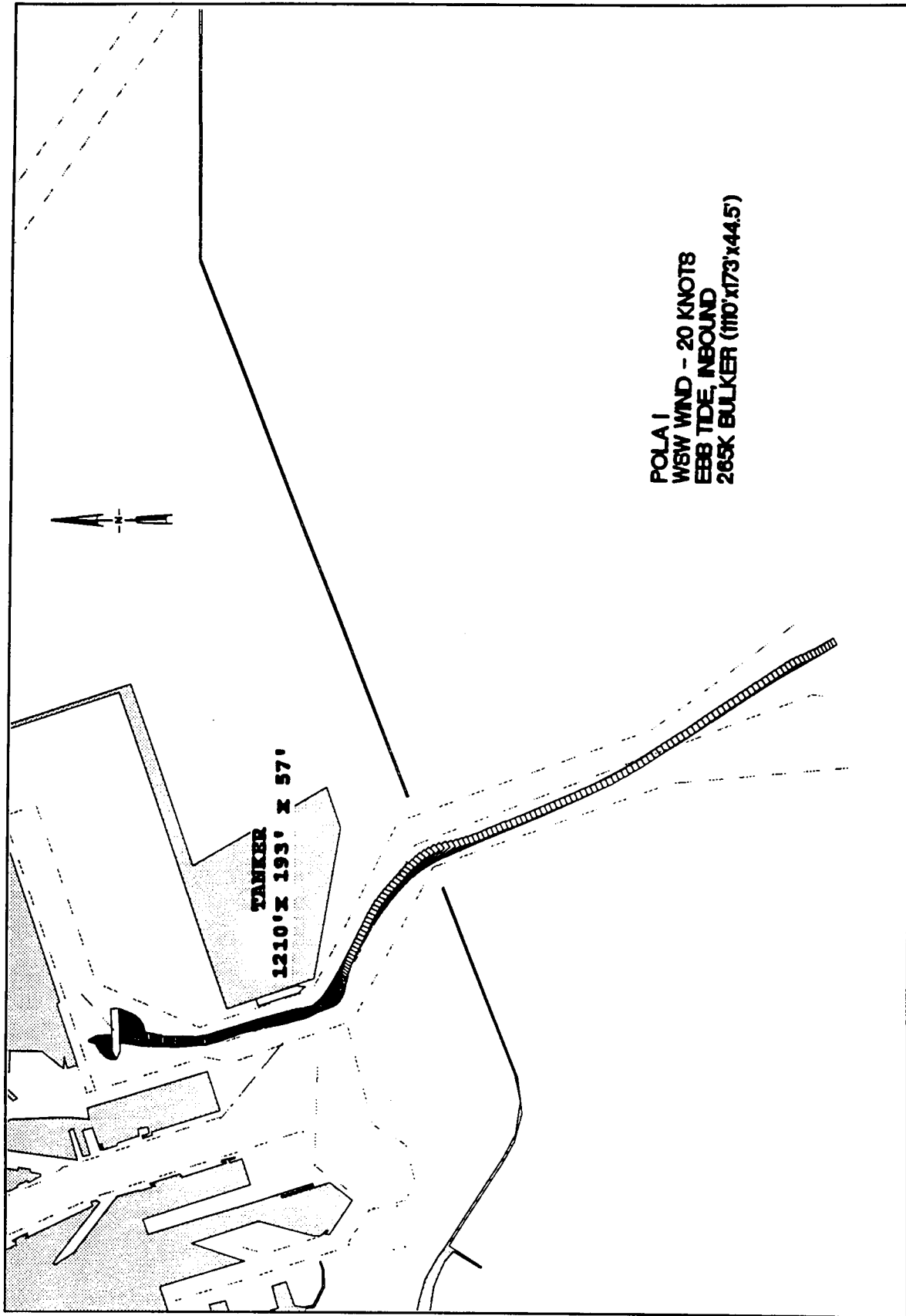
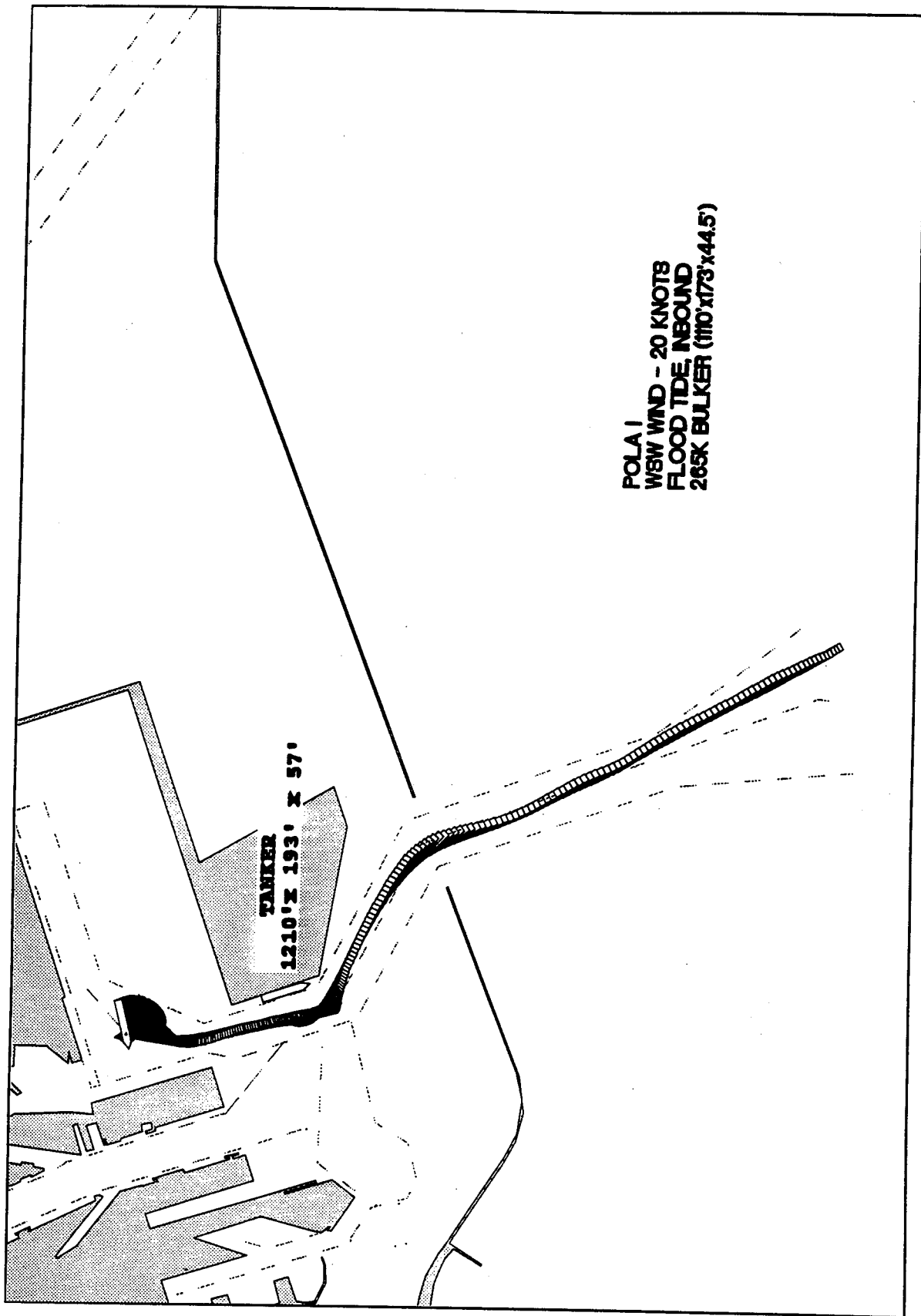

Plate 202



**POLA I**  
**WSW WIND - 20 KNOTS**  
**FLOOD TIDE, INBOUND**  
**265K BULKER (1110'x173'x44.5')**

**TANKER**  
**1210'x 193' x 57'**

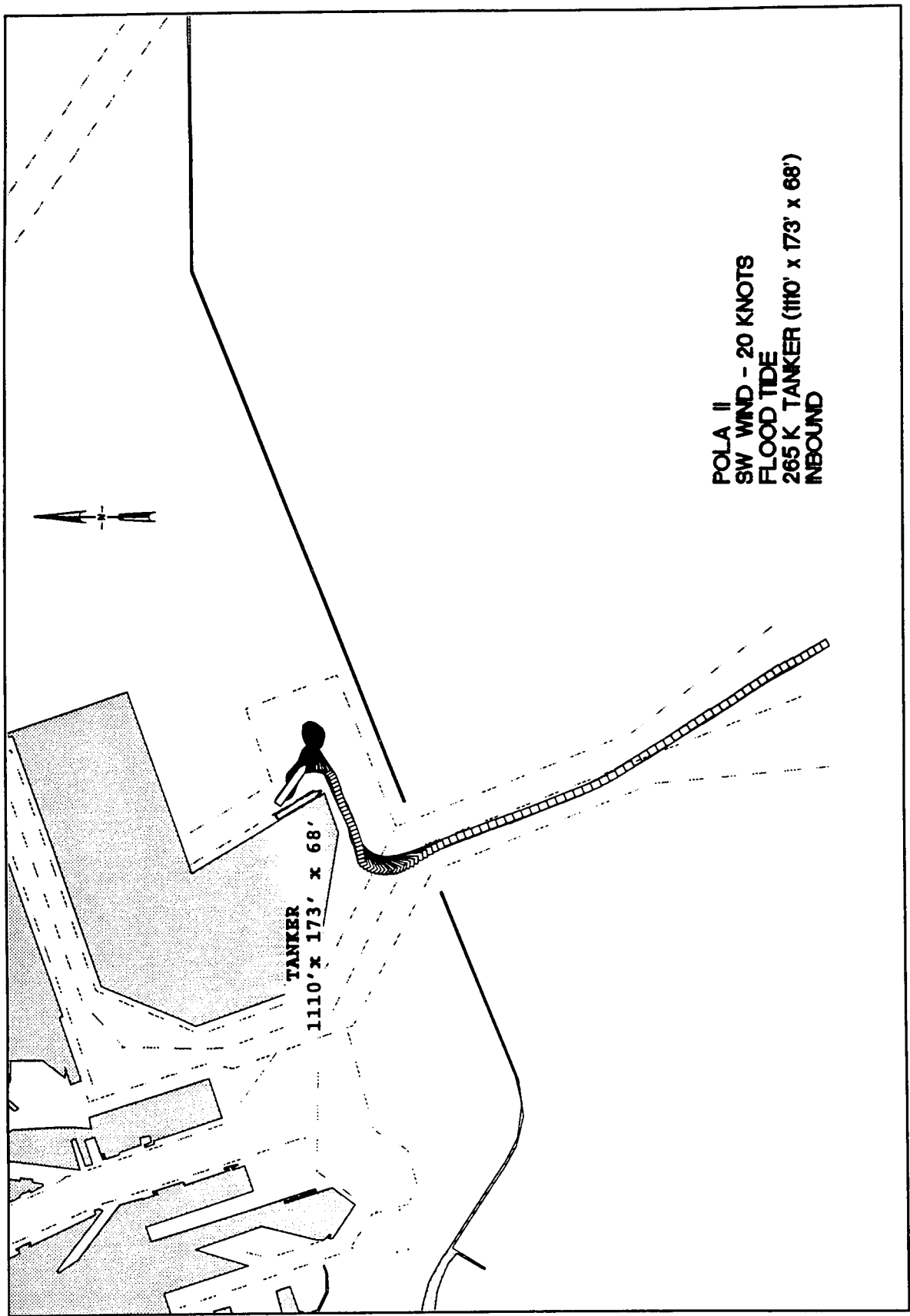
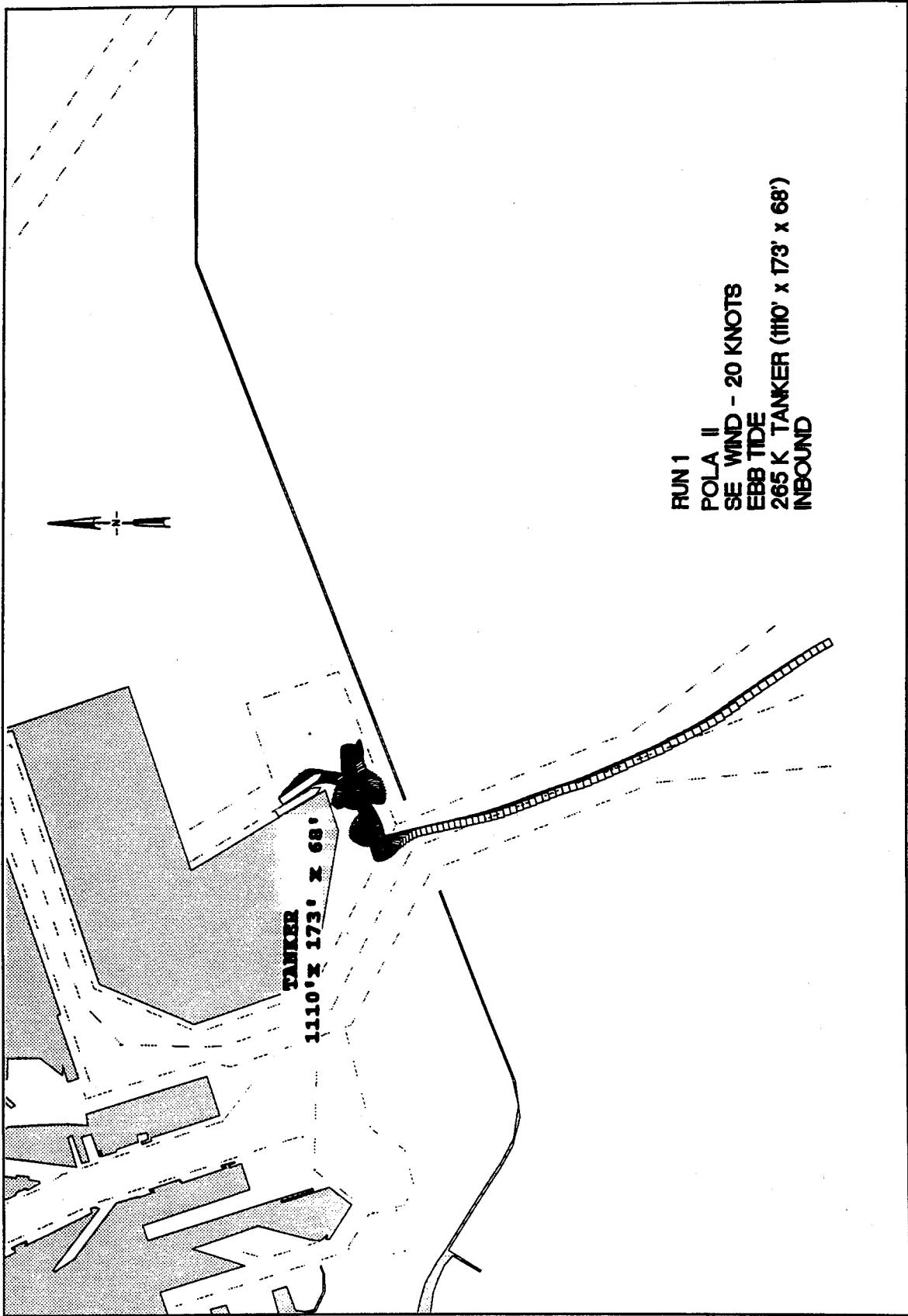

Plate 204



RUN 1  
POLA II  
SE WIND - 20 KNOTS  
EBB TIDE  
265 K TANKER (1110' x 173' x 68')  
INBOUND

TANKER  
1110' x 173' x 68'

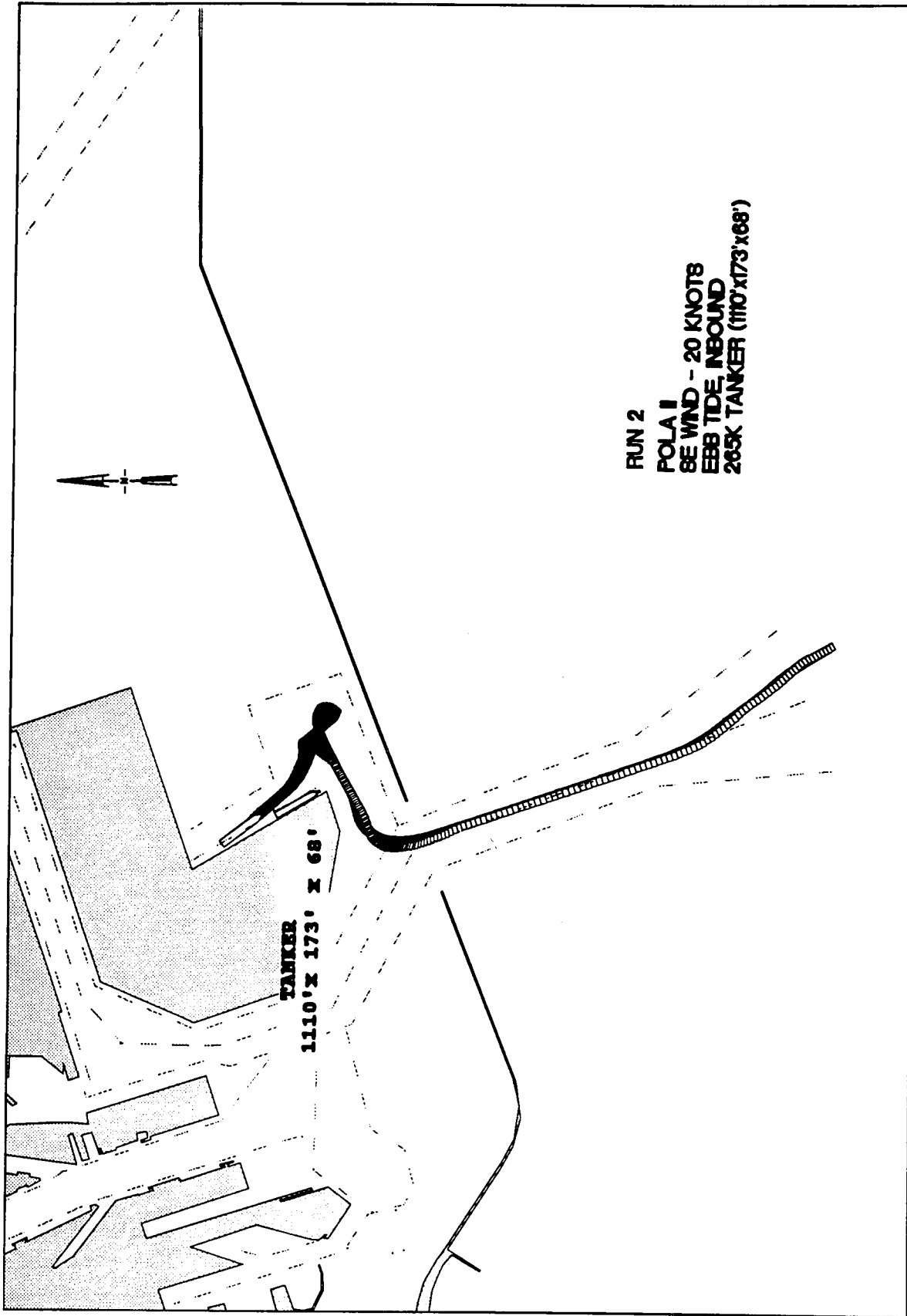
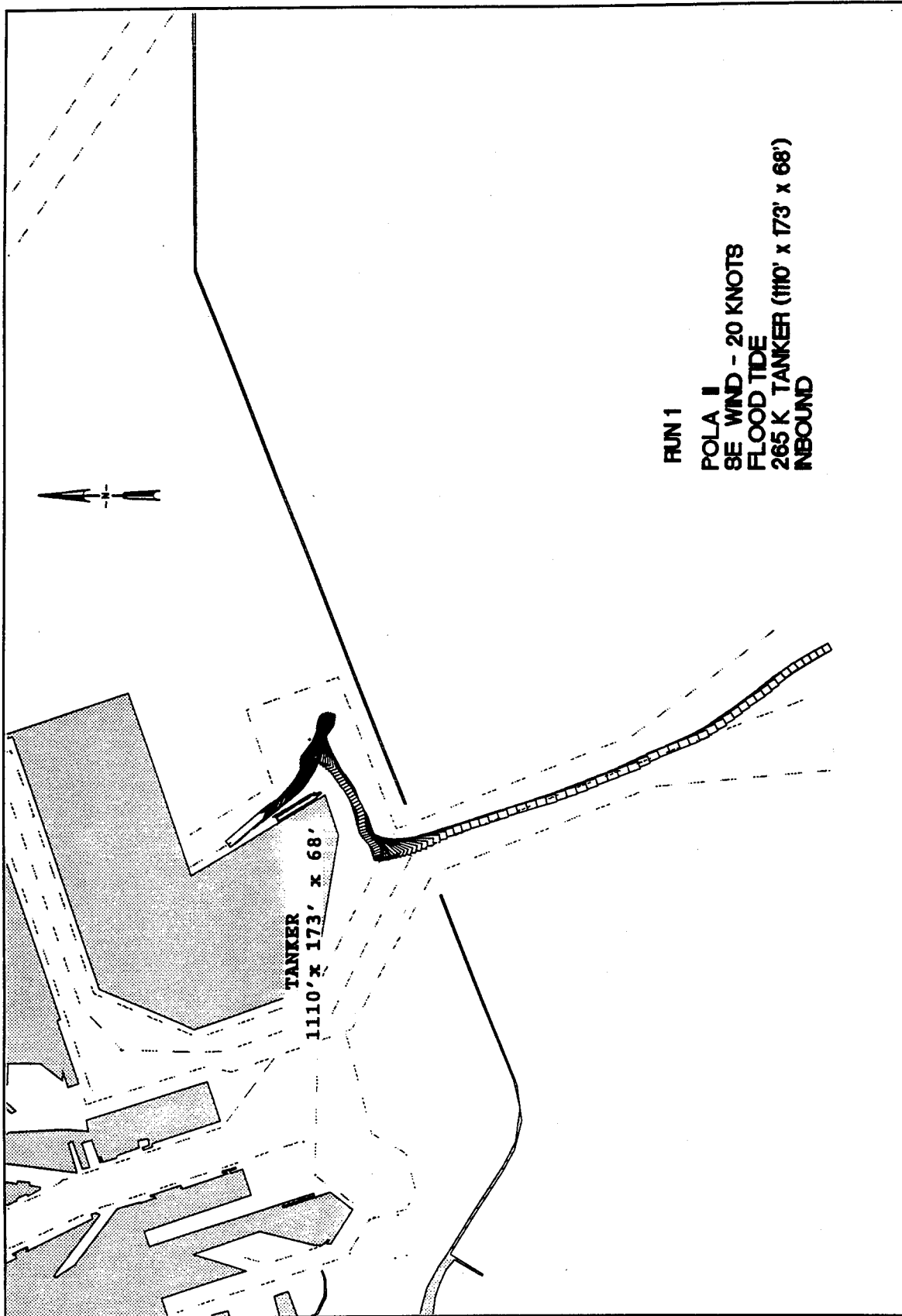

Plate 206



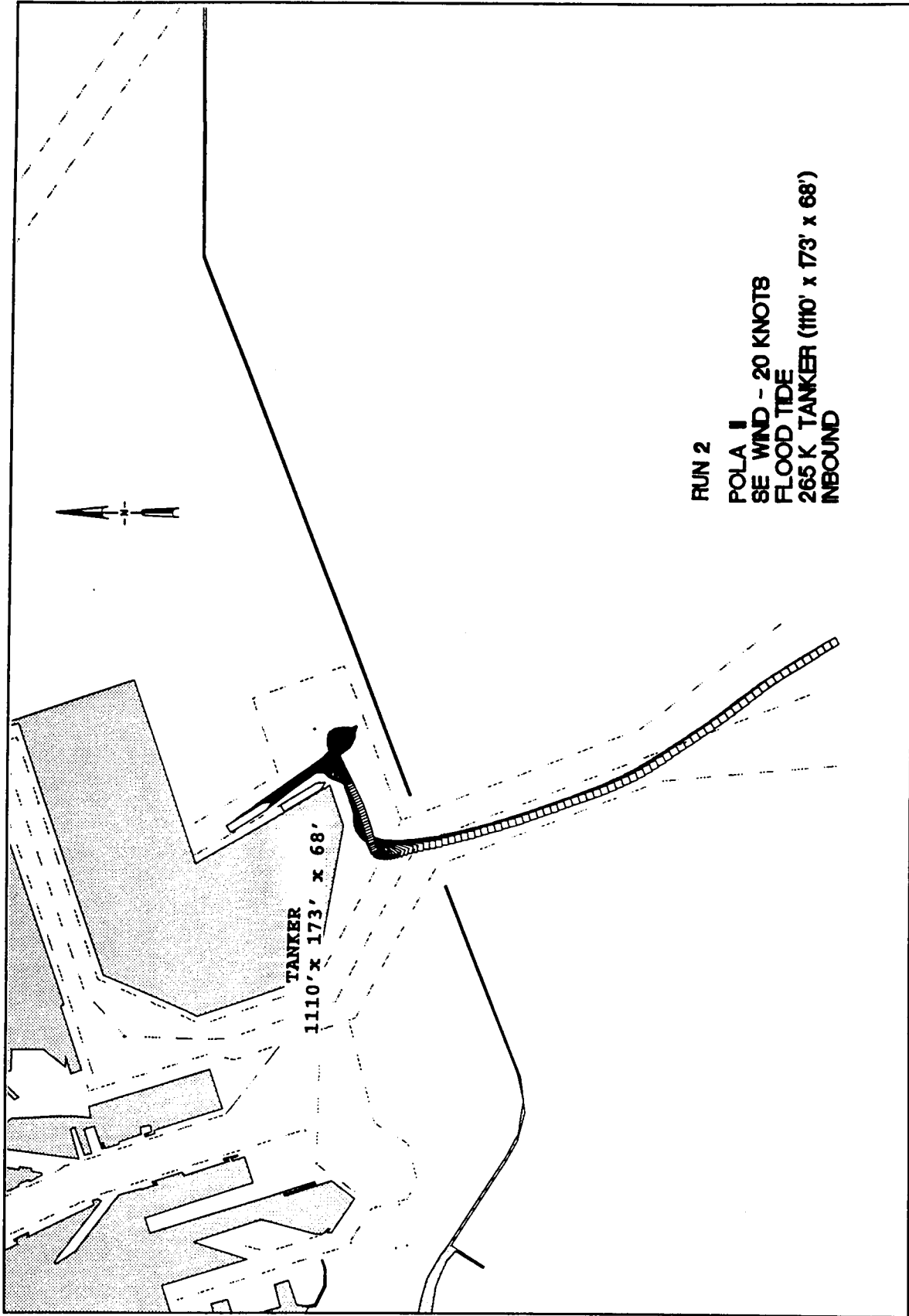
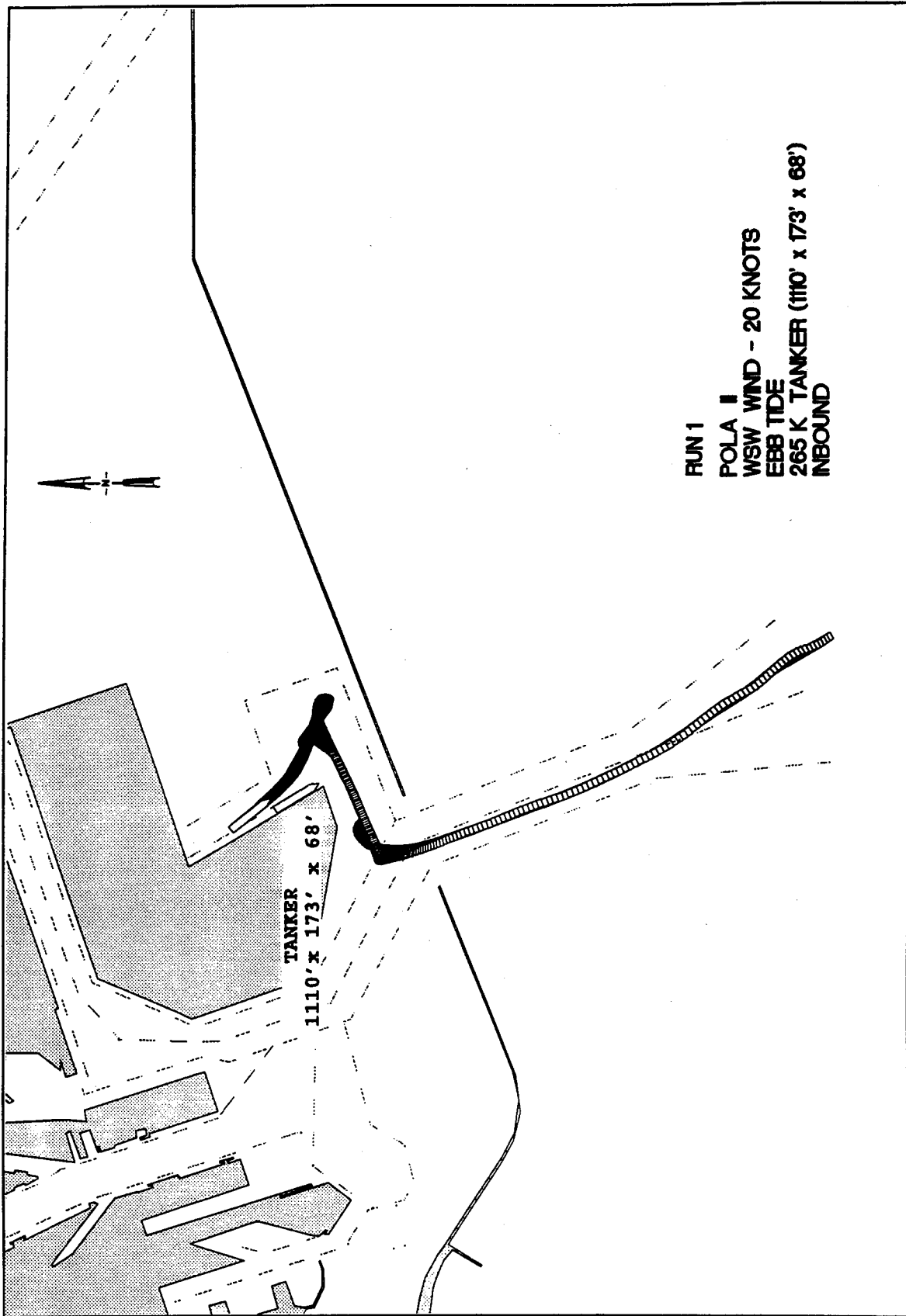
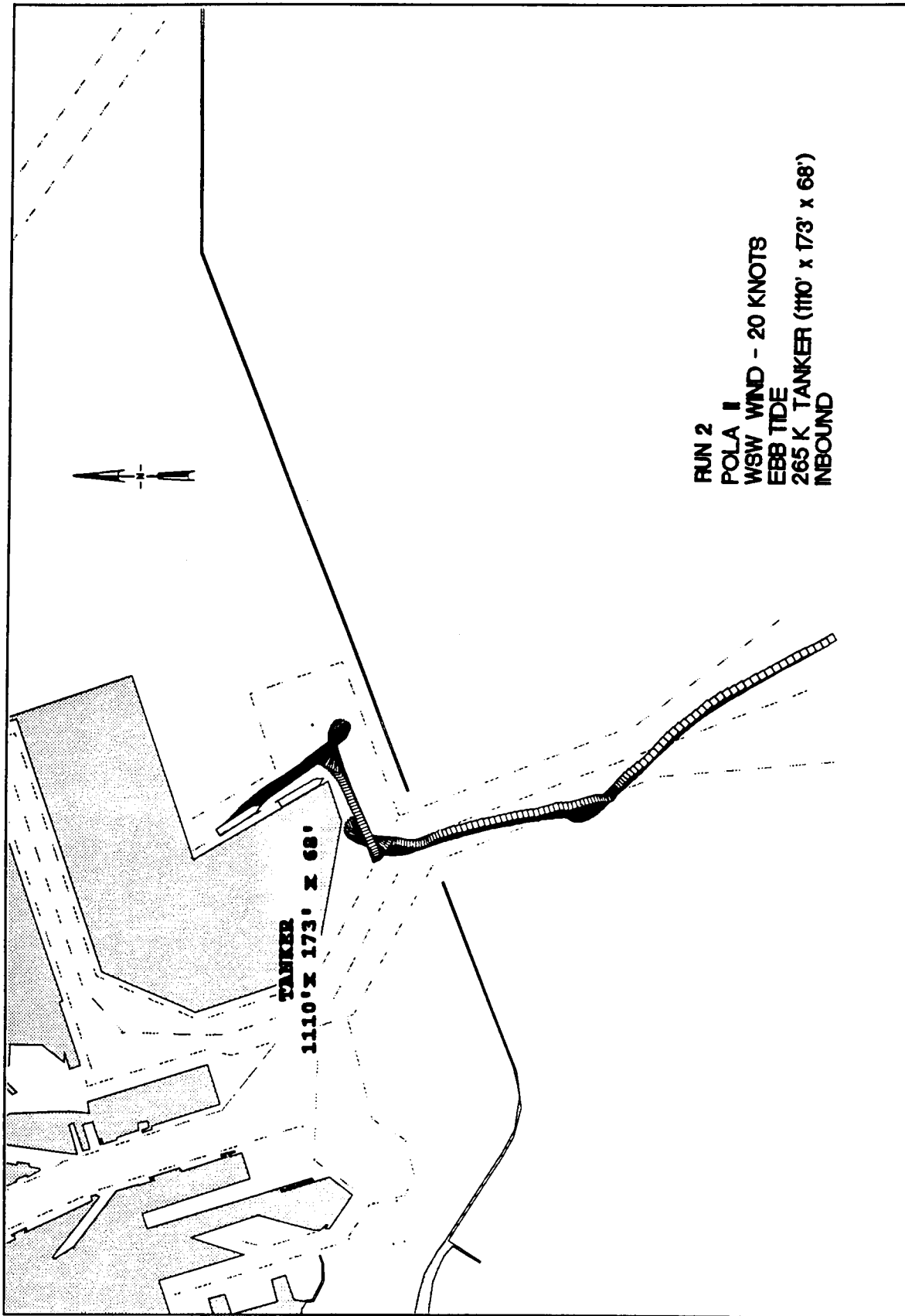

Plate 208



RUN 1  
POLA II  
WSW WIND - 20 KNOTS  
EBB TIDE  
265 K TANKER (1110' x 173' x 68')  
INBOUND



RUN 2  
POLA I  
WSW WIND - 20 KNOTS  
EBB TIDE  
265 K. TANKER (110' x 173' x 68')  
INBOUND

Plate 210

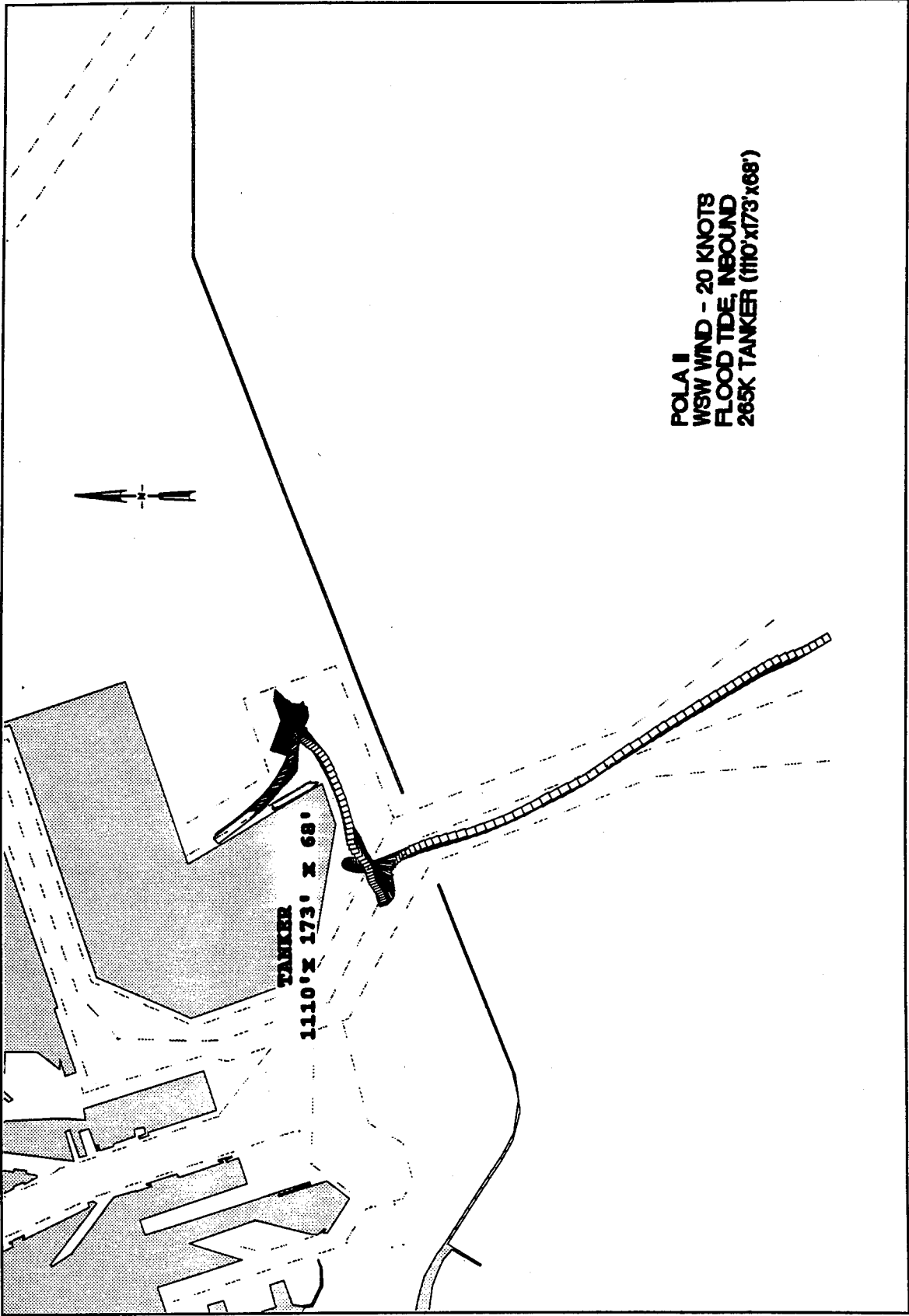

Plate 211

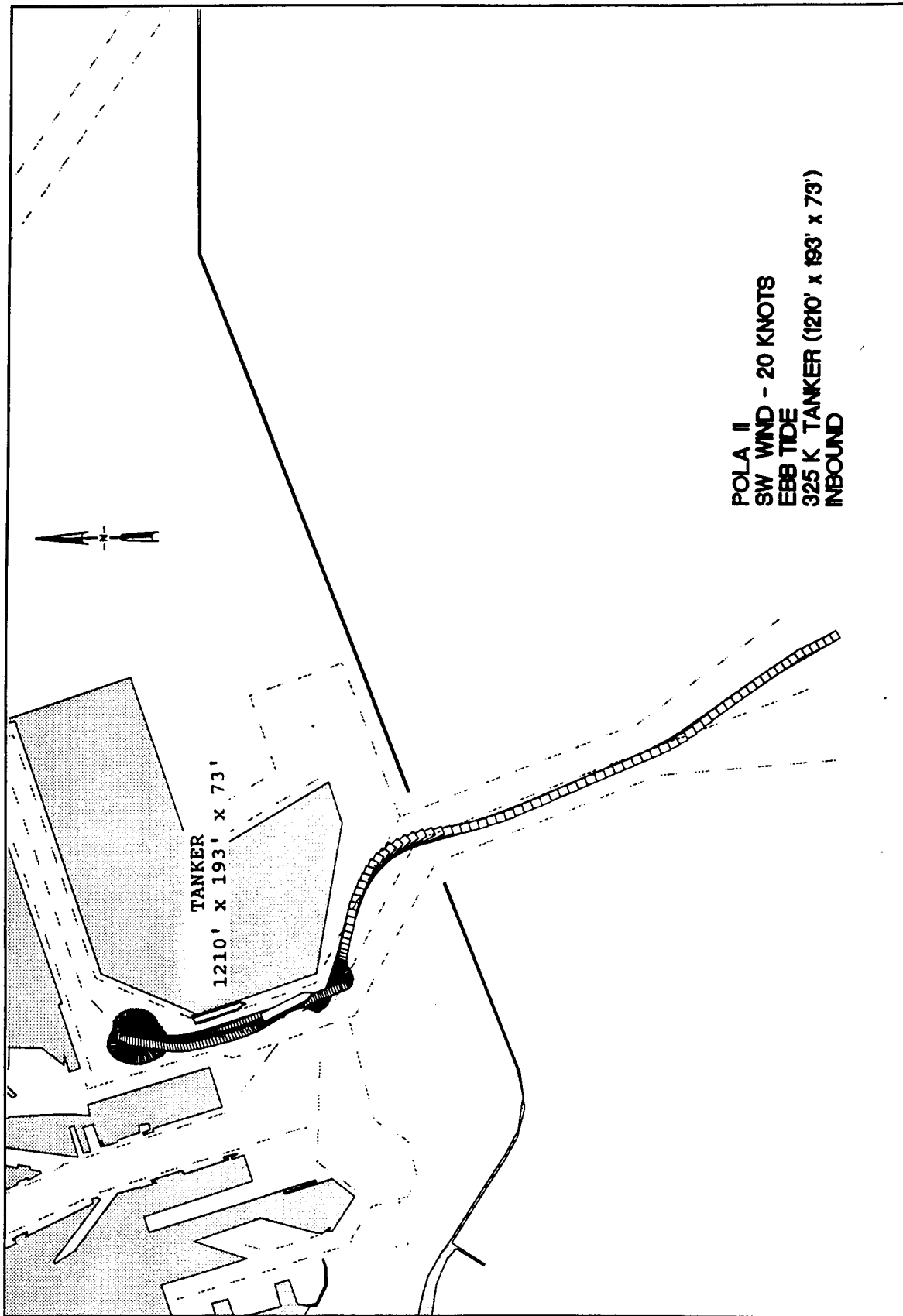
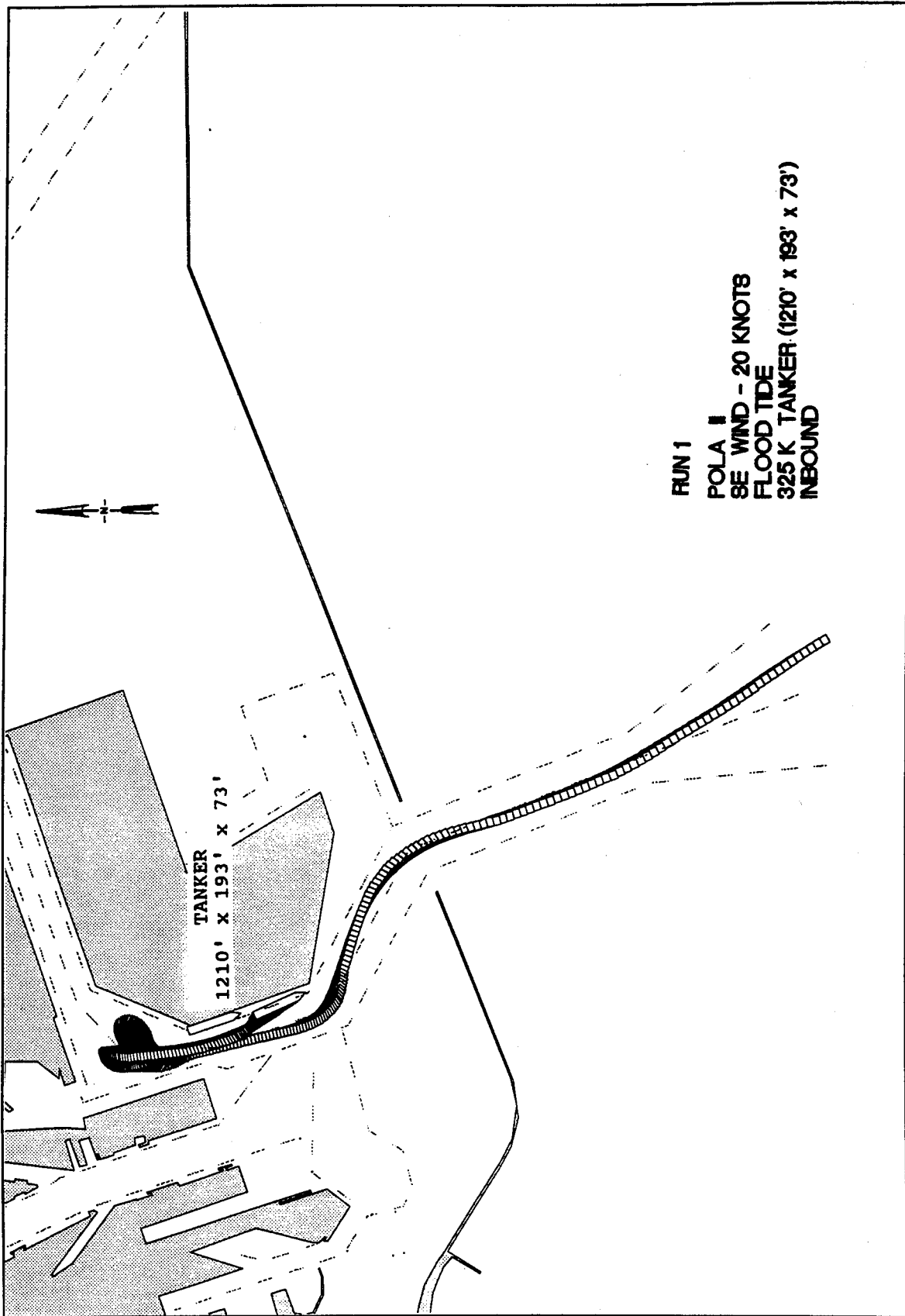
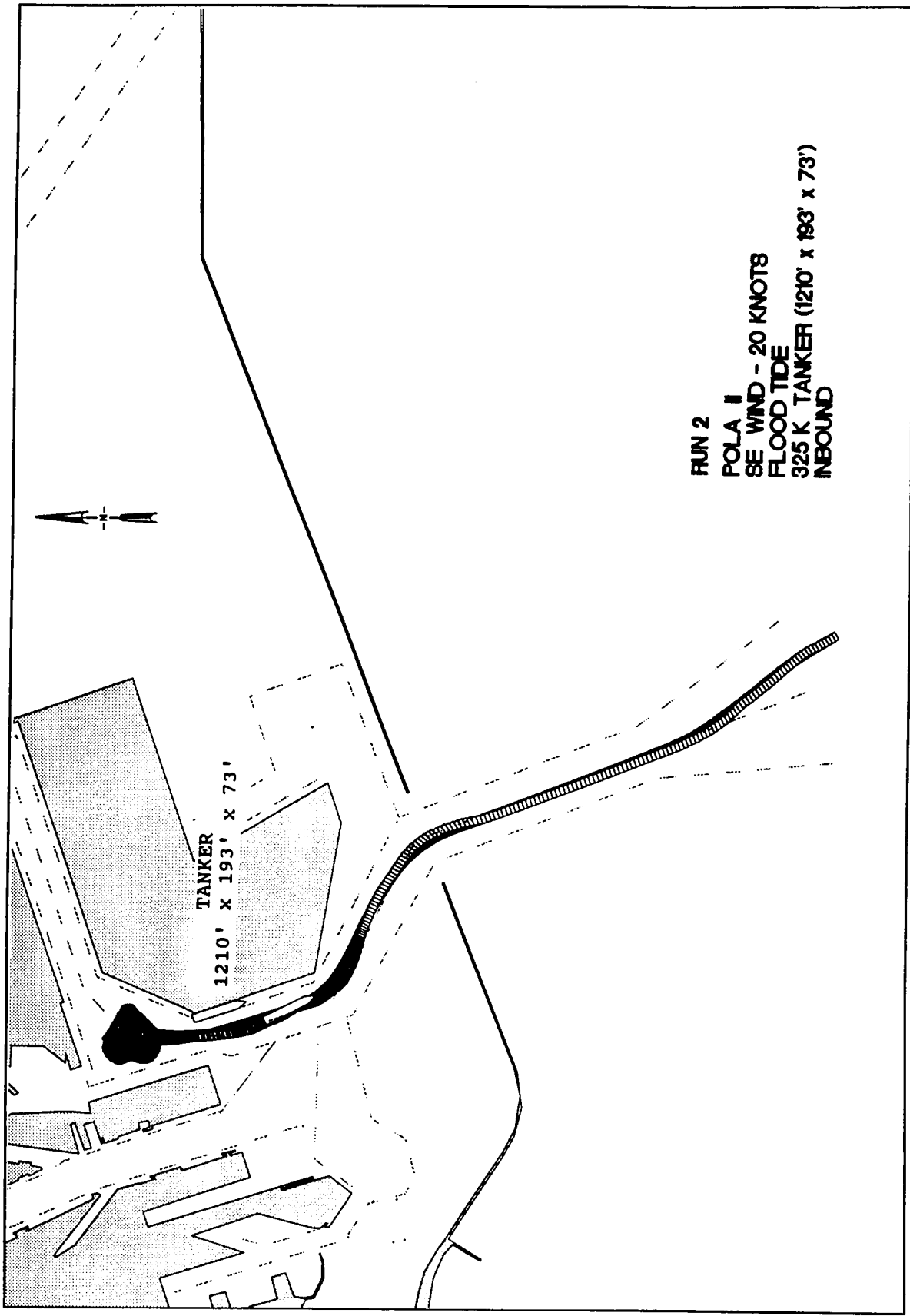

Plate 212





RUN 2  
POLA II  
SE WIND - 20 KNOTS  
FLOOD TIDE  
325 K TANKER (1210' x 193' x 73')  
INBOUND

Plate 214

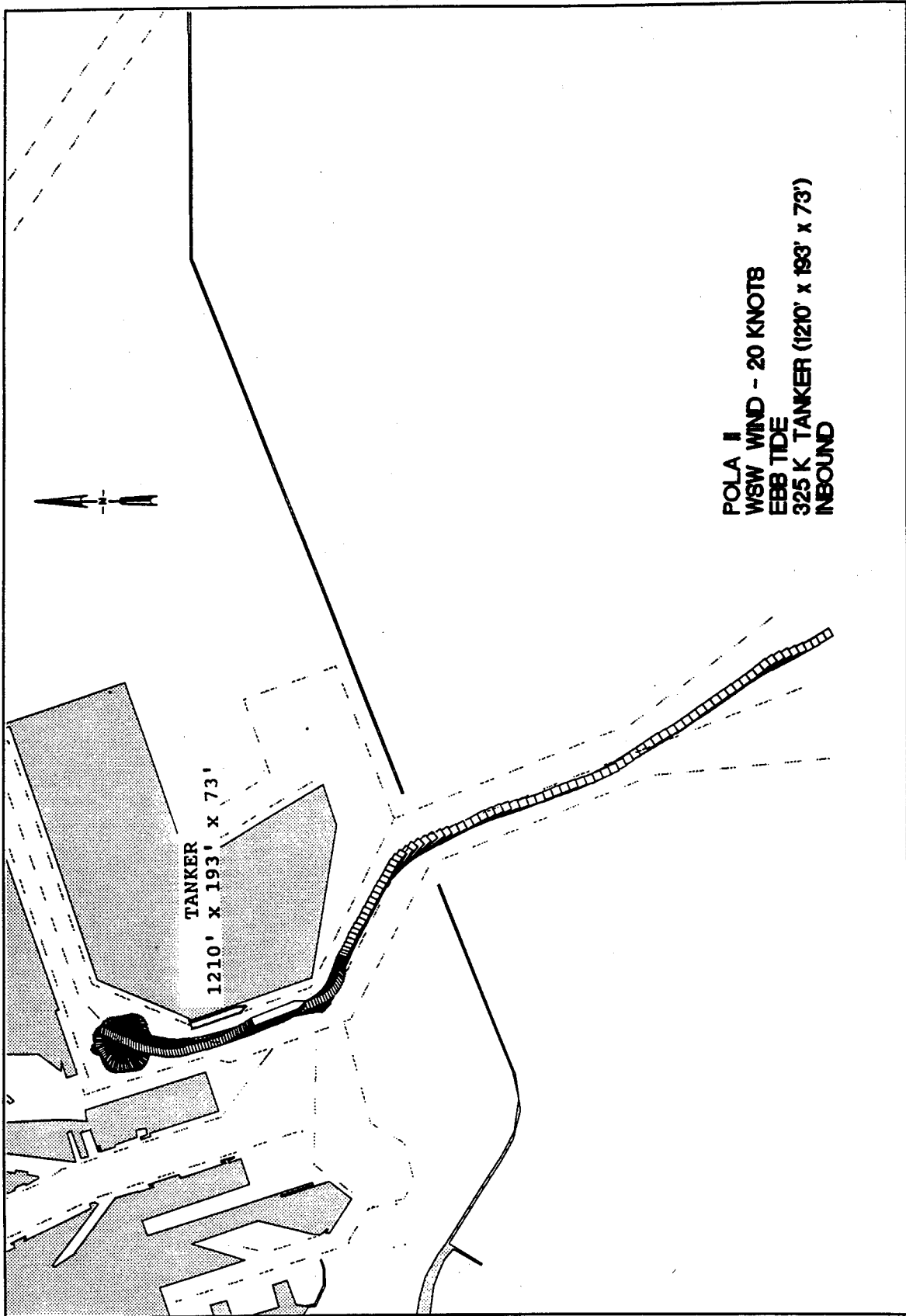

**POLA II**  
**WSW WIND - 20 KNOTS**  
**EBB TIDE**  
**325 K TANKER (1210' x 193' x 73')**  
**INBOUND**

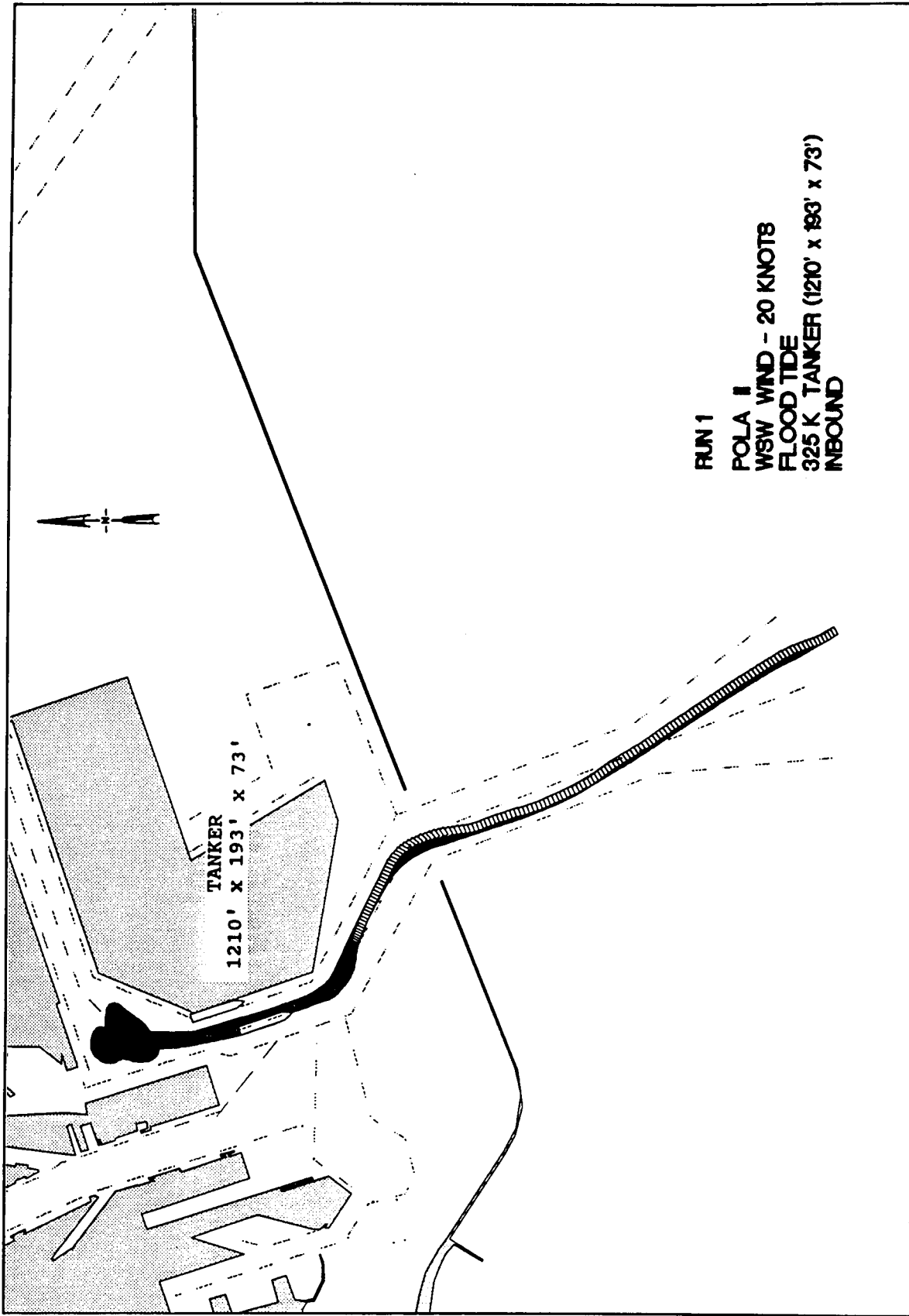

RUN 1  
POLA II  
WSW WIND - 20 KNOTS  
FLOOD TIDE  
325 K TANKER (1210' x 193' x 73')  
INBOUND

Plate 216

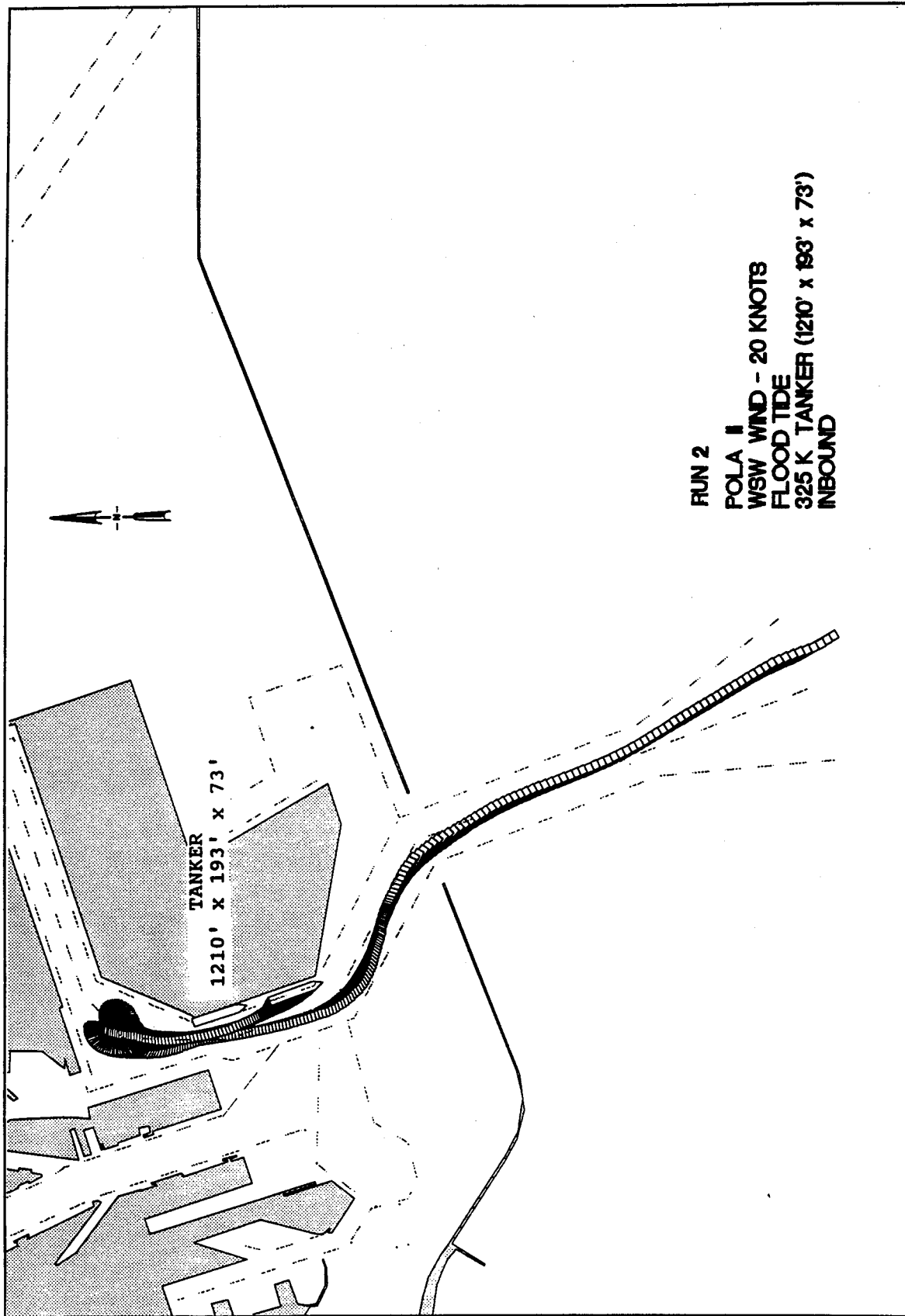

RUN 2  
POLA II  
WSW WIND - 20 KNOTS  
FLOOD TIDE  
325 K TANKER (1210' x 193' x 73')  
INBOUND

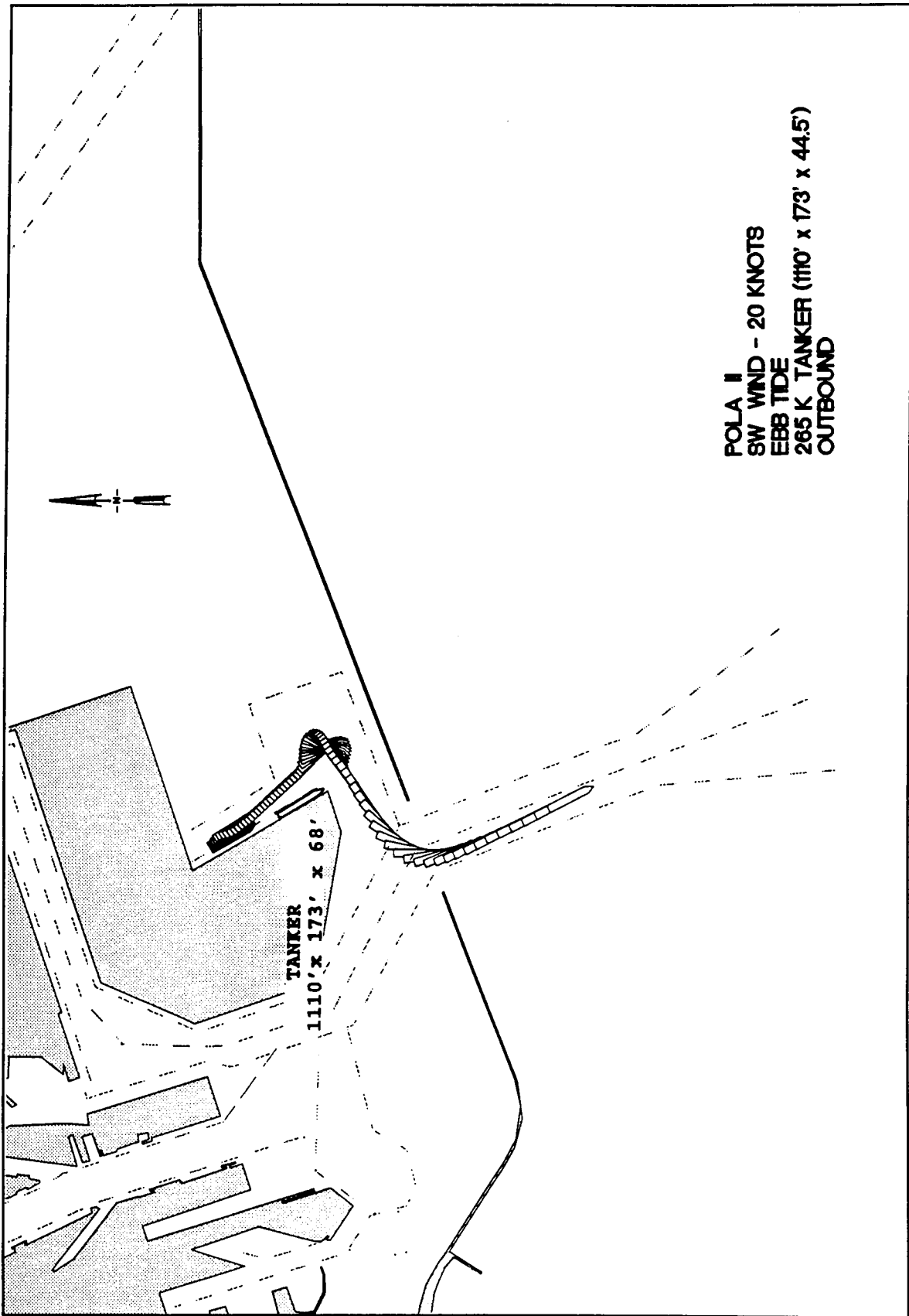

POLA II  
SW WIND - 20 KNOTS  
EBB TIDE  
265 K TANKER (1110' x 173' x 44.5)  
OUTBOUND

Plate 218

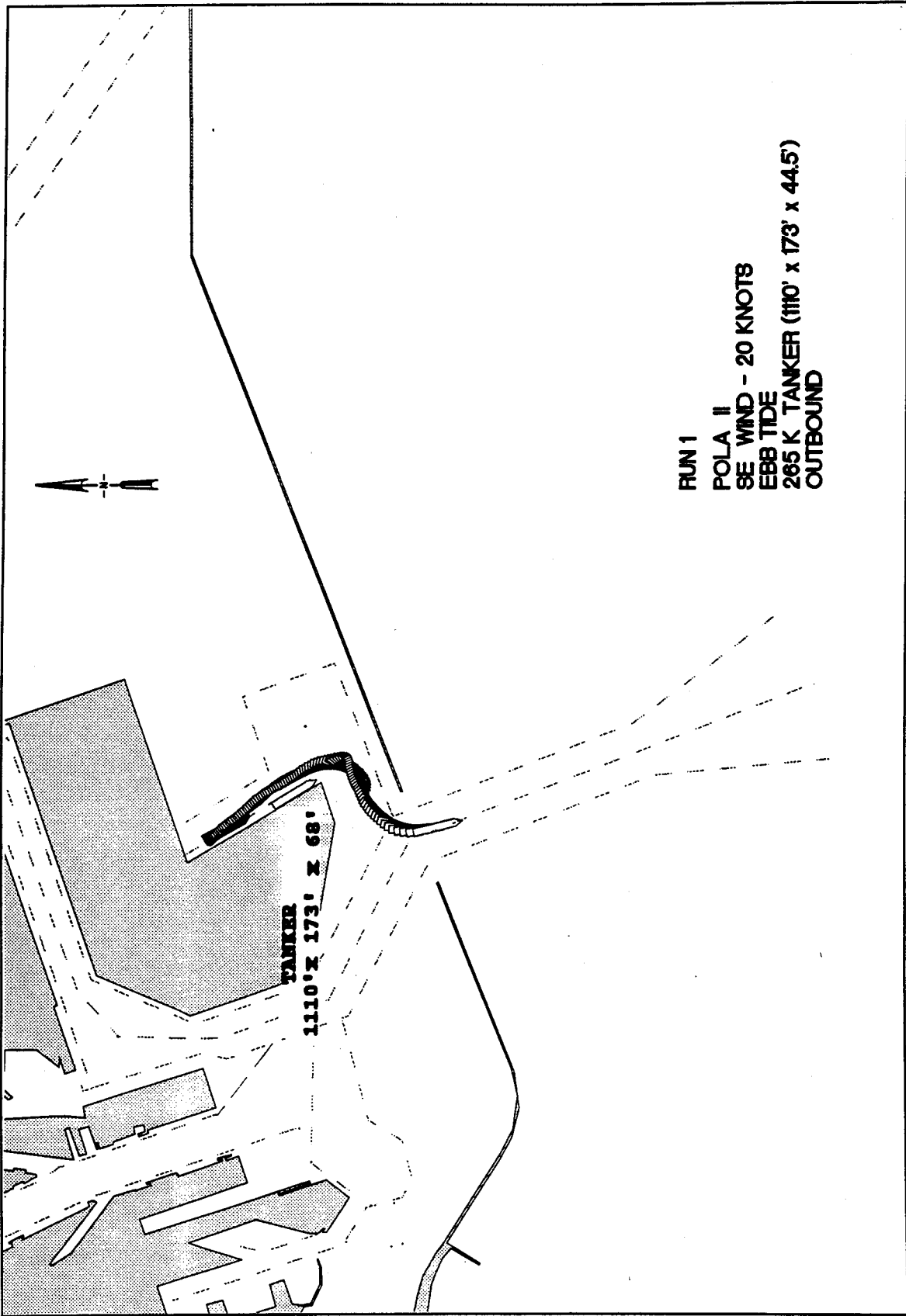

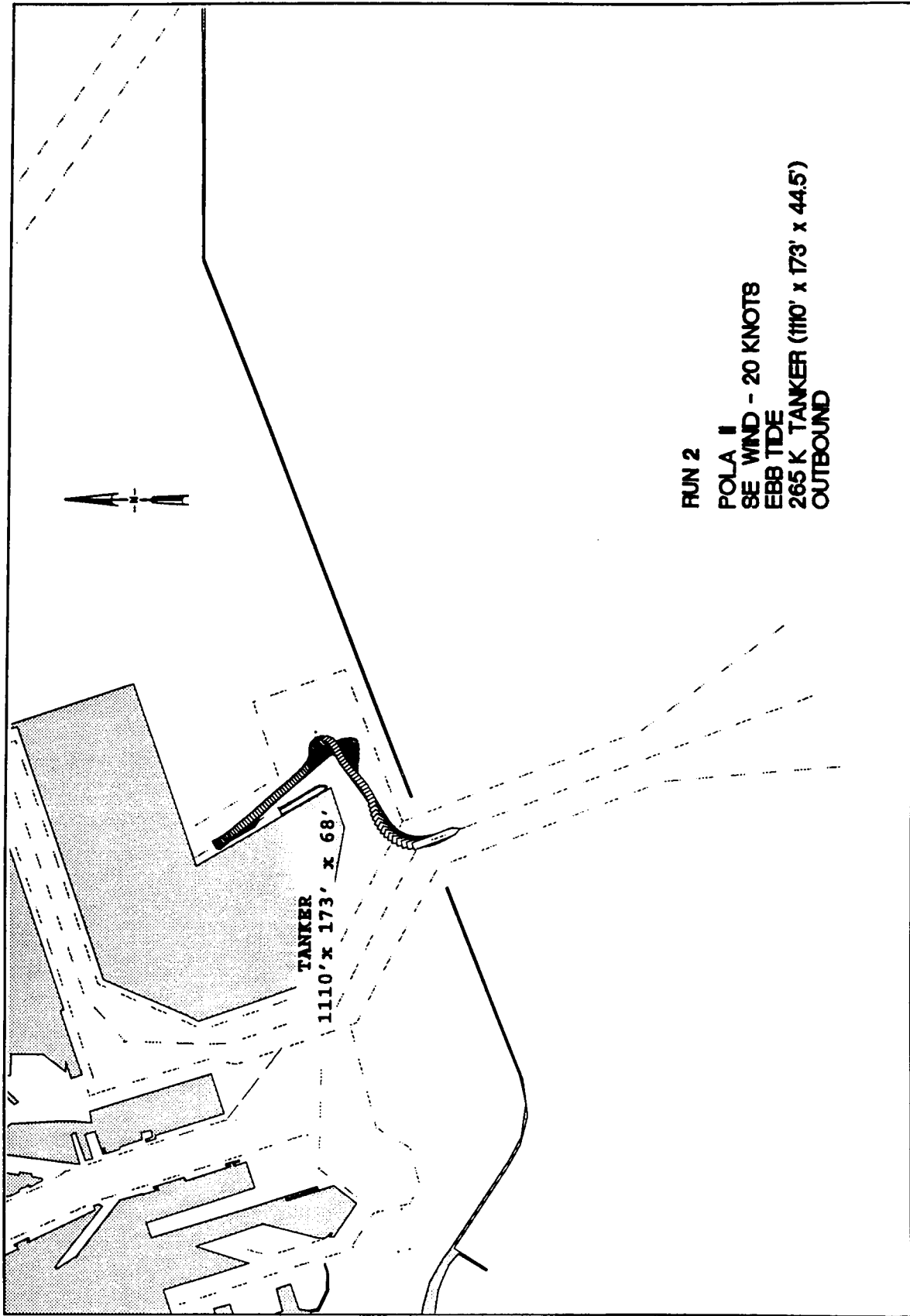
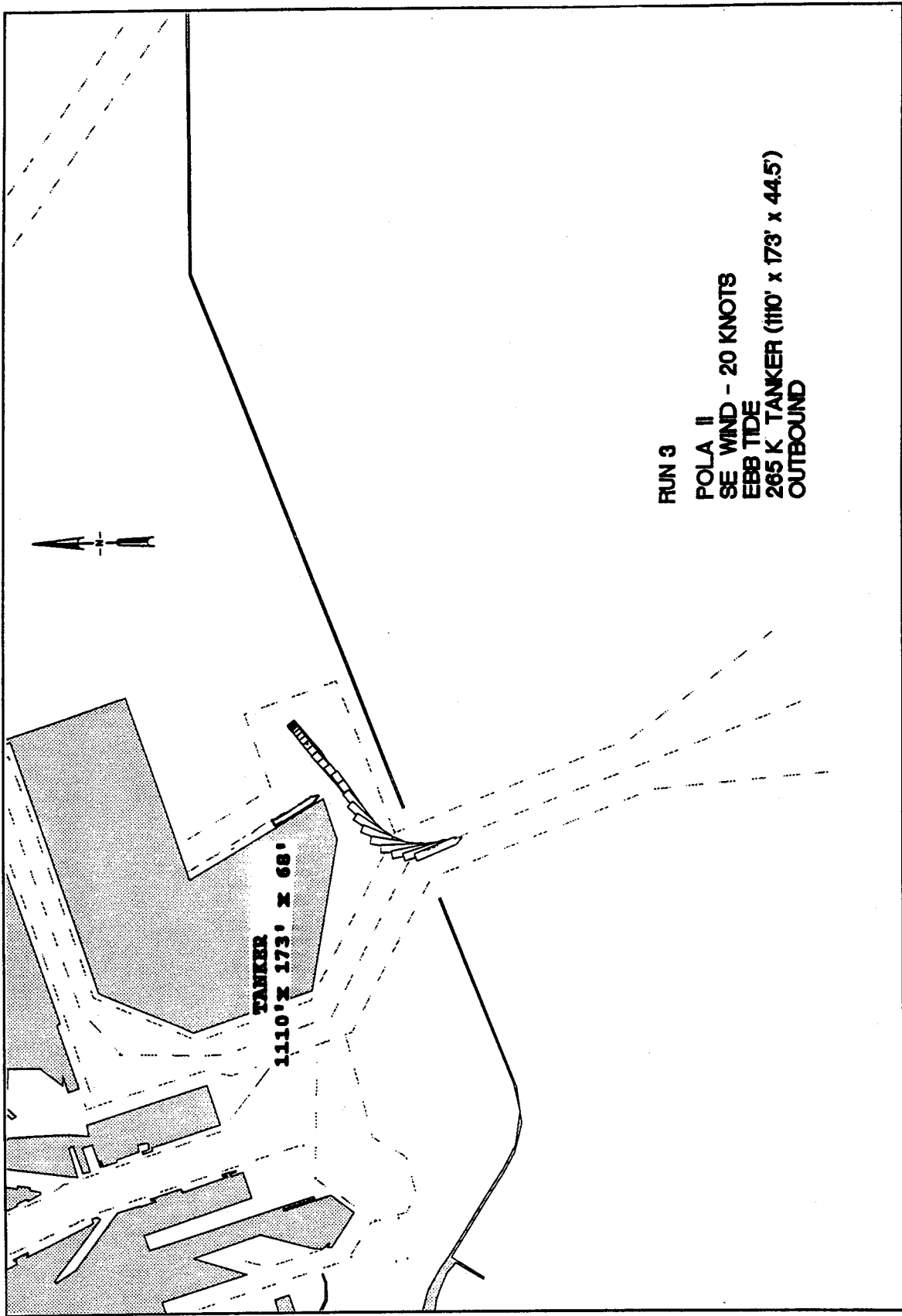

Plate 220



RUN 3  
POLA II  
SE WIND - 20 KNOTS  
EBB TIDE  
265 K TANKER (1110' x 173' x 44.5')  
OUTBOUND

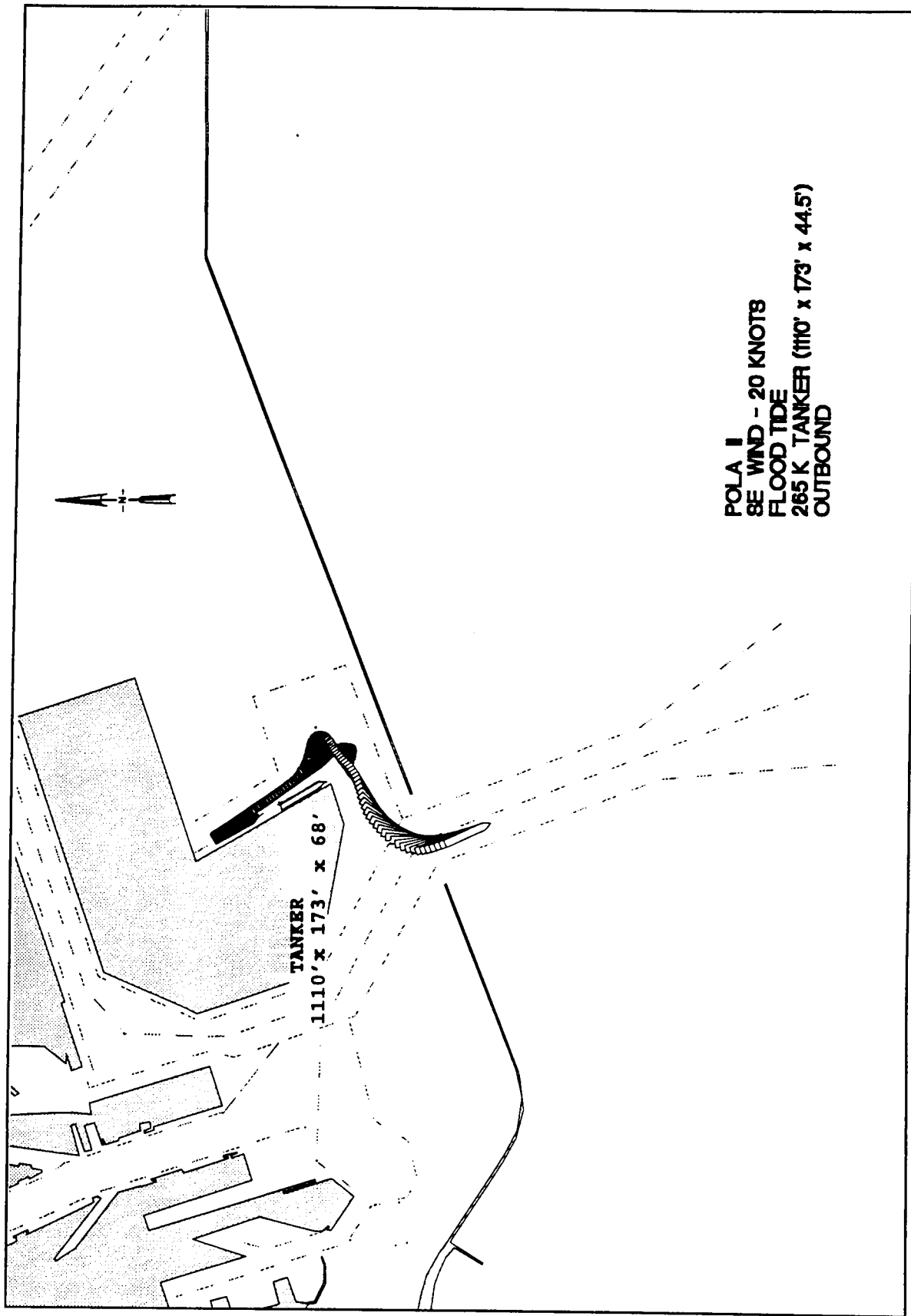
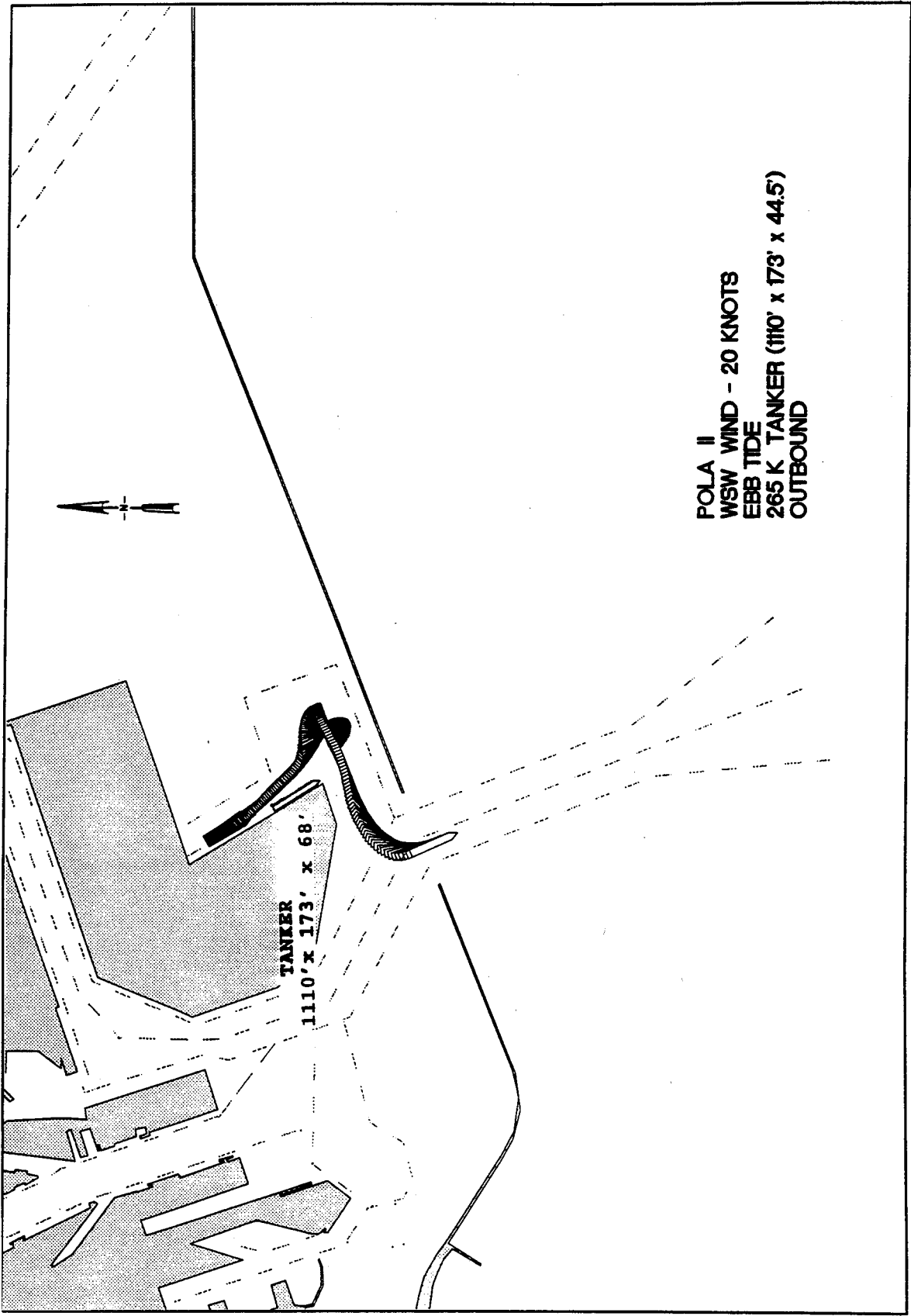
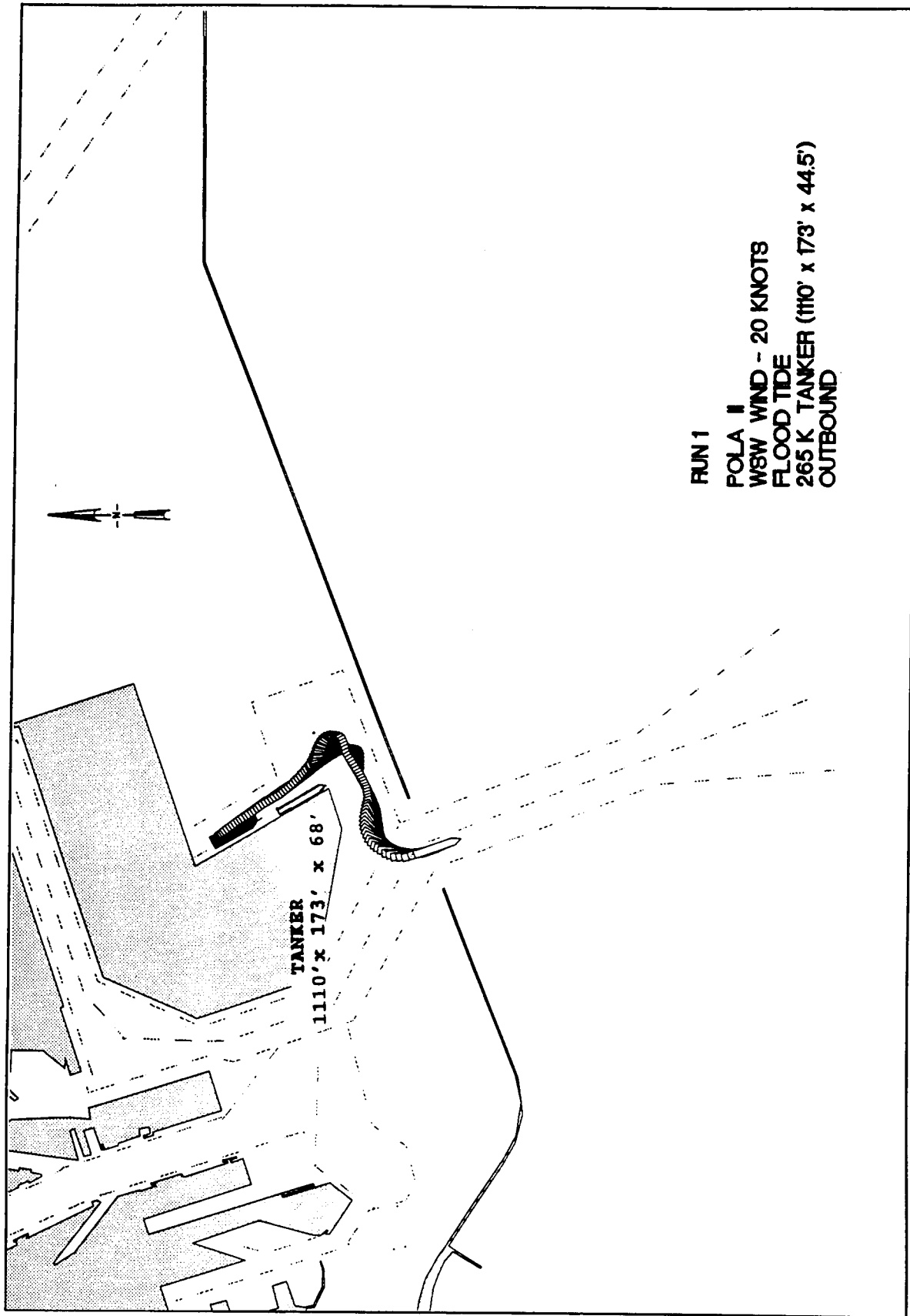

Plate 222



POLA II  
WSW WIND - 20 KNOTS  
EBB TIDE  
265 K TANKER (110' x 173' x 44.5')  
OUTBOUND

TANKER  
1110' x 173' x 68'



RUN 1  
POLA II  
WSW WIND - 20 KNOTS  
FLOOD TIDE  
265 K TANKER (1110' x 173' x 44.5')  
OUTBOUND

Plate 224

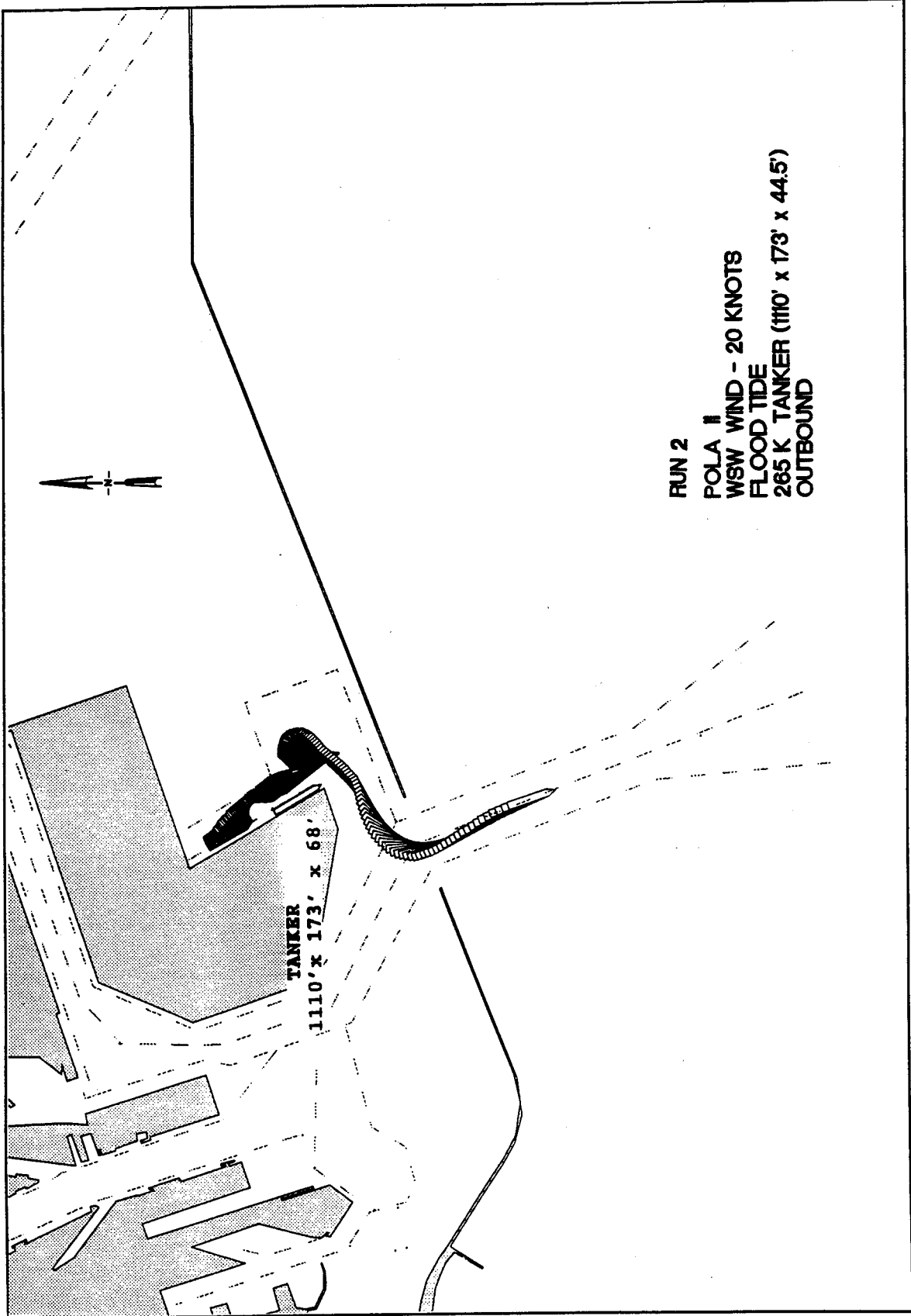

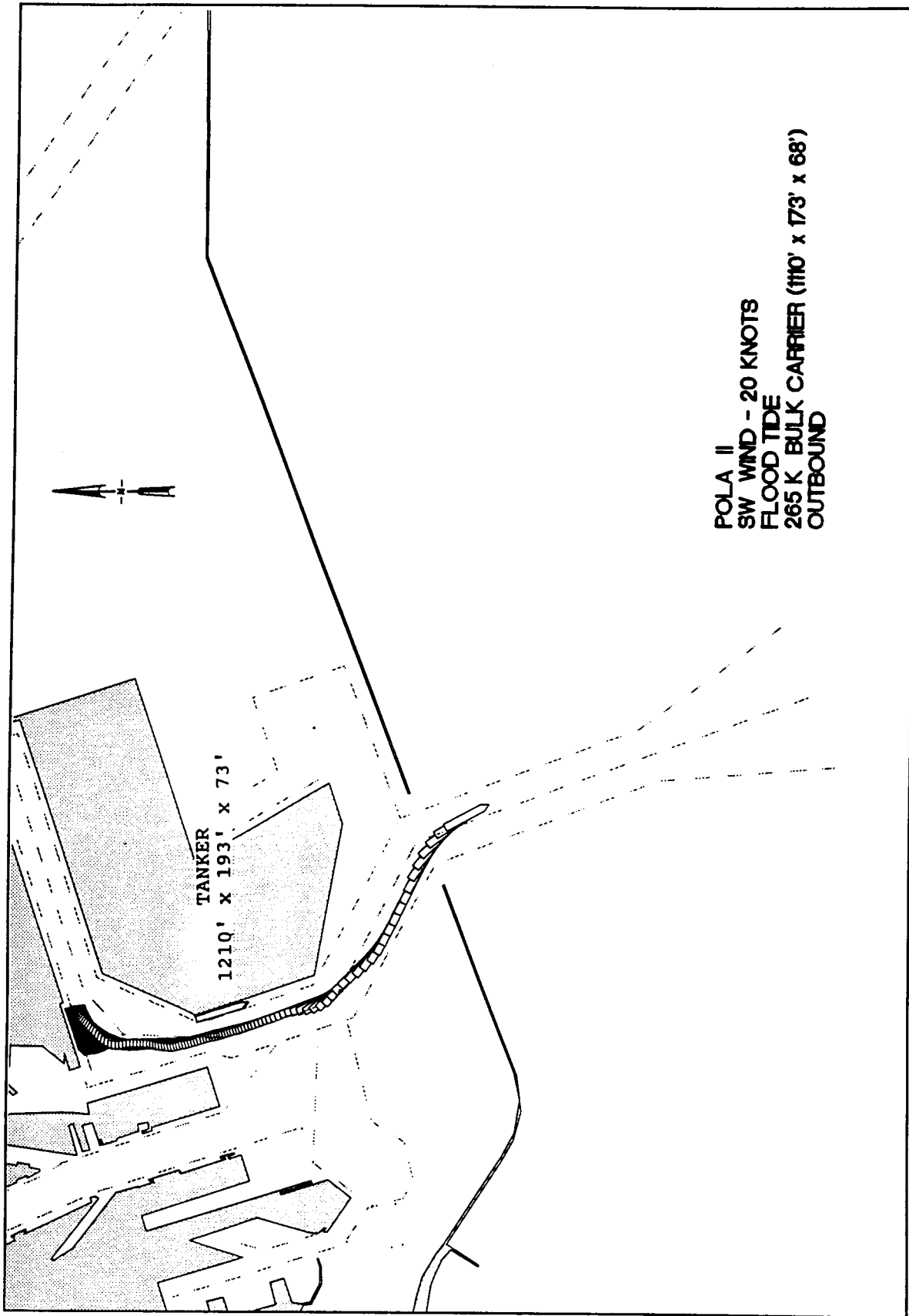
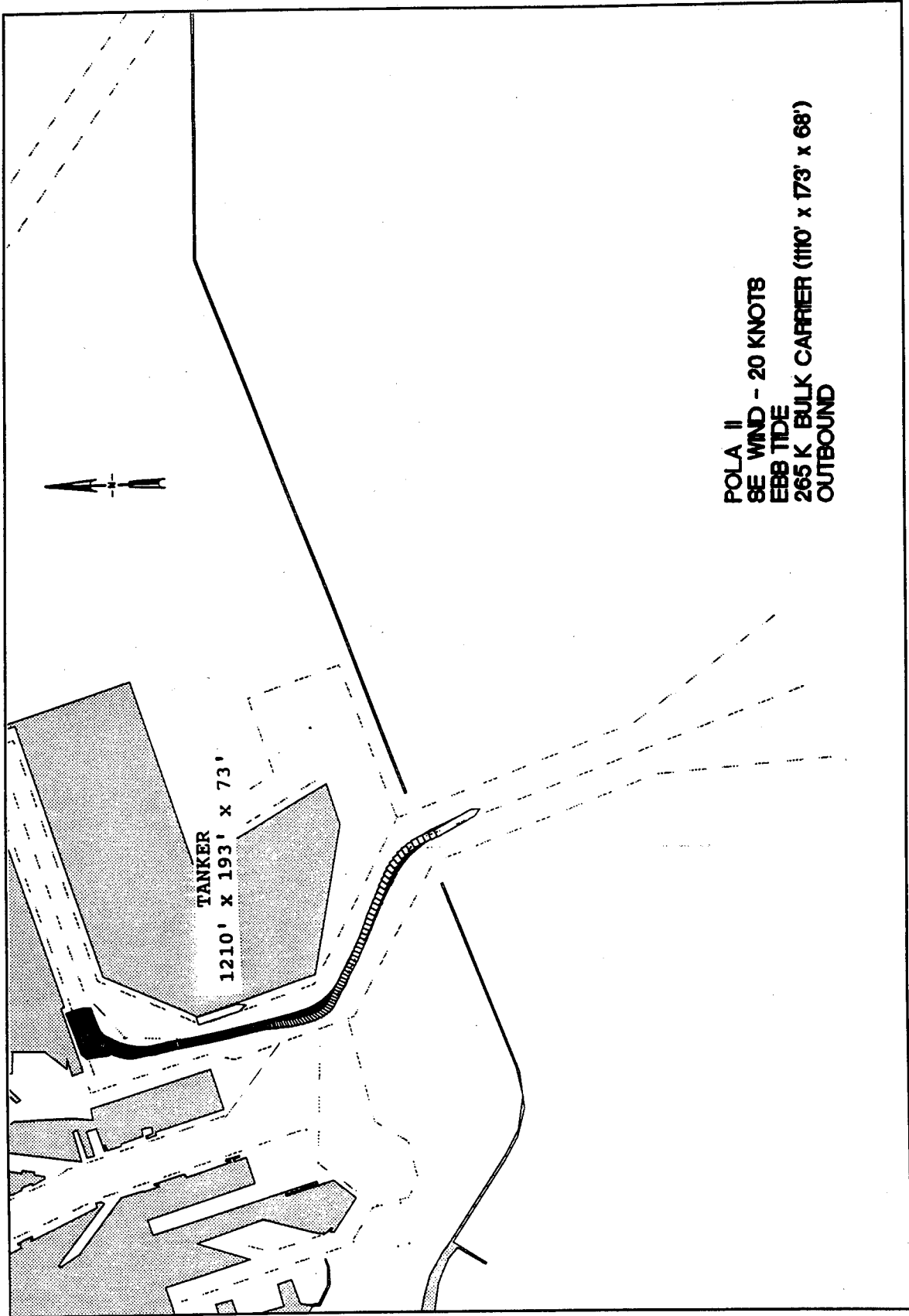

Plate 226



POLA II  
SE WIND - 20 KNOTS  
EBB TIDE  
265 K BULK CARRIER (1110' x 173' x 68')  
OUTBOUND

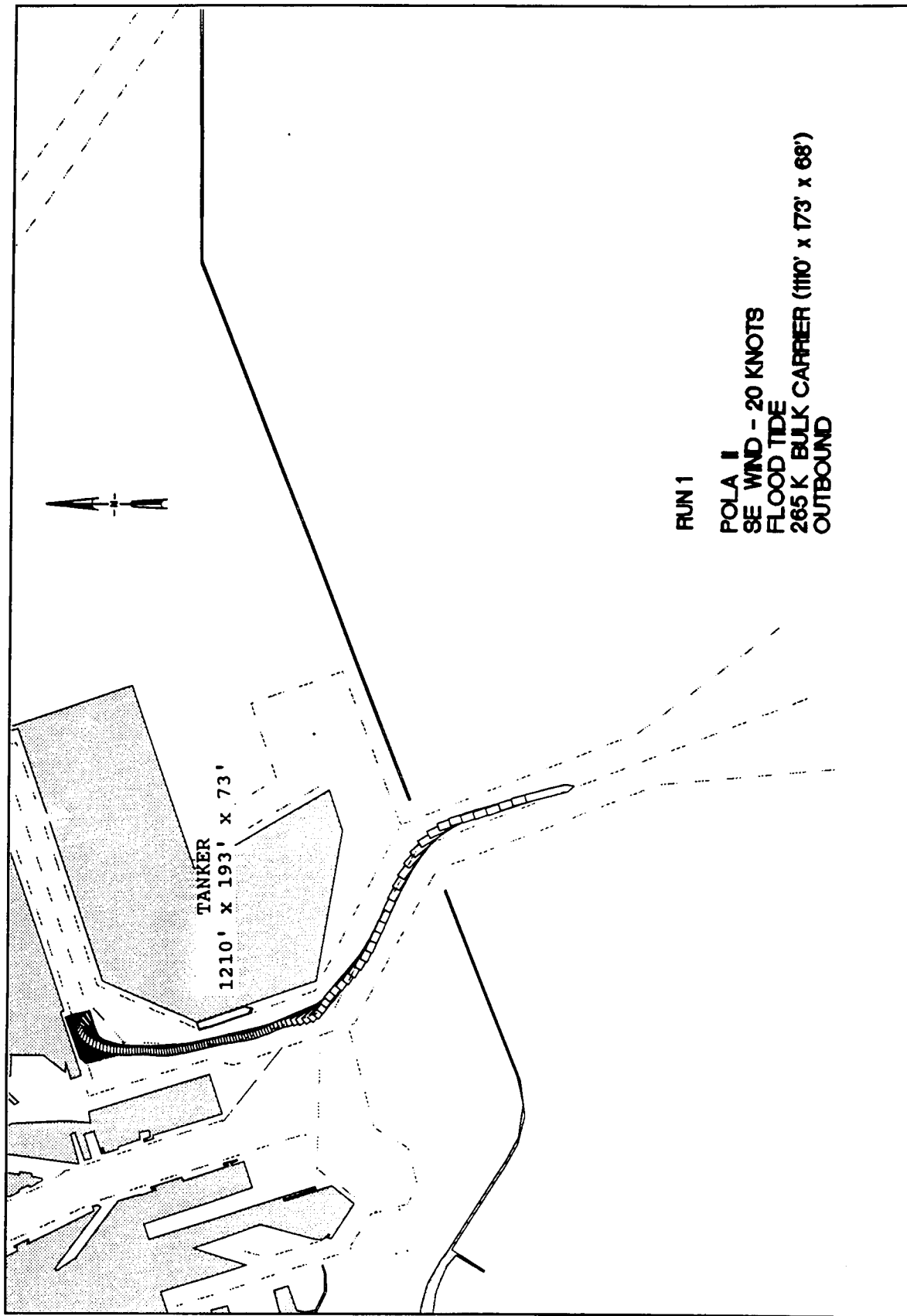
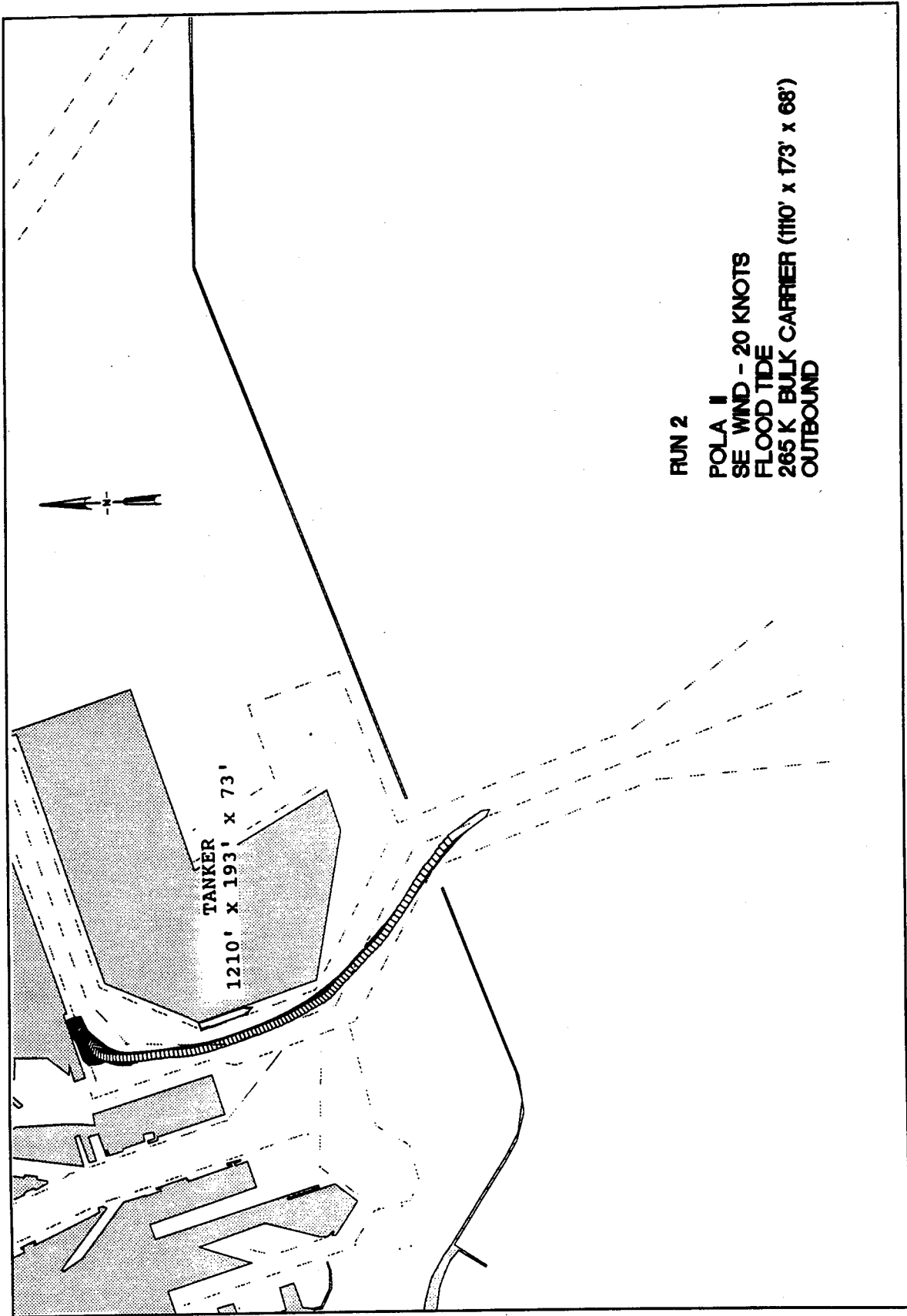

Plate 228



RUN 2  
POLA II  
SE WIND - 20 KNOTS  
FLOOD TIDE  
265 K BULK CARRIER (110' x 173' x 68')  
OUTBOUND

TANKER  
1210' x 193' x 73'

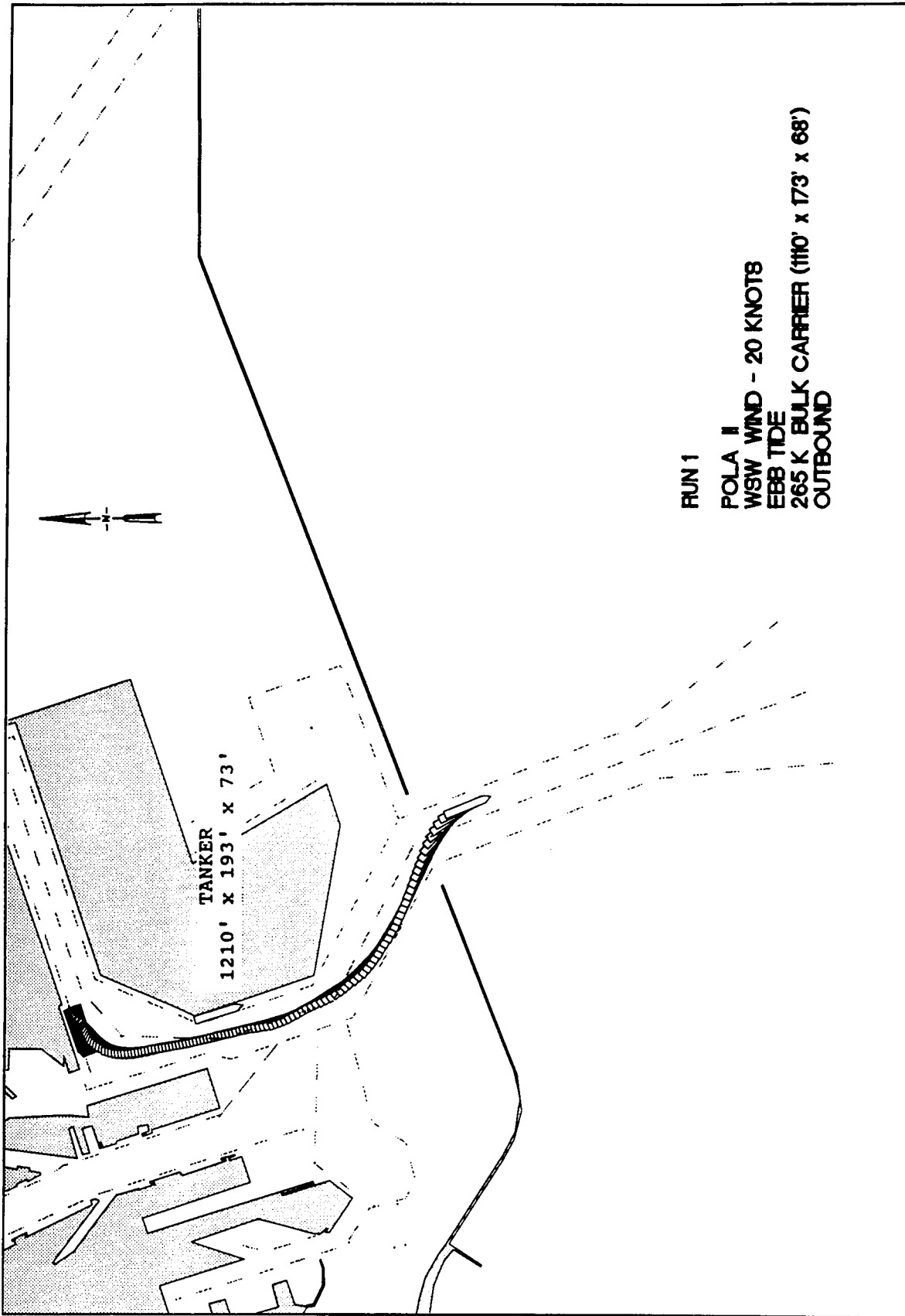
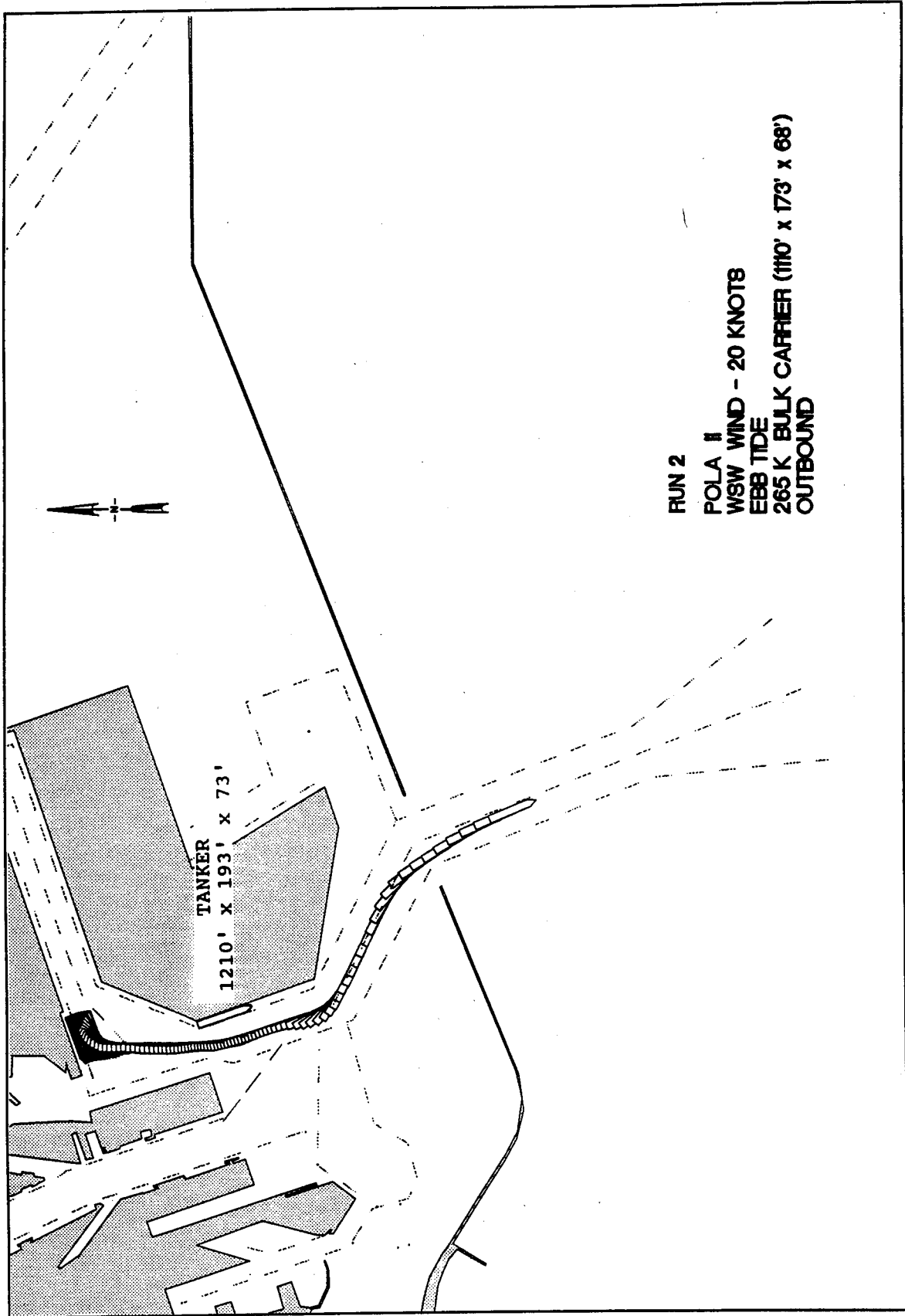

Plate 230



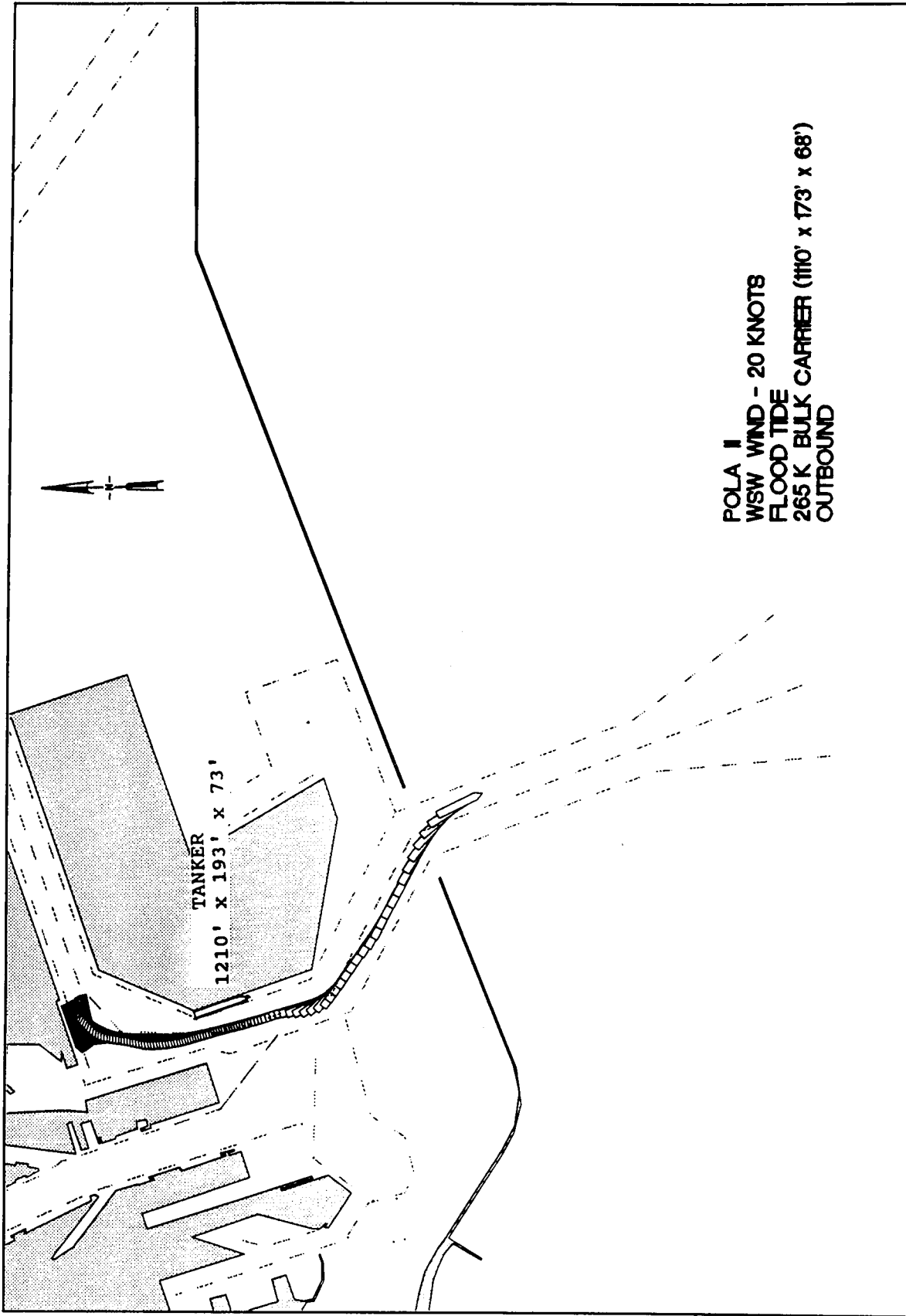
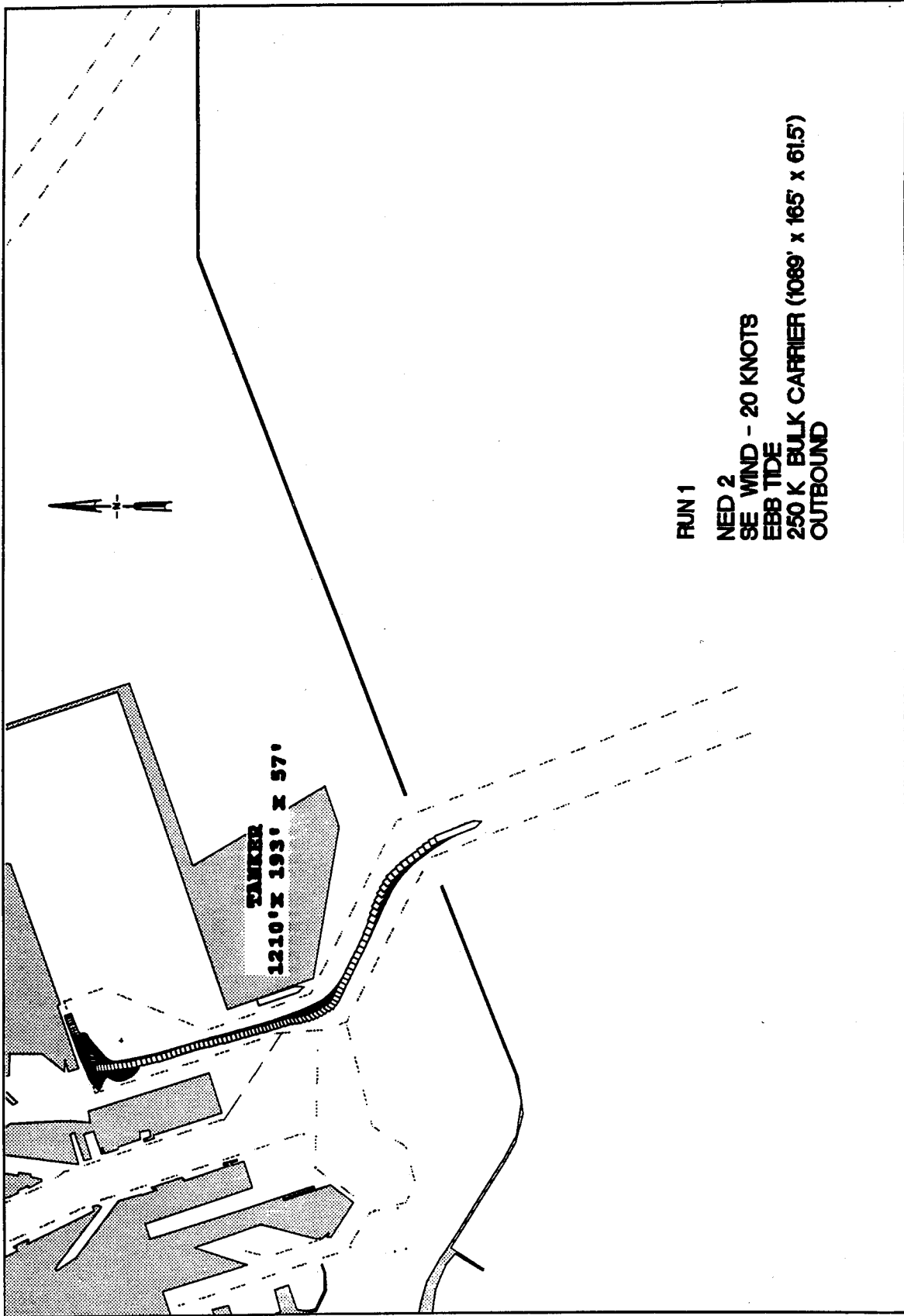

Plate 232



RUN 1  
NED 2  
SE WIND - 20 KNOTS  
EBB TIDE  
250 K BULK CARRIER (1089' x 165' x 61.5')  
OUTBOUND

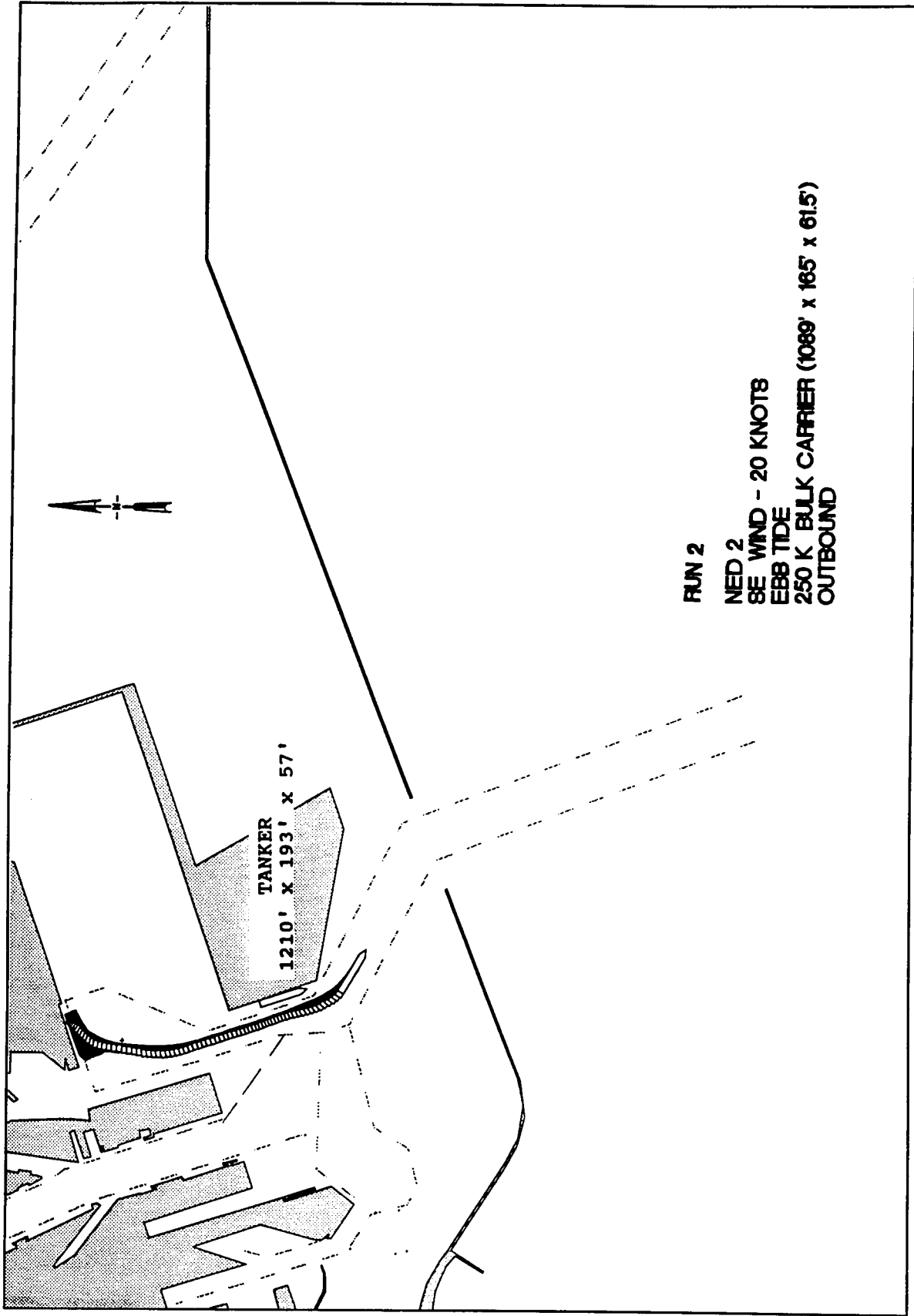
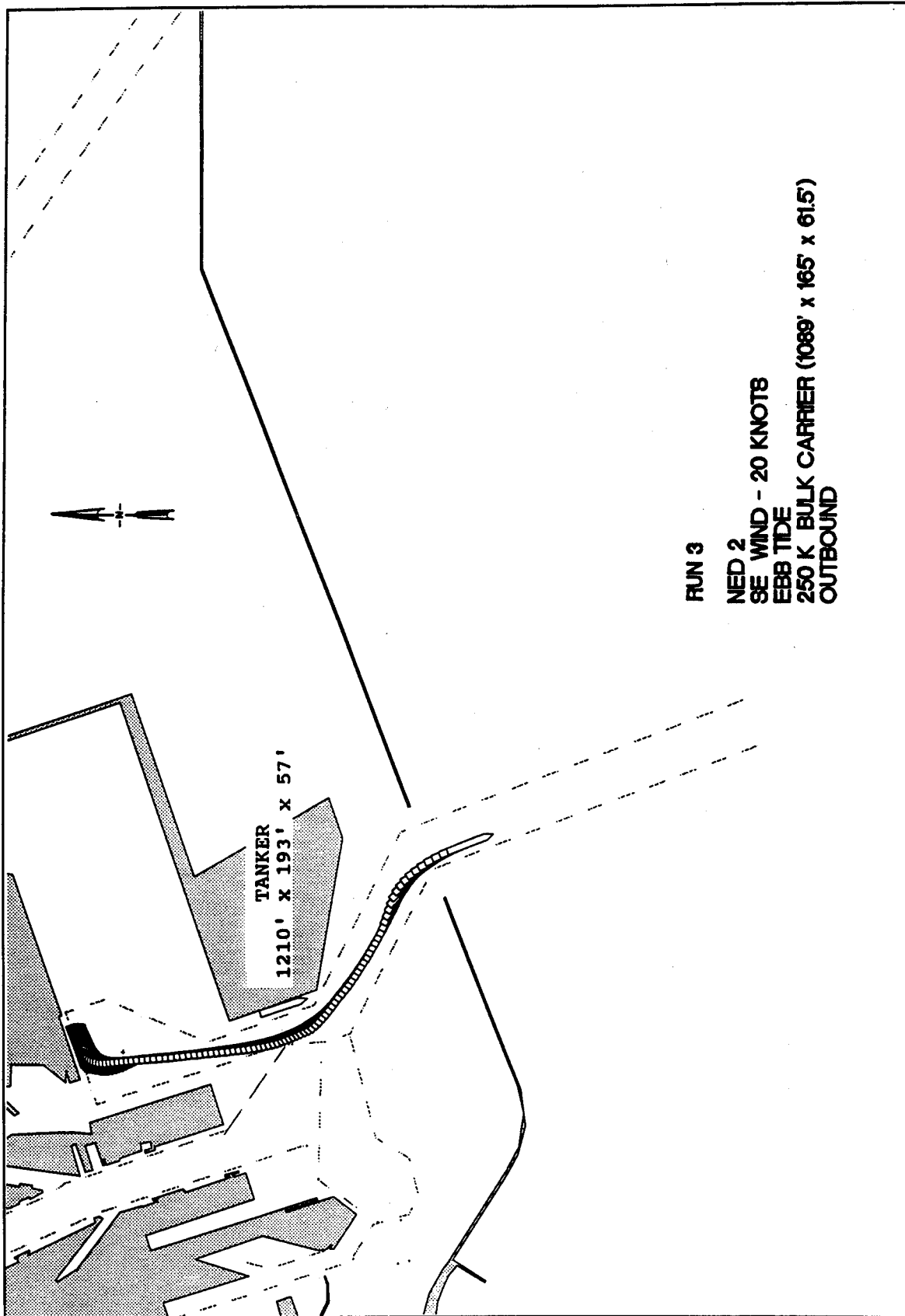
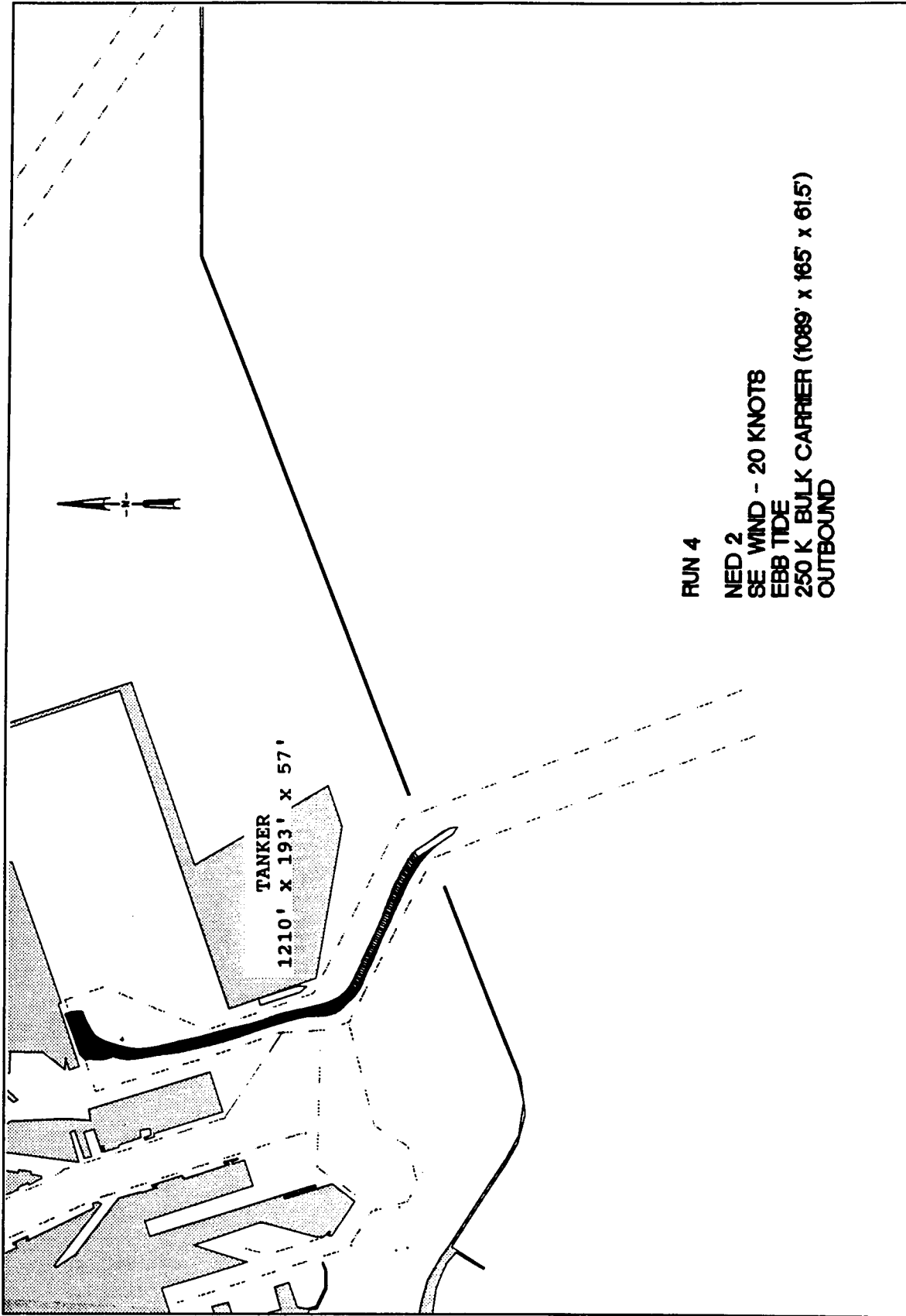

Plate 234





RUN 4  
NED 2  
SE WIND - 20 KNOTS  
EBB TIDE  
250 K BULK CARRIER (1089' x 165' x 61.5')  
OUTBOUND

TANKER  
1210' x 193' x 57'

Plate 236

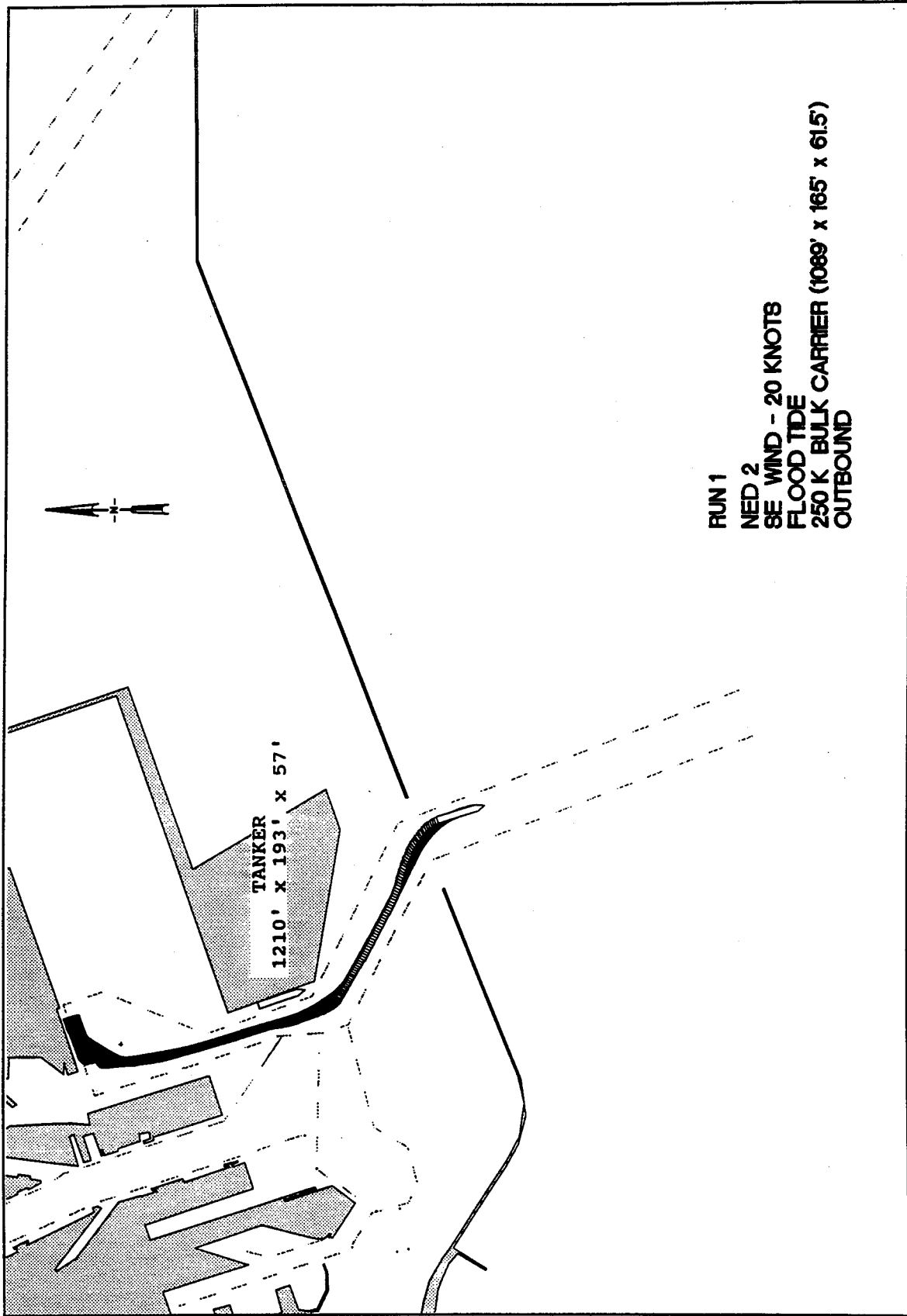

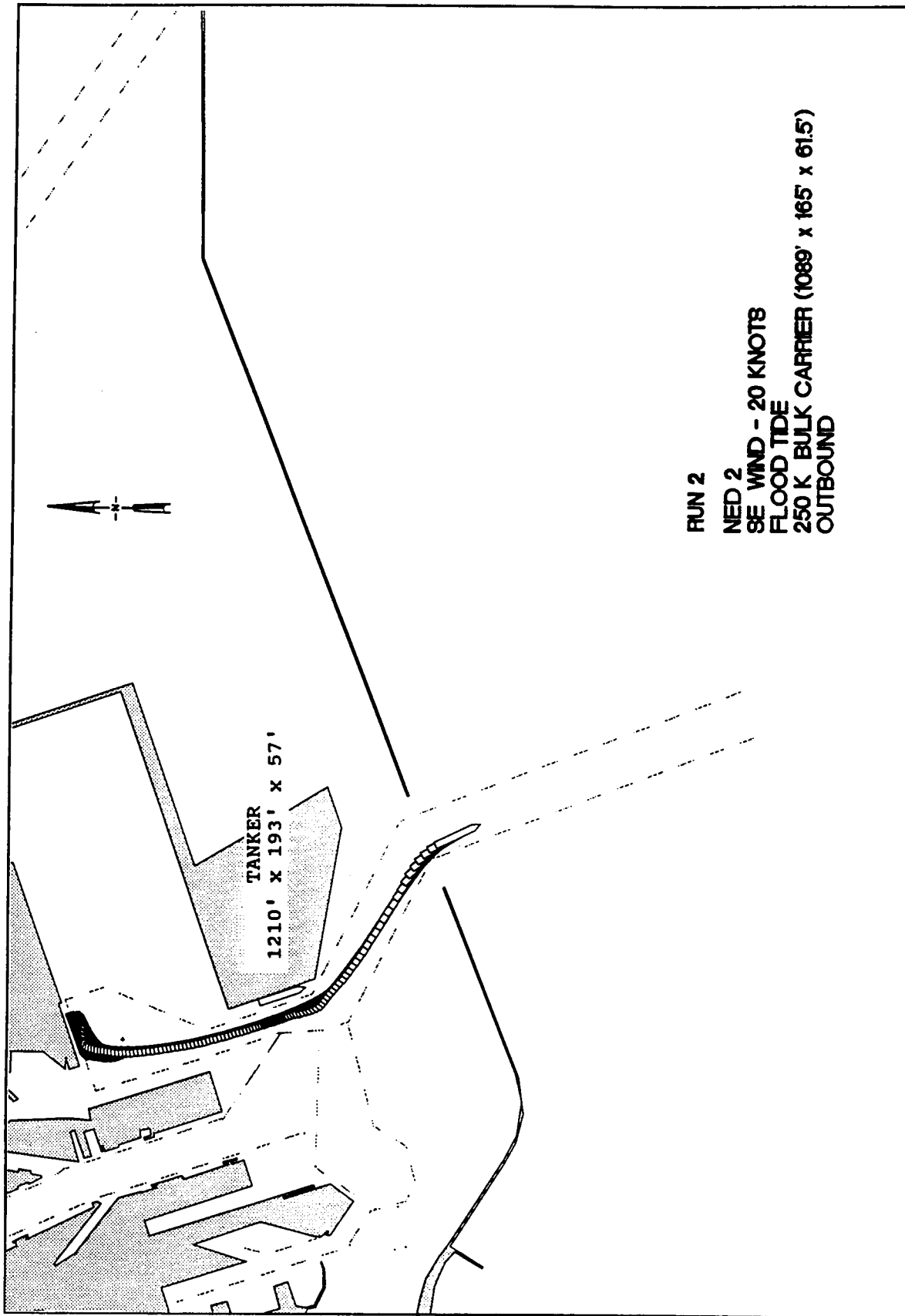
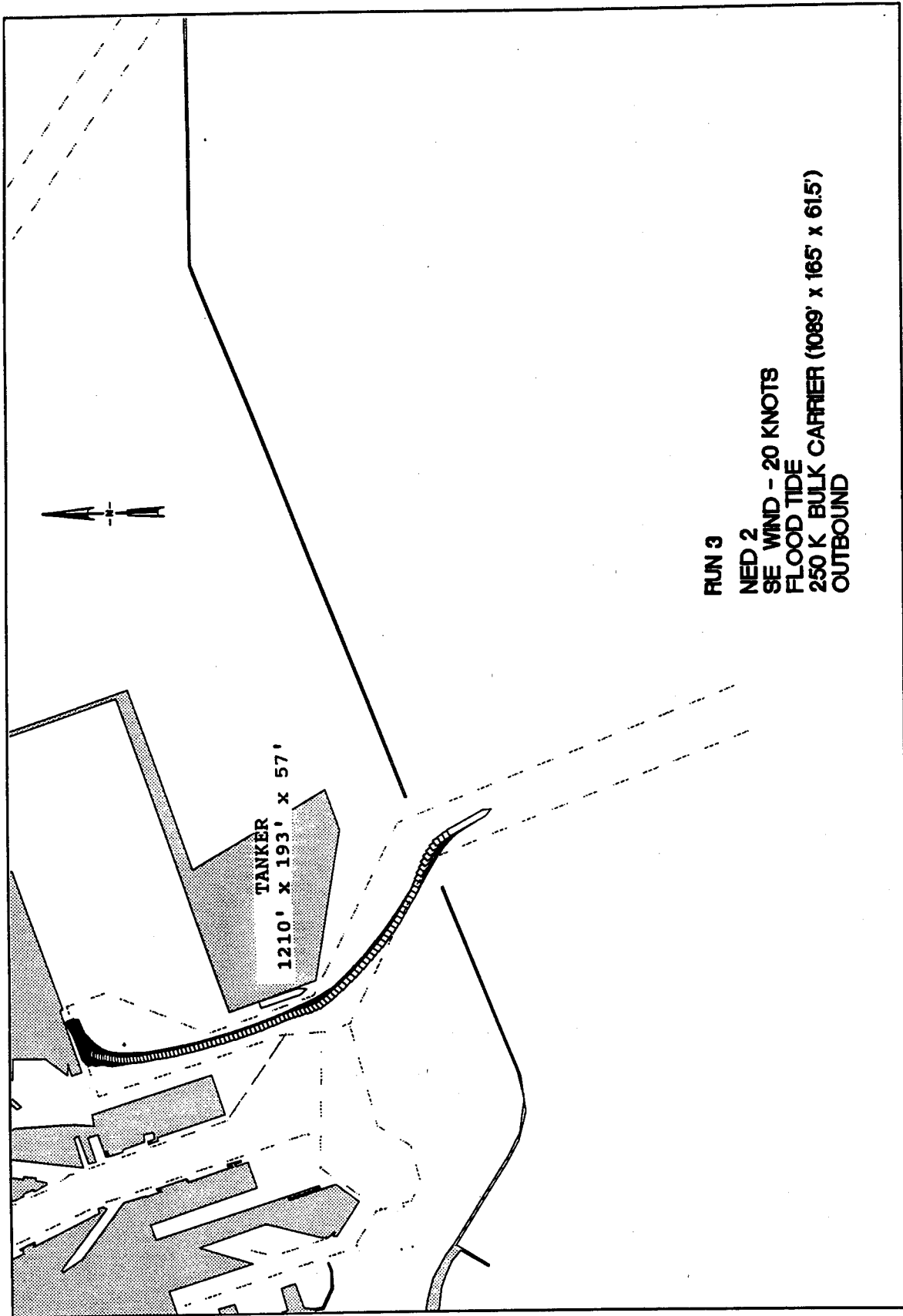
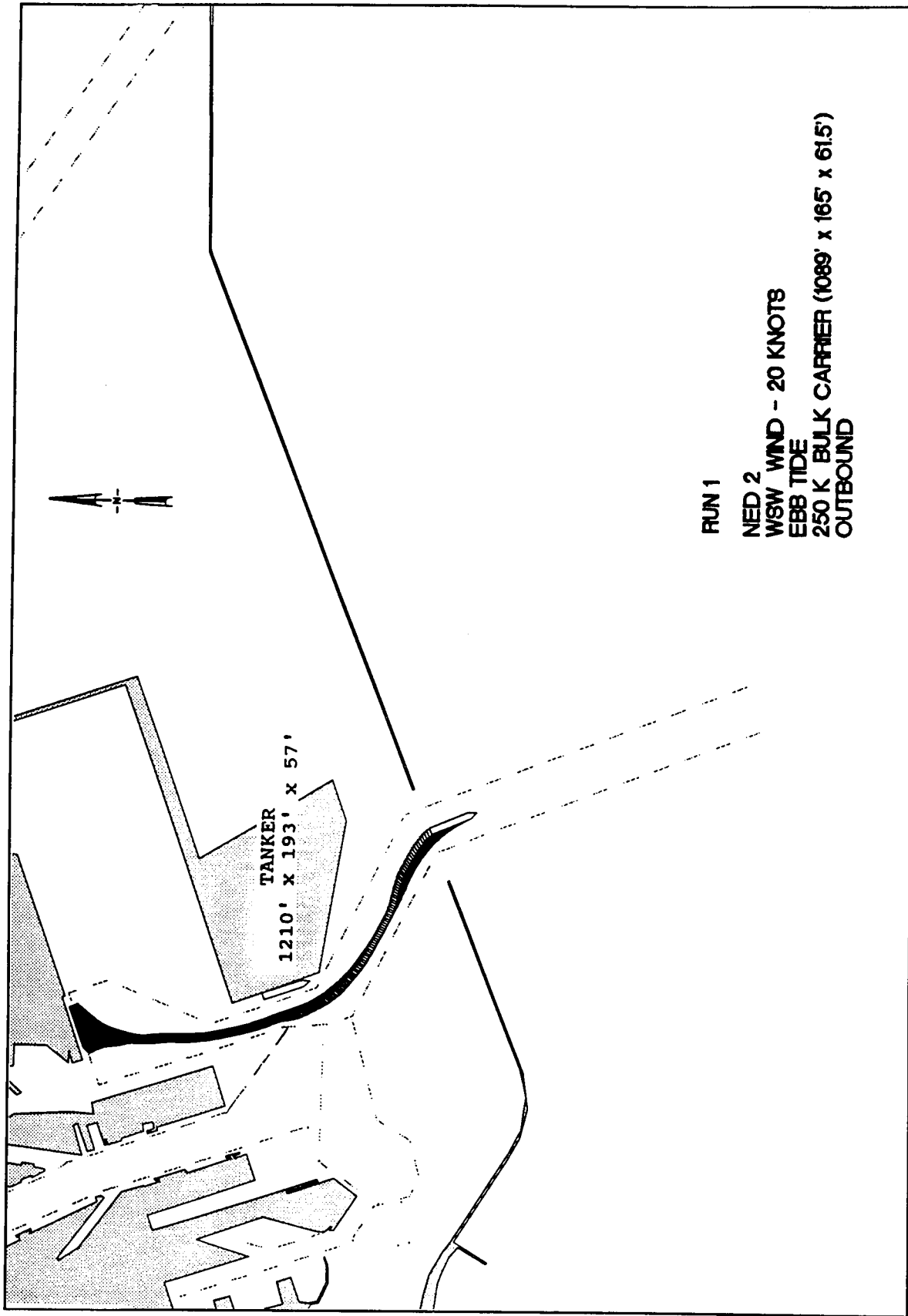

Plate 238



RUN 3  
NED 2  
SE WIND - 20 KNOTS  
FLOOD TIDE  
250 K BULK CARRIER (1089' x 165' x 61.5')  
OUTBOUND

TANKER  
1210' x 193' x 57'



RUN 1  
NED 2  
WSW WIND - 20 KNOTS  
EBB TIDE  
250 K BULK CARRIER (1089' x 165' x 61.5')  
OUTBOUND

Plate 240

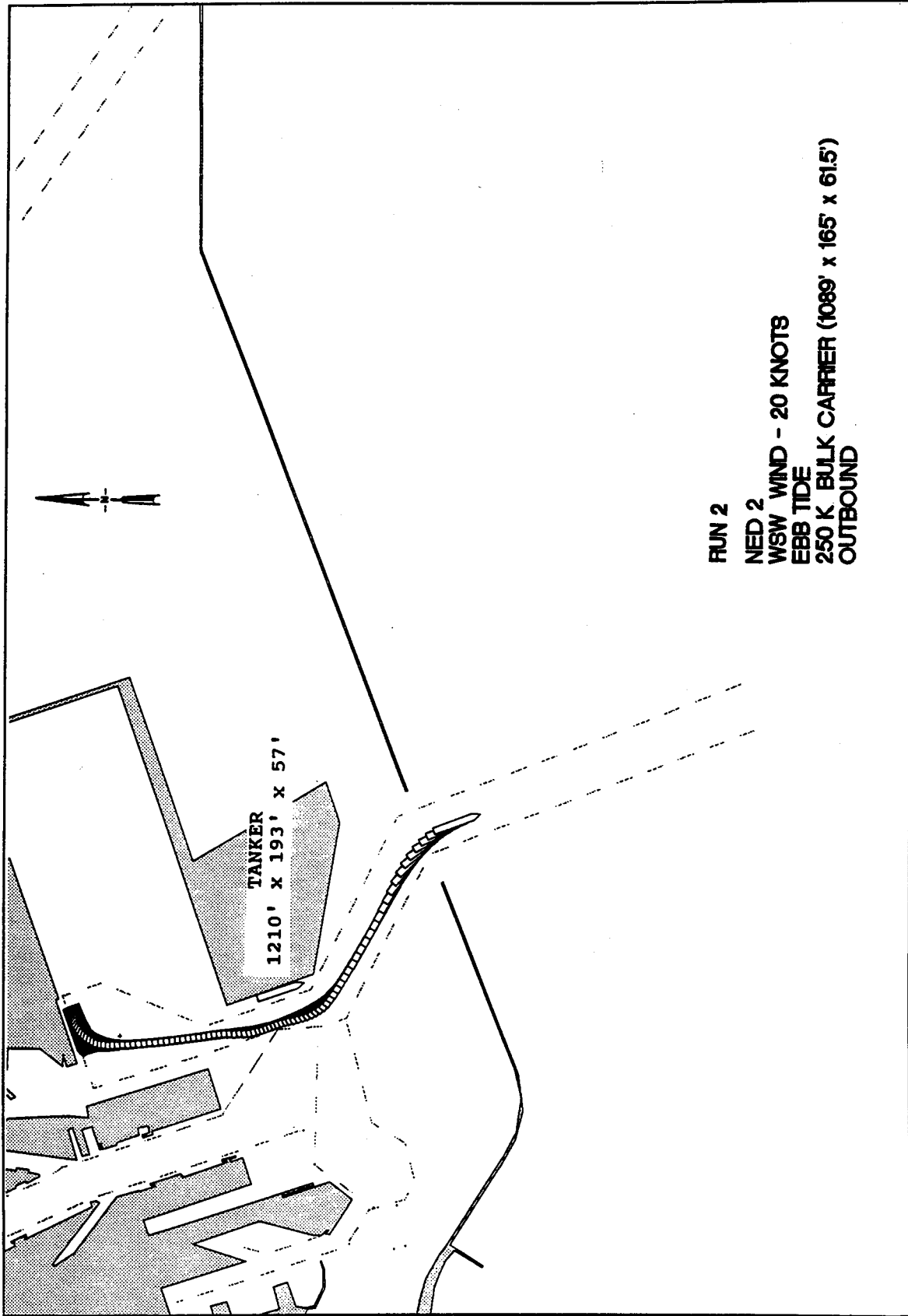

RUN 2  
NED 2  
WSW WIND - 20 KNOTS  
EBB TIDE  
250 K BULK CARRIER (1089' x 165' x 61.5')  
OUTBOUND

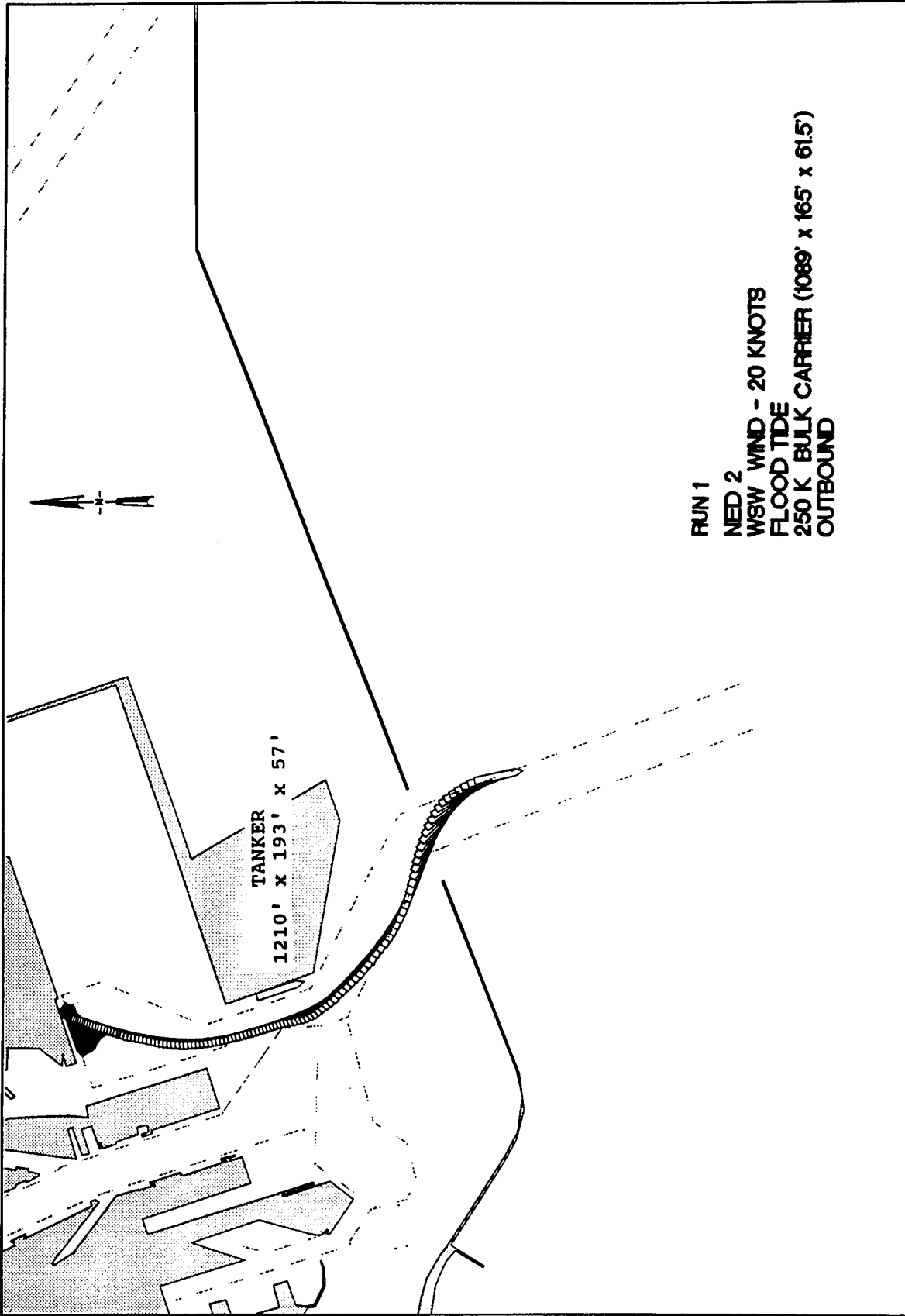
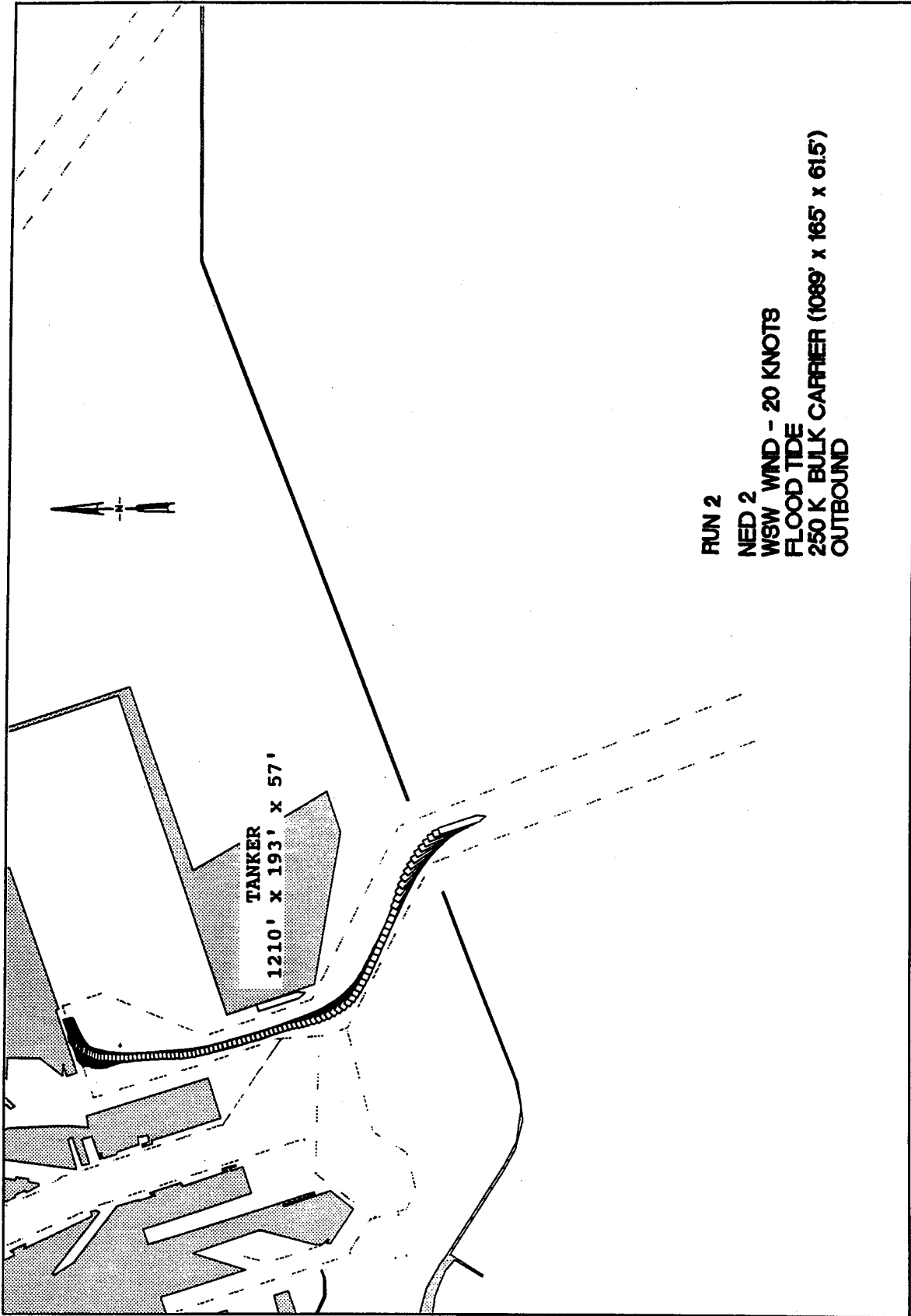

Plate 242



RUN 2  
NED 2  
WSW WIND - 20 KNOTS  
FLOOD TIDE  
250 K BULK CARRIER (1089' x 165' x 61.5')  
OUTBOUND

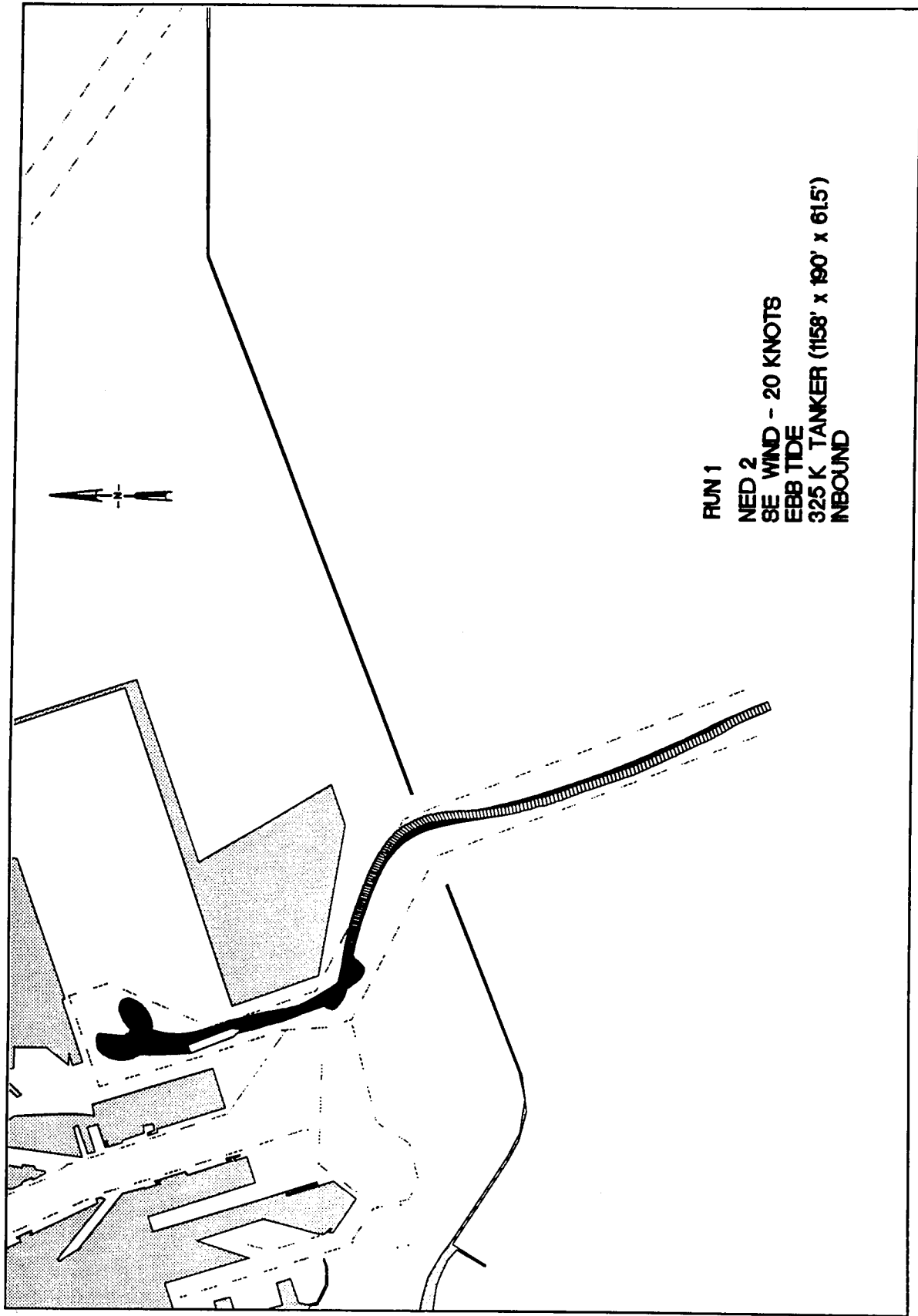
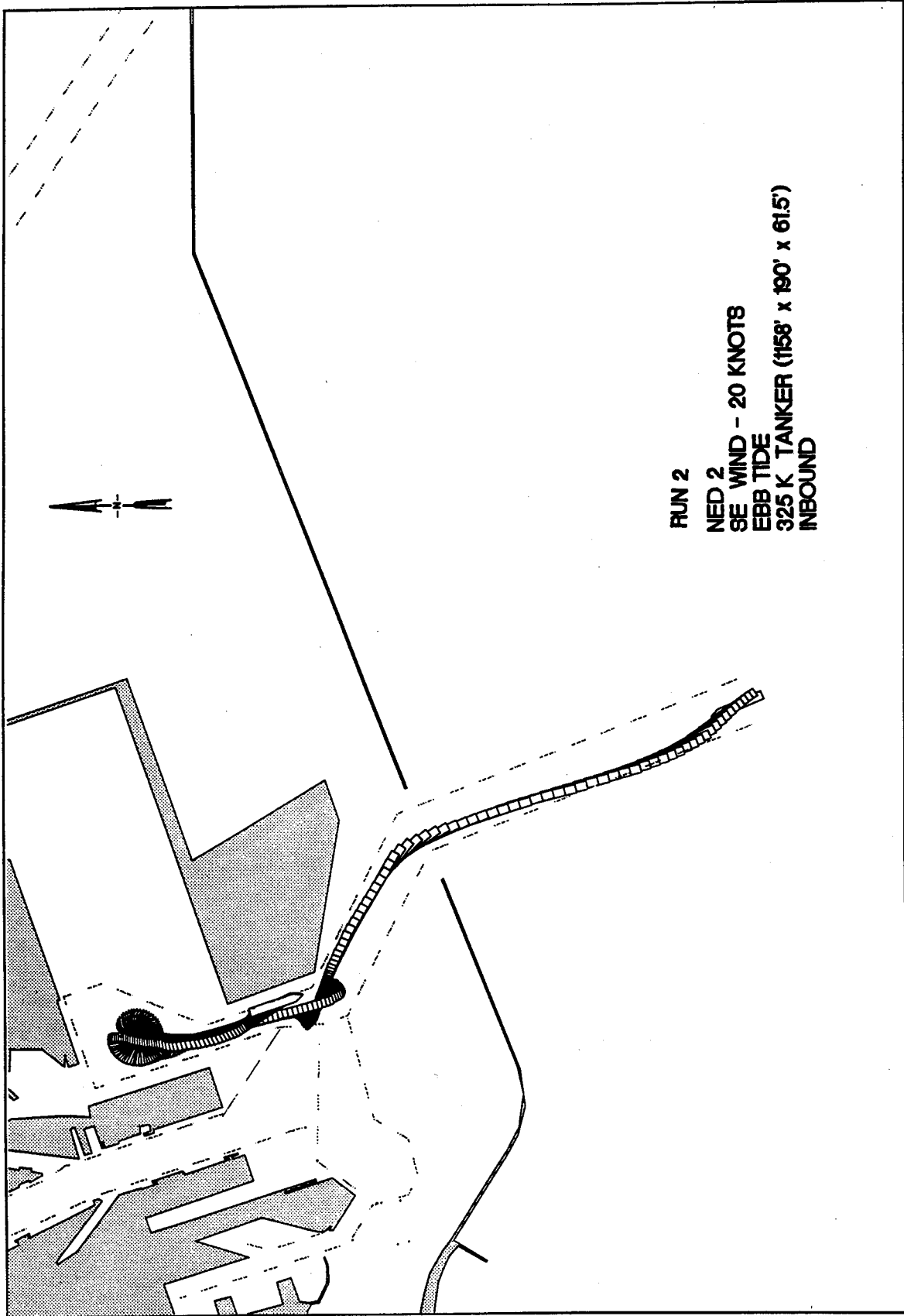

Plate 244



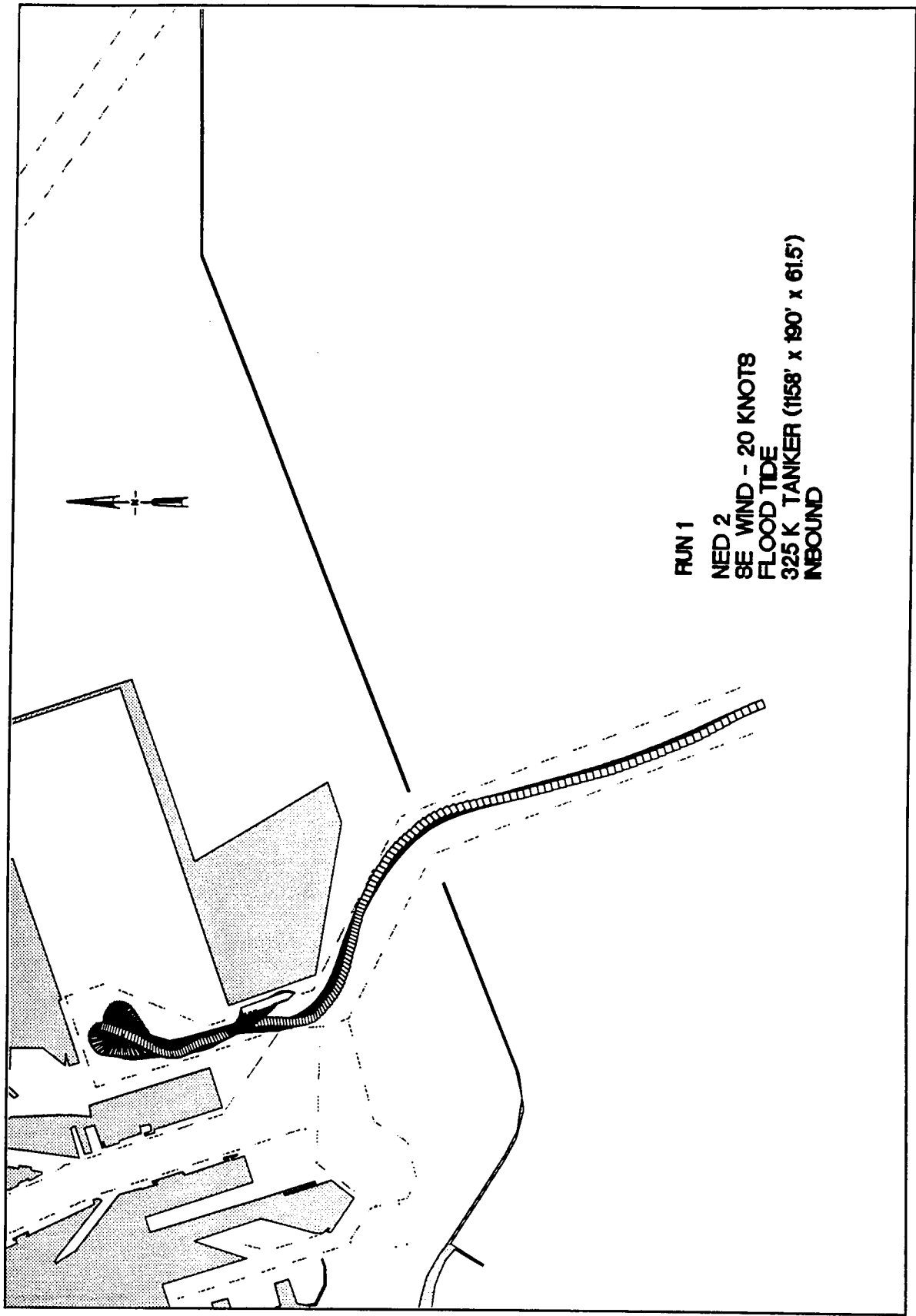
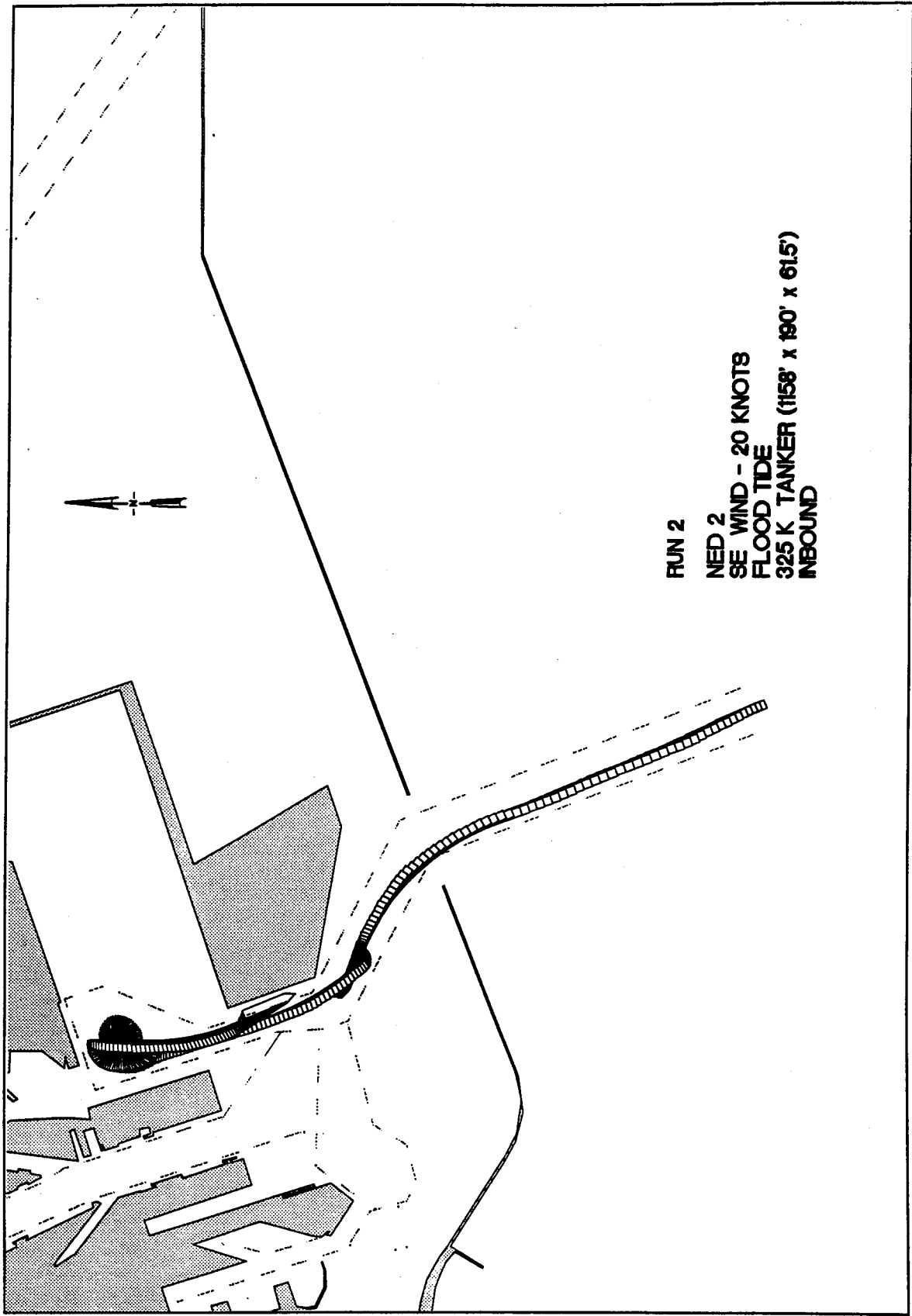

Plate 246



RUN 2  
NED 2  
SE WIND - 20 KNOTS  
FLOOD TIDE  
325 K TANKER (158' x 190' x 61.5')  
INBOUND

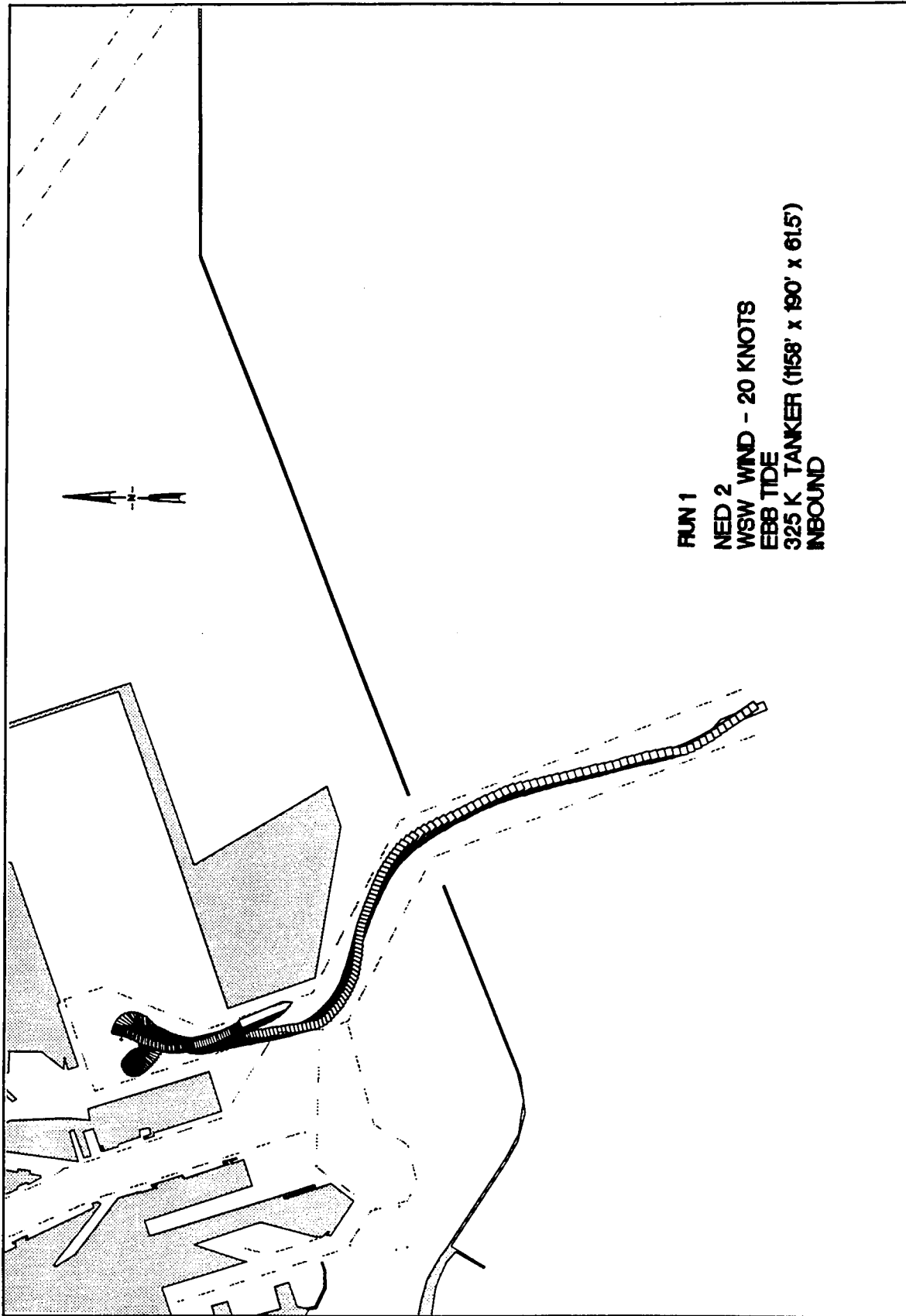
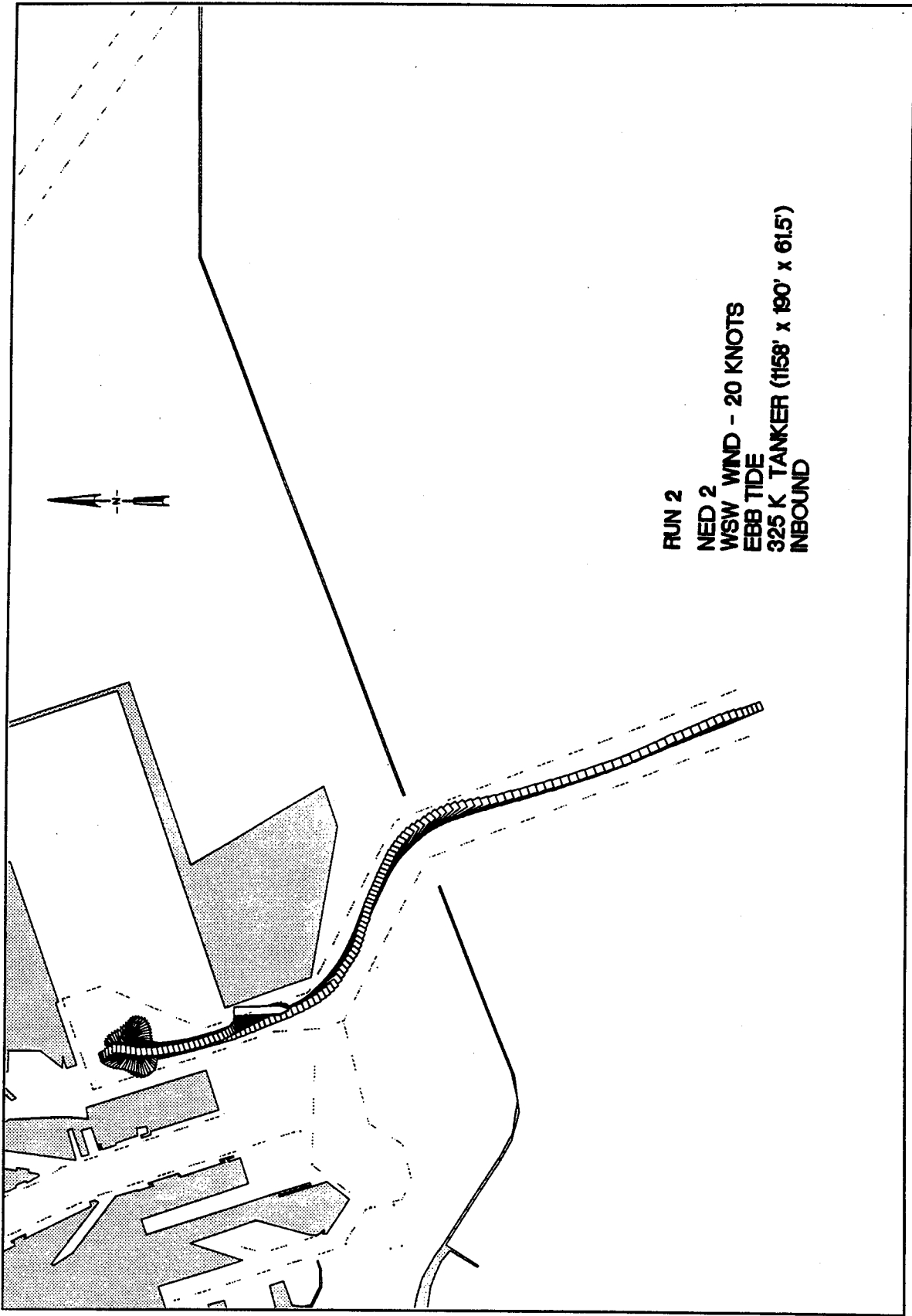

Plate 248



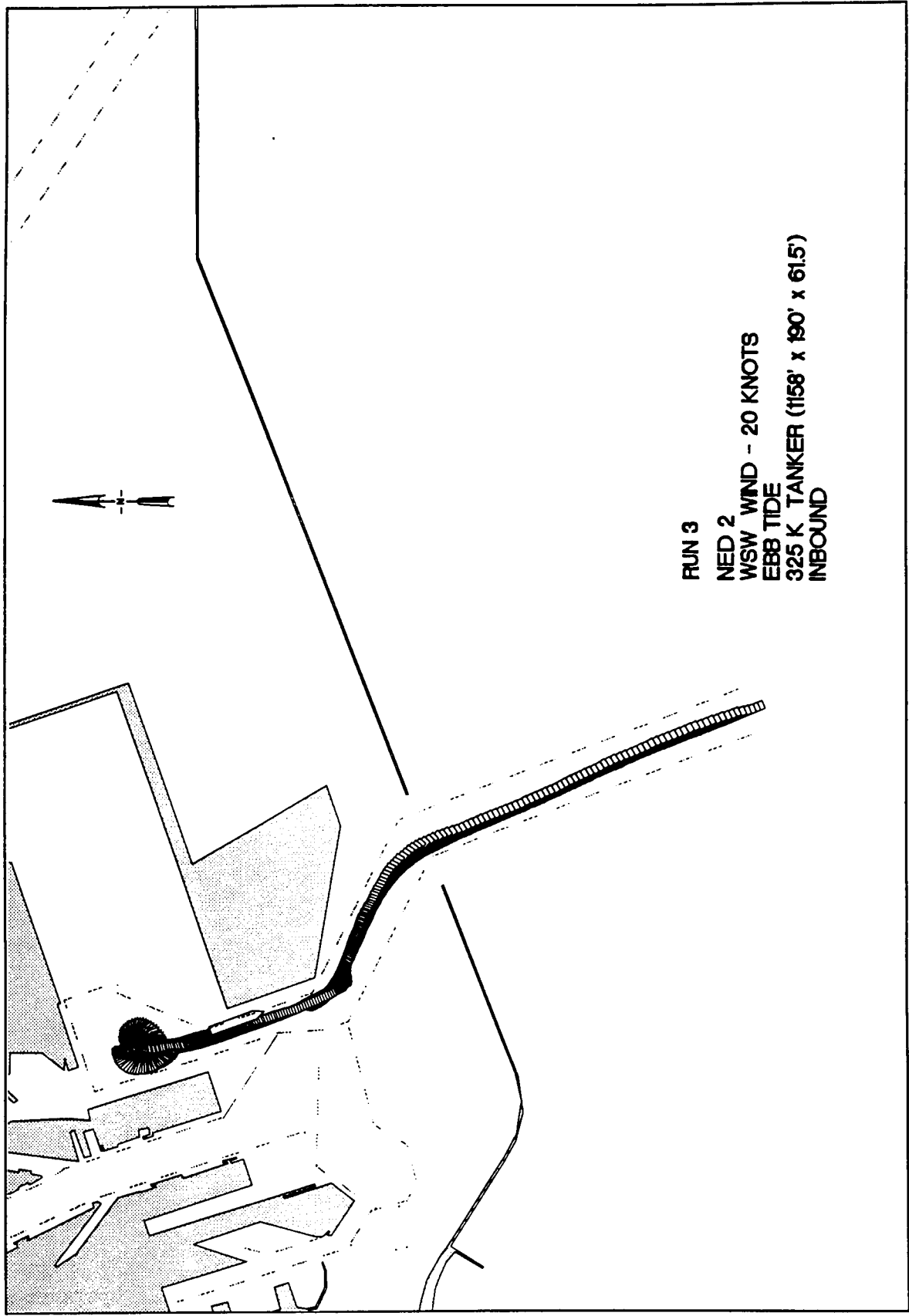
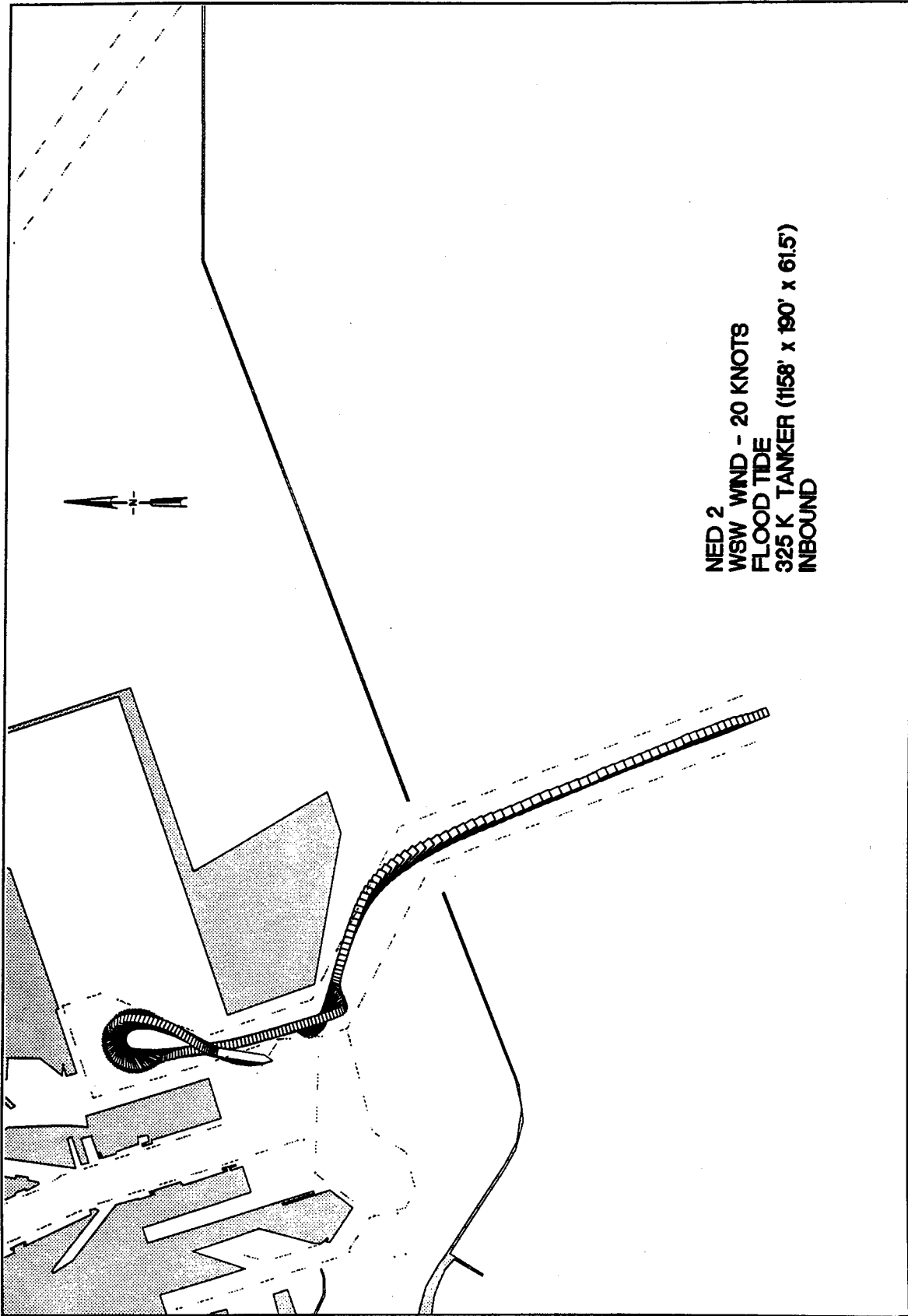
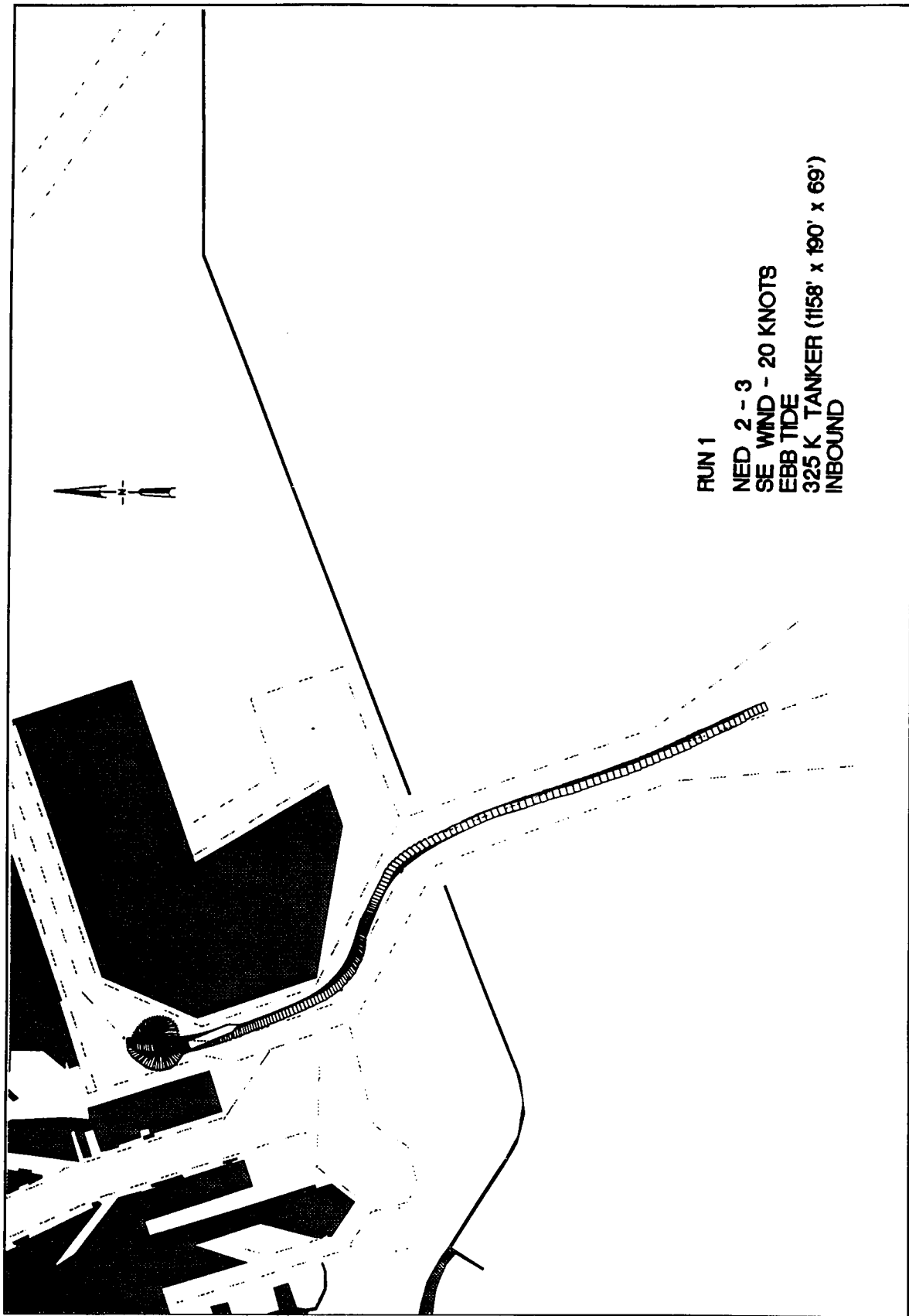

Plate 250



NED 2  
WSW WIND - 20 KNOTS  
FLOOD TIDE  
325 K TANKER (158' x 190' x 61.5')  
INBOUND



RUN 1  
NED 2 - 3  
SE WIND - 20 KNOTS  
EBB TIDE  
325 K TANKER (1158' x 190' x 69')  
INBOUND

Plate 252

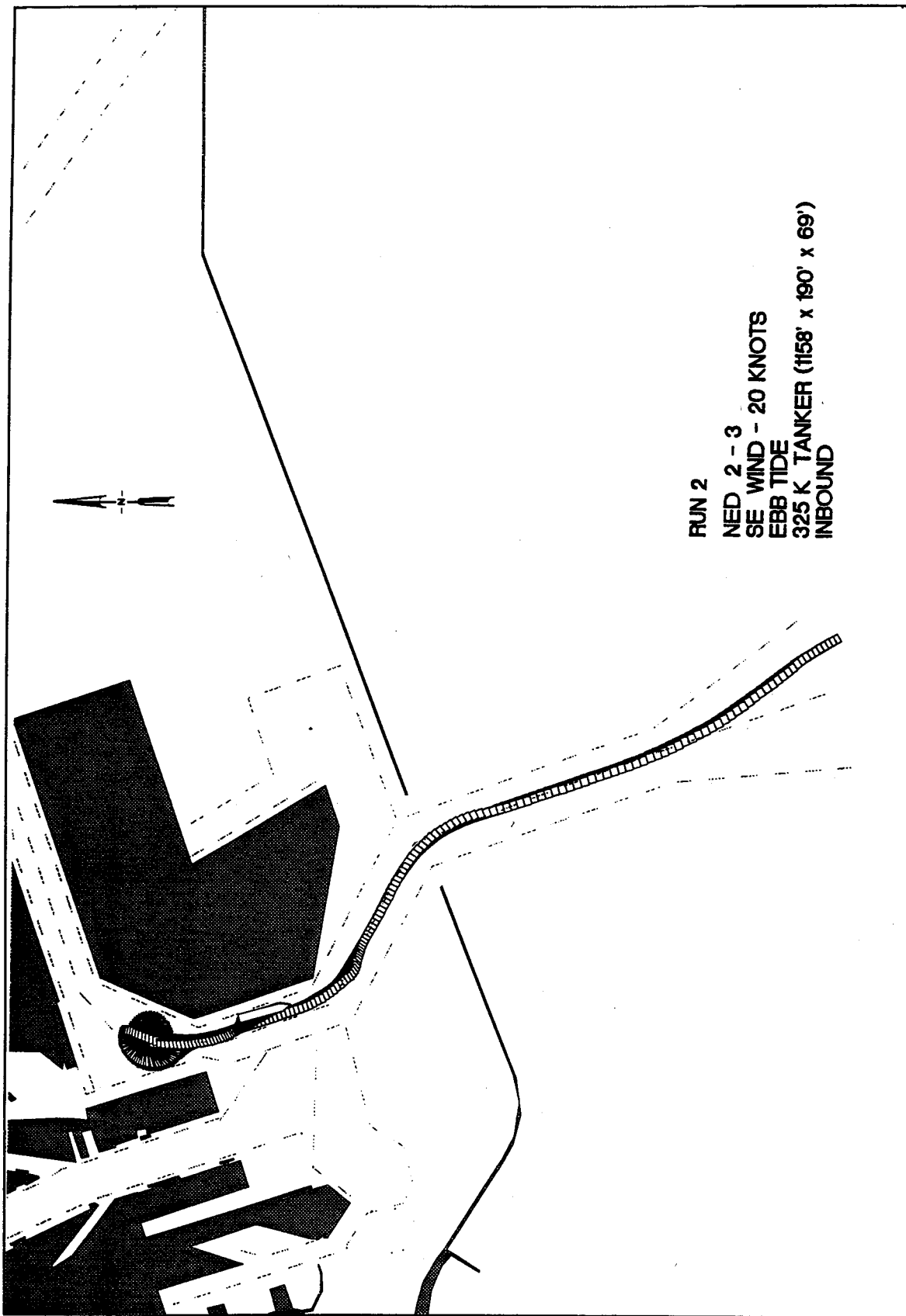

RUN 2  
NED 2 - 3  
SE WIND - 20 KNOTS  
EBB TIDE  
325 K TANKER (1158' x 190' x 69')  
INBOUND

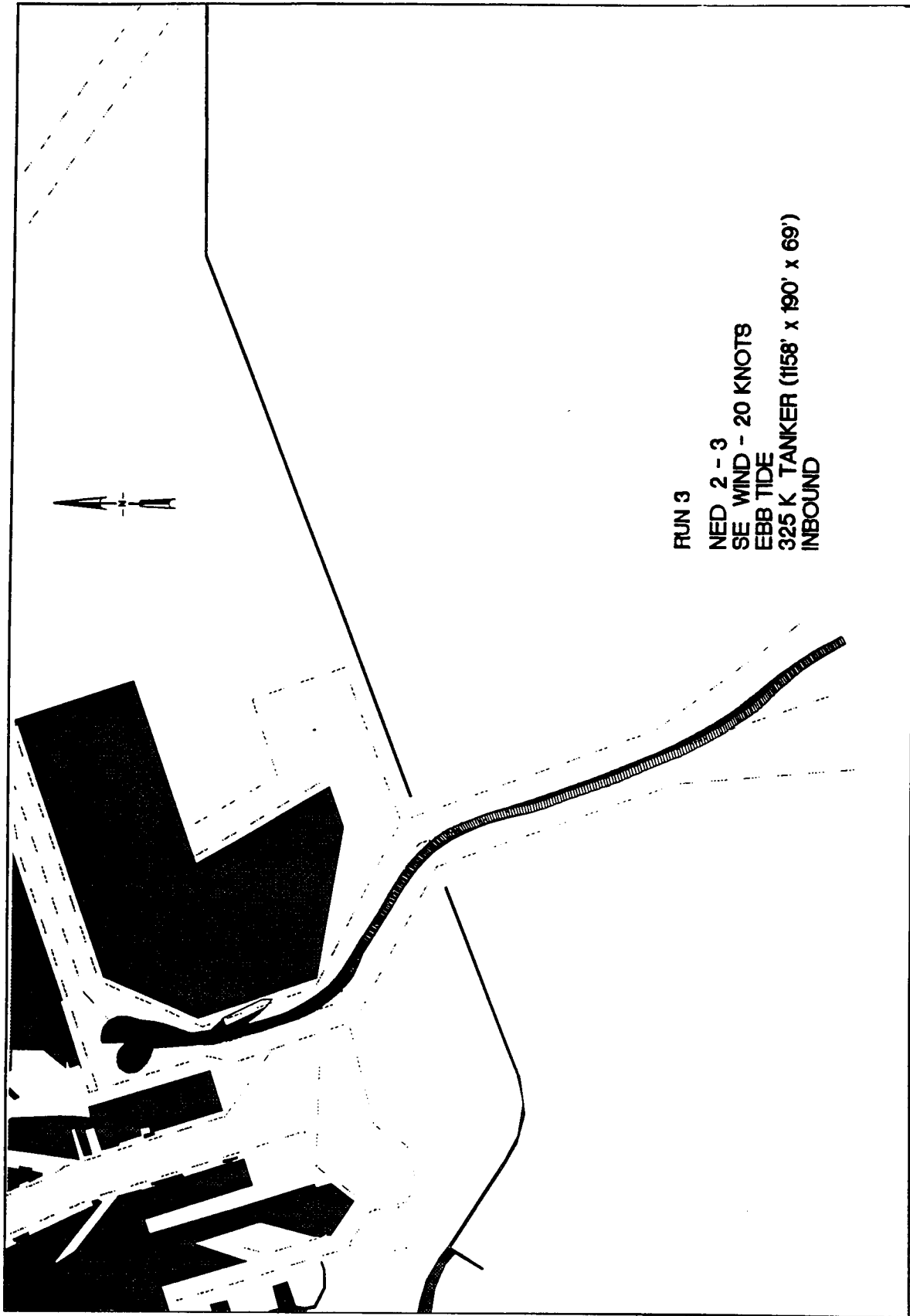

Plate 254

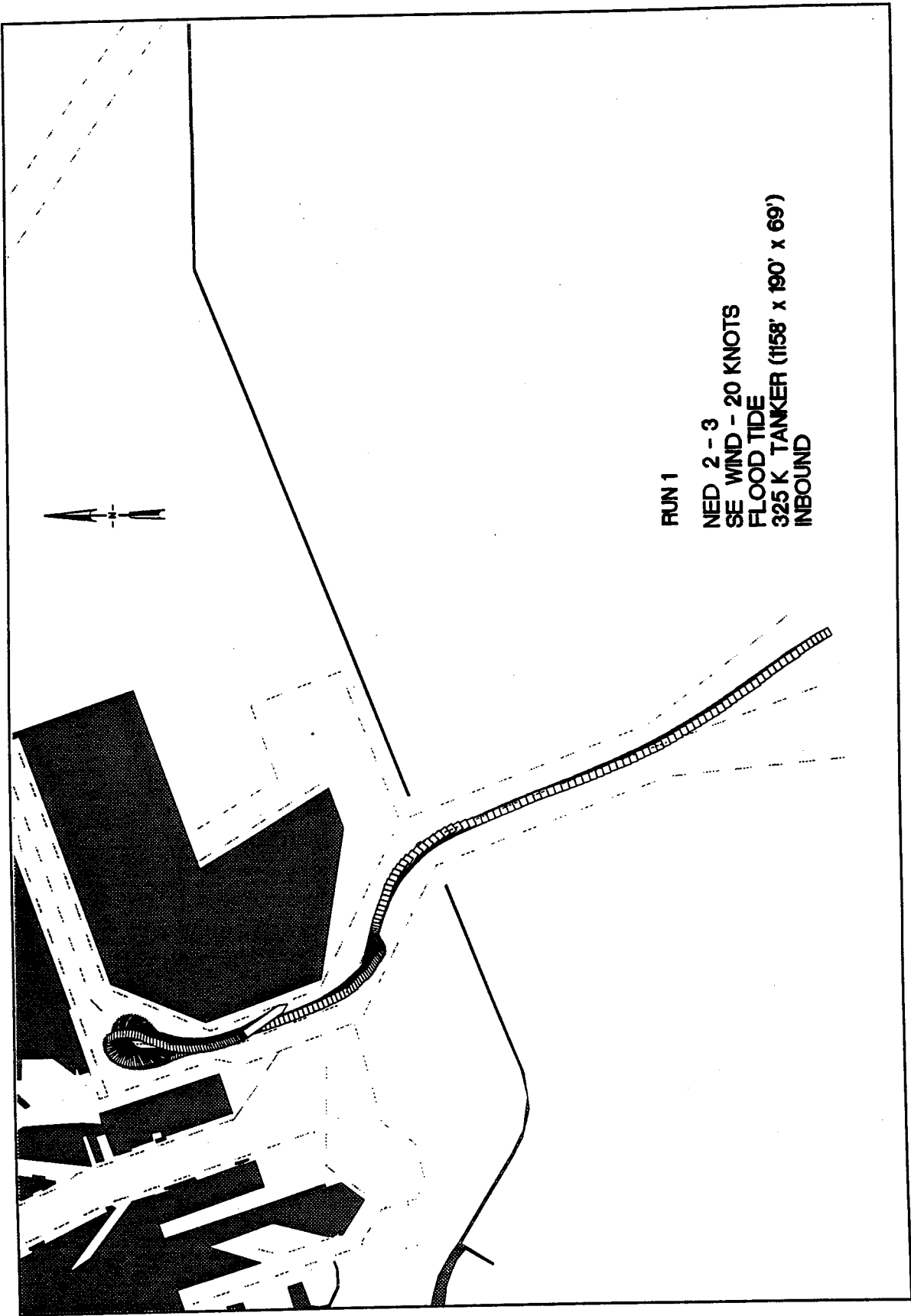

Plate 255

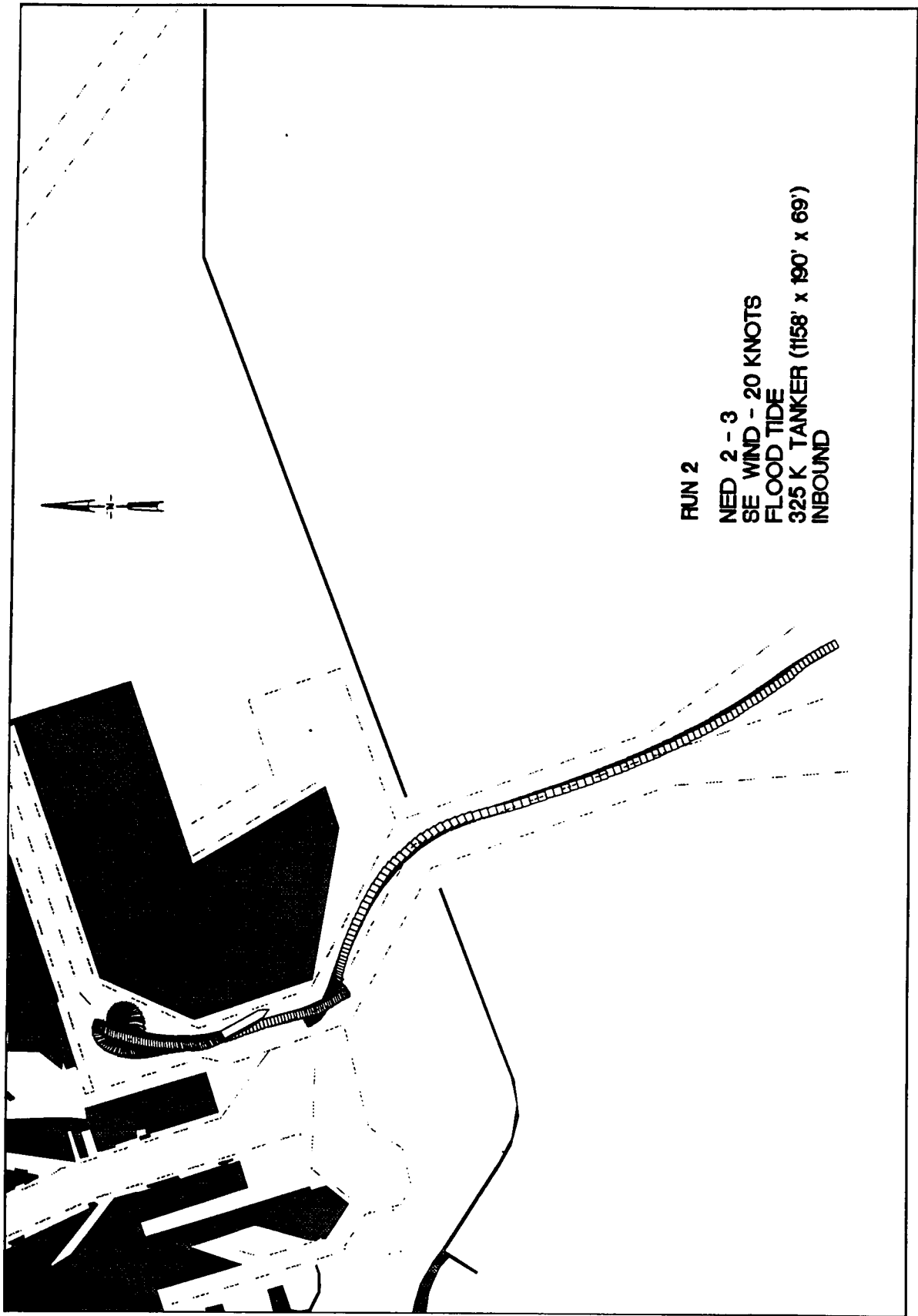
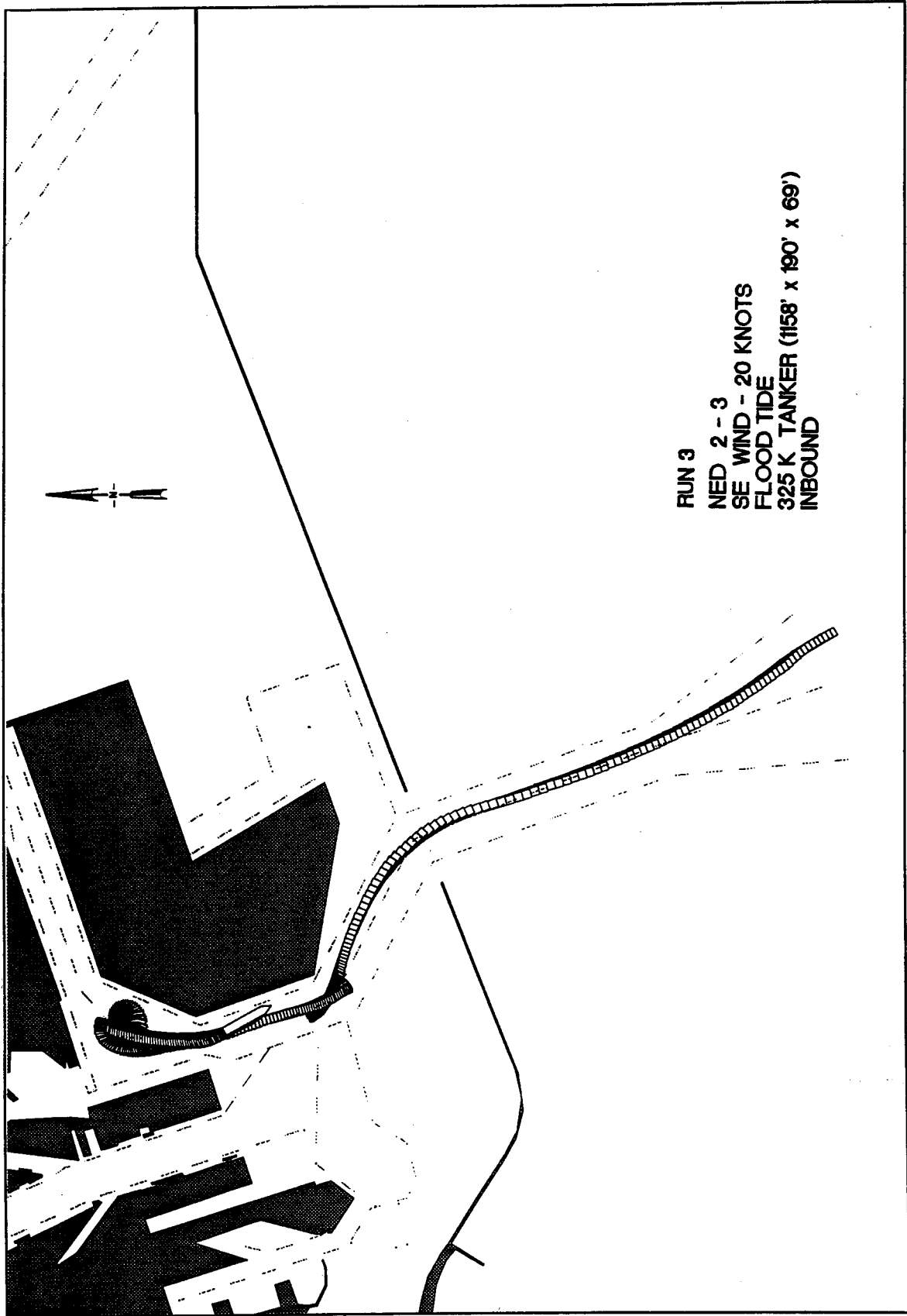
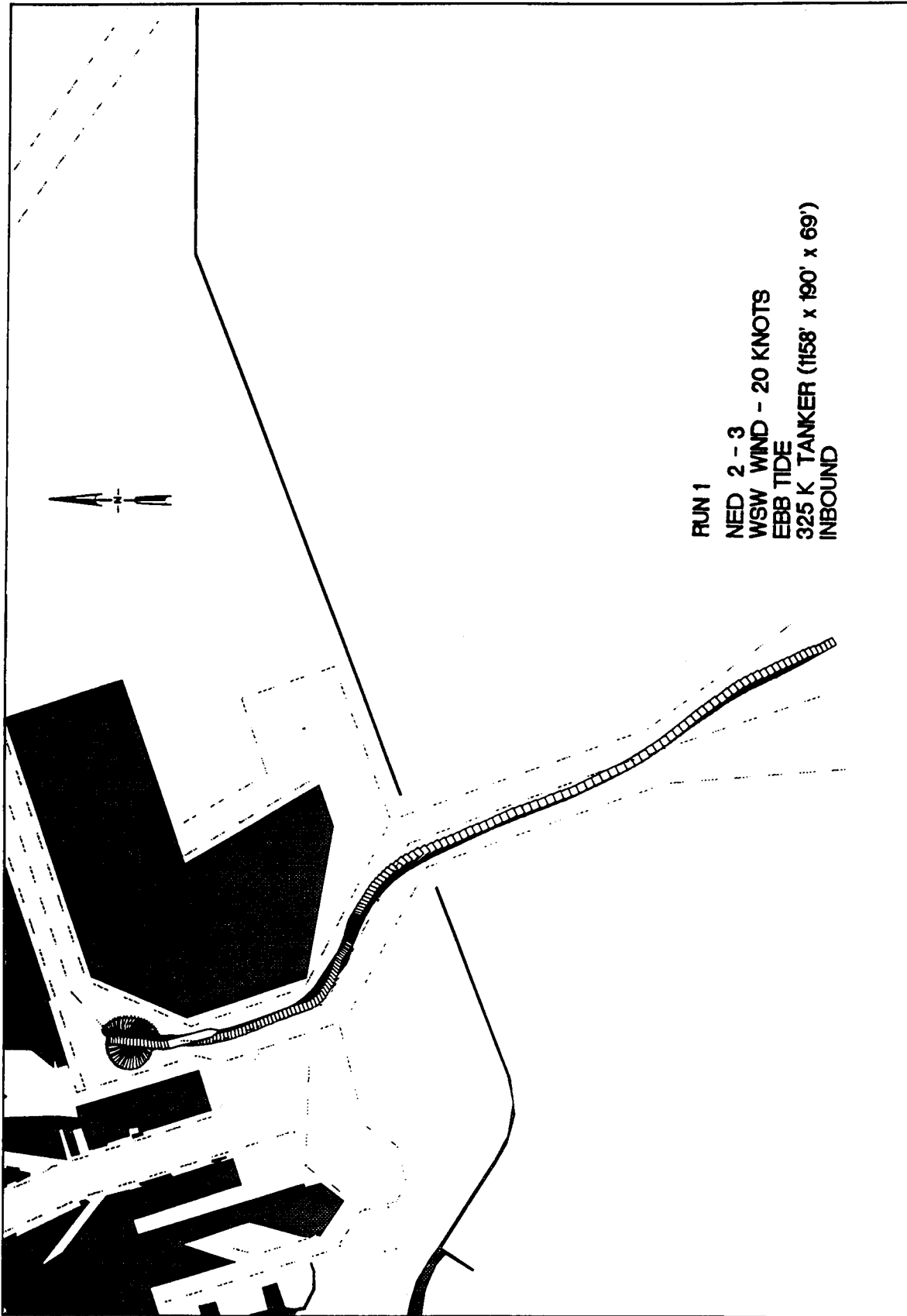

Plate 256



RUN 3  
NED 2-3  
SE WIND - 20 KNOTS  
FLOOD TIDE  
325 K TANKER (1158' x 190' x 69')  
INBOUND



RUN 1  
NED 2-3  
WSW WIND - 20 KNOTS  
EBB TIDE  
325 K TANKER (1158' x 190' x 69')  
INBOUND

Plate 258

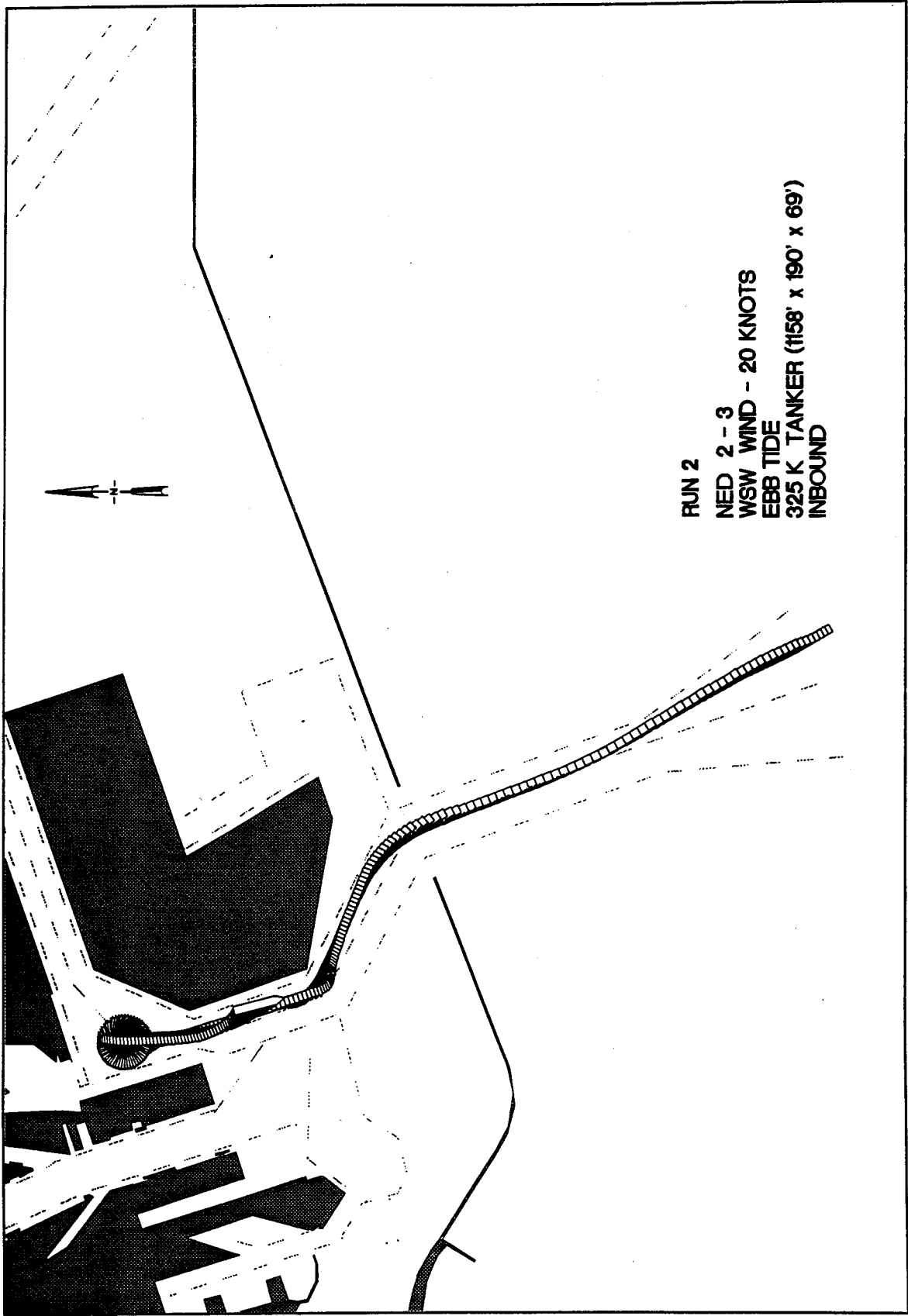

RUN 2  
NED 2 - 3  
WSW WIND - 20 KNOTS  
EBB TIDE  
325 K TANKER (1158' x 190' x 69')  
INBOUND

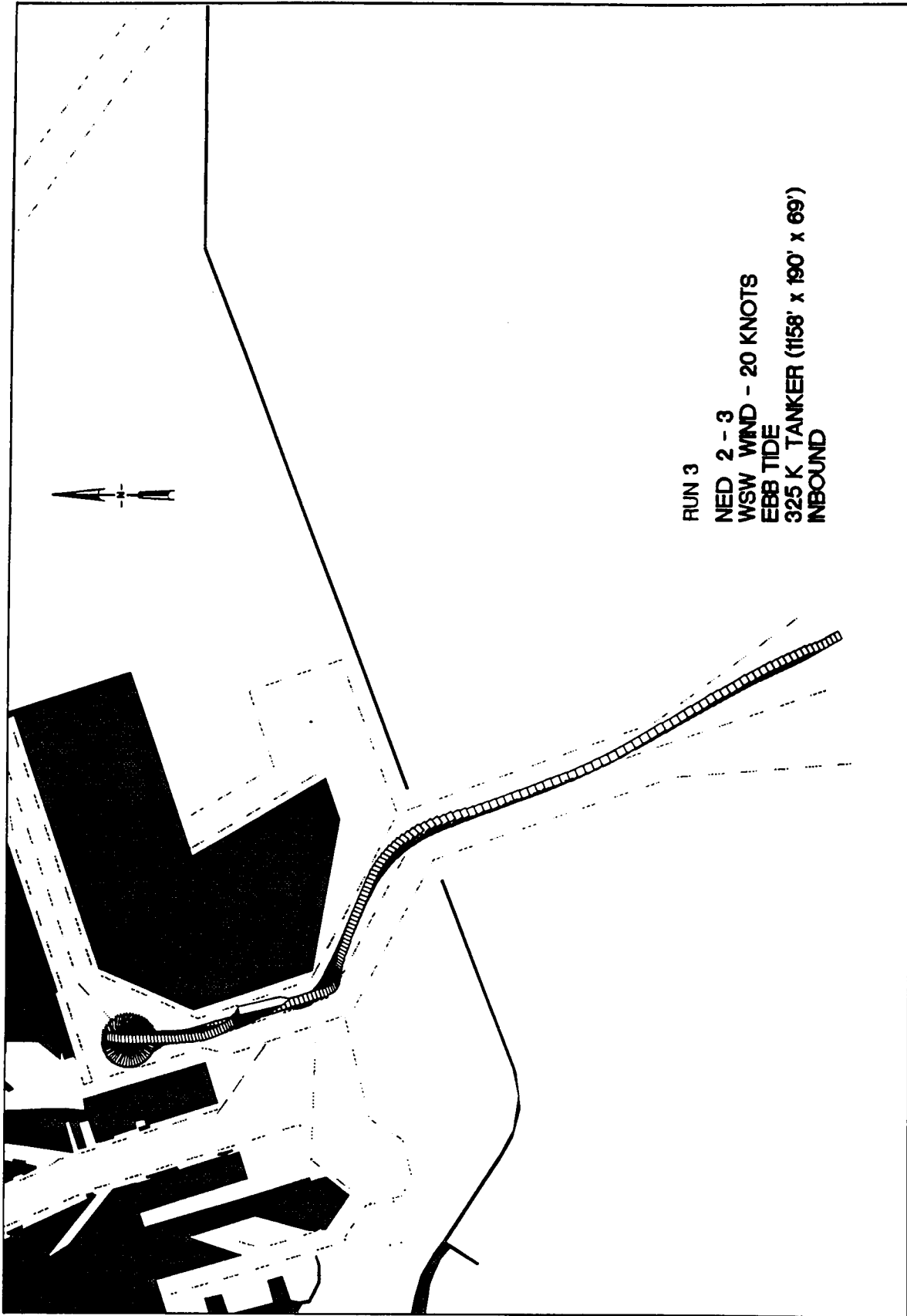
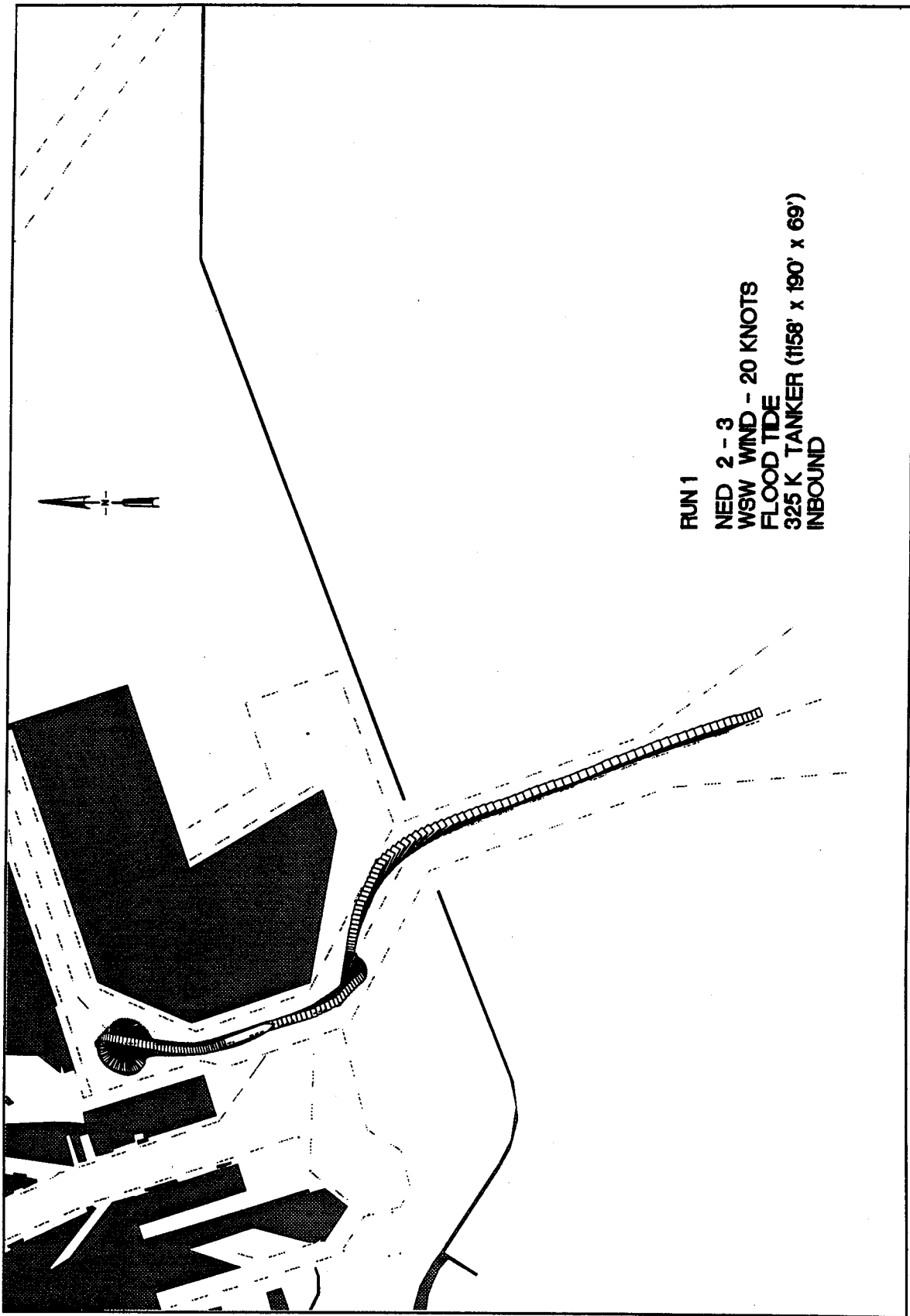

Plate 260



RUN 1  
NED 2-3  
WSW WIND - 20 KNOTS  
FLOOD TIDE  
325 K. TANKER (1158' x 190' x 69')  
INBOUND

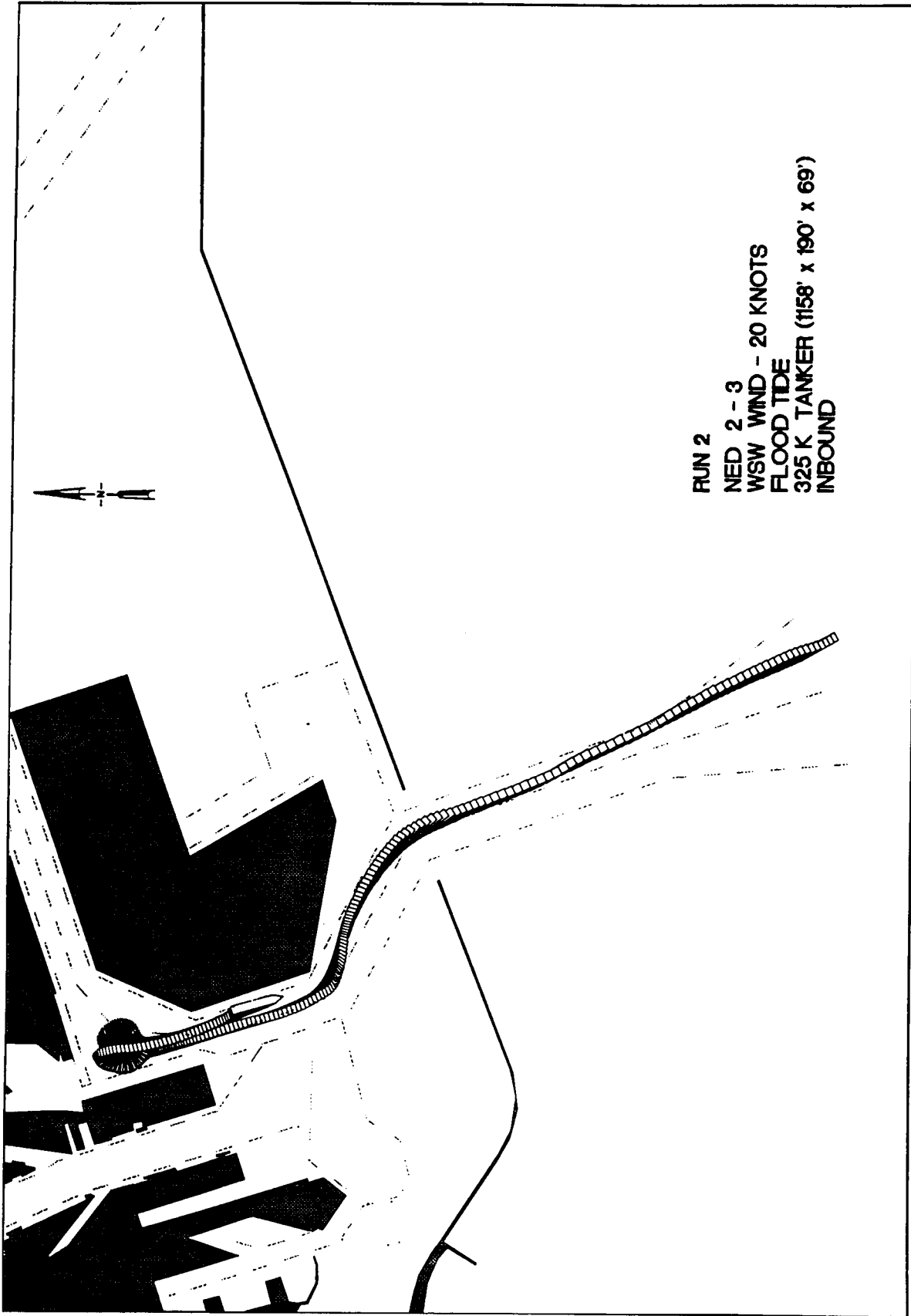

Plate 262

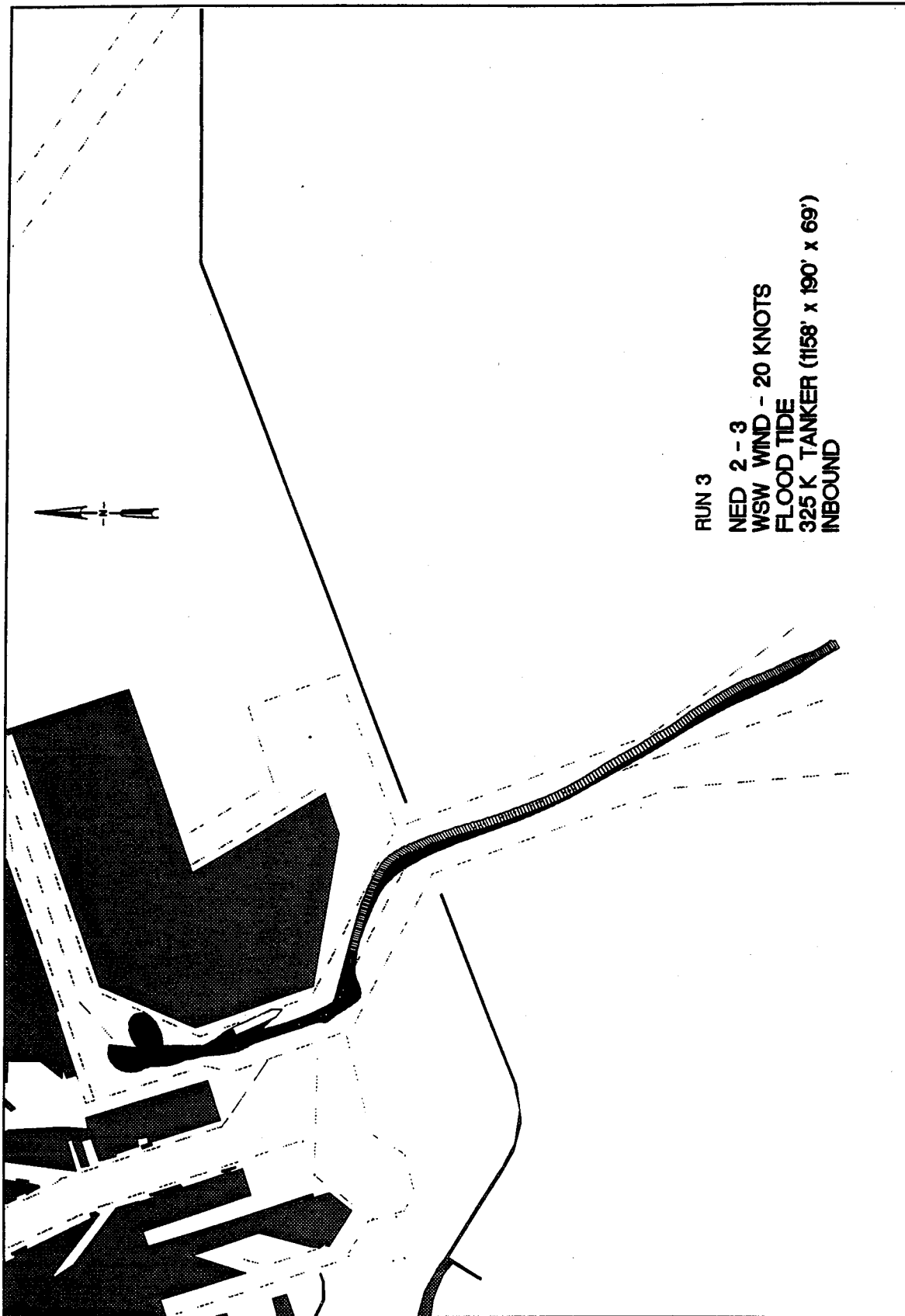

Plate 263

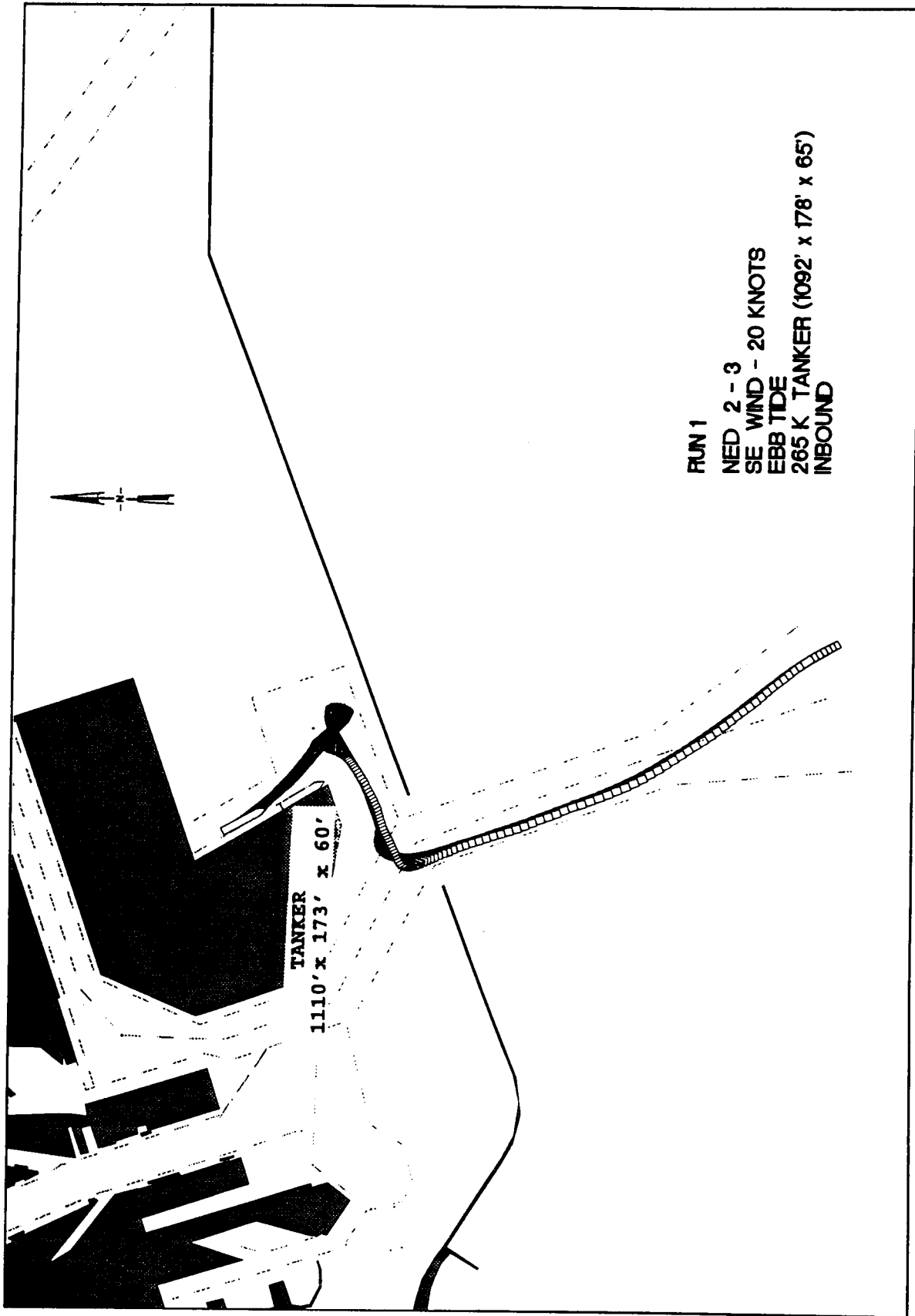

Plate 264

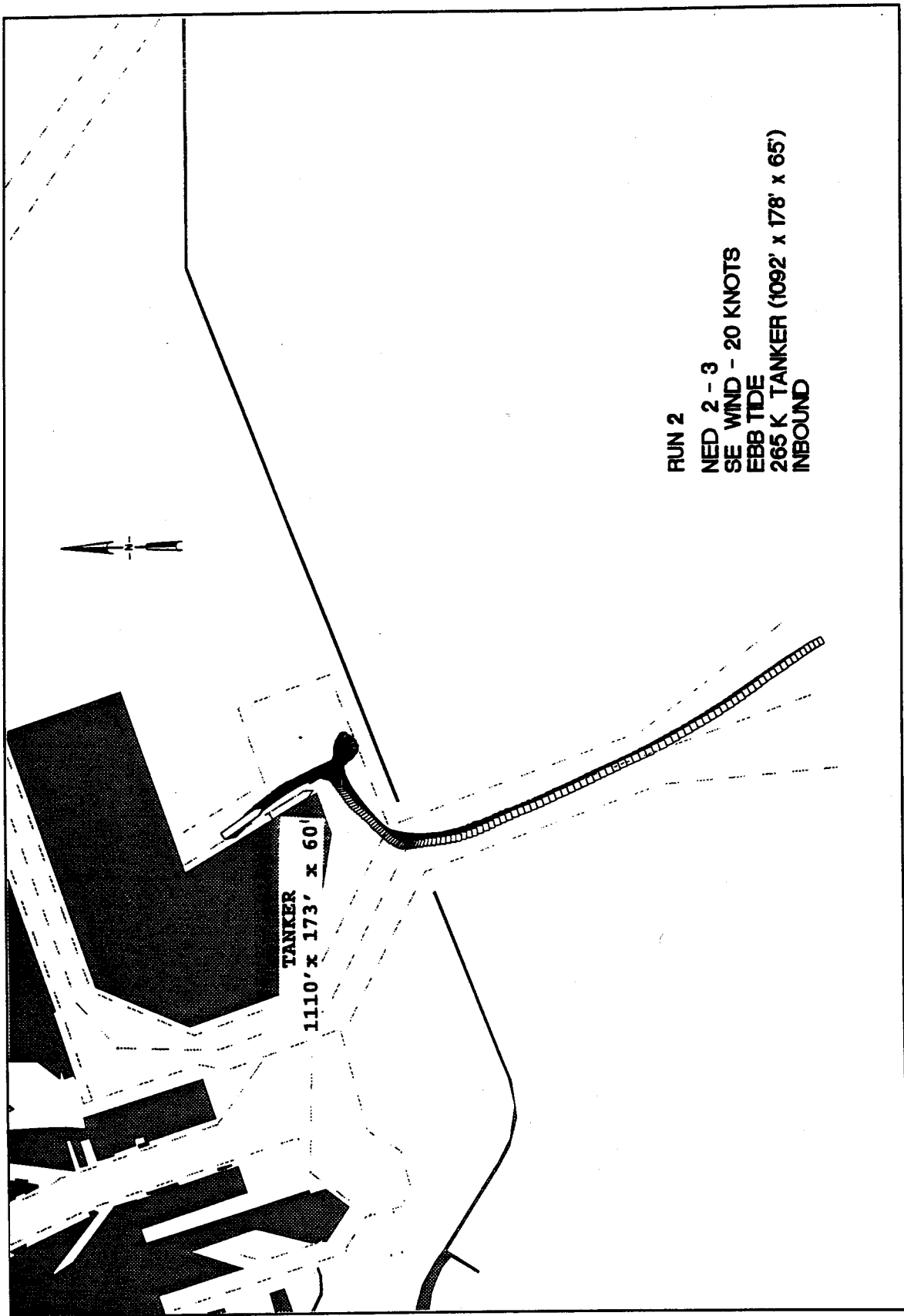
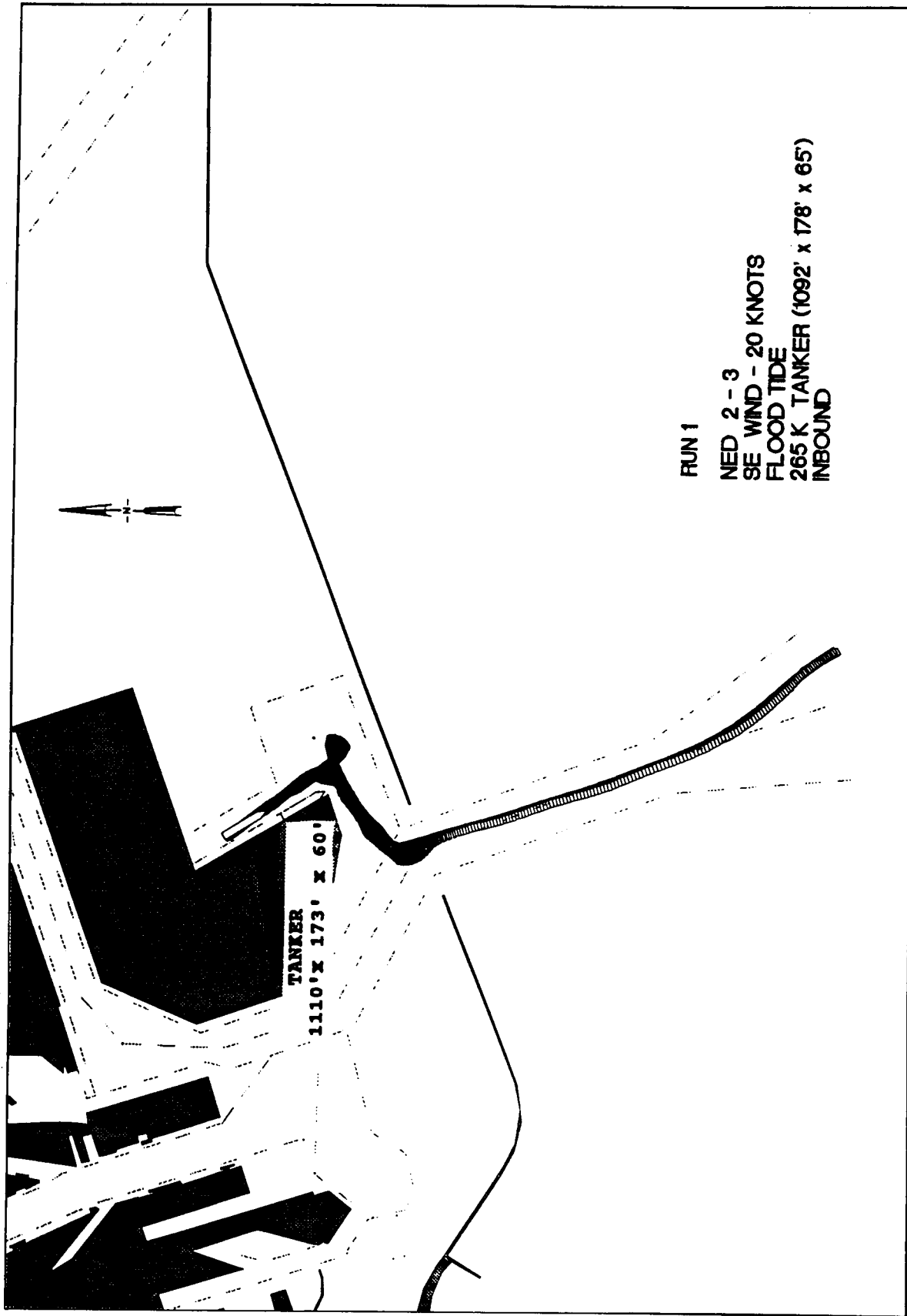

Plate 265



RUN 1  
NED 2 - 3  
SE WIND - 20 KNOTS  
FLOOD TIDE  
265 K TANKER (1092' x 178' x 65')  
INBOUND

Plate 266

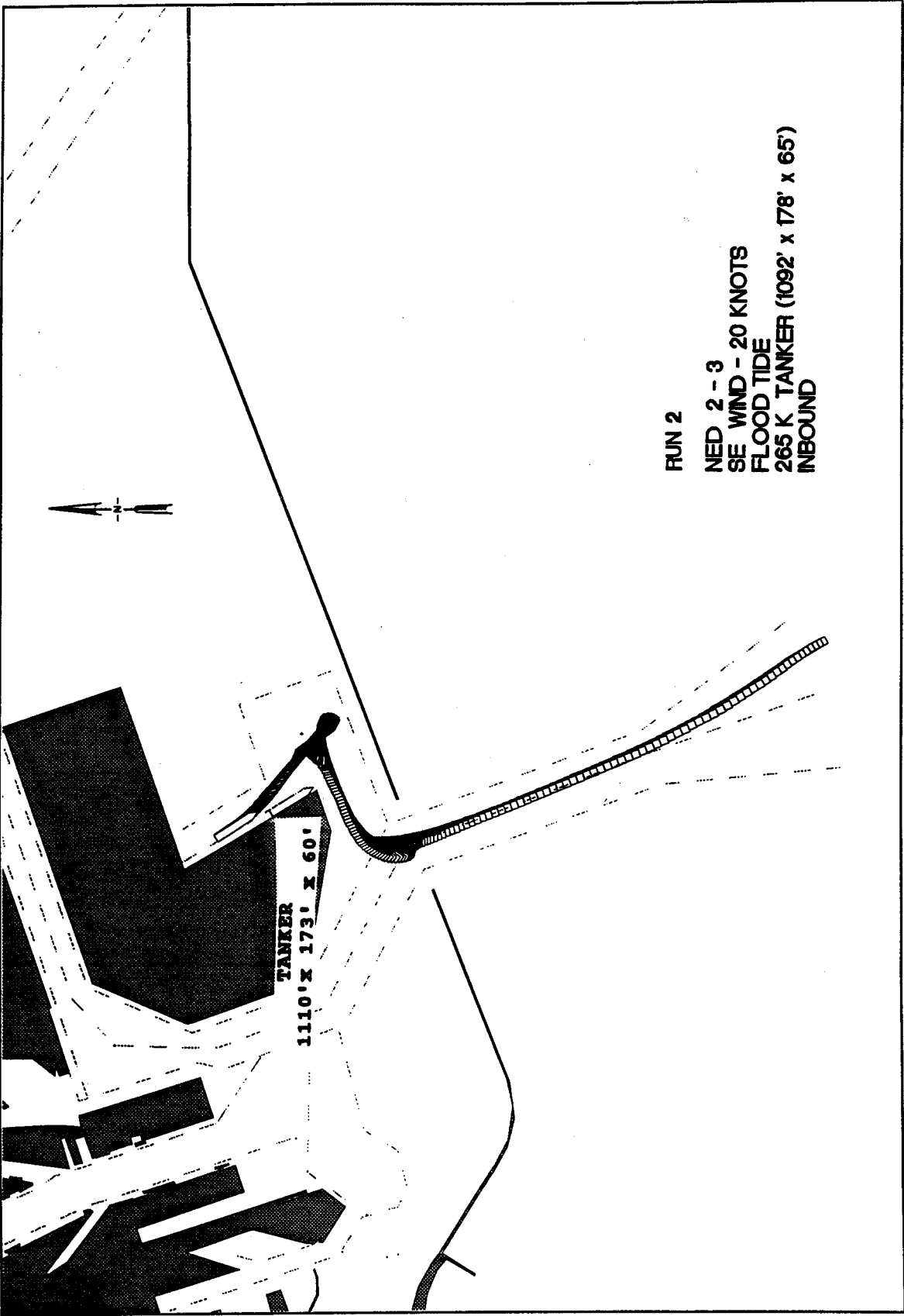

Plate 267

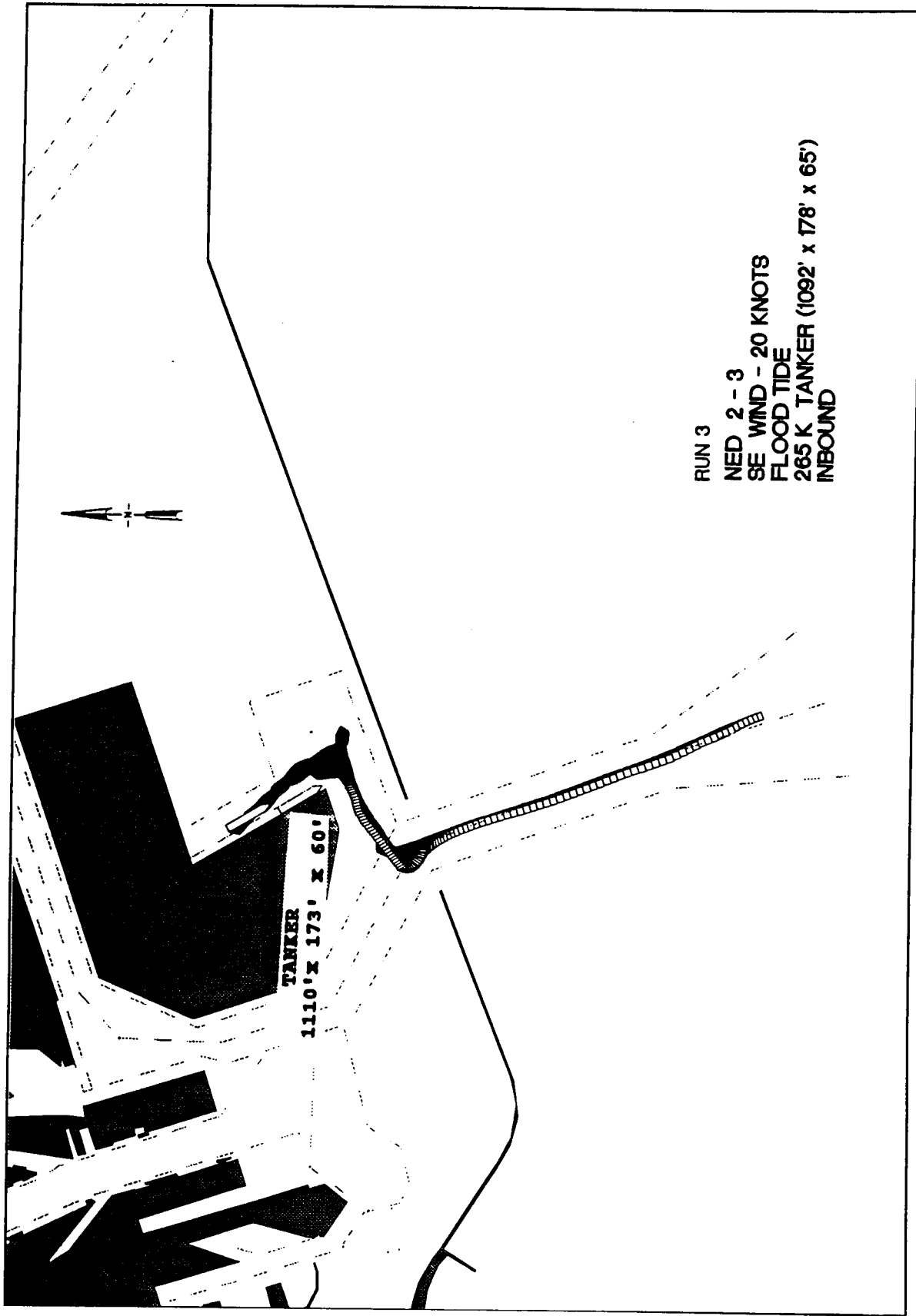
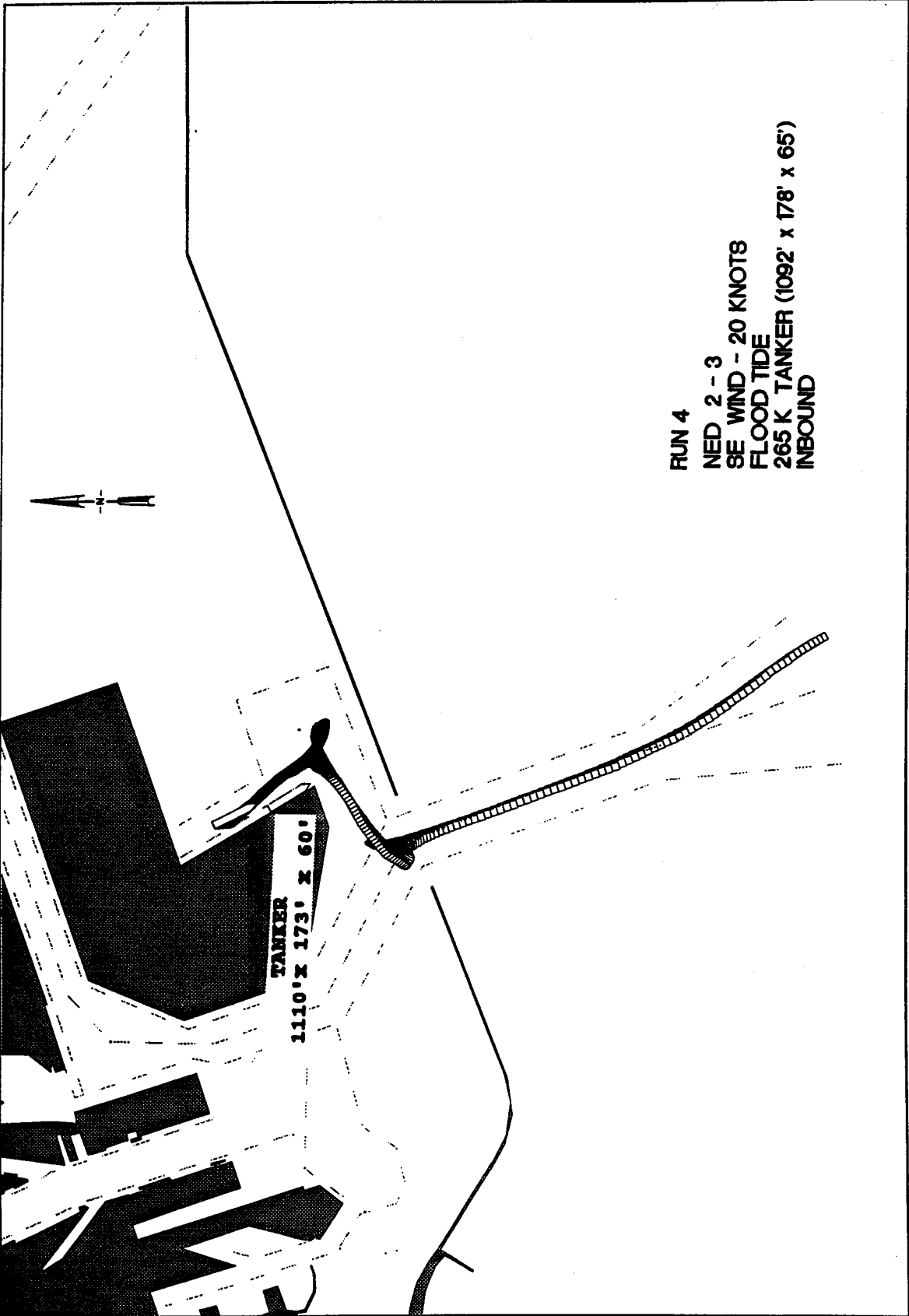

Plate 268



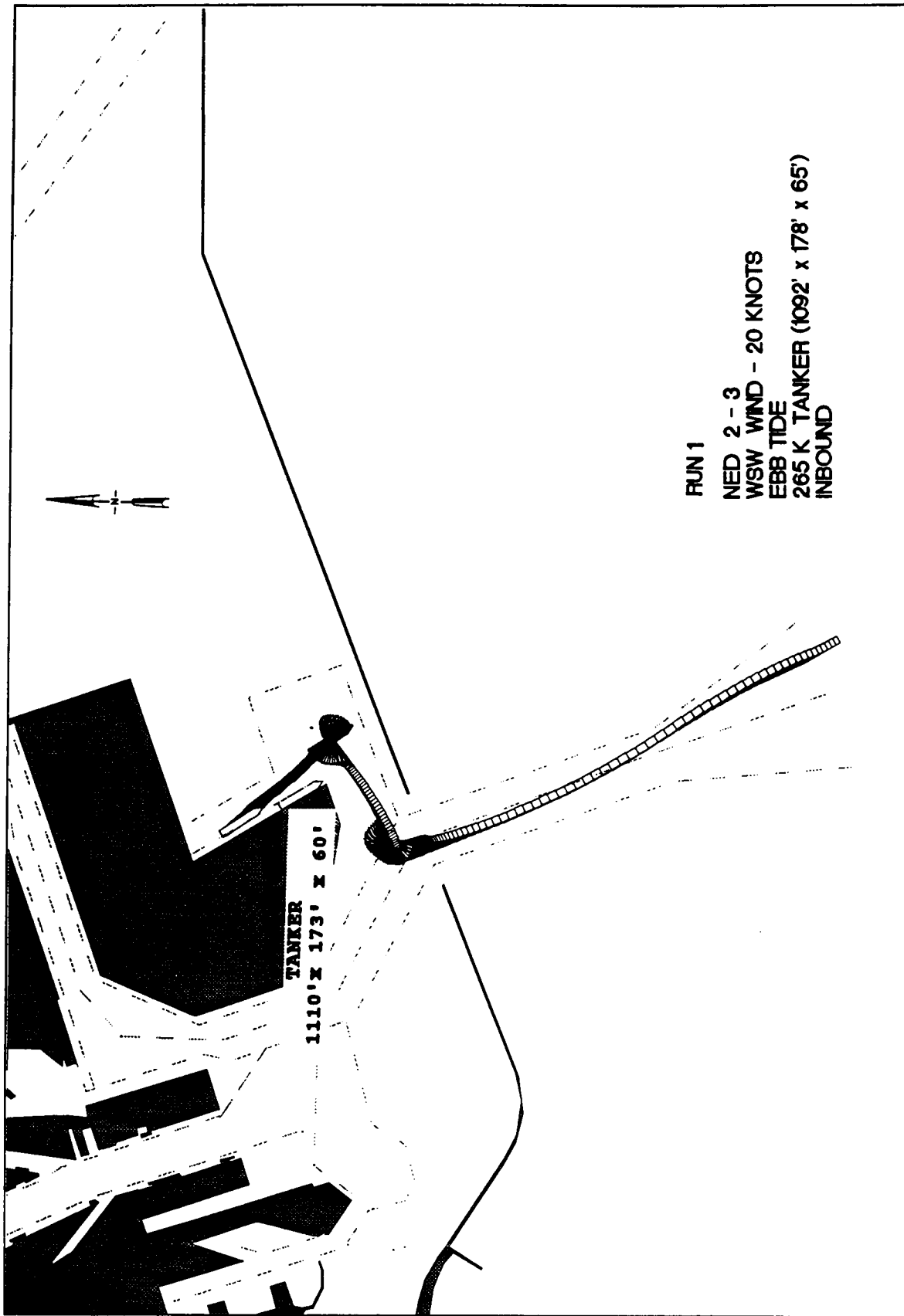
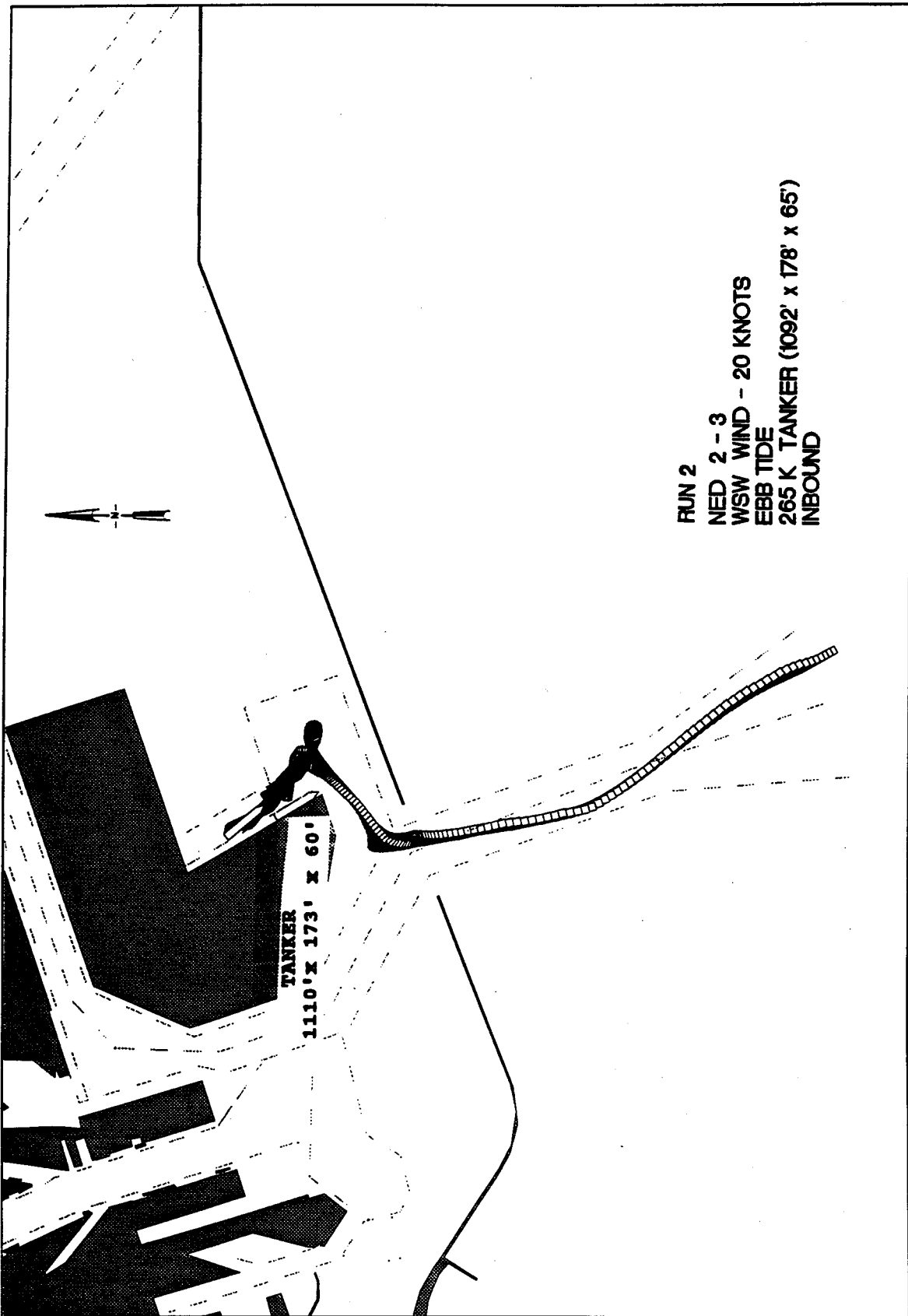

Plate 270



RUN 2  
NED 2-3  
WSW WIND - 20 KNOTS  
EBB TIDE  
265 K TANKER (1092' x 178' x 65')  
INBOUND

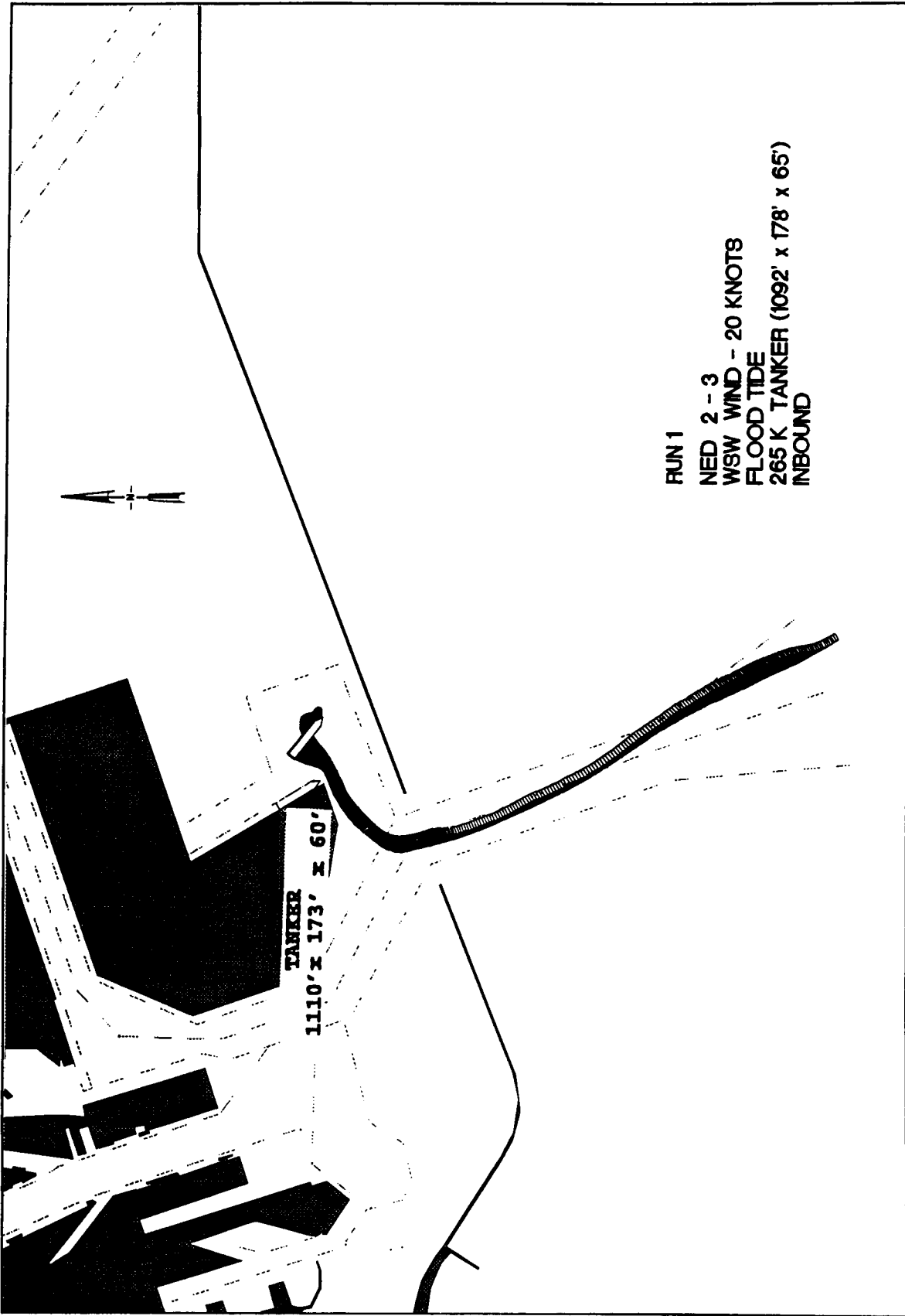
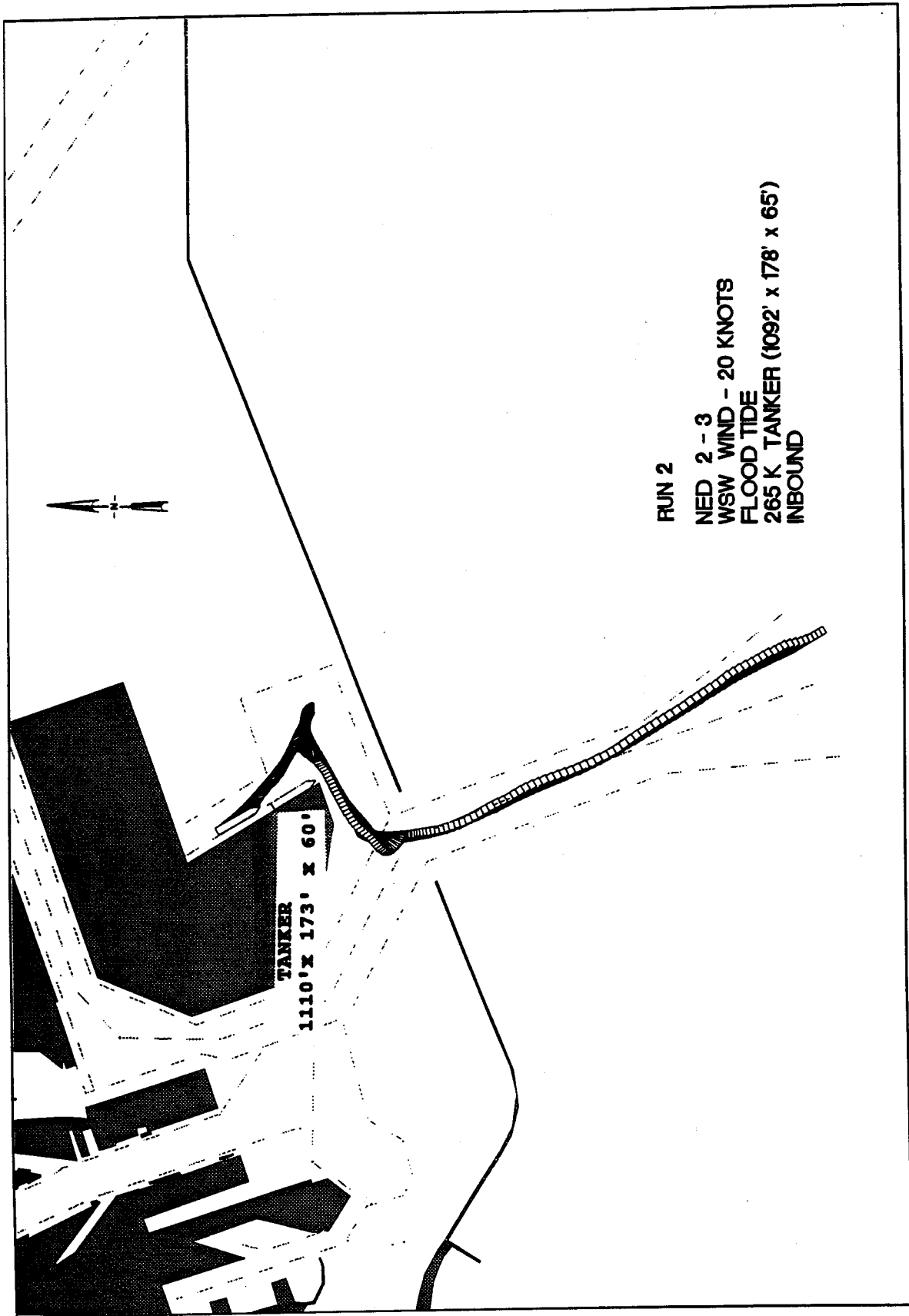
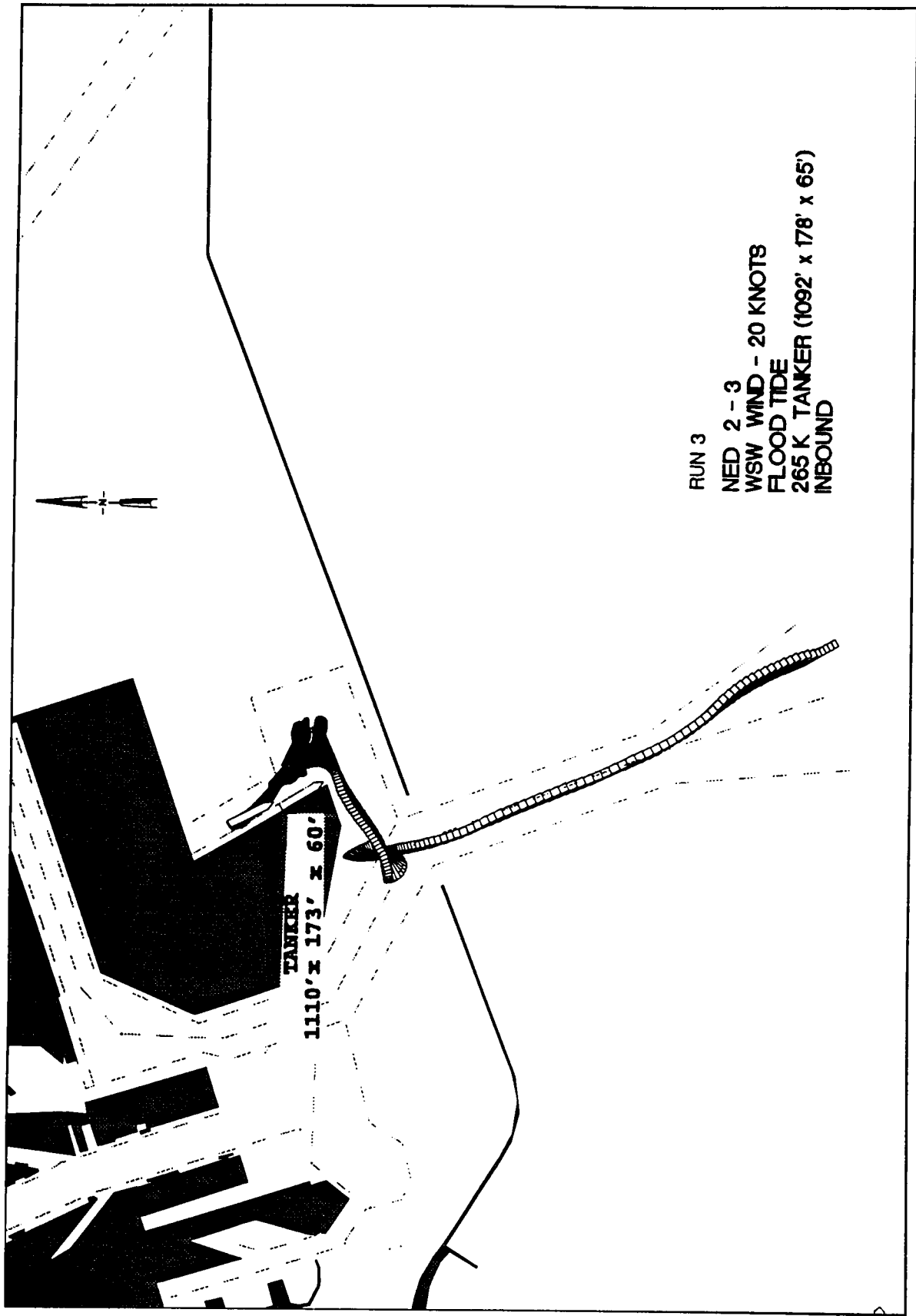

Plate 272



RUN 2  
NED 2 - 3  
WSW WIND - 20 KNOTS  
FLOOD TIDE  
265 K TANKER (1092' x 178' x 65')  
INBOUND

TANKER  
1110' x 173' x 60'



RUN 3  
NED 2-3  
WSW WIND - 20 KNOTS  
FLOOD TIDE  
265 K TANKER (1092' x 178' x 65')  
INBOUND

Plate 274

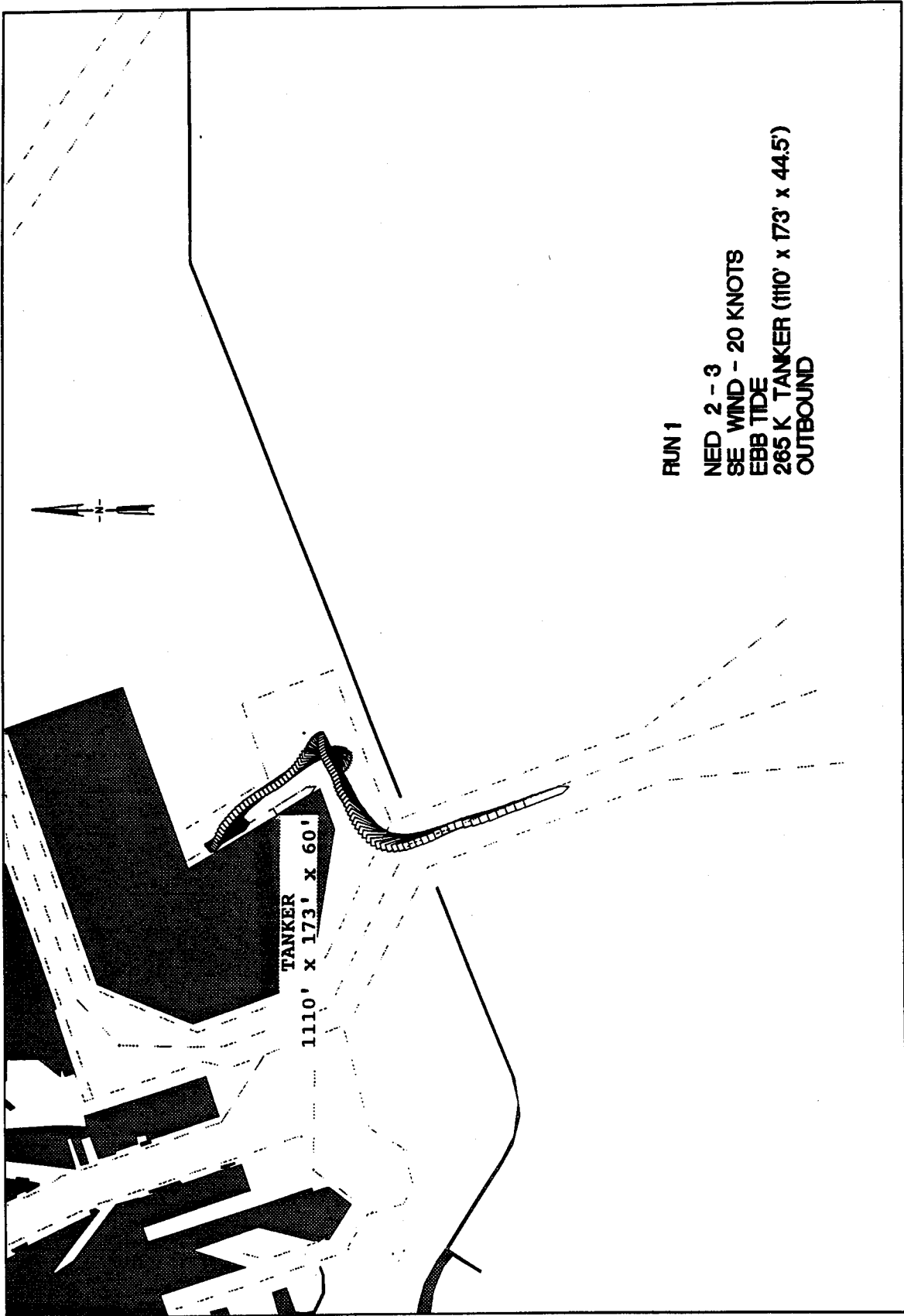

RUN 1

NED 2-3

SE WIND - 20 KNOTS

EBB TIDE

265 K TANKER (1110' x 173' x 44.5')

OUTBOUND

TANKER  
1110' x 173' x 60'

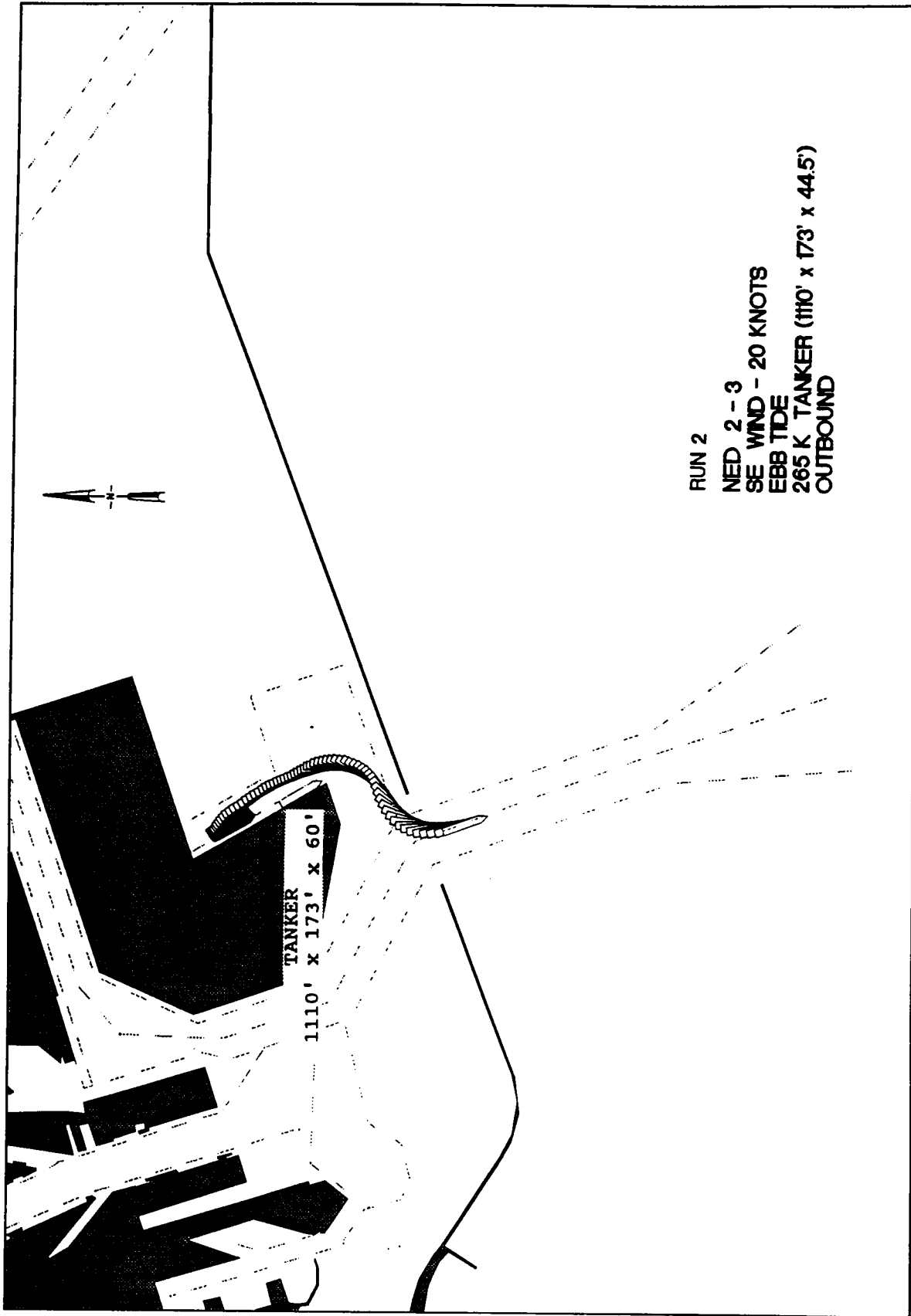

RUN 2  
NED 2-3  
SE WIND - 20 KNOTS  
EBB TIDE  
265 K TANKER (110' x 173' x 44.5')  
OUTBOUND

Plate 276

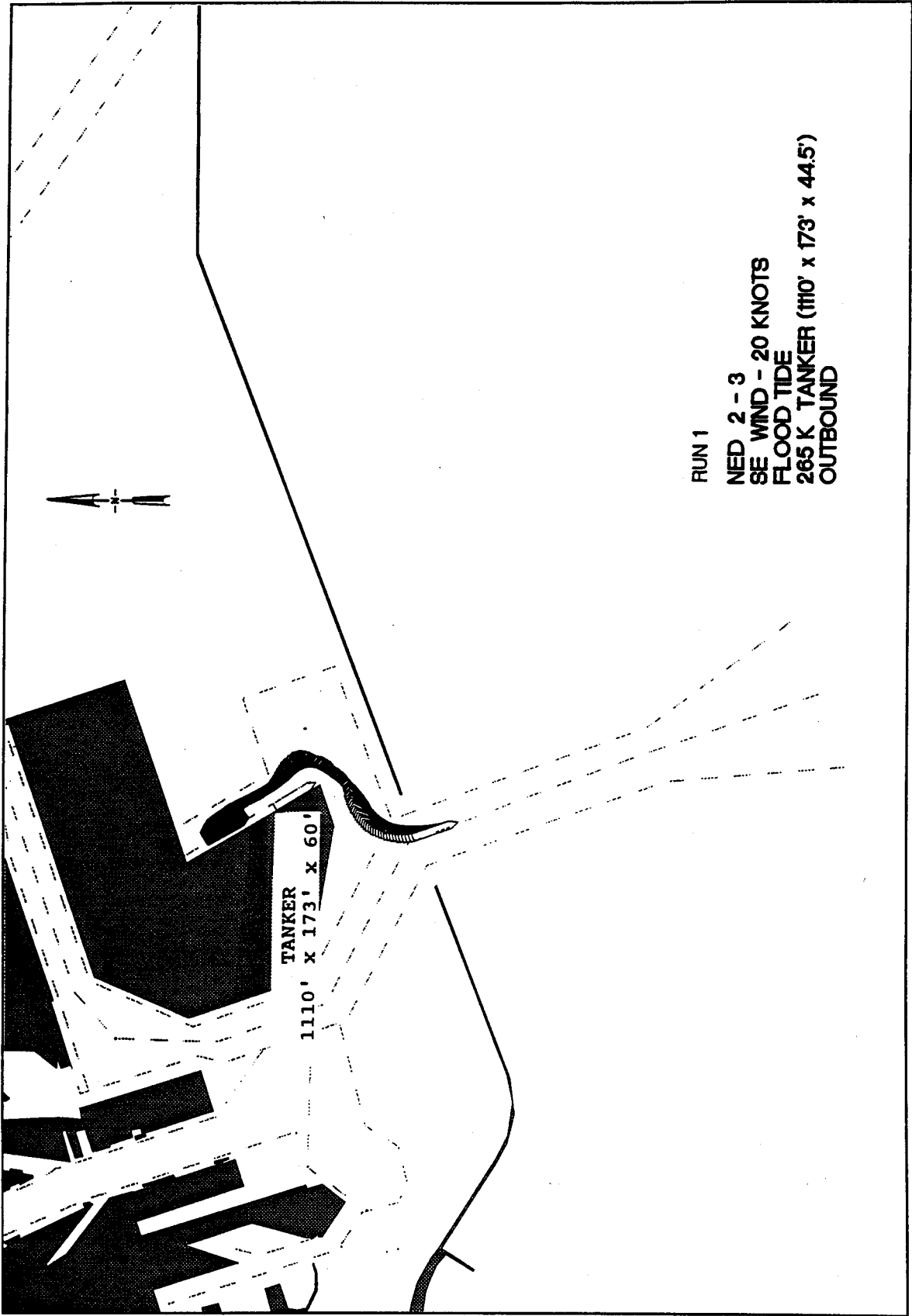

RUN 1  
NED 2 - 3  
SE WIND - 20 KNOTS  
FLOOD TIDE  
265 K TANKER (110' x 173' x 44.5')  
OUTBOUND

TANKER  
1110' x 173' x 60''

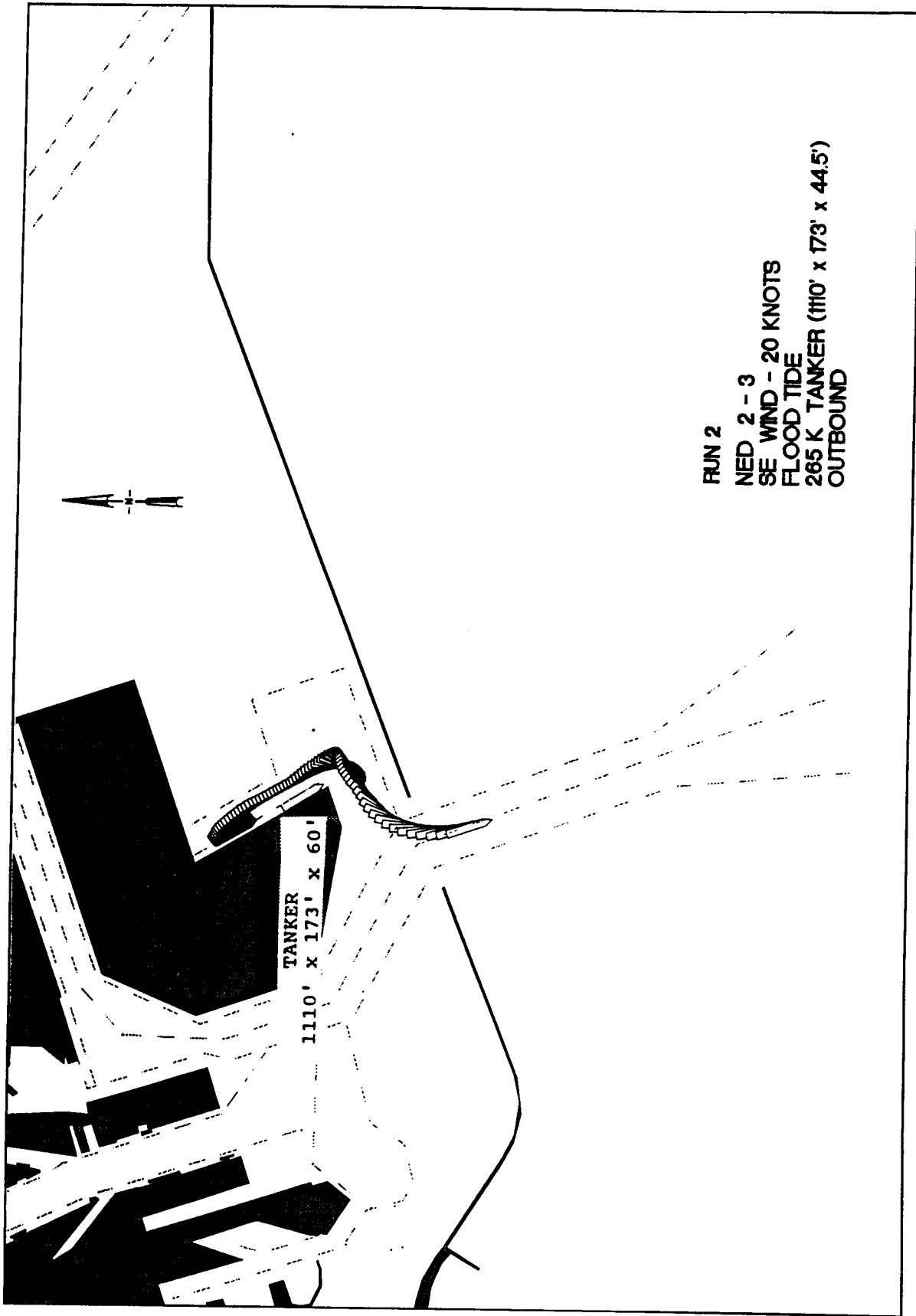

RUN 2  
NED 2 - 3  
SE WIND - 20 KNOTS  
FLOOD TIDE  
265 K TANKER (1110' x 173' x 44.5')  
OUTBOUND

Plate 278

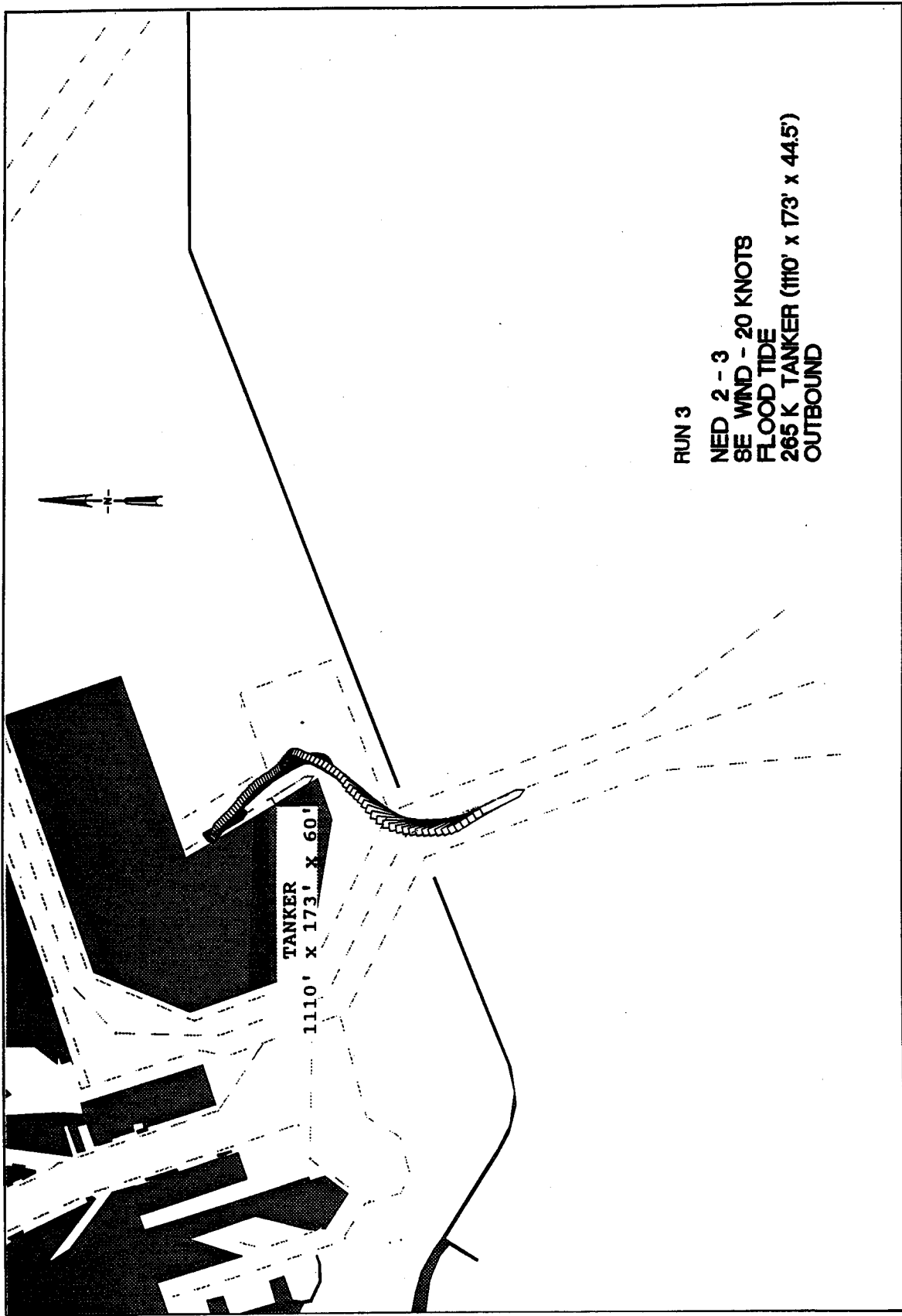

RUN 3  
NED 2 - 3  
SE WIND - 20 KNOTS  
FLOOD TIDE  
265 K TANKER (1110' x 173' x 44.5')  
OUTBOUND

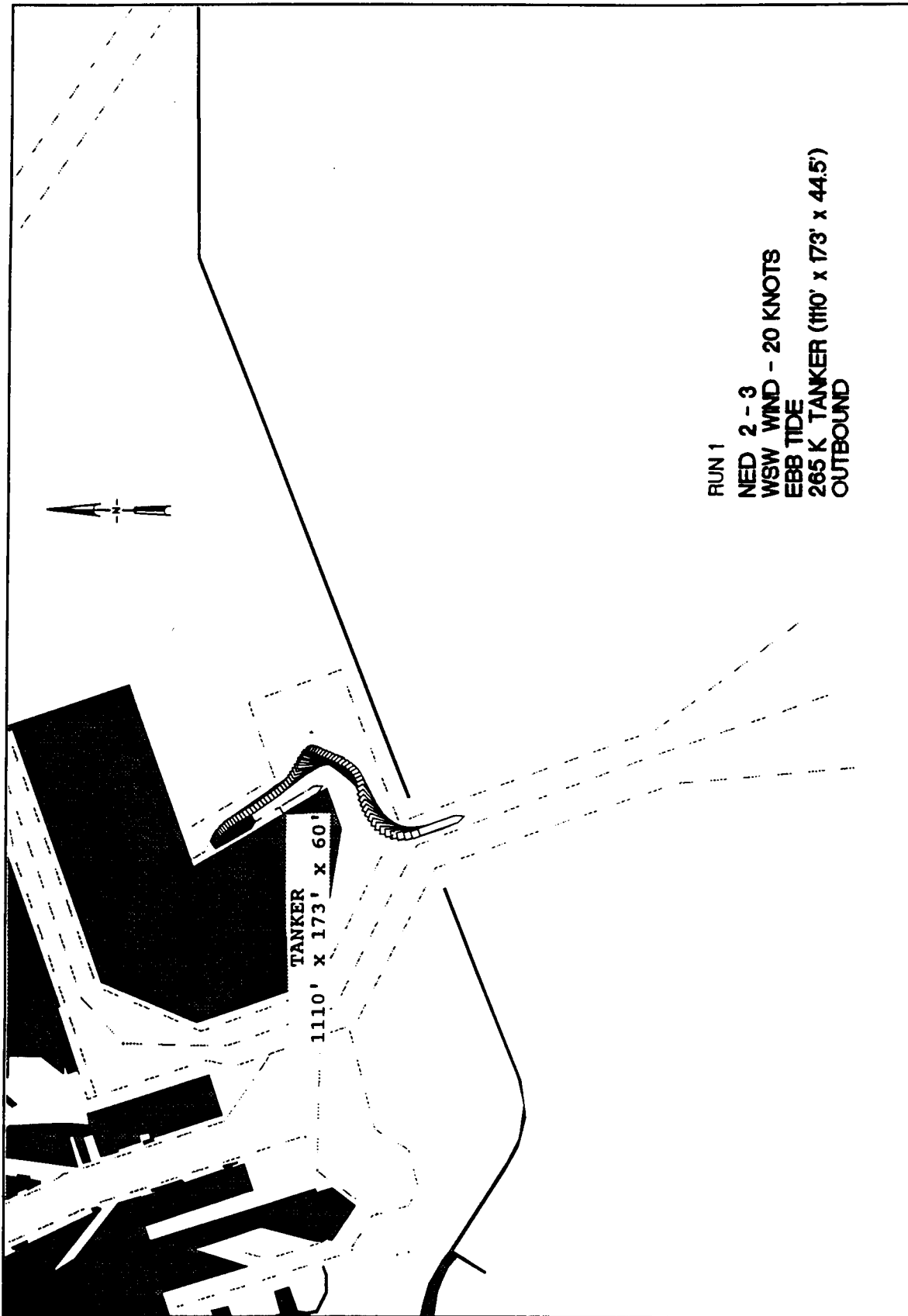
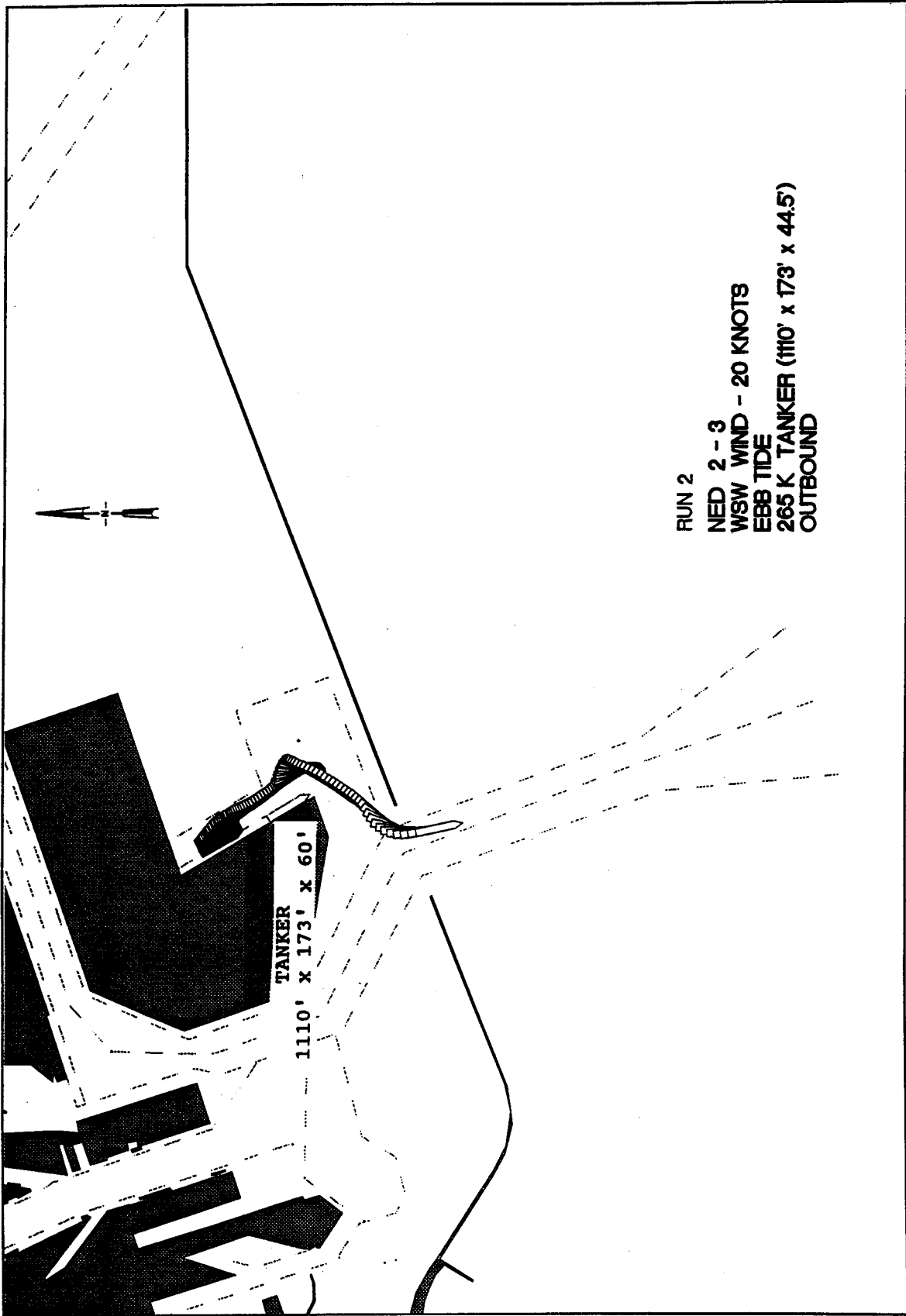

Plate 280



RUN 2  
NED 2-3  
WSW WIND - 20 KNOTS  
EBB TIDE  
265 K. TANKER (110' x 173' x 44.5')  
OUTBOUND

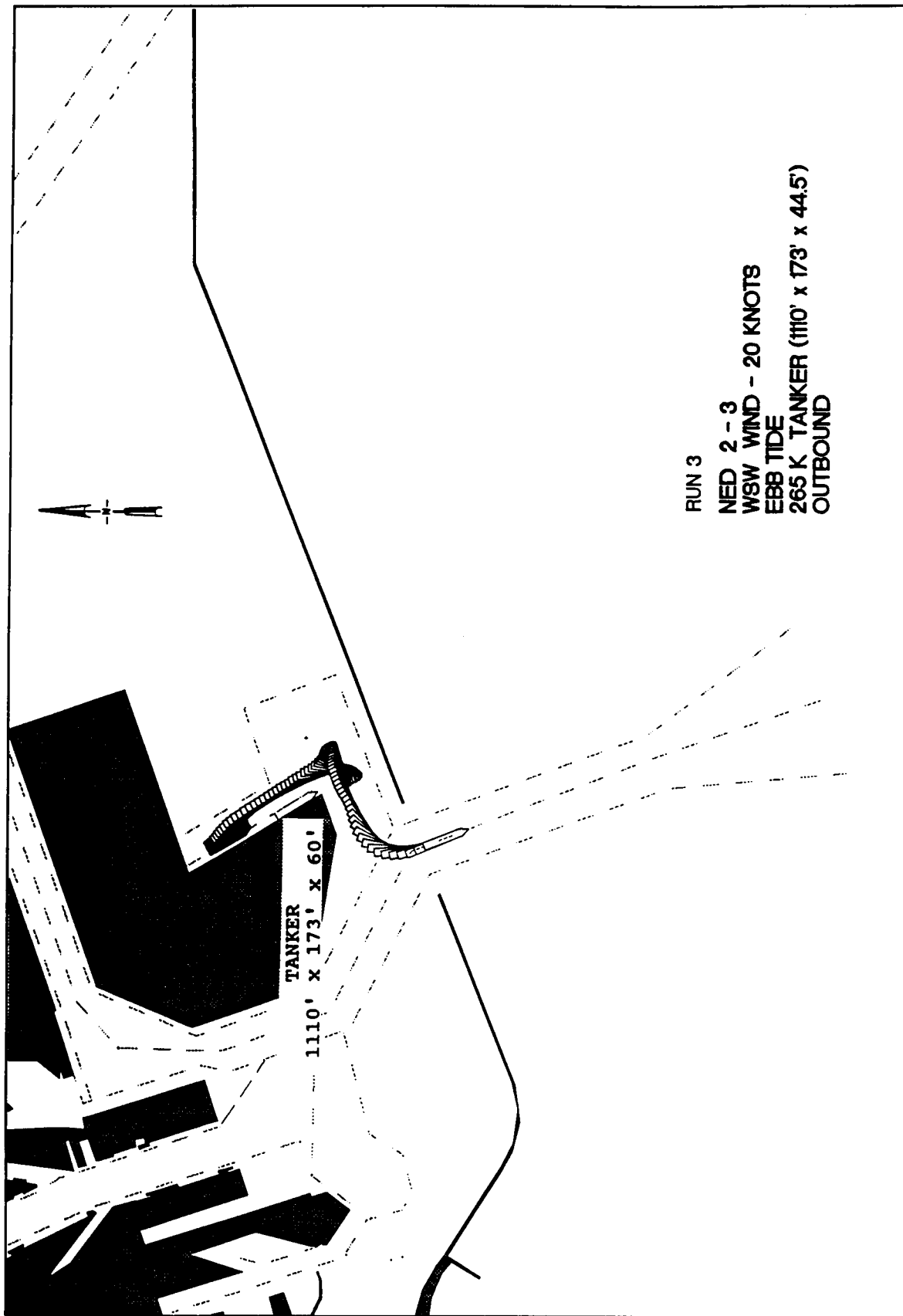
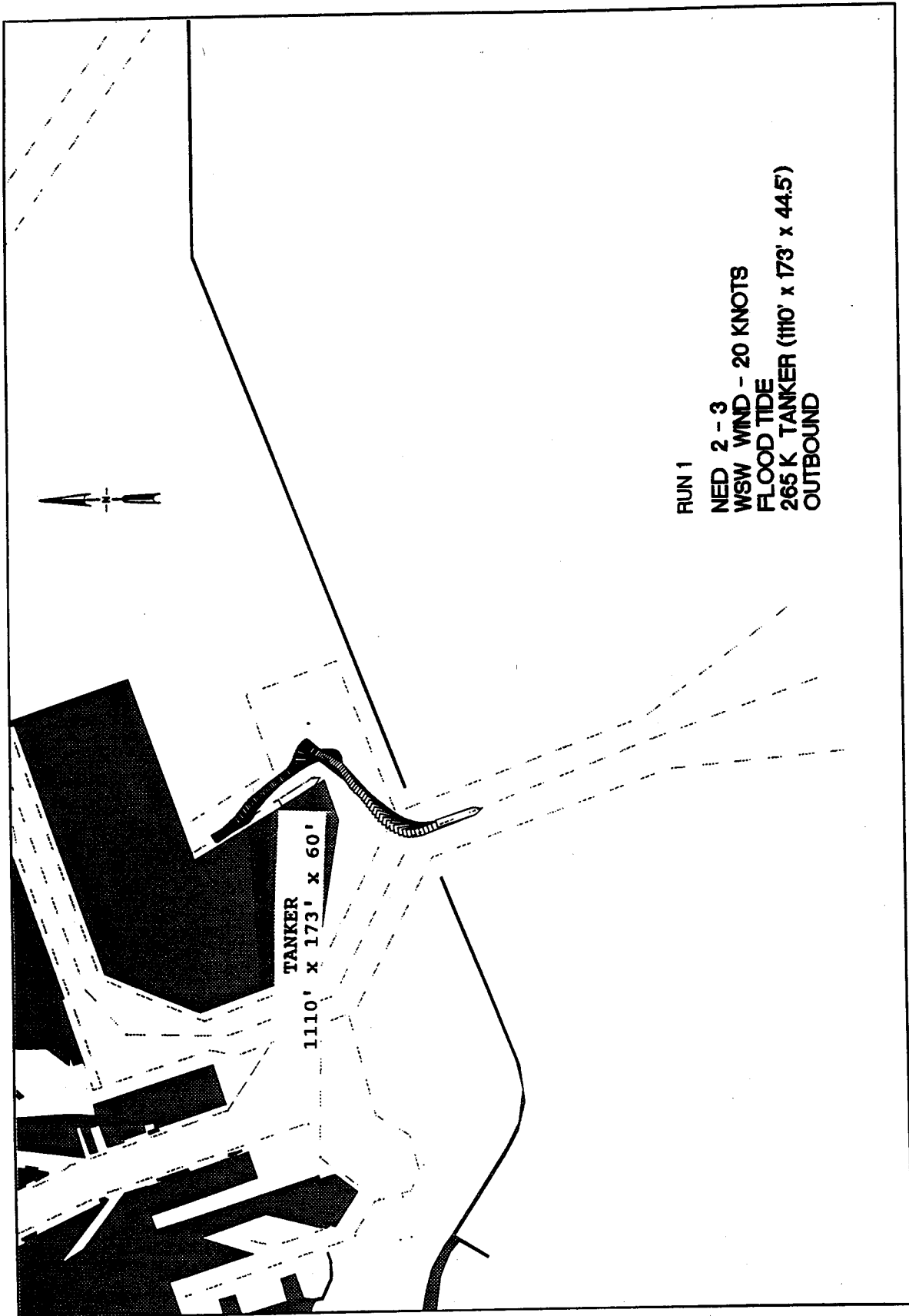

Plate 282



RUN 1  
NED 2-3  
WSW WIND - 20 KNOTS  
FLOOD TIDE  
265 K TANKER (110' x 173' x 44.5')  
OUTBOUND

TANKER  
1110' x 173' x 60''

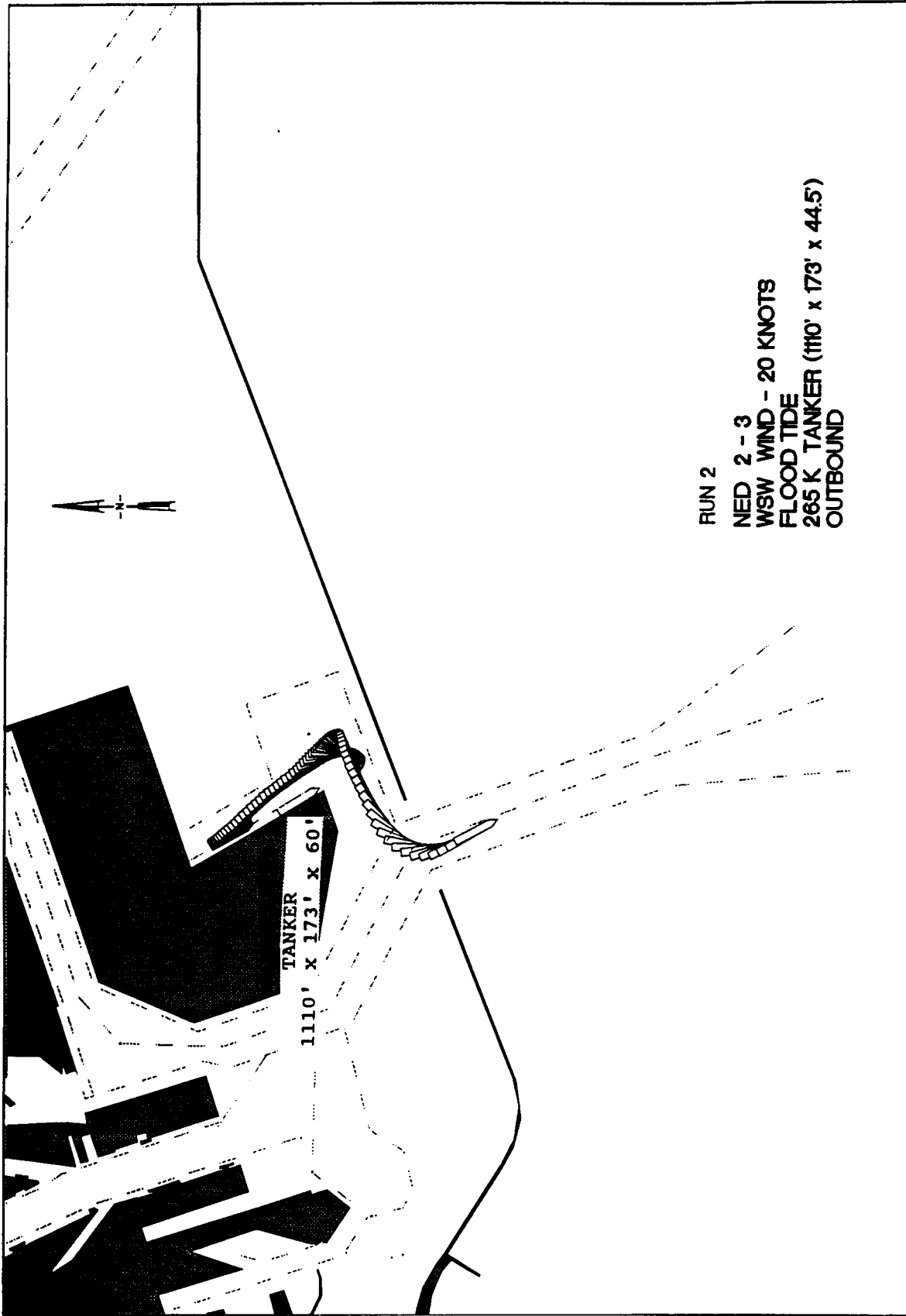
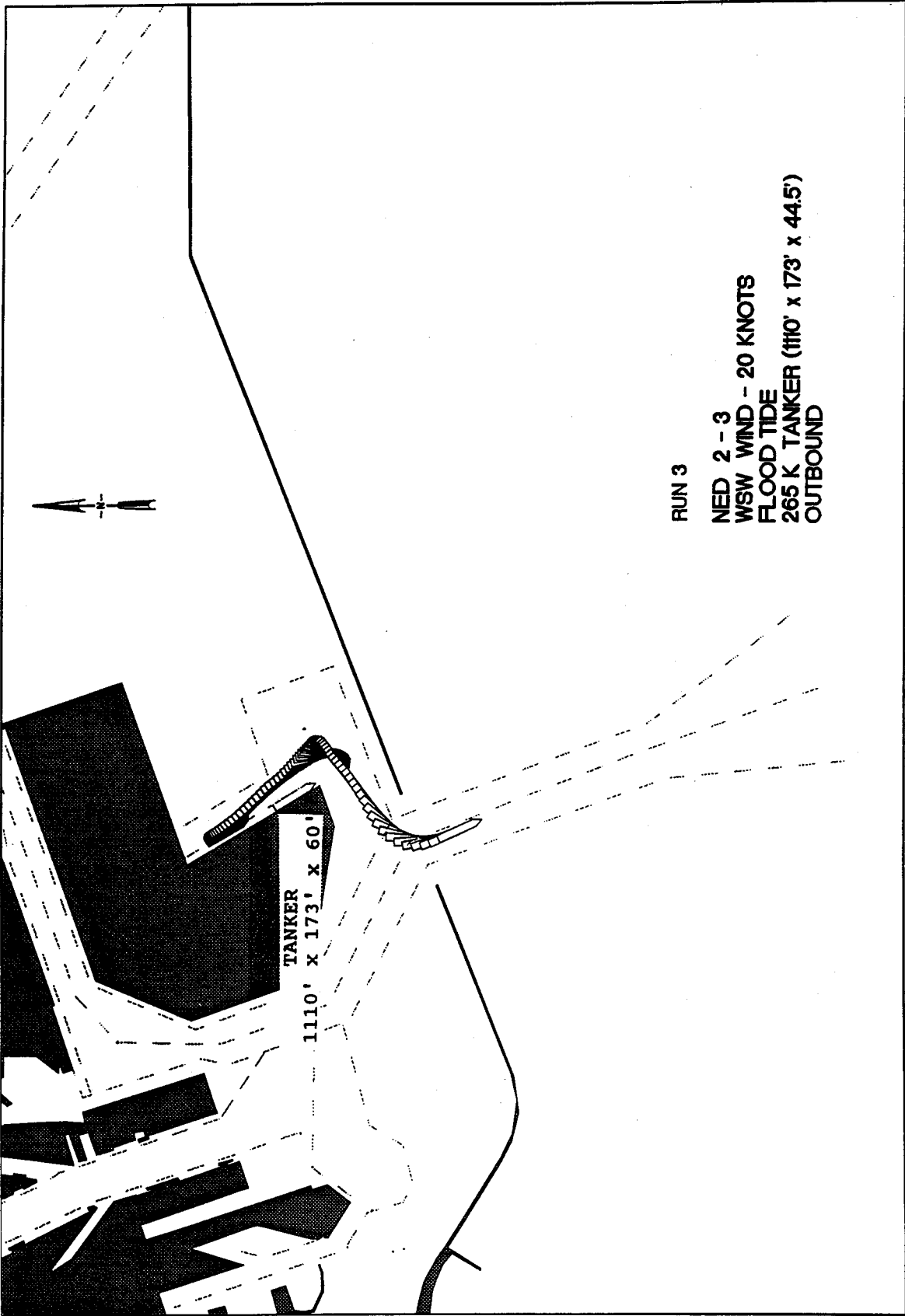

Plate 284



RUN 3  
NED 2 - 3  
WSW WIND - 20 KNOTS  
FLOOD TIDE  
265 K TANKER (1110' x 173' x 44.5')  
OUTBOUND

# Appendix A

## MSI Learning Center and Simulator Facility

---

### Learning Center

Marine Safety International's Shiphandling Learning Center is located in the Aquidneck Industrial Park in Middletown, Rhode Island, a 10 minute drive from the Newport Naval Base. The Center contains the simulator complex and the necessary support facilities which include classrooms, office space, student lounge, maintenance spaces, and computer room. The floor plan of the center is shown in Figure A1. The total area of the center is about 16,000 ft sq of which about half is occupied by the simulator complex and the immediate support spaces. The center is arranged so that the simulator functions are separated from the administrative and support functions.

As noted above, the simulator complex, developed in response to the requirements of the Navy and MSI, consists of four simulators—2-Visual Shiphandling Trainers (VST's), a Full Mission Bridge (FMB) Simulator and a Full Mission Bridge Wing Simulator (FMBW). These simulators may be operated independently or integrated together in a combined exercise. They all operate using the same mathematical models and databases. In general, the total software package is about 95 percent common between the four simulators. The following sections describe the simulators in more detail.

### Visual Shiphandling Trainer

Two Visual Shiphandling Trainers (VST's) are located at the center. Figure A2 presents an arrangement drawing of a VST. Each VST is located in a compartment approximately 26 x 16 ft with decor to give the feel of a ship's bridge. The major equipment in each VST includes:

- Ship control console
- 4 channel CGI visual system with a 180° x 30° field of view
- Pelorus

- Raytheon RACAS V radar display with ARDA
- Chart table with PMP and light
- Video situation display (VSD) with touch screen control
- Simulated VHF communications

The simulator operators area includes a terminal to control the simulator, monitors to display the visual scene and VSD, a printer, and a video hard copy device.

The design of the VST evolved from the original Navy requirement for a part task simulator with only a plan view and radar display. It was realized that a visual display would be of great value in meeting the training objectives. The design shown in Figure A2 was developed in response to this changed requirement. The two VST's became operational in January of 1987.

In functions and capabilities, the VST's are similar to the full mission simulator. They run the same math models and databases, and use the same computers and projection systems. The VST's differ from the full mission simulators in the following features:

- They require much less space.
- The field of view is only 180° x 30° and the distance to the screen is less.
- The students have direct control of tugs and moorings.
- Only one simulator operator is required for two VST's, but the simulator operator has no direct control of own ship.
- One learning feedback center supports both VST's.

The VST's have proven to be very effective in meeting the objectives established for them.

### **Full Mission Bridge Wing Simulator**

The Full Mission Bridge Wing (FMBW) simulator is unique. It provides a bridge wing environment with a correct visual display covering a field of view from 20° over the bow, through 220° to 20° over the stern in the horizontal plane and 15° up and 30° down for a total of 45° in the vertical plane. The arrangement of the FMBW simulator is shown in Figure A3. Appendix A provides additional discussions of the rationale and requirements associated with the FMBW.

The major equipment in the Bridge Wing Simulator includes:

- Bridge wing with displays
- 7 channel CGI visual system with 220° x 45° field of view
- Pelorus
- Raytheon 12 in. radar display

- Video situation display
- Simulated MC and VHF communications
- Sound system

A Learning Feedback Center (LFC) is associated with the FMBW Simulator. The LFC contains:

- Operator console with controls and displays
- 7 monitors to display visual scene channels
- Large screen projected display of video situation display
- Chart table
- T.V. monitoring of wing
- Hard copy device

The bridge wing is symmetric so that port or starboard is determined only by the screens upon which the bow and stern images are projected and the heading gyro-repeater in the pelorus. A forward view is also available which represents standing on an open bridge in front of the pilot house. The simulator operator can change the view from port to centerline to starboard wing in less than 5 seconds. This allows an exercise to start on one wing and change to the other wing as required by the scenarios.

The students on the bridge wing have control over own ship by conning orders communicated over the MC circuit to the simulator operator who in turn controls own ship from his console. Figure A4 shows the simulator operator console. The operator has direct control of own ship, moorings, tugs, and traffic ships as well as simulator functions (for example, viewing position, day, dusk, night, wind, current, etc.). The console displays include own ship parameters, video situation display with mouse control of functions, and simulator control menus.

### **Full Mission Bridge Simulator**

The Full Mission Bridge (FMB) simulator is the most conventional simulator at the center. It provides a full bridge environment with a CGI visual display covering a field of view of 220° horizontal by 45° (20 up - 25 down) vertical. The arrangement of the FMB is shown in Figure A5. The bridge itself is configured to represent a generic Navy bridge typical of a destroyer type vessel. The color and "decor" is typical of a Navy bridge rather than the more sterile "computer room" look of most simulator bridges.

The major equipment in the Full Mission Bridge includes:

- Pilot house
- 7 channel CGI visual system with 220° x 45° field of view
- Ship control console
- 2 chart tables with lights and PMP's
- Navigation displays
- 2 radar displays (Raytheon RACASIV ARPA and 16 in. display)

- Video situation display
- MC and VHF communications
- Sound system

A learning feedback center is associated with the FMB. It is identical to the LFC described above for the FMBW simulator. The only addition is a slave radar display.

The students on the bridge have direct control of all own ship functions. The simulator operator has control of tugs, moorings, and anchors as well as traffic ships and simulator functions. The operator also has the option of controlling all own ship functions from his control console. The simulator control console itself is identical to the one in the bridge wing simulator.

## System Capabilities

As noted, the system capabilities of the four simulators at the center are essentially identical. Table A1 presents a summary of these capabilities.

At the present time, the simulator complex has available 9 different classes of naval vessels including combatants (DD963, FFG7, FF1052), large auxiliaries (AFS, AOR, T-AO), and special craft (LST, MCM, ARS). Additional naval or commercial vessels can be added as desired. Databases are available for open sea, 3 generic ports used for training, and Hampton Roads. Additional ports can be added and a highly interactive model data input station was provided with the simulator complex.

## Learning Feedback

The simulator complex has a number of features which were specifically included for learning feedback purposes. Each of the simulators has a specific area for learning feedback. These Learning Feedback Centers (LFC's) are equipped with monitors displaying the visual scene, large screen projection of the video situation display (VSD), monitor and audio system to observe activities on the bridge or bridge wing, and printout and video hard copy devices. The simulator software has a number of features to allow the use of the LFC equipment and displays. These include:

- Complete record of own ship and traffic ship histories.
- Freeze and reply modes for the simulator.
- Feedback features on the video situation display including track history and prediction.
- Parameter plots of significant variables.

**Table A1  
Simulator System Capabilities**

|   |  |  |
|---|--|--|
| 1 | 3 DOF mathematical models valid for zero and all speeds, large drift angles, and shallow water |  |
| 2 | Ship controls  | Single and twin screw  |
|   |  | Fixed and CRP propellers   |
|   |  | Thrusters  |
|   |  | Steam, diesel, and gas turbine machinery   |
| 3 | External effects   | Moorings   |
|   |  | Anchors  |
|   |  | Tugs   |
|   |  | Fenders  |
| 4 | Radar simulation   | Digital target generation  |
|   |  | Digital landmass generation  |
|   |  | Actual radar displays (some with ARPA)   |
| 5 | Environment  | Variable water depth   |
|   |  | Current  |
|   |  | Wind   |
|   |  | Wave drift   |
|   |  | Banks  |
|   |  | Ship-ship interaction  |
| 6 | Traffic ships  | Up to 10 active at one time  |
|   |  | 2, 3, or 4 simulators may interact   |
| 7 | Visual scene   | CGI image generation   |
|   |  | Day, dusk, night, fog  |
|   |  | Open sea or restricted water   |
|   |  | Up to 10 moving traffic ships  |
|   |  | Special effects:<br>Waves<br>Own ship and traffic ship wakes<br>Mooring and distance lines<br>Special lights |

The replay feature is very complete. The replay includes all displays and indicators including the VSD and visual system. The instructor may replay all or part of an exercise at rates of up to 10 times real time. A replay may progress to a selected point and then be continued as a new exercise in real time.

In addition to the LFC's associated with the simulators, the center contains conventional classrooms with extensive audio/visual equipment.

## **Simulator Operational Features**

The operator interfaces for each of the simulators have been kept almost identical. The interface is through a CRT terminal using an interactive user-friendly menu system. This menu system allows the simulator operator access and control of all simulator functions including system startup and shutdown, generation and selection of exercises and initial conditions, control of simulator functions, replays and housekeeping of files. The operator is never required to interact directly with the computer operating system. On-line help screens are available for each menu.

Exercises are created in advance and up to 999 may be stored on-line. Exercises are created through a series of menus which control the selection of own ship geographic area, initial position, heading, etc.; traffic ships; environment; moorings; tugs; etc. Once created, an exercise may be reused as often as desired. To run a simulation, the operator has only to call the "run" menu, select an exercise and add any desired notes specific to that run. About two minutes are required for the system to load initial conditions and databases at which time the simulator is up and running.

During an exercise, the operator controls environmental conditions, traffic ships if they are not under pre-programmed control, and communications. In the Bridge Wing the operator must also control own ship. In an exercise that requires a lot of activity from traffic ships, two operators may be required for the Bridge Wing. During an exercise, the operator may also make hard copy plots of the VSD for learning feedback purposes.

At the end of an exercise, the operator may start a new exercise or replay all or portions of a previous exercise as desired.

## **Computer System**

The simulator complex uses a distributed processing architecture with the computational resources linked together with a local area network. The system includes 3 DEC MICROVAX II systems for simulation management and hydrodynamic calculations, 27 Silicon Graphics IRIS computers for the visual scene generation, 8 PDP 11's for the radar simulation, and assorted microprocessors for the real time interfaces to bridge equipment. The systems

are linked together using an Ethernet local area network employing the TCP/IP protocol. The network configuration is shown in Figure A6. A single network is used so that the simulator can be run in an interactive mode if desired.

The total processing power of the complete computer system is about 60 MIPS. Database files are stored locally where they are used (i.e., exercise and hydrodynamic databases on the VAX's, visual databases on the Silicon Graphics, and radar landmasses on the PDP's). However, new files or backup files may be loaded on one system and then distributed around the network as necessary. The VAX system and selected Silicon Graphics systems have tape drives for backup purposes.

## Summary and Future Applications

The Marine Safety International Shiphandling Training Center at Newport, RI is now operational. This center contains a complex of four simulators each of which include new or unique features. The most significant of these consist of:

- The first Full Mission Bridge Wing Simulator.
- Four visual shiphandling simulators that may interact with each other in combined exercises.
- Large vertical and horizontal fields of view in the visual system.
- Complete mathematical models for a large number of operational Naval vessels.
- Extensive learning feedback features.

## Full Mission Bridge Wing Concept From the Mariner's Viewpoint

### Technical considerations

All shiphandling simulators in the world today are so arranged that the preferred viewing point is located on the ships' centerline in the wheelhouse. The place at which the shiphandling trainee obtains the necessary view for maneuvering decisions is on the ship's centerline and usually near the middle of the bridge. This position is good for training in bridge watchkeeping, some harbor entry, and channel keeping. But this is not the position used by most conning officers, pilots, and docking masters when doing *shiphandling* (docking, undocking, lightering, lock approaches, underway replenishment, etc.). During these tasks, most shiphandlers work on the bridge wing. When on the wing, the shiphandler is away from the ship's centerline and near the ship's side.

Wings have been added to many standard simulators which have the bridge centerline as the center of the visual system, but this has only complicated the problem. The shiphandling trainee who walks out onto such a "wing" does

not get the view he thinks he will get since the geometry of the theater is for the bridge centerline observer. The person on the so-called wing is merely seeing the same "picture" as the centerline observer, but at a poor angle. His view is therefore distorted and not correct for making shiphandling decisions. Obviously, the "bridge" should be placed in the theater so that the wing location is at the preferred viewing point. Almost all close shiphandling is done from this wing location. A shiphandling simulator must have a wing location which provides a correct view for the trainee who is attempting to build shiphandling judgement.

Both the *fidelity* and the *accuracy* of the projected visual image must be considered. *Fidelity* is defined as the true-to-life quality of the image. Good fidelity means not only that the picture looks real and not too "cartoonish," but that the relative sizes and relationships of depicted objects appear life-like and not distorted. Good fidelity means, for example, that the ship being approached during an UNREP exercise has a proper aspect, does not look stretched or foreshortened, and appears to the experienced eye to be the right size for the distance it is from the observer.

*Accuracy* has to do primarily with correct angular relationships; that is, that the delivery ship referred to in the example mentioned above subtends the correct angle in the eye of the observer, and that, for instance, a visual bearing taken from a gyro-repeater to the stern of the ship being approached must be as accurate as in the real world.

In a conventional projection system of the type now used for shiphandling simulators, these two items (fidelity and accuracy) are achieved only at the center of the theater. Imagine for a moment that only the screens, projectors, and image generation equipment are in place. The entire projection theater has been constructed, but the pilot house and/or wing structure has not yet been erected. An observer is standing on the platform which will eventually support the pilot house. With no structure around him, he calls for the projection system to be turned on. The image he sees first is what the conning officer/trainee will see when standing on the centerline in the pilot house. Now our imaginary observer walks across the platform of the theater to the position at which he thinks the simulated bridge wing will be located. He complains that the picture is not right. There is a parallax error because he is off the ship's centerline. He asks the simulator operator to bias the computer generated image so that the transformation calculations are made not from the centerline location of the pilot house, but from the bridge wing location which might be 20, 30, or more feet from the first position, depending on the ship type.

The picture on the screen in the theater changes. The observer at first feels he is looking at a picture that has the qualities of fidelity and accuracy and is being generated from the wing location. Soon, however, he again recognizes a parallax error similar to the one he saw when the system was generating the scene as from the ship's centerline! He walks back to the center of the platform in the projection theater. Back at the center of the projection system the observer realizes he is seeing the "wing scene" in an aspect that shows

good size and angular relationships *and also* presents accurate bearings. It is at the *center* of the projection theater that the wing picture is correct. If the pilot house with wings structure had been built on the platform, the correct wing picture would not have been seen out on the wing mock-up, but from within the pilot house at the same physical place the centerline scene was observed. In this instance, the shiphandling trainee in the pilot house would have a better (i.e., more faithful and accurate) "wing view" than the shiphandling trainee standing on the so-called wing.

### **Training Considerations**

The separate bridge wing theater solves the projection problem and provides real, additional training benefits besides. First, all bearings taken from the wing repeater can be true bearings and accurate without distorting the visual image. This is a very important consideration for simulator exercises such as berthing, underway replenishment, and collision assessment.

The separate wing theater can be either the port or starboard wing since the image can be rotated around its center point with no visual penalty. This is important because now the pilot house in the centerline theater can be larger than if two wings were to be added, one on each side. The theater defines the size limit of the pilot house. A more life-like pilot house can be achieved if all the allowable room can be used without having to save some space for the wings. Moreover, the wing itself can also be larger for the same reason, providing room for all trainees and instructor as well.

Finally, the FMBW adds a training station to the learning center. By breaking the ship maneuvering tasks between those performed best in the pilot house and those performed best on the bridge wing, training through-put can be increased. One training team can be on the FMB at the same time another team is on the FMBW.

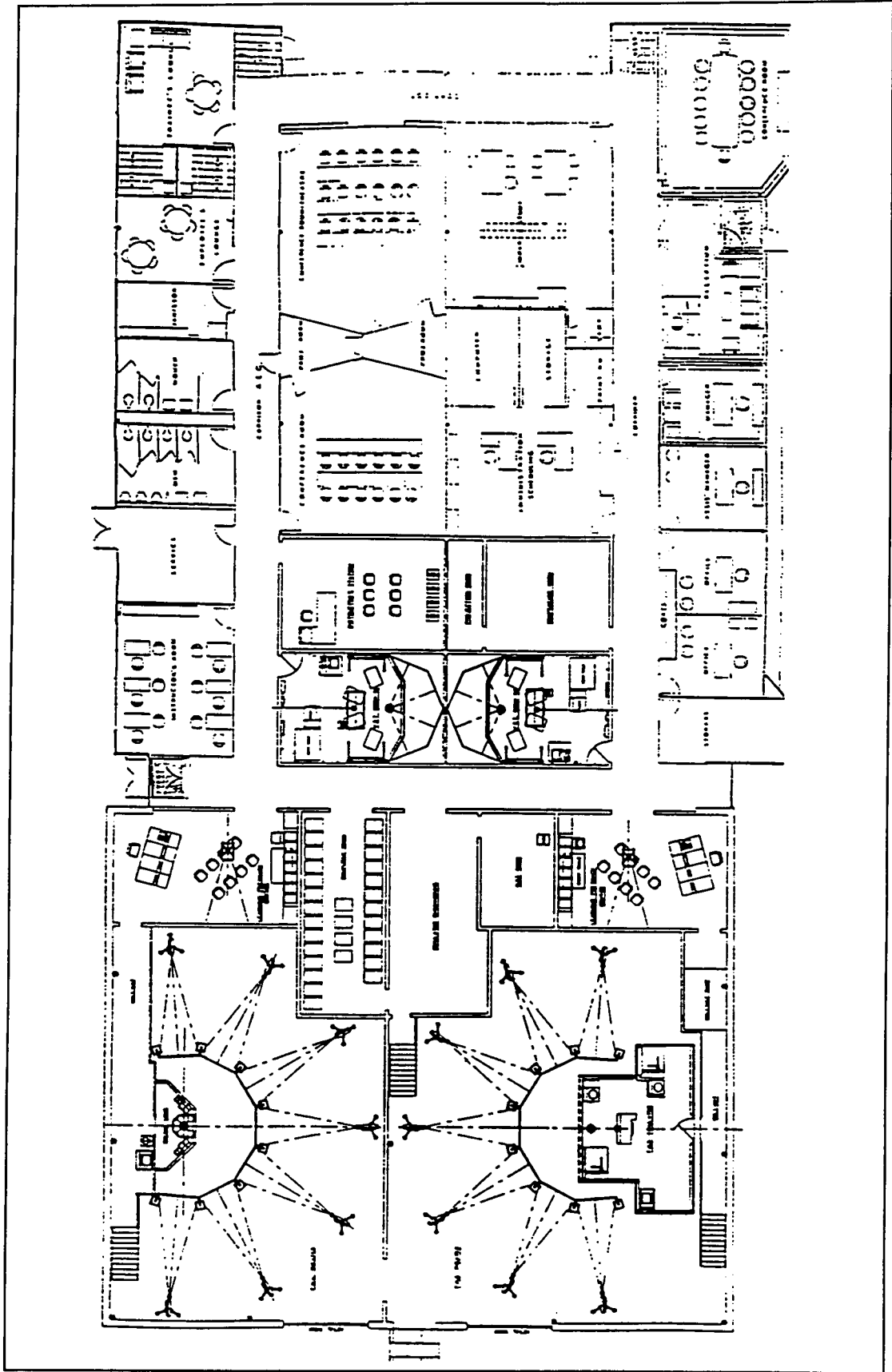

Figure A1. Learning Center floor plan

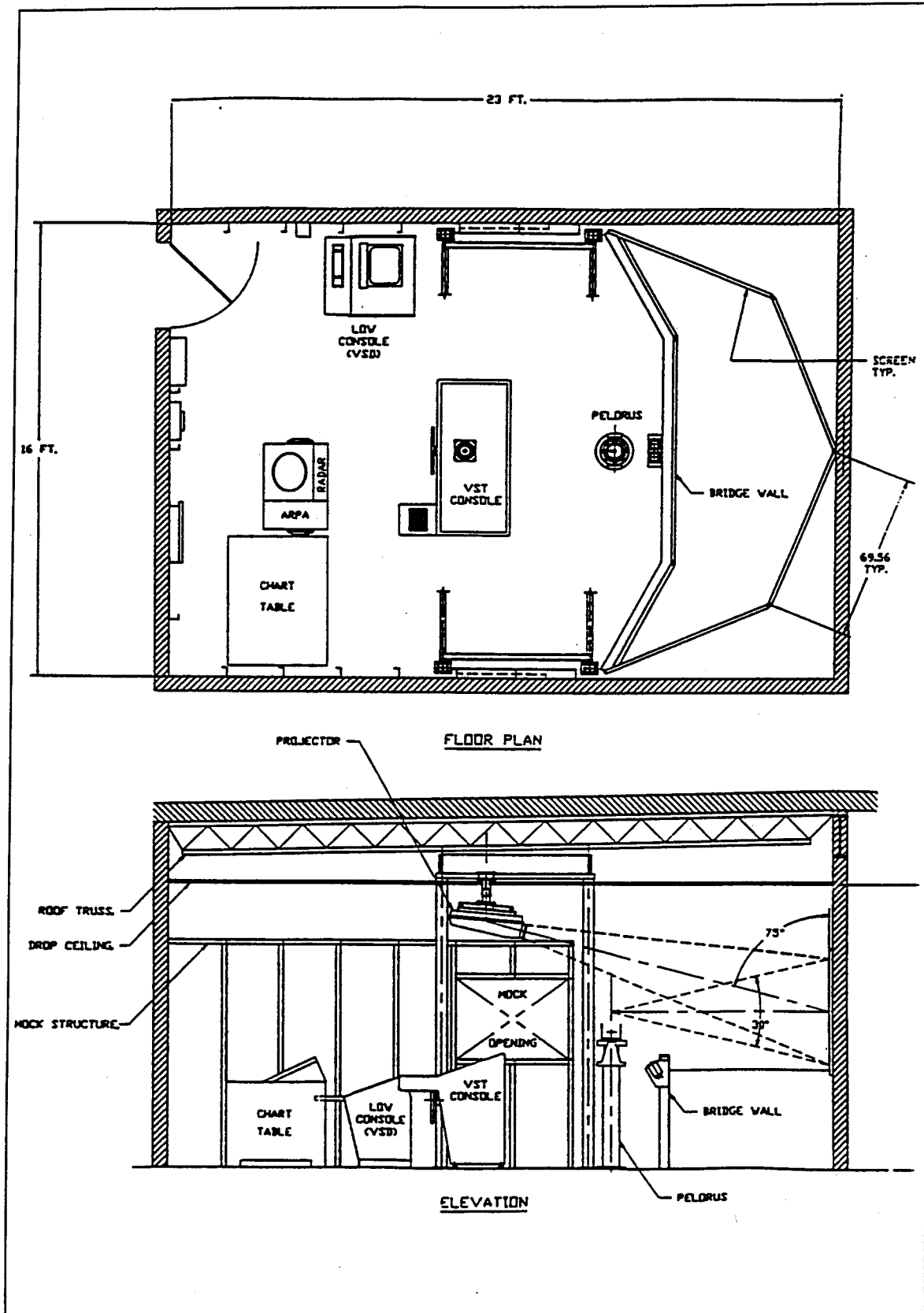

Figure A2. Arrangement of visual shiphandling trainer

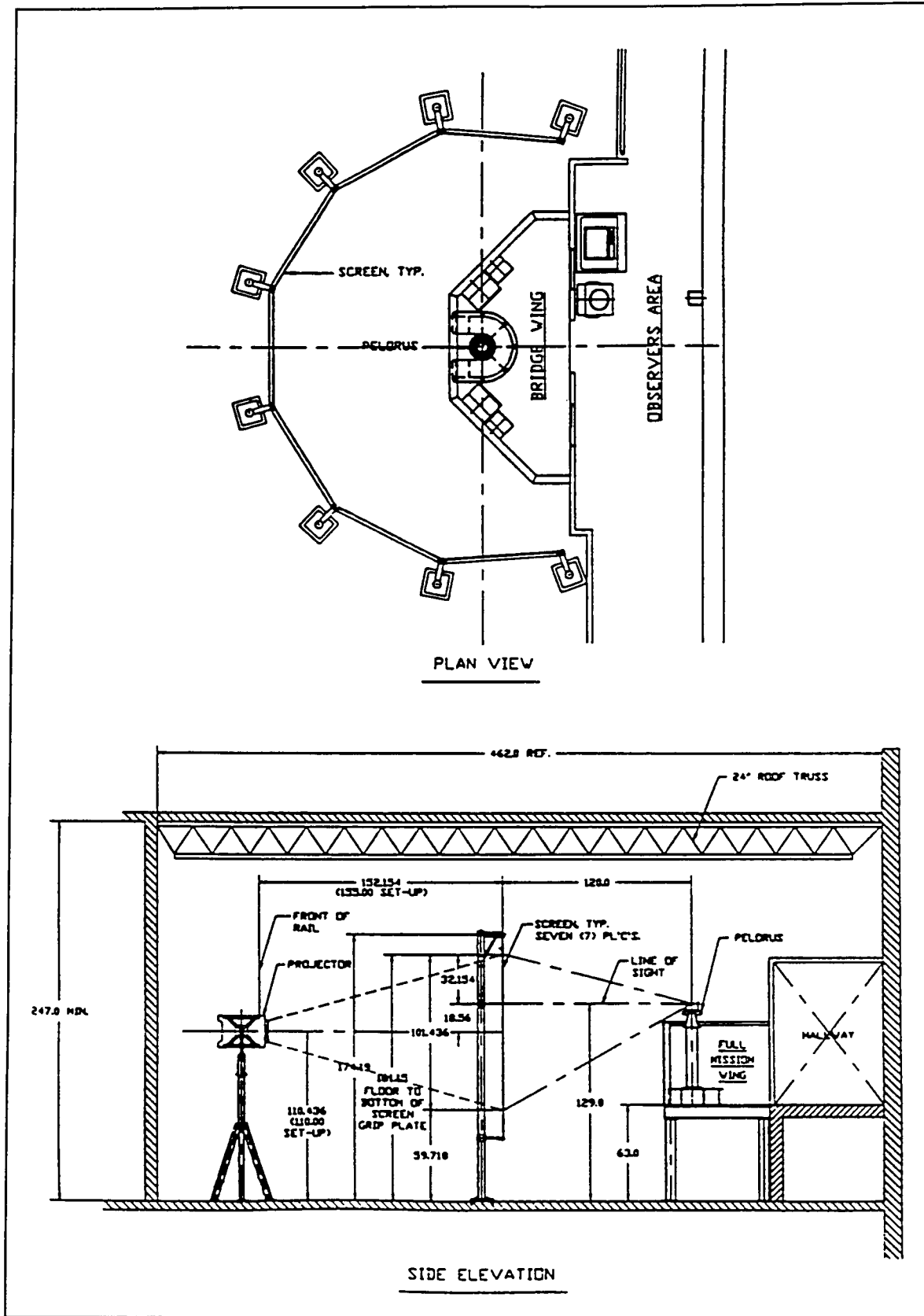

Figure A3. Arrangement of Full Mission Bridge Wing simulation

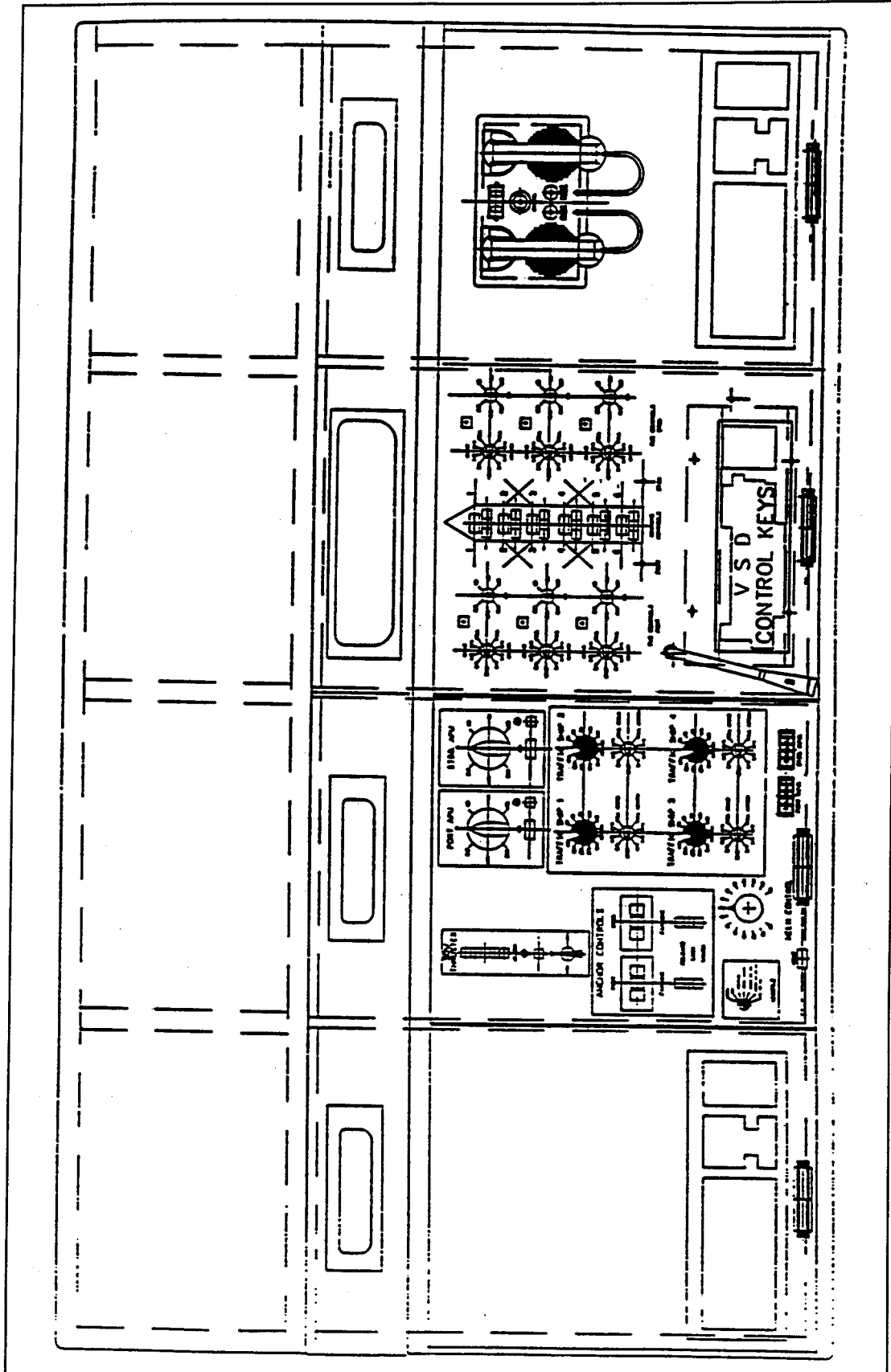

Figure A4. Simulator operators console

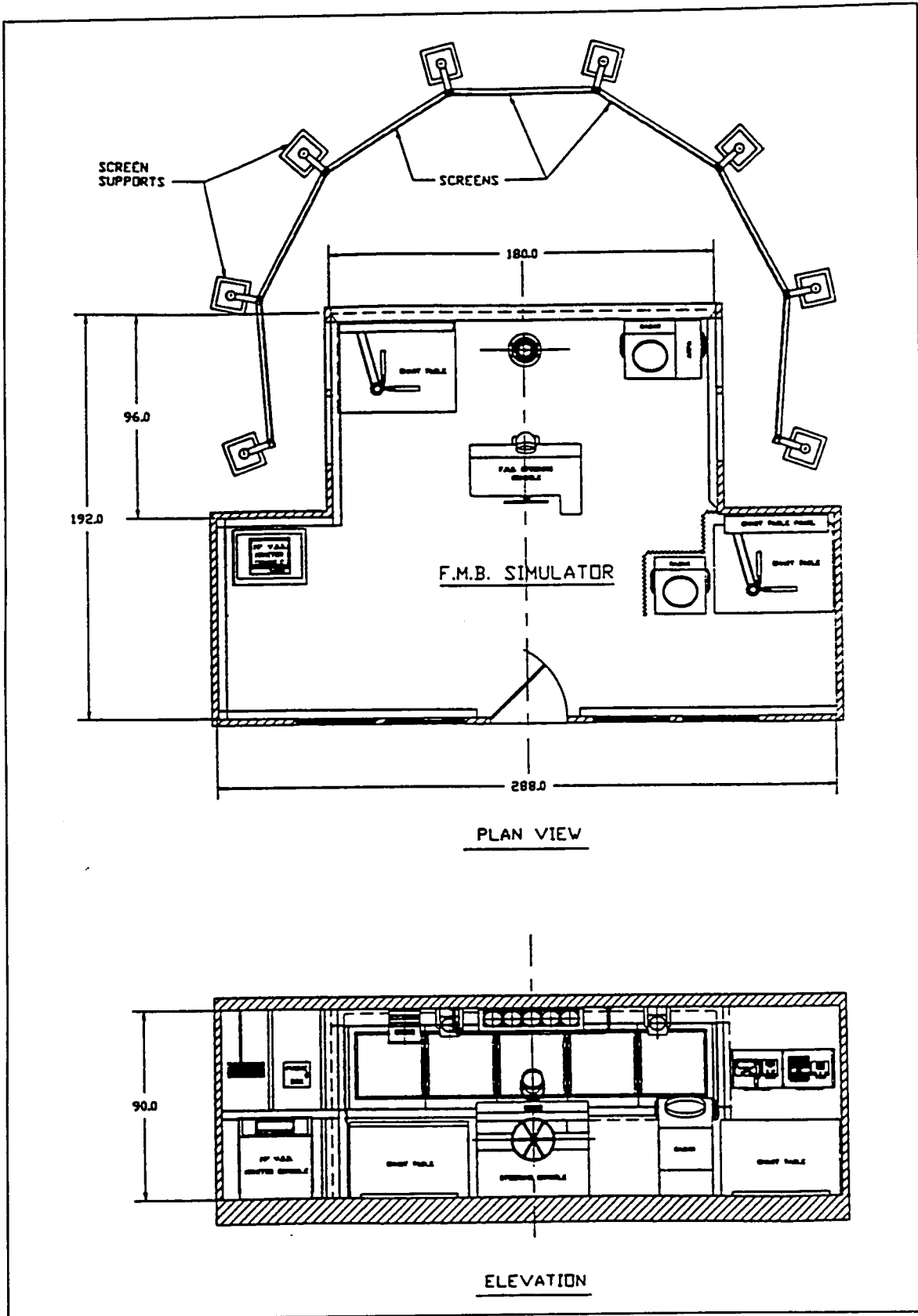

Figure A5. Arrangement of Full Mission Bridge simulator

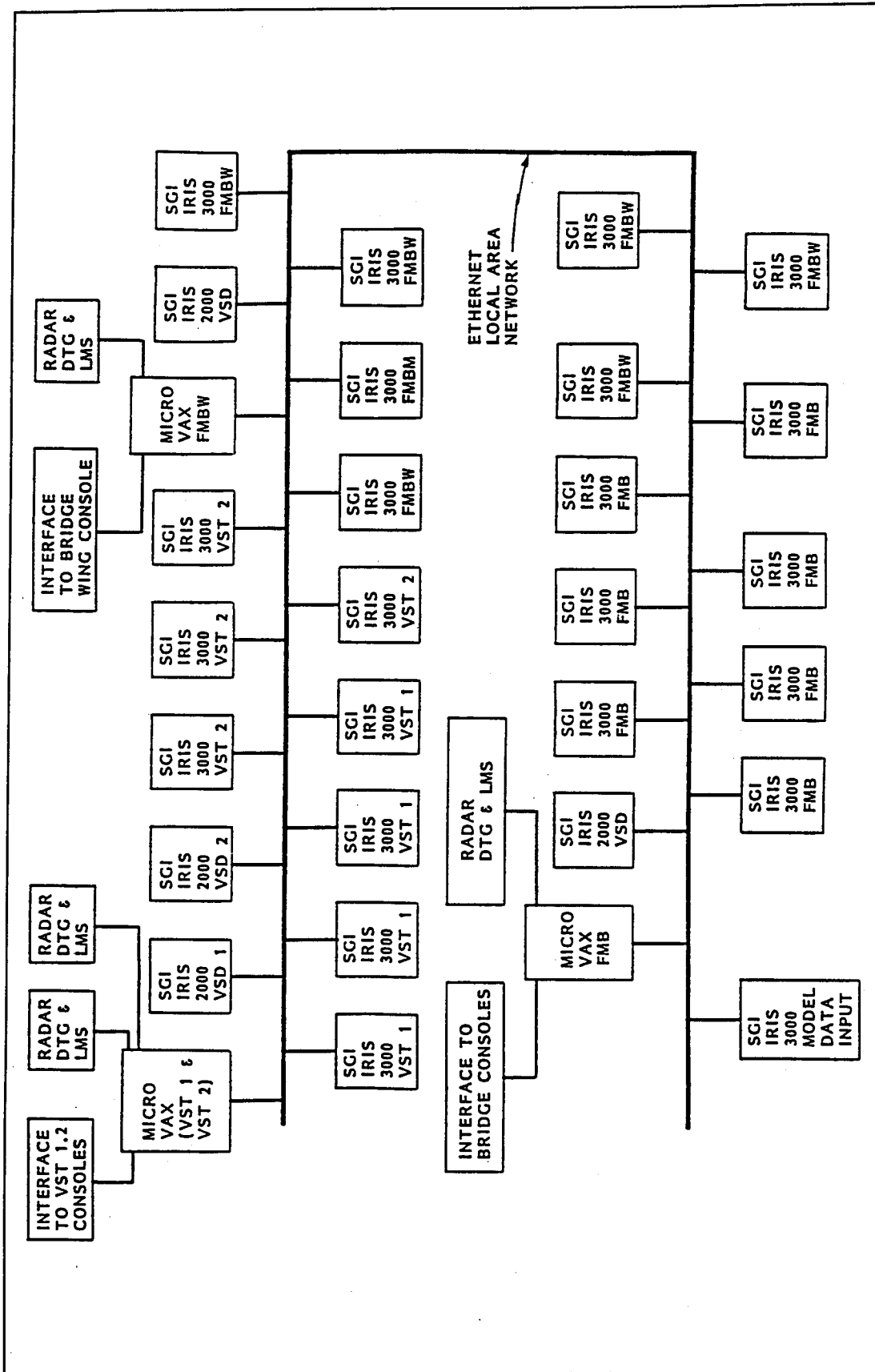

Figure A6. Shiphandling simulator computer network

# **Appendix B Pilot Questionnaire**

---

**LA2020 Port Study**

**SCENARIO DEBRIEFING FORM**

Pilot # \_\_\_\_\_ Scenario # \_\_\_\_\_ File # \_\_\_\_\_

Wind/Current/Wave: \_\_\_\_\_

1. On the scale below, rate the difficulty of the simulator run just completed compared to what you would expect given the set of test conditions. For example, if the difficulty was just as you would expect in reality give a rating of 5, if you thought the run was more difficult than expected give a rating of greater than 5, if less difficult the rating would be less than 5.

0 1 2 3 4 5 6 7 8 9 10

2. Overall difficulty in keeping position of the ship for the entire run was:

0 1 2 3 4 5 6 7 8 9 10

3. Overall level of difficulty in keeping position of the ship in the entrance channel was:

0 1 2 3 4 5 6 7 8 9 10

4. Level of difficulty in keeping position of the ship as you entered the breakwater was:

0 1 2 3 4 5 6 7 8 9 10

5. Level of difficulty in keeping position of the ship as you entered the breakwater was:

0 1 2 3 4 5 6 7 8 9 10

6. Level of difficulty in keeping position of the ship at the entrance of the turning circle was:

0 1 2 3 4 5 6 7 8 9 10

7. Level of difficulty in keeping position of the ship in the turning circle was:

0 1 2 3 4 5 6 7 8 9 10

8. Level of difficulty in keeping position of the ship from the turning circle to the berth was:

0 1 2 3 4 5 6 7 8 9 10

9. Would you do this maneuver any differently if you had the chance to do it again? Please explain: \_\_\_\_\_

---

---

---

---

10. Was there any aspect of the simulation that had an adverse or beneficial effect on this maneuver? \_\_\_\_\_

---

---

---

---

11. What, if any, changes would you like to see made to the aids to navigation or port infrastructure: \_\_\_\_\_  
\_\_\_\_\_  
\_\_\_\_\_  
\_\_\_\_\_  
\_\_\_\_\_

12. Additional comments: \_\_\_\_\_  
\_\_\_\_\_  
\_\_\_\_\_  
\_\_\_\_\_  
\_\_\_\_\_  
\_\_\_\_\_  
\_\_\_\_\_  
\_\_\_\_\_

# REPORT DOCUMENTATION PAGE

Form Approved  
OMB No. 0704-0188

Public reporting burden for this collection of information is estimated to average 1 hour per response, including the time for reviewing instructions, searching existing data sources, gathering and maintaining the data needed, and completing and reviewing the collection of information. Send comments regarding this burden estimate or any other aspect of this collection of information, including suggestions for reducing this burden, to Washington Headquarters Services, Directorate for Information Operations and Reports, 1215 Jefferson Davis Highway, Suite 1204, Arlington, VA 22202-4302, and to the Office of Management and Budget, Paperwork Reduction Project (0704-0188), Washington, DC 20503.

|   |  |   |   |                            |
|---|--|---|---|----------------------------|
| 1. AGENCY USE ONLY (Leave blank)  |  | 2. REPORT DATE<br>November 1994                             | 3. REPORT TYPE AND DATES COVERED<br>Final report                            |                            |
| 4. TITLE AND SUBTITLE<br>Ship Navigation Simulation Study, Los Angeles Harbor,<br>Los Angeles, California   |  |   | 5. FUNDING NUMBERS  |                            |
| 6. AUTHOR(S)<br>J. Christopher Hewlett  |  |   |   |                            |
| 7. PERFORMING ORGANIZATION NAME(S) AND ADDRESS(ES)<br>U.S. Army Engineer Waterways Experiment Station<br>3909 Halls Ferry Road<br>Vicksburg, MS 39180-6199  |  |   | 8. PERFORMING ORGANIZATION<br>REPORT NUMBER<br>Technical Report<br>HL-94-16 |                            |
| 9. SPONSORING/MONITORING AGENCY NAME(S) AND ADDRESS(ES)<br>U.S. Army Engineer District, Los Angeles<br>P.O. Box 2711<br>Los Angeles, CA 90053-2325  |  |   | 10. SPONSORING/MONITORING<br>AGENCY REPORT NUMBER                           |                            |
| 11. SUPPLEMENTARY NOTES<br>Available from the National Technical Information Service, 5285 Port Royal Road, Springfield, VA 22161.  |  |   |   |                            |
| 12a. DISTRIBUTION / AVAILABILITY STATEMENT<br>Approved for public release; distribution is unlimited.   |  |   | 12b. DISTRIBUTION CODE  |                            |
| 13. ABSTRACT (Maximum 200 words)<br><br>A real-time ship simulation study of the proposed design for new navigation channels serving future port development in Los Angeles, CA, was conducted. The purpose of the study was to determine both the required channel size for the Federal interest and the safety of the actual channels being constructed by the Port of Los Angeles. The simulations were conducted at Marine Safety International's facility in Newport, RI. Channel currents for the simulation tests were developed at the Coastal Engineering Research Center at the U.S. Army Engineer Waterways Experiment Station (WES). Simulation data analysis and reporting were conducted by the Hydraulics Laboratory at WES. |  |   |   |                            |
| 14. SUBJECT TERMS<br>Channel design<br>Deepwater channel navigation<br>Los Angeles Harbor   |  |   | 15. NUMBER OF PAGES<br>361  |                            |
|   |  |   | 16. PRICE CODE  |                            |
| 17. SECURITY CLASSIFICATION<br>OF REPORT<br>UNCLASSIFIED  |  | 18. SECURITY CLASSIFICATION<br>OF THIS PAGE<br>UNCLASSIFIED | 19. SECURITY CLASSIFICATION<br>OF ABSTRACT                                  | 20. LIMITATION OF ABSTRACT |