

DTIC
SELECTED
JAN 05 1994
F

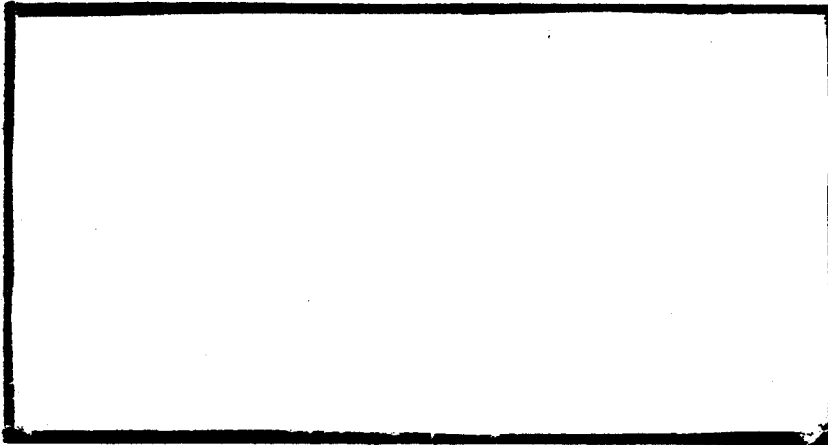

This document has been approved
for public release and sale; its
distribution is unlimited.

DEPARTMENT OF THE AIR FORCE
AIR UNIVERSITY
AIR FORCE INSTITUTE OF TECHNOLOGY

Wright-Patterson Air Force Base, Ohio

19950103 068

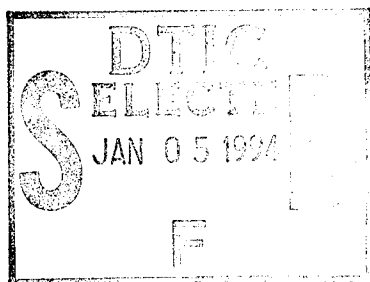

AN IMPROVED HEURISTIC FOR INTERCONTINENTAL
BALLISTIC MISSILE CREW SCHEDULING

THESIS

Michael D. Shirley Jr.
Captain, USAF

AFIT/GOA/ENS/94D-01

Accession For	
NTIS CRA&I	<input checked="" type="checkbox"/>
DTIC TAB	<input type="checkbox"/>
Unannounced	<input type="checkbox"/>
Justification	
By	
Distribution /	
Availability Codes	
Dist	Avail and/or Specs
A-1	

DTIC QUALITY INSPECTED 3

The views expressed in this thesis are those of the author and do not reflect the official policy or position of the Department of Defense or the U. S. Government.

THESIS APPROVAL

STUDENT: Michael D. Shirley Jr., Capt, USAF

CLASS: GOA-94D

THESIS TITLE: AN IMPROVED HEURISTIC FOR INTERCONTINENTAL
BALLISTIC MISSILE CREW SCHEDULING

DEFENSE DATE: 22 November 1994

COMMITTEE:

Name/Title/Department

Signature

Advisor:

James T. Moore, Lt Col, USAF, Ph.D.
Associate Professor of Operations Research
Department of Operational Sciences
Graduate School of Engineering

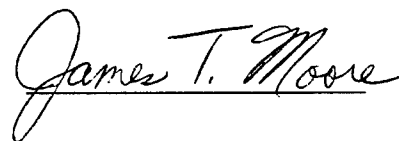
A handwritten signature in cursive script that reads "James T. Moore". The signature is written in black ink and is positioned to the right of the advisor's name and title.

Reader:

James W. Chrissis, Ph.D., P.E.
Associate Professor of Operations Research
Department of Operational Sciences
Graduate School of Engineering

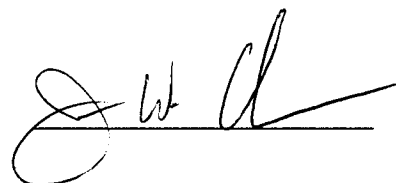
A handwritten signature in cursive script that reads "J W Chrissis". The signature is written in black ink and is positioned to the right of the reader's name and title.

AFIT/GOA/ENS/94D-01

AN IMPROVED HEURISTIC FOR INTERCONTINENTAL BALLISTIC MISSILE
CREW SCHEDULING

THESIS

Presented to the Faculty of the Graduate School of Engineering

of the Air Force Institute of Technology

Air University

In Partial Fulfillment of the

Requirements for the Degree of

Master of Science in Operations Research

Michael D. Shirley Jr., M.A.S.

Captain, USAF

DECEMBER, 1994

Approved for public release; distribution unlimited

ACKNOWLEDGMENTS

While researching the problem, gathering data, and writing this document, I had a great deal of assistance from others. I would like to express my sincere appreciation to my faculty advisor, Lt Col James Moore, for his insight and guidance. I would also like to thank Dr. James Chrissis for his help and constructive comments. I would like to thank my sponsor, Air Force Space Command, particularly Mr. Pat Phelps. Without Mr. Phelps's assistance, this problem could not have been solved. Additionally I would like to thank the missile crew members who gave of their time and resources at Malmstrom AFB. In particular, special thanks goes to Maj Don Wardle, Capt Kent Dalton, Capt Jeff Flewelling, Capt David Boudreau, Capt Mosely Soule, Capt Terry Plumb, and Capt Ted Kracht for their patience and understanding. I also would like to thank Capt Rey Canton and Lt C. Shane Clark from F.E. Warren AFB for their help.

Most importantly I would like to thank my wife Krista, and son Brandon for their love and support. Finally I would like to thank the Lord for his answers to my numerous prayers.

Michael D. Shirley Jr.

Table of Contents

	Page
Acknowledgments	ii
List of Figures	vii
List of Tables	ix
Abstract	x
I. Introduction	1-1
Background	1-1
The Missile Wing	1-1
Operations Group	1-2
Missile Squadron	1-3
Missile Flight	1-3
Missile Combat Crew (MCC)	1-5
Operations Support Squadron (OSS)	1-6
Operations Scheduling Division (DOS)	1-7
Current Schedule Building Procedure	1-7
Problem Statement	1-8
Research Objectives	1-8
Research Assumptions	1-9
Overview of the Subsequent Chapters	1-10
II. Literature Review	2-1
Scheduling Theory	2-1
Constraints	2-1
Performance Measures	2-2

	Page
Previous Attempts to Solve the Problem	2-4
Simulation Model	2-4
Genetic Algorithm	2-5
Current Heuristic: Missile Crew Scheduling Information System (MCSIS)	2-5
Automatic Scheduler.....	2-6
Mixed Integer Programming Approach	2-6
A Small Problem	2-7
Computational Complexity and Heuristics	2-13
III. Problem Formulation	3-1
Overview	3-1
Multiple Objectives	3-1
Decision Variables	3-4
Constraints/Rules	3-5
Preprocessing.....	3-7
Preprocessing Example.....	3-9
Summary	3-11
IV. The Improved Heuristic.....	4-1
Overview	4-1
Scheduling Objectives	4-1
The New Scheduling Heuristic	4-2
The New Algorithm	4-4
Inputs.....	4-4
Details of the New Algorithm	4-7
Requirements to be Met	4-8

	Page
Scheduling Recurring Training.....	4-8
Scheduling Alerts and Backups.....	4-12
Ranking Launch Control Facilities.....	4-13
Scheduling Integral Alerts/Backups	4-16
Scheduling Non-integral Alerts and Backups	4-18
Output.....	4-20
Summary	4-21
V. Verification and Validation	5-1
Overview	5-1
The Test Data Set	5-1
Testing.....	5-3
Phase I	5-3
Phase II.....	5-5
Phase III.....	5-6
Phase IV	5-8
Phase V.....	5-9
Phase VI	5-11
Testing Summary.....	5-13
Implementation.....	5-14
Summary	5-15
VI. Conclusions and Recommendations	6-1
Conclusions	6-1
Primary Objective	6-1
Secondary Objectives.....	6-2
Recommendations.....	6-2

	Page
Appendix A. Crew Survey Questionnaire.....	A-1
Appendix B. Statistical Tests Concerning Survey Results.....	B-1
Appendix C. User's Guide.....	C-1
Appendix D. Alert Information Spreadsheet.....	D-1
Appendix E. Statistics Output File.....	E-1
Appendix F. Crew Schedule File.....	F-1
Bibliography.....	BIB-1
Vita.....	VIT-1

List of Figures

Figure	Page
1.1. 341st Operations Group Structure	1-2
1.2. Typical Squadron Command Structure.....	1-5
1.3. 341st OSS/DOS Scheduling Procedure.....	1-8
2.1. Performance Measures, Survey Results.....	2-4
2.2. Feasible Schedule - Two List Method	2-8
2.3. First Math Program Schedule.....	2-10
2.4. Alert Distribution - First Math Program.....	2-10
2.5. Second Math Program Schedule	2-11
2.6. Alert Distribution With Difference Equations.....	2-11
3.1. Events Contained in Preprocessing Example	3-9
3.2. Example Preprocessing Crew Member Schedule.....	3-10
4.1. The Scheduling Process Overview	4-3
4.2. Algorithm Overview	4-9
4.3. Detailed Algorithm Overview	4-10
4.4. Flow of Class Scheduling Procedure.....	4-11
4.5. Flow of LCF Ranking Procedure	4-14
4.6. Flow of Integral Alert/Backup Procedure.....	4-17
4.7. Flow of Non-integral Alert/Backup Procedure.....	4-20
1. Alert Information.....	C-1
2. Days Alerts Are Required.....	C-7
3. Alert Distribution Matrix	C-9

Figure	Page
4. Schedule Rule Blocks	C-11
5. SCP Information.....	C-12
6. Crew Member Individual Information	C-13
7. Example Crew Member Attributes.....	C-15
8. First Days of Crew Schedule and T1, T3/4 Days.....	C-17
9. Last Few Days of Crew Member Schedule.....	C-20
10. Schedule Statistics	C-22
11. Crew Member Information	C-23
12. Crew Member Historical Data	C-23

List of Tables

Table	Page
3.1. Ranked Survey Results	3-3
3.2. Operations Flight Commanders Survey Results	3-4
3.3. Categories of Events for Scheduling Alerts and Backups.....	3-8
4.1. Objective Attributes.....	4-2
4.2. Inputs Made by Squadron Schedulers	4-4
4.3. Alert Distribution Matrix	4-5
4.4. LCF Information Entered by Wing Schedulers	4-7
4.5. How Launch Control Facilities are Ranked	4-15
5.1. Test Data Set Information.....	5-2
5.2. Inputs for Phase I	5-4
5.3. Output Results for Phase I	5-5
5.4. Inputs for Phase II	5-6
5.5. Output Results for Phase II.....	5-6
5.6. Inputs for Phase III.....	5-7
5.7. Output Results for Phase III	5-8
5.8. Inputs for Phase IV.....	5-8
5.9. Output Results for Phase IV	5-9
5.10. Inputs for Phase V	5-10
5.11. Output Results for Phase V.....	5-11
5.12. Inputs for Phase VI.....	5-12
5.13. Output Results for Phase VI	5-12
5.14. Summary of Validation Experiments	5-13
5.15. Summary of Comparison of Old and New Algorithm	5-14

ABSTRACT

Creating monthly schedules for missile crews is a complex and time consuming problem. Thousands of events must be scheduled for several hundred missile officers. The rules and regulations governing the problem are numerous, and there are currently no established quality measures for missile crew schedules. The scheduling software currently available only schedules a fraction of the required events.

The objectives of this research were to create a rule based heuristic which could quickly produce feasible or near-feasible schedules, to make the scheduling process paperless, and to develop possible measures of effectiveness for missile crew schedules. The research was successful in each of these areas. Schedules which comply with all rules and regulations were generated by the heuristic. From 95 to 100 percent of the required events were scheduled. The heuristic required from five to 40 seconds to create a schedule using hardware available at a missile wing. Spreadsheets were used to preprocess the data before it was input to the heuristic. This approach made the process paperless. Eight potential objectives which were previously not used as quality measures for missile crew schedules were obtained. These objectives along with those contained in regulations are supported by the rule based heuristic.

AN IMPROVED HEURISTIC FOR INTERCONTINENTAL BALLISTIC MISSILE CREW SCHEDULING

I. INTRODUCTION

Background

Intercontinental ballistic missiles (ICBMs) are ready for launch 24 hours a day, 365 days a year. The daily maintenance and operations of these missiles are the responsibility of Air Force Space Command (AFSPACECOM). Space Command requires that each missile wing maintain and monitor their missiles on a daily basis. Missile Combat Crews (MCC), hereafter referred to as missile crews, are scheduled each month for duties and training in support of the wing's mission. At each missile wing, approximately 1,500 to 2,000 events involving missile crews are scheduled each month. Scheduling and deconflicting these events without the help of a computer is a time-consuming process which requires a large number of hours each month. Automating this process can decrease the number of hours each missile wing invests in the scheduling process. Before specifically discussing the scheduling of missile crews, background on the organization of missile wings and their personnel is presented.

The Missile Wing

There are four operational missile wings and each missile wing is responsible for 150 or 200 missiles. The function of a missile wing is to ensure all personnel, including maintenance, security police, support, and missile crews are properly trained, equipped, and scheduled to watch over, maintain and, if called upon, launch the wing's missiles. A missile wing is further divided into groups which are responsible for a specific area of the wing's overall mission. The Operations Group (OG), the primary focus of this

research, is responsible for providing trained missile crews to monitor the missiles, to coordinate security and maintenance actions associated with the missiles, and to launch the missiles if directed by the President of the United States.

Operations Group

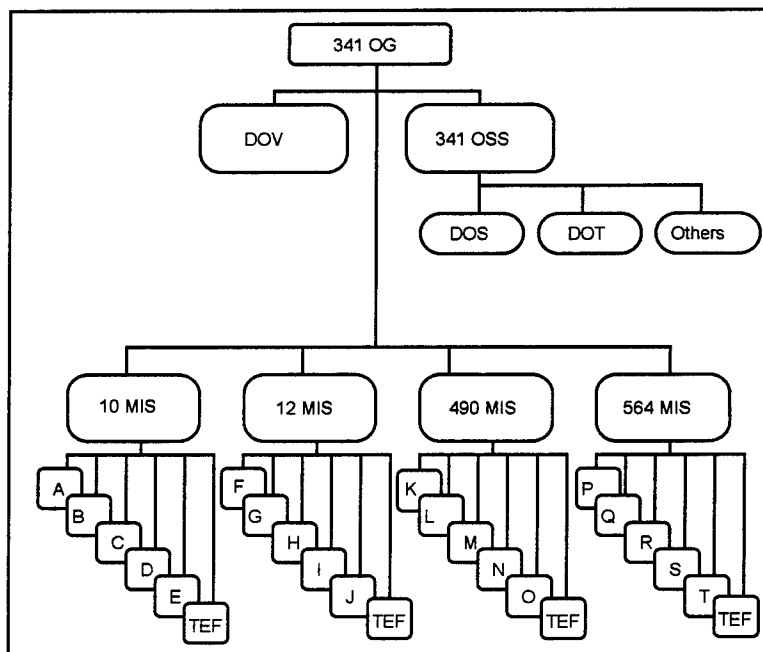

Figure 1.1 341st Operations Group Structure

Each missile operations group in AFSPACECOM is similar in structure to the 341st OG shown in Figure 1.1. The only difference between missile operations groups within AFSPACECOM is the number of missile squadrons within each group; some have four and others have five missile squadrons. The Operations Support Squadron (OSS) provides support to the missile squadrons. This support includes, but is not

limited to, training and providing each missile crew member with a monthly schedule of their activities and duties. Missile crews are discussed later in this chapter.

Missile Squadron

The primary function of a missile squadron is the operation of five Launch Control Facilities (LCF) and 50 Launch Facilities (LF). The LCF houses the personnel who monitor, maintain, and provide security for the LFs and the LCF. The LFs contain the missiles and their support equipment. Each squadron has a Squadron Commander, an Operations Officer, two Operations Flight Commanders (OFC), 50 to 65 missile crew members, administrative personnel, and facility managers. An Operations Flight Commander is typically responsible for two or three of the squadron's five missile flights. Missile crews assigned to a squadron are scheduled for alert duties within their own squadron whenever possible; however, they can be scheduled for alert duties in other squadrons as the need arises (An alert is a 24-hour work shift at an LCF). A backup is a crew member that is scheduled to be ready to go on alert on a given day should something unexpectedly prevent one of the crew members currently scheduled to go on alert from going on alert. Currently a backup commander and a backup deputy are scheduled each day for each weapon system.

Missile Flight. A missile flight is the command structure centered around a single launch control facility and its associated ten launch facilities. Each missile squadron has six flights of personnel; five of these are missile flights. Each flight has approximately ten missile crew members assigned to it and is lead by a crew member designated as the Flight Lead (FL). When missile crews are scheduled for alert duties, they are scheduled for alert at their primary flight, whenever possible.

Each squadron has an LCF whose crew is in charge of operations among the squadron's five LCFs. This LCF is designated the Squadron Command Post (SCP).

Missile crews who are scheduled for alert duties at an SCP must receive additional training on the responsibilities of the SCP and only these SCP-qualified crews are allowed to "pull alert" at the SCPs (To "pull alert" means attend a predeparture briefing, drive to a LCF, work at the LCF for 24 hours, drive back to base, and deliver all required materials to base agencies). SCP-qualified crews can pull alert at non-SCP LCFs.

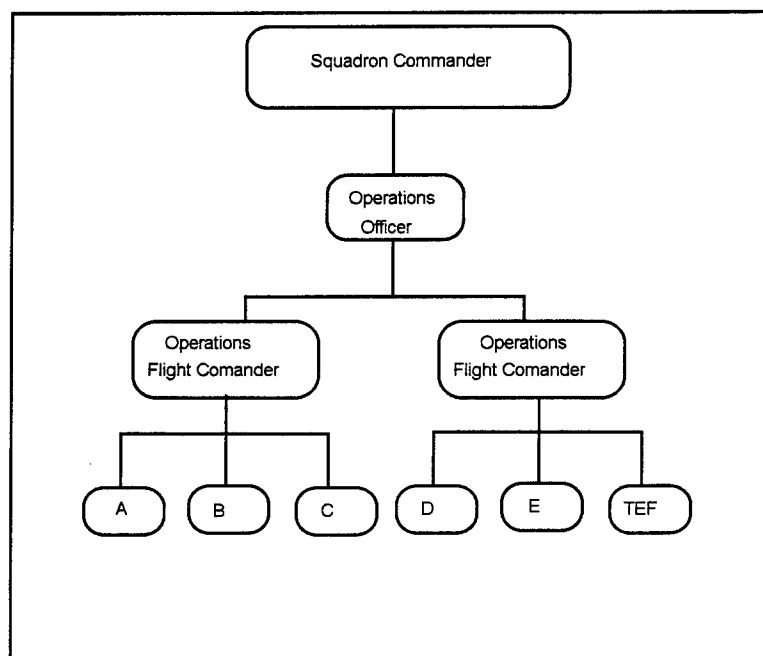

Figure 1.2 Typical Squadron Command Structure

The sixth flight within a squadron is the Training and Evaluation Flight (TEF). This flight has only recently been incorporated into the structure of missile squadrons. The missile crew members assigned to the TEF can pull alert in any LCF because they are SCP-qualified. In addition to pulling alerts, TEF crew members train and evaluate

other squadron members in the Missile Procedure Trainer (MPT) and at the LCFs. The MPT simulates an LCF and is where missile crews are trained in the operation of equipment and the launch of their missiles. Two types of training are accomplished: Weapon System and Emergency War Order (EWO). Weapon system training stresses the day-to-day operation of the support equipment and contingency and security procedures. Emergency War Order training involves classified processing of the President's orders to launch the wing's missiles.

Missile Combat Crew

Two missile officers make up a MCC. Each missile crew member is a Missile Combat Crew Commander (MCCC) or a Deputy Missile Combat Crew Commander (DMCCC). A missile crew is made up of one MCCC and one DMCCC, with some exceptions. Each wing has the latitude to have dual-qualified crew members. Being dual-qualified means a crew member can pull alert as either a MCCC or a DMCCC. There are wings that have instructor crew members, evaluator crew members, and some TEF crew members who are dual-qualified.

Director of Training (DOT) crew members write the lesson plans for classroom instruction and the scenarios used in the MPT, and train all the TEF crew members. Crews in the Director of Evaluation (DOV) section train and certify TEF crews concerning evaluation procedures and standards. Within DOT and DOV is a crew designated as the senior crew for each weapon system. The commander of the senior crew is responsible for all operations within the section. The deputy is responsible in the commander's absence.

Missile crews are required to pull alerts, accomplish training, and perform duties within their squadron. The amount of time spent in each of these areas depends on the crew member's position within the operations group. Almost all crew members start

out as line deputies when they arrive from Undergraduate Missile Training (UMT). After unit orientation training at the wing, most of their time is spent pulling alert and undergoing additional training. After several months, line deputies can move up to TEF, DOT, or DOV positions. After approximately 18 to 24 months, most deputies upgrade and become missile crew commanders. After several months in the position of missile crew commander, crew members are eligible to compete for DOT, DOV, and TEF positions, or become flight leads. Crew members in DOV, DOT and the TEFs pull fewer alerts than line crew members because more of their time is dedicated to other duties.

A normal missile tour is four years, after which a crew member can become an operations flight commander. Operations flight commanders pull a few alerts a month, but most of their time is spent managing personnel within their flights of responsibility. All crew members who pull alert must accomplish a day of weapon system training and a day of EWO classroom training each month. Whenever possible, crew members are scheduled as a crew for training and alert duty. A goal which is stressed at all levels is to schedule each missile crew member for at least one trainer ride per month (A trainer ride is a session in the MPT with instructors present). The instructors can be from DOT or one of the TEFs.

Operations Support Squadron (OSS)

The Operations Support Squadron at each wing assists the operational squadrons and other sections, providing training and administrative functions. Some of the training the OSS accomplishes are monthly EWO (T1), weapon system (T3), and code handler (T4) training.

Operations Scheduling Division (DOS). One section within the OSS is the scheduling division, made up of four or five full-time wing schedulers. These wing schedulers are former missile crew members who have completed their operational tour. They have no required formal scheduling or computer training; however, many have been schedulers at the squadron/division level. Squadron/division schedulers coordinate requests within their squadron/division and submit their scheduling inputs to the wing schedulers. The wing schedulers coordinate the timing and deconfliction of events and build the monthly wing schedule. On a daily basis, the wing schedulers update the schedule and inform the squadrons/divisions of changes required for a variety of contingencies such as illness, failed evaluation, or weather problems.

Current Schedule Building Procedure

Every missile wing must comply with all regulations as they build and maintain the monthly schedule; however, each wing is given latitude in executing that mission. Figure 1.3 contains an overview of the procedure used to build a monthly schedule at the 341st OSS/DOS, Malmstrom Air Force Base (AFB), Montana.

Squadron and division schedulers manually complete forms which contain the monthly scheduling inputs. As a minimum, these inputs include crew pairings, leave requests, temporary duty (TDY), academic days, special training requirements, squadron functions, rank changes, and other special requests. Completing these forms is time consuming and there is the potential for mistakes due to various interpretations of handwritten characters. Once the wing schedulers have all the inputs from the squadrons and divisions, they refer to more detailed procedures to actually build the schedule.

When	Who	What
No later than the third duty day of the month prior to the effective month	Squadron and Division Schedulers	Provide scheduling requests/inputs to DOS
First 3 weeks of the month prior to the effective month	Wing Schedulers	Build the monthly schedule
2-3 days prior to the monthly scheduling meeting	Wing Schedulers	Provide a draft copy of the monthly schedule to Squadrons and Divisions
No later than the 21st of the month prior to the effective month	Squadron, Division, Wing Schedulers	Attend monthly scheduling meeting to solve problems concerning the monthly schedule and to improve the scheduling process
No Later than 5 calendar days prior to the beginning of the effective month	Wing Schedulers	Publish and distribute the monthly schedule

Figure 1.3 341st OSS/DOS Scheduling Procedure

Problem Statement

The problem of scheduling missile crews for alert duty and required training is twofold. The first problem is to ensure that all required training is scheduled so that crew members have the training required to pull alerts the following month. At the same time, crews must be scheduled to pull alerts at all LCFs requiring manning for the current month, while adhering to current AFSPACECOM regulations, and honoring as many squadron requests as possible. The second problem is to determine the “best” schedule from a set of possible schedules.

Research Objectives

The primary objective of this research is to develop an automated scheduling system which can quickly produce feasible, or near-feasible, monthly schedules for a missile wing. The system should interface with the current hardware and software of a typical missile wing. The schedules must comply with all governing regulations and

include alerts, monthly weapon system, code handler, and EWO training, and all squadron inputs. If feasible schedules cannot be constructed, with all squadron requests satisfied, some requests may have to be relaxed. An example of an input that may be relaxed involves education days. Education days (e-days) are evenings set aside for a crew member to attend academic classes. Attempts are made to schedule all missile crew members for all requested e-days; however, if all mission essential items, such as alerts, cannot be scheduled because of e-days, the number of e-days scheduled will be decreased. This is consistent with current scheduling procedures and policies.

Another objective is to make the scheduling process paperless. To support this objective, the automatic scheduling system should read the inputs from spreadsheets and then build a schedule based on these inputs. Once a schedule is generated, statistics for the schedule should be displayed so schedulers can compare the current schedule with previously generated schedules. Schedulers should then have the capability to chose a schedule and distribute it.

An additional objective is to develop measures of effectiveness for missile crew schedules. Currently, there are no predefined measures of effectiveness for missile crew schedules. A survey of missile personnel at Malmstrom AFB is used as part of this effort. These measures of effectiveness are used to design the algorithm which builds the schedules. After a schedule is chosen from among the schedules produced, it can be modified by wing schedulers and then prepared for distribution. This distribution may be by printed copy or electronic means

Research Assumptions

To conduct this research one assumption was made: dual-qualified crew members will be designated as either commanders or deputies and scheduled for only commander or deputy alerts.

Overview of the Subsequent Chapters

The remaining chapters provide a detailed presentation of the research effort. Chapter II contains a description of the literature relating to the solution of the problem at hand. It also contains brief descriptions of previous attempts to solve the problem. In Chapter III, the objectives of the missile crew scheduling problem are discussed along with rules which must be complied with to generate a feasible schedule. The improved heuristic scheduling system is described in depth in Chapter IV. Testing of the new system is accomplished in Chapter V. Finally, conclusions and recommendations are presented in Chapter VI.

II. Literature Review

This chapter summarizes the theory required to understand the Resource-Constrained Scheduling (RCS) problem and the survey results involving schedule performance measures. A review of previous attempts to solve the missile crew scheduling problem follows. The chapter concludes with an example of a mixed integer formulation and a discussion of complexity theory.

Scheduling Theory

Scheduling is the allocation of resources over time to perform a collection of tasks. (Baker, 1974:2). This allocation of resources usually has to comply with a set of rules or *constraints*. Generally, schedules are judged with respect to some criterion, a measure of effectiveness, so a comparison can be made between schedules.

Constraints. The sequence in which activities are processed often depends on three types of constraints: technological, precedence, and resource (French, 1982:48, 197). Technological constraints restrict the order in which the operations that comprise a particular activity must be processed (French, 1982:5). For example, if the activity is baking a cake, the operation of mixing the ingredients to make a batter must come before the operation of baking the batter in the oven. However, if the level of detail of a scheduling problem assumes that the activities consist of only a single operation, technological constraints do not apply. In the case of the missile crew scheduling problem, the two categories of activities which are to be scheduled are *classroom training* and *alerts*. Since there are no operations within a particular activity in the missile crew scheduling problem, technological constraints do not apply to this problem.

Precedence constraints require that certain activities (rather than operations within an activity) be accomplished before other activities can begin (French, 1982:48). For

example, completion of a drivers' education class may be required before a driver's license examination is scheduled. The order of activities in the missile crew scheduling problem does not matter. Thus, the missile crew scheduling problem does not contain precedence constraints.

Resource constraints limit the number of possible schedules based on the limited levels of resources available for completion of activities (French, 1982:197). For example, if each crew member is required to attend one T1 class each month, and the classes are only offered eight times a month, each crew member must attend T1 class on one of those eight days. The remaining elements of a crew member's schedule must be scheduled around this resource limitation. Resource constraints are the driving force in the missile crew scheduling problem. Thus, the missile crew scheduling problem is a resource constrained scheduling problem.

Performance Measures. Given that a feasible schedule is obtainable, measures of performance are used to compare the "effectiveness" of one feasible schedule relative to another feasible schedule. One possible performance measure for a feasible missile crew schedule is the number of e-days allowed in the schedule. The objectives of a scheduling problem may incorporate multiple goals, ranked in order of importance (French, 1982:25). In many scheduling problems, scheduling objectives are numerous, complex, and often conflicting; therefore, it is often difficult to determine a specific objective as being the most beneficial for a particular problem (French, 1982:9).

Performance measures can also be used to compare one near-feasible schedule to another near-feasible schedule. For this study, a near-feasible schedule is a schedule that does not violate any scheduling rules and schedules at least 85% of the required events. One requirement for a monthly missile crew schedule to be feasible is that one commander and one deputy be scheduled for alert duty each day at each LCF which is operational. If this condition is satisfied by a schedule, then, according to this measure, the schedule is

feasible. If this condition is not satisfied, the measure of how many alerts are unscheduled can be used as a measure of goodness. A schedule which has two alerts requiring crews is deemed better by this measure than a schedule which has five alerts requiring crews.

In order to define realistic performance measures for the missile crew scheduling problem, interviews and group discussions involving missile crew members and missile staff officers at Malmstrom AFB were conducted. The results of these meetings were used to develop a survey which was distributed and completed by over 200 wing personnel (A copy of this survey is contained in Appendix A) (Dalton, 1994:13). In the survey, the participants were asked to distribute 100 points among eight objectives: 1) integral alerts; 2) squadron integrity; 3) workload equalization; 4) X-days; 5) e-days; 6) leave; 7) each crew getting at least one MPT session per month; and 8) SCP crews getting at least one SCP alert per month.

An integral alert is an alert in which the commander and the deputy scheduled for the alert are crew partners. Squadron integrity is measured by the percentage of alerts which are scheduled for members of a particular squadron which are within the given squadron. For example, if squadron 1 consists of the LCFs A, B, C, D, and E, and 10% of the alerts squadron 1's crew members have are not at A, B, C, D, or E, then the squadron integrity rate is 90%. Workload equalization is scheduling crew members with the same general duties, for example flight leaders, with the same number of alerts. X-days are requested days off. If crew members would like a certain day off, they can request an X-day. Unlike leave, an X-day is not guaranteed; however, schedulers try to build a crew member's schedule around these days.

The results of this survey are displayed in Figure 2.1 (Dalton, 1994:19). If someone is indifferent about these objectives, an equal weight of 12.5 for each objective would be observed. A full statistical evaluation is contained in Appendix B. Only two measures were deemed statistically significant, those involving leave and education days.

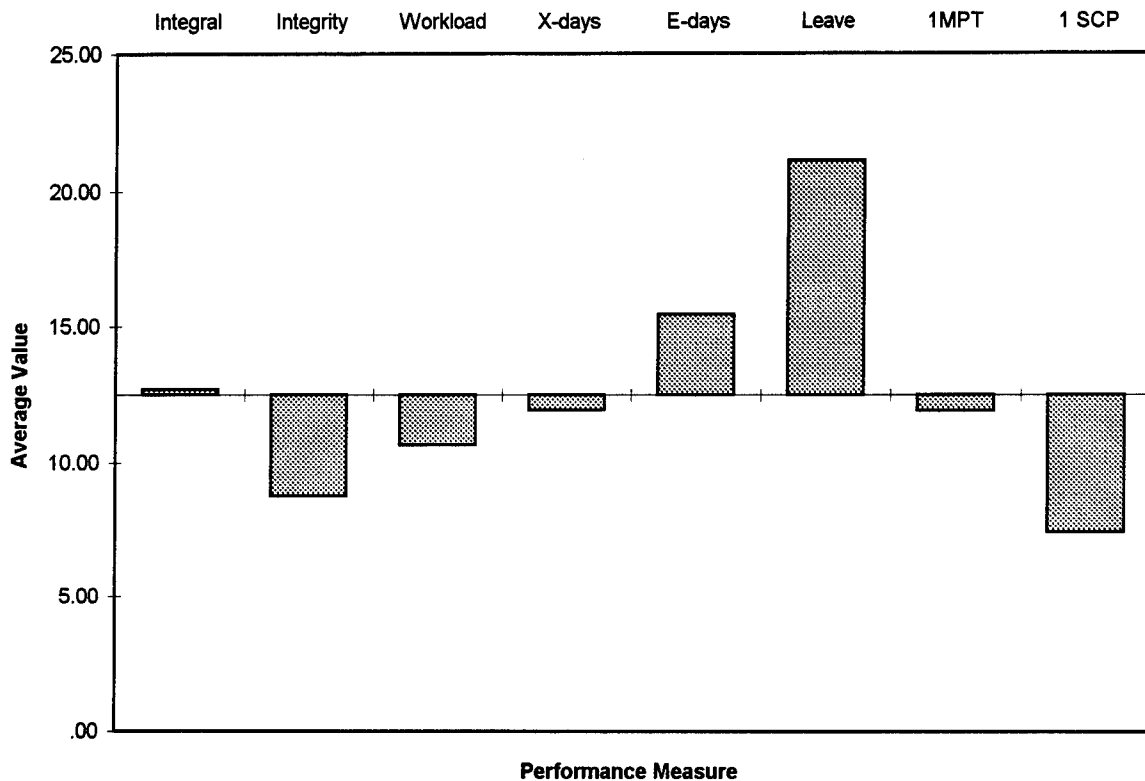

Figure 2.1 Performance Measures, Survey Results

Previous Attempts to Solve the Problem

Previously, three methods had been used in attempts to solve the missile crew scheduling problem: simulation, genetic algorithms, and a heuristic. In the first two attempts, the problem was simplified significantly. These simplifications kept the methodologies of the work from being used at an actual missile wing.

Simulation Model. In their 1984 study, Berg and Nuss used a simulation approach to model the scheduling process, modeling each crew as an entity that moves through the process. Two major assumptions were made in the study. The first and most important assumption is that crews, rather than individuals, are scheduled. This simplifies the problem; however, it departs significantly from reality because often the schedules of

commanders and deputies on the same crew differ (Berg and Nuss, 1984:Chap I, 24). These differences between crew partners' schedules are due to education days, leave, physical and dental appointments, TDY, and many other factors. The other major assumption is that the dates for weapon system training, EWO training, MPTs, and leave are determined by the model (Berg and Nuss, 1984 Chap I, 5). The dates and times these items are available for scheduling are usually fixed before a schedule is built. Support organizations have to schedule instructors and classrooms, so the dates and times of monthly classroom training are currently inputs rather than variables.

Genetic Algorithm. A more recent attempt at solving the missile crew scheduling problem employed a genetic algorithm, an artificial intelligence search method based on the idea of natural selection and evolution. A genetic algorithm was used to solve a smaller and simpler version of the missile crew scheduling problem. This version of the problem involved one squadron and a subset of possible activities. Using the current computer hardware typical of a wing scheduling office, the genetic algorithm took 14 hours to solve the simplified problem. The objective function of this approach checks a series of conditions and adds a predefined penalty based on the number of occurrences of a condition (Forbes, 1993:30). An example of a condition which incurs a penalty is leaving an alert unscheduled. The total score a schedule is assessed indicates how far the schedule is from optimal. An objective function value of zero indicates no penalties were assessed, and the schedule is optimal by this measure (Forbes, 1993:31). The amount of time required to solve a real world problem involving all possible inputs and three or four squadrons is unknown, but probably exceeds 14 hours.

Current Heuristic: Missile Crew Scheduling Information System (MCSIS). The MCSIS program automates the missile crew scheduling process, maintaining crew schedules on a day-to-day basis and providing reports. MCSIS was

designed to ease the preparation of crew schedules by using a rule-based scheduling algorithm to generate monthly missile crew schedules.

Automatic Scheduler. The automatic scheduling procedure within MCSIS gathers information from various databases and combines them with scheduling rules to produce crew schedules for a particular month. The procedure does not schedule any monthly training classes or backups. The automatic scheduler within MCSIS operates as follows:

This program makes four passes to compute a schedule. The first pass schedules full crews by flight. On the second pass, it schedules full crews by organization (i.e. crews from flight A pulling alerts on LCF B, only when LCF B belongs to the same organization). On the third pass, it schedules mixed crews by flight, and on the fourth pass, it schedules mixed crews by organization. It never schedules crews from one organization to an LCF belonging to another organization. When scheduling, it finds the crew with the lowest alert count and schedules it. It then updates the alert count. It again looks at the crew with the lowest alert count and schedules it. If a crew reaches its maximum alert count it is no longer looked at by the program. (SAC Manual 171-104, 1992:Section 5, 3).

Not allowing crews from one squadron to pull alert in another squadron, even though they are fully qualified, is the major flaw in this algorithm. This over constrains the problem and makes generating feasible schedules difficult.

Mixed Integer Programming Approach

Many crew scheduling problems seem trivial at first glance: there is a list of crews available and there is a list of shifts to be worked. One approach to solving the crew scheduling problem is to rotate through the list of crews, assigning the first crew on the list the first shift available and to continue until the list of shifts is exhausted. The crew scheduling problem can be complicated by many conditions. Some of the conditions that complicate a crew scheduling problem are: crew members with varying skill levels, shifts

requiring varying skill levels, and policy or law requiring different shifts to be paid at different hourly rates depending on the time of day. Other complicating conditions include: workers who can only work days, nights, or afternoons and union rules and regulations which require vacations, sick days and maternity leave. It does not take many considerations to turn a simple scheduling problem into a complex scheduling problem.

Mixed integer programming has been used to solve many scheduling problems. By making many simplifying assumptions and ignoring numerous constraints, a small problem similar to the missile crew scheduling problem can be formulated as a mixed integer program. This will illustrate why using a mixed integer programming formulation on a missile crew scheduling problem is not reasonable due to the number of variables and constraints required.

A Small Problem. Consider a small missile crew scheduling problem with the following characteristics:

1. 7 days (1, 2, 3, 4, 5, 6, 7).
2. 7 missile crews (A, B, C, D, E, F, G).
3. 2 Launch Control Facilities (LCFs) (1, 2).
4. Each LCF must be manned 24 hours a day by one crew at a time.
5. Each crew can only go on an alert once in a three day period.

Using this data, it is easy to generate a feasible schedule using the two list method previously mentioned. Taking the first available crew and assigning them to the next available alert results in the following schedule with each crew assigned two alerts.

	DAYS						
LCF	1	2	3	4	5	6	7
1	A	C	E	G	B	D	F
2	B	D	F	A	C	E	G

Figure 2.2 Feasible Schedule - Two List Method

This simple problem increases in difficulty when realistic constraints are added to the problem. Suppose crew A is an instructor crew and, because of their additional duties, they can only be assigned one alert. Crew A also needs to teach a class the morning of day 2, so they cannot pull alert on days 1 and 2. Also, crew B attends classes on day 3, and crew C wants to go on leave days 2, 3, and 7. Crew C does not want to waste a half-day of leave driving back from alert, so they want to be scheduled for duties other than alert on days 1 and 6. With these additional requests, finding a feasible, equitable schedule is not easy. The following mathematical model generates a feasible schedule:

Let $X_{ijk} = \{1 \text{ if crew } i \text{ pulls alert at capsule } j \text{ on day } k,$
 $0 \text{ Otherwise}\}$

where $i = A, B, C, D, E, F, G$
 $j = 1, 2$
 $k = 1, 2, \dots, 7$

For example: if $X_{A14} = 1$ crew A will pull alert in LCF 1 on day 4
if $X_{A14} = 0$ crew A will not pull alert in LCF 1 on day 4

Let Y_i be the total number of alerts crew i is assigned over the seven day period.

The Y_i variable is not required but aids in the evaluation of schedules. When calculations are made concerning the number of variables required to formulate this problem, these variables will not be included.

The objective is to meet all the requests for days off while ensuring all LCFs are manned 24 hours a day. The objective function and the constraints of a mathematical program which generates a feasible solution are displayed below.

Minimize the number of requests which cannot be granted:

Minimize

$$X_{A11} + X_{A21} + X_{A12} + X_{A22} + X_{B13} + X_{B23} + X_{C11} + X_{C21} + X_{C12} + X_{C22} + X_{C13} + X_{C23} + X_{C16} + X_{C26} + X_{C17} + X_{C27}$$

Subject to the constraints:

There must be one crew scheduled for each alert.

$$\sum_{i=A}^G X_{ijk} = 1 \quad \forall j, k \quad (2-1)$$

Each crew can only go on alert once every three days.

$$\sum_{j=1}^2 \sum_{k=m}^{m+2} X_{ijk} \leq 1 \quad \forall i, m = 1, 2, 3, 4, 5 \quad (2-2)$$

Y_i is the total number of alerts crew i is assigned.

$$\sum_{j=1}^2 \sum_{k=1}^7 X_{ijk} - Y_i = 0 \quad \forall i \quad (2-3)$$

Each instructor crew can only pull one alert.

$$Y_A \leq 1 \quad (2-4)$$

$$Y_i \geq 0 \quad i = A, \dots, G$$

$$X_{ijk} \in \{0,1\} \quad \forall i, j, k$$

The solution had an objection function value of zero which means all requests were granted. The schedule is:

	DAYS						
LCF	1	2	3	4	5	6	7
1	F	B	E	F	B	D	G
2	G	D	A	G	C	E	F

Figure 2.3 First Math Program Schedule

CREW	Number of Alerts Assigned
A	1
B	2
C	1
D	2
E	2
F	3
G	3

Figure 2.4 Alert Distribution - First Math Program

All requests are satisfied and every alert is covered. However, the schedule is not balanced, as crew C has one alert while crews F and G each have three alerts. The workload can be balanced by adding constraints. These constraints, (2-5), ensure the difference in total alerts pulled per crew for noninstructor crews does not vary by more than one alert:

$$-1 \leq Y_i - Y_k \leq 1 \quad (2-5)$$

$$\forall i, k$$

$$i \neq A$$

$$i < k$$

The objective value of this second program is one, which means one of the requests was not satisfied. In this case, crew C did not get day 2 off. The schedule is:

	DAYS						
LCF	1	2	3	4	5	6	7
1	F	B	E	D	B	G	F
2	D	C	G	F	C	E	A

Figure 2.5 Second Math Program Schedule

CREW	Number of Alerts Assigned
A	1
B	2
C	2
D	2
E	2
F	3
G	2

Figure 2.6 Alert Distribution With Difference Equations

The question as to which of these two schedules is better must be addressed. Crew C would favor the first schedule, while crew G would favor the second. An alternate formulation substitutes simple lower bounds (2-6) for the difference constraints (2-5).

$$Y_i \geq 2 \quad i = B, C, \dots, G \quad (2-6)$$

Replacing constraint (2-5) with constraint (2-6) also yields an objective function value of one. A requested day off for crew C cannot be granted and crew C is required to pull two alerts. These constraints may be employed if the lower bound on the number of alerts each crew should pull is known. This information may possibly come from a regulation. If this formulation provides a feasible schedule and grants the requests for days off, it should please almost everyone. If it does not satisfy all the requests, the variables can be weighted in the objective function. There will still be unsatisfied demands; however, they will now be prioritized. It should be clear that a schedule involving shift work is a series of tradeoffs among schedulees. An individual cannot be given extra time off without creating additional work for someone else.

When applied to a missile wing, the size of the mathematical program generated by the simplest model, considering only constraints generated by (2-1), becomes large very quickly. Remember also, this model is a simplification of the missile crew scheduling problem. Usually, individual crew members rather than crews are scheduled. Also, some LCFs require crew members with additional training and numerous training days are required each month for each crew member. For a seven-day, two-facility, seven-crew model, the model has $98 = (7 \times 2 \times 7)$ variables. Using this model for a realistically sized problem requires:

$$31 \text{ (#days)} \times 15 \text{ (LCFs)} \times 100 \text{ (crews)} = 46,500 \text{ variables.}$$

The number of constraints required to model a problem of this size would be:

Ensure one crew is assigned to each alert	31 (days) x 15 (LCFs)	465
Ensure no crew goes on alert more than once in a three day period		
	100 (crews) x 29 (groups of three days)	+2,900
Total Number of Constraints Required		3,365

Given sufficient time and computer resources, this simplified version of the problem can be formulated and solved using mathematical programming. At an operational wing, schedulers have neither the expertise nor the computer resources to maintain and manipulate a mathematical program of this size. Since they cannot manage the simplified version of the problem, the fully expanded problem is not practical. Wing schedulers need results in a timely fashion with a readable format which can be maintained and executed using their current resources. A mathematical programming problem of this size does not satisfy wing scheduling requirements.

Computational Complexity and Heuristics

Mathematical programming problems are often classified based on their complexity. In complexity theory, there are two broad classes of decision problems: polynomial (P) and nondeterministic polynomial (NP). In order to qualify for the class P, a decision problem must actually be solvable in polynomial-bounded time (Parker and Rardin, 1982:8). The class NP is the set of problems for which solution algorithms with exponential behavior have been found. The class P is contained within NP. NP-complete problems are a subset of NP problems and are the hardest of the NP problems to solve. In resource-constrained problems for large projects, the size of the problem may render optimal methods computationally impracticable (Baker, 1974:279). This is the case with the problem at hand. Baker goes on to say, "In such cases, the problem is most amenable to heuristic problem solving, using fairly simple rules capable of producing reasonably good suboptimal schedules." This is the approach used in this research.

The problem size, complexity, and computer resources available to wing schedulers indicate a heuristic solution technique is the best approach for solving the missile crew scheduling problem. To generate feasible or near-feasible schedules, the heuristic must capture the rules which govern missile crew scheduling. If the heuristic is

capable of generating multiple feasible or near-feasible schedules in a relatively short period of time, performance measures must be generated which make comparing these potential schedules possible. The next chapter describes the objectives of the missile crew scheduling problem and the rules and constraints which drive the problem.

III. Problem Formulation

Overview

The purpose of this chapter is to describe the missile crew scheduling problem in detail. First the objectives used to build schedules are discussed. These objectives are goals which the heuristic must support in order to produce a quality schedule. Next, the decision variables are characterized. Although the heuristic is not a mathematical program, decisions involving what is scheduled on a given day for a given crew member must be made. Then the constraints of the problem are specified. The constraints of the problem can also be viewed as rules. These rules must be followed in order to comply with current AFSPACECOM scheduling policies. Finally, a method of preprocessing the inputs which are generated at the squadron level are described followed by an example of how the preprocessing works.

Multiple Objectives

Like many scheduling problems, the missile crew scheduling problem has several possible objectives. The survey of crew members at Malmstrom AFB provided potential objectives; however, other objectives are derived from regulations. The following objectives were extracted from Air Combat Command Regulation (ACCR) 50-25, dated 4 January 1993.

- To the maximum extent possible, training is scheduled on an integral crew basis.
- Crew members should normally receive one MPT training period per month.

ACCR 55-66, dated 26 March 1993, lists the following priorities. The regulation states that the availability of resources determines the unit's ability to meet operational requirements and to apply these priorities:

- Priority I Alerts
- Priority II Training
- Priority III Higher Headquarters directed missions/exercises

Other possible objectives were used in the survey conducted at Malmstrom AFB. The average values of the objectives presented in the survey are listed in rank order in Table 3.1 (Dalton, 1994;41). These numbers may lead to false conclusions concerning the importance of any individual objective. As mentioned earlier, leave and e-days are the only objectives which were deemed statistically significant. However, every objective was deemed important by at least some crew members since no average values equaled zero. Also, the objective which sets a goal of at least one MPT a month is directed in a regulation and yet, it is not deemed statistically significant. Table 3.2 shows that the opinions of the most seasoned crew members/staff officers, Operations Flight Commanders, vary dramatically.

The regulations give clear guidance for the basics: cover all the alerts, accomplish all the training possible, and then accomplish everything else. The ambiguity arises over the weighting of the alerts, training, and other activities. To solve this problem, all thirteen objectives listed in this chapter are incorporated in the heuristic. However, only a fraction of these are formally tracked as measures of effectiveness used to compare one

schedule to another. The measures chosen are discussed in Chapter IV. The heuristic does not schedule MPTs, so the objective to have at least one MPT for each crew member in each month is not accomplished directly. However, since MPTs are seen as inputs to the algorithm, it will not change or delete any prescheduled MPTs. If each crew member is scheduled for one MPT, the heuristic must honor these requests and build crew member schedules around their scheduled MPT.

It is important to note that the priorities listed in ACCR 55-66 do not dictate the order in which events are scheduled. In order to support all the objectives effectively, training days are scheduled first. This scheduling is done around all prescheduled events such as TDY, leave and e-days. Then the alerts and backups are scheduled. The reason training days are scheduled before alerts and backups is because there are fewer potential class days, usually between eight and 15, than days when alerts have to be covered. Crew members can have a feasible schedule without any alerts, but their schedule is infeasible without the required monthly training. A detailed description of the scheduling heuristic is contained in Chapter IV.

Table 3.1 Ranked Survey Results

Rank	Average value	Objective
1	21.15	Leave
2	15.46	e-days
3	12.68	Integral alerts
4	11.94	X-days
5	11.92	At least one MPT a month
6	10.65	Workload Equalization
7	8.77	Squadron Integrity
8	7.43	SCP crews getting at least one SCP alert a month

Table 3.2 Operations Flight Commanders Survey Results

Ops Flight Commander	Integral Alerts	Squadron Integrity	Workload Distribution	X-days	e-days	Leave	1 MPT Month	1 SCP Alert
1	.00	.00	70.00	.00	20.00	10.00	.00	.00
2	20.00	6.00	15.00	8.00	9.00	18.00	20.00	4.00
3	20.00	20.00	5.00	.00	.00	25.00	25.00	5.00
4	5.00	.00	.00	20.00	20.00	30.00	10.00	15.00
5	15.00	.00	5.00	20.00	20.00	20.00	15.00	5.00
Average	12.00	5.20	19.00	9.60	13.80	20.60	14.00	5.80
Standard Deviation	9.08	8.67	29.03	10.04	9.07	7.54	9.62	5.54

Decision Variables

For each day monthly training is offered, a decision must be made whether or not to schedule a particular crew member for class on that day. A crew member can only be scheduled for one recurring training class on any given day. If both classes, T1 and T3/4, are offered on the same day, and a crew member is to be scheduled for a class on that day, a decision must be made concerning which class to schedule. Whether or not to schedule a crew member for alert is another decision which must be made for each day. If a crew member is scheduled for alert, the next determination is the LCF where the alert is scheduled. Also, a crew member can be scheduled to a backup alert crew rather than to an LCF.

Constraints/Rules

Rules which govern the scheduling of missile crew members come from many sources. The heuristic used to schedule crew members must comply with each rule. Some of the rules which generate constraints for the problem are contained in ACCR 50-25. Following is a list of the these rules.

1. Crew members will accomplish recurring training requirements beginning in the first calendar month after EWO certification.
2. When a crew member enters upgrade training, recurring training requirements are waived until EWO certification in the new crew position.

The next set of rules is from ACCR 55-66.

3. Crew members should be allowed a minimum of 12 hours of crew rest before reporting for alert duty. Under unusual circumstances, the operations group commander may place crew members on alert with a minimum of eight hours of crew rest.
4. Under normal conditions, line crew members will perform no more than eight alert actions per month.
5. Under normal conditions, TEF crew members will perform no more than three alert actions per month.
6. Under normal conditions, DOT crew members will perform no more than two alert actions per month.
7. Under normal conditions, DOV crew members will perform no more than two alert actions per month.
8. Crew members are granted Combat Crew Rest and Recuperation (CCRR) for alert duty. The CCRR period will be equal to at least 50% of the total alert time.
9. Alert tours at SCPs will be performed only by crews trained specifically in SCP duties and procedures.
10. Do not schedule back-to-back alert tours unless requested in writing by the crew member and approved by the appropriate squadron commander (A back-to-back alert means going out on alert, coming home on the next day and going out on alert the following day).

Additional rules are listed in SAC Manual 171-104 Volume I.

11. Any combination of five days of leave and TDY equal one alert.
12. Each day of alert is followed by CCRR. This is shown on the schedule as O.
13. There must be two days between alerts and backups.
14. Nothing must be scheduled after 1900 hours on the day prior to alert duty.
15. Alerts are not scheduled one day prior to leave or TDY.
16. Alerts are not scheduled two days prior to, or after, alerts or backups.

If all alerts cannot be covered using the recommended number of alerts, a set of rules must be in place to determine which crew members are assigned the additional alerts. Each OG commander has the latitude to change the distribution of additional alerts at any time. This means the constraints governing the distribution of additional alerts must be easily changed by wing schedulers to reflect the current policy concerning additional alert distribution.

Many other rules are derived because of timing restrictions. For example, a crew member cannot be scheduled for T1 and T3/4 on the same day because the classes meet at the same time. The only thing that is systematically scheduled on the same day as T1 or T3/4 is an evening event such as an academic class or a requested evening off. Though some late MPT sessions can be scheduled on the same day as T1 or T3/4, this is not done routinely; however, there is no rule against it.

Preprocessing

Looking only at scheduling alerts and backups, the problem of determining which days are viable days to schedule a crew member for an alert or backup is complex. However, the problem's structure permits a considerable amount of preprocessing. This means a set of rules can be applied to the days before and the days after a day which is being considered for an alert. If all the conditions are satisfied, the day can be marked to indicate it can be used for an alert or backup. If the inputs given to the wing schedulers can be preprocessed so days where a crew member is capable of pulling alert or backup are identified, the complexity of generating a monthly schedule for the entire wing is greatly reduced. Using a spreadsheet, many of the rules that govern scheduling alerts and backups can be combined into six categories. The categories are listed in Table 3.3.

A spreadsheet is used to search the inputs for a given crew member to see if events falling in these categories exist. If the event is something which would prevent the crew member from being scheduled for alert, it is flagged. If all the checks are made on the days from two days before a targeted day through two days after a targeted day, and no events are found which would prevent an alert or backup from being scheduled, then the day is marked as a potential alert/backup day. Otherwise, the day is marked as a day on which pulling alert/backup is not a valid event for the crew member.

Table 3.3 shows the categories of events which affect the scheduling of alerts and backups. The events in each category are determined by the user in conjunction with current scheduling policies and regulation requirements. If changes arise to the current

policies or regulations, the user can change the entries within the spreadsheet and let the preprocessor implement the new rules.

Table 3.3 Categories of Events for Scheduling Alerts and Backups

Category Number	Category
1	Events which <u>Cannot</u> be Done 2 Days Prior to Alert or Backup
2	Events which <u>Cannot</u> be Done 1 Day Prior to Alert or Backup
3	Late MPT sessions 1 Day Before Alert or Backup
4	Events that <u>Can</u> be Done the Day of Alert or Backup
5	Events that <u>Can</u> be Done 1 Day After Alert or Backup
6	Events which <u>Cannot</u> be Done 2 Days After Alert or Backup

Events which currently affect the viability of a day for alert consideration are contained in Figure 3.1. Each alert is shown as an “A” followed by the lowercase letter of the LCF where the alert is to be performed. A backup is designated as a “B”, a day of leave is designated as an “L”, and an e-day is an “E”. The numbers in category 3 are the starting times for MPT sessions. The longest MPT session at any missile wing is five hours. If no MPT sessions are scheduled after 1400 on the day before an alert or backup is potentially scheduled, then the rule governing event scheduling after 1900 the day before an alert or backup is not violated. Category 4 does not have any entries listed

because currently there are no events which can be scheduled the same day as an alert.

The letters used for the LCFs in this example are “a” through “o”.

Category Number	Events																	
	B	Aa	Ab	Ac	Ad	Ae	Af	Ag	Ah	Ai	Aj	Ak	Al	Am	An	Ao		
1	L	O	B	Aa	Ab	Ac	Ad	Ae	Af	Ag	Ah	Ai	Aj	Ak	Al	Am	An	Ao
2	14	15	16	17	18	19	20											
3																		
4	E																	
5	B	Aa	Ab	Ac	Ad	Ae	Af	Ag	Ah	Ai	Aj	Ak	Al	Am	An	Ao		
6																		

Figure 3.1 Events Contained in Preprocessing Example

Preprocessing Example. Figure 3.2 is an excerpt of a crew member’s schedule which shows how preprocessing is done using a spreadsheet. Preprocessing decreases the number of operations required in an algorithm used to solve the scheduling problem. Each day of the month is represented, along with the last two days of the previous month and the first two days of the next month. These extra days are needed to ensure there are no conflicts such as scheduling someone for an alert on the first when they just came off alert on the last day of the previous month. Many aspects of preprocessing are illustrated for the days shown.

First, if Smith should be scheduled for an alert on the 22nd, there is a conflict with what can be done one day after an alert or backup. The only valid entry is an e-day and he has an MPT session at 0700 on the 23rd (shown as A07Q). Since this will eliminate the possibility of an alert, a “1” is entered by the spreadsheet for the row representing a conflict the day after a potential alert. The spreadsheet sums the six rows of the column

below the three rows containing the events for the crew member. If this sum is greater than zero, as in the case of day 22, a “0” is entered in the last row. If the sum of these entries were zero, a “1” would be entered in the last row. A one in the last row indicates this is a feasible day for an alert or backup.

	Day	22	23	24	25	26	
First	Last						
John	Smith		A07Q			I01	
John	Smith					FO	
John	Smith						
John	Smith	0	0	0	0	0	Two days Prior to Alert
John	Smith	0	0	0	0	0	One Day Prior to Alert
John	Smith	0	0	0	0	0	Late Night Trainer
John	Smith	0	1	0	0	1	Day of Alert
John	Smith	1	0	0	1	0	One Day After Alert
John	Smith	0	0	0	0	0	Two days After
John	Smith	0	0	1	0	0	Available for Alert or B

Figure 3.2 Example Preprocessing Crew Member Schedule

Looking at the 23rd, the 0700 MPT eliminates this day for consideration, so a “1” is entered for the row indicating everything is not clear the day of the potential alert. The sum of the six rows is greater than zero, so a “0” is entered in the last row indicating this day does not meet the requirements for scheduling an alert or backup. Day 24 does not have any conflicts and thus has zeros in the first six rows, so a “1” is entered in the last row. The “1” indicates Smith can be scheduled for alert or backup on this day. It is important to realize that all these calculations are done by the spreadsheet, and the algorithm only has to be concerned with the days that are valid when it is attempting to

schedule alerts and backups. This greatly reduces the number of calculations and checks the new algorithm must accomplish, and thus reduces the solution time. The new algorithm, is the computer code that creates schedules. The heuristic is the entire scheduling process, including the computer code and the spreadsheets used to do the preprocessing.

Summary

This chapter described the objectives, decision variables, and the constraints of the missile crew scheduling problem. Then a method of preprocessing the inputs was described, followed by an example of how the preprocessing works. The next chapter provides details of each part of the heuristic.

IV. The Improved Heuristic

Overview

This chapter describes how the rules explained in Chapter III are implemented in the new heuristic. This chapter also describes the execution of the spreadsheets and computer code developed to assist the wing and squadron schedulers in the process of generating monthly schedules. The data inputs and their preprocessing is discussed, the logic used to schedule crew members is presented, and the output is explained. Additional details can be found in the user's manual in Appendix C.

Scheduling Objectives

Table 4.1 displays each scheduling objective along with the ways it is supported and measured. If the objective is supported through the logic of the new algorithm, then a "Yes" is in the logic column. This means the new algorithm supports the objective as it builds a schedule. If an objective is supported as an input, then the new algorithm will schedule around the associated event which has been entered as an input. Statistics are calculated for measures of effectiveness which are so designated in Table 4.1. Descriptions of the measures of effectiveness, for each objective that has a measure, are also presented in Table 4.1

Table 4.1 Objective Attributes

Objective	Logic	Input	Effectiveness Measure	Measure Description
Integral Crew Training	Yes	Yes	No	
1 MPT per Month	No	Yes	No	
Cover all Alerts/Backups	Yes	Yes	Yes	Number of Alerts/Backups Not Covered
Training	Yes	Yes	Yes	Number of crew members without T1 or T3/4 scheduled
Missions/Exercises	No	Yes	No	
Leave	No	Yes	Yes	Total number of Leave days in schedule
Education days	No	Yes	Yes	Total number of e-days in the schedule
Integral Alerts	Yes	Yes	No	
X-days	No	Yes	Yes	Total number of X-days in schedule
Workload Equalization	Yes	Yes	No	
Squadron Integrity	Yes	Yes	No	
SCP Crews with 1 SCP Alert	Yes	Yes	No	

The New Scheduling Heuristic

The new scheduling heuristic has three parts: inputs, computer code (referred to as the new algorithm), and output. The inputs are prescheduled events and basic information such as crew position, flight and squadron which are consolidated and preprocessed by spreadsheets. The computer code contains the new scheduling algorithm. It reads in the inputs contained in the spreadsheets and generates a schedule and other output, such as an audit trail of how the schedule was built, and statistics describing the schedule which was generated. Wing schedulers can manipulate the generated schedule, thus producing the final schedule. If wing schedulers are not satisfied with the schedule produced by the new algorithm they can manipulate the inputs and run the new algorithm again. The schedulers can then choose a schedule from those produced and accomplish

any modifications needed to generate the final schedule. Figure 4.1 depicts the entire process.

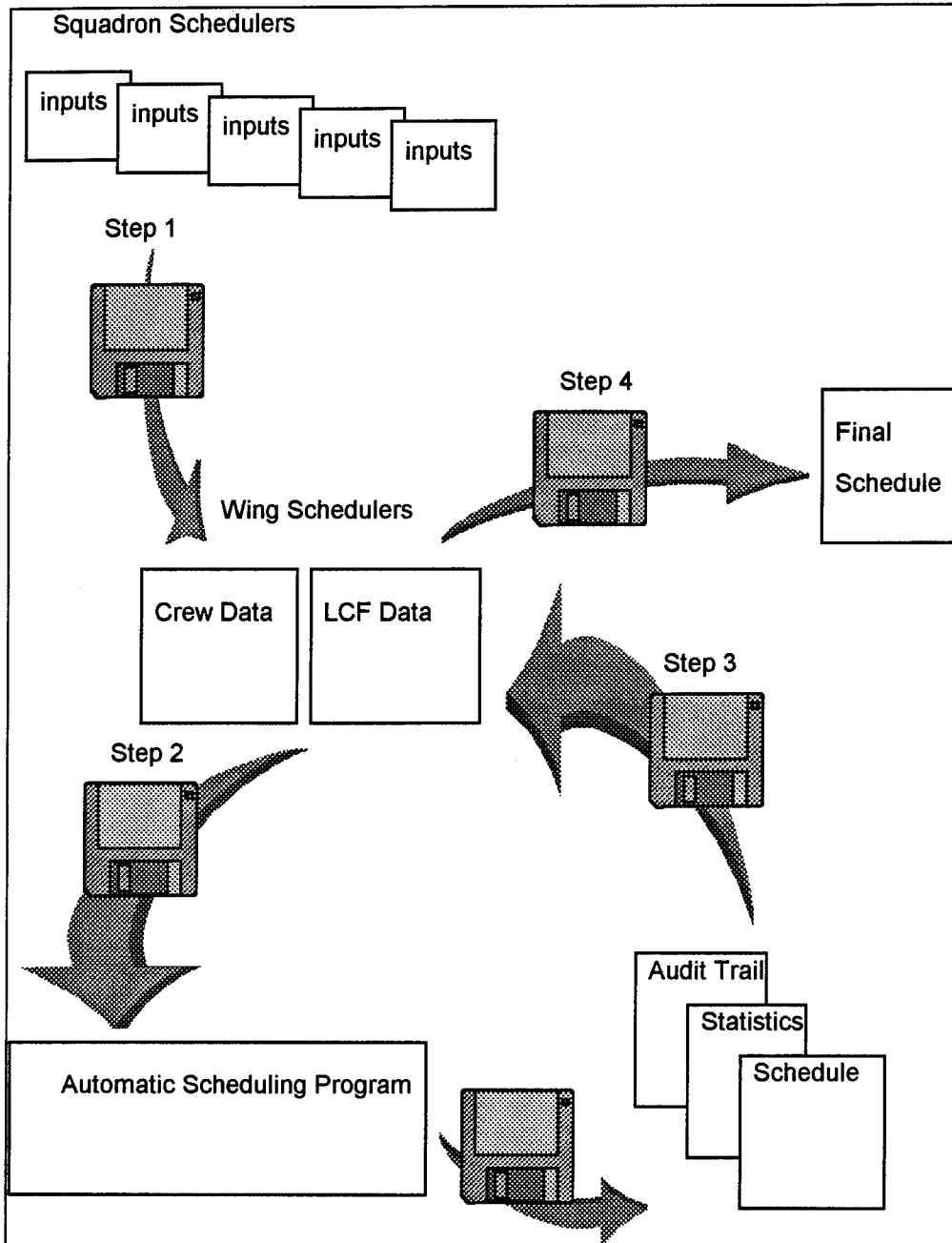

Figure 4.1 Scheduling Process Overview

The New Algorithm

Each of the three aspects of the scheduling heuristic are explained. The relationship between the inputs, output and the new algorithm is described in detail.

Inputs. In order to build a schedule, the new algorithm needs detailed information concerning the crew members who need to be scheduled and the LCFs where the crew members are to be scheduled. The information for the crew members is consolidated in a spreadsheet which is arranged so squadron schedulers can quickly enter pertinent information for each crew member. Some of the information entered for each crew member is shown in Table 4.2.

Table 4.2 Inputs Made by Squadron Schedulers

Information Concerning Crew Member
Organization
Flight
Crew Number
Crew Position
Name
Whether or not the crew member is SCP-Qualified
Events Scheduled as Inputs (Leave, e-days, TDY, etc.)
Job
Weapon System
Special Qualifications

For each crew position, the new algorithm also needs information concerning how many alert actions can be assigned to each crew member. Table 4.3 contains the inputs concerning how alerts are distributed. The new algorithm attempts to schedule all the alert actions based on the user defined levels for various job types listed under iteration 1. If all the alerts and backups are scheduled using these levels, the new algorithm is finished. However, if some alerts or backups are not covered at these levels, the new algorithm attempts to schedule the unscheduled alerts by using the alert levels under iteration 2. No alerts which are scheduled during previous iterations are changed during subsequent iterations. Since the number of alert actions per job position remains unchanged or increases at each iteration, the new algorithm is given more latitude to schedule additional alerts as the number of iterations increases. The way additional alerts are distributed is completely dependent on the levels the user deems appropriate. This also supports the objective of leveling the workload distribution between like crew members. For example, all DOT crew members are considered for two alerts during iterations 1 through 4 before any DOT crew members are considered for three alerts at iteration 5.

Table 4.3 Alert Distribution Matrix

	Iteration														
Job	1	2	3	4	5	6	7	8	9	10	11	12	13	14	15
DOT	2	2	2	2	3	4	4	4	5	5	6	6	6	7	8
DOV	2	2	2	2	3	4	4	4	5	5	6	6	6	7	8
FL	6	7	8	8	8	8	8	8	8	8	8	8	8	8	8
LINE	7	8	8	8	8	8	8	8	8	9	9	9	9	9	9
OPC	2	2	2	2	2	2	3	4	4	4	4	5	6	7	8
TEF	2	2	3	3	3	4	4	4	5	5	6	6	6	7	8
Total	21	23	25	25	27	22	23	24	27	28	31	32	33	37	49

Once each squadron scheduler has collected the information for the crew members in their squadron, this information is sent to wing scheduling. Wing schedulers then consolidate this information. A spreadsheet is used to manage the collection and consolidation of the information. The consolidated information is then sorted so crew members are in order from those with the least flexible schedules to those with the most flexible schedules.

This is done by using the results of the data preprocessing stage. The total number of days a crew member is available to pull an alert or backup is calculated during preprocessing. The number of alerts a crew member should accomplish for their job type is obtained from the first iteration of the decision matrix displayed in Table 4.3. The number of alerts a crew member should accomplish is subtracted from the number of days the crew member is available for alert/backup. This is done to determine the order in which crews should be scheduled. For example, suppose there are two crew members. Each has 10 possible days for alert/backup, and one is a Line commander and the other is a TEF commander. Now, the number of alerts specified for the first iteration is seven for a Line commander and two for a TEF commander; so the result of the subtraction yields values of three for the Line commander and eight for the TEF commander. This means the Line commander has less flexibility. When the sort is accomplished, the information for the Line commander's schedule is presented to the new algorithm before the TEF commander's information. This ensures crew members with the least flexibility have their schedules constructed prior to crew members with fewer restrictions.

Another set of inputs is information about the LCFs where crew members may be required to pull alerts. The manipulation of this information is done solely by the wing schedulers. The information contained in LCF spreadsheets is listed in Table 4.4. Information concerning backups is also included. The drive time and mileage for a backup

is always zero. Again, a spreadsheet is used to collect information. A copy of an actual LCF spreadsheet is contained in Appendix D.

Table 4.4 LCF Information Entered by Wing Schedulers

Information Concerning Launch Control Facilities
Round Trip Miles
One Way Drive Time
Rank of Drive Time Within the Squadron
Rank of Drive Time Within the Wing
Whether or not SCP Qualification is Required
Weapon System
Type of Additional Qualification Required, if any
LCF Alert Name
Squadron
Number of Crew Members Required at Each LCF Each Day

Details of the New Algorithm

T3 and T4 are accomplished at different times on the same days, so they are scheduled as one event, T3/4. The new algorithm can be used to schedule any combination of T1s, T3/4s, and alerts/backups. Any combination of which can be selected by the wing scheduler. It is best to examine the new algorithm for the situation when all items are scheduled. However, the new algorithm flow only differs slightly if a subset of the three items is chosen. This is the most efficient use of the new algorithm since the algorithm makes logical decisions when selecting which days each crew member is to be

scheduled for recurring training (T1 and T3/4). Figure 4.2 is an overview of the algorithm flow. As previously mentioned, the decision concerning the order in which the events T1, T3/4, and alerts/backups are scheduled is important. They are scheduled in the order displayed because of the number of days each event is offered. At most missile wings, T1 is offered fewer times than T3/4, and since alerts/backups are required each day, there is more flexibility if alerts/backups are scheduled last. A detailed overview of the last four steps shown in Figure 4.2 is displayed in Figure 4.3. Each major step of the new algorithm is explained in the remainder of this chapter.

Requirements to be Met. The first four steps of the new algorithm presented in Figure 4.2 determine which events have already been scheduled and which events need to be scheduled. When the new algorithm determines how many crew members are prescheduled for a specific T1 or T3/4 class, it subtracts this number of seats from the total number of seats available for that class on that day. This ensures the class size limits, which are entered by the wing schedulers, are not violated. The new algorithm will not schedule crew members for a class that has no seats available. When a crew member is scheduled for an alert or backup by a squadron scheduler, this is an input that must be tracked. The new algorithm determines which alerts and backups have been prescheduled by the squadron schedulers so it will not attempt to schedule an additional crew for the same alert or backup.

Scheduling Recurring Training. The logic for scheduling recurring training is the same for T1 and T3/4 classes and is shown in Figure 4.4. The crew members are listed in order, from those with the most restrictive requirements to those with the least restrictive requirements. This order is determined when the inputs are preprocessed. Starting with the crew member having the most restrictive prescheduled requirements, the algorithm determines if they already have been scheduled for the training class. If so, the next crew member is selected from the list.

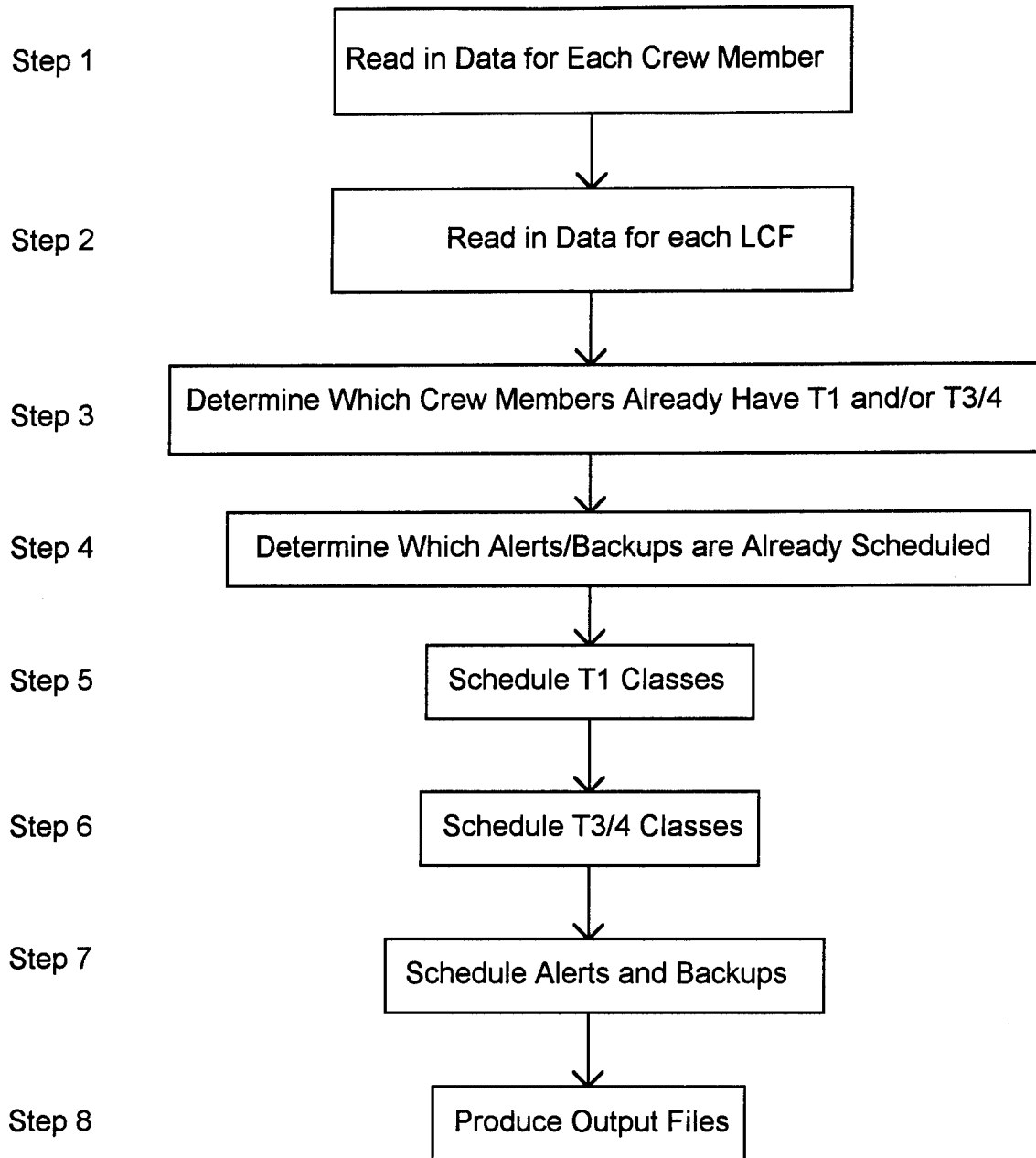

Figure 4.2 Algorithm Overview

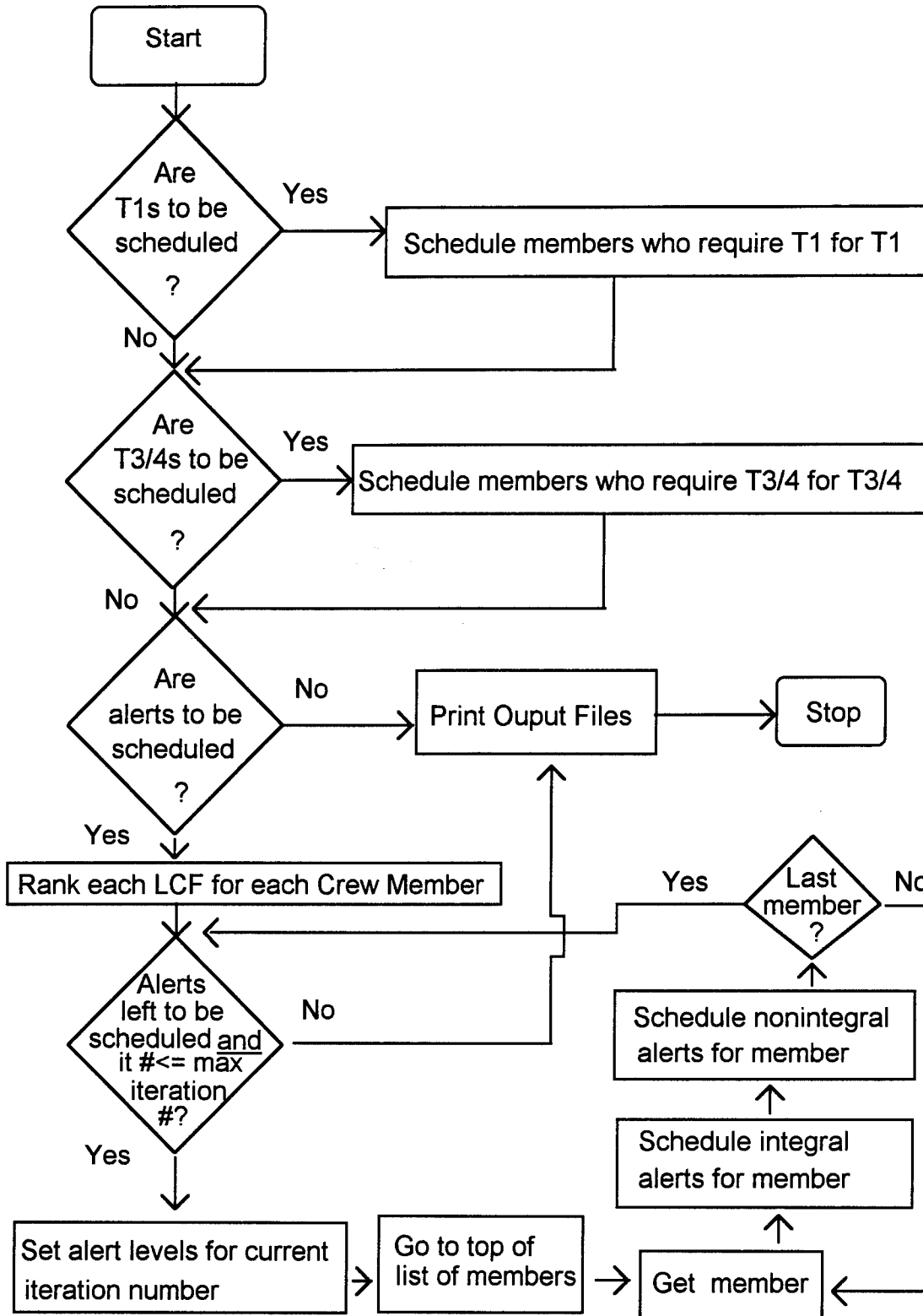

Figure 4.3 Detailed Algorithm Overview

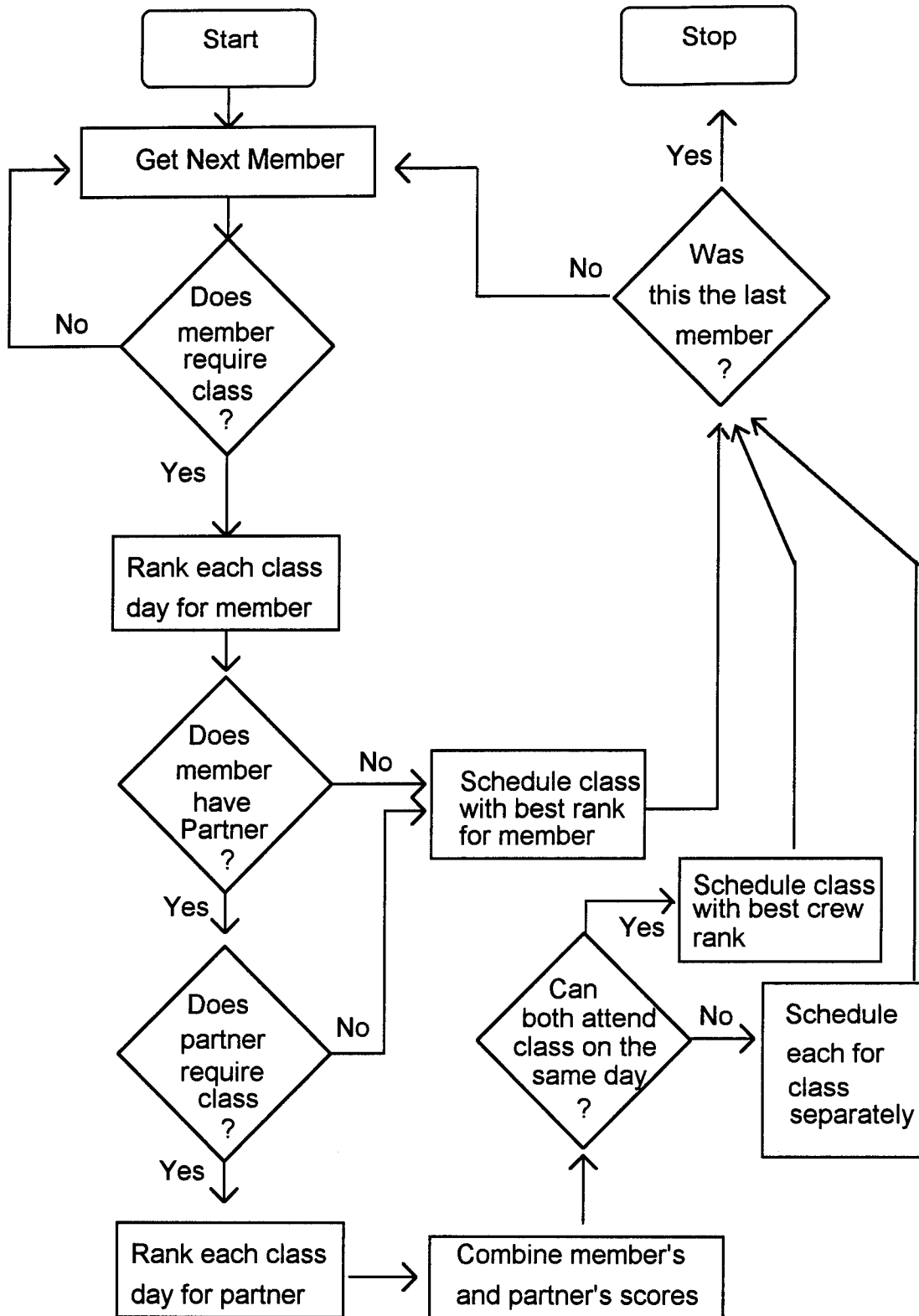

Figure 4.4 Flow of Class Scheduling Procedure

Once a crew member is found who requires the class, each day the class is offered is ranked. The ranking is based on the number of potential alert days a crew member will lose if the training is accomplished on that class day. If a crew member has a conflict on the day a class is offered, then this day is not ranked since the crew member is unable to attend class on that day. If a crew member will not lose any potential alert days, then this is the best day for them to attend class since it will not interfere with alerts and backups which are scheduled later.

Now, when both the crew commander and the deputy require the class, each class day is ranked for each crew member separately. The days which both crew members' schedules are clear for class are determined, and the class day which will lose the least total possible alert days, for the crew, is selected. When crews are being scheduled, only those class days with two or more seats available are considered. If there is a tie for the best day for class, the new algorithm determines which class day has the most seats available and schedules the crew member for class on that day. This helps keep the number of students scheduled for each class session equal. If there is no day which is available for both crew members to attend class together, then each is scheduled separately. Similar rules are followed when scheduling crew members separately. By attempting to schedule crew members as crews first, the objective of scheduling crews for integral training is supported.

Scheduling Alerts and Backups. Scheduling alerts and backups can be separated into three phases: ranking the LCFs; scheduling integral alerts/backups; and scheduling non-integral alerts/backups. In the first phase, each LCF is ranked for each crew member. This ranking determines which LCF is chosen for an alert given the attributes of a crew member. The computation of the rankings is done only once for each crew member.

Ranking Launch Control Facilities. The rank of an LCF, for a particular crew member, depends on the job title of the crew member. There are three sets of rankings which are based on a crew member's job title. The first is used for DOV and DOT crew members, the second is used for TEF crew members, and the last is used for everyone else. The full breakdown of the rankings are contained in Table 4.5.

When ranking an LCF, if the crew member does not have the proper qualifications needed to pull an alert at a given LCF, the rank of that LCF for that crew member is zero. If an LCF is designated as an SCP and the crew member is not SCP-qualified, then the rank for that LCF for that crew member is zero. This is also true for the Weapon System designation. If the Weapon System designation of an LCF is MIII (Minuteman Three), and a crew member is designated PK (Peacekeeper), then the rank for that LCF for that crew member is zero. The Special Qualifications designated for an LCF and the Additional Qualifications for a crew member are ranked in a fashion similar to that of the SCP qualification. The Special Qualification for an LCF is the minimum Special Qualification required, and if this is blank, then no Special Qualification is required. If a crew member has an Additional Qualification and the Special Qualification for an LCF is blank, they can still pull alert at the LCF as long as the Weapon System and SCP requirements are met. This is the same logic which allows SCP-qualified crews to pull non-SCP alerts. If there is a Special Qualification required for an LCF, then only crew members who have the Additional Qualification which matches it are deemed qualified to pull alert at that LCF. The ranks are structured so the higher the rank, the more preferable it is to send a crew member to a particular LCF. If a crew member does not have the minimum required qualifications for an LCF, the rank for that LCF is zero. The flow of the LCF ranking procedure is displayed in Figure 4.5.

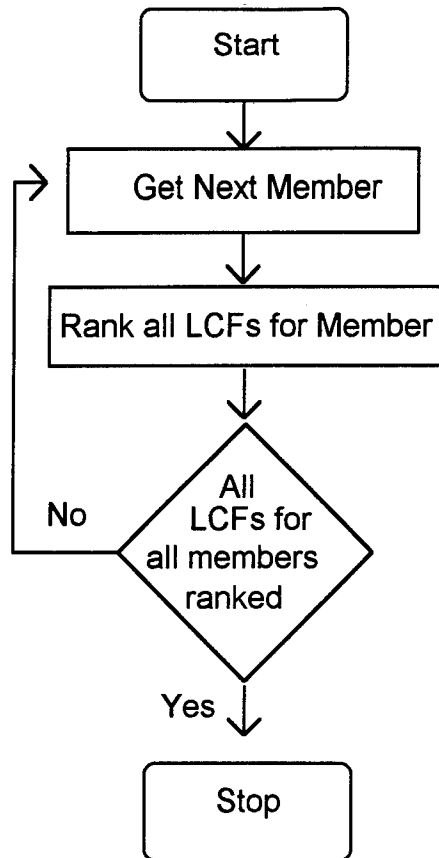

Figure 4.5 Flow of LCF Ranking Procedure

There is a large variance between the driving times LCFs at some missile wings. For example, one-way drive times at Malmstrom AFB range from 30 to 180 minutes. To help equalize the time crew members spend driving when they are not going to their home LCF, each LCF is ranked within their squadron and within the wing as either close or far. What constitutes whether or not a LCF is far from the Air Force base is an arbitrary decision. The measure chosen to determine which LCFs are close is the seven LCFs with the shortest official drive times are close LCFs, and the remaining eight are far LCFs. The ranks in Table 4.5 determine which LCF is chosen for a crew member if multiple LCFs need a crew member for a given day. Most DOV and DOT crew members are SCP-qualified, so these crews are sent to SCPs whenever possible. This helps cover the SCP

alerts and supports the objective of getting each SCP crew at least one SCP alert a month. By sending them to far LCFs whenever possible, they help relieve the pressure on crews who are assigned to LCFs with long drive times.

Table 4.5 How Launch Control Facilities are Ranked

Job Title	LCF Attributes	Rank Value
DOV and DOT	SCP and Far from Base	4
	SCP and Close to Base	3
	Non-SCP and Far from Base	2
	Non-SCP and Close to Base	1
TEF	SCP Within Crew Member's Home Squadron	4
	SCP Outside Home Squadron	3
	Non-SCP Within Home Squadron	2
	Non-SCP Outside Home Squadron	1
Non-TEF Squadron	Home LCF	5
	Non-Home LCF Within Squadron and Home LCF Ranked Far, Potential LCF Close, or Home LCF Ranked Close, Potential LCF Far	4
	Non-Home LCF Within Squadron and Home LCF Ranked Far, Potential LCF Far, or Home LCF Ranked Close, Potential LCF Close	3
	Outside Squadron and Home LCF Ranked Far, Potential LCF Close, or Home LCF Ranked Close, Potential LCF Far	2
	Outside Squadron and Home LCF Ranked Far, Potential LCF Far, or Home LCF Ranked Close, Potential LCF Close	1

In a similar fashion, most TEF crews are SCP-qualified. However, TEF crew members are assigned to a particular squadron, so it is important for them to have SCP alerts and Squadron alerts. Their rankings reflect trying to accomplish both types of alerts. This also supports the objectives concerning SCP alerts and Squadron Integrity.

Non-TEF squadron crew members are assigned to a particular LCF within a squadron. Their rankings reflect trying to schedule them for alert at their home LCF, and if that is not possible, schedule them in their home squadron. Each LCF is ranked within the squadron in relation to drive times. Once again, crew members who are normally sent to close LCFs are sent to further LCFs within their squadron if they cannot go to their home LCF. If the non-TEF crew member cannot be scheduled within their squadron, the same drive time logic is applied outside the squadron.

Scheduling Integral Alerts/Backups. The order in which crew members have schedules built for alerts and backups is the same as that used for scheduling recurring training classes. The crew members with the most restrictions are scheduled before crew members with more flexibility. Since backups are a part of the LCF data, they are treated the same as normal alerts. The flow of the procedure used to schedule integral alerts/backups for one crew member is displayed in Figure 4.6.

When scheduling integral alerts, both the commander's and the deputy's schedules must be considered. The first requirement is to determine which days are viable for an alert or backup for both crew members. This is done by multiplying the arrays of 1s and 0s calculated when inputs were preprocessed. If a crew member's schedule is open for an alert there is a 1 for the array element for that day. Multiplying these two arrays, element by element, the result yields an array of 1s and 0s where the 1s represent days viable for both crew members. From this subset of possible days, the day which has the highest number of total deputy and commander alerts required to be scheduled is chosen. In the case of a tie, the earliest day is chosen.

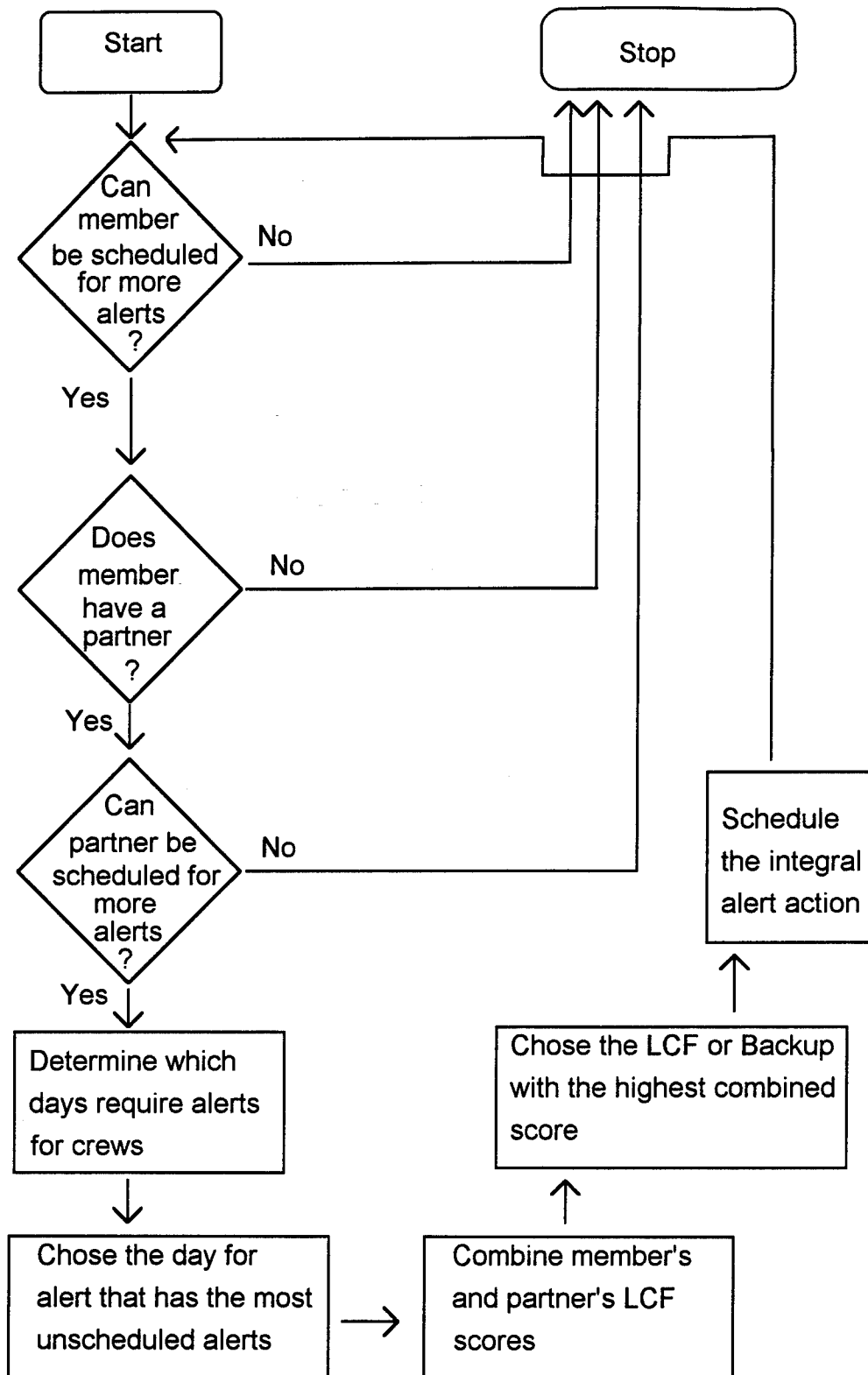

Figure 4.6 Flow of Integral Alert/Backup Procedure

Once the day has been chosen for an integral alert or backup, a particular LCF or a backup must be chosen. This is done in a manner similar to that for the day selection. By multiplying the arrays of LCF ranks for each crew member together, only the LCFs where both crew members meet all the qualification requirements will have nonzero ranks. This new array is then multiplied by the array which has the number of commanders required for that day for each LCF. This result is multiplied by the array which contains the number of deputies required for that day for each LCF. If an alert is covered, the number of commanders and deputies required will be zero. The final array will be a list of combined ranks for each LCF with a viable need for a crew and zeros otherwise. The LCF or backup with the largest rank is chosen and both crew members' schedules are updated. The two days prior to the alert and the two days after the alert will be eliminated from further consideration for additional alerts for both crew members.

The process of scheduling integral alerts is continued until there are no further integral alerts possible for the crew, or one or both of the crew members are at the limit for the number of alerts for the current iteration. The decision matrix shown in Table 4.3 dictates the limits for each iteration. These specific limits are determined by wing decision makers.

Scheduling Non-integral Alerts and Backups. The cases when non-integral alerts are scheduled are:

1. A crew member has no crew partner.
2. A crew member's crew partner is at the limit of alerts and they are not.
3. There are additional commander and deputy alerts required to be covered but the requirements are on different days.
4. All possible integral alerts are scheduled for a crew and one or both crew members still have viable days for alerts, they are under their alert limit, and there are still alerts to be covered.

The method used to schedule non-integral alerts is identical to the one used to schedule integral alerts. The only difference is the number of arrays multiplied. The flow of the procedure used to schedule non-integral alerts/backups for one crew member is contained in Figure 4.7. If a non-integral commander alert is to be scheduled, the viable days are those generated by the spreadsheet. The best day is selected by finding the day which has the most number of commander alerts required to be covered. Again, this helps keep the problem days to a minimum since the algorithm is always going to try to schedule the most challenging day first. This type of algorithm is called a greedy algorithm because it tries to satisfy short term requirements. The LCF is selected by multiplying the rank array for the particular commander with the requirement array for commander alerts for the chosen day. The commander is scheduled for alert at the LCF with the highest value, and the two days prior to and after the day scheduled are eliminated from further consideration. The process is exactly the same for non-integral deputies.

If the entire list of crew members is exhausted and there are alerts or backups which require crew members, the process is restarted. The new alert limits are those under the next iteration level of Table 4.3. All the alerts which have been scheduled are left in place and the unscheduled alerts are then scheduled using the new alert levels. This process continues until all 15 iteration levels have been used or all the alerts and backups are scheduled.

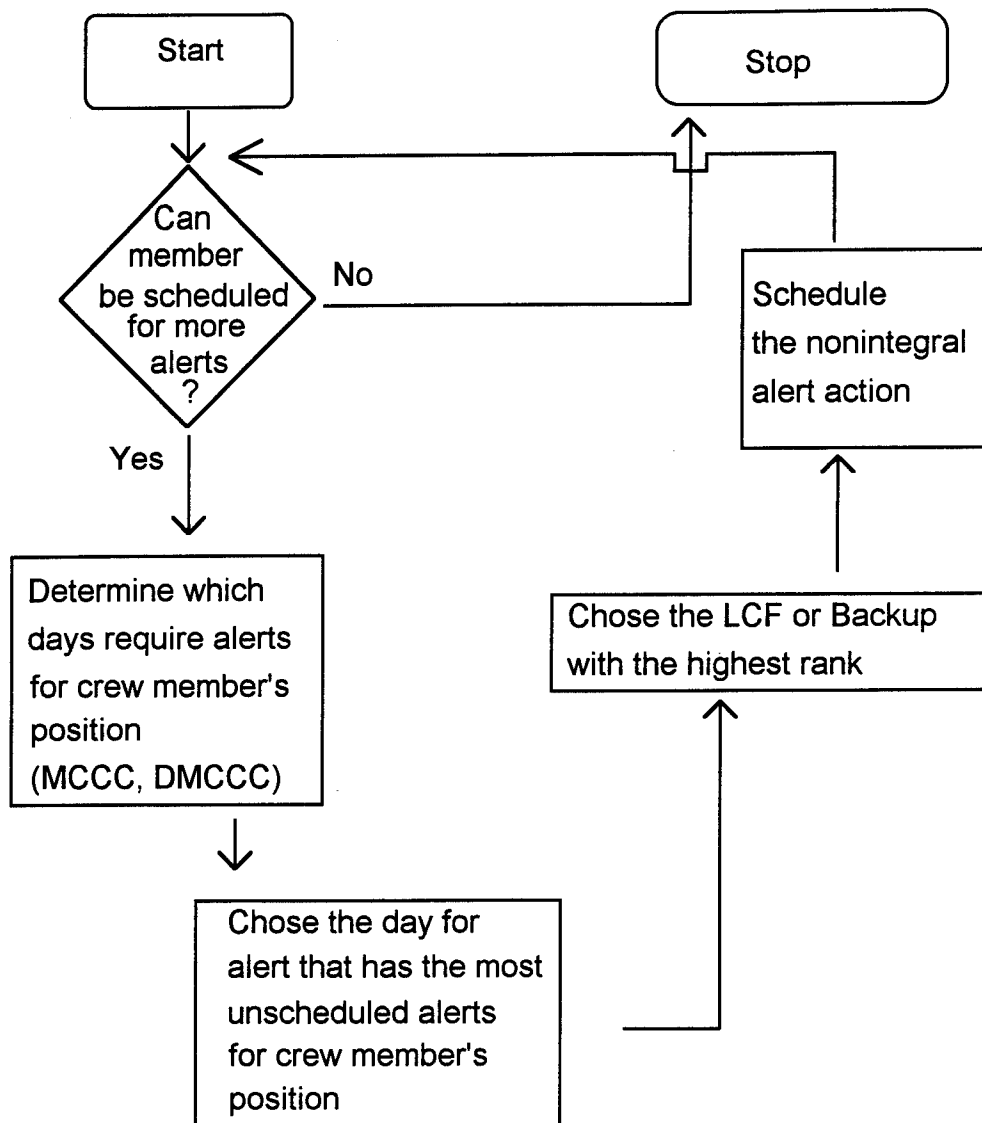

Figure 4.7 Flow of Non-integral Alert/Backup Procedure

Output. The output from the new algorithm is in the form of text files. The first output is a text file which keeps track of how the schedule is built. This file was used to debug the new algorithm and is still useful in that capacity. If schedulers enter data incorrectly, many of their errors can be pinpointed by looking at the last few lines of this file.

The next file the algorithm generates is a comma-delimited text file of statistics concerning the schedule which was built. This file displays a matrix for commander alerts and deputy alerts. A zero for an LCF on a given day indicates the alert is covered for that day. A nonzero number for an LCF means all alerts were not covered for that LCF on that day. The new algorithm does include the flexibility to schedule more than one crew for alert for a given LCF should the need arise. The file is created in a comma-delimited format so it can be quickly read into a spreadsheet and interpreted. A copy of this file, in spreadsheet form, is in Appendix E.

The last file is the actual schedule. This, too, is in comma-delimited form so it can be read by a spreadsheet. Once read by a spreadsheet, this file is copied into another spreadsheet which converts it into the form which is manipulated by wing and squadron schedulers. The intermediate spreadsheet calculates and displays the measures of effectiveness described in Table 4.1. A partial copy of this spread sheet is contained in Appendix F.

Summary

The flow of the new heuristic has been explained in this chapter. The process has been described from inputs and their preprocessing, through the logic used to schedule crew members for alerts/backups and classroom training, and the outputs generated by the new algorithm were presented. The next chapter will test the new algorithm using information from an actual missile wing.

V. Verification and Validation

Overview

This chapter describes the algorithm testing and the data set used in the testing. The data set is described in detail, along with modifications made to the data set at each phase of testing. The schedules generated are characterized by statistics, which include measures of effectiveness previously described. The results generated by the algorithm developed in this research and labeled the new algorithm in the remainder of this study, are then compared to the best case results of the old missile crew scheduling algorithm. This chapter concludes with a discussion of the results achieved by the new algorithm after being implemented at an operational missile wing.

The Test Data Set

A 31-day month was chosen as the test month. This would be the most demanding month for scheduling, since the longer the month, the more alerts and backups that need to be scheduled. Of the 31-day months, March was chosen because it traditionally is an "average" month in terms of leave and other required activities. Some months, such as December, July, and August, have more requested days of leave than other months. Often the number of academic days in March is higher than in the summer months, making the schedule slightly more difficult to generate than those with fewer academic days, all other inputs remaining the same.

The inputs used for the testing were those for actual crew members at Malmstrom AFB in March of 1994. The inputs squadron schedulers gathered and delivered to the wing schedulers at Malmstrom AFB where entered into the new algorithm. Each type of crew member and organization is represented. Some crew members had crew partners and some did not.

Only one weapon system was tested and this weapon system has three squadrons, one DOT section and one DOV section. This is representative of the most demanding weapon system configuration. All the LCFs are from the same weapon system and none required additional crew member qualifications. The test was accomplished with these parameters because the old algorithm does not handle additional qualifications.

A summary of information which is contained in the original data set is displayed in Table 5.1. Any item that is prescheduled is entered as an input before the new algorithm builds the schedule. The crew members that cannot be scheduled for any alerts or backups have medical or other problems which prevent them from performing alert duties. Many of these crew members are coded DNIA (Duties Not Including Alert). They can accomplish classroom training and MPT sessions; however, they cannot perform alerts or backups.

Table 5.1 Test Data Set Information

Item	
Required Meetings Prescheduled	Yes
MPTs Prescheduled	Yes
Total Number of Crew Members	200
Number of Crew Members with Automatic Scheduling Turned Off	6
Number of Crew Members Who Cannot be Scheduled for Any Alerts or Backups	11
Number of Crew Members Who Require T1	192
Number of Crew Members Who Require T3/4	186
Number of Days of Leave	346
Number of Academic Evenings	226
Number of DNIA Days	154

Testing

Each test was constructed in the same manner. The data set was input using the parameters described in each phase. The schedule was produced and statistics were gathered for each measure of effectiveness. Then the new algorithm was tested using the conditions under which the old algorithm operates. These conditions are: no backups, no T1 or no T3/4 classes are scheduled. The old algorithm is estimated to schedule 75% to 80% of the required alerts, no backups, no T1s, and no T3/4s (Wardle, 1993). Measures of effectiveness were calculated for the new algorithm and compared to those of the old algorithm. The old algorithm was assumed to schedule 85% of the required alerts, no backups and no classroom training. Eighty-five percent was used because the 75% to 80% estimates were not the results of an empirical study.

There were only 13 LCFs operational in March of 1994, so the total number of alerts and backups required for the first four phases is 868, for each phase. At an 85% efficiency rating, the old algorithm would have scheduled approximately 738 alerts with no backups, no T1s and no T3/4s scheduled. Since 806 alerts, 62 backups, and 378 days of classroom training were required the wing schedulers would have to manually schedule a total of 508 events after the old scheduling algorithm was complete.

In Phases V and VI the number of LCFs requiring alerts increases to 15. Again, at an 85% efficiency rating, the original algorithm would have scheduled approximately 791 alerts with no backups, no T1s and no T3/4s. Since 930 alerts, 62 backups, and 378 days of classroom training were required, the wing schedulers would have to manually schedule a total of 579 events after the old scheduling algorithm is complete for Phases V and VI.

Phase I. The inputs for this phase were the original inputs of the squadron/division schedulers with one minor modification. The missile wing at Malmstrom AFB schedules a training verification (TV) day after a crew member has been on leave or TDY for an extended period of time. This is a valid local procedure, but it is

not required. These TV-days were deleted from the original inputs to ensure the tests were not Malmstrom AFB peculiar. The parameters for the tests accomplished in Phase I are displayed in Table 5.2.

The schedules produced by the new algorithm yielded the results in Table 5.3. Experiment 1 uses the full capabilities of the new algorithm, alerts, backups, T1s and T3/4s are scheduled. There were only 15 required events left to manually schedule after the new algorithm produced the schedule for Experiment 1. Experiment 2 only schedules alerts. This is accomplished in order to compare the results of the new algorithm with those of the old algorithm. When the new algorithm was used under the identical conditions that the old algorithm operates under, 100% of the alerts were scheduled.

Table 5.2 Inputs for Phase I

	Experiment Number	
	1	2
Number of Alerts Required	806	806
Number of Backups Required	62	0
Total Number of Alerts and Backups	868	806
Number of Prescheduled Alerts	50	50
T1s Scheduled	Yes	No
Number of T1 Classes	8	0
T1 Class Size	40	0
T3/4s Scheduled	Yes	No
Number of T3/4 Classes	9	0
T3/4 Class Size	35	0
Number of TDY Days	71	71
Number of X-days	106	106

Table 5.3 Output Results for Phase I

	Experiment Number	
	1	2
Number of Alerts and Backups Scheduled	853	806
Number of Alerts and Backups Not Scheduled	15	0
Percentage of Alerts and Backups Scheduled	98.3	100
Number of Crew Members who Require T1 not Scheduled	0	192
Number of Crew Members who Require T3/4 not Scheduled	0	186
Computer Run Time (Seconds)	35	24
Total Number of Required Events Not Scheduled	15	378

Phase II. In March 1994 the wing schedulers allowed more alerts to be prescheduled than their current policy allows. No alerts are required to be prescheduled by any regulation; however, some alerts involving evaluations and training are routinely prescheduled to avoid conflicts once the schedule is built. Other prescheduled alerts were allowed for some crew members. In this phase, the Phase I parameters were used with the exception of prescheduled alerts. In Phase II, and in all subsequent phases, only alerts involving training and evaluations are prescheduled. The inputs for Phase II are displayed in Table 5.4.

The schedules produced by the new algorithm yielded the results shown in Table 5.5. Experiment 3 uses the full capabilities of the new algorithm and schedules alerts, backups, T1s and T3/4s. There were only 18 required events left to manually schedule after the new algorithm produced the schedule for Experiment 3. Experiment 4 only schedules alerts. This is accomplished in order to compare the results of the new algorithm with those of the old algorithm. When the new algorithm was used under the identical conditions that the old algorithm operates under, 99.9% of the alerts were scheduled.

Table 5.4 Inputs for Phase II

	Experiment Number	
	3	4
Number of Alerts Required	806	806
Number of Backups Required	62	0
Total Number of Alerts and Backups	868	806
Number of Prescheduled Alerts	40	40
T1s Scheduled	Yes	No
Number of T1 Classes	8	0
T1 Class Size	40	0
T3/4s Scheduled	Yes	No
Number of T3/4 Classes	9	0
T3/4 Class Size	35	0
Number of TDY Days	71	71
Number of X-days	106	106

Table 5.5 Output Results for Phase II

	Experiment Number	
	3	4
Number of Alerts and Backups Scheduled	850	805
Number of Alerts and Backups Not Scheduled	18	1
Percentage of Alerts and Backups Scheduled	97.9	99.9
Number of Crew Members who Require T1 not Scheduled	0	192
Number of Crew Members who Require T3/4 not Scheduled	0	186
Computer Run Time (Seconds)	35	38
Total Number of Required Events Not Scheduled	18	440

Phase III. In this phase the same parameters for Phase II were used with the exception of the number of X-days allowed for each crew member. Local guidelines at Malmstrom AFB allow a maximum of three X-days for each crew member each month. Every X-day allowed in the schedule means the crew member cannot be scheduled for alert on that day, or the day prior to the X-day. Also, training is not accomplished on X-days. There are no mandates requiring wings to allow crew members to have X-days.

Because the number of X-days allowed is determined at the local level, for Phase III the maximum number of X-days allowed per crew member is limited to one. Some missile wings do not allow any X-days to be entered, while others allow X-days provided they are one of the first items dropped from the schedule when mission requirements cannot be accomplished. The inputs for Phase III are displayed in Table 5.6.

The new algorithm produced the results presented in Table 5.7. Experiment 5 uses the full capabilities of the new algorithm and schedules alerts, backups, T1s and T3/4s. There were only 11 required events left to manually schedule after the new algorithm produced the schedule for Experiment 5. Experiment 6 only schedules alerts. This is accomplished in order to compare the results of the new algorithm with those of the old algorithm. When the new algorithm was used under the identical conditions that the old algorithm operates under, 803 or 99.6% of the alerts were scheduled.

Table 5.6 Inputs for Phase III

	Experiment Number	
	5	6
Number of Alerts Required	806	806
Number of Backups Required	62	0
Total Number of Alerts and Backups	868	806
Number of Prescheduled Alerts	40	40
T1s Scheduled	Yes	No
Number of T1 Classes	8	0
T1 Class Size	40	0
T3/4s Scheduled	Yes	No
Number of T3/4 Classes	9	0
T3/4 Class Size	35	0
Number of TDY Days	71	71
Number of X-days	40	40

Table 5.7 Output Results for Phase III

	Experiment Number	
	5	6
Number of Alerts and Backups Scheduled	858	803
Number of Alerts and Backups Not Scheduled	10	3
Percentage of Alerts and Backups Scheduled	98.8	99.6
Number of Crew Members who Require T1 not Scheduled	0	192
Number of Crew Members who Require T3/4 not Scheduled	1	186
Computer Run Time (Seconds)	36	38
Total Number of Required Events Not Scheduled	11	443

Phase IV. In this phase, the same parameters for Phase III were used with the exception of the number of X-days allowed for each crew member. In this phase and all subsequent phases, no X-days are allowed. Since they are not required by any regulation and some wings do not use X-days, this is a valid assumption. The inputs for Phase IV are displayed in Table 5.8.

Table 5.8 Inputs for Phase IV

	Experiment Number	
	7	8
Number of Alerts Required	806	806
Number of Backups Required	62	0
Total Number of Alerts and Backups	868	806
Number of Prescheduled Alerts	40	40
T1s Scheduled	Yes	No
Number of T1 Classes	8	0
T1 Class Size	40	0
T3/4s Scheduled	Yes	No
Number of T3/4 Classes	9	0
T3/4 Class Size	35	0
Number of TDY Days	71	71
Number of X-days	0	0

The new algorithm produced schedules results presented in Table 5.9. Experiment 7 exercises the full capabilities of the new algorithm and schedules alerts, backups, T1s and T3/4s. There were only 9 required events left to manually schedule after the new algorithm produced the schedule for Experiment 7. Experiment 8 only schedules alerts. This is accomplished in order to compare the results of the new algorithm with those of the old algorithm. When the new algorithm was used under the identical conditions that the old algorithm operates under, 100% of the alerts were scheduled.

Table 5.9 Output Results for Phase IV

	Experiment Number	
	7	8
Number of Alerts and Backups Scheduled	859	806
Number of Alerts and Backups Not Scheduled	9	0
Percentage of Alerts and Backups Scheduled	99.0	100
Number of Crew Members who Require T1 not Scheduled	0	192
Number of Crew Members who Require T3/4 not Scheduled	0	186
Computer Run Time (Seconds)	34	22
Total Number of Required Events Not Scheduled	9	440

Phase V. In this phase, the parameters are identical to those of Phase IV with the exception of the number of alerts required. In this phase and all subsequent phases, all 15 LCFs are operational. In March of 1994 only 13 LCFs were operational. Often, all 15 LCFs are operational and require crews. Testing using this case, provided the most challenging scenario for any potential month, since 31-days and 15 LCFs are required to be scheduled. The inputs for Phase V are displayed in Table 5.10.

The schedules produced by the new algorithm yielded the results presented in Table 5.11. Experiment 9 again uses the full capabilities of the new algorithm and schedules alerts, backups, T1s and T3/4s. There were 50 required events left to manually schedule after the new algorithm produced the schedule for Experiment 9. Experiment 10 only schedules alerts. This is accomplished in order to compare the results of the new algorithm with those of the old algorithm. When the new algorithm was used under the identical conditions that the old algorithm operates under, 923 or 99.2% of the alerts were scheduled.

Table 5.10 Inputs for Phase V

	Experiment Number	
	9	10
Number of Alerts Required	930	930
Number of Backups Required	62	0
Total Number of Alerts and Backups	992	930
Number of Prescheduled Alerts	40	40
T1s Scheduled	Yes	No
Number of T1 Classes	8	0
T1 Class Size	40	0
T3/4s Scheduled	Yes	No
Number of T3/4 Classes	9	0
T3/4 Class Size	35	0
Number of TDY Days	71	71
Number of X-days	0	0

Table 5.11 Output Results for Phase V

	Experiment Number	
	9	10
Number of Alerts and Backups Scheduled	942	923
Number of Alerts and Backups Not Scheduled	50	7
Percentage of Alerts and Backups Scheduled	95.0	99.2
Number of Crew Members who Require T1 not Scheduled	0	192
Number of Crew Members who Require T3/4 not Scheduled	0	186
Computer Run Time (Seconds)	34	36
Total Number of Required Events Not Scheduled	50	447

Phase VI. In this phase, parameters identical to those of Phase V were used with the exception of the number of TDY days allowed. Sixty of the 71 days of TDY entered as inputs in Phases I through V are permissive TDY days. Permissive TDY days are granted for crew members by their commanders, in support of various activities and only if the schedule allows the loss of the crew member for the number of days requested. Since each commander based their decision to grant the permissive TDY days in March on the assumption that only 13 of the 15 LCFs required crews, it is reasonable to assume that some of the days may not have been granted if all 15 LCFs were operational. All normal TDY days are allowed in this phase; however, all permissive TDY days were eliminated. The inputs for Phase VI are displayed in Table 5.12.

The schedules produced by the new algorithm yielded the results in Table 5.13. Experiment 11 again is designed to use the full capabilities of the new algorithm and schedules alerts, backups, T1s and T3/4s. There were 35 required events left to manually schedule after the new algorithm produced the schedule for Experiment 11. Experiment 12 only schedules alerts. Again, this is accomplished in order to compare the results of the new algorithm with those of the old algorithm. When the new algorithm was used under

the identical conditions that the old algorithm operates under, 925 or 99.5% of the alerts were scheduled.

Table 5.12 Inputs for Phase VI

	Experiment Number	
	11	12
Number of Alerts Required	930	930
Number of Backups Required	62	0
Total Number of Alerts and Backups	992	930
Number of Prescheduled Alerts	40	40
T1s Scheduled	Yes	No
Number of T1 Classes	8	0
T1 Class Size	40	0
T3/4s Scheduled	Yes	No
Number of T3/4 Classes	9	0
T3/4 Class Size	35	0
Number of TDY Days	11	11
Number of X-days	0	0

Table 5.13 Output Results for Phase VI

	Experiment Number	
	11	12
Number of Alerts and Backups Scheduled	957	925
Number of Alerts and Backups Not Scheduled	35	5
Percentage of Alerts and Backups Scheduled	96.5	99.5
Number of Crew Members who Require T1 not Scheduled	0	192
Number of Crew Members who Require T3/4 not Scheduled	0	186
Computer Run Time (Seconds)	35	34
Total Number of Required Events Not Scheduled	35	445

Testing Summary

The results of the even-numbered experiments (Table 5.14) show the new algorithm is superior to the old algorithm for the conditions under which they were tested. Experienced wing schedulers estimate the best possible expected results for scheduling a three-squadron missile wing with the old algorithm is 80%. Under the most demanding scenario, 31 days and 15 LCFs, the new algorithm scheduled 99.2% of the alerts. This was also the worst performance of the new algorithm for any of the experiments designed to validate the algorithm under conditions where the old algorithm operates.

Examining the odd-numbered experiments, the potential gains of using the new algorithm are observed. In Table 5.15 a comparison of the number of events which must be manually scheduled after the schedule is produced is displayed. In the table, the old algorithm is assumed to perform at 85%, this is five percent above its peak estimated efficiency. The difference between the number of events remaining to be scheduled for each algorithm is calculated for each experiment. This number is a direct measure of how much the workload of wing schedulers can be decreased if the new algorithm is adopted.

Table 5.14 Summary of Validation Experiments

Phase	Modification to Inputs	Experiment Number	Percentage of Alerts Covered
I	None	2	100
II	Prescheduled Alerts 40	4	99.9
III	X-days 40	6	99.6
IV	X-days 0	8	100
V	Alerts 930	10	99.2
VI	TDY days 11	12	99.5

Table 5.15 Summary of Comparison of Old and New Algorithm

Phase	Modification to Inputs	Experiment Number	Number of Events Remaining to be Scheduled After Algorithm is Used		Difference Between Old Algorithm and New Algorithm
			Old	New	
I	None	1	508	15	493
II	Prescheduled Alerts 40	3	508	18	490
III	X-days 40	5	508	11	497
IV	X-days 0	7	508	9	499
V	Alerts 930	9	579	50	529
VI	TDY days 11	11	579	35	544

Implementation

The new algorithm has been approved by AFSPACECOM for distribution to missile wings as the prototype for a future automatic scheduling system. F. E. Warren AFB used the algorithm to generate the December 1994 schedule for the Peacekeeper weapon system. The inputs for the schedule contained one missile squadron, one DOV section, one DOT section, 80 crew members, 37 prescheduled alerts, 6 prescheduled backups, 180 days of leave, 510 X-days, 108 e-days, 0 DNIA days, and 6 operational LCFs. The number of X-days was high because the schedulers used an X-day for all required meetings that were prescheduled. There were 9 T1 classes, each with 10 seats, and 4 T3/4 classes, each with 30 seats. Ninety-six percent of the alerts and backups were scheduled, 87% of the crew members who required T1 were scheduled, and 91% of the crew members who required T3/4 were scheduled. The algorithm took five seconds to generate the schedule on the wing schedulers' 486DX33 computer.

Summary

This chapter described the data set used to test the new algorithm and the six phases of testing. The modifications made to the data set at each phase of testing were explained, along with the reasons the changes were made. The statistics generated at each phase were shown and summarized. The results generated by the new algorithm were compared to the results which were estimated to be better than those produced by the old missile crew scheduling algorithm. At each phase of testing the new algorithm, using the same conditions as the old algorithm, out performed the estimated results of the old algorithm. Finally when the new algorithm was installed and used at F. E. Warren AFB the results obtained were superior to those produced by the old algorithm. In the next chapter conclusions are presented along with recommendations concerning improving the new algorithm.

VI. Conclusions and Recommendations

Conclusions

The results generated in Chapter V are only a few data points of a large number of possible ways a missile crew schedule can be built using the new algorithm. The decision matrix can be modified in a number of ways, the scheduled T1 and T3/4 days can be varied with the approval of the instructors, and the leniency of allowable inputs can also be varied. The way crew member inputs are arranged can vary depending on academic schedules, required meetings, leave and TDY. It is impossible to generate schedules using every possible configuration of the inputs to the new algorithm. However, this lack of ability to enumerate all possible test cases does not invalidate the conclusion that the new algorithm generates "better" schedules as measured by the metric described within this research.

The number of events remaining to be manually scheduled after the new algorithm was used to its fullest potential, the odd-experiments, were dramatically reduced when compared to the estimated results for the old algorithm. Each event left to be manually scheduled requires the attention of wing schedulers. There was no case where MCSIS, performing five percent above its estimated highest-rated capacity, came even close to the results produced by the new algorithm. The new algorithm was demonstrated at an AFSPACECOM meeting with representation from each operational missile wing. After the demonstration, the unanimous opinion from seasoned wing schedulers was to implement the new algorithm as soon as possible.

Primary Objective

The primary objective of this research was to develop a heuristic which can quickly produce feasible, or near-feasible, schedules for a missile wing using only the software and

hardware at the disposal of the wing and squadron schedulers. The ability to generate feasible and near-feasible schedules was demonstrated in Chapter V. Also, the flexibility to modify the inputs slightly and generate new schedules was shown. Each experiment in Chapter V required approximately 40 minutes and was measured from the start of editing the inputs to the completion of gathering the statistics. The run time on the computer was never more than forty seconds.

Secondary Objectives

A secondary objective was to move the scheduling process into a paperless environment and provide measures which can be used by the wing schedulers to choose between multiple schedules. This was also accomplished, and the measures of effectiveness are not limited only to the ones generated within the new algorithm. If new measures are deemed important, the crew members' schedules are on spreadsheets, so the new measures can be easily computed for a multitude of other possible objectives.

A survey of over 200 crew members yielded a number of potential measures of effectiveness. Some of these are calculated and displayed by the new algorithm, and others were supported through the logic of the algorithm. Once the schedulers choose a schedule, it can be manipulated to manually schedule any required events and then the final schedule can be distributed electronically.

Recommendations

The most important recommendation is to link this new algorithm with another spreadsheet-based system developed by Captain Rey Canton and Lieutenant C. Shane Clark. Their program provides error checking for the day-to-day manipulations of the schedule and it generates all the reports and statistics required by outside agencies. The combination of the two programs would provide wing and squadron schedulers with a

complete scheduling system. The proposed system will be able to accomplish all the functions currently done by MCSIS and have a more efficient schedule building algorithm using existing hardware and software. The wing schedulers at F. E. Warren AFB have seen both products and have estimated that the number of hours saved at each missile wing to be well over 2,000 hours per year. The combined system would produce a better schedule and free schedulers to improve the scheduling process.

A possible improvement to the algorithm may result if, instead of a strictly greedy algorithm, the day an alert is chosen for a crew member is done with a slightly more farsighted rule. Currently, the day with the largest number of remaining alert actions required for scheduling is chosen. The algorithm may possibly be improved if it looks for the day with the largest difference between number of alerts required and number of crew members still available to perform alert on that day.

Another improvement to the algorithm would be to code the new algorithm in something other than FORTRAN. The only reasons FORTRAN was selected originally were its availability and inexpensive compiler cost. If wings are allowed to change the algorithm each wing would have to purchase a compiler. Since FORTRAN is very restrictive in the way it reads text data, conversions of the data are required within the spreadsheet. Changing to a more flexible language will eliminate the need for these conversions and reduce the time required to produce a monthly schedule.

This was a very inexpensive way to solve a very complex crew scheduling problem. The same logic described in this research may be applicable to space and flying operations. It can also be applied to shift schedules throughout the support community with very little modification required.

APPENDIX A. Crew Survey Questionnaire

SCHEDULING QUESTIONNAIRE

This anonymous questionnaire on scheduling concerns is for an Embry-Riddle graduate research project. The results will also be used in an AFIT thesis being prepared by Captain Mike Shirley and may have an impact on future scheduling policies. Thank you for your time in answering this questionnaire.

1. What is your current rank? (Circle One)

2Lt 1Lt Capt

2. What squadron/division are you assigned to? (Circle One)

10th 12th 490th 564th OSS DOV

3. What is your current functional position? (Circle One)

Line DMCCC Line MCCC TEF DMCCC TEF MCCC
Flight Lead DMCCC Flight Lead MCCC DOT DMCCC
DOT MCCC DOT Section Chief DOT dual qualified
DOV MCCC DOV dual qualified Ops Flight CC

4. How long have you been combat ready? (Circle One)

under 1 yr 1-2 yrs 2-3 yrs 3-4 yrs
over 4 yrs

5. Are you married? (Circle One)

Yes No

6. Do you have any children? (Circle One)

Yes No

7. Are you currently enrolled in a second Bachelors or Masters degree program? (Circle One)

Yes No

8. In the last six months, how many schedule changes have you had? (Circle One)

0-1 2-5 6 or more

9. How many of those changes took place in the last 30 days?

Assuming all alerts, T1, T3, and T4 are covered for the month, how would you weigh the following eight scheduling objectives for measuring how important each one is to you in meeting your professional/personal needs. Please ensure your weights add up to 100. You can have any combination of numbers (e.g. 20 + 20 + 5 + 10 + 0 + 30 + 5 + 10), (90 + 10 + 0 + 0 + 0 + 0 + 0 + 0).

- _____ Maximize integral alert rate.
- _____ Maximize alerts within assigned squadron.
- _____ Minimize difference of work distribution between like crewmembers (i.e. a line MCCC from the 10th and a line MCCC from the 12th).
- _____ Minimize the number of X-days canceled.
- _____ Minimize the number of E-Days canceled.
- _____ Minimize the number of leave days canceled.
- _____ Maximize the number of crewmembers with at least 1 trainer ride a month.
- _____ Maximize the number of SCP crews with at least 1 SCP alert per month.
- _____ Total

11. Looking at your highest weighted objective, please explain why this objective was most important to you.

12. Additional Comments:

APPENDIX B. Stastical Tests Concerning Survey Results

Capt Kent Dalton conducted a survey of two-hundred fourteen missile crew members at Malmstrom Air Force Base in 1994. Background information for each crew member was gathered along with their weights for eight potential scheduling objectives. A copy of the survey is displayed in Appendix A. Assuming all alerts, T1, T3 and T4 requirements are met, crew members were asked to weigh the eight potential measures by distributing one hundred points among the objectives.

The mean for the weights given to each objective were calculated. Each response is assumed to be independent and identically distributed. The expected value of the weight for each objective is the same, 12.5, and the variance for each objective is some value less than infinity. With the sample size much greater than thirty, the Central Limit Theorem was used to test the statistical significance of the mean weight of each objective (Mendenhall and others, 1990:319).

Eight separate one tailed t-tests were conducted. The null hypothesis for each test was the mean for the weight of the objective being tested is less than or equal to 12.5. The alternate hypothesis in each test was the mean weight of the objective being tested is greater than 12.5. An alpha of 0.01, which means the probability of rejecting the null hypothesis when it is true is one percent, was used. Under these conditions only the objectives involving leave and e-days were statistically significant.

APPENDIX C. User's Guide

This user's guide is intended to be a stand alone document and is organized accordingly.

Table of Contents

User Manual Instructions	2
System Requirements.....	2
Installation.....	2
Examples	3
The Big Picture.....	4
Entering Alert Information.....	5
Entering Crew Member Information.....	7
General Guidance, Working with Spreadsheets	18
Rules for Inputting Data into Crew Schedule.....	19
Running AFITSCH.....	25
OUTPUT from AFITSCH	26
Upgrading Crews.....	27
Major Modifications to LCCs.....	27
Problems.....	27

User Manual Instructions

This is a guide to help the user work with the scheduling templates and AFITSCH. AFITSCH is the name of the automatic scheduling program. This guide assumes the user is familiar with Microsoft *EXCEL* 5.0, and DOS and has access to help files and documentation for both programs. No computer programming experience is required to use this system. Keep an electronic copy of this document on the computer which will be used for the automatic scheduler.

System Requirements

To use AFITSCH the minimum system requirements are:

1. A 486DX33 computer
2. 10 Megabytes of hard disk space
3. Microsoft *EXCEL* 5.0
4. Windows 3.1
5. DOS 5.0
6. If a local area network is not in place, a compression program is required to pass large spreadsheets between the wing scheduling office and squadron schedulers.

Installation

To install the system:

1. Create a directory on the hard drive and name it AUTOSCH
2. Copy all the files from each disk into this directory

Examples

There are two types of spreadsheets which are manipulated. The first type of spreadsheet is manipulated by the wing schedulers. This spreadsheet contains information concerning when alerts are required for each day during a given month and other information about the alert or backup. An example of this type of spreadsheet is contained in the *EXCEL* workbook, EXAMPLE.XLS. The name of the spreadsheet within the workbook is Alerts. Details of the use of this type of spreadsheet can be found under ENTERING ALERT INFORMATION. The second type of spreadsheet contains information about crew members. An example of this type of a spreadsheet can also be found in the workbook EXAMPLE.XLS. The name of the spreadsheet within the workbook is Monthly Schedule. More information concerning manipulating this spreadsheet can be found under ENTERING CREW MEMBER INFORMATION.

The Big Picture

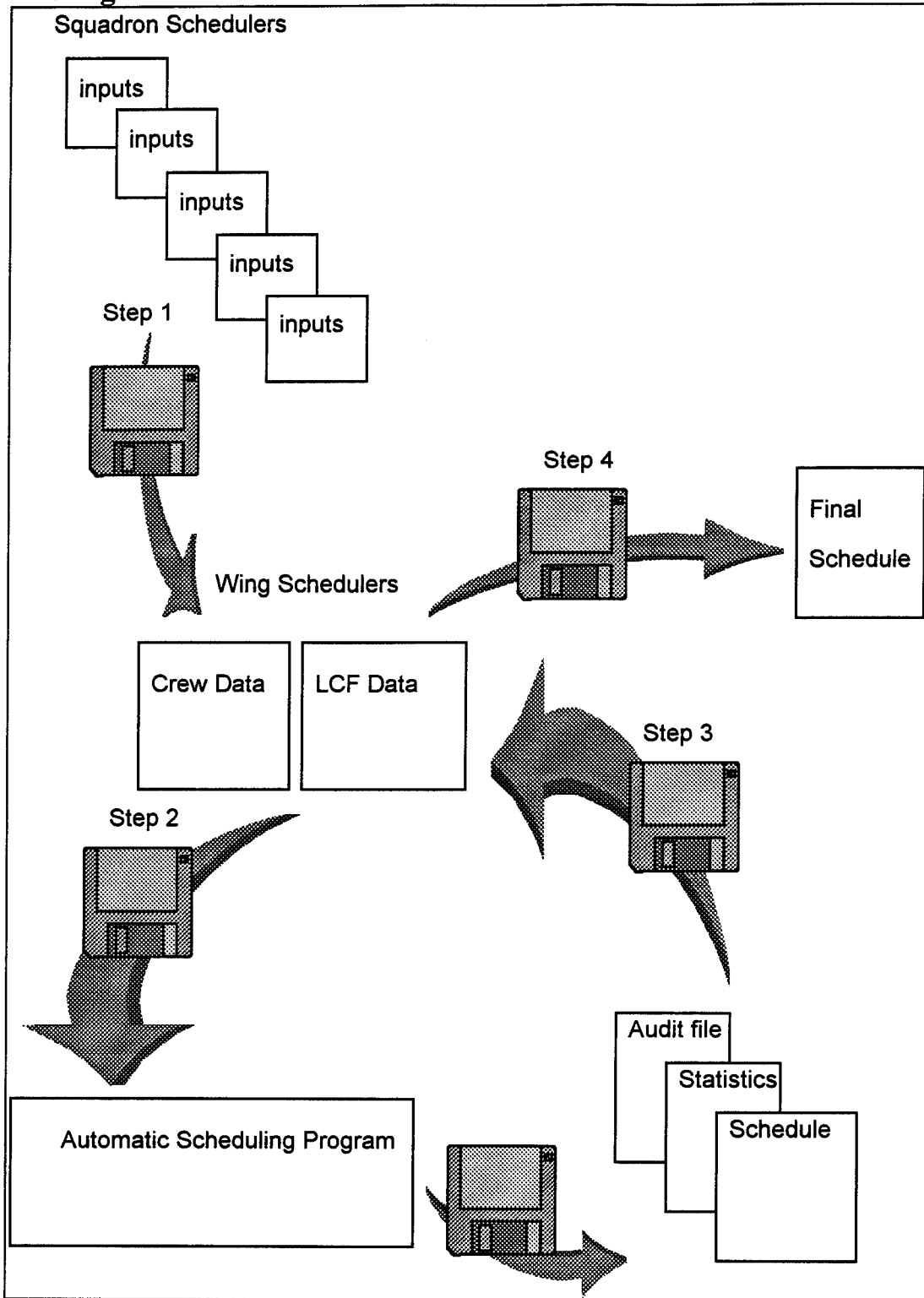

The diagram on the previous page is an overview of the process. Squadron schedulers enter information concerning their crew members on spreadsheets provided by wing schedulers. Wing schedulers synthesize these inputs into one large file and enter the information required for the alerts. These spreadsheets are then formatted so the automatic scheduler can read them. The automatic scheduling program is then run, and it will schedule T1s, T3/4s, alerts and backups, or any subset of these items as directed by the user. The wing schedulers can then manipulate the schedule which is produced by the automatic scheduler and produce a final schedule. Currently, the final schedule will have to be typed into MCSIS or the Black Pirate Software. However, when the link between Black Pirate and AFITSCH is complete, it will not have to be reentered.

Entering Alert Information

When a new monthly schedule is going to be produced, copy the workbook that has the appropriate number of days in it. The workbooks are in the AUTOSCH directory and they are named DAYS28.xls, DAYS29.xls, DAYS30.xls and DAYS31.xls. Within each workbook there is an instruction spreadsheet which contains handy reminders, an alert spreadsheet, a crew member spreadsheet, and spreadsheets which contain functions the workbook needs. The spreadsheets which contain the functions should not be modified (see the *EXCEL* help file to lock these files).

Figure 1 is an example of columns 2 through 10 of the Alerts spreadsheet. **It is best to keep weapon systems completely separate, although the program will work if all weapon systems are entered in one workbook. Do not enter the number of sites in column 1.** This will be calculated by the spreadsheet. This number includes backups as a site.

Round Trip Miles	Drive Time (Hours)	Rank within Squadron	Rank within Wing	SCP	Weapon System	Additional Crew Qualification Required	LCC Alert Name	SQUADRON
		1 is shortest drive time	1 is shortest drive time	SCP	MIII	REACT		10 MIS
					PK	STARWAR		12 MIS
					CDB			490 MIS
30	.55	1	1	SCP	MIII		Aa	10 MIS
30	.55	1	1	SCP	MIII		Aa	10 MIS

Figure 1 Alert Information

Below are instructions for each column 2 through 10.

Column 2, enter the official number of miles to the LCC.

Column 3, enter the official drive time, in hours, to the LCC.

Column 4, enter the Rank, for drive time within the squadron, 1, 2, 3, 4, or 5.

Column 5, enter the Rank, for drive time within the wing, 1-15, or 1-20.

Column 6, if the site is an SCP, enter SCP, if not do not enter anything.

Column 7, enter the weapon system for the site.

Column 8, if a special qualification is required enter it here.

Column 9, enter the Alert Name here, for example Aa or Ab.

Column 10, enter the Squadron the site is in, leave backups blank.

Figure 2 displays how wing schedulers enter the number of alerts required at a given site on a given day. There is a row for the number of commanders required and a row for the number of deputies required. If the site is shutdown and needs no crew members, then enter a 0. If the site is up and needs one crew, enter a 1 on the commander's row and a 1 on the deputy's row. If you need to schedule 2 crews for an alert for any reason, enter a 2 for the commander and a 2 for the deputy.

		1	2	3	4	5
		S	M	T	W	R
		1-May	2-May	3-May	4-May	5-May
Aa	10 MIS	0	0	0	1	1
Aa	10 MIS	0	0	0	1	1
Ab	10 MIS	1	1	1	1	1
Ab	10 MIS	1	1	1	1	1

Figure 2 Days Alerts are Required

Entering Crew Member Information The crew member information will be entered in the same workbook as the one used when the alerts were entered. The wing schedulers will enter the information for the Alerts spreadsheet within the workbook and then enter some of the information for the crew members spreadsheet. Then copies of the workbook are distributed to each squadron/division scheduler. The squadron and division schedulers enter information concerning their crew members and return the copy to wing scheduling.

Much of the information in rows 1 through 51 will not change from month to month, and copy and paste functions can be used to speed the process of entering this

data. However, **be extremely careful when copying and pasting information from spreadsheets which are used for months containing different numbers of days.**

Before entering information on the crew members schedule spreadsheet, turn the calculation to manual. This will prevent the spreadsheet from calculating after every entry. To stop the spreadsheet from calculating if it has begun and you do not want it to continue, press the ESC key.

The spreadsheets that arrived with the program only contain formatted rows for thirty crew members. When more than this number is required, for example a full missile squadron, copy and past the number of entries needed. Each crew member is allotted twelve rows. **Do not paste anything below row 3000 on any spreadsheet. This is due to a limitation on the number of crew members AFITSCH can currently handle, 224 crew members.**

Figure 3 displays the first nine rows of the Schedule spreadsheet. The first row and the first column tells the user where they are in the spreadsheet, and they can be used to resort the spreadsheet if the spreadsheet is sorted incorrectly, and the spreadsheet has not been calculated since the sort. The second row contains the titles for each column. The second column has the job titles for each crew member. These entries should not be changed, and must be typed in exactly as shown when used in other parts of the spreadsheet. The rest of the figure contains the distribution of alerts for each type of crew member. The user can change any of the entries within this section of the spreadsheet. AFITSCH will try to cover all the alerts by assigning the alert levels according to the beginning column. However, if all the alerts cannot be covered at these levels, it moves to the next column and uses these numbers as the maximum number of alert actions for this type of crew member. When looking at alert actions, AFITSCH takes leave and TDY into account, except for the Beginning Alert load for DOT and DOV crews. The first alert levels for DOV and DOT are done without consideration of leave or TDY. When

entering these numbers, they should agree with local guidelines for additional alerts. Also, the numbers should not decrease reading from left to right. **The Total row is calculated by the spreadsheet and should not be entered.**

1	2	3	4	5	6	7	8	9	10	11	12	13	14	15	16	17
2	Job	Beginning Alert Load		Distribution of Additional Alerts												
3	DOT	2	2	2	2	3	4	4	4	5	5	6	6	6	7	8
4	DOV	2	2	2	2	3	4	4	4	5	5	6	6	6	7	8
5	FL	5	6	6	7	8	8	8	8	8	8	8	8	8	8	8
6	LINE	6	7	8	8	8	8	8	8	8	9	9	9	9	9	9
7	OPSFL	2	2	2	2	2	2	3	4	4	4	4	5	6	7	8
8	TEF	2	2	2	2	3	4	4	4	5	5	6	6	6	7	8
9	Total	19	21	22	23	27	30	31	32	35	36	39	40	41	45	49

Figure 3 Alert Distribution Matrix

Starting in row 11 (see Figure 4), the rules that the spreadsheet uses to determine if a crew member is available for an alert, for a given day, are created. Each row contains events that crew members are allowed to, or not allowed to, accomplish in a given time frame. For example, in row number 11 of Figure 4, the events a crew member cannot do two days prior to an alert or backup are listed. These entries must be entered exactly as they appear on the schedule. The only exception is B, which represents a Backup instead of B1 or B2. Once these entries are setup for a given weapon system they will not require changes, unless a new event is allowed, or not allowed, for a given time frame. If only site names are to be changed, the procedure is easy. Type the sites for your weapon system over the sites on the template. **However, if the number of entries in a row is changed.**

The name which refers to that block of events must be redefined. This is not difficult but it must be done for the scheduling rules to be accomplished correctly.

The name of each block of events is contained in parenthesis in column two of the row. To change the block which the name refers to, select Insert on the toolbar, select define, select the name from the list of names, then on the spreadsheet, select the area which will be the newly defined block and press ENTER.

Row 13 contains the start times of MPTs that will not allow crew members to pull alerts the next day. These numbers can be changed to reflect the duration of the longest MPT. If the longest MPT at a given wing is four hours, then to meet the requirement for no training past 1900, the numbers 15, 16, 17, 18, 19, and 20 should be entered. The spreadsheet looks at elements two and three of each event to see if they contain one of these numbers. If an MPT is scheduled for one of these times, an alert or backup cannot be scheduled the following day. All trainer rides should be of the form ?##*, where the question mark is an alphabetic character, the two number signs are the start time of the MPT in hours (24 hour clock), and the * is any additional coding required to tell crew members what type of MPT they will receive.

11	Cannot Do 2 Days Prior to Alert or B, (twodayp)	B	Aa	Ab	Ac	Ad	Ae	Af	Ag	Ah	Ai	Aj	Ak	Al	Am	An	Ao		
12	Cannot Do 1 Day Prior to Alert or B, (onedayp)	L	O	B	Aa	Ab	Ac	Ad	Ae	Af	Ag	Ah	Ai	Aj	Ak	Al	Am	An	Ao
13	Late Rides Day Before Alert or B, (latetrainers)	16	17	18	19	20													
14	Can Do Day of Alert or B																		
15	Can Do 1 Day After Alert or B, (canlداfter)	E																	
16	Cannot Do 2 Days After Alert or B, (twodaya)	B	Aa	Ab	Ac	Ad	Ae	Af	Ag	Ah	Ai	Aj	Ak	Al	Am	An	Ao		

Figure 4 Schedule Rule Blocks

In row 17 (see Figure 5) the alert names of each SCP need to be entered. If the number of SCPs is not three, the same procedure to change the block name as described

for the event blocks is required. **The number of SCPs is calculated by the spreadsheet and should not be entered.**

17	SCP ALERTS	Aa	Ag	Ak
18				
19		NUMBER OF SCPS	3	

Figure 5 SCP Information

Rows 21 through 41 contain information which is used to standardize the inputs for each crew member entered on the spreadsheet. An example is displayed in Figure 6. The second column contains a Y or N. A Y tells AFITSCH the crew member's schedule is to be built, and a N means don't schedule the crew member. An example of when an N might be used is a crew member that is not combat ready. If an N is used, the crew member will have to be manually scheduled for T1 and T3/4 if they require the training.

The rest of the columns in Figure 6 contain attributes for the crew member. The third column is the crew member's MCHN number. The fourth is the organization, and this must be formatted exactly as it is displayed on the Alerts spreadsheet. The flights in column 5 must be capital letters, and the TEFs must have their squadron's numbers followed by the letters TEF, with no spaces between the numbers and the letters TEF. Columns 6 and 7 contain the prefix for the crew number and the crew number. In column 8 the crew position is entered, C, D or B. **If a B is entered, AFITSCH will look at it as D, and only schedule deputy alerts. It is recommended to use only C or D.** The next four columns contain the crew member's name, and the last column indicates whether a crew member is SCP qualified or not.

21	AUTO	MHCN	Organiza tion	Flight	Prefix	Crew #	Crew Position	Rank	First	Last	Middle	JR/ SR/ III	SCP Qual
22	Y		OSS	A	N		C	2LT				JR	Y
23	N		OG	B	R		D	1LT				SR	N
24			10 MIS	C	E		B	CAPT				II	
25			12 MIS	D	S			MAJ				III	
26			490 MIS	E				LTCOL				IV	
27				F				COL				V	
28				G									
29				H									
30				I									
31				J									
32				K									
33				L									
34				M									
35				N									
36				O									
37				10TEF									
38				12TEF									
39				490TEF									
40				DOT									
41				DOV									

Figure 6 Crew Member Individual Information

An example of entries in the first fourteen columns of rows 42 through 55 is displayed in Figure 7. **Row 42 contains the number of days in the current month. This is generated by the spreadsheet and should not be entered.** Rows 44 and 45 show which days T1 and T3/4 are scheduled. The actual days they are scheduled are marked by a T1 and/or T3/4 directly over the day. These columns will be displayed later. In row 50, the number of crew members on the spreadsheet is calculated. To find the next MHCN, the spreadsheet finds the largest MHCN number on the spreadsheet, and then adds one to it. This is not the way MCSIS generates MHCNs. So if you are using MCSIS, let MCSIS pick the MHCN number. The same column titles as those displayed earlier in row 51. Starting in row 52, crew member information is entered. Each crew member is allotted 12 rows. When entering personal data for a crew member (see Figure 7), only the first row of information is entered. In the example this is row 52. The spreadsheet will copy the information from the first row of the crew member data into the remaining 11 rows.

42												31	Days in month
43													
44										Dates Monthly			T3/4
45										Training Offered			T1
46													
47													
48													
49	# of Entries	Next MHCN is											
50	4	159											
51	AUTO	MHCN	Org	Flight	Prefix	Crew #	Crew Position	Rank	First	Last	Mid dle	JR/ SR/ III	SCP Qual
52	Y	48	10 MIS	C	R	24	D	2LT	GERALD	MCGHEE	P.		N
53	Y	48	10 MIS	C	R	24	D	2LT	GERALD	MCGHEE	P.		N
54	Y	48	10 MIS	C	R	24	D	2LT	GERALD	MCGHEE	P.		N
55	Y	48	10 MIS	C	R	24	D	2LT	GERALD	MCGHEE	P.		N

Figure 7 Example Crew Member Attributes

The information in the columns which are to the right of those in Figure 7 is displayed in Figure 8. **Wing schedulers will enter T3/4 and T1 above the days they are offered.** The next few rows contain the day of the month, the day of the week numerically, the day of the week represented by letters, and the date. **When a new month is being created, enter the date 2 days prior to the first of the month which is being created, then copy and drag to the right to change the dates for the rest of the date cells.** The first three rows are for entering the crew member's schedule of events. Notice in Figure 8 the two days prior to the effective month are entered. These days are needed so AFITSCH can deconflict the current month with the previous month. The first two days of the month following the effective month are also represented. This is so AFITSCH can deconflict with leave and other events in the month following the effective month.

44	Dates Monthly			T3/4			T3/4			
45	Training Offered			T1						
46					27	28	1	2	3	4
47					3	4	5	6	7	1
48					T	W	R	F	SA	S
49					27-Feb	28-Feb	1-Mar	2-Mar	3-Mar	4-Mar
50										
51	Last	Middle	JR/SR/III	SCP QUAL						
52	MCGHEE	P.		N		Ac	O			
53	MCGHEE	P.		N						
54	MCGHEE	P.		N						
55	MCGHEE	P.		N			0	1	0	0
56	MCGHEE	P.		N			1	1	0	0
57	MCGHEE	P.		N			0	0	0	0
58	MCGHEE	P.		N			1	0	0	0
59	MCGHEE	P.		N			0	0	0	0
60	MCGHEE	P.		N			0	0	0	0
61	MCGHEE	P.		N			0	0	1	1
62	MCGHEE	P.		N			0	0	1	0
63	MCGHEE	P.		N			0	0	0	0

Figure 8 First Days of Crew Schedule and T1, T3/4 Days

The guidance for working with the templates and specific rules for entering information follows.

General Guidance, Working with Spread Sheets

- 1. Make a copy of the original workbooks and store them in a safe place.**
- 2. Do not delete or add any rows or columns.**
3. The spreadsheets are not automatic schedulers, they are used to prepare the inputs for the automatic scheduler.
- 4. Currently these sheets are not protected, so see Help to Lock cells you do not want other people to change.**
- 5. Turn the calculation to manual** to prevent the spreadsheets from calculating after each input. To do this select on Tools, drag down to Options, open the Calculation Tab, and set to Manual.
6. When using these templates to pass inputs to and from each squadron, only give the squadrons their file.
- 7. To calculate only the sheet you're working on**, with calculation set to Manual, press **SHIFT and F9**. To Calculate the entire workbook press **F9**.
- 8. If you don't want to see all the zeros**, select **Tools and drag to Options**, then under **View**, select **off view zeros**.
9. When **iT1 or T1** is entered, the spreadsheet counts either as a ***T1**.
- 10. The first column and first row should never be changed. They count the number of cells used and if the spreadsheet gets sorted oddly, they can be used to rebuild it to its original state.**

Rules for Inputting Data into Crew Schedule

1. If a crew member is scheduled for any of the following events, they **must be entered in the first row** of the crew member's schedule: **Leave, Backup, Alerts, O days, T3/4, T1, iT1, TDY, and PTDY.**
2. **If none of the above items are scheduled for that day, anything except E can be put in the first row.**
3. **If someone is scheduled for an E, then it must be entered in the third row. This is not true for EDAY.**
4. **Do not insert Blanks** before or after events.
5. **Use all caps unless you're entering an alert.** Then input Aa.
6. **Use an O, not an o, or 0, for an O day.**

In row 44 and 45 of Figure 9, the spreadsheet calculates the total number of T1s and T3/4s. **This is also where the wing schedulers enter the class size limits for each class. If there is more than one weapon system at the wing and their schedules are being generated by two different spreadsheets, divide the seats by the percentage of crew members in each weapon system. For example, if the wing has PK and MIII units and they are being scheduled separately, and there are 50 PK crew members and 100 MIII crew members, 1/3 of the total class seats should be used for the PK class size limit and 2/3 for MIII. If both weapon systems are using the same spreadsheet, this is not required. There is currently a 240 crew member limit for AFITSCH, so a four squadron wing may have to be broken up by weapon system.**

43								Total times offered	Class Size Limit
44		T3/4						8	30
45		T1		T1				8	35
46		28	29	30	31	1	2		
47		4	5	6	7	1	2		Total number of Zeroes
48		W	R	F	SA	S	M		0
49		28-Mar	29-Mar	30-Mar	31-Mar	1-Apr	2-Apr		
50								Number of Days	
51								Available for Alert	Alert and Training Conflicts
52									# of Zeroes
53									0
54									
55		0	0	0	0				Two days Prior to Alert
56		0	0	0	0				One Day Prior to Alert
57		0	0	0	0				Late Night Trainer
58		0	0	0	0				Day of Alert
59		0	0	0	0				One Day After Alert
60		0	0	0	0				Two days After
61		1	1	1	1			21	Available for Alert or B
62		0	0	1	0			8	First Possible
63		0	0	0	0				LEAVE

Figure 9 Last Few Days of Crew Member Schedule

As mentioned previously, the first two days of the month after the month being scheduled is displayed on the spreadsheet. This prevents conflicts with events scheduled

C-20

at the beginning of the next month. The numbers of zeros in row 52 refers to the total number of zeros entered in the first row of a crew member's schedule. This finds errors that were made by entering a 0 instead of an O when entering O days. Rows 55 through 60 of Figure 9, which contain zeros and ones, are the rows used to determine if a given day is viable for an alert or backup. If there is no conflict, the spreadsheet enters a zero for that row on that day. If there is a conflict, the spreadsheet enters a one for that row on that day. If there are zeros for rows 55 through 60 for a given day, then a crew member is available for alert that day. This is denoted by a 1 in column 61. This is done for each crew member entered on the spreadsheet.

The total number of days which are viable for a crew member to be chosen for alert is displayed next to Available for Alert or B. This row is purple on the spreadsheet so it can be easily found in case a crew member needs to be located for a manual fix to the schedule. If a crew member is scheduled for an alert on the first available day, then the total number of alerts they can be scheduled for is computed and displayed next to First Possible. The leave row shows which days a crew member is on leave.

The totals in the third row of Figure 10 include data for all the crew members on the spreadsheet. The totals for the individual crew member are in row seven. If someone does not have T1 or T3/4 scheduled, or they have more than one of either scheduled, a warning message is displayed for that crew member. Pseudo alerts take leave and TDY into account when coming up with the total number of normal and pseudo alerts.

TOTAL	TOTAL	TOTAL			TOTAL	TOTAL	TOTAL	TOTAL	TOTAL		TOTAL	TOTAL
HARD	BACKUPS	ACTIONS			LEAVE	TDY	X	E	DNIA		NO T1s	NO T3/4s
0	0	0			12	0	0	4	0		3	3
				Total								
Hard	B	Alert	Pseudo	Normal and	L	TDY	X	E	DNIA	SCP	# of	# of
Alerts	Backups	Actions	Alerts	Pseudo	Leave	days	X days	E days	days	alerts	*T1s	T3/4s
0	0	0	0	0	0	0	0	0	4	0	0	0
											No T1	No T3/4

Figure 10 Schedule Statistics

Figure 11 has more information concerning each crew member. The first item is a calculation which is done by the spreadsheet. The spreadsheet looks at the job title in the next column, goes to the alert distribution matrix and finds the number of alerts a crew member with this title is scheduled for on the first pass of AFITSCH. The spreadsheet then subtracts this number for the total number of days the crew member is available for alert. This is a measure of how restrictive the crew member's schedule is. The next column contains the weapon system the crew member is qualified in. This must match the weapon systems used for the Alert spreadsheet. The Special Qualification is left blank unless the crew member has a special qualification which matches the Additional Qualification required in the Alert spreadsheet. The Education program is a way to track the number of crew members in each education program. If a crew member is not in a program enter a N.

Days available				
- normal Alert load	Job	Weapon System	Special Qualification	Education Program
14	LINE	MIII		N

Figure 11 Crew Member Information

Figure 12 contains more information pertaining to the crew member. This information can be entered by the wing or squadron schedulers.

Social Security Number	Initial EWO Cert Date	Last Cert Date	Missile Safety Date	Nuclear Surety Date	BIO PAK Date	Physical Expires	Gender	ROW
500-12-5005	23-Feb-90	23-Apr-90	23-Apr-90	23-Apr-90	23-Apr-90	18-Apr-91	M	1

Figure 12 Crew Member Historical Data

Preparing Spreadsheets for AFITSCH

Once all the units have returned their inputs to wing scheduling, the wing schedulers can begin building a schedule. Copy the rows below row 51, which contain crew member information, for each squadron into one workbook. The workbook will be the same one that was used to generate the Alerts spreadsheet. When this is complete, one workbook should have the Alerts, Monthly Schedule, Instruction, and Functions spreadsheets.

In order for AFITSCH to work efficiently, the Alerts and Monthly Schedule spreadsheets must be prepared properly. First prepare the Alerts spreadsheet. This is done by opening it and pressing the SHIFT and F9 keys at the same time to calculate the sheet. Hide the zeroes by selecting Tools, Options, View and then turn off view zeroes.

The next thing that needs to be done is to reformat the text on the worksheet by putting quotes around all the text on the spreadsheet. First, select the entire worksheet, then select Format on the toolbar, select Text, select Customize and enter '@'. Click okay through any warning messages and when it's complete, all the text will have single quotes around it. **Do not edit the spreadsheet in anyway after it's reformatted with quotes. If something needs to be changed, format the spreadsheet using the general option and make the changes.** Now the file has to be saved as comma delimited and given a specific name. Select File, select Save As, enter ALERTS.CSV as the file name, and select the AUTOSCH directory on the hard drive. AFITSCH cannot access the file if it is currently open, so make sure it's closed prior to running AFITSCH. Also, reformat the spreadsheet to its original form by selecting ALL and General using the same format steps as described above. When the workbook is saved, it needs to be saved in its original form which means choose Save As, enter any file name you care to, and the type of file should be XLS. When you save a file as XLS, the entire workbook is saved.

To prepare the Monthly Schedule spreadsheet, a few additional steps need to be addressed. First, check the entries for each crew so no numbers are entered by themselves under the days of crew members' schedules. An entry of 245 will make AFITSCH crash, however, 245a will not. Also make sure all the input rules were followed. Once that is complete press the SHIFT and F9 keys at the same time. This will calculate the spreadsheet. Once it's complete check to make sure no zeros were entered instead of Os for O days.

For AFITSCH to work efficiently, the crew members must be sorted from those with the most restrictive schedule to those with the most flexible schedule. This is done by selecting all the rows from 52 down which contain crew member information. Then select sort, sort on the Alerts Available minus Alerts required column (BM) in ascending order, and the SCP qualification column(N), in ascending order. The first sort ensures the

most restrictive schedules are handled first, and the second ensures crew members who have less flexible qualifications are scheduled next. The SCP qualification is a way of breaking ties if crew members have the same value for column BM.

Hide the zeroes if they are showing. The next thing that needs to be done is to reformat the text on the worksheet by putting quotes around all the text on the spreadsheet. First, select the entire worksheet, then select on Format on the toolbar, select Text, select Customize and enter '@'. Press OK through any warning messages and when it's complete, all the text will have single quotes around it. **Do not edit the spreadsheet in anyway after it's reformatted with quotes. If something needs to be changed, format the spreadsheet using the general option and make the changes.** Now the file has to be saved as comma delimited and given a specific name. Select File, select Save As, enter MEMBERS.CSV as the file name, and select the AUTOSCH directory on the hard drive. AFITSCH cannot access the file if it's currently open, so make sure it's closed prior to running AFITSCH. Also reformat the spreadsheet to its original form by selecting ALL and General using the same format steps as described above. When the workbook is saved, it needs to be saved in its original form which means choose Save As, enter any file name you care to, and the type of file should be XLS. When you save a file as XLS, the entire workbook is saved.

The files ALERT.CSV and MEMBERS.CSV are the only two inputs to AFITSCH. They must be formatted correctly and stored in the AUTOSCH directory for the program to work properly.

Running AFITSCH

Make sure the input files, ALERT.CSV and MEMBERS.CSV, are closed and in the AUTOSCH directory. Then check to see that AFITSCH.EXE is in the AUTOSCH directory. At least 5 megabytes of hard drive space must be available to run the program. At the DOS prompt, change directories to the AUTOSCH directory. Type AFITSCH and

press ENTER. A few lines of text will be presented. Enter a 1 for each item you would like to have scheduled. If you would like T1s, T3/4s and Alerts and Backups scheduled, enter three 1s. The program will be complete when the DOS prompt appears again.

OUTPUT from AFITSCH

There are three files created by AFITSCH: TRACER.TXT, STATS.CSV, and CREWSCH.CSV. TRACER.TXT is a large text file that follows the flow of the program. The only use it has is if the program crashes. If AFITSCH does crash, open TRACER in any text editor and find the last item it read correctly. Most AFITSCH crashes are due to input errors, so look at the information entered directly after the information printed at the end of TRACER. If the program ran correctly delete TRACER.

The file STATS.CSV is a comma delimited file containing information concerning which alerts were not covered. This file will not be created unless Alerts and Backups were chosen to be scheduled. The best way to read this file is to read it into *EXCEL*.

CREWSCH.CSV is also a comma delimited file. It contains the first three lines of each crew member's schedule. It can be best viewed in *EXCEL*. An additional group of files, CONVRT28.XLS through CONVRT31.XLS, can be used to remove the blanks from CREWSCH.CSV file and gather statistics concerning the schedule generated. With CREWSCH.CSV open in *EXCEL*, open CONVRT##.XLS, where ## is the number of days in the scheduled month. Highlight the area which contains the crew member information and select copy, then paste this into CONVRT##.XLS under the appropriate row. Do not copy over any header information. Do not copy the first column with all the Ys and Ns. If items are added to this file, add them under the columns with the blue header. Do not add items under the red TRIMMED header. The information with the blanks removed will be displayed under the red TRIMMED header, along with statistics concerning the schedule. **Until the link between Black Pirate and AFITSCH is created, the new schedule must be typed into either MCSIS or Black Pirate.**

Upgrading Crews

Upgrade crews can be handled one of two ways. The easiest way is to enter an N, in the auto schedule column and schedule their alerts manually. The second way is to enter a Y in the auto schedule column and make sure something is entered on everyday until they certify. Then after the schedule is built remove the false items from their schedules.

Major Modifications to LCCs

If an LCC is undergoing a major modification, for example REACT, AFITSCH can handle it. Create two LCCs with exactly the same entries except for the Additional Qualification column. Enter REACT for one of the LCCs and leave the other blank. Both LCCs will have a commander row and a deputy row. When the site is up and running before the modification, enter 1s for the LCC with the blank Additional Qualification and enter 0s for the REACT LCC. When the site is given to the contractors for the modification, enter 0s for both LCCs. When it returns from the modification, enter 1s for the Additional Qualification LCC and 0s for the blank LCC.

Problems

Most problems occur in AFITSCH due to input errors. Make sure the directions for formatting the input files were followed and all data entry problems are corrected. If error messages such as INVALID STRING or INVALID INTEGER occur, look at the TRACER.TXT file in any editor to see what the last valid data read was and work from there.

APPENDIX E. Statistics Output File

NUMBER OF ALERTS NOT COVERED IS NUMBER OF PASSES REQUIRED COMMANDERS MATRIX	WEAPON SYSTEM	SPECIAL QJAL	SITE	SQUADRON	Days																														
					1	2	3	4	5	6	7	8	9	10	11	12	13	14	15	16	17	18	19	20	21	22	23	24	25	26	27	28	29	30	31
35	MIII		Aa	10 MIS	0	0	0	0	0	0	0	0	0	0	0	0	0	0	0	0	0	0	0	0	0	0	0	0	0	0	0	0	0		
15	MIII		Ab	10 MIS	0	0	0	0	0	0	0	0	0	0	0	0	0	0	0	0	0	0	0	0	0	0	0	0	0	0	0	0	0		
	MIII		Ac	10 MIS	0	0	0	0	0	0	0	0	0	0	0	0	0	0	0	0	0	0	0	0	0	0	0	0	0	0	0	0	0		
	MIII		Ad	10 MIS	0	0	0	0	0	0	0	0	0	0	0	0	0	0	0	0	0	0	0	0	0	0	0	0	0	0	0	0	0		
	MIII		Ae	10 MIS	0	0	0	0	0	0	0	0	0	0	0	0	0	0	0	0	0	0	0	0	0	0	0	0	0	0	0	0	0		
	MIII		Af	12 MIS	0	0	0	0	0	0	0	0	0	0	0	0	0	0	0	0	0	0	0	0	0	0	0	0	0	0	0	0	0		
	MIII		Ah	12 MIS	0	0	0	0	0	0	0	0	0	0	0	0	0	0	0	0	0	0	0	0	0	0	0	0	0	0	0	0	0		
	MIII		Ai	12 MIS	0	0	0	0	0	0	0	0	0	0	0	0	0	0	0	0	0	0	0	0	0	0	0	0	0	0	0	0	0		
	MIII		Aj	12 MIS	0	0	0	0	0	0	0	0	0	0	0	0	0	0	0	0	0	0	0	0	0	0	0	0	0	0	0	0	0		
	MIII		Ak	490 MI	0	0	0	0	0	0	0	0	0	0	0	0	0	0	0	0	0	0	0	0	0	0	0	0	0	0	0	0	0		
	MIII		Al	490 MI	0	0	0	0	0	0	0	0	0	0	0	0	0	0	0	0	0	0	0	0	0	0	0	0	0	0	0	0	0		
	MIII		Am	490 MI	0	0	0	0	0	0	0	0	0	0	0	0	0	0	0	0	0	0	0	0	0	0	0	0	0	0	0	0	0		
	MIII		An	490 MI	0	0	0	0	0	0	0	0	0	0	0	0	0	0	0	0	0	0	0	0	0	0	0	0	0	0	0	0	0		
	MIII		Ao	490 MI	0	0	0	0	0	0	0	0	0	0	0	0	0	0	0	0	0	0	0	0	0	0	0	0	0	0	0	0	0		
	MIII		B		0	0	0	0	0	0	0	0	0	0	0	0	0	0	0	0	0	0	0	0	0	0	0	0	0	0	0	0	0		
					0	0	0	0	0	0	0	0	0	0	0	0	0	0	0	0	0	0	0	0	0	0	0	0	0	0	0	0	0		
ALERTS REQUIRED EACH DAY					0	0	0	0	0	0	0	0	0	0	0	0	0	0	0	0	0	0	0	0	0	0	0	0	0	0	0	0	0		
COMMANDER ALERTS NOT COVERED	8																																		
DEPUTIES MATRIX																																			
	MIII		Aa	10 MIS	0	0	0	0	0	0	0	0	0	0	0	0	0	0	0	0	0	0	0	0	0	0	0	0	0	0	0	0			
	MIII		Ab	10 MIS	1	0	0	0	0	0	0	0	0	0	0	0	0	0	0	0	0	0	0	0	0	0	0	0	0	0	0	0			
	MIII		Ac	10 MIS	0	0	0	0	0	0	0	0	0	0	0	0	0	0	0	0	0	0	0	0	0	0	0	0	0	0	0	0	0		
	MIII		Ad	10 MIS	0	0	0	0	0	0	0	0	0	0	0	0	0	0	0	0	0	0	0	0	0	0	0	0	0	0	0	0	0		
	MIII		Ae	10 MIS	0	0	0	0	0	0	0	0	0	0	0	0	0	0	0	0	0	0	0	0	0	0	0	0	0	0	0	0	0		
	MIII		Af	12 MIS	0	0	0	0	0	0	0	0	0	0	0	0	0	0	0	0	0	0	0	0	0	0	0	0	0	0	0	0	0		
	MIII		Ag	12 MIS	0	0	0	0	0	0	0	0	0	0	0	0	0	0	0	0	0	0	0	0	0	0	0	0	0	0	0	0	0		
	MIII		Ah	12 MIS	0	0	0	0	0	0	0	0	0	0	0	0	0	0	0	0	0	0	0	0	0	0	0	0	0	0	0	0	0		
	MIII		Ai	12 MIS	0	0	0	0	0	0	0	0	0	0	0	0	0	0	0	0	0	0	0	0	0	0	0	0	0	0	0	0	0		
	MIII		Aj	12 MIS	0	0	0	0	0	0	0	0	0	0	0	0	0	0	0	0	0	0	0	0	0	0	0	0	0	0	0	0	0		
	MIII		Ak	490 MI	0	0	0	0	0	0	0	0	0	0	0	0	0	0	0	0	0	0	0	0	0	0	0	0	0	0	0	0	0		
	MIII		Al	490 MI	0	0	0	0	0	0	0	0	0	0	0	0	0	0	0	0	0	0	0	0	0	0	0	0	0	0	0	0	0		
	MIII		Am	490 MI	0	0	0	0	0	0	0	0	0	0	0	0	0	0	0	0	0	0	0	0	0	0	0	0	0	0	0	0	0		
	MIII		An	490 MI	0	0	0	0	0	0	0	0	0	0	0	0	0	0	0	0	0	0	0	0	0	0	0	0	0	0	0	0	0		
	MIII		Ao	490 MI	0	0	0	0	0	0	0	0	0	0	0	0	0	0	0	0	0	0	0	0	0	0	0	0	0	0	0	0	0		
	MIII		B		1	0	0	0	0	0	0	0	0	0	0	0	0	0	0	0	0	0	0	0	0	0	0	0	0	0	0	0	0		
ALERTS REQUIRED EACH DAY					1	0	0	0	0	0	0	0	0	0	0	0	0	0	0	0	0	0	0	0	0	0	0	0	0	0	0	0	0		
DEPUTY ALERTS NOT COVERED	27																																		

APPENDIX F. Crew Schedule File

	1	2	3	4	5	6	7	8	9	10	11	12	13	14	15
	DAY														
Y 158 H	73 C	MISTY	COSSON												
Y 158 H	73 C	MISTY	COSSON												
Y 158 H	73 C	MISTY	COSSON												
Y 124 I	85 C	JOEL	CLOETER												
Y 124 I	85 C	JOEL	CLOETER												
Y 124 I	85 C	JOEL	CLOETER												
Y 48 C	24 D	GERALD	MCGHEE												
Y 48 C	24 D	GERALD	MCGHEE												
Y 48 C	24 D	GERALD	MCGHEE												
Y 121 I	82 C	JOSEPHLEWI	PRUE												
Y 121 I	82 C	JOSEPHLEWI	PRUE												
Y 121 I	82 C	JOSEPHLEWI	PRUE												
Y 80 B	13 C	JOHN	MUIRHEAD												
Y 80 B	13 C	JOHN	MUIRHEAD												
Y 80 B	13 C	JOHN	MUIRHEAD												
Y 197 I	82 D	WILLIAM	LANE												
Y 197 I	82 D	WILLIAM	LANE												
Y 197 I	82 D	WILLIAM	LANE												
Y 75 A	3 C	THOMAS	BROWNING												
Y 75 A	3 C	THOMAS	BROWNING												
Y 75 A	3 C	THOMAS	BROWNING												
Y 73 A	9 C	ROLLINS	HICKMAN												
Y 73 A	9 C	ROLLINS	HICKMAN												
Y 73 A	9 C	ROLLINS	HICKMAN												
Y 54 F	54 C	JOHN	FREEDMAN												
Y 54 F	54 C	JOHN	FREEDMAN												
Y 54 F	54 C	JOHN	FREEDMAN												
Y 40 12TEF	210 C	STEVEN	CREWS												
Y 40 12TEF	210 C	STEVEN	CREWS												
Y 40 12TEF	210 C	STEVEN	CREWS												
Y 222 L	111 C	RICHARD	FORRISTALL												
Y 222 L	111 C	RICHARD	FORRISTALL												
Y 222 L	111 C	RICHARD	FORRISTALL												
Y 131 L	111 D	CHARLES	DAVIS												
Y 131 L	111 D	CHARLES	DAVIS												
Y 131 L	111 D	CHARLES	DAVIS												
Y 64 10TEF	201 D	SAMUEL	BASS												
Y 64 10TEF	201 D	SAMUEL	BASS												
Y 64 10TEF	201 D	SAMUEL	BASS												
Y 262 L	113 D	CHARLES	HICKS												
Y 262 L	113 D	CHARLES	HICKS												
Y 262 L	113 D	CHARLES	HICKS												
Y 39 10TEF	204 C	PATRICK	DUFRAINE												
Y 39 10TEF	204 C	PATRICK	DUFRAINE												
Y 39 10TEF	204 C	PATRICK	DUFRAINE												
Y 30 10TEF	201 C	PAUL	SCHOLL												
Y 30 10TEF	201 C	PAUL	SCHOLL												
Y 30 10TEF	201 C	PAUL	SCHOLL												
Y 226 J	92 C	MICHAEL	EDINGER												
Y 226 J	92 C	MICHAEL	EDINGER												
Y 226 J	92 C	MICHAEL	EDINGER												
Y 154 B	12 C	DAVID	LAKE												
Y 154 B	12 C	DAVID	LAKE												
Y 154 B	12 C	DAVID	LAKE												

Bibliography

- Baker, Bruce N. *Introduction to Sequencing and Scheduling*. New York: John Wiley & Sons, 1974.
- Berg, Capt David H., and Nuss, Capt Rodney G. *An improved Missile Combat Crew Scheduling System Using the Simulation Language for Alternative Modeling (SLAM)*, MS Thesis, AFIT/GST/OS/84M-2. School of Engineering, Air Force Institute of Technology (AU), Wright Patterson AFB OH, March 1984.
- Dalton, Capt Kent B. "Missile Crewmember Attitudes on Scheduling at Malmstrom Air Force Base." A Graduate Research Project at Embry-Riddle Aeronautical University, Great Falls MT, 1994.
- Department of the Air Force. *Intercontinental Ballistic Missile (ICBM) Operations*. ACC Regulation 55-66, Headquarters Air Combat Command, 26 March 1993.
- Department of the Air Force. *ICBM Training and Standardization/Evaluation*. ACC Regulation 50-25, Headquarters Air Combat Command, 4 January 1993.
- Department of the Air Force. *Missile Crew Scheduling Information System Maintenance Manual*. SAC Manual 171-104 Volumes 1, Headquarters Strategic Air Command, 1 January 1991.
- Department of the Air Force. *Missile Crew Scheduling Information System Maintenance Manual*. SAC Manual 171-104 Volumes 3, Headquarters Strategic Air Command, 1 May 1992.
- Forbes, Capt Lance A. *Automated Operations Scheduling Using A Genetic Algorithm*. MS Thesis, Colorado State University, Fort Collins CO, 1993.
- French, Simon. *Sequencing and Scheduling: An Introduction of the Mathematics of the Job Shop*. London: Ellis Hardwood Ltd, 1982.
- Parker, Gary R., and Rardin, Ronald L. "An Overview of the Complexity theory in Discrete Optimizations: Part I. Concepts" *IIE Transactions*, 14 (1), (March 1982a).
- Wardle, Maj Donald. Chief, Operations Scheduling Division, 341 MW, Malmstrom AFB, MT. Point Paper on Missile Crew Scheduling Information System, 21 October 1993.

Vita

Captain Michael D. Shirley Jr. was born August 25, 1963 in Louisville, Kentucky. He attended the University of Kentucky, graduating with a Bachelor of Science in Economics in 1985. He was commissioned through Air Force ROTC and entered active duty in 1985. After initial training, he performed missile combat crew duties at Whiteman AFB, Missouri and Malmstrom AFB, Montana. Captain Shirley received a Masters in Aeronautical Science from Embry-Riddle Aeronautical University in 1991. His next assignment is to Air Mobility Command headquarters at Scott AFB, Illinois.

Permanent Address: 319 Old Towne Road
Louisville, Kentucky 40118

REPORT DOCUMENTATION PAGE

Form Approved
OMB No. 0704-0188

Public reporting burden for this collection of information is estimated to average 1 hour per response, including the time for reviewing instructions, searching existing data sources, gathering and maintaining the data needed, and completing and reviewing the collection of information. Send comments regarding this burden estimate or any other aspect of this collection of information, including suggestions for reducing this burden, to Washington Headquarters Services, Directorate for Information Operations and Reports, 1215 Jefferson Davis Highway, Suite 1204, Arlington, VA 22202-4302, and to the Office of Management and Budget, Paperwork Reduction Project (0704-0188), Washington, DC 20503.

1. AGENCY USE ONLY (Leave blank)		2. REPORT DATE December 1994	3. REPORT TYPE AND DATES COVERED Master's Thesis (Final)	
4. TITLE AND SUBTITLE AN IMPROVED HEURISTIC FOR INTERCONTINENTAL BALLISTIC MISSILE CREW SCHEDULING			5. FUNDING NUMBERS	
6. AUTHOR(S) Michael D. Shirley Jr., Capt, USAF				
7. PERFORMING ORGANIZATION NAME(S) AND ADDRESS(ES) Air Force Institute of Technology Wright-Patterson AFB OH 45333			8. PERFORMING ORGANIZATION REPORT NUMBER AFIT/GOA/ENS/94D-01	
9. SPONSORING/MONITORING AGENCY NAME(S) AND ADDRESS(ES) AFSPACECOM/DOTT 150 Vandenberg St Ste 1105 Peterson AFB CO 80914-4240			10. SPONSORING/MONITORING AGENCY REPORT NUMBER	
11. SUPPLEMENTARY NOTES				
12a. DISTRIBUTION / AVAILABILITY STATEMENT Approved for public release; distribution unlimited			12b. DISTRIBUTION CODE	
13. ABSTRACT (Maximum 200 words) Creating monthly schedules for missile crews is a complex and time consuming problem. Thousands of events must be scheduled for several hundred missile officers. The rules and regulations governing the problem are numerous, and there are currently no established measures for missile crew schedules. The scheduling software currently available only schedules a fraction of the events. The objectives of this research were to create a rule based heuristic which could quickly produce feasible or near-feasible schedules, to make the scheduling process paperless, and to develop possible measures of effectiveness for missile crew schedules. The research was successful in each of these areas. Schedules which comply with all rules and regulations were generated by the heuristic. From 95 to 100 percent of the required events were scheduled. The heuristic required from five to 40 seconds to create a schedule using hardware available at a missile wing. Spreadsheets were used to preprocess the data before it was input to the heuristic. This approach made the process paperless. Eight potential objectives which were previously not used as quality measures for missile crew schedules were obtained. These objectives along with those contained in regulations are supported by the rule based heuristic.				
14. SUBJECT TERMS Scheduling, Crews, Automatic Programming, Algorithms, Integer Programming, Heuristic Methods			15. NUMBER OF PAGES 115	
			16. PRICE CODE	
17. SECURITY CLASSIFICATION OF REPORT Unclassified	18. SECURITY CLASSIFICATION OF THIS PAGE Unclassified	19. SECURITY CLASSIFICATION OF ABSTRACT Unclassified	20. LIMITATION OF ABSTRACT UL	