

ARMY RESEARCH LABORATORY



High-Capacity Artillery Projectile (HICAP) Fin Characteristics

James M. Garner

ARL-MR-202

December 1994

REFERENCE COPY
DOES NOT CIRCULATE

OCT 1996

APPROVED FOR PUBLIC RELEASE; DISTRIBUTION IS UNLIMITED.

NOTICES

Destroy this report when it is no longer needed. DO NOT return it to the originator.

Additional copies of this report may be obtained from the National Technical Information Service, U.S. Department of Commerce, 5285 Port Royal Road, Springfield, VA 22161.

The findings of this report are not to be construed as an official Department of the Army position, unless so designated by other authorized documents.

The use of trade names or manufacturers' names in this report does not constitute endorsement of any commercial product.

REPORT DOCUMENTATION PAGE

Form Approved
OMB No. 0704-0188

Public reporting burden for this collection of information is estimated to average 1 hour per response, including the time for reviewing instructions, searching existing data sources, gathering and maintaining the data needed, and completing and reviewing the collection of information. Send comments regarding this burden estimate or any other aspect of this collection of information, including suggestions for reducing this burden, to Washington Headquarters Services, Directorate for Information Operations and Reports, 1215 Jefferson Davis Highway, Suite 1204, Arlington, VA 22202-4302, and to the Office of Management and Budget, Paperwork Reduction Project (0704-0188), Washington, DC 20503.

1. AGENCY USE ONLY (Leave blank)	2. REPORT DATE December 1994	3. REPORT TYPE AND DATES COVERED Final, October 1992-July 1994	
4. TITLE AND SUBTITLE High-Capacity Artillery Projectile (HICAP) Fin Characteristics		5. FUNDING NUMBERS PR: 1L162618AH80	
6. AUTHOR(S) James M. Garner			
7. PERFORMING ORGANIZATION NAME(S) AND ADDRESS(ES) U.S. Army Research Laboratory ATTN: AMSRL-WT-PB Aberdeen Proving Ground, MD 21005-5066		8. PERFORMING ORGANIZATION REPORT NUMBER	
9. SPONSORING / MONITORING AGENCY NAME(S) AND ADDRESS(ES) U.S. Army Research Laboratory ATTN: AMSRL-OP-AP-L Aberdeen Proving Ground, MD 21005-5066		10. SPONSORING / MONITORING AGENCY REPORT NUMBER ARL-MR-202	
11. SUPPLEMENTARY NOTES			
12a. DISTRIBUTION / AVAILABILITY STATEMENT Approved for public release; distribution is unlimited.		12b. DISTRIBUTION CODE	
13. ABSTRACT (Maximum 200 words) One of the key technologies being developed for the High-Capacity Artillery Projectile (HICAP) is an out of bore deployable fin assembly. The fin assembly must stabilize the projectile and maintain the reduced spin level imparted by the slip obturator. The design described herein uses a rearward opening, foldout fin. This fin has acceptable aerodynamic characteristics and deploys utilizing the projectile spin imparted from the obturator. The fin blades are concealed during launch in a base module that is easily obturated. This report contains design factors, predicted aerodynamics, and results from the fin opening tests.			
14. SUBJECT TERMS folding fins, HICAP, aerodynamics, projectiles			15. NUMBER OF PAGES 17
			16. PRICE CODE
17. SECURITY CLASSIFICATION OF REPORT UNCLASSIFIED	18. SECURITY CLASSIFICATION OF THIS PAGE UNCLASSIFIED	19. SECURITY CLASSIFICATION OF ABSTRACT UNCLASSIFIED	20. LIMITATION OF ABSTRACT UL

INTENTIONALLY LEFT BLANK.

ACKNOWLEDGMENTS

The author extends thanks to Elisa Jara for her graphical, organizational, and editorial skills; Emily Hsi for her proofreading skills; and Robert Kaste, James Bender, and Nathan Gerber for their technical assistance on this report.

INTENTIONALLY LEFT BLANK.

TABLE OF CONTENTS

	<u>Page</u>
ACKNOWLEDGMENTS	iii
LIST OF FIGURES	vii
1. INTRODUCTION	1
2. BASE MODULE REQUIREMENTS	2
3. FIN DESIGN	2
4. AERODYNAMICS	5
5. CONCLUSIONS	8
6. REFERENCES	9
DISTRIBUTION LIST	11

INTENTIONALLY LEFT BLANK.

LIST OF FIGURES

<u>Figure</u>		<u>Page</u>
1.	Simplified overall HICAP configuration	2
2.	Stowed and open configurations of the HICAP base module	3
3.	Fin opening rate ($\dot{\theta}$) vs. time	5
4.	Drag coefficient vs. Mach number	6
5.	HICAP trajectory height vs. range	7
6.	Moment coefficient vs. Mach number	8

INTENTIONALLY LEFT BLANK.

1. INTRODUCTION

The High-Capacity Artillery Projectile (HICAP) project is a joint venture between the U.S. Army Research Laboratory (ARL), Aberdeen Proving Ground, MD, and the U.S. Army Armament Research, Development, and Engineering Center (ARDEC), Picatinny Arsenal, NJ. The goal of the HICAP program is to generate double the lethality of conventional artillery projectiles at equal or greater ranges. HICAP must also be compatible with the present inventory of 155-mm gun tubes.

In June 1993, representatives from ARL's Propulsion and Flight Division (PFD) rejected a square-based HICAP design proposed by Kayser (1992). The design offered several technological challenges in obturation and was considered too expensive to develop into a reliable projectile. This square-based projectile design was originated to accommodate Kayser's novel folding fins that were aerodynamically efficient and manufacturable. Unfortunately, the fin blade design was predicated on a square-based geometry, and the requirement of minimal case intrusion created the need for a simpler base module design that produces satisfactory obturation, provides acceptable aerodynamics, and meets artillery projectile safety requirements.

The HICAP is a two-piece projectile. It is fully assembled when the aft stage is rammed into the rear of the front stage and locks. The task of designing a base module (the rear portion of the aft stage) that houses the fin, supports the obturator, and is compatible with 155-mm projectile length and mass specifications was performed by PFD. This report focuses on both the fin design and the operation of the fin during a field test.

HICAP uses a six-blade fin configuration to stabilize a roughly 12 to 1 length-to-diameter (L/D) ratio projectile. As payload volume increases, a longer body is needed to deliver the payload (assuming the same caliber gun is used). The typical artillery projectile is spin stabilized. Large L/D spin-stabilized projectiles develop sizeable Magnus forces, which tend to cause the projectile to veer off course. The larger the L/D, the greater the Magnus effect. A HICAP program goal is to create a fin-stabilized, all-composite structure (to include the base module and fins) that can be fired from the rifled 155-mm M199 gun tube. The use of composites allows a larger fraction of the total weight to consist of payload. Figure 1 illustrates the rear module; the fore sections of the projectile have been simplified.

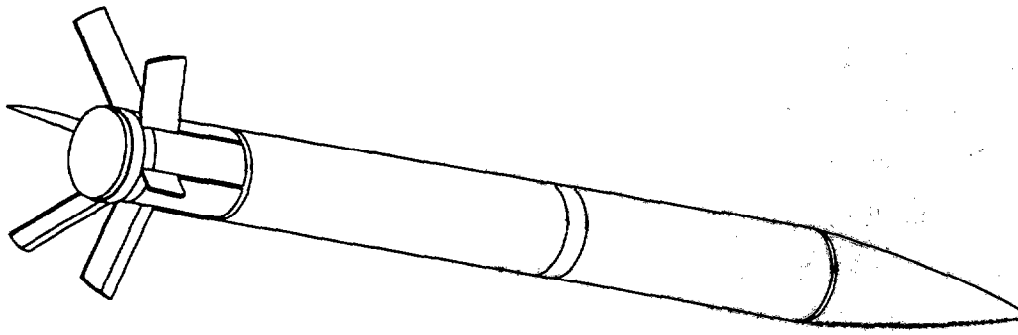

Figure 1. Simplified overall HICAP configuration.

2. BASE MODULE REQUIREMENTS

The HICAP base module had to meet several requirements to be considered acceptable. Some of the more pertinent requirements are as follows:

- Nothing can be discarded from the projectile before payload dispersal (i.e., no pusher plates [lightweight plastic rotating bands exempted]).
- The entire base module can be no longer than 11 in (based on front and rear module designs).
- The fins must give adequate stability from Mach (M) 2.2 to subsonic velocities and must have acceptable drag characteristics.
- The fin must be stowed while in the barrel and deploy upon muzzle exit.
- The fin must maintain sufficient spin for payload dispersal.

3. FIN DESIGN

Many factors were considered when creating the HICAP fin. Most of these are shown in Figure 2. The fin blade length and aspect ratio were chosen not only to satisfy stability and drag requirements, but also to survive aerodynamic bending forces as well. Perhaps the most critical part of the fin design is the placement of the blade pivot point and locking hole in relation to the fin center of gravity (Fcg). When

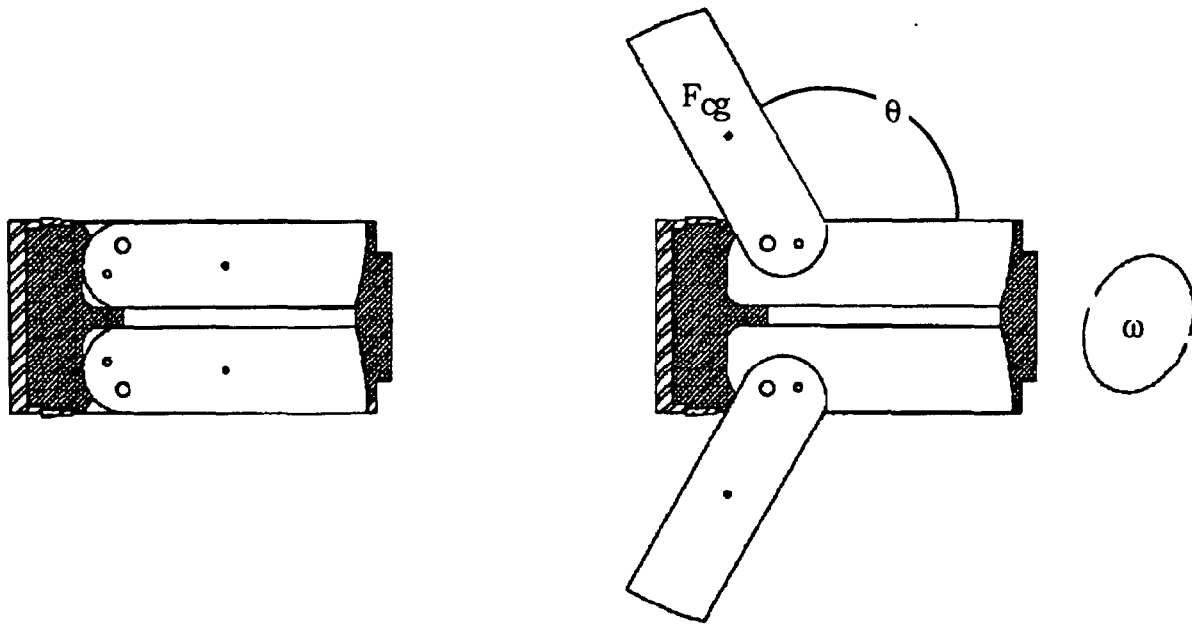

Figure 2. Stowed and open configurations of the HICAP base module.

in the stowed position, the F_{cg} is below the fin pivot point in relation to the projectile axis. This ensures that while the projectile accelerates, the fins will be subject to a moment that keeps them closed while in-bore. Once the projectile exits the gun, the acceleration force is substantially removed and the fins open under the centrifugal force created by the spin that results from the normal rifling process. The acceleration rate (which creates the fin closing moment) that balances the centrifugal opening moment is 750 g's ($g = 9.81 \text{ m/s}^2$). This assumes a projectile spin rate of 5 Hz. The acceleration at muzzle exit is approximately 2,000 g's, so the fins should remain closed in-bore. The positioning of the fin blade pivot point can change the exposed blade area when the blade is extended in position. A lower pivot point (one closer to the projectile centerline) results in less exposed blade area. The exposed area can vary by as much as 20% based on the pivot point location. The fin blade rotates through an angle (θ) of 120° before locking into position at a 60° angle to the projectile body. The fin blade length and span are limited by physical dimensions of the base module and the bore.

The forces required to stop the fin blade at the locked position were also considered. A very rapid fin deployment might cause the blades to bounce off the stop and either fail to lock or damage the blade. A differential equation simulating the fin motion was created and solved with the boundary conditions

(BCs): $\theta = 0$ at time = 0, and $\dot{\theta} = 0$ at time = 0. Based on these BCs, estimates of the fin velocity at the stop are shown in Figure 3 for a projectile spin rate of 5 Hz. Damage should not occur, assuming an aluminum fin, until a fin opening rate of 50 Hz occurs. Frictional forces were not modeled in the simulation equation. Composite fins and a composite base section may alter the allowable spin rate due to the fracture sensitivity of the materials and composite layups used. The following differential equation was used as a first estimate of the angular acceleration of the fin about its pivot (fin opening).

$$\ddot{\theta} = \frac{f_m \omega^2 (r_p + f_{arm} \sin \theta) \cos \theta f_{arm} + D f_{arm} \sin \theta}{I_{fin}}$$

θ = the angle between the fin centerline and the projectile centerline.

I_{fin} = the moment of inertia of the fin.

ω = the angular rate of the projectile.

f_{arm} = the horizontal distance from the fin pivot to the F_{cg} at $\theta = 0$.

f_m = the fin mass.

r_p = the distance from the projectile centerline to pivot.

D = drag force on fin.

A form of the equation was used without the drag term and matched to the results of a spin test at the Transonic Range (TR). The spin test did not simulate aerodynamic effects. This was considered a reasonable approximation, since the drag term on the right side of the equation is considerably smaller than the centrifugal force based first term. Tests were conducted to estimate how quickly the fins deployed under the expected spin conditions and to detect any resulting damage. This modified equation was verified as the opening rate, $\dot{\theta}$, and the times required to open measured in the TR test were very close to the computed values. Figure 3 shows the results obtained from the computed values.

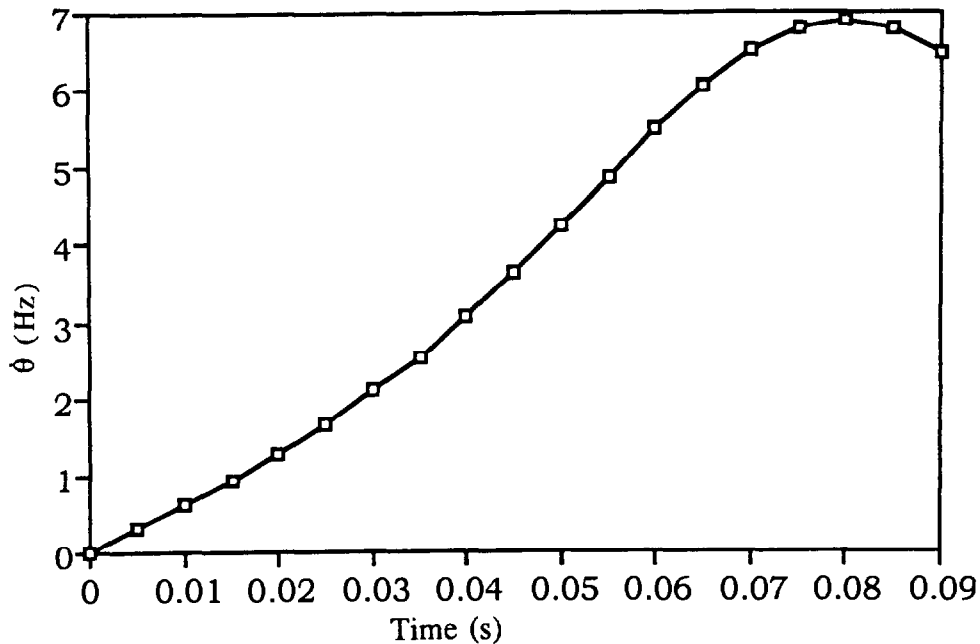

Figure 3. Fin opening rate (θ) vs. time.

The fin blade lock mechanism must function for the fin blade to perform as intended. A 0.67-cm-diameter hole perpendicular to the fin contains a detent pin. The locking mechanism is composed of a spring-loaded dowel (detent pin) and a set screw. The dowel engages, as the smaller hole (shown in Figure 2) on the fin blade rotates in front of the pin. The dowel is tapered, and the fin blade hole is counterbored to aid in the locking process. The spring force can be changed by adjusting the set screw.

4. AERODYNAMICS

The drag characteristics of the projectile significantly impact total range. Figure 4 shows the drag coefficient vs. Mach number. This plot shows the typical peak at Mach 1 and a more gradual decline with increasing Mach number. The potential exists to reduce the fin drag of the HICAP by using fewer fin blades.

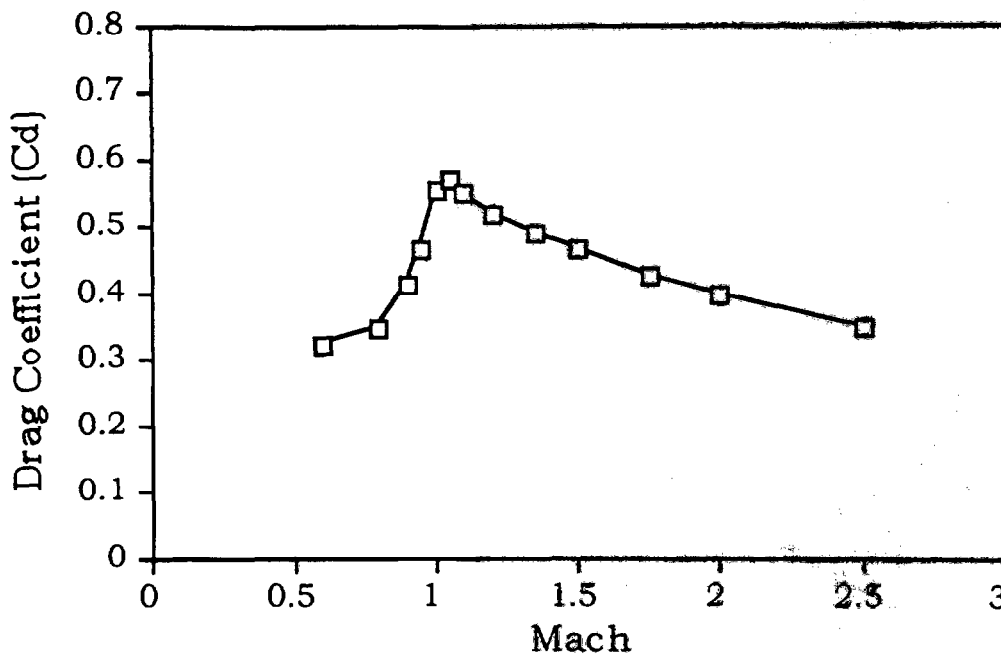

Figure 4. Drag coefficient vs. Mach number.

Of course this decreases the stability of the projectile at higher Mach numbers and can result in larger average projectile yaws. Large yaw magnitudes increase drag and decrease range. Clearly, a tradeoff exists between required stability, drag, and range. Minimizing the fin thickness also reduces drag. Very thin fins bend too much under aerodynamic loads, which is unacceptable. Ultra stiff composite fins offer drag reduction, but their use is uncertain due to their fracture properties. The present HICAP fin blades are aluminum and relatively uncomplicated. The maximum projected range available with this fin is about 18 km. The blades are beveled to reduce drag and produce a 10-15-Hz projectile spin rate. A HICAP composite fin of the same planform is scheduled for testing at a later date.

Figure 5 compares the maximum projected HICAP range using the fin suggested by Kayser vs. those of the present design. The fin area of the present design is 90% of the Kayser fin. The Kayser design achieves a lower drag through the use of a smaller projectile base area coupled with an effective fin scheme. Although this option is difficult to obturate and spin at 10-20 Hz simultaneously, future improvements could make it more viable.

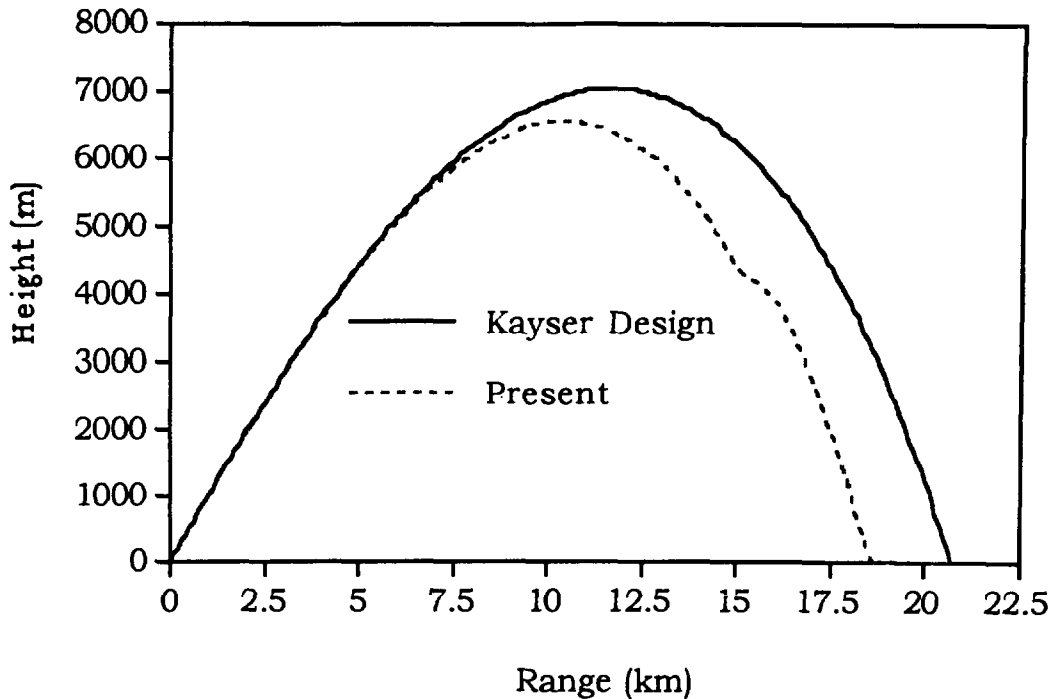

Figure 5. HICAP trajectory height vs. range.

The graph of the present fin design trajectory height vs. range in Figure 5 shows a "bump" at between 15 and 17.5 km. The trajectory program used to create this plot relies on aerodynamic code predictions and/or range data. HICAP has only code predictions for aerodynamics thus far. Plans exist to obtain empirical HICAP aerodynamic data through testing at the TR. When working with aerodynamic predictive codes, various schemes are used to obtain projectile characteristics at different Mach numbers. This bump is likely due to the transition between two schemes. The overall effect on the range is minimal.

Figure 6 shows the moment coefficient ($C_{m\alpha}$) vs. Mach number variation for the proposed fin configuration. The primary purpose of the fin blade is to provide stability over the Mach number range that the projectile encounters in flight. Moment coefficients ($C_{m\alpha}$'s) of -10 to -15 are common for fin-stabilized, aerodynamically well-behaved projectiles. Figure 6 indicates that HICAP has good stability at $M = 2.2$ and further shows acceptable stability up to $M = 2.5$. This allows for future moderate increases in launch velocity without a fin redesign. These increases in launch velocity are likely, considering technologies such as liquid propulsion and electromagnetic launch.

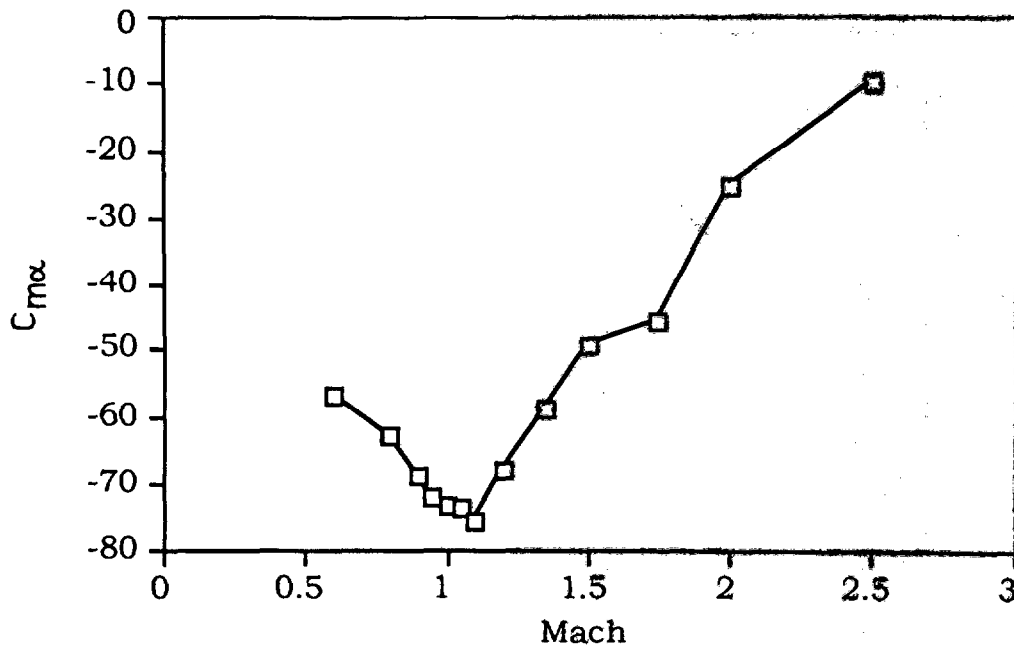

Figure 6. Moment coefficient vs. Mach number.

5. CONCLUSIONS

The latest HICAP design is obturable, mechanically simple, and has acceptable drag characteristics. Its design allows the fin blades to remain closed while in-bore and open and lock once the projectile exits the muzzle. Furthermore, the design meets the artillery discard criteria and safety concerns. Currently, efforts exist to substitute composites for aluminum in the basic design and improve stability and lighten the projectile. The HICAP projectile design represents a significant step forward in the use of composites in the artillery regime. A practical stabilizing base module is essential.

6. REFERENCES

Kayser, L. D., and T. G. Brown. "Fin Motion After Projectile Exit From Gun Tube." BRL-TR-3375, U.S. Army Ballistic Research Laboratory, Aberdeen Proving Ground, MD, July 1992.

Brown, T. G. "Free-Flight Yawsonde Tests of the M712 Copperhead Projectile." BRL-MR-3798, U.S. Army Ballistic Research Laboratory, Aberdeen Proving Ground, MD, November 1989.

INTENTIONALLY LEFT BLANK.

<u>NO. OF COPIES</u>	<u>ORGANIZATION</u>
2	ADMINISTRATOR DTIC ATTN DTIC DDA CAMERON STATION ALEXANDRIA VA 22304-6145
1	CDR USAMC ATTN AMCAM 5001 EISENHOWER AVE ALEXANDRIA VA 22333-0001
1	DIR USARL ATTN AMSRL OP SD TA RECORDS MGMT 2800 POWDER MILL RD ADELPHI MD 20783-1145
3	DIR USARL ATTN AMSRL OP SD TL TECH LIB 2800 POWDER MILL RD ADELPHI MD 20783-1145
1	DIR USARL ATTN AMSRL OP SD TP TECH PUBS BR 2800 POWDER MILL RD ADELPHI MD 20783-1145
2	CDR US ARMY ARDEC ATTN SMCAR TDC PICATINNY ARSNL NJ 07806-5000
1	DIR BENET LABS ATTN SMCAR CCB TL WATERVLIET NY 12189-4050
1	DIR USA ADVANCED SYSTEMS R&A OFC ATTN AMSAT R NR MS 219 1 AMES RESEARCH CENTER MOFFETT FIELD CA 94035-1000
1	CDR US ARMY MICOM ATTN AMSMI RD CS R DOC REDSTONE ARSNL AL 35898-5010
1	CDR US ARMY TACOM ATTN AMSTA JSK ARMOR ENG BR WARREN MI 48397-5000

<u>NO. OF COPIES</u>	<u>ORGANIZATION</u>
1	DIR USA TRADOC ANALYSIS CMD ATTN ATRC WSR WSMR NM 88002-5502
1	CMDT US ARMY INFANTRY SCHOOL ATTN ATSH CD SECURITY MGR FORT BENNING GA 31905-5660
	<u>ABERDEEN PROVING GROUND</u>
2	DIR USAMSA ATTN AMXSY D AMXSY MP H COHEN
1	CDR USATECOM ATTN AMSTE TC
1	DIR USAERDEC ATTN SCBRD RT
1	CDR USACBDCOM ATTN AMSCB CII
1	DIR USARL ATTN AMSRL SL I
5	DIR USARL ATTN AMSRL OP AP L

NO. OF
COPIES ORGANIZATION

ABERDEEN PROVING GROUND

9 DIR USARL
ATTN AMSRL WT PD
J BENDER
B BURNS
H EDGE
J GARNER
N GERBER
D SAVICK
E SCHMIDT
AMSRL WT WC
E JARA
R VON WAHLDE

USER EVALUATION SHEET/CHANGE OF ADDRESS

This Laboratory undertakes a continuing effort to improve the quality of the reports it publishes. Your comments/answers to the items/questions below will aid us in our efforts.

1. ARL Report Number ARL-MR-202 Date of Report December 1994

2. Date Report Received _____

3. Does this report satisfy a need? (Comment on purpose, related project, or other area of interest for which the report will be used.) _____

4. Specifically, how is the report being used? (Information source, design data, procedure, source of ideas, etc.) _____

5. Has the information in this report led to any quantitative savings as far as man-hours or dollars saved, operating costs avoided, or efficiencies achieved, etc? If so, please elaborate. _____

6. General Comments. What do you think should be changed to improve future reports? (Indicate changes to organization, technical content, format, etc.) _____

**CURRENT
ADDRESS**

Organization

Name

Street or P.O. Box No.

City, State, Zip Code

7. If indicating a Change of Address or Address Correction, please provide the Current or Correct address above and the Old or Incorrect address below.

**OLD
ADDRESS**

Organization

Name

Street or P.O. Box No.

City, State, Zip Code

(Remove this sheet, fold as indicated, tape closed, and mail.)
(DO NOT STAPLE)

DEPARTMENT OF THE ARMY

OFFICIAL BUSINESS



NO POSTAGE
NECESSARY
IF MAILED
IN THE
UNITED STATES

BUSINESS REPLY MAIL
FIRST CLASS PERMIT NO 0001, APG, MD

Postage will be paid by addressee

Director
U.S. Army Research Laboratory
ATTN: AMSRL-OP-AP-L
Aberdeen Proving Ground, MD 21005-5066

