

DEPARTMENT OF  
**NAVAL ARCHITECTURE &  
OFFSHORE ENGINEERING**

Inspection Methods for Underwater Cables

by

Robin Young Noyes

**S** DTIC  
ELECTE  
JAN 10 1995  
**G** **D**

Master of Engineering Thesis  
December 14, 1994

19950109 132

DTIC QUALITY INSPECTED

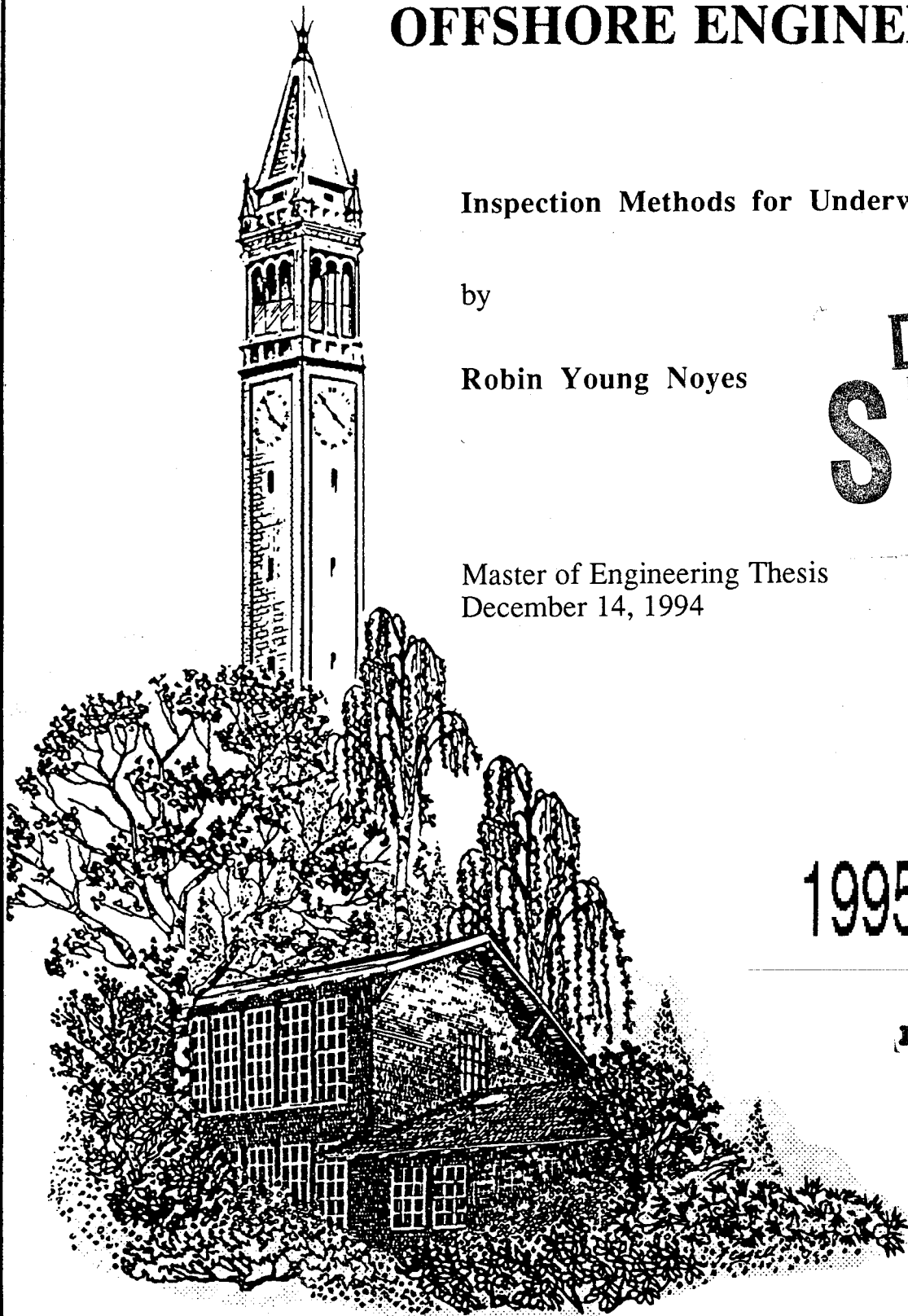

UNIVERSITY OF CALIFORNIA, BERKELEY, CA 94720

Tel. (510) 642-5464

DISTRIBUTION STATEMENT A

Approved for public release;  
Distribution Unlimited

Telefax (510) 642-6128

Inspection Methods for Underwater Cables

by

Robin Young Noyes

B.S. (United States Naval Academy) 1987

A thesis submitted in partial satisfaction of the

requirements for the degree of

Master of Engineering

in

Engineering - Naval Architecture & Offshore Engineering

in the

GRADUATE DIVISION

of the

UNIVERSITY OF CALIFORNIA at BERKELEY

Committee in charge:

Professor Laura A. Demsetz, Chair  
Professor Robert G. Bea  
Professor Ronald W. Yeung

1994

**DISTRIBUTION STATEMENT A**  
Approved for public release;  
Distribution Unlimited

Accession For	
NTIS CRA&I	<input checked="" type="checkbox"/>
DTIC TAB	<input type="checkbox"/>
Unannounced	<input type="checkbox"/>
Justification	<i>per form 50</i>
By _____	
Distribution /	
Availability Codes	
Dist	Avail and/or Special
<i>A-1</i>	

The thesis of Robin Young Noyes is approved:

Law Denny 12/9/94  
Chair Date

J. H. Kea 7/12/94  
Date

Ronald W. Young 12/12/94  
Date

University of California at Berkeley

1994

## ACKNOWLEDGMENTS

A special thanks is extended to those who made my study at U.C. Berkeley possible: to the U.S. Navy, for providing me with the opportunity to attend graduate school, and to those Navy individuals in the Ocean Facilities Program and at Underwater Construction Team Two who gave generously of their time and assistance; to my committee members, for their valuable time and careful review, especially my advisor, Professor Laura Demsetz; and of course to my husband Brian, for always caring and supporting what I do.

## TABLE OF CONTENTS

ACKNOWLEDGMENTS .....	iii
LIST OF FIGURES .....	vii
LIST OF TABLES .....	ix
CHAPTER 1 INTRODUCTION .....	1
1.1 Purpose of Underwater Cables	
1.2 Hazards to Underwater Cables	
1.3 Cable Inspection	
1.4 Purpose of Report	
1.5 Contents of Report	
CHAPTER 2 CURRENT CABLE INSPECTION METHODS.....	7
2.1 Underwater Cable Types	
2.2 Inspection Levels	
2.3 Cable Inspection Method	
2.3.1 Cable Survey	
2.3.2 Cable Inspection	
2.4 Inspection Equipment	
2.4.1 Survey Equipment	
2.4.2 Diver Equipment	
2.4.3 Surface Vessels	
2.4.4 Underwater Tools	

2.5	Inspection Recording Procedures	
2.6	Personnel and Training Required for Inspections	
<b>CHAPTER 3 OPPORTUNITIES FOR IMPROVEMENT IN CURRENT</b>		
	<b>CABLE INSPECTION METHODS</b> .....	<b>35</b>
3.1	Cable Location and Surveying Difficulties	
3.2	Human Limitations	
3.3	Weather Difficulties	
3.4	Summary of Opportunities for Improvement	
<b>CHAPTER 4 ASSESSMENT METHOD</b> .....		
		<b>45</b>
4.1	Evaluation Criteria	
4.2	Assessment Process	
4.3	Assessment Format	
4.4	Datum for Comparison	
4.5	Assessment of Alternatives	
<b>CHAPTER 5 ALTERNATIVES TO INSPECTION</b> .....		
		<b>56</b>
5.1	Periodic Maintenance or Cable Replacement	
5.2	Self-Inspecting Cables	
5.3	Improved Cable Siting	
5.4	Assessment	
<b>CHAPTER 6 INVESTIGATION OF TECHNOLOGY TO IMPROVE CABLE</b>		
	<b>INSPECTIONS</b> .....	<b>71</b>
6.1	Cable Survey Using a Global Positioning System (GPS)	

6.1.1	Fundamentals of Global Positioning	
6.1.2	Capabilities of GPS and Differential GPS (DGPS)	
6.1.3	GPS Assessment	
6.2	Active Cable Location	
6.2.1	Geophysical Methods	
6.2.2	Radar	
6.2.3	Active Cable Location Assessment	
6.3	Passive Cable Location	
6.3.1	Magnetometers/Gradiometer Arrays	
6.3.2	Acoustic Cable Markers	
6.3.3	Visual Cable Markers	
6.3.4	Passive Cable Location Assessment	
6.4	Remotely Operated Vehicles (ROVs)	
6.4.1	ROV Types	
6.4.2	ROV Assessment	
CHAPTER 7	SUMMARY AND CONCLUSIONS.....	122
REFERENCE LIST.....		126

## LIST OF FIGURES

Figure		Page
2-1	Typical Coaxial Cables .....	8
2-2	Fiber Optic Cables .....	11
2-3	Split Pipe.....	13
2-4	Rock bolt .....	13
2-5	Pin Anchor and Strap .....	14
2-6	Typical Brass Tag Marker .....	19
2-7	Leap Frog Method .....	20
2-8	Circling Method of Visual Location.....	21
2-9	Triangulation Survey Method .....	22
2-10	LARC V Vessel.....	28
2-11	Metal Locator Tool.....	29
2-12	Diver Propulsion Vehicle.....	30
3-1	Human Performance Function .....	41
4-1	Sea States.....	53
5-1	Cost Based Evaluation of Desirable IMR Quality.....	58
5-2	AT&T Undersea Lightwave Transmission System .....	62
6-1	Global Positioning System Network .....	73

6-2	Side Scan Sonar in Operation .....	85
6-3	Representation of a Diffraction Hyperbola .....	86
6-4	Gradiometer Array Schematic.....	98
6-5	Sketch of Three Dimensional Scour Process and Self-Burial .....	101
6-6	Anatomy of a Pinger.....	102
6-7	Hydrophone Receiver .....	103
6-8	Deadweight Anchors .....	105

## LIST OF TABLES

Table		Page
2-1	Coaxial Cable Characteristics.....	9
2-2	Fiber Optic Cable Characteristics.....	10
2-3	Inspection Levels.....	16
2-4	Matrix of Types of Cable Damage.....	24
2-5	Documentation of Damage to Cables.....	25
4-1	Evaluation Criteria.....	46
4-2	Assessment Format.....	50
6-1	General Characteristics of Geophysical Sensors.....	83
6-2	UCT ROV System Specifications.....	114
6-3	Shipping Requirement Comparison.....	114
7-1	Overall Assessment.....	123

# CHAPTER 1

## INTRODUCTION

### 1.1 Purpose of Underwater Cables

Underwater cables serve many purposes, both military and commercial. The most common use of underwater cables is for telecommunications, where voice is transformed into either electrical current or pulses of laser light which are transmitted across the world's oceans via underwater cables. The military uses underwater cables in several ways in support of national defense. Hydrophone arrays deployed from underwater cables form an extensive integrated undersea surveillance system (IUSS) which is used to monitor the activities of submarines. The military also uses underwater cables for training, testing, and evaluation ranges in the ocean. These ranges use transponder units to track air, surface, and submerged targets for purposes such as measuring surface ship radiated noise or evaluating weapons systems accuracy. The underwater cables provide the means to transmit communications and data to control facilities.

The end of the cold war created numerous opportunities to use military resources for environmental and scientific research. In 1990, Congress established the Strategic

Environmental Research and Development Program (SERDP), which focuses Department of Defense research assets towards environmental issues (Oswald 1993). As a result of this program, the Navy's undersea acoustic surveillance system, or IUSS, can now be used for a variety of scientific purposes. For example, IUSS allows researchers to go offshore into deep water to monitor whales. Past study of whales was primarily conducted on captive animals or from observations made in coastal areas. Long term field observation of whales in the deep ocean regions by plane or ship was not possible due to prohibitive costs. With access to IUSS, scientists are now able to gather data to establish whale population and migration patterns (Nishimura and Conlon 1993).

Underwater cable hydrophone arrays are also useful in detecting low-level seismicity in the ocean. Undersea acoustic systems can monitor seismic activity levels along the mid-ocean ridges at detection sensitivities significantly better than the Global Seismic Network (Fox and others 1993). Another application for an underwater acoustic system is to stem illegal ocean activities. IUSS can monitor fishing vessels involved in illegal drift net fishing or whaling banned by international agreement (Oswald 1993).

## **1.2 Hazards to Underwater Cables**

Underwater cables may be subjected to many different forms of damage. Hazards to the cables may be either man-made or caused by the ocean environment. Man-made hazards and environmental hazards can be equally damaging to underwater cable systems.

Examples of man-made hazards include dropped anchors, dragging anchors, or fishing and trawling activities. From discussions with Navy personnel responsible for maintaining underwater cables, in nearly all cases of a cable entangled in fishing gear, the cable is simply cut by the fisherman and the incident goes unreported until a disruption in cable service is noted.

Environmental damage to cables includes natural forces such as wave and current action, storm surge and surf, soil movements resulting from earthquakes, scouring, ice, and marine organisms. The most common damage to underwater cables occurs from movement of the cable (Berian 1994). Movement results in abrasion to the outer coatings and protective armor of the cable.

Soil movement can be harmful to underwater cables in several ways. Scouring, or the removal of sea floor soils due to wave and current action, is harmful to underwater cables when it exposes previously buried cables and subjects them to abrasion from rocks and gravel. Scouring under a cable can also lead to unsupported spans along the cable which greatly increases the bending stresses in the cable. Longer areas of spanning are detrimental due to vortex induced vibrations and strumming. Significant damage or loss of the cable can result from vortices exciting the flexural natural frequencies of the cable. Spanning is particularly troublesome in areas where rock outcrops occur since the rocks can form pinnacles under the cable.

Soil or earth-mass movements such as those caused by earthquakes are harmful to cables when a significant shift in soil crushes a cable. Ice can also harm marine cables in several ways. The "keel" or bottom of floating ice can scour the sea floor and drag across or drag up a cable. Ice is also a danger when it encases a cable and then dislodges the cable when the ice mass shifts.

### **1.3 Cable Inspection**

Given the harsh environment of the ocean, inspections of cables are important for two reasons. First, inspections are performed to confirm and limit expected degradation. Secondly, inspections are also done to investigate that which is not expected. In light of the hazards to underwater cables, inspections are important to assess risk of damage and determine the extent of repairs. The overall goal of inspection is to minimize future maintenance and repair costs while meeting basic safety and reliability requirements.

The U.S. Navy has two specialized units to inspect its underwater cable systems. These units are Underwater Construction Team One (UCT One), located on the east coast, and Underwater Construction Team Two (UCT Two) on the west coast. The Teams have responsibility for a variety of harbor, waterfront, and ocean construction and repair projects. On an annual basis, cable installation, inspection, and repair comprises over twenty percent of the workload of the Teams (Black 1986). Since their official establishment in 1973, the workload of the Teams has expanded considerably both in

number and complexity of projects. Each year, the Teams receive more requests for underwater work than they have the time and resources to perform. With an overall decrease in military spending, it is highly unlikely that the Teams will receive more manpower to keep up with their expanding workload. The alternative is to devise ways to perform inspections more efficiently.

#### **1.4 Purpose of Report**

The purpose of this report is to review the current method used by Navy UCTs to inspect underwater cables, and explore different ways in which the process can be improved. Once areas of improvement are identified, various alternatives or technologies can be assessed and compared to the current cable inspection process. The goal of assessing and comparing different inspection methods to the current practice is to improve the current practice in terms of factors such as cost, efficiency, or safety. UCT responsibilities are normally limited to water depths of 100 feet. As such, the scope of this report is limited to water depths up to 100 feet.

#### **1.5 Contents of Report**

Chapter 2 reviews the current cable inspection process and equipment used by the Navy's Underwater Construction Teams. Since the writing of this report did not coincide with any unclassified cable inspections, observing an actual inspection first-hand was not

possible. However, interviews were conducted with personnel who have many years of experience performing the inspections. Chapter 3 analyzes the current practice, focusing on ways in which the inspection process may be improved. A qualitative method of assessing new techniques for inspection is presented in Chapter 4. Chapter 5 discusses several alternatives for ensuring cable integrity without performing inspections, such as cable replacement, periodic maintenance, self-inspecting cables, or improved routing of cables. Chapter 6 investigates possible ways to improve the inspection, with emphasis on cable location methods. Lastly, the summary and conclusions of this work are presented in Chapter 7.

## CHAPTER 2

### CURRENT CABLE INSPECTION METHODS

This chapter describes the current methods and equipment employed by the Navy's Underwater Construction Teams (UCTs) to inspect underwater cable systems. The information in this chapter was drawn in large part from interviews with divers at UCT Two in Port Hueneme, California, and from Navy Manual NAVFAC P-990, Conventional Underwater Construction and Repair Techniques (NAVFAC, 1978).

#### 2.1 Underwater Cable Types

The Navy's UCTs are tasked to inspect a variety of underwater cables located throughout the world. The teams' responsibility for cable inspection is limited to nearshore cables that connect deep sea cables, offshore platforms, or underwater devices to onshore terminals. "Nearshore" is defined by the UCTs as one nautical mile from shore or 100 feet of water depth, where cables are at highest risk of damage. The majority of cables in inventory are coaxial electromechanical and signal cables which range in diameter from approximately one to four inches. Typical coaxial cables are shown in Figure 2-1. Table 2-1 summarizes various properties of the cables.

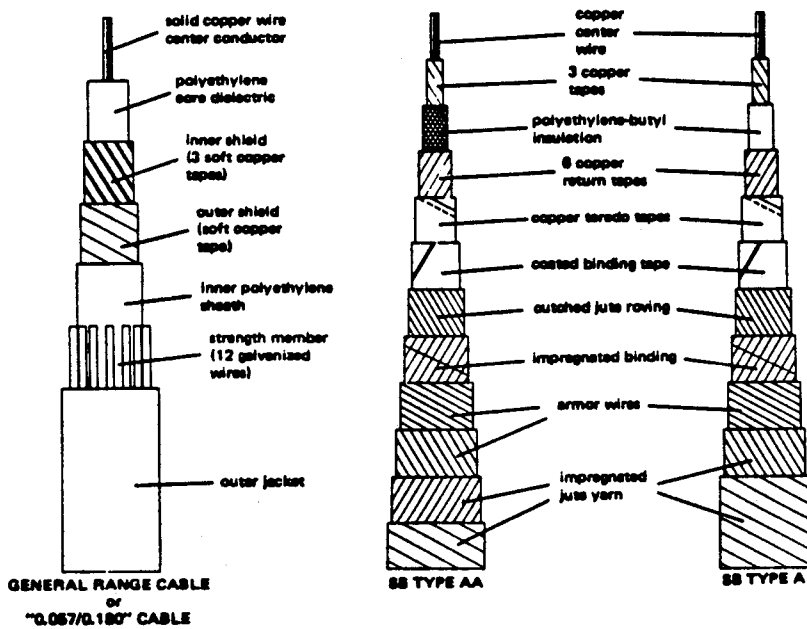
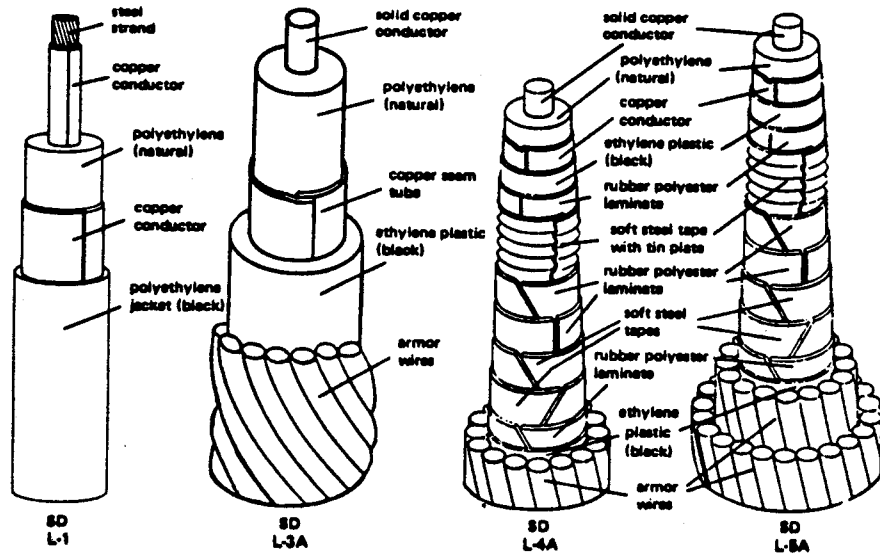

Figure 2-1. Typical Coaxial Cables (NAVFAC P-990 1978).

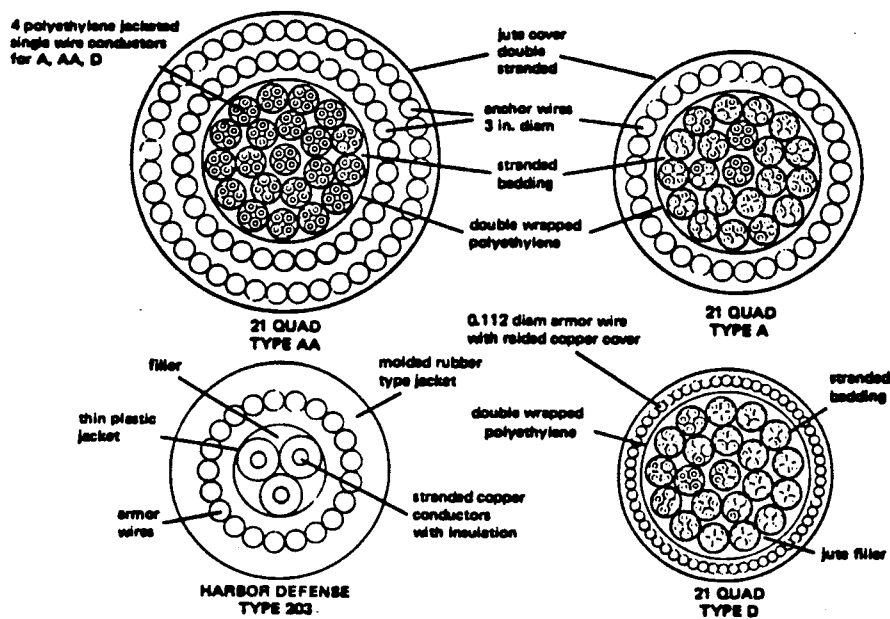

Figure 2-1 Continued.

TABLE 2-1

COAXIAL CABLE CHARACTERISTICS

Cable Type	Overall Diameter (inches)	Armor Diameter (inches)	Air Weight (lb/ft)	Water Weight (lb/ft)	Breaking Strength (1,000 lb)	Bending Radius (ft)
SD Coax List 1	1.25	none	0.87	0.32	17	3
List 3A	2.21	0.3	5.27	3.54	56.5	3
List 4A	2.72	0.3	7.26	5.26	48.5	3
List 5A	3.5	0.3	14.7	11.4	168.9	3
SB Coax AA	2.67	0.3	9.2	7	130	3
A	1.83	0.3	4.1	2.8	42.4	3
General Range Cable	1.07	0.04	0.24	0.09	4	3.5
Harbor Defense Type 203	1.6	0.13	2.4	1.5	15	3
21 Q AA	4.41	0.3	20.6	13.9	230	5
21 Q A	4.04	0.3	11.0	7.6	102	5
21 Q D	3.12	0.11	5.2	2.8	120	5

Source: NAVFAC P-990 1978

In more recent years, cable technology has advanced to fiber optic cables. An optical fiber is a small glass fiber that acts as a guide for light waves. The core of the glass fiber is a tube which keeps light signals internally reflected as they travel along the fiber. Due to its small size, an optical fiber can carry many times more communication channels than coaxial cables of the same diameter. Table 2-2 lists various characteristics of several types of fiber optic cables used by the Navy. The light armor and heavy armor fiber optic cables are depicted in Figure 2-2.

TABLE 2-2  
FIBER OPTIC CABLE CHARACTERISTICS

Cable Type	Overall Diameter (inches)	Air Weight (lb/ft)	Wet Weight (lb/ft)	Breaking Strength (1,000lb)	Bending Radius (ft)
FDS Deep Water Trunk	0.525	0.237	0.159	8,000	1.75
FDS Light Armor Trunk	0.910	0.890	0.610	57,000	1.75
FDS Medium Armor Trunk	1.84	3.8	2.8	60,000	3.0
FDS Heavy Armor Trunk	2.66	8.9	6.5	120,000	5.0
ARIADNE/ADI Shore Landing Cable	0.50	0.278	0.191	18,000	2.0
ARIADNE Trunk	0.093	0.00848	0.00539	600	1.0

Source: NAVFAC P-990 1994

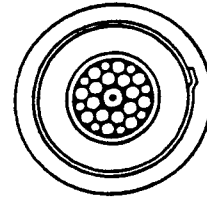
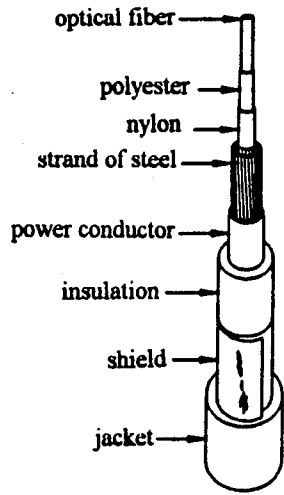

Light Armor Trunk

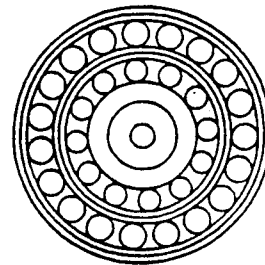
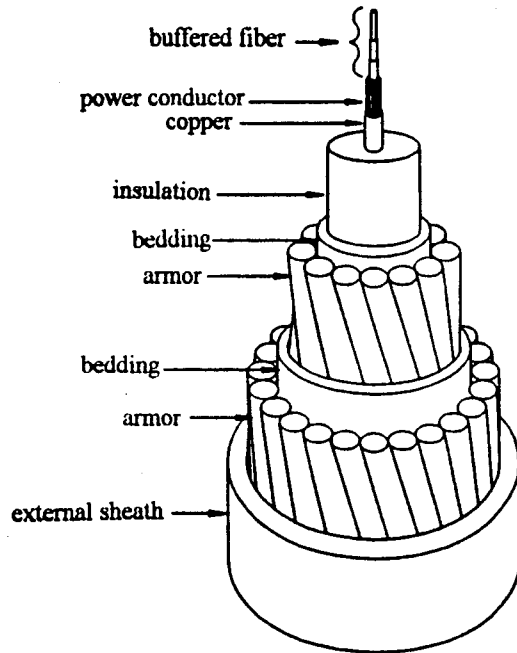

Heavy Armor Trunk

Figure 2-2. Typical Fiber Optic Cables (NAVFAC P-990 1994).

As far as inspections are concerned, there is little difference between the conventional coaxial cables and the newer fiber optic cables. The internal conductor for each type of cable may be different, however. As seen in Figure 2-2, the optical fibers are encased in metal tubes or layers of wires. Since the electrical power conductors and mechanical strength components remain the same, the external properties of the fiber optic cables are almost identical to those of the coaxial cables. As described in NAVFAC manual P-990, fiber optic cables can, in general, be handled, installed, and stabilized using the same methods as coaxial cables.

## **2.2 Cable Stabilization**

As discussed earlier, underwater cables are subjected to a number of environmental hazards. When a cable is installed, it is initially stabilized to protect it from wave and current forces. A common technique for stabilizing cable through the surf zone and over rocky bottoms is to install "split-pipe" on the outside of the cable. Split-pipe is heavy, modular cast-iron, half-pipe sections as illustrated in Figure 2-3. Split pipe may also be used in conjunction with bolting the cable to the sea floor as shown in Figure 2-4. The application of steel rockbolts requires the use of sacrificial anodes.

Concrete is also used to stabilize cables. Precast concrete elements or sacks of concrete may be placed over the cable, or the concrete may be poured over the cable either in unconfined flow or using cast-in-place forms. Other methods of stabilizing cables

include using chain draped across the cable, burying the cable, or anchoring the cable to the sea floor using pin anchors or straps as shown in Figure 2-5.

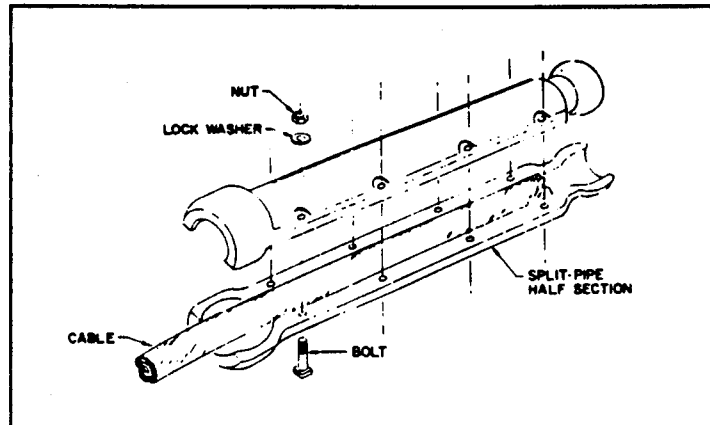

Figure 2-3. Split Pipe Stabilization (NAVFAC P-990 1978).

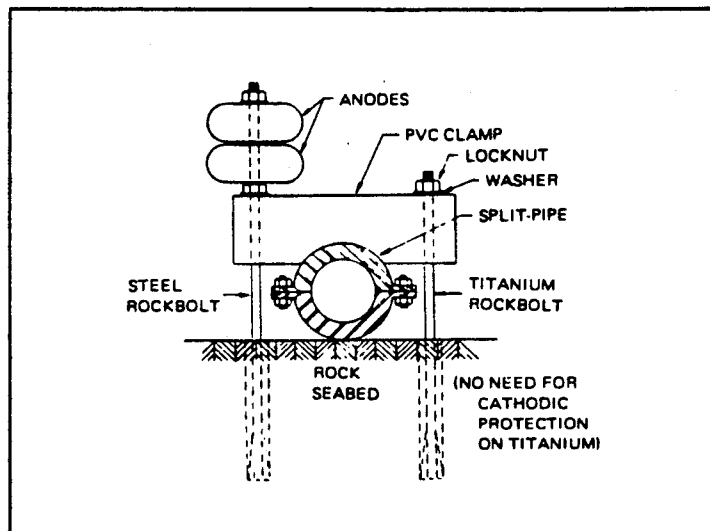

Figure 2-4. Rock Bolt Stabilization (NAVFAC P-990 1978).

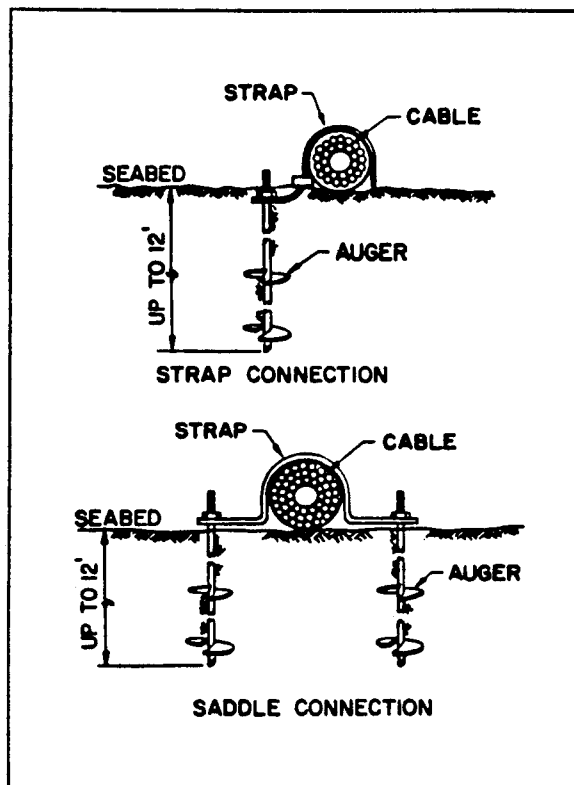

Figure 2-5. Pin Anchor and Strap Stabilization (NAVFAC P-990 1978).

### 2.3 Inspection Levels

The underwater cables of the Navy are inspected at different frequencies and at different levels depending on the mission of the cable, its location, and budgetary constraints. Until recently, the older, coaxial cables for tracking Soviet submarines were inspected at three year intervals. Now that the Cold War is over and the submarine tracking mission is less important, the frequency of inspection has been downgraded to a five year interval. On the other hand, range and communication cables which are used on

a daily basis are inspected on a much more frequent basis because cable down-time would have immediate impact.

The location of the cable also dictates the inspection frequency. For example, cables installed off the island of Kauai in Hawaii are inspected frequently since they are located in a very harsh environment. As pointed out in an inspection completion report (UCT Two 1984), constant movement of the sand by surf abrades the cables. Additionally, the cables have no natural protection during heavy storms, and the hard rock bottom does not allow cable burial for protection.

In general, the amount of inspection required for Navy underwater structures is categorized into one of three levels. These levels are described in Table 2-3. Due to the nature of cables, inspection at level III, which involves testing methods such as ultrasonic testing, magnetic particle testing, etc., is not accomplished. Underwater cables are inspected at levels I and II only.

#### **2.4 Cable Inspection Method**

The inspection method currently used by the UCTs to inspect underwater cables is a very basic and predominantly visual method. Since the UCTs are designed to be an independent, mobile inspection crew, equipment used for inspection and repair must be durable and portable. With a limited amount of equipment, the inspections instead become

TABLE 2-3  
INSPECTION LEVELS

LEVEL I - GENERAL VISUAL INSPECTION. This type of inspection does not involve cleaning of any structural elements and can therefore be conducted much more rapidly than the other types of inspection. The purpose of the Level I inspection is to confirm as-built structural plans, provide initial input for an inspection strategy, and detect obvious damage due to overstress, impacts, severe corrosion, or extensive biological attack.

LEVEL II - CLOSE-UP VISUAL INSPECTION. This type of inspection will generally involve prior or concurrent cleaning of part of the structural elements. The purpose of the Level II inspection is to detect surface damage that may be hidden by marine growth. Since the cleaning process will make this type of inspection more time consuming than the level one inspection, it will generally be restricted to the critical areas of the structure.

LEVEL III - NONDESTRUCTIVE TESTING. This type of inspection will be conducted to detect hidden or beginning damage. The training, cleaning and testing requirements will vary depending on the type of defect/damage that is anticipated and the type of inspection equipment used. In general, however, the equipment and test procedures will be more sophisticated and require considerably more experience and training than either the Level I or II inspection.

Source: NAVFAC P-990 1978

very labor intensive. Depending on weather conditions and the scope or level of inspection, the inspection of one nautical mile of cable takes on average one week to complete. A typical inspection log is shown below:

- Day 1 Travel to site. Make logistical arrangements (Logistical arrangements include: lodging for personnel, "courtesy calls" to discuss inspection plans with base personnel, arrangements for fuel, medical support, storage of equipment and gear, unpacking gear, checking equipment, setting up emergency-use hyperbaric chamber, etc.). Locate or establish survey bench marks.
- Day 2 If bench marks are easily established, set up transit stations, locate, survey, and inspect cable. Otherwise, continue clearing vegetation to establish line of sight between benchmarks.
- Days 3 to 4 If cable was easily located and inspected on day 2, pack up gear and depart. Otherwise, set up transit stations, locate, survey and inspect cable on day 3. Cable inspection usually takes 1-2 days depending on the level of inspection, the number of cables at a site, and the ease at which the cables are located.
- Days 5-6 Pack up gear. Write up inspection results. Inform base personnel of inspection results. Depart site.

Under normal conditions, the team works six days per week. Inspections are usually conducted between the months of April and September since weather conditions are more favorable during this period. The UCTs spend the other months of the year on training, equipment repairs and overhaul, and family time.

The cable inspection method is comprised of two main components:

- 1) Survey the cable location.
- 2) Determine the condition of the cable.

#### **2.4.1 Cable Survey**

The first portion of any cable inspection trip is a survey of cable location. The goal of the survey is to determine the position and depth of the cable at 100 foot intervals. Surveys are conducted using triangulation, with electronic distance measuring (EDM) equipment as a check. During the first day of an inspection trip, survey bench marks are located from previous inspections. Sufficient bench marks to survey the cable are established when the cable is installed. These bench marks are established such that all of the cable to a depth of 100 feet is visible from the bench marks. If the bench marks are no longer in good condition, or if the line of sight between bench marks is blocked by vegetation or new construction, then new bench marks are established. New bench marks are established with at least 3/4 mile separation, and with accessibility during different weather and tide conditions.

Permanent brass tags are attached to a cable either following its installation or during its first inspection. The brass tags are attached at 100 foot intervals, and are numbered in increasing order from the shore out to the sea. The brass tags enable divers to chart bottom topography by marking the depth at each 100 foot interval tag. The brass

tags also assist divers in referencing inspection deficiencies back to a specific location so that a damaged point may be efficiently returned to for repairs. If there is more than one cable at a particular site, a 1/4 inch hole is drilled into the corner of the second tag set to differentiate one set of tags from another. A second 1/4 inch hole would be drilled into the tag set for a third cable, and so on. A typical brass tag is illustrated in Figure 2-6.

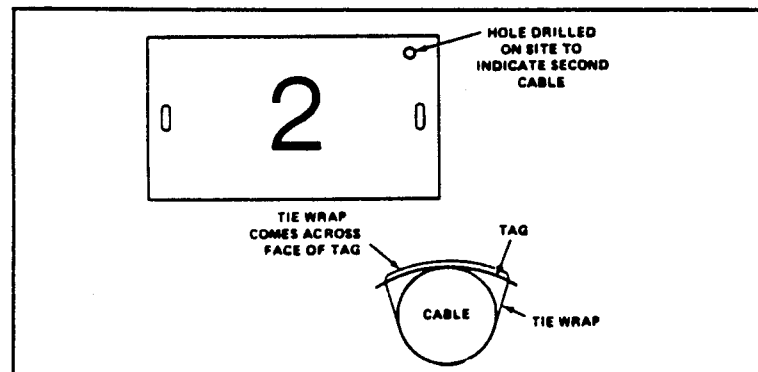

Figure 2-6. Typical Brass Tag Marker (NAVFAC P-990 1978).

The brass tags are usually installed using a “leap frog” method. Using a ten foot length of rope between them, divers move along the length of the cable in ten foot intervals, leap frogging past each other to the next 100 foot interval. After 100 feet of leap frogging, the divers join up to attach the tag. The leap frog method allows divers to stay within a safe distance at all times. The method is depicted in Figure 2-7.

In the majority of cable inspections, brass tags have already been installed, and the first step in the survey is to locate the cable. Depending on the bottom type at the site, the cable may be partially or completely buried, and is located either visually or with the help

of a magnetometer or cable tracking probe. The cable termination point on shore is not always easily identifiable, however, original construction drawings and previous inspection reports provide a starting point to begin the search for the cable.

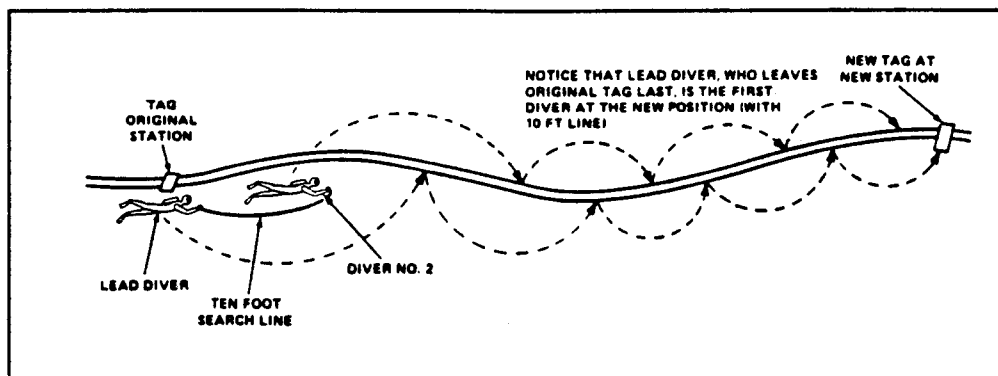

Figure 2-7. Leapfrog Method (NAVFAC P-990 1978).

The search for the cable may begin from the beach and progress outward, or the search may begin at the offshore connection point and proceed to the beach. In most cases, the search for the cable begins offshore. Transit/theodolite survey stations are set up on shore at the benchmarks. Using hand held radios, a diving operation boat is directed along a bearing from one transit station until the bearing from the other transit station indicates the boat is over the location where the cable was installed. At this point, a buoy marker is dropped as the starting point for the cable search.

Once the starting position is marked, two divers are sent down to begin looking for the cable at the marked buoy position. Depending on visibility and conditions, the cable may or may not be readily visible. If the cable is not located visually upon descent,

the divers search for the cable using a circling method. In the circling method, a line is anchored at the starting point on the sea bottom, and the divers begin circling the starting point using the line as a guide. Figure 2-8 illustrates the circling method.

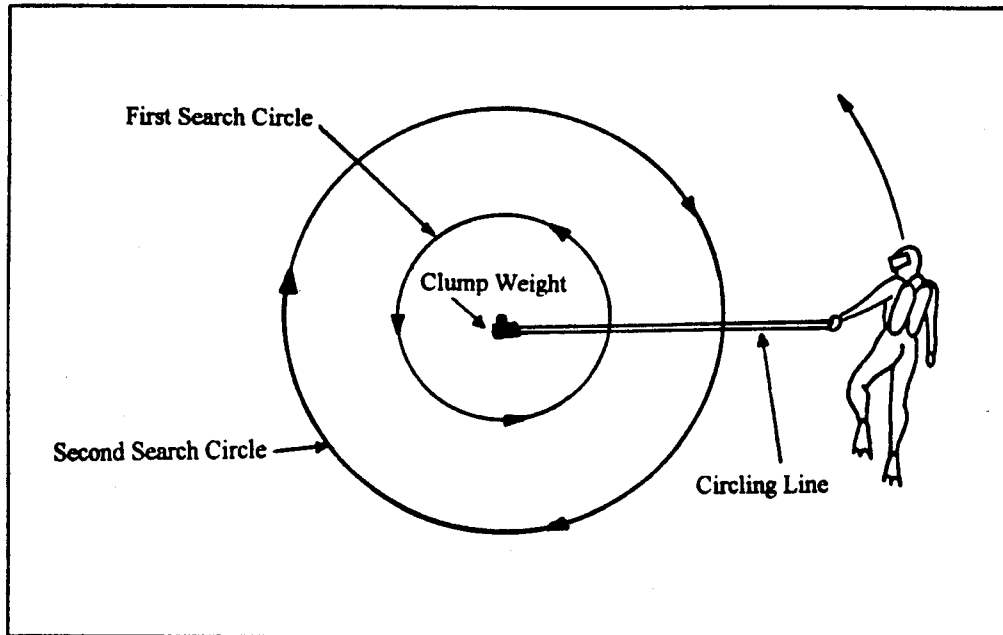

Figure 2-8. Circling Method of Visual Location.

If the cable is not located visually using the circling method, the cable may be located using a magnetometer or a diver-held cable tracking probe. The cable tracking probe is a tool developed especially for the UCTs. It is taken on cable inspection trips where difficulty in locating the cable is anticipated.

Once the cable is located by the divers, they then survey its path. The survey records the cable's position for future inspections. Charting the position and depth of the

cable also provides a way to note significant changes in bottom topography where the cable is located. The divers tow a float along with them as they move from one brass tag to another. At each tag, the divers note the water depth, and give a prearranged signal, such as four tugs on the float, to the crew on the boat. The crew on the boat then radios to the survey crew to mark the location of the float. As a check, the boat crew also holds up a reflective target so that the pulse range EDM unit on shore can measure distance to the float. Once the survey crew reports it has the sight, the boat crew signals to the divers to proceed to the next brass tag location. Figure 2-9 portrays the survey method.

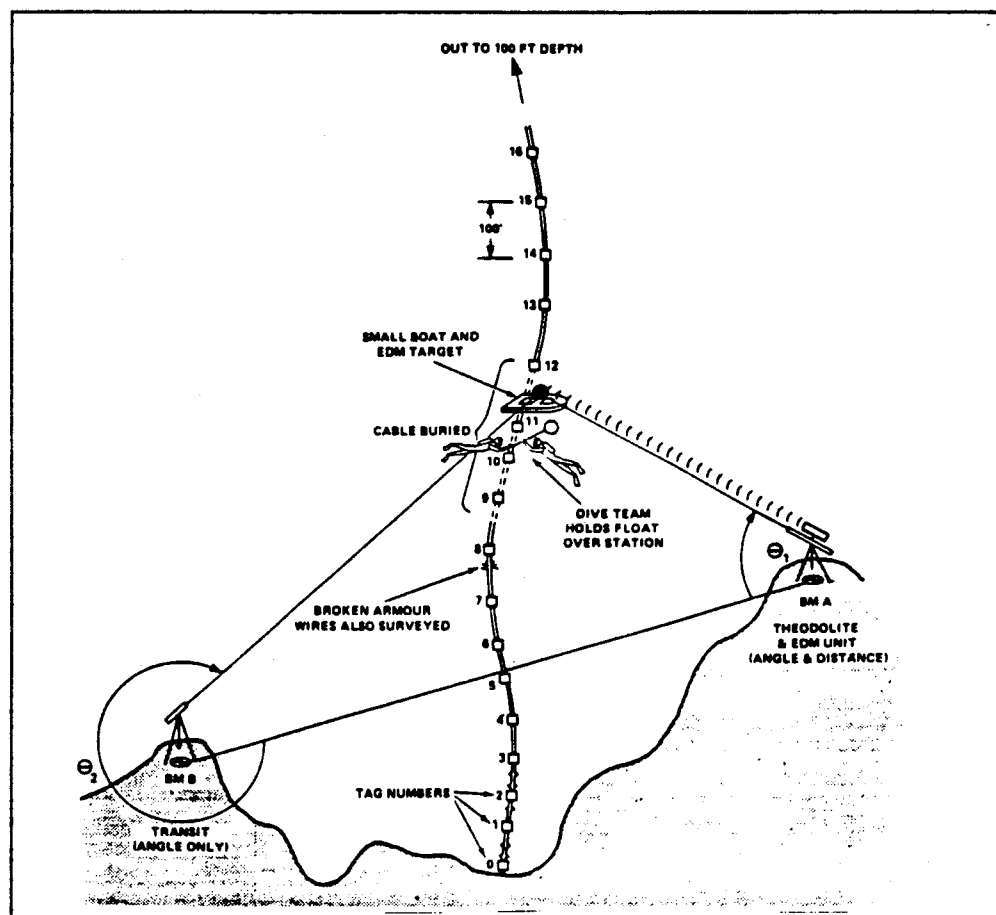

Figure 2-9. Triangulation Survey Method (NAVFAC P-990 1978).

## **2.4.2 Cable Inspection**

Before the cable is surveyed, its general condition is often assessed in a "swim-by" inspection. In a "swim-by," divers follow the path of the cable looking for obvious damage, large movements of the cable, and suspended sections in the cable. The swim-by provides a quick, general assessment of the condition of the cable. Divers then take a more detailed look at the cable and survey the locations of discrepancies using the same survey method described above. If the weather turns bad, precluding a closer look at the cable, the swim-by would have at least provided knowledge as to the manpower required for future repairs, or whether repairs or stabilization of the cable is required immediately. The different types of damage encountered are summarized in Table 2-4. Depending on the type of damage, measurements and photographs of the discrepancies are required. Table 2-5 summarizes instances in which damage to the cable must be documented by measurements and photographs.

## **2.5 Inspection Equipment**

As previously mentioned, the UCTs do not use large or complex equipment during inspection trips. The inspection team is designed to be a very mobile unit which can move efficiently and quickly from one inspection site to another. Equipment used by the team is described in the following sections.

TABLE 2-4

## MATRIX OF TYPES OF CABLE DAMAGE

Cable	Abrasion Protection System	Cathodic Protection System	Environment	Junctions Terminations of Cables	Immobilization System
Extensive damage to outer coating <sup>a</sup>	Deterioration of abrasion protection material	Missing or damaged anodes	Evidence of major wave action	Termination of cable stopper	Damaged or missing rockbolts or U-rods
Deterioration of armor wires <sup>a</sup>	Loose nuts or bolts	Overall reduction of size	Presence of natural or man-made debris	Condition of termination	Long spans without fasteners
Broken armor wires <sup>a</sup>	Missing nuts and bolts	Pitting of anode	Abrupt change in amount of marine growth in cable area	Damage to wire or out near termination or junction	Deterioration of clump anchors or fasteners
Evidence of non-wave induced loads	Evidence of non-wave induced load	Poor contact of anodes	Erosion or Accretion of sediment along cable	Sharp bends, kinks	Movement of anchor
Amount of marine growth	Missing or separated sections	Condition of "jumpers"	Evidence of local fishing		Movement of cable between fasteners
Large deviation from expected track of cable	Amount of marine growth	Inorganic fouling of anode	Evidence of seismic action		Loose fasteners
Kinking or birdcaged armor <sup>a</sup>	The end of the split pipe protection <sup>a</sup>		Presence of ice tracks		Uncovering of trenches
Protruding cable core <sup>a</sup>					Missing or bent fasteners
Buried cable <sup>a</sup>					Missing concrete or rock overburden on trenches
Sharp bends <sup>a</sup>					
Broken cable <sup>a</sup>					
Suspensions <sup>a</sup>					

Source: NAVFAC P-990 1978

<sup>a</sup> Exact position should be surveyed.

TABLE 2-5

DOCUMENTATION OF DAMAGE TO CABLES

Discrepancy	Tolerance	Measurement to be taken	Illustrations	Photo Required
Broken Armor Wires	0	Number of wires	NA	Yes
Abrasion of a. Cable b. Split Pipe c. Rock	+5% +5% +5%	Circumference Length Width Length	<p>a. </p> <p>b. </p> <p>c. NA</p>	Yes
Corrosion	NA	NA	NA	Yes
Bends/ Kinks	+5%	Diameter or Angle subtended		Yes
Missing/ loose split pipe	0	Number of sections loose	NA	Yes as appropriate
Missing/ loose nuts	+5%	Number of bolts		Yes as appropriate
Birdcaged armor wire	+5%	Circumference Length		Yes
Suspension	+5%	Length of span Height Height off bottom		Yes

Source: NAVFAC P-990 1978

### **2.5.1 Survey Equipment**

The cable survey is accomplished using standard survey equipment. The survey method uses triangulation to mark the cable position. The angle from each bench mark to the cable location is measured using a theodolite. Theodolites are tri-pod mounted optical devices which measure precise vertical and horizontal angles between points. The theodolites are modified for mounting EDMs on top to measure distance. Electronic distance measuring (EDM) devices measure distance by emitting an infrared light pulse to a prism target, which is reflected back to the instrument and converted into an electrical signal. The amount of time for the light pulse to travel to the prism and back is proportional to the distance between the transmitter and the target.

### **2.5.2 Diver Equipment**

The divers of the inspection teams operate in relatively shallow water. Since 100 feet is the maximum depth for cable inspections, divers can use Self Contained Underwater Breathing Apparatus (scuba) systems instead of surface supplied diving systems or saturation diving. Scuba allows the divers more mobility and freedom for work than other diving systems, and is the most advantageous system for shallow water. The scuba tanks used by Navy divers are twin 80 cubic foot tanks. These tanks provide for 1.5 to 2 hours of diving, depending on the temperature and how hard the diver is working.

Individual pieces of diver equipment such as masks, suits, and air regulators vary depending on conditions at the dive site. Clothing ranges from the most protective dry suits for arctic diving, to shorts and T-shirt for tropical locations. In most locations, a hard helmet is worn with a 3/8 inch neoprene wetsuit. In some instances, an AGA DIVATOR II mask may be used in place of the hard helmet. The AGA is a commercially available mask designed with integrated air and communications built into the mask. The communication device provides instant feedback and information to crew members on the diving operation boat.

### **2.5.3 Surface Vessels**

The diving operation boat used for most diving inspection is either a small, rubber Zodiac boat, or a "LARC V" amphibious craft. The LARC V craft, illustrated in Figure 2-10, is particularly useful because it is designed to drive straight from the beach into the water.

### **2.5.4 Underwater Tools**

The UCTs are equipped with a number of tools that are available commercially. The inspection teams also have a number of tools designed specifically for them by the Naval Facilities Engineering Service Center (formally the Naval Civil Engineering Laboratory or NCEL). Diving equipment and tools used by Navy divers, even though

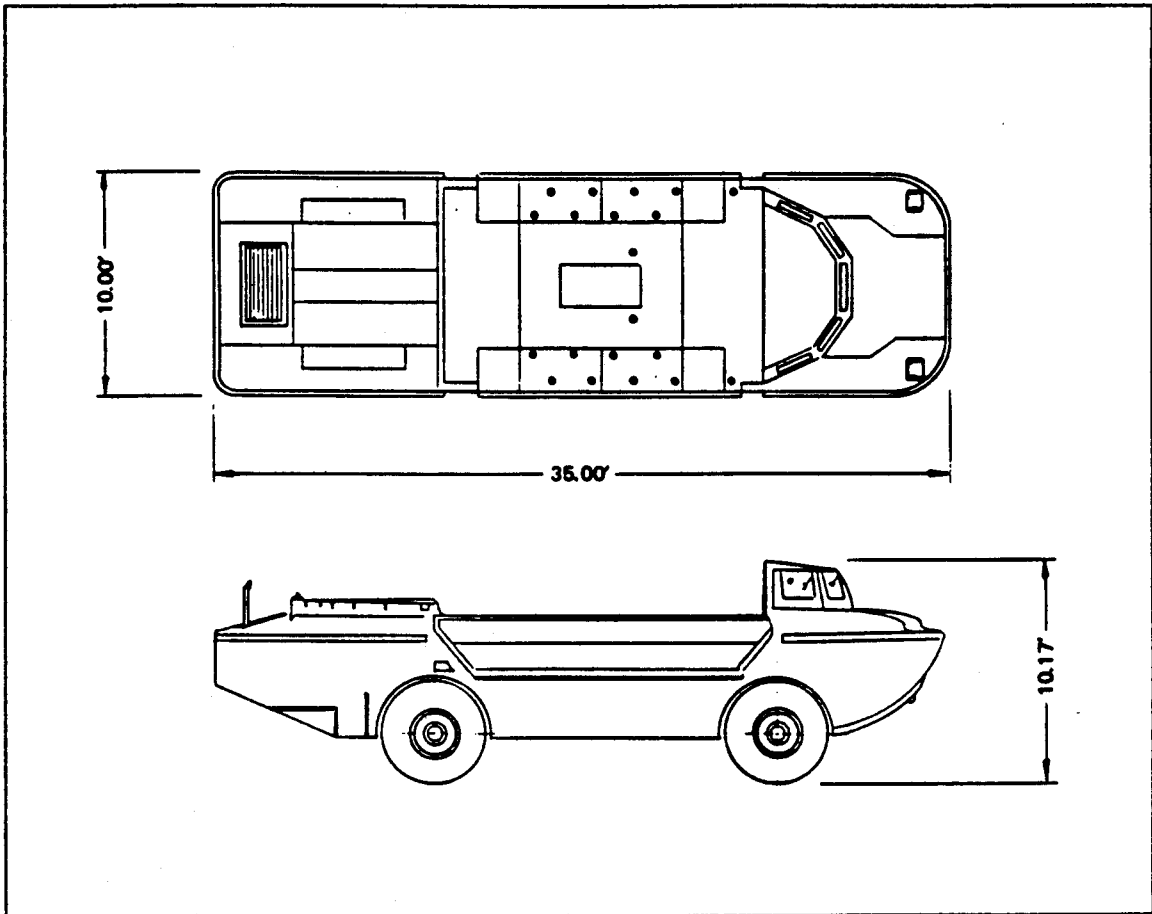

Figure 2-10. LARC V Vessel (NAVFAC P-990 1978).

available on the commercial market, must still undergo extensive safety testing at a Navy laboratory or research center before the equipment is authorized for Navy use. The Naval Sea Systems Command publishes a list of all diving equipment which is authorized for Navy use. Equipment not on this list may not be used by the UCTs.

Critical pieces of equipment for underwater inspections are cable locating tools. As described previously, the first attempt at locating a cable is done visually where divers are sent down to look for the cable in its last known surveyed position. If these visual

attempts at locating the cable are unsuccessful, there are two tools available to the divers to assist in locating the cable. The first tool, illustrated in figure 2-11, is a metal locator which may be used for locating buried pipes, chains, and armored cables. This instrument is a commercially available Forster Ferex (Model 4.021) magnetometer, manufactured by Institute Dr. Forster, and modified for UCT use with waterproof housings and accessories. There are two operational modes of the magnetometer: either carried by the diver, or towed from a surface vessel. The probe contains two magnetometer flux gates which sense the earth's magnetic field and can detect a disruption caused by a ferrous object such as an armored cable. The extension tubes provide separation between the diver and the probe, which minimizes interference from the diver's tanks. The metal locator weighs about 40 pounds in water and is approximately 12 feet in length (Holt 1994).

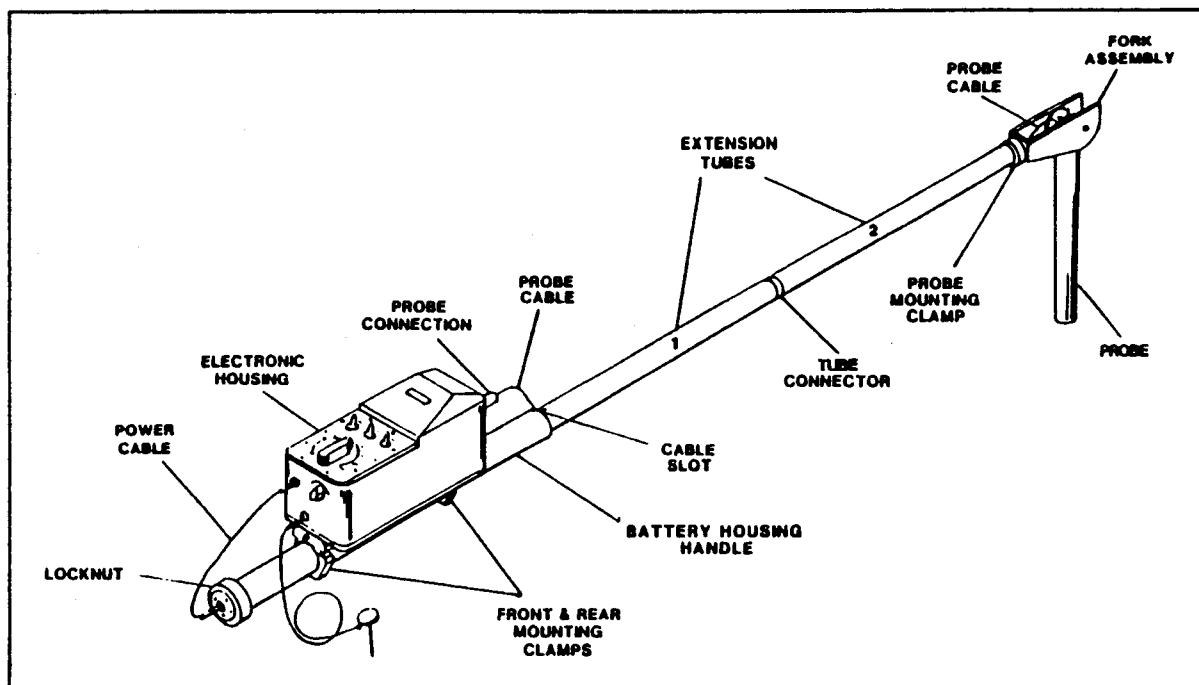

Figure 2-11. Metal Locator Tool (Thomson 1993).

Another tool which is used to locate buried cables is a cable tracking system developed for UCT use. This system has two main components: a diver-held electronic probe, and a signal injector. The system operates by running a current through the buried, underwater cable to impress a magnetic field onto the cable. This magnetic field is then detected by the diver-held electronic probe. The probe can detect a 25 to 1000 Hertz magnetic field. The magnetic field is impressed onto the cable in one of two ways: on land or in the water. If the shore end of the cable is accessible, a "dry" signal injector may be used to apply a current to the cable. When the cable is not accessible from the shore, a "wet" signal injector must be used. The wet signal injector is also used when detecting a cable past a cable fault (NAVFAC 1978).

The diver propulsion vehicle (DPV) is an underwater vehicle used for cable inspections and other tasks. The vehicle is a small (approximately 4 feet in length), propulsion device which pulls a diver through the water. The diver controls the vehicle through handles located on the side. Figure 2-12 shows a sketch of a diver on a DPV.

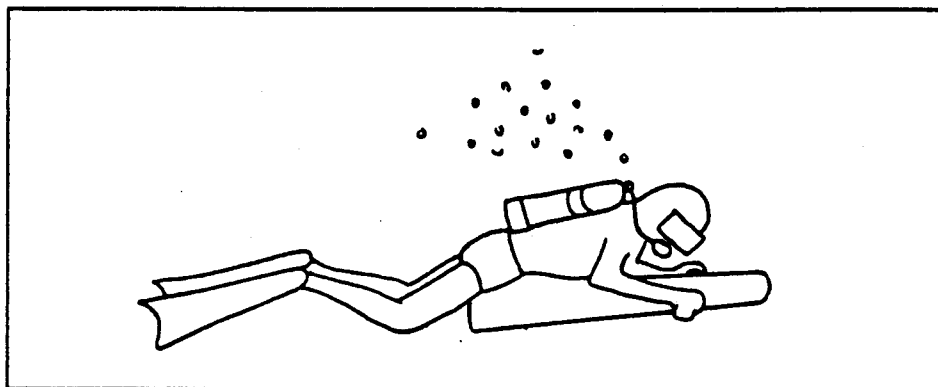

Figure 2-12. Diver Propulsion Vehicle.

Other tools which are useful for cable inspections are underwater cameras and video equipment. Underwater photographs and video are important in recording observations and the general condition of the cable. Current video equipment available to the UCTs does not allow "real time" video. The video footage must be taken during the inspection and played at a later time. Within the next year, the inspection teams will have available to them the Seahawk Integrated Colour TV System manufactured by Osprey Electronics. The Seahawk is tethered to the surface, which requires special handling, however, the camera allows the image to be seen on the surface as it is videotaped. The Seahawk can also operate in low visibility conditions.

## **2.6 Inspection Recording Procedures**

Reporting requirements for cable inspections are listed in Tables 2-4 and 2-5. Table 2-4 lists all the cable discrepancies in which divers should observe and record the condition of the cable. It also specifies whether or not a survey is required. Table 2-5 summarizes the measurements which are required for certain discrepancies. The discrepancy information is recorded by divers on a slate as it is observed. This information is then transferred to a log by the dive supervisor after the inspection. When an AGA mask with communication capability is used, the inspection observations can be relayed from the divers to the dive supervisor topside, and recorded directly in the log.

Photographs and video are an excellent method of documentation because they allow non-diving personnel to view the condition of the cable, and they provide a permanent record of the condition of the cable.

## **2.7 Personnel and Training Required for Inspections**

An inspection crew typically is comprised of seven to twelve divers of various levels of experience and background. The minimum dive crew on an underwater inspection consists of five members: two divers in the water, one standby diver, a boat operator and a supervisor. The divers on the inspection team generally have between five to twenty five years of experience in the Navy. The area of expertise of each diver on the inspection team will fall into one of the following seven categories:

- Electrician
- Utilities
- Builder
- Mechanic
- Equipment Operator
- Steelworker
- Engineering Aide

Immediately following basic military training, or "boot camp," each recruit is sent to a Navy "Seabee" school for training in one of the above specialties. The length of the training depends on the area of expertise, but is typically several months in duration. Following this training, the member, or "seabee," is sent to one of eight Navy Mobile

Construction Battalions for three to four years. The battalions do construction work of all kinds in locations around the world. At some point before turning thirty years of age, the seabee decides to join an Underwater Construction Team.

The first step to joining one of the inspection teams is completing six months of training at a Navy basic dive school. No previous dive training is required before attending the Navy dive school. The school provides rigorous training and physical conditioning while covering the elementary principles of diving, dive equipment, and diving physiology. After becoming a diver, the seabee learns the basics about underwater construction in a nine week school. This school covers training in underwater work methods such as welding and cutting, how to pump concrete underwater, small craft operation, surveying, use of basic tools, etc. With this level of training, the diver reports to one of the two UCTs for duty.

Once at a UCT, the divers continue to receive both formal and informal training on underwater work procedures. Training and certification is required before operating certain tools such as the Diver Propulsion Vehicle. Other tools, such as the underwater cable tracking system, require familiarization training, but no formal certification. Most training is conducted during the months of October to March when the Teams are not deployed to construction or inspection sites. The divers are expected to continually learn more and take on more responsibility in their duties. After two to three years of duty at a UCT, the diver is sent back for 8 more weeks of diver training. This schooling is meant to

train divers to be supervisors. Supervisory training is followed up by advanced training in underwater construction techniques. Topics covered include project planning, estimating, tasking, and other supervisory duties.

**CHAPTER 3**  
**OPPORTUNITIES FOR IMPROVEMENT IN**  
**CURRENT CABLE INSPECTION METHODS**

The current method of cable inspection used by Navy Underwater Construction Teams is generally an effective method of inspection. The condition of underwater cables can be assessed in a reasonable amount of time and for a reasonable cost. In terms of reliability, as long as the underwater cables can be found, their condition can be assessed. In addition, the safety record for the Navy Teams is very good. In the twenty five year history of the Teams, injuries or fatalities have been very rare. While the current cable inspection method is practical and effectual, interviews with Navy divers have revealed several problems with cable inspections as discussed below.

**3.1 Cable Location and Surveying Difficulties**

The most time consuming and difficult portion of any cable inspection is locating and surveying the cable. Cables may be partially or completely buried at the site, depending on the bottom type. In some instances, cables are buried during installation as a stabilization and protection measure. In other cases, cables bury themselves. The older

and heavier coaxial cables can undergo self-burial to a depth of ten feet in a relatively soft bottom (Holt 1994). Locating the cables can be a time consuming process for several reasons:

- a. Survey bench marks overgrown or not easily located
- b. Visual search patterns methodical and slow
- c. Tools for cable location not universally effective

Before beginning the search for the cable, time must be spent in setting up survey equipment to mark the starting point for the search. A review of inspection completion reports indicates that locating or establishing benchmarks and setting up survey equipment takes anywhere from half a working day to several working days to complete. With inspections at five year intervals at some locations, original benchmarks may either not be found, or the line of sight between bench marks may not be visible due to heavy vegetation growth. In one third of the inspection reports reviewed for this report, divers spent time cutting down overgrown vegetation to establish line of sight between benchmarks. During a 1991 cable inspection off the island of Guam, overgrown vegetation necessitated an entire day of underbrush cutting and removal to be able to sight the entire cable track (UCT Two 1991).

Once the starting point for the cable search is marked using onshore survey equipment, the first attempt at locating the cable using the circling method may be lengthy and ineffective. As discussed earlier, the circling method utilizes a guideline attached to

the starting point by a clump weight. This method establishes a logical search pattern to cover the entire sea bottom in the vicinity of the starting point. During the latest cable inspection at Coos Bay, Oregon in 1991, diving operations began at 7 a.m. with attempts to locate the cable using a 100 foot circling line. At the close of diving operations ten hours later, divers still had not found the cable (UCT Two 1991).

While the visual circling method of locating a cable can be time consuming and unsuccessful, tools designed specifically for cable location may also prove equally ineffective. If a visual search in the last known area of the cable is not effective, the next attempt at cable location is with either a "cable tracker" or a magnetometer. In some locations where the sea bottom is sandy and it is highly probable that the cable is completely buried, or where the cable was buried during installation, a cable tracker or magnetometer is used from the beginning of the search instead of the visual circling method.

The magnetometer and cable tracker were described briefly in Chapter 2. Overall, the Teams have experienced some success in employing these two tools to locate cables. However, the tools are not without problems. The main difficulty with the current metal locator tool authorized for UCT use is that it cannot detect cables which are buried more than 2-3 feet in the seabed. Additionally, the tool is not very portable. With a length of approximately 12 feet and weight of 35 pounds in air (or 3 lbs in water), the metal locator is difficult to maneuver. Its bulky size makes operation cumbersome and very slow. In

addition, an elemental problem with magnetometers is that they respond to any magnetic anomaly in an area. As a result, time can be lost chasing false readings (NAVFAC P-990 1978).

The cable tracker is a tool designed specifically with Navy cables in mind. Based on interviews with several divers, the cable tracker has some successful applications, however, it does not solve all problems in locating cables. As discussed earlier, the cable tracker operates by tracking the magnetic field created by injecting a signal onto the cable. If a signal can be injected onto the cable, and the cable does not have a significant amount of cover, then the cable can be located using the diver held cable tracking probe. While the probe is designed to locate cables which may be buried, in actual practice, the signal becomes too weak for the probe to pick up if the cable has more than three to six inches of cover.

The cable tracker is also ineffective if a signal cannot be injected onto the cable. If shore based access to the cable is possible, a 25 hertz or 1,024 hertz signal, or tracking tone, may be impressed onto the cable by hard wiring a shore based transmitter to the cable. The other way to inject a current onto the cable is to clamp a diver-deployed coil to the cable underwater. If no portion of the cable can be located underwater, the coil may not be applied to inject a current. Obviously, if a current cannot be injected onto the cable, then there is no magnetic field to track. Therefore if shore-based access to the cable

is not available, and a portion of the cable cannot be found underwater, then the cable cannot be located using the cable tracker.

Another drawback to the cable tracker is that it is not a simple system. The diver-held probe is an easily carried instrument which weighs only 2 pounds in water, yet there are many other pieces to the system. For example, to inject a signal underwater requires a battery pack, an amplifier/electronics canister, an injector coil, and a battery charger. These pieces weigh almost 200 pounds in air or 65 pounds in water. With the exception of the battery charger, these pieces are lowered to the sea floor and linked electrically with underwater mateable cables and connectors. The coil is clamped around the cable while a 1,024 hertz signal is applied by the amplifier canister. The four hour battery pack supplies DC power to drive the amplifier. Each piece of equipment is fragile and requires much care to operate and maintain. A frequent problem with the shore based transmitter is in properly grounding it. The shore based signal transmitter must be properly grounded so that current does not travel down one conductor of the cable and back through another conductor in the same cable, thus resulting in a net cancellation of the magnetic fields produced by the current flow.

Clearly, a faster, more reliable means of locating the cables would significantly reduce the amount of time required for each cable inspection. Currently, much time is spent clearing vegetation in order to determine the initial "starting point" to begin looking for the cable. Much time is also spent fruitlessly trying to find cables which have self-

buried greater than 3 feet. Getting to the cable in a quicker, more efficient manner would allow divers to spend more time actually inspecting, and not searching for, the cable.

### **3.2 Human Limitations**

While the UCT divers do employ some tools in performing a cable inspection, the main "tools" used during the inspection are the divers themselves. As with any method, every advantage in a process is usually accompanied by a disadvantage. Since cable inspections are predominantly visual and labor intensive, there is little reliance on complicated machinery or equipment which can break down at critical moments. By being labor intensive, however, each inspection involves many dives and hours in the water. Decreasing the amount of man-hours for an inspection would obviously decrease the cost of performing an inspection.

Decreasing the amount of hours of diving also decreases the danger to the operation. While the track record of the Teams has shown their operation to be a safe one, whenever divers are in the water, there exists a danger to personnel. The good safety track record of the UCTs can be attributed to stringent guidelines in diving practices, and to rigorous screening and training received by divers. It is very important to have a safe operation, but safety does come at a price: training costs, duration of inspection, increased manpower to limit the number of dives per day, etc.

On a scale of difficulty, cable inspections are considered relatively simple and straightforward compared to the many inspection, construction, and repair projects undertaken by the UCTs. When asked what is the most difficult part of a cable inspection, a common reply is simply "boredom." Inspecting thousands of lineal feet of cable can become a monotonous chore. In terms of mistakes, boredom is not an optimum state in which to operate. If a chore is considered boring, there is a certain amount of inattention to the task at hand which can lead to errors. Human error has been shown to be the source of the majority of high consequence accidents in the marine industry (Bea 1994b). Figure 3-1 depicts the optimal level of human performance in terms of time pressure. An optimal level of performance occurs when people are not overtasked or undertasked. Therefore, operating in a state of boredom is not optimal in terms of performance and errors.

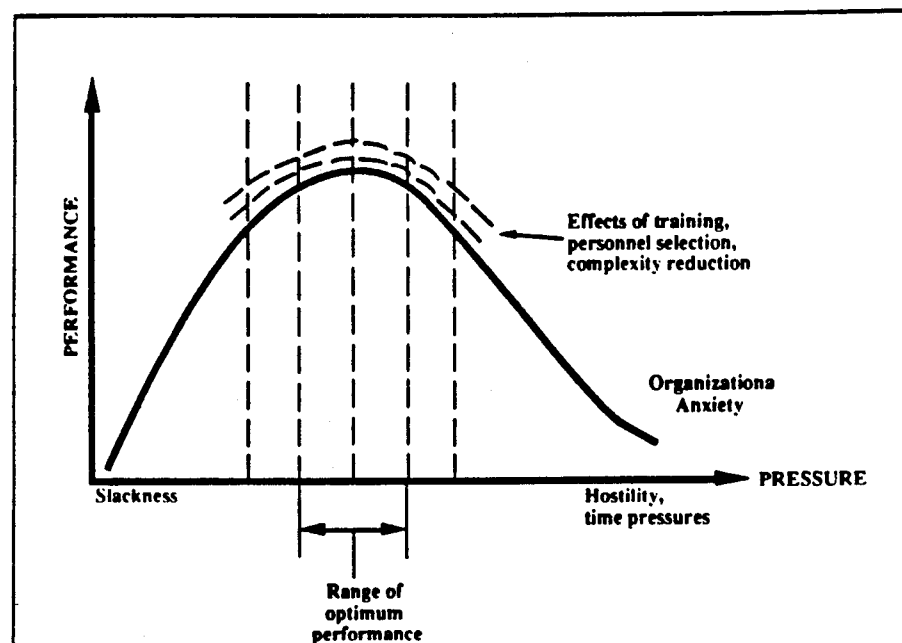

Figure 3-1. Human Performance Function. (Bea 1994b).

Another human limitation of cable inspections, or any underwater inspection for that matter, concerns the age of divers. Diving is an age limited profession. Divers must be in excellent condition not only to get the job done, but also to protect themselves from physiological problems associated with diving such as decompression sickness. Age has been shown to be a factor in decompression sickness, and older divers must reduce their number of hours in the water (Gross 1994). As a result, the most experienced divers in the Teams end up spending the least amount of time in the water doing the inspections.

One limitation in efforts to record inspections is a lack of qualified and trained photographers. Pictures taken of underwater objects by novice photographers are usually of poor quality due to ignorance of lighting and other factors. For higher quality results, each UCT has a professional photographer as part of their Team. This photographer receives dive training, and can accompany divers during an inspection. Pictures are an important way to record the results of inspection discrepancies. Pictures are also important in relating the cable condition to people who are not able to see the condition of the underwater cables firsthand. Since the Teams have many projects underway at any given time and only one photographer/diver, quality pictures are available for only the most critical projects.

The primary means of dealing with inspection problems imposed by human limitations is to reduce the amount of time divers spend in the water. Decreasing the amount of time in the water equates to an inherently safer operation, which may also be

less expensive. For that amount of time divers must be in the water, adjusting the tasking could also increase inspection efficiency and safety by maintaining a high level of productivity through appropriate workload.

### **3.3 Weather Difficulties**

Other difficulties encountered during inspections are caused by weather limitations. The majority of cable inspections are performed from spring to early fall so that weather will not impact the operations. From time to time, inspection efforts must be postponed due to inclement weather. Rough seas or swells preclude use of the electronic distance measuring device since the reflective prism held topside is not stable, but instead rises up and down with the waves. In rough seas, the time for inspection increases, as well as the amount of danger to divers. If the cable is being photographed, rough weather also can diminish the quality of the pictures.

### **3.4 Summary of Opportunities for Improvement**

In any cable inspection, the primary objectives are to assess and document the condition of the underwater cables using a minimum amount of resources, with minimum risk to divers. In light of the difficulties discussed above with current inspection procedures, decreasing the cost of inspection while improving safety leads to the obvious

solution of divers spending less time in the water, and less time at the inspection site overall.

By analyzing the current inspection process, it is seen that time can potentially be saved in several areas of the inspection process. First, inspection time could be significantly reduced by decreasing the amount of time it takes just to determine a "starting point" to begin looking for the cable. Having to clear vegetation interfering with line of sight between survey bench marks represents time better spent on the actual inspection itself. The main opportunity, however, for decreasing the amount of time for the inspection is through more effective cable location methods, particularly if the cable is buried several feet below the sea floor. From an inspection standpoint, if the cables are buried and no interruption of service has been noted, the condition of the cable can be assumed satisfactory. Nevertheless, given that in a severe storm, cables can be exposed, damaged, and re-buried, knowing the location of buried cables is still important if service later goes down and the cable must be located for repairs. Lastly, after the cable is located and surveyed, the cable inspection is an area where time could be potentially saved through more efficient methods.

## CHAPTER 4

### ASSESSMENT METHOD

#### 4.1 Evaluation Criteria

In analyzing new ways to improve the present inspection process, it is first necessary to establish a framework for evaluation. This report reviews current technology with the potential to be used in the marine environment for cable surveys or inspections. It represents a "first chop," or screening of potential technology. This screening is a preliminary qualitative assessment, and is beneficial in selecting the best options to pursue further. Determining whether new equipment or a new inspection practice is better or worse than the current practice can be difficult at first glance, because any proposed alternative will have both advantages and disadvantages. Therefore, the initial step in establishing a framework for evaluation is to identify specific criteria or factors which are important for an effective inspection system. Table 4-1 outlines important elements or criterion for evaluating proposed inspection equipment or methods. Inspection methods should show high performance and efficiency, as well as being durable, and compatible with available resources and personnel. Each of these criteria are explained below.

TABLE 4-1  
EVALUATION CRITERIA

PERFORMANCE	EFFICIENCY	DURABILITY/ FLEXIBILITY	COMPATIBLE WITH PERSONNEL
Reliability of Technology  Quality of Results	Time  Cost	Durability  Affected by Weather  Dependence on Visibility	Manpower  Training  Safety  Portability  Ease of Use

**Performance.** This category refers to the dependability of the inspection equipment or methods.

- **Reliability of technology** - Is the technology new and untested, or has it been around for many years? Equipment malfunctions during an inspection can result in much wasted time with divers standing by.

- **Quality of results** - The performance of the inspection method or equipment also relates to the quality of the inspection results or the amount of confidence in the results. Does the inspection method accurately assess the condition of the cables? For example, visual inspection with the divers' eyes provides first hand, reliable results, but other inspection methods may require interpretation of the results.

**Efficiency**. Efficiency is the ability to accomplish a job with a minimum expenditure of time and money.

- **Time required** - This is an important criteria because the amount of time it takes to conduct a survey or an inspection relates directly to efficiency, cost, and safety.

- **Cost** - A prohibitive cost can prevent an inspection method from being considered to be feasible.

**Durability/ Flexibility**. This category is an essential evaluation criteria due to the harsh nature of the marine environment.

- **Durability** - Durability refers mainly to equipment and is a measure of its ruggedness and ability to operate safely over extended periods in the ocean.

- **Affected by weather** - Some inspection methods are affected more than other methods by inclement weather. Other things equal, the best inspection method is one which is not affected by weather.

- **Dependence on visibility** - Visibility can be decreased by factors such as general turbidity in the water, movement near the seafloor which stirs sediment into suspension, or heavy concentrations of plankton which accumulate at the thermocline and absorb light. Inspection methods which are not dependent on visibility may be an improvement over those methods which rely on sufficient visibility.

**Compatible with personnel.** This category encompasses criteria regarding the capabilities and limitations of the personnel conducting the inspections. Compatibility evaluates how adaptable the technology is for use by the UCTs.

- **Manpower** - The resources for conducting an inspection are limited. The viability of a proposed inspection alternative therefore depends on the manpower required for the new method. This is an important criteria for evaluation because the manpower required for an inspection method also affects the cost and safety of an inspection.

- **Training** - This factor concerns the amount of training necessary to be able to use a particular inspection method or piece of inspection equipment. Clearly, the amount of training required affects the resources needed for the proposed alternative.

- **Safety** - Underwater work takes place in an environment that is hostile and foreign to man. As such, there is little margin for error in underwater work. The conditions that exist underwater - high pressure, turbidity and restricted visibility, buoyancy, high thermal conductivity and absorption - are not necessarily limitations, rather basic conditions of the job. These conditions do not preclude underwater work, but they do require additional planning and expertise to ensure safety in the operation. It is important that any inspection method consider the safety of personnel. One note should be made regarding safety. Safety does not imply that there is no risk; whenever an inspection is conducted, there are elements of risk. Safety is merely a judgment about the acceptance of a certain level of risk.

- **Portability** - Since a requirement for the Teams is to be mobile, the portability of inspection equipment becomes an important criterion.

- **Ease of use** - This evaluation factor is self-explanatory and refers to use by current UCT Teams.

## **4.2 Assessment Process**

The assessment involved a somewhat iterative process of obtaining information on prospective technologies, reviewing how the technology could be used for cable surveys or inspections, comparing it with current practice, and then gathering more information on the technology. Besides books and periodicals, much of the information was obtained by requesting product literature from manufacturers, and from conversations with product representatives.

## **4.3 Assessment Format**

The evaluation criteria listed in Section 4.1 are somewhat general, which allows them to be the basis for evaluating cable surveying, location, or inspection methods. Evaluating each alternative against a list of criteria provides a systematic way of looking at the different possibilities for cable inspection. The assessment itself is accomplished in a qualitative manner as shown in Table 4-2.

Each inspection alternative is evaluated as either better (+), worse (-), or the same as the current inspection process. The abbreviation NEI is also used to evaluate criteria

TABLE 4-2  
ASSESSMENT FORMAT

Criteria	Technology A	Technology B	Technology C
Criterion 1	+	+	same
Criterion 2	-	+	-
Criterion 3	same	-	+

where there is Not Enough Information available to make a judgment. Evaluating each proposal in a more exact manner, such as with a number scale, would be meaningless since there is not enough information for such a precise judgment about each inspection method. Since each criterion is not equally weighted (for example, the *quality of results* achieved may be more important than *ease of use*), the plus and minus signs cannot simply be added up at the bottom of each column. The table is beneficial, nonetheless, in pointing out which technologies should be abandoned and which should be evaluated further.

#### 4.4 Datum for Comparison

The datum for evaluation is logically the current method of inspection. Chapter 2 described current inspection practices, and Chapter 3 further discussed the current

practices in light of difficulties experienced during inspection. The current inspection practice will again be described here as it relates to the evaluation criteria.

**Reliability of Technology.** Depending on the alternative being evaluated, technology can refer to several different things. For cable surveying, technology refers to the theodolite and transit survey equipment. This equipment is simple and basic technology which has been used reliably for many years. For visual cable location or inspection, technology refers to the diver's eyes and to the basic dive equipment. The information we see with our eyes is first hand, reliable information. Additionally, basic dive equipment such as wetsuits, SCUBA tanks, and regulators, is very reliable. Crude forms of underwater breathing devices were developed in the early 1800s, with more modern versions available following World War II. The commercial SCUBA used today has therefore been improving for many decades. Furthermore, since a diver's life depends on the gear, thorough testing of the technology has been required before allowing it on the market. Overall, the current technology used by the UCTs is reliable with the exception of the cable tracker.

**Quality of results.** For the most part, the quality of the results achieved with current inspection practices is very good because current methods are predominantly visual. Visual methods offer many advantages ( Bayliss, Short, and Bax 1988):

- (a) The eyes can focus from few inches to infinity and give a wide-angle view of the area, which gives an overall perspective view.

- (b) Different textures can be viewed and interpreted.
- (c) Viewing is by stereoscopic vision, so depth is seen.
- (d) Natural color is seen without any artificial bias being introduced
- (e) The visual information is immediately interpreted by the brain.
- (f) The actual item, and not a two-dimensional picture of the item is inspected.
- (g) A verbal report can be given concurrently with the inspection.
- (h) No other equipment is required apart from a light source.

**Time.** The amount of time it takes to conduct an inspection depends on the specific conditions at each site, however, a typical cable inspection usually takes from 3-6 days as described in the typical inspection log in Chapter 2.

**Cost.** Outfitting each diver costs approximately \$4,000. The Forster Ferex metal locator can be acquired for approximately \$10,000. The cable tracker from Western Instrument Corporation costs \$16,700, including the signal injection equipment. The cost of other equipment such as the diving vessel is not included here because all of the technologies which will be discussed, with the exception of radar, also require a vessel from which to operate. Personnel costs are considered under the manpower criterion. Thus, cost refers only to the cost of equipment.

**Durability.** The majority of current inspection equipment is highly durable. The cable locator tool is the least durable piece of equipment; the Teams have experienced some problems with individual parts breaking down.

**Affected by weather.** Sea state limitations depend to a large degree on the type and size of diving platform. Diving operations can be carried out in rougher seas when using the LARC V amphibious craft as opposed to conducting dive operations from a rubber, zodiac type boat. Entering or exiting the water becomes the most critical or dangerous part of the diving operation when the seas become rough. The degree of surface visibility is also important. For example, in low visibility conditions, a surfacing scuba diver may not be able to find the support craft, or could be in danger of being run down by surface traffic if in a busy area. UCT diving operations usually will not be conducted when conditions pass Sea State 3, which describes average wave heights ( $H_{sig}$ ) of 3.5 feet. This corresponds to a Beaufort Number of 4, or a moderate breeze of 11-16 knots. Figure 4-1 depicts the progressing sea states.

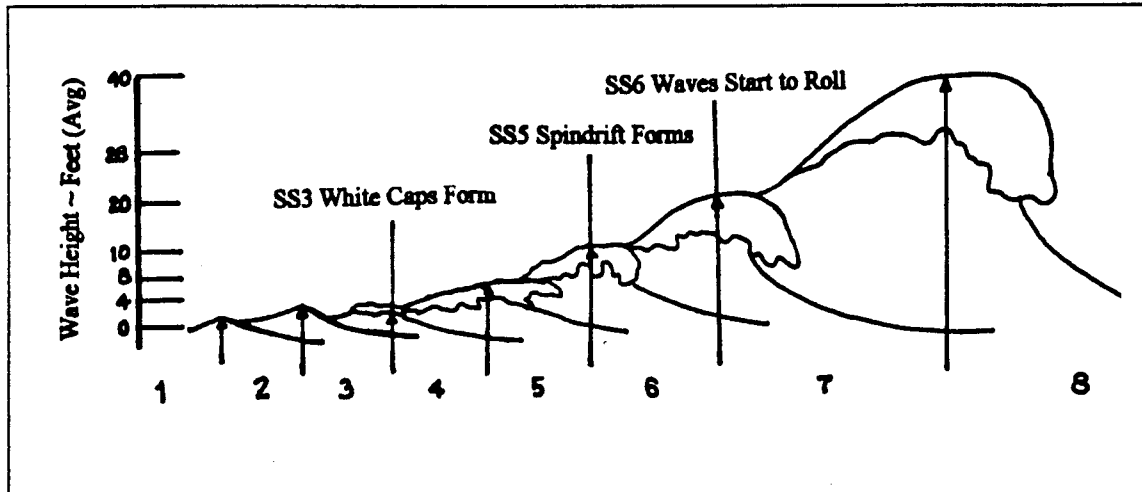

Figure 4-1. Sea States (National Oceanic and Atmospheric Administration Diving Manual 1991).

**Dependence on visibility.** Without doubt, current inspections are highly dependent on visibility since the methods are predominantly visual.

**Manpower.** As mentioned earlier, the minimum crew for inspections consists of five members: two divers in the water, one standby diver, a boat operator, and a supervisor. This is the minimum crew as dictated by safety considerations and Navy regulations. Combined with the two members required on shore when conducting a survey, the total number of personnel for an inspection is seven.

**Training.** The amount of training required for inspection members as outlined previously in Chapter 2 is substantial. Besides basic military training and training in one of the seven construction ratings, each inspection team member receives close to one year of training specifically in diving and underwater work methods.

**Safety.** The current method of inspection is very safe when compared to commercial diving operations. However, the current method is still dangerous because it involves a large amount of diving.

**Portability.** Besides basic dive gear scuba tanks, suits, and cable location tools, there is also support equipment such as an air compressor and compression chamber for emergencies. The largest piece of equipment is the LARC V amphibious craft which is 10 feet wide at the beam, and 35 feet in length. The amount of equipment which must be transported to each site depends on what is available locally at each site. For example, many sites which support other diving operations will have a compression chamber available, in which case it is not necessary for the UCTs to transport their own.

**Ease of use.** The majority of current inspection equipment, mainly dive gear, is essentially easy to use, with some exceptions as discussed earlier. The metal locating tool, not originally designed as a diver tool, is cumbersome to operate due primarily to its length, and the cable tracker is difficult to use when site conditions make it hard to inject a signal onto the cable.

#### **4.5 Assessment of Alternatives**

The following chapters, which contain the assessment of alternatives, are outlined in the following manner. First, the alternative or technology is described, with an explanation of the basic principles of operation. After this general description, each alternative is assessed against the datum, current practice.

## CHAPTER 5

### ALTERNATIVES TO INSPECTION

#### 5.1 Cable Replacement or Periodic Maintenance

In reviewing various new methods of inspection in search of the most effective, safest, and least expensive practice, one option to consider for improvement is the inspection strategy itself. With a main objective of spending less time in the water, there is the possibility of choosing not to conduct inspections at all. Unlike offshore platforms, pipelines, and similar marine structures, there are no statutory requirements to inspect underwater cables. In place of routine inspections, a policy could be adopted to either: a) allow the cable system to degrade until it is no longer serviceable, at which time the complete cable is replaced, or b) conduct periodic maintenance instead at specified intervals of time.

In considering the first option, of cable replacement instead of inspection, one would have to weigh the savings of not performing inspections over the life of the cable, against the cost of replacing the cable at some point in the future. One way to evaluate this alternative is through a traditional cost-benefit analysis. In a cost-benefit evaluation,

the best inspection, maintenance, and repair (IMR) policy is one which produces the lowest total expected cost of a system over its lifetime (Bea 1994b). Expected total cost is equal to the sum of initial costs plus future costs. Initial costs are all first costs associated with development of a system, plus costs for inspection and routine maintenance. Future costs include those costs associated with loss of serviceability, unscheduled repairs, and risk costs. Risk costs are difficult to calculate because they deal with the consequences of cable failure, which are themselves uncertain. The consequences of failure would vary considerably, and depend on the particular purpose of the cable. For example, if the cable is being used to track whales, the consequences of failure would not be nearly as significant as if the cables were being used to track submarines and protect the nation against enemy attacks. In either case, attaching a cost to the consequence of failure can be difficult. The cost-benefit approach is shown graphically in Figure 5-1.

Compared to the cost of cable replacement, cable inspection is considerably less expensive. The typical cost for cable inspection is approximately \$10,000 per nautical mile of inspection. This cost does not include the cost of labor, since UCT diver salaries are paid separately by the Navy. For remote locations such as Alaska, the cost of inspection is double this amount, or \$20,000 per nautical mile. The cost of cable replacement, however, is on the order of \$10 million per nautical mile for coaxial cables, and \$3 million per nautical mile for fiber optic cables (Holt 1994). One reason for the high cost of cable replacement may be the limited number of firms which specialize in underwater cable laying. The cost for laying coaxial cables is much higher than for fiber

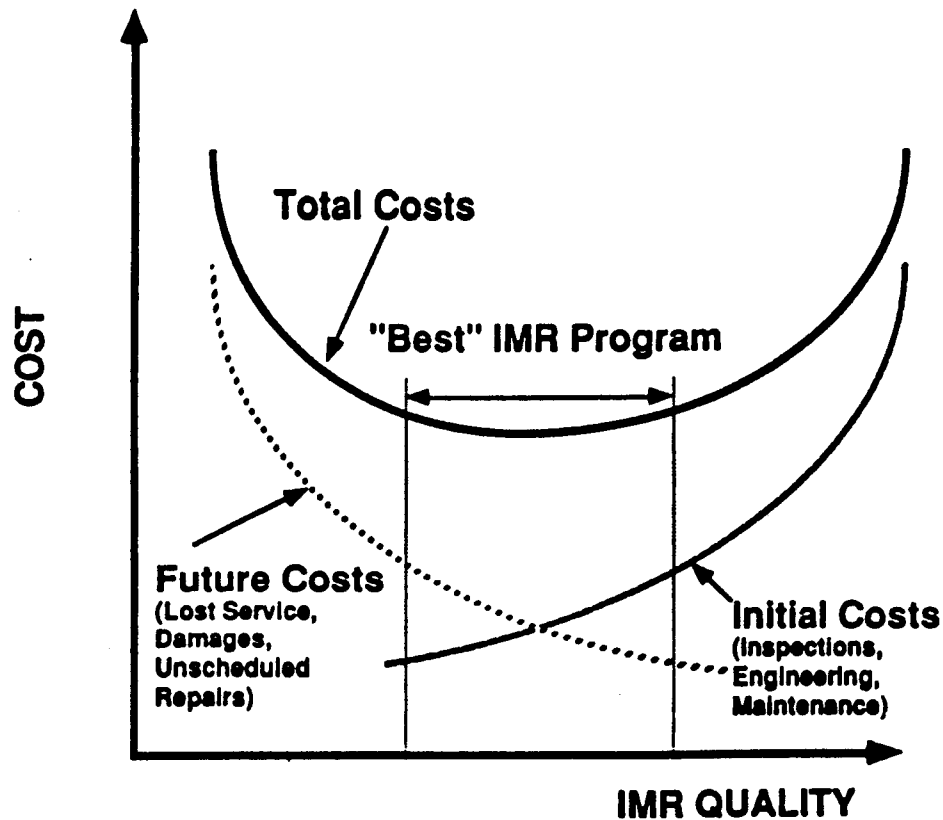

Figure 5-1. Cost Based Evaluation of Desirable IMR Quality (Bea 1994a).

optic cables because of the large winches required to handle the larger, heavier coaxial cables (Holt 1994). Since fiber optic cables are replacing the older coaxial cables, \$3 million is a more probable cost of replacement. Still, at \$3 million, the cables represent a major investment of capital.

Inspection of cables is important for catching defects before they become catastrophic. When dealing with structures in the ocean particularly, a small defect can grow quickly to the point of failure of the structure. For example, one year after installation, UCT Two inspected a fiber optic cable off the coast of Southern California

near San Nicholas Island. The inspection revealed that the cable was not designed adequately for the given wave and current conditions. A majority of the tie downs were no longer in place, and it was considered unlikely that the cable would have survived the next winter season. Based on the inspection, critical repairs were performed the next month to stabilize the cable. If the inspection had not been performed, or if the maintenance period for the cable had been every two years, the cable may have been irreparably damaged (Myrum 1994). Thus, with regular inspections, cables may last 25 years. However, if inspections are abandoned, cables may experience unexpected or premature loss.

Considering the magnitude of difference between cable inspection and cable replacement, it does not take a very detailed analysis to determine that regular inspection is worth the effort. Assuming an annual interest rate of 8% and a cable life of 10 years, the break-even point, where the annual cost of inspection is equivalent to the cost of cable replacement, occurs at an annual inspection cost of:

$$A = F(A/F, 8, 10) + F(A/F, 8, n)$$

where: A is the annual cost or annuity

$F(A/F, 8, 10)$  is the replacement cost amortized over the life of the cable

$F(A/F, 8, n)$  is the cost of temporary loss of service amortized over a period of n years (with the loss of service occurring in the nth year)

F is the cost at some future point in time

$(A/F, 8, 10)$  is the discounting factor to convert or equate the cost at some point in the future to an annual cost (assuming an annual effective interest rate of 8% and a cable life of 10 years);  $(A/F, i\%, n) = i/[(1+i)^n - 1]$

The second term of the above expression, cost of temporary loss of service, is a difficult term to determine, and depends on the use of the cables. For example, if there is loss of service while the cables are being used for surveillance of enemy submarines, the cost of temporary loss of service could be the cost to repair damages from a successful enemy attack on a city, or the cost to the United States of losing a war. This is a dramatic example, yet for less serious consequences, there is still a cost of temporary loss of service which is greater than zero. For ease of calculation, even if this term is ignored, the break-even point, where the annual cost of inspection is equivalent to the cost of cable replacement, occurs at an annual inspection cost of:

$$A = F(A/F, 8, 10) + (F(A/F, 8, n))$$

$$A = \$3 \text{ million}(0.0690) + 0 = \$207,088.$$

There are some cable applications where cable inspection can be foregone. This is a viable option if the material cost of the cable and its installation are very low compared to the cost of an inspection. For example, as a newer technology, the Navy is developing fiber optic cables which can be deployed quickly in a war-time scenario. The cables do not have armor protection and are meant to last for less than a week's time (Schofield 1994). In this case, inspection of the cables is irrelevant since they are designed for complete replacement at the end of their useful life.

The second alternative for not conducting inspections is to conduct periodic maintenance at intervals greater than the inspection interval. This option has several

disadvantages. First, periodic maintenance without inspection makes the scheduling of work difficult. Without the benefit of an inspection, the amount of time and money required to perform repairs, if needed, is not known. For the same reason, budgeting resources for repairs becomes more difficult without the benefit of inspection. Likewise, maintenance teams would need to travel to the site with a complete set of tools, since it would not be known exactly which tools are required for repairs.

## **5.2 Self-Inspecting Cables**

Another alternative for not conducting inspections is to equip the cable for "self inspection." The American Telephone and Telegraph Company (AT&T) has designed its underwater cable systems for self inspection. AT&T is responsible for thousands of miles of underwater cables in the world's oceans, but at no time do divers inspect the cables. This is because AT&T has designed their cables with a monitoring system which eliminates the need for actual physical inspection. Figure 5-2 illustrates the monitoring system.

Figure 5-2a is a schematic drawing of a typical underwater cable system, as AT&T would install it between three terminal stations on opposite sides of an ocean. The terminal station contains maintenance equipment, which is basically a computer terminal that enables station personnel to interrogate the performance of submerged repeaters. Repeaters are optical regenerators for transmission which can also be used to evaluate

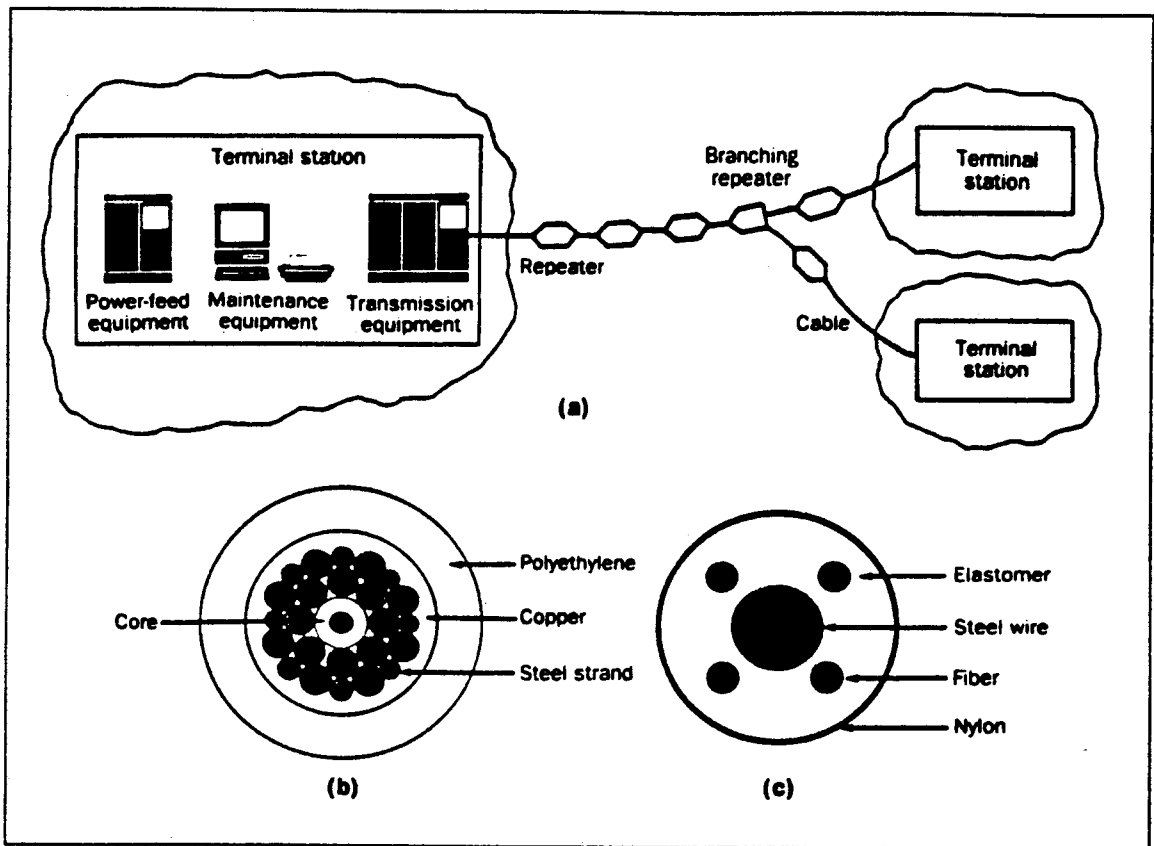

Figure 5-2. AT&T undersea lightwave transmission system. (a) Typical system between terminal stations on opposite sides of the ocean. (b) Cross section of an underwater cable. (c) Details of cable core. (Runge 1992).

system performance and re-route service. The power-feed equipment in the terminal stations supplies a constant current of 1.6A (amperes) that flows through the undersea cable and all repeaters in a series. If a fault occurs in the system, the maintenance computer can automatically locate the fault and initiate procedures to restore transmission, to bypass the fault, or to switch to redundant transmitters in the repeater (Runge 1992).

Figure 5-2b shows a cross-sectional view of the undersea cable, while Figure 5-2c depicts details of the core or center of the cable (Runge 1992). The AT&T cables themselves are not significantly different than those used by the Navy. The major

difference between the two systems is in the sophisticated computer equipment and software used by AT&T to monitor the repeaters and signal performance. For protection, AT&T buries their cables to a depth of one meter at the shore ends of a cable system (Runge 1992). Like Navy cables, AT&T cables are otherwise laid on the ocean bottom in deeper waters. While no underwater inspections are performed, when significant system degradation is noted, AT&T has six ships specially equipped to investigate the cable problem and perform any type of cable repairs needed (Watson 1994). The repair vessels are equipped with expensive machinery and ROVs. The cost of cable down time for AT&T exceeds the cost of the ROVs and specialized equipment.

AT&T would not release any information on the cost of their cable monitoring system, but based on available information, self-inspecting cables do not appear feasible for the Navy for several reasons: the level of training required of personnel interrogating the system and interpreting problems is high, and the cost of installing repeaters on cables plus the cost of the computer monitoring equipment would be prohibitive. For AT&T, these costs are justified based on the great amount of use of AT&T cables and consequences of loss of service. However, for the Navy, the high costs are not justified.

### **5.3 Improved Cable Siting**

Inspections are conducted to minimize maintenance and repair costs and extend the service life of underwater cables. In harsher environments, the cables must be

inspected at more frequent intervals to ensure the reliability. One of the ways to mitigate environmental and man-made hazards is to choose the best siting or routing before laying cables.

The ocean bottom is an extremely dynamic environment. Currents, storms, and waves can cause significant erosion and accretion of ocean bottom sediments in a brief time span. Seasonal variations in wave characteristics generally cause erosion in the winter and deposition or fill in the summer. A big storm or tsunami inundation can extensively erode a beach area in a matter of hours (Grace 1978). In addition, conditions in the nearshore area are extremely variable. Seafloor conditions in one region can be quite different than the conditions in a another region. For example, scouring may be prevalent in one area, whereas in a nearby area, there is much less tendency for scour. The bottom topography can be hilly, or it can be smooth and flat. By studying the seafloor conditions, therefore, a cable site can be chosen which identifies the best routing.

During the cold war period when the majority of hydrophone cables were laid, the emphasis was not on proper routing of the cables, but more on laying the cables in secrecy where they were not likely to interfere with other marine activities, or be discovered. In contrast, the bulk of cables laid today are range and communication cables where the situation and time allows for proper investigation on siting prior to laying the cables.

The basis for good cable siting to avoid hazardous conditions starts with detailed surveys and geological studies of potential routes. The conditions on the route should be defined as much as possible, including a study of fishing activities, waves and currents, faults, bottom topography, and soil profiles. Information should also be gathered on the geologic history of the potential route since the conditions underlying the seafloor can in some cases predict future hazards, such as mudslides, during the lifetime of the cable. There are many types of geophysical equipment which can be employed to gather information. Side-scan sonars, sub-bottom profilers, and soil coring are a few of the geophysical techniques which can provide data (Bea 1994a).

Other industries such as the pipeline and fishing industries have become very concerned with studying coastal conditions to determine the best or most favorable locations for routing. Poor routing can have serious consequences. For example, in a 1989 accident near Sabine Pass, Texas, eleven crew members died when their fishing vessel struck and ruptured a 16 inch diameter natural gas transmission line. As required by regulations, the pipeline had initially been buried during installation to a depth of three feet below the seafloor (Wilkey 1991). Unfortunately, the dynamics nature of the sea bottom resulted in removal of the sediments covering the pipeline.

The seafloor is continually changing. Besides natural forces such as waves, currents, and seasonal changes which affect the seafloor, construction of breakwaters and fishing activities which drag weighted nets also contribute to erosion and changes in the

seafloor. Studying site conditions and optimal routing can do nothing for the cables which are already laid of course, but it is an effective strategy for protecting future cables.

Trying to understand and determine local conditions prior to laying underwater cables can do much in the way of protecting cables by anticipating and avoiding hazards to provide the most stable environment possible. A stable environment will, in turn, lower inspection and maintenance costs over the lifetime of the cables.

#### 5.4 Assessment

**Reliability.** In the first years of operation, AT&T experienced difficulty with their cables and cable monitoring system because sharks were attracted to the equipment, and their bites could penetrate the cables (Runge 1992). After installing a protective layering of steel tape for fish-bite protection, AT&T reports that their monitoring system is very reliable (Watson 1994).

Cable replacement/periodic maintenance:	Not Applicable (N/A)
Self-inspecting cables:	+
Improved cable siting:	N/A

**Quality of results.** Self-monitoring systems are good for short term indications of where the cable is degrading or where it has failed, but they provide little information on the long term condition of the cable or whether the cable is in imminent danger.

Cable replacement/periodic maintenance:	NA
Self-inspecting cables:	-
Improved cable siting:	N/A

**Time.** It is not possible to determine the time involved with periodic maintenance or cable replacement without knowing the effect of letting the cable go without inspections. If the cable sustains little damage throughout its life, then presumably these methods would involve less time. Though self-inspecting, AT&T's cables require more time overall since personnel must monitor the system on a daily basis. One of the goals of improved cable siting is that placing the cable in a less hazardous location will result in fewer damages and less time for cable repairs and inspections. If the cable is sustaining little damage, it still takes time to inspect the cable, but the assumption is that less time will be needed to look at and document damage to cables. Whether or not this would actually be the case is difficult to determine.

Cable replacement/periodic maintenance:	Not Enough Information (NEI)
Self-inspecting cables:	-
Improved cable siting:	NEI

**Cost.** This criterion was discussed in earlier sections for cable replacement/periodic maintenance and self-inspecting cables. Regarding improved cable siting, again the assumption is that less damage to cables equates to less time for inspections and therefore a lower cost, but more information is needed to make this determination.

Cable replacement/periodic maintenance:	-
Self-inspecting cables:	-
Improved cable siting:	NEI

**Durability.** The computer equipment for AT&T's monitoring system requires care and is more fragile than diving gear, but it is not subjected to the marine environment. The other pieces of equipment, primarily the repeaters and the cable itself, are designed to be rugged

and to withstand the ocean environment on a daily basis. Self-inspecting cables are therefore rated higher than the current practice in durability.

Cable replacement/periodic maintenance:	NA
Self-inspecting cables:	+
Improved cable siting:	NA

**Affected by weather and dependence on visibility.** Self-inspecting cables are essentially independent of weather and visibility and are therefore rated higher than the datum.

Cable replacement/periodic maintenance:	NA
Self-inspecting cables:	+
Improved cable siting:	NA

**Manpower.** Manpower is rated the same as time for similar reasons. It is not possible to determine the manpower required for periodic maintenance or cable replacement without knowing the effect of letting the cable go without inspections. If the cable sustains little damage throughout its life, then presumably these methods would involve less manpower. Likewise, if improved cable siting results in fewer damages to the cable then less manpower is also needed. Though self-inspecting, AT&T's cables require more manpower overall since personnel must monitor the system on a daily basis.

Cable replacement/periodic maintenance:	NEI
Self-inspecting cables:	-
Improved cable siting:	NEI

**Training.** The amount of training required for AT&T's self-inspecting system is dependent in large part on how user-friendly the software is for monitoring and interrogating system performance. Since AT&T would not discuss many details on this

subject, there is not enough information to evaluate this criterion. For improved cable siting, it is envisioned that the study of site conditions would not be performed by the UCTs, but would instead be conducted by personnel at the Naval Facilities Engineering Service Center.

Cable replacement/periodic maintenance:	NA
Self-inspecting cables:	NEI
Improved cable siting:	NA

**Safety.** Safety will be determined mainly by the amount of diving activity involved. As with the criteria *time* and *manpower*, it is not possible to determine the amount of diving activity involved with periodic maintenance or cable replacement without knowing the effect of letting the cable go without inspections, and the amount of damage that will be sustained throughout its life. A self inspecting cable system has the advantage of being a safer system since it eliminates inspection diving. With improved cable siting, the assumption is that a less hazardous location will result in fewer damages, and less diving for inspection and repair; therefore a safer operation.. Again, whether or not this would actually be the case is difficult to determine.

Cable replacement/periodic maintenance:	NEI
Self-inspecting cables:	+
Improved cable siting:	NEI

**Portability.** Since periodic maintenance would necessitate being prepared for any repairs, this alternative is a less portable option since more equipment and tools would be required. The self-inspecting system is more portable than the datum since it does not require any equipment to be shipped from site to site for inspections.

Cable replacement/periodic maintenance:	-
---	---

Self-inspecting cables:	+
Improved cable siting:	NA

**Ease of use.** A self-inspecting cable system would be easy to use compared to the datum because it would involve operating a computer rather than dive equipment. Operating training may be required, but using the computer itself would be easy.

Cable replacement/periodic maintenance:	NA
Self-inspecting cables:	+
Improved cable siting:	NA

**CHAPTER 6**  
**INVESTIGATION OF TECHNOLOGY**  
**TO IMPROVE CABLE INSPECTIONS**

For purpose of analysis, the cable inspection can be characterized by three phases: 1) determining a reference system to document, by survey, the location of the cable, thus enabling inspection teams to consistently return to the same location, 2) physically finding the cable, and 3) investigating the condition of the cable. The first part of this chapter explores global positioning systems, or GPS, to determine an initial starting point to begin looking for the cable. Next, since physically finding the cables represents the biggest obstacle to an inspection, a major part of Chapter 6 is devoted to different cable location methods, both active and passive. Finally, the possibility of using remotely operated vehicles for inspection of cables is studied.

**6.1 Cable Survey Using a Global Positioning System**

In a little more than 20 years, global positioning systems, or GPS, has advanced from an idea to the reality that for less than a thousand dollars, anyone, anywhere in the world, can almost instantaneously determine position to about 10 meters or the width of a

street (Parkinson 1994). GPS was designed and developed by the Department of Defense primarily for two purposes: 1) precise weapon delivery, and 2) universal navigation for all branches of the military (to reduce the proliferation of navigation systems in the military). Though developed by the Department of Defense for military purposes, global positioning has matured into a valuable technology with many commercial applications. The benefits of GPS are being realized not only in commercial ocean and air navigation, but for a variety of uses not envisioned by its designers. GPS is used for tracking oil spills to minimize the severity of damages, precise application of fertilizers as farmers navigate their crop fields, and as a replacement for road maps in automobiles. GPS has also become a useful tool for surveying, and it is in this area that GPS could improve the current method of cable surveys.

### **6.1.1 Fundamentals of Global Positioning**

The GPS system, or network, consists of three components: the satellite system, the ground-based control system, and the user segment. Figure 6-1 illustrates the three essential components of GPS.

Satellite system. In the early days of navigation, ship captains charted their course using the stars to navigate. Today, GPS operates on similar principles, using a man-made satellite “constellation” instead of the stars. To provide world-wide coverage, the current satellite configuration consists of 24 satellites, organized in six orbital planes with four

satellites in each orbit. The satellites are oriented at a 55 degree inclination, and orbit at an altitude of 10,980 nautical miles (Parkinson 1994).

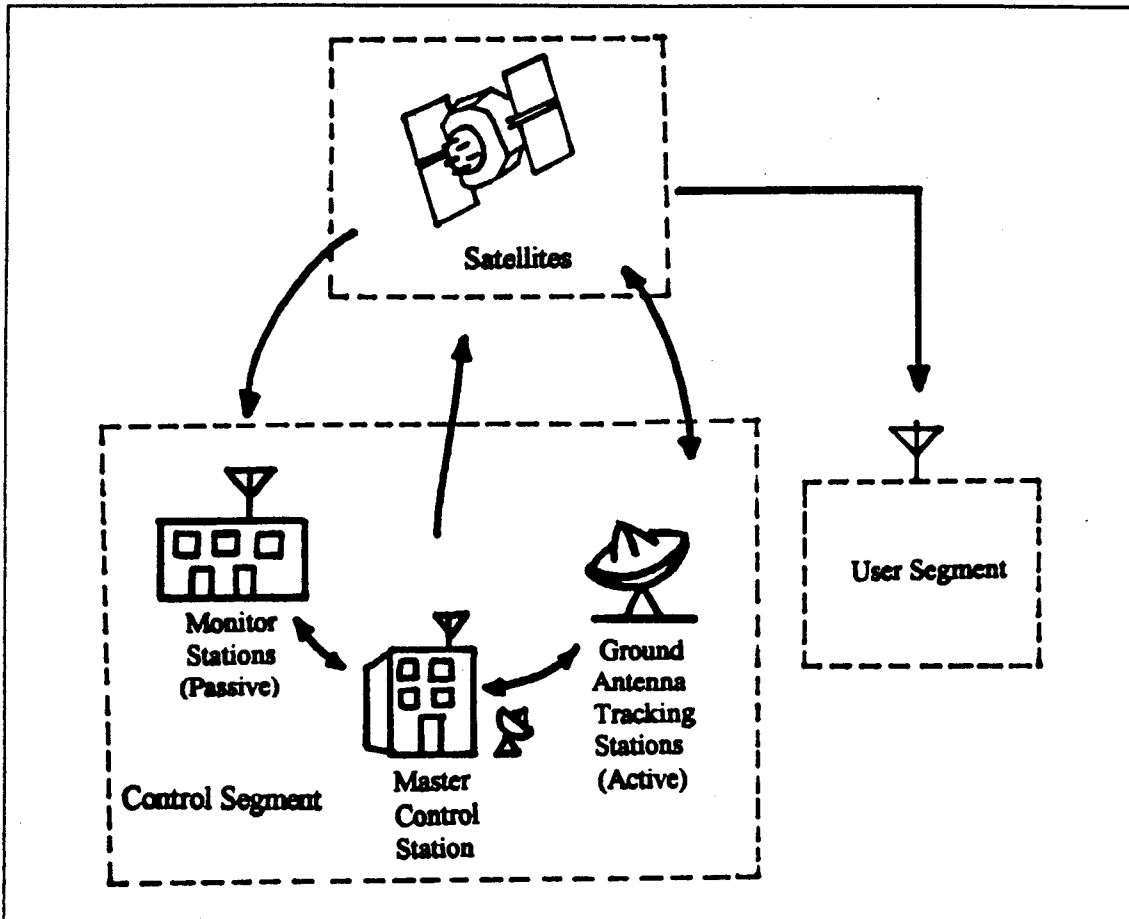

Figure 6-1. Global positioning system network.

GPS position determination is based on one way ranging to four GPS satellites simultaneously in view. Each satellite broadcasts the following information in a 1500 bit word, at a 50 bit per second rate (Masters 1993):

- Satellite ephemeris, or orbit position
- Time of day
- Signal propagation information
- Satellite operational status
- Acquisition information on other satellites
- Special messages

The satellite broadcast of orbit position and time are the two most important pieces of information for determining position. The range to each satellite is measured by matching the satellite's broadcasted signal with a user-generated replica signal and measuring the received phase against the user's (relatively crude) crystal clock. The time lapse of the incoming signal determines the range to each satellite. Using the geometry of satellite position and the ranges to four satellites, users can then determine four unknowns: typically latitude, longitude, altitude, and a correction to the user's clock.

Ground-based control system. The function of the control segment is to track the satellites, determine signal propagation corrections, satellite timing errors, and other system parameters, and uplink that information to the satellites, to be re-transmitted by the satellites to the users. In other words, each satellite cannot broadcast its position to users without first being "told" by the ground-based tracking system where it is located. The GPS master control station is located at Falcon Air Force Base, twelve miles east of Colorado Springs, Colorado. The master control station is the central node for processing satellite telemetry and monitoring navigation performance. It is run by the Air Force's 2nd Space Operations Squadron, which is the sole agency to effect repairs. The GPS system also includes four active-tracking ground antennas and five passive-tracking monitor stations located across the globe in Colorado Springs and the islands of Hawaii, Ascension, Diego Garcia, and Kwajalein.

User segment. The user segment consists basically of a GPS receiver which computes position using geometry and the range to at least four satellites. Each satellite is identified by comparing its broadcast code against a stored set of codes in the user's receiver. Today there are over 300 receiver units available from approximately 50 manufacturers (GPS World 1994). As GPS has evolved in the last decade, the equipment has become progressively better and less expensive. Receivers are very portable units, and many are designed to be hand-held. When using differential GPS for improved accuracy, an antenna for differential corrections is required, however, the antennas are also designed to be quite portable. Prices for receivers range from \$400 to \$60,000 depending on the application, options offered, accuracy, etc. The time it takes for a receiver to first fix a position also varies. Since the satellite message is 1500 bits long and is transmitted at a 50 bits per second rate, the minimum time to achieve a first fix is 30 seconds.

### **6.1.2 Capabilities of GPS and DGPS**

Although GPS was developed by and for the military, its designers recognized that other non-military uses would develop, and hence felt a need to protect the capability of the technology. There were legitimate fears that the GPS system could potentially be used against its very builders, the U.S. military. For this reason, a policy of "Selective Availability," or SA, was activated by the Department of Defense in March 1990 (Bennett 1991). Selective Availability is the intentional degrading of the accuracy of signals by altering the satellite position and/or clock data broadcast. Authorized (military) operators

are able to use receivers specially equipped with cryptographic keys to correct deliberate errors. SA-induced errors can be varied, with current GPS accuracy of 100 meters, 95 percent of the time.

The accuracy of GPS is related to the satellite broadcast of C/A and P-codes. The GPS ranging signal is broadcast at a primary frequency of 1575 MHz (called L1), and a secondary frequency of 1227 MHz (called L2). These signals are generated synchronously, so that a user who receives both signals can directly calibrate the ionospheric group delay and apply appropriate corrections. Current implementation has two modulations on the L1 frequency (C/A code and P-code), and one modulation on the L2 frequency (P-code). The two modulations are further described below (Parkinson 1994):

***C/A -code or clear acquisition code.*** This is a short code broadcast at a bit rate of 1.023 MHz. This signal is the civilian code and is therefore always available and broadcast clear (unencrypted). Use of the C/A-code is called the standard Positioning Service or SPS. Some civilian users have requested C/A modulation on the L2 frequency to allow for ionospheric calibration, but at this time, C/A is only available on L1.

***P-code or precise code (sometimes called the protected code).*** The P-code is a long, seven day binary sequence on the 1275 MHz signal. The P-code is broadcast at ten times the rate of the C/A-code, or 10.23 MHz. This signal provides the precise positioning signal or PPS. The military has decided to encrypt this signal, making it unavailable to the unauthorized user. When encrypted, the P-code becomes the Y-code, which can be decrypted with P/Y-code receivers. As this is a military code, most civilian users rely only on the C/A signal. The long P-code is intended to provide maximum timing accuracy and maximum security.

The significance of the C/A and P-codes is in accuracy. Users with access to C/A-code only can determine position within 100 meters, while access to P-code allows position accuracy to 10 meters (without differential corrections applied). To get around the encrypted P-code and improve the accuracy imposed by a policy of selective availability or SA, civilian companies developed differential navigation systems, or DGPS. Besides decreasing error caused by SA, DGPS also decreases other sources of error, such as error caused by ionospheric or tropospheric propagation delay, satellite ephemeris error, or non-SA satellite clock errors.

DGPS systems operate on the principle that a receiver, when placed at a known position, can determine the range error by comparing the receiver computed location against the known location. If the derived error information is then transmitted to another receiver, this second receiver can incorporate the error information, and determine its position with a greater amount of accuracy. In this fashion, real-time position can be achieved at accuracies of 3 meters at a 95 percent probability level using C/A code (Langley 1994). A similar approach using carrier-phase measurements is also possible, giving accuracies at the centimeter level, but post-processing is necessary for this accuracy.

In practice, the error information or range corrections can be transmitted from a reference station to the user through various communication datalinks. A DGPS user can either use a public or commercial DGPS service. The Coast Guard has equipped a number

of radiobeacons under its control to transmit range corrections to DGPS users. The error corrections are transmitted in the low frequency band of the radio spectrum (30 to 300 kHz). The useful range of the DGPS radiobeacons is 150 kilometers over water and from 20 to 100 kilometers inland. DGPS range corrections are also broadcast from commercial reference stations operating in the MF band at frequencies in the vicinity of 2 MHz. The range of MF systems is typically about 400 kilometers over water and about 50 kilometers over land. Another option for receiving differential range corrections is by satellite. The International Maritime Satellite Organization (Inmarsat), Starfix, and low earth orbit (LEO) satellites are typically used for DGPS error corrections. DGPS satellite broadcasts provide global coverage for transmission of range corrections (Langley 1993).

### 6.1.3 GPS Assessment

Global positioning offers an improvement to UCTs in determining a starting position to locate the cable and for surveying the cable. GPS eliminates the need for setting up survey stations on shore, and thus eliminates the need to clear any vegetation obstructing the line of sight of survey stations. A survey of the cable with GPS would be accomplished in essentially the same manner as with survey equipment, using floats as the link between the divers and the diving platform where position is marked. The difference would be in using a GPS receiver topside on the diving platform to mark position as opposed to taking bearings from shore.

**Reliability.** GPS equipment, although very new, has proven to be reliable in practice.

The recent Persian Gulf conflict was a proving ground for the reliability and durability of GPS receiving equipment (Wysocki 1991).

GPS: same

**Quality of results.** Since the UCTs are military units, they would be allowed access to P/Y-code receivers for position accuracy. P/Y-code receivers, applying differential corrections can achieve accuracy to within one meter. Even without P/Y-code capability, the differential GPS accuracy of 3 meters provides an adequate point of reference for consistently returning to the same location to look for the cable.

GPS: same

**Time.** GPS offers a time savings for initially selecting a starting point to look for the cable. During a survey, however, GPS marking the position of the cable at 100 intervals requires at least 30 seconds of receiver processing time to fix position, which is on the same order as the current method.

GPS: time to determine initial position: +  
time to survey: same

**Cost.** The range in prices for receivers varies greatly. Many receiver units cost under \$1,000. Typical receiver systems for a higher degree of accuracy (equipped to accept DGPS corrections or P/Y-code) are more expensive, but can still be purchased for several

thousand dollars. Survey equipment also varies greatly in price, yet is higher than the GPS price tag - two theodolites and an electronic distance meter cost approximately \$10,000.

GPS: +

**Durability.** GPS equipment has been designed in general for rugged use in the field.

Since survey equipment is also designed for rough field conditions, GPS is rated the same for this criteria.

GPS: same

**Affected by weather/ Dependence on visibility.** Under most conditions, GPS and survey equipment are affected equally by weather conditions. In foggy weather, however, GPS would provide an advantage over survey equipment. With standard survey equipment, foggy weather would make it more difficult to take bearings to the diving platform to determine an initial starting point to look for the cable or to survey the position of the cable.

GPS: +

**Manpower.** Surveying a cable using GPS does not require as much manpower as with traditional survey equipment since it eliminates the need for personnel on shore taking bearings to the diving platform at 100 foot intervals.

GPS: +

**Training.** Unlike survey equipment, the GPS hand-held receivers require no training at all to use. The unit simply outputs the position in latitude and longitude coordinates, or other desired position systems selected by the user. Granted, the lat./long coordinates would later need to be transferred or plotted on a map, but the current system also requires post processing of the bearings. Some hydrographic survey software systems are available which can be integrated with the GPS receiver for a real-time plot, however, these systems are fairly expensive. For example, according to product literature, Motorola makes a rugged hydrographic survey unit packaged conveniently as a single, integrated unit, but it comes at a price of \$27,950 (Motorola 1994).

GPS: +

**Safety.** The GPS equipment itself is not any safer than the survey equipment used in the current practice for determining position. However, any method which decreases the amount of time in the water is a safer method. Since GPS can save time in determining an initial starting point to look for the cable, it is rated as safer than the current practice.

GPS: +

**Portability and ease of use.** GPS equipment rates high in these categories since receivers are designed to be small, portable, and in many cases, hand-held units. Differential GPS support equipment and antennas are also portable and easy to use.

GPS: +

## 6.2 Active Cable Location

Once the inspection team is in the vicinity of the cable's last known position from previous inspections, there is still the task of physically finding the cable in order to inspect it. Location methods can generally be categorized as either active or passive systems. Devices are said to be *active* when some type of radiation is purposely generated to be reflected off a target (cable), and received again by the device. Active systems involve two way transmission through the medium, in this case, the sea.

### 6.2.1 Geophysical Methods

Geophysical methods have been used for years in the marine industry for a variety of applications. Geophysical devices operate on the principal of acoustic or seismic propagation. Acoustic waves are based on the vibration of the actual material which is the medium itself; acoustic waves constitute the periodic variation of pressure in the medium. The term "acoustic" has come to mean more than waves with frequencies in the audible range. Frequencies which are useful for acoustic propagation in the ocean range from approximately 30 Hz to 1 MHz. Active geophysical devices include echosounders, side scan sonar, sub-bottom profilers, and seismic sources. Echo sounders are used to determine bathymetric contours, the slope of the seafloor, or the location of morphological features such as shallows, deeps, and reefs. Side scan sonar detects bathymetric irregularities and can be used as a search tool for items on the seafloor; sonographs from side scan sonar allow complete mapping of features such as geologic

outcrops, variations in surface lithology, or sunken wrecks. The sub-bottom profiler allows for high resolution seismic profile recordings of the uppermost 30 meters of strata below the seafloor, while seismic devices can achieve subsurface penetration of 1000 meters.

The main difference between each type of geophysical device described above is the frequency at which the system operates. Table 6-1 lists the frequency range and penetration achieved below the seafloor.

TABLE 6-1  
GENERAL CHARACTERISTICS OF GEOPHYSICAL SENSORS

Sensor System	Frequency Range (kHz)	Typical Penetration (meters)
Echo sounders	10-200	0-1
Side Scan Sonars	10-500	—
Sub-bottom Profilers	1.0-10	10-30
Chirp Sonar	200 Hz-30 kHz	100
Seismic Reflection	50-250 Hz	1000

Source: Trabant 1984

Another difference between the geophysical devices is the equipment required to operate at that frequency. For example, the equipment for sub-bottom profiling is similar to the equipment used for echosounders in circuitry, except for proportional dimensions.

The sub-bottom profiling equipment is larger since it must generate higher power outputs to operate at lower frequencies.

Of the geophysical devices available, side scan sonar and sub-bottom profilers are the most promising for locating or surveying cables. Echo sounders are used primarily for determining information on the depth of the water or the bathymetry of sea bottom. While seismic devices can penetrate 1000 meters into the seafloor, this amount of penetration is not necessary for cable location or surveying. The side scan sonar and sub-bottom profiler are described in more detail below.

**Side Scan Sonar.** Side scan sonar has been a principal search tool for seabed investigation since the technology was developed in the 1950s. With the advent of computers and better processing techniques, gathering information about the seafloor has become easier, less expensive, and less time consuming. Present day enhancements to side scan sonar include digital signal processing of the acoustic data; multiple frequency capability; enhanced sonar imagery, with video representation of the seafloor acoustic data; and recording on permanent media (Abrams 1990).

The principle of operation of side scan sonar is the transmission of sound pulses along narrow fan-shaped beams slightly depressed ( $10^{\circ}$  to  $20^{\circ}$ ) with respect to the horizontal (sea level), from transducers pointed to either side of the vessel's track. Echoes from protrusions arrive back first, and the recorded echoes produce an oblique plan view

of the texture of the seafloor (Trabant 1984). Side scan sonar transducers are typically mounted on a towed "fish" device, which must be towed far enough away from the vessel to avoid noise. A separate acoustic tracking instrument may then be required to determine the location of the fish. The resolution of side scan sonar is a function of several factors such as signal beam width, frequency, pulse length, and recording method, but is typically equal to one-thousandth of the operating range. More important than the theoretical limitations in resolution, however, is the acoustic reflectivity. Thus, even a small diameter cable will produce a strong reflector because it is a long coherent target (Trabant 1984). The coverage provided on either side of the towfish by side scan sonar depends on the frequency of the side scan sonar. Short-range systems operating in the 100 to 500 kHz range provide coverage out to about 300 meters. Long range units operating at 10 kHz can cover on the order of 20 kilometers to either side of the vessel's track. Figure 6-2 shows a side scan sonar in operation.

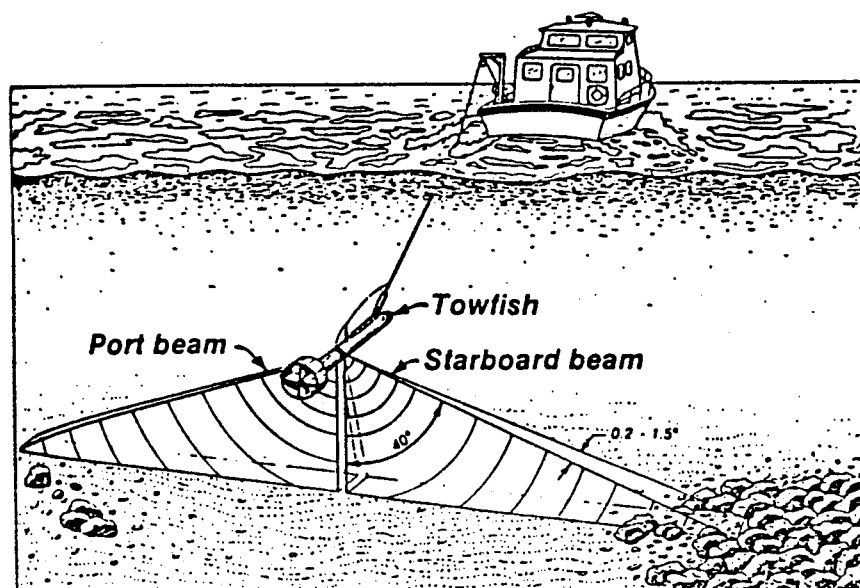

Figure 6-2. Side scan sonar in operation (Buffkin 1990).

**Sub-bottom Profilers.** High resolution seismic reflection systems which operate in the frequency range of 1.0 to 14.0 kHz are grouped within the general category of sub-bottom profilers. Sub-bottom profilers offer an advantage over side scan sonar if looking for an object beneath the seafloor, with the capability to penetrate into the seafloor. The equipment for sub-bottom profilers is larger, but very similar to, the equipment used for side scan sonar systems. The sub-bottom profiler transducer which emits the seismic waves is also typically deployed on a towfish, or it can be mounted on the hull of the ship. The output is generated in real time on a recorder. As seismic waves propagate in a spherical fashion through the water column and sediments, they may be reflected by geological or man-made features that act as a point source to produce diffraction patterns. While diffraction is usually considered interference, diffraction signals can identify cables on or beneath the sea floor (Trabant 1984). The presence of a cable detected with a sub-bottom profiler appears on the recorder as an inverted hyperbola of diffraction. Figure 6-3 represents the diffraction pattern which indicates an object such as a pipeline or a cable.

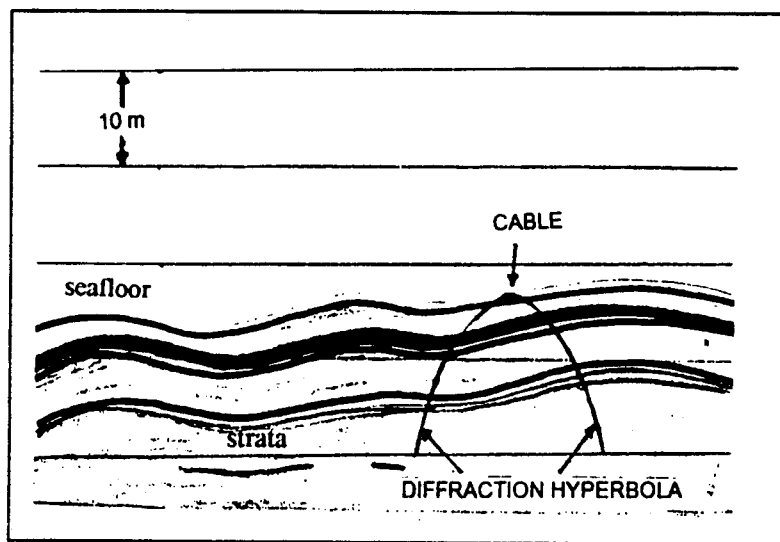

Figure 6-3. Representation of a diffraction hyperbola.

Since the mid 1970s, digitization of the analog reflection data has allowed further processing and manipulation to increase the quality of the output of sub-bottom profilers. The newest development in sub-bottom profiling is Chirp sonar. Chirp sonar is a wide band sonar that transmits computer generated FM pulses that sweep over the frequency range of 200 Hz to 30 kHz. The effect of sweeping the frequency is to widen the bandwidth. With such a wide bandwidth, sediment layers as thin as 5 centimeters can be resolved. Additionally, excitation voltage for the transducer is digitally controlled to prevent source ringing, which is a common problem that reduces the resolution of short pulse systems. Chirp sonar was developed at the University of Rhode Island under a program started in 1981. After several years of microprocessing and digital signal processing redesign, the first commercial version of the sonar became available in 1990. The system computer, display, and amplifiers are packaged within a small rack and are designed to be set up, checked out, and generating images in less than 10 minutes by personnel with little prior sub-bottom profiling experience (Schock 1990).

**Radar.** Whereas side scan sonar and sub-bottom profiling rely on acoustic waves, radar uses the transmission, reflection, and reception of electromagnetic waves to derive information. The speed of light, at which electromagnetic waves propagate, is different for different media. Additionally, the attenuation of the power in the propagating electromagnetic wave is a function of the frequency and the medium through which it is traveling.

Ground penetrating radar (GPR) is an application of radar which has been used successfully in a variety of applications such as non-destructive detection of deterioration in bridge decks, monitoring highway pavement sub-base layers, or locating buried objects (unexploded ordnance, hazardous waste storage containers). GPR is the electromagnetic equivalent of ultrasound: short pulses of electromagnetic energy are transmitted by an antenna into a dielectric medium. These pulses are reflected from interfaces in the medium where dielectric properties change, such as material boundaries or metal objects (Maser and Roddis 1990).

Although radar works well for penetrating ground, and may appear to have the potential for observing objects underwater, the electromagnetic properties of soil and seawater are greatly different. The relative dielectric constant (or permittivity) of a material is one measure of how well electromagnetic waves will propagate in the medium. Soils have relative dielectric constants ranging from 4 for dry sand to 20 for wet clay (Koppenjan and Bashforth 1993). The more conductive the medium, the higher the relative dielectric constant. Distilled water has a dielectric constant of 80, and salt water is even greater than that due to salinity. Because of the conductivity of sea water, the attenuation depth (or penetration depth) of the electromagnetic wave is not more than a portion of the wavelength of the carrier. This is typically in the range of centimeters for normal radar frequencies used (Wadsworth, Deroin, and Rudant 1991). For this reason, even though radar is showing increased application in locating underground objects, it is not feasible for penetrating seawater to locate submerged objects.

While electromagnetic radar waves are not capable of penetrating seawater, radar may still be useful in the future for locating objects on the seafloor. Radar is currently being used to indirectly map features of the ocean bottom in shallow water; under favorable meteorological and hydrodynamic conditions, the bottom topography of shallow seas can be mapped with airborne or space-borne imaging radar. This technique uses synthetic aperture radar (SAR) to build a radar picture of the ocean surface in the area of interest. SAR employs a synthesis of numerous observations at a target to develop greater resolution than would be possible with a single observation. It usually involves a side looking radar which does not scan, but allows the radar platform's motion (i.e. satellite, helicopter, airplane, etc.) to sweep the ground footprint of the radar across the target. As the footprint sweeps across the target, the radar obtains many observations at a particular spot within that footprint on each pulse and from slightly different angles as the platform passes the target. Through computer processing of these numerous observations at spots on the ground, a high resolution synthesis picture of the area can be developed.

SAR is able to map the sea bottom topography using a 3-step imaging technique (Vogelzang and others 1991):

1. Interaction between (tidal ) current and bottom topography causes spatial modulations in the surface current velocity.
2. Modulations in the surface current velocity give rise to variations in the spectrum of wind-generated waves.
3. Variations in the wave spectrum show up as intensity modulations in radar imagery.

In other words, through numerous pictures with the SAR and with advanced processing techniques, the bottom topography is mapped by "reading" the surface of the ocean. In a 1989 joint experiment conducted by NASA and the Dutch Sea Bottom Topography Group, radar images were compared to digitized bathymetric maps to determine the accuracy of the models employed for the imaging technique. Although the resolution demonstrated in the experiments was only on the order of 10 meters (Vogelzang and others 1991), which is much too large to locate an underwater cable 6 inches or less in diameter, possible future increases in resolution through better models and further processing of the images could present a viable method for locating small subsurface bottom features, such as a cable laying on the bottom. Radar does not, however, show much promise in any way if the cable is submerged below the seafloor.

**Electro-magnetic locators (metal detectors)**. The cable tracker instrument currently used by the UCTs is an example of an electro-magnetic locator. Other examples of electro-magnetic locators are pulse-induced metal detectors. Pulse induced systems operate by intermittently pulsing an electric current into a coil to create a high energy magnetic field. When a transmitted pulse hits a metallic object, this causes eddy currents to begin to flow in the metal, which in turn generates a second magnetic field. This second magnetic field is then sensed, amplified, and displayed (Thomson 1993). Pulse-induced systems are not included in this assessment because the Naval Facilities Engineering Service Center evaluated these systems for UCT use in a 1993 study. The

evaluation included testing of several marine pulse-induced systems in the ocean, evaluating them on the basis of factors such as ruggedness, general handling, and output, etc. The evaluation resulted in adapting the Forster Ferex metal locator for UCT use (Thomson 1993). The Forster Ferex cable locating tool is not an active, pulse-induced system, but rather a passive magnetometer.

### 6.2.3 Active Cable Location Assessment

As radar resolution is not refined enough for searching the sea bed to date, the technology cannot be rated in most of the following categories.

**Reliability.** Side scan sonar and sub-bottom profiling equipment have been on the market and used reliably for several decades, improving throughout the years. Radar, on the other hand, is a new and untested technology for cable location.

Side scan sonar:	same
Sub-bottom profiler:	same
Radar:	-

**Quality of results.** With respect to active cable location devices, quality of results refers mainly to whether or not the cable can be found. Side scan sonar is rated below the current practice if the cables are buried since it cannot penetrate the seafloor. Sub-bottom profiler are rated higher in this category since they can locate buried objects. Objects such as pipes or cables appear as inverted hyperbola on the recorder. If the cable is exposed, the quality of results for side scan and sub-bottom profiling is considered the same as the

current method since an exposed cable will be found in any of these cases.

	<u>exposed</u>	<u>buried</u>
Side scan sonar:	same	-
Sub-bottom profiler:	same	+
Radar:	NEI	-

**Time.** The ratings for time are exactly the same as the ratings for quality of results for the simple reason that if the device can locate the cable when it is buried, then less time is expended in the search. Since side scan sonar picks up irregularities on the seafloor but cannot penetrate the seafloor, this instrument does not constitute a time savings over the current practice. Similarly, radar would never constitute a time savings if cables are buried since it does not have the ability to penetrate the seafloor. Sub-bottom profilers, on the other hand, could save time in the cable search, since they have the ability to penetrate the seafloor. Once the cable is found, both side scan sonar and sub-bottom profilers could potentially save time when conducting a survey because they can make a relatively quick sweep of the one nautical mile of cable from the beach area to the offshore junction box. When the position of an object is not known with much certainty (such as a sunken vessel), sonar search procedures can be lengthy because they involve searching in a methodical pattern. Involved search patterns would not be required in the case of cables since the uncertainty of their location is relatively small, particularly when compared to a 300 meter range on either side of a towfish.

	<u>exposed</u>	<u>buried</u>	<u>time for survey</u>
Side scan sonar:	same	-	+
Sub-bottom profiler:	same	+	+
Radar:	NEI	-	NEI

**Cost.** Geophysical devices are notably more expensive than current equipment. For example, the EG&G side scan sonar system discussed previously sells for \$58,800 (Schaaf 1994).

Side scan sonar:	-
Sub-bottom profiler:	-
Radar:	-

**Durability.** The durability of side scan sonar and sub-bottom equipment is not as good as basic dive gear. These systems are equally durable when compared to the cable tracker and metal locator tools currently used by the UCTs.

Side scan sonar:	-/same
Sub-bottom profiler:	-/same
Radar:	NEI

**Affected by the weather.** The limitations of geophysical devices regarding weather are the same as the current practice in that surface towed systems cannot operate in sea states corresponding to wind conditions of greater than Force 4 on the Beaufort scale due to surface turbulence and wave action (Milne 1980). Radar, if operated from an aircraft, would not be affected by ocean waves, but would be affected by stormy atmospheric conditions.

Side scan sonar:	same
Sub-bottom profiler:	same
Radar:	same

**Dependence on visibility.** Sonar devices gain an advantage over the current practice where visibility is concerned. Whereas divers need a certain amount of visibility to see a

cable, acoustic devices are independent of the visibility. Radar is dependent not on the visibility through the ocean, but on transmission through the atmosphere.

Side scan sonar:	+
Sub-bottom profiler:	+
Radar:	same

**Manpower.** The manpower required to use the geophysical devices is not any better than the current practice. The devices keep the divers out of the water, yet personnel are needed for monitoring the strip chart data recorder, simultaneously marking navigation fixes as the cable is noted on the strip chart output recorder, tending the towfish cable, and operating the vessel.

Side scan sonar:	same
Sub-bottom profiler:	same
Radar:	NEI

**Training.** Although geophysical devices do require training to operate, and to be able to interpret sonograph images, this training is not nearly as extensive as the training to be a navy or commercial diver.

Side scan sonar:	+
Sub-bottom profiler:	+
Radar:	NEI

**Safety.** Side scan sonar and sub-bottom profilers are considered safer than the current practice since the methods keep divers out of the water during location of the cable. Radar is not rated safer than the current practice since the platform for radar systems would be an aircraft or satellite, which is not necessarily safer.

Side scan sonar:	+
Sub-bottom profiler:	+

Radar: NEI

**Portability.** The basic pieces of equipment required for side scan sonar operation include the towfish, the deck unit which provides images of the seafloor, and the tow cable which supplies power to the fish from the deck unit. Tow cable is typically used in a 3:1 ratio, meaning approximately 300 feet of cable is required to operate in 100 foot depths. Side scan sonar equipment varies in size and shape from one manufacturer to another, but can be quite portable. For example, EG&G's side scan sonar system weighs 170 pounds total (55 lbs - towfish, 20 lbs - cable, and 95 lbs - deck unit). Considering the weight of double scuba tanks for each diver and the lead weights each diver wears for neutral buoyancy, plus the weight of the cable location tools, the side scan sonar system is lighter, smaller, and more portable than the current equipment. Sub-bottom profiling equipment, however, is not nearly as portable. Many towfish devices are made to accommodate both a side scan sonar and a sub-bottom profiler, which requires a significantly larger fish. The deck unit for a sub-bottom profiler is also much larger since it must generate more power to operate in a lower frequency range and to drive a larger fish. The sub-bottom profiler, therefore, is not as portable as the current equipment.

Side scan sonar: +  
Sub-bottom profiler: -  
Radar: NEI

**Ease of use.** Even with improvements in the technology throughout the years, side scan sonar and sub-bottom profilers still require basic level skill to operate and to interpret the

output records. The side scan sonar may be considered easier to use than the current cable locating tools, otherwise the current dive equipment rates higher in ease of use.

Side scan sonar:	-/+
Sub-bottom profiler:	-/+
Radar:	NEI

### **6.3 Passive Cable Location**

Whereas active systems operate on two way transmission of a signal, passive systems involve only one way transmission of a signal through the sea. Passive location devices are listening systems designed to detect a signal from a source (cable). There are a number of passive location devices available for the marine environment. Many of these devices operate on the principle of sensing magnetic fields, and measuring small variations, or anomalies, in the earth's naturally occurring magnetic field. Other devices involve looking for visual markers or listening for acoustic signals from a source. Several passive location devices are discussed below.

#### **6.3.1 Magnetometers/Gradiometers**

The earth's magnetic field has a complex flux distribution which varies between approximately 25,000  $\gamma$  (gamma) at the magnetic equator, and 65,000  $\gamma$  at the magnetic poles. The magnetic field created by a cable is on the order of 50  $\gamma$ . There are several ways to detect the variation in the earth's magnetic field caused by a cable.

Fluxgate magnetometers are based on a core of highly permeable material, wound with primary and secondary coils. The core is driven in and out of saturation by a low frequency electrical signal. This saturation, which is affected by changes in the total ambient magnetic field, is sensed by a separate winding, and amplified to provide a signal output to the operator (Milne 1980). When a pair of fluxgate sensors are used together, separated by a fixed distance, they form a gradiometer. The difference in readings between the two sensors, divided by the distance between them, provides a gradient, or rate of change of the magnetic lines of flux. In practice, three fluxgate magnetometers are commonly used to form a gradiometer array. The sensors are placed approximately one meter apart. A schematic drawing of a gradiometer array is shown in Figure 6-4.

Gradiometer arrays have shown great success in locating buried pipelines and cables. The array is typically deployed from a remotely operated vehicle since the arrays are used mainly for deep water applications. For UCT use, the gradiometer array could potentially be deployed from a submerged sled base. This option is being pursued by the pipeline industry for shallow water areas (Wilkey 1991). The fluxgate sensors themselves are not large, commonly 2 to 3 inches in diameter and 1 to 1.5 feet in length. To successfully locate cables, the sensors of the gradiometer need to be within 10 feet of the cable. In nearshore areas, keeping the sensors close to the seafloor demands care since depth changes quickly.

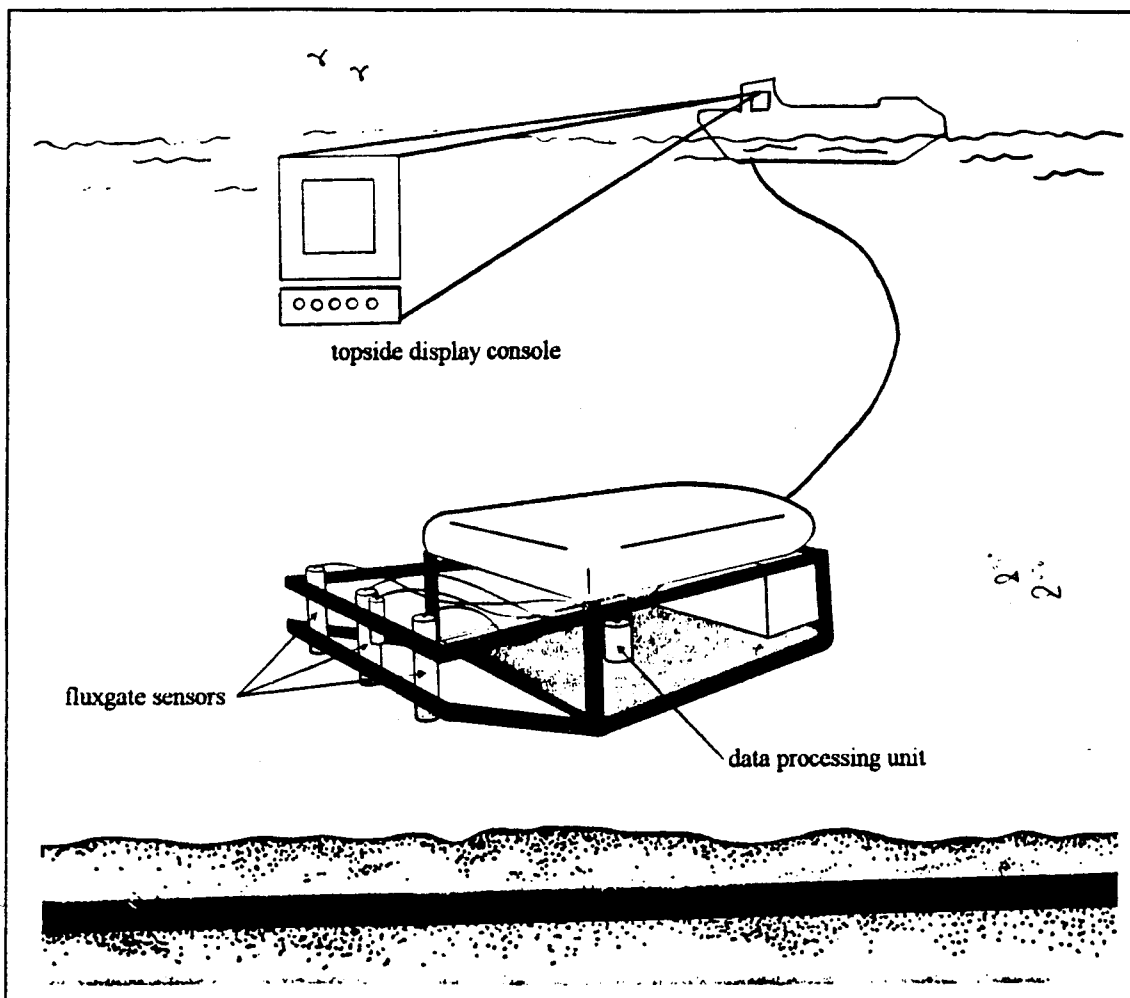

Figure 6-4. Gradiometer array schematic.

The proton precession magnetometer measures the total magnetic field intensity using the precession of spinning protons or nuclei of the hydrogen atom in a sample of hydrocarbon fluid such as kerosene or alcohol. The sensor for a proton precession magnetometer consists of a cylindrical container for the hydrogen-bearing fluid, with a wire coil inside which generates a magnetic field by passing current (Trabant 1984). When a current is applied and a magnetic field produced, the protons of the hydrogen fluid molecules align with the generated magnetic field. After the current in the coil is turned

off, the protons will *precess*, or realign themselves with the ambient (earth's) magnetic field. The precessing protons will generate a small signal with a frequency proportional to the earth's magnetic field in the coil that was used to polarize them (Thomson 1993).

Proton precession magnetometers are relatively simple in operation since they contain no moving parts, but they also provide no sense of direction (Bickham 1988). JW Fishers sells a relatively inexpensive towed unit for \$6,495, but it cannot determine the cable position relative to the fish. Instead, an experienced operator must interpret the pattern of the magnetic measurement display on either a video monitor or printer. Once the operator judges from the shape of the magnetic signal that the magnetometer is over the cable, the navigator fixes the position of the vessel. By taking fixes from the opposite direction and averaging the coordinates, the operator can estimate the cable position.

Optically pumped magnetometers are based on the atomic sublevel separation in a gas caused by the earth's magnetic field. In the sensor, the gas atoms (either cesium, rubidium, or metastable helium) are raised to their excited state by absorbing energy from an applied light source. The precession frequency is then detected as they precess back to the ground state in the presence of an ambient magnetic field. This sensor has a high sensitivity of 0.005 gamma, however, it is not completely omnidirectional and exhibits dead zones and heading errors (Milne 1980).

Proton precession and optically pumped magnetometers are not assessed in this report because the NFESC ruled them out for UCT use in their 1993 study of metal locating systems. These systems require specialized training, and previous units used in the past by Navy Underwater Demolition Teams (UDTs) and Explosive Ordnance Disposal (EOD) divers were found to be difficult to keep operating (Thomson 1993).

### **6.3.2 Acoustic Cable Markers**

A major obstacle in determining the location of cables is due to the process of self-burial. Self-burial is difficult to quantify since it is not well understood, but it results basically from the complex interaction between soils, structures, and ocean hydrodynamics. The three mechanisms which cause self-burial are localized scour and deposition from the disturbance of the cable, regional scour and deposition which is a function of regional geography and wave-current climate, and soil liquefaction (Farrier, Foda, and Bea 1989). Self-burial occurs mainly in cohesionless, or sandy type soils. Figure 6-5 is a sketch of the three-dimensional scour process and self-burial.

Acoustic cable markers are a method for marking cables which have undergone self-burial. Underwater acoustic marking devices are used in a variety of applications: underwater navigation, aids to positioning offshore structures at specific locations, and marking or tracking underwater objects and locations such as pipelines, moorings, ROVs,

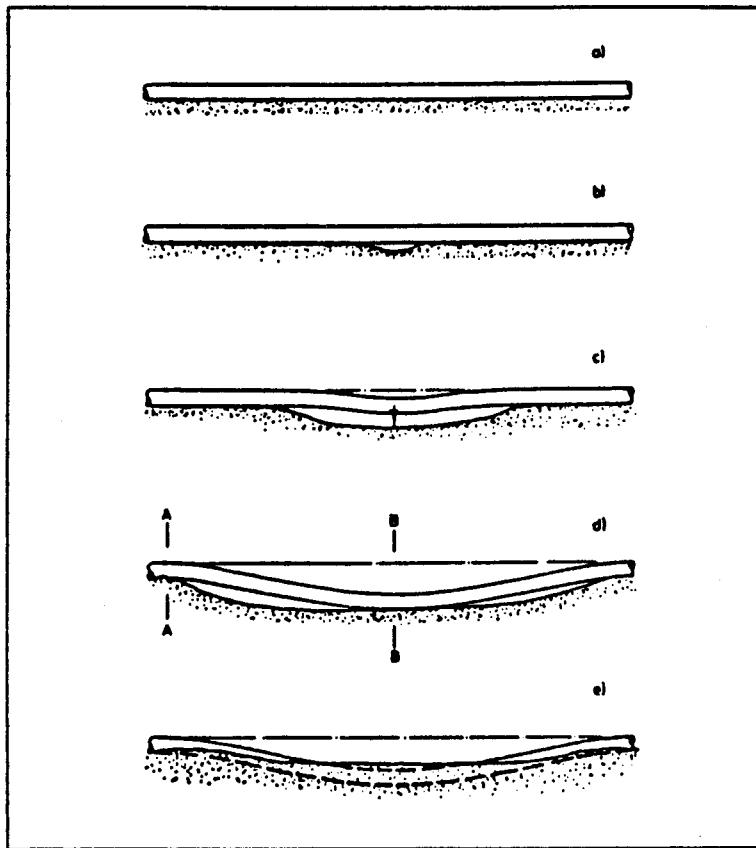

Figure 6-5. Sketch of three-dimensional scour process and self-burial (Mao 1986).

pipeline pigs, or divers. There are several different types of acoustic marker units

available:

- a) Transducer: a transmitter/receiver which sends out an interrogation signal on one frequency and receives a reply on a second frequency.
- b) Transponder: a receiver/transmitter which, on receipt of an interrogation signal on one frequency sends out a reply on a second frequency.
- c) Beacon/pinger: a transmitter which continually sends out a pulse on a particular frequency.
- d) Hydrophone: a directional or omnidirectional receiver which is capable of receiving a reply from either a transponder or a beacon.

Since inspections are conducted at intervals as long as every five years, one of the limiting factor on using underwater acoustic devices is battery life. Taking battery life and cost into account, the beacon/pinger acoustic marker is the best unit for marking underwater cables. Transponders can also be used to mark cables, but they are typically 2-3 times more expensive than pingers (O'Bannon 1994). Long life pingers are commonly configured for a three year life, emitting one pulse every second, however, pingers can be configured to a user's application. By changing the pulse rate to every two seconds, the life of the pinger can be doubled to six years. The main components of a pinger are the transducer, or antenna, electronics, and battery pack which are all encased in a pressure-proof housing. The pinger would be attached either directly to the cable, or anchored next to the cable. A typical pinger is illustrated in Figure 6-6.

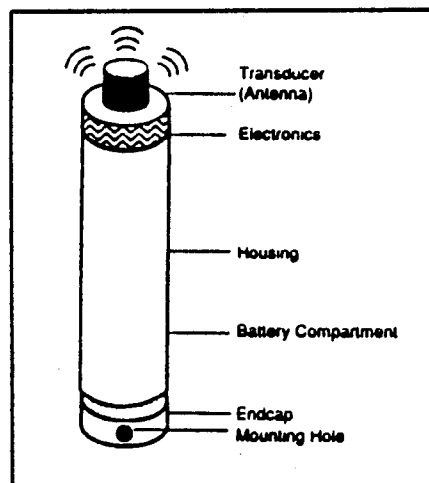

Figure 6-6. Anatomy of a pinger (Datasonics product literature 1994).

The repetitive, omnidirectional pulsed signal emitted from a pinger can be detected and homed in on from any direction using a hydrophone receiver. The hydrophone receiver can be hand-held by a diver, or held into the water from the boat by a staff. The

diver/operator tunes into the frequency of the pinger and scans the area by moving the unit through the water while listening for the pinger's signal heard through earphones. Once a signal is detected, the operator moves in the direction of the strongest signal. The earphones for a diver are bone conduction earphones. A typical hydrophone receiver is shown in Figure 6-7 in the surface deployed mode.

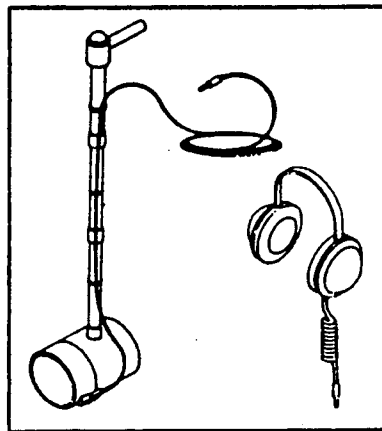

Figure 6-7. Hydrophone receiver in surface deployed mode (Datasonics product literature 1994).

The range at which a pinger can be detected will depend on the frequency and acoustic power output. The lower the frequency and the higher the output, the further the distance that a pinger can be detected. For maximum battery life, many long-life pingers operate with a 1/8 watt power output. For common pinger frequencies from 10 to 60 kHz, the range of signal detection is about 3/4 nautical miles (O'Bannon 1994).

### 6.3.3 Visual Cable Markers

The visual cable markers proposed here for passive cable location consist basically of plastic floats to provide a larger visual target for either seeing the cable, or for marking the location where the cable is buried. The floats could be installed in addition to, or instead of the brass markers every 100 feet. The floats or buoys could either be attached directly to the cable, or to a dead weight anchor. The float's position would be observed by the divers using visual location techniques such as the circling method.

Attaching the float directly to the cable provides more accuracy in locating buried cables, but it also has several disadvantages. Since the cable can bury itself to 10 feet over the years, a long "leash" would be needed on the float. This increases the possibility that the float could be snagged by fishing gear. Additionally, if the floats were to become entangled in fishing gear, the cable would then also become entangled. The dead weight anchor is a safer option for marking the cable. Dead weight anchors are reliable, simple in construction, and require no setting distance. The many varieties of anchors are shown in Figure 6-8.

### 6.3.4 Passive Cable Location Assessment

**Reliability of technology.** Gradiometers have been shown to work reliably in practice. Many companies routinely use the gradiometer to locate pipelines and cables. AT&T uses

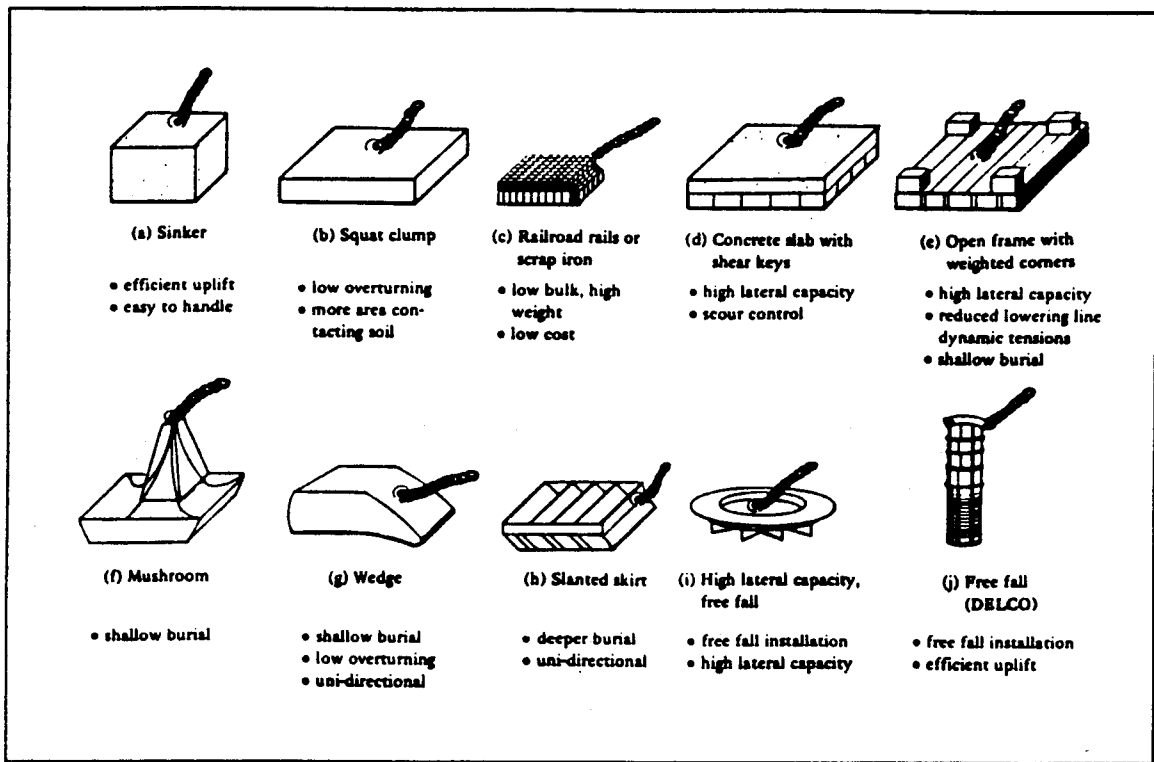

Figure 6-8. Deadweight anchors (Taylor 1982).

a multiple function system with a gradiometer array mounted on an ROV to locate telecommunication cables for splicing and repair. Pingers and buoys have also proven reliable, though for the application described above to mark cables, the reliability of the system has not been tested and is not known.

- Magnetometers/gradiometers: same
- Acoustic cable markers: NEI
- Visual cable markers: NEI

**Quality of results.** For exposed cables, the passive cable location methods would provide the same quality of results as the current practice. For buried cables and pipelines, the gradiometer array would provide an advantage since it has proven to be very effective in locating metal objects. In a 1988 study in the Gulf of Mexico sponsored by Shell Oil Co.

and Shell Pipe Line Corp., the gradiometer array was successful in locating pipelines buried at depths of 5.2 meters (Bickham 1988). Pingers and cable markers could also potentially provide better results for cables which are buried.

	<u>exposed</u>	<u>buried</u>
Magnetometers/gradiometers:	same	+
Acoustic cable markers:	same	+
Visual cable markers:	same	+

**Time.** Launch and retrieval of a gradiometer array requires care and is more time consuming than deploying the current equipment. For exposed cables, therefore, a gradiometer array would not provide a time savings. The gradiometer array would provide a time savings in locating buried cables. Once the location of the cable is known, surveying the one nautical mile length of the cable would be relatively quick work. The pingers and cable markers would save time in cable location by making the cable's location more obvious. The pinger saves time in cable location in several ways. Besides leading the inspection team directly to the cable, the pinger eliminates the need for using shore based survey stations or GPS for establishing an initial starting point to look for the cable.

	<u>exposed</u>	<u>buried</u>	<u>time for survey</u>
Magnetometers/gradiometers:	-	+	+
Acoustic cable markers:	+	+	+
Visual cable markers:	+	+	same

**Cost.** For the gradiometer array, this category represents one of the biggest drawbacks. Most of the systems available come with computers and sophisticated software to make

the output easy to interpret. Innovatum makes a multi-tracking system which can locate and track cables either passively or actively, at a system cost of \$285,000 (Innovatum 1993).

The acoustic pingers and plastic floats are considerably less expensive. A hydrophone receiver for either the hand-held or surface deployed modes can be purchased for approximately \$3,500, while the pingers themselves are about \$1,000 each. Plastic floats ranging in size from 8 to 20 inches in diameter are very inexpensive, varying from \$30 to \$200 each. The number of pingers needed depends on whether the cable is buried or exposed. If exposed with a long enough lead to eliminate self-burial, only one pinger would be needed to locate the cable. Buried cables would require pingers at established intervals along the length of the cable for an accurate survey. The number of plastic floats would likewise depend on whether the cable is located on a hard, rocky bottom or a soft bottom where self-burial is likely to occur.

Magnetometers/gradiometers: -  
Acoustic cable markers: +  
Visual cable markers: +

**Durability.** The basic dive gear currently used by the Teams will be more durable and most likely require less maintenance than a gradiometer array. The fluxgate sensors making up the array and the subsea electronics container have a durable design, but they would be subject to much abuse during launch and retrieval. The system also consists of somewhat delicate components such as the deck data processing unit and deck computer with monitor. These pieces of equipment are not as rugged. Acoustic pingers and plastic

floats are very durable items. The chains connecting them to the dead weight would need to be replaced after several inspection cycles due to corrosion.

Magnetometers/gradiometers: -  
Acoustic cable markers: same  
Visual cable markers: same/+

**Affected by weather.** The gradiometer array is more sensitive to weather conditions than current methods in several ways. If deployed from an ROV, launch and retrieval of the array and ROV are highly dependent on weather. When waves are big, the boat becomes too unstable for launching or retrieving the ROV without damage from hitting the side of the boat. Launch and retrieval is easier if the gradiometer array is mounted on a sled base, but it is still sensitive to rough weather. The acoustic cable markers and visual cable markers are subject to the same weather limitations as the current practice since they both require a diving platform from which to operate.

Magnetometers/gradiometers: -  
Acoustic cable markers: same  
Visual cable markers: same

**Dependence on visibility.** Since magnetometers operate by sensing variations in the earth's magnetic field, they are not dependent on visibility. Acoustic cable pingers likewise are not dependent on visibility. Physical cable markers would provide a more obvious target for seeing the cable, but they are still dependent on visibility.

Magnetometers/gradiometers: +  
Acoustic cable markers: +  
Visual cable markers: same

**Manpower.** The manpower required for the gradiometer array is comparable to a minimum diving crew of five for the current practice. The gradiometer array requires several people working in a coordinated effort to operate. If deployed on an ROV, the manpower required would be the ROV pilot, a gradiometer array operator, a winch operator to manage the ROV umbilical, a ship helmsman, and a surveyor. A crew supervisor would also be advisable. An ROV pilot would not be required if the gradiometer array were deployed from a sled base, but winch operation becomes critical since the depth changes considerably in the nearshore area. Manpower requirements for the pingers and cable markers are the same in that two divers at a time search for the cable, but overall, the manpower requirement is less if the cable is found using fewer dive teams.

Magnetometers/gradiometers: same  
Acoustic cable markers: +  
Visual cable markers: +

**Training.** If the gradiometer array is deployed from an ROV, training is required to pilot the ROV. The training required to interpret the readout from a gradiometer array depends on the type of deck unit used for the output. Sophisticated software programs are available which are extremely user-friendly and need little training. Compared to a year of dive training, however, a gradiometer array would require less training overall for operation. The pinger/hydrophone receiver requires some basic skill for operation, but training is minimal.

Magnetometers/gradiometers: +  
Acoustic cable markers: same  
Visual cable markers: same

**Safety.** The passive cable location methods are meant to increase safety by either keeping the divers out of the water as in the case of using a gradiometer array, or by decreasing the amount of time divers are in the water searching for cables.

Magnetometers/gradiometers: +

Acoustic cable markers: +

Visual cable markers: +

**Portability.** Deploying a gradiometer array from an ROV provides on-bottom control and a means for keeping the sensor within 10 feet of the seafloor, but it then becomes a less portable system. With the sensors located several feet apart, the ROV for this application would need to be large and have enough power to maneuver a seven to eight foot wide frame. Additionally, a large ROV ordinarily requires an A-frame piece of equipment for keeping the ROV from slamming into the side of the boat during launch and retrieval. Thus the size of the ROV needed to deliver the gradiometer array makes this option very unattractive for the UCTs.

Operating a gradiometer array from a sled base is somewhat more feasible, but still not very portable due to the size of the array frame. As mentioned earlier, the gradiometer array system also consists of many components. The computer components would need to be crated and packed very carefully to avoid damage. Overall, a gradiometer array system is complex and not very portable. Likewise, operation of a gradiometer array from a small diving platform such as a zodiac boat would not be possible due to the size of the frame for the array.

The initial installation of the pingers or hydrophone would require some effort because of the dead weight anchors, but once installed, plastic floats would require only the basic dive gear, while the pinger signal would be detectable with just the hydrophone receiver. Hydrophone receivers for detecting pingers are very portable, weighing about five to ten pounds in air, or less than one pound in water.

Magnetometers/gradiometers: -  
Acoustic cable markers: same  
Visual cable markers: same

**Ease of use.** The gradiometer array is not an easy to use system for many of the reasons discussed earlier. The system has many components, launching the equipment is more difficult, and the sensors must be kept close to the seafloor to be effective. On the other hand, detection of pingers with earphones, or looking for plastic floats are simple procedures.

Magnetometers/gradiometers: -  
Acoustic cable markers: same/+  
Visual cable markers: same/+

#### **6.4 Remotely Operated Vehicles**

Remotely operated vehicles (ROVs) are basically robots designed for the underwater environment. ROV use in the marine industry has grown steadily since its commercial introduction. In the mid 1970s, there were a handful of ROVs in operation;

by 1993 the number had grown to over 3,000 commercial and military ROVs worldwide (Westwood 1993). This is not surprising given some of the advantages ROVs offer:

- a) Operation in hazardous conditions
- b) Continuous operation
- c) Permanent video record of inspection
- d) Deeper than diver depth capability
- e) Control by non-diver inspection engineer with engineering expertise
- f) Ability to maneuver in high currents

Due to the hazardous nature of underwater operations and the physiological demands imposed on a diver, there is the tendency to want to remove divers from the water at first opportunity and replace them with some form of automatic or remote equipment. When ROVs were first introduced into diving operations, divers perceived them as a threat to their livelihood. Today, many divers still have a basic fear of obsolescence. This is unfortunate, because ROVs can be used successfully to aid divers, and make their work easier and safer. Even with the advantages ROVs offer and the continuing advancements in capability, ROVs are still low dexterity machines when compared to divers. The best solution in this struggle between man and machine is to strike a balance and combine man's dexterity with the advantages of the ROV.

#### **6.4.1 ROV Types**

There are four basic types of ROVs, with over 60 manufacturers available worldwide (Westwood 1993):

- a) free-swimming, tethered

- b) bottom-crawling, tethered
- c) towed
- d) untethered

Performance capabilities and designs of ROVs vary widely. ROVs are available in a wide variety of sizes and shapes, ranging from lightweight, inspection only "eyeball" vehicles, to 10-ton heavy work systems which operate at 20,000 foot depths. ROVs are typically designed with a general application in mind, which the user then tailors to specific needs with different tools and equipment such as manipulators, cameras, sonars, etc. The UCTs currently have two ROVs available for mission support. These vehicles are tethered, free-swimming type ROV systems, capable of supporting tasks in temperate, tropic, and Arctic environments. Tables 6-2 and 6-3 (from revised NAVFAC P-990 manual) summarize characteristics of the ROVs.

The smaller ROV, MiniROVER MKII, is manufactured by Benthos. Depending on sea conditions, it can be deployed and recovered by hand with one or two people. An important criteria for ROVs used with divers in the water is a ground-fault detection circuit. One drawback to the MiniROVER MKII is that it cannot be used interactively with divers in the water since it is not equipped with electrical safety circuits. Divers must maintain at least five feet of clearance from the vehicle while in the water (NAVFAC P-990 1994).

The second ROV available for UCT use is a Phantom DHD2+2 which is manufactured by Deep Ocean Engineering in San Leandro, California. It is much more

TABLE 6-2

## UCT ROV SYSTEM SPECIFICATIONS

	MiniROVER MK II	PHANTOM DH2+2
Vehicle		
Maximum depth (ft)	600	2000
Size (in.)	34 x 19 x 16	60 x 30 x 30
Air weight (lb)	75	20-325
Forward thrust (lb)	22	100-200
Propulsion	horizontal, lateral, vertical	horizontal, lateral, vertical
Manipulator functions	one	three
Payload (lb)	12	75-100
Camera	color pan/ tilt	color tilt
Lamps (watts)	2 at 150	2 at 150 + camera
Umbilical length (ft)	500	500-2,000
Spare conductors	2	8
Power requirements	120/208 VAC, 50/60 Hz, 1.5 kW	120/240 VAC, 50/60 Hz, 4.5 kW
Recommended crew	2-3 persons	3-4 persons

Source: NAVFAC P-990 Manual 1994

TABLE 6-3

## SHIPPING REQUIREMENT COMPARISON

Vehicle	No. Boxes	Shipping Weight (lb)	Ship Cube (cu ft)
MiniROVER	4	875	77 <sup>a</sup>
PHANTOM minimum	6	1,220	116 <sup>b</sup>
PHANTOM complete	11	2,600	212 <sup>a</sup>

Source: NAVFAC P-990 Manual 1994

<sup>a</sup> Does not include surface or sub-surface navigation system.<sup>b</sup> Assumed on-site power available, no generator shipped, and 500-foot umbilical.

powerful and versatile than the MiniROVER MKII, but it is also much larger in size and requires a minimum of four people to carry it. The Phantom is equipped with electrical safety equipment and can therefore be used for diver in-water interaction (NAVFAC P-990 1994).

The ROVs are relatively new pieces of equipment for the UCTs. At the present time, the ROVs are used mainly for special taskings and missions, and are not used for cable inspections. Whether or not ROVs are integrated into routine activities depends on several factors. The first factor is the ease of ROV operation. Unless ROVs are relatively easy to operate and integrate into routine activities, divers will conduct inspection activities "the way they have always been done." Another factor is cost effectiveness. ROVs have already shown great advantages in deep water operations where diving activities are limited; the next challenge for ROVs is economic operation in shallow waters. Generally, divers have been considered more reliable, cost effective, and efficient than ROVs in waters depths up to about 150 feet.

#### **6.4. ROV Assessment**

For many of the criteria below, the ROV is rated the same as current location and inspection methods because by itself, an ROV is simply a mechanical replacement for the divers eyes. To accomplish more than this, the ROV must be equipped with tools, or used in conjunction with the cable location methods previously assessed.

**Reliability of technology.** In the 1970s, getting an ROV to operate at 300 feet for more than an hour was a major achievement. ROVs have improved significantly in reliability and utility since then. Development has been very rapid, with color and low light level CCTV, precision locating and navigation systems, spatially correspondent and force feedback manipulators, fiber optic data transmission, cage development, and a number of other refinements. While ROVs can be operated as reliable pieces of equipment, they are still complicated systems that are not foolproof. The reliability achieved with the system depends in large part on the technical knowledge and troubleshooting abilities of the operator.

ROV (for location): -

ROV (for inspection): -

**Quality of results.** For an exposed cable, a small ROV equipped with a camera, such as the MiniROVER, could be employed both to initially locate the cable and to view the general condition of the cable for a Level I inspection. If the cable were buried, an ROV with camera alone could search for the cable if it were marked with floats, otherwise it would need to be equipped with either a hydrophone receiver to be directed to a pinger, or a more sophisticated locator tool such as a magnetometer or gradiometer array. In these cases, a larger ROV would be needed with higher thrust and payload to carry and maneuver the tools.

Regarding inspection, the condition of cables can be viewed topside through a camera on the ROV. The camera pan capability allows the viewer to see about 20 feet on

either side of the ROV, and the tilt capability provides directional viewing without maneuvering the ROV. While the results achieved by viewing the cables through the ROV camera may be adequate, seeing the cables firsthand provides higher quality results. The actual cable, and not a two-dimensional picture, can be inspected. Seeing with the eyes also provides depth perception since vision is stereoscopic.

	<u>exposed</u>	<u>buried</u>
ROV (for location):	same	same
ROV (for inspection):	-	same

**Time.** The time required to locate and inspect an exposed cable using a small camera ROV would generally be about the same as the time for divers to locate and inspect a cable, as this involves the same visual work. The ROVs operate at a speed of approximately 3 knots. Launching a small ROV is relatively quick and easy with one to two people -- no additional overboarding hardware is needed. Performing simple inspection tasks with an ROV, however, can be more time consuming in many cases. For instance, noting position along the length of the cable (where a repair is needed) using a brass tag could be more difficult and time consuming for an ROV if the tag is turned over, or if the tag number is obscured by marine growth. A diver would quickly and easily be able to turn the tag over and scrape off the growth. Using an ROV would take more time, and the ROV would need a special "grabber" and "scraper" type attachment to accomplish this task.

For a buried cable, the ROV by itself would not be able to locate the cable any quicker unless the cable were marked, or the ROV were equipped with special locator tools. Again, having tools equates to a larger ROV, which also involves a more time consuming launching procedure.

	<u>exposed</u>	<u>buried</u>
ROV (for location):	same	same
ROV (for inspection):	-	same

**Cost.** There is a wide range in size and price of ROVs. ROVs are available today at extremely low prices. Some can be purchased for as low as \$5,000 to \$6,000. These are generally considered “toys” in the industry because they have enough power to pull the cable behind them, but not much else. ROVs which are powered enough to be useful for the UCTs cost on the order of \$20,000 and up (Ballou 1994). The basic miniROVER MK II costs \$51,400 (Moller 1994). This price includes the control console, cable, and camera. The cameras installed on ROVs are typically wide-angle cameras which have a lens viewing angle of just under 90° horizontally, and slightly less than 60° vertically. The ROV in itself, however, will generally not be useful without being equipped with some basic sensors and tools. For example, once the ROV is in the water, its position must be known in order to accomplish any survey work. This can be accomplished with a tracking system. The tracking system will generally cost about \$15,000 to \$20,000. Some of the tools that the ROV can be equipped with are “grippers” and “grabbers” which cost around \$5,000 to \$6,000 each (Ballou 1994). Another useful sensor for low visibility conditions is a scanning sonar which costs about \$15,000 to \$20,000. The above items are easily

obtainable, off the shelf type items. Other equipment which is more exotic would need to be specially made. Overall, the ROV is a more expensive option than outfitting divers.

ROV: -

**Durability.** ROVs are built to withstand the harsh marine environment. Yet when compared to basic scuba dive gear, ROVs are not as durable. ROVs are more fragile, and must be packed carefully for shipping in order to avoid damage.

ROV: -

**Affected by weather.** ROVs are more vulnerable to rough seas during their launch and recovery, but an advantage of using ROVs over divers is that ROVs are not limited by the temperature of the water. ROVs can operate continuously without tiring or being affected by the cold. In this sense, ROVs are less affected by weather.

ROV: +

**Dependence on visibility.** The ROV camera depends on good visibility the same as a diver if searching for a cable or inspecting one, however, the camera on an ROV can operate at low light levels. If equipped with a scanning sonar, the ROV would be able to "see" the cable for the purposes of surveying its location independent of visibility, but the image would not be adequate for viewing the general condition of the cable.

ROV: +

**Manpower.** Overall, ROV operations require less personnel and support equipment than do manned diving operations. ROV operations require an ROV pilot, a winch operator to

manage the tether or umbilical, ship helmsman, and someone to mark position fixes.

ROVs do not tire, and can be operated continuously without needing a surface interval to allow residual nitrogen out of the system as divers do.

ROV: +

**Training.** Learning to maneuver an ROV takes skill and practice. ROVs require training in both operation and maintenance. In addition, the success of ROV operation will depend on the experience and troubleshooting skills of the operator. Yet, when compared to the year of diving instruction, ROV operation requires less training overall.

ROV: +

**Safety.** Since ROVs keep divers out of the water, cable inspections using ROVs are safer.

ROV: +

**Portability.** The basic ROV system consists of: (1) vehicle with camera, lamps, thrusters, compass, depth gauge, and ballast/floatation; (2) control console; (3) viewing monitor; (4) power transformer; (5) generator; and (6) umbilical cable. Overall, ROV operation does not require as much equipment as the current inspection practice. Keeping divers out of the water also eliminates the need for a compression chamber.

ROV: +

**Ease of use.** For the ROV to be compatible with the UCTs, it must be easy to use.

Otherwise, divers are likely to abandon ROVs for the old, familiar methods. ROVs are rated lower here than the current practice due primarily to umbilical management, which is

the most difficult part of using an ROV. The umbilical must be handled carefully to avoid entanglement in the ship's propellers or on objects on the seafloor. Entanglement usually results from too much umbilical in the water. The amount of umbilical in the water must also be managed to avoid excessive drag from the umbilical.

ROV: -

## CHAPTER 7

### SUMMARY AND CONCLUSIONS

Cable inspections can be improved during several stages: determining the initial position for cable location and surveying, locating cables, and inspecting cables. This report presented an overview of various equipment and practices which could be used in the marine environment for cable location and inspections. Each alternative was evaluated on a number of criteria. Table 7-1 presents a compilation of the alternatives which were assessed.

As mentioned previously, the plus and minus signs cannot be simply added up at the end of each column since the criteria are not weighted equally. Yet, the table does point out certain trends with each option. In general, the alternatives can be classified into one of three categories:

- (1) Technology which is not promising at this time.
- (2) Technology which may be promising, but for which more information is needed.
- (3) Technology which is promising.

TABLE 7-1

OVERALL ASSESSMENT

CRITERIA	Initial Position	Cable Location										Inspection			
		side scan sonar	sub-bottom profiler	radar	magneto-grammeters	acoustic cable markers	visual cable markers	ROV	replace-ment/maint.	self-inspecting	improved siting	ROV	replace-ment/maint.	self-inspecting	improved siting
Reliability of technology	GPS	same	same	-	same	NEI	NEI	NEI	NEI	NEI	NEI	-	NA	+	NA
Quality of results		same	+	-	+	-	+	+	+	+	+	same	NA	-	NA
Time		same	same	NEI	same	same	same	same	same	same	same	-	NA	-	NA
Time for survey		+	+	-	+	-	+	+	+	+	+	same	NEI	-	NEI
Equipment Cost		same	+	NEI	+	+	+	+	+	+	+	same	NEI	-	NEI
Durability		+	-	-	-	-	+	+	+	+	+	-	-	-	NEI
Affected by weather		same	-/same	NEI	-	same	same	same	same	same	same	-	NA	+	NA
Dependence on visibility		+	same	same	-	same	+	+	+	+	+	+	NA	+	NA
Manpower		+	same	same	+	NEI	+	+	+	+	+	+	NEI	-	NEI
Training		+	+	NEI	+	+	+	+	+	+	+	+	NA	NEI	NA
Safety		+	+	NEI	+	+	+	+	+	+	+	+	NEI	+	NEI
Portability		+	+	NEI	-	+	+	+	+	+	+	+	-	+	NA
Ease of use		+	-/+	NEI	-	+	+	+	+	+	+	-	NA	+	NA

Dual symbols are used where a comparison is made between a diver visually locating cable or using cable location tools  
 + : Rated higher than datum - : Rated lower than datum same: Rated the same as the datum  
 NA not applicable  
 NEI not enough information available

The first category, technology which is not promising for UCT use, includes radar, self-inspecting cables, cable replacement, gradiometers, side scan sonar, and sub-bottom profilers. Radar is not promising because at this time, the resolution is not good enough to locate cables. Cable replacement, self-inspecting cables, and gradiometers are not practical for the UCTs mainly due to cost. The gradiometer could potentially be a useful tool for the UCTs if a feasible deployment method is devised, such as a sled base which is not too cumbersome. Side scan sonar and sub-bottom profilers are included in this category because although they do have some advantages over the current practice, they are also accompanied by an equal number of disadvantages. At this time, there are not enough reasons to incorporate the side scan sonar or sub-bottom profiler into current practice. As the technology improves, and perhaps the price on some of the equipment comes down, the technology may be useful in the future.

The second category, technology which may be promising, but for which more information is needed, is most applicable to cable siting. Improved cable siting could be beneficial in reducing wear and tear and extending the life of cables installed in the future. However, if it is necessary for the cable to be installed in a particular location which is very harsh, even the best route for the cable in that location may not protect the cables. More information on the cost and the manpower required is needed to evaluate this option further.

Technology which falls into the promising category includes GPS navigation equipment for initial position determination and surveying, acoustic and visual cable markers for cable location, and ROVs for cable inspection. GPS, acoustic, and visual markers were rated the same or better than current practice for every criterion. In looking at the + and - trends in table 7-1, it is not obvious that ROVs are promising while other technologies such as side scan sonar, sub-bottom profilers, and gradiometer are not promising. The main reason ROVs are considered promising is that they can be used for both cable location and inspection, while the other technologies mentioned are only for cable location. Furthermore, being a self-propelled unit, an ROV can be controlled much more than the devices which are deployed from a towfish.

This report has laid the groundwork for improving cable inspections by reviewing and assessing available technology for cable inspections in terms of the factors listed in Table 7-1. Improving the efficiency of cable inspections allows the UCTs to keep up with their expanding workload, and perform inspections using fewer resources. Recommend more in depth study of the promising options. Since ROVs are already owned by the UCTs, the focus should be on GPS, and acoustic and visual cable markers. These are relatively low cost options that could be implemented on a trial basis with little additional resources.

## REFERENCE LIST

- Abrams, William R. 1990. Side Scan Sonar Advances With On-line Processing. Sea Technology (February): 47-48.
- Ballou, Philip J., Senior Vice President of Deep Ocean Engineering. 1994. Phone conversation on 7 November.
- Bayliss, M., Short, D., and M. Bax. 1988. Underwater Inspection. San Pedro, CA: Best Publishing Company.
- Bea, R.G. 1994a. Construction, Maintenance and Design of Marine Structures and Foundations, CE 180-NA156 class reader. University of California at Berkeley.
- \_\_\_\_\_. 1994b. Reliability Based Criteria for Design and Maintenance of Marine Structures. CE 290A-NA290C class reader. University of California at Berkeley.
- Bennett, Verne. 1991. No Need for Peacetime Selective Availability. GPS World (September): 48-51.
- Berian, Albert G. 1994. Maximizing, Predicting In-Situ Cable Life. Sea Technology 35, no. 7 (July): 49-50.
- Bickham, K.L. 1988. Tests Evaluate Equipment to Locate Subsea Lines. Oil & Gas Journal (June 6):60-64.
- Black, Stanley A. 1986. A History of Navy Underwater Construction. Unpublished Paper.
- Buffkin, Mark D. 1990. Inspection and Monitoring of Marine Structures. Master's Report, University of California at Berkeley.
- Farrier, Joel B., Mostafa A. Foda, and Robert G. Bea. 1989. Evaluation of the Potential for Self-burial of the Proposed Unocal Gina Pipeline. Berkeley, California: Hydraulic and Coastal Engineering Division of the Department of Civil Engineering, University of California at Berkeley.

Fox, Christopher G., Robert P. Dziak, Haruyoshi Matsumoto, and Anthony E. Schreiner. 1993. Potential for Monitoring Low-Level Seismicity on the Juan de Fuca Ridge Using Military Hydrophone Arrays. Marine Technology Society Journal. 27, no. 4 (Winter):22-29.

GPS World Receiver Survey. 1994. GPS World (January): 38-56.

Grace, Robert A. 1978. Marine Outfall Systems: Planning, Design, and Construction. Englewood Cliffs, NJ: Prentice-Hall.

Gross, Thomas. 1994. Acute and Chronic Decompression Sickness. Introduction to Scientific Diving, IDS-407 class reader. University of California at Berkeley.

Holt, Rob, Lieutenant, Civil Engineer Corps, U.S. Navy, Ocean Engineering Projects Officer. 1994. Phone conversations on 7 September and 4 November.

Innovatum. 1993. Multi System price list and product information, Innovatum, Inc.

Koppenjan, Steven and Michael Bashforth. 1993. The Department of Energy's Ground Penetrating Radar (GPR), An FM-CW System. In Underground and Obscured Object Imaging and Detection: Proceedings of the International Society for Optical Engineering Conference held in Orlando, Florida 15-16 April 1993, edited by N.K. Del Grande, I. Cindrich, and P.B. Johnson, 45-54. Bellingham, Washington: SPIE.

Langley, Richard B. 1994. RTCM SC-104 DGPS Standards. GPS World (May): 48-53.

\_\_\_\_\_. 1993. Communication Links for DGPS. GPS World (May): 47-51.

Lincoln, Walter B. 1979. Underwater Search Using Side Scan Sonar. Washington D.C.: Office of Research and Development, U.S. Coast Guard Research and Development Center. NTIS, Report No. CG-D-08-79.

Mao, Ye. 1986. The Interaction Between a Pipeline and an Erodible Bed. Ph.D. diss. (equivalent of), Institute of Hydrodynamics and Hydraulic Engineering, Technical University of Denmark (series paper no. 39).

Maser, Kenneth and W.M. Kim Roddis. 1990. Principles of Thermography and Radar for Bridge Deck Assessment. Journal of Transportation Engineering 116, no. 5 (Sep/Oct): 583-595.

Masters, George W. 1993. Navigation Systems Test and Evaluation. Patuxent River, Maryland: U.S. Naval Test Pilot School.

Milne, P.H. 1980. Underwater Engineering Surveys. Houston: Gulf Publishing Company.

- Milwee, William I. Jr. 1989. Underwater Work on America's Infrastructure. Marine Technology Society Journal 23, no. 3 (September): 21-27.
- Moller, Carl, product representative for Benthos. 1994. Phone conversation on 22 November.
- Motorola. 1994. Mini-Ranger price information and product information, Motorola Corporation.
- Myrum, Marc, Lieutenant, Civil Engineer Corps, U.S. Navy, Executive Officer UCT Two. 1994. Interview on 25 July, Port Hueneme, CA
- National Oceanic and Atmospheric Administration. 1991. The NOAA Diving Manual. Washington DC: U.S. Department of Commerce, National Oceanic and Atmospheric Administration, Office of Marine Resources.
- Naval Facilities Engineering Command. 1978. NAVFAC P-990, Conventional Underwater Construction and Repair Techniques. Alexandria, VA: Naval Facilities Engineering Command.
- Naval Facilities Engineering Command. 1994. Revised Draft: NAVFAC P-990, Conventional Underwater Construction and Repair Techniques. Alexandria, VA: Naval Facilities Engineering Command.
- Nishimura, Clyde E., and Dennis M. Conlon. 1993. IUSS Dual Use: Monitoring Whales and Earthquakes Using SOSUS. Marine Technology Society Journal 27, no. 4 (Winter 1993-1994): 13-21.
- O'Bannon, Bruce, Representative of RJE International, Inc. (company specializing in underwater acoustic locating equipment). 1994. Phone Conversation on 3 November.
- Oswald, Robert B. 1993. Dual Use Technology: Using Department of Defense Technology to Support Marine Research. Marine Technology Society Journal 27, no. 4 (Winter 1993-1994): 49-51.
- Parkinson, Bradford W. 1994. GPS Eyewitness: The Early Years. GPS World 5, no. 9 (September): 32-45.
- Receiver Survey. 1994. GPS World 5, no. 1 (January): 38-56.
- Runge, Peter K. 1992. Undersea Lightwave Systems. AT & T Technical Journal 71, no. 1 (January/February): 5-13.

- Schaaf, Terri, product representative for EG&G Marine Instruments. 1994. Phone conversation on 10 November.
- Schock, Steven G. and Lester R. LeBlanc. 1990. Chirp Sonar: New Technology for Sub-bottom Profiling. Sea Technology (September): 35-43.
- Schofield, Jim, Lieutenant, U.S. Navy, Civil Engineer Corps, Ocean Engineering Projects Officer, Naval Command, Control and Ocean Surveillance Center. 1994. Interview on 9 August, San Diego, CA.
- Taylor, Robert J. 1982. Interaction of Anchors with Soil and Anchor Design. Port Hueneme, California: Civil Engineering Laboratory. NCEL Technical Note N-1627.
- Thomson, Hugh. 1993. Diver-Operated buried Pipe and Chain Locator. Port Hueneme, California: Naval Civil Engineering Laboratory. NCEL Technical Note N-1853.
- Trabant, Peter K. 1984. Applied High-Resolution Geophysical Methods. U.S.A.: International Human Resources Development Corporation.
- UCT Two. 1984. Completion report: cable inspection @ Kauai, Hawaii. Unpublished report.
- UCT Two. 1991. Completion report: cable inspection @ Guam. Unpublished report.
- UCT Two. 1991. Completion report: cable inspection @ Coos Bay, Oregon. Unpublished report.
- Urick, Robert J. 1983. Principles Of Underwater Sound. U.S.A.: McGraw-Hill, Inc.
- US Department of Commerce, National Oceanic and Atmospheric Administration. 1991. NOAA Diving Manual: Diving for Science and Technology. United States: National Oceanic and Atmospheric Administration.
- Vogelzang, G.J., M.W.A. van der Kooij, and G. Vanderburg. 1991. Sea Bottom Topography Imaging with Polarimetric P-, L-, and C-Band SAR. In Remote Sensing: Global Monitoring for Earth Management: Proceedings of the symposium held in Espoo, Finland June 3-6, 1991, by IEEE and IGARSS. Finland: IEEE, 2031-2034.
- Wadsworth, A., J.P. Deroin, and J.P. Rudant. 1991. Imaging Radar and Offshore Geology. In Remote Sensing: Global Monitoring for Earth Management: Proceedings of the symposium held in Espoo, Finland June 3-6 1991, by IEEE and IGARSS. Finland: IEEE, 2045-2046.

Watson, Judy, Senior Technical Support for AT &T - Local Area Wide Networks. 1994.  
Phone conversation on 23 September.

Westwood, John. 1993. Man v. Machine - 10 Years On. In Subtech '93 Vol. 31.  
Netherlands: Society for Underwater Technology, 207-217.

Wilkey, P.L. 1991. Survey of the State of the Art in Near-Shore Pipeline Location and  
Burial Assessment. Argonne National Laboratory. GRI Contract Number 5088-252-  
1770.

Wysocki, Joseph, Lieutenant Colonel, U.S. Air Force. 1991. GPS and Selective  
Availability - The Military Perspective. GPS World 2, no. 7 (July/August): 38-44.