

AL/OE-CR-1994-0013

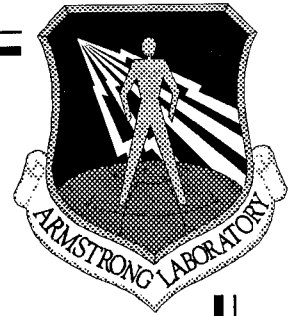

**LONG RANGE WATER PLAN
WRIGHT PATTERSON AIR FORCE BASE, OHIO
PHASE I**

Jeffrey L. Van Atten, PE
Robert E. Forbes, PE

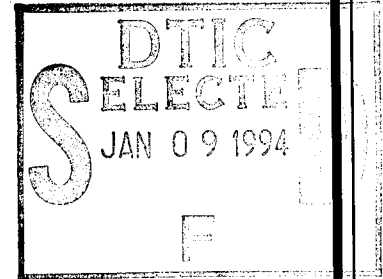

Pacific Environmental Services, Inc.
560 Herndon Parkway - Suite 200
Herndon, Virginia 22070

OCCUPATIONAL AND ENVIRONMENTAL HEALTH DIRECTORATE
2402 E Drive
Brooks Air Force Base, TX 78235-5114

APRIL 1994

Final Contractor Report for Period September 93 - April 1994

Approved for public release; distribution is unlimited.

19950105 049

1223 QUALITY INSPECTED 3

AIR FORCE MATERIEL COMMAND
BROOKS AIR FORCE BASE, TEXAS

ARMSTRONG
LABORATORY

DISCLAIMER NOTICE

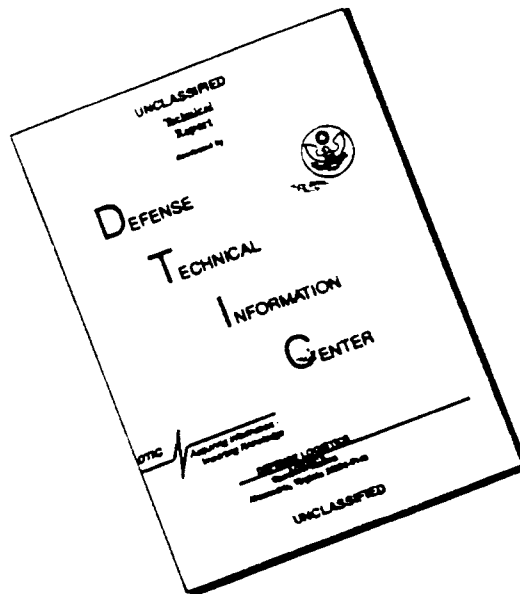

THIS DOCUMENT IS BEST QUALITY AVAILABLE. THE COPY FURNISHED TO DTIC CONTAINED A SIGNIFICANT NUMBER OF PAGES WHICH DO NOT REPRODUCE LEGIBLY.

NOTICES

This technical report is published as received and has not been edited by the technical editing staff of the Armstrong Laboratory.

Publication of this report does not constitute approval or disapproval of the ideas or findings. It is published in the interest of STINFO exchange.

When Government drawings, specifications, or other data are used for any purpose other than in connection with a definitely Government-related procurement, the United States Government incurs no responsibility or any obligation whatsoever. The fact that the Government may have formulated or in any way supplied the said drawings, specifications, or other data, is not to be regarded by implication, or otherwise in any manner construed, as licensing the holder, or any other person or corporation; or as conveying any rights or permission to manufacture, use, or sell any patented invention that may in any way be related thereto.

The mention of trade names or commercial products in this publication is for illustration purposes and does not constitute endorsement or recommendation for use by the United States Air Force.

The Office of Public Affairs has reviewed this report, and it is releasable to the National Technical Information Service, where it will be available to the general public, including foreign nationals.

This report has been reviewed and is approved for publication.

Government agencies and their contractors registered with Defense Technical Information Center (DTIC) should direct requests for copies to DTIC, Building #5, Cameron Station, 5010 Duke St., Alexandria VA 22304-2103.

Non-Government agencies may purchase copies of this report from: National Technical Information Services (NTIS), 5285 Port Royal Road, Springfield VA 22161-2103.

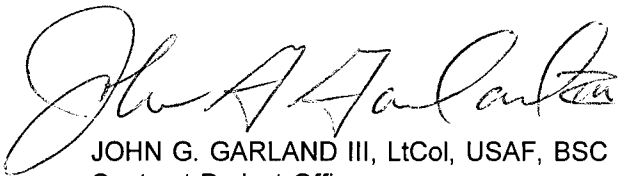
JOHN G. GARLAND III, LtCol, USAF, BSC
Contract Project Officer

JAMES D. MONTGOMERY, LtCol, USAF, BSC,
Chief, Bioenvironmental Engineering
Division

Accession for	
NTIS CB/BI	<input checked="" type="checkbox"/>
DTIC TAB	<input type="checkbox"/>
Unannounced	<input type="checkbox"/>
Justification	
By	
DTIC	
A-1	

TABLE OF CONTENTS

SECTION 1	INTRODUCTION	1-1
	General	1-1
	Purpose	1-1
	Scope of Work	1-1
	Outline of Contents	1-2
SECTION 2	BACKGROUND AND HISTORY	2-1
	History	2-1
	Environmental Setting	2-1
	Organizations	2-4
	Development	2-4
	Supply	2-5
	Treatment	2-12
	Distribution	2-16
	Storage	2-17
	Pumphouse	2-19
SECTION 3	CURRENT AND PROJECTED DEMANDS	3-1
	Existing Conditions	3-1
	Projected Demands	3-4
SECTION 4	QUANTITATIVE ANALYSIS OF SUPPLY OPTIONS .	4-1
	Groundwater	4-1
	Surface Water	4-10
	Purchased Water	4-11
	Summary	4-13
SECTION 5	QUALITATIVE ANALYSIS OF SUPPLY OPTIONS . .	5-1
	General	5-1
	USEPA-OEPA Requirements	5-4
	Treatment Issues	5-11

TABLE OF CONTENTS
(continued)

SECTION 6 **VULNERABILITY ANALYSIS 6-1**

Emergencies 6-1

Types of Emergencies 6-1

Potential Natural Disasters 6-2

Potential Manmade Disasters 6-4

Emergency Planning 6-5

Vulnerability Reduction Recommendations 6-9

Summary 6-13

SECTION 7 **RECOMMENDATIONS 7-1**

Introduction 7-1

Upgrade and Improve Existing Systems 7-1

Central Water Treatment Plant 7-4

Page Manor 7-5

Public Supply 7-5

Proposed Work Plan for Phase 2 7-5

Contract Effort and Time Schedule 7-6

LIST OF REFERENCES
LIST OF ABBREVIATIONS

APPENDIX A **MEMO FOR RECORD-MIAMI CONSERVANCY DISTRICT AND FLOODPLAN ISSUES**

APPENDIX B **EVALUATION SURVEY OF PUBLIC DRINKING WATER SUPPLY SYSTEMS, OEPA**

APPENDIX C **RESPONSE TO OEPA SURVEY COMMENTS, WPAFB**

APPENDIX D **DESIGN SCHEDULE**

APPENDIX E **WATER TOWERS/RESERVOIRS FACTS**

APPENDIX F **1993 TRIANNUAL SAMPLING RESULTS**

APPENDIX G **WEF ARTICLE ON SCHENECTADY, NY WELLHEAD PROTECTION**

LIST OF TABLES

TABLE 2-1	HISTORY OF WPAFB OPERATIONS	2-7
TABLE 2-2	WPAFB WATER STORAGE	2-18
TABLE 3-1	WATER SYSTEM FUTURE DEMAND (AREAS A AND C)	3-6
TABLE 3-2	WATER SYSTEM FUTURE DEMAND (AREA B)	3-7
TABLE 4-1	WPAFB PRODUCTION WELLS	4-9
TABLE 5-1	CONTAMINANTS REQUIRED TO BE REGULATED UNDER THE SDWA AMENDMENTS OF 1986	5-2
TABLE 5-2	OHIO MCLs FOR VOLATILE ORGANIC CHEMICALS	5-5
TABLE 5-3	OHIO MCLs FOR SYNTHETIC ORGANIC CHEMICALS	5-6
TABLE 5-4	OHIO MCLs FOR INORGANIC CONTAMINANTS	5-7
TABLE 5-5	OHIO MCLs FOR MICROBIOLOGICAL CONTAMINANTS AND RADIONUCLIDES	5-8
TABLE 5-6	OHIO SECONDARY MCLs	5-10
TABLE 6-1	INTERRELATIONSHIP BETWEEN DISASTERS AND THEIR EFFECTS	6-3
TABLE 6-2	LIQUIDS FLIGHT (AS OF DEC. 1993)	6-8

LIST OF FIGURES

FIGURE 2-1	AREA MAP	2-2
FIGURE 2-2	WRIGHT-PATTERSON AIR FORCE BASE	2-3
FIGURE 2-3	LOCATION OF PAST HAZARDOUS SUBSTANCE ACTIVITIES (AREAS A AND C)	2-8
FIGURE 2-4	LOCATION OF PAST HAZARDOUS SUBSTANCE ACTIVITIES (AREA B)	2-9
FIGURE 2-5	OPERABLE UNITS (AREAS A AND C)	2-10
FIGURE 2-6	OPERABLE UNITS (AREA B)	2-11
FIGURE 2-7	AREA "A" WATER SYSTEM SCHEMATIC	2-13
FIGURE 2-8	AREA "B" WATER SYSTEM SCHEMATIC	2-14
FIGURE 2-9	AREA "C" WATER SYSTEM SCHEMATIC	2-15
FIGURE 3-1	EXISTING LAND USE (AREAS A AND C)	3-3
FIGURE 3-2	EXISTING LAND USE (AREA B)	3-5
FIGURE 4-1	LOCATION OF GEOLOGIC SECTION	4-2
FIGURE 4-2	GEOLOGIC SECTION A-A'	4-3
FIGURE 4-3	GEOLOGIC SECTION C-C'	4-4
FIGURE 4-4	GROUNDWATER LEVELS IN THE REGION	4-5
FIGURE 4-5	GENERALIZED VERTICAL SECTION	4-6
FIGURE 4-6	WRIGHT-PATTERSON AIR FORCE BASE WATERSHED	4-7

SECTION 1

INTRODUCTION

GENERAL

Wright-Patterson Air Force Base (WPAFB) supplies potable drinking water to Areas A, B, and C from individual groundwater sources and similar treatment processes located in each Area. The Safe Drinking Water Act and related regulations promulgated by the United States Environmental Protection Agency (USEPA) and endorsed by the Ohio Environmental Protection Agency (OEPA) have placed strict requirements on the Base to assure that all consumers are provided a safe, high quality, and continuous supply of drinking water. In order to assist the Base in an aggressive and comprehensive program to fully evaluate available water supply and treatment alternatives which comply with all Federal and State regulations, Pacific Environmental Services, Inc. (PES) has been retained to prepare this Long-Range Water Plan through a contract mechanism with the United States Air Force (USAF), Armstrong Laboratory, Occupational and Environmental Health Directorate.

PURPOSE

The purpose of this Long-Range Water Plan is to define and evaluate alternatives for providing the public water systems on the Base with water that will meet future demands as well as environmental regulations. These alternatives may include treatment system upgrades, maintenance/repair of existing treatment components, or a completely new water supply. The recommended alternatives are to be based on hydrogeologic and water quality data, an assessment of the existing water supply and treatment systems, and off-Base sources of water. The positive and negative aspects of each alternative are to be described in detail. Cost estimates are to be used as needed to support a time-phased, prioritized implementation plan.

SCOPE OF WORK

The Long-Range Water Plan for WPAFB is divided into two phases:

1. Hydraulic and Water Quality Requirements Analyses
2. Detailed Alternative Analysis and Development of Long-Range Water Plan

This initial phase focuses primarily on the evaluation of future water supply demands at the Base, including both qualitative and quantitative aspects, and alternatives for meeting these needs. The evaluation includes a hydraulic analysis of the available capacity of groundwater, surface water, and feasible off-Base purchase options; an analysis of regulatory requirements and their potential impact on the quality of water to be developed and supplied at the Base; and a general vulnerability analysis of the existing systems.

In accomplishing this scope of work, PES completed the following tasks:

- Conducted a thorough survey of existing engineering and water quality documents to evaluate the existing water systems and the current condition of the water source.
- Reviewed current USEPA and OEPA requirements and contacted regulatory personnel regarding expected future regulations to evaluate if they are being or will be met.
- Reviewed current and future capacity and system demands, noting limitations and expansion capabilities/requirements associated with supply and treatment issues.
- Interviewed appropriate Base personnel to obtain additional information regarding the hydrogeology of the area, the water supply systems, existing and anticipated Base activities, and groundwater contamination.

OUTLINE OF CONTENTS

Section 2 of this report presents the background and history of WPAFB, including the existing water supply and treatment facilities. Section 3 addresses current and projected water demands at the Base. Section 4 provides a quantitative analysis of supply options, including groundwater, surface water, and purchased water. Section 5 provides a qualitative analysis of supply options. Section 6 addresses a vulnerability analysis of the existing collection, treatment, transmission, pumping, storage, and distribution facilities with respect to redundancy and emergency operation. Section 7 describes alternatives which are recommended for detailed evaluation in Phase 2, presents a proposed work plan for the completion of Phase 2 efforts, and provides an estimated cost and time schedule for the completion of the Long-Range Water Plan.

SECTION 2

BACKGROUND AND HISTORY

HISTORY

Aviation history was made on 17 December 1903 when Orville and Wilbur Wright made the first successful flights of a motor-powered aircraft at Kitty Hawk, on the Outer Banks of North Carolina. Following their initial success, the brothers returned to their home in Dayton, Ohio to devote their genius towards the development of aviation. During 1904-1905, the Wright Brothers erected the first hangar at what is now Wright-Patterson AFB and began the major work to perfect their elementary flying machines and to learn the essentials of flight.

In 1917, Wilbur Wright Field was established as a military base where the present active runway is located. Pilot training, research and development, flight testing, and depot activities took place on land leased to the government for wartime use. The Fairfield Air Depot, located in Area C, adjacent to Wilbur Wright Field, began operations in 1918 as a general supply depot and regional aircraft engine repair hub. In 1924, Dayton citizens purchased and deeded to the U.S. Government 4,500 acres of land for the creation of Wright Field in Area B. In 1931, the portion of the Base east of Huffman Dam was redesignated Patterson Field. The two fields remained separate until 1948, when they were merged to form Wright-Patterson AFB.

Figure 2-1 indicates that most of the Base is in Greene County except for the Wright Field portion of Area B and a small segment of Area C which both lie in Montgomery County. A very thin slice of the northern Base boundary extends into Clark County.

ENVIRONMENTAL SETTING

WPAFB lies in the Mad River Valley with the airfields located on the fairly flat and broad flood plain of the river as presented in Figure 2-2. The majority of the Base's buildings are sited on the gently rolling terrain in the higher elevations of the facility. Huffman Dam, located on the Mad River at the southwest corner of Area C, is an important flood control structure. The dam will back up flood waters into Areas A and C, while protecting Area B which is downstream from the dam. Elevations on the Base range from as low as 790 feet near Huffman Dam to as high as 980 feet in the southeast corner of Area B. Surface drainage runs from the east side of the Base towards the Mad River through Hebble Creek, Mud Run, Trout Run and smaller drainage channels (see Figure 4-6).

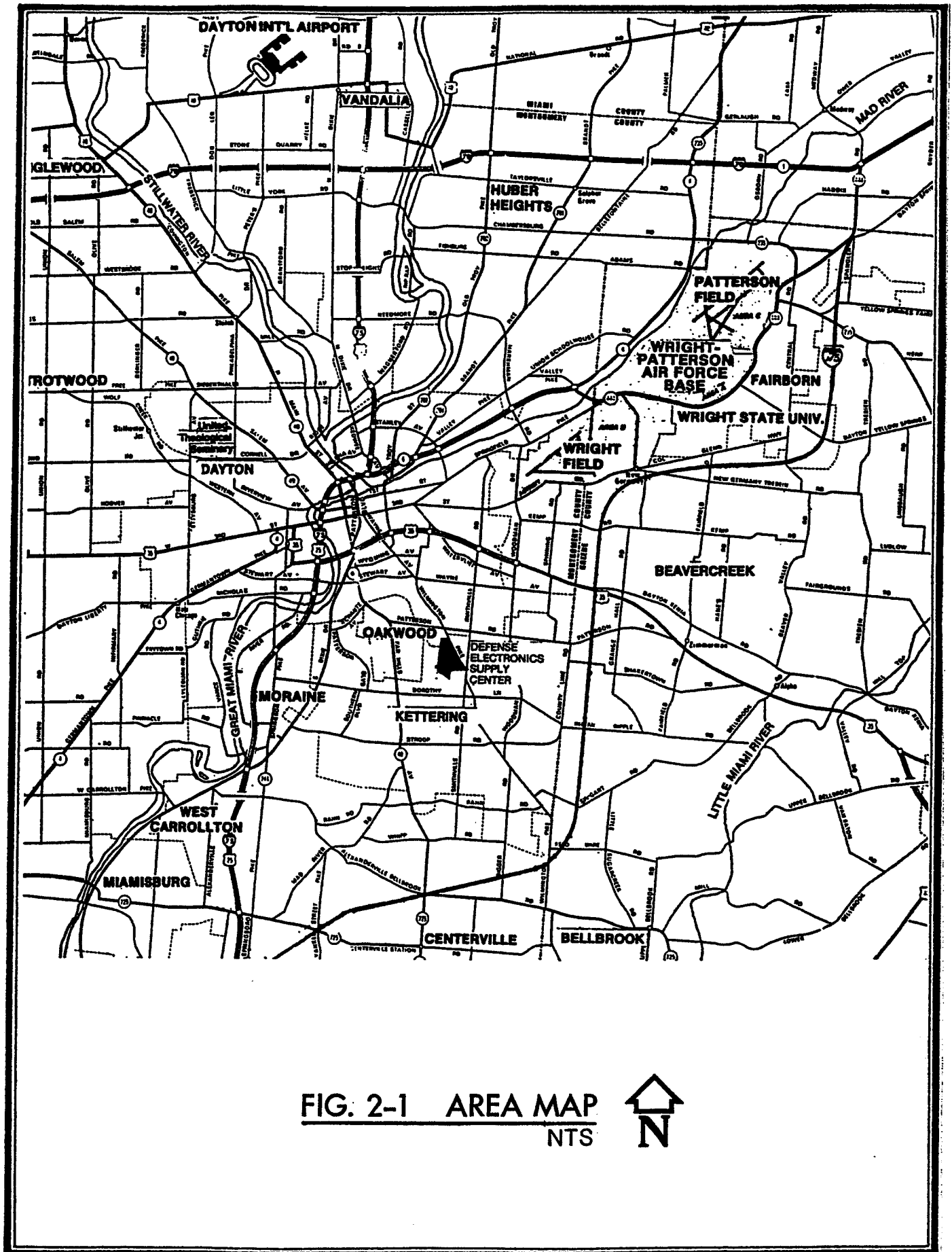

FIG. 2-1 AREA MAP
NTS





Area Location Map
NTS

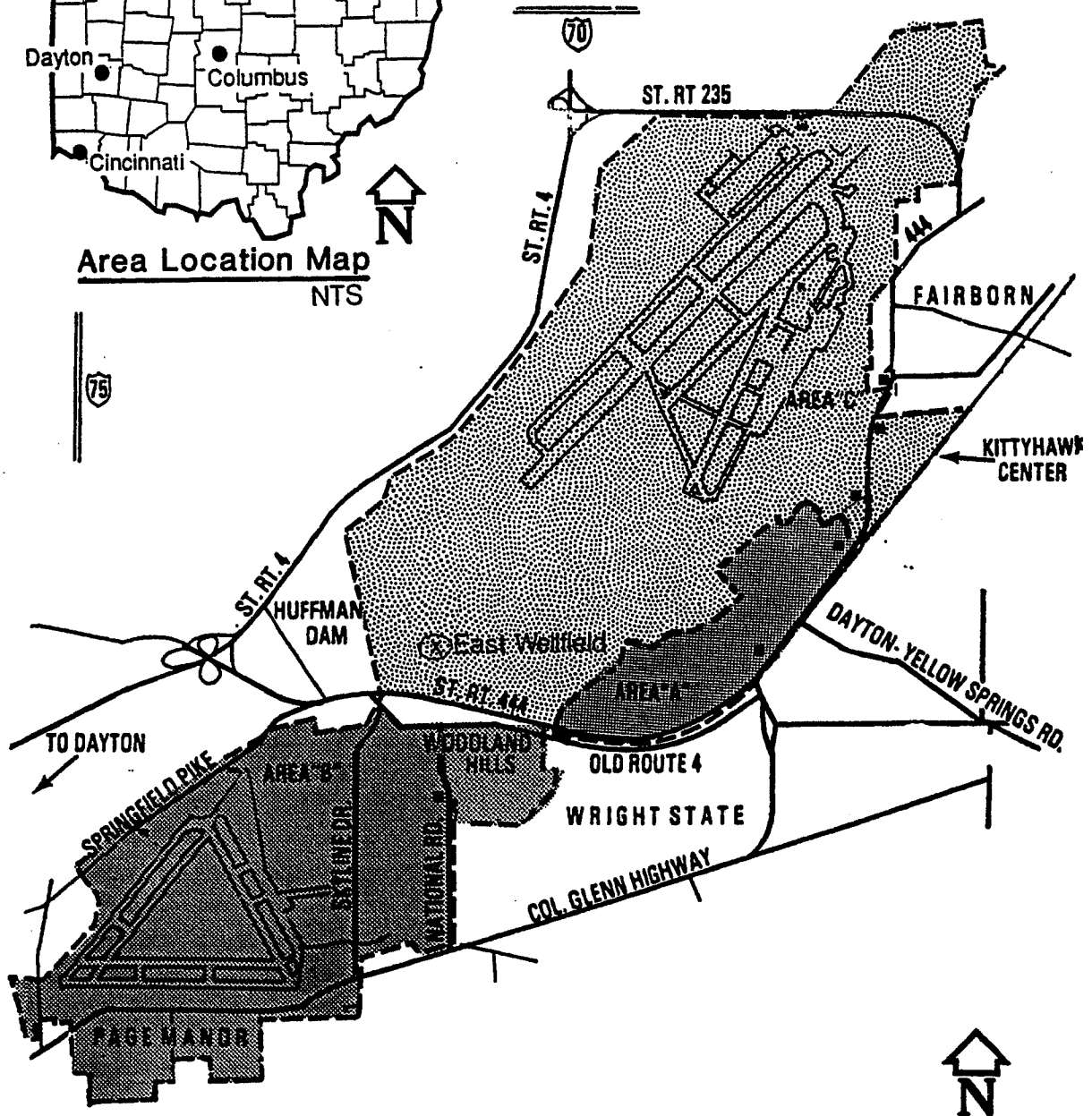

FIG. 2-2 WRIGHT-PATTERSON AIR FORCE BASE
NTS

Groundwater is the most important source of water in the area. Dayton, Fairborn, WPAFB, and other local communities all use groundwater for their drinking water supply. The Base is located atop a highly productive aquifer in the glacial deposits of the Mad River valley. The aquifer consists of sands and gravels that overlie a buried valley - bedrock system.

WPAFB is in the north temperate climate zone. July is the warmest month with a 76°F mean temperature, while January is the coldest month with a 28°F mean temperature. Extreme recorded temperatures are 102°F and -24°F. The average annual precipitation of 38 inches is fairly evenly distributed throughout the year. Mean snowfall averages 20 to 30 inches.¹

ORGANIZATIONS

Wright-Patterson AFB is the Air Force's largest base in terms of work force, and, at 8,500 acres, one of the largest in land area. It is the home of numerous organizations including:

- The Air Force Materiel Command which has worldwide responsibilities for all of the Air Force's supply, depot maintenance, and repair functions.
- The Aeronautical System's Center, the largest product division of the former Air Force Systems Command and the largest single organization at the Base, which conducts research and development for all new Air Force aircraft systems.
- The Wright Laboratories, the Air Force Museum, the Air Force Institute of Technology, the Foreign Technology Division, the USAF Medical Center, the 906th Tactical Fighter Group, and other Department of Defense activities.

The Base host, the 645 Air Base Wing (645 ABW), is responsible for all activities involved in operating the Base; including law enforcement, roads, utilities, supply and transportation, safety, building maintenance, accounting and finance, flying operations, trash collection, and waste disposal. The 645 ABW includes the Office of Environmental Management and the 645 Civil Engineering Squadron.

DEVELOPMENT

Wright-Patterson AFB developed as Areas A, B, and C (see Figure 2-2). Area B is to the south of State Highway (SR) 444 and the Conrail Railroad tracks; Areas A and C are to the north of the highway. Over the years, Areas A and C have gradually grown together, while SR 444 provides a distinct separation of Area B. Patterson Field, in Area C, has an active runway and flying mission. The runway at Wright Field, in Area B, is inactive except for occasional deliveries of aircraft for the Air Force Museum.

The Base has more than 2,500 acres of undeveloped land, but much of the acreage is restricted from certain types of development for various reasons such as; the Mad River flood plain, Indian burial mounds, steep slopes, and other cultural/natural features. The largest amount of restricted acreage is in the flood plain of the Mad River. The 100 year flood elevation of 818.6 or higher (see Appendix A) affects the Area C flightline and areas south and west of the flightline.

Page Manor is a Base family housing development located on the south side of Area B across Col. Glenn Highway. Woodland Hills is also a family housing development sited across National Road at the northeast corner of Area B. The Kittyhawk Center is separated from the east side of Areas A and C by SR 444. The Commissary, Main Base Exchange, Base Theater, and other recreational facilities are located in the Center.

The facility numbers of the buildings and related real property on the Base are preceded by a number that designates the Area in which they are located. For example, the USAF Medical Center, which is located in Area A, has the facility number 10830 with the 1 designating Area A. Similarly, a prefix 2 indicates Area B and a prefix 3 indicates Area C. This designation system is useful in determining the general location of a facility on this very large Base.

SUPPLY

The Base obtains its water from wells drilled into the aquifer underlying the facility. The wells are generally 50 to 80 feet deep and are highly productive, with most in the range of 500 gpm to 2,000 gpm. Table 4-1 in Section 4 lists the water supply wells used for each area of WPAFB. Area A well water is collected by a 12-inch pipe which carries the water from Wells 8 and 9 nearly 3,000 feet to air strippers adjacent to Building 10855. The Area C well water is collected by various pipes and pumped through air strippers which are in close proximity to Building 30172. Wells 1 and 2 are each in small wellhouses near Building 30172. Wells 3 and 7 are further away, about 700 feet and 1,700 feet to the southwest. There is no interconnection between the Area A and Area C wells.

Area B wells 1, 2, 4, and 5 are collected through a 20-inch pipe which terminates at reservoirs next to Building 20085. The East Wellfield, sited in Area C, is collected by a 24-inch pipe which travels beneath SR444 to the Area B reservoirs, a distance of over one mile.

The water quality from all wells is classified as very hard with a median hardness concentration of 378 mg/L reported.¹ High total dissolved solids (TDS) levels are also noted with most wells exceeding the 500 mg/L TDS secondary Maximum Contaminant Level (MCL) set by the Ohio Environmental Protection Agency (OEPA). The wells currently used for Areas A, B, and C are mostly within the 0.3 mg/L OEPA secondary MCLs for iron and the 0.05 mg/L OEPA secondary

MCL for manganese. However, the lettered wells in the East Wellfield, which are presently inactive, do have iron and manganese concentrations above the secondary MCL. These lettered wells will be usable after rehabilitation is completed in 1994. Secondary MCLs are, in general, non-enforceable standards that apply to aesthetic criteria related to the public's acceptance of drinking water. However, OEPA has advised the Base that iron and manganese will need to be addressed during the rehabilitation of the East Wellfield. Iron and manganese above their secondary MCLs will impart reddish-brown and black stains to laundry, plumbing, and anything else which comes in contact with the water.

Volatile organic chemical (VOC) contamination has been detected in almost all of the drinking water wells. The contamination likely originated from landfills, spill sites, leaky underground storage tanks, and poor housekeeping that occurred in the past history of the Base. The Base operational history is noted in Table 2-1, as supported by Figures 2-3 and 2-4, which have been extracted from the WPAFB Management Action Plan.² The VOC levels in the Base wells are relatively low and stable. Under these conditions, the VOC's are amenable to removal by standard water treatment processes.

Much work has been done recently to identify the location and magnitude of the underground contamination and to correct the identified problems. This work can be expected to continue well into the future as remediation projects are initiated, funded, and completed. Programs to prevent future contamination are especially important for the long term protection of the WPAFB drinking water supply. The Management Action Plan, completed in September 1993, provides detailed information on past industrial activities, the status of current environmental programs, and a installation-wide strategy for environmental compliance. Figures 2-5 and 2-6, also extracted from the Management Action Plan, indicate Operable Units (OUs) which designate areas undergoing or requiring remedial activities as grouped by geographical location on WPAFB. The relationship between the OU locations and the VOC contamination of the wells is evident at most well sites.

The Area C wells have the most variety of VOCs at the highest concentrations. Tetrachloroethylene and trichloroethylene are the primary contaminants with several other VOCs analyzed at lower concentrations. Area A wells are also contaminated with trichloroethylene at levels close to the MCL for drinking water. Trichloroethylene is the major VOC detected in Area B wells at levels above the MCL. The lettered wells in the East Wellfield have mostly undetectable VOC levels, except Wells A and F which have low levels of cis-1, 2-dichloroethylene and, in Well F, 1, 2-dichloroethane. Section 5, Qualitative Analysis of Supply Options, provides a detailed analysis of Base well water quality.

The OEPA is planning to implement a wellhead protection program to protect underground water sources from contamination. The water supplier will be required to enforce measures to eliminate contamination near their water supply wells. Refer

TABLE 2-1**History of WPAFB Operations
MAP (September 1993)
Wright-Patterson AFB, Ohio**

Period	Type of Operation	Potential Hazardous Substance Activity	Map Reference
1904-1916	Wright Brothers conducted aircraft experiments and flying lessons	Small quantity fuels	1
1917	Military aviation school	Fuels	2
1918	Fairfield Aviation Depot for warehousing and supply operations	Fuels, industrial shops for aircraft engine maintenance	3
1927	Wright Field constructed for design, construction, and testing of military aircraft and components	Fuels, industrial shops, research and development shops and laboratories	4
1940-45	Wright Field expanded from 30 to 300 buildings. Patterson Field added warehouses, paved runways, and headquarters complex (Area A).	Fuels, industrial shops, research and development shops and laboratories, construction debris	4 3 5
1951-Present	Combat units have included the 56th Fighter-Interceptor Squadron, the 58th Air Division, the 17th Bomb Wing, and the 906th Tactical Fighter Group.	Fuels, fire protection training areas.	4 5 6

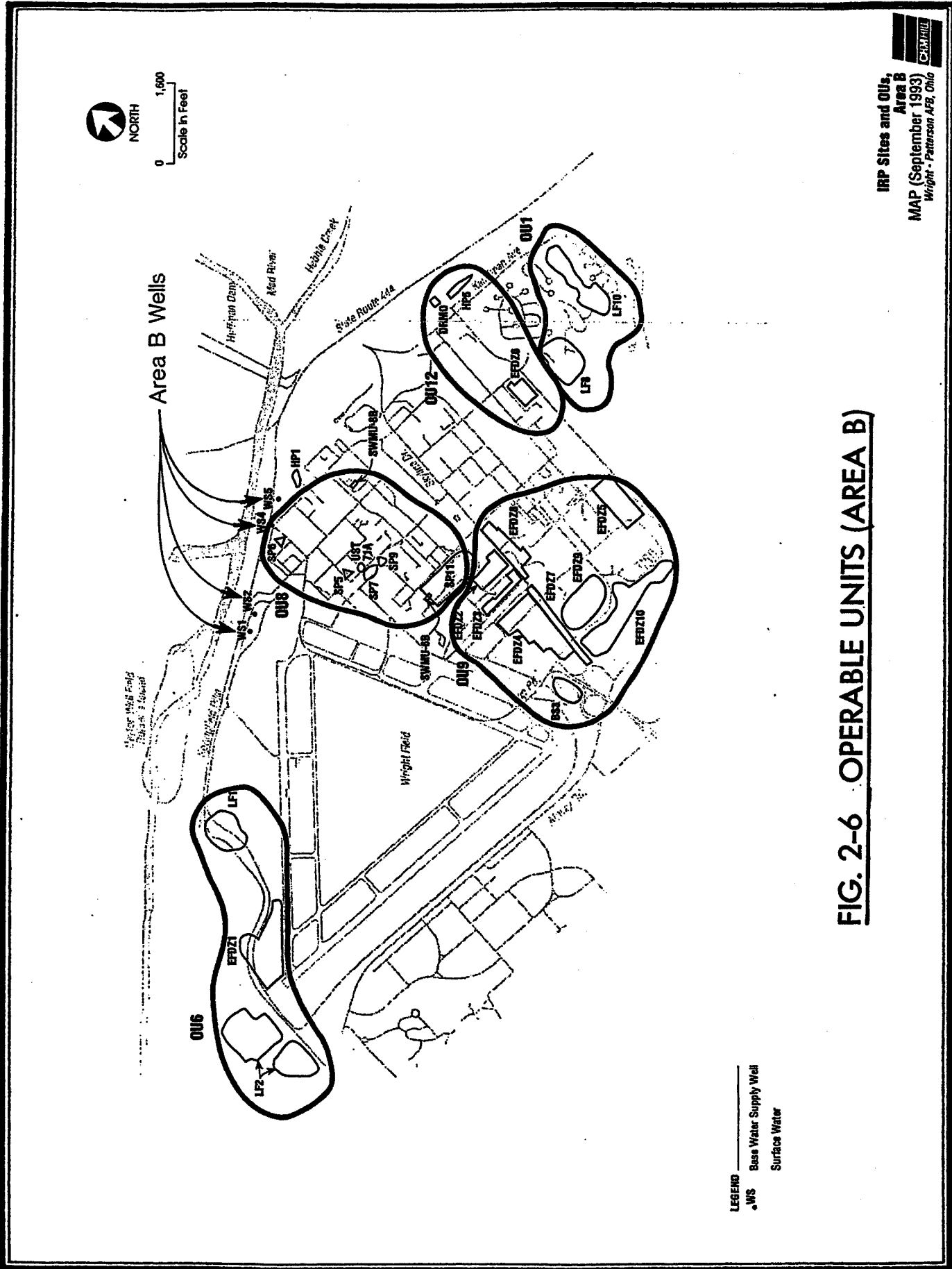

FIG. 2-6 OPERABLE UNITS (AREA B)

IRP Sites and OUs,
 Area B
 MAP (September 1993)
 Wright - Patterson AFB, Ohio



to Section 4, Appendices B and C, and the Management Action Plan for further information relating to wellhead protection. The USGS has created a computer model of the WPAFB aquifer to aid in developing a wellhead protection program.

In addition, the Base is upgrading all wells as necessary to maintain their status as a ground water supply not under the influence of surface water (see Appendix B). If the wells are classified as under the influence of surface water, the Base would have to construct a surface water treatment process, such as coagulation and filtration, and be subject to more stringent treatment regulations. OEPA will make its decision on this matter by June 1994. Appendices B and C discuss OEPA requirements and actions that the Base is undertaking to maintain groundwater not under the influence of surface water status.

The well upgrading program will also increase the reliability of the well supply by installing new pumps and repairing well components. At the present time Area B has only one reliable well (#5) and a backup well (#2) of questionable reliability.

TREATMENT

Each of the three Areas of the Base has a separate water treatment facility. The Area A, B, and C facilities all use the same treatment processes and are operated in the same manner. The treatment processes perform the following functions:

- VOC removal
- Scaling control
- Chlorination
- Fluoridation (for family housing areas)
- Softening (for family housing areas and Kittyhawk Center)

In water treatment practice, an aeration process brings water in contact with air to effect concentration changes in volatile substances in the water. At WPAFB, an aeration process known as air stripping is used to remove VOCs from the well water. Each Area treatment facility has two packed tower air stripping units designed specifically for VOC removal. Figures 2-7, 2-8, and 2-9 present schematic descriptions of each Area's water system. Packed tower aeration involves passing water down through a column of packing material, while pumping air concurrently up through the packing.

Prior to air stripping, polyphosphate is fed into the water for controlling scale build-up in the air stripper media and in valves, pumps, and piping downstream from the air strippers. Carbon dioxide gas is added after the air strippers as part of the scale control process. Chlorine is also added after air stripping to maintain a residual in the distribution system which will destroy pathogenic microorganisms. Operators attempt to maintain a chlorine residual of 1.5 mg/L, as higher residuals prompt complaints of chlorine taste and odor.

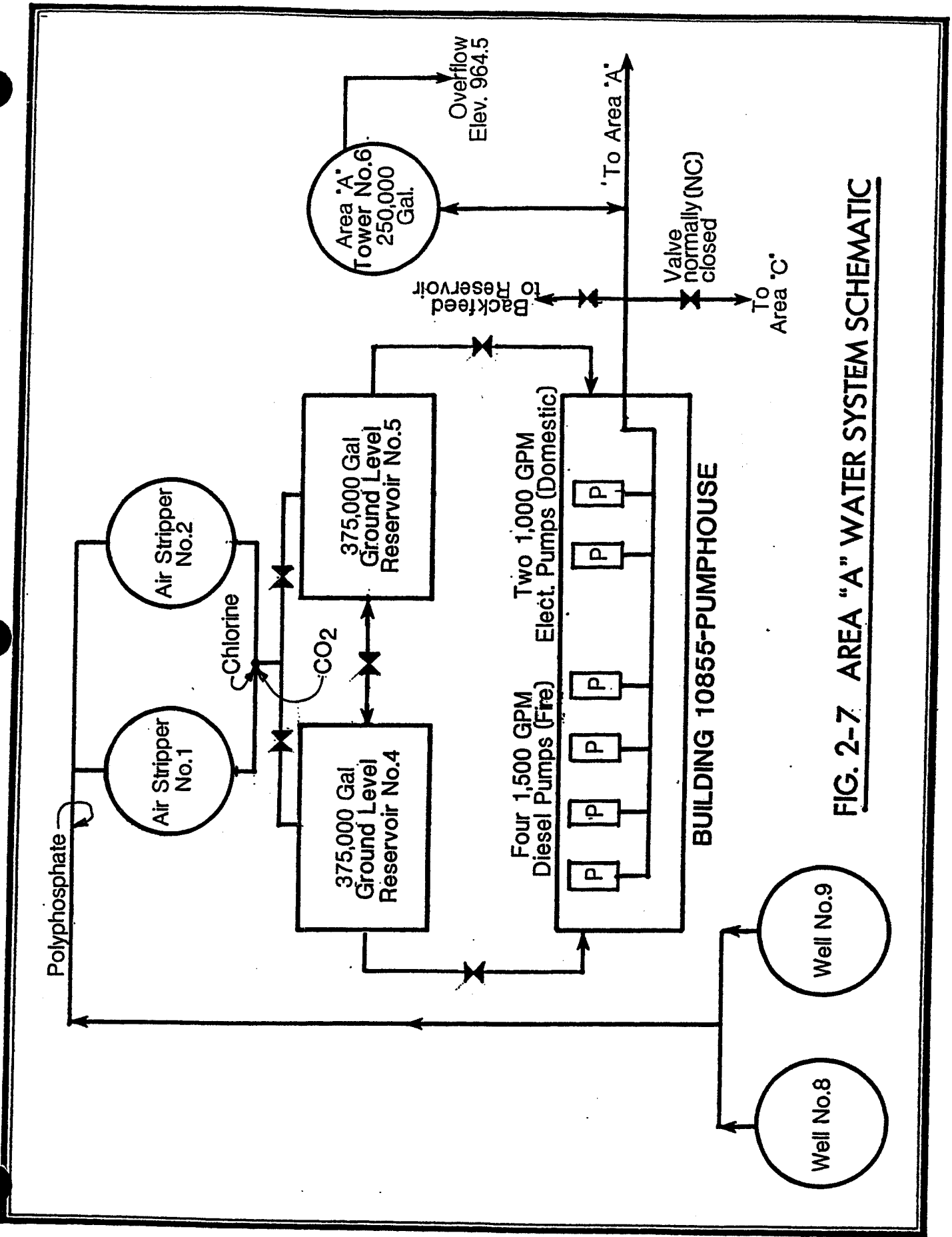

FIG. 2-7 AREA "A" WATER SYSTEM SCHEMATIC

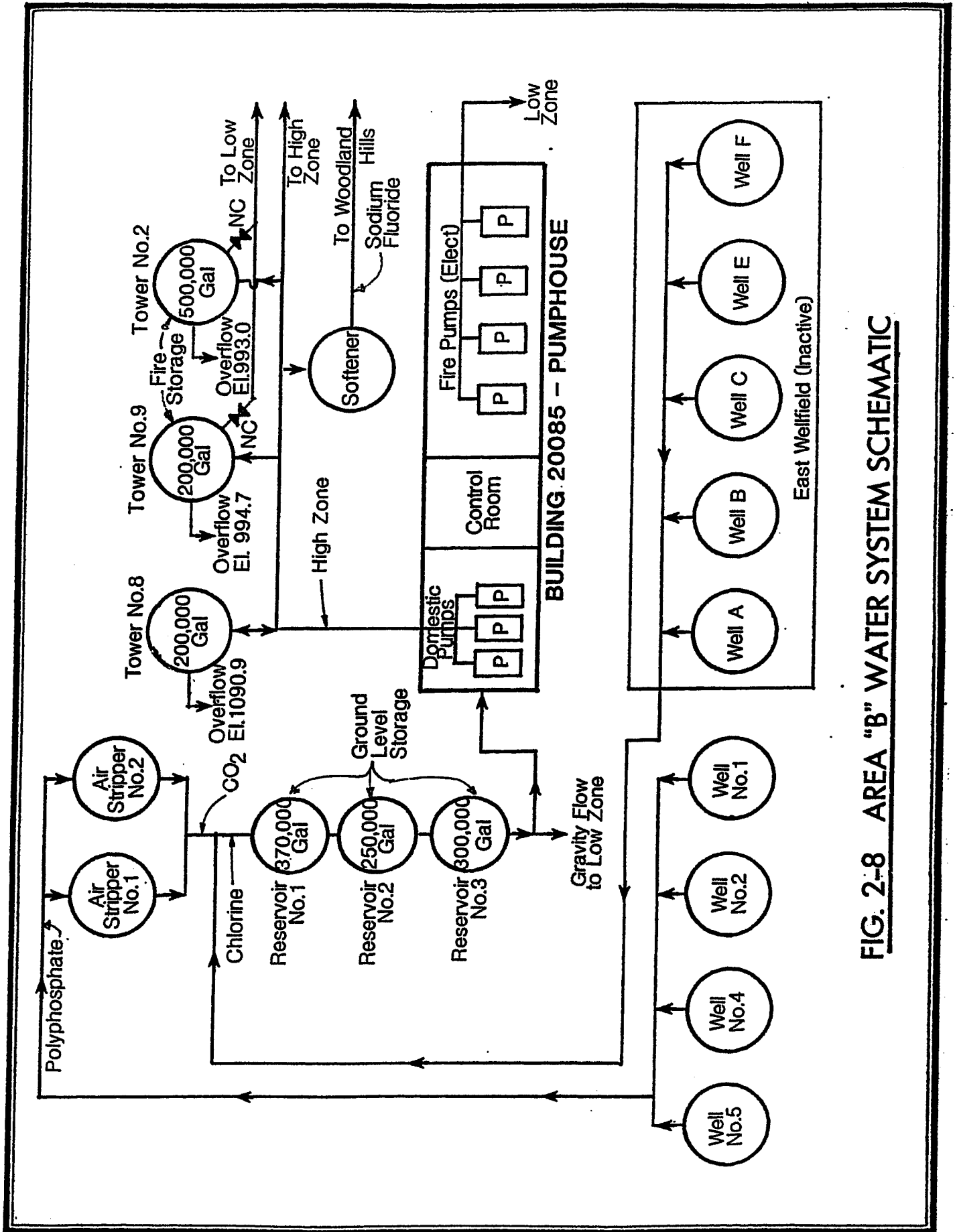

FIG. 2-8 AREA "B" WATER SYSTEM SCHEMATIC

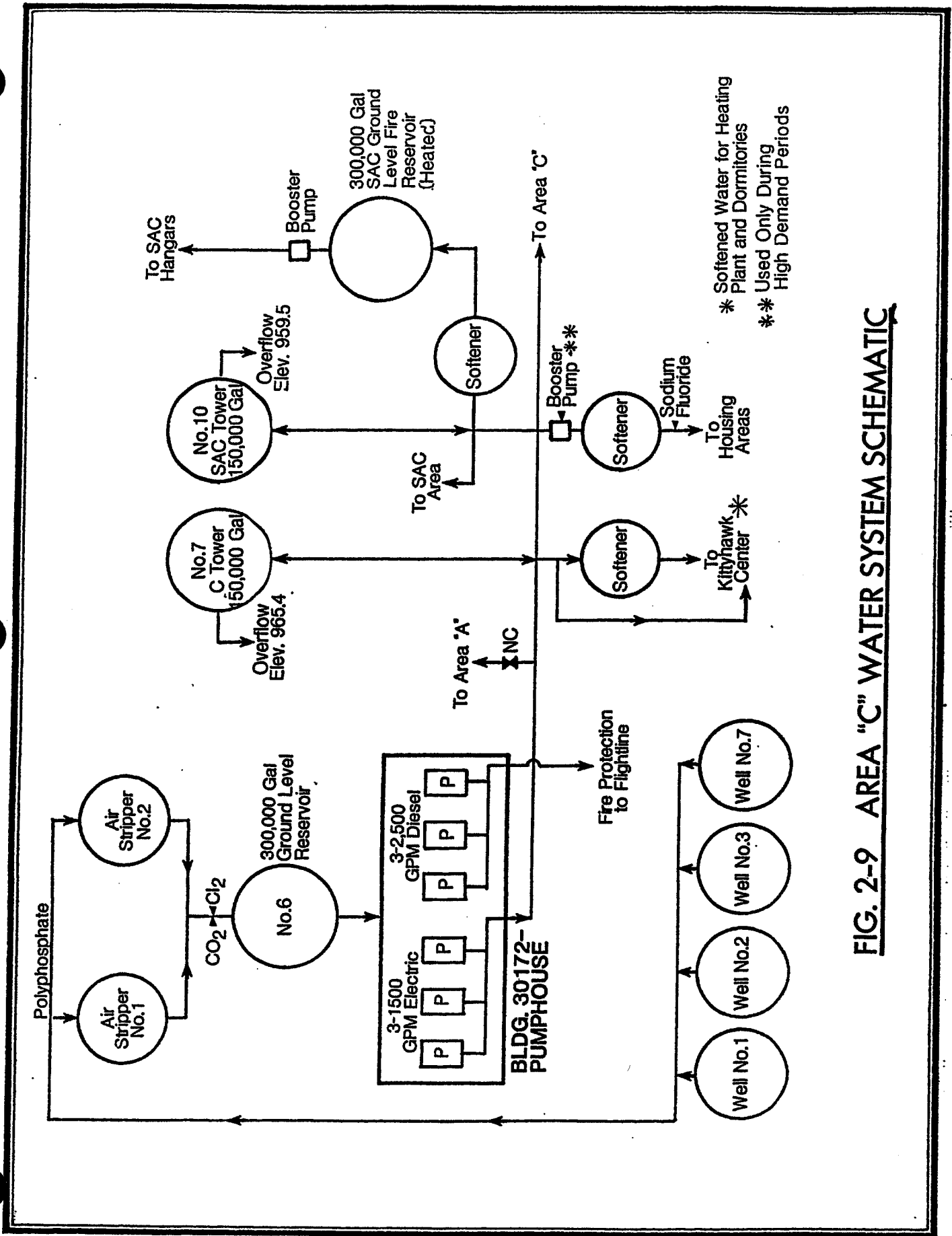

FIG. 2-9 AREA "C" WATER SYSTEM SCHEMATIC

Ion exchange units are used to soften the water for the family housing areas and the Kitty Hawk Center. The units for Woodland Hills and the Kitty Hawk Center are less than five years old; a new unit will soon be on line for Area A family housing. The softeners are operated to reduce the hardness to 80 mg/L, except the Kitty Hawk Center softener which removes all hardness to satisfy the needs of the central heating plant. Waste brine, produced by regeneration of the ion exchange media, is discharged to the sanitary sewer and conveyed to the City of Dayton for treatment.

The treatment processes allow each Area's water treatment facility to produce finished water that meets the current OEPA and USEPA primary standards set by the Safe Drinking Water Act. However, the nonenforceable secondary standard for TDS may not be attainable in all Areas with current treatment processes. Only one recent set of test data (February 1993)³ is available for finished water TDS since polyphosphate addition commenced. Area A exceeded the 500 mg/L TDS secondary standard, whereas Areas B and C did not.

Scaling had been a serious problem in all three Area water systems prior to feeding polyphosphate and carbon dioxide to the water as a means of control. The scaling had caused excessive build-up in valves and on the air stripper media which seriously affected operational capabilities, necessitated excessive maintenance, and caused premature valve replacement. Since scale control was initiated two years ago, there seems to be no serious problem of scale build-up in valves and on the air stripper media.

Area B experienced numerous problems with "brown" water in past years. The East Wellfield, with iron and manganese concentrations exceeding the secondary MCLs, provided about one-half of the Area B supply prior to 1985. From November 1985 to June 1989, the East Wellfield supplied most or all of the wellwater. Wells 1, 2, 4, and 5 have supplied Area B since June 1989, when the air strippers went on line, and iron and manganese levels have easily met the MCLs since that time.

However, iron in the Area B distribution system, deposited from the many years of operating the East Wellfield, continued to cause "brown" water complaints. The Base initiated pipeline replacement projects which resulted in 18,000 feet of old Area B piping being replaced. In addition, an intensive flushing program commenced to remove the iron deposits from the distribution piping. The pipeline replacement and flushing program, in conjunction with using low iron supply wells and adding polyphosphates for iron sequestering, has significantly improved the water quality in Area B.

DISTRIBUTION

Each Area of the Base has its own separate water distribution system as reflects the development pattern of the facility. There are interconnections between

Areas A and C water distribution piping, but Area B is completely separate from the others. In addition, there are three 6-inch interconnections between the City of Fairborn and Area C as further discussed in Section 4.

It is probable that each Area's distribution system was constructed to match the population growth of the Base. Therefore, most of the water pipelines were likely constructed in the World War II era when the Base experienced enormous growth. Employment increased from 3,700 to almost 50,000 during this period, with accompanying construction of new buildings, hangars, barracks, and offices. Much of the Base water distribution system, then, is in the range of 50 years old.

Cast iron is the dominant piping material in the old portions of the system. Newer lines, such as the 18,000 feet of replacement piping recently installed in Area B, are constructed of ductile iron or PVC. The family housing areas of Pine Estates and Green Acres have a large amount of asbestos cement pipe. Small amounts of other pipe materials are present in smaller diameters.

The majority of the distribution piping is providing dependable service with no record of frequent line breaks or other extraordinary maintenance problems. An exception to this is the 14-inch line between Well E and the West Ramp (formerly SAC) area which is broken and out of service. This line was intended to be used only for emergencies and the water received no treatment.

The water system piping has been flushed, especially in Area B, but no line inspection or cleaning has been performed. A project to do a leak and pipe condition survey (Project #891010) is awaiting bid advertisement. Another project awaiting advertisement will replace 100 distribution gate valves (Project #890160). Various projects to improve the reliability of the distribution system, storage, and treatment facilities are in the early stages of design (see Appendix D).

STORAGE

WPAFB has a mixture of ground level and elevated water storage in each Area of the installation. Table 2-2 lists the types of storage in each Area along with the volumes and other pertinent data. Additional data on storage facilities, including elevations and diameters, is provided in Appendix E.

As previously presented in Figures 2-7, 2-8, and 2-9, the treated water from the air strippers flows by gravity to ground level storage reservoirs prior to its distribution. The amount of ground level domestic storage varies from 300,000 gallons in Area C to 920,000 gallons in Area B. The potable water is pumped from the ground level storage reservoirs to the elevated tanks or towers on the Base. Area B has the largest volume of elevated storage with 900,000 gallons available for fire and domestic usage.

**TABLE 2-2
WPAFB WATER STORAGE**

DESIGNATION	AREA LOCATION	FACILITY #	TYPE	VOLUME	USE
RESERVOIR #4	A	10855A	GROUND LEVEL	375,000	DOMESTIC
RESERVOIR #5	A	10855B	GROUND LEVEL	375,000	DOMESTIC
TOWER #6	A	10029	ELEVATED TANK	250,000	DOMESTIC
RESERVOIR #1	B	20085**	GROUND LEVEL	370,000	DOMESTIC
RESERVOIR #2	B	20085**	GROUND LEVEL	250,000	DOMESTIC
RESERVOIR #3	B	20085**	GROUND LEVEL	300,000	DOMESTIC
TOWER #8	B	20348	ELEVATED TANK	200,000	DOMESTIC
TOWER #2	B	20460	ELEVATED TANK	500,000	FIRE
TOWER #9	B	20222	ELEVATED TANK	200,000	FIRE
RESERVOIR #6	C	30172A	GROUND LEVEL	300,000	DOMESTIC
TOWER #7	C	30032A	ELEVATED TANK	150,000	DOMESTIC
TOWER #10 (SAC)	C	34045	ELEVATED TANK	150,000	DOMESTIC
WEST RAMP (SAC) AREA	C	34024	GROUND LEVEL	300,000	FIRE

* VOLUME IN GALLONS

** FACILITY # OF ADJACENT PUMPHOUSE

TOTAL AREA B STORAGE (FIRE & DOMESTIC) = 1.82 MG
 TOTAL AREAS A&C STORAGE (FIRE & DOMESTIC) = 1.90 MG
 TOTAL WPAFB STORAGE = 3.72 MG

The elevated storage tanks are constructed of steel. Most of the ground level reservoirs are constructed of concrete with concrete roofs. An exception is Reservoir #6 in Area C. This reservoir previously had a concrete roof which collapsed and was replaced with an aluminum dome. Another exception is the West Ramp area where the ground level fire storage reservoir is constructed of steel. The water in this reservoir is not circulated. Therefore the reservoir is heated to prevent winter freeze-up.

Two projects listed in Appendix D pertain to storage improvements. Project 900143 will replace Tower #7 with a new elevated water tank. Project 920066/920204 will replace the Area A reservoirs' roofs and connect ground level reservoir drains indirectly to the sanitary system.

PUMPHOUSES

Each Area has a pumphouse to transfer treated water from the ground level reservoirs to the distribution system and elevated storage tanks. The pumphouses all have electrically powered pumps for normal daily usage and diesel or electric powered pumps for emergency use in the event of fire or other emergencies.

Facility #10855 is the pumphouse for Area A. This two level brick building has a water laboratory in its upper level and the pumps in the lower level. The lower level is below grade and has flooded on at least two occasions. Two 1000 gpm pumps with 75 horsepower electric motors are used for normal daily operations. Four 1,000 gpm diesel powered pumps are available for emergency operations. The diesel pumps are valved to pump into the domestic water system. The diesel pump discharge header and valves are in poor condition and should be replaced. Valves outside of the pump house allow Area A to feed Area C systems or vice versa. Normal system operation is for Area A and Area C water systems to operate independently, except for a small, 4-inch connection along Skeel Avenue.

The pumphouse for Area B is noted as Facility #20085A. This ground level structure is sited on a hill at an elevation of just over 925 which allows gravity flow to most of the buildings below Skyline Drive. The high zone is supplied by three domestic pumps in the north end of the pumphouse. Two of these 2,000 gpm pumps are electrically powered, while a third pump is diesel powered as a standby. There are four fire pumps at the south end of the pumphouse. These pumps supply the low zone with fire flow when operating. A control room is located between the domestic pump room and the fire pump room. In this room, operators monitor a control panel indicating well operation, tank levels, and line pressure.

A large portable generator is located outside of the building for emergency usage. This generator powers the 75 horsepower fire pumps. These pumps were formerly driven by gasoline engines which have become obsolete and nonoperational.

A small generator is located within the fire pump room. This generator powers lights and controls in the pumphouse.

Facility #30172, the pumphouse for Area C, consists of a ground level brick building with three domestic and three fire pumps. The 100 horsepower electric motor driven domestic pumps are rated at 1,500 gpm each. The diesel driven fire pumps each have a 2,500 gpm capacity. The fire pumps feed a separate fire protection pipeline that protects hangars and other flightline activities. The domestic and fire protection pipelines are not interconnected.

On the west side (West Ramp) of the runway is the former SAC area, now occupied by the 4950th Test Wing which is scheduled to relocate to Vandenburg AFB. The 907th Airlift Group of the Air Force Reserves will be moving its operations to this location from nearby Rickenbacker ANG Base in Columbus. The West Ramp area is supplied by only one pipeline installed around the north end of the runway. The pipe is 10-inches in diameter on the east side and increases to 12-inches as it passes Taxiway 11. The pipe is laid beneath the north overrun and its repair, if ever required, may necessitate the interruption of airfield operations.

The 14-inch fire protection pipeline from Well E to the West Ramp area is not useable. Fire protection is available from the elevated tank and the 300,000 gallon ground level reservoir which is dedicated for fire usage only in the hangars. A 4,000 gpm pump provides fire flow from the ground level reservoir for the protection of hangars and aircraft. The pump can be driven by either a 350 horsepower electric motor or a diesel engine.

Further information on pumps and motors may be found in Appendices entitled "Pump Database" and "Pump Curves" to the referenced Woolpert Consultants' reports.^{4,5}

SECTION 3

CURRENT AND PROJECTED DEMANDS

EXISTING CONDITIONS

Areas A and C - The water systems for areas A and C are usually operated as two independent systems. A 4-inch main connects the two and is normally in the open position. However, a small pipe like this provides minimal system interconnection. Other larger interconnecting water mains are normally kept closed off. Each system has specific wells, air strippers, water softeners, elevated tanks, reservoirs, pump stations, and facility demands assigned to it. Detailed information on each system is included in Section 2 of this study. Figures 2-7, 2-8, and 2-9 show in schematic form the water system for each Area.

Several ground level reservoirs and three elevated towers exist in the Areas A and C water systems. Each tower serves a specific Area. Tower 6 serves Area A, Tower 7 serves Area C, and Tower 10 serves the West Ramp (SAC) area. The West Ramp area is analyzed as being in the Area C water system. All of the towers are connected to the domestic water system.

The daily usage of water can be estimated from flow meters installed on wells and the air strippers. Propeller type flow meters at wellheads are generally operable and totalize each well's usage. Each air stripper has a flow meter on its influent line that provides totalized flow data. The flow information from the wells and air strippers are compared to determine an estimate of daily usage. In addition, some of the reservoirs and towers have level indicators with recording on graphs that provide a pattern of diurnal water demand in each Area.

The water system daily demands for each of the facilities in Areas A and C were estimated based on information received from the Base. The estimated daily water demand is 520,000 gpd for Area A and 1,280,000 gpd for Area C.

The Woolpert Consultants' report⁵ distributed this flow to each facility located in these Areas. Exhibits 1 and 2 of that report should be reviewed if additional information is required. These exhibits present a listing of each facility within the Area, its building area, estimated water demands, and population served. The population served was estimated to be 17,700 personnel. This estimate conflicts with a population of 19,287 reported as part of the OEPA Survey (Appendix B).

Land use is an important consideration in any evaluation of water usage. WPAFB is a non-closing installation, therefore the existing land use for the Base and surrounding vicinity as presented in the Base Comprehensive Plan⁶ is of great con-

cern. Each Area of the Base contains a diversity of land uses. However, Area A is primarily devoted to administrative functions, while Area C includes airfield operations, maintenance, and civil engineering functions. Airfield functions constitute 24 percent of all on-Base land uses. Figure 3-1 is included to indicate the current land use for Areas A and C. This figure was developed by CH₂M Hill as part of the Management Action Plan² prepared for the Office of Environmental Management.

Area B - Area B has a water system completely separate from Areas A and C. The water supplied in Area B is currently provided by four wells. The wells pump through a raw water main to two air strippers located near Facility #20085A with polyphosphate being added prior to stripping. Water flows from the air strippers by gravity, is treated with carbon dioxide, chlorinated, and discharged into Reservoir 1. The treated water then flows over a weir by gravity to Reservoirs 2 and 3 and to booster and fire pump suction locations located in Facility #20085A. Wells A, B, C, E, and F in the East Wellfield are connected to the Area B distribution system, but are not presently in service.

The Area B water system consists of three pressure zones. The low pressure zone is located in the western, lower elevation portion of Area B and is supplied by gravity flow from Reservoirs 1, 2, and 3. The high pressure zone is located in the eastern, higher elevation portion of Area B and is served by three pumps in Facility #20085A. These pumps are manually operated based on the level in Tower 8. The regulated pressure zone receives water from the high pressure zone and is controlled by a pressure regulating valve located near Facility #20053. This valve is set to reduce the pressure to 60 psi.

Four pumps in Facility #20085A are used to supply water during a fire. The discharge from these pumps is valved to allow the water to flow into the low pressure zone. Towers 2 and 9 are used for fire water storage. These towers are filled and then valved off from the system. At each of these towers, valving exists to allow either or both of the towers to be connected to the low pressure zone.

There are no flowmeters in the Area B water system, except for the propeller meters at the wellheads. The water system daily demands for each facility were estimated based on information received from the Base. The total estimated water demand for Area B was given as 1,620,000 gpd.

The Woolpert Consultants' report⁴ distributed this flow to each facility located in Area B. Exhibit 1 of that report should be reviewed if additional information is required. This exhibit presents a detailed listing of each facility, its building area, estimated water demands, and population served. The population was estimated at 36,100, which included 16,000 visitors to the Air Force Museum. For comparison, a population of 17,704 was reported as part of the OEPA Survey (Appendix B).

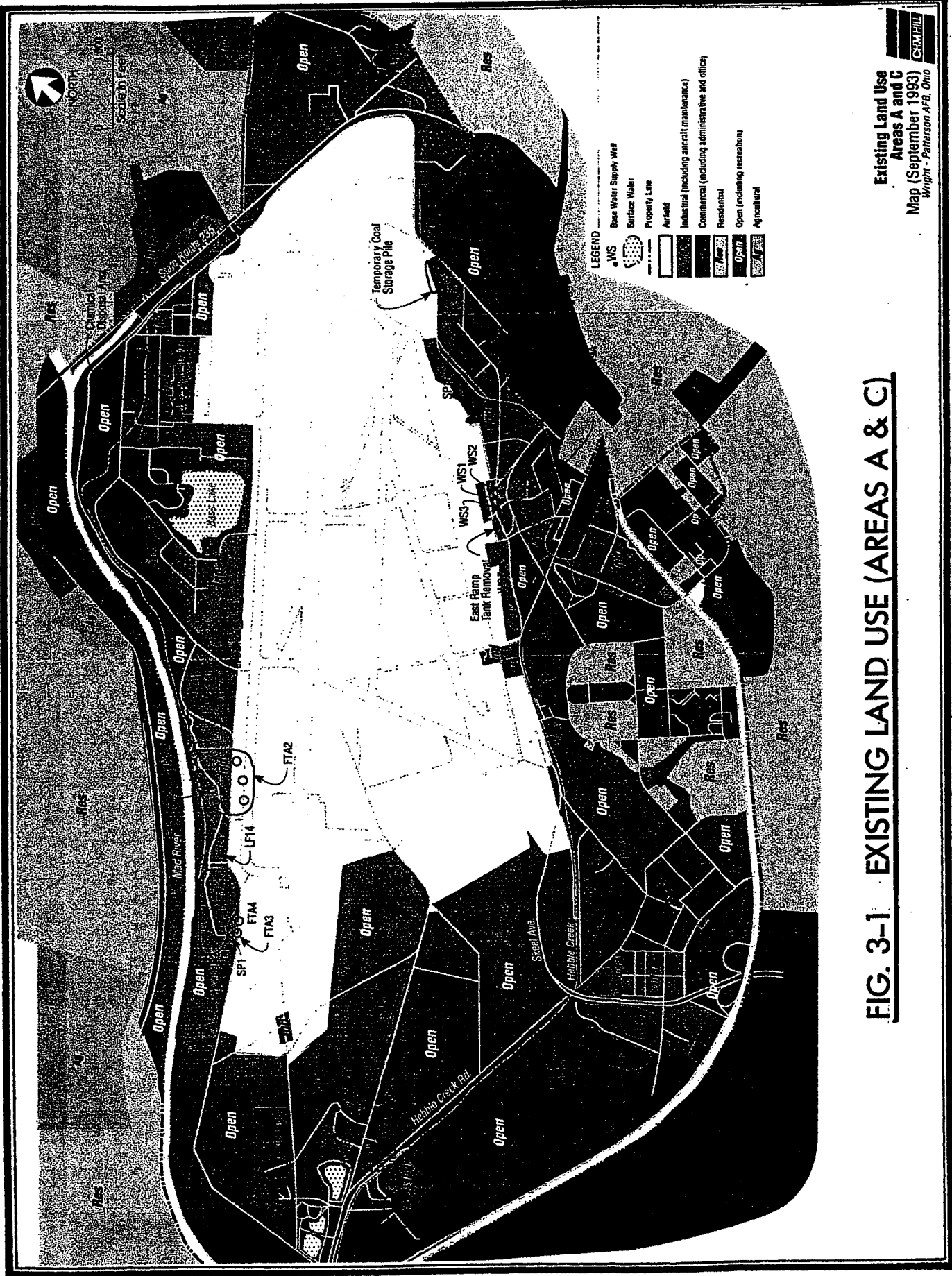

- LEGEND**
- WS Base Water Supply Well
 - Surface Water
 - Property Line
 - Airfield
 - Industrial (including aircraft maintenance)
 - Commercial (including administrative and office)
 - Residential
 - Open (including recreation)
 - Agricultural

FIG. 3-1 EXISTING LAND USE (AREAS A & C)

**Existing Land Use
Areas A and C**
Map (September 1993)
Wright - Patterson AFB, Ohio



Area B is primarily research and development functions. Residential development, the Air Force Institute of Technology, and the Air Force Museum are also served. Figure 3-2 is included to indicate current land use within the Area. This figure was obtained from the Management Action Plan.²

PROJECTED DEMANDS

The Base provided an estimate of the future daily water demands in the Woolpert Consultants' reports^{4,5} based on an approximate square footage for projected facility additions and the fiscal year that the additions would be connected to the water system. Demands shown for these facilities were estimated by using factors for similar facilities in each Area which have approximately the same square footage. Modifications were made to these numbers following meetings with Base planning personnel.

The results are presented in Tables 3-1 and 3-2. Table 3-1 indicates that Areas A and C will have an additional net demand of 21,900 gpd. Table 3-2 indicates an additional net demand for Area B of 194,200 gpd. The additional net demand for Area B may be too high since many of the new facilities will replace existing structures which will be demolished or inactivated. However, for the purposes of this plan, the demand indicated in Table 3-2 will be used. The total projected water demands are therefore 1.822 MGD for Areas A and C, 1.814 MGD for Area B, and 3.636 MGD for the entire WPAFB service area.

The projection of water demand for a military installation is difficult since it is subject to national and international considerations which are not predictable. WPAFB has already experienced an abrupt population growth during World War II and a considerable post-war reduction in forces. The large variety of organizations presently located at the Base and the recognized importance of WPAFB as an Air Force installation makes it unlikely that any major reduction in forces will occur in the future. In fact, as base closures occur elsewhere, it is just as likely that WPAFB may absorb an orphaned unit and thus increase the Base water demand. In addition, if a significant military conflict occurs, the Air Force bases that are currently active will surely realize an increase in population.

It would therefore be prudent to follow a conservative course when attempting to project future demands. The importance of WPAFB as a major Air Force installation indicates a low probability of any large reduction in water demand and a much more likely scenario of increased future water consumption.



0 1,600
Scale in Feet

AREAS A and C

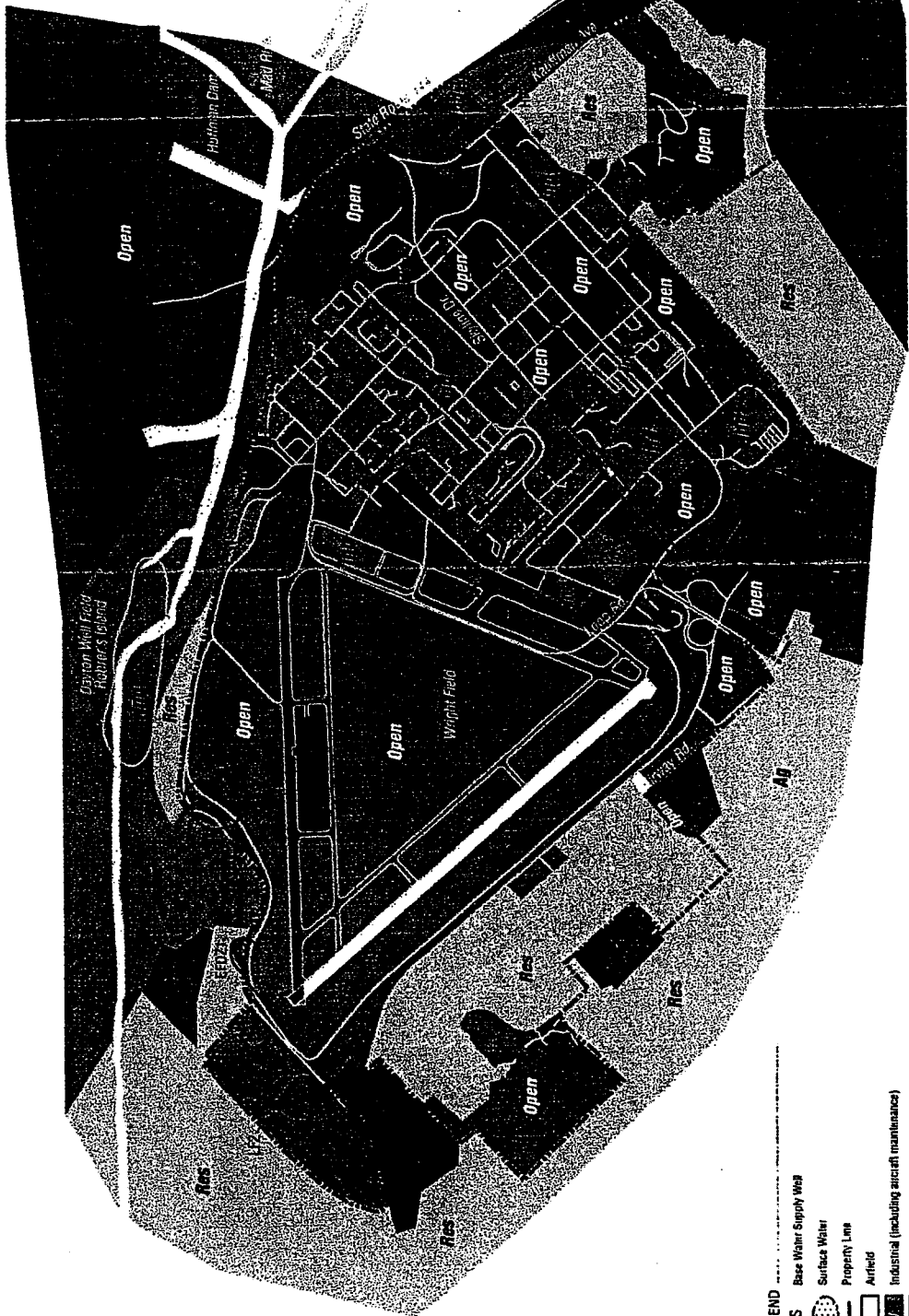

- LEGEND**
- WS Base Water Supply Well
 - Surface Water
 - Property Line
 - Airfield
 - Industrial (including aircraft maintenance)
 - Commercial (including administrative and office)
 - Residential
 - Open (including recreation)
 - Agricultural

FIG. 3-2 EXISTING LAND USE (AREA B)

Existing Land Use
Area B
MAP (September 1993)
Wright - Patterson AFB, Ohio



TABLE 3-1

**WATER SYSTEM FUTURE DEMAND
AREAS A AND C**

FACILITY NUMBER	TOTAL SQ. FT.	EST. WATER DEMANDS	REMARKS	ADDITION/NEW/COMMENTS
FY91	12,000	7,400	CHILD CENTER	New, near Fac. 31XXX
FY92	35,000	3,000	FOREIGN MAT. LAB.	New, near Fac. 34XXX
FY93	54,000	0	HAZARDOUS STORAGE	New, near Fac. 30208
FY93	35,300	6,000	AIRCRAFT MAINTENANCE	New, West Ramp area
FY95	26,000	5,200	ADMINISTRATION	New, at Fac. 30025
FY96	21,600	300	WAREHOUSE	New, near Fac. 10830

TOTALS

21,900 gpd

TABLE 3-2
WATER SYSTEM FUTURE DEMAND
AREA B

FACILITY NUMBER	TOTAL SQ. FT.	EST. WATER DEMANDS	REMARKS	ADDITION/NEW/COMMENTS
FY91	15,800	2,000	LAB	Addition to Fac. 20248
FY91	54,000	21,000	EDUCATION	New, near Fac. 20640 area
FY92	107,000	16,000	ADMINISTRATION	New, ASD Tomorrow area
FY92	53,000	7,000	ADMIN./LAB.	Addition to Fac. 20620
FY93	9,600	2,200	FIRE STATION	New, near Fac. 20464
FY93	82,500	32,000	EDUCATION	New, near Fac. 20640 area
FY93	5,400	500	LAB	Addition to Fac. 20071B
FY93	37,000	5,000	ADMIN./LAB	New, near Fac. 20620
FY93	138,000	20,500	ADMINISTRATION	New, ASD Tomorrow area
FY94	70,800	15,000	ADMIN./LAB	Addition to fac. 20065
FY94	44,700	3,500	SHOP	Addition to Fac. 20031
FY94	67,300	20,000	MED. LAB	Addition to Fac. 20079
FY95	22,400	4,500	OCCUP. HEALTH	New, near 5th & Q Sts.
FY95	60,000	8,000	ADMIN./LAB	Addition to Fac. 20620
FY95	31,140	4,000	ADMIN./LAB	Addition to Fac. 20024
FY95	60,000	8,000	ADMIN./LAB	Addition to Fac. 20620
FY96	45,000	6,000	ADMIN./LAB	Addition to Fac. 20620
FY96	81,000	12,000	ADMINISTRATION	Addition to Fac. 20676
FY97	47,100	7,000	ADMINISTRATION	Addition to Fac. 20485

TOTALS

194,200 gpd

SECTION 4

QUANTITATIVE ANALYSIS OF SUPPLY OPTIONS

GROUNDWATER

Groundwater is the source of drinking water for the WPAFB area. The majority of the Base is sited on top of a highly productive aquifer consisting of unconsolidated glacial sands and gravels filling a buried bedrock valley system.

Interbedded in the glacial sand and gravel outwash are discontinuous lenses of relatively impermeable clay till. On the Base, two to seven feet of dense, unsorted fill often separates the outwash from overlying alluvial soil deposits. In some places a till layer or layers may occur within the outwash and divide it into local hydraulic zones. This glacial drift aquifer of the Mad River Valley is typical of valley fill aquifers found in the northeastern United States. The bedrock underlying the Base consists of gently dipping sedimentary shales interspersed with thin beds of limestone. The bedrock is more than 200 feet deep beneath portions of Areas A and C and close to the surface near SR 444, the higher elevations of Area B, and at some locations along the Mad River (see Figures 4-1, 4-2, and 4-3 from USGS).

The directions of groundwater flow are provided in Figures 4-4 and 4-5 (USGS). In general, the groundwater flows from the uplands towards the major rivers of the region, including the Mad River. At times, the groundwater surfaces as a source of perennial flow in the Mad River or at former gravel pits such as Gravel Lake or Twin Lakes on the Base. Groundwater from Areas A and C converges near Huffman Dam as the aquifer narrows at this location. Below the dam, the flow direction turns downward to recharge the Dayton Wellfield.

Recharge of the water table is by direct percolation through soils and by recharge from surface streams such as Hebble Creek and Trout Run. The Base is a major aquifer recharge area in much of Areas A and C and almost all of Area B. Dayton has constructed artificial lagoons just north of Area B downstream from Huffman Dam. These lagoons enhance recharge of the large Dayton Wellfield sited along the Mad River on Roher's Island (see Figure 4-6).

In 1993, the USGS completed an extensive study of groundwater in the WPAFB area. Forty-five wells were tested to determine hydraulic characteristics of the groundwater. According to this report, production wells in the aquifer typically yield from 500 to 1500 gpm. In 1987, about 50 MGD was pumped from the valley deposits by the area's water suppliers. Most of this was used by the City of Dayton.

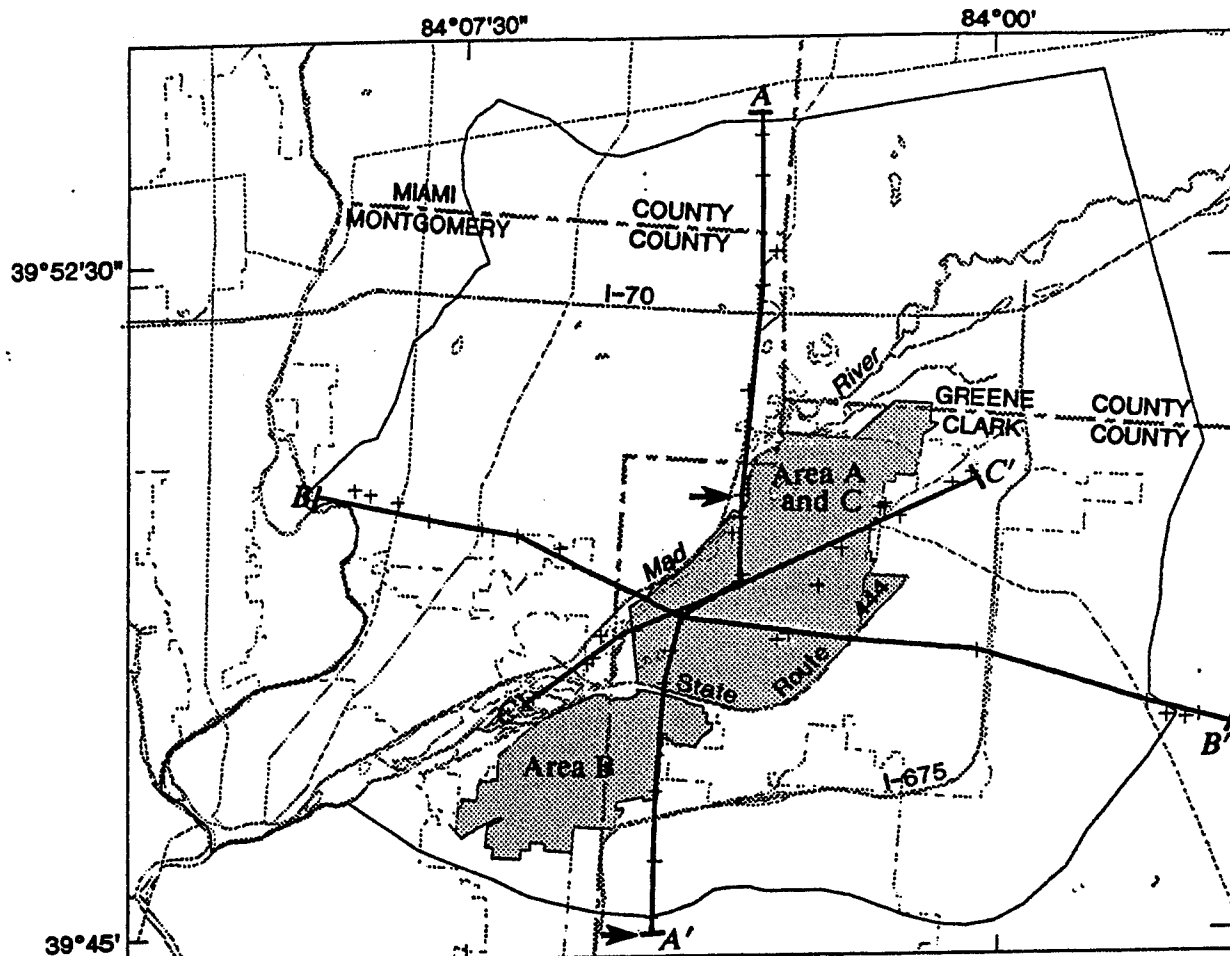

Base map digitized from U.S. Geological Survey
 Bellbrook, 1965, photorevised 1987; Dayton North,
 1965, photorevised 1981; Dayton South, 1966,
 photorevised 1981; Donnelville, 1965,
 photorevised 1973, photoinspected 1983;
 Fairborn, 1965, photorevised 1986; New Carlisle,
 1955, photorevised 1968 and 1973,
 photoinspected 1984; Tipp City, 1965,
 photorevised 1982; Xenia, 1965, photorevised
 1987; Yellow Springs, 1966, photorevised 1975.
 Polyconic projection

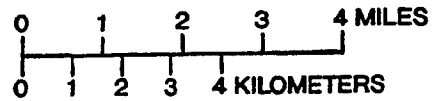

➔ Indicates portion of SECTION A-A'
 shown in Figure 4-2



EXPLANATION





-  WRIGHT-PATTERSON AIR FORCE BASE
- A—A' LINE OF SECTION
- + WELLS USED FOR GEOLOGIC SECTIONS

FIG. 4-1 LOCATION OF GEOLOGIC SECTION

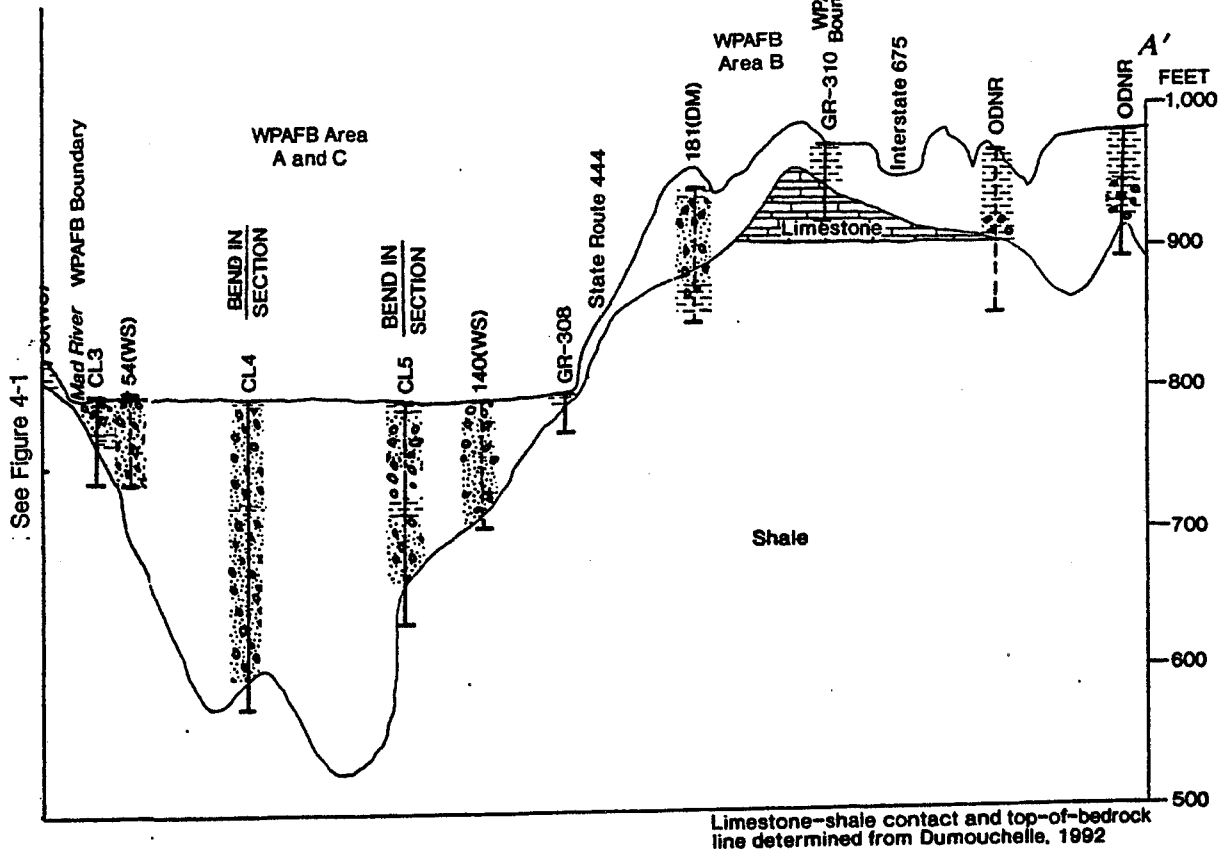

EXPLANATION

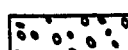
-  CLAY AND (OR) SILT
-  SAND
-  GRAVEL

-  WELL ON GEOLOGIC-SECTION LINE
-  WELL PROJECTED TO GEOLOGIC-SECTION LINE--All within 1,000 feet of section line

- WELL IDENTIFICATION**
- 140(WS) Log number in Waiton and Scudder (1960)
 - CL5 Well-cluster number, wells drilled by U.S. Geological Survey. Location in figure 2 (Dumouchelle and deRoche, 1991)
 - ODNR Well log on file with the Ohio Department of Natural Resources, Division of Water
 - GR-308 Well drilled by U.S. Geological Survey. Location shown in figure 2 (Dumouchelle and deRoche, 1991)
 - 181(DM) Monitoring well number, well installed by Dames & Moore, Inc. (1986a)

FIG. 4-2 GEOLOGIC SECTION A-A'

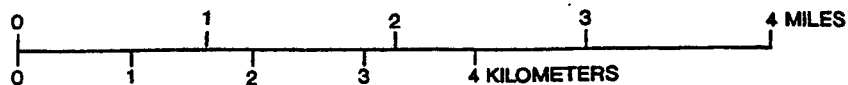

VERTICAL SCALE GREATLY EXAGGERATED
DATUM IS SEA LEVEL

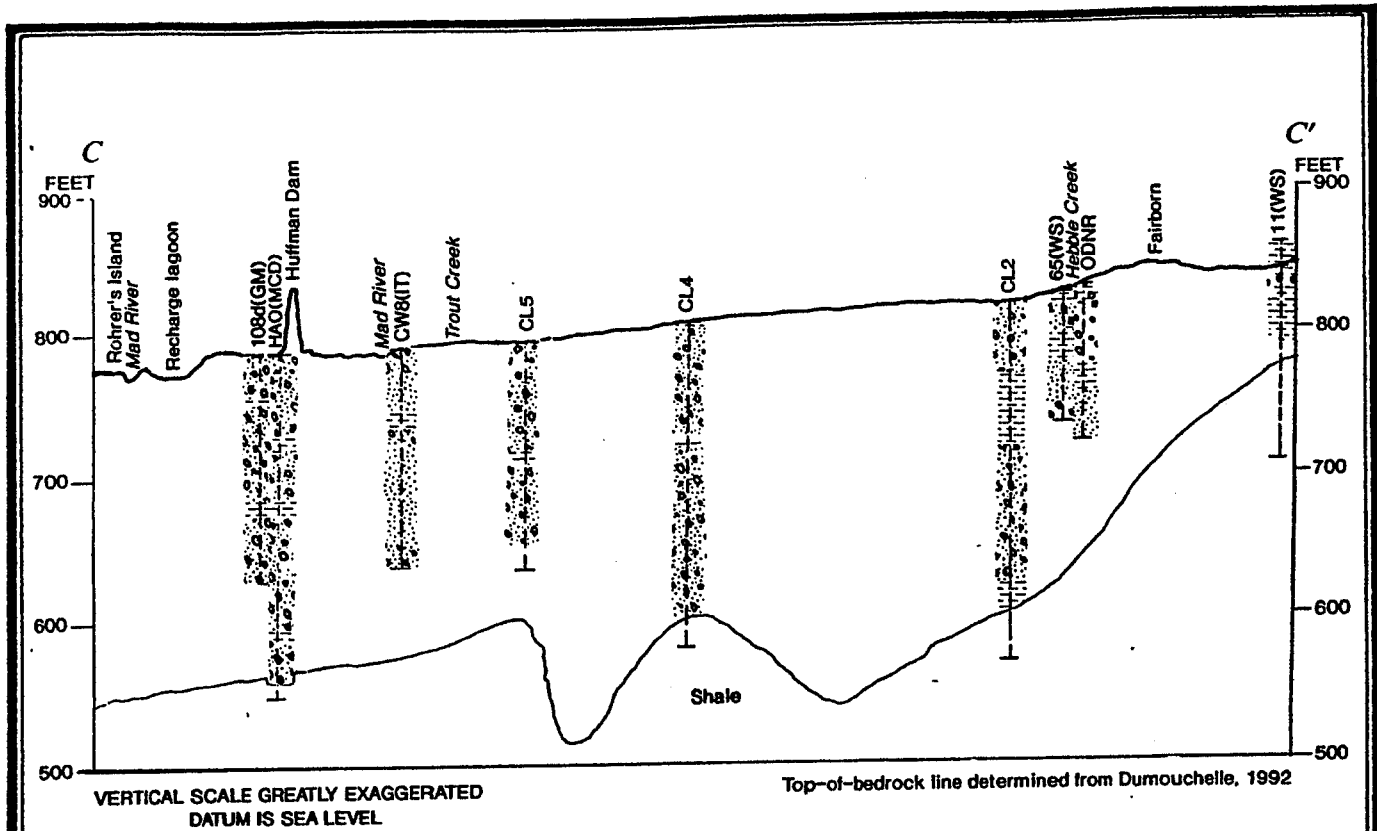

EXPLANATION

- CLAY AND (OR) SILT
- SAND
- GRAVEL

WELL PROJECTED TO GEOLOGIC-SECTION LINE--All within 1,000 feet of section line. The unusual bedrock position in wells HAO, CL5 and 11 are due to the projection of these wells to the line of section

WELL IDENTIFICATION

- 65(WS) Log number in Walton and Scudder (1960)
- CL5 Well-cluster number, wells drilled by U.S. Geological Survey. Location in figure 2 (Dumouchelle and deRoche, 1991)
- ODNR Well log on file with the Ohio Department of Natural Resources, Division of Water
- 108D(GM) Well number in Geraghty & Miller, Inc. (1987)—Clay at approximately 750 feet was not found in 108s, a nearby well
- HAO(MCD) Well number in Miami Conservancy District files
- CWB(IT) Well cluster in IT Corporation (1990)

FIG.4-3 GEOLOGIC SECTION C-C'

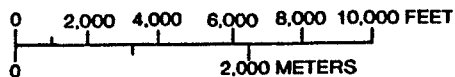

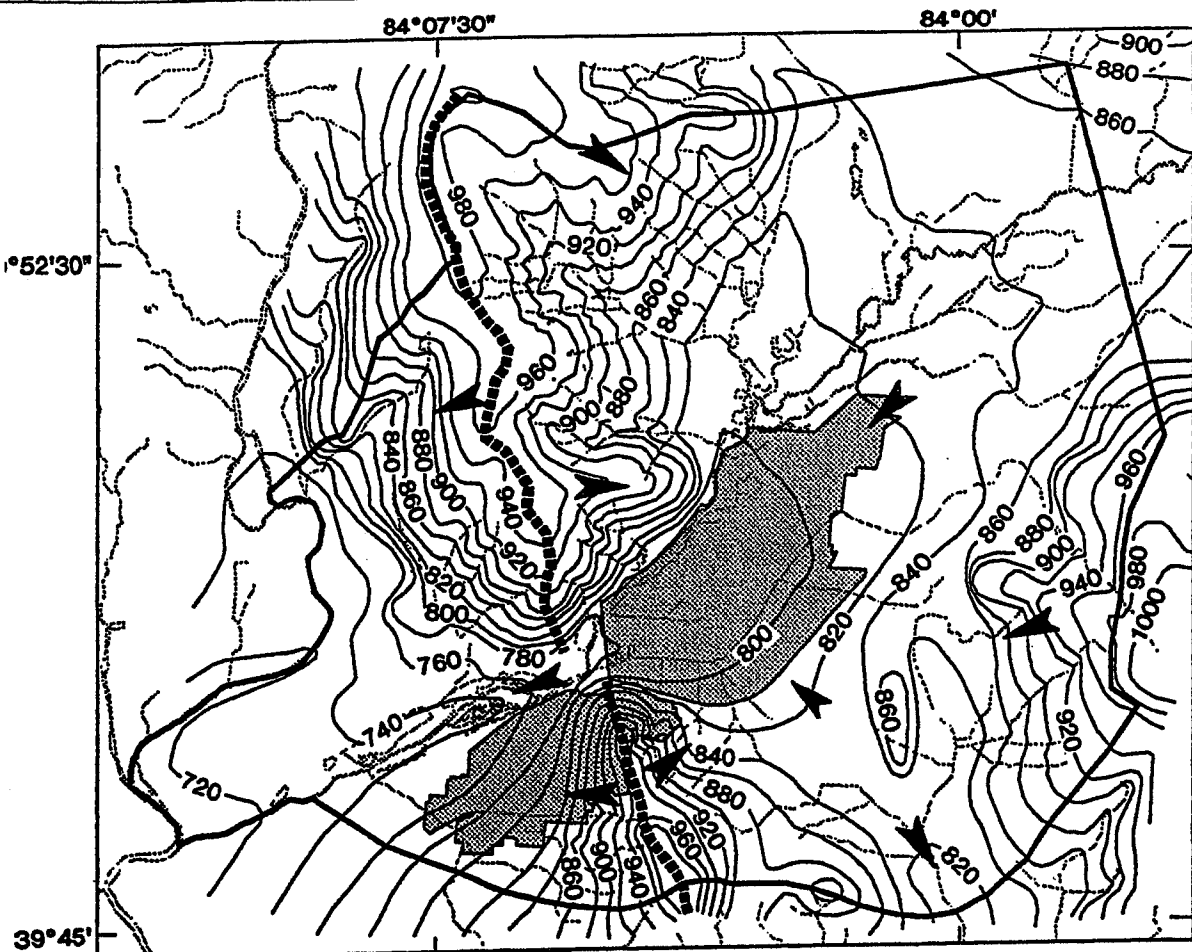

Base map digitized from U.S. Geological Survey
 Bellbrook, 1965, photorevised 1987; Dayton North, 1965, photorevised 1981; Dayton South, 1965, photorevised 1981; Donnelville, 1965, photorevised 1973, photoinspected 1963; Fairborn, 1965, photorevised 1985; New Carlisle, 1955, photorevised 1968 and 1973, photoinspected 1954; Tipp City, 1965, photorevised 1982; Xenia, 1965, photorevised 1987; Yellow Springs, 1968, photorevised 1975.
 Polyconic projection

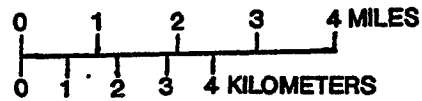

EXPLANATION





-  WRIGHT-PATTERSON AIR FORCE BASE
-  -840- GROUND-WATER-LEVEL CONTOUR--Shows altitude of composite ground-water surface in the uppermost aquifer. Contour interval 20 feet. Datum is sea level
-  MODELED-AREA BOUNDARY
-  LOCAL GROUND-WATER DIVIDE
-  LOCAL DIRECTION OF GROUND-WATER FLOW

FIG. 4-4 GROUNDWATER LEVELS IN THE REGION



VERTICAL SCALE GREATLY EXAGGERATED
DATUM IS SEA LEVEL

Top-of-bedrock line determined from Dumouchelle, 1992

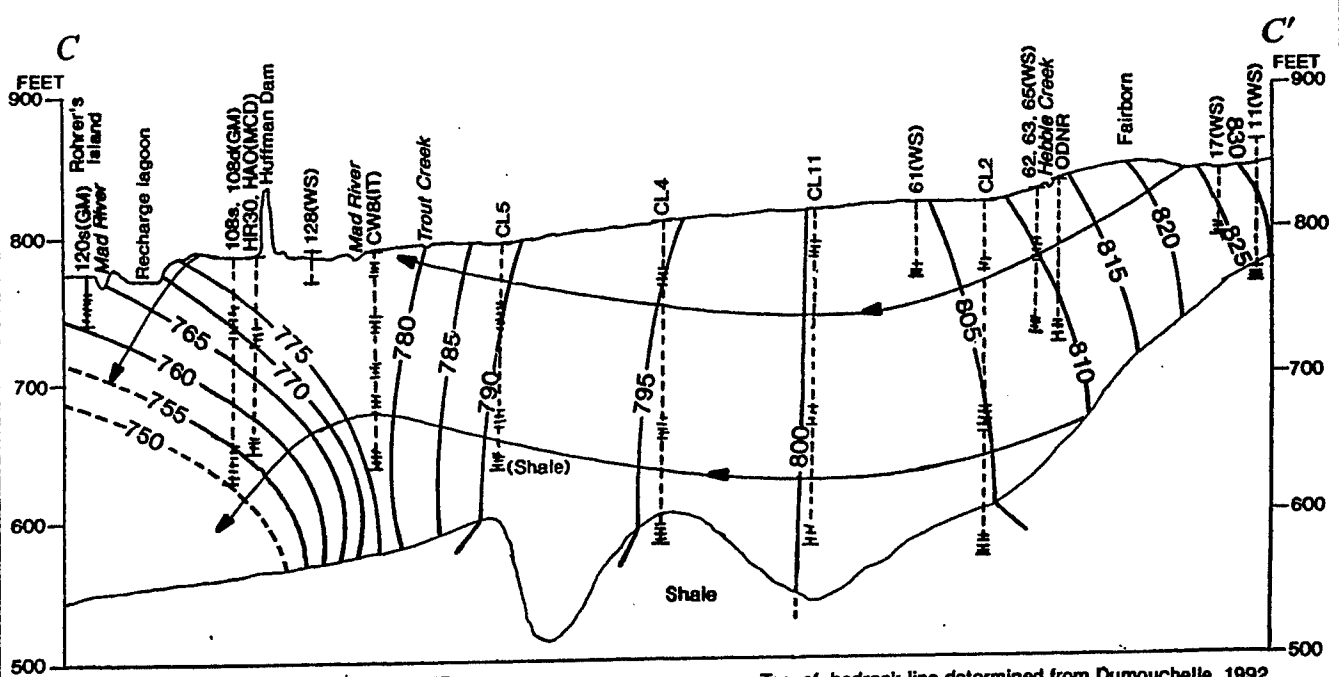
EXPLANATION

- 700— POTENTIOMETRIC LINE—based on measured or reported water levels. Shows altitude at which water-level stands in tightly cased wells
- ← GENERALIZED DIRECTION OF FLOW
- I WELL ON SECTION LINE
- I WELL PROJECTED TO SECTION LINE—All well except cluster 11 are within 1,000 feet of section line. Cluster 11 is 2,200 feet from the section line

WELL IDENTIFICATION	
62(WS)	Log number in Walton and Scudder (1960)
CL5	Well-cluster number, wells drilled by U.S. Geological Survey. Location in figure 2 (Dumouchelle and deRoche, 1991)
ODNR	Well log on file with the Ohio Department of Natural Resources, Division of Water
120s(GM)	Well number in Geraghty & Miller, Inc. (1987)
HR30(MCD)	Well number in Miami Conservancy District files
CW8(IT)	Well cluster in IT Corporation (1960)

FIG. 4-5 GENERALIZED VERTICAL SECTION GROUNDWATER FLOW NET

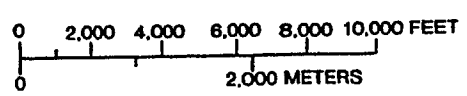

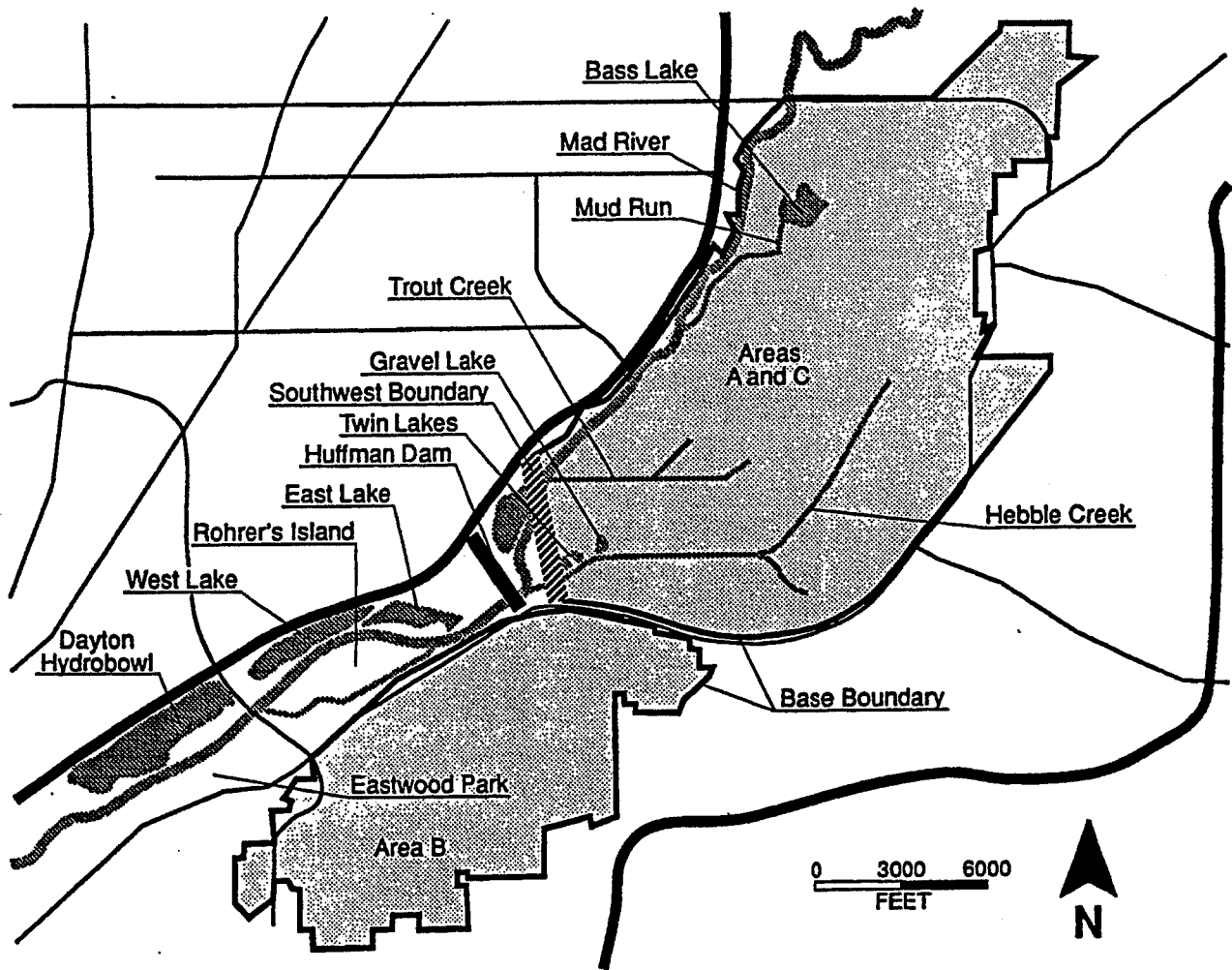

FIG. 4-6 WRIGHT-PATTERSON AIR FORCE BASE WATERSHED

In general, the aquifer has high hydraulic conductivity near the ground surface and less conductivity as depth increases. Hydraulic conductivities of up to 2,500 feet/day are reported in the unconsolidated outwash deposits with corresponding high yields in wells. Recharge of the shallower portions of the aquifer may be in the order of days or weeks, whereas deeper portions may require years or decades for recharge.¹

The aquifer offers sufficient capacity to serve the long-term needs of WPAFB. However, the new wellfield recently brought on line by the City of Dayton may impact the East Wellfield. This wellfield is located just below Huffman Dam and, if heavily pumped, its cone of depression could reach Twin Lakes and the lettered wells.

As related to contaminants, the more permeable upper portions of the aquifer can easily become contaminated by spills or subsurface leakage. However, the associated high hydraulic conductivity of these shallow outwash deposits allows for timely remediation of contamination. Conversely, the deep parts of the aquifer may experience less contamination but, once polluted, remediation will take a long period of time. It is obviously best management practice to remediate spills or leakage as quickly as possible in order to protect the drinking water supply. The USGS report will be used by the Base Environmental Management office to develop a wellhead protection program to conform with OEPA requirements. In addition, much has been done in recent years on the Base to remediate previous spills and leakage and to prevent future occurrences of groundwater contamination.

A list of the production wells at WPAFB is provided in Table 4-1. The wells are in the process of being upgraded with new pumps, well repairs, and casing extension and sealing to meet OEPA classification as groundwater not under the influence of surface water. Table 4-1 lists the anticipated well pumping rates and pump arrangements after the upgrading is completed. The current conditions differ from that shown in the table and may be seen in Appendices entitled "Pump Database" and "Pump Curves" of the Woolpert Consultants' reports.^{4,5} Currently, the East Wellfield is not in operation. Area B wells 1 and 2 are not currently used, except in an emergency, since they are pumping gravel. Well 2 has a single casing with two pumps installed. The upgraded Well 2 will only have one pump. Well 4 is not usable due to well blockage. Well 5 is the main supply source for Area B at the present time.

After the wells are upgraded, Area A will have the least available supply capacity and well selection with only 1,900 gpm available from both Wells 8 and 9. Area C will have a good well selection with Wells 1, 2, 3, and 7 offering a potential capacity of 3,350 gpm or about 4.8 MGD. Area B will have the most redundancy and potential well capacity with Wells 1, 2, 4, and 5 offering 6,500 gpm (9.3 MGD) and the five lettered wells in the East Wellfield each rated for 1,500 gpm. In general,

TABLE 4-1

WPAFB PRODUCTION WELLS

<u>AREA SERVED</u>	<u>DESIGNATION</u>	<u>NUMBER AND SIZE & PUMP(S)</u>
A	Well #8 (Facility #30851)	one-950 gpm**
A	Well #9 (Facility #30852)	one-950 gpm**
B	Well #1 (Facility #20086C)	one-1,100 gpm
B	Well #2 (Facility #20086G)	one-2,000 gpm**
B	Well #4 (Facility #20086B)	one-1,400 gpm
B	Well #5 (Facility #20087)	one-2,000 gpm
B*	Well A	one-1,500 gpm**
B*	Well B	one-1,500 gpm**
B*	Well C	one-1,500 gpm**
B*	Well E	one-1,500 gpm**
B*	Well F	one-1,500 gpm**
C	Well #1 (Facility #30160)	one- 350 gpm
C	Well #2 (Facility #30171)	one- 350 gpm**
C	Well #3 (Facility #30203)	one-1,100 gpm**
C	Well #7 (Facility #30181)	one-1,200 gpm

* *Lettered wells in East Wellfield located in Area C. Water pumped to Area B in the past. Wellfield currently out of use. Well D used for the golf course only. Well E connection to West Ramp (SAC) area has broken piping.*

** *Anticipated pumping rate after rehabilitation in 1994. Pumping rates will be less for more than one pump discharging into a common well collection pipeline.*

Area A is deficient in number of wells and potential capacity, Area C is adequate, and Area B is over supplied (when the lettered wells come back on line).

The Hebble Creek well, Facility #30883, serves only one building, Facility 30886, and this small well is not included in Table 4-1. The well is located along Hebble Creek at the Base Firing Range and will be upgraded to meet OEPA standards (see Appendix B).

Once the wells are upgraded, improvements should be made by the Base in their maintenance. This should include annual amperage and megger testing, scheduled preventative maintenance, and an open-ended contract for rehabilitation support from outside services. Both Dayton and Fairborn have implemented such a program on their wells to increase reliability.

SURFACE WATER

The Mad River, on the northwest boundary of the Base, offers a surface water source of sufficient quantity to supply the 3.6 MGD projected average daily demand of the Base. The average flow of the river, as measured at Huffman Dam, is 407 MGD.⁷ Since 1914, recorded extreme flows are between 61 and 13,695 MGD.⁸ Groundwater discharge to the river is an important source of its perennial flow.

Huffman Dam is operated as a flood control structure and not as a water supply reservoir. There is no large permanent pool of water stored by the dam; allowing the maximum capture of flood water. Although its location is suitable for a Base water supply reservoir (see Figure 4-6), a separate study is necessary to determine if a water intake structure could be located upstream from the dam.

Hebble Creek, Mud Run, Trout Creek, and the lakes on the Base are not thought to have sufficient capacity to supply the daily demand for drinking water. The lakes are all influenced by groundwater flow and gain or lose water level in relation to the local groundwater gradient.¹

The quality of the water in the Mad River is probably satisfactory for treatment by a conventional surface water treatment plant. The river water is often muddy which is indicative of a high sediment load. However, no serious contamination exists as reflected in the generally good water quality at the Roher's Island wellfield. The quality of a surface water supply will vary much more than a groundwater supply. A river supply can be expected to have daily fluctuations in quality depending on flowrates, seasonal effects, and, in particular, spills of contaminants.

A surface water supply is subject to more stringent regulations than a groundwater source and, accordingly, requires a significantly higher level of treatment. The Surface Water Treatment Rule (SWTR) mandates filtration of a surface supply. A new rule, the Disinfectants and Disinfection By-Products Rule (D/DBP Rule), will have much more effect on surface water treatment plants than groundwater facilities. Associated with the D/DBP Rule are the Information Collection Rule (ICR) and the

Enhanced Surface Water Treatment Rule (ESWTR). These three rules were developed by the USEPA in conjunction with water industry groups to manage complicated and technical interrelationships between disinfection by-products and pathogens. The rules seek to reduce health risks at a reasonable cost in the simplest manner possible. The rules will regulate the following:

- D/DBP Rule - regulates disinfectants and their byproducts. Stage 1 applies to groundwater and surface water and requires monitoring, MCLs for certain disinfection by-products, and disinfectant residual limits. Stage 2 is only for surface water systems.
- ESWTR - Expands the current SWTR to include Cryptosporidium organisms.
- ICR - Requires monitoring and treatment data to be used for setting the ESWTR and D/DBP Rule. This rule does not apply to groundwater systems serving less than 50,000 people.

The final details of these three rules are still under negotiation by the water industry and USEPA. The first phase of the rules requires ICR monitoring to commence by January, 1995 for surface water treatment plants serving a population as large as the Base.

Although the Mad River offers an adequate quantity for a Base water supply, the quality issues, the complicated treatment requirements, and the very stringent USEPA rules for surface water providers which are further described in Section 5 are all negative factors when considering a surface water source. The abundance of groundwater under the Base, the ease of extracting the water, and the reasonable treatment requirements make groundwater the most economical water source for the Base.

PURCHASED WATER

Dayton- Currently there is only one area on the Base served with water by an off-Base supplier. This family housing area, Page Manor, is located across Col Glenn Highway from Area B, and receives its drinking water from the City of Dayton through the Montgomery County water distribution system. There is no interconnection between Page Manor's water system and the Base system.

The City of Dayton softens its groundwater prior to distribution. This is one of the main reasons that Page Manor receives City water. However, the purchased price for the water is high since Montgomery County adds a surcharge to Dayton's water charges. The WPAFB Water Treatment Task Force⁹ calculated a savings of \$291,000 per year if Page Manor was connected to the Area B system.

The Task Force also considered supplying all of Area B with the City of Dayton water. Area B water is distributed by pumps and gravity from the ground

level storage reservoirs next to Building 20085A. The closest point in the Dayton system that may be capable of supplying the flow and pressure requirements of the Base are at Irwin and Springfield Streets or Smithville and Burkhardt Streets. Either of the locations will require about 16,800 linear feet of 16-inch water line to connect to Area B at Building 20085A. This line must be constructed through populated areas and across Col Glenn Highway, a major road, to reach the Base. Construction costs under these conditions can be expected to be substantial, but a detailed feasibility study would be necessary to determine these costs based on water main locations.

The Task Force found that purchased water for Area B would cost more than using the existing wells and treatment system. Although there are qualitative advantages to using purchased water, they may not be substantial enough to warrant the additional expenditures.

It would be possible, through the use of the existing 24-inch line under SR 444 and the Conrail tracks and through additional water main construction, to supply Areas A and C along with Area B with City of Dayton water. However, the economics of this scenario are greater in cost than for serving Area B by itself and are therefore not considered feasible.

The Dayton Water Department has recently commenced water service to a large area on the south side of the City. Although excess treatment capacity is available, the City is limited in its present supply capacity. The City has purchased land and is in the process of developing a new wellfield north of the Base. When this new wellfield comes on line, the City would be able to serve WPAFB.

Fairborn - The City of Fairborn borders the east side of the Base and has three existing connections with the Base water system. All of these connections are small (6-inch) and could supply only a limited amount of water. The connections are probably intended for emergency usage and have seldom, if ever, been used.

The connections are all in the same general vicinity on the east side of Area C. One connection is just east of Building 30089 near Gate 35C, a second connection is north of the first near Building 30016, and the third connection is further north adjacent to the tank farm. The Fairborn system is hydraulically strong in this area with a 500,000 gallon elevated tank and a 24-inch line installed four years ago on Pierce Drive.

Fairborn has recently expanded its water treatment plant to process a peak flow rate of 9.2 MGD. The City uses about 3.4 MGD on an average day and 4.0 MGD in summer. The additional plant capacity is expected to serve projected growth for the next 15 years. The treatment plant removes iron from the well water supplied to it by the wellfield located to the north of the Base along the Mad River. No softening of the water is currently performed or proposed to be added in the future.

The City is willing to discuss supplying the Base with drinking water. However, projected rates and costs for capital improvements are not available at this

time. Since the Fairborn water is not softened, there is no quality improvement to the Base over its existing drinking water.

Other Water Systems - Wright State University and Green County each have water systems bordering WPAFB. Both systems are too small in capacity to provide any purchased water to the Base.

SUMMARY

WPAFB is in the unique position of having several options to supply its current and projected demands. Groundwater is the current source, but the potential exists to develop a surface water supply as well as purchase water from surrounding municipalities. Based only on quantitative issues, maintaining and improving the groundwater source appears to be the most viable option. The aquifer is hydraulically sufficient even though heavily used by the Base and its neighbors. Purchasing water from Dayton would be very expensive, but should be explored in more detail. Additional interconnections with the Fairborn system would be beneficial for emergency conditions and a purchase option may be worth investigating further. Developing a surface water source would involve a substantial investment in time and money which is not considered to be justified given the other available options.

SECTION 5

QUALITATIVE ANALYSIS OF SUPPLY OPTIONS

GENERAL

The Safe Drinking Water Act (SDWA) Amendments of 1986 were an attempt by Congress to strengthen the original SDWA legislation enacted in 1974. Many of the sections were revised and new ones added in response to limitations identified during that 12 year period, especially relating to the regulation setting process and groundwater protection. Salient features of the amendments include:

- Maximum contaminant level goals (MCLGs) and maximum contaminant levels (MCLs) are to be established by USEPA for 83 specific contaminants and for any other contaminant in drinking water which may adversely affect human health and is known or anticipated to occur in public water supply systems. MCLGs are to be set at a level at which no known or anticipated human health effects will occur, allowing an adequate margin of safety. MCLs must be set as close to the goal as is feasible, depending on the use of the best technology, treatment, and laboratory analytical methods.
- Volatile organic chemicals (VOCs), synthetic organic chemicals (SOCs), inorganic chemicals (IOCs), microbiological contaminants, and radionuclides are included in the original list of the 83 contaminants as presented in Table 5-1.
- Seven substitutes to this list are allowed if USEPA determines a contaminant has more important public health considerations than those originally specified.
- Best available technology (BAT) and monitoring requirements are to be set for the 83 contaminants. Granular activated carbon is specified as BAT for SOCs.
- Filtration is required for surface water suppliers, with certain exemptions.
- Disinfection is required for all water supplies, with regulation of disinfection by-products.
- Use of lead products in all drinking water conveyances is prohibited.
- Groundwater sources are to be protected by establishing wellhead protection area programs.

TABLE 5-1

CONTAMINANTS REQUIRED TO BE REGULATED
UNDER THE SDWA AMENDMENTS OF 1986

Volatile Organic Chemicals

Trichloroethylene	Benzene
Tetrachloroethylene	Chlorobenzene
Carbon tetrachloride	Dichlorobenzene
1,1,1-Trichloroethane	Trichlorobenzene
1,2-Dichloroethane	1,1-Dichloroethylene
Vinyl chloride	<i>trans</i> -1,2-Dichloroethylene
Methylene chloride	<i>cis</i> -1,2-Dichloroethylene

Microbiology and Turbidity

Total coliforms	Viruses
Turbidity	Standard plate count
<i>Giardia lamblia</i>	<i>Legionella</i>

Inorganics

Arsenic	Molybdenum
Barium	Asbestos
Cadmium	Sulfate
Chromium	Copper
Lead	Vanadium
Mercury	Sodium
Nitrate	Nickel
Selenium	Zinc
Silver	Thallium
Fluoride	Beryllium
Aluminum	Cyanide
Antimony	

TABLE 5-1 (Continued)

Synthetic Organic Chemicals

Endrin	1,1,2-Trichloroethane
Lindane	Vydate
Methoxychlor	Simazine
Toxaphene	PAHs
2,4-D	PCBs
2,4,5-TP	Atrazine
Aldicarb	Phthalates
Chlordane	Acrylamide
Dalapon	Dibromochloropropane (DBCP)
Diquat	1,2-Dichloropropane
Endothall	Pentachlorophenol
Glyphosate	Pichloram
Carbofuran	Dinoseb
Alachlor	Ethylene dibromide (EDB)
Epichlorohydrin	Dibromomethane
Toluene	Xylene
Adipates	Hexachlorocyclopentadiene
2,3,7,8-TCDD (Dioxin)	Total Trihalomethanes (TTHM)

Radionuclides

Radium 226 and 228 Beta-particle and photon radioactivity Uranium	Gross alpha-particle activity Radon
--	--

- States must adopt all national primary drinking water regulations promulgated by USEPA within 18 months to maintain primary enforcement responsibility (primacy).

A timeframe was also established to provide a phased approach for regulating the contaminants. MCLGs and MCLs for VOCs and SOCs were to be promulgated first, followed by those for inorganic and microbial contaminants, radionuclides, and disinfection by-products.

USEPA - OEPA REQUIREMENTS

Initial action on VOCs occurred in 1989 when USEPA set the MCLG on five suspected or known human carcinogens at zero. Taking into consideration the level of detection that could be routinely achieved by laboratories, the MCLs were set somewhat higher. It is anticipated that as laboratory procedures become more sophisticated these MCLs may be lowered. USEPA also determined the BAT for VOCs are packed-tower aeration and/or adsorption using granular activated carbon since VOCs are generally lightweight organic compounds that vaporize or evaporate easily. Although at first VOCs were primarily a concern in surface water, it has quickly become apparent that a considerable amount of groundwater has been contaminated due to spills, poor storage, and haphazard disposal methods. Groundwater does not have the advantages of dilution and natural aeration found with surface waters. Once contaminated, VOCs may therefore remain in a groundwater supply for a very long time.

Ohio is a primacy state for the enforcement of SDWA regulations. WPAFB must comply with primary drinking water rules for Ohio public water systems and report monitoring data to the OEPA. Monitoring is being performed in accordance with these rules by Bioenvironmental Engineering personnel and reports are submitted to OEPA by the Environmental Management office. Current MCLs established by the Ohio Administration Code, effective 13 September 1993, are presented in Tables 5-2 for VOCs, Table 5-3 for SOCs, Table 5-4 for inorganic contaminants, and Table 5-5 for microbiological contaminants and radionuclides.

The microbiological contaminants are of particular concern to WPAFB since some wells in the East Wellfield have tested positive for coliform during past monitoring. These wells are presently considered under the influence of surface water due to the positive test results. After the wells are modified to conform to OEPA requirements (Appendices B and C), the Base will have to obtain four calendar quarters of negative microbiological testing to prove that the wells are not influenced by surface water.

It is not anticipated that these regulations will change or that new contaminants will be added in the near future. Reauthorization of the SDWA appears to be on the back burner as Congress contends with other issues. The water supply community

TABLE 5-2

OHIO MCLs FOR VOLATILE
ORGANIC CHEMICALS

<u>Contaminant</u>	<u>MCL</u> <u>($\mu\text{g/L}$)</u>
Vinyl chloride	2
Benzene	5
Carbon tetrachloride	5
p-Dichlorobenzene	75
1,2-Dichloroethane	5
1,1-Dichloroethylene	7
Trichloroethylene	5
1,1,1-Trichloroethane	200
o-Dichlorobenzene	600
cis-1,2-Dichloroethylene	70
trans-1,2-Dichloroethylene	100
1,2-Dichloropropane	5
Dichloromethane	5
Ethylbenzene	700
Monochlorobenzene	100
Styrene	100
Tetrachloroethylene	5
Toluene	1,000
1,2,4-Trichlorobenzene	70
1,1,2-Trichloroethane	5
Xylenes (total)	10,000
Trihalomethanes (total) *	100

* *The sum of the concentrations for:*
Bromodichloromethane
Dibromochloromethane
Bromoform
Chloroform

TABLE 5-3

OHIO MCLs FOR SYNTHETIC
ORGANIC CHEMICALS

<u>Contaminant</u>	<u>MCL</u> <u>($\mu\text{g/L}$)</u>
Alachlor	2
Atrazine	3
Benzo[a]pyrene	0.2
Carbofuran	40
Chlordane	2
2,4-D	70
Dalapon	200
Dibromochloropropane (DBCP)	0.2
Di(2-ethylhexyl) adipate	400
Di(2-ethylhexyl) phthalate	6
Dinoseb	7
Diquat	20
Endothall	100
Endrin	2
Ethylene dibromide (EDB)	0.05
Glyphosate	700
Heptachlor	0.4
Heptachlor epoxide	0.2
Hexachlorobenzene	1
Hexachlorocyclopentadiene	50
Lindane	0.2
Methoxychlor	40
Oxamyl (Vydate)	200
Picloram	500
Polychlorinated biphenyls (PCBs)	0.5
Pentachlorophenol	1
Simazine	4
2,3,7,8-TCDD (Dioxin)	3×10^{-5}
Toxaphene	3
2,4,5-TP (Silvex)	50

TABLE 5-4

OHIO MCLs FOR INORGANIC CONTAMINANTS

<u>Contaminant</u>	<u>MCL ($\mu\text{g/L}$)*</u>
Antimony	6
Arsenic	50
Asbestos	7**
Barium	2,000
Beryllium	4
Cadmium	5
Chromium	100
Cyanide (as free cyanide)	200
Fluoride	4,000
Mercury	2
Nickel	100
Nitrate (as N)	10,000
Nitrite (as N)	1,000
Total nitrate and nitrite (as N)	10,000
Selenium	50
Thallium	2

* *Unless otherwise noted*

** *Millions of fibers per liter, where only fibers longer than 10 micrometers are counted*

TABLE 5-5

OHIO MCLs FOR MICROBIOLOGICAL
CONTAMINANTS AND RADIONUCLIDES

<u>Contaminant</u>	<u>MCL</u>
Total Coliforms	*
Turbidity	**
Radium 226 and 228	5 Pci/L
Gross alpha particle activity	15 Pci/L

* *Less than 5 percent of samples coliform-positive for systems that monitor 40 or more samples per month. Not more than 1 coliform-positive sample for systems that monitor less than 40 samples per month.*

** *Only applicable to surface water supplies and groundwater supplies under the influence of surface water. Filtration and disinfection are required. Turbidity levels dependant on type of filtration.*

and consumers have realized that the cost of compliance with these regulations is enormous, not to mention expenses resulting from the Surface Water Treatment Rule, the Total Coliform Rule, and the Lead and Copper Rule. Additional monies are still to be spent on the Disinfectants and Disinfection By-Products Rule, the Information Collection Rule, and the Enhanced Surface Water Treatment Rule. Some states have even given up primacy when their legislatures refused to enact USEPA's requirements. The common opinion appears to be that we have reached the point where costs are far greater than the benefits being received.

Base personnel have been actively monitoring the wells and distribution systems in compliance with OEPA requirements. The latest test results (November, 1993) indicate that the MCL of 5 $\mu\text{g/L}$ for tetrachloroethylene is exceeded at Area C Wells 1, 2, 3, and 7 and upstream of both Area C air strippers, with the highest readings at Wells 1 and 2 (27.8 and 28.1 $\mu\text{g/L}$, respectively). Trichloroethylene results at Areas A Wells 8 and 9, as well as upstream of both Area A air strippers, are close to the MCL for that parameter, as are vinyl chloride results at Wells C and E in the East Wellfield. The tetrachloroethylene levels in Area C Wells 1, 2, 3, and 7 and the trichloroethylene levels in Area A Wells 8 and 9 are consistent with previous analyses. Trichloroethylene levels at the Area B wells and air strippers have been reported as exceeding the MCL of 5 $\mu\text{g/L}$ by OEPA (Appendix B). Recent testing indicates that the levels are currently less than half of the MCL. This change could be the result of a variety of reasons, including the increased use of Well #5. Distribution system analyses for each Area indicate results well below MCLs for all primary contaminants. These results demonstrate that the air strippers are performing in a satisfactory manner; vaporizing the VOCs in the raw water and discharging them to the atmosphere. Since the raw water VOC content is relatively low and the volume of forced air through the air strippers dilutes the vapors being created, it is not anticipated that the air emissions will require any treatment. However, each stripper is registered with the Regional Air Pollution Control Agency to comply with Ohio regulations.

Table 5-6 presents the secondary MCLs established by the Ohio Administrative Code. Secondary MCLs are the advisable maximum levels of contaminants supplied to a drinking water customer. They are mainly aesthetic considerations which relate to the customer's acceptance of the water for drinking or other uses. WPAFB water has a high dissolved solids level with most of the wells exceeding the secondary MCL for TDS. All of the other secondary MCLs have little impact on the wells currently supplying the Base. However, the lettered wells in the East Wellfield have reported high iron and manganese levels (Appendix F). Iron and manganese at levels above their respective secondary MCLs will stain laundry, plumbing, or anything else that comes into contact with the water. Additional treatment may be required when the rehabilitation of these wells is completed.

The SDWA Amendments also provided a program which was intended to protect the groundwater supplies of public water system wells. OEPA has endorsed

TABLE 5-6
OHIO SECONDARY MCLs

<u>Contaminant</u>	<u>MCL</u>
Aluminum*	0.05 to 0.2 mg/L
Chloride	250 mg/L
Color	15 color units
Corrosivity	non-corrosive
Fluoride	2.0 mg/L
Foaming Agents	0.5 mg/L
Iron	0.3 mg/L
Manganese	0.05 mg/L
Odor	3 threshold odor number
pH	7.0-10.5
Silver	0.1 mg/L
Sulfate	250 mg/L
(TDS)	500 mg/L
Zinc	5 mg/L

* *The secondary maximum contaminant level for aluminum is a range, with the precise level applicable to each public water system to be determined by the director.*

this wellhead protection program on a site-specific basis rather than establishing the following general criteria contained in the SDWA:

- outline the roles of state, local, and public water supply agencies in carrying out the program,
- determine wellhead protection areas for each well or wellfield supplying a public water system,
- identify all man-made, potential contamination sources within each wellhead protection area,
- describe a plan to protect the wells from contamination, including technical assistance, training, control measures, or financial assistance,
- provide contingency planning to ensure safe drinking water in the event that a supply becomes contaminated,
- require that potential sources of contamination be investigated before a new well is constructed.

A wellhead protection area is defined as the surface and subsurface area surrounding a well or wellfield. The size of this area will depend on hydrogeological factors, such as the radius of influence. This is an important concept for WPAFB due to the many industrial activities that occur on-Base and in the surrounding area. OEPA has recommended several measures in this regard (Appendix B) which are currently being addressed by the Base (Appendix C).

TREATMENT ISSUES

For groundwater supplies, treatment is required to comply with the primary MCLs and is suggested for the secondary MCLs. Disinfection is also required, even if the groundwater has total coliforms below the MCL. The treatment processes currently used at all Areas of WPAFB employ generally accepted techniques for the removal of those primary contaminants which have been detected in the groundwater. Unless the VOC levels increase substantially, packed tower air stripping with scale control and disinfection should provide a reliable means of protecting the drinking water distributed to Base consumers. Increasing VOC concentrations in the groundwater may eventually cause the need to address whether the VOCs exiting in the air discharged from the packed tower constitute a health risk. This will become an Area-specific decision based on the proximity of the units to people, wind patterns, VOC concentration, and air volumes. Should air pollution controls be required, such as passing the air flow through activated carbon canisters, capital and operating costs for these units will significantly increase. Depending on the age and relative efficiency of the packed towers in removing specific VOCs in the groundwater at that time,

the packed towers in removing specific VOCs in the groundwater at that time, granular activated carbon vessels may be installed as replacements. This change would be a major capital investment for the Base (about \$750,000 to \$1,000,000), involve a pretreatment step (possibly filtration), and add the operating expenses associated with carbon replacement and disposal.

There are three general methods used for the treatment of iron and manganese which are above the secondary MCLs in the East Wellfield:

- precipitation and filtration
- ion exchange
- stabilization with polyphosphates

The last two methods have restrictions which would limit their effective use at the Base over a prolonged period. At combined metal concentrations above 0.5 mg/L, which is the case at the East Wellfield, fouling of an ion exchange medium is likely and polyphosphate dosages may be higher than the recommended 10 mg/L to maintain a phosphorous concentration in the drinking water below the required 1 mg/L level. Precipitation and filtration would therefore be the recommended treatment for raw water from the East Wellfield. Precipitation is traditionally accomplished by aeration and detention (or sedimentation), a practice employed locally by the City of Fairborn and Greene County water treatment plants. Other methods of precipitation include oxidation using potassium permanganate, chlorine, and chlorine dioxide; biologically active filters; oxygen injection to the aquifer; and green sand filters. If precipitation and filtration are used to remove the iron and manganese, it may be logical to also provide a lime-soda ash softening process for hardness and TDS reduction. This would add to the cost of treatment and the complexity of operation, but would help insure a better water quality.

Treatment issues are significantly more complex for public water supplies using surface waters as a source. As discussed in Section 4, Quantitative Analysis of Supply Options, the Surface Water Treatment Rule mandates filtration of a surface supply and three other rules will soon be implemented which apply directly to this source. OEPA regulations stipulate both filtration and disinfection as treatment techniques in lieu of establishing MCLs for the Microbiology and Turbidity contaminants listed in Table 5-1. Water treatment processes must be installed and properly operated to reliably achieve:

- at least 99.9 percent (3 log) removal and/or inactivation of *Giardia Lamblia* cysts between a point where the raw water is not subject to recontamination by surface water runoff and a later point before or at the first customer, and

- at least a 99.99 percent (4 log) removal and/or inactivation of viruses under these same conditions.

Conventional, direct, and slow sand filtration, as well as other filtration technologies that can be demonstrated to produce these removals, are major capital expenditures that WPAFB would incur if the raw water source was switched to a surface supply. In addition, a central plant may be determined as the most cost-effective collection and treatment approach, even though it would entail new water mains to combine the Area A, B, and C distribution systems. Compliance with surface water treatment regulations would also significantly increase operating costs. From a quality standpoint, however, a properly operated central plant for treating surface water would have several advantages over the current system:

- consistency in the water supplied to all Areas of the Base,
- capability to economically soften all Base water, and
- easier response to changing source conditions and regulatory rules.

SECTION 6

VULNERABILITY ANALYSIS

EMERGENCIES

An emergency can affect a water utility at any time, day or night, and, in some cases, with little or no advance warning. The utility management must be able to react with the necessary response to ensure the safety and availability of the potable water supply. The utility must be prepared for emergencies to occur through the process of emergency water planning. The OEPA, by legal mandate of the SDWA, required WPAFB to develop a water system contingency plan. In addition, AFR 160-25, Medical Readiness Planning and Training, includes a requirement for water vulnerability studies.

This section contains a water facilities orientated vulnerability analysis of the WPAFB water systems. The analysis will consider the effects of an emergency on all parts of the water systems including: well supplies, treatment, distribution, and domestic and fire storage. The redundancy of facilities and the availability of standby systems is of major concern in the analysis. The ability of the water system to maintain adequate pressure for domestic demand and fire flows is evaluated for the various emergency conditions. Deficiencies of the existing water systems that impede emergency performance become evident through the vulnerability analysis. Recommendations to reduce vulnerability are included herein.

Applicable references for this vulnerability analysis include AWWA Manual M19¹⁰ and Water Vulnerability Assessments¹¹ by Armstrong Laboratory. Armstrong Laboratory refers to the Air Force Energy Vulnerability Assessment Guide which includes contingency planning for water systems using a six-phased process. Portions of Phases II, III, and IV are used for this analysis.

TYPES OF EMERGENCIES

Water utility personnel at the Base are well prepared to deal with the routine type of emergency that can occur. These routine emergencies include broken pipes, inoperable valves, sheared off fire hydrants, malfunctioning treatment equipment, and a variety of related problems. When these routine emergencies take place outside of normal working hours, key personnel must be recalled to effect repairs and do whatever else is necessary to maintain water system operation. The training and experience obtained by water utility personnel in dealing with these routine emergencies will be of considerable value when contending with non-routine emergencies.

Non-routine emergencies are generally related to natural or manmade disasters. Some disasters can be predicted ahead of time to allow utilities personnel a window of opportunity to prepare their response. Sudden disasters may be much more difficult to deal with depending on their magnitude and the particular effect on the water system. Table 6-1, as taken from AWWA M-19¹⁰ considers the effect a disaster may have on items impacting water systems.

Some of the listed disasters will never occur at WPAFB's location and others, including ice and snow storms, may likely happen. The potential natural and manmade disasters that could occur at the Base are discussed in more detail herein.

POTENTIAL NATURAL DISASTERS

WPAFB is subject to the following natural disasters:

- Flooding in Areas A and C due to the backwater from Huffman Dam on the Mad River. The dam protects Area B from flooding by the river.
- Tornadoes are unpredictable, but most likely to occur in spring and summer. Damage can be very localized or extremely widespread.
- Severe thunderstorms in summer.
- Windstorms.
- Ice storms or excessive snow falls in winter months.
- Earthquakes are extremely rare and should only cause minor damage in the seismic zone that WPAFB is located in.
- Hurricanes can track this far inland from the Atlantic Ocean. High winds and torrential rain may result.

Tornado. Probably the worst natural disaster that could affect WPAFB is a strong tornado that follows a wide path for a considerable distance along the ground. Buildings can be heavily damaged, water towers may collapse, and water system operations could be severely impacted. Fortunately, such an event is very uncommon and may never occur.

TABLE 6-1

INTERRELATIONSHIP BETWEEN DISASTERS AND THEIR EFFECTS

Effect	Disaster													
	Hurricane	Tornado	Bomb blast	Earthquake	Flood	Explosions of cargo ships, oil tanks, etc.	Plane crash	Civil disorder	Epidemic	Biological warfare	Volcanic dust	Nuclear fallout	Industrial discharge	Accidental spills of hazardous materials
Structural damage	•	•	•	•	•	•	•	•						
Water/sewer lines broken	•	•	•	•	•		•							
Storage tanks destroyed or contaminated	•	•	•	•	•									
Power lines down	•	•	•	•	•									
Access limited by debris	•	•	•	•	•									
Fires						•	•	•						
Water pollution						•	•	•		•	•		•	•
Power outages						•	•	•					•	
Disease								•	•					
Air pollution										•	•	•	•	•
Land contamination										•	•	•	•	•
Taxing of chlorination facilities										•	•	•	•	•

Flooding. Flooding of the lower elevations of Areas A and C is a distinct possibility since Huffman Dam is a flood control structure. The amount of damage is directly proportional to the magnitude of the flood. A flood reaching the 100 year flood elevation of 818.6 will make the East Wellfield inaccessible and severely disrupt Base operations in Areas A and C. Larger floods, such as the 1913 flood that prompted the construction of Huffman Dam (Appendix A), will cause even greater damage and disruption.

Storms. Ice storms, major snowfalls, windstorms, and severe thunderstorms are the most likely natural disasters to occur at WPAFB. Any of these events can result in significant power outages and difficulty in accessing the Base. Ice storms, in particular, can be devastating to overhead electrical power systems and cause long-term outages over large geographical areas.

POTENTIAL MANMADE DISASTERS

WPAFB is subject to the following manmade disasters:

- Spillage of groundwater contaminants from trucks, aircraft, below ground or above ground tanks, broken pipelines, or other sources.
- Biological/chemical sabotage by enemy or terrorist actions.
- Terrorist or enemy bombing (e.g., timer activated plastic explosives).
- Nuclear warfare since the Base is an important Air Force installation.

Spills. A possible manmade disaster that could occur at WPAFB is a major spill of a toxic chemical or petroleum product in a recharge area of a well or well-field. Due to the shallow (50 to 80 feet) depth of the wells and the high permeability of the soils at many places on the Base, the groundwater can easily become contaminated. Such an occurrence could result in portions of the aquifer becoming unsuitable for drinking water if the spill cannot be easily and readily contained.

Wells sited on a contaminated aquifer will be unusable for long periods of time and new wells will have to be installed to ensure an adequate water supply. Locating an aquifer of suitable quantity and quality, obtaining regulatory approvals, installing wells into the aquifer, and constructing collection pipelines can be a time consuming process. Until the new wells are brought on line, the affected Area of WPAFB would be vulnerable due to a lack of supply capacity.

Sabotage. As evidenced by the World Trade Center bombing, the United States is now vulnerable to acts of extremist groups who will create disasters to advance their cause. Prior warnings of time and location for bombings and similar actions may be non-existent. Terrorist actions by enemies or extremist groups could

result in contaminations of the water system by biological or chemical substances, or bombing of the water facilities.

By having three separate water systems, the Base offers a difficult target for sabotage. Sabotage would have to be well coordinated and effectively carried out to disable all of the systems simultaneously.

If Area A was disabled, Area C could be used to supply Area A or vice versa if Area C was disabled. Since sabotage is a localized act, it is not likely that the Fairborn water system would be affected. Area C and, eventually, Area A could obtain water from the three interconnections with the Fairborn system. In addition, the 300,000 gallon ground level storage tank on the West Ramp offers a source of uncontaminated water since it is valved off from the system.

Area B does not have any interconnections with local water purveyors and cannot be supplied with water from Area A or C. Elevated storage Towers #2 and #9 are normally valved off from the system and can temporarily offer a source of clean water to the low zone.

If the sabotage includes widespread arson in conjunction with disabling water systems, a serious situation could occur if the conflagrations are not controlled before water storage facilities are emptied. The Fairborn interconnection offers a limited amount of fire flow to Area C. Bass Lake could be used to fight fires in the West Ramp. Small ponds on the golf course could provide some water for local structures in Area A.

Area B does not have any interconnections or lakes from which to draw fire flow water. Storage is large in this Area, but once the stored water sources are drained fires would be difficult to control.

Nuclear Warfare. Emergency measures depend on the magnitude of a nuclear explosion and its proximity to the Base. A direct hit obviously negates any need for water. The groundwater supply would not be readily contaminated by nuclear warfare and, if any wells are operable, limited amounts of water may be available for human consumption.

EMERGENCY PLANNING

The following are some general considerations for emergency planning to sustain water system operations at WPAFB. Certain infrastructure deficiencies become apparent when analyzing these considerations and the previous information on natural and manmade disasters. Recommendations to correct the deficiencies are presented later in this section.

General Description. WPAFB has a water system in each of its three Areas; A, B, and C. Area B is separated from Areas A and C by a major state highway (SR444) and its system is completely independent of the other areas. Areas A and C are adjacent to each other and their distribution systems can be interconnected.

Groundwater is the supply source for all Areas of the Base. Treatment is the same in each Area and consists of polyphosphate addition to condition the wellwater, air stripping for VOC removal, chlorination, and carbon dioxide injection. Housing areas receive water which is softened by ion exchangers and then fluoridated.

One housing area, Page Manor, receives softened water from the City of Dayton. Figures 2-7, 2-8, and 2-9 describe the Base water systems schematically.

Supply Sources. Each Area has its own wells. Some are not currently usable. A 1994 project will repair and upgrade the wells, including all wells in the East Wellfield. Wells pump the groundwater to the treatment facilities in their respective Areas.

Treatment. Groundwater is pumped by the well pumps through the dual air strippers in each Area. Polyphosphate is added prior to air stripping and chlorine and carbon dioxide are added after. The treated water is piped to ground level reservoirs.

Distribution. Potable water is distributed to the low zone of Area B by gravity. All of Areas A and C and the high zone of Area B require pumping from the ground level reservoirs. Water softened by ion exchangers is distributed separately from non-softened water. Area A can be supplied by Area C and vice versa should the need arise. Normal operation is for Area A and C to have separate distribution, except for one small interconnection.

Dayton city water is distributed to Page Manor via the Montgomery County water distribution system.

Storage. Area B ground level storage can supply the low zone by gravity. All other ground level storage must be pumped into the distribution system. Four diesel driven fire pumps can be used on an emergency basis to supply Area A. Four electrically driven fire pumps supply the low zone of Area B along with the two fire storage towers. Fire pumps in Area C are dedicated to protecting hangars and related activities on the East Ramp and West Ramp (SAC). All Areas have elevated storage towers.

Power. Dayton Power & Light Company supplies the Base with electrical power. Recent improvements to its system have made the power supply very reliable.

Emergency Power. Wells 8 and 9 supplying Area A each have permanently installed standby electrical generators. Pumphouse 20085 has a large portable generator to power fire pumps and a small permanently installed generator to power lighting, controls, and chemical feed pumps.

Emergency Materials and Supplies. Civil Engineering has stockpiled pipe, valves, fire hydrants, repair clamps, and related distribution system materials. These items are stored at Building 30022 in Area C, Building 20085 in Area B, and other locations. Chlorine cylinders are stored at each Area's pumphouse and at Base Supply, Building 30157.

Personnel. The Liquids Flight Section of Civil Engineering is responsible for maintenance and operation of the water system. Mr. Taylor has overall responsibility for the section. Mr. Bundy is in charge of the water treatment facilities in all three Areas. Mr. Hollingsworth is responsible for the Area B water distribution piping and Msgt Laroche is in charge of Areas A and C. Refer to Table 6-2 for details.

- Field crews perform routine O&M including repair of emergency water main breaks, minor repair of treatment facilities and pump maintenance.
- Major work is performed by outside contractors.

Civil Engineering maintains a telephone recall system to contact key personnel.

Communications. Normal communication is via telephone. In addition, most trucks are radio controlled. Supervisory personnel carry personal pocket pagers.

Emergency Plans. The following emergency plans are available for WPAFB:

- Spill Response Plan - provides for emergency clean-up of contaminant spills.
- Community Water System Contingency Plan - required by OEPA for "providing safe drinking water to a water service area under emergency conditions" and prepared by 645th ABW/EME in June 1992.

TABLE 6-2

LIQUIDS FLIGHT
(as of Dec. 1993)

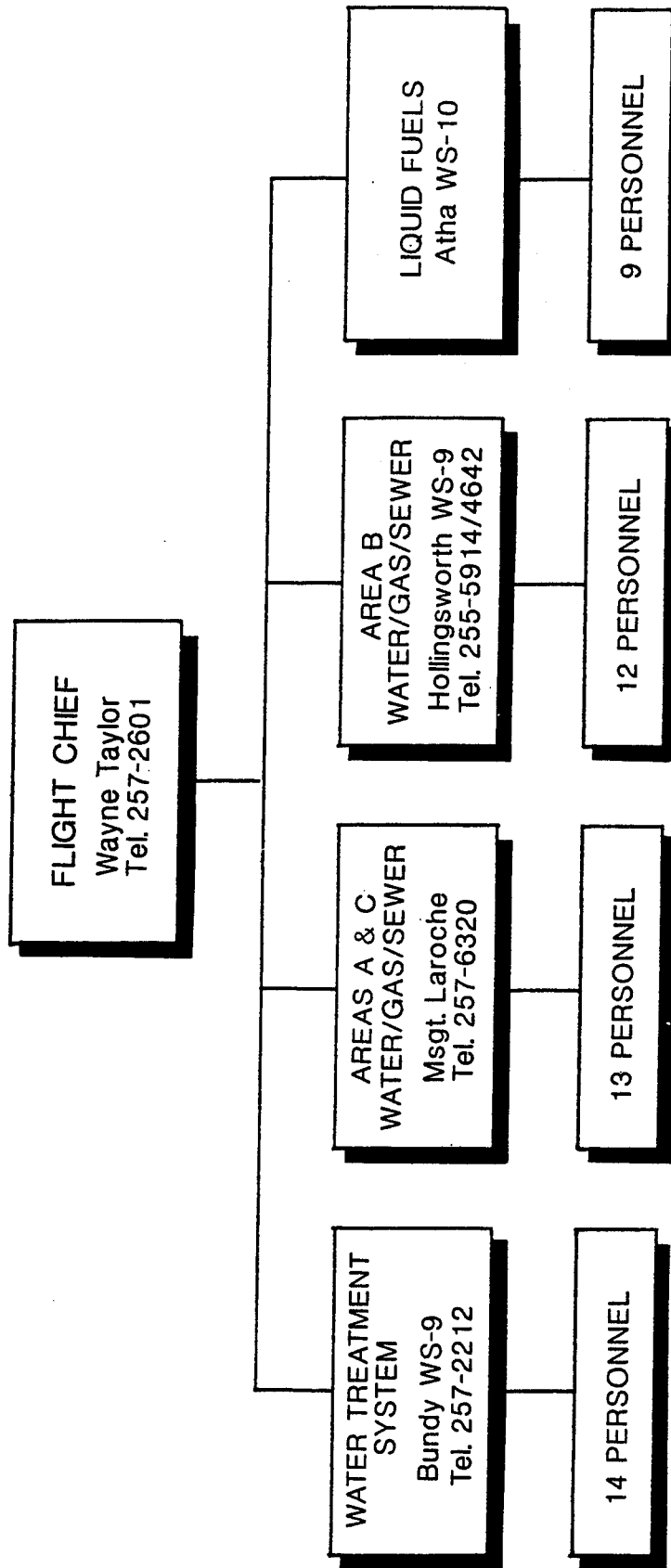

● 29 Civilians ● 23 Military ● 5 Supervisors

- Installation Potable Water System Vulnerability Assessment and Plan - developed and annually updated by Bioenvironmental Engineering Services for water system disaster preparedness and serves as the standardized guide for furnishing surveillance, security, and recovery of WPAFB potable water supply.

VULNERABILITY REDUCTION RECOMMENDATIONS

One of the most obvious deficiencies in the three Area water systems is the lack of emergency power. The existing and recommended emergency generators for each Area are discussed hereinafter.

Monitoring of various water system parameters is essential for rapid emergency response. Recommendations for monitoring the water systems via telemetry are included.

Interconnections with local water systems can be a reliable source of emergency water supply. In particular, larger connections with the Fairborn water system would be beneficial to the Base.

Recommendations are also made for improving various parts of the water distribution systems. Area A and C interconnections, pressure at Woodland Hills, reservoir piping flexibility, and related items are considered.

Emergency Electrical Power. Electrical power outages are associated with most of the disasters that could impact WPAFB. If a disaster strikes the Base when storage reservoirs and elevated tanks are at capacity, short term power interruptions would have minimal effect on water service. However, a power outage occurring when water storage is low or any long term power outage necessitates the use of emergency electrical power sources to maintain water system pressure.

Portable electrical generators available on the Base could be used as a backup to permanently installed generators. However, permanent generators are considered to be the most reliable source of emergency electrical power since they would be dedicated to a specific location and usage.

In regard to their respective water systems, each Area of the Base has different emergency power capabilities. There seems to be no unified approach for furnishing the water facilities with power during outages. Each Area has a need for emergency power at one or more locations in its system. The existing and proposed emergency generators are discussed for each area in the following paragraphs.

Area A - Both Area A wells 8 and 9 have individual emergency generators. Therefore, water could be supplied to the ground level reservoirs #4 and #5 next to the pumphouse, Building 10855. The diesel powered fire pumps can be used to pump water from the reservoirs into the distribution system. No power is available to operate chemical feed pumps, air stripper blowers, lights and controls in the pumphouse, and similar miscellaneous items necessary to provide complete treatment and system operation. It is recommended that an emergency generator be installed next to the pumphouse to provide power for these items and one or more basement sump pumps. The basement of the pumphouse which houses the two electrical and four diesel driven pumps has flooded at least twice in the past. Under these conditions, the distribution pumps cannot be used. It is recommended that a sump be constructed in the basement with two sump pumps installed. Associated with the sump should be a high water alarm indicating that the pumps are not operating or cannot keep up with the volume of flooding.

Area B - Area B wells do not have any standby power and would not be usable during a power outage. Building 20085, the Area B pumphouse, has two emergency generators. A small generator inside the building powers the control panel and lights in the control room. The large generator, located outdoors, powers the fire pumps that feed the low service zone. A diesel operated domestic pump conveys water to the high service zone. In summary, the low zone of Area B will obtain water by gravity from the reservoirs and fire storage Tower #2 and #9, and fire flow pumped the reservoirs. The high zone is dependent on elevated Tower #8 and the diesel operated domestic pump. It is recommended that emergency generators be installed at at least two of the wells in Area B.

Area C - Area C wells do not have any standby power and would not be usable during a power outage. The electric pumps in Building 30172 could not provide any domestic flow. Fire flow to hangars and flight line facilities only would be supplied by the diesel operated fire pumps. A large emergency generator installed on the south side of Building 30172 could supply power to water supply, treatment, and pumping facilities. Included would be the nearby Wells 1 and 2, the air stripper blowers, chemical feed pumps, controls, and at least one of the domestic pumps.

Monitoring. Quick response is essential to reduce the impact of disasters on the water system. Water personnel will be assisted in effecting a quick response by monitoring conditions in the distribution system.

At the present time there is a minimal amount of monitoring information available to the WPAFB water staff. More extensive information could be acquired from a SCADA system or some other telemetry system. A SCADA (supervisory control and data acquisition) system is installed on the Base and currently used for monitoring electrical power consumption. It may be possible to incorporate water system monitoring into the system. Useful parameters that could be monitored include:

- distribution system pressure
- levels in elevated tanks
- flow measurement (interruption)
- fire pump operation
- chlorine residual
- pH
- power failure
- unauthorized access to facilities
- temperature in unmanned facilities, such as wellhouses, to prevent freezing
- other failure mechanisms

Interconnections. Interconnections between the Areas of the Base or with local water purveyors will be highly beneficial when a localized disaster strikes some portion of the facility. For example, if a tornado or bomb devastates the Area C water treatment unit, a hydraulically strong interconnection with Area A and/or Fairborn would help to maintain pressure and fire fighting capability.

An area-wide disaster, such as an ice storm, would disrupt both on and off Base water systems. In this situation, it is unlikely that interconnections could be used to any great advantage.

The Base currently has distribution interconnections between Areas A and C. These interconnections should be analyzed on the KYPIPE computer program developed by Woolpert Consultants^{4,5} to determine adequacy under emergency conditions and potential pipe upgrades.

As discussed in Section 4, there are three existing six-inch connections with Fairborn between Gate 35C and the tank farm in Area C. These connections could supply some domestic demand, but are not capable of supplying fire demand. Since the Fairborn water system now has a 500,000 gallon elevated tank and 24-inch main in this area, the Base could obtain a considerable quantity of City water with a large enough interconnection. The Fairborn elevated tank overflow elevation at 965 equals that at the Area C Tower #7, so the pressures are equal in the Base and Fairborn systems at this location. Fairborn has total capability to provide water during power outages with emergency generators in place at wells, the treatment plant, and pump stations.

In order for this interconnection to be effective, the Area C piping would have to be increased in size. At present only 6 and 8-inch pipes with poor looping are in place in this part of the distribution system. Consideration should also be given to supplying Area A with emergency supply from Fairborn. This could be done by installing a stronger interconnection between Area A and C systems and/or another connection with Fairborn in the vicinity of Gate 15A and Kaufman Road where Fairborn has a 12-inch main and a nearby storage tank.

The Fairborn Water Treatment Plant is located off Sandhill Road within the flight path at the north end of the WPAFB runway. This location is close to the Loop Road around the runway and may offer another potential location for an interconnection between the Area C and Fairborn water systems.

A strong emergency supply from Fairborn could be of particular value to the West Ramp area which no longer has Well E as an additional source for fire flow. It is recommended that an additional water main be extended to the West Ramp along side the Loop Road and tied in to a hydraulically strong connection point in the area of Building 30172. The existing single line to the West Ramp passes beneath the runway overrun and is not readily accessible for repair. In addition, redundancy of service will greatly reduce the vulnerability of the West Ramp which is isolated from the source of its water supply by a considerable distance.

The recommended interconnections with Fairborn are all considered to be short in length and uncomplicated as to their construction. Therefore, these interconnections should be economical to install.

Unfortunately, any interconnections between Area B and the Dayton Water System or Areas A and C involve long lengths of pipeline and other complications. Such interconnections would be very expensive to construct and could not be economically justified for emergency usage only.

In addition to the Fairborn interconnections, there is a known interconnection with Wright State University near Gate 15A. The G-1 Tab¹² indicates an 8-inch pipe from Area A to the University. This line has not been recently used to anyone's knowledge and may be of no value at the present time since booster pumps at Wright State are no longer maintained. The Wright-State water system is too small to provide any substantial emergency supply to Area C.

There is a possibility of interconnecting the existing 8-inch line to a nearby 12-inch line that Fairborn has on the south side of SR444. The Fairborn hydraulic gradient is higher than that in Area A which would benefit the Base.

Woodland Hills. Woodland Hills housing area is known to have low pressure during high demand periods. An emergency that reduces pressure will only exacerbate the condition. Fire suppression in Woodland Hills will be difficult when adequate flow cannot be maintained.

Fairborn has recently installed a water booster pumping station and a high pressure zone distribution main along Zink Road. An interconnection with this high zone main could provide emergency fire flow to Woodland Hills.

The Woodland Hills distribution system should be analyzed to determine the optimal method for providing adequate fire flow under all conditions. The optimal

method may involve the construction of larger distribution mains, looping existing pipes, or a new storage facility. Storage considerations for new building construction in the high zone of Area B should be included in this analysis.

Areas A and C Interconnections. The existing interconnections between Area A and C distribution systems should be analyzed for adequacy under fire flow conditions with one Area serving the other. Tower filling should be included in the analysis since, at present, the tower in one Area overflows at an elevation which prevents filling the other Area tower to capacity.

An interconnection between the Area A and Area C wells would be desirable to provide more flexibility for supply. This could be done by constructing a pipeline between wells 7 and 9 on Skeel Avenue.

Reservoir Piping. The ability to bypass one or more of the ground level reservoirs in all Areas is important if a disaster causes structural damage which makes the unit unusable. An investigation of existing design plans followed by field verification of the existence and operability of valves and diversion devices will determine the need for additional controls.

SUMMARY

The vulnerability analysis of emergency situations has determined a need to correct deficiencies in the Base water systems. The recommended corrective actions to the water systems infrastructure provide a basis for decisions on improving reliability and creating redundancy.

SECTION 7

RECOMMENDATIONS

INTRODUCTION

The previous sections of this report have described the existing Area A, B, and C water systems, considered Base water demands, discussed quality and quantity aspects, and provided a vulnerability analysis. Capital improvements to the water systems infrastructure are recommended in each section, especially in Section 6 which deals with emergency operations. This section summarizes previous recommendations and discusses several issues that involve long term planning for the WPAFB water system.

Selected alternatives will be evaluated in detail in Phase 2. A proposed work plan for detailed hydraulic analyses and economic cost derivations is included as part of Phase 2.

In general, the alternatives may be grouped into these categories:

- Upgrade and improve existing systems for continued operation as separate systems.
- Centralize treatment facilities and improve potable water quality.
- Discontinue treatment on the Base and purchase water from Dayton.

UPGRADE AND IMPROVE EXISTING SYSTEMS

The recommendations to upgrade and improve existing systems are particularly relevant if WPAFB continues its current operations as three separate water systems. However, some of these recommendations are still applicable if the Base commences centralized treatment or decides to discontinue treatment and purchase all water from an off-Base supplier.

Many of these recommendations do not involve large expenditures of funds and should be implementable in a reasonable time frame. This includes most of the considerations for reducing vulnerability. Others, such as the wellhead protection plan, will require inter-municipal agreements and considerable planning or expenditure of monies.

The following recommendations will improve or upgrade existing operations and are listed in order of priority:

- East Wellfield. Select, design, and construct an iron and manganese removal facility at Area B to allow future use of the East Wellfield. Estimate the cost for the chosen treatment process.
- Monitoring. Evaluate parameters that require monitoring including flow measurement. Determine if the SCADA system or a different telemetry system will offer maximum reliability at acceptable cost.
- System Control. Evaluate system controls in each Area as to their adequacy, reliability, and redundancy. Investigate electrical components as part of the system controls evaluation. Determine costs for upgrading.
- Fairborn Interconnection. Investigate optimal emergency interconnections with Fairborn considering economics and hydraulics. Determine by KYPIPE analysis necessary piping improvements on the Base to maximize the hydraulic potential of the interconnections.
- A and C Interconnection. Analyze interconnection between Areas A and C using the KYPIPE computer model of the distribution systems. Develop costs for improved interconnections. Determine the economic feasibility of interconnecting the Area A and C wells versus developing additional wells for Area A or connecting to the East Wellfield.
- Area A Pumphouse. Evaluate alternatives to protect pumps against flooding. This may consist of improving the existing pumphouse by adding a sump with a high water level alarm and replacing deficient pump discharge header piping. Alternatively, investigate the construction of a vertical turbine pump station atop existing reservoirs.
- Well Maintenance. Develop and implement maintenance program to improve the reliability of the water supply wells.
- Emergency Generators. Determine exactly where the generators will be installed based on the discussion in Section 6. Develop a plan to minimize vulnerability by power outages in each Area. Estimate costs to implement the plan.
- Woodland Hills. Using KYPIPE, analyze pressure inadequacies and recommend distribution system improvements. Include the adequacy of elevated storage in the evaluation. Develop costs for upgrading the piping and storage facilities.

- **Storage.** Analyze storage adequacies in all Areas using KYPIPE. Include fire flow requirements as a major consideration for the computer analysis. Recommend additional storage facility locations, sizes, and costs when deemed necessary. Consider altitude valves on the elevated tanks to control overfilling. Select a valve configuration that will provide reliable operation in hard water conditions.
- **Inter-municipal Wellhead Protection Areas.** The prevention of any further aquifer contamination is paramount to assuring a good quality groundwater supply for WPAFB. The topographic and hydrogeological conditions affecting the Base aquifer were discussed in Sections 2 and 4 of this study and in applicable references. The long term protection of the groundwater will involve an inter-municipal agreement between all parties located within the limits of the aquifer. This would include, at a minimum, WPAFB, Fairborn, Green and Montgomery Counties, and the City of Dayton. OEPA would be available to provide guidance and review the inter-municipal wellhead protection plan. The Wellhead Protection Program (WHPP) was established by the 1986 amendments to the SDWA. The WHPP allows states and municipalities to establish programs to protect sole-source aquifers. A major element of the WHPP is determining protection zones around public well supply fields. The USEPA outlines criteria to classify zones of influence and zones of protection. Within each zone, certain land use restrictions are advisable to ensure that contaminated water does not enter the aquifer. Protection zones should extend to desirable locations for future wellfields as well as existing wellfields. An inter-municipal WHPP for Schenectady, N.Y. is discussed in Appendix G. The Schenectady groundwater supply is a buried glacier drift aquifer of similar characteristics to that underlying WPAFB. The municipalities involved in the Schenectady WHPP realize the importance of protecting their drinking water supply and are actively managing the protection of their sole source aquifer. It is recommended that WPAFB take the initiative in promoting a regional WHPP. It is much more desirable to protect a water supply than to allow contamination that necessitates more expensive and more complicated water treatment processes to provide potable water meeting SDWA standards. The recent work by the USGS¹ towards characterizing the aquifer can be the basis for developing an effective inter-municipal WHPP for the WPAFB regional aquifer.
- **Reservoir Piping.** Analyze and field verify valve locations to bypass one or more of the ground level reservoirs in each Area. Recommend any necessary improvements and develop a cost estimate.
- **West Ramp.** Provide an additional water main to the West Ramp to provide redundancy. Analyze undersized piping in the vicinity of Building 30022 to optimize flow to the West Ramp.

CENTRAL WATER TREATMENT PLANT

The planning and construction of a centralized water treatment plant (WTP) is considered to be the highest priority in implementing a Long-Range Water Plan for WPAFB. The decision to furnish all Areas of the Base with softened water could provide the impetus to use one centralized water treatment plant. A Base Task Force⁹ evaluated the advantages and costs for providing softened water to all of Area B. As noted by the task force, AFM 88-10, "Water Supply, Water Treatment," states that softening of the entire water supply for a permanent base may be considered if hardness exceeds 200 mg/l. The water hardness exceeds 300 mg/l for all areas of WPAFB.

Local suppliers, such as Dayton and Fairborn, draw groundwater from the same aquifer and may be expected to have water hardness in the same range as the Base. Fairborn does not soften its water while the Dayton system is provided with lime softened water. The Base is in between Fairborn and Dayton geographically and follows a similar course with its water treatment. Most of the Base does not receive softened water except housing areas and the Kittyhawk Center. As discussed in Section 2, the Base uses several large ion-exchange softeners to reduce the hardness to a target level of 80 mg/l.

If it is decided to commit the large expenditure of funds to soften all of the Base's water, a centralized treatment facility offers many advantages. Due to the iron and manganese in the East Wellfield, an ion-exchange softening process must be preceded by an iron and manganese removal process because of potential fouling of the exchange resin. AFM 88-10 suggests iron and manganese concentrations totaling more than 0.5 mg/l will cause the fouling problems and this value is far exceeded in the East Wellfield.

The lime-soda ash softening process offers the advantages of removing iron and manganese while softening the water. TDS will also be reduced and some organics reduction has been reported. The process can be operated to produce a very consistent hardness level in the finished water. Soda ash is usually used with the lime to reduce noncarbonated hardness. A major disadvantage of this process is the lime sludge produced.

If this process is selected for use, a central plant offers many advantages. Because of the chemical handling requirements, the complexity of operation, and the lime sludge disposal problem a central plant is obviously advantageous.

At least two available locations for a central plant were noted. One of these is in the field adjacent to the reservoirs in Area B and the other is in the southern portion of Area A. In either case, a considerable amount of well collection piping and water distribution piping must be installed.

Water users on the Base would undoubtedly be more satisfied with a lime softened water supply. However, the large costs associated with such a treatment process could not be entirely offset by consolidation of the three existing treatment facilities into one central plant, the elimination of the zeolite softeners for housing and the KittyHawk Center, and the elimination of individual softeners used at some buildings. Using softened water is a major policy decision that requires strong support for the costs of its implementation.

PAGE MANOR

In conjunction with a Base centralized water treatment plant should be a decision to serve Page Manor. If a centralized plant is not chosen for use, the economics of constructing a water main from Area B to Page Manor and treating the water by ion exchange could be compared with the present cost of Dayton water.

PUBLIC SUPPLY

If a policy decision is made to serve all Areas of the Base with softened water, it is imperative to compare the costs of production at a central water treatment facility on the Base against the cost of purchasing water from the City of Dayton. A study would be necessary to determine detailed costs for connection to the City system, the cost for additional distribution mains and storage on WPAFB, and the cost for the purchased water. In this case it would not be necessary to pay a surcharge for purchased water to Greene County since the service main would belong to the City of Dayton. Considerations of water system reliability, drinking water quality, and many other factors would have to be part of any study to purchase Dayton water.

PROPOSED WORK PLAN FOR PHASE 2

Phase 2 of this project, Detailed Alternatives Analysis and Development of a Long-Range Water Plan, will further define and evaluate the alternatives recommended in this report to provide WPAFB with potable water meeting future quantity and quality requirements. The first steps in this effort will be to become familiar with the KYPIPE computer modeling program and use it to evaluate the following scenarios under current and projected demands:

- Potential internal and external interconnections.
- Distribution system upgrades to improve pressure inadequacies and increase redundancy to minimize system vulnerability.
- Storage requirements, particularly for fire flow, to minimize system vulnerability.

The advantages and disadvantages of each selected alternative from this report will be described in detail as well as compared with each other. Recommendations will then be made regarding the most feasible alternatives for the water supply/treatment system and for distribution system improvements. A detailed cost estimate will be developed for each feasible alternative to be used in the comparative analysis and provide the Base with a time-phased prioritized implementation plan. Cost estimates will include elemental breakdowns of capital expenditures (e.g., treatment, upgrades, repairs), life-cycle costs over a 20 year planning period at current interest rates, and savings associated with the alternative over operating the systems as they currently exist.

CONTRACT EFFORT AND TIME SCHEDULE

With the deletion of work contemplated in Phase 1 for cleaning and performing maintenance on a maximum of 27,000 feet of water main, the contract funds appear to be more than adequate for the completion of this project. The proposed efforts will only require a redistribution of these funds from one CLIN item to another. The contract time schedule, which calls for submitting Phase 2 draft and final reports on 12 May 1994 and 16 June 1994, respectively, also appears to be adequate.

LIST OF REFERENCES

1. Hydrogeology, Simulated Groundwater Flow, and Groundwater Quality at Wright-Patterson Air Force Base, USGS, 1993.
2. Management Action Plan, CH₂M-Hill Consultants, September 1993.
3. Records for raw and treatment water quality, WPAFB Bioenvironmental Engineering, February 1993.
4. Water System Inventory, Mapping and Database Development, Area B, Woolpert Consultants, November 1992.
5. Water System Inventory, Mapping and Database Development, Areas A and C, Woolpert Consultants, November 1992.
6. Base Comprehensive Plan, Woolpert Consultants, 1988.
7. Volume 5, Field Investigation Report, IT Corporation, March 1992.
8. Installation Restoration Program Stage 2 Report, Volumes I-IX, Roy F. Weston, 1989.
9. Feasibility Assessment for Water Treatment Plant in Area B, WPAFB Water Treatment Task Force, June 1991.
10. AWWA Manual M-19, Emergency Planning for Water Utility Management, American Water Works Association, 2nd Edition.
11. Water Vulnerability Assessments, Air Force Systems Command, Occupational and Environmental Health Directorate, April 1991.
12. Existing Tab G-1 and hydrant valve/number system, WPAFB

LIST OF ABBREVIATIONS

AFB	Air Force Base
AFR	Air Force Regulation
Areas A, B, and C	The three Areas of WPAFB
Base/WPAFB	Wright Patterson Air Force Base
BAT	best available technology
D/DBP	Disinfection and Disinfection By-Products
ESWTR	Enhanced Surface Water Treatment Rule
GAL or gal	gallons
gpm	gallons per minute
ICR	Information Collection Rule
MCL	Maximum Contaminant Level
MCLG	Maximum Contaminant Level Goals
MG	millions of gallons
MGD	millions of gallons per day (equivalent to 694.4 gpm)
mg/L	chemical concentration in milligrams (mg) of weight per liter (L) of volume (equivalent to parts per million)
$\mu\text{g/L}$	chemical concentration in micrograms (μg) of weight per liter (L) of volume (equivalent to parts per billion)
OEPA	Ohio Environmental Protection Agency
OU	Operable Units
PES	Pacific Environmental Services, Inc.
pCi/L	pico curies per liter
PVC	polyvinyl chloride
SCADA	Supervisory Control and Data Acquisition
SDWA	Safe Drinking Water Act
SOC	synthetic organic chemical
SR	State Route
SWTR	Surface Water Treatment Rule
TDS	total dissolved solids
USAF	United States Air Force
USEPA	United States Environmental Protection Agency
USGS	United States Geological Survey
VOC	Volatile Organic Chemical
WHPP	Wellhead Protection Program
WTP	Water Treatment Plant
645 ABW	645 Air Base Wing

APPENDIX A

MEMO FOR RECORD

SUBJECT: Miami Conservancy District and Floodplain Issues

Miami Conservancy District:

The Miami Conservancy District (MCD) was formed shortly after the 1913 flood in the Miami Valley. Devastated by the flood, residents of the Valley raised \$2,130,000 for the Flood Prevention Fund to design and construct a permanent flood control system. The core of this system was the construction of five dry dams, supplemented by levees and channel improvements. This system was designed to protect against a flood 40 percent greater than the one in 1913, which was a 1000 year flood. Total cost of construction was \$30,860,500 which was raised through bond sales.

The MCD covers portions of a nine county region. It extends only along major waterways and does not cover the entire watershed area (see Attachment 1). Initially there was a great deal of opposition to formation of the MCD and building of the proposed dams. Main reasons for opposition were a fear that dams were inadequate to withhold a substantial flood and the high cost of building and maintaining such an extensive system.

In order to give conservancy districts the required authority for their projects, in 1914 the Ohio legislature passed the Ohio Conservancy Act (also called the Vonderheide Act). A critical aspect of this legislation is that it gave Conservancy Districts a "dominant right of eminent domain" over the rights of eminent domain of cities, utility companies, etc. This prevented cities from using their right of eminent domain to block conservancy district actions. Another important provision of this bill is that it gave conservancy districts the right to issue bonds to fund their projects. Conservancy districts were also empowered to assess landowners for the increase in property values due to flood control and for the preservation of existing property from flood damage. Approximately 30 percent of the MCD income for 1987 and 1988 was generated through assessments.

If the establishment of a conservancy district is desired, a petition must be made to a judge of one of Common Pleas Courts in one of the affected counties. This judge then meets with one common pleas judge from each affected county, and they make a joint determination on the petition. If the judges agree that a conservancy district is required in this area, they approve the petition and establish all practices and procedures for the new conservancy district in accordance with the Ohio Conservancy Act. The Miami Conservancy District, for example, was required to file an annual report to the Common Pleas Court of Montgomery County. The panel of judges remains a standing body, forming the new conservancy district court (see Attachment 2 for the organizational chart of the MCD).

Shortly after its formation, the MCD bought approximately

60,000 acres in the retarding basins of the five earthen dams they planned to construct. The Conservancy then sold most of this land, but placed provisions in the deeds retaining the right to flood the land, to police the property, and to control and prohibit building in the retarding basin. The MCD retained these rights when they passed the deed to Patterson Field over to the Dayton Air Service in 1924. This deed states that MCD retains for itself and its successors forever the right to: 1) "back the waters of the Mad River upon and over the premises hereinbefore described, by the erection and maintenance of a retarding basin called the Huffman Dam, as provided in the Official Plan of said The Miami Conservancy District, with a spillway of the height proposed in said Official Plan being at an elevation of 835.0 feet above sea level." 2) "remove or cause to be removed at the entire cost and expense of the owner, all structures below and elevation of 825.0 feet above sea level."

The Dayton Air Service Incorporated and its successors agreed in the deed: 1) "That no structures shall be erected below an elevation of 830.0 feet above Sea Level, except by written permit of the Board of Directors of said The Miami Conservancy District, first had." 2) "That all structures erected or maintained below the elevation of the Spillway of the Dam, to-wit: 835.0 feet above Sea level, shall be erected and maintained at the risk of the owner." 3) To remove within three (3) months upon receipt of written notice so to do from the Miami Conservancy District, its successors or assigns, all structures below an elevation of 825.0 feet above Sea level."

Obviously WPAFB has not been adhering to the terms and conditions of this deed. I spoke with Mr Don Holtvoigt and Mr Kurt Rinehart of the Miami Conservancy District on 10 Aug 89. Mr Holtvoigt indicated that the base got in the habit of doing what they wanted during WWII when national emergency provisions were enacted. Since that time, the base has not routinely applied for the required permits to construct facilities at 830 feet mean sea level and below. In a 1987 letter to the environmental planning branch (DEEX), the MCD recommended that the base apply for a blanket permit for all existing facilities at 830 feet MSL and below. To date, no action has occurred in response to this recommendation.

Mr Rinehart and I discussed the floodplain elevation at WPAFB. Although the base has been using 810 feet at the 100 year flood plain elevation, a detailed MCD analysis yielded 818.63 feet as the correct elevation (I have a copy of this analysis). Mr Rinehart stated, however, that since the completion of the Buck Creek Reservoir in Springfield, this elevation may actually be too high. The Buck Creek Reservoir controls 12.9 percent of the drainage into the Mad River. Therefore, during a 100 year flood, this reservoir should lower the flood pool by 3.2 feet. Before 815.4 feet MSL could be used, however, a thorough analysis must be completed (Note: The information regarding impact of Buck Creek Reservoir on flood elevation of the Mad River was relayed to Mr

Lance Grolla, DEEP, in a letter from the MCD, dated 27 Mar 86).

Executive Order (EO) 11988:

EO 11988, 24 May 1977, is entitled "Floodplain Management" (see Attachment 3). This EO implements the policies set forth in the National Environmental Policy Act of 1969, the National Flood Insurance Act of 1968, and the Flood Disaster Protection Act of 1973. This EO tasks federal agencies with the responsibility to "minimize the impact of floods on human safety, health and welfare, and to restore and preserve the natural and beneficial values served by flood plains".

EO 11988 discourages federal agencies from construction within a flood plain. If this can not be avoided, federal agencies must take appropriate action to minimize negative impacts to the flood plain. In addition, prior to start of design, they must circulate a public notice explaining why the proposed action will occur within the flood plain. Construction within a flood plain must adhere to standards established by the National Flood Insurance Program and must incorporate flood protection measures in the building design.

AFR 19-9:

AFR 19-9 is entitled Interagency and Intergovernmental Coordination of Land, Facility, and Environmental Plans, Programs, and Projects. Chapter five of this regulation governs floodplain management and implements the provisions of EO 11988. The requirement is levied on the Air Force to notify state and local clearinghouses of proposed construction in the flood plain, and public notification must be made in at least one local newspaper. In determining flood plain location, this regulation states the Air Force should use Water Resources Council guidelines and obtain assistance from the district office of the Corps of Engineers.

U.S. Water Resources Council (WRC) Floodplain Management Guidelines:

In accordance with direction provided in EO 11988, the WRC issued guidelines for flood plain management on 10 Feb 78. These guidelines state that federal agencies should also consider the 500 year flood plain for projects which would be "especially dangerous when exposed to larger floods". In determining locations of the 100 and 500 year flood plain, these guidelines recommend use of a Flood Insurance Rate Map (FIRM) issued by the National Flood Insurance Program.

I talked to Tira Miller of the Natural and Technologic Hazards Division of the Federal Emergency Management Agency (FEMA) (312-408-5546). She informed me that FEMA also uses the FIRM maps in determining flood plain locations. She said I could order these maps from 1-800-333-1363. I should ask for community panel 390193. I spoke with Dave Fort about FIRM maps, and he said I also need

index numbers to order them. He will get index numbers for the base for me so I can order the FIRM maps (the maps are free).

CONNIE L. STROBBE
Environmental Protection Specialist

APPENDIX B



State of Ohio Environmental Protection Agency

Southwest District Office

40 South Main Street
Dayton, Ohio 45402-2086
(513) 285-6357
FAX (513) 285-6249

George V. Voinovich
Governor

July 12, 1991

Re: Wright Patterson Air Force Base
Greene County
Community Water Supplies
Areas A/C - PWS I.D. #2903412
Area B - PWS I.D. #2903312

William Orellana, Colonel, USAF
Commander, 2750 ABW/CC
WPAFB, Ohio 45433-5000

Dear Colonel Orellana:

Section 6109.04 of the Ohio Revised Code requires the Ohio Environmental Protection Agency to perform evaluation surveys of public drinking water supply systems. On May 9, 10, 13, 14, and 29, 1991, I met with the following people to survey the Wright Patterson Air Force Base drinking water supply facilities and discuss their operation: Ms. Sandy Henry, Environmental Protection Specialist, Mr. Wayne Taylor, Distribution System Chief, Ms. Rebecca Wagner, Environmental Engineer, Mr. Guy Fagin, Bio-Environmental Officer, and Mr. C.J. Vehorn, Civil Engineer.

In addition, Stephen Severyn, Drinking Water Unit Supervisor, from our Dayton office, and John Arduini and Iraaj Haghazari, from the Engineering Section of our Columbus office, visited the Base water systems on May 14, 1991.

The following comments pertain to the survey:

1. A review of our records indicates that the water produced by the Areas A/C and B water systems complies with the Ohio EPA drinking water quality standards for bacteriological contaminants. However, it will be necessary to increase the number of total coliform analyses performed each month.
 - a. It was reported that the number of bacteria samples collected was based on Air Force guidelines for water supply systems. However, to avoid being in violation of Section 3745-81-21 of the Ohio Administrative Code, the number of samples collected must be based on the total population served. According to a report submitted by Ms. Henry, the total population served by the Areas A/C water system is 19,287. The population served by the Area B system was reported to be 17,704.

Section 3745-81-21 of the Ohio Administrative Code requires water systems serving populations between 17,201 and 21,500 to have 20 samples collected from the distribution systems and analyzed for total coliform bacteria each month.

In order to comply with Section 3745-81-21 of the Ohio Administrative Code, it will be necessary to begin reporting 20 bacteria samples collected from the distribution systems serving Areas A and C, and 20 samples from the distribution systems serving Area B.

- b. The Areas A/C water system is essentially two separate supply, treatment, and distribution systems which are connected by only two mains. The larger of the two connections is normally valved off. As long as the systems are operated in this manner, the number of samples collected should be based on the populations served by the individual distribution systems. In other words, the distribution systems should be sampled as if they were not connected. This is also true for all other monitoring parameters. If it would be more convenient to report the results from the individual Area A and Area C systems on separate monthly operating reports, feel free to do so.
- c. The bacteria results have been listed in the "less than 5000 population" sections of the monthly operating reports. It will be necessary to begin completing the "greater than 5000 population" section of the forms, where applicable.
- d. Section 3745-81-21(A) of the Ohio Administrative Code states in part:

Public water systems shall collect total coliform samples at sites which are representative of water throughout the distribution system according to a written sample siting plan. Such plans are subject to review and revision by the Director.

It will be necessary to submit a sample siting plan for the Areas A/C and B water systems.

2. As you know, virtually all of the water supply wells serving the Base are contaminated with volatile organic chemicals (VOC's). We have in our files copies of letters from our Columbus office dated June 11 and June 25, 1991, stating that the Base is not in compliance with the VOC monitoring requirements. In order to come into compliance with these requirements, it will be necessary to contact Ms. Tonya Selby in our Columbus office (614-644-2752) to determine what action will be required.

The VOC contamination present in the wells could be from the numerous known landfills and spill sites, or from other unknown contaminant sources on the Base.

- a. Areas B and C supply systems are equipped with packed tower aerators (air strippers). These units were installed without the Ohio EPA plan approval required by Sections 6109.07 of the Ohio Revised Code and 3745-91-02(A) of the Ohio Administrative Code. These units have been granted approval "post construction" by the agency. However, these units were designed for 95% VOC removal instead of the 99% VOC reduction normally required by the Ohio EPA. Plans have been submitted to this agency for two new stripper units to replace the unapproved cooling unit that has been converted into a stripper for the Area A supply system.
- b. It was reported that the strippers serving the Area C system have been out of service since July of 1990, due to a calcium carbonate build up problem that makes prolonged operation of the high service pumps impossible. During the time that the strippers have been out of service, the concrete roof on the finished water storage tank collapsed. It was reported that the strippers will not be returned to service until a solution is found to correct the calcium carbonate build-up problem, and the reservoir roof is replaced.

This leaves the Base with the Area B system operating with two strippers, Area A system operating with one unapproved stripper, and the Area C system operating without the benefit of the two strippers approved for the system.

- c. Without the use of the strippers and the finished water reservoir, the wells in Area C are being individually chlorinated and pumped directly to the distribution system. Analyses from wells #1, 3, and 7 indicate that they are contaminated primarily with tetrachloroethylene and trichloroethylene. The analyses from these wells and well #6 have also indicated the presence of cis-1,2,-dichloroethylene, trans-1,2,-dichloroethylene and 1,1,1-trichloroethane in lower concentrations. Well #2 has been out of service due to a mechanical problem and well #6 is rarely used.

The concentration of tetrachloroethylene in well #1 has been reported as high as 36.5 ug/l in October of 1990, 29.0 ug/l in January of 1991, and at 26.5 ug/l in April of 1991.

- d. Currently there are no enforceable limits for tetrachloroethylene in Ohio. However, the USEPA has established a Maximum Contaminant Level (MCL) of 0.005 mg/l (5 ug/l) and a Maximum Contaminant Level Goal (MCLG) of zero for this contaminant. The USEPA has announced that the effective date for the tetrachloroethylene MCL and MCLG will be July 30, 1992.

- e. Levels of tetrachloroethylene in excess of the forthcoming Maximum Contaminant Level have been consistently reported from the Area C distribution system since the strippers were taken out of service in July of 1990. Tetrachloroethylene was reported in the distribution system at 16.9 ug/l in March of 1991, 15.1 ug/l in April of 1991, and 14.0 ug/l in May of 1991. The highest concentration of Tetrachloroethylene from the Area C distribution system within the last two years has been reported as 25.0 ug/l from a sample collected on June 5, 1990.
- f. Trichloroethylene has been consistently reported between 1.0 and 1.5 ug/l from the Area C distribution system since the strippers were taken out of service. The Maximum Contaminant Level (MCL) for trichloroethylene is 0.005 mg/l (5 ug/l). The Maximum Contaminant Level Goal (MCLG) for trichloroethylene is zero.
- 3. Analyses from wells #8 and 9 in Area A indicate that they are contaminated primarily with trichloroethylene. The analyses indicate that these wells are also contaminated with 1,1,1-trichloroethane and carbon tetrachloride in lower concentrations. The levels of trichloroethylene present in the Area A wells have been consistently reported at levels that range from slightly above to slightly below the Maximum Contaminant Level of 0.005 mg/l (5 ug/l).

The analytical results from the Area A distribution system have reported that the levels of VOC's were below detectable limits from March through May of 1991. However, trichloroethylene was consistently reported in the system between 0.6 and 1.6 ug/l through 1990, and up to February of 1991.

- 4. Analyses from wells #1, 2, 4 and 5 in Area B indicate that they are contaminated primarily with trichloroethylene. The analyses indicate that these wells are also contaminated with tetrachloroethylene, cis-1,2,-dichloroethylene, trans-1,2,-dichloroethylene and 1,1,1-trichloroethane in lower concentrations.
 - a. The levels of trichloroethylene present in the Area B wells have been consistently in excess of the Maximum Contaminant Level. Over the last two years, most of the results from samples collected from the wells have reported trichloroethylene in a range 6 to 8 ug/l. However, some results have been as high as 15 and 21 ug/l.
 - b. The analytical results from the Area B distribution system since the strippers were installed have consistently reported that the levels of VOC's are below detectible limits.

5. In the past, some of the VOC and other analytical report forms for the wells and distribution system have not included the water system Area (A, C, or B), which has created some confusion as to what water system was being addressed. Having some duplicate well numbers has added to this problem. We have numerous results from the Base distribution systems in our files for which the Area is not identified.

Numerous people in our Dayton and Columbus offices monitor these results, which makes explicit labeling necessary. In order to properly identify sample locations, it will be necessary to include the Area (A, C or B) along with the well number or distribution tap location on the sample identification line on the report forms.

6. It has been reported that the lettered wells (A-F) in Area B have not been tested for VOC's, or any other contaminants, since they were taken out of service in 1989. As long as these wells are connected to the water system, and there is the possibility that they could be used, it will be necessary to collect samples from them for VOC analyses and all other applicable parameters. The only alternative to performing the analyses would be to physically sever the line connecting them to the Area B water system.
7. It has been reported that plans are being made to feed a phosphate compound before the Area C strippers and carbon dioxide to the line between the strippers and the finished water reservoir. These measures are being planned in an attempt to reduce the build-up problem in the high service pumps and other equipment. While these measures may help reduce the problem, they may not eliminate the problem entirely.

The addition of carbon dioxide will have to be carefully controlled. Overfeeding carbon dioxide could result in precipitating additional calcium carbonate, making the build-up problem worse.

On May 29, 1991, Mr. Gary Cutler, of our Columbus office, Mr. Charles Taylor, of the Ohio Dept. of Natural Resources, and I visited the Base to inspect the Area C water system and discuss the build-up of calcium carbonate in the high service pumps.

Mr. Charles Taylor has suggested that the 10 inch line between the reservoir and the high service pumps may be restricting the flow of water to the pumps. If this is the case, attempting to draw large quantities of water through a restriction ahead of the pumps could be causing the pumps to cavitate.

Cavitation in the pumps could result in the excessive plating out of calcium carbonate on the impellers. We recommend that the Civil Engineering division investigate the pipe sizing between the strippers and the reservoir.

We must stress the importance of returning the Area C strippers to service as soon as possible to remove the high concentrations of tetrachloroethylene and the trichloroethylene and other VOC's presently in the water being pumped to the distribution system. Tetrachloroethylene and trichloroethylene are suspected carcinogens.

8. It was reported that plans are also being made to begin feeding a phosphate compound to the Areas A and B water systems to sequester hardness and reduce scale formation. It has been noted that plans for the addition of the phosphate feed equipment have been submitted to this agency for review as required.

Where phosphate compounds are fed, samples are required to be collected from the water distribution systems once per month and analyzed in an approved lab for total phosphorus concentrations. These results are required to be entered on the monthly operating reports.

The phosphate feed rate is required to be kept below 10 mg/l and total phosphorus concentration is required to be kept below 1 mg/l in drinking water. It is also required that a concentration of approximately 10 mg/l of chlorine be maintained in the phosphate solution to prevent the growth of bacteria. (Phosphate is a nutrient for bacteria.)

9. We have in our files a copy of a letter from our Columbus office dated December 17, 1990, stating that the Base is not in compliance with the radiological monitoring requirements. In order to come into compliance with these requirements, it will be necessary to contact Ms. Wendy Sheeran in our Columbus office (614-644-2752) to determine what action will be required.
10. The records also indicate that the last inorganic analyses were performed on samples collected from the Area A and the Area C water systems on June 13, 1990. If no other samples have been collected for inorganic analyses since that time, it will be necessary to collect the next samples from the Area A and Area C systems no later than June 13, 1993.

Our records indicate that the last inorganic analyses were performed on samples collected from the Area B water system on June 5, 1990. If no other samples have been collected for inorganic analyses since that time, it will be necessary to collect the next samples no later than June 5, 1993.

Inorganic chemicals are currently required to be performed a minimum of once per three years. However, we recommend that these analyses be performed once per year, and it is expected that this will become a requirement.

- a. The inorganic chemical results reported in 1990 were in compliance with the Ohio EPA Primary drinking water quality standards. However, nitrate was reported at higher than normal levels at 5.48 and 4.22 mg/l in the Area C system and at 3.46 mg/l in the Area A system. The Maximum Contaminant Level for nitrate is 10 mg/l. In order to adequately monitor the elevated levels of nitrate in the water systems, we recommend that analyses for nitrates be performed a minimum of once per year.
- b. The results reported in 1990, for the Area B system, indicated total dissolved solids at 540 mg/l (parts per million), which exceeds the Secondary Maximum Contaminant Level of 500 mg/l.
- c. The lettered wells (A-F) in Area B produce iron in excess of the Secondary Maximum Contaminant Level (SMCL) of 0.3 mg/l. It has been reported that these wells have not been used for approximately two years.

Section 3745-91-09 requires treatment for iron removal be initiated if major changes are made to the source or treatment of water. Air strippers were installed since the last time the wells were used and are considered major changes to the treatment. This being the case, it would be necessary to add iron removal equipment before using these wells again. This would be a major project involving preparation of plans, submittal of the plans to this office for approval, and construction of a plant or equipment capable of removing iron.

11. Our records indicate that samples were collected for synthetic organic chemicals (SOC's) analyses from the Area B water system on June 6, 1990, and on June 13, 1990, for the Area A and Area C water systems. The results reported comply with the Ohio EPA drinking water quality standards. Samples for synthetic organic chemicals must be submitted a minimum of once per year. If you have any questions regarding these analyses, please contact Mr. James Evans of our Columbus office (614-644-2752).

12. Section 3745-7-02(A) of the Ohio Administrative Code requires public water supplies serving populations of 10,000 or greater to perform total trihalomethane analyses from the distribution system each calendar quarter. Since the populations served by the Areas A/C and B systems exceed 10,000, it will be necessary to ensure that these analyses are reported to our Columbus office. If you have any questions regarding these analyses, please contact Mr. Ron Smith (614-644-2752).
13. Section 6109.04(B)(1) of the Ohio Revised Code states that every owner of a public water system shall have analyses of the water made at such intervals and in such a manner as may be ordered by the Environmental Protection Agency. Records of the results of such analyses shall be maintained and reported as required by the Agency.
 - a. Instructions for the drinking water operation report form supplement Fluoride Adjustment (EPA form 5011) directs public water systems to enter the certification number of the lab performing the fluoride tests. No lab certification number has been entered on the monthly operating report for the Area B system. It was also reported that the lab certification number entered on the Areas A/C water system report form may not be correct.
 - b. Also, it has been noted that the samples collected for fluoride analyses from the distribution system in Area B have been reported in the "Plant Tap" column of the monthly operating reports. This was discussed during the survey and I was assured that these results would be reported in the "Distribution" column in the future.
 - c. It is also required that the raw water be analyzed for fluoride a minimum of once per month and the results entered on the monthly operating reports. These results have not been reported consistently.
 - d. The instruction form also directs public water systems that lose their capability to feed supplemental fluoride to notify the Ohio EPA within 48 hours and provide a tentative schedule for the resumption of supplemental fluoridation. This Agency has not been notified of interruptions in the fluoride feed in the past.
14. As the fluoride feed systems get older and eventually need to be replaced, we recommend that they be replaced with direct feed 25% hydrofluosilicic acid systems. Our experience with direct acid feed systems is that they are much easier to operate and maintain, and provide a more consistent feed rate. The potential for employees breathing hazardous sodium fluoride dust would also be eliminated.

15. It has been noted that no hardness tests are being performed on samples from the Area A/C water system. Hardness tests are performed on samples from the Area B system with an unapproved and inaccurate test kit. These results have not been reported in the past, and would not satisfy the requirements if they were reported.

Public drinking water supply systems that soften water are required to have a minimum of one hardness test per day performed by an Ohio EPA approved lab, and report the results on the monthly operating reports. Since Area C has two softening plants, hardness results are required from both plants and from the Area B softening plant.

In order to report these results, it will be necessary to submit additional monthly operating reports and/or make some modifications to the forms. However, the modifications made should be kept to a minimum where possible, and the information should be clearly labeled.

16. It was reported that softening plant 1229 (Kittyhawk) in Area C is operated to produce water with zero hardness. Softening water to zero hardness is not recommended for drinking due to suspected detrimental health effects and also due to the fact that water with zero hardness is corrosive. Corrosive water could damage water mains and plumbing, and cause lead and copper contamination in the drinking water. New requirements regarding lead and copper in drinking water may eventually prohibit operating drinking water softening plants in this manner.

One option that could be considered would be to supply the housing units and other potable service connections served by this plant from another water system. Another possibility would be to by-pass water around the 1229 softening plant to the housing units and other potable connections.

17. Public water systems with ion-exchange softening plants are also required to have samples collected from the distribution systems once per month for chloride analysis. Since there are three major ion-exchange softening plants at the Base, it will be necessary to report chloride results from each of the distribution systems served by the plants. These results are required to be entered on the monthly operating report forms.

18. Rule 3745-81-28 of the Ohio Administrative Code requires that hardness, chloride, and the other operational control analyses be performed by an Ohio EPA approved laboratory. The laboratory at WPAFB has not been approved by the Ohio EPA to perform hardness and chloride analyses.

If lab approval is desired, it will be necessary to contact Mr. James Evans of our Columbus office (614-644-2752) to arrange a lab survey. If Ohio EPA lab certification for these parameters is not pursued, it will be necessary to send samples to an approved lab to perform the analyses. Please include a time-frame in the response to this letter for having these analyses performed and reported.

19. We recommend that alkalinity stability tests be performed once per week to determine if the water produced by the ion-exchange softening plants is excessively corrosive. Results of these analyses could be entered on the monthly operating reports.
20. General comments regarding the monthly operating reports are as follows:
- a. The distribution systems served by the three softening plants and the three distribution systems that deliver unsoftened water must be checked daily for free and total chlorine and the results reported on the monthly operating reports. The lowest values for chlorine should be reported, not averaged.
 - b. The total water production for the Area B water system should be reported on the monthly operating reports, as well as the softened water produced.
 - c. In order to help keep our color coded filing system in order, we ask that the monthly operating reports supplied by this office be used (yellow, green and blue forms), or similar forms on appropriately colored paper.
 - d. Hand written entries on the monthly report forms must be legible. Typed or computer printed entries are preferred.
 - e. It will be necessary to include the correct Water Supply Operators certificate numbers on the monthly operating reports.
 - f. It will also be necessary to include all of the various certificate numbers of the labs performing the individual analyses reported on the monthly operating reports.

21. Water Supply Operators licenses are required to be displayed at the treatment plants. The licenses were not available during the survey.

It was noted that the lab certification certificates are displayed in the Base's water lab as required.

22. Section 6109.04(B)(1) of the Ohio Revised Code directs the Ohio EPA to govern public water systems to protect the public health. Section 6109.04(C)(2) of the Ohio Revised Code directs the Ohio EPA to provide a program for the general supervision of operation and maintenance of public water systems.

- a. In the past, Base personnel have failed to report significant developments affecting the water systems to our office. We have become aware of significant changes in the operation of the water systems such as by-passing treatment for VOC's in Area C and discontinuing softening and fluoridation in Area B while the softening plant was being rebuilt. Changes such as these should be reported to this office. Major equipment failures such as the collapse of the Area C finished water storage reservoir roof should also be reported.

In the future, it will be necessary for Base personnel to keep us informed of all significant changes in drinking water system operation. We request that this agency be notified of changes in treatment before they occur and major equipment failures as they occur.

- b. The Air Force has also failed to obtain plan approval on numerous occasions in the past before making modifications to the water supply systems. Plans are required to be submitted and approved by this agency before making significant changes in the water supply and treatment systems, or constructing additional equipment. Section 3745-91-02(A) of the Ohio Administrative Code states in part:

No person shall begin construction or installation of a public water system, or make a substantial change in a public water system, until plans therefor have been approved by the Director of Environmental Protection. An application for approval of plans for such construction, installation, or substantial change in a public water system, as required by Section 6109.07 of the Revised Code, shall be submitted to the district office.

Plan approval is also required before constructing water main extensions. Mr. James Garties, P.E., or Mr. Mike Joseph of this office, should be contacted for information regarding the submission of plans for approval at (513) 285-6357.

It should be noted that the Ohio EPA requires well site acceptance before new wells can be developed. Should information regarding well site acceptance be needed, please contact me.

- c. The Ohio EPA also requires the owners and operators of public water systems to report all analytical contaminant results from the drinking water systems to our district office, even if the contaminant monitoring is not required by the Ohio Administrative Code. Results from such analyses from WPAFB have not been reported in the past.
23. After the finished water reservoir roof is replaced, before returning it to service, it will be necessary to disinfect the reservoir as described in the American Water Works Association (AWWA) Standard D104. After disinfecting the reservoir, it will be necessary to have two consecutive negative bacteria results reported from samples collected from the reservoir before returning it to service. The bacteria samples are required to be collected twenty-four hours apart. Section 3745-83-02(G) of the Ohio Administrative Code requires that these practices be followed whenever work is performed inside finished water storage tanks. (These analyses should be designated as "special purpose samples" and should not be entered on the monthly operating report forms.)
24. The Ohio EPA has begun issuing classification certificates to public drinking water systems serving populations of 250 or more. As part of this survey, the water supply facilities at WPAFB have been evaluated for supply and distribution system classifications.

The facilities for Area A/C were determined to be a Class II water supply and Class II distribution system. The facilities for Area B were also determined to be a Class II water supply and Class II distribution system. The supplies and distribution systems had previously been classified as Class I systems. The Air Force will be receiving classification certificates and certified operator information from our Columbus office in the near future.

25. During the survey, it was noted that five of the Base's wells (#8 and 9 in Area A, #3 in Area C, and #4 and 5 in Area B) are located in pits or building basements with the well casings terminating below ground level.

Section 3745-9-09(E) of the Ohio Administrative Code requires well casings that terminate below ground level to be extended to a minimum of eight inches above ground level. Recently adopted Rule 3745-81-76 of the Ohio Administrative Code requires this agency to evaluate public water supply wells to determine the potential for their contamination by surface water. Among the criteria to review is whether there are any deficiencies in well construction. Wells in pits or basements with the casing terminating below ground level are considered to be improperly constructed.

Improperly constructed wells will be designated as producing "groundwater susceptible to the influence of surface water", and if left uncorrected, will be required to be treated as surface water.

26. Section 3745-81-76 of the Ohio Administrative Code requires wells to be evaluated to determine if they could be susceptible to contamination with surface water. Section 3745-81-76(2)(a) of the Ohio Administrative Code requires wells to meet all of the requirements for new wells which are stated in Rules 3745-9-04 to 3745-9-07 of the Administrative Code. In addition, wells that are not protected to an elevation of 3 feet above the 100 year flood level are considered to be improperly constructed and will require treatment as surface water.
- a. It appears that all of the wells supplying Area A and C, and the lettered wells (A-F) in Area B, have casings that terminate below the 100 year flood elevation. If this is not correct, or if any of these wells are 3 feet above the 100 year flood elevation, please submit evidence to this effect at this time. All of the wells that are to remain as supplies of the drinking water systems must be modified to be protected from flooding to at least 3 feet above the 100 year flood elevation, if not so protected at this time.
- b. It was also noted that none of the Base's wells were equipped with a downturned and screened vent as required. Where flooding is a possibility, the vents must extend 3 feet above the 100 year flood elevation.

- c. Where casings terminate below the 100 year flood elevation, wells with submersible pumps, securely sealed casings, and vents of acceptable design which extend 3 feet above the 100 year flood level, are acceptable. We have been instructed to not accept turbine pumps in pits or basements as ground water sources because the shaft seals are not capable of preventing the entrance of water into the well.
- d. Improperly constructed wells and wells not flood protected to 3 feet above the 100 year flood level will be designated as producing "groundwater susceptible to the influence of surface water", and if left uncorrected, will be required to be treated as surface water. Surface water is subject to more complex and costly treatment (coagulation and filtration) along with increased operational and monitoring requirements.
- e. If the lettered wells (A-F) in Area B are to be kept as stand-by supplies, it will also be necessary to have them modified to be flood protected. The only alternative to flood protecting these wells would be to physically sever the line connecting them to the Area B water system. If the line is severed, it must not be reconnected without approval from this office.
- f. Section 3745-81-73 of the Administrative Code requires community water supplies to provide filtration within eighteen months of having wells designated as surface water, or ground water susceptible to the influence of surface water. We began evaluating the wells for designation as part of this survey.
- g. As part of the evaluations, we are requiring public water supplies with wells close to surface water or other contaminant sources to have their individual wells sampled before treatment for bacteria once per calendar quarter for a minimum of one year. It appears that well #6 is the only well close to a surface water source (approximately 100 feet from Hebble Creek). However, it was reported that a gravity sewer is approximately 50 feet from wells #1 and 2 in Area B.

At a minimum, it will be necessary to perform quarterly bacteria analyses on wells #1 and 2 in Area B. Ms. Henry stated that quarterly bacteria analyses would be performed on all of the drinking water wells presently in use. If analyses are performed on all of the wells, it will be necessary to mark the submission forms as "raw water", and submit all of the results to this office.

- h. It would probably be less difficult and less expensive to upgrade the wells by extending the casings above ground than to construct and operate a surface water treatment plant. It appears that the most practical course of action would be to install pitless adapters (where applicable), extend the casings above ground level, seal the wells against flooding, and install vents above the flood elevation at this time. (See the Recommended Standards For Water Works for well construction guidelines.)
27. The Ohio EPA is planning to implement a new program to require water purveyors to enforce wellhead protection measures to eliminate possible sources of contamination near their water supply wells. Such measures include adopting zoning ordinances, or other such administrative requirements, to prohibit land use practices which could contaminate drinking water wells.

In order to protect the wells and aquifer from additional contamination, it will be necessary to ensure that no contaminants are stored within a well's zone of contribution or zone of influence. At a minimum, no contaminants should be allowed within 300 feet of any drinking water supply well.

Base personnel should begin taking a survey of the land use practices around the well fields and evaluating the hazards which they may present to the wells. Capture zones for the wells should be defined in terms of one and five years travel time to the wells.

- a. It was noted that a diesel fuel tank is located in building 172, approximately 35 feet from well #2 and approximately 100 feet from well #1 in Area C. Another diesel tank located at building 851 is approximately 10 to 15 feet from well #8 and approximately 400 feet from well #9.

In order to properly protect wells #8 and 9 from a diesel fuel spill, it will be necessary to provide a secondary containment basin under the diesel tank at building 851. Building 172 should be evaluated to determine if it could contain a spill from the diesel fuel tank.

- b. It was reported that a gravity sewer is located approximately 50 feet from wells #1 and 2 for Area B.
- c. It was also noted that well #6 is located approximately 100 feet from Hebble Creek and wells #8 and 9 and are located within 300 feet of Hebble Creek. Large amounts of contaminants spilled to Hebble Creek may have contributed to, and could increase, the contamination of these wells.

- d. It was also reported that a tank farm was once located across the street from wells 1, 2, and 3 in Area C.
 - e. As for the numerous landfills and spill sites; in the future, the Air Force may want to consider installing interceptor wells between the drinking water wells and the contaminant sources, in addition to remedial action.
28. We are aware that there are numerous wells that once supplied the water systems but are no longer in use as drinking water supply wells. It has been reported that some of these wells have been converted to supply water to non-potable water systems. Other wells are no longer connected to the drinking water systems but could be put back into operation to obtain additional water for the potable or non-potable systems.

If there is a possibility that some of these wells will be put back into use in the future, and they are properly maintained, then they will not have to be properly abandoned. However, Section 3745-9-10(B) of the Ohio Administrative Code states:

If a well containing walls is not being used for obtaining ground water or for determining the quality, quantity, or level of ground water, such well shall either be completely filled with grout or such other material as will prevent contaminants from entering ground water, or maintained in strict compliance with all applicable requirements of Regulation 3745-9-09.

At a minimum, it appears that the well at building 86D in Area B and the well that supplied water to the farm house that was torn down on the north-east edge of the Base will have to be abandoned. Other wells that may need to be abandoned are the lettered wells (A-F in Area B) and well #4 in Area C. (Please note that any well not properly abandoned remains subject to Section 3745-9 of the Ohio Administrative Code.)

29. It was noted that two electrical boxes in the basement of building 203 (well #3) have corroded away leaving the cables exposed. This equipment and the electrical equipment for the other wells should be evaluated and replaced where unsafe conditions exist.
30. It was noted that the ion-exchange softening plant at building 85A has been in the process of being rebuilt. The piping, controls, brine tank and the ion-exchange media have been replaced. We consider this maintenance since the facility has been rebuilt as originally designed without being expanded. This being the case, plan approval was not needed.

It was reported that plans are being made to increase the capacity of softening plant 857. The expansion of this plant will require the submittal of detailed plans to this office for approval. It will be necessary to receive Ohio EPA plan approval before beginning construction.

31. Of the ground level finished water reservoir vents that were checked, none were protected with screen in the openings. Section 7.0.9 of the Recommended Standards For Water Works (Ten State Standards) states:

Finished water storage structures shall be vented. Overflows shall not be considered as vents. Open construction between the sidewall and roof is not permissible. Vents

- a. shall prevent the entrance of surface water and rain water.
 - b. shall exclude birds and animals.
 - c. should exclude insects and dust, as much of this function can be made compatible with effective venting. For elevated tanks and standpipes, four-mesh noncorrodible screen may be used;
 - d. shall, on ground-level structures, terminate in an inverted U construction with the opening 24 to 36 inches above the roof or sod and covered with twenty-four mesh noncorrodible screen installed within the pipe at a location least susceptible to vandalism.
32. Of the six elevated tanks connected to the potable water systems, two tanks are normally valved off for use as fire protection in Area B. It was reported that the tanks are partially drained and refilled once per month in order to maintain a chlorine residual. It was also reported that an attempt is being made to make the tanks operate continuously as part of the system, to eliminate this problem. However, we will continue to be concerned about the bacteriological quality of the water in these tanks until they are continuously valved on to the system. If the tanks are separated from the distribution system, the chlorine in the stored water will dissipate and leave the water susceptible to contamination.

It will be necessary to drain, or partially drain, and refill the tanks as often as necessary to maintain potable water quality in the tanks. This will be necessary until the valves separating the tanks from the distribution system can be opened and the tanks are operated continuously as part of the distribution system.

It will also be necessary to perform bacteria and chlorine analyses at frequencies that are adequate to demonstrate that the water in the fire tanks is of satisfactory drinking quality. Performing bacteria analyses once per week is recommended. Regarding chlorination, Section 3745-83-02(B) of the Ohio Administrative Code states in part:

Unless exempted under the provisions of this Rule, each community water system and each major non-community water system shall maintain a minimum chlorine residual of at least two-tenths milligram per liter free chlorine, or one milligram per liter combined chlorine measured at representative points throughout the distribution system.

33. It was noted that the overflow discharge pipe on the SAC elevated tank is connected directly to a storm sewer. It was also noted that the large elevated fire tank in Area B does not have an overflow pipe that extends down to ground level. Section 7.0.6 of the Recommended Standards For Water Works states:

All water storage structures shall be provided with an overflow which is brought down to an elevation between 12 and 24 inches above the ground surface, and discharge over a drainage inlet structure or a splash plate. No overflow may be connected directly to a sewer or a storm drain. All overflow pipes shall be located so that any discharge is visible.

Part b. of this section also states:

The overflow of a ground-level structure shall open downward and be screened with twenty-four mesh noncorrodible screen installed within the pipe at a location least susceptible to damage by vandalism.

In order to conform to the Recommended Standards, it will be necessary to sever the connection between the overflow pipe and the storm sewer on the SAC elevated tank, and have the overflow on the fire tank brought down to ground level. The overflows should discharge above a storm sewer or a splash plate as stated in the Recommended Standards For Water Works.

34. It was reported that the elevated storage tank serving Area C will probably be replaced with a larger tank. It will be necessary to have detailed plans for this project approved by this agency before beginning construction.
35. The Ohio EPA and the Recommended Standards For Water Works agree that large public water systems should maintain an average day's use of water in elevated storage. Our calculations indicate that there is only approximately 13% of an average day's usage in the Area B elevated tank used exclusively for the potable system. Our calculations also indicate that there is approximately only 31% of an average day's usage in the Areas A/C elevated tanks.

If the elevated fire storage tanks were normally operated as part of the Area B potable system, the total amount of potable water available in elevated storage would be approximately 56% of an average day's use.

Failing to maintain a day's supply of water in elevated storage could severely affect the Base's ability to function normally in the event of a power failure, if alternative power is not available. The Air Force may want to consider providing more elevated water storage tanks in addition to the new tank planned for Area C.

36. During the survey, we discussed the need for protecting the water system from backflows of contaminants through industrial and commercial service connections. The backflow prevention program at the Base appears to exceed the Ohio EPA requirements. However, we must point out that the following are required:
 - a. Section 3745-95-04(A) of the Ohio Administrative Code states:

An approved backflow prevention device shall be installed on each service line to a consumer's water system serving premises, where in the judgement of the supplier of water or the director, a health, pollutional, or system hazard to the public water system exists.
 - b. Section 3745-95-04(C) of the Ohio Administrative Code requires backflow prevention devices to be installed on service lines to hospitals, mortuaries, clinics, nursing homes, laboratories, sewage treatment plants, sewage pumping stations, storm water pumping stations, food and beverage processing plants, chemical plants, metal plating industries, petroleum processing or storage plants, radioactive material processing plants or nuclear reactors and car washes.

- c. Section 3745-95-03(A) of the Ohio Administrative Code requires the suppliers of water to conduct surveys of other potentially hazardous service connections to the water system to determine if backflow prevention devices are required on any other service lines. It is also required that Ohio EPA approved backflow prevention devices be properly installed on all service lines that require the devices.

Mr. Taylor reported that the devices are tested regularly and that an inventory of devices in service and potentially hazardous service connections is maintained on a computer.

37. The people that operate and maintain the water systems at WPAFB deserve to be congratulated. They appear to be doing a good job of keeping the systems operational. This could be no easy task considering how the systems are constructed. Unfortunately, the water systems were not designed back in the 1930's and 1940's to serve an area as large or a population so great as they currently serve. The water systems apparently started small and were enlarged, pipe by pipe and well by well, until the systems became a haphazard collection of randomly placed supplies and treatment facilities. This makes the proper treatment, operation and maintenance of the systems extremely difficult.

It has been necessary to install strippers in three locations instead of one. Also, three large ion-exchange plants are in operation along with approximately 50 smaller softening units, yet much of the water delivered is not softened. Fluoride is also added at two locations and chlorine is added at three or more locations.

It is safe to assume that the Base will continue to proliferate indefinitely. Considering this, we believe that it is essential that a long range plan for improving and upgrading the water systems be pursued. We also believe that serious consideration should be given to constructing a centralized VOC removal and lime softening water treatment plant that is capable of supplying all areas of the Base, or purchasing water from another public water system. The Air Force may want to consider planning for such endeavors in the Ten Year Water System Improvements Plan.

We realize that constructing a plant or converting to purchased water would take years to plan and complete. However, some of the benefits realized would probably include: higher quality water, more reliable service, elimination of numerous small softening plants and softeners in buildings, and reduction of maintenance.

Colonel William Orellana, Commander
July 12, 1991
Page 21

The cost of maintaining and operating one treatment plant instead of three or more should be more cost efficient. Also, much of the existing treatment and supply equipment could be moved and used in the construction of a centralized treatment plant. With the exception of adding feeder mains to the new plant, few changes in the distribution systems would be required.

The Air Force may want to consider trying to find an uncontaminated portion of the aquifer in which to develop new wells, and should also investigate the possibility of adding more connections to other water systems. We believe it would be wise to investigate alternate water sources in order to be prepared to supply the Base with water should the levels of contamination in the existing wells rise to the point where treatment would be unable to remove it to acceptable levels. Additional connections to other systems could also be beneficial in the event of treatment system breakdowns, equipment being taken out of service for maintenance, or prolonged power failures.

We appreciate the cooperation we have encountered while conducting this survey. If you believe any misunderstandings have occurred regarding any of the items listed, please bring them to my attention.

Please respond in writing by September 9, 1991, to let us know what action the Air Force plans to take regarding these matters. If you have any questions, feel free to call me at (513) 285-6357.

Sincerely,



Rex Brown
Public Drinking Water Unit

cc: Terry Black, Director of Environmental Management, 2750 ABW/EM
Sandy Henry, Environmental Protection Specialist, 2750 ABW/EME
Major Thomas, Commander, Civil Engineering Squadron, 2750 CES/CC
Ch. Msgt. Anderson, Chief, Structures Branch, 2750 CES/DEMB
Wayne Taylor, Distribution System Chief, 2750 ABW/DEMBW
C.J. Vehorn, Civil Engineer, 2750 ENG/DEEESC
Guy Fagin, Bio-Environmental Officer, Medical Center/SGB
Wm. P. McCullough, M.S.P.H., Greene County Health Commissioner
Donald R. Schregardus, Director, Ohio EPA, Columbus
OEPA, DPDW, Kenneth Applegate, Ph.D, Water Quality Section, CO
OEPA, DPDW, Engineering & Operations, Columbus

APPENDIX C



DEPARTMENT OF THE AIR FORCE
HEADQUARTERS 2750TH AIR BASE WING (AFLC)
WRIGHT-PATTERSON AIR FORCE BASE, OHIO 45433-5000

REPLY TO
ATTN OF:

EM

12 2 JAN 1992

SUBJECT:

Ohio EPA Sanitary Survey of Community and Non-community Public Water Supplies,
PWS IDs #2903312, 2903412, 2955012, and 2955712 (Your ltrs 12 & 17 Jul 91)

TO:

Ohio Environmental Protection Agency
Southwest District Office
ATTN: Mr Rex Brown
40 South Main St
Dayton OH 45402-2086

1. Attached to this letter are detailed responses (Atchs 1-2) to the comments made in your sanitary survey letters of 12 and 17 Jul 91. In order to make these documents most effective for future reference, the comments have been topically arranged with parenthetical reference to the comment numbers in your letters.

2. The following general comments apply to each of our water supplies and will not be repeated in the attachments:

a. Operations and laboratory data reports filed on Ohio EPA color-coded forms will be completed in accordance with directions on the forms and will not be modified except as agreed to with you for soft water production in Areas B and C. Operator and laboratory certificate numbers will be accurately shown (your comments 1c, 13a/b, and 20 of 12 Jul 91).

b. The various reporting offices at this facility as well as our contract laboratory have been advised of the correct public water supply names and identification numbers and the information to be included in sample identifications. These items should be consistent in all future reports (your comments 5 of 12 Jul 91, and 4a/b of 17 Jul 91).

c. Whenever system failures or outages occur (with the exception of a fluoride feed outage) that are expected to last for 48 hours or more you will be promptly notified of the situation, expected duration and corrective action being taken. In the case of a fluoride feed failure that is expected to last more than one day, you will be notified of the situation, expected duration and corrective action being taken as soon as possible but not later than 48 hours after the failure occurred (your comments 13d and 22a of 12 Jul 91).

d. Significant changes or additions to the water supply, treatment, and distribution systems will not be constructed without prior approval from Ohio EPA (your comments 2a, 22b, 30, and 34 of 12 Jul 91).



COMBAT STRENGTH THROUGH LOGISTICS

e. All certified laboratory analytical data on drinking water samples will be reported to Ohio EPA without regard to whether the sampling and analysis is required by regulation (your comment 22c of 12 Jul 91).

f. Operator licenses, water system classification certificates, and the water laboratory certification will be displayed as required (your comment 21 of 12 Jul 91).

3. Bacteriological sampling plans for both community water supplies are included as attachment 3.

4. Should you have any questions concerning any of the items discussed in this letter or attachments, please contact Ms Becky Wagner or Ms Sandy Henry of this office at 257-5535.

ANTHONY F. SCULIMBRENE, Director
Office of Environmental Management

3 Atchs:

1. Response on Non-Comm PWS
2. Response on Comm PWS
3. Bacteriological Sampling Plan

cc: 2750 ABW/CA/JAE
2750 ENSG/DE/DEMIU/DEEESC
Med Cen/SGB

RESPONSE TO MAY 1991 SANITARY SURVEY BY OHIO EPA
NON-COMMUNITY PUBLIC WATER SUPPLIES
WPAFB Marksmanship Facility, PWS I.D. #2955012
WPAFB Boy Scout Camp, PWS I.D. #2955712

Note: Parenthetical numbers refer to paragraphs in Ohio EPA's 17 Jul 91 letter

Sampling and Analysis

1. Bacteriological samples will be collected quarterly from both wells and the results submitted to Ohio EPA on individual laboratory report sheets. Sampling at the Boy Scout Camp was begun in August 1991. (1a/b/c)
2. Nitrate samples will be collected at least triennially from both wells. The next sample from the Marksmanship Facility will be collected not later than 6 Apr 92. The first sample from the Boy Scout Camp was collected in August 1991. (1a,3,6)
3. Volatile organic analyses will continue to be performed quarterly on samples from the Marksmanship Facility well. (2)
4. In accordance with the identification of the Boy Scout Camp well as a public water supply, a one time analysis of the well water for inorganic, synthetic organic, volatile organic and radiological parameters was performed in August 1991. (5)
5. All records pertaining to the americium incident which occurred several years ago near the Scout Camp were confiscated by the Nuclear Regulatory Commission and no copies remain in our files. The base radiation safety officer, Mr Mark Mays, 2750 ABW/EMB, has advised that no radioactivity was found at the ground surface at the Boy Scout Camp and that tests of the well water were, therefore, not warranted. However, an interoffice memorandum from Dec 87 indicates that samples from the Boy Scout Camp were tested for various parameters including radioactivity and that the radiological results were all negative. (7)

Well Construction & Flood Protection

1. According to our records, both of these wells lie within the 100-yr flood plain of the Mad River. (8a)
2. A project has been initiated to upgrade all in-service water wells to meet current well construction standards, be sealed against surface water intrusion and be vented at least 3 ft above the 100-yr flood elevation. We expect to have this work designed in FY92 and constructed in FY93. (8b/c/d/e)

Attachment 1

Contingency Plans

1. The level of volatile organic chemical (VOC) contamination at the Marksmanship Facility has remained relatively constant over the past two years and continues to be below maximum contaminant levels (MCL). Considering the transient nature of the small population served and also the fact that the well supplies a workplace rather than residences, no plans have been made to install a treatment system. In the event that any VOC should exceed an MCL, bottled water would be provided for drinking until a treatment system could be installed. (2)

RESPONSE TO MAY 1991 SANITARY SURVEY BY OHIO EPA
COMMUNITY PUBLIC WATER SUPPLIES
WPAFB Area A/C, PWS I.D. #2903412
WPAFB Area B, PWS I.D. #2903312

Note: Parenthetical numbers refer to paragraphs in Ohio EPA's 12 Jul 91 letter

Sampling and Analysis

1. A minimum of 20 coliform samples will be collected from each of the Areas A/C and Area B distribution systems monthly. Within the Areas A/C system the 20 samples will be proportioned according to the population served within the A distribution system and the C distribution system. A sample siting plan is being submitted concurrently with this document. (1a/b/d)
2. Quarterly VOC sampling of wells in the Area B East Wellfield (Wells A-C, E, and F) resumed in the fourth quarter (Oct-Dec) of 1991. (2)
3. Ohio EPA approvals of polyphosphate feed equipment for Areas B and C and the air stripper system for Area A have been received. Installation of equipment should begin soon. Once the polyphosphate systems are on line we will adjust the feed rates to insure that they do not exceed 10 mg/l and that the total phosphorus level in distribution does not exceed 1 mg/l. Samples will be collected at least once per month from each phosphate supplemented distribution system and analyzed by a certified lab for total phosphorus. Also, operators will be required to maintain an approximately 10 mg/l chlorine level in the polyphosphate stock solution to prevent bacterial growth. (8)
4. Inorganic, radiological, synthetic organic, and semi-volatile organic analyses were performed on samples collected in Jun 91 from the distribution systems in Areas A, B, and C. These analyses are being performed annually in an effort to identify trends and provide the best possible water to the base. Nitrate results, ranging from 2.0 to 3.8 mg/l in the most recent sampling, are well below the 10 mg/l maximum contaminant level. Although total dissolved solids (TDS) is approximately at the secondary maximum contaminant level of 500 mg/l, soft water is provided to residences. Any further treatment to reduce TDS and hardness will be considered in the long range planning currently in progress. (10,11)
5. Pursuant to the sanitary survey we received 13 Aug 91 letters from Mr Ron Smith of Ohio EPA directing us to begin trihalomethane analyses in the Sep-Nov quarter of this year. Sample locations have been identified and include at least one location in each distribution system representing the maximum residence time of water in the pipes. Initial samples were taken in Nov 1991. (12)
6. Operators have been instructed to collect raw water samples a minimum of once per month for fluoride analysis. These results will be included on the monthly operating reports. (13c)

7. Daily analyses for hardness and monthly analyses for chloride will need to be performed on each of the three soft water distribution systems (two in Area C and one in Area B). Samples collected for chloride tests will be sent off base to an Ohio EPA approved laboratory to be analyzed. This office has been in communication with Mr Jim Evans of Ohio EPA and Mr Jim Dolfi of Ohio Dept of Health regarding certification of the water laboratory here at WPAFB to perform hardness tests. We are currently in the process of procuring laboratory equipment, reagents and related supplies, however, we have been advised by the supplier to expect delays in obtaining all of the required items. We anticipate, therefore, that we will not be able to obtain the required laboratory certification until early 1992. In accordance with this schedule, reporting of these parameters on monthly operating reports is expected to begin no sooner than May 92. (15,17,18)

8. In order to more fully evaluate the recommendation that alkalinity stability tests be performed on soft water, we request that Ohio EPA supply a written analytical method, or a reference for same, along with criteria for evaluating test results. (19)

9. In accordance with OAC 3745-81-76 (B)(2)(b) we have begun quarterly bacteriological analyses on raw water from all active wells. First and second quarter samples were collected in Jul and Oct 91 and all results were negative. These results are being forwarded to Ohio EPA, SW District Office, as "special purpose, raw water" samples. (26g)

10. Ohio EPA recommendations for assuring that the Area B elevated fire supply tanks maintain a potable supply of adequately chlorinated water have been reviewed and the following actions taken. The tower water was initially sampled daily and now is sampled at least weekly for residual chlorine. Chlorine levels have been consistently above 0.2 mg/l. The fire supply tanks are being drained and refilled weekly. As long as residual chlorine is adequate, bacteriological samples will be taken once per quarter. In the event that residual chlorine falls below 0.2 mg/l, a bacteriological sample will be collected and, if bacteria are present, the tower will be chlorinated. This procedure will be followed until a communications line can be installed to provide control of the towers from the Area B water plant at Bldg 85A (WPAFB Work Request #74268). After that time, the towers will be drained and filled as needed to maintain a fresh, chlorinated water supply (but not less than once per week). The system will also be studied to determine whether the tower controls can be automated to provide a continuous turnover of water. (32)

Well Construction & Flood Protection

1. Five wells were identified in the survey as being located in pits or basements and consequently having well casings terminating below ground level. We have initiated a project to upgrade all active wells to meet Ohio EPA well construction standards including extending well casings to a minimum of 8 inches above ground level. This work is expected to be designed in FY92 and accomplished in FY93. (25,26b)

2. WPAFB concurs that wells #7, #8, and #9 serving Areas A and C and the East Wellfield serving Area B (Wells A-C, E, and F) are within, or less than 3 feet above, the 100 year flood plain. However, wells #1, #2, and #3 in Area C, at

ground elevations between 821 and 823 feet, will have casings terminating at least 3 feet above the 100 year flood elevation once these wells are upgraded to current well construction standards. The 100 year flood elevation for this area which lies behind Huffman Dam was given by the Miami Conservancy District as being 818.63 feet. Similarly, wells in the Area B West Wellfield along Springfield Street (wells #1, #2, #4, and #5), at ground elevations between 789 and 792 feet, will have casings terminating at least 3 feet above the 100 year flood elevation once the wells are upgraded to current well construction standards. The Miami Conservancy District identified the 100 year flood elevation on the Mad River at the Montgomery-Greene County line as 787.0 feet and downstream at the Harshman Road bridge as 771.0 feet. Area B wells #1-#5 extend west along Springfield Street (or downstream in reference to the river) from the county line. Ground elevations at the wells are based on aerial photography mapping with 1 foot contours and are shown on the enclosed maps. (26a)

3. Wells not cased to at least 3 feet above the 100 year flood elevation will need to be protected against intrusion of flood waters by securely sealing casings, replacement of turbine pumps with submersibles (where applicable), and installing downturned and screened vents which extend to an elevation of at least 3 feet above the 100 year flood elevation. It is our intention to meet Ohio EPA well construction standards in order to insure designation of the source as groundwater. A project to upgrade these wells has been initiated and we expect to have this project designed in FY92 and constructed in FY93. (26b-f/h)

Abandoned Wells

1. Wells #4 and #6 in Areas A/C were physically disconnected from the water system with an air gap (by removing a section of pipe) in Jul 91 and will be properly abandoned in accordance with Ohio EPA rules (WPAFB Work Request #80096). (26g,27c,28)

2. As noted in the sanitary survey, there are abandoned wells in the vicinity of active Area B wells along Springfield St. These wells are currently being evaluated for their potential to be placed back into operation (WPAFB Work Request #81510). Those wells which are too shallow, too small diameter, or otherwise not adequate for reuse will be properly abandoned in accordance with Ohio EPA rules. Old, abandoned wells in other locations, where wells can be positively located, will also be included in that project for well closure (WPAFB Work Request #80096). In addition, WPAFB will continue to research records to identify abandoned wells for future closure. (28)

Inactive Wells

1. It was recommended that the wells in the Area B East Well Field (wells A-C, E, and F) be physically disconnected from the water system because the wells have not been in service for two years and the raw water is not being tested as required by Ohio EPA regulations. After an initial decision to physically disconnect the wells, an alternative that will allow raw water sampling was devised. A valve has been installed in the 24" line between the well field and the Area B water plant and the valve will be kept closed. Adjacent to the

valve, on the well field side, a hydrant has been installed through which raw water can be wasted when the well pumps are operated for system testing and sample collection. Ohio EPA Southwest District Office personnel have confirmed that the valve and hydrant can be installed without submitting plans for review. Sampling of these wells resumed in the fourth quarter (Oct-Dec 91). (6,26e)

2. Projects have been initiated to design and install an iron removal system for the Area B East Well Field (WPAFB Work Request #81113) and to upgrade the East Wells, including sealing casings, replacing pumps, and venting wells three feet above the 100-year flood elevations (WPAFB Work Request #81116). These are major undertakings which will require several years to design, fund and construct. At the present time Wright-Patterson is developing a long range plan for water supply and treatment including a capital improvements plan. The requirements for iron removal treatment and well upgrades will be addressed in that plan. Therefore, it is expected that the well upgrades addressed by the plan would be designed in FY93 and constructed in FY94. It is also expected that an iron removal system addressed by the plan would be designed and constructed in approximately the same time frame. It is our intention to meet Ohio EPA well construction standards in order to insure designation of the source as groundwater. At the present time the East Well Field (wells A-C, E, and F) is expected to remain inactive. (10c, 26e, 37)

Air Stripper Treatment Systems

1. The plans for installation of carbon dioxide and polyphosphate injection systems for control of scaling in the Area B and C air strippers have been approved by Ohio EPA and a construction contract has been awarded. Also, the failed reservoir roof in Area C has been removed and a construction contract to install an aluminum roof dome has been awarded. Once these projects are completed the Area C towers will be placed back in service. This should occur in the spring of 92, before the new tetrachloroethylene standard becomes effective in Jul 92. (2b-f)

2. WPAFB's civil engineering design office (2750 ENSG/DEEE) has investigated the possibility of cavitation as a cause of scale formation in the Area C system. It was determined that (1) from pump manufacturer data, NPSHR = 10 ft, and (2) from flow calculations, NPSHA = 19 ft. Therefore, cavitation does not appear to be a problem. Also, the amount of scale upstream of the pumps suggests that the pumps are not significantly contributing to the problem of scale formation. (7)

3. The plans submitted to Ohio EPA by WPAFB for two new stripper units for the Area A supply have been approved. That construction should be completed in 1992. (2a)

Water Storage Facilities

1. A new roof should be in place on the Area C finished water reservoir by Apr 92. After the new roof is in place, the reservoir will be disinfected in

accordance with American Water Works Assn Standard D104. To demonstrate that adequate disinfection has been performed, two consecutive days of negative bacterial samples are required before the reservoir is returned to service. Reservoir disinfection and bacteriological testing will be coordinated with the startup of the air stripper system so that the reservoir is not allowed to stand idle after disinfection. The bacterial analyses will be reported as "special purpose samples" on the monthly report forms. (2b,23)

2. All vents on ground level finished water reservoirs have been examined for the presence and condition of screens. New screens have been installed, as needed, on the Area A reservoirs. A project has been initiated to install screens, as needed, on vents at Area B reservoirs (WPAFB Work Request #75960). A new vent and screen will be installed on the Area C reservoir when the new roof is installed. (31)

3. It was recommended that an average day's use of water be maintained in elevated storage in each system to insure adequate capacity in the event of a power outage. However, standby power arrangements are present at wells 8 and 9 in Area A, Bldg 855 in Area A, and Bldg 85A in Area B. With this standby power and with the interconnections between the Area A and Area C distribution systems, the current systems meet the Air Force and industry standards for water storage/supply. When repairs/modifications to the water storage/supply systems are made WPAFB will review the possibilities of upgrading the system to exceed industry standards. (35)

4. Two specific defects in overflows from elevated tanks were identified in the sanitary survey, specifically, direct connection of the SAC (West Ramp) tower overflow to a storm sewer and the overflow from the large Area B fire tower not extending to ground level. Projects have been initiated (WPAFB Work Requests #80845 & #81508) to correct these defects. (33)

System Classifications

1. Following the sanitary survey, WPAFB received 16 Aug 91 letters from Ohio EPA's Division of Public Drinking Water confirming the upgrade of our community water supplies to Class II. In accordance with that letter we responded with operator certification information on 29 Oct 91. (24)

Wellhead Protection

1. WPAFB's Office of Environmental Management is in early stages of developing a wellhead protection program and is reviewing the proposed Ohio EPA wellhead protection program requirements. The U.S. Geological Survey has been contracted to develop time of travel zones around base wells using local and regional groundwater models. No surveying of facilities around wells has been performed to date. (27)

2. Projects to provide secondary containment for diesel fuel tanks at Bldg 172, the Area C pumphouse, and Bldg 851, wellhouse for well #8, have been initiated (WPAFB Work Request #80876). (27a)

3. A 15-inch, vitrified clay, gravity, sanitary main passes 50 feet from Area B wells #1 and #2. Quarterly bacteriological analyses of wells are currently being performed. Samples from Jul and Oct 91 from wells #1 and #2 were negative for coliform bacteria. This main is a major line which carries wastewater collected from approximately one-third of Area B. However, if this line were to become suspect of contaminating the Area B water wells, corrective action would be taken. Potential actions to remediate such a problem would include slip lining the pipe, replacing the pipe with water main type piping, or relocating the main to provide additional isolation distance. (26g, 27b)

4. Wells #8 and #9 serving Area A are located 85 feet from the centerline of Hebble Creek. Hebble Creek flows through underground culverts from its entry onto WPAFB from Fairborn to a point 1400 feet upstream of well #9 where the creek resurfaces. From that point Hebble Creek is routed through concrete lined channel for 1400 feet until it reaches well #9 and resumes natural channel. Well #8 is located 480 feet further downstream. However, the concrete channel provides some protection against migration of contaminants through the creekbed in the vicinity of well #9. (27c)

5. An underground tank farm is located across the street from the Area C water plant, in relatively close proximity to wells #1, #2, and #3. These underground tanks have never been used to store chlorinated solvents and are not believed to be the source of the volatile organic contamination present in the Area C wells. Of the 16 tanks in the farm only four are currently in use. WPAFB is in the process of locating alternate storage facilities for the materials now stored at the tank farm with the intention that within three years all tanks will have been removed, the farm closed, and the site remediated. (27d)

6. The only contaminants seen in base wells are relatively low and stable levels of volatile organic chemicals. In addition, no concentrated plumes of contaminants have been identified as well contaminant sources. Therefore, at this time interceptor wells would not provide an effective means of wellhead protection. WPAFB will continue to investigate known and potential sources of contamination as well as options available for effective control of any contaminants identified. (27e)

Unresolved OEPA Notices of Violation

1. On 26 Jul 91 WPAFB published a notice in the base newspaper advising our water users of the fact that certain inactive wells had not been monitored for volatile organic chemicals during the quarters Oct-Dec 90, Jan-Mar 91, and Apr-Jun 91. A copy of this public notice was transmitted to Ms Tonya Selby at Ohio EPA on 1 Aug 91 in order to clear the violations issued 9 May 91 (and addressed in OEPA correspondence dated 11 Jun and 25 Jun 91). As stated previously, sampling of those wells which were not abandoned resumed in the fourth quarter (Oct-Dec 91). (2)

2. The 1 Nov 90 notice of violation issued by Ohio EPA for missing Area B radiological data concerns initial quarterly sampling performed at this facility in 1978. Maintenance of records in excess of 10 years is not required by either Air Force or Ohio EPA regulations. However, WPAFB was able to locate copies of quarterly radiological data from 1978 and these were transmitted to

Ms Wendy Sheeran of Ohio EPA on 14 Feb 91. In addition, repeat quarterly sampling was begun in Jun 91. (9)

Other Recommendations

1. The current fluoridation systems which use sodium fluoride are not expected to need replacement for many years. When new systems are needed, WPAFB design engineers will review all types of systems available, including your recommendation for direct feed 25% hydrofluosilicic acid units. (14)
2. The water softening plant at Fac 1229 (Kittyhawk) is operated to produce water with zero hardness. This is a requirement of the heating plant which is the major user of the soft water produced by this plant. This plant also supplies water to barracks (dormitories), Visiting Airmen's Quarters, mess hall, transient quarters, bowling alley, recreation center, NCO club, and credit union, but does not supply family housing. Consequently, it is not the only source of drinking water for its customers. For these reasons, there are no plans to by-pass or blend water to provide partially softened water to facilities at Kittyhawk. (16)
3. A project has been initiated to repair electrical equipment at Bldg 203, Well #3, Area C (WPAFB Work Request #80841). (29)
4. The WPAFB plumbing shops are primarily responsible for maintaining backflow prevention equipment and identifying additional facilities or systems which are in need of backflow prevention. Additionally, all facility projects are reviewed by various base agencies to insure that potential backflow contamination sources are identified and appropriate protection installed. (36)

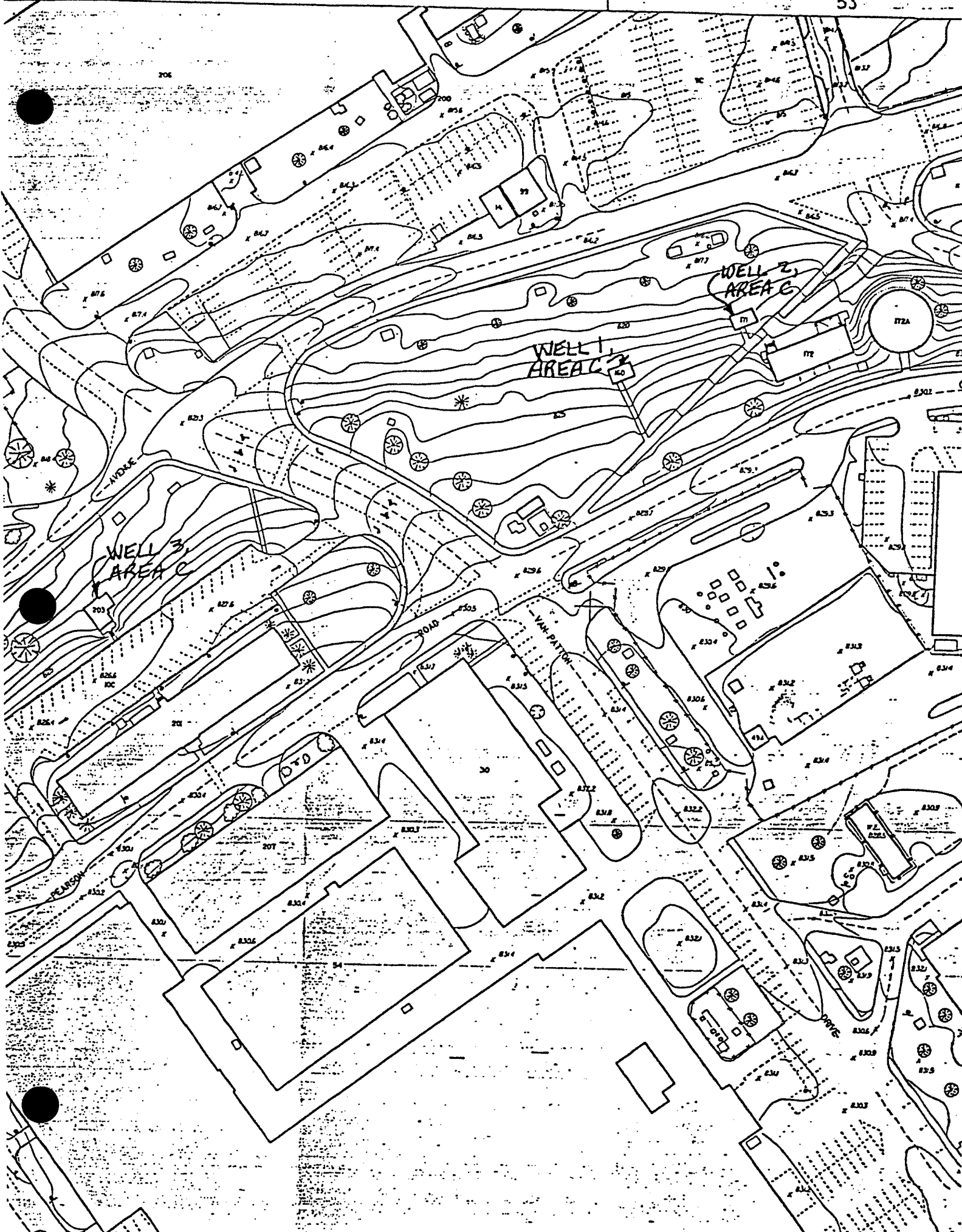

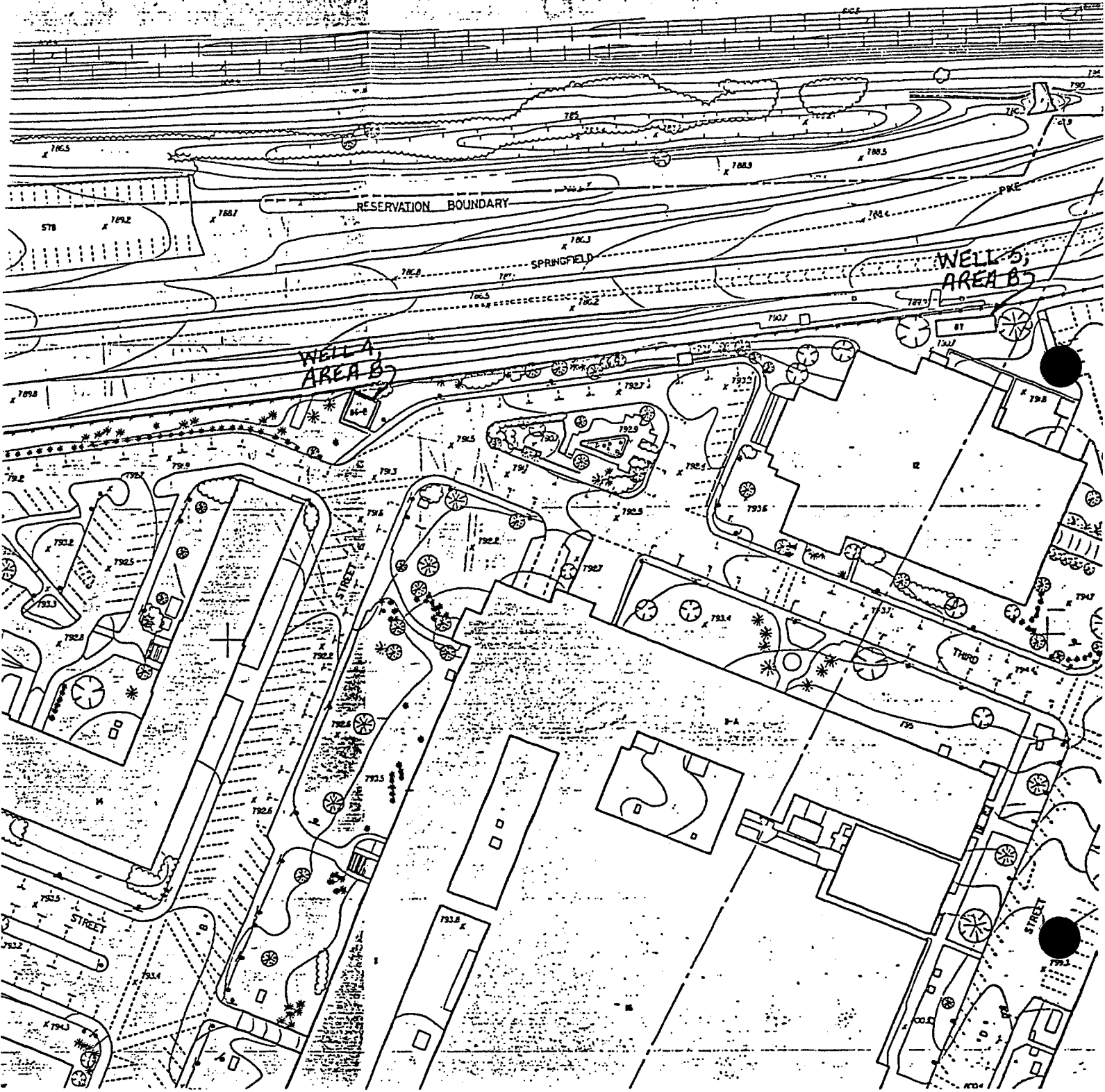

BACTERIOLOGICAL SAMPLING PLAN
Wright-Patterson Air Force Base

Community Public Water Supply #2903412, WPAFB Areas A/C

10 Sites, each sampled twice per month:

<u>Area A</u>	<u>Area C</u>
Bldg 10266	500 Housing (family housing)
Bldg 10280	Brick Quarters (family housing)
Bldg 10876	Bldg 30001
Bldg 11455	Bldg 30022
	Bldg 31214
	Bldg 34012

Community Public Water Supply #2903312, WPAFB Area B

10 Sites, each sampled twice per month, plus one site sampled as noted:

Woodland Hills (family housing)	Bldg 20127
Bldg 20008	Bldg 20489
Bldg 20011	Bldg 20620
Bldg 20028	Bldg 20624
Bldg 20045	Bldg 20641
Twin Lakes Family Camp (sampled once per month in season)	

Notes on Community Water Supply Sampling:

1. See attached maps for locations of buildings and housing areas.
2. This sampling plan has been in effect since September 1991.
3. WPAFB intends to install dedicated sample stations plumbed into water mains outside, but adjacent to, the above facilities (except Twin Lakes Family Camp). Presently samples are collected from taps within the buildings.

Non-Community Public Water Supplies

WPAFB Marksmanship Facility, PWS ID#2955012: Sampled quarterly

WPAFB Boy Scout Camp, PWS ID#2955712: Sampled quarterly in season (Apr-Oct)

Note: -- The Scout Camp well is disabled and drained over winter because it is not freeze protected.

Other Sampling

The Page Manor family housing area, supplied by Montgomery County, is sampled monthly.

BASEWIDE WEEKLY WATER MAP
SUBDIVIDED INTO
AREAS

KEY:

WEEK 1 & 3 -

WEEK 2 & 4 -

5 Atch ;
AREA A (2)
AREA B
AREA C
W.R. & KH.

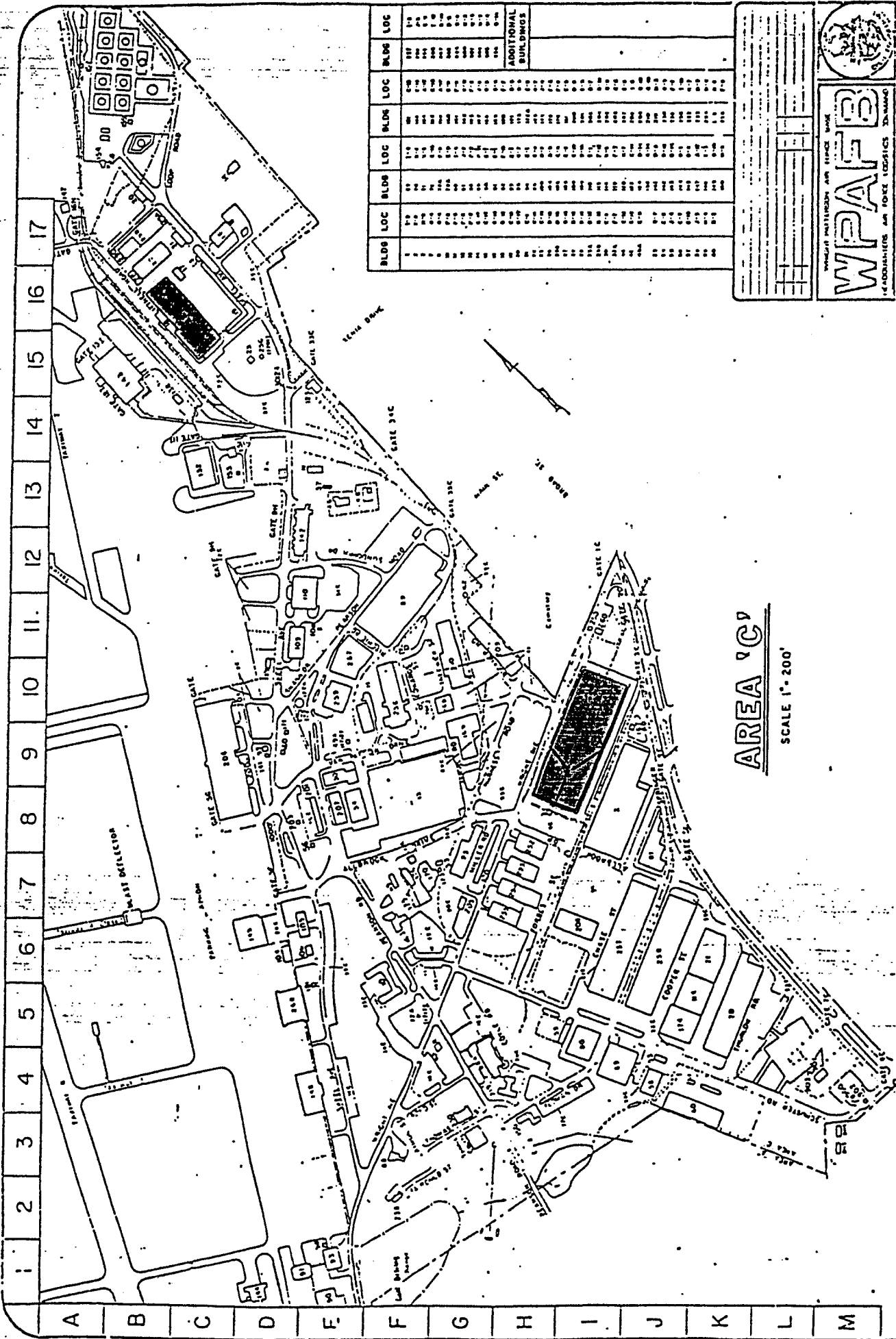

AREA 'C'
SCALE 1" = 200'

BLDG	LOC	BLDG	LOC	BLDG	LOC	BLDG	LOC	ADDITIONAL BUILDINGS
101	101	102	102	103	103	104	104	
105	105	106	106	107	107	108	108	
109	109	110	110	111	111	112	112	
113	113	114	114	115	115	116	116	
117	117	118	118	119	119	120	120	
121	121	122	122	123	123	124	124	
125	125	126	126	127	127	128	128	
129	129	130	130	131	131	132	132	
133	133	134	134	135	135	136	136	
137	137	138	138	139	139	140	140	
141	141	142	142	143	143	144	144	
145	145	146	146	147	147	148	148	
149	149	150	150	151	151	152	152	
153	153	154	154	155	155	156	156	
157	157	158	158	159	159	160	160	
161	161	162	162	163	163	164	164	
165	165	166	166	167	167	168	168	
169	169	170	170	171	171	172	172	
173	173	174	174	175	175	176	176	
177	177	178	178	179	179	180	180	
181	181	182	182	183	183	184	184	
185	185	186	186	187	187	188	188	
189	189	190	190	191	191	192	192	
193	193	194	194	195	195	196	196	
197	197	198	198	199	199	200	200	

WPAFB

 1st AIR FORCE

AREA 'C'

 BLDG. LOCATIONS

4-5

1 2 3 4 5 6 7 8 9 10 11 12 13 14 15 16 17 18 19

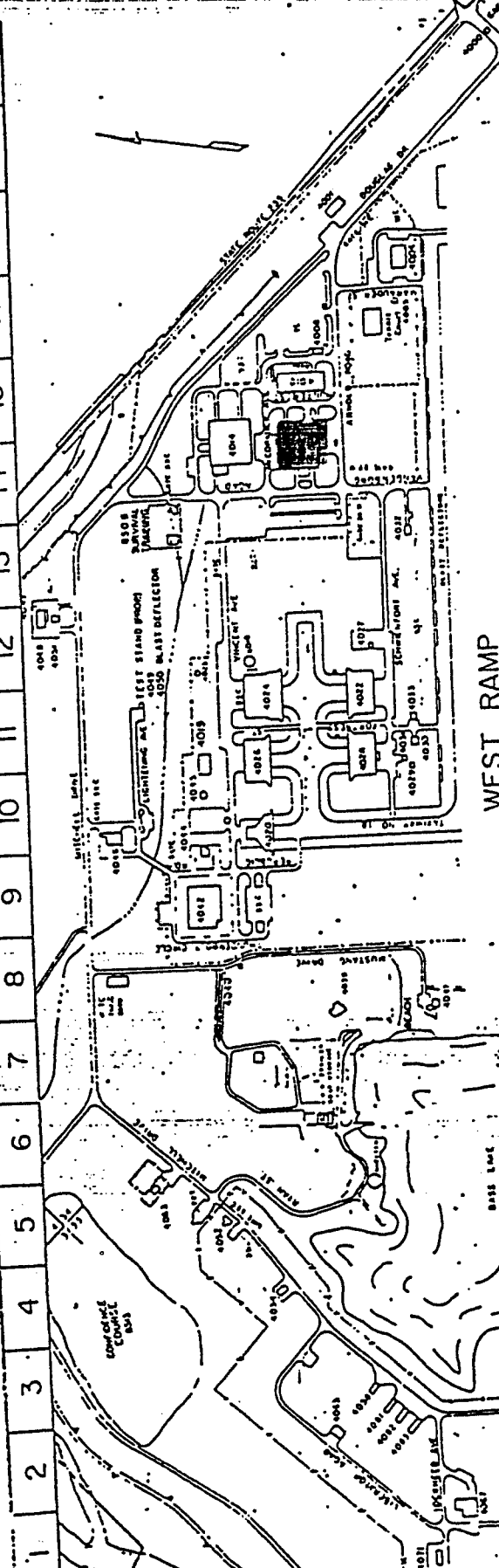

WEST RAMP
SCALE 1" = 100'

BLDG	LOC	BLDG	LOC	BLDG	LOC
1001	1001	1002	1002	1003	1003
1004	1004	1005	1005	1006	1006
1007	1007	1008	1008	1009	1009
1010	1010	1011	1011	1012	1012
1013	1013	1014	1014	1015	1015
1016	1016	1017	1017	1018	1018
1019	1019	1020	1020	1021	1021
1022	1022	1023	1023	1024	1024
1025	1025	1026	1026	1027	1027
1028	1028	1029	1029	1030	1030
1031	1031	1032	1032	1033	1033
1034	1034	1035	1035	1036	1036
1037	1037	1038	1038	1039	1039
1040	1040	1041	1041	1042	1042
1043	1043	1044	1044	1045	1045
1046	1046	1047	1047	1048	1048
1049	1049	1050	1050	1051	1051
1052	1052	1053	1053	1054	1054
1055	1055	1056	1056	1057	1057
1058	1058	1059	1059	1060	1060
1061	1061	1062	1062	1063	1063
1064	1064	1065	1065	1066	1066
1067	1067	1068	1068	1069	1069
1070	1070	1071	1071	1072	1072
1073	1073	1074	1074	1075	1075
1076	1076	1077	1077	1078	1078
1079	1079	1080	1080	1081	1081
1082	1082	1083	1083	1084	1084
1085	1085	1086	1086	1087	1087
1088	1088	1089	1089	1090	1090
1091	1091	1092	1092	1093	1093
1094	1094	1095	1095	1096	1096
1097	1097	1098	1098	1099	1099
1100	1100	1101	1101	1102	1102
1103	1103	1104	1104	1105	1105
1106	1106	1107	1107	1108	1108
1109	1109	1110	1110	1111	1111
1112	1112	1113	1113	1114	1114
1115	1115	1116	1116	1117	1117
1118	1118	1119	1119	1120	1120
1121	1121	1122	1122	1123	1123
1124	1124	1125	1125	1126	1126
1127	1127	1128	1128	1129	1129
1130	1130	1131	1131	1132	1132
1133	1133	1134	1134	1135	1135
1136	1136	1137	1137	1138	1138
1139	1139	1140	1140	1141	1141
1142	1142	1143	1143	1144	1144
1145	1145	1146	1146	1147	1147
1148	1148	1149	1149	1150	1150
1151	1151	1152	1152	1153	1153
1154	1154	1155	1155	1156	1156
1157	1157	1158	1158	1159	1159
1160	1160	1161	1161	1162	1162
1163	1163	1164	1164	1165	1165
1166	1166	1167	1167	1168	1168
1169	1169	1170	1170	1171	1171
1172	1172	1173	1173	1174	1174
1175	1175	1176	1176	1177	1177
1178	1178	1179	1179	1180	1180
1181	1181	1182	1182	1183	1183
1184	1184	1185	1185	1186	1186
1187	1187	1188	1188	1189	1189
1190	1190	1191	1191	1192	1192
1193	1193	1194	1194	1195	1195
1196	1196	1197	1197	1198	1198
1199	1199	1200	1200	1201	1201
1202	1202	1203	1203	1204	1204
1205	1205	1206	1206	1207	1207
1208	1208	1209	1209	1210	1210
1211	1211	1212	1212	1213	1213
1214	1214	1215	1215	1216	1216
1217	1217	1218	1218	1219	1219
1220	1220	1221	1221	1222	1222
1223	1223	1224	1224	1225	1225
1226	1226	1227	1227	1228	1228
1229	1229	1230	1230	1231	1231
1232	1232	1233	1233	1234	1234
1235	1235	1236	1236	1237	1237
1238	1238	1239	1239	1240	1240
1241	1241	1242	1242	1243	1243
1244	1244	1245	1245	1246	1246
1247	1247	1248	1248	1249	1249
1250	1250	1251	1251	1252	1252
1253	1253	1254	1254	1255	1255
1256	1256	1257	1257	1258	1258
1259	1259	1260	1260	1261	1261
1262	1262	1263	1263	1264	1264
1265	1265	1266	1266	1267	1267
1268	1268	1269	1269	1270	1270
1271	1271	1272	1272	1273	1273
1274	1274	1275	1275	1276	1276
1277	1277	1278	1278	1279	1279
1280	1280	1281	1281	1282	1282
1283	1283	1284	1284	1285	1285
1286	1286	1287	1287	1288	1288
1289	1289	1290	1290	1291	1291
1292	1292	1293	1293	1294	1294
1295	1295	1296	1296	1297	1297
1298	1298	1299	1299	1300	1300

WEST RAMP & KITTYHAWK BLDG. LOCATIONS

WPAPFB

WEST RAMP & KITTYHAWK BLDG. LOCATIONS

SCALE 1" = 100'

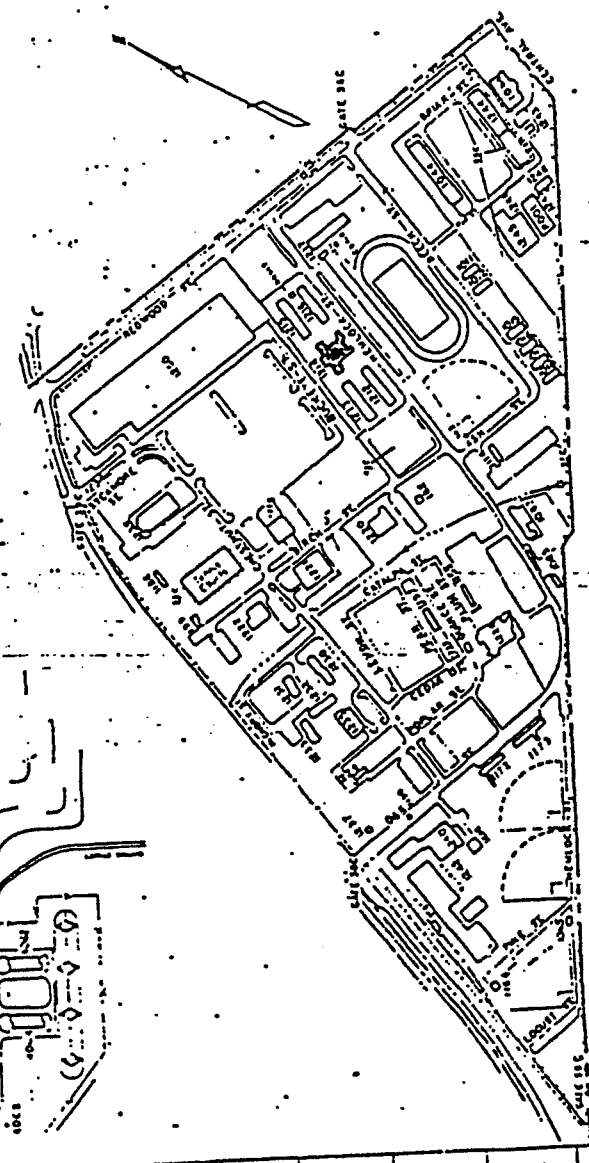

KITTYHAWK CENTER
SCALE 1" = 100'

A B C D E F G H I J K L M

APPENDIX D

DESIGN SCHEDULE

Proj. #	Title/Description	Cost	Status
890135 920148 920185 920222	Upgrade Wells Basewide. Replaces turbines with submersibles. Raises casing/vents above 100 year flood level to meet EPA Groundwater Under the Influence Rule.	900K	Awarded, construction to begin Feb 94
891010	Pipe Survey. Leak and pipe condition study.	9K	100% designed await. adver.
890160	Replace Gate Valves Basewide. Replaces 100 distribution gate valves.	350K	100% designed await. adver.
860146	Replace Valves/Engines. Replaces high and low service booster pumps and engines in Area B. Replaces gate and check valves associated with pumps.	220K	A/E design 5% designed
870073	Replace Valves. Replaces valves in Area B elevated tank pits.	57K	A/E design 5% designed
920016	Replace PIV Valves Basewide. Replaces 25 valves.	225K	A/E design 5% designed
900143	Replace Water Tower # 7 Replace 150KG tower.	662K	A/E design 5% designed
920066 920204	Replace Reservoir Roof/Reconnect Drains. EPA requirement to connect ground level reservoir drains indirectly to sanitary system. Replaces Area A reservoir roof.	87K	A/E design not awarded
880074	Replace Water Lines. Replaces line near Fac. 10281.	86K	In-house design 0%
930149	Replace Water Line/Valves. Replaces line near PM pool.	42K	In-house design 0%
930208	Replace Fluoridation System. Replaces fluoride system for housing areas from sodium fluoride to hydro. acid.	50K	In-house design 0%

Proj. #	Title/Description	Cost	Status
930191	Replace 14 Inch Main. Replaces line from Well E to SAC.	850K	In-house design 0%
940114	Replace Chlorine System. Replaces Area B Chlorine system.	24K	In-house design 0%

APPENDIX E

WATER TOWERS/RESERVOIRS FACTS

TOWERS

TOWER	GRD. EL.	BOT/BOWL	OVERFLOW	TOP/TANK	DIA.	CAP.
6	827.5	933.3	964.5	968.8	44	250,000
7	830.8	927.2	965.4	979.4	28	150,000
10	819.5	936.3	959.5	967.5	31	150,000
2	931.0	950.0	993.0	999.0	51	500,000
9	931.0	964.0	994.7	1000.7	36	200,000
8	970.0	1060.2	1090.9	1096.9	36	200,000

RESERVOIRS

RES	FILL INV.	OVERFLOW	FLOOR	DIS. INV.	DIA.	CAP.
1@2	836.4	836.4	823.0	822.6	*1	375,000
6	824.3	828.3	808.3	813.3	50	300,000
1	920.3	940.0*2	920.3	940.0	56	370,000
2	924.4	938.7	924.2	924.4	54	250,000
3	924.4	938.7	924.2	924.4	60	300,000

- *1-Sloping side walls.
- *2-Overflow is top of weir.

Tower Locations: 6-Area A, 7-Area C, 10-SAC, 2,8,@ 9-Area B
 Reservoir Locations: 1 @ 2-Area A, 6-Area C, 1,2, @ 3-Area B
 Tower 6 has 42 inch access tube in bowl.
 Reservoirs 1 @ 2 are connected via 10 inch pipe, capacity is per each reservoir.

All elevations, dimensions, and capacities are approximate and based on best available record drawing information. Values are rounded to the nearest 0.1 foot. Field verification has not been accomplished. For towers, where overflow elevations are not recorded, the overflow was assumed to be 6 feet below the top of the tower.

AIR STRIPPERS

AREA	BOT.	INFLUENT	EFFLUENT	OVERFLOW	DIA.	MAX. GPM
A	843.0	867.5	836.8	844.2	6.0	1900
B	925.5	971.9	944.0	949.0	9.5	4000
C	830.0	860.9	831.2	838.0	8.5	3500

Area A information based on design documents. Area B and Area C information based on as built documents.

c.j.v. June '92

APPENDIX F

1993 TRIANNUAL SAMPLING

SAMPLE LOCATION	DATE	TECHNICIAN	PARAMETERS	WATERBURY WATERBURY WATERBURY WATERBURY WATERBURY WATERBURY WATERBURY WATERBURY WATERBURY WATERBURY																
				WELL 1	WELL 2	WELL 3	WELL 4	WELL 5	WELL 6	WELL 7	WELL 8	WELL 9	WELL 10							
Nitrate	10	2.8	1.24	2.84	2.86	1.38	2.9	1.65	0.5	12.2	2.73	2.75	0.53	<0.05	<0.05	<0.05	<0.05	<0.05	<0.05	<0.05
Nitrite	1	<0.05	<0.05	<0.05	<0.05	<0.05	<0.05	<0.05	<0.05	<0.05	<0.05	<0.05	<0.05	<0.05	<0.05	<0.05	<0.05	<0.05	<0.05	<0.05
Fluoride	4	0.19	0.28	0.25	0.22	0.27	0.24	0.26	0.28	0.21	0.18	0.19	0.26	0.27	0.27	0.26	0.26	0.26	0.26	0.26
Chloride	250	88.7	49.5	56.6	60.5	55.6	44.9	41.7	50.9	55.3	59.2	53.7	187	72.8	88.7	364	392	342	448	468
Alkalinity	-	306	287	308	310	324	310	295	318	312	342	330	358	364	392	493	493	493	493	493
Hardness	-	495	368	376	453	424	448	416	499	416	451	432	615	519	493	493	493	493	493	493
Melatonin	0	102	96.5	100	96.5	99.9	95.9	95.2	98.4	95.9	107	105	110	116	120	116	120	116	116	116
Magnesium	-	36.5	34.8	35.7	34.9	34.3	35.1	32.4	33.6	33.4	37.3	37.6	36	41.2	36.5	40.1	40.1	40.1	40.1	40.1
Sodium	-	48.1	28.9	34.6	28.1	35.2	28.4	23.3	31.5	34.4	54.2	49	56.2	41.9	58	58.4	58	58	58	58
Aluminum	-	<0.1	<0.1	<0.1	<0.1	<0.1	<0.1	<0.1	<0.1	<0.1	<0.1	<0.1	<0.1	<0.1	<0.1	<0.1	<0.1	<0.1	<0.1	<0.1
Arsenic	0.05	<0.003	<0.003	<0.003	<0.003	<0.003	<0.003	<0.003	<0.003	<0.003	<0.003	<0.003	<0.003	<0.003	<0.003	<0.003	<0.003	<0.003	<0.003	<0.003
Barium	2	0.151	0.114	0.13	0.147	0.144	0.133	0.093	0.128	0.104	0.13	0.161	0.175	0.1	0.129	0.122	0.122	0.122	0.122	0.122
Cadmium	0.005	<0.001	<0.001	<0.001	<0.001	<0.001	<0.001	<0.001	<0.001	<0.001	<0.001	<0.001	<0.001	<0.001	<0.001	<0.001	<0.001	<0.001	<0.001	<0.001
Chromium	0.1	<0.005	<0.005	<0.005	<0.005	<0.005	<0.005	<0.005	<0.005	<0.005	<0.005	<0.005	<0.005	<0.005	<0.005	<0.005	<0.005	<0.005	<0.005	<0.005
Copper	-	0.026	0.025	0.071	<0.01	<0.01	<0.01	<0.01	<0.01	<0.01	0.016	<0.01	0.016	0.016	<0.01	<0.01	<0.01	<0.01	<0.01	<0.01
Iron	0.2	<0.04	<0.04	<0.04	<0.04	<0.04	0.051	<0.04	<0.04	<0.04	<0.04	<0.04	0.005	0.005	0.005	0.005	0.005	0.005	0.005	0.005
Lead	0.05	<0.002	<0.002	<0.002	<0.002	<0.002	<0.002	<0.002	<0.002	<0.002	<0.002	<0.002	<0.002	<0.002	<0.002	<0.002	<0.002	<0.002	<0.002	<0.002
Manganese	0.05	<0.1	0.023	<0.01	<0.01	<0.01	0.015	<0.01	<0.01	<0.01	<0.01	<0.01	0.039	0.066	0.094	0.105	0.105	0.105	0.105	0.105
Mercury	0.002	<0.0002	<0.0002	<0.0002	<0.0002	<0.0002	<0.0002	<0.0002	<0.0002	<0.0002	<0.0002	<0.0002	<0.0002	<0.0002	<0.0002	<0.0002	<0.0002	<0.0002	<0.0002	<0.0002
Selenium	0.05	<0.005	<0.005	<0.005	<0.005	<0.005	<0.005	<0.005	<0.005	<0.005	<0.005	<0.005	<0.005	<0.005	<0.005	<0.005	<0.005	<0.005	<0.005	<0.005
Silver	-	<0.001	<0.001	<0.001	<0.001	<0.001	<0.001	<0.001	<0.001	<0.001	<0.001	<0.001	<0.001	<0.001	<0.001	<0.001	<0.001	<0.001	<0.001	<0.001
Zinc	-	0.025	<0.01	<0.01	<0.01	<0.01	0.108	<0.01	<0.01	<0.01	0.011	<0.01	0.132	<0.01	<0.01	<0.01	<0.01	<0.01	<0.01	<0.01

**All units are in mg/l unless otherwise indicated by the parameters column

1993 TRIANNUAL SAMPLING

SAMPLER LOCATION	MCA	MCA		MCA		MCA		MCA		MCA		MCA		MCA		MCA		MCA		MCA	
		CONC.	UNIT	CONC.	UNIT	CONC.	UNIT	CONC.	UNIT	CONC.	UNIT	CONC.	UNIT	CONC.	UNIT	CONC.	UNIT	CONC.	UNIT	CONC.	UNIT
SVOCs (Cont.)																					
Chloroethene (4-)		<0.02		<0.02		<0.02		<0.02		<0.02		<0.02		<0.02		<0.02		<0.02		<0.02	<0.02
Hexachlorocyclopentadiene		<0.01		<0.01		<0.01		<0.01		<0.01		<0.01		<0.01		<0.01		<0.01		<0.01	<0.01
Chloro (4-) methylbenzene (3-)		<0.01		<0.01		<0.01		<0.01		<0.01		<0.01		<0.01		<0.01		<0.01		<0.01	<0.01
Methylcyclohexane (2-)		<0.01		<0.01		<0.01		<0.01		<0.01		<0.01		<0.01		<0.01		<0.01		<0.01	<0.01
Hexachlorocyclopentadiene	0.05	<0.01		<0.01		<0.01		<0.01		<0.01		<0.01		<0.01		<0.01		<0.01		<0.01	<0.01
Trichlorophenol (2,4,6-)		<0.01		<0.01		<0.01		<0.01		<0.01		<0.01		<0.01		<0.01		<0.01		<0.01	<0.01
Chlorophenol (2-)		<0.01		<0.01		<0.01		<0.01		<0.01		<0.01		<0.01		<0.01		<0.01		<0.01	<0.01
Nitroethene (2-)		<0.05		<0.05		<0.05		<0.05		<0.05		<0.05		<0.05		<0.05		<0.05		<0.05	<0.05
Dimethylmethane		<0.01		<0.01		<0.01		<0.01		<0.01		<0.01		<0.01		<0.01		<0.01		<0.01	<0.01
Acenaphthylene		<0.01		<0.01		<0.01		<0.01		<0.01		<0.01		<0.01		<0.01		<0.01		<0.01	<0.01
Dinitroethene (2,6-)		<0.01		<0.01		<0.01		<0.01		<0.01		<0.01		<0.01		<0.01		<0.01		<0.01	<0.01
Nitroethene (3-)		<0.06		<0.06		<0.06		<0.06		<0.06		<0.06		<0.06		<0.06		<0.06		<0.06	<0.06
Acenaphthene		<0.01		<0.01		<0.01		<0.01		<0.01		<0.01		<0.01		<0.01		<0.01		<0.01	<0.01
Dinitrophenol (2,4-)		<0.05		<0.05		<0.05		<0.05		<0.05		<0.05		<0.05		<0.05		<0.05		<0.05	<0.05
Nitrophenol (4-)		<0.05		<0.05		<0.05		<0.05		<0.05		<0.05		<0.05		<0.05		<0.05		<0.05	<0.05
Dibenzofuran		<0.01		<0.01		<0.01		<0.01		<0.01		<0.01		<0.01		<0.01		<0.01		<0.01	<0.01
Dinitroethene (2,6-)		<0.01		<0.01		<0.01		<0.01		<0.01		<0.01		<0.01		<0.01		<0.01		<0.01	<0.01
Dinitroethene (2,4-)		<0.01		<0.01		<0.01		<0.01		<0.01		<0.01		<0.01		<0.01		<0.01		<0.01	<0.01
Chlorophenol phenyl ether (4-)		<0.01		<0.01		<0.01		<0.01		<0.01		<0.01		<0.01		<0.01		<0.01		<0.01	<0.01
Fluorene		<0.01		<0.01		<0.01		<0.01		<0.01		<0.01		<0.01		<0.01		<0.01		<0.01	<0.01
Nitroethene (3-)		<0.06		<0.06		<0.06		<0.06		<0.06		<0.06		<0.06		<0.06		<0.06		<0.06	<0.06
Dinitro (2-) methylphenol (4,6-)		<0.06		<0.06		<0.06		<0.06		<0.06		<0.06		<0.06		<0.06		<0.06		<0.06	<0.06
Nitrosodiphenylamine-1(10-)		<0.01		<0.01		<0.01		<0.01		<0.01		<0.01		<0.01		<0.01		<0.01		<0.01	<0.01
Bromophenyl phenyl ether (4-)		<0.01		<0.01		<0.01		<0.01		<0.01		<0.01		<0.01		<0.01		<0.01		<0.01	<0.01
Hexachlorobenzene	0.001	<0.01		<0.01		<0.01		<0.01		<0.01		<0.01		<0.01		<0.01		<0.01		<0.01	<0.01
Perchlorophenol	0.001	<0.05		<0.05		<0.05		<0.05		<0.05		<0.05		<0.05		<0.05		<0.05		<0.05	<0.05
Phenanthrene		<0.01		<0.01		<0.01		<0.01		<0.01		<0.01		<0.01		<0.01		<0.01		<0.01	<0.01
Anthracene		<0.01		<0.01		<0.01		<0.01		<0.01		<0.01		<0.01		<0.01		<0.01		<0.01	<0.01
Carbazole		<0.01		<0.01		<0.01		<0.01		<0.01		<0.01		<0.01		<0.01		<0.01		<0.01	<0.01
Pyrene (Di-n-butyl)		<0.01		<0.01		<0.01		<0.01		<0.01		<0.01		<0.01		<0.01		<0.01		<0.01	<0.01

All units are in mg/l unless otherwise noted by the parameters

APPENDIX G

A New York

Upstate New York communities are using land-use regulations to protect the areas around municipal well-fields.

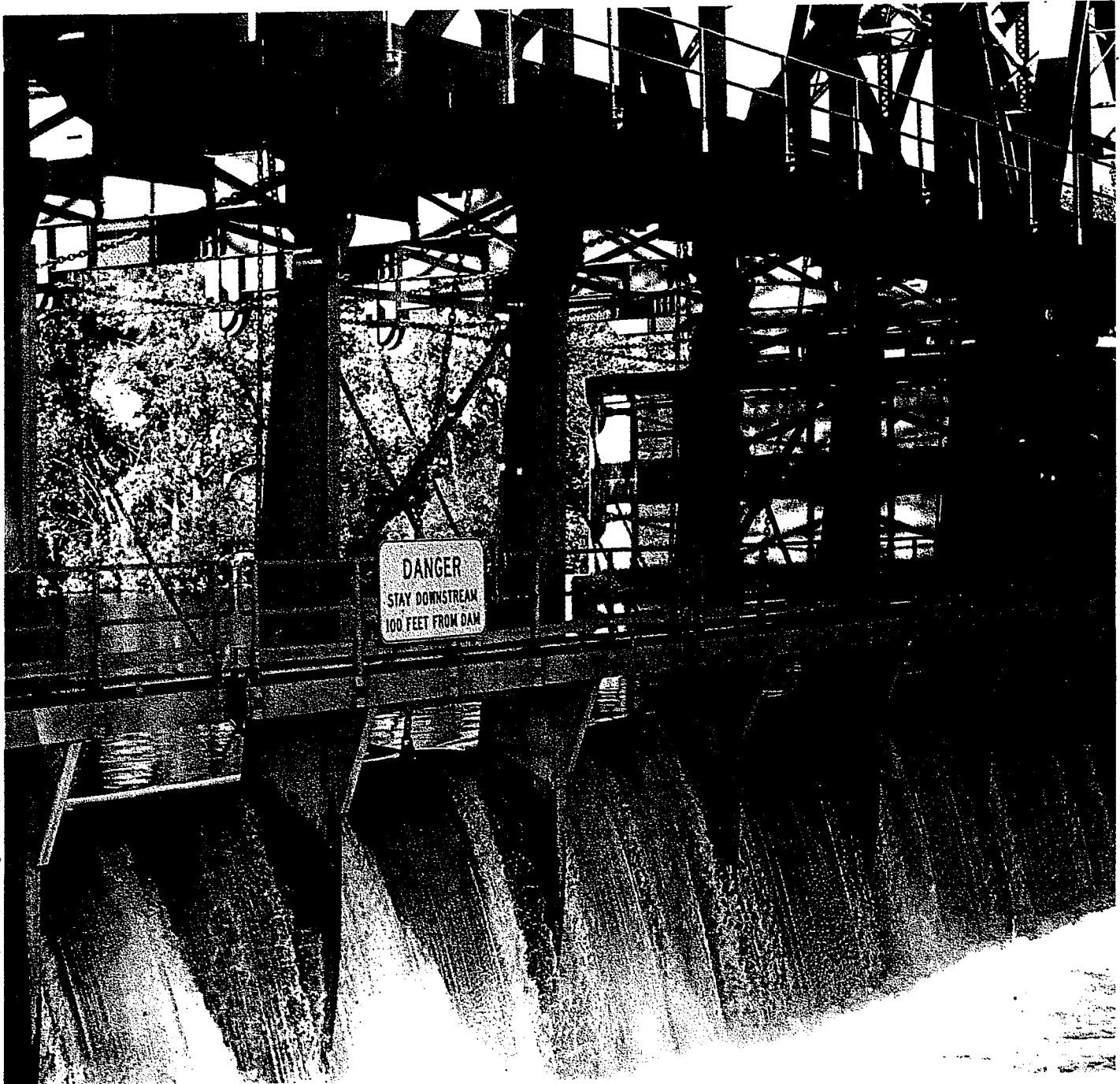

Courtesy of Schenectady County Planning Dept.

State of Mind

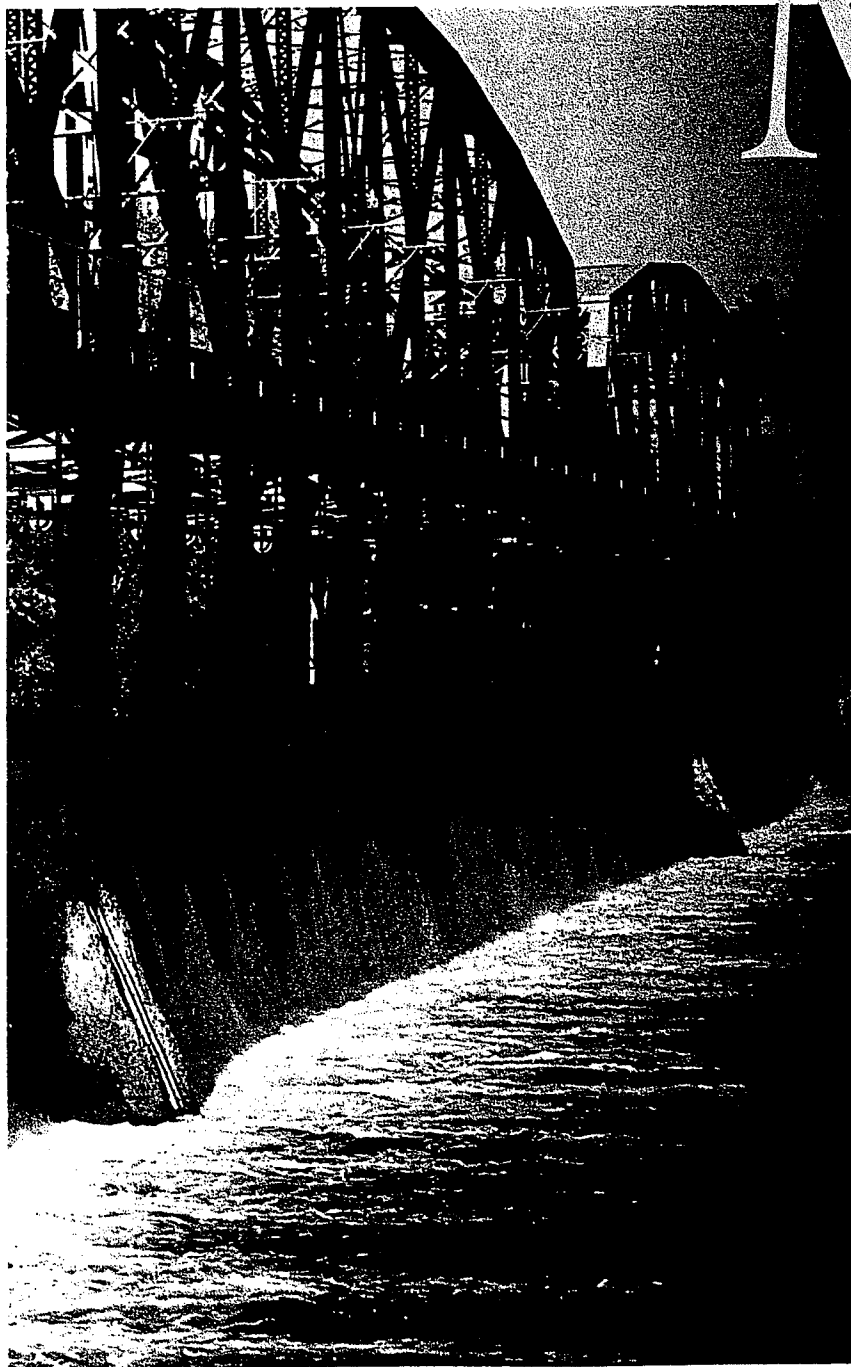

M

unicipalities served by a Schenectady (N.Y.) aquifer have joined together to create a unique aquifer and well-

head management plan. To avoid the conflicts likely to occur from multiple local regulations to protect a common resource, the group set up intermunicipal watershed rules and uniform land-use regulations for the protected areas. A key factor in the program's success was the creation of *well-head protection areas* (WHPAs) around each municipal well-field. The Schenectady program also considered the unique topographic and hydrogeologic conditions surrounding each of the municipal well-fields before developing the plan.

BACKGROUND AND HYDROGEOLOGY

The Schenectady Great Flats Aquifer, located along the Mohawk River in upstate New York, provides potable water to about 150,000 residential, business, and industrial users in five municipalities within Schenectady County (see Box, *The Schenectady Aquifer*). This valley fill aquifer currently yields about 1052 L/s (24 mgd).

In 1977, a 60,385 m² (650,000 ft²) regional shop-

Schenectady, N.Y., well-head protection program uses uniform intermunicipal rules and standards to protect groundwater

Kenneth J. Goldstein
Anne B. Benware
David M. Kutner



The Schenectady Aquifer

The Schenectady aquifer, a buried glacial drift aquifer typical of most valley fill aquifer systems in the northeastern U.S., is about 22.5 km (14 mi) long and underlies about 65 km² (25 mi²) in the lower Mohawk River in Schenectady County, N.Y. About 0.8 km (0.5 mi) wide at its western end, and more than 8 km (5 mi) wide at Schenectady to the east, the aquifer lies between the upland hills to the west, and the Hudson River lowlands to the east.

Bedrock underlying the Mohawk River valley in the Schenectady area is shale, overlain by glacial till in upland areas to the west and northwest and along a ridge at its eastern boundary, and by fine-grained glaciolacustrine sand, silt, and clay to the east and southeast.

The lower portion of the Mohawk Valley, near Schenectady and the western part of the main valley contain a thick sequence of unconsolidated sediments of coarse, well-sorted sand and gravel. As much as 107 m (350 ft) of unconsolidated glacial deposits filling a deep bedrock trough (the preglacial course of the Mohawk River) just west of Schenectady make up the principal portion of the aquifer, which is mostly under unconfined (water table) conditions. Most of the glacial deposits are covered by recent flood plain deposits, kames, comprised of highly permeable sand and gravel, are located in the northeastern part of the aquifer.

Some of the Schenectady well-field wells yield more than 221 L/s (3500 gpm) with less than 1.5 m (5 ft) of drawdown. The permeability of coarse sand and gravel deposits near the Schenectady and Rotterdam well-field ranges from 4074 to 12,222 m²/m²·d (100,000 to 300,000 gpd/ft²), while the aquifer's transmissivity in these locations ranges from an estimated 0.7 to 2.1 m²/m²·d (5 to 15 mgd/ft²).

ping mall was proposed just south of the Schenectady well-fields, in an area later determined to be within the primary recharge zone of the aquifer. The mall proposal brought together a range of divergent groups seeking to protect the aquifer; then, in 1978, the Schenectady County Aquifer Preservation Committee was formed to commission a hydrogeologic study of the aquifer. The study identified critical aquifer areas surrounding the cones of depression for the public wells and potential supply expansion areas. The study also characterized the aquifer's susceptibility to contamination from land uses adjacent to each of these critical areas and showed that the aquifer and its contributory zones overlapped municipal boundaries. These findings served as evidence that a coordinated intermunicipal program would be essential for protecting this resource.

However, during this earlier period, several, disparate protection efforts were attempted as each municipality proposed its own regulations. The New York State Department of Health offered an alternative strategy, recommending that the municipalities collectively pursue the creation of uniform rules and administrative standards to protect the aquifer. The Schenectady County Planning Department was asked to assist in this process.

The five municipalities that rely on the aquifer agreed

to form an Intermunicipal Watershed Rules and Regulations Committee. They executed a joint letter of commitment to initiate a uniform, comprehensive groundwater protection program and conduct an extensive aquifer assessment with the costs shared equitably. The evaluation included detailed maps of the sensitive aquifer zones that became the framework for the zonal regulatory approach used in the *Schenectady Intermunicipal Watershed Rules and Regulations*.

Meanwhile, the city of Schenectady petitioned the U.S. EPA to designate the Schenectady aquifer as a sole drinking-water source under provisions of the Safe Drinking Water Act (SDWA). This designation was granted in 1985.

LEGISLATIVE FRAMEWORK FOR WELL-HEAD PROTECTION

The Well-Head Protection Program (WHPP), established under the Safe Drinking Water Act amendments of 1986, allows states and municipalities to create programs to protect sole-source aquifers. A major element of the WHPP is determining protection zones around public supply well-fields (that is, WHPAs). These zones are defined in Section 1428(e) of the SDWA as "the surface and subsurface area surrounding a water well or well-field, supplying a public water system, through which contaminants are reasonably likely to move toward and reach such water well or well-field." The EPA, as the lead federal agency, has outlined criteria to provide state and local governments with a technical basis for WHPA delineation.

Building on the EPA zone of influence and zone of contribution WHPA delineation criteria, Schenectady County officials developed a four-zone approach to well-head and aquifer protection. Within each protection zone, actual site-specific hydrogeologic and topographic conditions formed the basis for delineating boundaries for the following four WHPAs around each of the well-fields: the *well-head protection zone* (zone of influence), the *primary recharge zone* (zone of contribution), the *general recharge zone* (protection of the most permeable aquifer areas) and the *tributary watershed zone* (surface water drainage basins) (see Figure, *Four-Zone Approach to Well-Head Protection*).

The well-head protection zone (Zone I), the most critical protection area, is the land adjoining public wells, extending to the limits of the cone of depression. The highest level of protection is recommended for this zone, ideally through public ownership of land and exclusive use for water supply facilities. In estimating the limits of the cone of depression, aquifer pumping tests were conducted at each of the municipal well-fields, using the maximum obtainable well yields. Drawdowns were measured in a network of observation wells installed at and in the vicinity of each well-field, and extrapolated (distance drawdown calculations) to the point of zero drawdown on the water table.

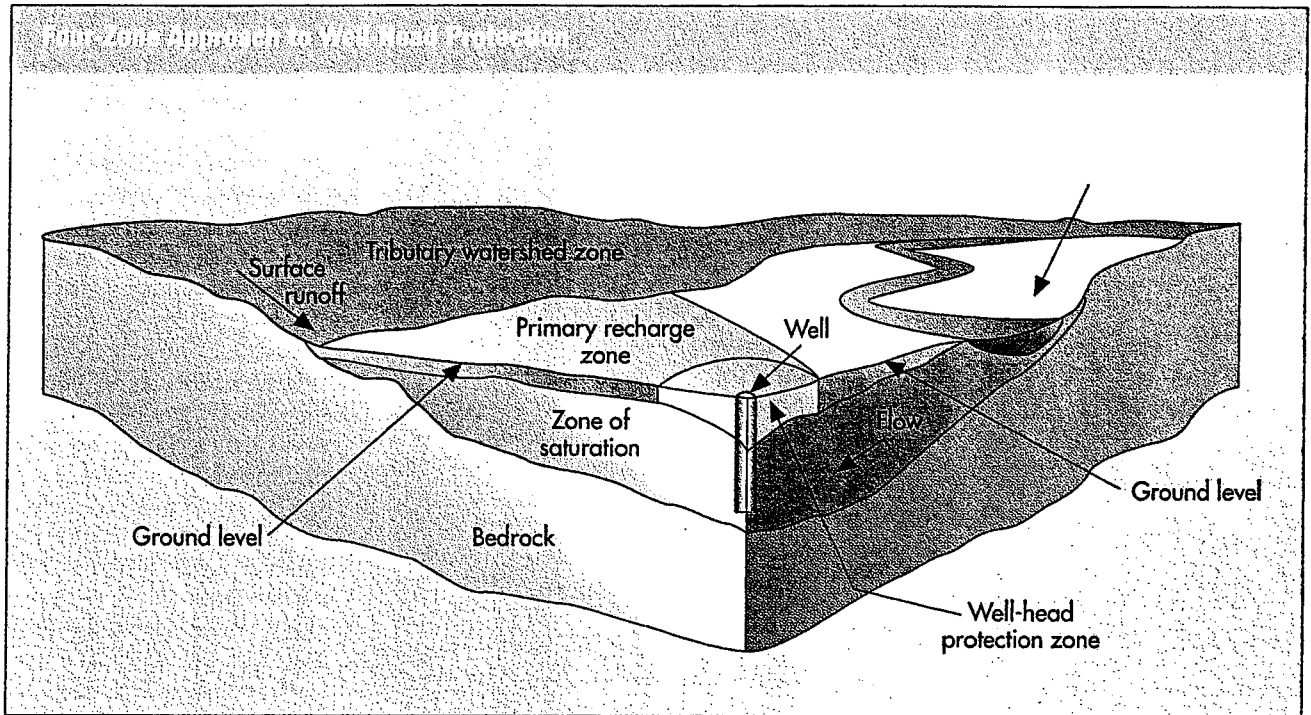

The primary recharge zone (Zone II), that part of the aquifer contributing groundwater to the public supply wells, generally extends hydraulically upgradient beyond the limits of the cone of depression to the groundwater divide or physical limits of the aquifer, and downgradient to the groundwater stagnation point (where groundwater flow is beyond the wells' influence of pumping). This zone may also encompass recharge boundaries such as rivers, lakes, and other surface water bodies that can contribute water to the wells.

The primary recharge zone was evaluated by assessing groundwater equipotential lines and flow lines caused by pumping the supply wells. Limiting flow lines were determined and translated into mappable boundaries of the primary recharge areas within which groundwater migrates toward the supply well(s) and is eventually captured.

The general aquifer recharge zone (Zone III) coincides with the Schenectady aquifer's mapped boundaries, encompassing the areal extent of the permeable sand and gravel deposits that comprise the aquifer. In this area, precipitation rapidly infiltrates into the ground, recharging the aquifer, and any contaminant released would rapidly migrate to the water table.

This area is protected for the potential future development of potable water sources for industry, the public, and private individual homeowner wells. Although most of the general recharge zone is remote to the municipal well-fields, Schenectady County officials felt it prudent to protect the entire aquifer for its ultimate use as a potable water source for county residents.

The tributary watershed area (Zone IV) includes the surface water drainage basins located in the

Mohawk Valley uplands. Within this zone, most runoff from precipitation flows overland and into defined stream beds until it reaches the general aquifer recharge zone, where it infiltrates and recharges the aquifer.

WHPA DELINEATIONS

After the first approximations of the well-head protection and the primary recharge zones were established, the second phase of the plan entailed installing a network of observation wells at each of the municipal well-fields, performing constant-rate 72-hour pumping tests, and evaluating test data. More than 80 observation wells were monitored during testing.

Because the interaction of surface water and groundwater was evident in the planning stages of the testing, special consideration was given to the season in which the tests were to be conducted.

Pumping tests were conducted after the river's navigation season to minimize the recharge effect of changes in the Mohawk River water level when the river's system of locks is operating.

Time-drawdown and distance-drawdown graphs

**The highest level
of protection is reserved
for the well-head protection
zone—ideally, means such
as public ownership of land
and exclusive use of water
supply facilities are used.**

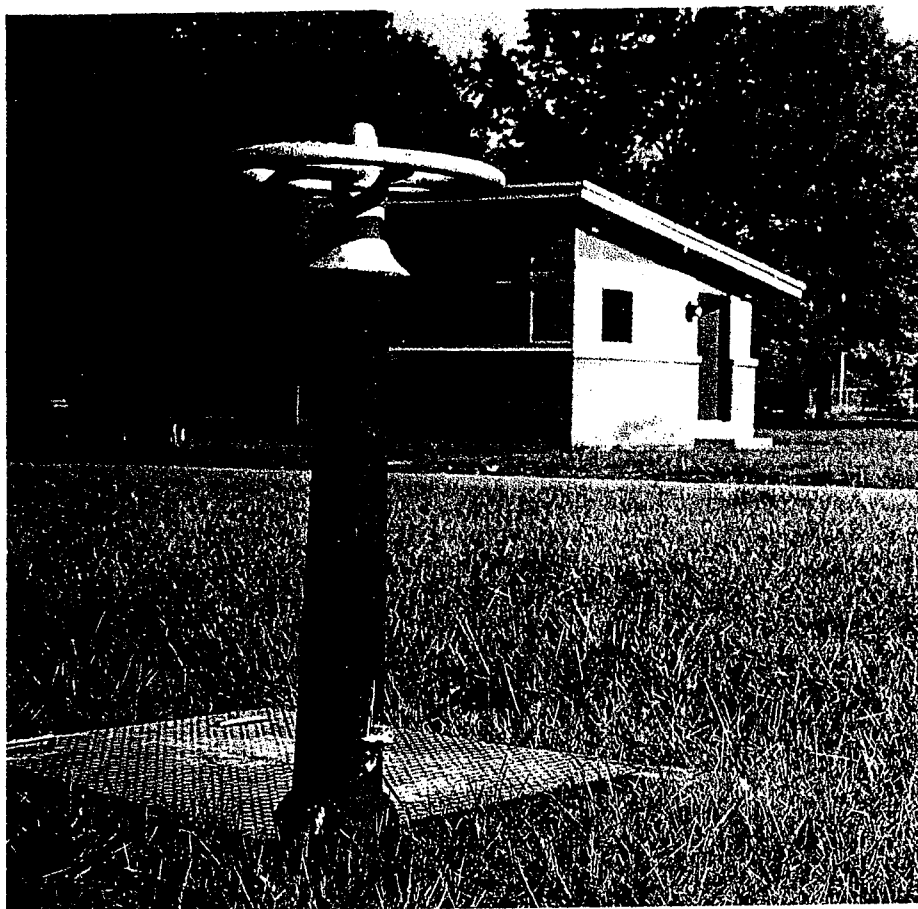

Courtesy of Schenectady County Planning Dept.

Each municipality that draws water from the Schenectady aquifer is involved in the enforcement of the watershed regulations.

produced from the aquifer pumping test data were used to establish aquifer characteristics and to estimate the amount of induced river infiltration to the well-fields. Based on time-drawdown data from the observation wells, aquifer transmissivities and storage coefficients were estimated, while aquifer drawdowns were extrapolated from distance-drawdown data to determine the maximum extent of the well-head protection zone (zero drawdown intercept).

Potentiometric surface contour maps for each of the well-fields were constructed from water level data. Groundwater equipotential lines and flow lines were analyzed in conjunction with time and distance drawdown data to delineate the boundaries of the well-head protection zone and primary recharge zone. The steepening of the hydraulic gradient west and south of the city of Schenectady and the town of Rotterdam well-fields revealed the hydraulic boundaries that limit the extent of the cone of depression. The map also showed that the area of influence extended below and beyond the Mohawk River. This clearly indicated that activities occurring in a town in which the supply wells were not located could have adverse impacts on the quality of water pumped. An analysis was performed for each municipal well-field to delineate the WHPAs. These mapped boundaries resulted in the New York

County municipalities. They have three major objectives:

- *Minimum standards.* Each public supply well-field should be protected by the minimum use and activity standards recommended by the NYSDOH.
- *Uniform application.* Equally sensitive aquifer areas should have equal protection, regardless of the municipal location; in addition, uses and activities posing the greatest risk of contamination should be restricted or prohibited uniformly.
- *Accountability.* Each municipality drawing water from the Schenectady aquifer becomes a partner in the creation, enforcement, and administration of the comprehensive watershed rules and regulations.

Limitations on land uses are most stringent within the well-head protection zone, and became successively less restrictive progressing to the tributary watershed zone. The watershed rules are divided into several sections, including general and specific provisions for each of the four zones.

In general, certain new uses or activities are prohibited within specific protection zones (for example, gasoline storage and sales within the primary recharge zone). However, currently operating prohibited uses become legally nonconforming and may remain active subject to completion and municipal acceptance of a property management plan. In disputes over the precise locations of zonal boundaries, affected property owners may petition the State Commissioner of Health

State Department of Health (NYSDOH) promulgating watershed rules and regulations based on the WHPA delineations.

INTERMUNICIPAL WATERSHED RULES AND REGULATIONS

After years of studying the Schenectady aquifer and reworking the regulatory language devised to protect it, the *Schenectady Intermunicipal Watershed Rules and Regulations* were finally adopted on the local level in 1990, and enacted by each municipality as part of its respective zoning law or ordinance.

The NYSDOH enacted slightly different watershed rules for the Schenectady aquifer in March 1992. The rules draw on the statutory authority granted to municipalities in New York to control land uses through zoning, and on the state's jurisdiction with respect to preservation of public water supplies.

The *Schenectady Intermunicipal Watershed Rules and Regulations* are a set of uniform land-use controls applicable to land overlying the aquifer within the five Schenectady

to request an adjustment by demonstrating, based on site-specific field analyses, that a boundary line was drawn incorrectly.

The standards established for each protection zone are cumulative, meaning that limitations established for land uses or other activities in a less critical zone are applicable in all more restrictive zones. Therefore, standards imposed on lands within Zone IV are also applicable in Zones III through I.

In the well-head protection zone, all land uses and development activities, other than those directly connected with the public water supply are prohibited, except for existing single-family homes and their septic systems. Bulk storage of coal or chloride salts, pesticide or fertilizer use, and mining operations are also prohibited, except existing, state-permitted operations that will not degrade water quality. Nine nonconforming uses in the three delineated well-head zones include an existing mining operation, a vehicle maintenance facility, and a park permitting recreational vehicles.

In the primary recharge zone, prohibited activities include those related to hazardous materials or toxic substances, solid waste management or treatment, and snow and ice disposal. Half of the 14 nonconforming uses within this zone are gas stations or other facilities using underground storage tanks.

Prohibited uses in the general aquifer recharge zone include landfills, salvage yards, injection wells not related to water supply, biosolids application, and disposal of snow collected off-site from roadways or parking areas into, or within 30 m (100 ft) of, any body of water. Other uses such as coal or salt storage, private water supply wells, and commercial pesticide storage are also regulated. Nonconforming uses are still unidentified within this zone.

In the tributary watershed zone, open storage of snow or ice collected off-site from roadways, agricultural chemicals and pesticides, and coal or chloride salts are prohibited within 30 m (100 ft) of any body of water. Other activities lacking applicable state permits are prohibited as well.

The watershed rules require that an annual inspection be conducted of all property located within a protection zone to determine compliance with the regulations. Inspection results, including information on any issued violations, incidents of contamination, and any reported spills and administrative activities, must be reported annually to the State Commissioner of Health.

To ensure due process for property owners, the State Health Commissioner may grant variances from the specific standards or restrictions of the watershed rules, subject to certain conditions.

IMPLEMENTING THE WATERSHED RULES

Once the watershed rules were adopted, the five aquifer municipalities were confronted with extensive

Property Management Plans for Nonconforming Uses Within Aquifer Protection Areas

Every owner of a nonconforming property or use is required to submit a property management plan (PMP) to the municipality in which the property is located. The PMP provides municipal officials with site-specific background information and technical data necessary to assess potential impacts to the aquifer from each nonconforming use. The process is designed to encourage and expand the use of best management practices to prevent aquifer contamination, to implement suitable spill response plans and on-site monitoring procedures, to provide technical assistance to property owners, and to provide for an efficient enforcement process. Because PMPs are approved subject to certain conditions, the approving municipality can require compliance by a property owner when such conditions are not met, under penalty of violation.

The plans include a narrative section that addresses:

- past and current uses of the property;
- condition, age, and type of storage facilities;
- site characteristics showing that the property is currently free of contamination based on federal and state standards;
- procedures for spill response, containment, and remediation;
- plans for continuous on-site monitoring;
- disposal methods for hazardous or toxic materials; and
- potential impacts to the aquifer from continued operation of the property.

The plan also contains a site plan showing existing and proposed structures and their respective uses; storage facilities, septic systems, and impervious surfaces; and topography, drainage patterns, stormwater management facilities, and grading plans.

administrative and enforcement responsibilities, primarily the need to identify every nonconforming use within each of the protection zones. Before the watershed rules were adopted, the county planning department had developed property inventory maps for the well-head protection and primary recharge zones encompassing the three delineated well-fields. Using tax assessment rolls, parcel maps and site visits, county planning staff worked with municipal officials to identify and notify the owners of all nonconforming properties located in Zones I and II. These property owners are required to submit a property management plan to the municipality in which their property is located (see Box, *Property Management Plans for Nonconforming Uses Within Aquifer Protection Areas*). ■

.....
Kenneth J. Goldstein is a certified hydrogeologist and an associate with Malcolm Pirnie, Inc., in Albany, N.Y.; **Anne B. Benware** is a land-use planner with the Schenectady County Department of Planning, Schenectady, N.Y.; and **David M. Kutner** is currently the town planner for the town of Framingham, Mass.