



NRL/MR/5712-95-7650

Launcher/Booster System Tradeoff Report

ALVIN CROSS

*Offboard Countermeasures Branch
Tactical Electronic Warfare Branch*

January 13, 1995

DTIC
ELECTE
JAN 26 1995
S G D

19950125 031

DTIC QUALITY INSPECTED 3

Approved for public release; distribution unlimited.

REPORT DOCUMENTATION PAGE

Form Approved
OMB No. 0704-0188

Public reporting burden for this collection of information is estimated to average 1 hour per response, including the time for reviewing instructions, searching existing data sources, gathering and maintaining the data needed, and completing and reviewing the collection of information. Send comments regarding this burden estimate or any other aspect of this collection of information, including suggestions for reducing this burden, to Washington Headquarters Services, Directorate for Information Operations and Reports, 1215 Jefferson Davis Highway, Suite 1204, Arlington, VA 22202-4302, and to the Office of Management and Budget, Paperwork Reduction Project (0704-0188), Washington, DC 20503.

| | | | |
|---|--|--|--------------------------------------|
| 1. AGENCY USE ONLY (<i>Leave Blank</i>) | 2. REPORT DATE January 13, 1995 | 3. REPORT TYPE AND DATES COVERED | |
| 4. TITLE AND SUBTITLE Launcher/Booster System Tradeoff Report | | 5. FUNDING NUMBERS PR - 57-3629-L5 | |
| 6. AUTHOR(S) Alvin Cross | | 8. PERFORMING ORGANIZATION REPORT NUMBER NRL/MR/5712--95-7650 | |
| 7. PERFORMING ORGANIZATION NAME(S) AND ADDRESS(ES) Naval Research Laboratory Washington, DC 20375-5320 | | | |
| 9. SPONSORING/MONITORING AGENCY NAME(S) AND ADDRESS(ES) Office of Naval Research Arlington, VA 22217-5660 | | 10. SPONSORING/MONITORING AGENCY REPORT NUMBER | |
| 11. SUPPLEMENTARY NOTES | | | |
| 12a. DISTRIBUTION/AVAILABILITY STATEMENT Approved for public release; distribution unlimited. | | 12b. DISTRIBUTION CODE | |
| 13. ABSTRACT (<i>Maximum 200 words</i>) This report describes the advantages of (and the need for) a ship-based portable booster system to support UAV operations. The specifications for such a system are defined and utilized as a tool to aid in the technology development selection process. A number of system types were preliminarily explored and descriptions are presented here. A tradeoff of applicable technologies is discussed. Based upon this tradeoff a selection of the most appropriate technology for further development is presented. | | | |
| 14. SUBJECT TERMS Launcher/Booster Super capacitor Hydraulic UAV | | 15. NUMBER OF PAGES 12 | |
| | | 16. PRICE CODE | |
| 17. SECURITY CLASSIFICATION OF REPORT UNCLASSIFIED | 18. SECURITY CLASSIFICATION OF THIS PAGE UNCLASSIFIED | 19. SECURITY CLASSIFICATION OF ABSTRACT UNCLASSIFIED | 20. LIMITATION OF ABSTRACT UL |

CONTENTS

| | |
|-----------------------------------|---|
| INTRODUCTION | 1 |
| APPROACH AND SPECIFICATIONS | 2 |
| TECHNOLOGY OPTIONS | 3 |
| SUMMARY | 7 |
| ACKNOWLEDGMENTS | 9 |
| REFERENCES | 9 |

| | |
|---------------------|-------------------------------------|
| Accession For | |
| NTIS CRA&I | <input checked="" type="checkbox"/> |
| DTIC TAB | <input type="checkbox"/> |
| Unannounced | <input type="checkbox"/> |
| Justification | |
| By | |
| Distribution / | |
| Availability Codes | |
| Dist | Avail and/or Special |
| A-1 | |

LAUNCHER/BOOSTER SYSTEM TRADEOFF REPORT

INTRODUCTION:

The Naval Research Laboratory has initiated an investigation of various existing technologies as a starting point for developing a viable electro-mechanical booster. The application of unmanned aircraft within the Navy's operational plan is severely hampered by the launching and storage limitations aboard a typical ship. Most of the current fleet inventory only has a relatively small area available for any flight operations. Currently those areas are almost totally dedicated to helicopter operations. The compact & portable specification for this unit pushes the design toward a system which will not only be usable in the limited area, but which will also be capable of coexisting with shipboard helicopter operations. Additionally, this booster would provide a much desired alternate method of deployment for principally ship-based unmanned, electronic warfare, decoy aircraft on ships which can currently support unmanned air vehicle operations (utilizing JATO, or rocket launch techniques). Numerous benefits can be derived from a ship-based portable booster system in support of unmanned air vehicles. Development of a compact, self contained booster system will provide support for the unmanned air vehicles utilized in the areas of: targeting / battle damage assessment; joint littoral warfare; ships defense; sea control (platform protection, point defense, tactical enablers); and training & readiness (assisting in providing realistic, validated weapons & threat tactics training). The booster would: eliminate the typical constraining requirement of MK36 launcher compatibility (increasing vehicle performance and mission capability); avoid the safety issues associated with a pyrotechnic launch; provide rapid deployment capability from virtually any ship in the current fleet inventory; provide a fully self contained unmanned air vehicle "system"; and allow an immediate response to threat without delay or compromise in the deployment of other ECM systems. The 6.2 program

under which the effort is tasked is the Electro / Aero / Mechanical EW Decoy Booster.

APPROACH:

The approach to this task has been established as a six step process:

1. Identification of applicable existing technologies
2. Testing of technology component hardware
3. Demonstration of system components or applicable systems
4. Technology integration
5. "Working system design"
6. Demonstration of a functional electro-booster on a qualified unmanned vehicle airframe

In order to implement the first step of this system approach, a set of preliminary requirements referenced to NRL's current technology base in the UAV area had to be established. The following list of requirements were set forth for the typical shipboard UAV:

- Vehicle weight capability: 35-70 pounds
- Capable of handling vehicle footprints of 4.5-10 inch dia. (adjustable)
- Total system weight : approx. 200 pounds
- Non-pyrotechnic launch
- Fully autonomous system (self-contained power supply and accessories)
- Compact stroke for mechanical systems: less than 10 ft. extended
- Alpha range: 45 - 90 degrees
- System life : greater than five years
- Three person maximum for safe operation
- Launch limit: 10-20 g (~100 milliseconds)
- Launch velocity: greater than 80 fps
- Rapid energy dissipation for system braking
- System recovery time: less than 5 minutes
- Direct system to operator feedback & launch assist
- Production costs less than \$50,000

With the establishment of these requirements as technology goals, NRL was able to begin its survey into the market for applicable technology and/or available systems. The tailored requirements were enough to eliminate some technologies from further consideration.

TECHNOLOGY OPTIONS:

Hydraulic Launch:

One system option was the hydraulic launch unit. This unit would be a scaled-down version of the Aquila Launch system. The basic concept utilizes compressed gaseous nitrogen as the power source for launch. The nitrogen is contained within gas/oil accumulators. The oil side of the accumulator is delivered to the launch cylinder, a piston connected to a moving crosshead of cable reeving with a 6:1 ratio. The cable is routed over the launch rail and back to a launch shuttle designed to "carry" the uav. Pressurization of the system is achieved by pumping hydraulic oil into the oil side of the accumulators for pre tensioning the cable and applying a force to the launch shuttle. When proper launch pressure is reached, the release mechanism, an electro-mechanical device, is actuated to start the launch sequence. The system's current release mechanism is programmed with an actuation cycle which is designed to lessen the rate of onset of acceleration. After release the shuttle is accelerated up the launch rail at a near constant rate of acceleration. At the end of the launcher's power stroke (10 to 12 ft.), the shuttle engages a nylon arresting tape, connected to a water brake, the shuttle comes to rest and the UAV is launched. The original system is well proven, however the designer maintains that a new system would still have significantly more mass and less flexibility than is required to function as a shipboard item. Additionally, the cost would be more than twice the established \$50 K production cost limit. A truck mounted version of this system was used by NRL as a small vehicle launch platform in the early 1980's during the LODED program.

Pneumatic Launch:

An interesting concept was presented by a small company, Southwest Virginian Research Corporation. This concept, known as the Land Harpoon, is a self contained, compressed air driven, stand-off delivery system capable of firing various projectiles to distances of greater than 500 ft. with a reliable degree of accuracy. The Land Harpoon is in effect a compressed air mortar with the capability of firing various projectiles at pre-determined pressures, from 15 psi to over 200 psi. The system is currently used in a fire fighting application. However, runs of a BASIC software program simulating the Land Harpoon's firing programs, indicate that the system could be adapted to use as a ballistic launch apparatus for UAVs. There are currently two demonstration systems available: 1) an 8 inch diameter barrel, and a 4 ft. barrel length fully manual system with a demonstrated capability of launching a 32 pound projectile up to 1500 ft. at a speed of 130 feet per second. 2) a 10 inch diameter barrel, and a 5 ft. length barrel system presently capable of launching up to a 56 pound projectile while requiring less than 180 psi for operation.

The system consists of an air chamber, barrel assembly, braking system, air compressor, and control panel. The air chamber is a cylindrical low pressure vessel capped by spherical ends with airtight seals. The chamber has two outlets: one provides inlet pressure to the air receiver, the other outlet links directly to the projectile (this outlet would be capped in a UAV application). A firing mechanism, air pressure equalizing tube, and barrel make up the barrel assembly. When the firing mechanism is actuated, air pressure forward of the projectile (vehicle) unseats the barrel cover and the resulting arterial force created helps pull the projectile from the barrel (assisting in a smooth overall acceleration, with a push-pull effect), while the air pressure behind the projectile is simultaneously propelling the unit through the barrel. The unit's prime component is the air compressor. Currently, the compressor may be either gas or diesel powered, producing at least 17.5 CFM with a 30 gallon compression tank rated for at least 250 psi. The unit may utilize simply compressed air or pre-compressed dry nitrogen.

The smaller of the two units has an overall cost of approximately \$35K. The larger diameter unit is available for approximately \$65K. Drawings of the current system and live test data are available in reference 2.

Supercapacitor Portable Booster Technology:

The idea of utilizing a series of low cost, high energy storage devices capable of providing rapid delivery of sustained power is very attractive to the launcher / booster concept. A prime candidate for this application seems to be the supercapacitor in its early stages of development by Lawrence Livermore National Labs. The capacitor utilizes a carbon aerogel base, which is a carbon based open cell foam with ultra fine pore size (<100 nm), high surface area (400-1000 sq. m/g), and a solid matrix of interconnected colloidal-like particles with diameters in the single digit nanometer range. A carbon aerogel is seen as the ideal supercapacitor material. It is electrochemically inert, monolithic with low electrical resistivity, and a relatively inexpensive and simple to produce material. For a one volt cell aqueous aerocapacitor, an average integrated capacitance of 34 Farads / cc could be realized. Calculations indicate that a one volt cell could provide approximately 17 Joules / cc. In terms of reliability and cycle life, the cells are predicted to be capable of over 65,000 cycles with less than a 20 percent reduction in overall capacitance.

A similar supercapacitor technology has been identified by Kaman Electromagnetics Corporation (KEC) as a component of an electric UAV launcher concept. The concept integrates a 10 ft. collapsible launch boom, portable electric generator, a lightweight pulsed rotary electric motor, and high energy density double-layered capacitors to provide pulsed power to the launch motor, and diagnostics to provide positive launch feedback of the launch acceleration and release velocity to the operator. This concept was presented as a more acceptable approach to lightweight UAVs as opposed to the use of linear electromagnetic launchers (which are the superior approach for launching full size aircraft or large scale drones, but are extremely costly and bulky).

The physical launcher concept utilizes a 10 ft. collapsible launch boom , with the unmanned air vehicle mounted to a traveling launch pad. The launch pad's motion is achieved by utilizing a captured rotating launching cable , which is started and kept in motion by a pulsed power rotary permanent magnet electric motor configured with a capstan drive to provide the torque necessary to launch vehicles with 4.5 to 10 inch diameter footprints and weights up to 75 pounds. A 1 kW generator will be required to provide power for charging the supercapacitors, which ultimately power the motor system.

The major concerns in this electric launcher system are the prime power, power conditioning, pulsed power energy storage, and structure. Prime power is necessary to provide a charging source for the pulsed power subsystem. This could most likely be supplied by ships service power, portable generator, or portable battery packs. KEC has recommended that the prime power capability be sized to allow a system recovery time of less than 5 minutes to meet the previously stated specifications. Presently, an estimate of 1 kW continuous power seems to be sufficient. Power conditioning is required to convert the prime power into a usable form to charge the double-layered capacitors driving the system motor. A combination of compact invertors and rectifiers, based on existing state of the art hardware, will be tailored to either a specific power source or to accommodate a variety of prime power sources to improve the launcher's versatility. The pulsed power energy storage is the most critical and emerging technology component of the system. Conventional film capacitors have energy densities in the 1-3 J/g range. This means that the capacitor mass would have to be around 30 kg for application to a UAV launcher. These capacitors have a fast discharge characteristic which would necessitate the use of a pulse forming network before delivering the power to the motor. These capacitors are moderately attractive. However, a new class of capacitors, the double-layered variety has recently been demonstrated to have an energy density an order of magnitude greater than the conventional film capacitors. This significant increase represents a great weight advantage for a "lightweight" system. Additionally, the double-layered capacitors have a naturally longer discharge time, increasing the time constants from hundreds of milliseconds to

seconds. This significantly reduces the structural requirements of both the launch vehicle and the launcher system. In terms of structure, the launch boom must react to the 1000 pound thrust load generated by the launch of a 70 pound UAV, along with the forces and moments generated by the pitching and heaving ship's deck. The structure must only withstand such loads for a short period of time (milliseconds). Using aircraft structures materials, and design criteria should allow fabrication of a fairly lightweight system. These double layer capacitors are being heavily investigated by numerous laboratories because of their possible applications for electric vehicle performance increases. These include Maxwell Laboratories Inc., Idaho National Engineering Laboratory, and Auburn University. In the automotive application, the double-layer capacitor would be utilized to provide peak power for acceleration, while the battery is used for "cruising". This practice is known as load leveling, and significantly reduces peak power requirements of a battery driven system. Early work sponsored by the Department of Defense and the Sohio Company at Auburn University lead to the production of a 35 kJ and a 0.5 MJ bank. Given these "high" numbers, it is evident that supercapacitor technology can support high electrical energy levels and high energy density requirements for lightweight power delivery systems.

Summary:

As can be seen from the information presented above, there are quite a few different and promising avenues available for a technology transition into the launcher/booster area. Each area presents certain concerns: 1) hydraulic launch appears to demand a bulky and rather expensive system; 2) available pneumatic launch hardware would still require significantly more complex vehicle configurations (i.e. wing and tail folding) to adapt to a larger, yet still constricting launch tube. 3) electric launch requires a significant power supply and somewhat more intensive safety measures. Each of the options must be concerned with the considerable risks posed by the unknown aspects of the early boost phase flight stability and control requirements. Meeting these requirements may indeed demand much more sophisticated hardware and its accompanying cost than anticipated. An

additional risk associated with the supercapacitor technology is the problem of sub component integration into an operating system. The level of complication and subsystems interference is relatively unknown. However, the higher dividends seem to lie in the development of the supercapacitor and ultimately the electric launcher concept should the risks and concerns be weighted against “payoff”. The system’s lightweight, low cost, rapid “turn around” capability, and optimal use of a relatively small power source are the concepts major selling points over and above the other options investigated.

Having designated the electric launcher concept as the prime candidate for further development, this block diagram gives a functional representation of the proposed launcher system:

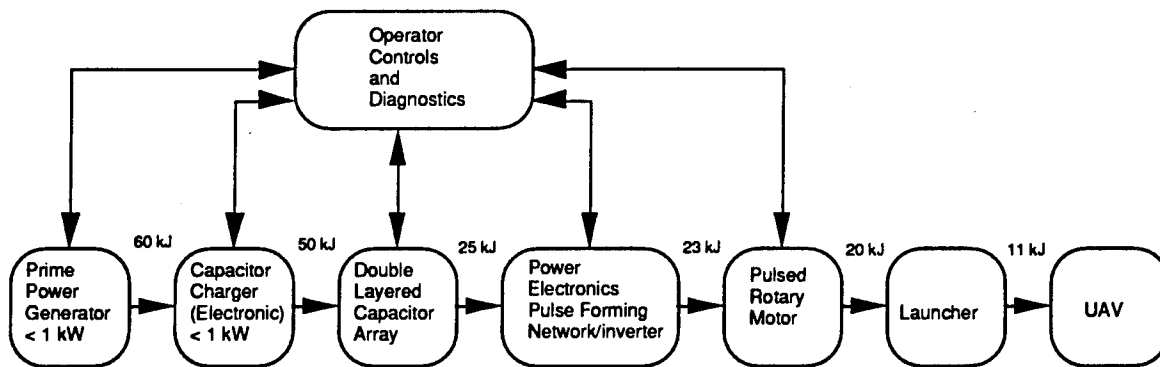

Power conditioning requirements, pulsed rotary motor technology, lightweight /compact structural design, controls and diagnostics, as well as safety areas must all be evaluated in depth in order to allow NRL to proceed with a safe, low cost, and fully functional prototype development for launcher demonstration. With receipt of requested funding in FY95, NRL will begin a systematic review of the individual components and their respective systems in the aforementioned areas. System design, followed by component and integration bench testing will begin immediately following the initial review.

UAV development at NRL has long been tied to the available shipboard launchers, which were not designed specifically for the UAV. The implications of a portable launch system are immense in terms of unmanned air vehicle capabilities and integration into the tactical, point defense, reconnaissance, and training areas pertinent to the Navy's mission, power projection and forward presence.

This work is sponsored by the Office of Naval Research(ONR).

References:

1. Lawrence Livermore National Laboratory, , "The Aerocapacitor: A Carbon Aerogel Based Supercapacitor", UCRL-JC-112652 (1992).
2. Land Harpoon Company, "Land Harpoon Operations Manual", (1992).
3. Kaman Electromagnetics Corporation, "A Concept for an Electric Launcher for Unmanned Aerial Vehicles (UAV)", (1994).