

# REPORT DOCUMENTATION PAGE

Form Approved  
OMB No. 0704-0188

Public reporting burden for this collection of information is estimated to average 1 hour per response, including the time for reviewing instructions, searching existing data sources, gathering and maintaining the data needed, and completing and reviewing the collection of information. Send comments regarding this burden estimate or any other aspect of this collection of information, including suggestions for reducing this burden, to Washington Headquarters Services, Directorate for Information Operations and Reports, 1215 Jefferson Davis Highway, Suite 1204, Arlington, VA 22202-4302, and to the Office of Management and Budget, Paperwork Reduction Project (0704-0188), Washington, DC 20503.

1. AGENCY USE ONLY (Leave blank)	2. REPORT DATE 00/00/76	3. REPORT TYPE AND DATES COVERED
----------------------------------	----------------------------	----------------------------------

4. TITLE AND SUBTITLE WATER TREATMENT AT ROCKY MOUNTAIN ARSENAL, PREOPERATIONAL AND PILOT TEST PLAN	5. FUNDING NUMBERS
--	--------------------

6. AUTHOR(S) WELLING, R.	
-----------------------------	--

7. PERFORMING ORGANIZATION NAME(S) AND ADDRESS(ES) ROCKY MOUNTAIN ARSENAL (CO.) COMMERCE CITY, CO	8. PERFORMING ORGANIZATION REPORT NUMBER  81341R25
---	--

9. SPONSORING/MONITORING AGENCY NAME(S) AND ADDRESS(ES)	10. SPONSORING/MONITORING AGENCY REPORT NUMBER
---	--

**DTIC**  
**ELECTE**  
**JAN 31 1995**  
**S G D**

11. SUPPLEMENTARY NOTES
-------------------------

12a. DISTRIBUTION/AVAILABILITY STATEMENT  APPROVED FOR PUBLIC RELEASE; DISTRIBUTION IS UNLIMITED	12b. DISTRIBUTION CODE
--	------------------------

13. ABSTRACT (Maximum 200 words)  THIS 10,000 GPH WATER TREATMENT PLANT TEST PLAN IS DESIGNED TO DEMONSTRATE THE PROPER FUNCTIONING OF ALL EQUIPMENT. THIS INCLUDES ALL MECHANICAL AND ELECTRICAL SYSTEMS CHECKOUTS, ESTABLISHING AND MAINTAINING A CARBON BED, AND IDENTIFYING ANY MODIFICATIONS DESIRED TO OPTIMIZE THE PROCESS. THIS IS AN INTERIM FACILITY DESIGNED TO DEMONSTRATE THE FEASIBILITY OF REMOVING DIMP AND DCPD FROM WATER AT A 10,000 GPH RATE USING A CARBON BED. THE BASIC CONCEPTS HAVE BEEN PROVEN ON THE 420 GPH TEST UNIT. INCLUDED WITH THIS PLAN IS THE OPERATORS' CHECKLIST FOR WATER TREATMENT FACILITY, INSTALLATION RESTORATION PROGRAM.  <p style="text-align: center;"><b>DTIC QUALITY INSPECTED 3</b></p>
--

14. SUBJECT TERMS  CARBON COAGULATION PROCESS, GROUNDWATER, SAFETY	15. NUMBER OF PAGES
	16. PRICE CODE

17. SECURITY CLASSIFICATION OF REPORT UNCLASSIFIED	18. SECURITY CLASSIFICATION OF THIS PAGE	19. SECURITY CLASSIFICATION OF ABSTRACT	20. LIMITATION OF ABSTRACT
---	--	---	----------------------------

81341R25  
original

WATER TREATMENT  
AT  
ROCKY MOUNTAIN ARSENAL

**FILE COPY**

PREOPERATIONAL AND PILOT TEST PLAN

Prepared By: *Richard Welling*  
RICHARD WELLING  
Industrial Engineer  
Installation Restoration

Reviewed By: *Bennie Saindon*  
BENNIE SAINDON  
Acting Chief, Safety Office

Rocky Mountain Arsenal  
Information Center  
Commerce City, Colorado

Reviewed By: *Carl Loven*  
CARL LOVEN  
Project Engineer  
Installation Restoration

Concurred In: *Irwin M. Glassman*  
IRWIN M. GLASSMAN  
Acting Director  
Installation Restoration

Approved By: *William G. Gibbons*  
WILLIAM G. GIBBONS  
LTC, CmIC  
Deputy Commander

19950127 087

Accession For	
NTIS CRA&I	<input checked="" type="checkbox"/>
DTIC TAB	<input type="checkbox"/>
Unannounced Justification	<input type="checkbox"/>
By _____	
Distribution / _____	
Availability Codes	
Dist	Avail and/or Special
A-1	

*File Tech*  
*Doc Tech*

TEST PLAN - 10,000 gph  
WATER TREATMENT PLANT

1. General - This 10,000 gph water treatment plant test plan is designed to demonstrate the proper functioning of all equipment. This includes all mechanical and electrical systems checkouts, establishing and maintaining a carbon bed, and identifying any modifications desired to optimize the process.
2. Objectives - This is an interim facility designed to demonstrate the feasibility of removing DIMP and DCPD from water at a 10,000 gph rate using a carbon bed. The basic concepts have been proven on the 420 gph test unit. Initial operating parameters will be determined by extrapolation from this test unit. Based on the interim nature of this project, the objectives to be achieved are as follows:
  - a. Demonstrate proper equipment functioning. This comprehensive checkout will verify operation of the electrical distribution system (switches, timers, etc.) and components (pumps) along with mechanical functions of system components (pumps, valves, piping, erdlator, etc.)
  - b. Develop and maintain a carbon bed.
  - c. Demonstrate that DIMP and DCPD can be removed to any prescribed level of detection at a 10,000 gph rate.
  - d. Define the operating curves (isotherms) for the facility.
  - e. Define modifications required in procedures or design to optimize the process.
3. Schedule - This test is estimated to require 25 normal duty days to perform. Initial planning is to perform the test between 29 Oct and 30 Nov. Test duration is variable, based on prevailing weather conditions.

The facility; in particular, the feed water and discharge water systems, is especially susceptible to freezing weather. The Denver region has a high probability of short freezes during the fall season; hence, variable delays in test duration are anticipated. The test is based on developing a steady-state isotherm using a fixed carbon bed and comparing this data with the results obtained during the same test on the 420 gph unit. Testing will be performed during normal duty hours, i.e., five days/week, eight hours/day. Two hours of each test day will be utilized to stabilize the system after transitions from the night recirculating mode to the normal operating mode. The schedule allows for one week of initial testing and debugging and four weeks of operational parameter testing.

4. Initial Preoperational Test - This test will demonstrate proper equipment functioning. Detailed procedures for accomplishing this task are provided in the preliminary "Operators' Checklist for Water Treatment Facility," dated 28 Sep 76. A general system process diagram is attached for reference. All tests will be performed using bog water only. Test duration is estimated at one week. The key elements of this test are:

a. Check operation of feed pump and repair leaks in components common to all operating modes. This test is basically performed by closing the control valves for major component drains, recirculation and product water discharge, opening the feed water valve, turning on the feed pump, filling the system to capacity, and turning off the feed pump and closing the feed valve. The pump is tested for electrical/mechanical functioning and the flow rate is measured. The system is left filled for 24 hours; and any leaks are repaired, if feasible, or noted for future corrective action.

b. Check operation of discharge pump and repair leaks in components unique to the recirculation system. This test basically consists of starting with the system filled (conclusion of test in a above), opening the recirculation valve, and turning on the discharge pump. The pump is tested for electrical/mechanical functions and the flow rate is measured (using the orifice plate and gauge in the feed system). Any leaks are repaired, if feasible, or noted for future corrective action.

c. Check operation of the erdlator agitator pump. The pump is turned on, operated for two hours, and checked for electrical/mechanical functioning.

d. Check operation in the normal operating mode. The system is changed from the recirculating mode to the normal operating mode by opening the discharge and feed valves, closing the recirculation valve, and turning on the feed pump. Prior to changing modes, the tanks for cationic, anionic, and carbon feed systems are to be filled with water. After repairing any leaks found, the timed pumps for the cationic, anionic, and carbon feed systems will be switched to manual ON and checked for proper electrical/mechanical functioning. At this stage, the timers will be checked for proper functioning at various settings. The system will be returned to the recirculation mode to remain in a standby status unless draining is essential to permit repair actions.

5. Final Preoperational Test - This test will develop a constant carbon bed and define the steady-state isotherm. Detailed procedures for accomplishing the carbon bed development are provided in the preliminary "Operators; Checklist for Water Treatment Facility," dated 28 Sep 76.

A general system process diagram is attached for reference. Test duration is estimated at four weeks. The key elements of this test are as follows:

a. Fill the cationic and anionic tanks with chemicals at the concentration specified by the Project Engineer.

b. Establish the system in the standby recirculating mode of operation. Set the cationic and anionic timers to values specified by the Project Engineer. These initial values will be extrapolated from the stabilized values developed on the 420 gph test bed facility. Allow the system to stabilize before proceeding.

c. Gradually add carbon to the system in the amount specified by the Project Engineer. The carbon will be added directly at the top of the erdlator. Allow the system to form a stabilized carbon bed.

d. With the establishment of a stabilized fixed carbon bed, the system will be placed in the normal operating mode each day and switched to the standby recirculating mode each evening (to maintain the carbon bed). Approximately two hours will be required at the beginning of each day for the system to stabilize in the normal operation mode after switching from the recirculating mode.

e. Product water samples will be taken at least twice per day (at noon and at the end of the duty day). These samples will be analyzed for DIMP, DCPD, p-chlorophenyl methyl sulfide, sulfone, sulfoxide, and total organic carbon. The waters' characteristic fingerprint will be identified. From this data, the steady-state system isotherms will be developed. Other key system paramenters (feed water rate, temperature, pH, TDS, turbidity, start-up time, stable operations time, etc.) will be maintained on the daily shift operations log. Critical shift operations parameters can then be correlated to the date attained from the product water samples.

FEED  
WATER

f. This test phase will be terminated by the Project Engineer when he has determined that necessary and sufficient data is available to reliably define the systems fixed bed steady-state isotherm.

6. Summary - At the conclusion of testing, the system will be drained and provided protection in areas susceptible to weather damage. Based on the test results along with experience gained during the continuing testing on the 420 gph test bed facility, recommendations for system modifications required to optimize the process will be developed. The results obtained and recommendations developed will be included in the system test final report.

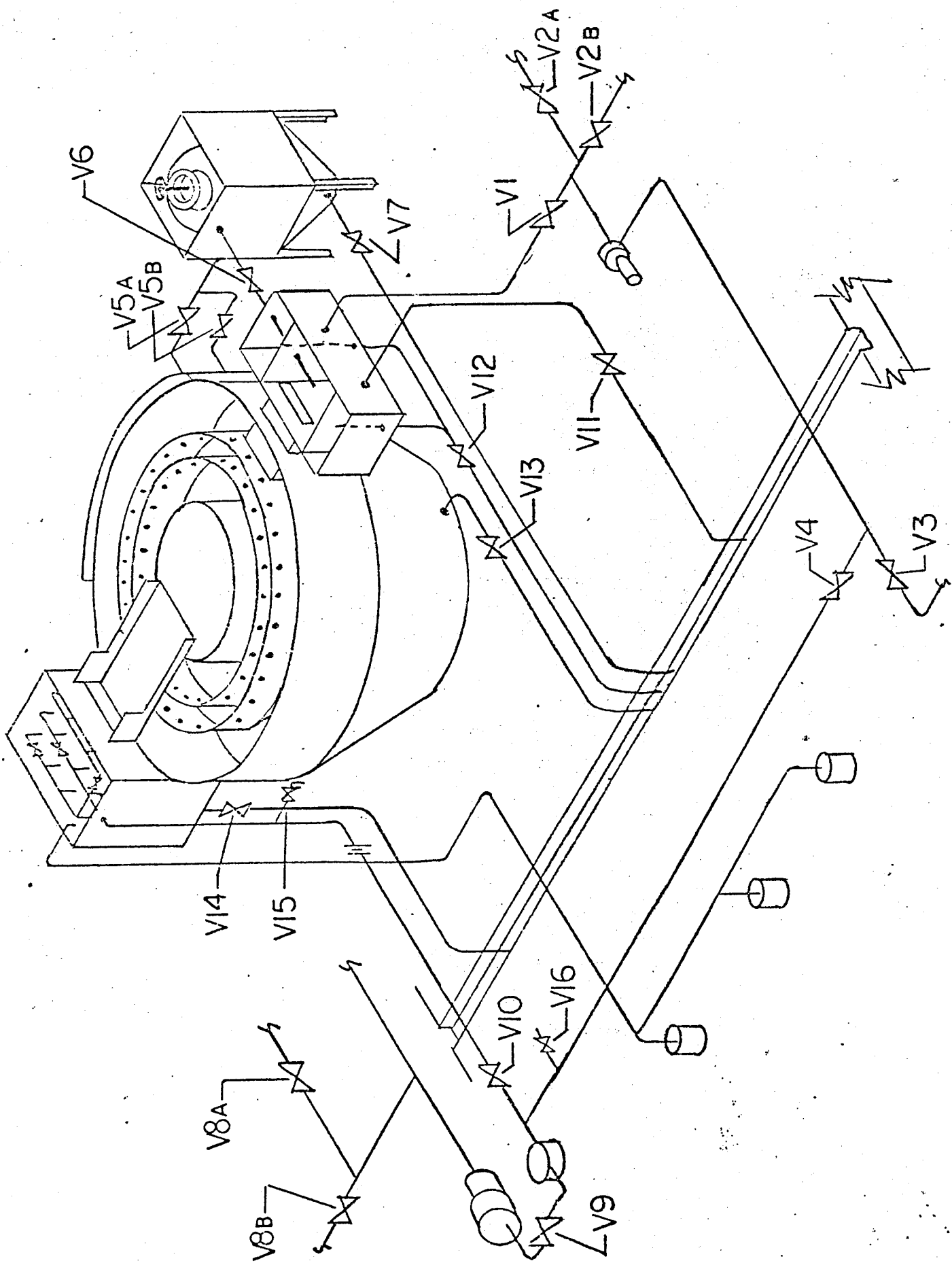

VALVE DIAGRAM ERDLATOR SECTION

RATIONALE FOR 10,000 PLANT LIMITED OPERATIONS

1. Primary purpose of original plant proposal was to demonstrate a "working plant" using the carbon coagulation process for a period of 30 - 60 days.
2. Data obtained during this period would provide indisputable evidence as to degree of actual removal of various contaminants under field conditions.
3. The actual hands-on operating experience will identify deficiencies in equipment and/or operations and provide sufficient lead time to make corrections and verify the change.
4. Limited carbon bed operations will allow for the correlations of actual operating data between the 420 and 10,000 gallon units and lead to a high degree of confidence when extrapolating data from future pilot studies. Pilot studies can more meaningfully replace large-scale plant operations in determining optimum process conditions, etc.
5. Raw materials have been purchased and are on site.
6. Sufficient operating personnel for a limited duration test are available.
7. Actual operations would be extremely important in the estimation of O&M costs for FY 78 future plant operations.

CL-IR-XXX-X

OPERATORS' CHECKLIST  
FOR  
WATER TREATMENT FACILITY

INSTALLATION RESTORATION  
PROGRAM

DEPARTMENT OF THE ARMY  
ROCKY MOUNTAIN ARSENAL

LIST OF EFFECTIVE PAGES

Total Number of Pages in this Publication: 27

Consisting of the Following:

PAGE	ISSUED
Title -----	Orig
A -----	Orig
i thru ii -----	Orig
1-1 thru 1-6 -----	Orig
2-1 thru 2-5 -----	Orig
3-1 thru 3-3 -----	Orig
4-1 thru 4-4 -----	Orig
5-1 thru 5-2 -----	Orig
6-1 thru 6-3 -----	Orig

Date of issue for original  
pages is 28 Sep 76

CL-IR-XXX-X

## INTRODUCTION

This checklist is a step-by-step guide in abbreviated form for use as a reference to ensure accomplishment of selected tasks by a predetermined sequence procedure. The intent of this checklist is to eliminate the probability of omission of a step in the accomplishment of the intended task. The procedures contained herein are presented in the shortest practical form for use by qualified personnel and are not intended to provide full technical instructions. This checklist provides sequenced procedures for performing the Installation Restoration Water Treatment Process.

## TABLE OF CONTENTS

FUNCTION	PAGE
1. Perform Water Treatment Facility Preoperational Test -----	1-1
2. Perform Water Treatment Facility Initial Startup -----	2-1
3. Perform Water Treatment Facility Startup from Standby -----	3-1
4. Perform Water Treatment Facility Operating Procedures -----	4-1
5. Perform Water Treatment Facility Shutdown to Standby -----	5-1
6. Perform Water Treatment Facility Shutdown -----	6-1

PERFORM WATER TREATMENT FACILITY PREOPERATIONAL TEST

Preliminary Instructions:

a. Operator numbers required:

1

b. Special tools:

None

c. Technical data required:

System flow sheet

d. System requirements:

None

e. Time to complete:

Variable

f. Safety requirements:

This function must be performed in the sequence given. Each step must be accomplished before continuing to the next. Notify shift engineer if for any reason a step cannot be performed.

## NOTE

This procedure will be utilized to verify system function and to initially calibrate system components. The system will be operated without the carbon processing components. When a discrepancy is noted, the system should be shut down and repair action taken prior to proceeding.

- |  |               |
|--|---------------|
| 1. Discharge pump to irrigation valve (#3) to CLOSED.      | Set _____     |
| 2. Discharge pump recycled water valve (#4) to OPEN.       | Set _____     |
| 3. Filter tanks to discharge pump valve (#2) to OPEN.      | Set _____     |
| 4. Wetwell to filter tanks valve (#1) to OPEN.             | Set _____     |
| 5. Erdalator to concentrator valve (#5) to CLOSED.         | Set _____     |
| 6. Concentrator to wetwell valve (#6) to CLOSED.           | Set _____     |
| 7. Concentrator to evaporation ponds valve (#7) to CLOSED. | Set _____     |
| 8. Verify all power switches are in the OFF position.      | Checked _____ |

NOTE: The above valving setup places the system in the recirculating standby configuration.

- |   |               |
|---|---------------|
| 9. Feed water pump power switch to ON.  | Set _____     |
| 10. Check electrical operation of pump, i.e., no overheating, overcurrent, etc. | Checked _____ |
| 11. Check pump operation, i.e., visually verify flow rate.                      | Checked _____ |

CL-IR-XXX-X

12. Check water meter for correct operation. Checked \_\_\_\_\_
13. Check for water leaks at all connections, pump, meter, orifice, aerator, erdalator, wetwell, and valves. This should be accomplished prior to water reaching the filter tanks. Checked \_\_\_\_\_
14. After water reaches the filter tanks, switch discharge pump power to ON. Set \_\_\_\_\_
15. Check electrical operation of pump, i.e., no overheating, overcurrent, etc. Checked \_\_\_\_\_
16. Check pump operation, i.e., visually verify flow rate. Checked \_\_\_\_\_
17. Check for water leaks at all connectors, pump, filter tanks, and valves. Checked \_\_\_\_\_

NOTE: The system is now basically operating in the standby recirculating mode.

18. Measure and record the flow rate for the feed water pump. Logged \_\_\_\_\_
19. When the system is full, switch the feed water pump power to OFF. Set \_\_\_\_\_
20. Measure and record the flow rate for the discharge pump. Logged \_\_\_\_\_
21. Fill the cationic tank with water and check for leaks. Checked \_\_\_\_\_
22. Fill the anionic tank with water and check for leaks. Checked \_\_\_\_\_
23. Fill the carbon tank with water and check for leaks. Checked \_\_\_\_\_

NOTE: If excess water begins to develop in the system during the following tests, open the discharge pump to irrigation valve (#3) to bleed off the excess.

- |     |   |               |
|-----|---|---------------|
| 24. | Set the cationic timer to manual ON.  | Set _____     |
| 25. | Check electrical operation of timer switch and cationic pump, i.e., no overheating, overcurrent, etc. | Checked _____ |
| 26. | Check pump operation, i.e., visually verify flow rate.  | Checked _____ |
| 27. | Check for water leaks at all connectors and cationic pump.  | Checked _____ |
| 28. | Measure and record the flow rate of the cationic pump.  | Logged _____  |
| 29. | Verify operating times for cationic timer labelled positions. Record any differences noted.           | Logged _____  |
| 30. | Set cationic timer to OFF.  | Set _____     |
| 31. | Set the anionic timer to manual ON.   | Set _____     |
| 32. | Check electrical operation of timer switch and anionic pump, i.e., no overheating, overcurrent, etc.  | Checked _____ |
| 33. | Check pump operation, i.e., visually verify flow rate.  | Checked _____ |
| 34. | Check for water leaks at all connectors and anionic pump.   | Checked _____ |
| 35. | Measure and record the flow rate of the anionic pump.   | Logged _____  |

CL-IR-XXX-X

36. Verify operating times for anionic timer labelled positions. Record any differences noted.

Logged \_\_\_\_\_

37. Set anionic timer to OFF.

Set \_\_\_\_\_

38. Set the carbon timer to manual ON.

Set \_\_\_\_\_

39. Check electrical operation of timer switch and carbon pump, i.e., visually verify flow rate.

Checked \_\_\_\_\_

40. Check pump operation, i.e., visually verify flow rate.

Checked \_\_\_\_\_

41. Check for water leaks at all connectors and carbon pump.

Checked \_\_\_\_\_

42. Measure and record the flow rate of the carbon pump.

Logged \_\_\_\_\_

43. Verify operating times for carbon timer labelled positions. Record any differences noted.

Logged \_\_\_\_\_

44. Set carbon timer to OFF.

Set \_\_\_\_\_

45. Set the carbon agitator power to ON.

Set \_\_\_\_\_

46. Check agitator for proper operation.

Checked \_\_\_\_\_

47. Set the carbon agitator power to OFF.

Set \_\_\_\_\_

48. Concentrator to evaporation ponds valve (#7) to OPEN.

Set \_\_\_\_\_

49. Concentrator to wet well valve (#6) to OPEN.

Set \_\_\_\_\_

50. Evaporator sump valve (#5) to OPEN.

Set \_\_\_\_\_

51. Discharge pump to irrigation valve (#3) to OPEN.

Set \_\_\_\_\_

CL-IR-XXX-X

52. Discharge pump recycled water valve (#4) to CLOSED.

Set \_\_\_\_\_

53. Feed water pump power to ON.

Set \_\_\_\_\_

NOTE: The system is now in the operating mode, with the exception of cationic, anionic, and carbon feeds. The system is functioning with water only.

54. Check all connections, valves, and concentrator for leaks, plugging, etc.

Checked \_\_\_\_\_

55. Feed water pump power to OFF.

Set \_\_\_\_\_

56. Allow system to drain or close concentrator to evaporation ponds valve (#7) and discharge pump to irrigation valve (#3) to seal system. This decision will be furnished by the shift engineer.

Set \_\_\_\_\_

57. Furnish project engineer with summary of timer accuracies, pump flow rates, and corrective actions taken.

Reported \_\_\_\_\_

PERFORM WATER TREATMENT FACILITY INITIAL STARTUP

Preliminary Instructions:

a. Operator numbers required:

1

b. Special tools:

None

c. Technical data required:

System flow sheet

d. System requirements:

None

e. Time to complete:

2 days (1 to fill system, 1 to establish bed)

f. Safety requirements:

This function must be performed in the sequence given.  
Each step must be accomplished before continuing to the next.  
Notify shift engineer if for any reason a step cannot be performed.

## NOTE

Performance of Steps 1 through 9 can be deferred if tanks are full to at least 1/3 capacity. This will permit mixing to be performed using product water.

- |  |               |
|--|---------------|
| 1. Mix cationic to prescribed solution to bring cationic tank to full level.   | Mixed _____   |
| 2. Thoroughly stir cationic solution to assure uniform blending.   | Stirred _____ |
| 3. Enter mixing data on shift operations log.  | Logged _____  |
| 4. Mix anionic to prescribed solution to bring anionic tank to full level.   | Mixed _____   |
| 5. Thoroughly stir anionic solution to assure uniform blending.  | Stirred _____ |
| 6. Enter mixing data on shift operations log.  | Logged _____  |
| 7. Mix carbon to prescribed solution to bring carbon tank to full level. Add carbon slowly to allow thorough wetting and to prevent coagulation. | Mixed _____   |
| 8. Carbon tank agitator power to ON.   | Set _____     |
| 9. Enter mixing data on shift operations log.  | Logged _____  |
| 10. Enter feed water meter reading on shift operations log.  | Logged _____  |
| 11. Recycled water valve (#4) to OPEN.   | Set _____     |
| 12. Discharge pump valve to irrigation (#3) CLOSED.  | Set _____     |

CL-IR-XXX-X

13. Filter tank valve to discharge pump (#2) OPEN. Set \_\_\_\_\_
14. Wetwell valve to fill tanks (#1) OPEN. Set \_\_\_\_\_
15. Sludge valve from eructor (#5) CLOSED. Set \_\_\_\_\_
16. Concentrator to wetwell valve (#6) CLOSED. Set \_\_\_\_\_
17. Spent carbon valve from concentrator to evaporation ponds (#7) CLOSED. Set \_\_\_\_\_
18. Feed water pump power to ON. Set \_\_\_\_\_
19. Check system for leaks or plugging at valves, joints, branches, etc. Checked \_\_\_\_\_
20. Wait for system to fill with feed water and then set feed water pump power to OFF. Set \_\_\_\_\_
21. Enter feed water meter reading on shift operations log. Logged \_\_\_\_\_
22. Cationic pump timer set to specifications provided by shift engineer. Set \_\_\_\_\_
23. Log cationic pump timer setting on shift operations log. Logged \_\_\_\_\_
24. Anionic pump timer set to specifications provided by shift engineer. Set \_\_\_\_\_
25. Log anionic pump timer setting on shift operations log. Logged \_\_\_\_\_
26. Check cationic and anionic systems for leaks or plugging. Checked \_\_\_\_\_
27. Carbon pump timer set to specifications provided by shift engineer. Set \_\_\_\_\_

CL-IR-XXX-X

- 28. Log carbon pump timer setting on shift operations log. Logged \_\_\_\_\_
- 29. Check carbon feed system for leaking, plugging, etc. Checked \_\_\_\_\_
- NOTE: Steps 1 through 9 may have to be repeated to establish a stabilized carbon bed.
- 30. Wait for system to stabilize and carbon bed to be established. Established \_\_\_\_\_
- 31. Discharge pump to irrigation valve (#3) set to OPEN. Set \_\_\_\_\_
- 32. Discharge pump recycled water valve (#4) set to CLOSED. Set \_\_\_\_\_
- 33. Enter feed water meter reading on shift operations log. Logged \_\_\_\_\_
- 34. Feed water pump power to ON. Set \_\_\_\_\_
- 35. Set cationic pump timer to specifications established by shift engineer. Set \_\_\_\_\_
- 36. Enter cationic pump timer setting on shift operations log. Logged \_\_\_\_\_
- 37. Set anionic pump timer to specifications established by shift engineer. Set \_\_\_\_\_
- 38. Enter anionic pump timer setting on shift operations log. Logged \_\_\_\_\_
- 39. Set carbon pump timer to specifications established by shift engineer. Set \_\_\_\_\_
- 40. Enter carbon pump timer setting on shift operations log. Logged \_\_\_\_\_

CL-IR-XXX-X

- 41. Erdalator sludge valve (#5) to OPEN. Set \_\_\_\_\_
- 42. Concentrator to wetwell valve (#6) to OPEN. Set \_\_\_\_\_
- 43. Concentrator to evaporation ponds valve (#7) to OPEN. Set \_\_\_\_\_
- 44. Investigate total system for leaks, plugging, etc. Checked \_\_\_\_\_

PERFORM WATER TREATMENT FACILITY STARTUP FROM STANDBY

Preliminary Instructions:

- a. Operator numbers required:

1

- b. Special tools:

None

- c. Technical data required:

System flow sheet

- d. System requirements:

Shutdown to standby procedure completed

- e. Time to complete:

30 minutes

- f. Safety requirements:

This function must be performed in the sequence given. Each step must be accomplished before continuing to the next. Notify shift engineer if for any reason a step cannot be performed.

## NOTE

It is assumed the system is full, a carbon bed is established, and the system is in the standby recirculation mode.

- |   |              |
|---|--------------|
| 1. Set cationic pump timer to specifications established by shift engineer. | Set _____    |
| 2. Enter cationic pump timer setting on shift operations log.               | Logged _____ |
| 3. Set anionic pump timer to specifications established by shift engineer.  | Set _____    |
| 4. Enter anionic pump timer setting on shift operations log.                | Logged _____ |
| 5. Set carbon pump timer to specifications established by shift engineer.   | Set _____    |
| 6. Enter carbon pump timer setting on shift operations log.                 | Logged _____ |
| 7. Enter feed water meter reading on shift operations log.                  | Logged _____ |
| 8. Discharge pump to irrigation valve (#3) set to OPEN.                     | Set _____    |
| 9. Discharge pump recycled water valve (#4) set to CLOSED.                  | Set _____    |
| 10. Erdalator sludge valve (#5) set to OPEN.                                | Set _____    |
| 11. Concentrator to wetwell valve (#6) set to OPEN.                         | Set _____    |
| 12. Concentrator to evaporation ponds valve (#7) set to OPEN.               | Set _____    |
| 13. Feed water pump power set to ON.  | Set _____    |

CL-IR-XXX-X

14. Check system for leaks, plugging, etc.

Checked \_\_\_\_\_

PERFORM WATER TREATMENT FACILITY OPERATING PROCEDURES

Preliminary Instructions:

a. Operator numbers required:

1

b. Special tools:

None

c. Technical data required:

System flow sheet

d. System requirements:

Initial startup or startup from standby procedures completed

e. Time to complete:

Variable

f. Safety requirements:

This function must be performed in the sequence given. Each step must be accomplished before continuing to the next. Notify shift engineer if for any reason a step cannot be performed.

## NOTE

It is assumed the system is in the operational mode through performance of the initial startup or startup from standby procedures, the system is full, and a carbon bed is established.

- |  |               |
|--|---------------|
| 1. Mix full tank of cationic solution using product water to specifications established by the shift engineer. | Mixed _____   |
| 2. Thoroughly stir cationic mix to assure complete blending.   | Stirred _____ |
| 3. Enter mix data on shift operations log.   | Logged _____  |
| 4. Mix full tank of anionic solution using product water to specifications established by the shift engineer.  | Mixed _____   |
| 5. Thoroughly stir anionic mix to assure complete blending.  | Stirred _____ |
| 6. Enter mix data on shift operations log.   | Logged _____  |
| 7. Mix full tank of carbon solution using product water to specifications established by the shift engineer.   | Mixed _____   |
| 8. Carbon tank agitator power to ON.   | Set _____     |
| 9. Enter mix data on shift operations log.   | Logged _____  |
| 10. Enter feed water meter reading on shift operations log.  | Logged _____  |
| 11. Check system for leaks, plugging, etc.   | Checked _____ |
| 12. Enter the startup time on the shift operations log.  | Logged _____  |
| 13. Enter the stable operations time on the shift operations log.  | Logged _____  |

**NOTE:** If the second feed water meter reading is taken an even hour after the first reading, computation of the feed water flow rate will be simplified. All feed and product water measurements should be taken within one hour after the second feed water meter reading.

14. After stable operations are established and at least one hour after the last reading, enter the second feed water meter reading in the shift operations log. Logged \_\_\_\_\_
15. Enter the temperature reading for the feed water on the shift operations log. Logged \_\_\_\_\_
16. Enter the pH measurement of the feed water on the shift operations log. Logged \_\_\_\_\_
17. Enter the total dissolved solids (TDS) measurement for the feed water on the shift operations log. Logged \_\_\_\_\_
18. Enter the turbidity measurement for the feed water on the shift operations log. Logged \_\_\_\_\_
19. Enter the temperature reading for the product water on the shift operations log. Logged \_\_\_\_\_
20. Enter the pH measurement of the product water on the shift operations log. Logged \_\_\_\_\_
21. Enter the total dissolved solids (TDS) measurement for the product water on the shift operations log. Logged \_\_\_\_\_
22. Enter the turbidity measurement for the product water on the shift operations log. Logged \_\_\_\_\_

CL-IR-XXX-X

23. Prepare a product water sample for laboratory analysis approximately 2½ hours after the shift startup. Enter the time of sampling on the shift operations log.

Logged \_\_\_\_\_

24. Prepare a product water sample for laboratory analysis approximately 5 hours after the shift startup. Enter the time of sampling on the shift operations log.

Logged \_\_\_\_\_

25. Prepare a product water sample for laboratory analysis at the end of shift operations. Enter the time of sampling on the shift operations log.

Logged \_\_\_\_\_

26. Prior to the end of the shift, complete the calculations on the shift operations log and enter the results on the log.

Logged \_\_\_\_\_

NOTE: Tables of common values for these calculations are available from the shift engineer to simplify calculations.

~~PERFORM~~ WATER TREATMENT FACILITY SHUTDOWN TO STANDBY

Preliminary Instructions:

a. Operator numbers required:

1

b. Special tools:

None

c. Technical data required:

System flow sheet

d. System requirements:

System is in operating mode

e. Time to complete:

30 minutes

f. Safety requirements:

This function must be performed in the sequence given. Each step must be accomplished before continuing to the next. Notify shift engineer if for any reason a step cannot be performed.

## NOTE

It is assumed the system is in the operational mode and a carbon bed is established.

- |   |         |       |
|---|---------|-------|
| 1. Feed water pump power to OFF.  | Set     | _____ |
| 2. Discharge pump recycled water valve (#4) to OPEN.                        | Set     | _____ |
| 3. Discharge pump to irrigation valve (#3) to CLOSED.                       | Set     | _____ |
| 4. Sludge valve (#5) to CLOSED.   | Set     | _____ |
| 5. Concentrator to wetwell valve (#6) to CLOSED.                            | Set     | _____ |
| 6. Concentrator to evaporation ponds valve (#7) to CLOSED.                  | Set     | _____ |
| 7. Cationic pump timer to OFF.  | Set     | _____ |
| 8. Anionic pump timer to OFF.   | Set     | _____ |
| 9. Carbon pump timer to OFF.  | Set     | _____ |
| 10. Enter shutdown time and the word "standby" on the shift operations log. | Logged  | _____ |
| 1. Check system for leaks, plugging, etc.                                   | Checked | _____ |

PERFORM WATER TREATMENT FACILITY SHUTDOWN

Preliminary Instructions:

a. Operator numbers required:

1

b. Special tools:

None

c. Technical data required:

System flow sheet

d. System requirements:

System is either in the standby or operational modes

e. Time to complete:

30 minutes

f. Safety requirements:

This function must be performed in the sequence given. Each step must be accomplished before continuing to the next. Notify shift engineer if for any reason a step cannot be performed.

NOTE

The system may be either in the standby or operational modes at the start of this procedure. Determine the system mode and begin at the appropriate portion of the checklist.

From Operational Mode:

- 1. Feed water pump power to OFF. Set \_\_\_\_\_
- 2. Cationic pump timer to OFF. Set \_\_\_\_\_
- 3. Anionic pump timer to OFF. Set \_\_\_\_\_
- 4. Carbon pump timer to OFF. Set \_\_\_\_\_
- 5. Continue with Step 6 of this checklist.

From Standby Mode:

- 1. Discharge pump to irrigation valve (#3) to OPEN. Set \_\_\_\_\_
- 2. Discharge pump recycled water valve (#4) to CLOSED. Set \_\_\_\_\_
- 3. Sludge valve (#5) to OPEN. Set \_\_\_\_\_
- 4. Concentrator to wetwell valve (#6) to OPEN. Set \_\_\_\_\_
- 5. Concentrator to evaporator ponds valve (#7) to OPEN. Set \_\_\_\_\_

Common Instructions:

- 6. Allow total system to drain. Drained \_\_\_\_\_

CL-IR-XXX-X

7. Discharge pump power to OFF.
8. Carbon tank agitator power to OFF.
9. Clean out carbon tank.
10. Enter shutdown time in shift operations log.

Set \_\_\_\_\_

Set \_\_\_\_\_

Cleaned \_\_\_\_\_

Logged \_\_\_\_\_

**ROCKY MOUNTAIN ARSENAL WATER TREATMENT FACILITY  
SHIFT OPERATIONS LOG -- PREOPERATIONS PHASE**

DATE \_\_\_\_\_

SHIFT \_\_\_\_\_

**INITIAL SETUP -- MIXING OPERATIONS**

	<u>Weight Chemical</u>	<u>Volume H<sub>2</sub>O</u>	<u>Concentration</u>	<u>Time Mixed</u>	<u>Operator's Initials</u>
Cationic/H <sub>2</sub> O	_____ gms	_____ gal	_____ ppm	_____	_____
Anionic/H <sub>2</sub> O	_____ gms	_____ gal	_____ ppm	_____	_____
Carbon/H <sub>2</sub> O	_____ lbs	_____ gal	_____ lbs/ gal	_____	_____

**SHIFT OPERATING PARAMETERS**

	<u>Meter Reading</u>	<u>Time of Observation</u>	<u>Flow Rate</u>	<u>Temp</u>	<u>pH</u>	<u>TDS</u>	<u>Turbidity</u>
FI H <sub>2</sub> O	(1) _____	(1) _____					
	(2) _____	(2) _____	_____ gpm	_____ OF	_____	_____	_____
Product H <sub>2</sub> O				_____ OF	_____	_____	_____

	<u>Timer Setting</u>	<u>Feed Rate</u>	<u>Verified By</u>	<u>Time</u>
Cationic Feed	_____	_____ ppm	_____	_____
Anionic Feed	_____	_____ ppm	_____	_____
Carbon Feed	_____	_____ gms/hr	_____	_____

	<u>Time</u>
Startup	_____
Stable Operations	_____
Shutdown	_____
Product H <sub>2</sub> O Sample	_____

REMARKS: