

ROBOT ASSISTED MATERIAL HANDLING
FOR SHIRT COLLAR MANUFACTURING
-- TURNING AND PRESSING --
DLA 900-87-0017 Task 0004

FINAL REPORT

VOLUME III:

Double Point Turning Machine

CENTER FOR ADVANCED MANUFACTURING

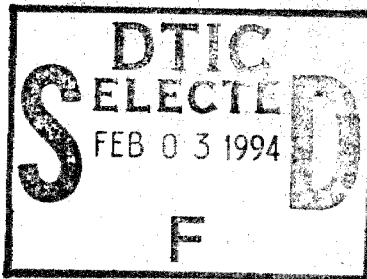

This document has been approved
for public release and sale; its
distribution is unlimited.



CLEMSON
UNIVERSITY

College of Engineering
Clemson, South Carolina 29634

DTIC QUALITY INSPECTED 3

ROBOT ASSISTED MATERIAL HANDLING
FOR SHIRT COLLAR MANUFACTURING
-- TURNING AND PRESSING --
DLA 900-87-0017 Task 0004

FINAL REPORT

VOLUME III:

Double Point Turning Machine

Frank W. Paul
Principal Investigator

and

Shlomo Avigdor
Research Assistant

Center for Advanced Manufacturing
and
Clemson Apparel Research

Clemson University
Clemson, SC

June 1992

DTIC QUALITY INSPECTED 3

19950130 020

Accession For	
NTIS CRA&I	<input checked="" type="checkbox"/>
DTIC TAB	<input type="checkbox"/>
Unannounced	<input type="checkbox"/>
Justification	
By	
Distribution /	
Availability Codes	
Dist	Avail and/or Special
A-1	

REPORT DOCUMENTATION PAGE

1a. REPORT SECURITY CLASSIFICATION Unclassified		1b. RESTRICTIVE MARKINGS										
2a. SECURITY CLASSIFICATION AUTHORITY		3. DISTRIBUTION / AVAILABILITY OF REPORT Unclassified Distribution Unlimited										
2b. DECLASSIFICATION / DOWNGRADING SCHEDULE		4. PERFORMING ORGANIZATION REPORT NUMBER(S)										
4. PERFORMING ORGANIZATION REPORT NUMBER(S)		5. MONITORING ORGANIZATION REPORT NUMBER(S)										
5a. NAME OF PERFORMING ORGANIZATION Clemson University/ Clemson Apparel Research	6b. OFFICE SYMBOL (if applicable)	7a. NAME OF MONITORING ORGANIZATION Defense Personnel Support Center										
6c. ADDRESS (City, State, and ZIP Code) 500 Lebanon Road Pendleton, SC 29670		7b. ADDRESS (City, State, and ZIP Code) 2800 South 20th Street P.O. Box 8419 Philadelphia, PA 19101-8419										
8a. NAME OF FUNDING / SPONSORING ORGANIZATION Defense Logistics Agency	8b. OFFICE SYMBOL (if applicable)	9. PROCUREMENT INSTRUMENT IDENTIFICATION NUMBER DLA 900-87-D-0017 Delivery Order 0004										
8c. ADDRESS (City, State, and ZIP Code) Room 4B195 Cameron Station Alexandria, VA 22304-6100		10. SOURCE OF FUNDING NUMBERS <table border="1" style="width:100%; border-collapse: collapse; margin-top: 5px;"> <tr> <td style="width:25%;">PROGRAM ELEMENT NO.</td> <td style="width:25%;">PROJECT NO.</td> <td style="width:25%;">TASK NO.</td> <td style="width:25%;">WORK UNIT ACCESSION NO.</td> </tr> <tr> <td>78011S</td> <td></td> <td></td> <td></td> </tr> </table>		PROGRAM ELEMENT NO.	PROJECT NO.	TASK NO.	WORK UNIT ACCESSION NO.	78011S				
PROGRAM ELEMENT NO.	PROJECT NO.	TASK NO.	WORK UNIT ACCESSION NO.									
78011S												
11. TITLE (Include Security Classification) Robot Assisted Material Handling for Shirt Collar Manufacturing: Turning and Pressing Vol. III: Double Point Turning Machine - unclassified												
12. PERSONAL AUTHOR(S) F. W. Paul, Principal Investigator; Shlomo Avigdor, Research Assistant												
13a. TYPE OF REPORT Final	13b. TIME COVERED FROM n/a TO	14. DATE OF REPORT (Year, Month, Day) 1992 June 23	15. PAGE COUNT 150									
16. SUPPLEMENTARY NOTATION												
17. COSATI CODES <table border="1" style="width:100%; border-collapse: collapse; margin-top: 5px;"> <tr> <th style="width:33%;">FIELD</th> <th style="width:33%;">GROUP</th> <th style="width:33%;">SUB-GROUP</th> </tr> <tr> <td> </td> <td> </td> <td> </td> </tr> <tr> <td> </td> <td> </td> <td> </td> </tr> </table>		FIELD	GROUP	SUB-GROUP							18. SUBJECT TERMS (Continue on reverse if necessary and identify by block number)	
FIELD	GROUP	SUB-GROUP										
19. ABSTRACT (Continue on reverse if necessary and identify by block number) This document presents Volume III of the report of research into the automation of shirt collar manufacturing using robotic methods. Presented is the proof-of-concept model of an automated collar turning machine for double point collars, as well as an evaluation of the machine's ability to successfully accomplish this high-dexterity task, with good quality and enhanced speed, as compared to manual methods.												
20. DISTRIBUTION / AVAILABILITY OF ABSTRACT <input checked="" type="checkbox"/> UNCLASSIFIED/UNLIMITED <input type="checkbox"/> SAME AS RPT. <input type="checkbox"/> DTIC USERS		21. ABSTRACT SECURITY CLASSIFICATION Unclassified										
22a. NAME OF RESPONSIBLE INDIVIDUAL Frank W. Paul		22b. TELEPHONE (Include Area Code) 803-656-3291	22c. OFFICE SYMBOL									

ACKNOWLEDGMENTS

The authors would like to thank all those who were involved with support of this project. Especially, it is appropriate to thank the Defense Logistics Agency, Department of Defense, for support of this work under contract number DLA 900-87-0017 Task 0004. This work was conducted through Clemson Apparel Research, a facility whose purpose is the advancement of apparel manufacturing technology and by the Center for Advanced Manufacturing, Clemson University.

ABSTRACT

The trend of automating machinery use in the textile area is continually growing. This project documents the development of the first proof-of-concept collar turning machine. This study concerns the design and evaluation of a double point collar turning machine. The concept is based on the number of fixed centers by which it is feasible to turn the collar.

Developed in the Robotics and Machine Automation Laboratory of Clemson University, the double point collar turning machine is designed to be controlled by a personal computer. Loading and unloading of the collar from the turning machine can be accomplished by a robot or human operator. The machine is capable of locating the collar points and turning the collar automatically.

Approximately five hundred military style collars were turned by the proof-of-concept model, at a speed at least twice that for manual collar turning. The collar turning machine process results in good quality turned collars, comparable to hand turned collars.

The turning machine was integrated into a workstation which turns and aligns shirt collars for pressing without human intervention. This study indicated that the pivot turner machine is capable of turning a collar with good quality. The turning machine has the potential for design enhancements which can improve its performance.

TABLE OF CONTENTS

	Page
TITLE PAGE	i
ABSTRACT	ii
ACKNOWLEDGEMENTS	iii
LIST OF TABLES	vi
LIST OF FIGURES	vii
CHAPTER	
I. INTRODUCTION	1
Background	1
Purpose	3
Objectives	3
Project Tasks.....	3
Project Organization	4
II. METHODS FOR COLLAR TURNING	5
History of Collar Turning and Pressing...	5
Evaluation of Manual Turning on the Lunapress.....	8
Commercially Available Turning and Pressing Machines.....	11
Collar Parameters.....	13
Collar Turning	13
Versions of Double Point Turners	15
Two Bench Top Designs	24
Experimental Evaluation	29
III. PIVOT TURNER DESIGN AND ANALYSIS.....	35
Design Specifications.....	35
C-Shaped Brackets Design	42
Drive Unit Design	47
Bridge Design.....	54
Holding The Rigid Ply	54
Turning Process	59
The Modified Drive Unit Design	62

Table of Contents (Continued)

	Page
IV. EXPERIMENTAL EVALUATION	64
System Integration	64
Automated Loading-Turning-Unloading Experiment.....	65
System Evaluation	68
V. THE CONCEPT FOR INTEGRATION OF TURNING AND PRESSING PROCESSES.....	76
Manual Pressing Operation.....	76
Concept Integration	76
Automatic Seam Alignment.....	78
VI. CONCLUSIONS AND RECOMMENDATIONS.....	85
Conclusion	85
Recommendations	86
APPENDICES	88
A. Kinematic modeling of a modified turner machine.....	89
Introduction.....	89
Drive Unit Link Parameters	91
Kinematic Modeling.....	92
Solving by TK Solver of the Kinematic Equation	101
Dynamics Modeling.....	108
Solving by TK Solver of the Dynamic Equation	114
B. Links Parameters.....	126
C. Analysis Including Definition.....	131
Variable Sheet	132
Rule Sheet	133
D. Hardware Specifications	137
E. Electrical Wiring Diagrams	138
F. Assembly Drawings	141
REFERENCES.....	150

LIST OF TABLES

Table	Page
A.1 Magnitude and Angle of Vector Locations	93
A.2 Magnitude and Angle Location of Vector r_{gi}	95
A.3 Magnitude and Angle Location of Vector r_{pi}	96
B.1 Parameters of Link 5	126
B.2 Parameter of Link 6	127
C.1 Variable sheet	132
C.2 Rule Sheet	135

LIST OF FIGURES

Figure	Page
1.1 Collar Configuration	2
2.1 Manual Turning	6
2.2 Turning and Pressing Machine	8
2.3 Turning Sequence	9
2.4 Commercially Available Machines	12
2.5 Collar style and parameters	14
2.6 Mechanical Double Point Turner	16
2.7 Tube Turner Concept	18
2.8 Tube Turning Sequence	19
2.9 Collar Turning via Circular Clipper	20
2.10 Side View of the Pivot Turner	21
2.11 Vacuum Turning Concept	23
2.12 Tube Turner Concept	26
2.13 Tube Turner Sequence	27
2.14 Bench Machine	28
2.15 Pivot Turning Concept	30
2.16 Tube Turner	32
2.17 Pivot Turner	34
3.1 Turning Sequence	36
3.2 Turning Sequence (continued)	37
3.3 Force Measurement on the Bench Machine	38
3.4 Experimental Testing of the Lunapress	40
3.5 Design of Two C-shaped Brackets.....	44
3.6 Configuration of the C-Shaped Brackets.....	46

List of Figures (Continued)

	Page
3.7 Drive Unit Design.....	48
3.8 Drive Unit Design.....	59
3.9 Design Using Timing Belt.....	50
3.10 Speed of the Steeper Motor.....	52
3.11 Assembly Drawing.....	54
3.12 Holding the Rigid Ply.....	56
3.13 Air Jet Assembly in the Turner Machine.....	58
3.14 Turning Process.....	59
3.14 Turning Process (continued).....	60
3.15 Modified Drive Unit Design.....	62
4.1 Overall Layout of the Workstation.....	66
4.2 Turning Sequence.....	69
4.3 Forces Applied on the Collar Seam.....	73
4.4 Quality of the Collar Point.....	75
5.1 Pressing Sequence.....	77
5.2 Integration of the Turning and Pressing Operation	79
5.3 Two Clamped Plates - Linear Motion.....	82
5.4 Two Clamped Plates - Pivoting Motion.....	83
5.5 Testing of the Automatic Seam Alignment.....	84
A.1 Coordinated Frame Fixed to the Links	90
A.2 Vector Location of the Right Side	92
A.3 Location of the Coordinated Frame on the C-Shape Bracket	94
A.4 Rotating Link	98
A.5 Angular Position of Links 3, 4, 5, and 6	103

List of Figures (Continued)	
A.6	Angular Velocity of Links 2, 3, and 4 104
A.7	Distance Between the Two Clippers Tips 105
A.8	Real and Imaginary Parts of Position Vector of Clipper Tip..... 106
A.9	Real and Imaginary Parts of Velocity of the Clipper Tip..... 107
A.10	Reaction Forces on Link 4 111
A.11	Reaction Forces on Link 2 111
A.12	Transformation of the Reaction Forces to Link 3 113
A.13	Reaction Forces on Link 3 113
A.14	Force Acting by the Collar During the Turning... 116
A.15	Angular Acceleration of Links 2, 3, and 4 117
A.16	Real and Imaginary Parts of Acceleration of the Clipper Tip..... 118
A.17	Driving Torque..... 119
A.18	Force Acting by Link 1 on Link 2 - f_{12x2} 120
A.19	Force Acting by Link 1 on Link 2 - f_{12y2} 121
A.20	Force Acting by Link 3 on Link 2 - f_{32x2} 122
A.21	Force Acting by Link 3 on Link 2 - f_{32y2} 123
A.22	Force Acting by Link 1 on Link 4 - f_{14y4} 124
A.23	Force Acting by Link 1 on Link 4 - f_{14x4} 125
B.1	Link 5 - Consists of Three Parts 129
B.2	Link 6 - Consists of Two Parts 130
E.1	Turning Machine Stepper Motor Drive Circuit..... 142
E.2	Pneumatic Valve Drive Circuit..... 143

List of Figures (Continued)

	Page
F.1 Pivot Turner in 3-D.....	145
F.2 Cross Section of the Pivot Turner.....	146
F.3 Cross Section of the Drive Unit.....	147
F.4 Front View Showing the Rotary Actuator.....	148
F.5 C-Shape Bracket Assembly.....	149

CHAPTER I

INTRODUCTION

Background

Apparel manufacturing operations are investigated to improve productivity and increase competitiveness with rising foreign manufacturers, from Japan and Western Europe. The process of shirt manufacturing is currently done through a series of semi-automated operator assisted operations. This project concerns shirt collar turning, with the intention of automating the operation to achieve a consistent and high quality product.

Productivity in the apparel industry can be significantly improved through automation. Until recent years, the advance of automation in the apparel industry has been blocked by high capital requirements and technological limitations. Recent technological advances in such technologic as Computer-Aided Design (CAD) Computer-Aided Manufacturing (CAM) have contributed to the development of apparel automation.

The shirt collar consists of two plies which are sewn together along three sides as shown in Figure 1.1 (a). One of the plies has a fused lining for stiffening. After stitching the collar around the three sides, two corners or "collar points" are formed as shown in Figure 1.1 (a). The two plies comprise an inner "collar pocket" and it is necessary to conceal the stitched seam edge. Therefore, the collar must next be inverted inside-out, or "turned" as shown

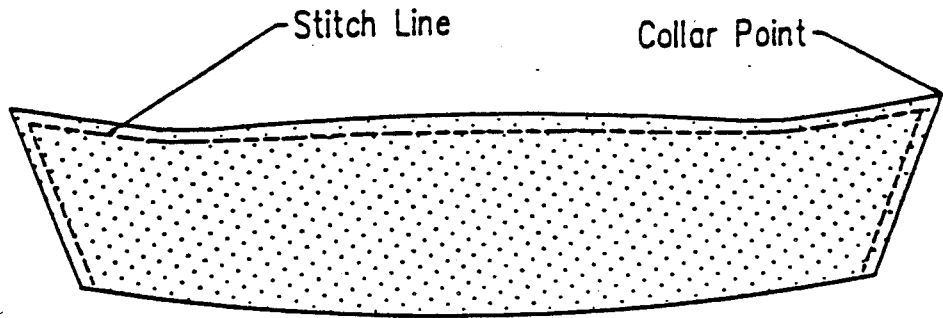

(a): Unturned Collar

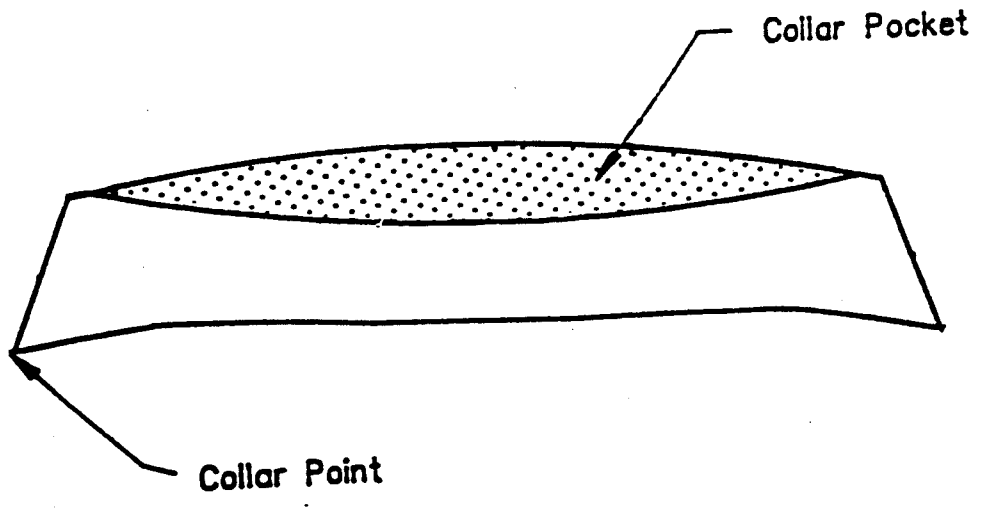

(b): Turned Collar

Figure 1.1: Collar Configuration

in Figure 1.1 (b). The collar must be pressed after the turning process is complete to obtain sharp collar points.

Purpose

The purpose of this project report is to discuss the design, development, and demonstration of a system for automated collar turning. This project concerns the development and design of a double point collar turning machine which can significantly improve the ability to automate the manufacture of shirt collars. No available device or machine exists that can accomplish double point collar turning.

Objectives

The research for this project is aimed at designing, developing, and demonstrating a proof-of-concept device for double point shirt collar turning. The double point turning concept is integrated with an automated handling system to demonstrate the feasibility of loading and unloading the collar from the turning device.

Research Tasks

Achieving these research objectives requires several tasks. The first task involves analyzing existing shirt collar manual turning operations and examining commercially available turning and pressing machines. The development of general concepts for automating double point collar turning precedes the development of an automated machine for turning, and followed by kinematic modeling of the turner machine.

Project Organization

The operation of the manual collar turning device known as the Lunapress is discussed in Chapter II. Presenting historical development of collar turning in the last four decades, Chapter II also reviews commercially available turning and pressing machines and discusses concepts for double point collar turning. A "Pivot Turner", capable of turning both collar points simultaneously is discussed in Chapter III. Chapter IV Presents an experimental evaluation of the prototype pivot turner. The turning and the pressing concept is integrated into a single machine as discussed in Chapter V. Finally, the conclusion and the recommendations of this work are presented in Chapter VI.

CHAPTER II
METHODS FOR COLLAR TURNING

History of Collar Turning and Pressing

The history presented describes the last four decades in the development of collar manufacturing since the sources consulted consist of personal interviews with individuals having nearly forty years in the shirt industry and the available literature. Early collar manufacturing was accomplished using a manual process. A manual turner shown in Figure 2.1 (a) consisted of two conical rods, between which the collar point was trapped and used to turn the collar. The collar was turned inside out by pulling the collar against the stationary conical rod. Only the corner of the collar with the collar point was pressed in a die press to produce a sharp point. The final press was done with a hand steam iron.

About twenty years ago Amco Autopress developed an automatic air-operated turning system in which the turner traps the collar point by using an air cylinder rather than a manual clamp as shown in Figure 2.1 (b). Later, the invention by Amco Autopress, of a turning and pressing machine, brought reductions in production time since simultaneously a collar point was being pressed while the operator turned a second point and prepared it for pressing.

(a): Manual Turning

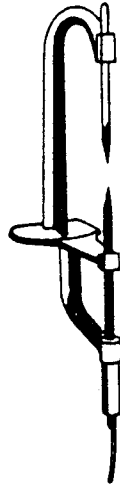

(b): AMCO Air-Operated

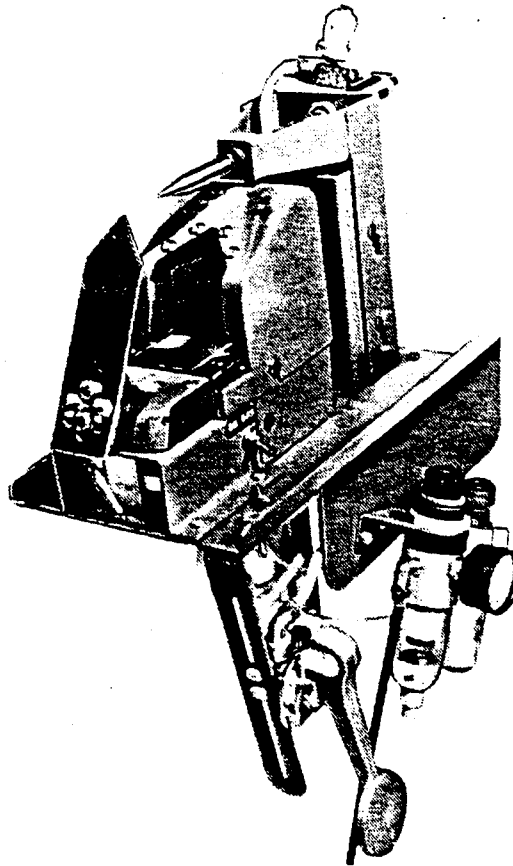

Figure 2.1: Manual Turning

Figure 2.2 (a) shows two clippers and turners located below the pressing die. Initially the operator turns one side of the collar and lays the collar on the pressing die. The operator actuates the right template so it is moved into the die block for the pressing procedure. As the pressing is done the operator turns the next (left) collar side following the same pressing procedures. Literature on the Amco Autopress [2] explains that over 300 dozen of shirt collars per work day can be turned and pressed on a single machine. However, this operation was said to be the most complicated in the apparel industry. Eventually Luna Industrial Co. designed a new machine, known as the Lunapress, to simplify the operation.

Fifteen years ago the Lunapress machine had undergone changes to meet market demands. This resulted in the machine version shown in Figure 2.2 (b). A human operator performs both turning and pressing of the two collar points sequentially in this type machine.

Evaluation of Manual Turning on the Lunapress

Collar turning is now accomplished manually, turning the two collar points in sequence. One version of manual single point turning is done through the use of the Lunapress. The operation of inverting the collar, termed "turning", folds and conceals the stitch line inside the collar pocket. After the turning process is complete, the collar points are "pressed" to obtain sharp collar points.

(a): AMCO Autopress II [1]

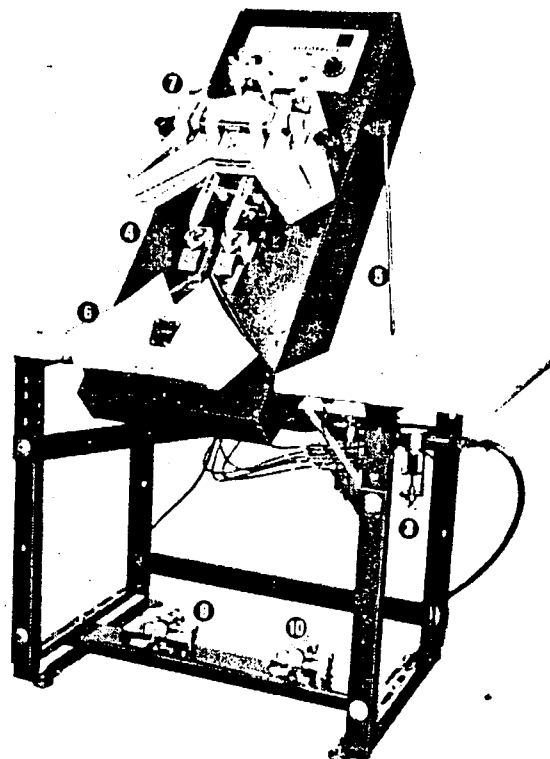

(B): Lunapress Machine

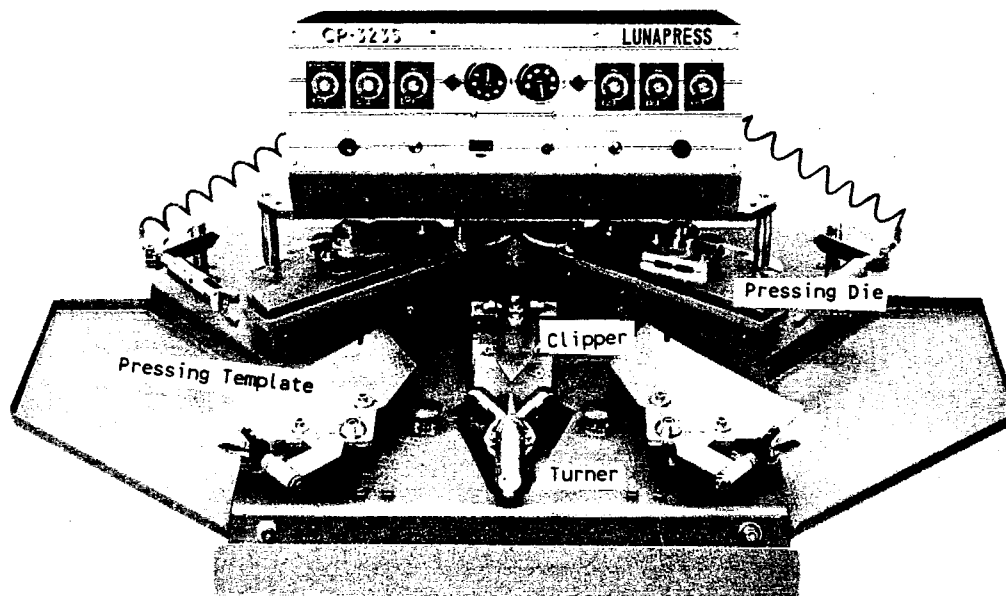
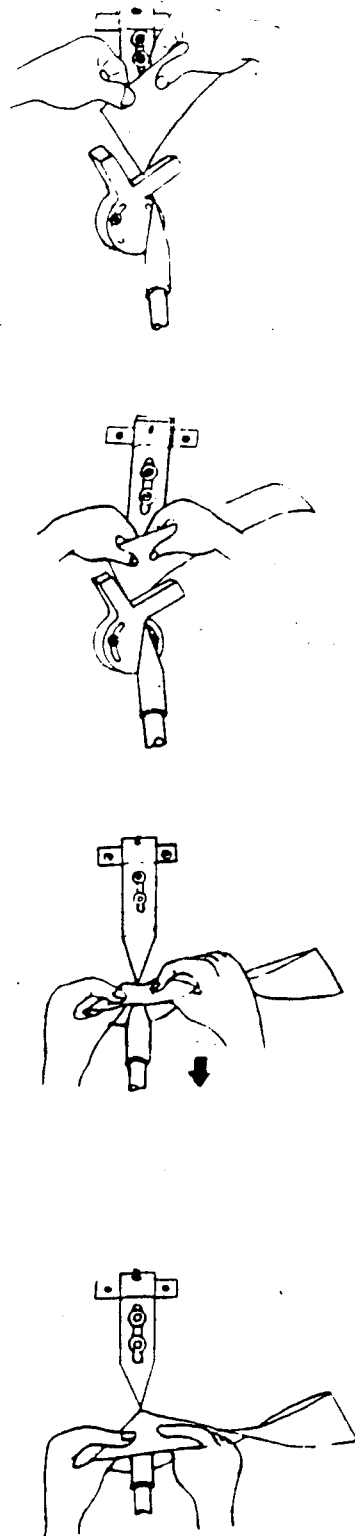

Figure 2.2: Turning and Pressing Machine



Sequence

Figure 2.3: Turning Sequence

The evaluation of manual turning on the Lunapress machine is useful for planning the automatic double point turning operation, used to invert both collar points simultaneously. The turning component of the machine consists of a "clipper" and a "turner" as shown in Figure 2.2 (b). The clipper is a stationary, flat triangular blade which points towards the operator. The turner is a conical component attached to the end of a pneumatic cylinder. The cylinder when actuated forces the turner tip against that of the clipper.

Manual shirt collar turning is done by inverting the collar points in sequence. The operation begins when the operator loads the collar onto the clipper, as shown in Figure 2.3 (a). Next, in the trim operation the operator presses down the clippers into the trim stations as shown in Figure 2.3 (b). In the third operation the turner is actuated to trap the collar point against the clipper. After this step is completed, the operator pulls the collar to maneuver the collar point as depicted in Figure 2.3 (c). Finally in Figure 2.3 (d) the operator pulls and releases the collar three to four times to ensure good quality of collar point. In this operation the operator squeezes the extra materials left after the trim was done into the cone point. The operator repeats this procedure for the second collar point.

Commercially Available Turning and Pressing Machines

Identification of other commercially available manual turning and pressing machines was conducted by attending the 1989 Bobbin Show in Atlanta. Several different machines are shown in the following Figures. These machines are all similar to the Lunapress design. A major difference lies in the configuration of the clippers and the turners. The major differences can be categorized as follows:

Clipper size:

The size of the clippers and turners in the Lunapress are significantly larger than that of other machines (Figure 2.4 (a)).

Turner cone:

The conic angle of the tip of the turner differs among the machines (Figure 2.4 (b)).

Pressing stations size:

Different size of air cylinders were selected for each design (Figures 2.4 and 2.2).

These turning and pressing machines were made by using the same concepts as the Lunapress design, with no attention given to process automation. No attempt was made to design a manual machine to turn both points simultaneously or press the two points simultaneously.

(a): Bitmato

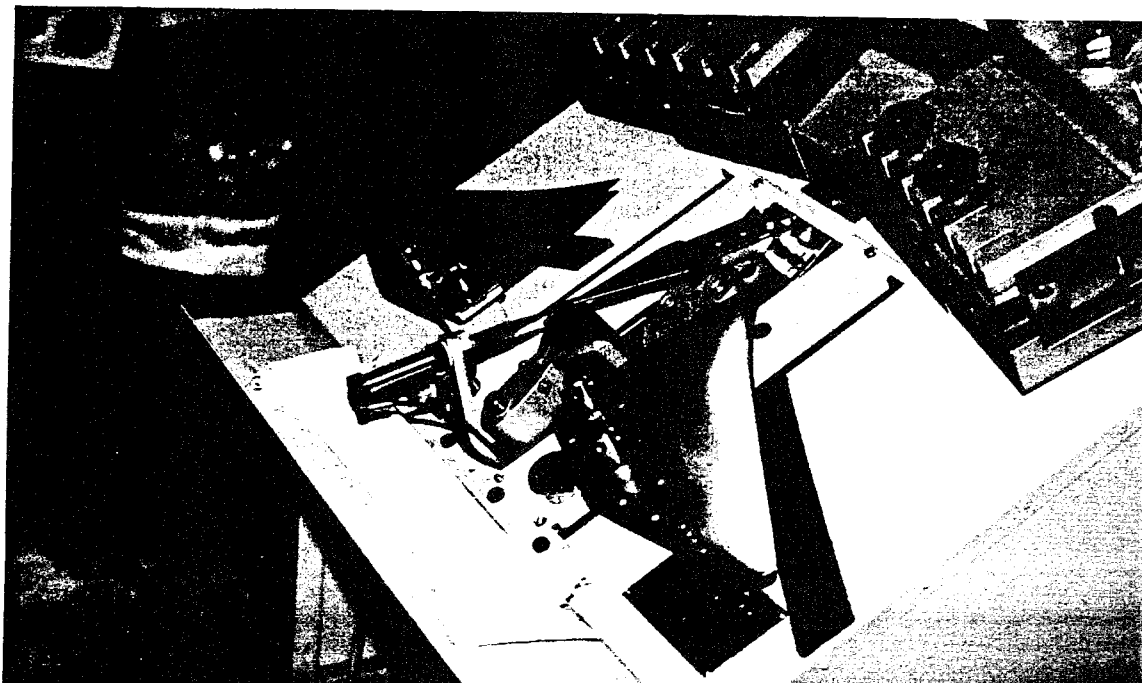

(b): Tech Style

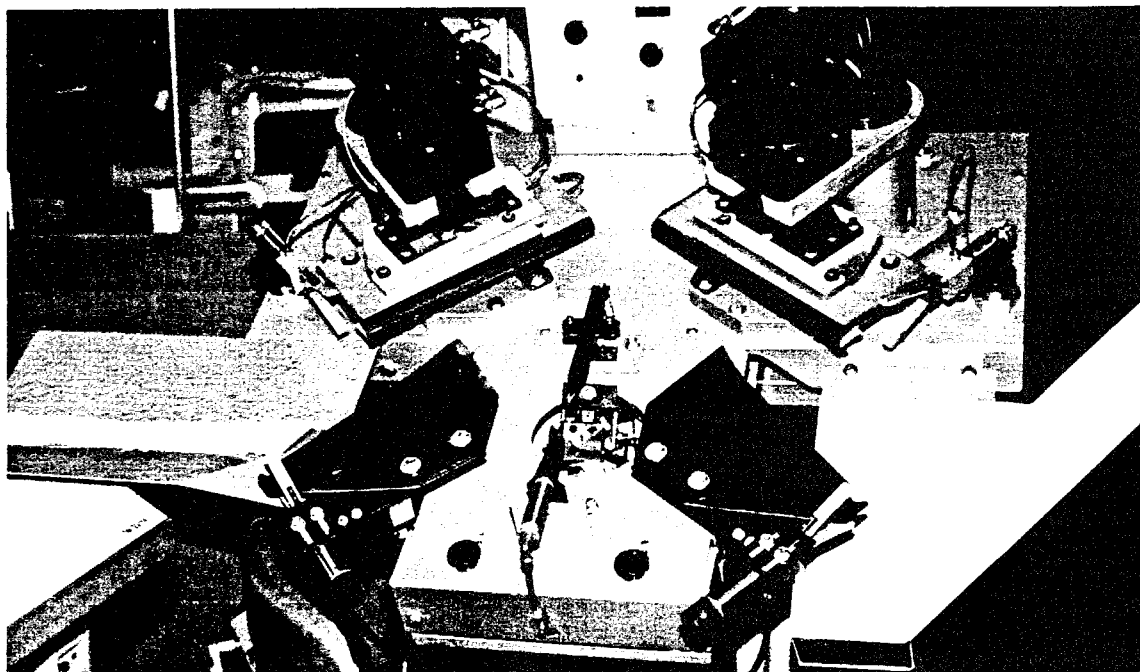

Figure 2.4: Commercially Available Machines

Collar Parameters

Collar Size and Style

Conventional collar sizes vary from 14.5 to 17.5 inches in the shirt manufacturing industry, and are measures of the human neck size. This project considers only the 15.5 inch collar size and the collar style shown in Figure 2.5. The following parameters of collar style represent the collar and head angles:

Lc - the distance between the two collar points

Ch - head angle

Cc - collar angle in military style

Collar Turning

Existing commercial collar turning machines are designed to allow human operators to turn a single collar point at a time. The machines are designed to perform single point collar turning, where the same machine components are used to turn each of the two collar points at different times.

Double point collar turning implies the simultaneous turning of both collar points with a single device. At present, no commercially available device exists that can do double point collar turning. For that reason, various concepts for double point collar turning have been developed. The decision to not development a single collar point turning machine was justified since it was obvious that with double point turning the turning cycle can be significantly reduced.

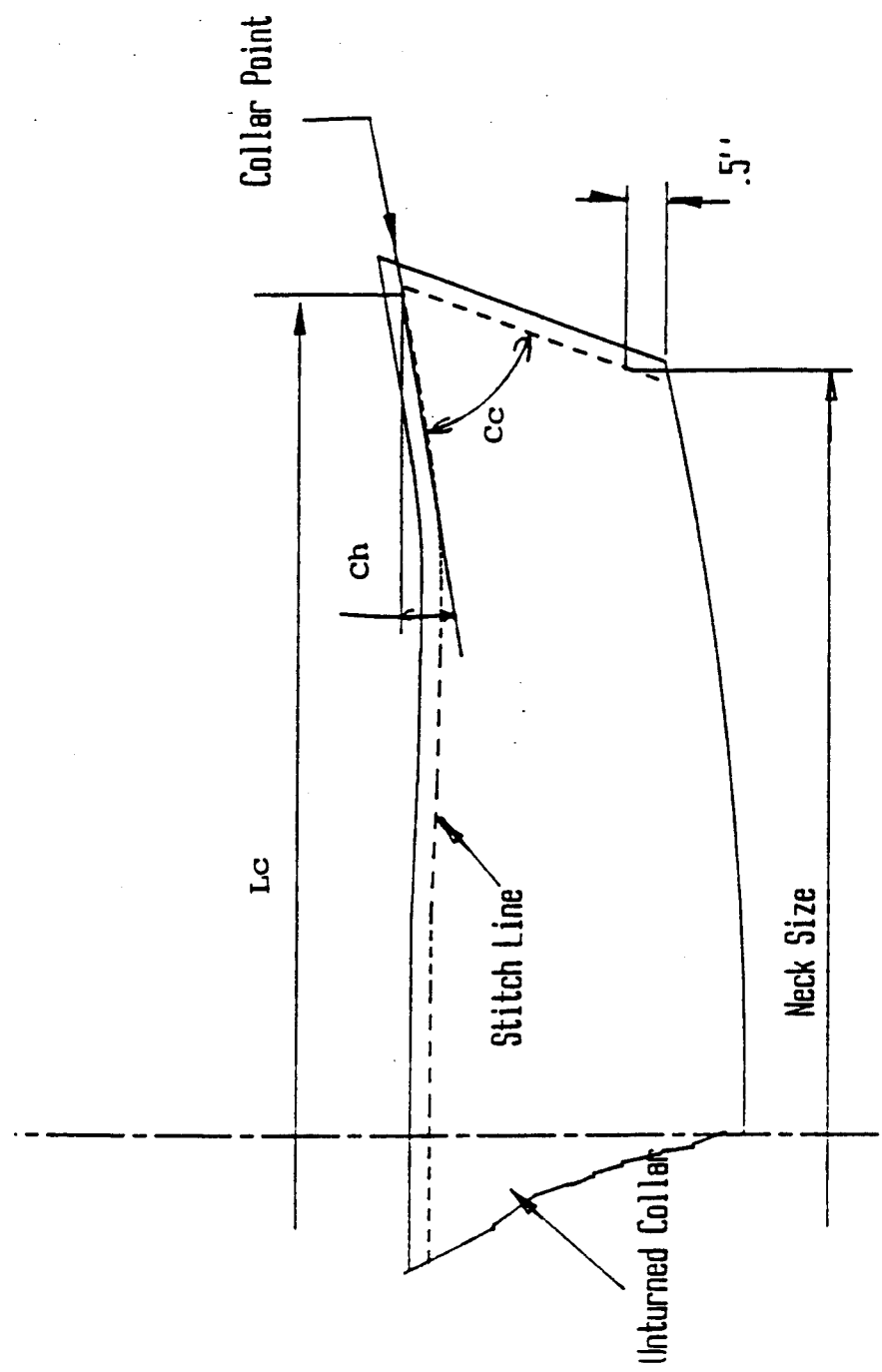

Figure 2.5: Collar style and parameters

Versions of Double Point Turners

Concept I: Mechanical Double-Point Turner (MDPT)

The proposed Mechanical Double Point Turner consists of two pairs of clippers and turners similar identical to that of the Lunapress. The clippers and turners are rigidly attached to a rectangular frame (labeled the inner frame) and are located about 10"-12" apart as shown in Figure 2.6. The axes of the two clipper and turner pairs are oriented parallel with one another in a vertical configuration. The distance between the two clippers should be large enough to secure both points of a single collar over them without causing excessive stretching of the collar workpiece attached between the clippers.

Figure 2.6 (a) illustrates the placement of the collar point over the clippers. Once the second collar point is positioned on the clipper (Figure 2.6 (b)), two pneumatic clamps connect the collar to the inner frame. The double point collar turning begins with the slow retraction of the pneumatic actuator mounted to the base of the outer frame (Figure 2.6 (c)). This action forces the inner frame and all the connected linkages in a linear motion. As both collar points are moved down away from the collar end, the collar workpiece turned inside out. Figure 2.6 (d) illustrates the final position of the turned collar.

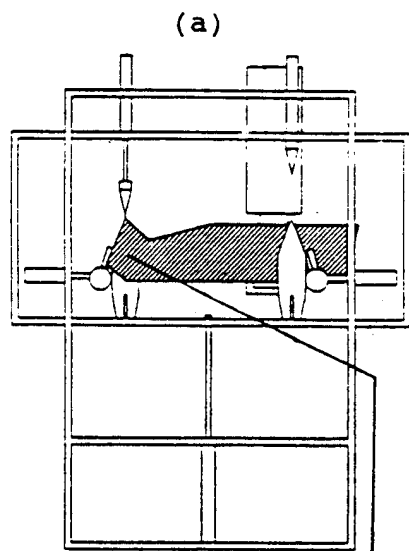

Collar Point Over First Clipper

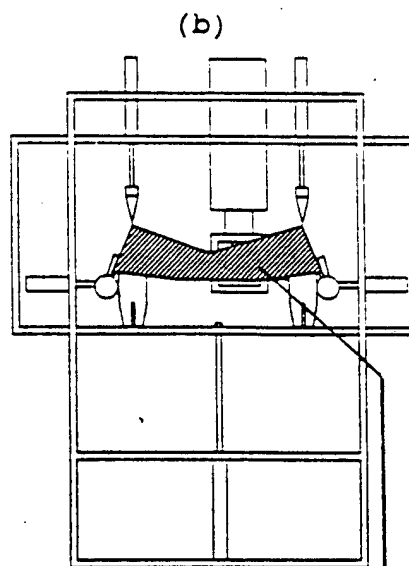

Collar Points Over Both Clippers

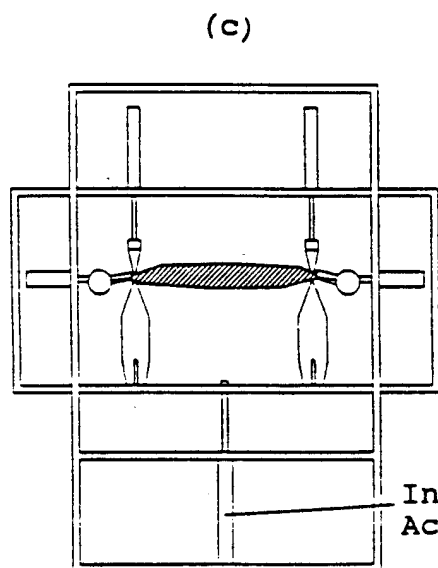

Inner Frame Actuator

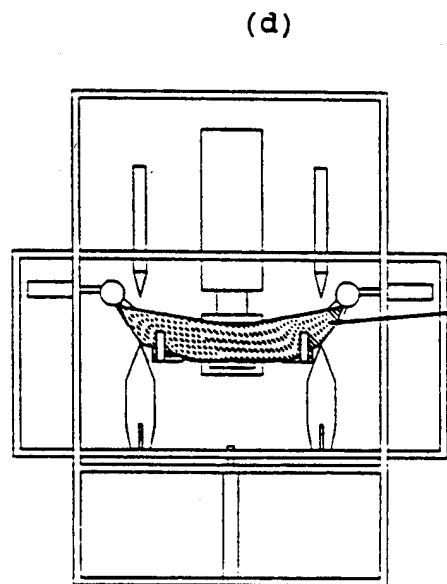

Turned Collar

Figure 2.6: Mechanical Double Point Turner

Concept II: Tube Turner [TT]

Epaulets for mens' shirts are turned on a device which incorporates a long tube with a long pointed rod attached to a manually-operated handle as shown in Figure 2.7 (a). An unturned epaulet (each epaulet has only one point) is slipped over the tube's end and then pushed through the tube by the pointed rod. The inverted epaulet is subsequently pushed out the bottom of the tube. This idea was used in the development of the tube turner shown in Figure 2.7 (b). The operation of this device would be similar to that of the MDPT.

The operation of the tube turner following this step is sequenced by the illustrations in Figure 2.8. The turners are actuated downward until they come in contact with the tips of the clippers trapping the collar points just as on the Lunapress. The turners and clippers are then forced through the tubes pulling the collar points down with them. The tubes invert both collar points as the turners force them deeper into the tubes. The right side of the left tube and the left side of the right tube are slotted to permit the turned collar to move through the tubes. These slots prevent excessive "bundling up" of the collar material which would form in the middle as its points move into the tubes.

Concept III: Pivot Turner [PT]

Pivot turning is intended to support the moving of the clipper and turner pair in a circular arc about a pivot point located beyond the collar area. A graphical illustration of this type of motion is depicted in the two sequential draw-

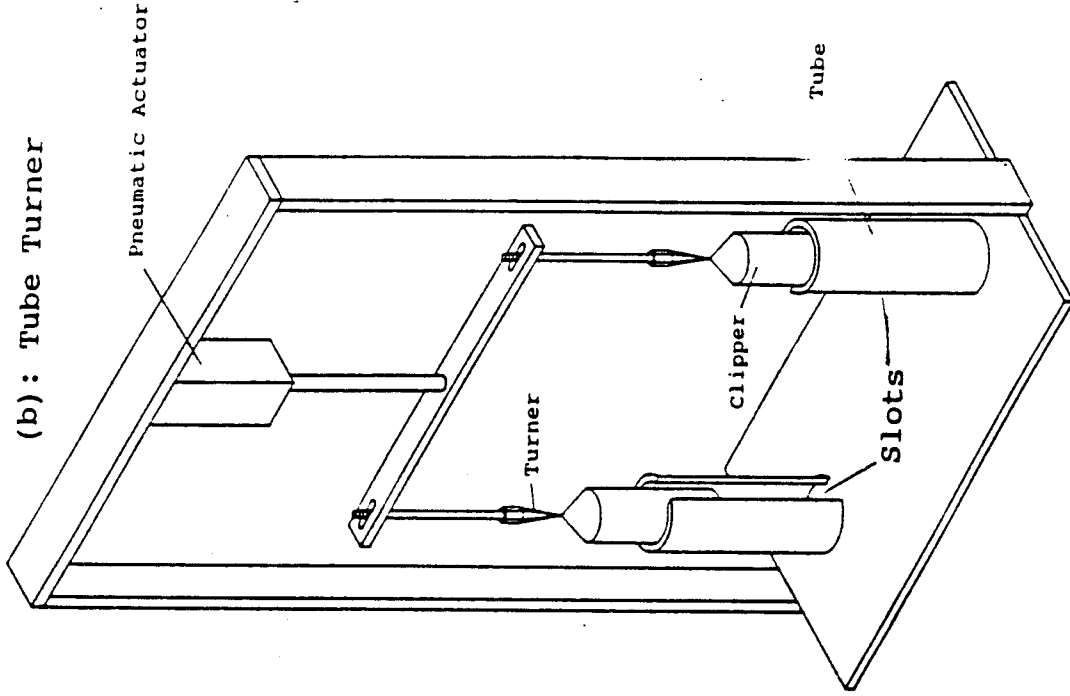

(b): Tube Turner

(a): Belt Turner [2]

**AIR OPERATED
AUTOMATIC
BELT TURNER**

Comes with $\frac{5}{8}$ ", $\frac{1}{4}$ " and 1" tubes. Can turn belts of any length. Open end, closed end and center openings.

■ T37278 \$ 350.00/ea

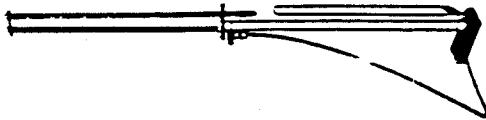

Figure 2.7: Tube Turner Concept

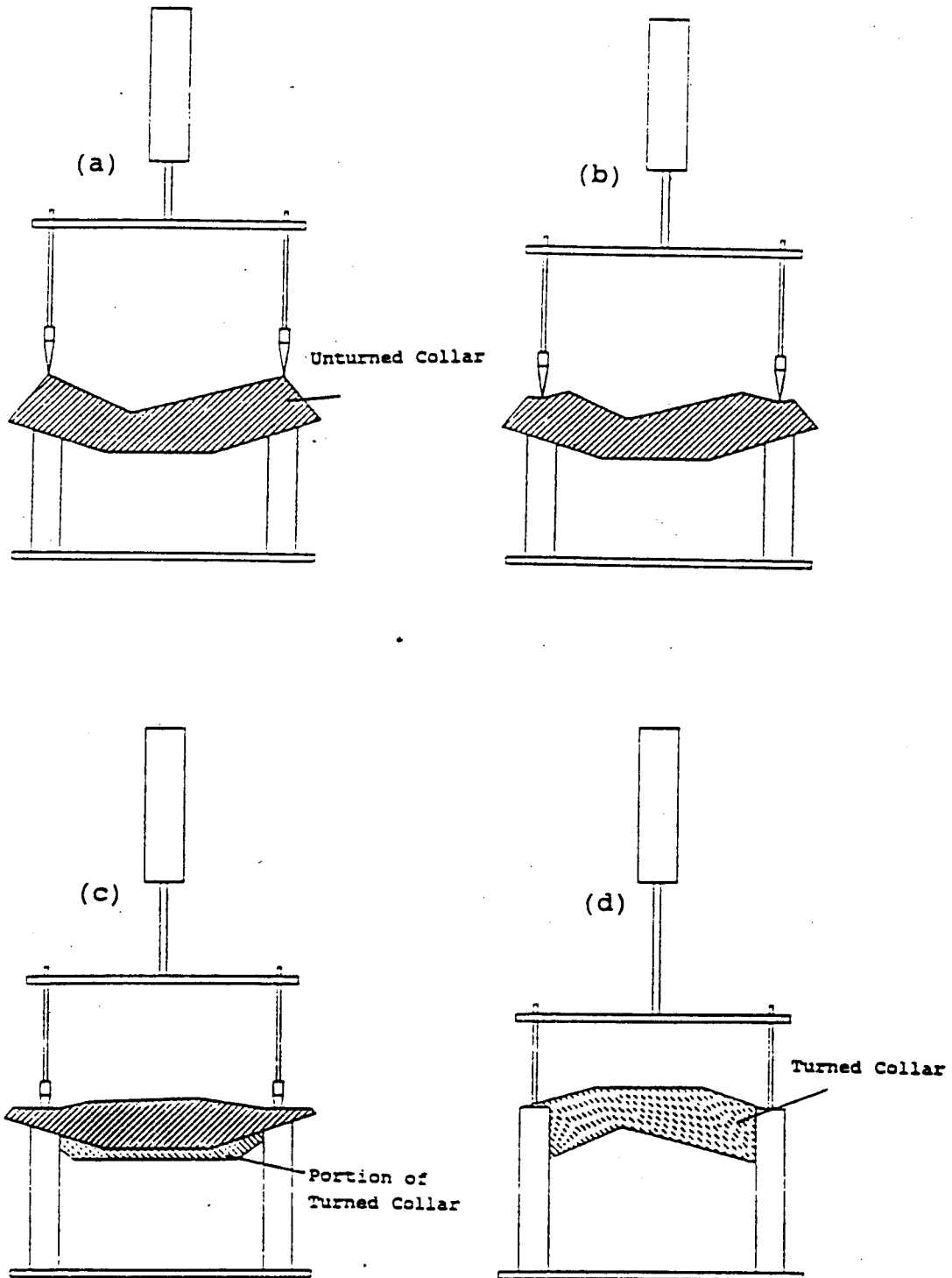

Figure 2.8: Tube Turning Sequence

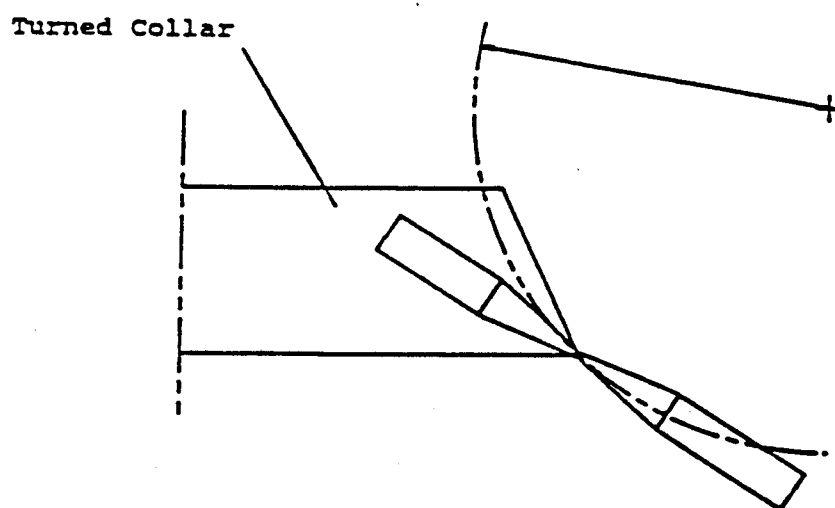
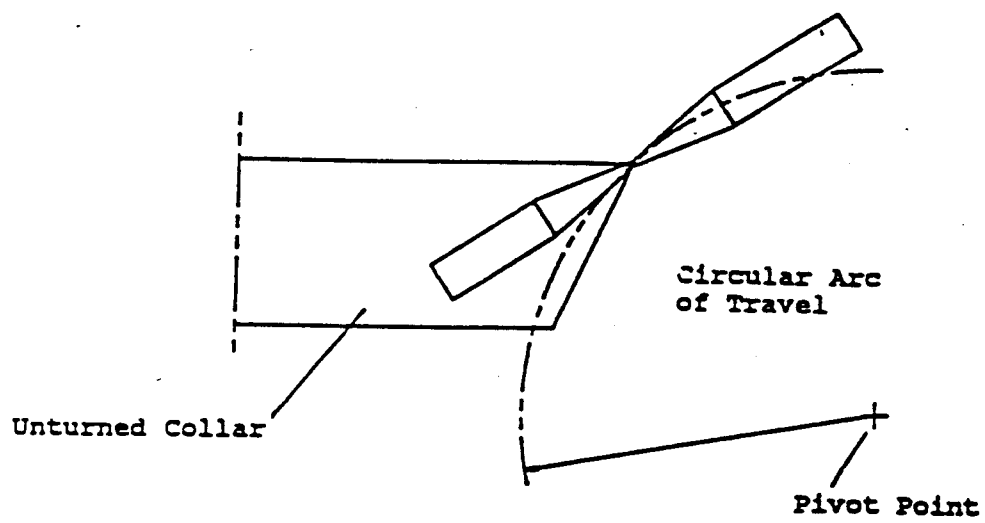

Figure 2.9: Collar Turning via Circular Clipper

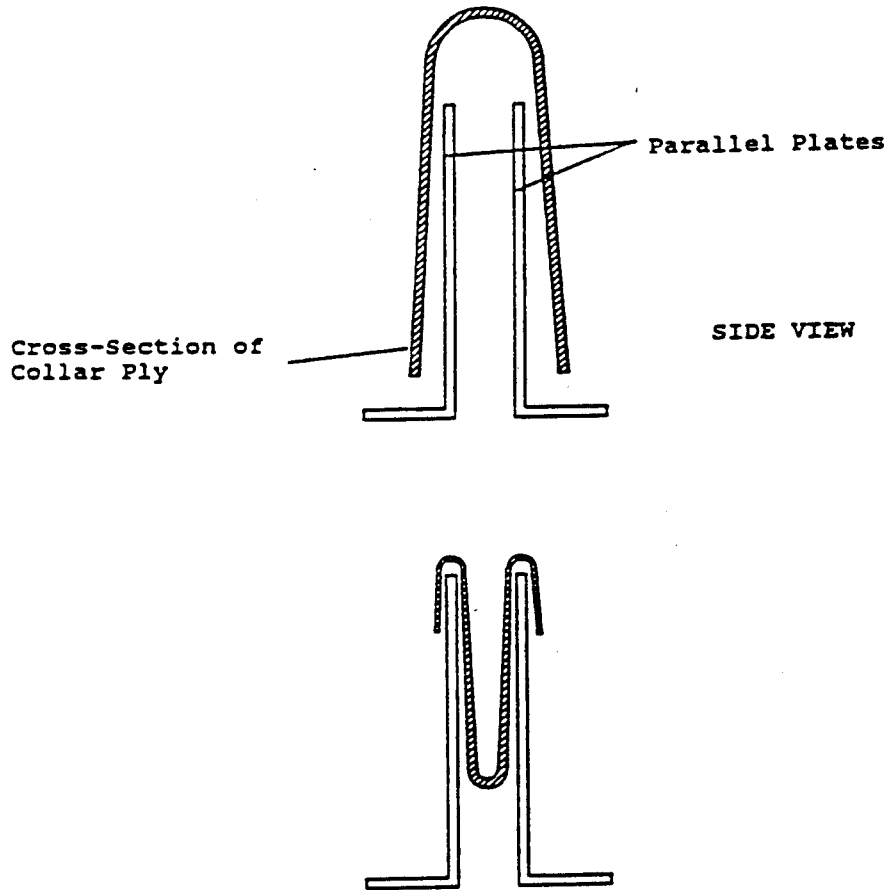

Figure 2.10: Side View of the Pivot Turner

ings in Figure 2.9. Two parallel plates support the collar and assist in its turning. Figure 2.10 demonstrates how these two stationary plates affect the orientation of the collar plies, following the transfer of the collar points through the opening between the plates. To achieve double point turning, it is required that both collar points are pivoted simultaneously.

Concept IV: Vacuum Turning [VT]

The pivot turner presented utilizes a turner to hold the collar point. It was intended to use only the two clippers and hold the collar point by vacuum in early design stages. The idea presented here does not use a turner, as is shown in Figure 2.11. The mechanism consists of two pipes and two small clipper devices. The pipes are connected to a vacuum source, and the clippers are connected by two springs to the center of the pipe. The two pipes rotate around the pivots in opposite directions. This idea is conceptually similar in operation to the pivot turning. In this method, point location is done by turning the two pipes in opposite directions. The point is held by a vacuum force and thus the need for turners is eliminated. The weakest point of this mechanism is the quality of the turned collar point, since the turner is not used in this process.

Experiments were carried out using a Dayton 'Speedaire' vacuum pump to evaluate this vacuum concept. A suction pressure of up to 10 inches of mercury was used to pull the collar point into the turning tube. The process starts with

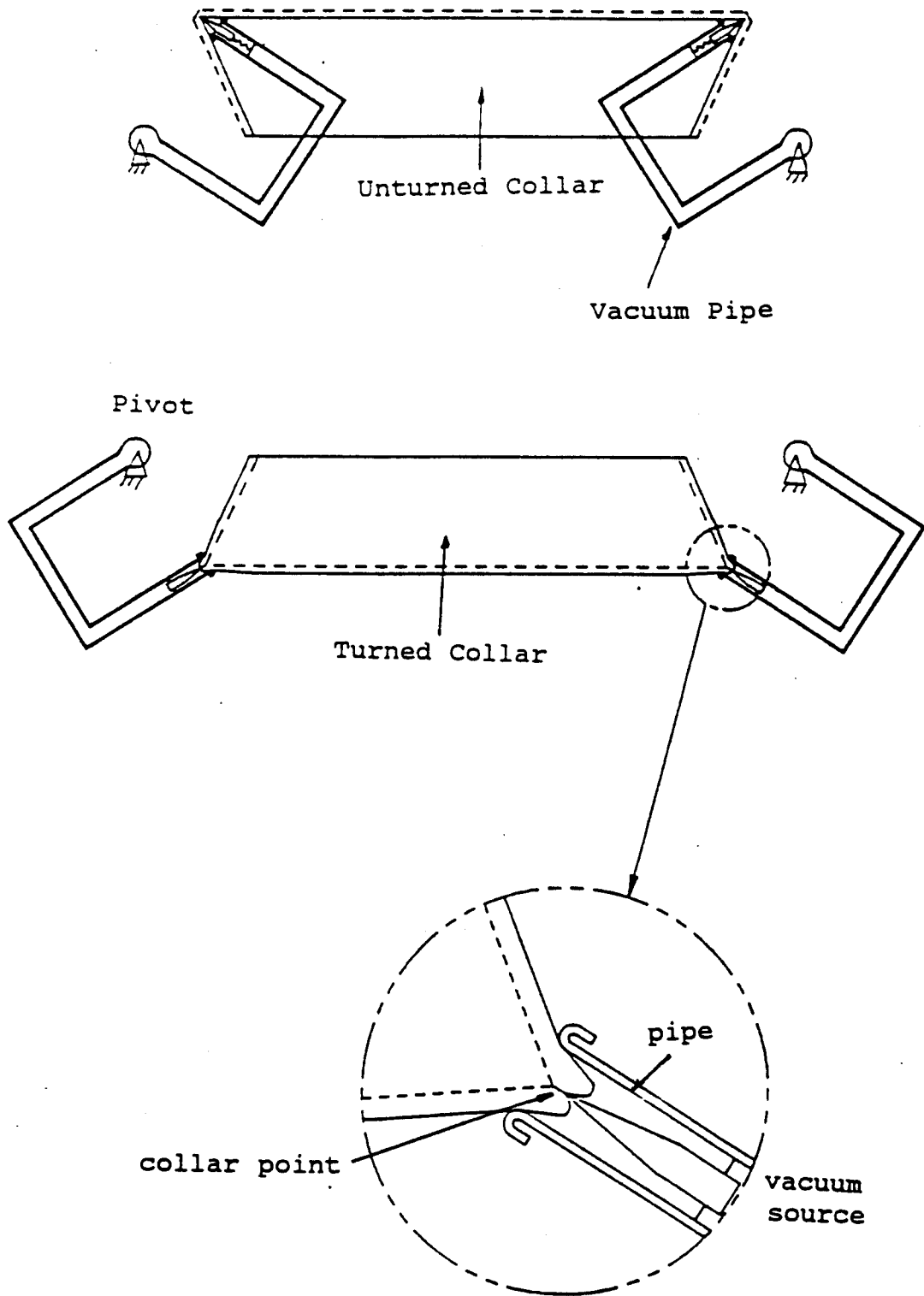

Figure 2.11: Vacuum Turning Concept

placement of the collar points over the tube extending from the discharge assembly. As the vacuum is created the collar is immediately sucked into the tube. Collar turning was performed on collars with and without the fused plastic stay. The results showed that collars without the stays turned more easily than those with the plastic stays. This is to be expected because of the additional resistance offered by the stays.

The result of the experiment, shown in the exploded view of Figure 2.11, illustrates that the quality of the turned collar point is not satisfactory. The following conclusions were derived from the results of the experiments:

1. The concept of a vacuum turning mechanism that was presented has the capability of turning the collar without the turner.
2. The quality of the turned collar point is not satisfactory.

Two Bench Top Designs

Introduction

The possibility to test two different ideas with the most probability to reach this project's objectives, was the basis for this design decision. Two bench-machines, one being the Tube Turner (TT) and the other the pivot turner (PT) were designed. Although the concept of the vacuum turner has been experimentally tested and the result of the experiment verified that it is feasible to turn the collar by using the vacuum turner concept, the quality of the turned

collar point was unsatisfactory. Therefore the idea was rejected.

Tube Turner

A bench model tube turner device has been designed and is shown in Figure 2.12. The design uses two pneumatic actuators which force the point of the turner against the tip of the adjacent clipper (in the same manner as on the Lunapress) to trap the collar point on the clipper. The axes of the two clipper pairs are oriented in a vertical configuration. Locating of the collar as well as unloading the turned collar was done manually as shown in Figure 2.13. The clipper is the cone-shaped component which slides within each of the rectangular tubes. The two tubes are actuated by the motion of the inner frame manually with respect to the external rigid structure. This motion forces the two tubes against the collar, inverting both collar points as the turners move deeper into the tubes.

Pivot Turner

A bench model double point pivot collar turning device has been designed and is shown in Figure 2.14. Two large C-shaped brackets were designed to hold the clipper and turner and to swivel in opposite directions about two pivot rods. Each turner component is held to its bracket by small machine screws; this arrangement allows the turner to be moved away from the tip of the clipper so that a collar point can be loaded between the turner and clipper. Two parallel plates

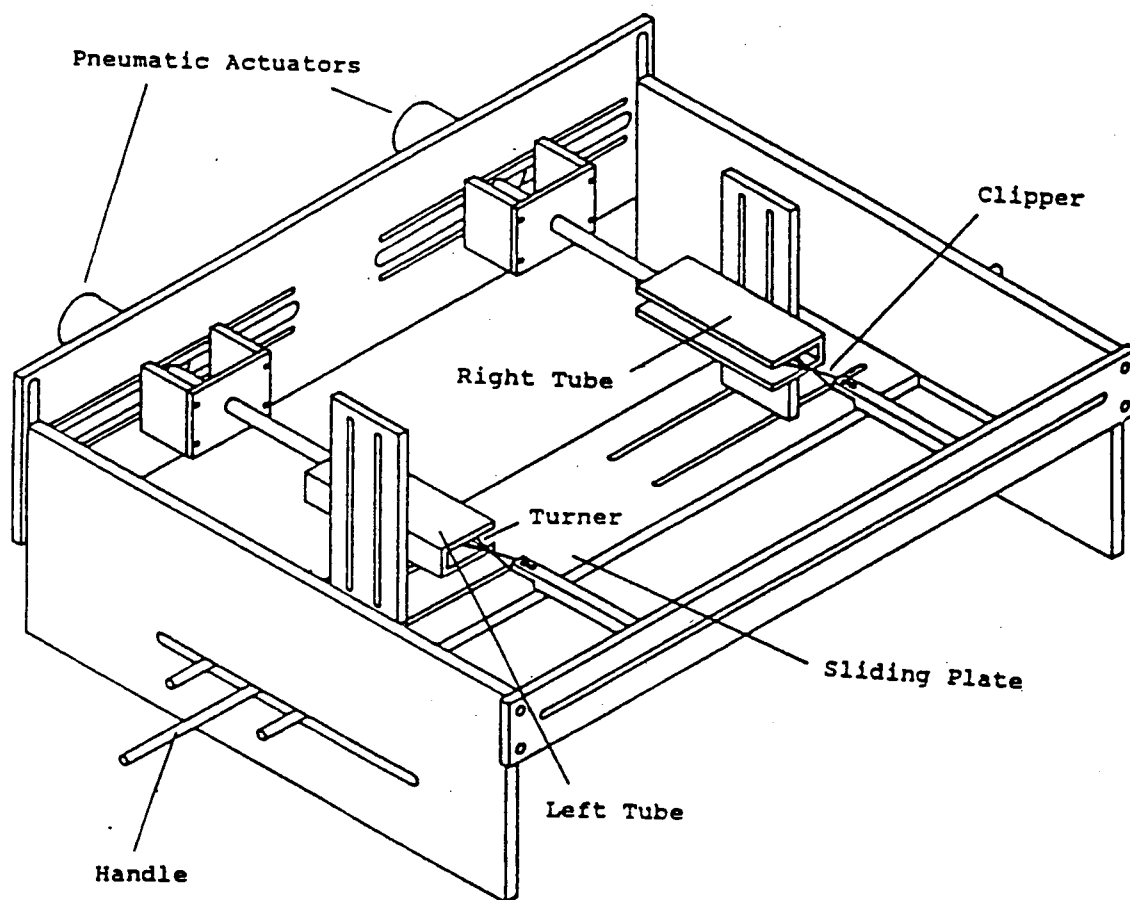

Figure 2.12: Tube Turner Concept

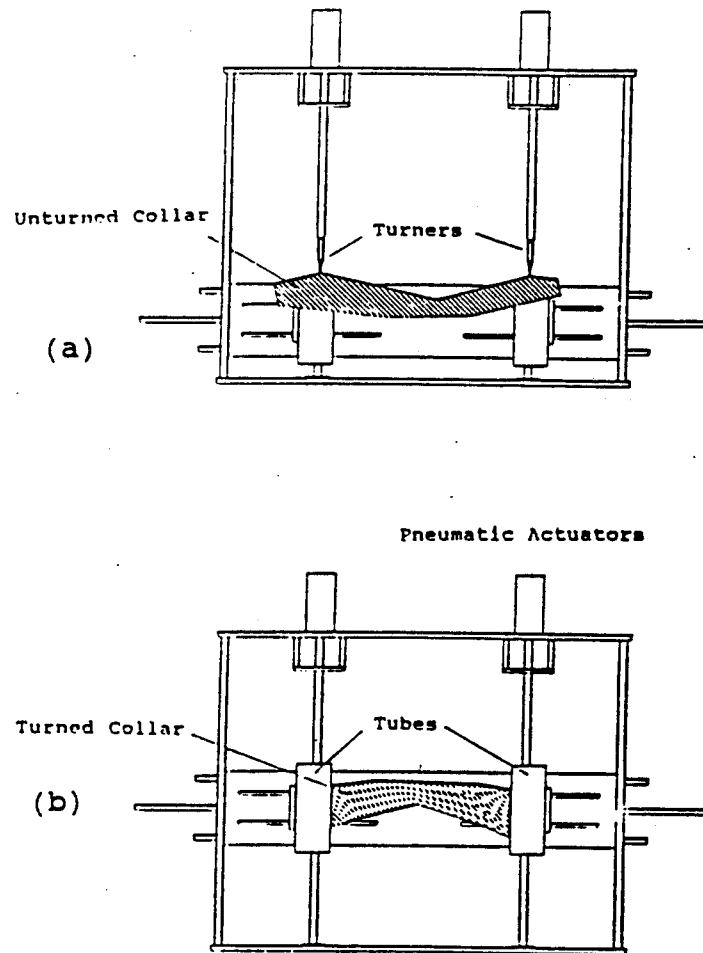

Figure 2.13: Tube Turner Sequence

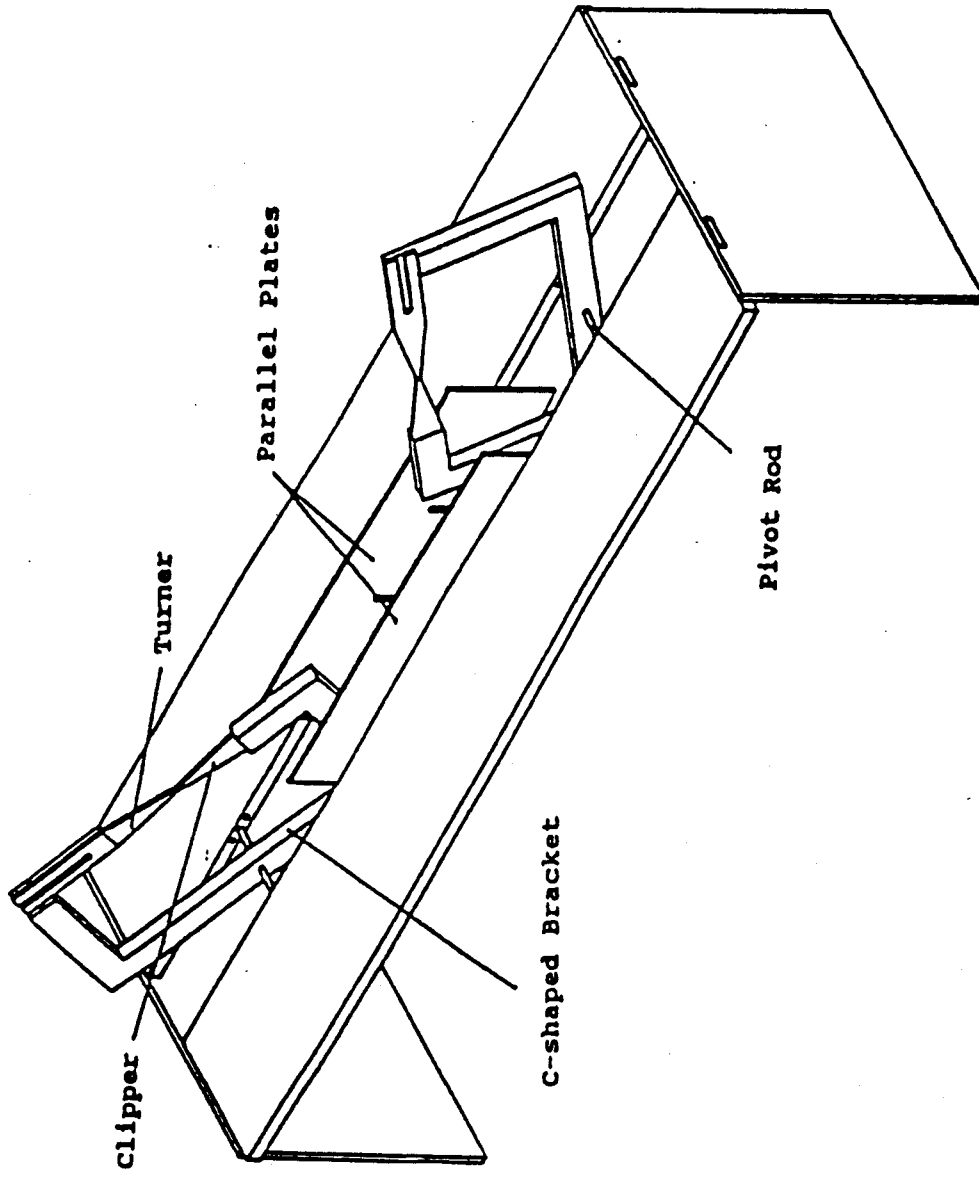

Figure 2.14: Bench Machine

guide the collar orientation of the collar plies through the slot opening between the plates.

The bench machine pivot turning device is loaded and operated manually. Figures 2.15 (a) through (c) include a sequence of illustrations depicting the front view of the device as it undergoes a collar turning sequence. Initially, the turners on the C-shaped brackets are retracted. This implies that the two clipper axes are in vertical orientation. The purpose of this procedure is to have the collar points inserted over the clippers and the two parallel plates. Once the collar is placed in the proper position, the turners can be pushed against the clippers and fastened to the brackets. Double-point collar turning is accomplished by rotating the right bracket in a counterclockwise motion and the left bracket in a clockwise motion. These rotations take place until the seam running between the collar points is taut between the tips of the two turners. The collar is inverted at this point and can be removed by loosening the clippers from their brackets.

Experimental Evaluation

Two benefits from double point turning are:

1. The operation is simplified because the collar is positioned on the turning device(s) only once.
2. The time required to turn the collar is reduced by at least half since both points are turned simultaneously.

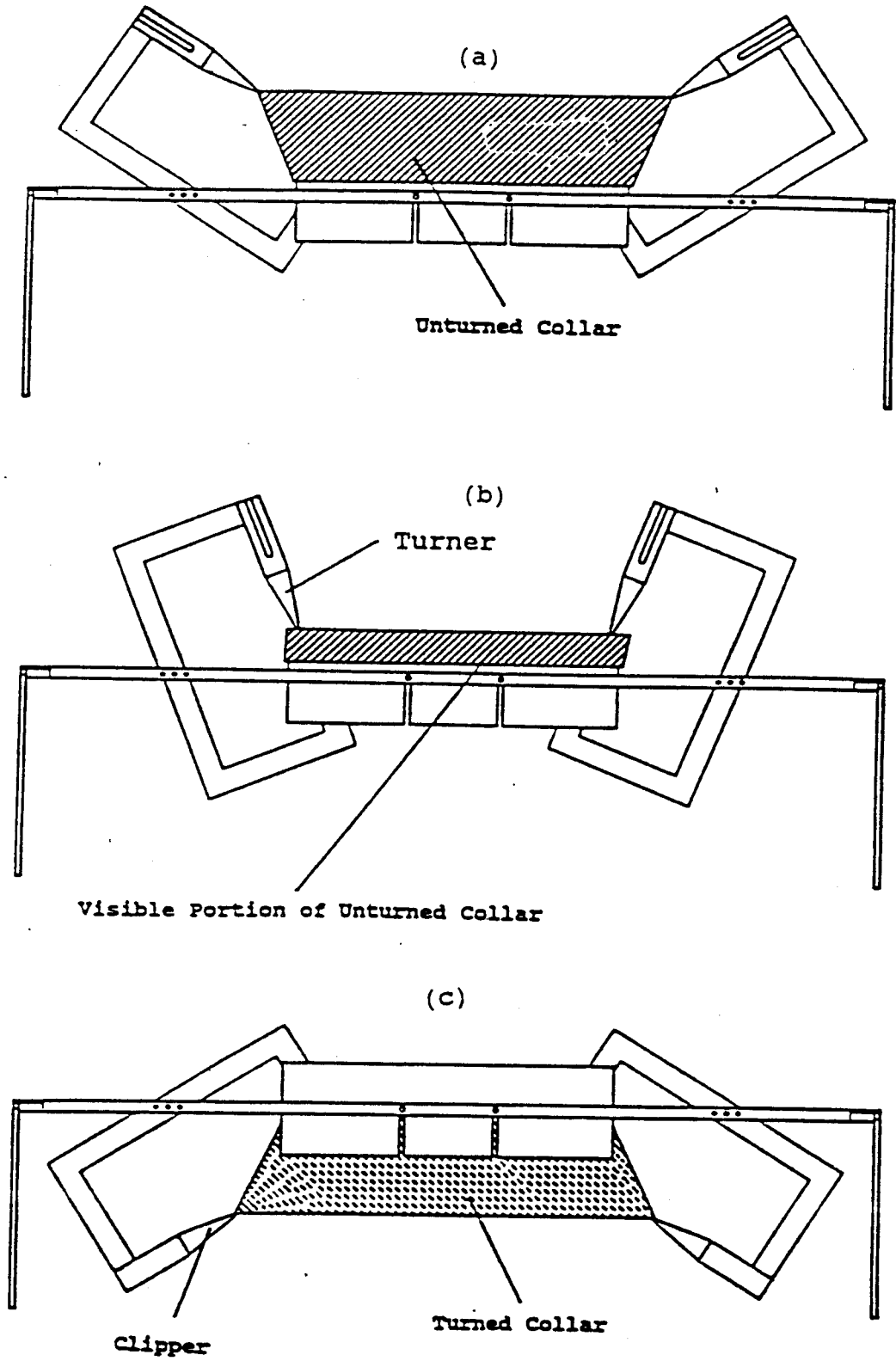

Figure 2.15: Pivot Turning Concept

The concept of double point collar turning must address the issue of the collar point quality. This implies that the machine must have the capability to apply force on the collar points after the turning process is complete. The Pivot Turner bench machine addresses this issue since the collar points are trapped between the turners and clippers, and it is possible to apply force on the collar after the turning operation since the two C-Shaped Brackets swivel in opposite directions.

Tube Turner

The Tube Turner bench machine was experimentally tested and the result of the experiment showed that it is possible to turn the collar by using the tube concept. The result of the turning experiment shown in Figure 2.16, illustrates that the quality of the turned collar point is not satisfactory because the machine was not capable of applying force on the collar points after the process was complete.

Pivot Turner

Experiments were conducted on the bench machine and the concept was verified to work satisfactorily. The collar points were placed on the clipper tips and the turners pushed against the clippers to hold the point during the turning. The turning operation was done by manual rotation of the C-shaped brackets in opposite directions. The collar can be removed by loosening the clippers from their brackets and by manually pulling the inverted collar downward apart from the

(a): Locating the Collar Points

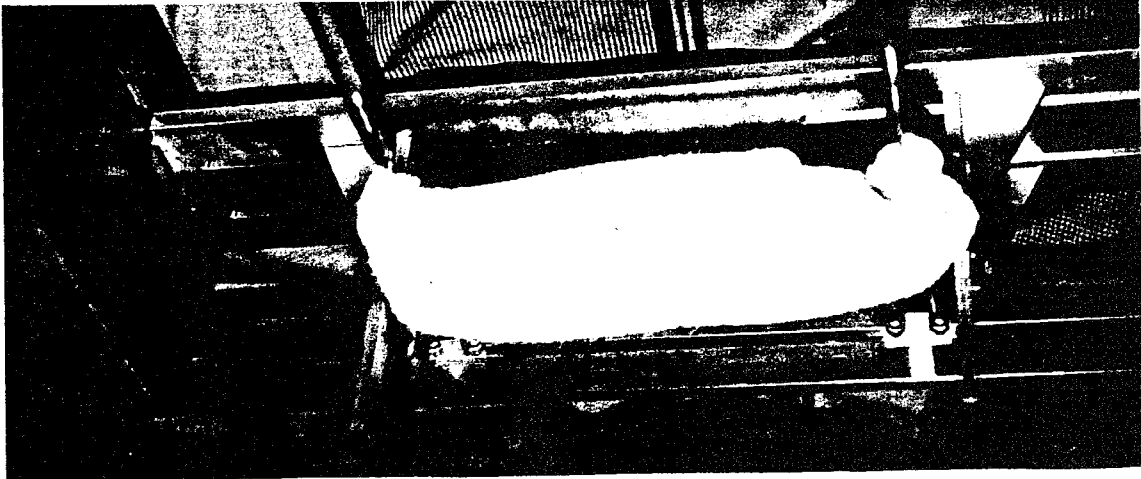

(b): Turning the collar Points

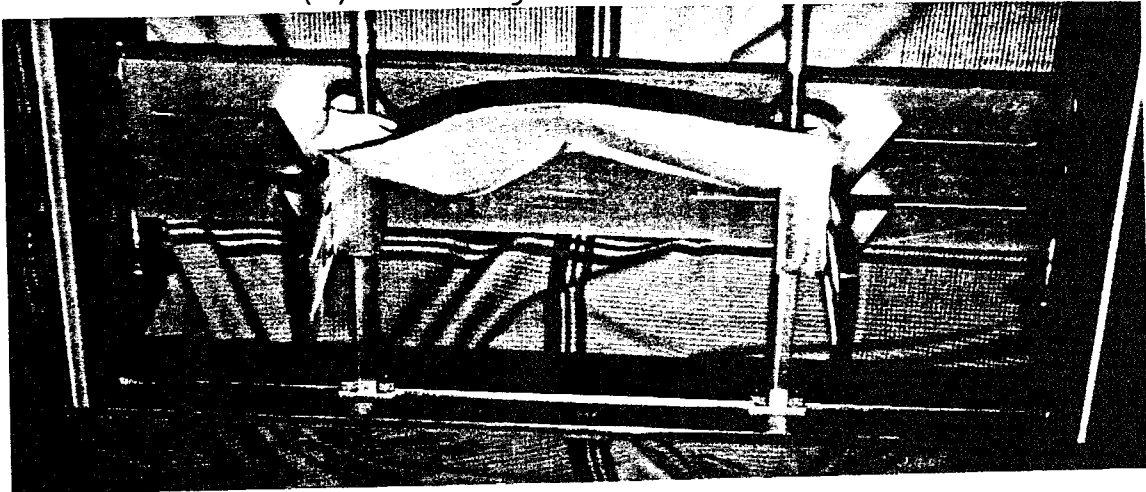

(c): Achieving Good Quality Collar Points

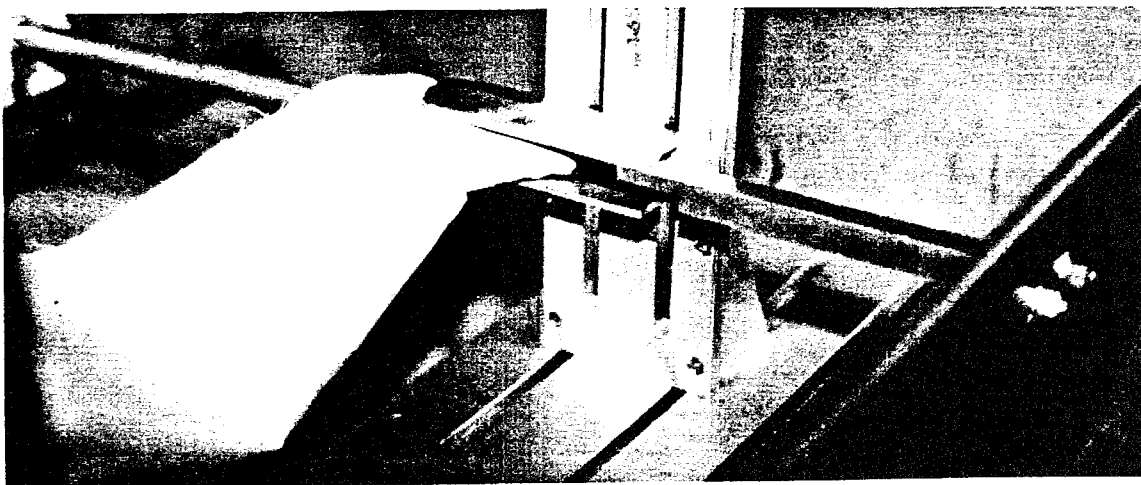

Figure 2.16: Tube Turner

turners. In this design, it was possible to apply force on the collar points after the turning process and the quality of the collar points was satisfactory. Figures 2.17 illustrates the sequence of the bench turner experiment.

Final Design Selection

The two bench machines tested showed that with each of the proposed ideas collar turning is possible, but the pivot turner has two advantages. First, locating of the collar point can be done automatically because the pivot turner concept is based on two clippers that rotate in opposite directions. Second, the quality of the collar point is improved since the C-shape brackets rotate in opposite directions and the two turners apply positive force on the collar points after they are turned.

The decision was made to design the proof-of-concept automated machine with the capability of adapting to turn different sizes of collars. The machine was to be loaded and unloaded using an ADEPT robot operated from a supervisory personal computer controller.

(a): Locating the Collar Points

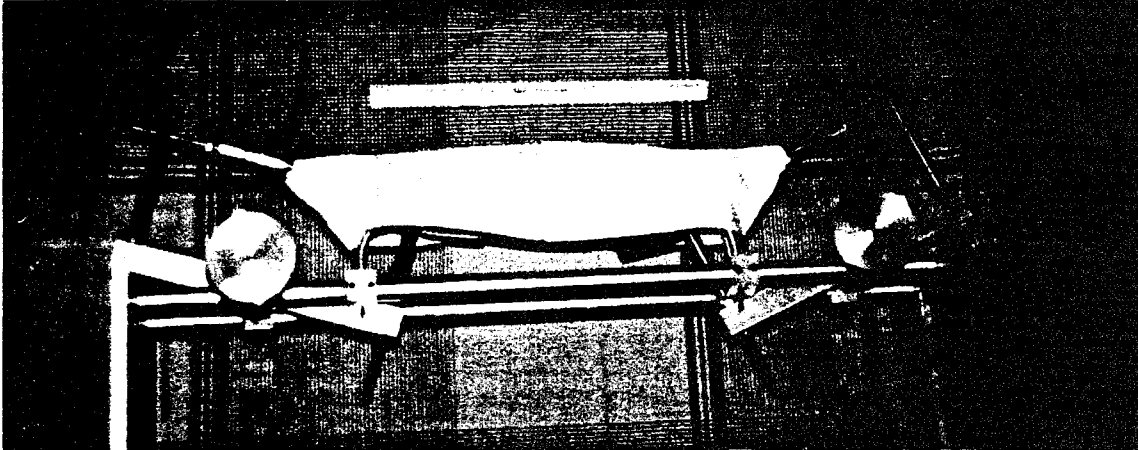

(b): Swivling the C-Shaped Brackets

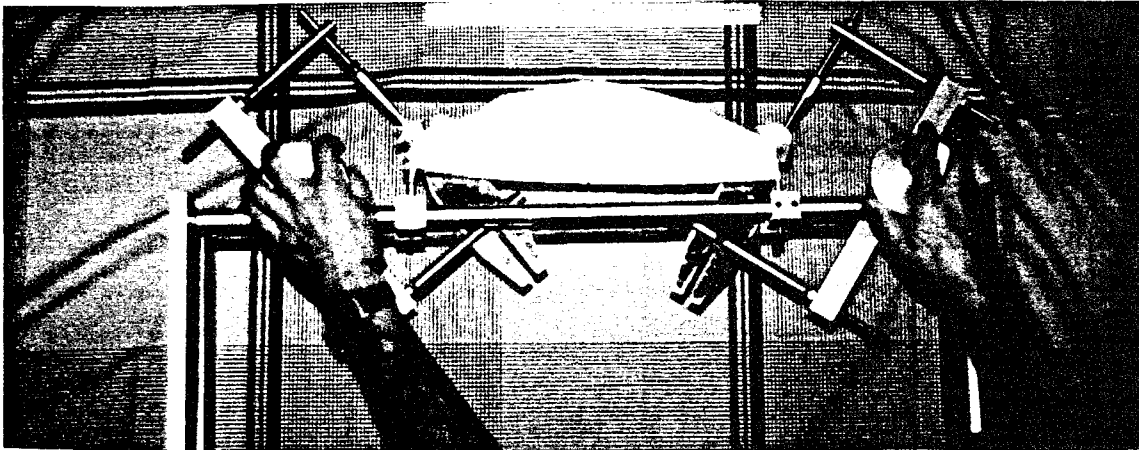

(c): Achieving Good Quality Collar Points

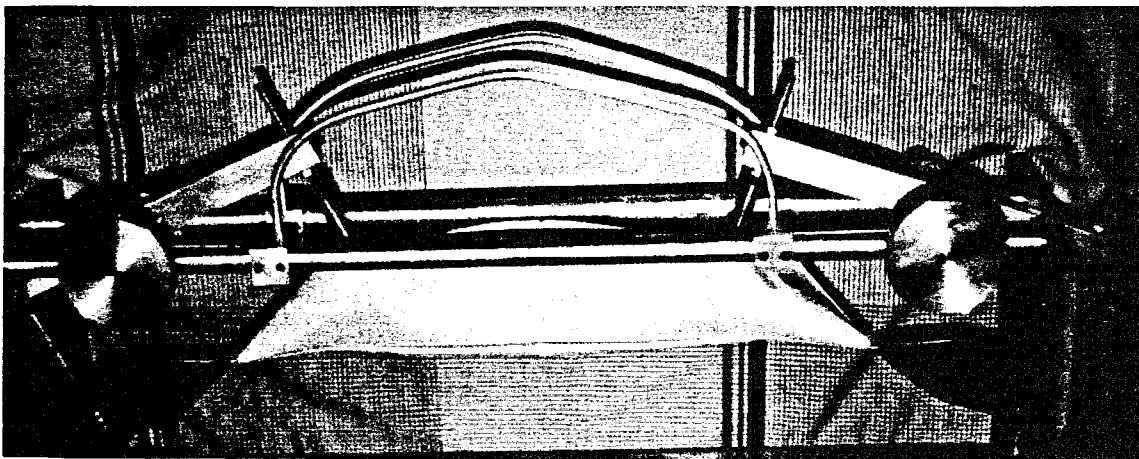

Figure 2.17: Pivot Turner

CHAPTER III

PIVOT TURNER DESIGN

Design Specifications

Turning Process

The study of the bench machine, described in chapter II, showed that in the initial sequence the two clipper tips need to locate the collar points, and during turning they are required to hold the collar points. This implies that the C-shaped brackets must be opened to receive the collar and closed to hold the collar points. Figure 3.1 (a) shows the clipper and turner pair in the open position. Figures 3.1 (b) through (d) show the sequence of loading the collar and holding the collar points. Figure 3.2 illustrates the three-step turning process for inverting the collar.

Drive Unit

Drive unit design specifications include swiveling the two shafts in opposite directions. One motor should be used to provide for synchronous motion of the clipper-turner pairs and minimize machine costs.

The motor torque required for collar turning was investigated by measuring the force involved in turning a collar workpiece with the bench machine. A linear spring-scale was connected to the C-shaped bracket as shown in Figure 3.3. Next the collar was turned by rotating the C-shaped bracket by pulling the spring-scale. The spring-

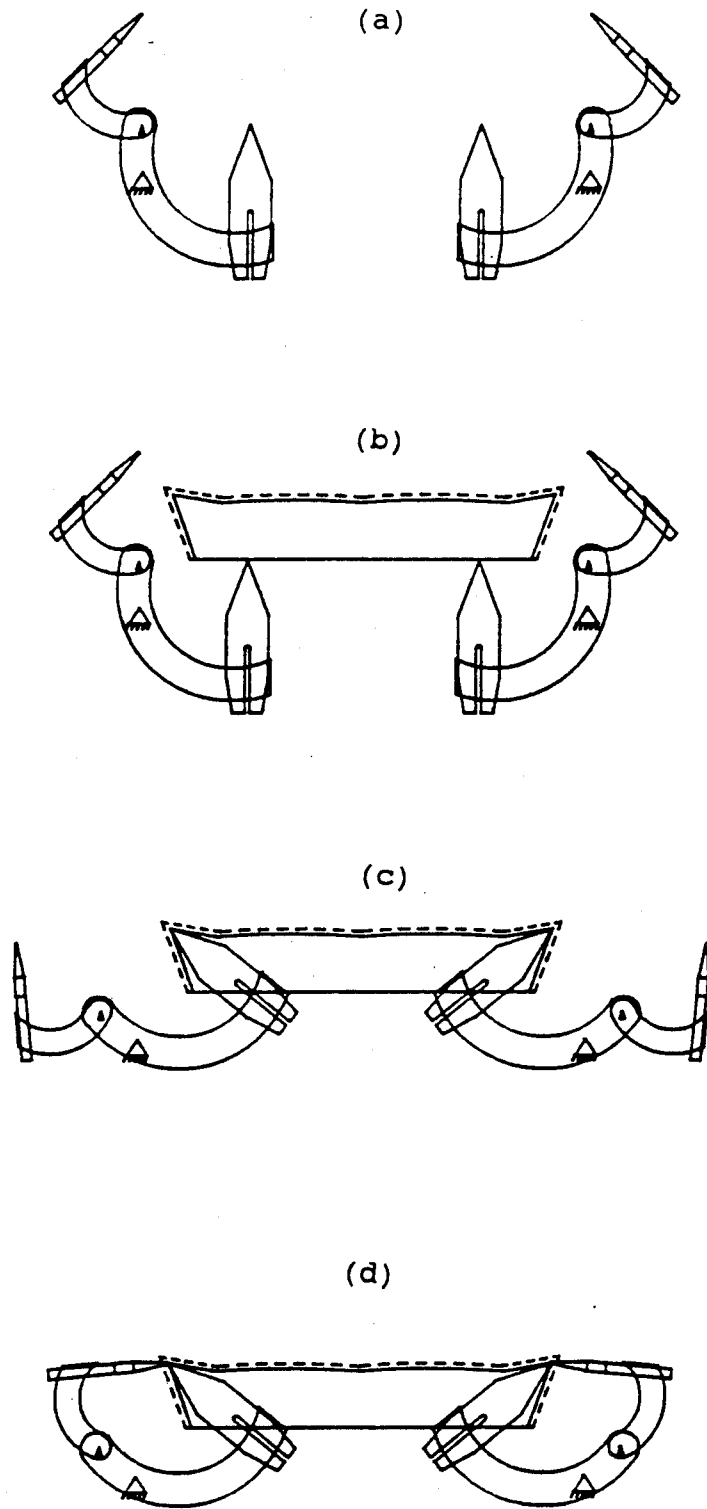
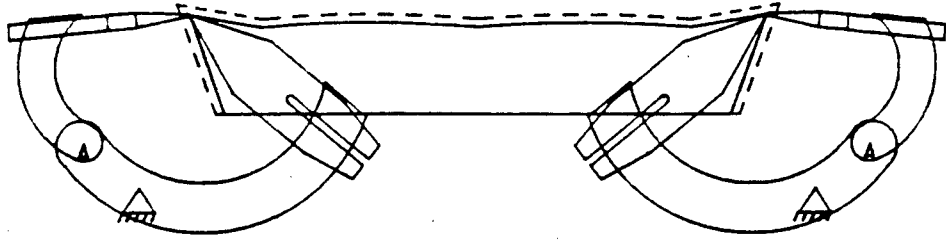
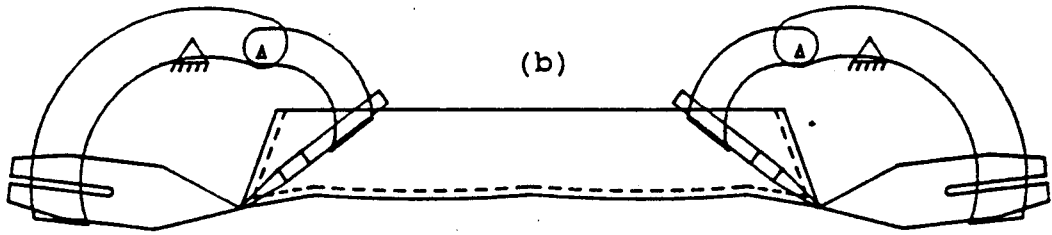

Figure 3.1: Turning Sequence

(a)



(b)



(c)

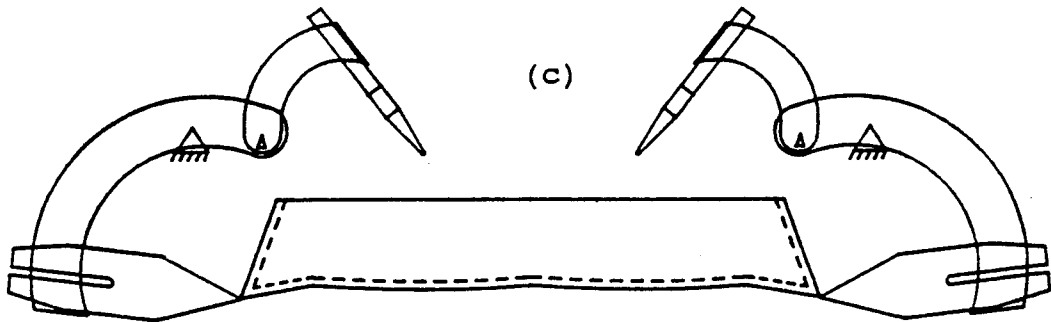

Figure 3.2: Turning Sequence (continued)

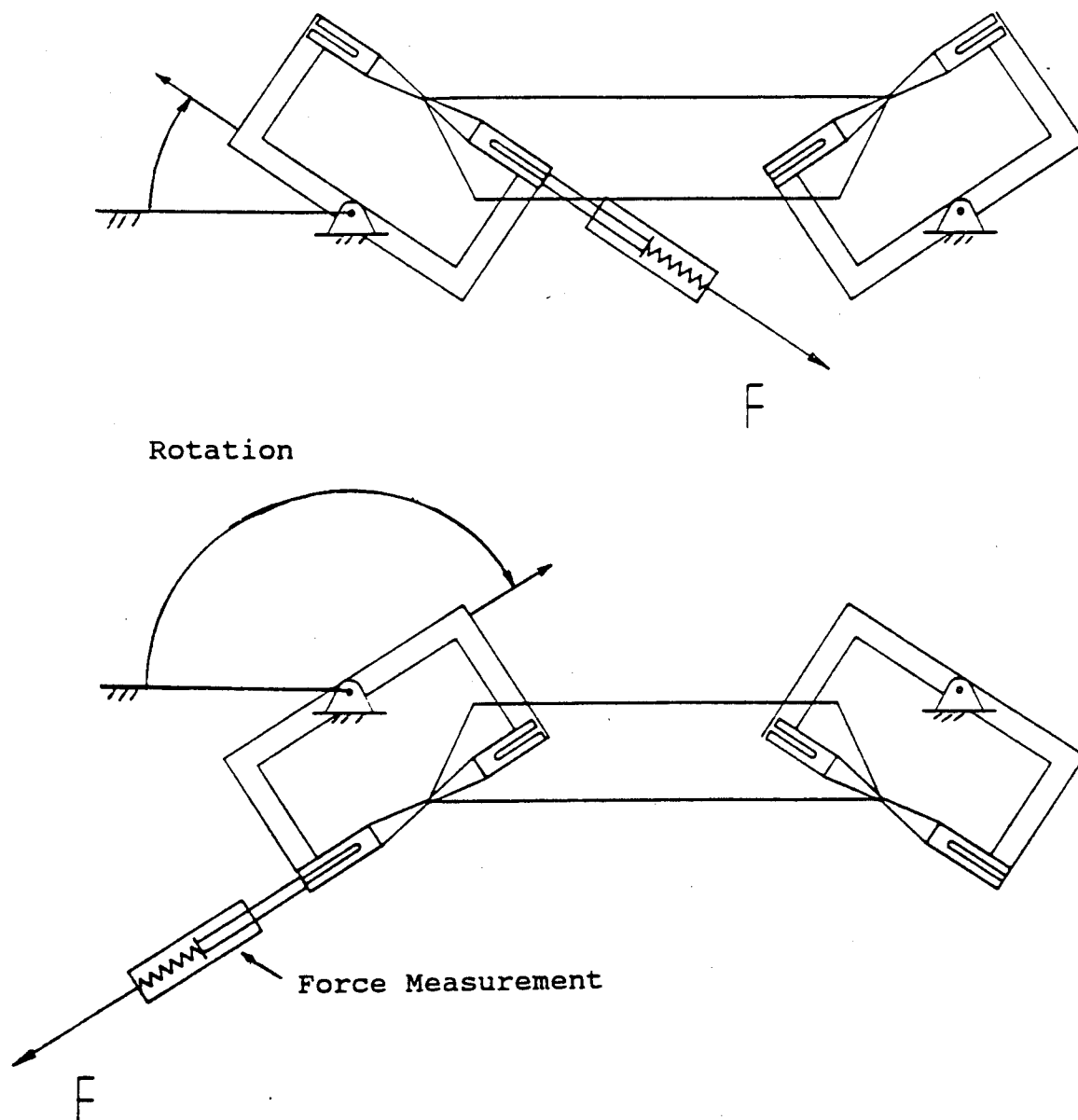

Figure 3.3: Force Measurement on the Bench Machine

scale readings were analyzed to yield the following:

$F=5 \text{ lb}_f$. -Maximum force required to turn the collar.

$R=5 \text{ in.}$ -Radius from pivot to spring-scale
connection.

$M=25 \text{ in-lb}_f$ -Maximum torque required to turn the collar.

Torque Required for Achieving Good Quality Collar Points

The maximum force needed to make a good quality of collar point was determined by experimental measurement.

The testing was done on a Lunapress machine located at Clemson Apparel Research in Pendleton. The experimental test configuration is shown in Figure 3.4.

First, the collar point was trapped between the clipper and turner. The operator then turned the collar. By repeatedly decreasing the turner air cylinder pressure, the correct pressure was found where the forces applied on the collar point by the operator were equal to the forces in which the turner was held by the air pressure. The results of this evaluation showed that for the given air cylinder diameter of $D=.9055 \text{ inch}$ and minimum pressure of 30 psi a force of 10.5 lb_f was required to make a good quality collar point.

Since the source air pressure in the industry is usually 70 psi , trapping the collar point against the clipper is done by a 24 lb_f force.

As a result the torque required for making a good quality point was determined to be done with a force of 20 lb_f at a radius of 5 inch , giving a moment of

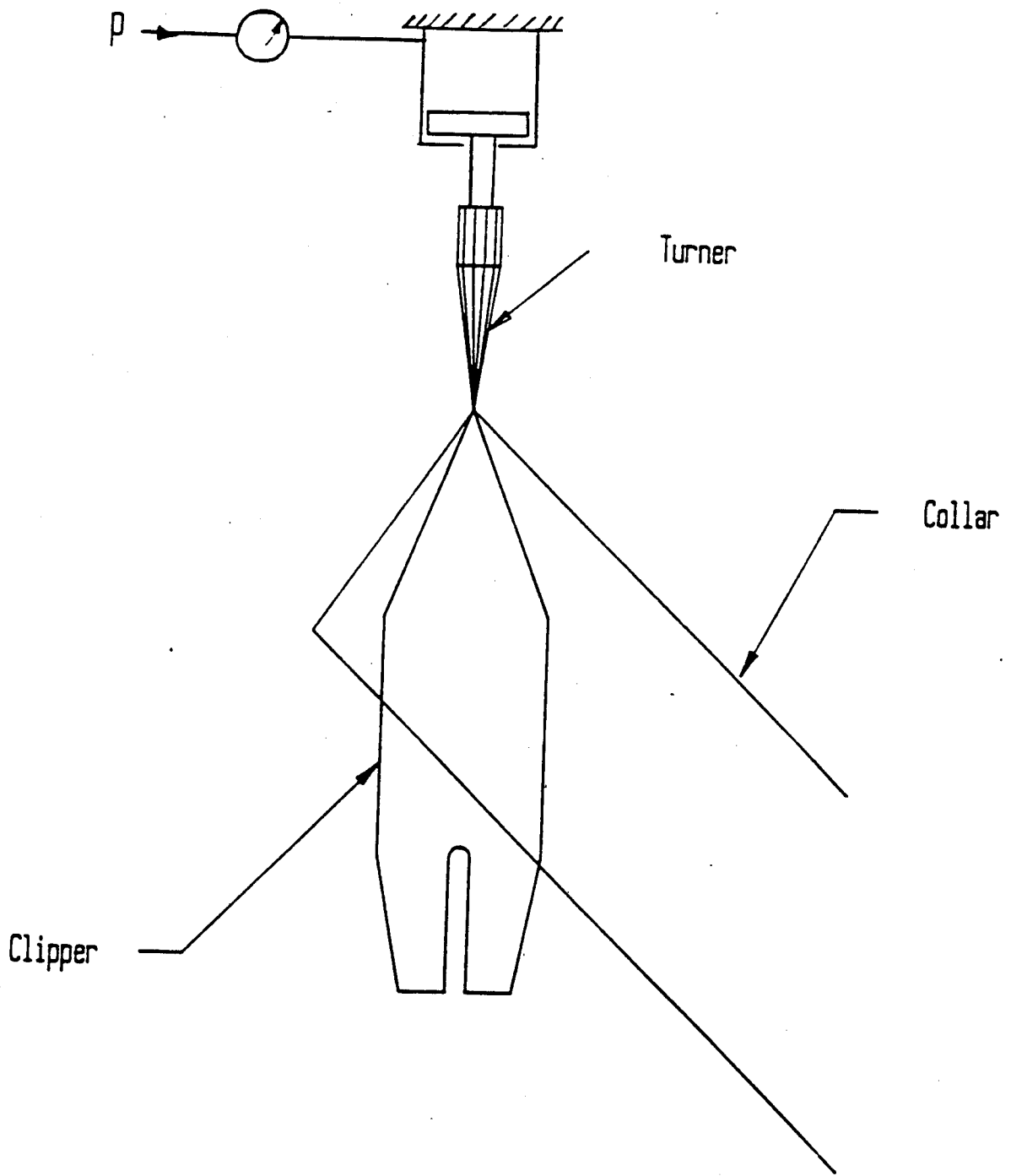

Figure 3.4: Experimental Testing of the Lunapress

100 in-lb_f of torque to make a good quality collar point.

These results show that a maximum torque of 100 in-lb_f is required for turning and ensuring the quality of a single collar point.

Holding The Rigid Ply

The turner machine applies forces on the collar during the turning process. The collar point is trapped between the turner and clipper tips during turning, then all the forces pass through the collar points. The collar is made of two plies in which one is weaker than the other. The turner machine should be designed in such a way that the turner-clipper support the weaker ply of the collar, permitting the rigid ply of the collar to drape during the turning process.

Turning Different Collar Sizes

The operation of turning different sizes and styles of collar is essential for the shirt design. The machine must have the ability to modify the distance between the two rotational shafts to turn different sizes of collars. The distance between the two collar points varies with collar size from 14.5 to 17.5 inches. The machine should change the distance between the two C-shaped brackets to turn these size collars. This distance can also be adjusted manually.

Turning Time

It is technically feasible to design the machine with very high speed turning. The collar can slide between the

two bridge components and cannot be predicted exactly. This slipping of the collar on the bridge limits the turning rotational speed. The turning cycle can be reduced to approximately two minutes.

C-Shaped Brackets Design

Clipper and Turner Connection

The turner machine comprises two C-shaped brackets, each featuring a clipper and turner pair. The C-shaped brackets swivel in opposite directions about two pivot shafts. To secure the collar points between the clipper and the turner, the C-shaped brackets must open to accept the collar. Each of the turners swivel approximately 90 degrees to allow the loading and unloading of the collar on the bridge. Therefore two rotating actuators are needed. The actuators must be connected to the C-shaped brackets since the turner motions are relative to the C-shaped brackets.

C-Shaped Brackets

Two alternatives were considered for design of the C-shaped brackets' motion. First, the use of an air cylinder for linear motion was tested. Figures 3.5 (a) and (b) illustrate the use of an air cylinder along the turner axis and along the pivot axis respectively. The second method was to swivel the turner around a pivot as shown in Figure 3.5 (c).

Discussion

The C-shaped brackets were required to open

approximately four inches to allow a collar to fit between the clipper and turner. The design of air cylinder along the turner axis for linear motion results in misalignment since the clipper and turner are expected to meet when the air cylinder is extended, as shown in Figure 3.5 (a). The air cylinder must move between the bridge rails during the turning process. This movement causes a difficulty since minimum distance between the bridge rails is desired. Also, interference between the end-effector and air cylinder housings could present a problem.

An air cylinder along the pivot axis solves the misalignment problem since the air cylinder is in a closed position, as shown in Figure 3.5 (b). Interference between the end-effector and C-shaped brackets may present a problem in this case. Swiveling the turner in rotational motion opens the turner and eliminates interference with the end-effector.

Misalignment

The tip of the turner must be aligned properly with the tip of the clipper since the collar points are trapped between them. To ensure that the alignment between the clipper and the turner is correct, the design uses load bearings. Those bearings protect the rotor actuator from the forces applied by the turner.

Discussion and Design

The design of the C-shaped brackets is shown in Figure

(a): Linear Motion

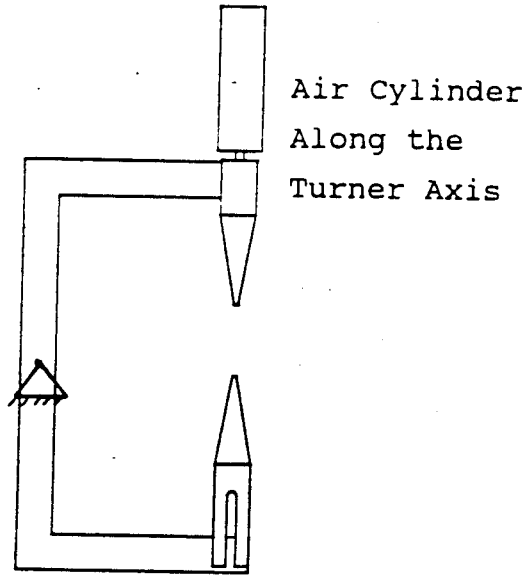

(c) Rotational Motion

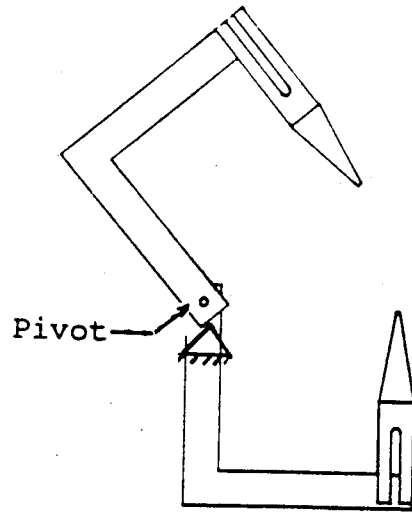

(b): Linear Motion

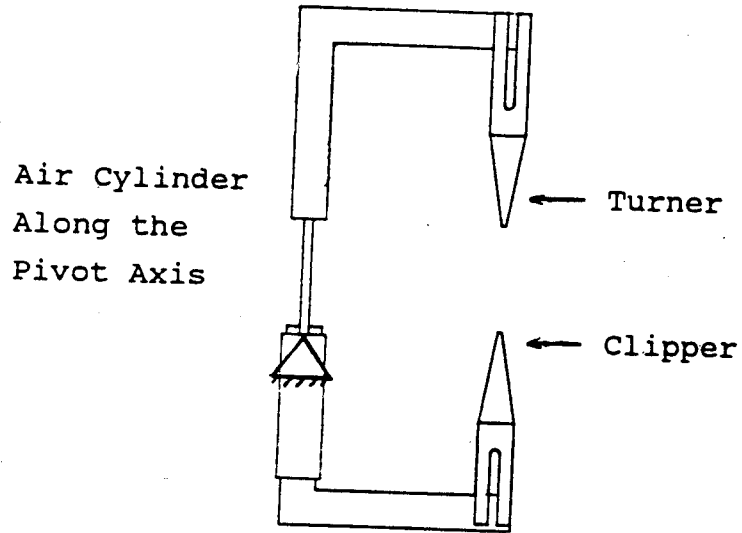

Figure 3.5: Design of Two C-shaped Brackets

3.6. Functionally, this design is similar to that of the Lunapress machine. The major difference is how the turner traps the collar point against the clipper.

Several advantages are gained from this type of bracket design. These advantages are (1) fewer components with increased reliability; (2) the collar point is more easily located along the bisector of the angle formed at the collar point; and (3) the bracket occupies less space during, allowing the end-effector more clearance to work.

Drive Unit Design

Method Selected

Several alternative methods for the design of the drive unit have been investigated. With this method it is possible to make use of one stepper motor to swivel the two C-Shaped Brackets in opposite directions. This approach also has the capability to change the distance between the two C-shaped brackets for the purpose of turning the different sizes of collar.

There are five different alternatives that were considered for swiveling the C-shaped brackets in opposite directions.

1. Using two servo motors as illustrated in Figure 3.7 (a) shows the capability to turn different sizes of collars.
2. One servo motor with a gear transmission as illustrated in Figure 3.7 (b) shows that this idea does not have

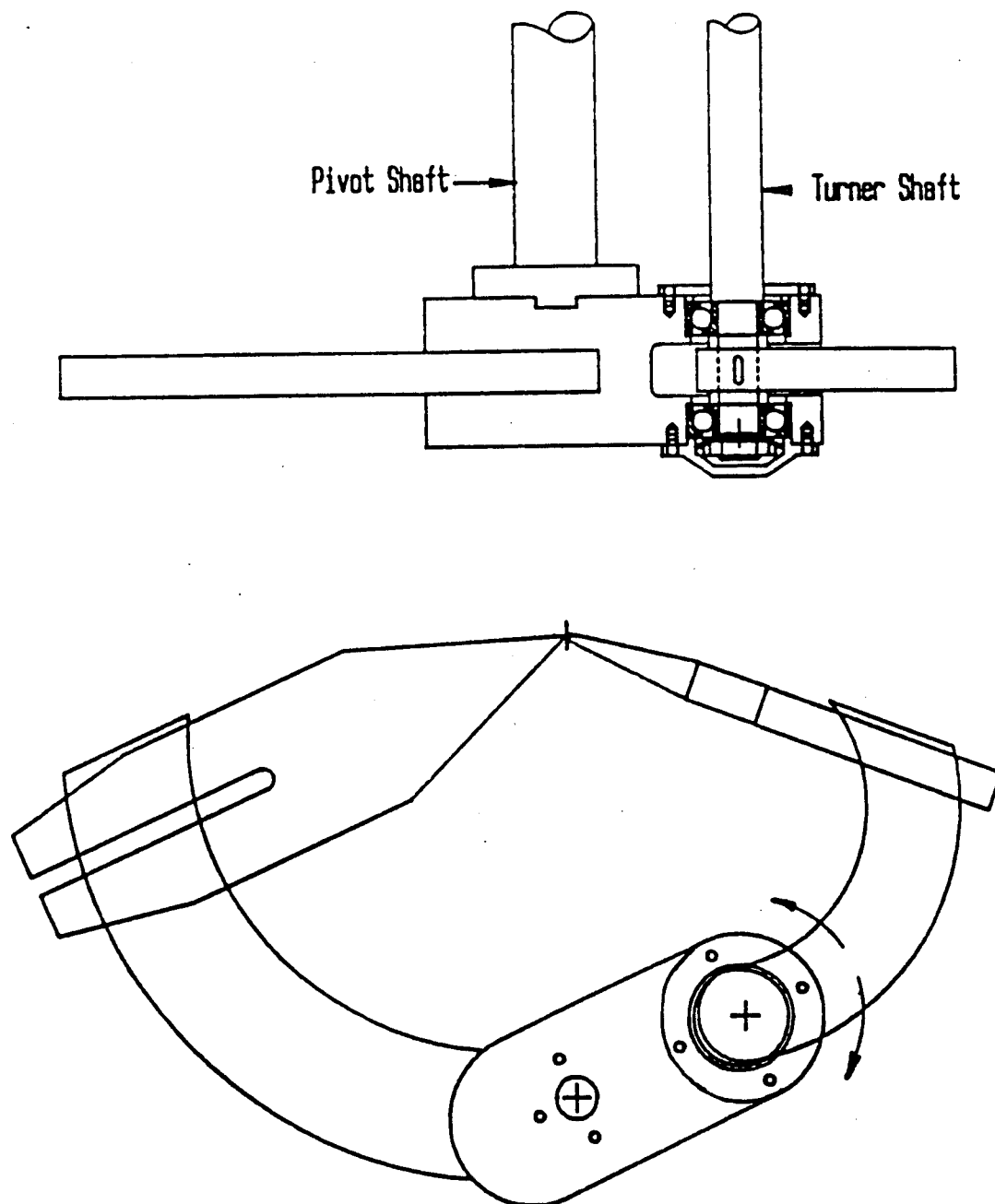

Figure 3.6: Configuration of the C-Shaped Brackets

the capability to turn different sizes of collars.

3. air cylinder and two slide rods as illustrated in Figure 3.8 (a), shows that this idea has the capability to turn different sizes of collars.
4. One step motor and two slide rods are used as shown in Figure 3.8 (b), the mechanism has the capability to turn different sizes of collars.
5. One stepper motor and a timing belt are used as illustrated in Figure 3.9, the method has the capability to turn different sizes of collars.

Discussion

The C-shaped brackets swivel in opposite directions in all the above designs. This decision was made based on the idea of using one stepper motor and a timing belt turning between four sprockets. Two sprockets are connected to two main shafts, one sprocket for each shaft. The third sprocket is connected to the machine structure; and used to reverse the direction of the belt. A fourth sprocket is connected to the stepper motor which turns the belt. Figure 3.9 shows the process of changing the distance between the two shafts to support turning of a different collar size.

Stepper Motor and Harmonic Drive Selected

The maximum moment that is required for double point collar turning is 200 in-lb, because there are two collar points. It is possible to select a small stepper motor with a big gear reduction since the turning sequence is

(a): Using Two Servo Motors

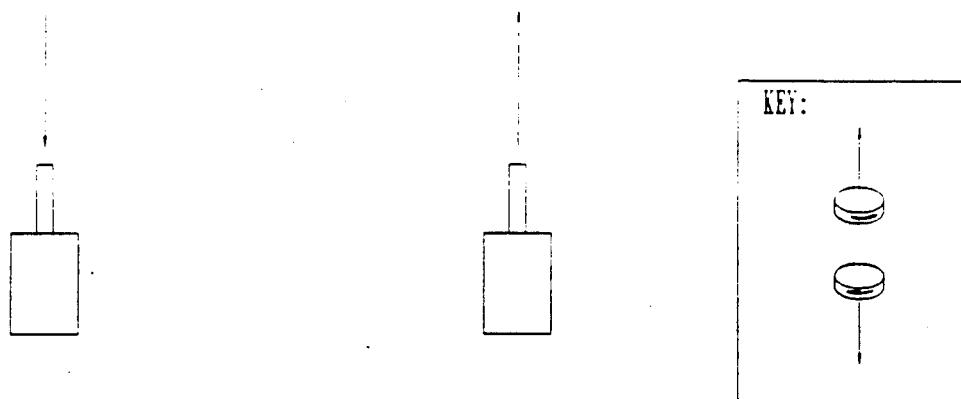

(b): Using One Servo Motor and Gear Transmission

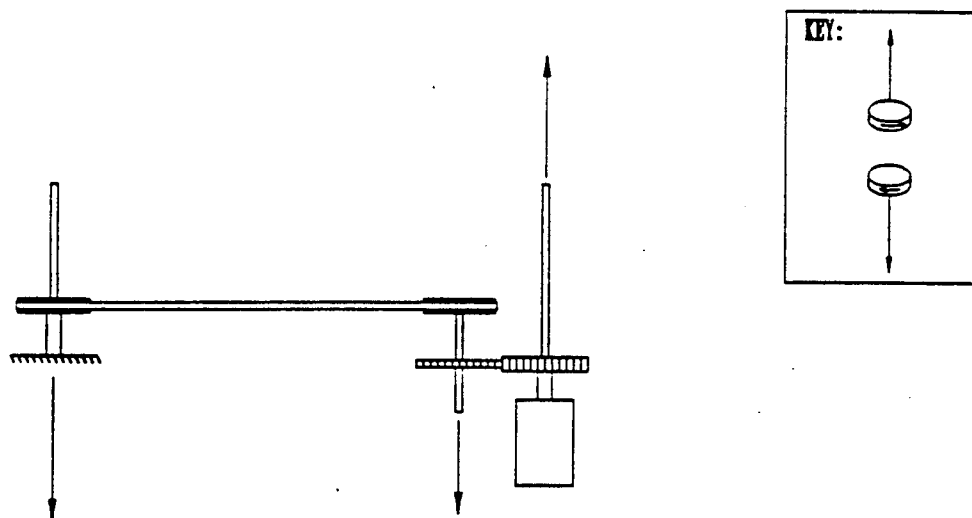

Figure 3.7: Drive Unit Design

(a): Using Air Cylinder

(b): Using Servo Motor

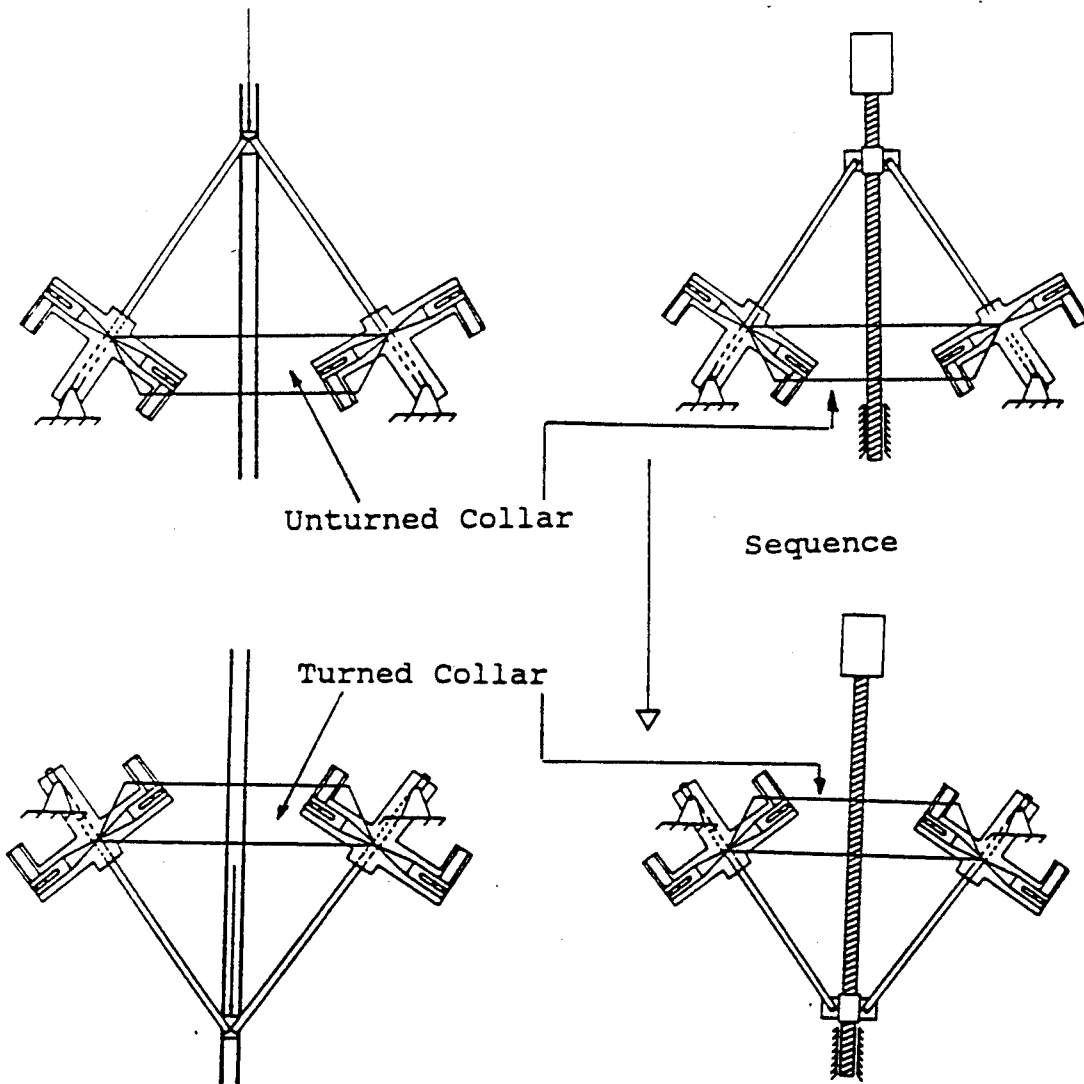

Figure 3.8: Drive Unit Design

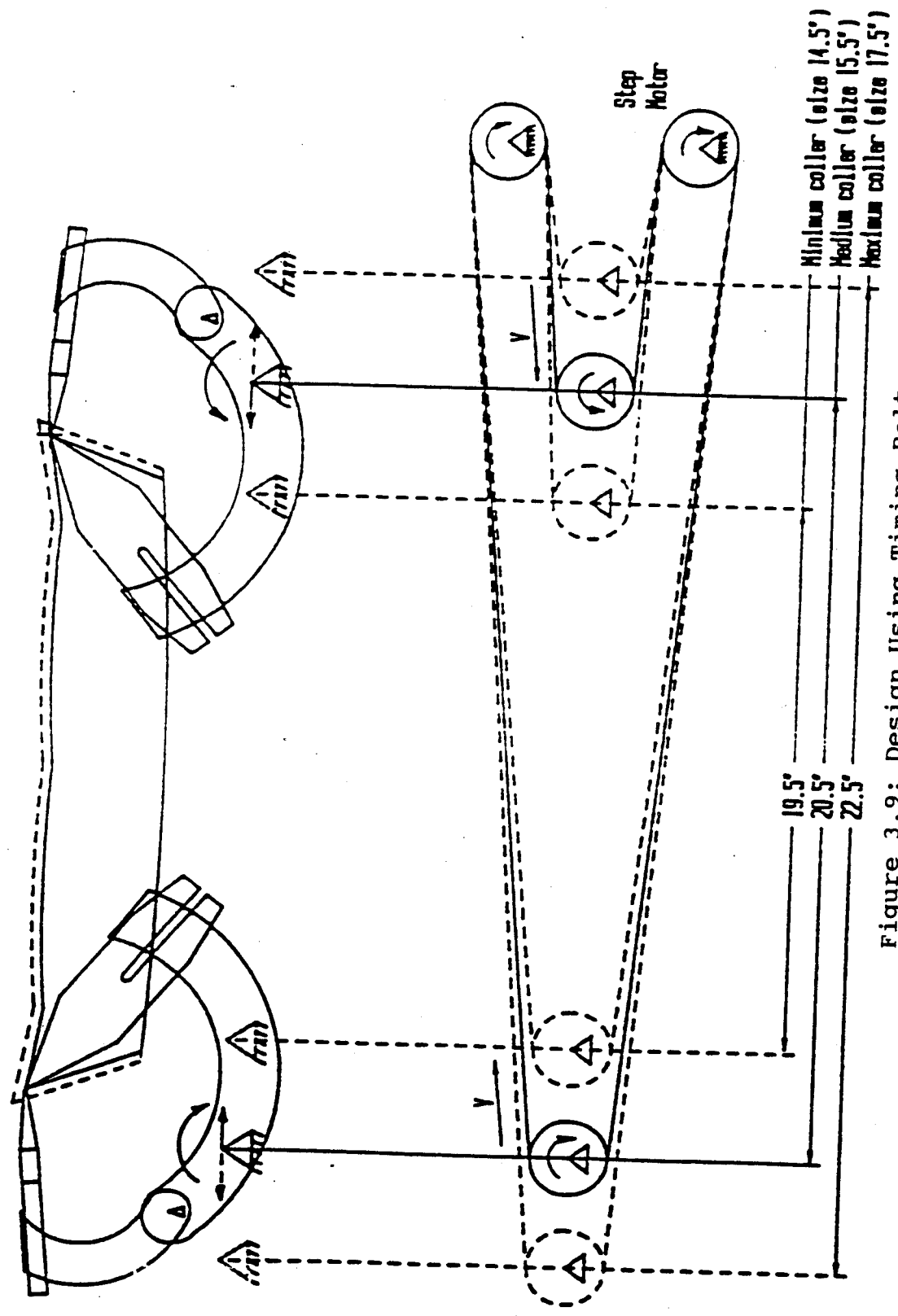

Figure 3.9: Design Using Timing Belt

considered slow compared to a standard stepper motor speed. The gear reduction increases the torque but decreases the angular speed. The proper gear reduction must account for the timing sequence and the drive torque required discussed in the next chapter.

Turning Sequence

The C-shaped brackets swivel at 145 degrees to turn the collar. The speed of the motor varies from 10^3 to 10^4 steps per second as shown in Figure 3.10. A motor speed of 1000 steps per second was selected for design purposes with an option to increase the speed by a factor of 10.

Two hundred steps per revolution of the motor shaft gives a motor speed of 300 rpm. Using a gear reduction of 60:1, the output shaft speed will be 5 rpm. With the maximum speed chosen the system speed can be increased by a factor of 10 and the timing sequence reduced to 0.48 seconds. The stepper motor speed is determined by the signal sent from the DCX controller board supported by a microcomputer.

Drive Turner Design

A good quality collar point requires 20 lbs of force to be applied along the turner axis and through the point. The torque required for per collar point is 100 in-lb, because the rotational radius is 5 in. Appendix E illustrates a rotary actuator connected to the main shaft. The speed of rotation may be controlled through the use of

Model Number: UMD 268-21 Motor/Driver
 Oriental Motor U.S.A., Corp.

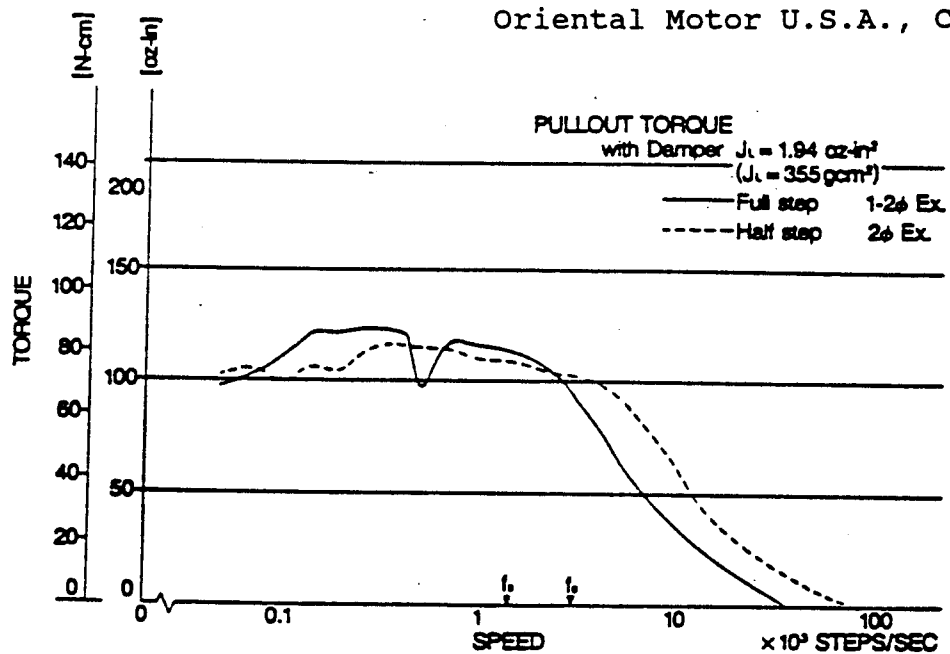

Figure 3.10: Speed of the Stepper Motor [7]

the computer controls, and the rotational motion stopped by using mechanically adjustable cushions.

Bridge Design

Bridge Shape

The correct geometric shape of the bridge is essential for turning the collar. The shape of the bridge was determined after testing bench geometric configurations. The bridge test selected is shown in Appendix E-Figure E.5.

Bridge Connection to the Stationary Points

The design presented in Figure 3.11 shows the bridge connected to the main shaft. The connection must be made with a bearing support since the main shaft must be permitted to rotate. A space is required between the two bridges to ensure that the C-shaped brackets pass through and do not touch the bridge when they swivel.

Holding the Rigid Ply

The rigid ply must be trapped between the turner and clipper tips during the turning process. This operation of trapping the rigid ply is significant since the weaker ply does not have the ability to keep the clipper-turner force from tearing the material during the turning process. Three different approaches are discussed to address this issue.

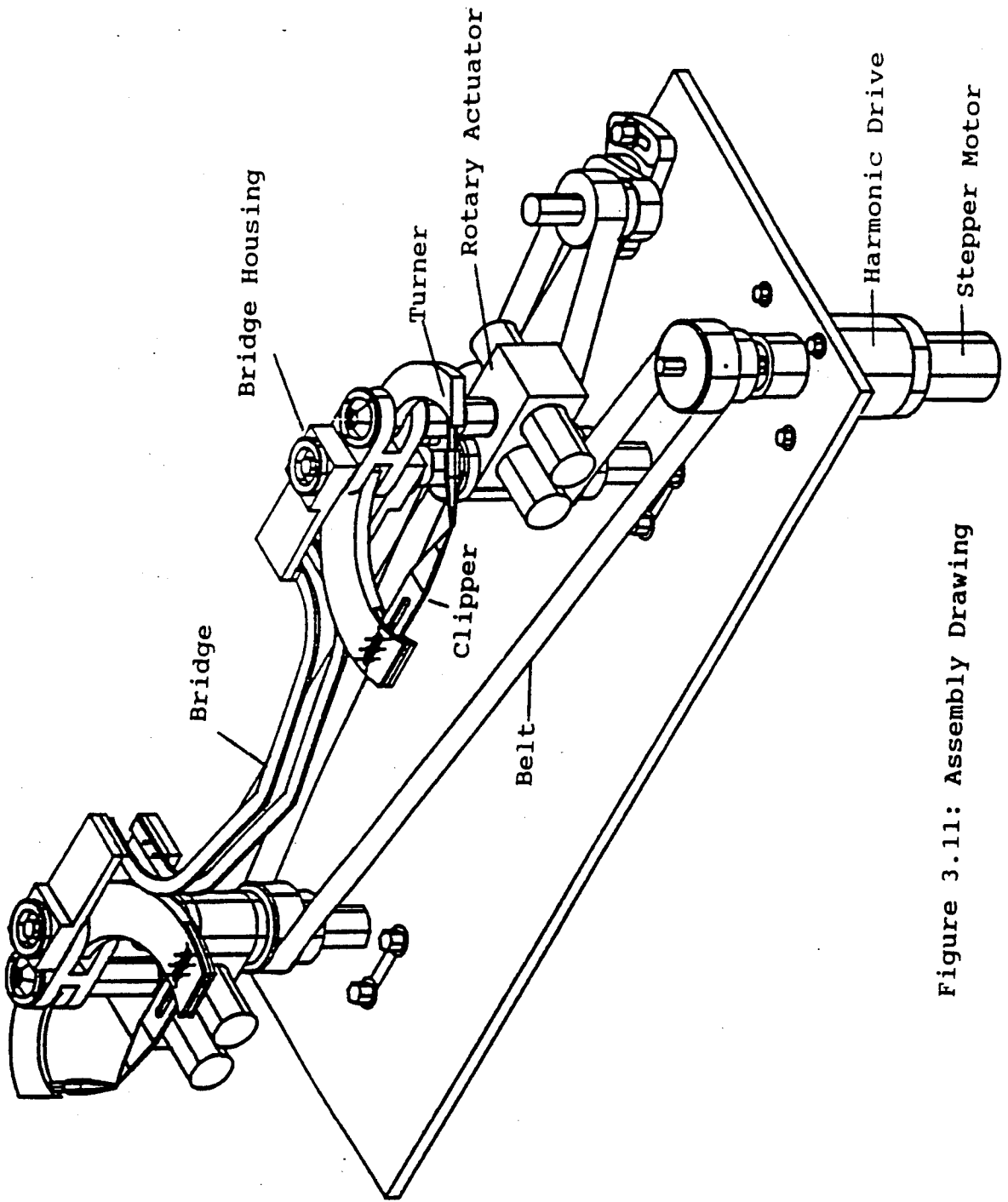

Figure 3.11: Assembly Drawing

1. Air Jet

The method presented in Figure 3.12 (a) uses a jet of air to fold the corner ply. After actuating the air jet and turning the corner ply, the collar point is ready for actuating the turner against the clipper and trapping the rigid ply.

2. Angle Between the Turner and Clipper Axis

The position of the clipper is at a 10 degree angle, relative to the turner, as shown in Figure 3.12 (b). This clipper-turner orientation can hold the rigid ply. This idea was previously evaluated in the Lunapress machine. The angle between the turner and the clipper is 10 degrees as measured on the Lunapress. Use of this method in the turner machine produces two problems. First, there is not enough space between the two pieces of the bridge to allow movement of the turners since the angle of the turner axis is in a vertical position in relation to the bridge surface. Second, after the turning process is completed, the two turners are not in the same surface since each turner is placed in an angle of 10 degrees on a different surface.

3. Angle on the Tip of the Clippers

The idea based on small angles on the tip of the clippers is presented in Figure 3.12 (c). The mechanism is similar to the second idea, except in this case the tip of the clippers, not the turners, have the angle.

(a): Air Jet

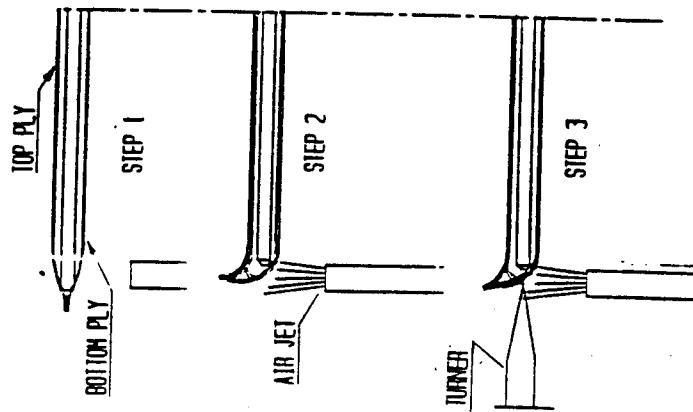

(b): Angle Between the Turner and Clipper Axis

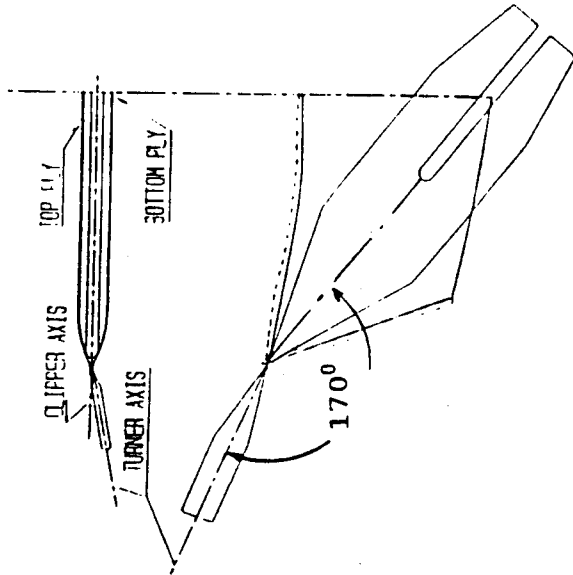

(c): Angle On the Tip of the Clippers

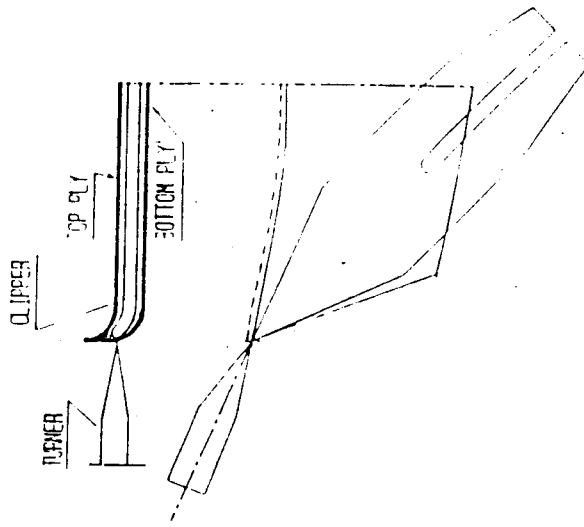

Figure 3.12: Holding the Rigid Ply

Decision

The three methods for pinning the collar tip between the collar and clipper were considered. The decision was made to use the air jet. Figure 3.13 shows how the air jet was applied in the turner machine. The air jet proved satisfactory after completing several experimental modifications and evaluations.

Turning Process

There are six steps involved in the turning process. These steps are turner opening, collar loading, collar points locating, collar points trapping, collar turning, and turner retraction. In the first step the turning device is at the beginning of a new cycle and is ready to accept a fresh collar. The turner has now swiveled in such a way that the end-effector can easily load the collar on the bridge of the turning device. The position is illustrated in Figure 3.14 (a). In the second step the collar is loaded on the clippers. It is significant that the two plies of the collar slip over the bridge. The position is illustrated in Figure 3.14 (b).

In the third step, the clippers swivel to locate the collar points. The position is illustrated in Figure 3.14 (c). The turners are actuated to trap the collar point against the clipper in the fourth step. This smooth movement of the turners actuates the air jet to trap the rigid ply. The position is illustrated in Figure 3.14 (e). In the fifth step the two C-shaped brackets are actuated to

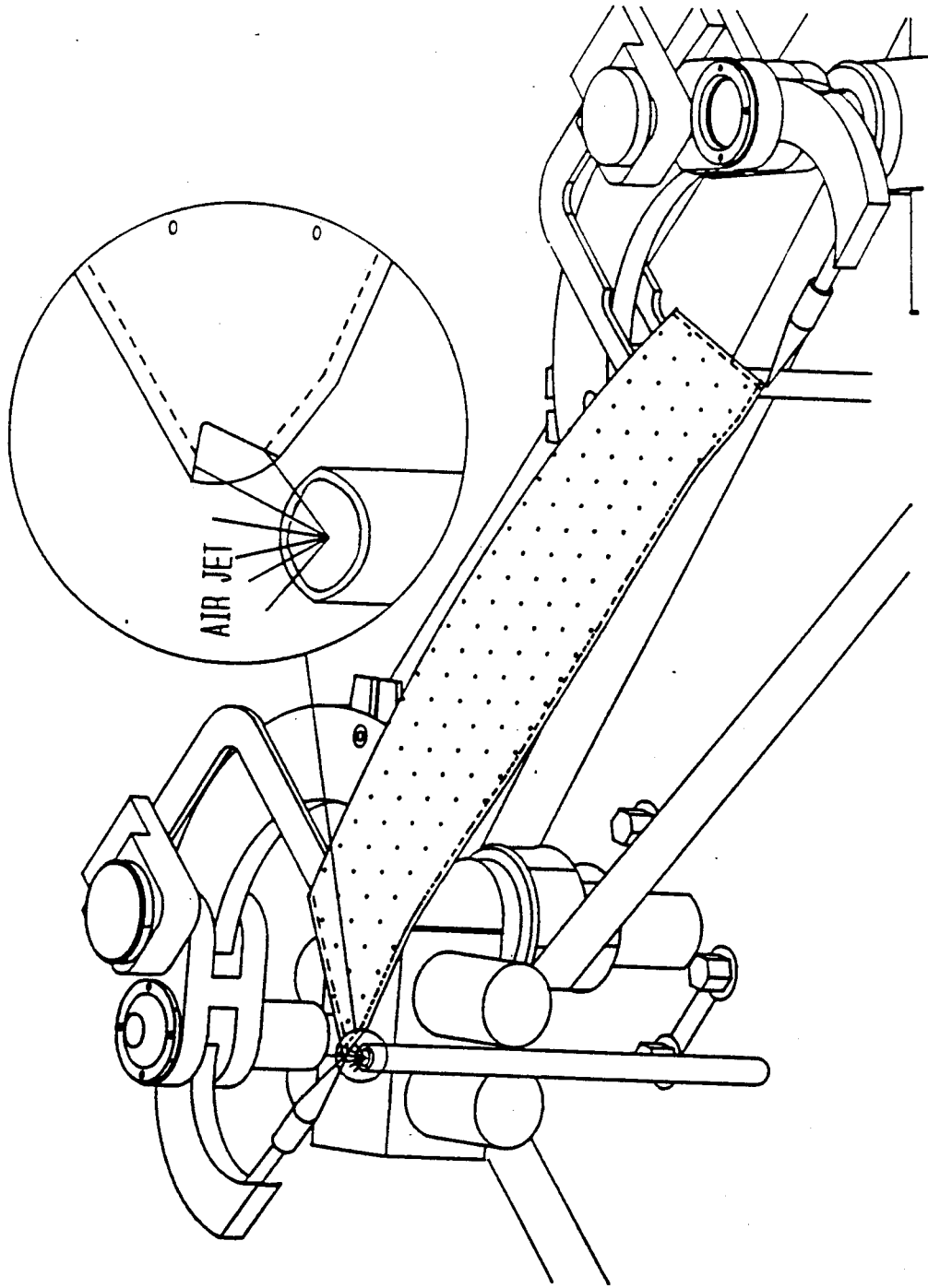
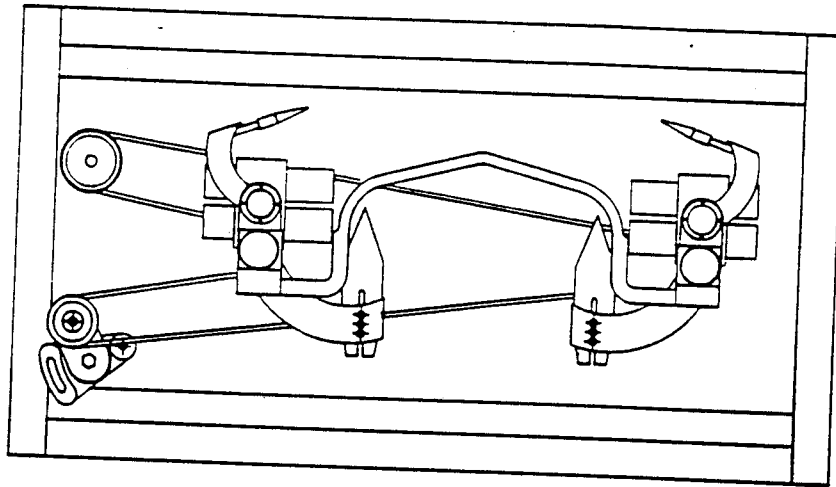
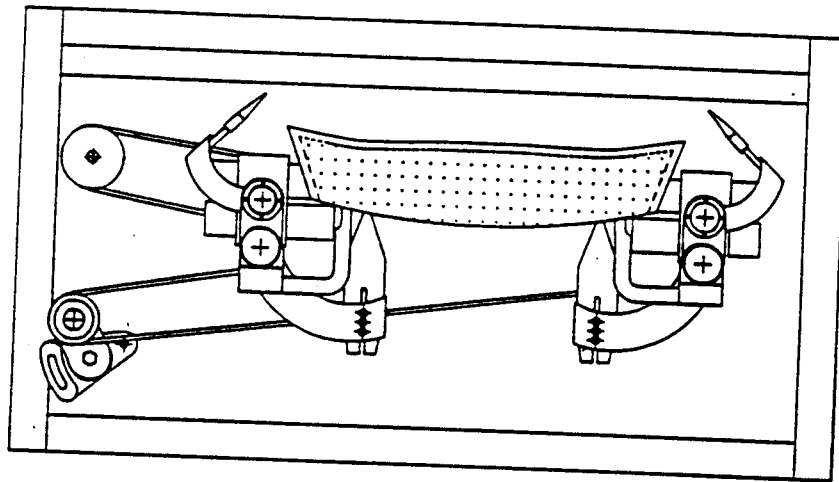

Figure 3.13: Holding the Rigid Ply

(a) : STEP 1



(b) : STEP 2



(c) : STEP 3

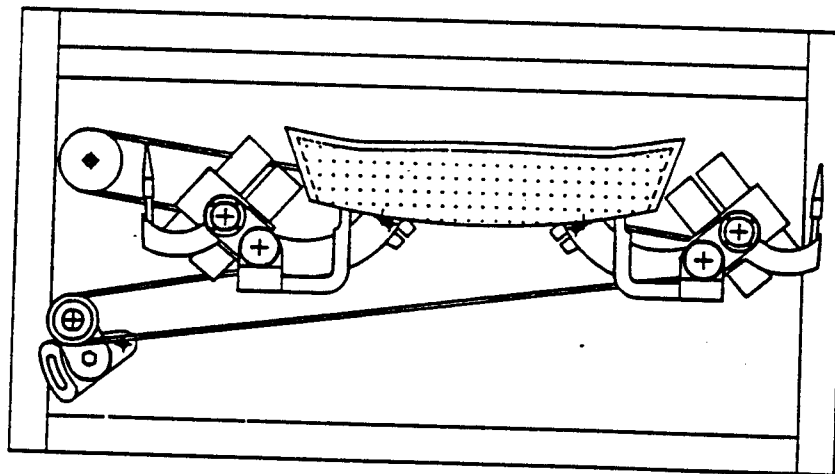
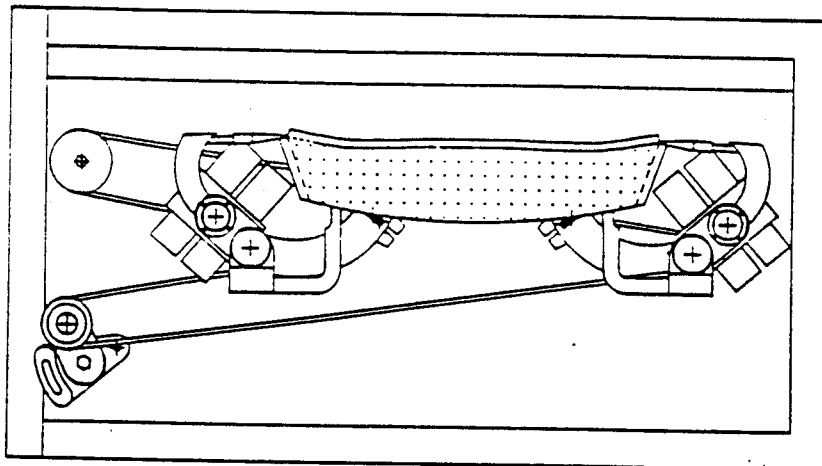
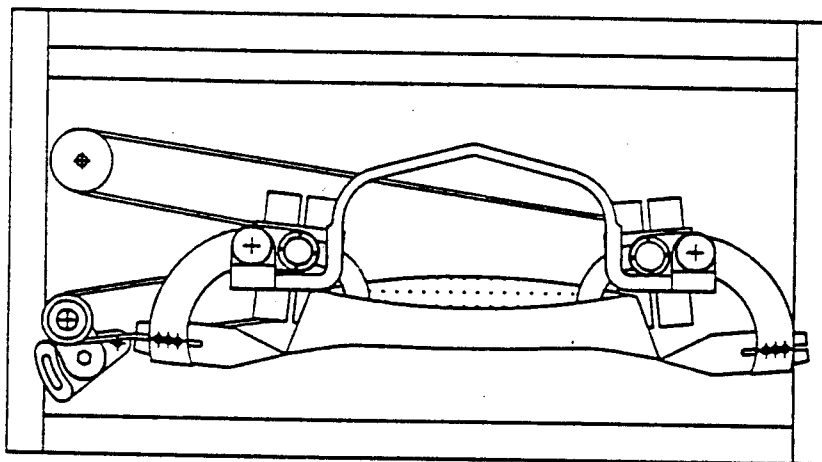

Figure 3.14: Turning Process

(d): STEP 4



(e): STEP 5



(f): STEP 6

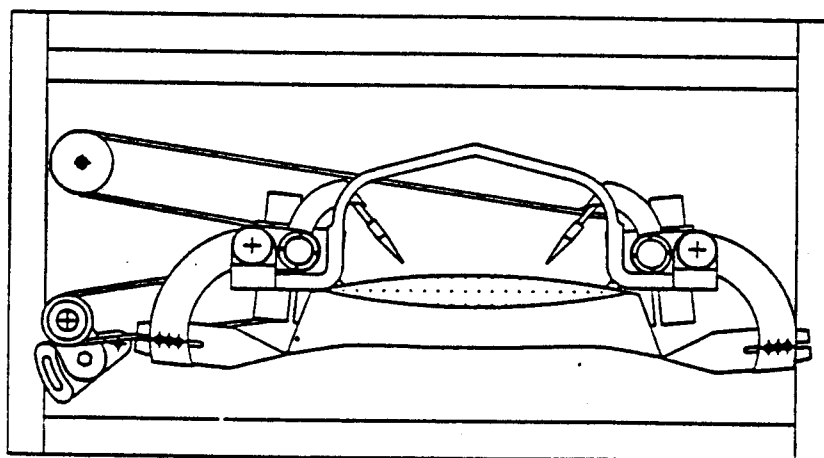

Figure 3.14: Turning Process (continued)

swivel in opposite directions so that the collar is turned. The position is illustrated in Figure 3.14 (f). In the final step the turners are again actuated so that they are away from the collar. This allows the unloading of the collar from the turning device. The position is illustrated in Figure 3.14 (g).

Modified Drive Unit Design

Introduction

The bench machine double point pivot turner has been experimentally tested and the concept has been verified to work satisfactorily. An improvement to the drive unit which rotates the C-shaped brackets in opposite directions would be to use a four bar mechanism to accomplish the rotational motion. This improvement permits future automated machine designs for collar turning, to turn different size and style of collar without mechanical adjustments.

Drive Unit Using a Four Bar Mechanism

A stepper motor has been used in the turner machine to rotate the two C-Shaped Brackets. If the stepper motor is replaced by a four bar mechanism, as shown in Figure 3.15. The C-shaped bracket is part of the four-bar mechanism, with the right drive link and the four-bar mechanism connected to the belt sprocket. There are two advantages to this modified design.

a). The main shaft that holds the C-Shaped Bracket can

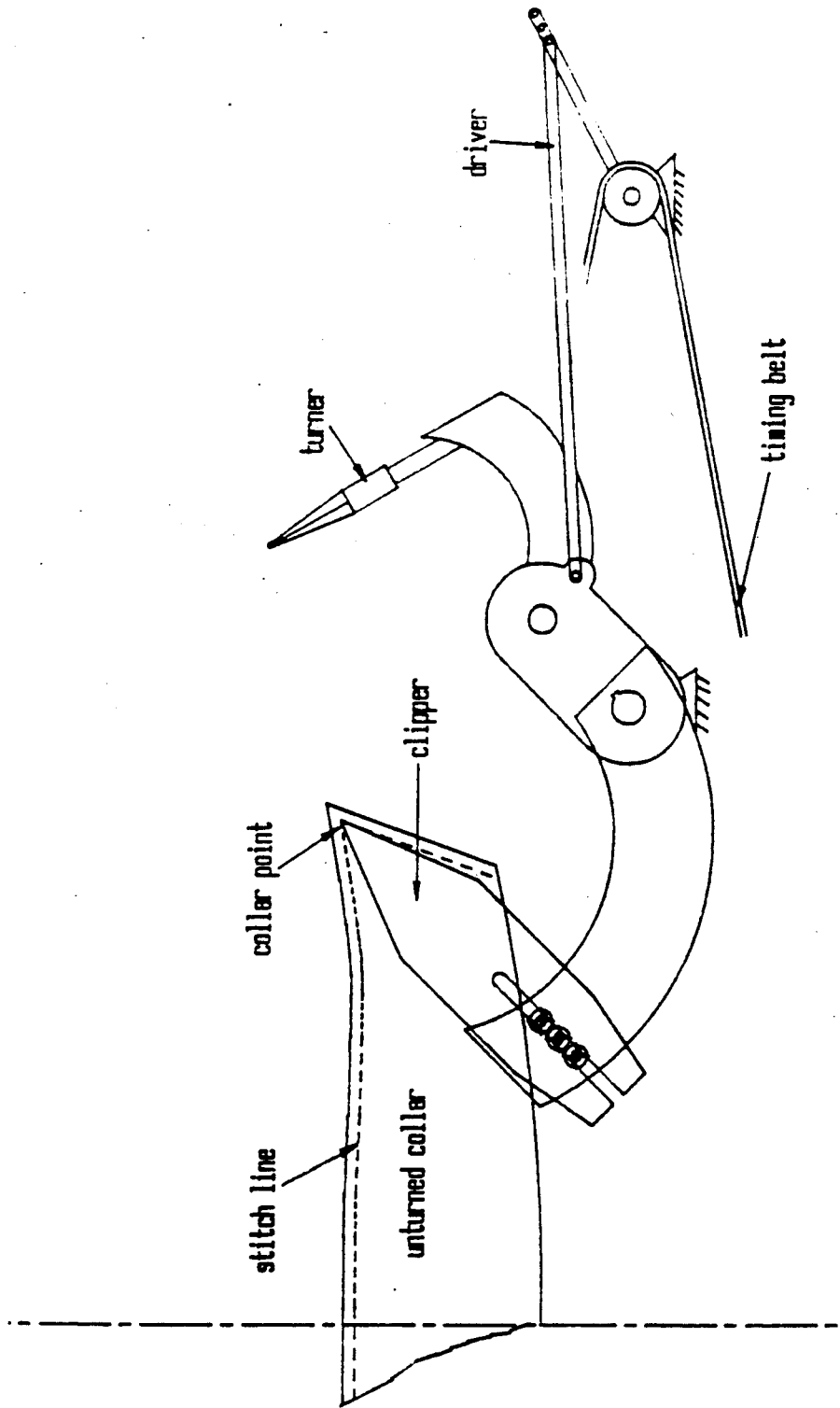

Figure 3.15: Modified Drive Unit Design

be adjusted for turning different size collar. This is simpler from the previous design since the timing belt is connected to the four bar mechanism.

- b). By selecting the correct length for the four bar mechanism, the desired velocity profile can be designed into the turning machine.

Conclusion and Decision

The modified design that was presented has the potential of being used in a commercial machines. Therefore, an analysis must be conducted to impose correct position, velocity, and acceleration during the turning process. Appendix A presents kinematic and dynamic models for this drive configuration for determination of the correct link sizes.

CHAPTER IV

EXPERIMENTAL EVALUATION

System Integration

Parts Fabricated

Appendix D describes the assembly drawings of the system. Most of the parts were fabricated from Aluminum 6061 selected for its high strength and weight ratio and low production cost since it is easily fabricated, except parts produced from AISI 4043. Most parts black were anodized to minimize stray reflections and image distortion.

Assembly

Machine assembly was done at the Engineering Services of Clemson University. At the time of the assembly misalignment and adjustments were corrected. The assembly of the stepper motor and harmonic drive reductions are described in Appendix F. The stepper motor wiring connects to the driver that can accept command from the DCX controller board on the system supervisor. The driver is directly plugged into a 110 volt supply. The wiring of the stepper motor is presented in Appendix E.

Proximity Sensors

The stepper motor operates on incremental commands and does not have an absolute position encoder. An Indicative Proximity Sensor (I.P.S.) was used to establish a home posi-

tion and initialize the machine. The I.P.S. is attached to the base of the machine to establish an initial position as a reference point for the rotation of the C-Shape Brackets.

Automated Loading-Turning-Unloading Experiment

Introduction

All experiments of loading, turning, and unloading of the collar from the bench machine were done manually. The experience gained from this experiment was used in the design process of the automated loading-turning-unloading process. The objective of developing a collar loading-turning-unloading demonstration was to evaluate the interaction between a robot end-effector and the turning machine.

This report concerns here only with the automated loading-turning-unloading process. The end-effector was designed by Ajay Gopalswamy [3] and the supervisory control programming developed by Eric Torgerson [4].

Work Area

The double point pivot turning device is situated in the work area on one side of the robot. Figure 4.1 gives the overall layout of the workspace including the robot end-effector, destacking device and turning machine.

Loading-Turning-Unloading Sequence

The sequence of loading, turning and unloading a shirt collar involves several tasks starting with the gripping of the unturned collar and ending with the turned collar. The process objective is to use the robot to assist in the work

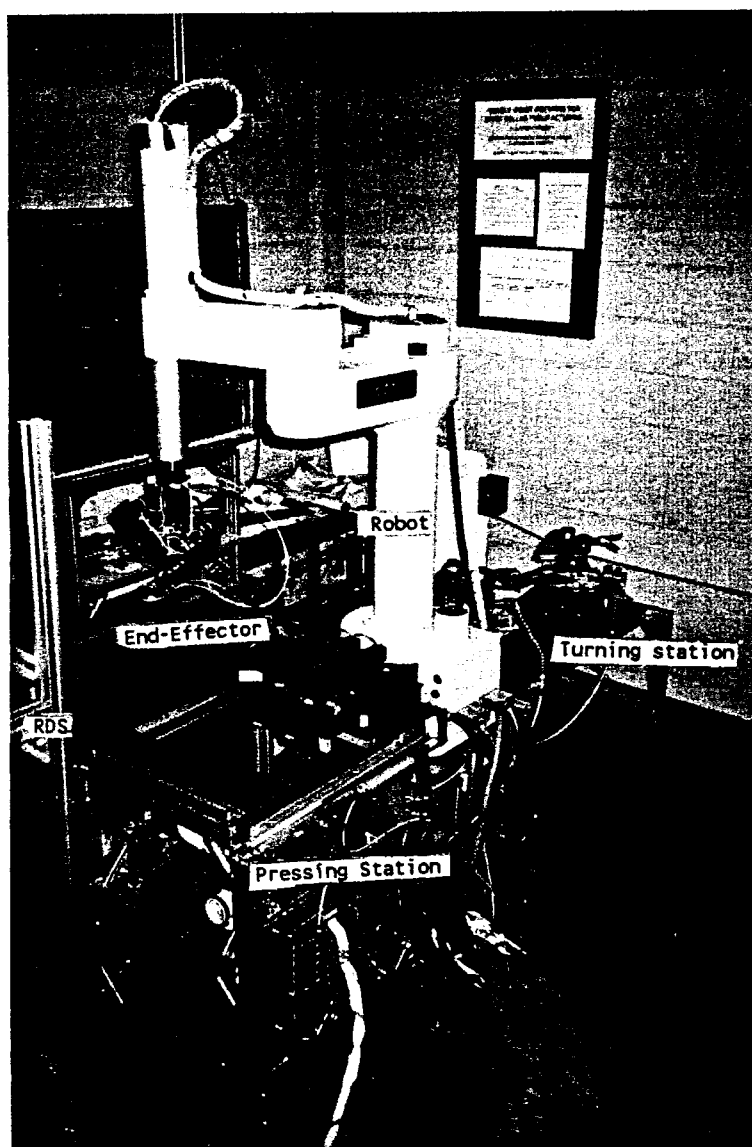

Figure 4.1: Overall Layout of the Workstation

area. In this sequence the end-effector picks the collar from the destacker device and loads it on the turning machine. After the turning machine has turned the collar the robot end-effector does the unloading of the collar from the turning machine. The sequence of operations is as follows

a). Gripping the workpiece by the robot end-effector-To be able to grip the workpiece by the end-effector, a destacking device was designed to hold the collar by three fingers so that the robot end-effector is capable of holding the collar by its two grippers. Figure 4.2 (a) shows an unturned collar which has been automatically loaded from the destacking device.

b). Turning the workpiece involves six steps-

1. positioning-

The turning machine is ready to accept the collar. Here the two clippers are in vertical orientation and the two turners in opening position, as shown in Figure 4.2 (b).

2. loading-

The robot end-effector loads the unturned collar over the bridge, as shown in Figure 4.2 (c).

3. locating the collar point-

To locate the collar points, the two clippers swivel in opposite directions. During this time the end-effector maintains its hold on the collar, also shown in Figure 4.2 (c).

4. trapping the collar points-

After actuating the air jet and turning the corner ply the collar point is ready for trapping by actuating the turners against the clippers, as shown in Figure 4.2 (d).

5. turning-

Prior to turning the end-effector releases the collar. Figure 4.2 (e) exhibits the turned collar following the turning motion in which the two bridges hold the collar plies and affect the orientation of the collar plies, following the transfer of the collar points through the opening between the bridges. The turned collar is now located between the two bridges' surface.

6. unloading-

Figure 4.2 (f) exhibits the retrieved collar turned with assistance of the end-effector. When the end-effector holds the upper collar ply the two turners actuate to their opening positions.

To complete this step the robot end-effector maneuvers the collar to the pressing station. This station was designed by Kishore Subba-Rao (5).

System Evaluation

The automated procedure was tested with a supply of collars from Clemson Apparel Research (CAR). The loading and turning of the collars proved consistently successful. The

(a): The Destacker Assist the End Effector to Load the Collar

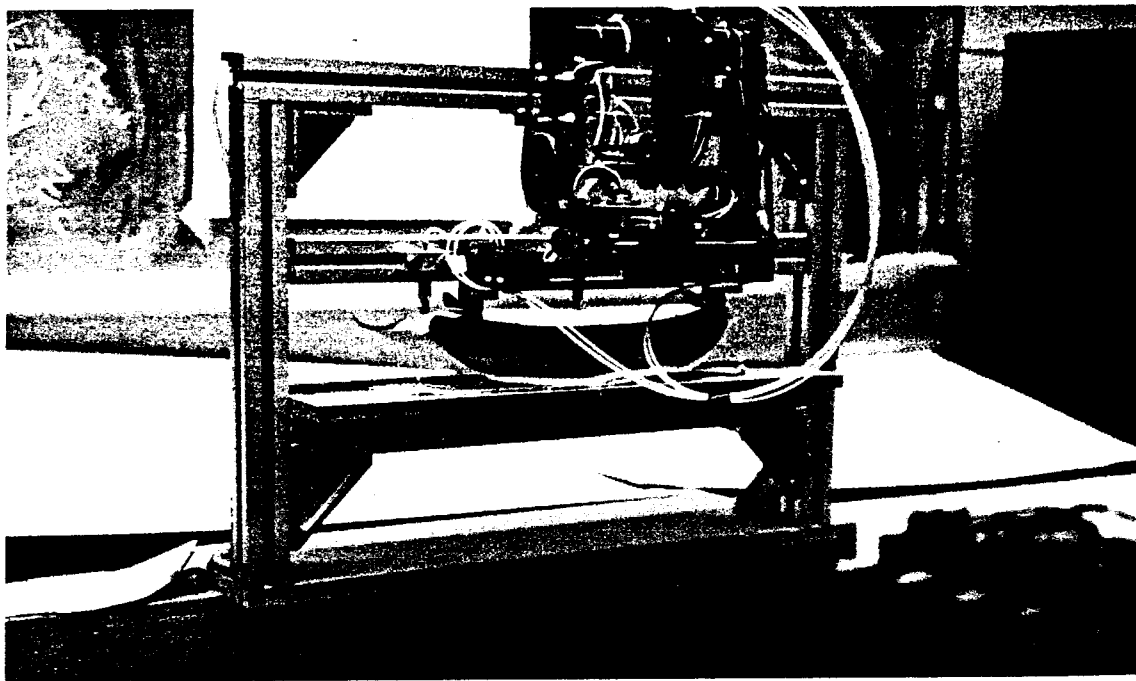

(b): The Turner Machine Ready to Accept the collar

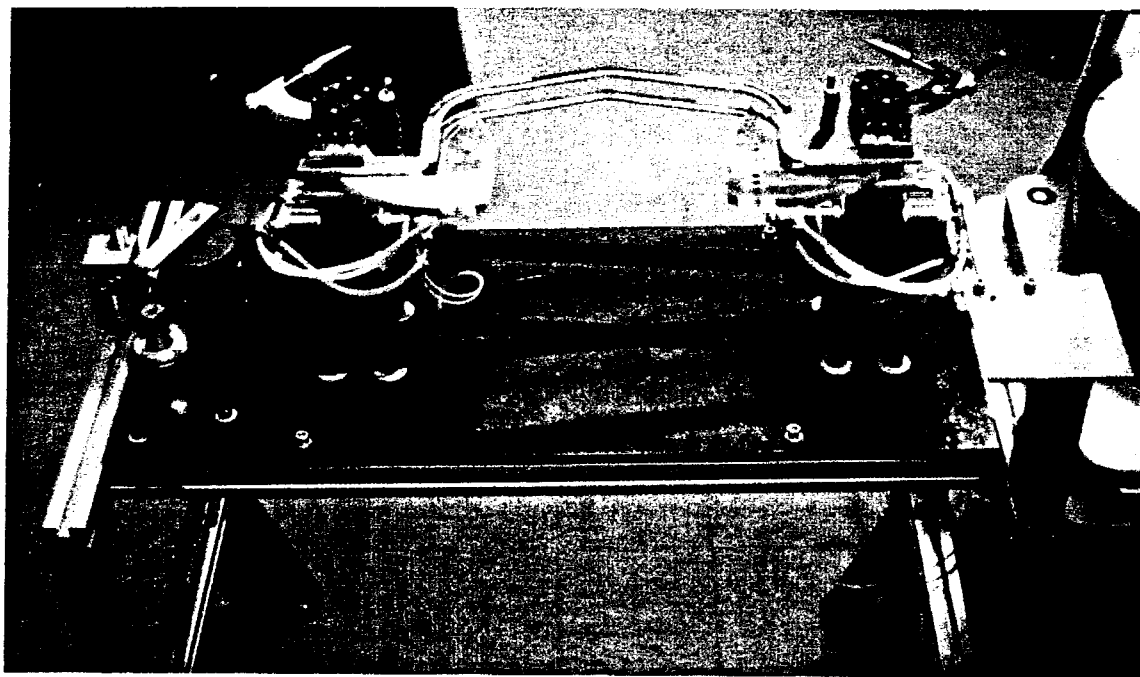
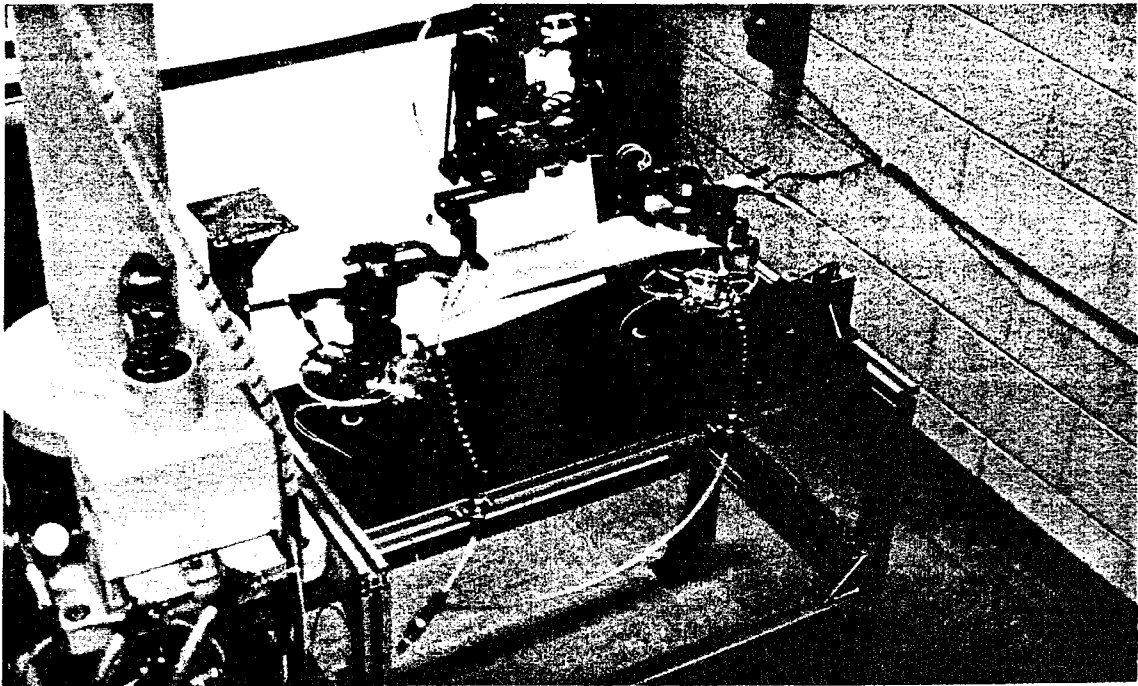

Figure 4.2: Turning Sequence

(c): The Robot Loads the Unturned Collar



(d): Using Air Jet to Trapping the Rigid Ply

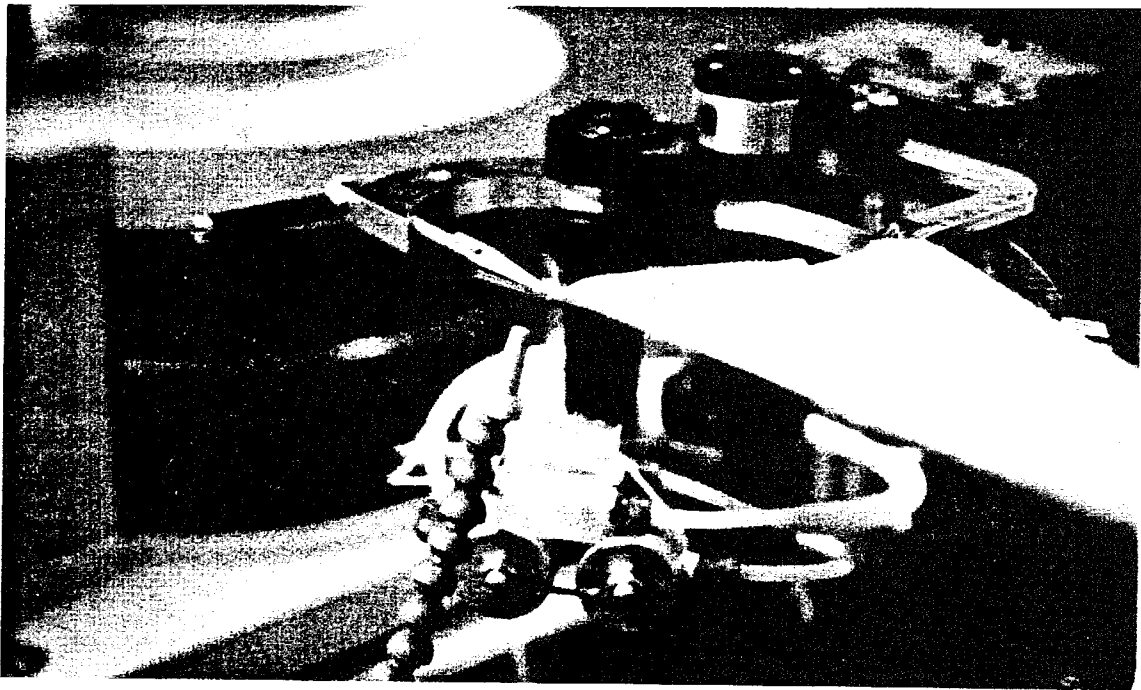
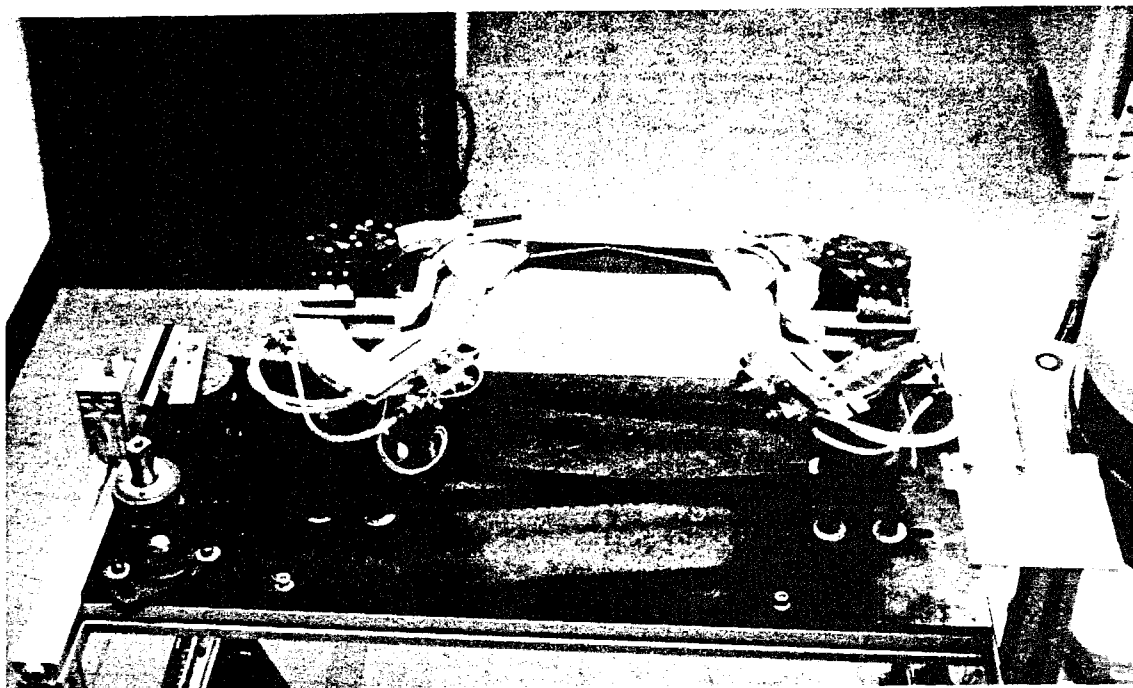

Figure 4.2: Turning Sequence (Continued)

(e): Turning



(f): The End-Effector Holds the Upper Collar Ply

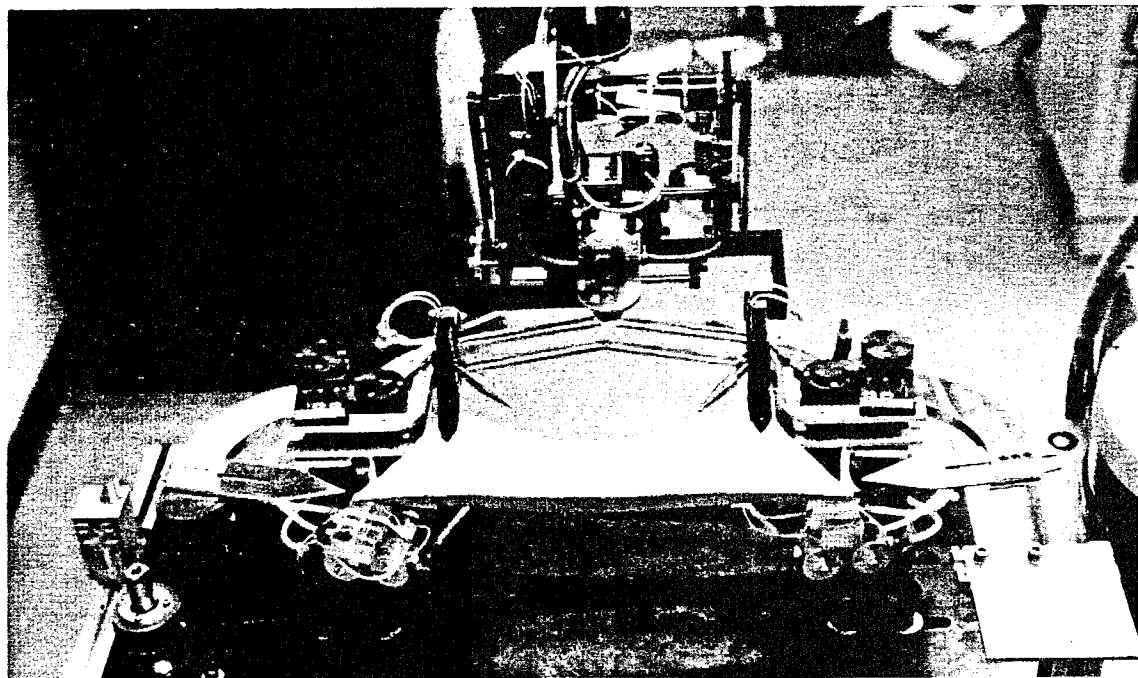

Figure 4.2: Turning Sequence (Continued)

following paragraphs mark some of the problems that were studied in the experiments.

Unloading the Collar from the Turning Machine

Retrieval of the collar from the turner machine proved a difficult operation due to the unpredictable manner in which the unfused collar ply would settle on the upper bridge segment. A number of solutions were examined and one was selected to increase the tension on the collar points for locating the unlined ply which the end-effector grippers retrieved.

Forces Applied on the Collar Seam

In step number three of the turning process the two turner tips apply forces on the collar. It was found that the collar seam shape was changed by these forces.

Figure 4.3 (a) illustrates the collar seam without any forces applied. After applying the force by rotating the two clippers the seam was changed to a straight line, like is shown in Figure 4.3 (b). This change of the seam is not significant to the turning process. After locating the collar point using the cone shape point of the collar, the collar slips over the turners until the collar pocket fits over the turner.

Quality of the Collar Point

To check the quality of the collar point, a comparison was made between turning the collar with the Lunapress and

(a): The Clippers Rotated Around the Pivot Points

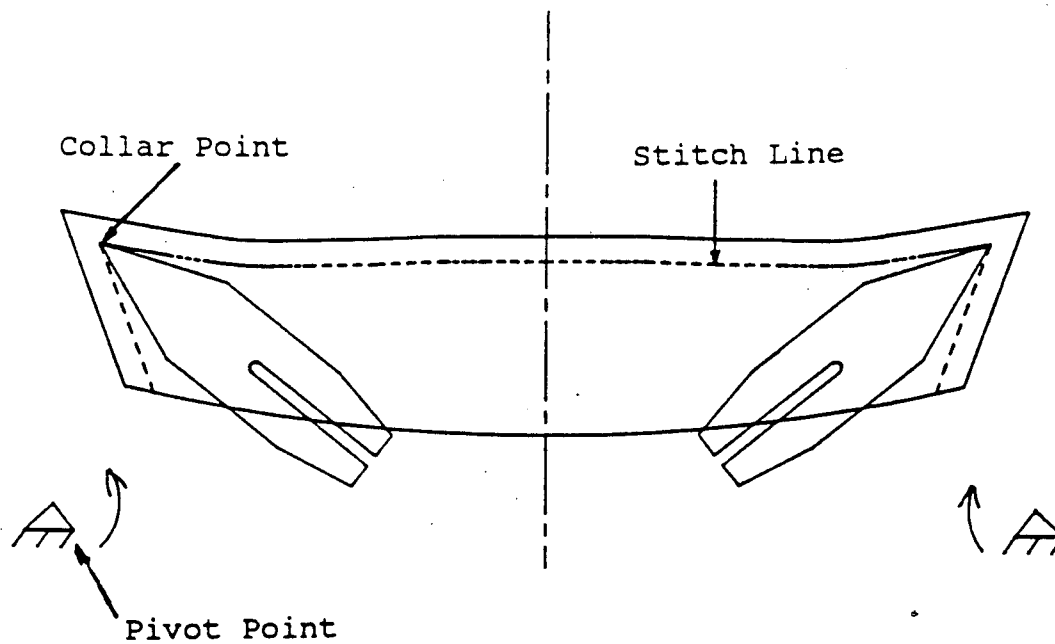

(b): Force Applied On the Collar By the Clippers Edge

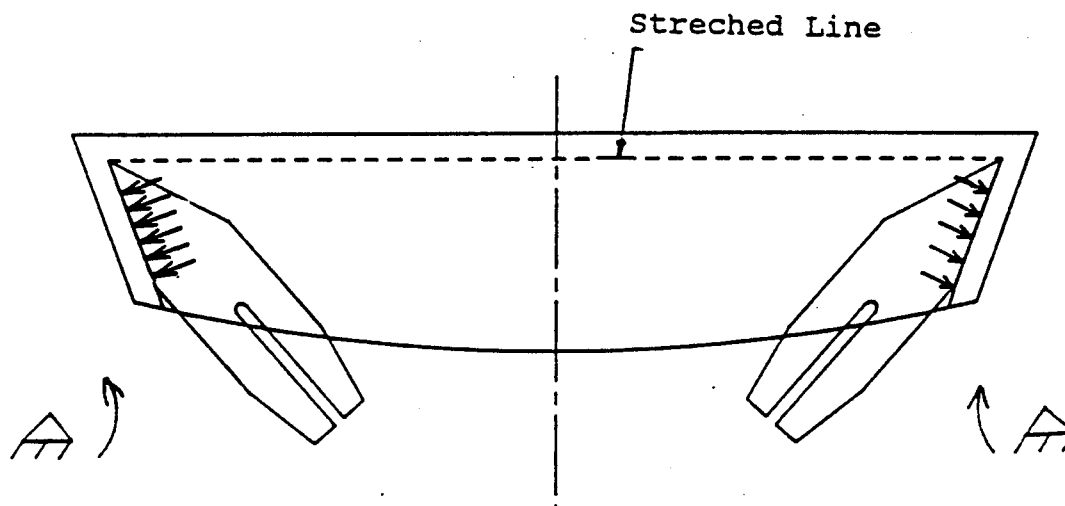

Figure 4.3: Forces Applied on the Collar Seam

turning the collar by a pivot turning machine. In both cases the quality is identical.

Comparison of Pressed Collars

To obtain the best results the comparison between the collar that was turned by the turning machine and the collar turned by the Lunapress must be made after both collars are turned and pressed. Figures 4.4 (a) and (b) are visual comparisons between the two collars. The comparison shows that the quality of both collars is comparable. The trim size must be managed since during the turning operation of the collar point there is not enough space to allow the material to be squeezed. This makes a significant difference in the quality of the collar point after it is pressed.

(a): The Collar Turned and
Pressed On the Lunapress

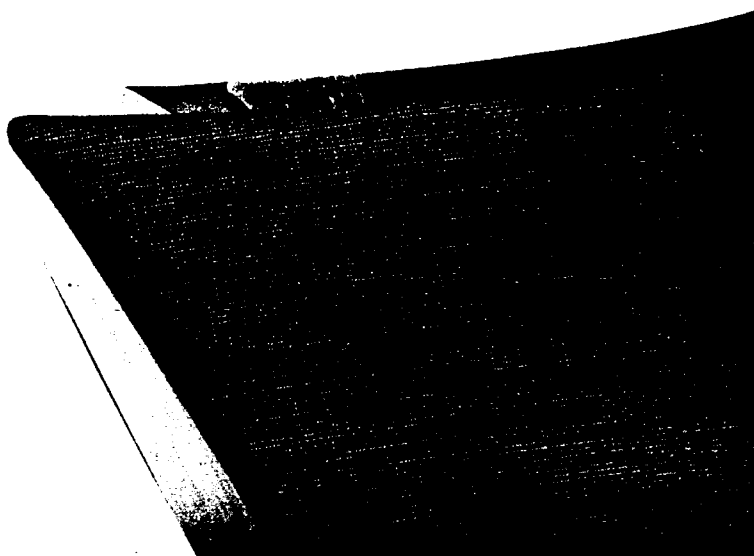

(b): The Collar Turned On the Turner
and Pressed On the Lunapress



Figure 4.4: Quality of the Collar Point

CHAPTER V
A CONCEPT FOR INTEGRATION OF THE TURNING
AND PRESSING PROCESSES

Manual Pressing Operation

Before presenting the integration of the Turning and Pressing, it is important to understand the manual pressing operation. Figure 5.1 presents the sequence of manual pressing. The operator uses two rigid templates such that the collar seam aligns perfectly with the template's edge. This operation is critical to the quality of the finished collar. The alignment is done by the operator rolling the seam over the template's edge. The template is then actuated into the pressing die as shown in Figure 5.1.

Concept Integration

The proposed integration of turning and pressing of the collar from the turning station could eliminate:

- (i) Transport of the collar to the pressing machine.
- (ii) Loading of the collar on the pressing machine.

These actions could result in a significant increase in productivity and could simplify the process. In the turning machine, the two C-shaped brackets hold clippers and a turners pair, and swivel in opposite directions about two pivot points. It is proposed to replace the two turners with two

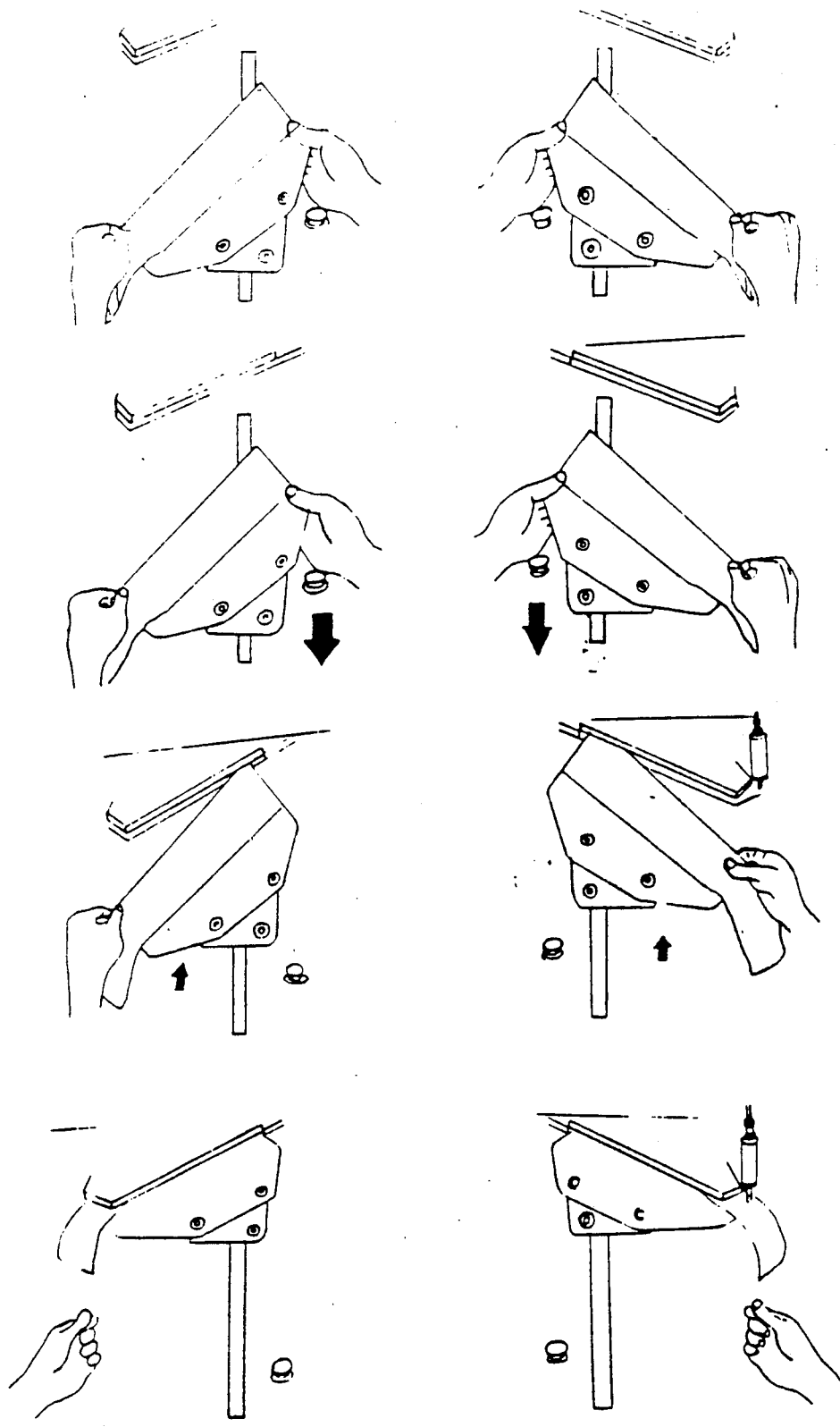

Figure 5.1: Pressing Sequence

flat metal blades, whose shape is similar to the pressing blade design on the Lunapress.

A representation of the proposed device is shown in Figure 5.2 (a). The point at the tip of the flat blade traps the collar point against the clipper performing the same function as the original turner. The distance between the two brackets holding the clippers and the pressing blades can be manually adjusted for different collar sizes. As the collar is turned, the pressing blades pass through the two collar plies. Figures 5.2 (a) through (d) describe the collar inversion sequence for the modified turner machine. At the end of the turning sequence, it is proposed to perform the seam alignment as discussed in the following paragraphs.

Automatic Seam Alignment

The collar is made of two plies with different stiffness. In the turning process the two plies are rotated 180 degrees around the seam line. In the Lunapress machine a template is used to break the seam line of the ply with the larger stiffness. This line breaks along the seam edge.

Two ideas for automating the seam alignment are presented:

1. Two Clamping Plates in Linear Motion

Two clamping plates each have an edge profile matching the collar seam. The collar is then clamped before the turning process begins as shown in Figure 5.3 (a). The

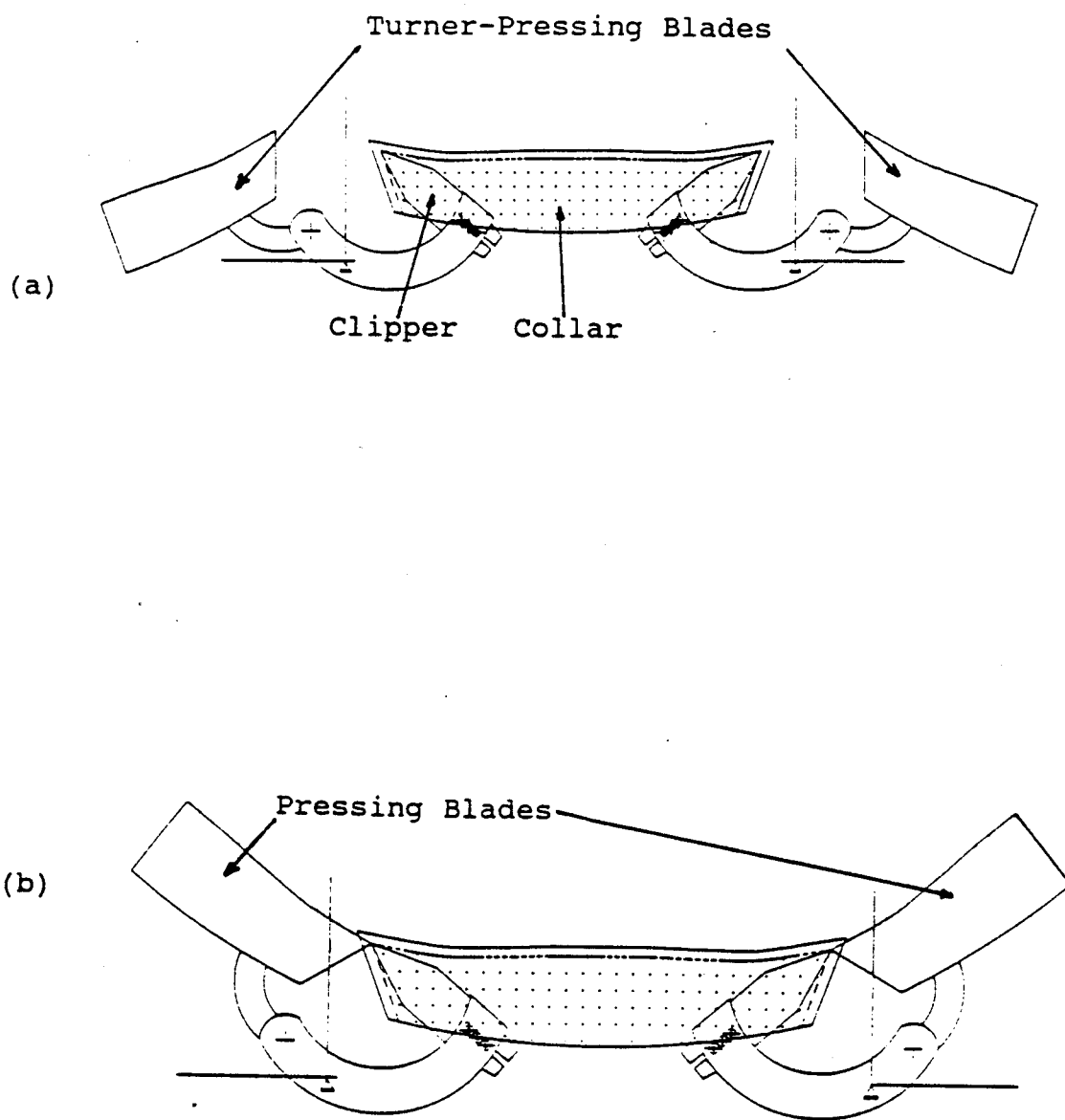
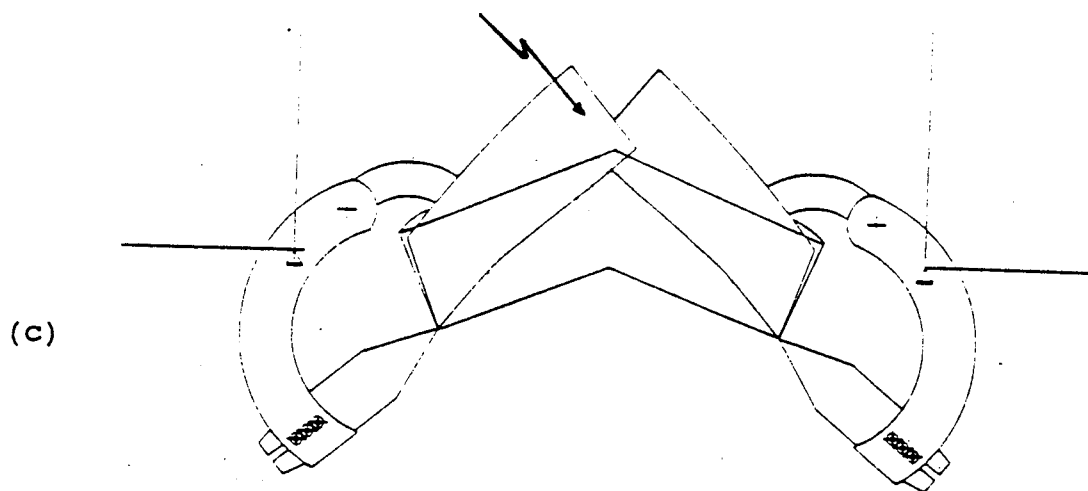

Figure 5.2: Integration of the Turning and Pressing Operation

Interference Between the
Two Pressing Blades



The Pressing Blades Enter
Between the Two Clilar Plies

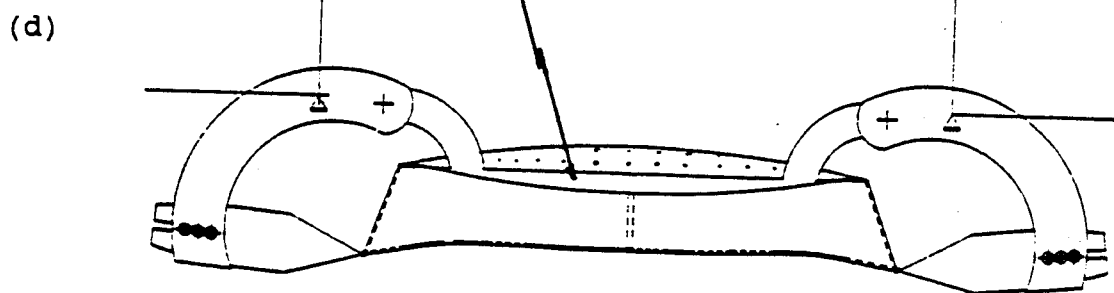

Figure 5.2: Integration of the Turning and Pressing Operation
(continued)

edges of the clamping plates are mirror images of the collar seam. The collar is turned with the clamping plates moving with a linear motion into the collar pocket while the turning takes place. After turning, the collar seam and the clamping plate edges match. The principle is similar to that of the pivot turning process and is illustrated in Figure 5.3 (b) and (c). After the turning is complete, the collar is pulled against the clamping plates. In this movement, automatic seam alignment is achieved.

2. Two Clamping Plates in Pivoting Motion

Before the collar is turned, the seam can be located because the collar is flat. The ply with the higher stiffness is then clamped with the two clamping plates that have the same edge profile as the collar seam as shown in Figure 5.4 (a). The collar is turned with the clamping plates having a pivoting motion as shown in Figures 5.4 (a) through (d). After turning, the collar seam is aligned against the clamping plate edges.

Evaluation

To evaluate the concept, a prototype was built and tested. The resulting collar seam edge was satisfactory as shown in Figure 5.5. This method is suggested for seam alignment.

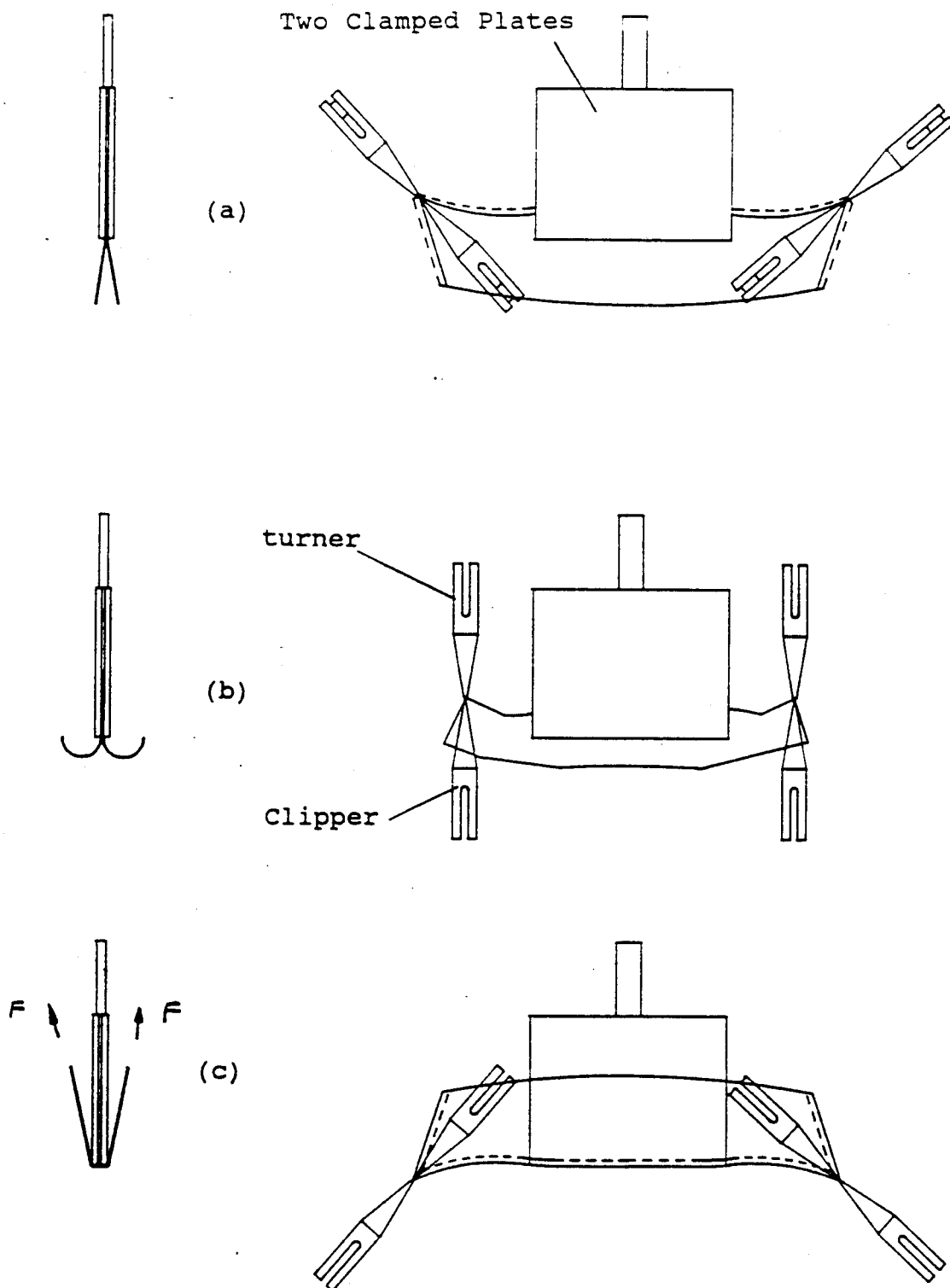

Figure 5.3: Two Clamped Plates - Linear Motion

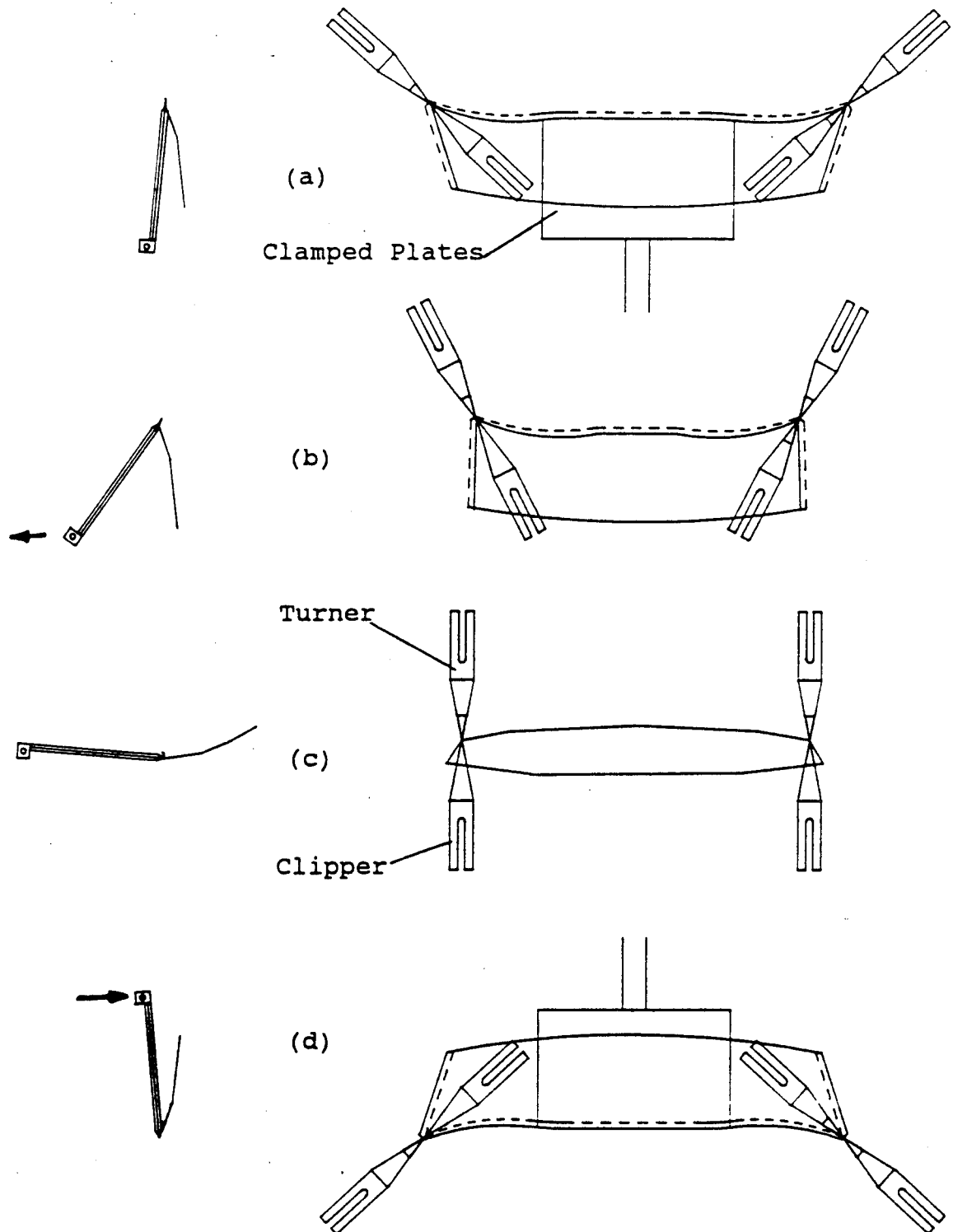
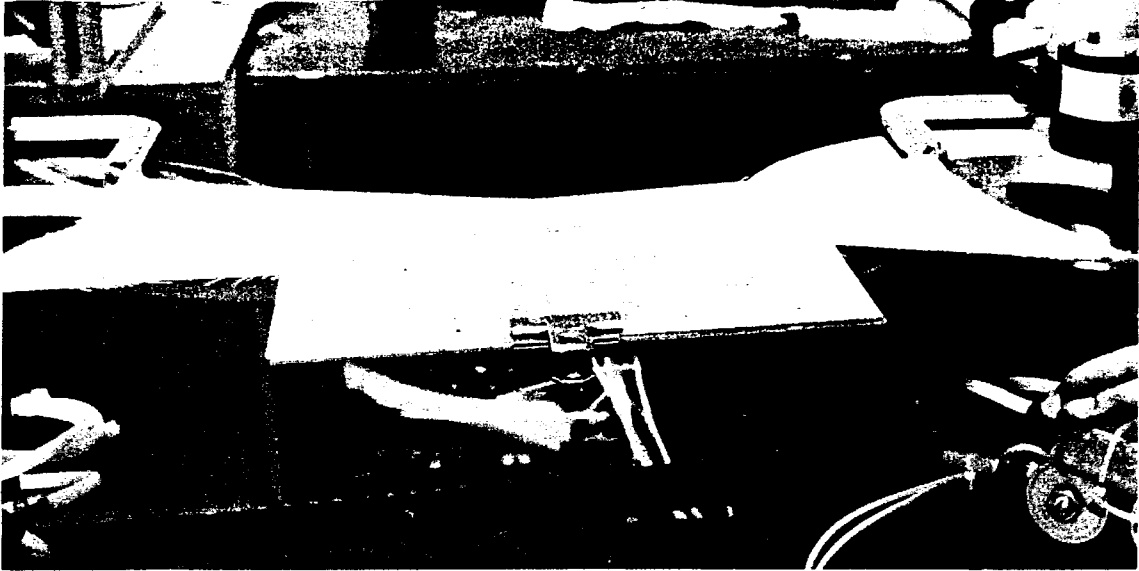

Figure 5.4: Two Clamped Plates - Pivoting Motion

(a): The Two Plates Clamping the Collar



(b): The Collar Seam Edge

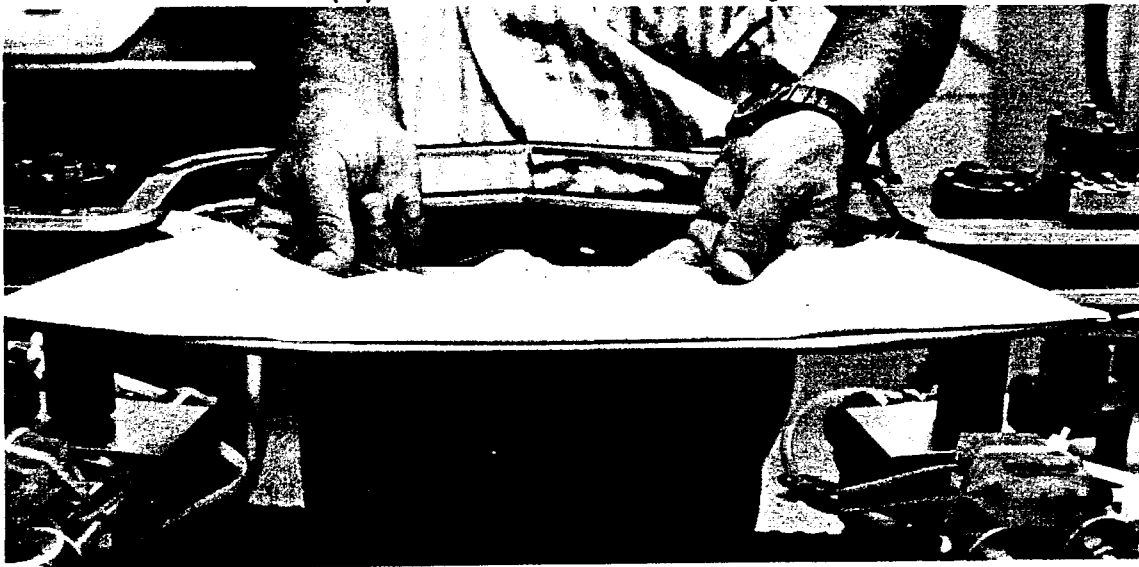

Figure 5.5: Test of the Automatic Seam Alignment

CHAPTER VI

CONCLUSION AND RECOMMENDATIONS

Conclusion

Double-point pivot turner

The turner machine comprises two C-shaped brackets, each featuring a clipper and turner pair. The C-shaped brackets swivel in opposite directions about two pivot point shafts. To secure the collar point between clipper and turner, the C-shaped bracket opens to accept the collar and allow the end-effector to simultaneously position the collar on the bridge. The laboratory experiments show that it is feasible to turn collars with satisfactory quality using the proof-of-concept turning machine. The machine is functionally capable of turning different sizes of collar. A possible cost reduction can be achieved by using an cylinder air as a drive unit.

Integrated With a Robotic Apparel Assembly Workstation

The pivot turner was integrated with a robotic apparel assembly workstation, and successfully used to load and unload collars from the turner machine. The demonstration showed the feasibility of robot assisted apparel manufacturing.

Integration Double-Point turning and Pressing

The concept for integrated double-point turning and pressing that was described in Chapter V could result in a significant increase in productivity and could simplify the process by eliminating the following process steps.

1. Transport of the collar to the pressing machine.
2. Loading of the collar in the pressing machine
3. Locating the collar points by the creaser blade..
4. Reduction of the cycle time.

Recommendations

Torque Sensing

The laboratory research shows that the collar size varies in every collar batch. This is a result of setup errors during the seam sewing process. As a result the distance between the two collar points varies by approximately 1 mm. This change of collar distance requires a change in the angles of the C-shape brackets' rotations. To achieve a good quality collar point this can be solved by utilizing a method for detecting collar tensions by force or torque.

Loading and Unloading Without the Robot

To reduce cost, the robot may be eliminated to load the collar in the turner machine. Instead, an operator or "pick-and-place" mechanism could load and unload the collar.

Ply Separation Device

Loading and unloading the collar requires a device for gripping the collar. Currently, several devices are available that are capable of this operation. Such a device would permit gripping the upper collar ply from the collar pile and eliminate the need to design a ply separator as done on this project.

APPENDICES

Appendix A
KINEMATIC AND DYNAMIC MODELING OF
A MODIFIED TURNER MACHINE

Introduction

The demand for a commercial machine that is able to turn different sizes and styles of collars is the major reason behind the decision to develop a kinematic and dynamic model that can be used for future designs machines. Since the commercial machine needs to turn different collar sizes and styles, the angle of rotation will vary. Input to the program includes collar parameters where the output is the angle of rotation of each link.

Modified Turner Machine Motion

The kinematic mathematical models developed used kinematic equations for several links. Arbitrary frames fixed to the links are used to describe the position and orientation of each link. The turner machine has a base link connected to the ground, as shown in Figure A.1. Since the turning machine is symmetric about line a-a in Figure A.1, only the right side of the machine is considered. Link 2 drives the system and is connected to the drive unit, while the C-Shape Bracket is link 4 as shown in Figure A.1. The link that is connected between the drive link and the C-Shape Bracket is numbered as link 3.

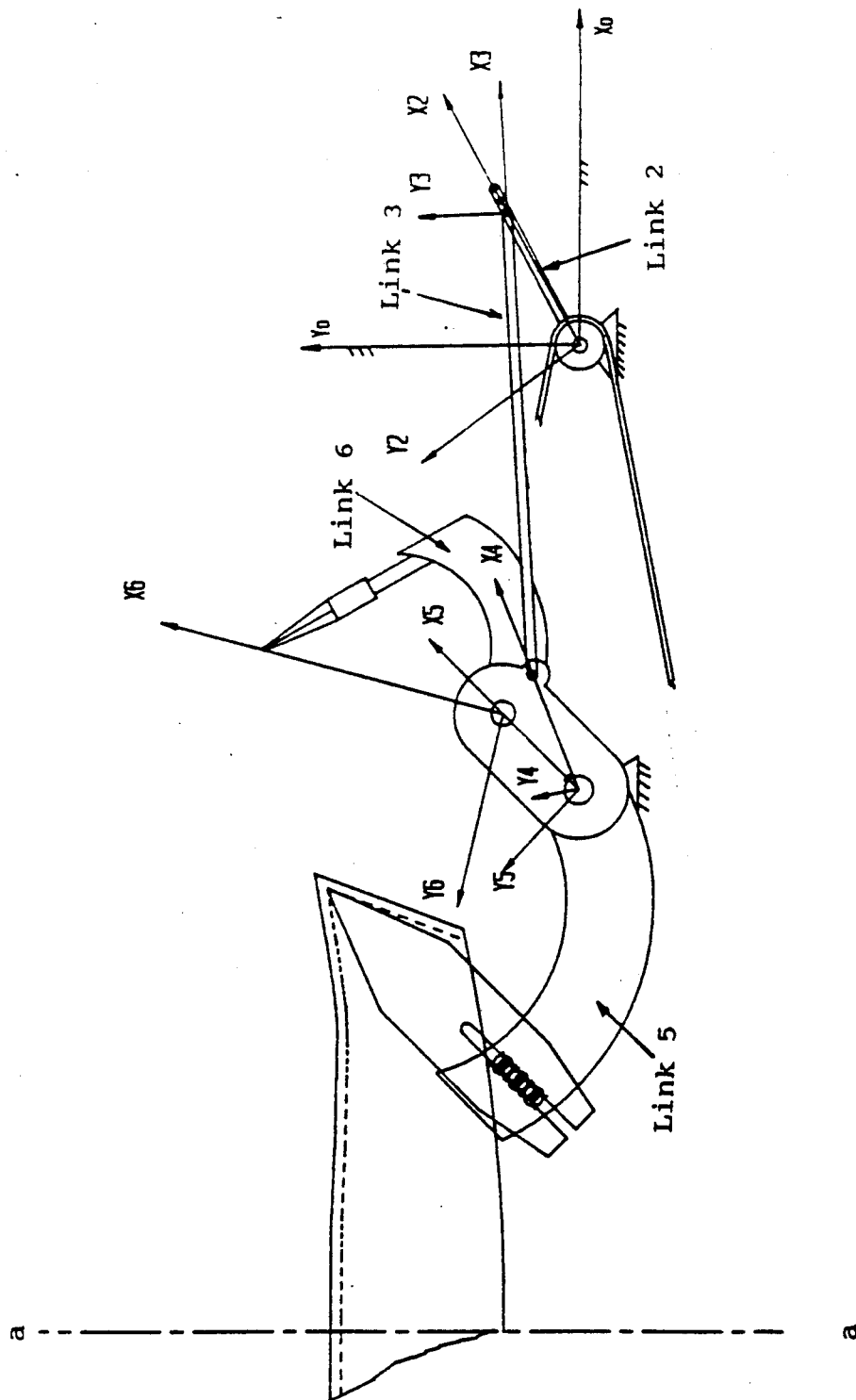

Figure A.1: Coordinated Frame Fixed to the Links

The coordinate frame {4} is fixed to the C-Shape Bracket. Link 5 and link 6 have coordinate frames referenced to frame {4}. This orientation allows the definition of the center of gravity and inertia of link 4 in several turner positions. Since the center of gravity and inertia are functions of the turner orientation, this implies that the center of gravity and inertia for link 4 can be determined by studying the position and orientation of each link member in frame {4}.

Drive Unit Link Parameters

Vector and Joint Locations

Figure A.2 describes the vector locations of the right side of the system collar turner. The joints allow relative motion between the following links.

Joint Locations:

- joint 0: Revolute joint that allows the input rotation of right side of the drive unit.
- joint 1: Revolute joint that allows relative rotation of the right side of the C-Shape Brackets.
- joint 2: Revolute joint that allows relative rotation between link 2 and link 3.
- joint 4: Revolute joint that allows relative rotation between the left C-Shape Bracket and link 3.
- point 5: Revolute joint that allows relative rotation between the clipper arm link 6 and link 5.

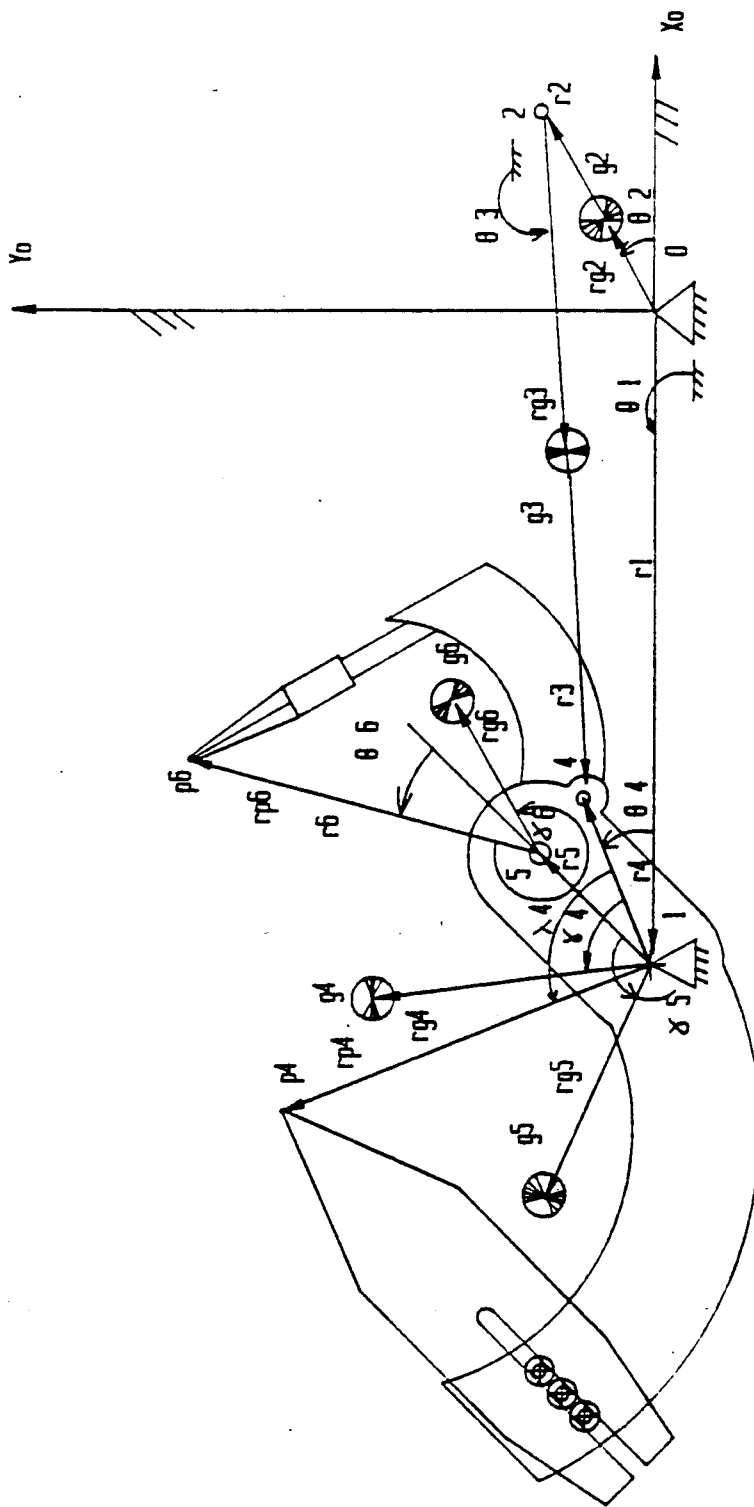

Figure A.2: Vector Location of the Right Side

Vector Locations:

The following vectors describe the joint location on the left side of the system:

- vector r_1 : vector from joint 0 to joint 1.
- vector r_2 : vector from joint 0 to joint 2.
- vector r_3 : vector from joint 2 to joint 4
- vector r_4 : vector from joint 1 to joint 4.
- vector r_5 : vector from joint 1 to joint 5.
- vector r_6 : vector from joint 5 to the tip of the turner.

The magnitude and angle of vector locations are described in Figure A.2 and in Table A.1.

Table A.1: Magnitude and Angle of Vector Locations.

Vector	r_0	r_1	r_2	r_3	r_4	r_5	r_6
[in]	20.3	9	3	10	2.17	2.17	5
[mm]	516	228.	76.2	254	55.1	55.1	127
[deg]	0	180	θ_2	θ_3	θ_4	θ_5	θ_6

Parameters of Link 4

The center of gravity and the moment of inertia of link 4 can be determined by investigating the position and orientation of each link member in frame {4}, as shown in Figure A.3. Link 5 and link 6 are two link members that are referenced to frame {4}. The center of gravity and the moment of inertia of link 4 can be described in several turner orienta-

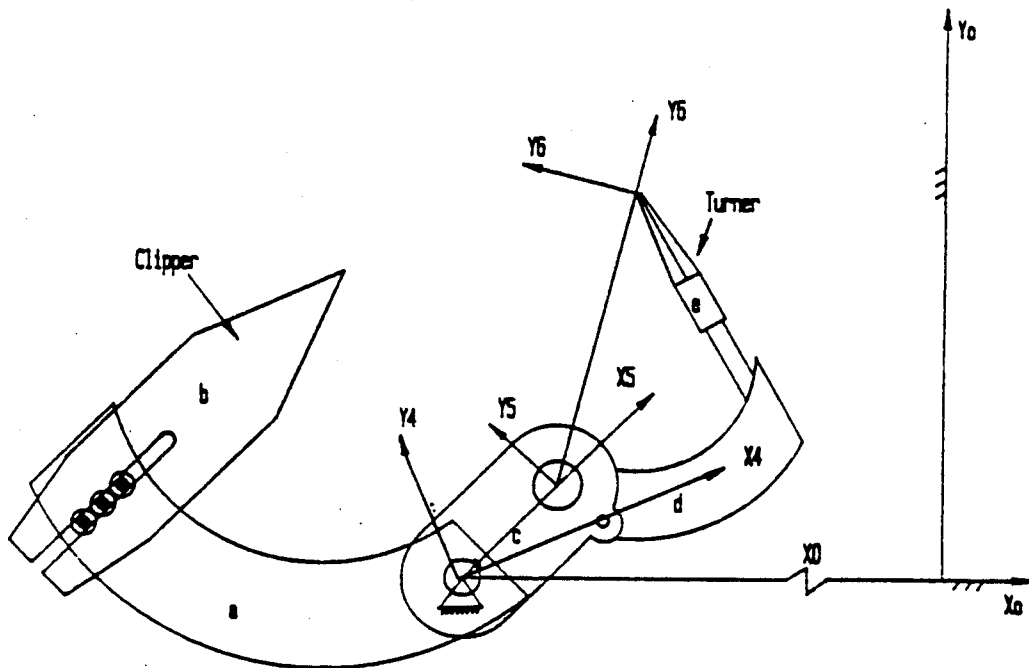

Figure A.3: Location of the Coordinated Frame on the C-Shaped Bracket

tions since those parameters are functions of the turner orientation.

Location of Center of Gravity

Each link is represented as a point mass. The vector r_{gi} locates the mass center from each joint. We can write the following vectors to describe the location of the centers of gravity.

r_{g2} : vector from joint 0 to the center of gravity g2.

r_{g3} : vector from joint 2 to the center of gravity g3.

r_{g4} : vector from joint 1 to the center fo gravity of the C-Shape Bracket. The vector is function of the position of the C-Shape Bracket.

r_{g5} : vector from joint 1 to the center of gravity g5.

r_{g6} : vector from joint 5 to the center of gravity g6.

The vectors are shown in Figure A.2 and Table A.2 describes the magnitude and the angle of rotation.

Table A.2 : Magnitude and Angle Location of Vector r_g .

Vector	r_{g2}	r_{g3}	r_{g4}	r_{g5}	r_{g6}
[in]	1.5	5	*	3.7	1.99
[mm]	38.1	127	*	93.98	50.55
θ [deg]	0	0	*	106.2	5

* vector r_{g4} are a function of a turner orientation.

Vector Locations of External Forces that Act on the Links

Points p_4 and p_6 in Figure A.2 define the location of external forces that act on the links 4 and 6, and vector r_{p_i} marks the distance from the joint to point p_i of external force location. Since the external force acts only on links 4 and 6, the following vectors describe the locations of point p_i for those links:

r_{p_4} : vector from joint 1 to external link 4 force point.

r_{p_6} : vector from joint 5 to external link 6 force point.

The vectors are shown in Figure A.2, and Table A.3 describes the magnitude and angle of rotation.

Table A.3: The Magnitude and Angle Location of Vector r_{p_i} .

Vector	r_{p_4}	r_{p_6}
[in]	5.45	5
[mm]	138.43	127
[deg]	66.69	0

Kinematics Modeling

Methods of Velocity and Acceleration Analysis

Three methods for determining the velocity and accelerations in mechanisms are :

1. analysis using vector mathematics to express the velocity and acceleration of a point with respect to a moving and fixed coordinate systems,

2. analysis using equations of relative motion which are solved either analytically or graphically using velocity and acceleration polygons, and
3. analysis by using vector loop closure equations written in complex form.

The first and the third methods lend themselves to computer solutions, which is a decided advantage if a mechanism is to be analyzed for a complete cycle. This analysis used the vector loop approach from kinematics, for designing the modified turner motions.

A simple kinematic case is shown in Figure A.4 (a) with rotating link 2 about fixed axis O_2 . The positions of point p are represented by vector r_p as shown in Figure A.4 (b). The vectors r_p are often used for examples expressed in complex form has:

$$\begin{aligned} r_p &= a + ib \\ r_p &= r_p(\cos\theta_2 + i \sin\theta_2) & (A.1) \\ r_p &= r_p e^{i\theta_2} \end{aligned}$$

Although all forms of the complex number are useful, the simplest form for differentiation is the exponential form in which:

$$\begin{aligned} r_p & \text{ is the magnitude of the vector} \\ 1e^{i\theta_2} & \text{ represents a vector of unit length at a counter-} \\ & \text{clockwise angular position } \theta_2. \end{aligned}$$

The velocity vector V_p presented in Figure A.4 (c) is obtained by differentiating equation (A.1) giving

$$V_p = d/dt(r_p) = r_p \theta_2 i e^{i\theta_2}$$

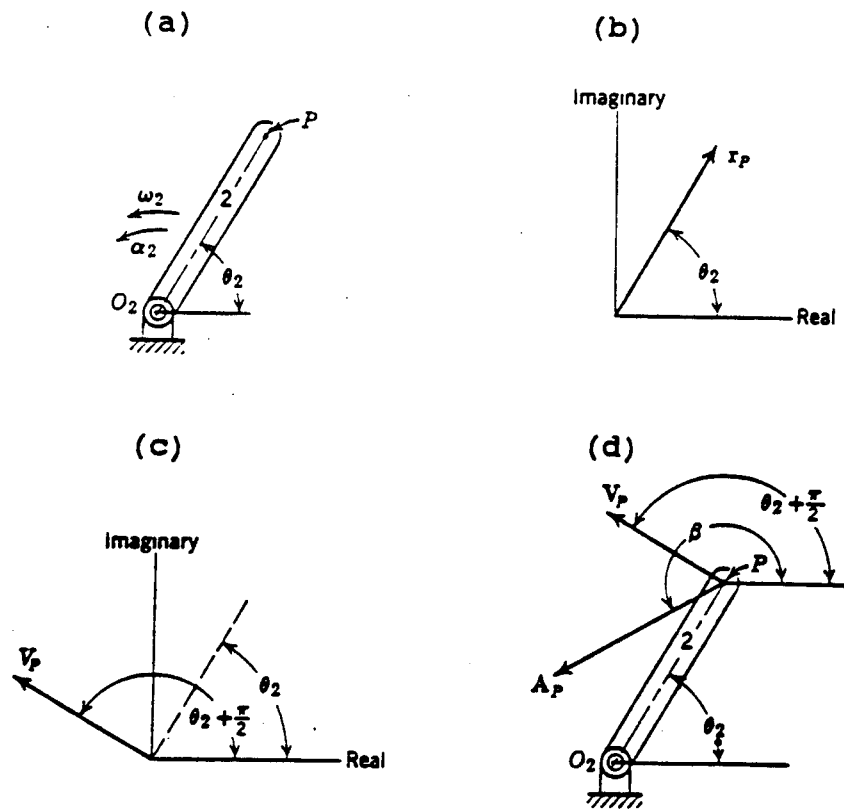

Figure A.4: Rotating Link [3]

By using trigonometric relationships, it may be shown that

$$i(\cos\theta_2 + i \sin\theta_2) = \cos(\theta_2 + \pi/2) + i \sin(\theta_2 + \pi/2) = e^{i(\theta_2 + \pi/2)}$$

and

$$v_p = d/dt(r_p) = r_p \dot{\theta}_2 e^{i(\theta_2 + \pi/2)}$$

$$v_p = r_p \dot{\theta}_2 e^{i\pi/2} \quad (A.2)$$

The direction of the velocity vector v_p is shown to be at an angle 90° greater than the angle of r_p . The acceleration vector A_p as presented in Figure A.4 (d) is given by differentiation of equation (A.2)

$$A_p = d^2/dt^2(r_p) = r_p \omega_2^2 (i^2 e^{i\theta_2}) + r_p \alpha_2 (i e^{i\theta_2})$$

in which:

$d\theta_2/dt = \omega_2$ is the angular velocity.

$d\omega_2/dt = \alpha_2$ is the angular acceleration.

$r_p \omega_2^2$ is the magnitude.

$i^2 = -1$ indicates that the direction is 180° greater than θ_2 .

$r_p \alpha_2$ is the magnitude of the tangential component.

i indicates that the direction is 90° greater than θ_2 .

Equation of Motion

The following equations were developed to kinematically analyze the modified turner machine by using the vector loop close equation written in complex form. The analysis is performed by using equations of relative motion with respect to moving link frames and a fixed coordinate system.

1. Finding positions of r_3 and r_4 (Figure A.2):

In position analysis the links' lengths are r_1 , r_2 , r_3 and r_4 are known, where the objective is to define angles θ_3 and θ_4 for a given value of θ_2 .

The closed loop equation :

$$r_2 + r_3 = r_1 + r_4 \quad \text{or:}$$

$$r_1 + r_2 \cos \theta_2 - r_3 \cos \theta_3 - r_4 \cos \theta_4 = f_1(\theta)$$

$$r_2 \sin \theta_2 - r_3 \sin \theta_3 - r_4 \sin \theta_4 = f_2(\theta)$$

Note that the above equation will be satisfied only for those particular values of θ_3 and θ_4 that close the mechanism loop. The values are often called the root of the equations. This implies that for any value of θ_3 and θ_4 other than the roots those equations will not be satisfied.

Finding the root of those equations is now equivalent to finding the value of θ_3 and θ_4 . It can be said that $f_1(\theta)$ and $f_2(\theta)$ are simultaneously equal to zero.

2. Finding velocity of r_3 and r_4 (Figure A.2):

$$r_2 + r_3 = r_1 + r_4$$

$$r_2 e^{i\theta_2} + r_3 e^{i\theta_3} = r_1 e^{i\theta_1} + r_4 e^{i\theta_4}$$

$$\text{since } \dot{r}_2 = 0, \dot{r}_3 = 0, \dot{r}_1 = 0, \dot{\theta}_1 = 0$$

$$d/dt (r_2 e^{i\theta_2} + r_3 e^{i\theta_3}) = d/dt (r_1 e^{i\theta_1} + r_4 e^{i\theta_4})$$

$$r_2 (\dot{\theta}_2) e^{i(\theta_2 + \pi/2)} + r_3 (\dot{\theta}_3) e^{i(\theta_3 + \pi/2)} = r_4 (\dot{\theta}_4) e^{i(\theta_4 + \pi/2)}$$

$$r_2 (\dot{\theta}_2) + r_3 (\dot{\theta}_3) = r_4 (\dot{\theta}_4) \quad (\text{A.3})$$

3. Finding velocity of g_2 and g_3 :

Velocity of point mass g_2 :

$$r_{g2} = r_{g2} e^{i(\theta_2 + \gamma_2)}$$

$$d/dt(r_{g2}) = r_{g2}(\dot{\theta}_2) e^{i(\theta_2 + \gamma_2 + \pi/2)} = r_{g2} e^{i(\theta_2 + \gamma_2)} (\dot{\theta}_2) e^{i\pi/2}$$

$$v_{g2} = r_{g2}(\dot{\theta}_2) e^{i\pi/2}$$

velocity of mass g3:

$$r_{g3} = r_2 + r_{g3}$$

$$v_{g3} = d/dt[r_{g3}] = d/dt[r_2 e^{i\theta_2} + r_{g3} e^{i(\theta_3 + \gamma_3)}]$$

$$= r_2(\dot{\theta}_2) e^{i(\theta_2 + \pi/2)} + r_{g3}(\dot{\theta}_3) e^{i(\theta_3 + \gamma_3 + \pi/2)}$$

$$= r_2(\dot{\theta}_2) e^{i\pi/2} + r_{g3}(\dot{\theta}_3) e^{i\pi/2}$$

$$v_{g3} = [r_2(\dot{\theta}_2) + r_{g3}(\dot{\theta}_3)] e^{i\pi/2}$$

Solving by TK Solver

The kinematic model was solved using TK Solver software. The model was designed to calculate the turning operation through the input link motion. Link 2 is the link which imposes displacement, velocity and acceleration on the system as described by the above kinematic model.

Program Input

1. Driving Input:

The driving input is a sinusoidal acted

$$t_2 = 62.5 - 56.5 * \text{sind}(t * 2 * \text{pi} / 2)$$

$$t_2d = -56.5 * (2 * \text{pi} / 2) * \text{cosd}(t * 2 * \text{pi} / 2) / 57^2$$

$$t_2dd = 56.5 * (2 * \text{pi} / 2)^2 * \text{sind}(t * 2 * \text{pi} / 2) / 57^3$$

2. Cycle Time:

The cycle time varies from 4.8 second to .48 second as discussed in Chapter 3. It is possible to determine the speed of rotation of the stepper motor

using the PC computer and the DCX controller board. The turner machine currently operates with a 2 second cycle time. The kinematics model that was computed using TK Solver was also designed to use a 2 second cycle time.

Results kinematics

1. Link Positions:

Figure A.5 shows the output of position of links 3,4,5 and 6 during one cycle of the turner. Link 2 is the input link with the specified position on the system.

2. Link Velocities:

Figure A.6 describes the output of velocities of links 3 and 4 during one cycle of the turner. Link 2 is the input link and imposes the velocity on the system.

3. Distance Between the Two Clipper Tips:

Figure A.7 describes the distance between the two clipper tips. This parameter will be useful in providing the amount the collar will be stretched.

4. Position and Velocity of the Clipper Tips:

The investigation of the position and velocity of the clipper tips is important since the collar points are held by the two clipper tips during the turning process. Figures A.8 and A.9 describe the position velocity and acceleration of the clipper tips.

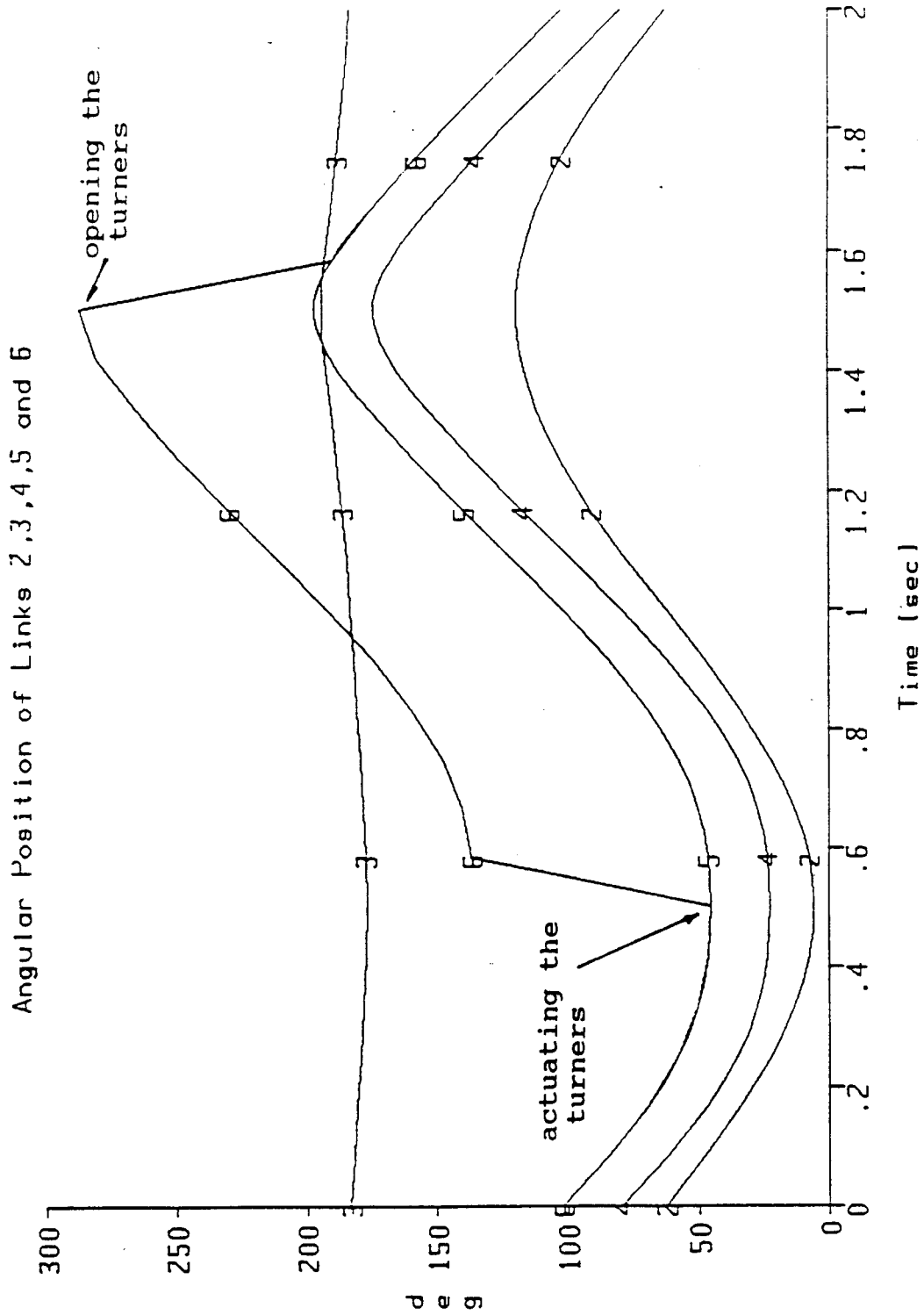

Figure A.5: Angular Position of Links 3, 4, 5, and 6

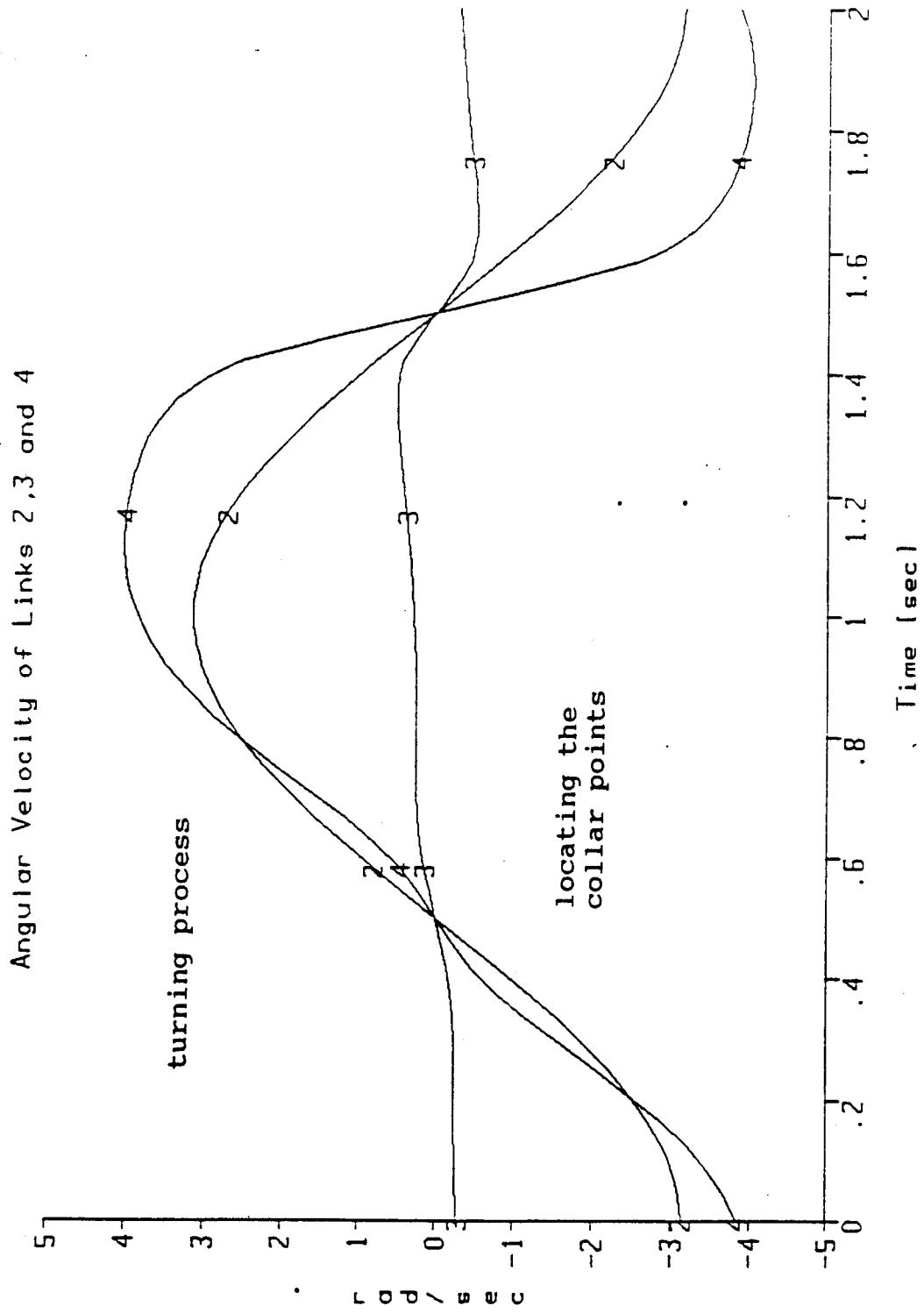

Figure A.6: Angular Velocity of Links 2, 3, and 4

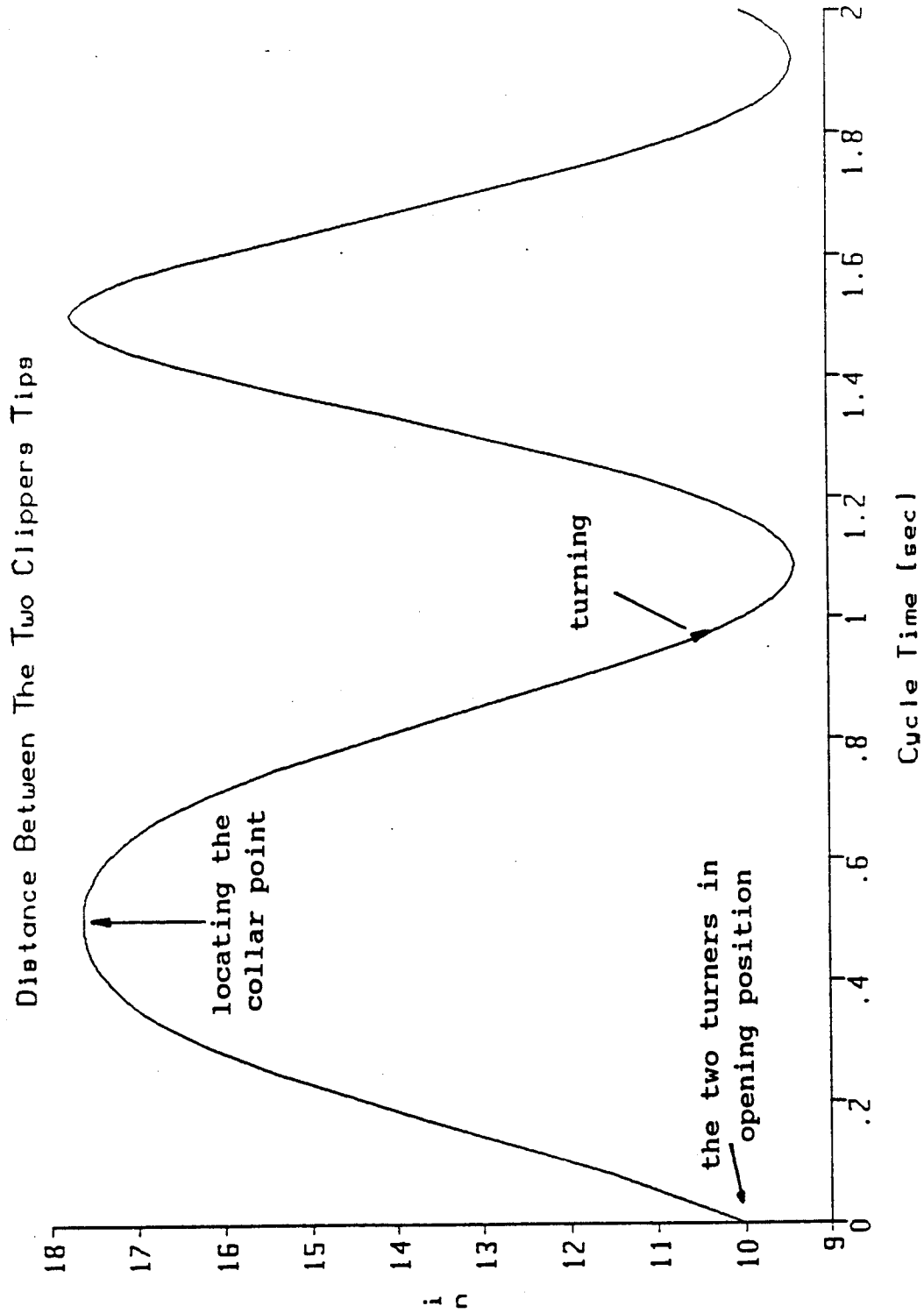

Figure A.7: Distance Between the Two Clippers Tips

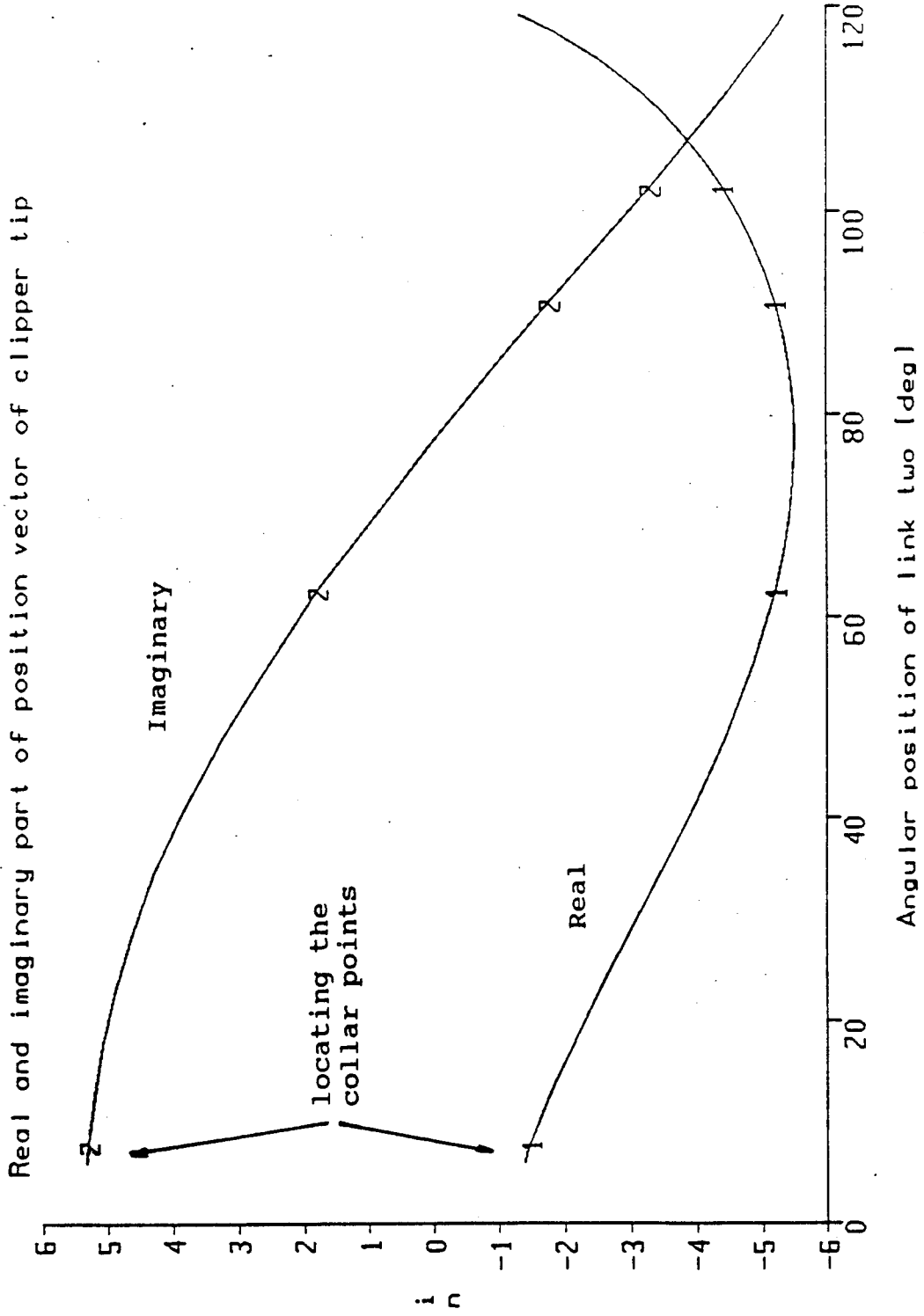

Figure A.8: Real and Imaginary Parts of Position Vector of Clipper Tip

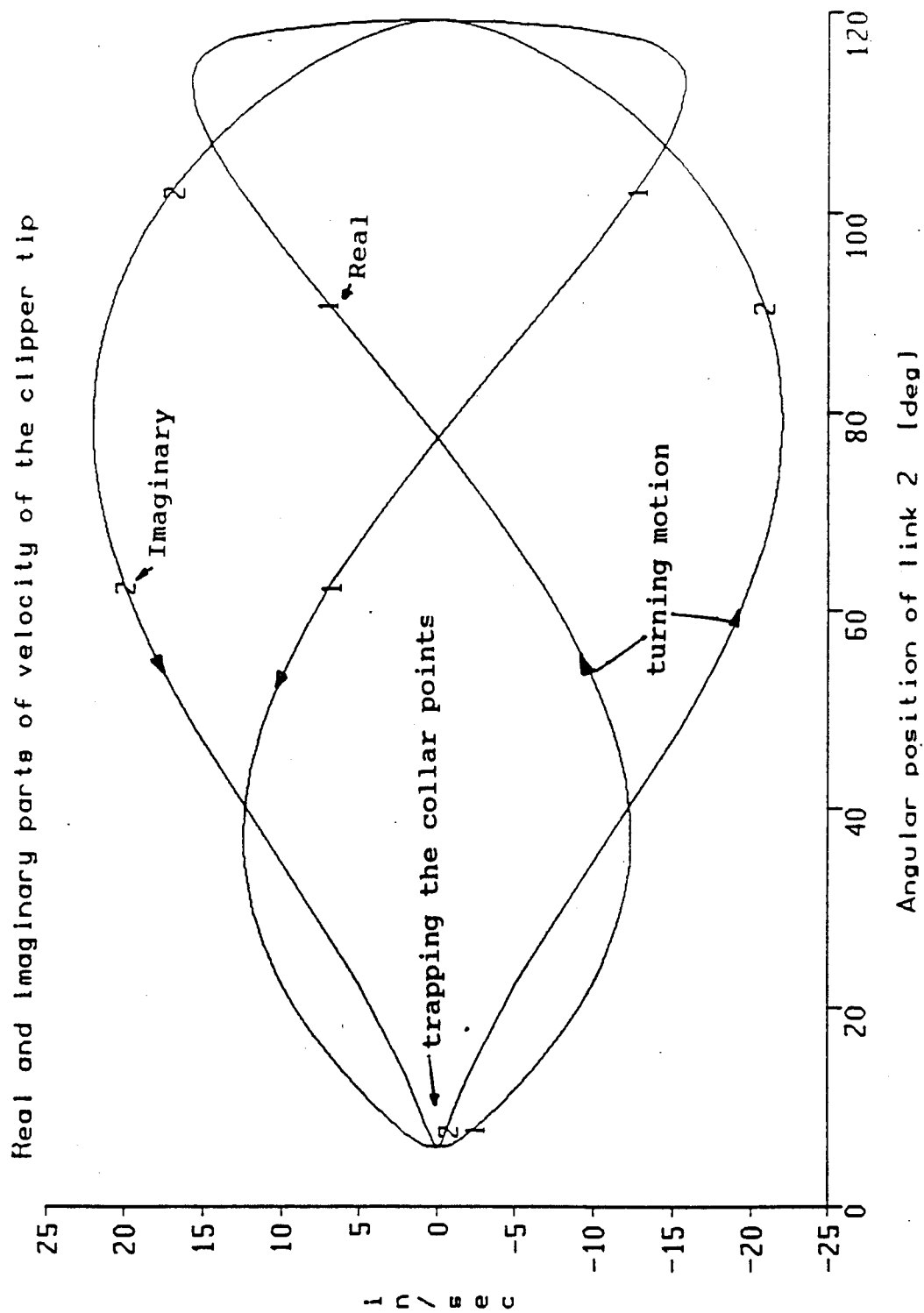

Figure A.9: Real and Imaginary Parts of Velocity of the Clipper Tip

Dynamic Modeling

Inertia Force and Torque

From the study of mechanics, it is known that the following equations apply for a rigid body in plane motion:

$$\Sigma F = Ma$$

$$\Sigma T = I\alpha$$

where:

ΣF is the vector sum, of a system of forces acting on body in the plane of motion.

M is the mass of the body.

a is the acceleration vector of the mass center (center of gravity) of the body.

ΣT is the sum of the moments of the forces and torques about an axis through the mass center normal to the plane of motion.

I is the moment of inertia of the body through the mass center.

α is the angular acceleration of the body in the plane motion.

1. Finding the acceleration of center of mass of links r_3 and r_4 ; (Figure A.2):

$$d/dt\{r_2(\dot{\theta}_2) + r_3(\dot{\theta}_3)\} = d/dt\{r_4(\dot{\theta}_4)\}$$

$$r_2 e^{i\theta_2} (\ddot{\theta}_2) + r_2 (\dot{\theta}_2)^2 e^{i(\theta_2 + \pi/2)} + r_3 e^{i\theta_3} (\ddot{\theta}_3) + r_3 (\dot{\theta}_3)^2 e^{i(\theta_3 + \pi/2)} =$$

$$= r_4 e^{i\theta_4} (\ddot{\theta}_4) + r_4 (\dot{\theta}_4)^2 e^{i(\theta_4 + \pi/2)}$$

$$r_2 (\ddot{\theta}_2) + r_2 (\dot{\theta}_2)^2 e^{i\pi/2} + r_3 (\ddot{\theta}_3) + r_3 (\dot{\theta}_3)^2 e^{i\pi/2} = r_4 (\ddot{\theta}_4) + r_4 (\dot{\theta}_4)^2 e^{i\pi/2}$$

$$r_2 [(\ddot{\theta}_2) + (\dot{\theta}_2)^2 e^{i\pi/2}] + r_3 [(\ddot{\theta}_3) + (\dot{\theta}_3)^2 e^{i\pi/2}] = r_4 [(\ddot{\theta}_4) + (\dot{\theta}_4)^2 e^{i\pi/2}]$$

2. Finding acceleration of g2 and g3:

Acceleration of mass g2 (Figure A.2):

$$\begin{aligned} a_{g2} &= d/dt(\mathbf{v}_{g2}) = d/dt[r_{g2}e^{i(\theta_2+\gamma_2)}(\dot{\theta}_2)e^{i\pi/2}] \\ &= [r_{g2}(\dot{\theta}_2)^2e^{i(\theta_2+\gamma_2+\pi/2)} + r_{g2}e^{i(\theta_2+\gamma_2)}(\ddot{\theta}_2)]e^{i\pi/2} \\ &= [r_{g2}(\dot{\theta}_2)^2e^{i\pi/2} + r_{g2}(\ddot{\theta}_2)]e^{i\pi/2} \\ &= r_{g2}[(\dot{\theta}_2)^2e^{i\pi/2} + (\ddot{\theta}_2)]e^{i\pi/2} \end{aligned}$$

Acceleration of mass g3:

$$\begin{aligned} a_{g3} &= d/dt(\mathbf{v}_{g3}) = d/dt\{[r_2e^{i\theta_2}(\dot{\theta}_2) + r_3e^{i(\theta_3+\gamma_3)}(\dot{\theta}_3)]e^{i\pi/2}\} \\ &= (r_2(\dot{\theta}_2)^2e^{i(\theta_2+\pi/2)} + r_2e^{i\theta_2}(\ddot{\theta}_2) + r_3(\dot{\theta}_3)^2e^{i(\theta_3+\gamma_3+\pi/2)} + \\ &\quad + r_3e^{i(\theta_3+\gamma_3)}(\ddot{\theta}_3))e^{i\pi/2} \end{aligned}$$

$$a_{g3} = (r_2[(\dot{\theta}_2)^2e^{i\pi/2} + (\ddot{\theta}_2)] + r_3[(\dot{\theta}_3)^2e^{i\pi/2} + (\ddot{\theta}_3)])e^{i\pi/2}$$

3. Finding acceleration of g2, g3, g4, and p4 with respect to the link frames (Figure A.2):

(a): Respect to frame of link 2:

$$\begin{aligned} g2ddx2 &= rg2dd * \cosd(t2) + ig2dd * \sind(t2) \\ g2ddy2 &= -rg2dd * \sind(t2) + ig2dd * \cosd(t2) \end{aligned}$$

(b): Respect to frame of link 3:

$$\begin{aligned} g3ddx3 &= rg3dd * \cosd(t3) + ig3dd * \sind(t3) \\ g3ddy3 &= -rg3dd * \sind(t3) + ig3dd * \cosd(t3) \end{aligned}$$

(c): Respect to frame of link 4:

$$\begin{aligned} g4ddx4 &= rg4dd * \cosd(t4) + ig4dd * \sind(t4) \\ g4ddy4 &= -rg4dd * \sind(t4) + ig4dd * \cosd(t4) \end{aligned}$$

$$p4ddx4=rp4dd*\cosd(t4)+ip4dd*\sind(t4)$$

$$p4ddy4=-rp4dd*\sind(t4)+ip4dd*\cosd(t4)$$

4. The external force that acted on the links are described in fixed coordinated frame shown in Figure A.10, and each force has a real and imaginary part. Those parts transfer to frame {4}.

Finding forces with respect to the link frame {4}:

$$fp4x4=rfp4*\cosd(t4)+ifp4*\sind(t4)$$

$$fp4y4=-rfp4*\sind(t4)+ifp4*\cosd(t4)$$

5. Finding moment of inertia of the links 2 and 3:

$$ine2=w2*r2^2/(12*g)$$

$$ine3=w3*r2^2/(12*g)$$

6. Computing reaction forces on link 2 (Figure A.11):

$$\Sigma Fx2=0$$

$$f32x2+f12x2+(w2/g)*(-g2ddx2)=0$$

$$\Sigma Fy2=0$$

$$f32y2+f12y2+(w2/g)*(-g2ddy2)=0$$

$$\Sigma Mcg2=0$$

$$(f32y2)*(r2-g2)-f12y2*g2+t0+ine2*(-t2dd)=0$$

7. Computing reaction forces on link 4 (Figure A.10):

$$\Sigma Fx4=0$$

$$f34x4+f14x4+(w4/g)*(-g4ddx4)=0$$

$$\Sigma Fy4=0$$

$$f34y4+f14y4+(w4/g)*(-g4ddy4)=0$$

$$\Sigma Mcg4=0$$

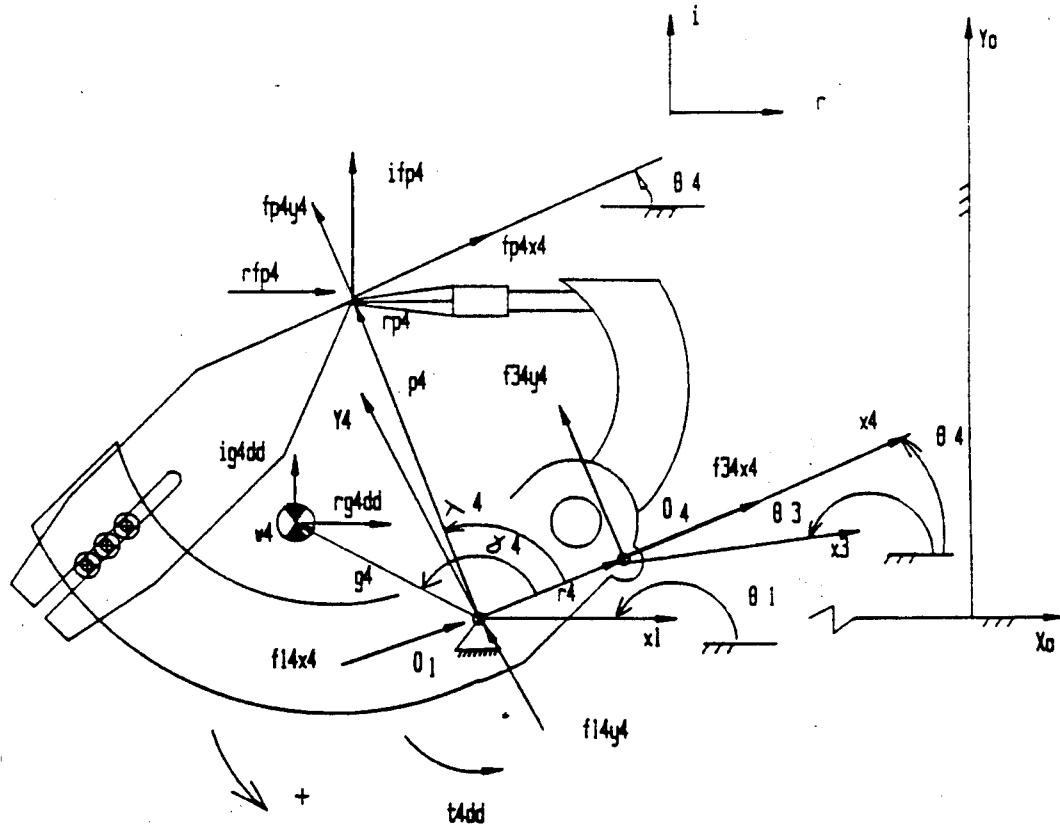

Figure A.10: Reaction Forces on Link 4

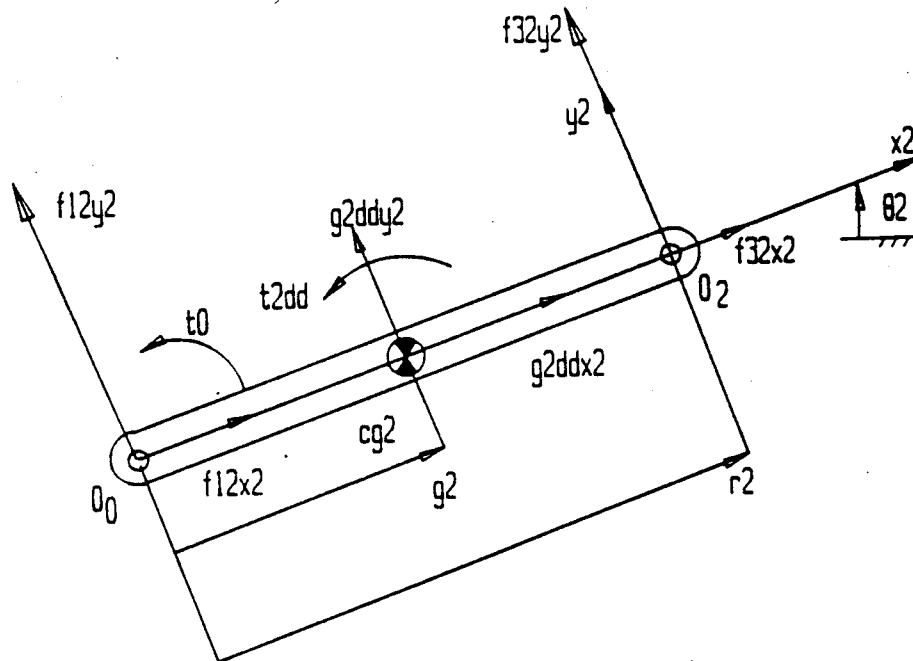

Figure A.11: Reaction Forces on Link 2

$$\begin{aligned}
 & (f_{14x4} + f_{34x4}) * g_4 * \text{sind}(\text{gam}_4) - (f_{14x4}) * g_4 * \text{cosd}(\text{gam}_4) + (f_{34y4}) * \\
 & (r_4 - g_4 * \text{cosd}(\text{gam}_4)) + \text{ine}_4 * (-t_4 \text{dd}) + f_{p4y4} * (p_4 - g_4 * \text{cosd}(\text{gam}_4)) \\
 & - f_{p4x4} * g_4 * \text{sind}(\text{gam}_4 - \text{lam}_4) = 0
 \end{aligned}$$

8. Transformation of the reaction forces to link 3

(Figure A.12):

$$f_{34x3} = -f_{34x4} * \text{cosd}(t_4 - (t_3 - 180)) - (-f_{34y4}) * \text{sind}(t_4 - (t_3 - 180))$$

$$f_{32x3} = -f_{32x2} * \text{cosd}(t_2 - (t_3 - 180)) - (-f_{32y2}) * \text{sind}(t_2 - (t_3 - 180))$$

$$f_{34y3} = -f_{34x4} * \text{sind}(t_4 - (t_3 - 180)) + (-f_{34y4}) * \text{cosd}(t_4 - (t_3 - 180))$$

$$f_{32y3} = -f_{32x2} * \text{sind}(t_2 - (t_3 - 180)) + (-f_{32y2}) * \text{cosd}(t_2 - (t_3 - 180))$$

9. Computing reaction forces of link 3 (Figure A.13):

$$\Sigma F_{x3} = 0$$

$$f_{34x3} + f_{32x3} + (w_4/g) * (-g_3 \text{dd}x_3) = 0$$

$$\Sigma F_{y3} = 0$$

$$f_{34y3} + f_{32y3} + (w_4/g) * (-g_3 \text{dd}y_3) = 0$$

$$\Sigma M_{cg3} = 0$$

$$f_{32y3} * g_3 - f_{34y3} * (r_3 - g_3) + \text{ine}_3 * (-t_3 \text{dd}) = 0$$

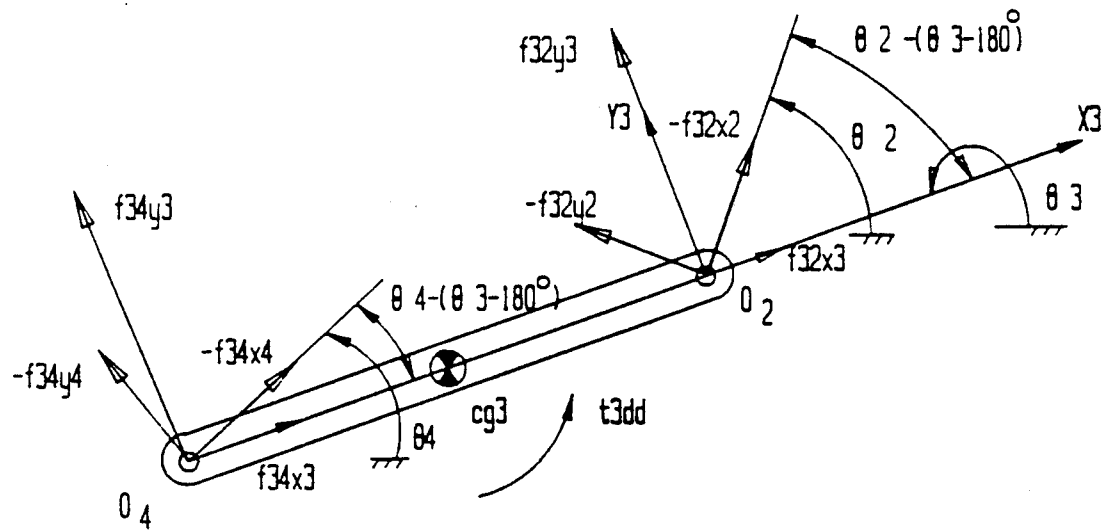

Figure A.12: Transformation of the Reaction Forces to Link 3

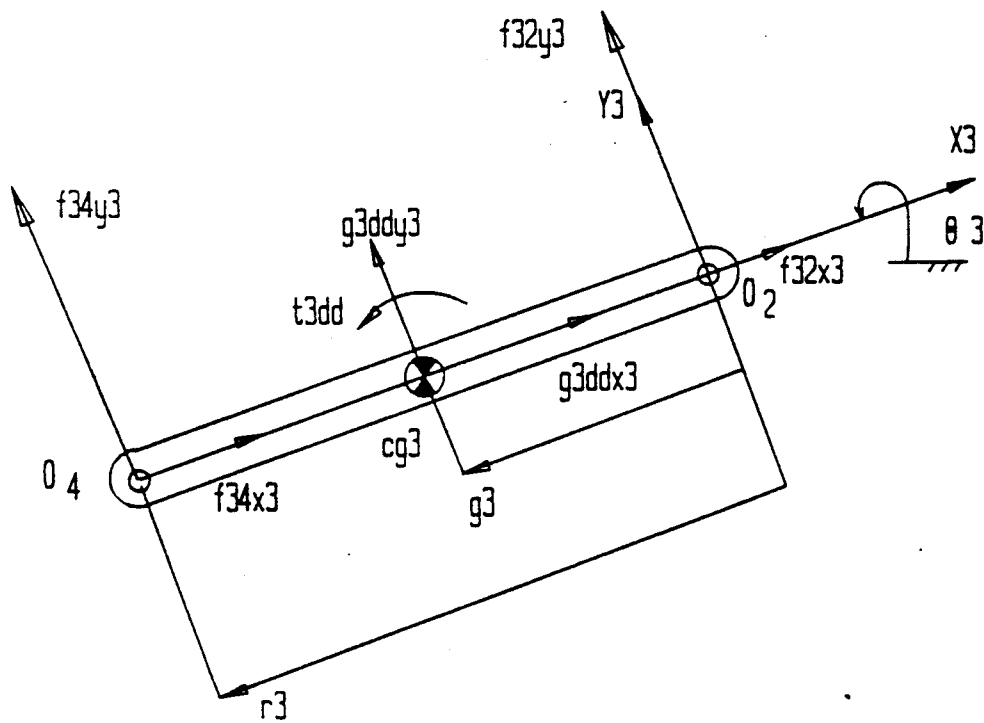

Figure A.13: Reaction Forces on Link 3

Solution of the Dynamic Equations

The series of equations developed and shown above was used to analyze the dynamic turning process by using a sequential solution procedure using TK Solver.

Program Input

During the turning operation the collar applies force on the clipper tips. This force must be determined to be input to the dynamic modeling program. Figure A.14 describes the force measured on the bench machine. This force varies for different collar size or style. The measurement was done on 15.5 collar size.

Appendix C presents the variable data sheet used for program input. In this sheet each parameter used for program calculation is defined.

Dynamics Modeling Results

1. Link Acceleration:

Figure A.15 describes the output angular acceleration of links 3 and 4 during one cycle of the turner. Link 2 is the input link acceleration for the system.

2. Acceleration of the Clipper Tips:

The acceleration of the clipper tips is important since the collar points are held by the two clipper tips

during the turning process. Figure A.16 shows the acceleration profile for the clipper tips.

3. Driving Torque:

To impose the position velocity and acceleration on the system by driving link 2 it is required to supply the torque from the driving actuator. Figure A.17 presents the torque that is required to drive the system in 2 second time cycle.

4. These results show Forces Acting on the Joints:

Summation of the forces acting on each link permits the joint forces to be found. Figure A.18 through A.23 represents the joint force during the turning process.

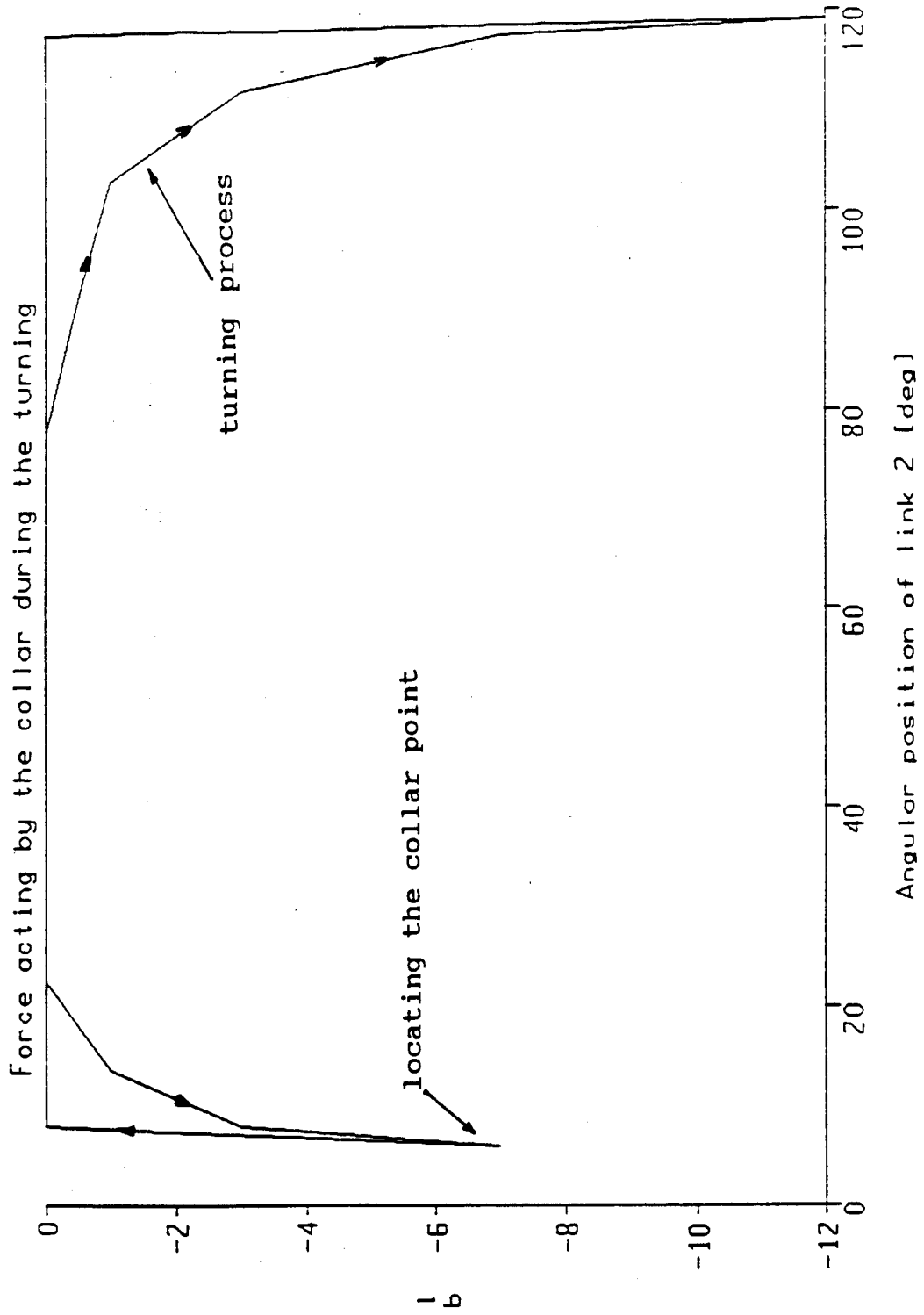

Figure A.14: Force Acting by the Collar During the Turning

Angular Acceleration of Links 2,3 and 4.

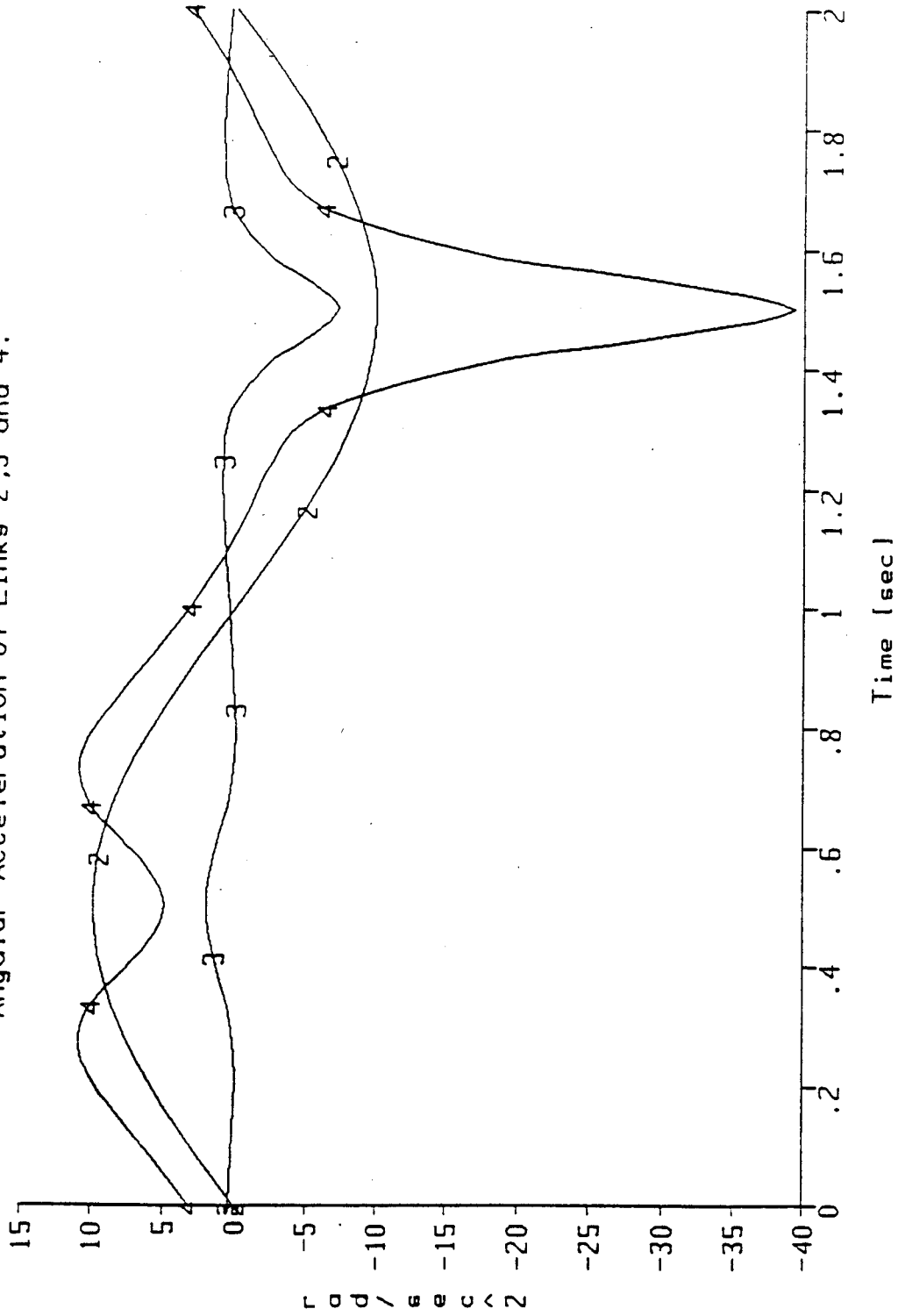

Figure A.15: Angular Acceleration of Links 2, 3, and 4

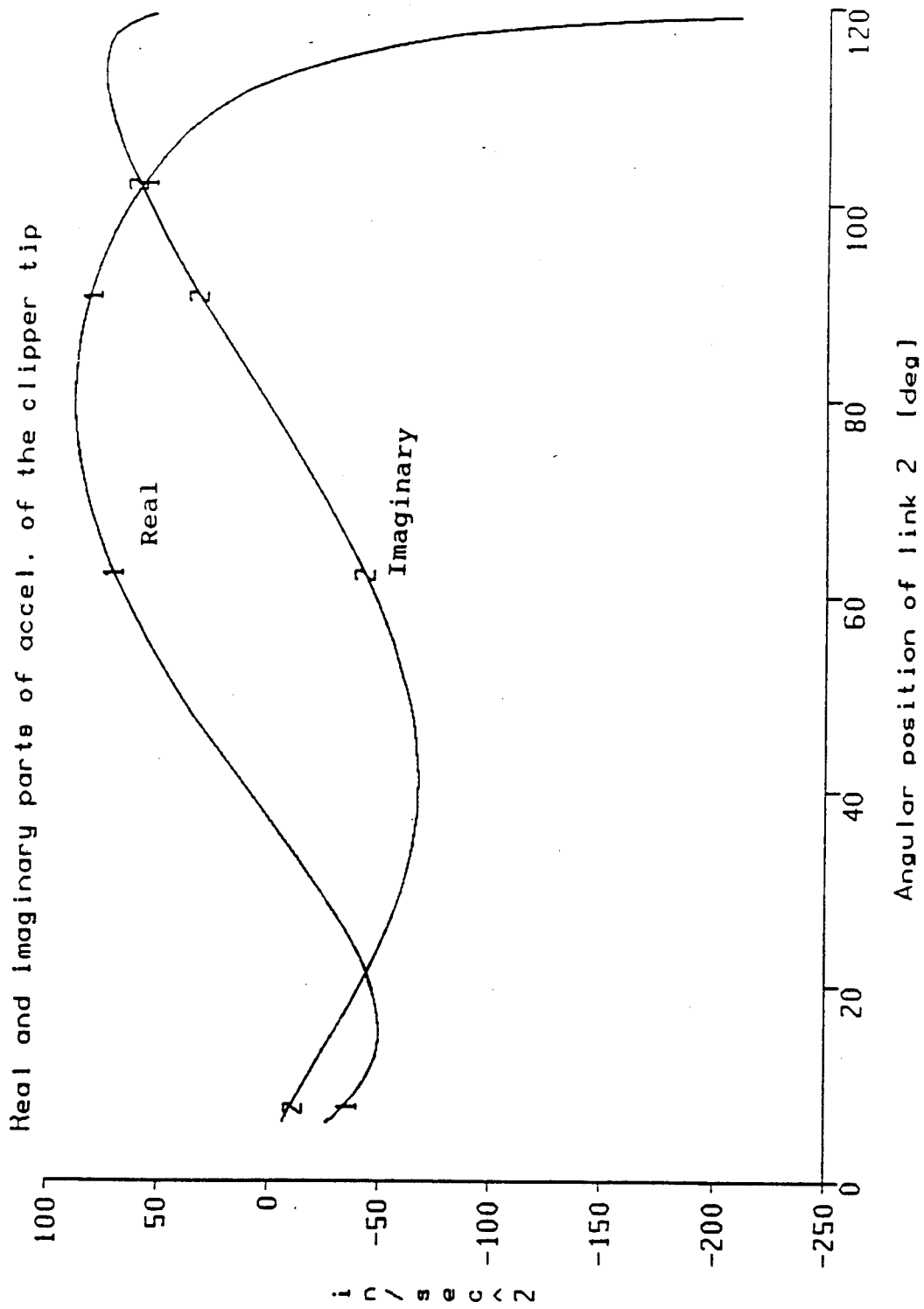

Figure A.16: Real and Imaginary Parts of Acceleration of the Clipper Tip

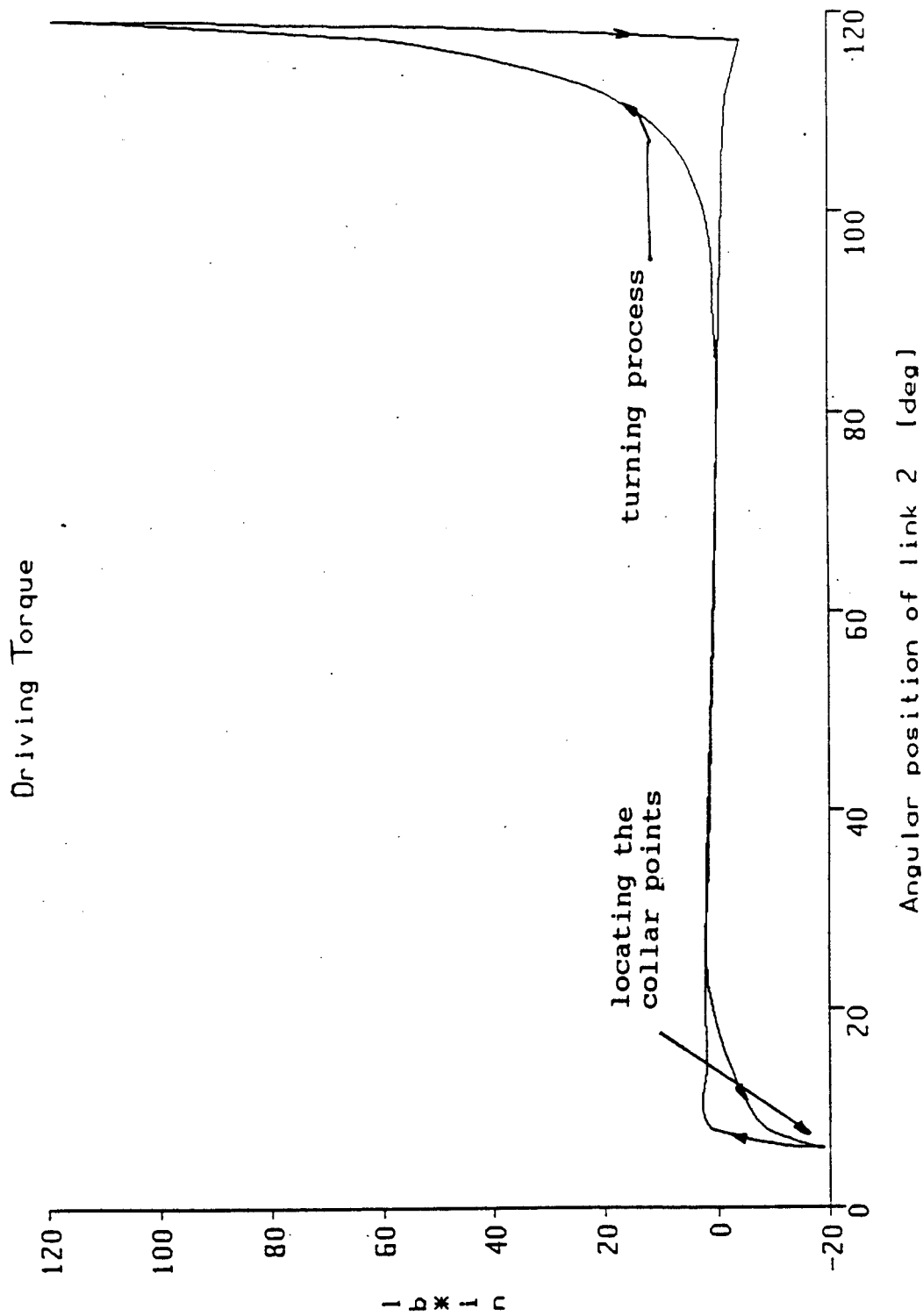

Figure A.17: Driving Torque

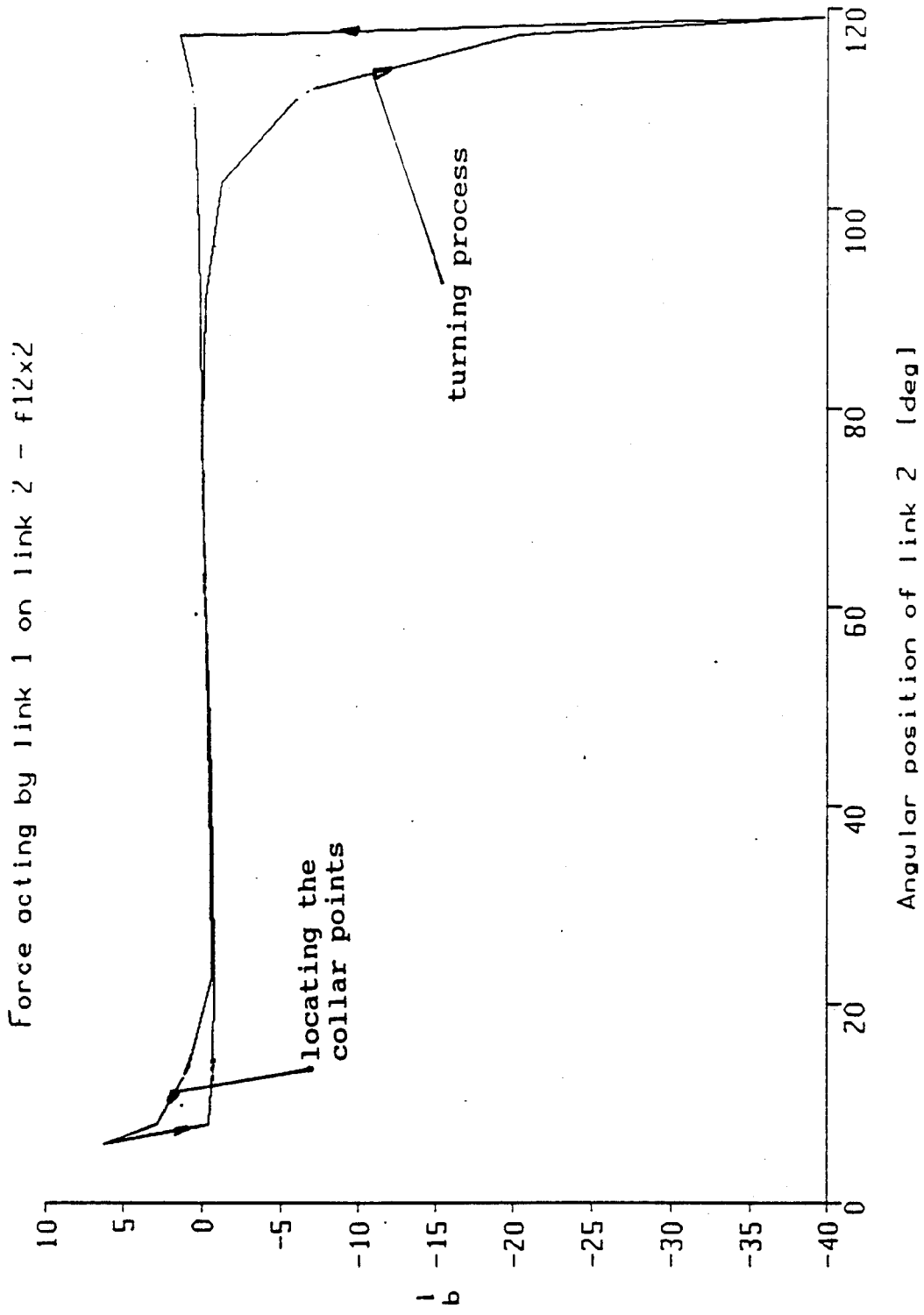

Figure A.18: Force Acting by Link 1 on Link 2 - f12x2

Force acting by link 1 on link 2 - f_{12y2}

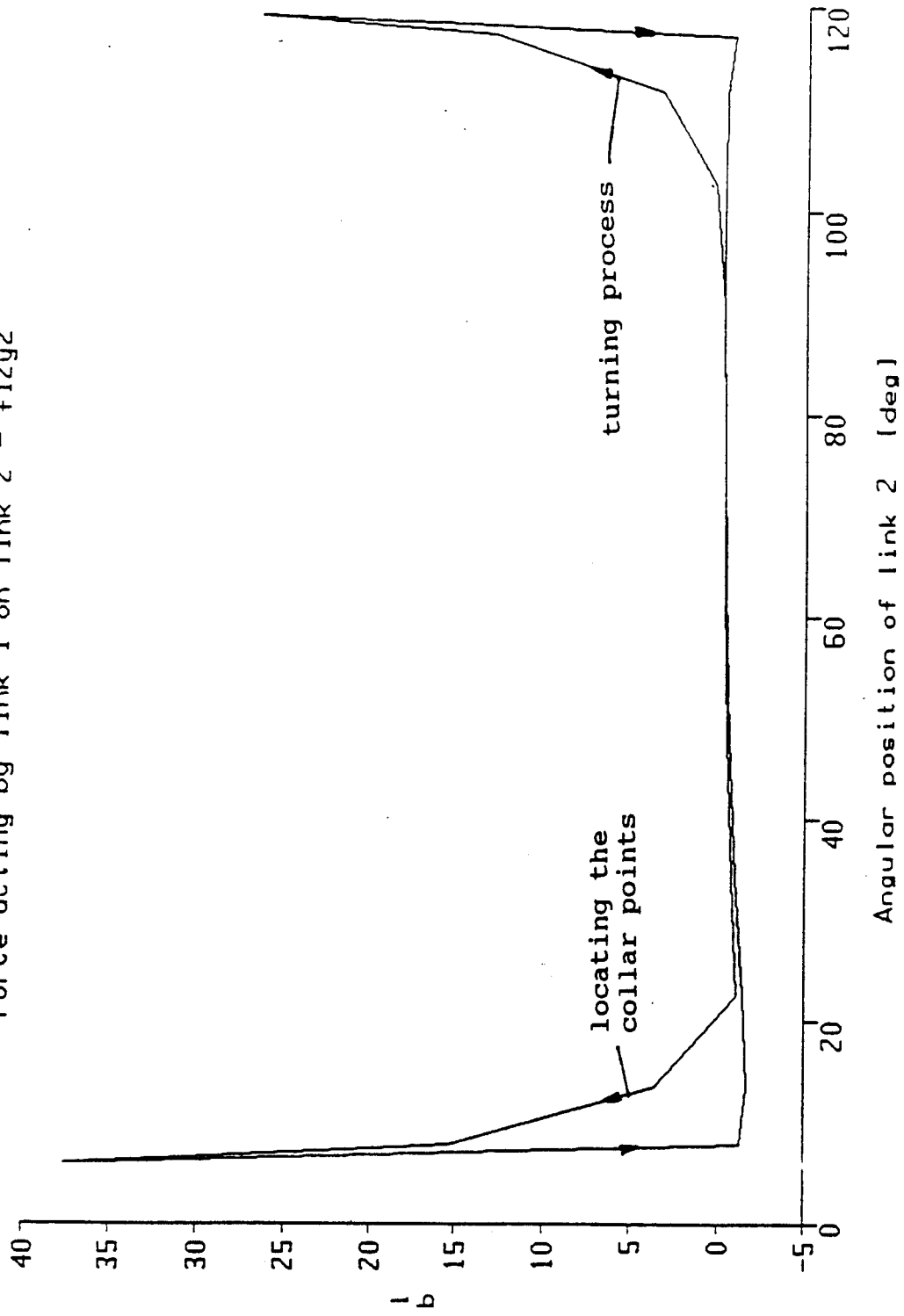

Figure A.19: Force Acting by Link 1 on Link 2 - f_{12y2}

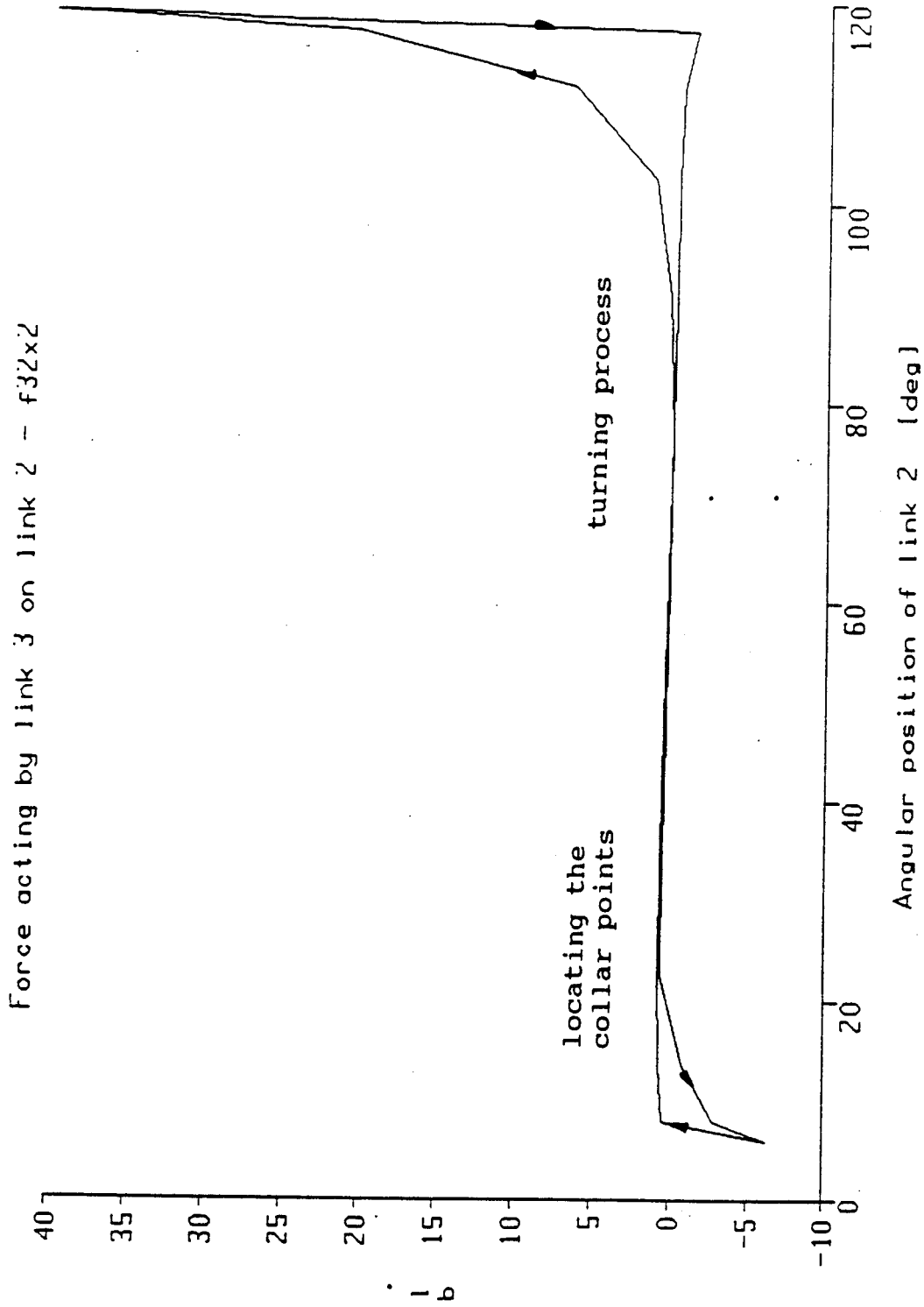

Figure A.20: Force Acting by Link 3 on Link 2 - f32x2

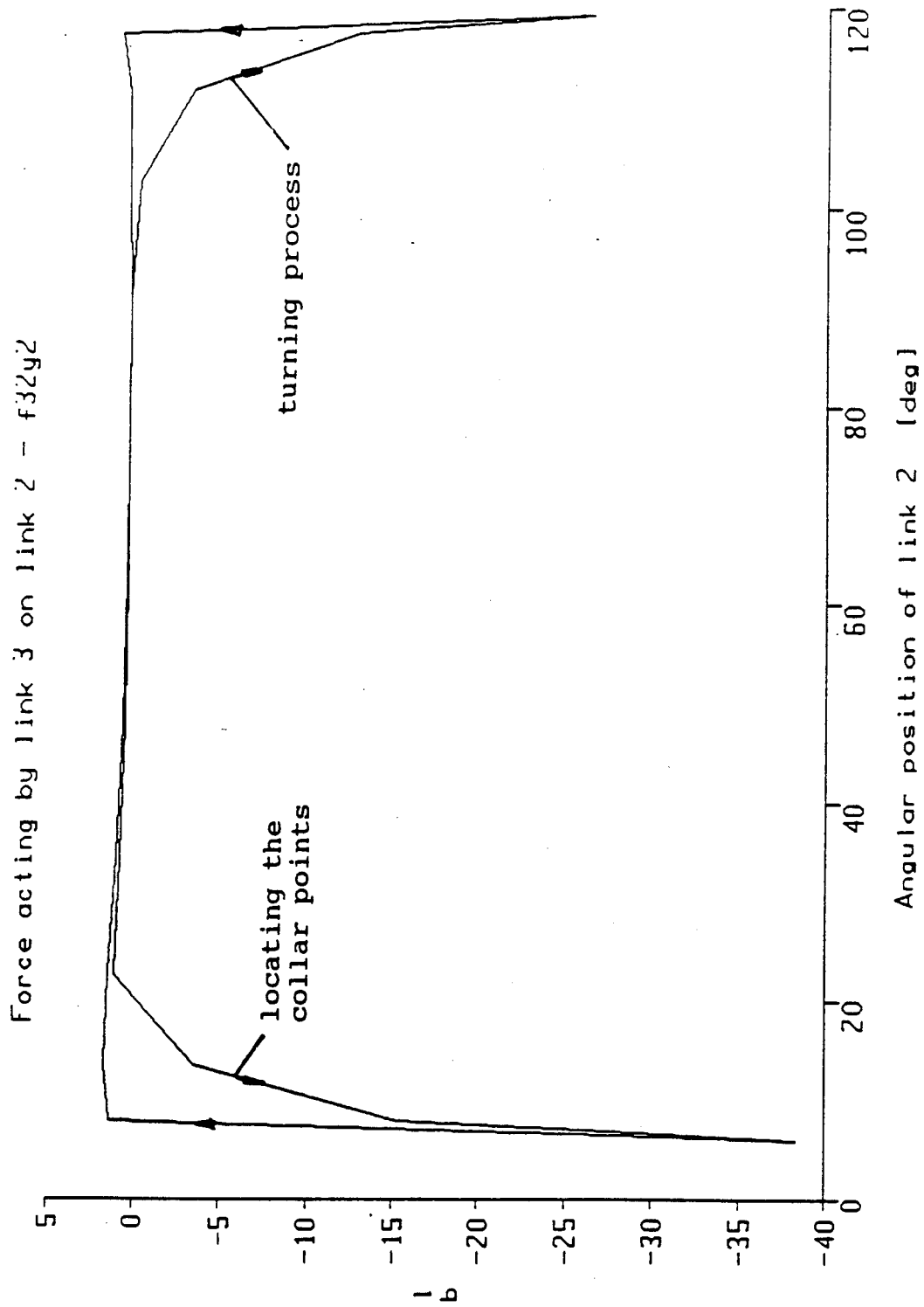

Figure A.21: Force Acting by Link 3 on Link 2 - f_{32y2}

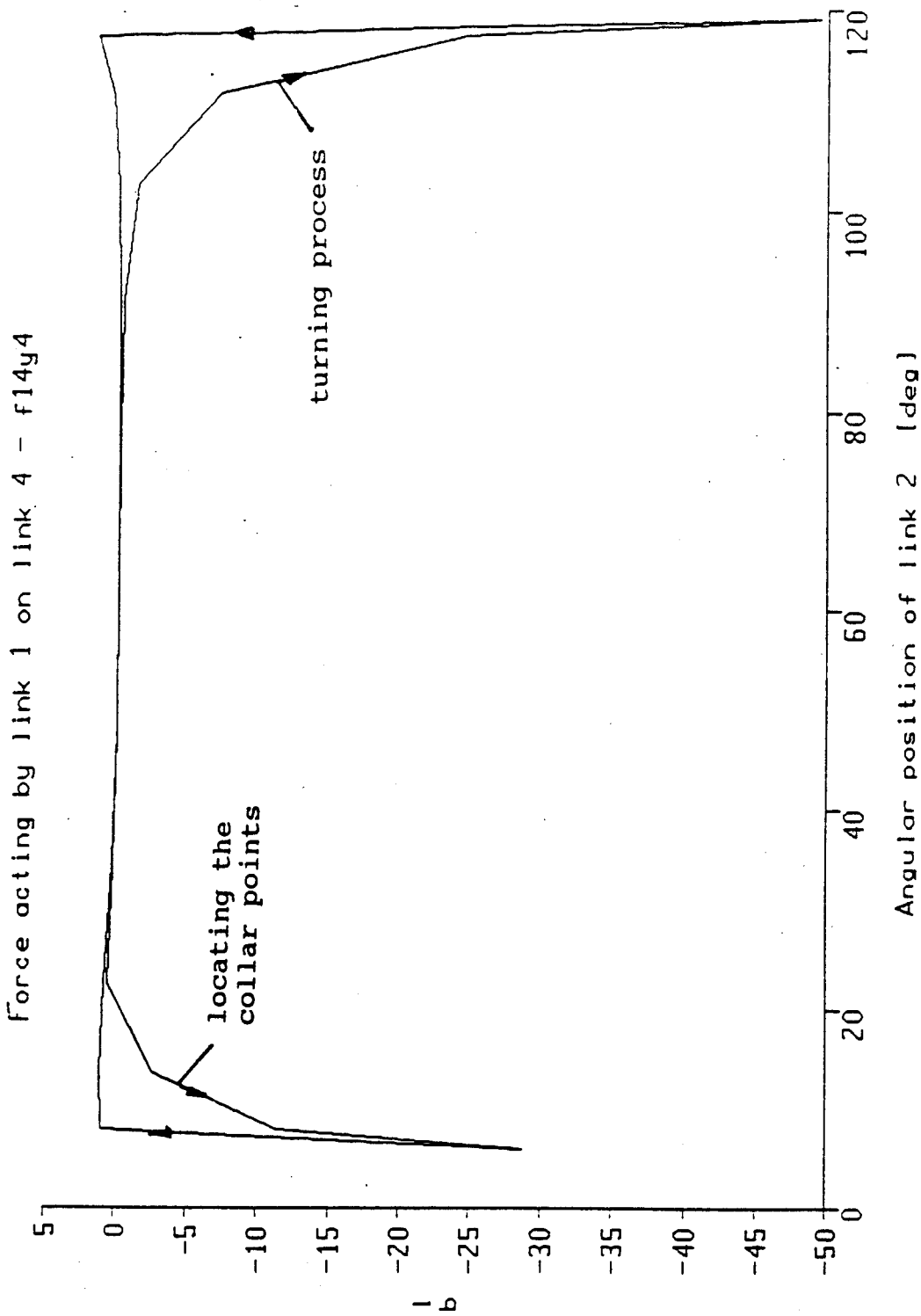

Figure A.22: Force Acting by Link 1 on Link 4 - f14y4

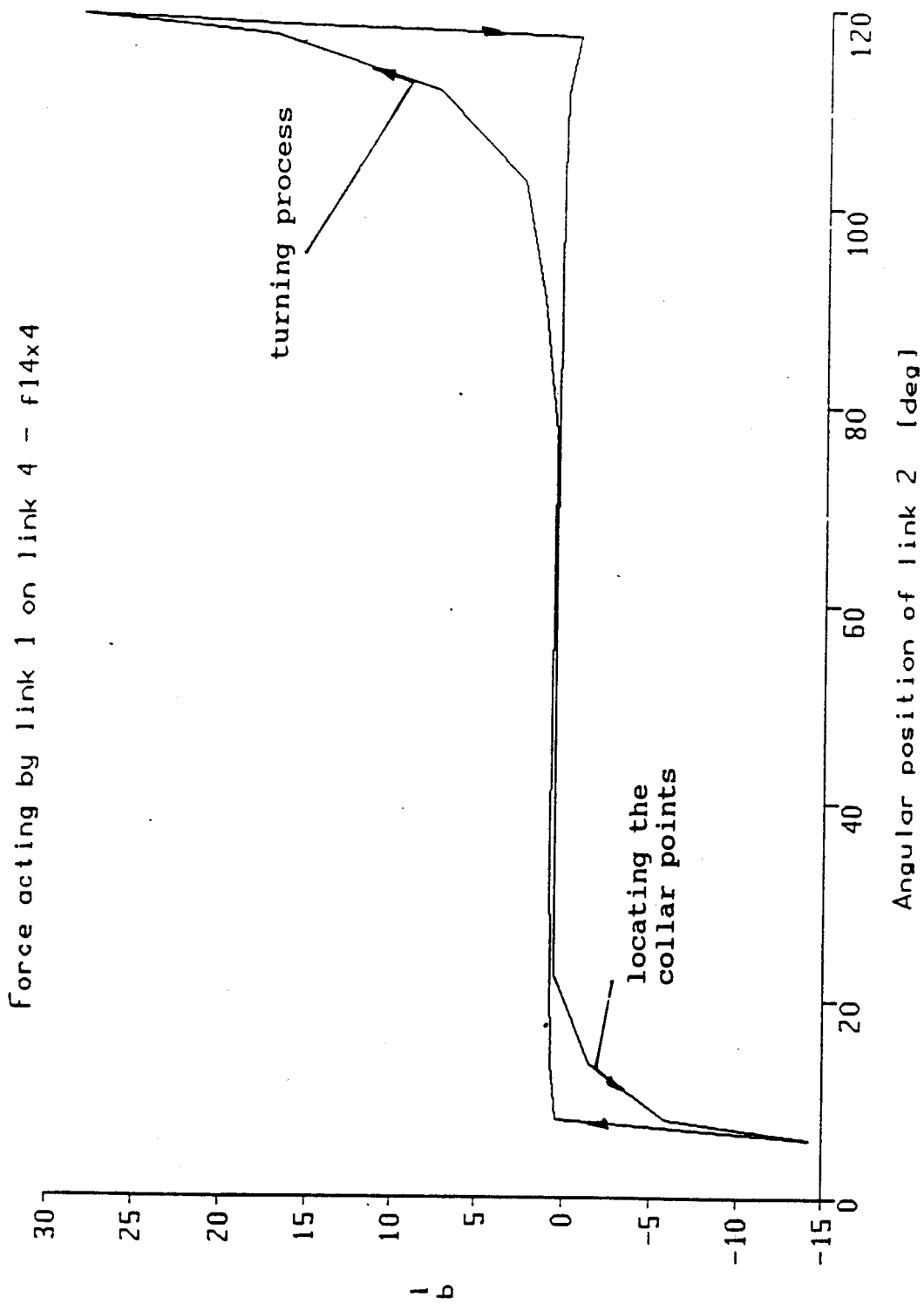

Figure A.23: Force Acting by Link 1 on Link 4 - f14x4

Appendix B

Links Parameters and Mass Centers

Parameters of Link 5

There are three parts in link 5 as is shown in Figure B.1. Each part has a center of mass and vector location from joint 1 to the center of mass.

Table B.1: Parameters of Link 5.

part	m[gr]	θ [degree]	r[in]	r[mm]
a	250	185.93	3.75	95.25
b	1250	150.01	5.17	131.32
c	400	45	1.08	27.18

Center of Mass for Link 5:

To calculate the center of mass the notation $c\theta$ represents $\cos\theta$ and $s\theta$ represents $\sin\theta$. We also denote $(\theta_1+\theta_2)$ by θ_{12} , and $\cos(\theta_1+\theta_2)$ as c_{12} . The center of mass is described by the radius r and the angle θ .

The sum of the moments of the gravitational forces in the X and Y directions equal to equivalent mass terms.

X direction:

$$m_a r_a c\theta_a + m_b r_b c\theta_b + m_c r_c c\theta_c = (m_a + m_b + m_c) r c\theta$$

Y direction:

$$m_a r_a s\theta_a + m_b r_b s\theta_b + m_c r_c s\theta_c = (m_a + m_b + m_c) r s\theta$$

The angle of the center of mass:

$$\tan\theta = (m_a r_a s\theta_a + m_b r_b s\theta_b + m_c r_c s\theta_c) /$$

$$(m_a r_a c\theta_a + m_b r_b c\theta_b + m_c r_c c\theta_c)$$

$$\tan\theta = -.55$$

$$\theta = -28.8^\circ$$

The radius of the center of mass:

$$r = (m_a r_a c\theta_a + m_b r_b c\theta_b + m_c r_c c\theta_c) / (m_a + m_b + m_c) c\theta$$

$$r = 95 \text{ mm}$$

Link 5 can be described as an arm with a center of mass, which is not collinear, is shown in Figure B.1 (b).

Parameters of Link 6:

There are two parts in link 6, as shown in Figure B.2. Each of the parts has a mass and vector location from joint 5 to the center of mass, as described in Table B.2.

Table B.2: Parameter of link 6.

part	m[gr]	θ [degree]	r[in]	r[mm]
d	250	0	2.26	57.4
e	200	62.5	4.05	102.87

Center of Mass for Link 6:

The procedure used for link 5 is similarly used for link 6. The center of mass is described with the radius vector r and the θ angle.

The angle of the center of mass:

$$\tan(\theta) = (m_d r_d s\theta_d + m_e r_e s\theta_e) / (m_d r_d c\theta_d + m_e r_e c\theta_e)$$

$$\tan(\theta) = 0.753$$

$$\theta = 37^\circ$$

The radius of the center of mass:

$$r = (m_d r_d c\theta_d + m_e r_e c\theta_e) / (m_d + m_e) c\theta$$

$$r = 50.6 \text{ mm}$$

Link 6 can now be described as an arm with a center of mass which is not collinear as shown in Figure B.2 (b).

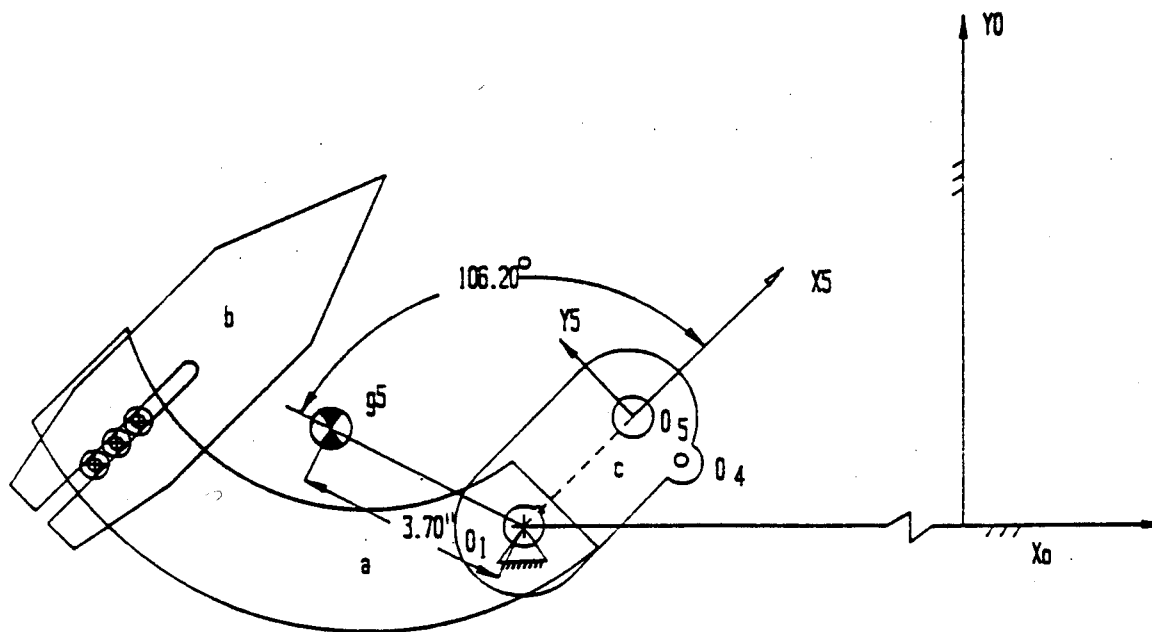
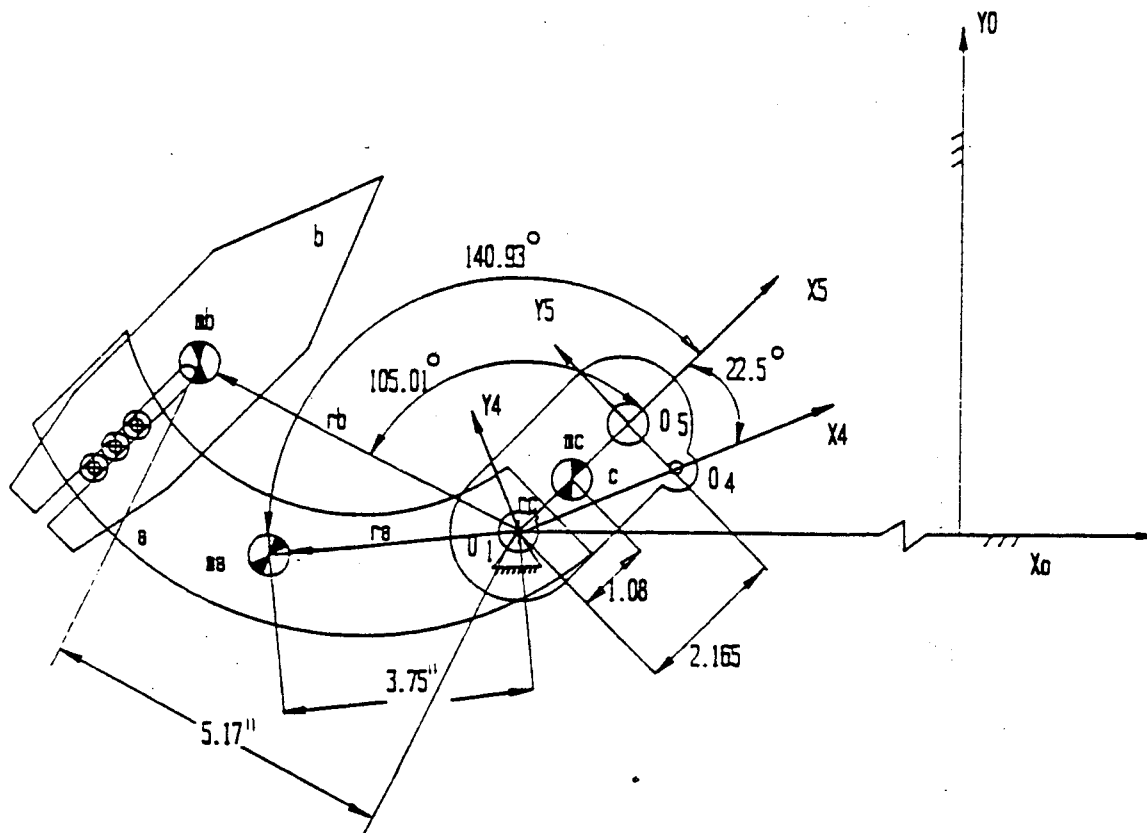

Figure B.1: Link 5 - Consists of Three Parts

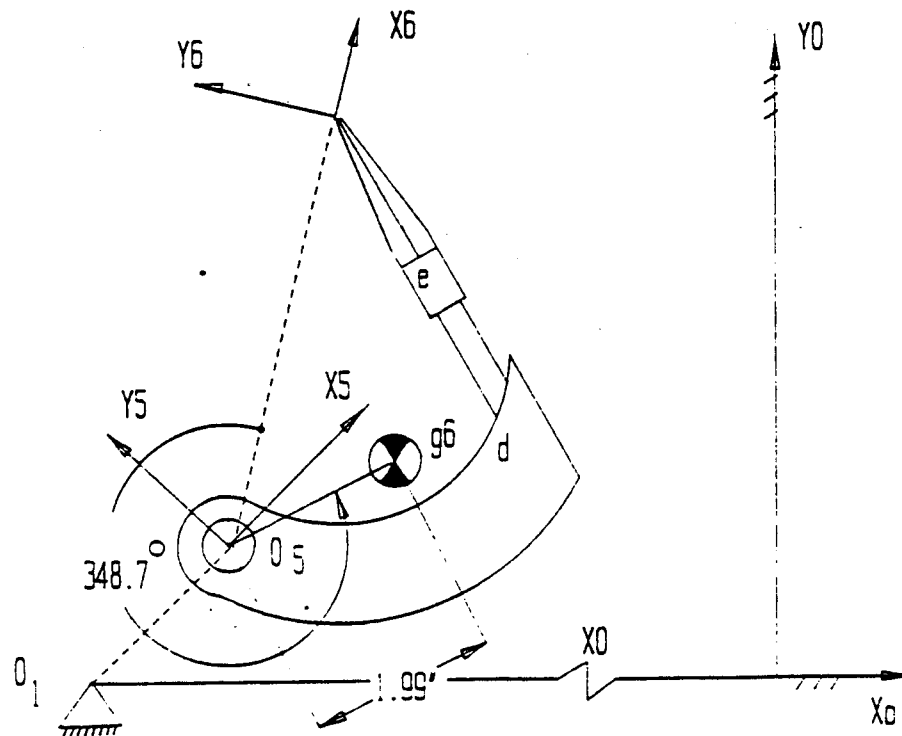
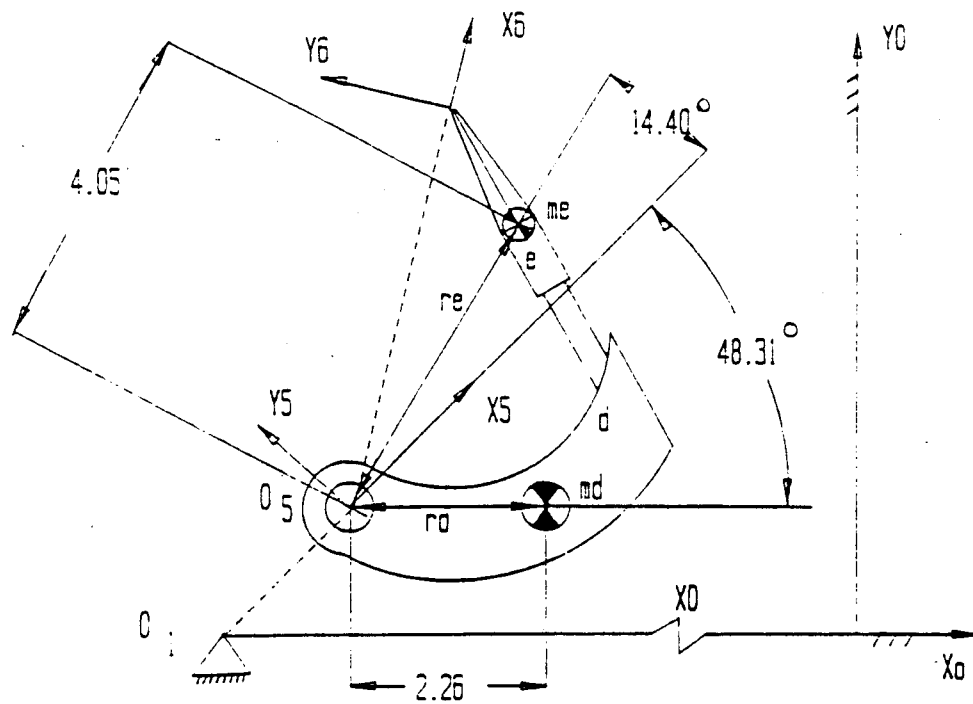

Figure B.2: Link 6 - Consists of Two Parts

Appendix C

Analysis Including Definition

Table 1: Variable sheet: displays variable, values and units.

Table 2: Rule sheet: displays the equations that were utilized to solve the model.

St	Input	Name	VARIABLE	SHEET	
L	1	t	Output	Unit	Cycle time
				sec	
	9	r1		in	Length of link 1
	3	r2		in	Length of link 2
	10	r3		in	Length of link 3
	2.17	r4		in	Length of link 4
	5	r5			
L	180	t1		deg	Angular Position of link 1
		t2	62.5	deg	Angular Position of link 2
	0	p2		in	Radial distance to force pt on link 2
	0	p3		in	Radial distance to force pt on link 3
	5.5	p4		in	Radial distance to force pt on link 4
	2.5	g2		in	Radial distance to cg2 on link 2
	4.5	g3		in	Radial distance to cg3 on link 3
L		g4	2.0790788	in	Radial distance to cg4 on link 4
	3.74	g5		in	Radial distance to cg5 on link 5
	1.99	g6		in	Radial distance to cg6 on link 6
	0	gam2		deg	Angular position of cg2 on link 2
	0	gam3		deg	Angular position of cg3 on link 3
L		gam4	83.08532	deg	Angular position of cg4 on link 4
	140.93	gam5		deg	Angular position of cg5 on link 5
	-14.4	gam6		deg	Angular position of cg6 on link 6
	0	lam2		deg	Angular position of force pt on link 2
	0	lam3		deg	Angular position of force pt on link 3
	81.69	lam4		deg	Angular position of force pt on link 4
L		t2d	3.1301939	rad/sec	Angular velocity of link 2
L		t2dd	9.012E-13	rad/sec	Angular acceleration of link 2
L		t3	183.02701	deg	(GUESS) Angular position of link 3
L		t3d	.28088381	rad/sec	(GUESS) Angular velocity of link 3
L		t3dd	.41011716	rad/sec ²	(GUESS) Angular acceleration of link 3
L		t4	79.399358	deg	(GUESS) Angular position of link 4
L		t4d	3.8356097	rad/sec	(GUESS) Angular velocity of link 4
L		t4dd	3.1390123	rad/sec	(GUESS) Angular acceleration of link 4
L		t5	101.89936	deg	Angular position of link 5
L	0	t6		deg	Angular position of link 6 (on -off)
L		t6base	101.89936	deg	Angular position of link 6 relativ to t
L		oup4		deg	Output angle relative to the basis
		rr1	-9	in	Real part of vector r1 (link 1)
		ir1	0	in	Imaginary part of vector r1 (link 1)
		rr2	1.3852458	in	Real part of vector r2 (link 2)
		ir2	2.6610325	in	Imaginary part of vector r2 (link 2)
		rr3	-9.986048	in	Real part of vector r3 (link 3)
		ir3	-.5280673	in	Imaginary part of vector r3 (link 3)
		rr4	.39919833	in	Real part of vector r4 (link 4)
		ir4	2.1329652	in	Imaginary part of vector r4 (link 4)
		rg2	1.1543715	in	Real part of vector cg2
		ig2	2.2175271	in	Imaginary part of vector position, cg2
		rg3	-4.493721	in	Real part of vector position, cg2 on li
		ig3	-.2376303	in	Imaginary part of vector position, cg3
		rg4	-1.982685	in	Real part of vector g4
		ig4	.62572127	in	Imaginary part of vector position, cg4

Table C.1: Variable Sheet

	rg2d	-6.94129	in/sec	Real part of vel. of cg2
	ig2d	3.6134067	in/sec	Imaginary part of vel. of cg2
	rg3d	-8.262801	in/sec	Real part of vel of cg3
	ig3d	3.0738745	in/sec	Imaginary part of vel. of cg3
	rg4d	-2.400023	in/sec	Real part of vel of cg4
	ig4d	-7.604808	in/sec	Imaginary part of vel. of cg4
	rg2dd	-11.31066	in/sec^2	Real part of accel of cg2
	ig2dd	-21.72758	in/sec^2	Imaginary part of accel of cg2
	rg3dd	-13.1208	in/sec^2	Real part of accel of cg3
	ig3dd	-27.8973	in/sec^2	Imaginary part of accel of cg3
	rg4dd	27.204927	in/sec^2	Real part of accel of cg4
	ig4dd	-15.42922	in/sec^2	Imaginary part of accel of cg4
	rp2	0	in	Real part of the location of force pt o
	ip2	0	in	Imaginary part of vector position, forc
	rp3	0	in	Real part of vector position, force pt
	ip3	0	in	Imaginary part of vector position, forc
L	rp4	-5.203138	in	Real part of vector position, force pt
L	ip4	1.7825122	in	Imaginary part of vector position, forc
	rp2d	0	in/sec	Real part of vel of force pt on link 2
	ip2d	0	in/sec	Imaginary part of vel of force pt on li
	rp3d	-8.329548	in/sec	Real part of vel of force pt on link 3
	ip3d	4.3360881	in/sec	Imaginary part of vel of forcrc pt on li
L	rp4d	-6.837021	in/sec	Real part of vel of force pt on link 4
L	ip4d	-19.95721	in/sec	Imaginary part of vel of forcrc pt on li
	rp2dd	0	in/sec^2	Real part of accel of force pt 2
	ip2dd	0	in/sec^2	Imaginary part of accel of force pt 2
	rp3dd	-13.5728	in/sec^2	Real part of accel of force pt 3
	ip3dd	-26.0731	in/sec^2	Imaginary part of accel of force pt 3
L	rp4dd	70.952735	in/sec^2	Real part of accel of force pt 4
L	ip4dd	-42.55686	in/sec^2	Imaginary part of accel of force pt 4
90	pi2			PI/2 (degrees)
.2	row2		lb/in	material density of link 2
.2	row3		lb/in	material density of link 3
.2	row4		lb/in	material density of link 4
	w2	.6	lb	weight of link 2
	w3	2	lb	weight of link 3
	w4	5.17	lb	weight of link 4
	w5	4.18	lb	weight of link 5
	w6	.99	lb	weight of link 6
.55	ma		lb	weight of the clipper's arm
2.75	mb		lb	weight of cliper
.88	mc		lb	weight of part on the C-Shape Bracet
.55	md		lb	weight of the turner's arm
.44	me		lb	weight of the turner
385.8	g		in/sec^2	gravity acceleration
	g2ddx2	-2.25E-12	in/sec^2	Acceleration with respect to link frame
	g2ddy2	-24.49528	in/sec^2	Acceleration with respect to link fram
	fp2x2	0	lb	Forces acting on link 2 with respect to
	fp2y2	0	lb	Forces acting on link 2 with respect to
L	f12x2	-.1600642	lb	(G) Forces(Output1) acting by link1 on

Table C.1: Variable Sheet (Continued)

L	f32y2	.29880782	lb	(G) Forces(Output2) acting by link3 on
L	f32x2	.1600642	lb	Forces(Output3) acting by link3 on link
L	f12y2	-.3369031	lb	forces(Output4) acting by link1 on link
L	f34x4	-.1256883	lb	(G) Forces(Output5) acting by link3 on
L	f34y4	.11807095	lb	Forces(Output6) acting by link 3 on lin
L	f14x4	.52206867	lb	Forces(Output7) acting by link 1 on lin
L	f14y4	-.2542386	lb	Forces(Output8) acting by link1 on link
	g4ddy4	-10.16122	in/sec^2	Acceleration with respect to the link f
	g4ddx4	29.579025	in/sec^2	Acceleration with respect to the link f
	fp4x4	0	lb	Forces acting on link 4 with respect to
	fp4y4	0	lb	Forces acting on link 4 with respect to
	g3ddx3	-27.16551	in/sec^2	Acceleration with respect to link frame
	g3ddy3	14.575663	in/sec^2	Acceleration with respect to the link f
	fp3x3	0	lb	Forces acting on link 3 with respect to
	fp3y3	0	lb	Forces acting on link 3 with respect t
0	rfp2		lb	Real part of the force act on link 2
0	ifp2		lb	Imaginary part of the force act on link
0	rfp3		lb	Real part of the force act on link 3
0	ifp3		lb	Imaginary part of the force act on link
L 0	rfp4		lb	Real part of the force act on link 4
0	ifp4		lb	Imaginary part of the force act on link
	p2ddx2	0	in/sec^2	Acceleration with respect to the link
	p2ddy2	0	in/sec^2	Acceleration with respect to the link f
	p3ddx3	-25.31999	in/sec^2	Acceleration with respect to link frame
	p3ddy3	14.930694	in/sec^2	Acceleration with respect to the link f
	p4ddx4	77.570666	in/sec^2	Acceleration with respect to the link f
	p4ddy4	-28.77792	in/sec^2	Acceleration with respect to the link f
	ine2	.00116641	lb*sec^2*	Moment of inertia of link 2
	ine3	.00388802	lb*sec^2*	Moment of inertia of link 3
	ine4	.02896278	lb*sec^2*	Moment of inertia of link 4
L	to	.48019261	lb*in	Input T (Output 9)
	f34x3	-.1443605	lb	Transformation to link 3
	f32x3	-.1760863	lb	Transformation to link 3
	f32y3	.28965546	lb	Transformation to link 3
	f34y3	-.094331	lb	Transformation to link 3
L	pt4	161.08936		Angle relative to the base
L	cd	9.993723		Half the distance between the two clipp

Table C.1: Variable Sheet (Continued)

RULE SHEET

S Rule.

```

"Compute complex form for r2 and r1
(rr2,ir2)=(r2,0)*eit(t2)
(rr1,ir1)=(r1,0)*eit(t1)

"Find positions of r3 and r4
(rr2,ir2)+(r3,0)*eit(t3)=(rr1,ir1)+(r4,0)*eit(t4)

"Compute complex form for r3, r4, g2, g3, g4, p2, p3, p4
(rr3,ir3)=(r3,0)*eit(t3)
(rr4,ir4)=(r4,0)*eit(t4)

(rg2,ig2)=(g2,0)*eit(t2+gam2)
(rg3,ig3)=(g3,0)*eit(t3+gam3)
(rg4,ig4)=(g4,0)*eit(t4+gam4)

(rp2,ip2)=(p2,0)*eit(t2+lam2)
(rp3,ip3)=(p3,0)*eit(t3+lam3)
(rp4,ip4)=(p4,0)*eit(t4+lam4)

"Find velocity of r3 and r4
(rr2,ir2)*(t2d,0)+(rr3,ir3)*(t3d,0)=(rr4,ir4)*(t4d,0)

"Find acceleration of r3 and r4
(rr2,ir2)*((t2dd,0)+(t2d^2,0)*eit(pi2))+(rr3,ir3)*((t3dd,0)+(t3d^2,0)*eit(pi2))

"Find velocity of g2,g3,g4,p2,p3,p4
(rg2d,ig2d)=(rg2,ig2)*(t2d,0)*eit(pi2)
(rg3d,ig3d)=(rr2,ir2)*(t2d,0)*eit(pi2)+(rg3,ig3)*(t3d,0)*eit(pi2)
(rg4d,ig4d)=(rg4,ig4)*(t4d,0)*eit(pi2)

(rp2d,ip2d)=(rp2,ip2)*(t2d,0)*eit(pi2)
(rp3d,ip3d)=(rr2,ir2)*(t2d,0)*eit(pi2)+(rp3,ip3)*(t3d,0)*eit(pi2)
(rp4d,ip4d)=(rp4,ip4)*(t4d,0)*eit(pi2)

"Find acceleration of g2,g3,g4,p2,p3,p4
(rg2dd,ig2dd)=(rg2,ig2)*((t2dd,0)+(t2d^2,0)*eit(pi2))*eit(pi2)
(rg3dd,ig3dd)=(rr2,ir2)*((t2dd,0)+(t2d^2,0)*eit(pi2))+(rg3,ig3)*((t3dd,0)+(t3d^2,0)*eit(pi2))*eit(pi2)
(rg4dd,ig4dd)=(rg4,ig4)*((t4dd,0)+(t4d^2,0)*eit(pi2))*eit(pi2)

(rp2dd,ip2dd)=(rp2,ip2)*((t2dd,0)+(t2d^2,0)*eit(pi2))*eit(pi2)
(rp3dd,ip3dd)=(rr2,ir2)*((t2dd,0)+(t2d^2,0)*eit(pi2))+(rp3,ip3)*((t3dd,0)+(t3d^2,0)*eit(pi2))*eit(pi2)
(rp4dd,ip4dd)=(rp4,ip4)*((t4dd,0)+(t4d^2,0)*eit(pi2))*eit(pi2)

"Find weight of W2,W3,W4,w5,w6
w2=row2*r2
w3=row3*r3
w4=w5+w6
w5=ma+mb+mc
w6=md+me

"Find gam4 and g4 for the C-Shape Bracket
tand(gam4-22.5)=-((w5*g5*sind(gam5)+w6*g6*sind(gam6+t6))/(w5*g5*cosd(gam5)+w6*(g4-(w6*(g6*cosd(gam6+t6)+r5)+w5*g5*cosd(gam5)))/((w5+w6)*cosd(gam4-22.5))

```

Table C.2: Rule Sheet

```

"Find t5 and t6 relativ to the base
t5=t4+22.5
t6base=t5+t6

"Find acceleration of g2,g3,g4,p2,p3,p4 with resespect to the links frames
g2ddx2=rg2dd*cosd(t2)+ig2dd*sind(t2)
g2ddy2=-rg2dd*sind(t2)+ig2dd*cosd(t2)
g3ddx3=rg3dd*cosd(t3)+ig3dd*sind(t3)
g3ddy3=-rg3dd*sind(t3)+ig3dd*cosd(t3)
g4ddx4=rg4dd*cosd(t4)+ig4dd*sind(t4)
g4ddy4=-rg4dd*sind(t4)+ig4dd*cosd(t4)

p2ddx2=rp2dd*cosd(t2)+ip2dd*sind(t2)
p2ddy2=-rp2dd*sind(t2)+ip2dd*cosd(t2)
p3ddx3=rp3dd*cosd(t3)+ip3dd*sind(t3)
p3ddy3=-rp3dd*sind(t3)+ip3dd*cosd(t3)
p4ddx4=rp4dd*cosd(t4)+ip4dd*sind(t4)
p4ddy4=-rp4dd*sind(t4)+ip4dd*cosd(t4)

"Find forces with rerespect to the links frames
fp2x2=rfp2*cosd(t2)+ifp2*sind(t2)
fp2y2=-rfp2*sind(t2)+ifp2*cosd(t2)
fp3x3=rfp3*cosd(t3)+ifp3*sind(t3)
fp3y3=-rfp3*sind(t3)+ifp3*cosd(t3)
fp4x4=rfp4*cosd(t4)+ifp4*sind(t4)
fp4y4=-rfp4*sind(t4)+ifp4*cosd(t4)

Find moment of inertia of the link 2 and 3
ine2=w2*r2^2/(12*g)
ine3=w3*r2^2/(12*g)
ine4=w4*g4^2/(2*g)

"Reaction forces of link 2
f32x2+f12x2+(w2/g)*(-g2ddx2)=0
f32y2+f12y2+(w2/g)*(-g2ddy2)=0
f32y2*(r2-g2)-f12y2*g2+to+ine2*(-t2dd)=0

"Reaction forces of link 4
f34x4+f14x4+fp3x3+(w4/g)*(-g4ddx4)=0
f34y4+f14y4+fp3y3+(w4/g)*(-g4ddy4)=0
(f14y4+f34y4)*g4*sind(gam4)-(f14y4)*g4*cosd(gam4)+(f34y4)*(r4-g4*cosd(gam4))+i

"Tranformesion of the reaction forcess to link 3 direction
f34x3=(-f34x4)*cosd(t4-(t3-180))-(-f34y4)*sind(t4-(t3-180))
f32x3=(-f32x2)*cosd(t2-(t3-180))-(-f32y2)*sind(t2-(t3-180))
f34y3=(-f34x4)*sind(t4-(t3-180))+(-f34y4)*cosd(t4-(t3-180))
f32y3=(-f32x2)*sind(t2-(t3-180))+(-f32y2)*cosd(t2-(t3-180))

"Reaction forces of link 3
f34x3+f32x3+(w3/g)*(-g3ddx3)=0
f34y3+f32y3+(w3/g)*(-g3ddy3)=0
f32y3*g3-f34y3*(r3-g3)+ine3*(-t3dd)=0

"Driving Input-Sinusoidal acted
t2d=-56.5*(2*pi2)*cosd(t*2*pi2)/57^2
t2dd=56.5*(2*pi2)^2*sind(t*2*pi2)/57^3
t2=62.5-56.5*sind(t*2*pi2)

"Find Distance Between the Two Clipper Tips
pt4=t4+lam4
cd=(10.2-(-rp4))*2

```

Table C.2: Rule Sheet (Continued)

Appendix D

Hardware Specification

Motion Controller Board

Manufacturer: Precision Micro Control Corporation
3555 Aero Court
San Diego, CA 92123
(619) 565-1500

Vendor: Acquired directly from manufacturer

Part Number: DCX

Description: Eight-Axis Motion Controller Board

Stepper Motor Module

Manufacturer: Precision Micro Control Corporation
3555 Aero Court
San Diego, CA 92123
(619) 565-1500

Vendor: Acquired directly from manufacturer

Part Number: DCX-MC150

Description: Plug-in module for open loop stepper motor control

Data Acquisition Board

Manufacturer: Data Translation Inc.
100 Locke Drive
Marlboro, MA 01752-1192
(617) 481-3700

Vendor: Acquired directly from manufacturer

Part Number: DT-2821

Description: 8 channel differential of 16 channel single ended 12-bit A/D converters, 2 12-bit D/A converters and 2 8-bit digital I/O ports

Stepper Motor and Drive Unit

Manufacturer: Oriental Motor U.S.A., Corp.
Head Office

2701 Plaza Del Amo, Suite 702
Torrence, CA 90503
(213) 515-2264

Vendor: EMCO, Inc.
P.O.Box 5618
Greenville, SC 29606
(803) 232-7616

Part Number: PH268-21

Description: Single Shaft

Solenoid Valves

Manufacturer: Clippard Instrument Laboratory, Inc.
7390 Colerain Road
Cincinnati, OH 45239
(513) 521-4261

Vendor: Barker Air & Hydraulics, Inc.
211 Eisenhower Drive
Greenville, SC 29606
(803) 271-4910

Part Number: EMC-12-24-40

Description: Electronic Manifold Card with 12 3-way solenoid
valves operating on 24 V

Proximity Sensor (I.P.S.) (Inductor Proximity Sensor)

Manufacturer:

Vendor: Mr. Frank Murdoch
Seltrol Corp.
P.O. Box 17739
Greenville, SC 29606

Part Number: BI-G18K-an6X

Description: 3 wire DC
 10 - 30 VDC power supply
 NPN Sinking
 Shielded (ie may be flush mounted in metal)
 Barrel Length = 30mm
 Barrel Diameter = 18mm
 Nominal Sensing Range = 5mm

Bearings

Manufacturer: Fafnir Bearings
 Div. The Torrington Company
 New Britain, CT 06050

Vendor: Dixie Bearings, Inc.
 215 McGee Road
 Anderson, SC 29621
 (803) 225-3791

Description: Angular Contact Ball Bearings

A :	B :
-7201 B.TVP	-Deep Groove
-7306 B.TVPUO	-Ball Bearings
-7263 B.TVP	-4202 B.TVIL
C :	D :
-Lock Nuts	-Lock Washerss
-Extraction Nuts	-MB1
-KM1	-MB2
-KM2	-MB6
-KM6	

Rotary Actuator

Manufacturer: Fafnir Bearings
 Div. The Torrington Company
 New Britain, CT 06050

Vendor: Dixie Bearings Inc.
 215 McGee Road
 Anderson, SC 29621
 (803) 225-3791

Part Number: PT-196-090-A1C1V

Timing Pulley

Manufacturer: Gates Rubber Company

990 South Broadway
P.O. Box 5887
Denver, Colorado 80217

Vendor:

Part Number: PD-19 #100 Type - D

Description: Timing Pulley

Part Number: PA-900H-100

Description: Positive Drive Belts

Harmonic Drive

Manufacturer:

Vendor: John Murray
P.O.Box 58911
(617) 245-7802

Part Number: SC-60

Description:

Appendix E

Electrical Wiring Diagrams

This appendix contains circuit diagrams for the stepper motor and solenoid valves to controller interfaces.

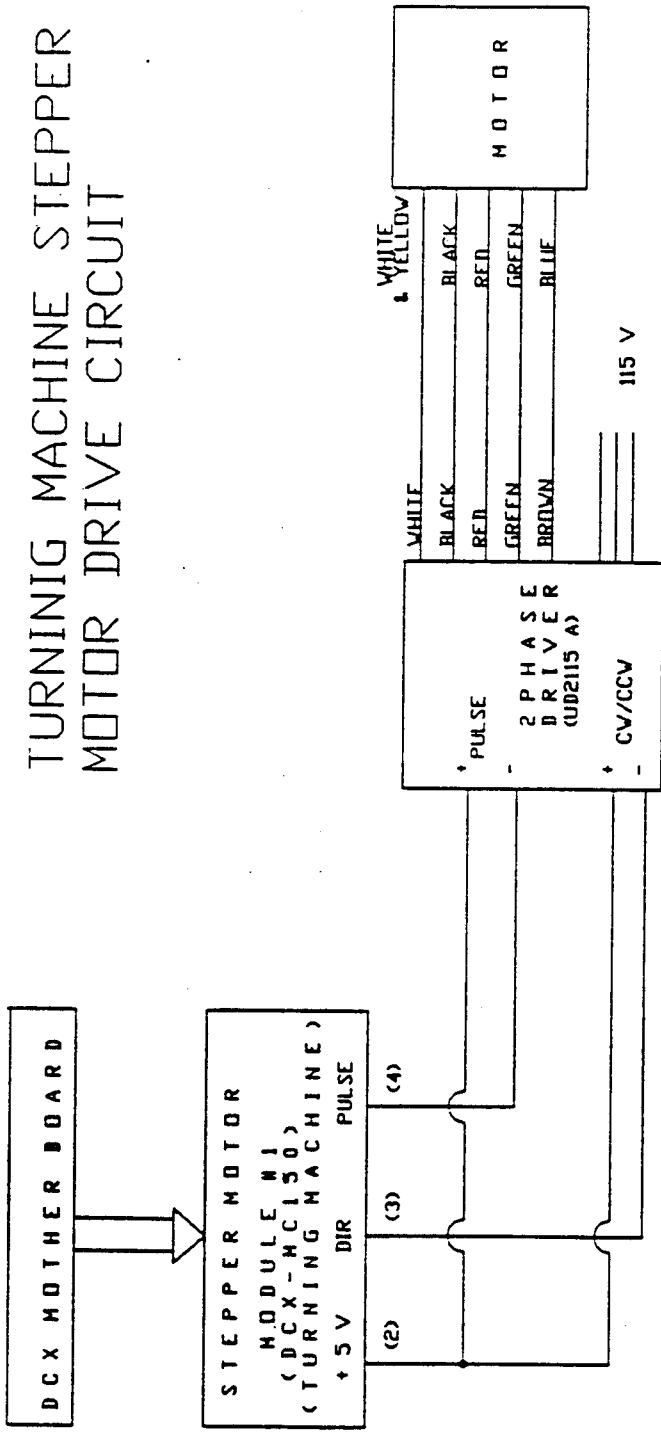

Figure E.1: Turning Machine Stepper Motor Drive Circuit

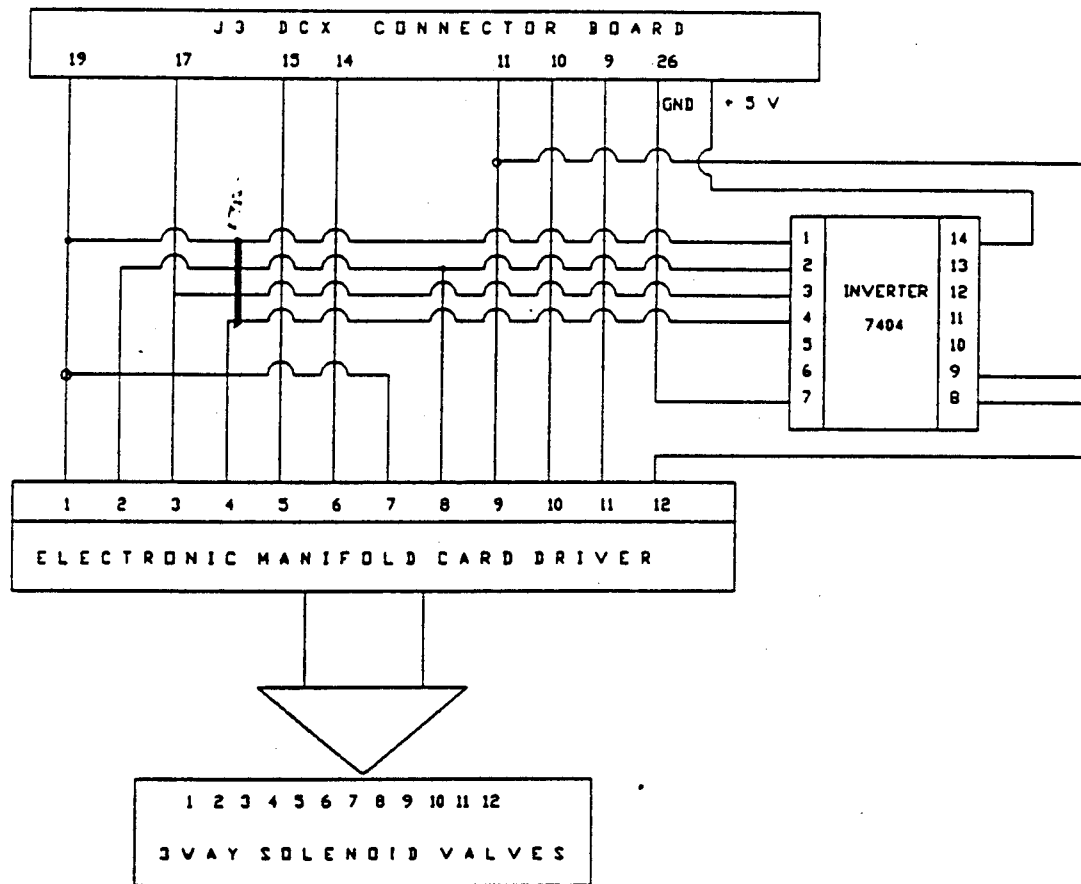

Figure E.2: Pneumatic Valve Drive Circuit

Appendix F

Assembly Drawings

The following drawings describe the turner machine.

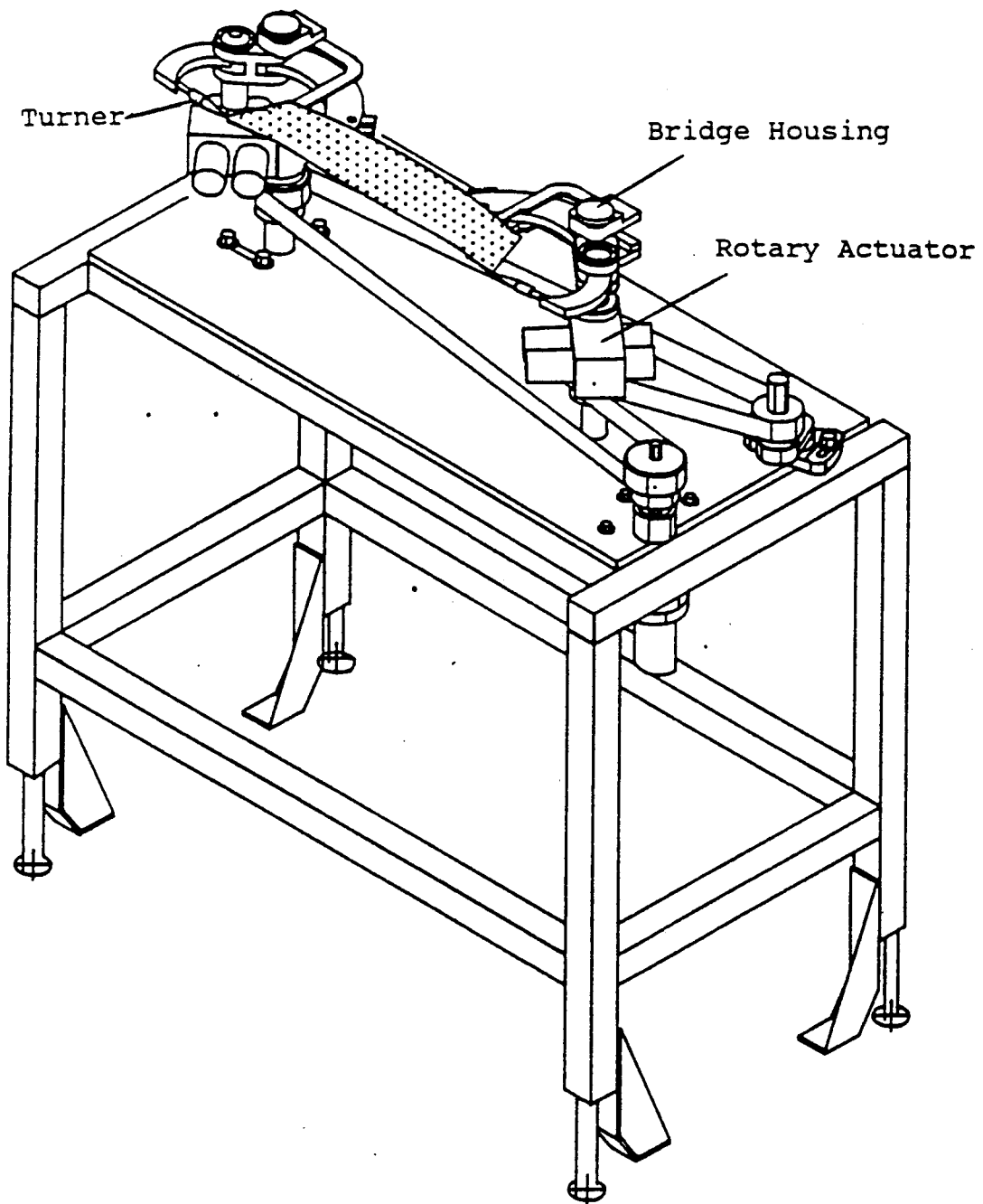

Figure F.1: Pivot Turner in 3-D

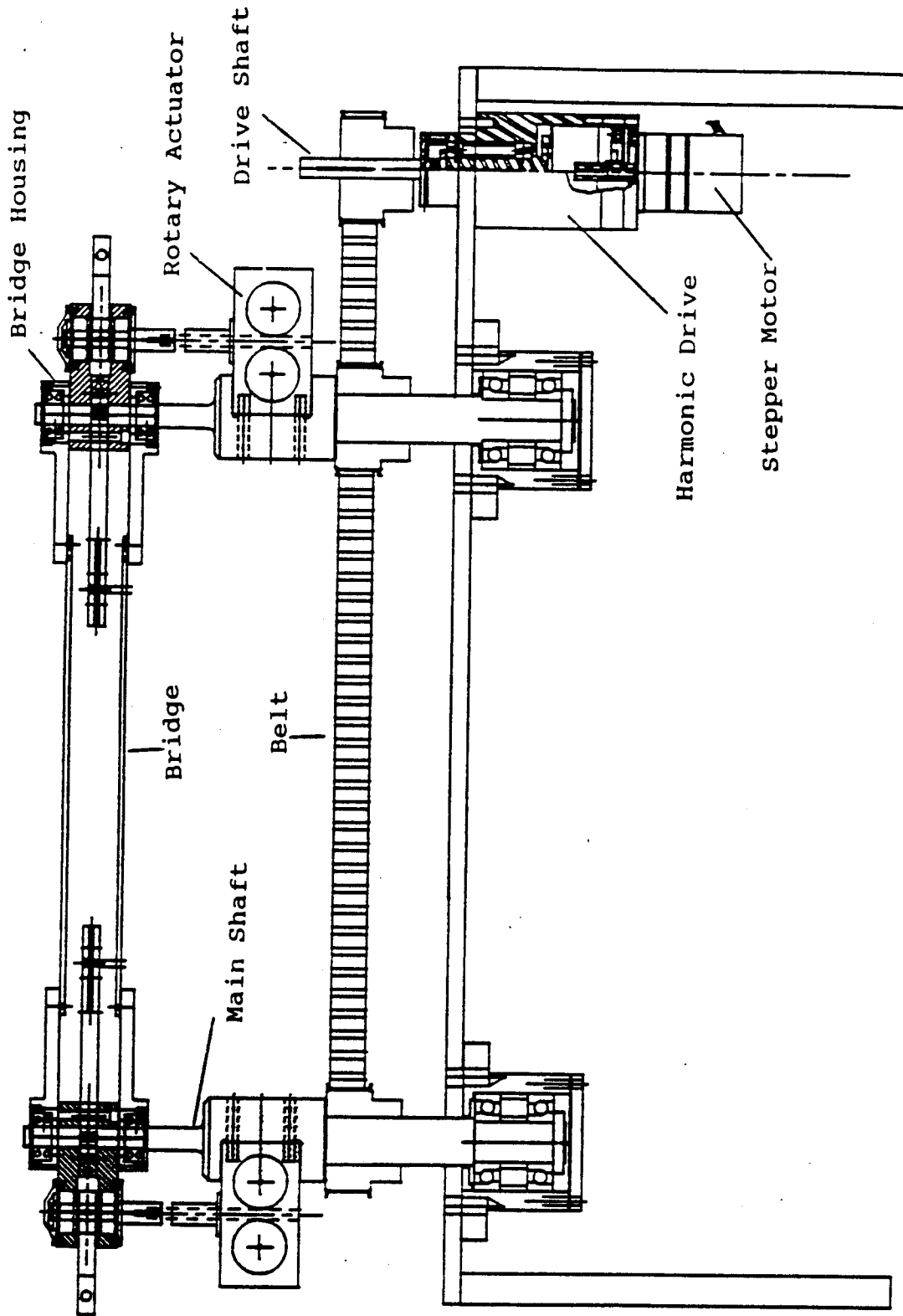

Figure F.2: Cross Section of the Pivot Turner

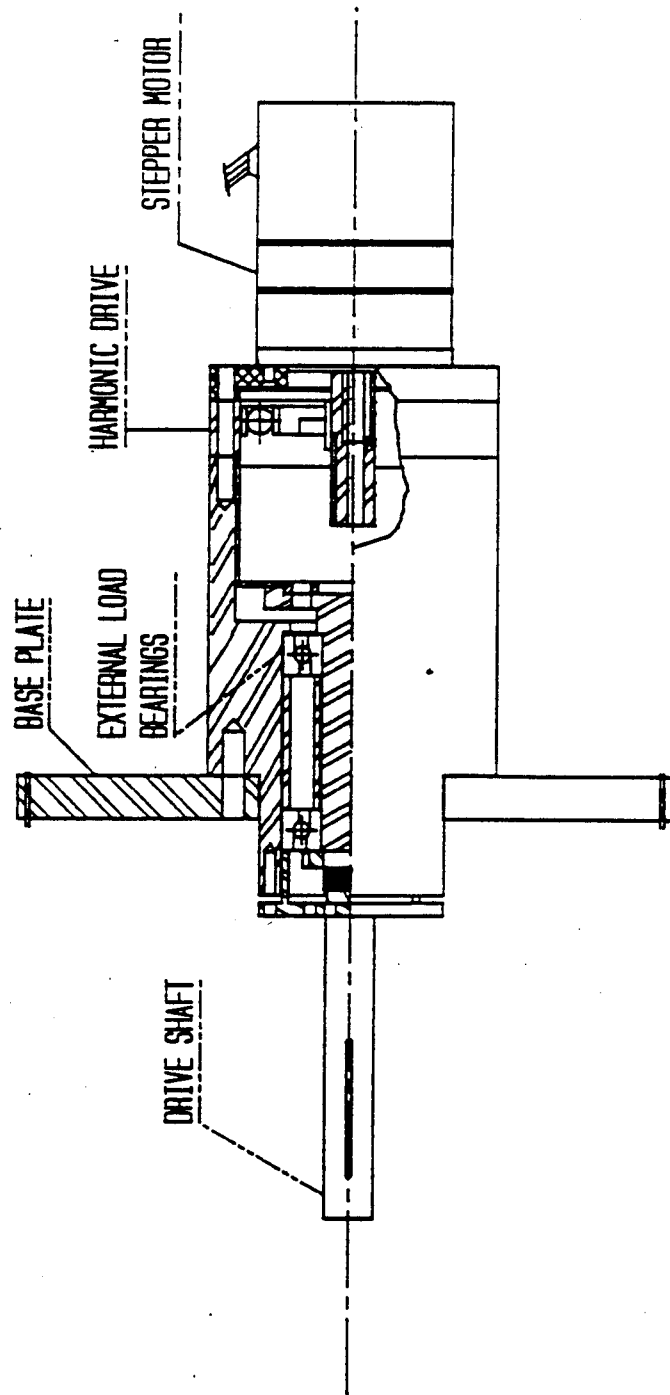

Figure F.3: Cross Section of the Drive Unit

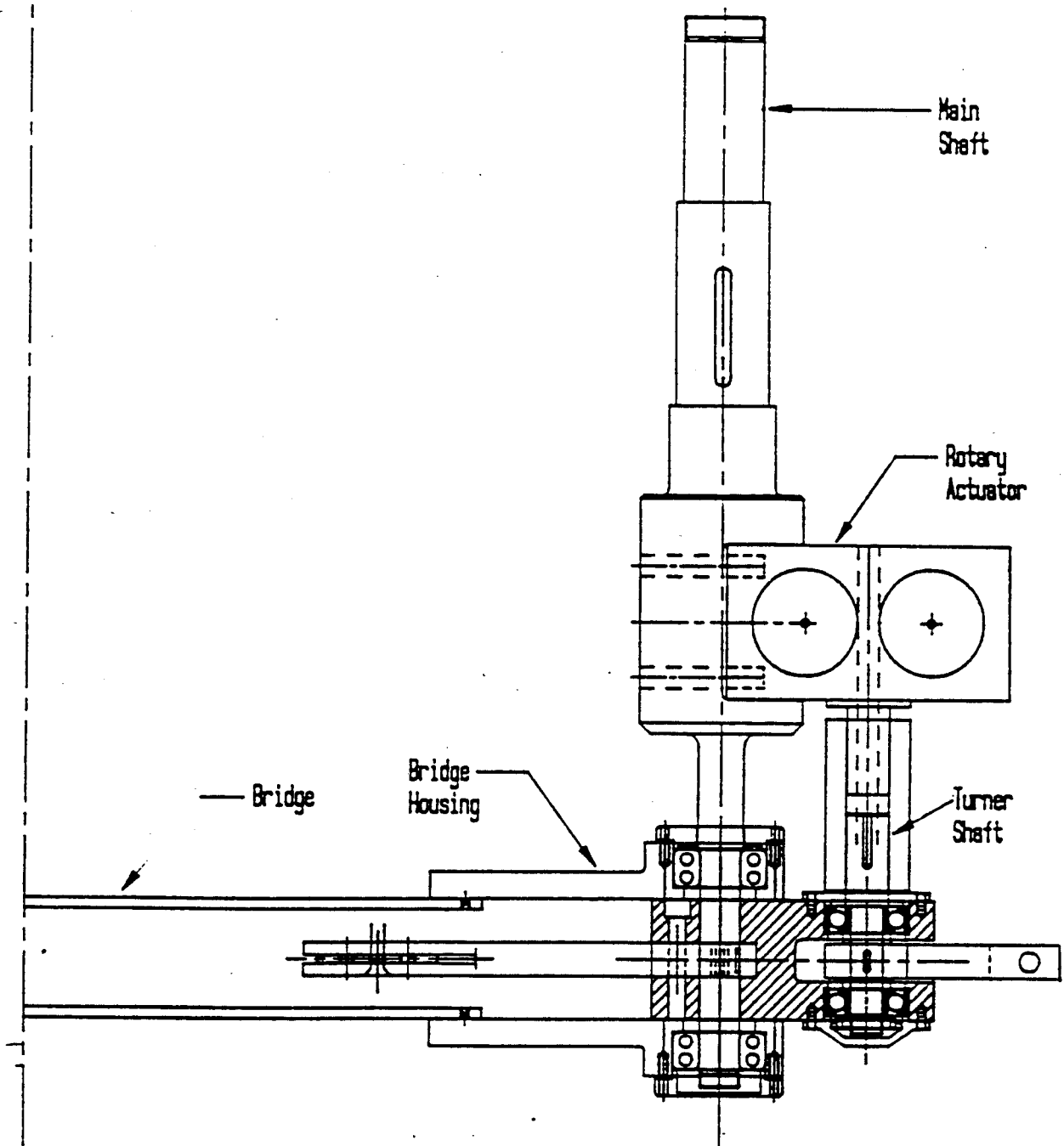

Figure F.4: Front View Showing the Rotary Actuator

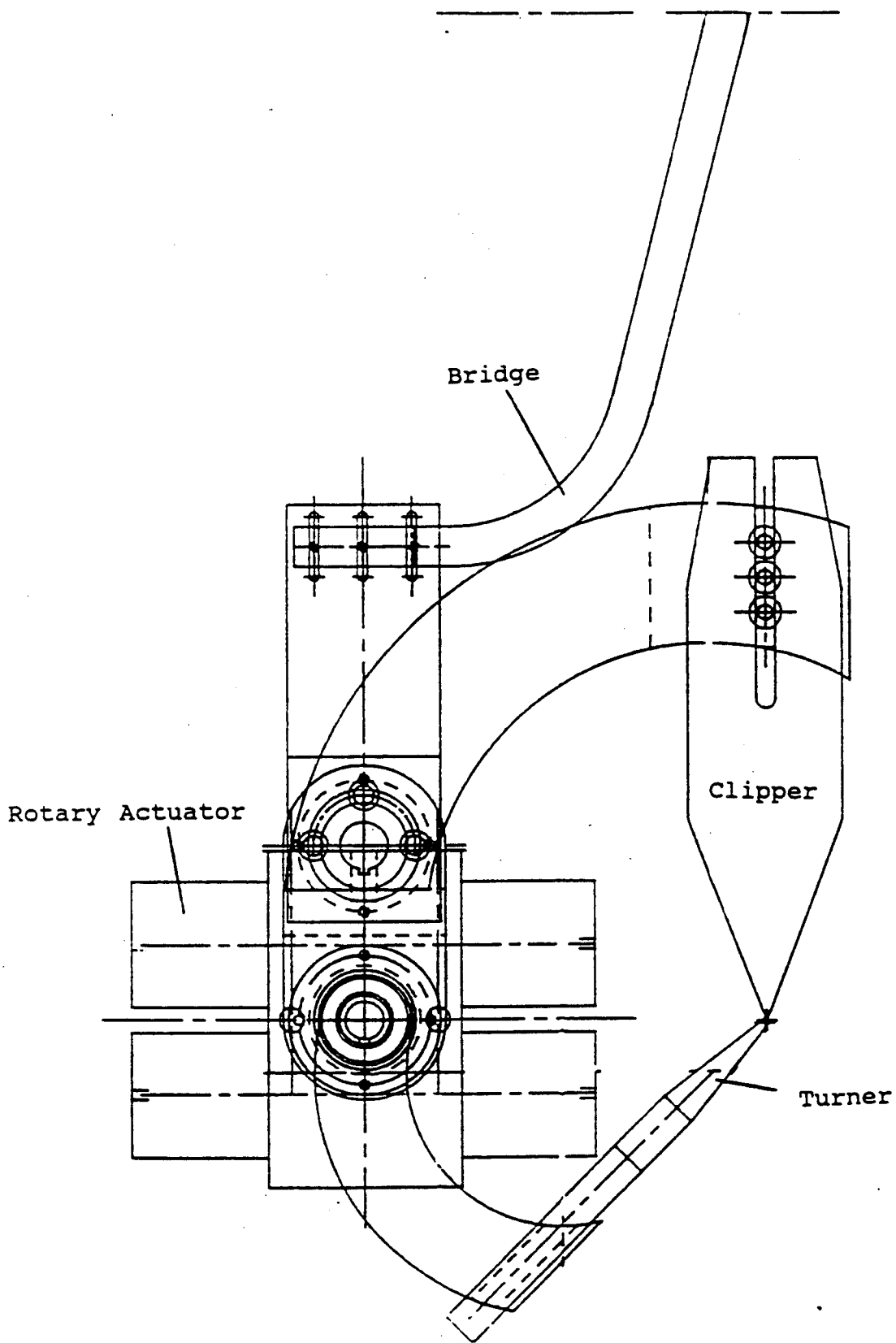

Figure F.5: C-Shape Bracket Assembly

REFERENCES

1. Wicox and Gibbs Inc., Sumbrand Catalog.
2. Luna Industrial Co. LTD., Lunapress-Service Manual, Taiper, Taiwan.
3. Mabie, H.H. and F.W. Ocvirk, Mechanisms and Dynamics of Machinery, John Wiley and Sons, 1978.
4. Gopalswamy, A., Design and Control of a Robot End-Effector for Three Dimensional Manipulation of Multiple-Ply Apparel Workpieces, M.S. Thesis, Mechanical Engineering Department, Clemson University, Clemson, SC, December 1990.
5. Torgerson, E.J., A Hierarchical Semi-Autonomous Control Scheme for Robot -Assisted Workstations, PhD. Thesis, Mechanical Engineering Department, Clemson University, Clemson, S.C., December 1991.
6. Subba-Rao, K., Vision-Assisted Edge Alignment for the Automated Pressing of Two-Dimensional Apparel Components, M.S. Thesis, Mechanical Engineering Department, Clemson University, Clemson, SC, August 1991.
7. Manual Number 87 UMDU-1, Super vexta's UMD Motor/Driver Package, Instruction Manual for UMD Motor/Driver.