

**ROBOT ASSISTED MATERIAL HANDLING
FOR SHIRT COLLAR MANUFACTURING**

**AUTOMATED SHIRT COLLAR
MANUFACTURING**

DLA 900-87-0017 Task 0004

**CENTER FOR ADVANCED
MANUFACTURING**

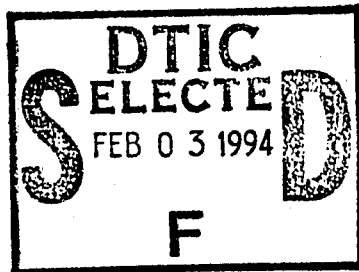

***Original contains color
plates: All DTIC reproductions
will be in black and
white***



**CLEMSON
UNIVERSITY**

**College of Engineering
Clemson, South Carolina 29634**

DTIC QUALITY INSPECTED 3

This document has been approved
for public release and sale; its
distribution is unlimited.

**ROBOT ASSISTED MATERIAL HANDLING
FOR SHIRT COLLAR MANUFACTURING**

**AUTOMATED SHIRT COLLAR
MANUFACTURING**

DLA 900-87-0017 Task 0004

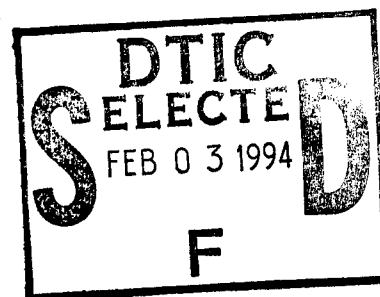

FINAL REPORT

Volume I:

Executive Project Review and Summary

19950130 022

**Frank W. Paul
Principal Investigator**

**Center for Advanced Manufacturing
and
Clemson Apparel Research**

**Clemson University
Clemson, South Carolina**

This document has been approved
for public release and sale; its
distribution is unlimited.

September 1994

REPORT DOCUMENTATION PAGE					
1a. REPORT SECURITY CLASSIFICATION Unclassified			1b. RESTRICTIVE MARKINGS		
2a. SECURITY CLASSIFICATION AUTHORITY		3. DISTRIBUTION/AVAILABILITY OF REPORT Unclassified Distribution Unlimited			
2b. DECLASSIFICATION/DOWNGRADING SCHEDULE					
4. PERFORMING ORGANIZATION REPORT NUMBER(S)			5. MONITORING ORGANIZATION REPORT NUMBER(S)		
6a. NAME OF PERFORMING ORGANIZATION Clemson University Clemson Apparel Research		6b. OFFICE SYMBOL (if applicable)	7a. NAME OF MONITORING ORGANIZATION Defense Personnel Support Center		
6c. ADDRESS (City, State, and ZIP Code) 500 Lebanon Road Pendleton, SC 29670			7b. ADDRESS (City, State, and ZIP Code) 2800 South 20th Street PO Box 8419 Philadelphia, PA 19101-8419		
8a. NAME OF FUNDING/SPONSORING ORGANIZATION Defense Logistics Agency		8b. OFFICE SYMBOL	9. PROCUREMENT INSTRUMENT IDENTIFICATION NUMBER DLA 900-87-D-0017 Delivery Order 0004		
8c. ADDRESS (City, State, and ZIP Code) Room 4B195 Cameroo Station Alexandria, VA 22304-6100			10. SOURCE OF FUNDING NUMBERS		
			PROGRAM ELEMENT NO. 78011S	PROJECT NO.	TASK NO.
11. TITLE (Include Security Classification) Automated Shirt Collar Manufacturing Volume I: Executive Project Review and Summary - unclassified					
12. PERSONAL AUTHOR(S) Frank W. Paul, Principal Investigator					
13a. TYPE OF REPORT Final		13b. TIME COVERED FROM TO		14. DATE OF REPORT (year, Month, Day) 1992 June 23	15. PAGE COUNT
16. SUPPLEMENTARY NOTATION					
17. COSATI CODES			18. SUBJECT TERMS (Continue on reverse if necessary and identify by block number)		
FIELD	GROUP	SUB-GROUP			
19. ABSTRACT (Continue on reverse if necessary and identify by block number) This document presents Volume I of the report on research into automated shirt collar manufacturing. It provides the executive review and summary of the project, as detailed in Volumes II, III, IV, V and VI of this project.					
20. DISTRIBUTION/AVAILABILITY OF ABSTRACT <input checked="" type="checkbox"/> UNCLASSIFIED/UNLIMITED <input type="checkbox"/> SAME AS RPT. <input type="checkbox"/> OTIC USERS			21. ABSTRACT SECURITY CLASSIFICATION Unclassified		
22a. NAMES OF RESPONSIBLE INDIVIDUAL Frank W. Paul			22b. TELEPHONE (Include Area Code) (803) 656-3291	22c. OFFICE SYMBOL	

ACKNOWLEDGMENTS

The Principal Investigator would like to thank the Defense Logistics Agency, Department of Defense for support of this work under Contract Number DLA 900-87-0017 Task 0004. This work was conducted through Clemson Apparel Research for the advancement of apparel manufacturing technology by the Center for Advanced Manufacturing, Clemson University.

Accession For	
NTIS CRA&I	<input checked="" type="checkbox"/>
DTIC TAB	<input type="checkbox"/>
Unannounced	<input type="checkbox"/>
Justification _____	
By _____	
Distribution/	
Availability Codes	
Dist	Avail and/or Special
A-1	

TABLE OF CONTENTS

	Page
INTRODUCTION	1
Automated Collar Turning and Pressing	1
AUTOMATED COLLAR TURNING AND PRESSING WORKSTATION.....	1
Apparel End-Effector Technology	2
Double-point Turning Machine Technology	2
Edge Alignment/Pressing Machine Technology	3
Integrated Workstation Control and Operation	3
CONCLUSIONS	4

LIST OF FIGURES

Figure	Page
1. Collar-turning and Pressing Machine	5
2. AAW Configuration.....	6
3. Collar-handling End-effector	7
4. Double-point Turning Machine	7
5. Quality of the Collar Point	8
6. Shirt-collar Pressing on the Lunapress	9
7. Indirect Seam Alignment - Single-ply manipulation	10
8. Proof-of-concept Machine	11
9. A Visual Comparison of Pressed Collars	12
10. Apparel Assembly Workstation	13
11. Workstation Configuration	14
12. Workstation Control Scheme	15
13. Organization of Databases and Rule-bases	16
14. Device Loading	17

ADVANCED AUTOMATION FOR SHIRT-COLLAR TURNING AND PRESSING

INTRODUCTION

This project work was initiated with the interest of addressing the technology needed to automate shirt-collar turning and pressing. Shirt-collar turning and pressing processes are currently performed by manual operators on a variety of industrial machines which use a single-point turning and pressing process. This work was undertaken by a team of graduate research assistants and the principal investigator under the review of an advisory board composed of representatives from the apparel industry and academic community.

Automated Collar Turning and Pressing

The current practice of manual turning and pressing depends on skilled machine operators to turn the collar inside out while "pointing" the collar, and aligning the collar seam edges for pressing prior to run stitching. This operator-assisted process is accomplished for a single collar point at a time in a sequential fashion, as shown in Figure 1. A desirable goal is to automate the turning and pressing of both collar points at the same time to create "double-point" turning and pressing processes. The understanding of these two processes has the potential for creating an evolutionary integrated collar-turning and pressing machine.

The research and development on the turning and pressing processes was accomplished by creating a proof-of-concept systems workstation, where a robot with a limp material-handling end-effector would sequentially load and unload turning and pressing machines based on the double-point concept. Technical solutions for the limp material-handling end-effector, the double-point turning machine, the double-point collar edge alignment/pressing machine, and the systems planning and hierarchical integration of the robot and two machines were addressed in this research.

AUTOMATED COLLAR TURNING AND PRESSING WORKSTATION

The critical technological issues of producing quality collars relates to inverting and pointing the collar, and aligning the collar edge prior to pressing. Producing a quality turned and pressed collar requires a sharp point during the turning process and the proper alignment of the pressed collar edge to achieve a pair of smoothly contoured, sharp and matched collar points.

The development of the double-point turning and pressing technologies focused on individual solutions for each process. These solutions were placed in the context of evaluating the applicability of material-handling robots to apparel manufacturing. This resulted in the development, understanding and evaluation of an apparel workstation composed of a collar destacker, collar turner, collar edge alignment/presser, and robot for collar handling. Figure 2 shows a schematic of the workstation configuration. This workstation included the capability of exploring how computer-based hierarchical control concepts may assist an apparel operator to plan and control workstation activities, including replanning and workstation process error recovery. The following sections address the technology of the robot apparel end-effector, the turning machine, the edge alignment/presser machine, and the control and operation of the workstation system.

Apparel End-Effector Technology

An apparel end-effector designed to handle limp fabric is shown in Figure 3. This end-effector was designed in such a way to acquire both unturned and turned collars, load and unload the turner and presser machines, center the collar, tension the collar fabric for positioning in the machines, and orient the collar in a vertical plane. This device was attached to an Adept 1 industrial robot for collar handling in the workstation. The end-effector controls were integrated into the workstation operation, and included servo and stepper motor positions and gripper operation. All actions of the end-effector were activated through the system supervisory controller which was coordinated with the robot controller, as indicated in Figure 2.

Double-Point Turning Machine Technology

A double-point collar-turning machine was conceived by considering a variety of techniques to invert the collar pocket. These techniques ranged from the use of tubes to vacuums to pivoting mechanisms. The resulting concept was based on double-point pivot turning using pointing elements similar to the clipper and turner components found on commercial single-point turner/presser machines. Figure 4 shows the developed double-point proof-of-concept turning machine.

In excess of 200 collars have been turned with this proof-of-concept machine. Figure 5 shows a comparison of a collar turned single point at a time on a commercial machine with a collar turned both points at a time on the new concept machine. Observation of this Figure shows that the collars have similar geometric points, with some collar "puffing" owing to excess material inside the collar point. An important requirement for the use of this highly productive double-point turning technology will be to ensure the quality of the trimming action on the unturned collar tip prior to the turning operation.

Edge Alignment/Pressing Machine Technology

Figure 6 shows the operator-controlled process of turned collar edge alignment prior to insertion into a commercial turning and pressing machine. This process requires considerable operator hand, finger and eye coordination to ensure that the collar seam edge is correctly positioned with respect to the pressing creaser blade. This process is skill-based and demands a significant amount of operator cycle time and attention to ensure a quality pressed collar. The automation of this process requires the geometric knowledge of the seam collar edge so that it can be physically located with respect to the creaser blade.

An automated edge detection/alignment pressing machine was developed based on vision sensing and indirect rear collar edge matching. This method was selected from several concepts which considered the visual measurement and positioning of the collar seam location with respect to the creaser blade. Figure 7 shows the single-ply manipulation scheme in cross-section. The method requires that the original unturned collar components be precisely sewn together in such a way that the rear collar edges match. This constraint was investigated at the Clemson Apparel Research Shirt-manufacturing Facility and not found to be a limitation to this approach.

Figure 8 shows the edge alignment/presser machine system. This machine includes a collapsible creaser blade which is inserted into the turned collar pocket and then expanded for edge alignment purposes. A vision camera sensor is used to locate the top ply of the collar with respect to the bottom ply. Analysis has indicated that the vision camera sensor can be replaced by an appropriate set of LED sensors for positioning the top ply with respect to the bottom ply. This information is then used by the system supervisory controller to command the three alignment actuators to position the top ply edge with respect to the bottom ply edge. Figure 9 shows a visual comparison of the edge alignment and pressing results with the Clemson proof-of-concept machine (POCM) and a commercial single-point pressing machine.

Integrated Workstation Control and Operation

Figure 10 shows photographs of the apparel workstation developed during this research to study automated double-point turning and pressing. A part of this workstation research was the knowledge and understanding associated with hierarchical control to achieve an acceptable man-machine planning and operating system. Figure 2 shows that significant mechatronic technology is required to plan, integrate, program and operate a workstation system composed of three computers, a robot, end-effector, vision-ranging system, vision-positioning system, turning machine and alignment/pressing machine. The operator interface technology needed to develop a plan and operating software is one of the limitations of most current automated manufacturing technology. Figure 11 shows the "star" computer hardware configuration with a system supervisor which interacts with the operator to plan and operate the system.

The workstation control paradigm used was composed of an off-line planning level, and on-line computer coordination and hardware levels. The scheme for this paradigm is shown in Figure 12. The off-line operator planning software uses an expert system (C/Prolog) for assisting the operator to plan the workstation task required to complete a given job. This man-machine approach to operating a workstation does not require the operator to be an "expert systems" real-time programmer, but requires only his/her knowledge of the workstation operations and sequencing.

The operator is prompted and assisted by the expert-based systems software which is generically configured, as shown in Figure 13. All on-line real-time operational software is structured by the off-line expert system, downloaded to the appropriate computer, compiled (software is written in the C language) and then executed for controlling the workstation operation. The operation of the turning and edge alignment/pressing machines is shown in Figure 14 in conjunction with the material handling of the robot and fabric-handling end-effector. A videotape has been made which documents the real-time system operation.

CONCLUSIONS

The results of this research and development work have created a proof-of-concept workstation composed of *double-point turning and edge alignment/pressing machines*, and a material-handling robot and hierarchical control system which demonstrates the capability of enhancing the automation of shirt-collar manufacturing. The developed technology requires a Phase II continuation to create an integrated turning and pressing prototype machine, which can use industrial robot or operator-assisted loading and unloading. Such a prototype machine should be tested at the Clemson Apparel Research Facility and at a military apparel shirt-manufacturing site to ascertain the practical and economic benefits which may accrue to enhance the productivity of the shirt-manufacturing process.

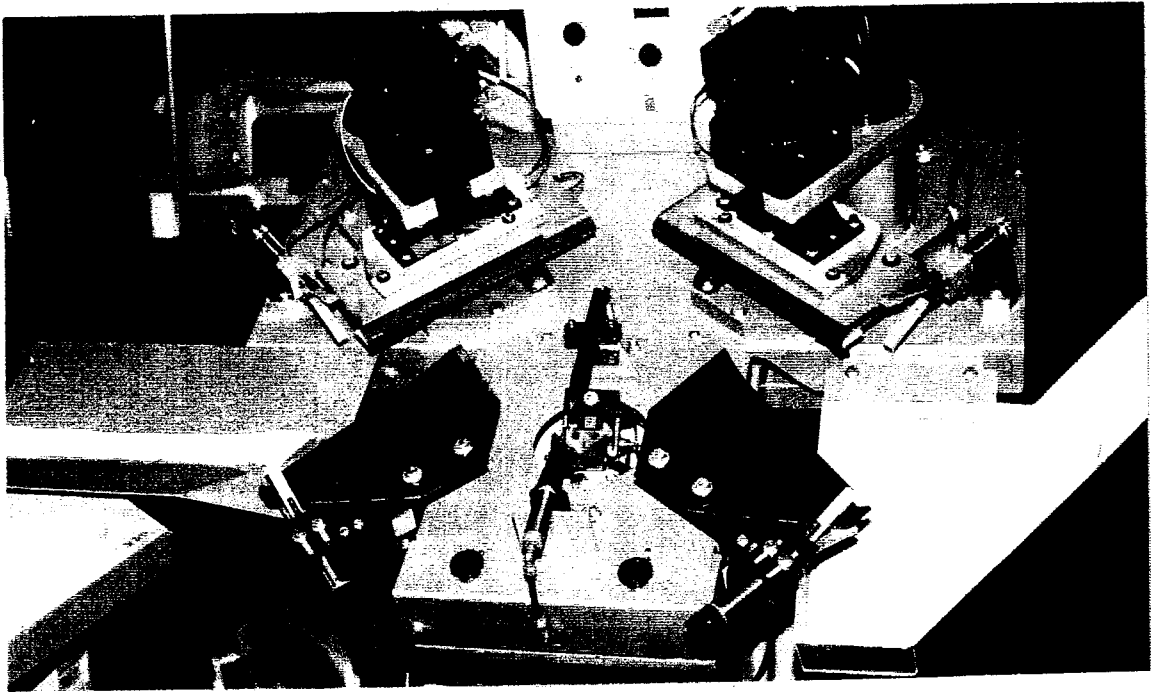

(a) Front view of machine

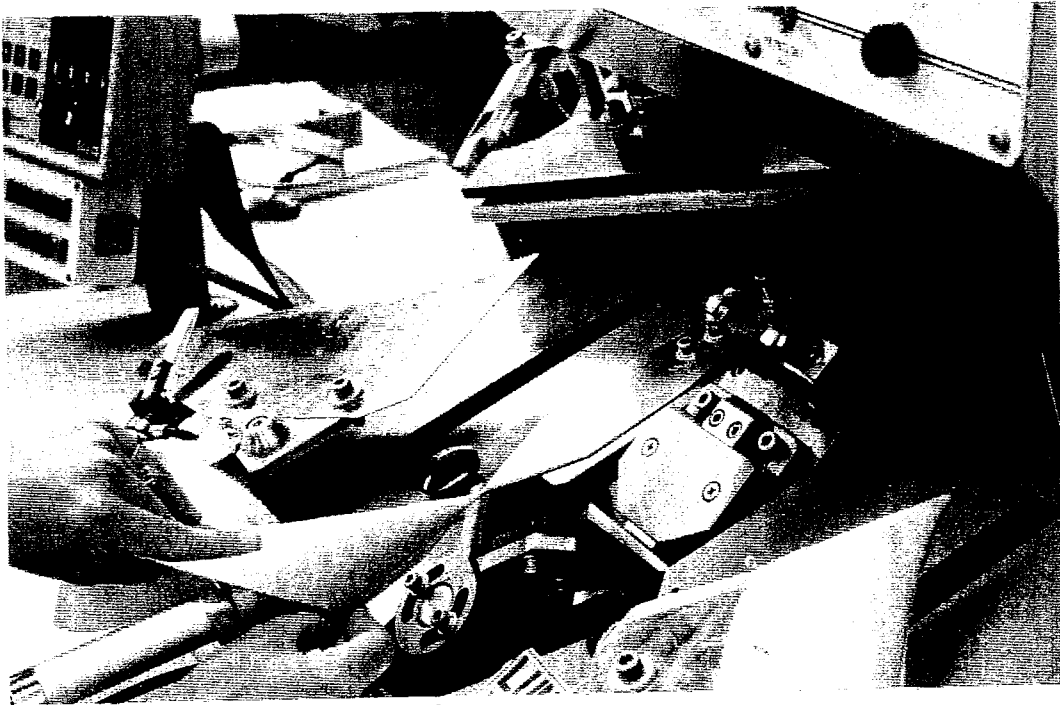

(b) Manual turning operation

Figure 1. Collar-turning and Pressing Machine

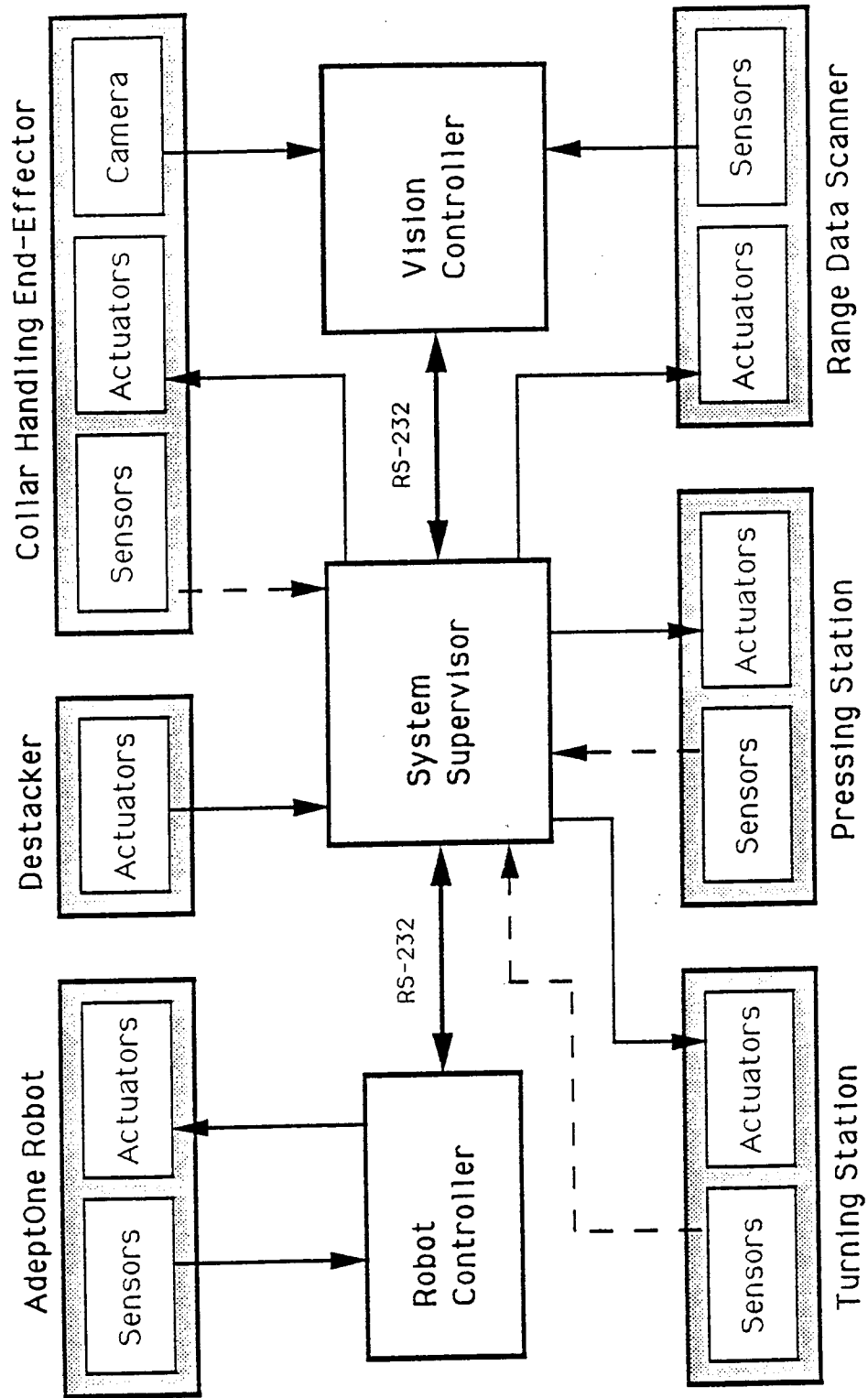

Figure 2. AAW Configuration

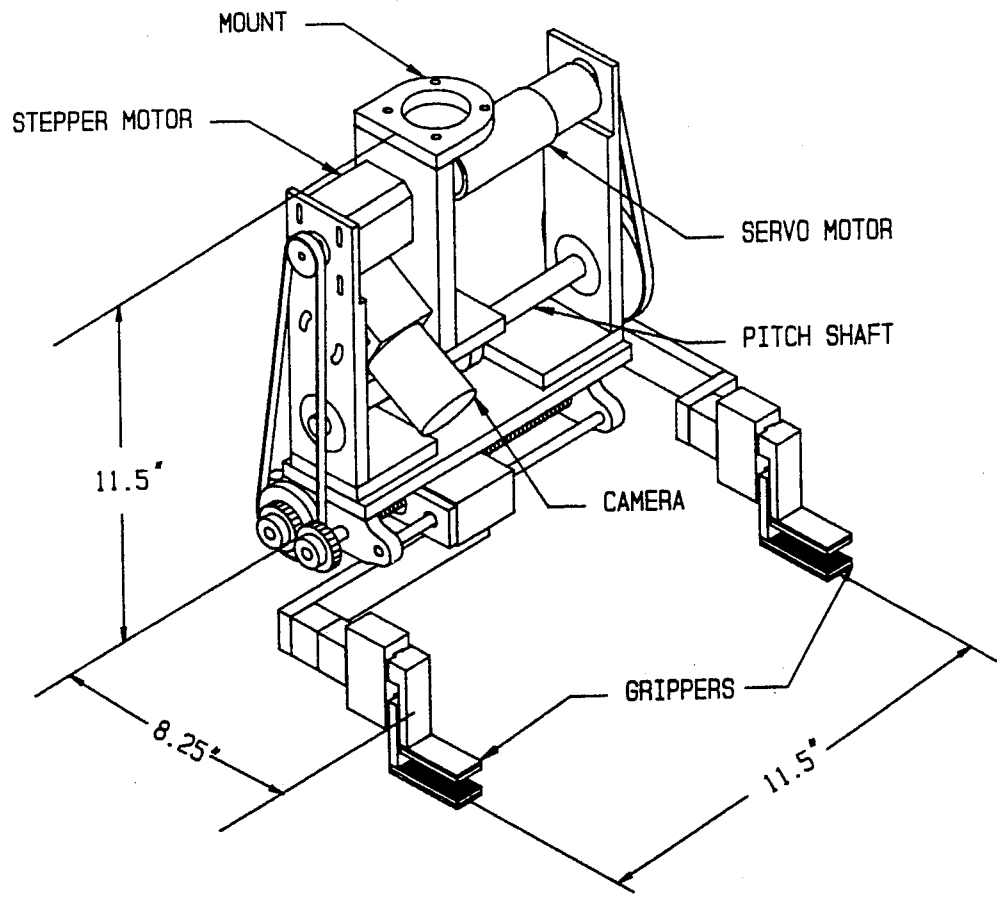

Figure 3. Collar-handling End-effector

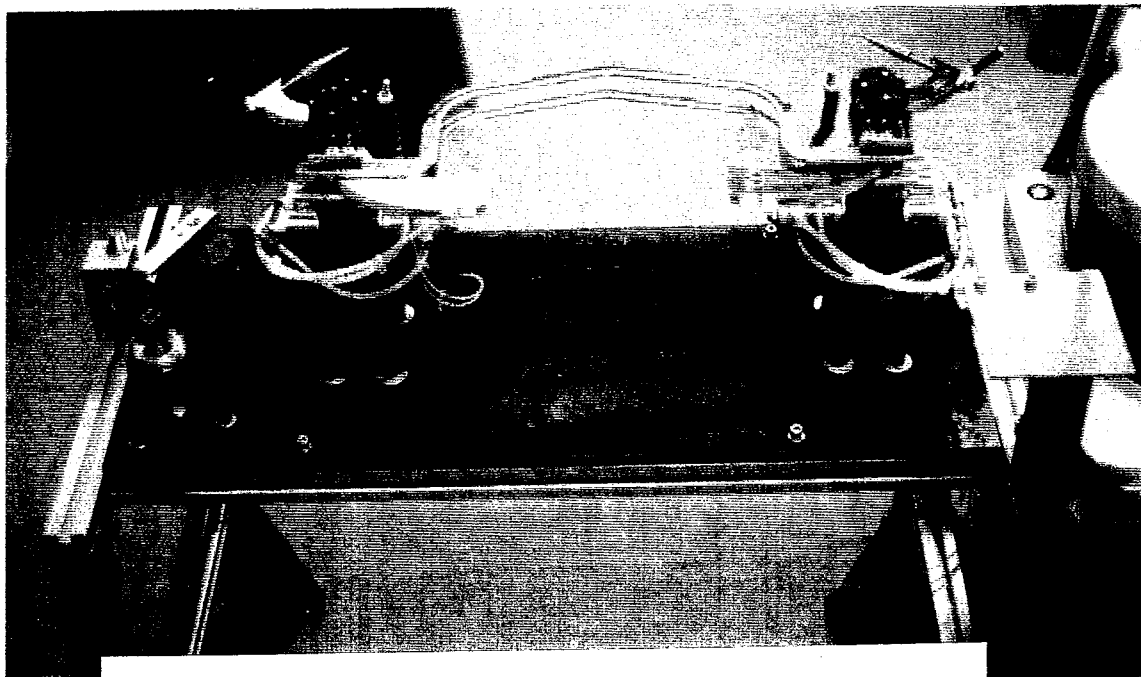
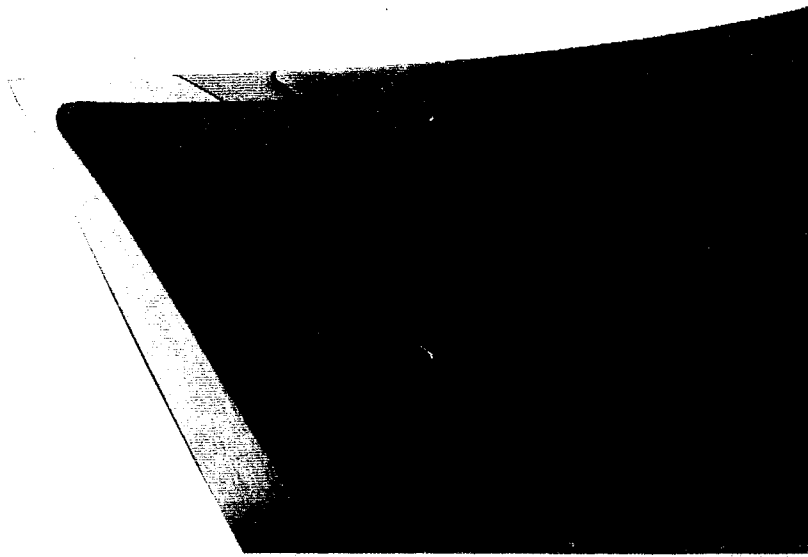
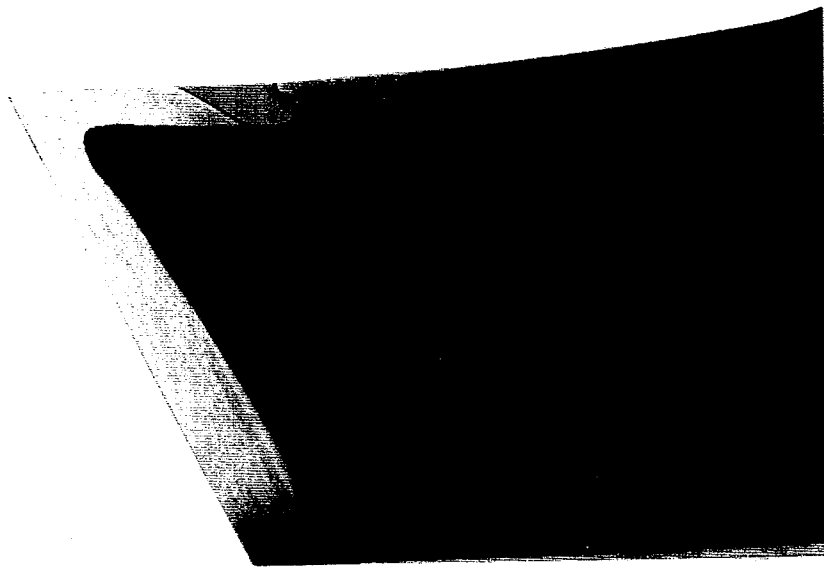

Figure 4. Double-point Turning Machine



(a) The collar turned and pressed on the lunapress



(b) The collar turned on the turner and pressed on the lunapress

Figure 5. Quality of the Collar Point

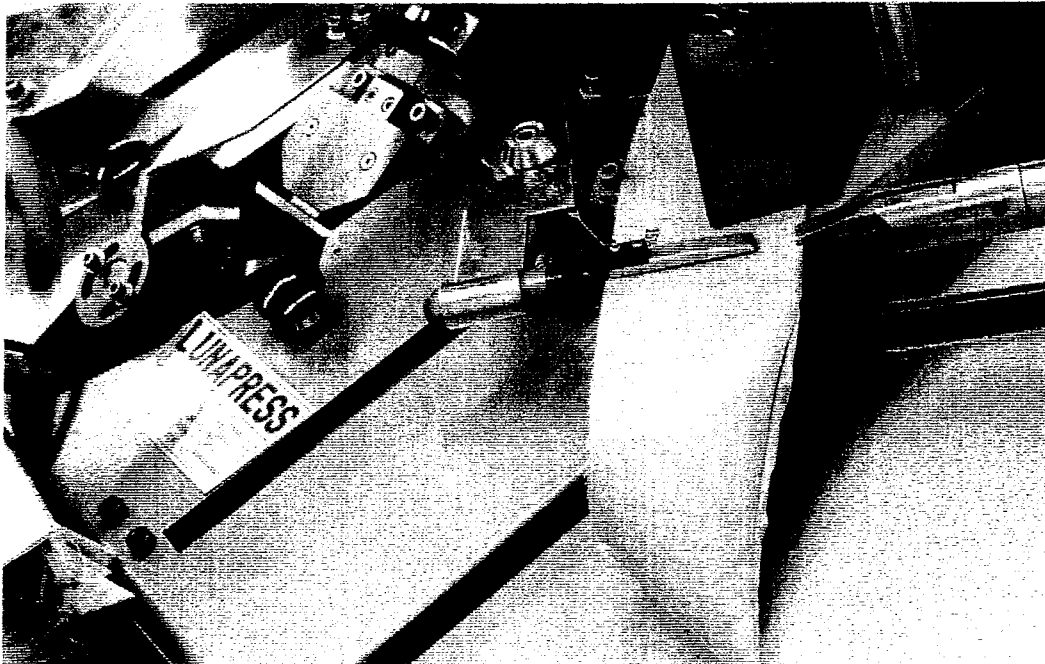
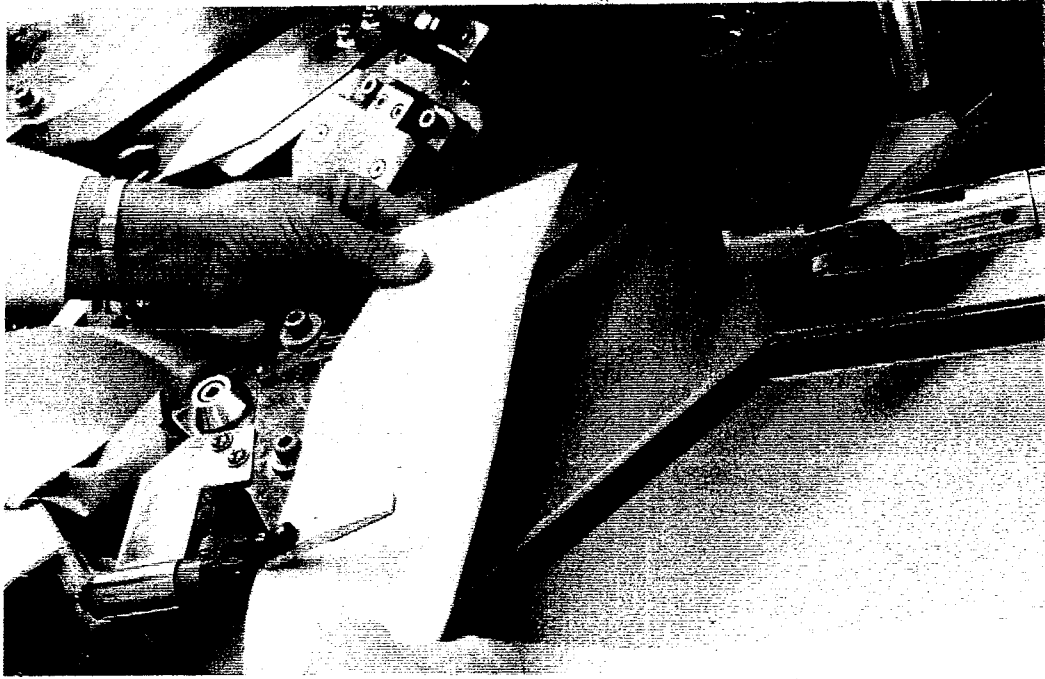
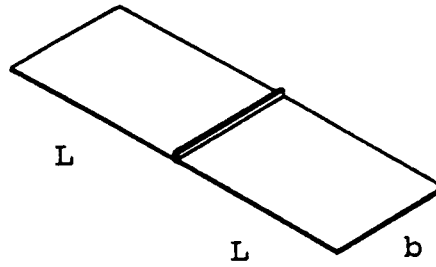

Figure 6. Shirt-collar Pressing on the Lunapress



Apparel Workpiece

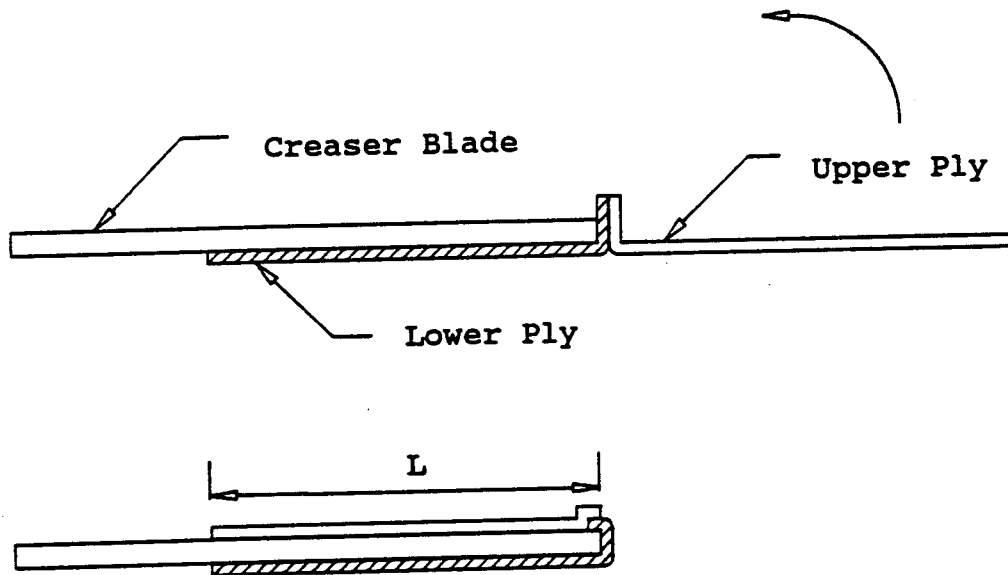

Figure 7. Indirect Seam Alignment - Single-ply manipulation

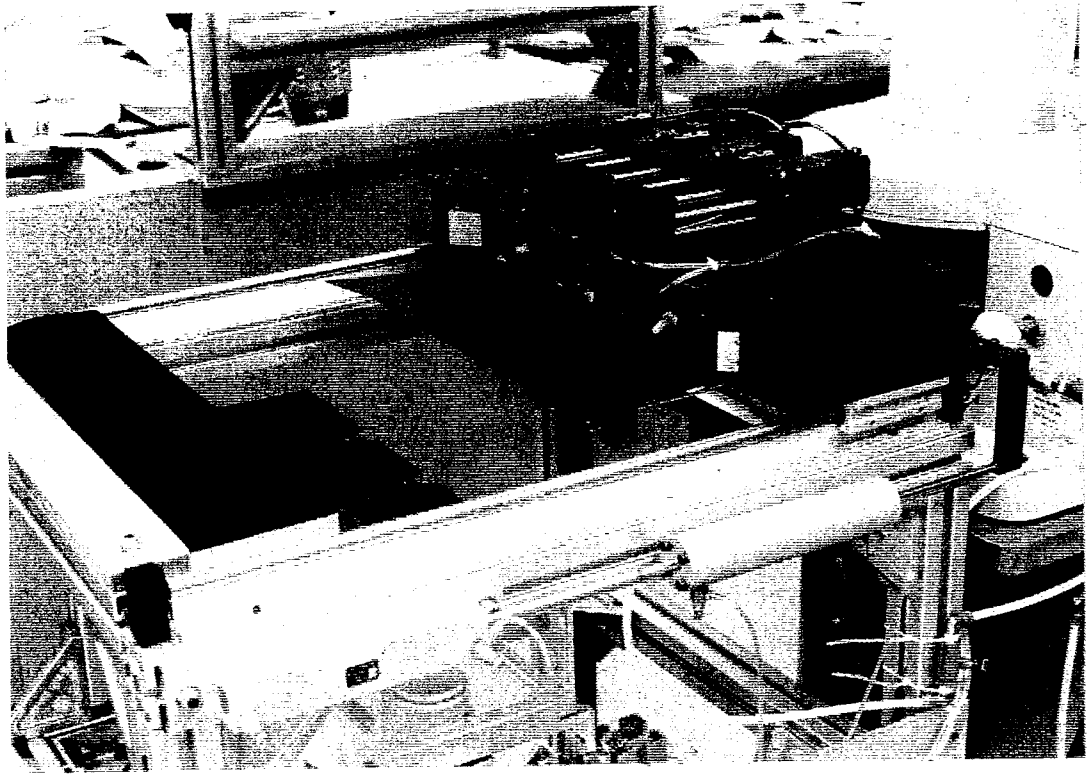

Figure 8. Proof-of-concept Machine

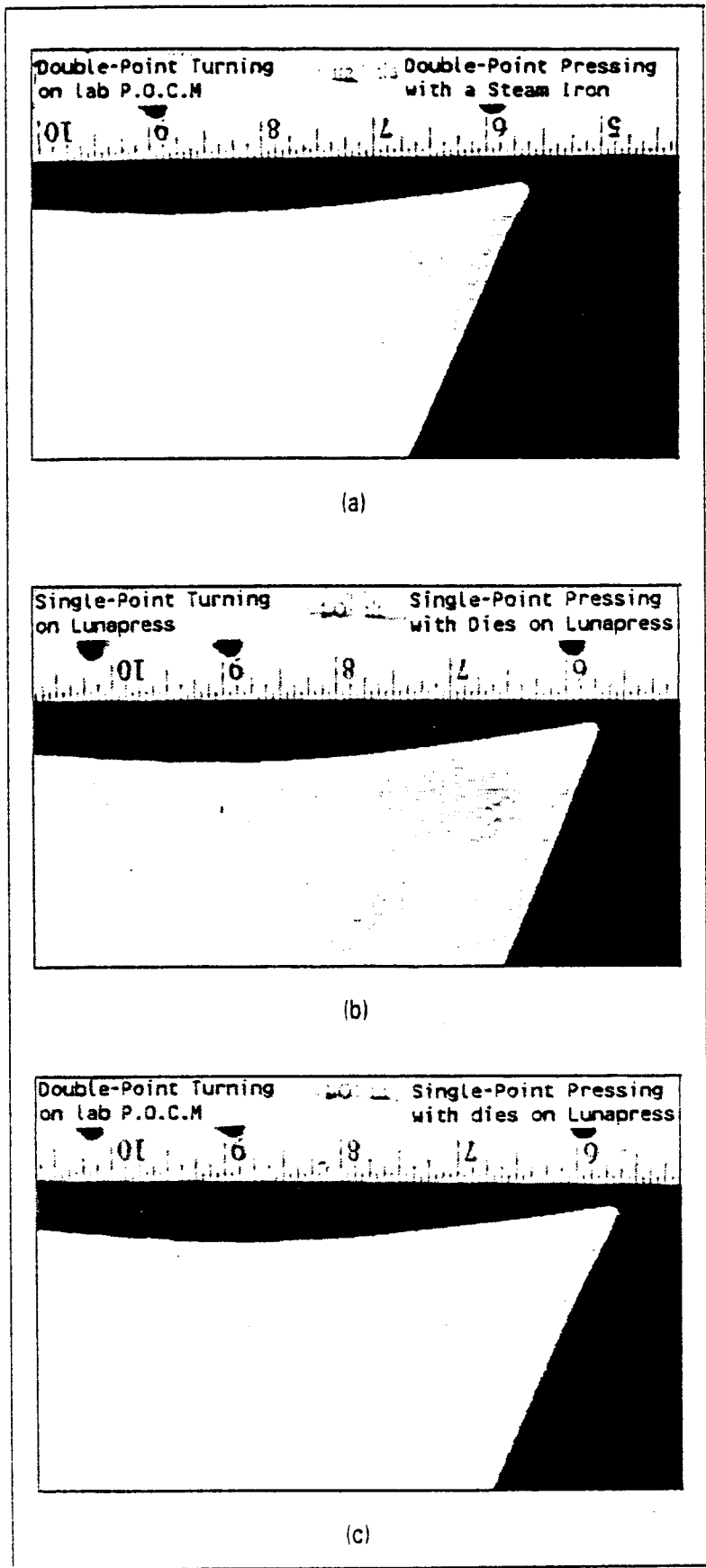

Figure 9. A Visual Comparison of Pressed Collars

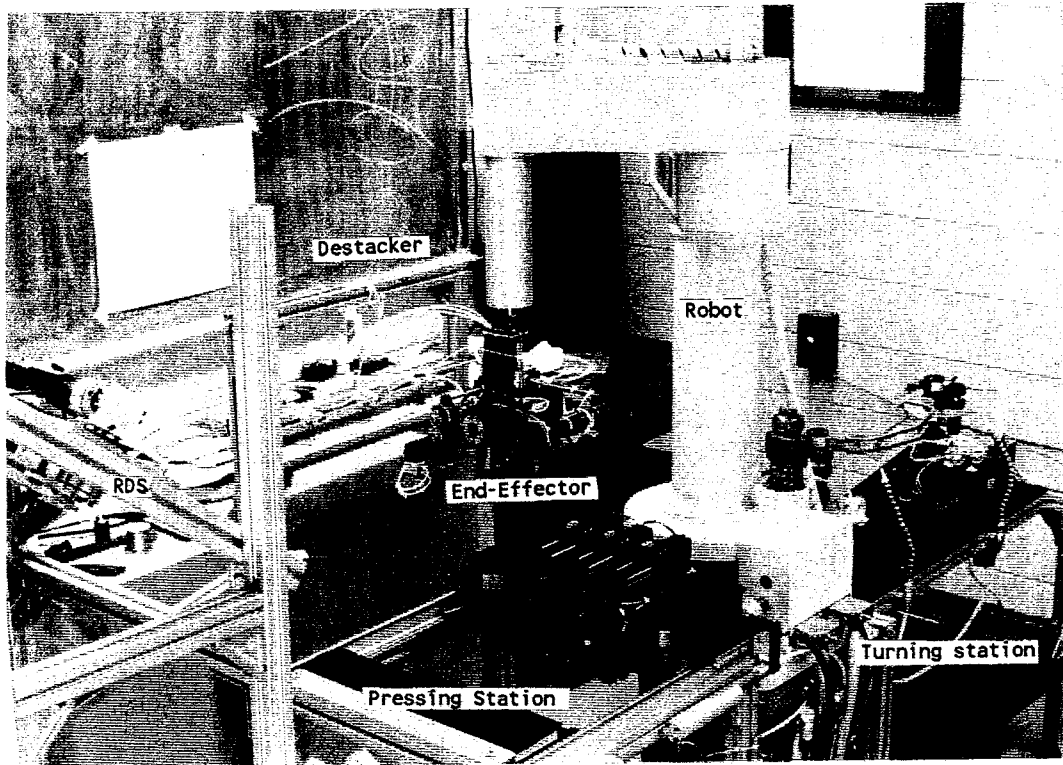

Figure 10. Apparel Assembly Workstation

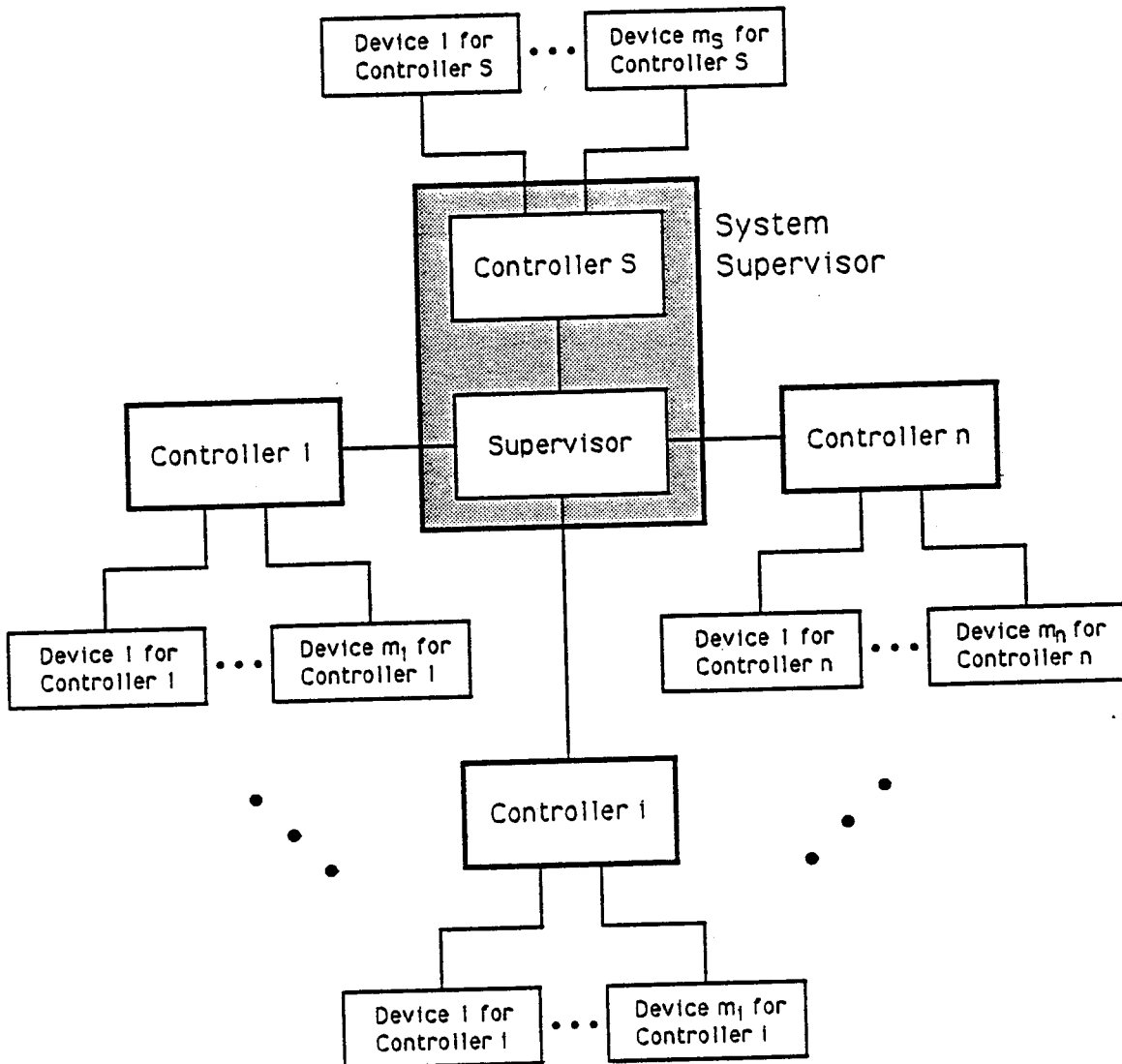

Figure 11. Workstation Configuration

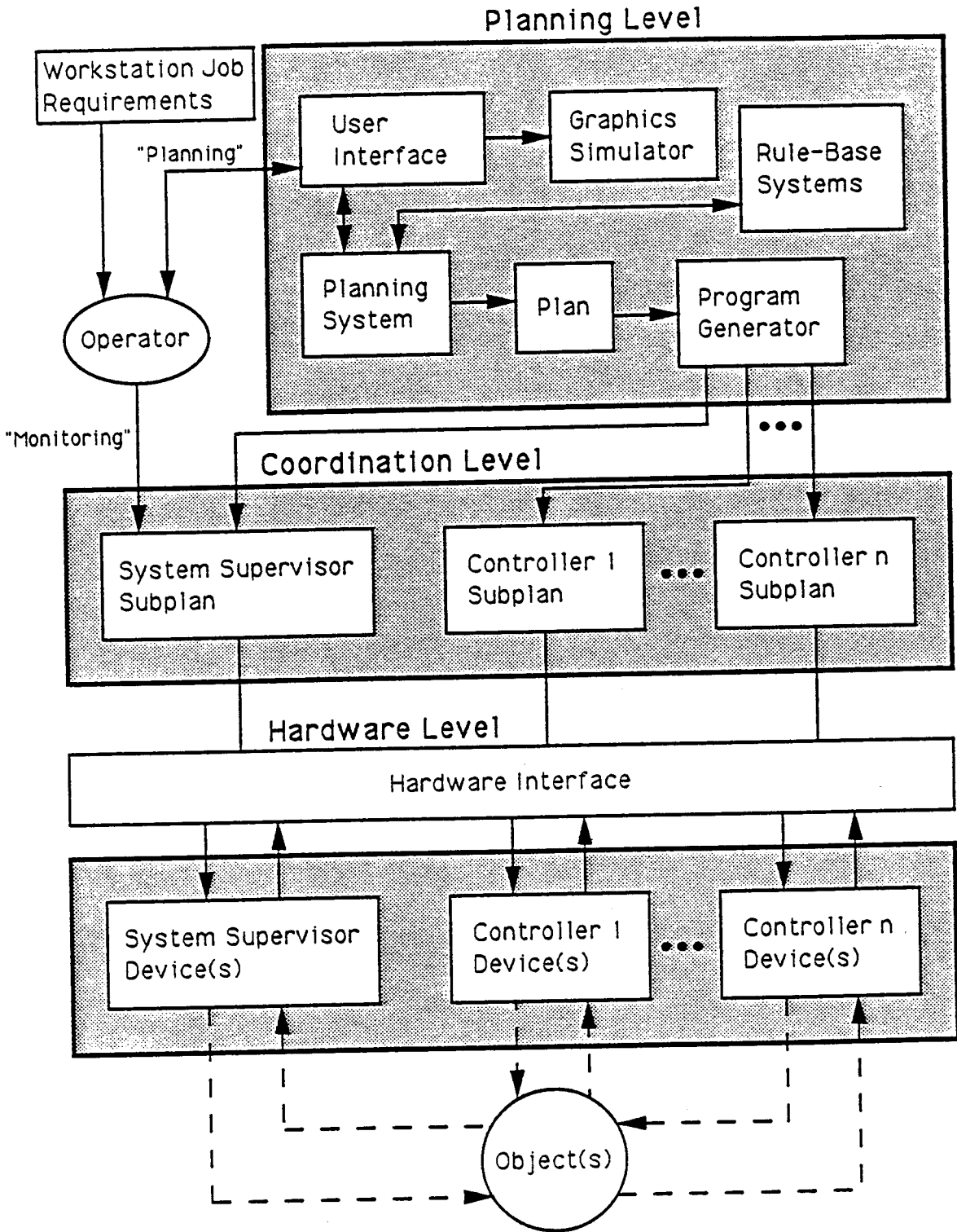

Figure 12. Workstation Control Scheme

FACTS

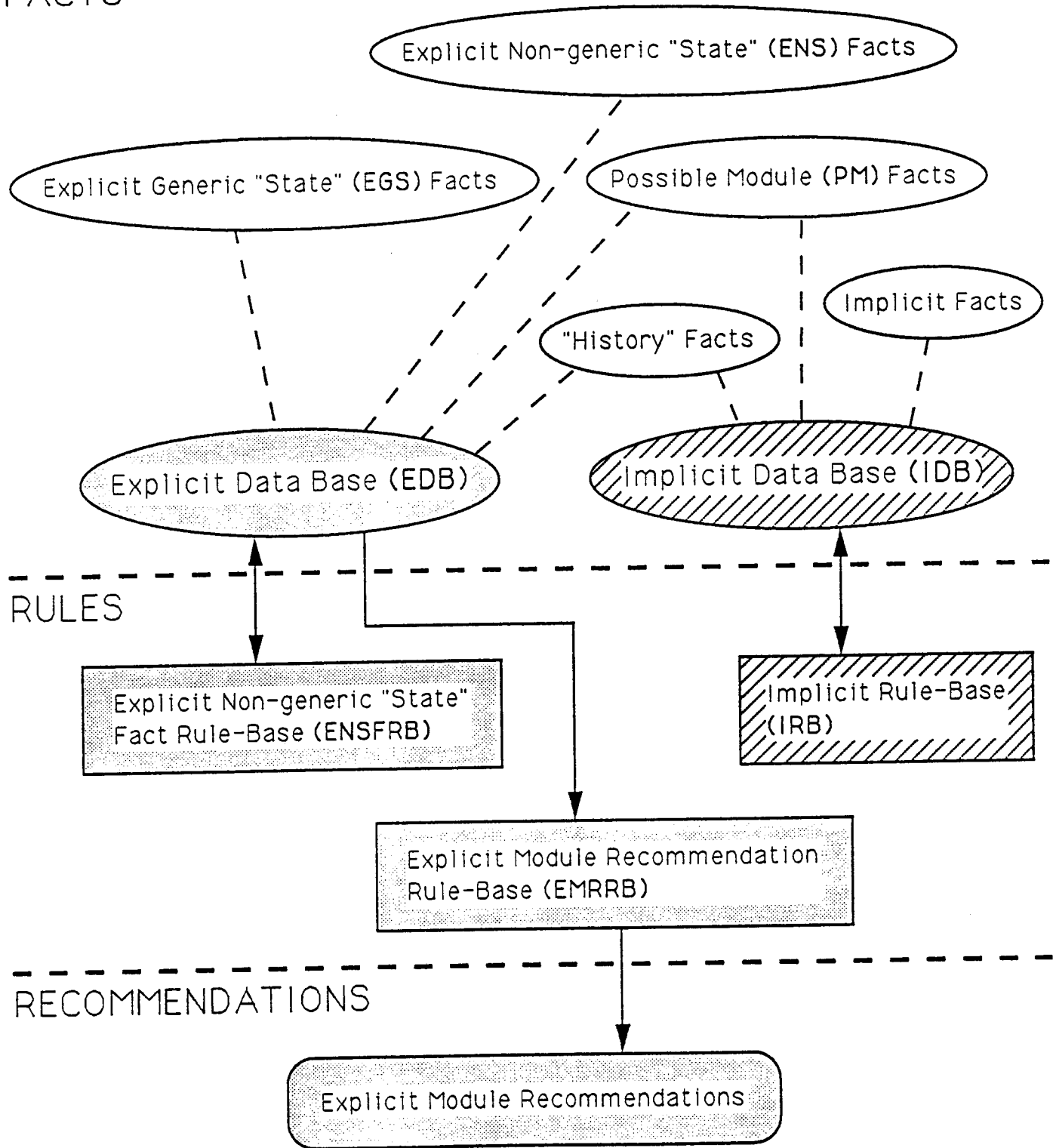
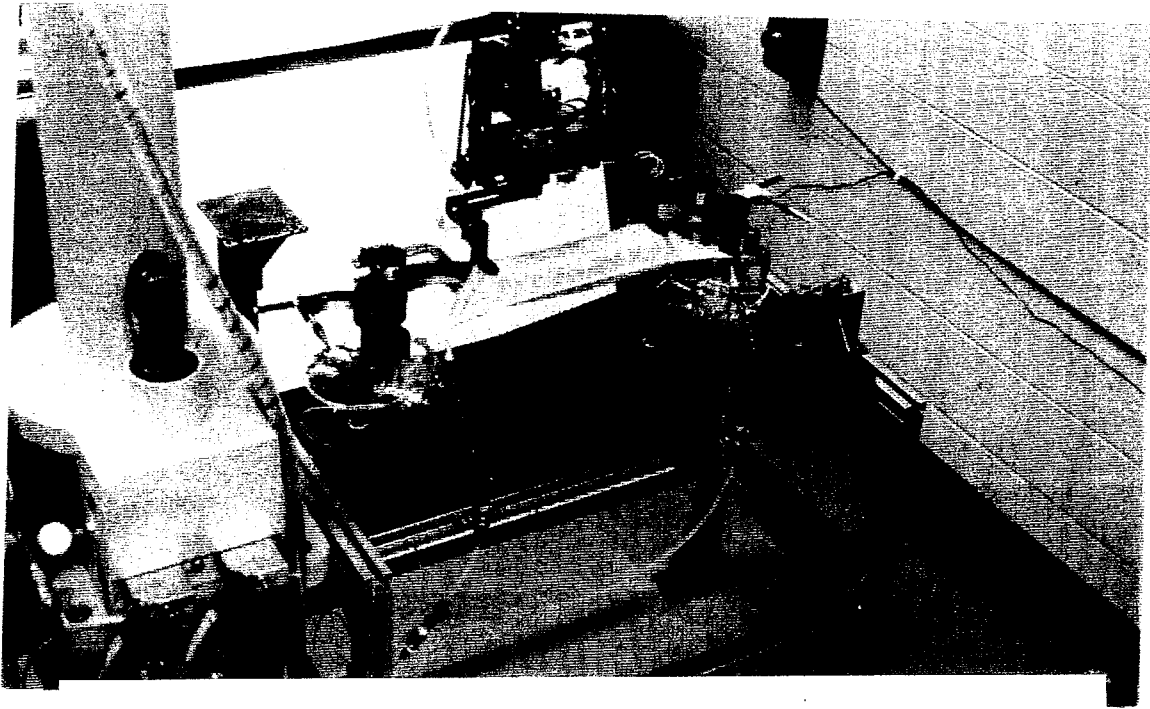
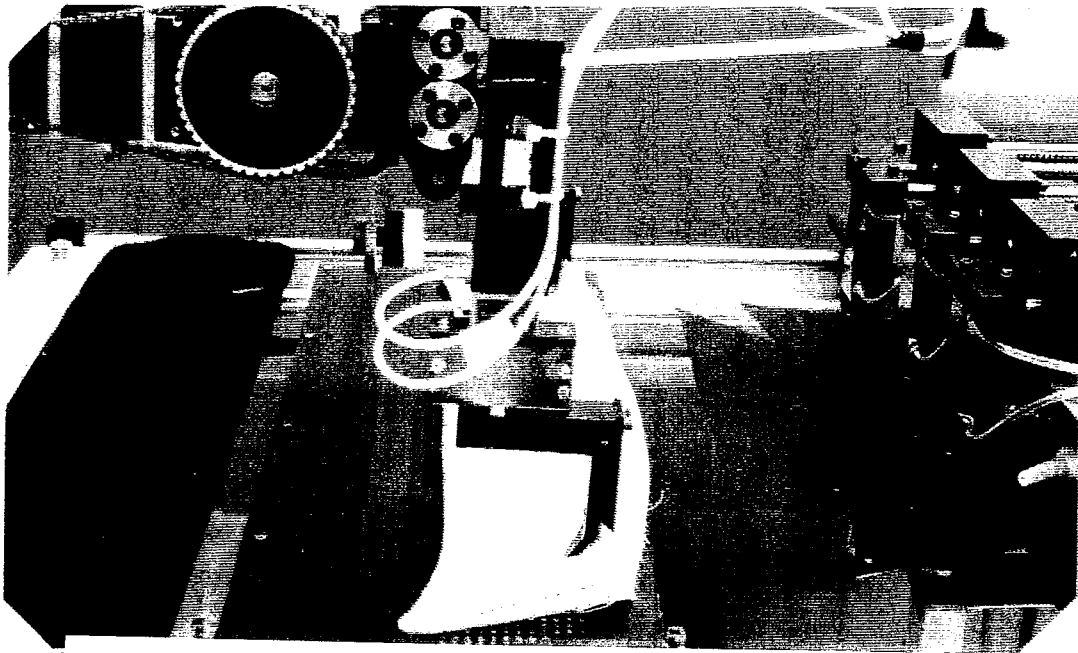

Figure 13. Organization of Databases and Rule-bases



(a) Turning device loaded with unturned collar



(b) Pressing device loaded with turned collar

Figure 14. Device Loading